

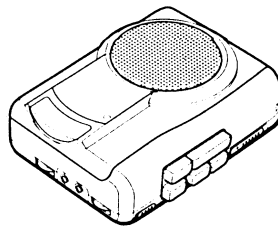

TP-VS530 YUBS YS



TP-VS530

SERVICE MANUAL

CASSETTE RECORDER

BASIC TAPE MECHANISM : TN-9XR-107

This Service Manual is the "Revision Publishing" and replaces "Simple Manual" (S/M Code No. 09-992-326-40A).

aiwa
S/M Code No. 09-993-325-8R1

REVISION
DATA

SPECIFICATIONS

Track system	2 tracks 1 channel, monaural
Frequency response	250 - 8,000 Hz EIAJ
Microphone	Electret condenser microphone (monaural)
Maximum output	300 mW (EIAJ/DC)
Input jack	EXT MIC jack (monaural mini-jack) (1)
Output jack	EARPHONE jack (monaural mini-jack) (1)
Other jack	DC 3 V jack
Speaker	Diameter 50 mm, 4 ohms
Recording system	DC bias
Erasing system	Magnet erasure
Power sources	DC 3 V using two R6 (size AA) dry cell batteries AC house current using the AC adaptor Aiwa AC-D302

Battery life

Battery	EIAJ Recording	EIAJ 10 mW
Manganese (R6P) Batteries	Approx. 5 hrs	Approx. 3.5 hrs
Alkaline (LR) batteries	Approx. 18.5 hrs	Approx. 13.5hrs

Dimensions 113.5 (W) x 90 (H) x 38.4 (D) mm
(4¹/₂ x 3⁵/₈ x 1⁹/₁₆ in.)

Weight Approx. 168 g, 5.9 oz (excluding batteries)

- Design and specifications are subject to change without notice.

ACCESSORIES LIST

DESCRIPTIONで判断できない物は "REFERENCE NAME LIST" を参照してください。
If can't understand for Description please kindly refer to "REFERENCE NAME LIST".

REF. NO	PART NO.	KANRI NO.	DESCRIPTION
1	8Z-HT9-903-010	IB, YU(3L)C<YUBS>	
1	8Z-HT9-907-010	IB, EZ(EGF)C<YS>	
2	8Z-HT9-908-010	IB, EZ(SID)C<YS>	
3	8Z-HT9-909-010	IB, EZ(PHNCZ)C<YS>	
4	87-PD3-050-010	STRAP, HAND	

ELECTRICAL MAIN PARTS LIST

DESCRIPTIONで判断できない物は "REFERENCE NAME LIST" を参照してください。
 If can't understand for Description please kindly refer to "REFERENCE NAME LIST".

REF. NO	PART NO.	KANRI NO.	DESCRIPTION	REF. NO	PART NO.	KANRI NO.	DESCRIPTION
IC				C118	87-016-462-080		C-CAP,S 1-16 F
	87-A20-399-010	IC,LA4168M		C119	87-010-187-080		CAP CHIP S5600P
TRANSISTOR				C151	87-A10-264-080		C-CAP,S 0.1-16ZF
	89-333-266-080	CHIP TR,2SC3326B		C152	87-016-462-080		C-CAP,S 1-16 F
	89-327-125-080	CHIP TR,2SC2712GR		C153	87-015-908-010		CAP, 220-4V
	87-A30-288-040	C-TR,DTC114YKA		C154	87-015-908-010		CAP, 220-4V
	89-341-165-080	CHIP TRANSISTOR 2SC4116GR		C155	87-015-676-010		CAP,E 47-6.3 7L
	89-342-132-080	TR,2SC4213		C181	87-015-695-010		CAP,E 1-50 7L
	87-A30-144-080	C-TR,2SC4081		C182	87-015-676-010		CAP,E 47-6.3 7L
DIODE				C183	87-016-462-080		C-CAP,S 1-16 F
	87-020-027-080	CHIP-DIODE 1SS184		C201	87-016-462-080		C-CAP,S 1-16 F
	87-020-339-080	CHIP DIODE,1SS226		C401	87-A10-264-080		C-CAP,S 0.1-16ZF
	88-HC6-612-080	C-DIODE,RB411D		C402	87-A10-264-080		C-CAP,S 0.1-16ZF
MAIN C.B				C403	87-016-491-080		C-CAP,S 0.22-16 FZ
C101	87-015-676-010	CAP,E 47-6.3 7L		D101	87-A40-529-010		DIODE,1GWJ42
C102	87-016-462-080	C-CAP,S 1-16 F		J101	84-TM1-630-010		JACK,3.5 HSJ1493-05
C103	87-016-462-080	C-CAP,S 1-16 F		J102	87-A60-849-010		JACK,DC DIA 2.75 BLK
C104	87-010-186-080	CAP,CHIP 4700P		J103	84-TM1-630-010		JACK,3.5 HSJ1493-05
C105	87-010-184-080	CHIP CAPACITOR 3300P(K)		SW101	87-A90-305-010		SW,SL 2-2-2 (NC)
C106	87-015-695-010	CAP,E 1-50 7L		SW102	87-031-816-010		SLIDE SWITCH
C107	87-015-681-010	ELECTROLYTIC SRA 10U 16V		SW181	87-031-816-010		SLIDE SWITCH
C108	87-015-677-010	ELECTROLYTIC 100U 6.3V		TH201	87-A90-855-080		C-THMS,SC20-3K102K
C109	87-015-674-010	CAP 22U-6.3V		TH202	87-A90-307-080		C-THMS,K39G220
C110	87-010-186-080	CAP,CHIP 4700P		VR101	87-A90-314-010		VR,RTRY 10K H
C111	87-015-698-010	ELECTROLYTIC SRA 50V-4.7U		VR201	87-A90-308-010		VR,RTRY 3KB XV81
C113	87-016-462-080	C-CAP,S 1-16 F		VR202	87-A90-527-010		SFR,5K H VZ066L3
C114	87-016-462-080	C-CAP,S 1-16 F		LED C.B			
C115	87-015-675-010	ELECTROLYTIC 33U 6.3V		LED304	87-017-827-070		C-LED,SEC 1201C RED
C116	87-010-197-080	CAP, CHIP 0.01 DM					

○チップ抵抗部品コード／CHIP RESISTOR PART CODE

チップ抵抗部品コードの成り立ち

Chip Resistor Part Coding

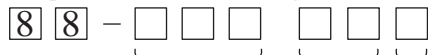

A
抵抗部品コード
Resistor Code

桁表示
Figure
抵抗値
Value of resistor

チップ抵抗 Chip resistor

容量 Wattage	種類 Type	許容誤差 Tolerance	記号 Symbol	寸法/Dimensions (mm)			抵抗コード : A Resistor Code : A	
				外形/Form	L	W		t
1/16W	1005	± 5%	CJ		1.0	0.5	0.35	104
1/16W	1608	± 5%	CJ		1.6	0.8	0.45	108
1/10W	2125	± 5%	CJ		2	1.25	0.45	118
1/8W	3216	± 5%	CJ		3.2	1.6	0.55	128

SCHEMATIC DIAGRAM

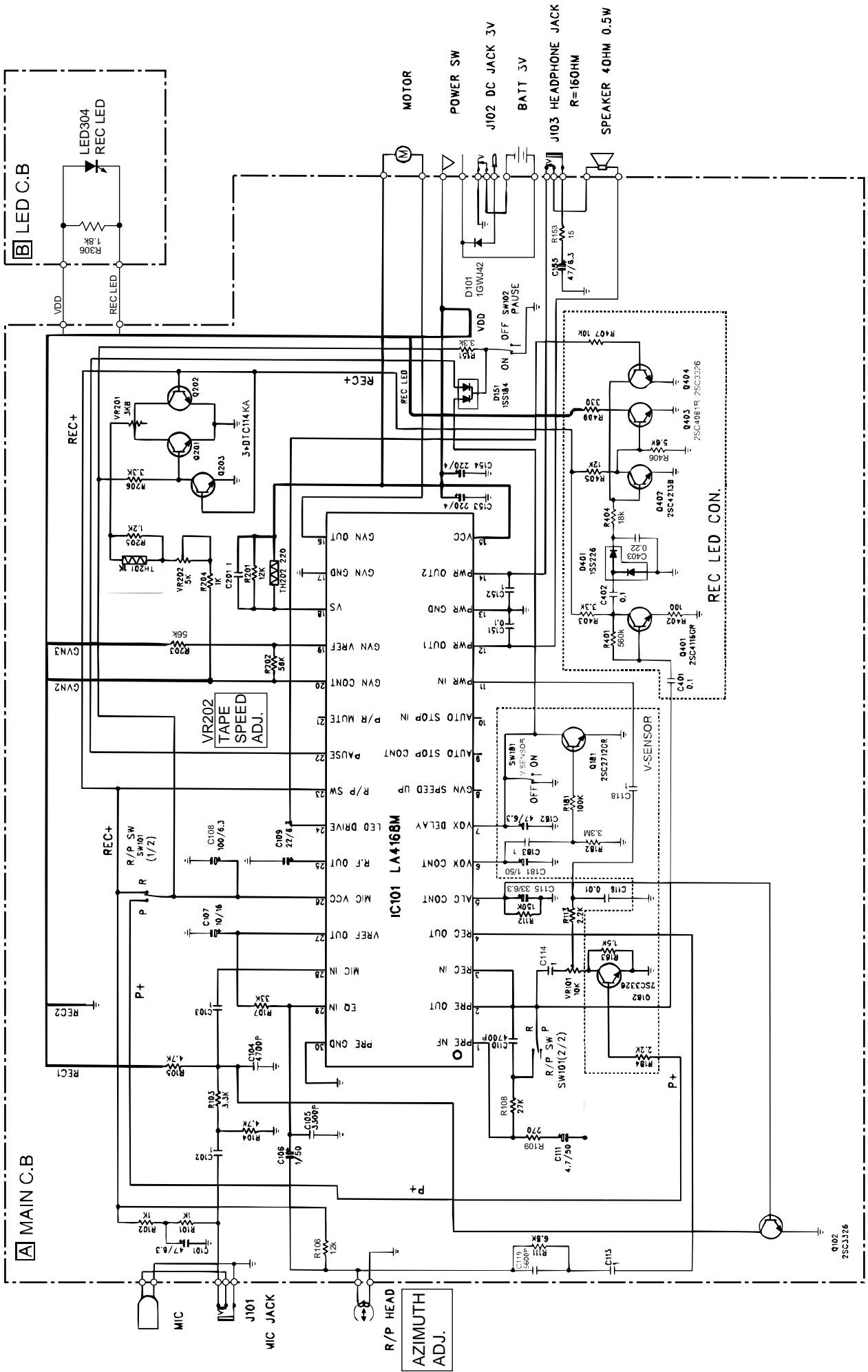

WIRING-1 (MAIN C.B)

1 2 3 4 5 6 7 8 9 10 11 12 13 14

A
B
C
D
E
F
G
H
I
J

MAIN C.B [BOTTOM VIEW]

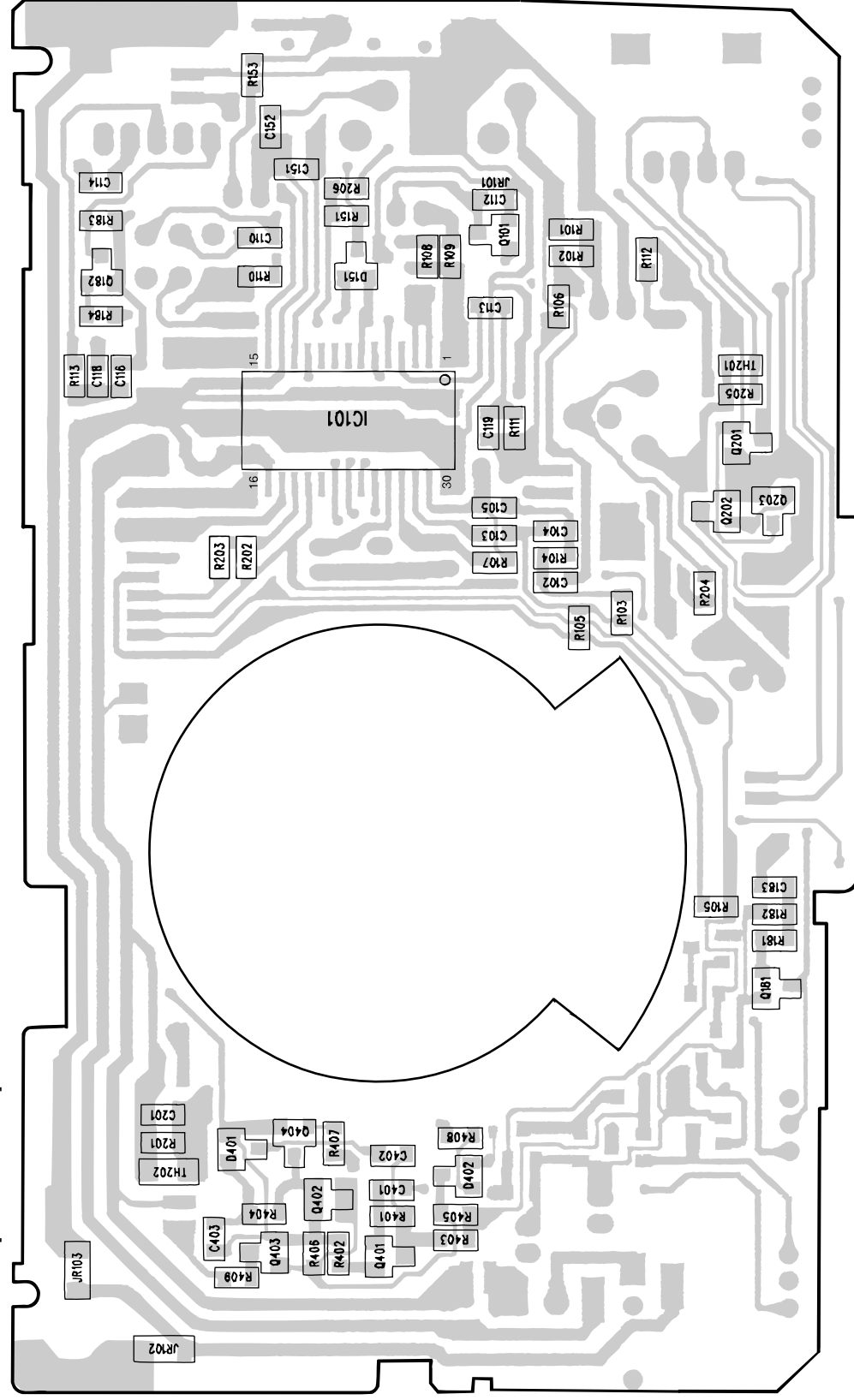

MAIN C.B [TOP VIEW]

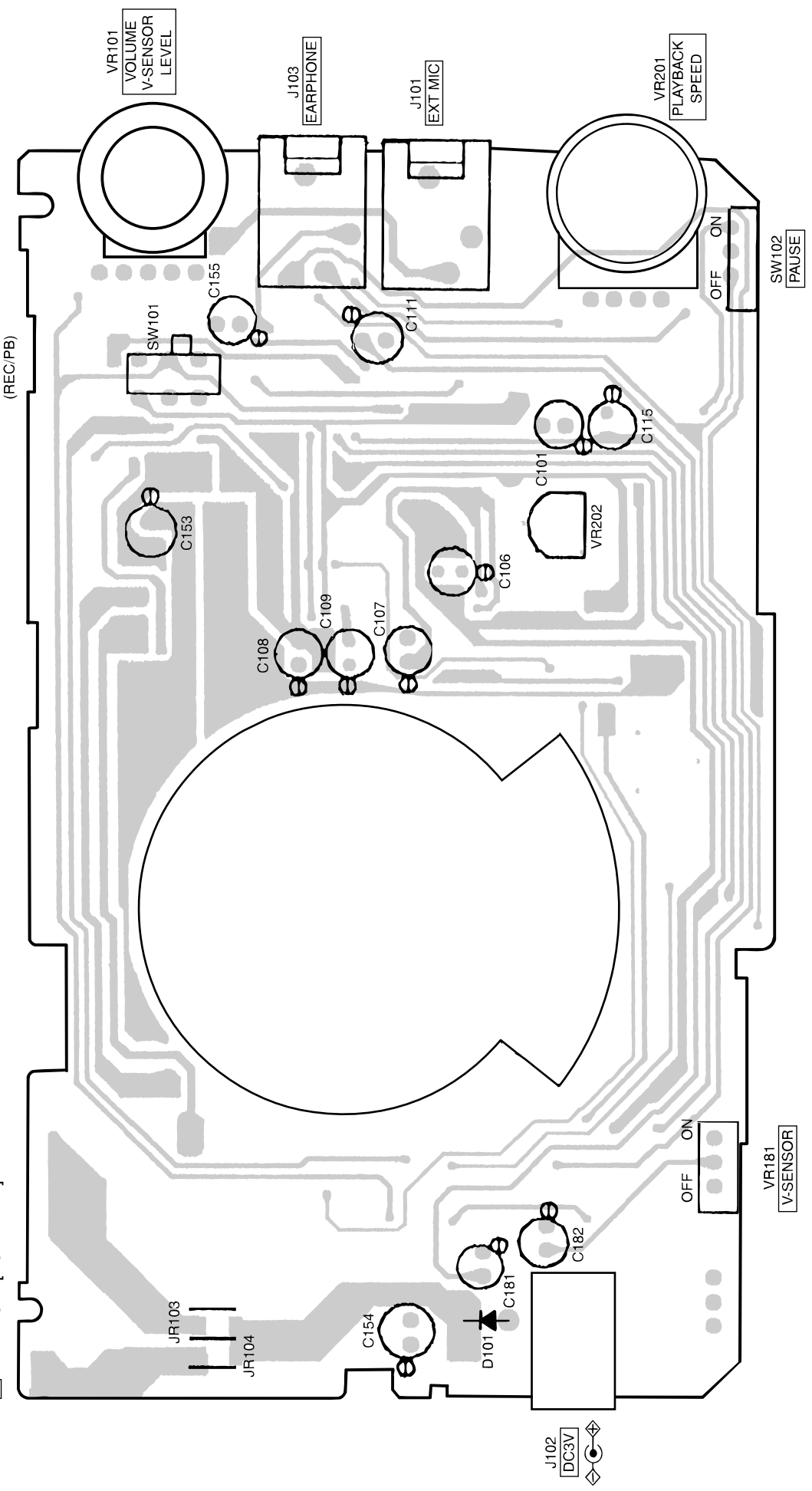

WIRING-2 (LED C.B)

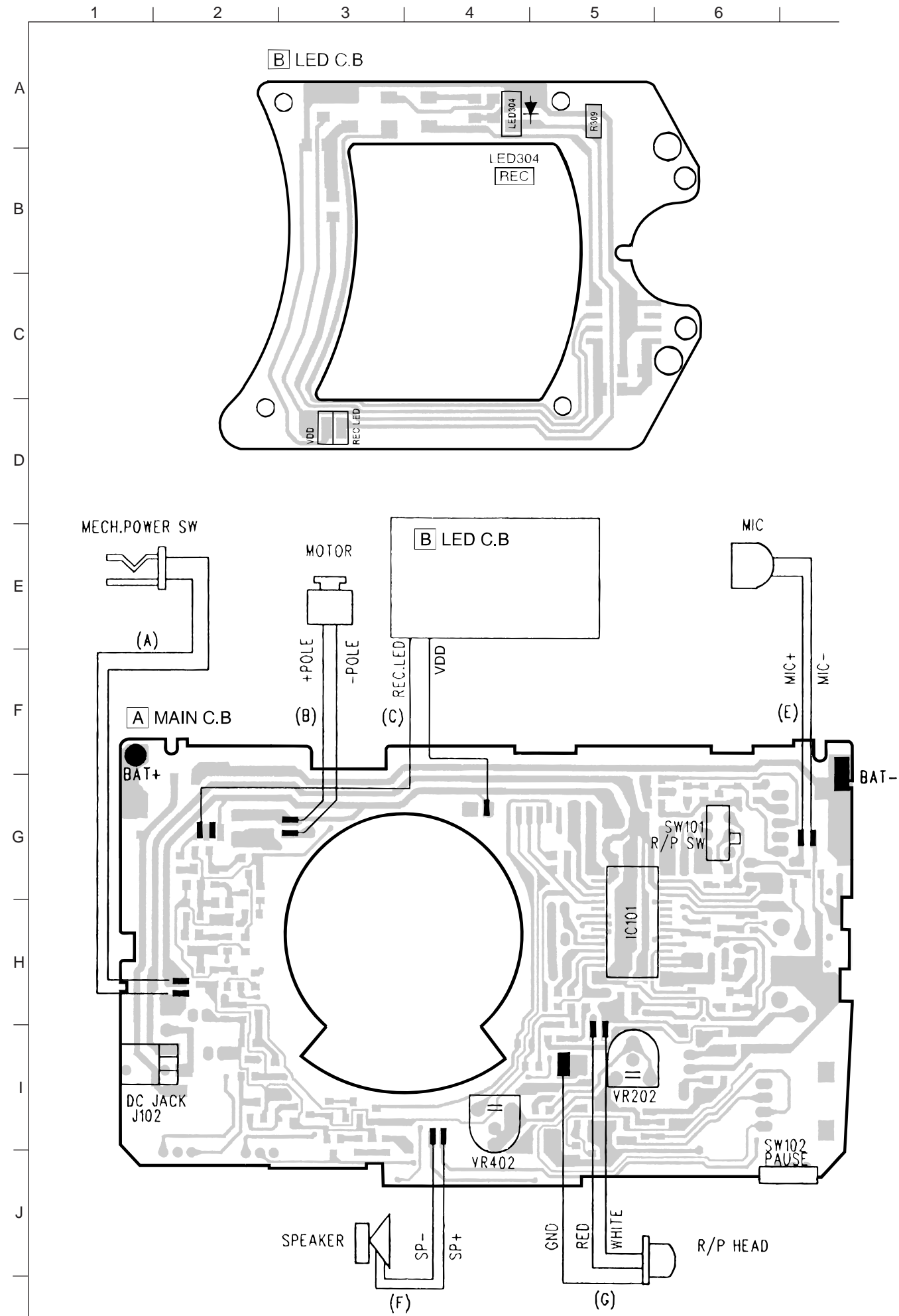

ELECTRICAL ADJUSTMENT

A MAIN C.B

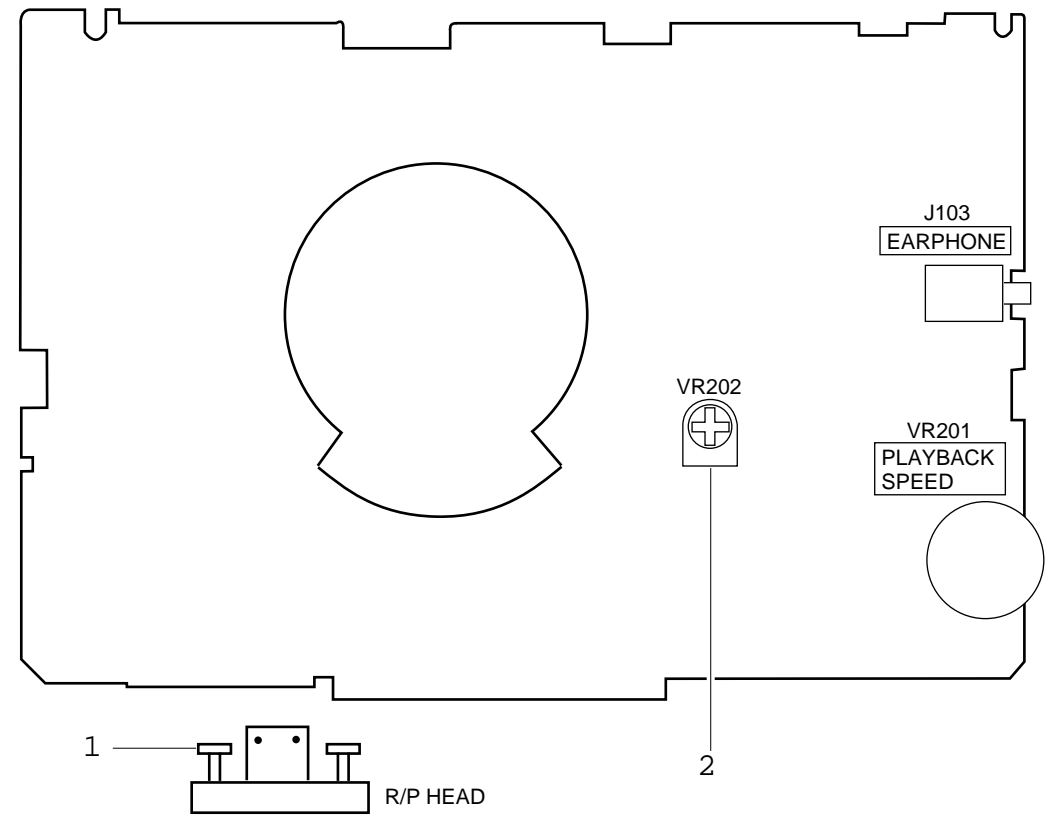

1. Azimuth Adjustment

- Settings:
- Test tape: TTA-330
 - Test point: EARPHONE JACK (J103)
 - Adjustment location: Azimuth adjustment screw
 - PAUSE: OFF
 - VOLUME: Maximum.
- Method: Play back the test tape, and adjust so that the output (8 kHz) becomes maximum.

2. Tape Speed Adjustment (4.8 cm/s)

- Settings:
- Test tape: TTA-100 (TAPE CENTER)
 - Test point: EARPHONE JACK (J103)
 - Adjustment location: VR202
 - PAUSE: OFF
 - VOLUME: Maximum
 - PLAYBACK SPEED: Normal
(Speed volume center)
- Method: Play back the test tape, and adjust for 3000 Hz ± 10 Hz

PRACTICAL SERVICE FIGURE

Tape speed:	3000 Hz \pm 60 Hz
Wow & flutter:	Less than 0.55% (4.8 cm/s) Less than 0.8% (2.4 cm/s)
Take-up torque:	20 ~ 50 g-cm (FWD)
F.F torque:	More than 55 g-cm
REW torque:	More than 55 g-cm
S/N ratio:	More than 56 dB (DC, PB) More than 26 dB (DC, R/PB)
Distortion:	Less than 3.0% (DC, PB) Less than 7.0% (DC, R/PB)
Noise level:	Less than 2.0 mV (PB, Vol Max., DC) Less than 16 mV (R/PB, Vol Max., DC) Less than 0.3 mV (PB, Vol Min, DC)
Erasing ratio:	More than 44 dB (1kHz)
Test tape	TTA-100 TTA-330

IC BLOCK DIAGRAM

IC, MM1206XF

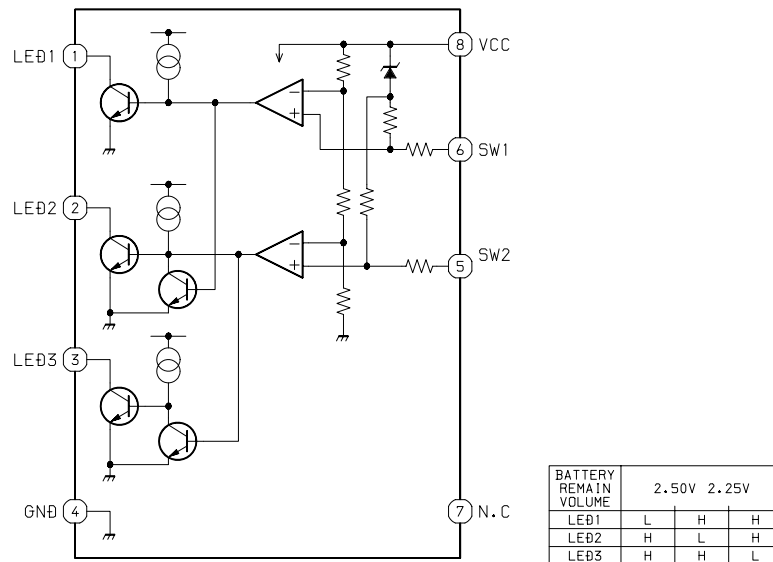

TRANSISTOR ILLUSTRATION

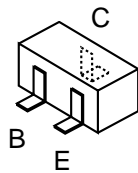

2SC2712
2SC3326
2SC4081
2SC4116
2SC4213
DTC114

MECHANICAL EXPLODED VIEW

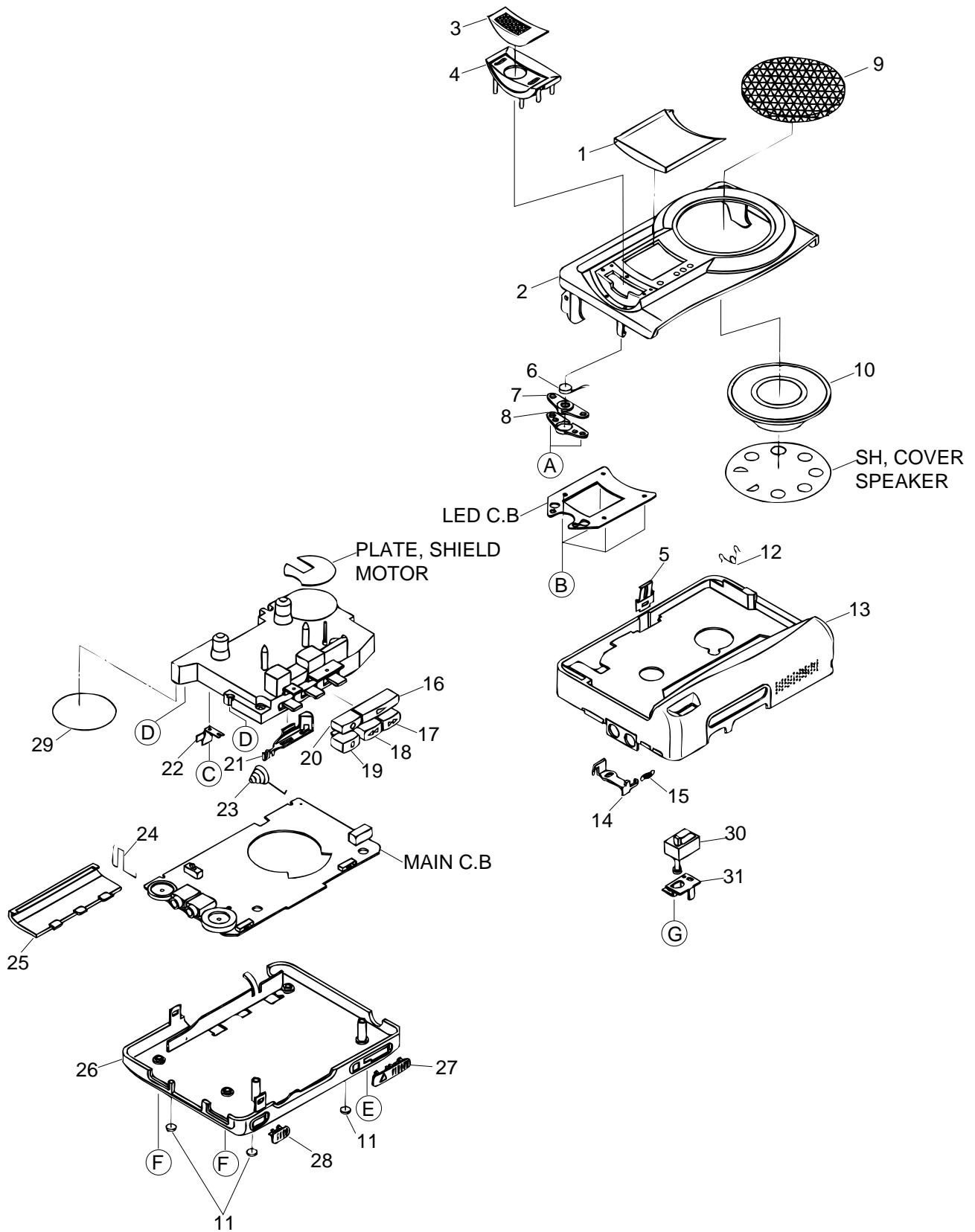

MECHANICAL MAIN PARTS LIST

DESCRIPTIONで判断できない物は "REFERENCE NAME LIST" を参照してください。
 If can't understand for Description please kindly refer to "REFERENCE NAME LIST".

REF. NO	PART NO.	KANRI NO.	DESCRIPTION	REF. NO	PART NO.	KANRI NO.	DESCRIPTION
1	8Z-HT9-007-010		WINDOW,CASS	21	8Z-HT7-203-010		LEVER, PAUSE
2	8Z-HT9-001-010		LID,CASS	22	87-HT8-204-010		LEVER,REC ACTUATOR
3	8Z-HT7-004-010		GRILLE,MIC	23	8Z-HT7-206-010		BAT-CONTACT, (-)
4	8Z-HT7-005-010		PANEL,MIC	24	8Z-HT7-205-010		BAT-CONTACT, (+)
5	87-HT8-203-010		SPR-P,CASS	25	8Z-HT7-007-010		LID,BATT
6	82-TP3-609-010		ECM	26	8Z-HT9-003-010		CABI,REAR
7	8Z-HT7-201-010		HLDR,MIC	27	8Z-HT7-009-010		KNOB,SL SLSS
8	8Z-HT7-204-010		COVER, MIC	28	8Z-HT7-008-010		KNOB,SL PAUSE
9	8Z-HT7-010-010		GRILLE,SPEAKER	29	87-HT8-210-010		BELT,COUNTER
10	87-A91-158-010		SPKR,DIA 50 4OHM 1.0W	30	87-040-196-010		COUNTER
11	8Z-HT7-012-010		FOOT,RUBBER	31	87-HT8-202-010		HLDR,COUNTER
12	87-HT8-208-010		SPR-T,LID CASS	A	87-B10-234-010		QT2+1.4-3 BLK
13	8Z-HT9-002-010		FRAME,CENTER	B	87-268-527-310		V HEAD SCREW D1.7-3<YUBS>
14	87-HT8-205-010		LEVER,REC SAFETY	C	87-264-521-310		V+1.7-1.6 CR
15	87-HT8-209-010		SPR-E,REC SAFETY	D	87-067-271-010		SCREW VFT2+1.7-4
16	8Z-HT6-010-010		BTN,PLAY	E	87-HT8-211-010		VT2+2-18 S-SCREW BLK
17	8Z-HT6-012-010		BTN,FF	F	87-067-769-010		VT2+1.7-8(3) BLK
18	8Z-HT6-013-010		BTN,REW	G	87-354-529-310		VT2+1.7-4
19	8Z-HT6-014-010		BTN,STOP				
20	8Z-HT6-011-010		BTN,REC				

TAPE MECHANISM EXPLODED VIEW 1/1

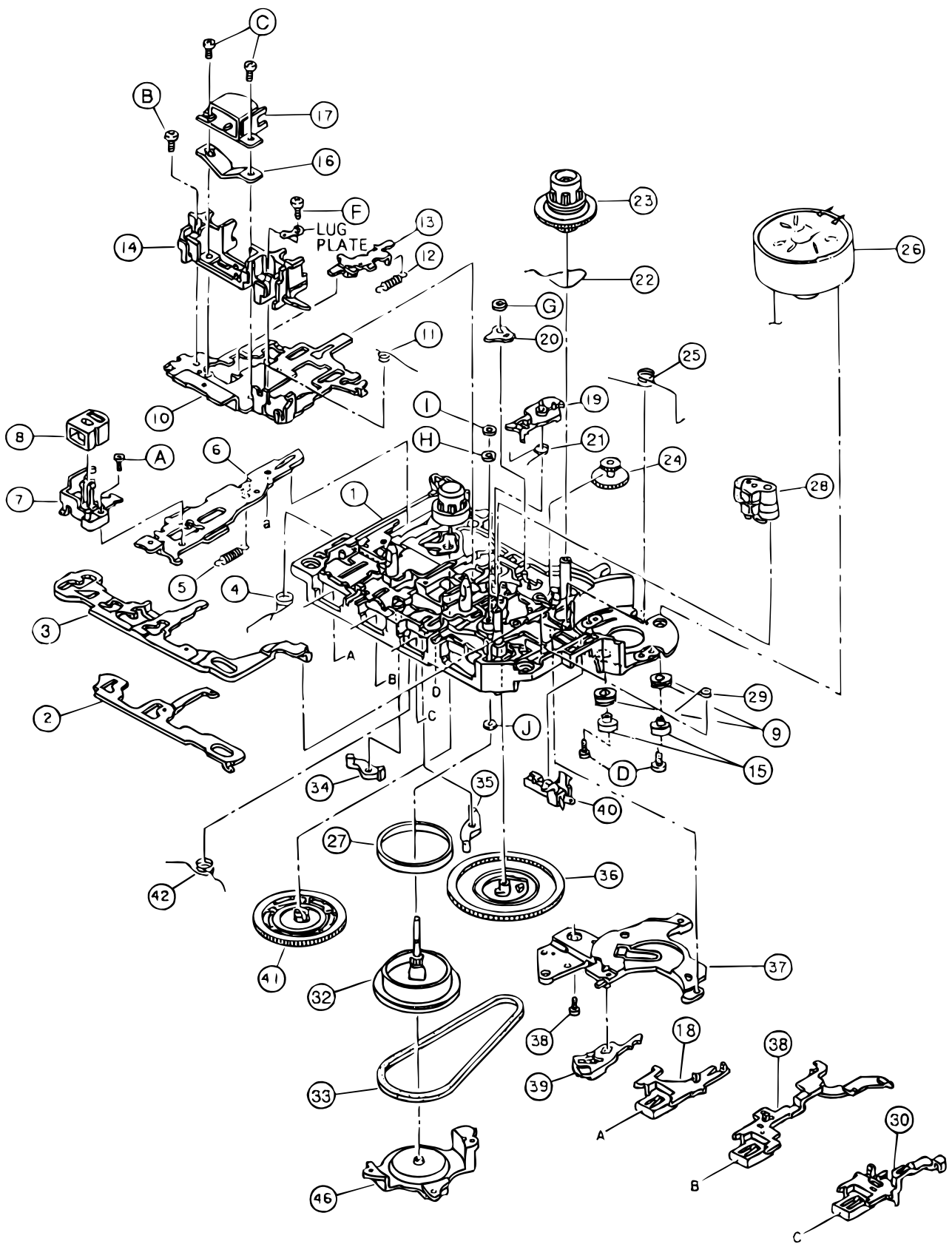

TAPE MECHANISM PARTS LIST 1/1

DESCRIPTIONで判断できない物は "REFERENCE NAME LIST" を参照してください。
 If can't understand for Description please kindly refer to "REFERENCE NAME LIST".

REF. NO	PART NO.	KANRI NO.	DESCRIPTION	REF. NO	PART NO.	KANRI NO.	DESCRIPTION
1	S1-909-013-050		CHASSIS ASSY	31	S1-909-053-040		FLYWHEEL ASSY
2	S1-909-020-190		FR PLATE	32	S1-909-080-100		MAIN BELT
3	S1-909-020-090		LOCK PLATE	33	S1-909-050-100		FL BRACKET
4	S1-909-020-140		STOP SPRING	34	S1-909-020-150		R/C LEVER(R)
5	S1-909-120-080		REC LEVER SPRING	35	S1-909-020-160		R/C LEVER(F)
6	S1-909-120-070		REC LEVER	36	S1-909-060-120		CAM GEAR
7	S1-909-120-020		MG GUIDE	37	S1-909-020-170		R/C BRACKET
8	S6-207-100-020		HEAD E TC-230AN(SL)	38	S1-909-020-110		RWD LEVER
9	S1-852-140-020		M LUBBER	39	S1-909-020-180		FF STOPPER
10	S1-909-030-050		HEAD PANEL	40	S6-401-011-630		LEAF SW MSW-1541TA
11	S1-909-040-060		P/R SPRING	41	S1-909-070-020		RWD GEAR
12	S1-909-030-080		R/C SPRING	42	S1-909-020-130		FR SPRING
13	S1-909-030-070		R/C PLATE	A	S9-C01-174-030		CAMERA 1.7-4
14	S1-909-030-060		TAPE GUIDE	B	S9-C01-173-530		CAMERA 1.7-3.5
15	S1-852-140-030		M COLLER	C	S9-P14-203-310		+/- SCREW M2-3.3
16	S1-944-030-020		HEAD SPRING PLATE	D	S9-C18-300-100		CAMERA 1.7-3
17	S6-205-020-130		PR HEAD RM-7521-A	E	S9-P08-173-410		PST 1.7-3.4
18	S1-909-020-100		STOP LEVER	F	S9-P14-206-320		+/- SCREW M2-3.6
19	S1-909-110-040		AUTO LEVER	G	S9-W02-300-100		P WASHER CUT 1.2-3.8-0.3
20	S1-909-110-020		A PUSH ARM	H	S9-W08-350-200		LUMILER WASHER CUT 0.98-3-0.3
21	S1-909-110-050		M CONTROL SPRING	I	S9-W05-200-600		HL WASHER 1.16-3-0.2
22	S1-909-060-150		SENSOR SPRING C	J	S9-W05-200-100		HL WASHER 1.55-3-0.13
23	S1-909-063-030		T REEL ASSY				
24	S1-909-060-130		TAKE UP GEAR				
25	S1-909-030-090		HP SPRING				
26	S1-909-083-060		MOTOR ASSY				
27	S1-909-050-130		BRAKE BELT				
28	S1-909-043-010		PINCH ROLLER ASSY				
29	S1-909-020-200		FR PLATE SPRING				
30	S1-909-020-120		FF LEVER				

REFERENCE NAME LIST

ELECTRICAL SECTION

DESCRIPTION	REFERENCE NAME
ANT	ANTENNAS
C-	CHIP
C-CAP	CAP, CHIP
C-CAP TN	CAP, CHIP TANTALUM
C-COIL	COIL, CHIP
C-DI	DIODE, CHIP
C-DIODE	DIODE, CHIP
C-FET	FET, CHIP
C-FOTR	FILTER, CHIP
C-JACK	JACK, CHIP
C-LED	LED, CHIP
C-RES	RES, CHIP
C-SFR	SFR, CHIP
C-SLIDE SW	SLIDE SWITCH, CHIP
C-SW	SWITCH, CHIP
C-TR	TRANSISTOR, CHIP
C-VR	VOLUME, CHIP
C-ZENER	ZENER, CHIP
CAP, CER	CAP, CERA-SOL
CAP, E	CAP, ELECT
CAP, M/F	CAP, FILM
CAP, TC	CAP, CERA-SOL
CAP, TC-U	CAP, CERA-SOL SS
CAP, TN	CAP, TANTALUM
CERA FIL	FILTER, CERAMIC
CF	FILTER, CERAMIC
DL	DELAY LINE
E/CAP	CAP, ELECT
FILT	FILTER
FLTR	FILTER
FUSE RES	RES, FUSE
MOT	MOTOR
P-DIODE	PHOTO DIODE
P-SNSR	PHOTO SENSER
P-TR	PHOTO TRANSISTOR
POLY VARI	VARIABLE CAPACITOR
PPCAP	CAP, PP
PT	POWER TRANSFORMER
PTR, RES	PTR, MELF
RC	REMOTE CONTROLLER
RES NF	RES, NON-FLAMMABLE
RESO	RESONATOR
SHLD	SHIELD
SOL	SOLENOID
SPKR	SPEAKER
SW, LVR	SWITCH, LEVER
SW, RTRY	SWITCH, ROTARY
SW, SL	SWITCH, SLIDE
TC CAP	CAP, CERA-SOL
THMS	THERMISTOR
TR	TRANSISTOR
TRIMMER	CAP, TRIMMER
TUN-CAP	VARIABLE CAPACITOR
VIB, CER	RESONATOR, CERAMIC
VIB, XTAL	RESONATOR, CRYSTAL
VR	VOLUME
ZENER	DIODE, ZENER

MECHANICAL SECTION

DESCRIPTION	REFERENCE NAME
ADHESHIVE	SHEET ADHESHIVE
AZ	AZIMUTH
BAR-ANT	BAR-ANTENNA
BAT	BATTERY
BATT	BATTERY
BRG	BEARING
BTN	BUTTON
CAB	CABINET
CASS	CASSETTE
CHAS	CHASSIS
CLR	COLLAR
CONT	CONTROL
CRSR	CURSOR
CU	CUSHION
CUSH	CUSHION
DIR	DIRECTION
DUBB	DUBBING
FL	FRONT LOADING
FLY-WHL	FLYWHEEL
FR	FRONT
FUN	FUNCTION
G-CU	G-CUSHION
HDL	HANDOL
HIMERON	CLOTH
HINGE, BAT	HINGE, BATTERY
HLDR	HOLDER
HT-SINK	HEAT SINK
IB	INSTRUCTION BOOKLET
IDLE	IDLER
IND, L-R	INDICATOR, L-R
KEY, CONT	KEY, CONTROL
KEY, PRGM	KEY, PROGRAM
KNOB, SL	KNOB, SLIDE
LBL	LABEL
LID, BATT	LID, BATTERY
LID, CASS	LID, CASSETTE
LVR	LEVER
P-SP	P-SPRING
PANEL, CONT	PANEL, CONTROL
PANEL, FR	PANEL, FRONT
PRGM	PROGRAM
PULLY, LOAD MO	PULLY, LOAD MOTOR
RBN	RIBBON
S-	SPECIAL
SEG	SEGMENT
SH	SHEET
SHLD-SH	SHIELD-SHEET
SL	SLIDE
SP	SPRING
SP-SCREW	SPECIAL-SCREW
SPACER, BAT	SPACER, BATTERY
SPR	SPRING
SPR-P	P-SPRING
SPR-PC-PUSH	P-SPRING, C-PUSH
T-SP	T-SPRING
TERM	TERMINAL
TRIG	TRIGGER
TUN	TUNING
VOL	VOLUME
W	WASHER
WHL	WHEEL
WORM-WHL	WORM-WHEEL

サービス技術ニュース	
番号	連絡内容
G- -	
G- -	
G- -	

アイワ株式会社 〒110-8710 東京都台東区池之端1-2-11 ☎03(3827)3111 (代表)

AIWA CO., LTD. 2-11, IKENOHATA 1-CHOME, TAITO-KU, TOKYO 110-8710, JAPAN TEL:03 (3827) 3111