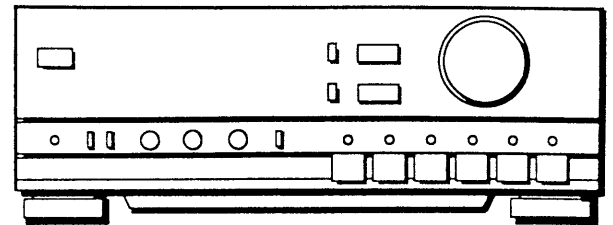

XA-005**AIWA®**

R.R.

**SERVICE
MANUAL**

STEREO INTEGRATED AMPLIFIER

•TYPE. H,E,K,Z

SPECIFICATIONS

Common

Power requirements	XA-005E, Z 220 V, 50 Hz XA-005K 240 V, 50 Hz XA-005H 120 V/220 V/240 V (switchable), 50/60 Hz
Power consumption	XA-005E, K, Z 350 W XA-005H 125 W
Power amplifier	
Effective output power	70 W+70 W (4 ohms, T.H.D. 0.9%, 1 kHz) 50 W+50 W (8 ohms, T.H.D. 0.9%, 1 kHz)
Total harmonic distortion	0.05% (20 Hz-20 kHz, 40 W, 8 ohms) 20 Hz-20 kHz (less than 0.05%) [Both channels driven, 8 ohms]
Output bandwidth	20 Hz-20 kHz (less than 0.05%) [Both channels driven, 8 ohms]
Frequency response	5 Hz-100 kHz (+0.5/-3 dB)

Preamplifier

S/N ratio	IHF A curve short circuited PHONO (MM) 85 dB (5 mV INPUT) TUNER, DAT, VCR (AUX), TAPE 100 dB
------------------	--

Input jacks**(Sensitivity/Input Impedance)**

PHONO (MM)	2.5 mV/47 kohms
TUNER, DAT, VCR (AUX), TAPE	150 mV/47 kohms
CD	150 mV/47 kohms
PHONO overload level	85 mV (MM) [1 kHz, THD 0.01%]

Output jacks**(Level/output Impedance)**

TAPE	150 mV/47 kohms
Headphones	8-32 ohms
Speakers	4-16 ohms (A+B: 8-16 ohms)
RIAA deviation	±0.5 dB (30 Hz-15 kHz)

Dimensions

430(W) × 140(H) × 320(D) mm

Weight

7 kg

• Design and specifications are subject to change without notice.

AIWA Co., Ltd.

Tokyo Japan

Printed in Japan

ELECTRICAL MAIN PARTS LIST

REF. NO.	PART NO.	DESCRIPTION	REF. NO.	PART NO.	DESCRIPTION
===IC===			C86	*87-010-756-019	CAP, ELECT 6800-50
	87-001-171-019	IC, NJM2068D	C91	*87-018-134-019	CAP, CERA-SOL SS 0.01
	87-027-897-019	IC, UPC1225H	C231	*87-014-210-010	CAP, MYLAR 0.047-250V(Z)
	87-027-787-019	IC, UPC1237H	C232	*87-014-210-010	CAP, MYLAR 0.047-250V(Z)
===TRANSISTOR===			ΔFU1	87-035-254-010	FUSE 2.5A(H)
	89-110-155-019	TRANSISTOR, 2SA1015(GR)	ΔFU1	87-035-370-010	FUSE T6.3A 250V(E, K, Z)
	89-112-642-010	TRANSISTOR, 2SA1264(R, O)	ΔFU2	87-035-254-010	FUSE 2.5A(H)
	89-210-155-019	TRANSISTOR, 2SB1015	ΔFU2	87-035-370-010	FUSE T6.3A 250V(E, K, Z)
	89-322-405-019	TRANSISTOR, 2SC2240(GR)	J2	87-009-023-019	JACK PIN YKC21-0349(PHONO)(TUNER)
	89-331-812-010	TRANSISTOR, 2SC3181(R, O)	J3	87-049-868-019	JACK PIN 4P(CD)(VCR/AUX)
	89-334-194-019	TRANSISTOR, 2SC3419Y	J4	87-049-868-019	JACK PIN 4P(TAPE2/DAT)
	89-414-065-019	TRANSISTOR, 2SD1406 GR	J5	87-049-868-019	JACK PIN 4P(TAPE1)
===DIODE===			L1	*87-005-158-010	COIL 1UH
	87-020-110-019	DIODE 1SS177	L2	*87-005-158-010	COIL 1UH
	87-020-123-019	DIODE DS446	LED1	87-001-779-019	LED SLH56VC RED-F(PHONO IND.)
	87-001-135-010	DIODE KBU8DL	LED2	87-001-779-019	LED SLH56VC RED-F(TUNER IND.)
	87-020-945-010	DIODE MPG06D	LED3	87-001-779-019	LED SLH56VC RED-F(CD IND.)
	87-027-449-019	DIODE, ZENER HZ15-3L	LED4	87-001-779-019	LED SLH56VC RED-F(VCR/AUX IND.)
			LED5	87-001-779-019	LED SLH56VC RED-F(TAPE2/DAT IND.)
			LED6	87-001-779-019	LED SLH56VC RED-F(TAPE1/MONITOR IND.)
===MAIN CIRCUIT BOARD SECTION===			R73	*87-025-120-010	RES, MFO 10-1W
Δ C1	*87-033-147-019	FUSE CLAMP	R74	*87-025-120-010	RES, MFO 10-1W
C2	*87-018-121-019	CAP, CERA-SOL SS 150P(Z)	R75	*87-025-434-010	RES, CEMENT 0.22-5W
C3	*87-018-121-019	CAP, CERA-SOL SS 150P(Z)	R76	*87-025-434-010	RES, CEMENT 0.22-5W
C4	*87-018-121-019	CAP, CERA-SOL SS 150P(Z)	R77	*87-025-434-010	RES, CEMENT 0.22-5W
C5	*87-018-121-019	CAP, CERA-SOL SS 150P(Z)	R78	*87-025-434-010	RES, CEMENT 0.22-5W
C6	*87-018-121-019	CAP, CERA-SOL SS 150P(Z)	R91	*87-025-194-010	RES, MFO 220-2W
C7	*87-018-121-019	CAP, CERA-SOL SS 150P(Z)	R92	*87-025-194-010	RES, MFO 220-2W
C8	*87-018-121-019	CAP, CERA-SOL SS 150P(Z)	ΔR100	87-029-017-019	RES, FUSE 10-1/4W
C9	*87-018-121-019	CAP, CERA-SOL SS 150P(Z)	ΔR101	87-029-017-019	RES, FUSE 10-1/4W
C10	*87-018-121-019	CAP, CERA-SOL SS 150P(Z)	ΔR102	87-029-124-019	RWS, FUSE 2.2-1/4W
C11	*87-018-121-019	CAP, CERA-SOL SS 150P(Z)	RY1	87-045-281-010	RELAY, G5R24VSP
C12	*87-018-121-019	CAP, CERA-SOL SS 150P(Z)	SFR1	*87-024-165-019	SFR 220
C13	*87-018-121-019	CAP, CERA-SOL SS 150P(Z)	SFR2	*87-024-165-019	SFR 220
C14	*87-018-121-019	CAP, CERA-SOL SS 150P(Z)	SW1	89-AA2-620-019	PUSH SW(PHONO)
C21	*87-010-404-019	CAP, ELECT 4.7-50V SME	SW2	+	PUSH SW(TUNER)
C22	*87-010-404-019	CAP, ELECT 4.7-50V SME	SW3	+	PUSH SW(CD)
C23	*87-018-121-019	CAP, CERA-SOL SS 150P	SW4	+	PUSH SW(VCR/AUX)
C24	*87-018-121-019	CAP, CERA-SOL SS 150P	SW5	+	PUSH SW(TAPE2/DAT)
C25	*87-010-370-019	CAP, ELECT 330-6.3V	SW6	+	PUSH SW(TAPE1/MONITOR)
C26	*87-010-370-019	CAP, ELECT 330-6.3V	TH1	82-304-722-010	THERMISTOR 42D26
C33	*87-010-404-019	CAP, ELECT 4.7-50V SME	TH2	82-304-722-010	THERMISTOR 42D26
C34	*87-010-404-019	CAP, ELECT 4.7-50V SME	===FRONT CIRCUIT BOARD SECTION===		
C35	*87-010-260-019	CAP, ELECT 47-25V	C151	*87-018-126-019	CAP, CERA-SOL SS 390P
C36	*87-010-260-019	CAP, ELECT 47-25V	C152	*87-018-126-019	CAP, CERA-SOL SS 390P
C37	*87-012-110-019	CAP, CERA-SOL 270P BEAD(Z)	C155	*87-010-401-019	CAP, ELECT 1-50V
C38	*87-012-110-019	CAP, CERA-SOL 270P BEAD(Z)	C156	*87-010-401-019	CAP, ELECT 1-50V
C45	*87-010-405-019	CAP, ELECT 10-50V SME	C157	*87-018-121-019	CAP, CERA-SOL SS 150P
C46	*87-010-405-019	CAP, ELECT 10-50V SME	C158	*87-018-121-019	CAP, CERA-SOL SS 150P
C49	*87-018-131-019	CAP, CERA-SOL SS 1000P	C159	*87-010-403-019	CAP, ELECT 3.3-50V SME
C50	*87-018-131-019	CAP, CERA-SOL SS 1000P	C160	*87-010-403-019	CAP, ELECT 3.3-50V SME
C51	*87-010-247-019	CAP, ELECT 100-50 SME	C167	*87-018-123-019	CAP, CERA-SOL SS 220P
C52	*87-010-247-019	CAP, ELECT 100-50 SME	C168	*87-018-123-019	CAP, CERA-SOL SS 220P
C55	*87-010-405-019	CAP, ELECT 10-50V SME	C171	*87-010-260-019	CAP, ELECT 47-25V
C56	*87-010-405-019	CAP, ELECT 10-50V SME	C172	*87-010-260-019	CAP, ELECT 47-25V
C70	*87-010-401-019	CAP, ELECT 1-50V	C171	*87-010-260-019	CAP, ELECT 47-25V
C71	*87-018-131-019	CAP, CERA-SOL SS 1000P	C172	*87-010-260-019	CAP, ELECT 47-25V
C72	*87-010-762-019	CAP, ELECT 220-10 BP	C173	*87-010-404-019	CAP, ELECT 4.7-50V SME
C74	*87-010-403-019	CAP, ELECT 3.3-50V SME	C174	*87-010-404-019	CAP, ELECT 4.7-50V SME
C75	*87-010-260-019	CAP, ELECT 47-25V	C175	*87-018-121-019	CAP, CERA-SOL SS 150P
C81	*87-010-260-019	CAP, ELECT 47-25V	C176	*87-018-121-019	CAP, CERA-SOL SS 150P
C82	*87-010-260-019	CAP, ELECT 47-25V	C177	*87-010-401-019	CAP, ELECT 1-50V
C83	*87-010-401-019	CAP, ELECT 1-50V	C178	*87-010-401-019	CAP, ELECT 1-50V
C84	*87-010-401-019	CAP, ELECT 1-50V	C179	*87-010-404-019	CAP, ELECT 4.7-50V SME
C85	*87-010-756-019	CAP, ELECT 6800-50	C180	*87-010-404-019	CAP, ELECT 4.7-50V SME
			C181	*87-010-260-019	CAP, ELECT 47-25V

For Service Manuals
MAURITRON SERVICES
 8 Cherry Tree Road, Chinnor
 Oxfordshire, OX9 4QY.
 Tel (01844) 351694
 Fax (01844) 352554
 email: mauritron@dfsl.pipex.com

IC BLOCK DIAGRAM

• IC, UPC1237H

REF. NO.	PART NO.	DESCRIPTION
C182	*87-010-260-019	CAP, ELECT 47-25V
LED10	87-001-779-019	LED, SLH56VC RED-F(CD DIRECT IND.)
LED11	87-001-779-019	LED, SLH56VC RED-F(MUTING IND.)
SW10	87-036-179-019	PUSH SW(LOUDNESS)
SW11	87-036-180-019	PUSH SW(CD DIRECT)
SW12	87-036-180-019	PUSH SW(MUTING)
VR1	81-777-630-019	VOLUME 100KB(VOLUME)
VR2	81-777-631-019	VOLUME 100K MN(BALANCE)
VR3	81-777-632-019	VOLUME 50KC(BASS)
VR4	81-777-632-019	VOLUME 50KC(TREBLE)
===SP TERMINAL CIRCUIT BOARD SECTION===		
C223	*87-018-134-019	CAP, CERA-SOL SS 0.01(Z)
C224	*87-018-134-019	CAP, CERA-SOL SS 0.01(Z)
C225	*87-018-134-019	CAP, CERA-SOL SS 0.01(Z)
C226	*87-018-134-019	CAP, CERA-SOL SS 0.01(Z)
C227	*87-018-133-019	CAP, CERA-SOL 4700P(Z)
C228	*87-018-133-019	CAP, CERA-SOL 4700P(Z)
J6	87-033-192-010	SPEAKER TERMINAL 8P(SPEAKERS)
===SP+HP CIRCUIT BOARD SECTION===		
J1	87-009-169-010	JACK 6, 3 STAU(PHONES)
R143	*87-025-458-010	RES, METAL 470-2W
R144	*87-025-458-010	RES, METAL 470-2W
SW8	89-AA1-632-019	PUSH SW(SPEAKER A)
SW9	89-AA1-632-019	PUSH SW(SPEAKER B)
===POWER SW CIRCUIT BOARD SECTION===		
△ C87	*87-033-147-019	FUSE CLAMP(E, K, Z)
△ C87	*87-019-110-019	SPARK KILLER 0.01D(H)
△ C87	*87-019-112-019	CAP, LINE 0.01(E, K, Z)
△ FU3	87-035-366-010	FUSE T2.5A(E, K, Z)
△ SW7	87-036-034-019	PUSH SW(POWER)
===AC VOLTAGE CIRCUIT BOARD SECTION(H MODEL)===		
△	*87-033-147-019	FUSE CLAMP(H)
△ FU5	87-035-365-010	FUSE T2A(H)
△ FU6	87-035-365-010	FUSE T2A(H)
△ SW18	87-036-067-019	SLIDE SW(AC VOLTAGE)(H)
===OUTLET CIRCUIT BOARD SECTION(E, Z MODELS)===		
△	*87-033-147-019	FUSE CLAMP(E, Z)
△ FU4	87-035-366-010	FUSE T2.5A(E, Z)
△ J7	87-049-514-010	AC OUTLET E(AC OUTLET)(E, Z)
===MISCELLANEOUS===		
△	*82-187-796-019	AC CORD (BS)(K)
△	*82-187-797-019	AC CORD (E)(E, Z)
△	*87-034-749-019	AC CORD (H)(H)
△	*87-085-184-010	AC CORD BUSHING D(H)
△	*87-085-185-010	AC CORD BUSHING E(E, K, Z)
△ J7	87-049-416-010	AC OUTLET K-N(AC OUTLET)(K)
△ J7	87-049-017-019	AC OUTLET(AC OUTLET)(H)
△ PT1	89-AA2-608-019	POWER TRANSFORMER E(E, Z)
△ PT1	89-AA2-606-019	POWER TRANSFORMER H(H)
△ PT1	89-AA2-609-019	POWER TRANSFORMER K(K)

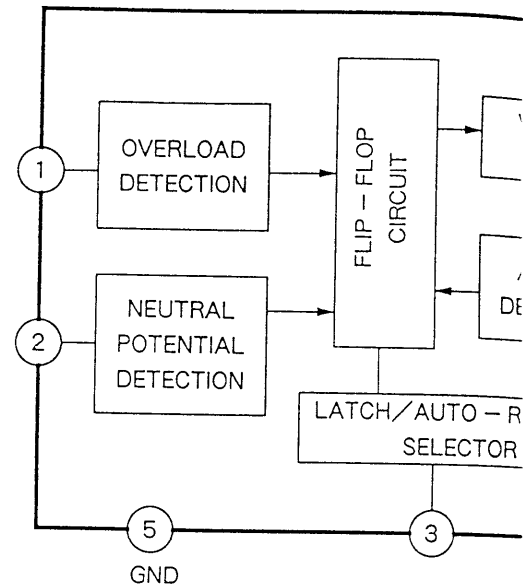

IC BLOCK DIAGRAM

DESCRIPTION
 7-25V
 RED-F(CD DIRECT IND.)
 RED-F(MUTING IND.)
 (DNESS)

• IC, UPC1237H

DIRECT)
 (NG)
 3(VOLUME)
 (BALANCE)
 (BASS)
 (TREBLE)
 ===
 SS 0.01(Z)
 SS 0.01(Z)
 SS 0.01(Z)
 SS 0.01(Z)
 4700P(Z)
 4700P(Z)
 (SPEAKERS)
 (PHONES)
 0-2W
 0-2W
 (KER A)
 (KER B)

(K, Z)
 0.01D(H)
 1(E, K, Z)
 (K, Z)
 (R)
 (H MODEL)===
)
 VOLTAGE)(H)
 MODELS)===
 , Z)
 , Z)
 AC OUTLET)(E, Z)

(K)
 E, Z)
 H)
 (H)
 (E, K, Z)
 (AC OUTLET)(K)
 (H)
 (E, Z)
 (H)
 (H)
 (K)

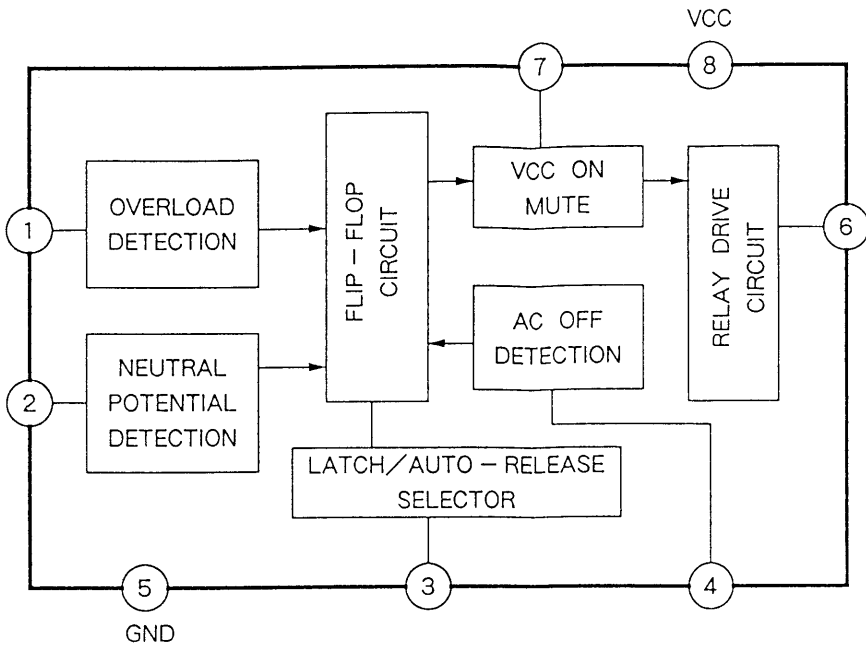

• IC, UPC1225H

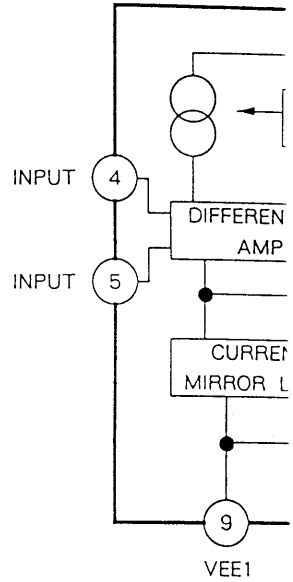

2SA1015
 2SA1264
 2SC2240

2SB
 2SD

• IC, UPC1225H

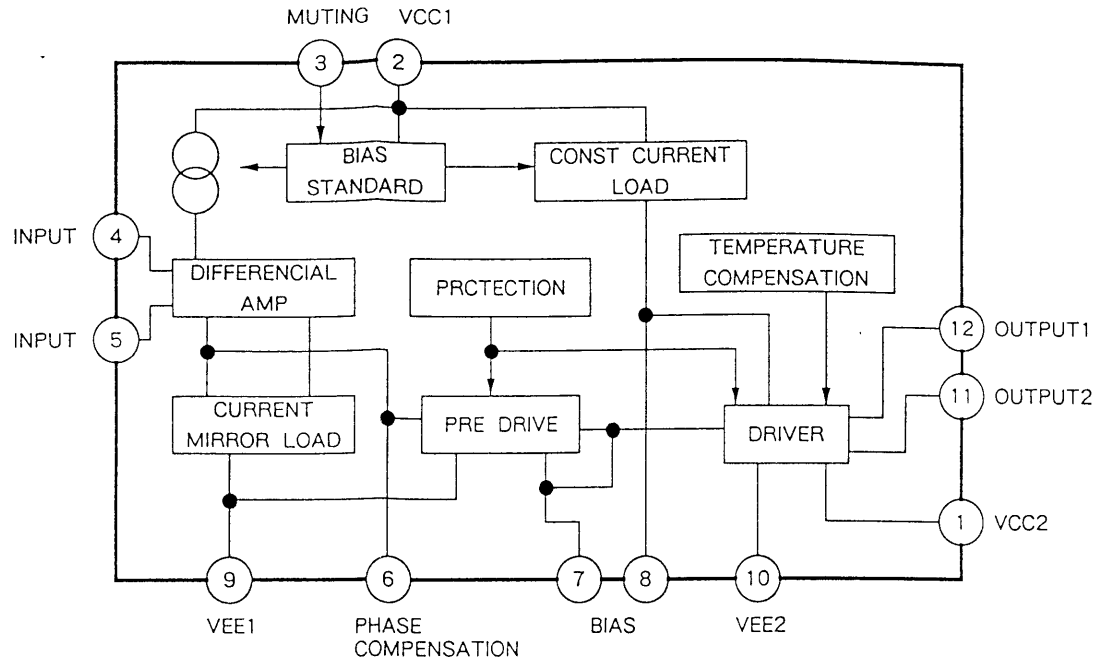
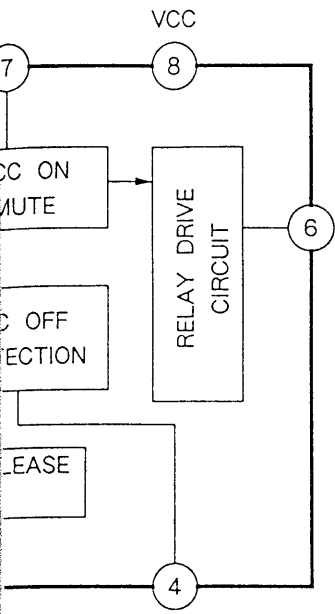

2SA1015
2SA1264
2SC2240

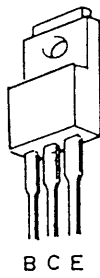

2SB1015
2SD1406



2SC3181



2SC3419

For Service Manuals
MAURITRON SERVICES
8 Cherry Tree Road, Chinnor
Oxfordshire, OX9 4QY.
Tel (01844) 351694
Fax (01844) 352554
email:- mauritron@dial.pipex.com

SCHEMATIC DIAGRAM

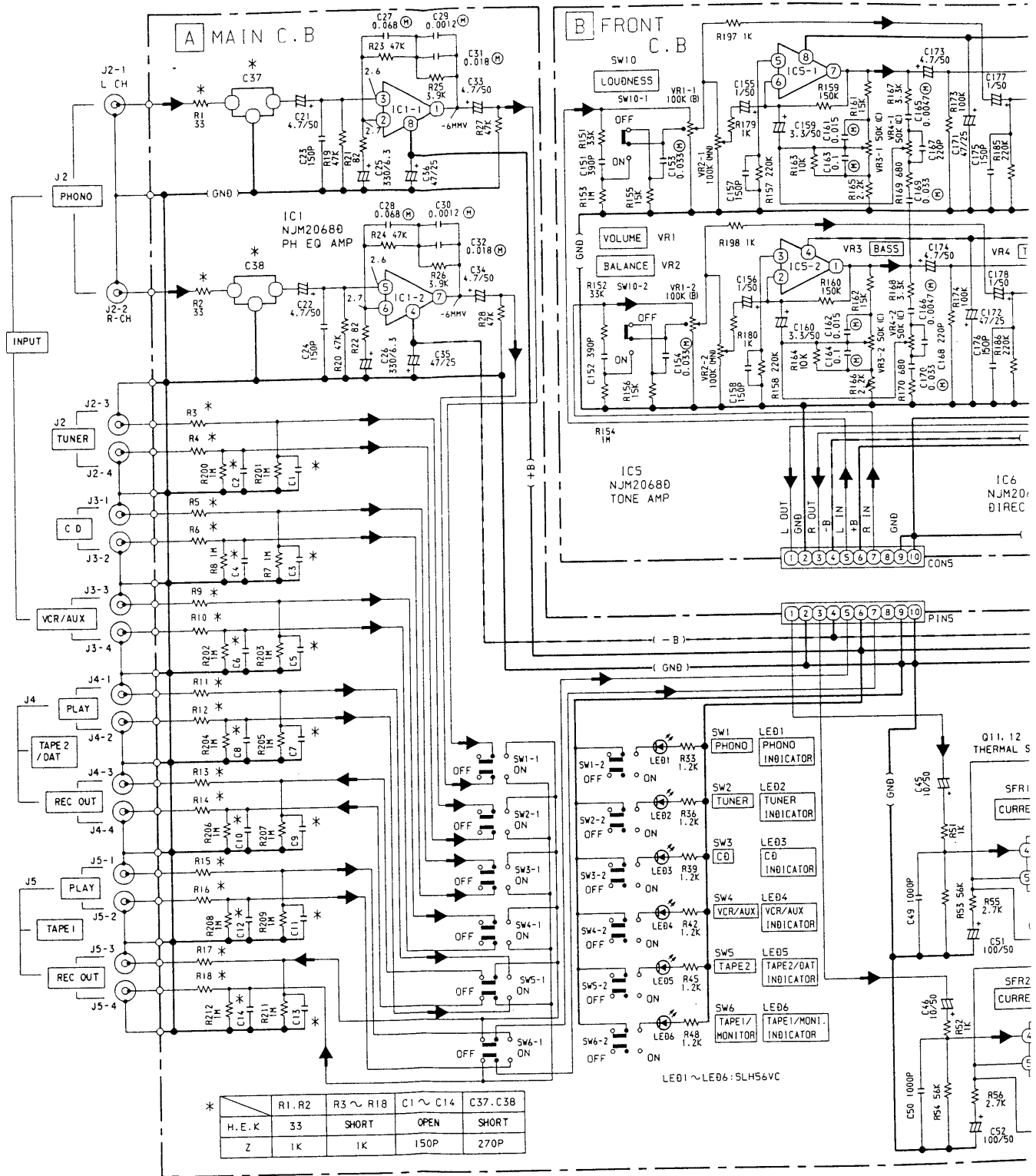

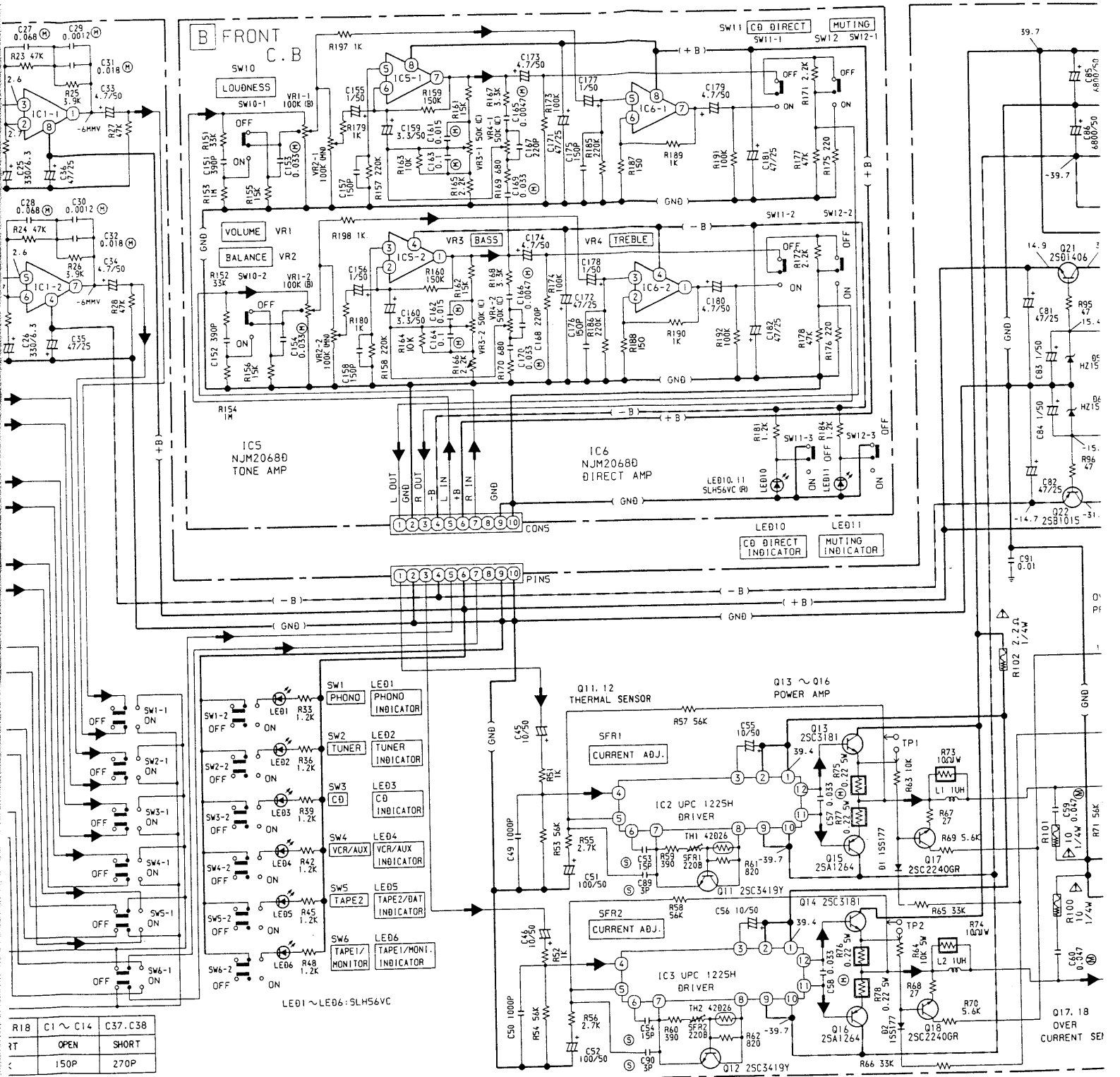

RT	OPEN	SHORT
C	150P	270P

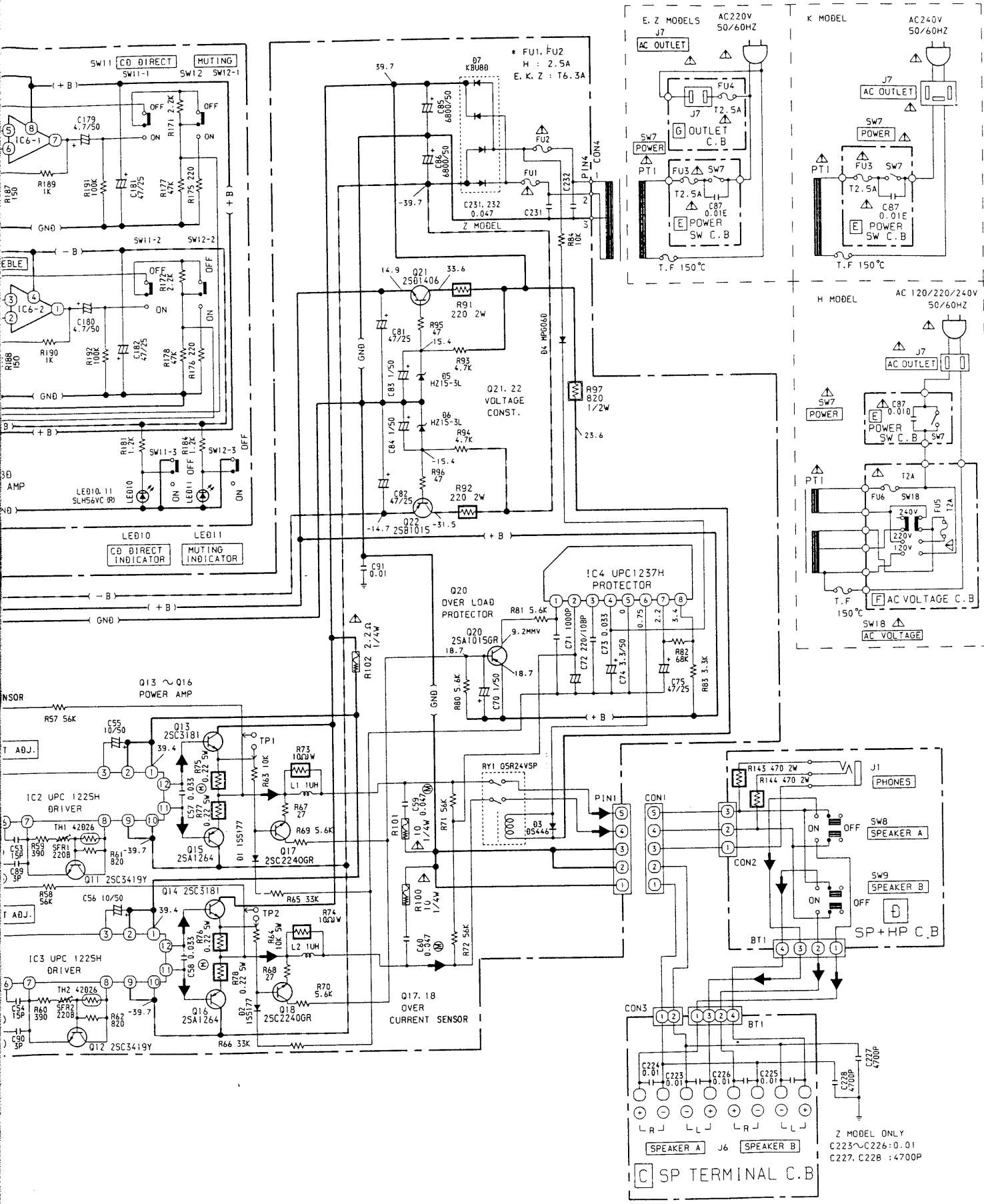

1 2 3 4 5 6 7

A
B
C
D
E
F
G
H

C SP TERMINAL C.B

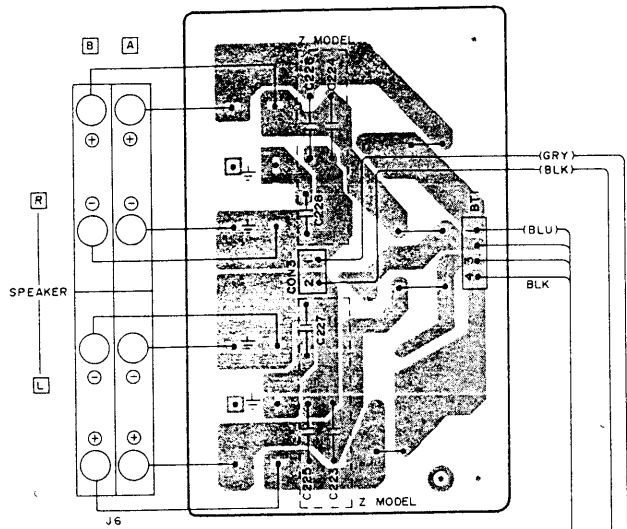

D SP+HP C.B

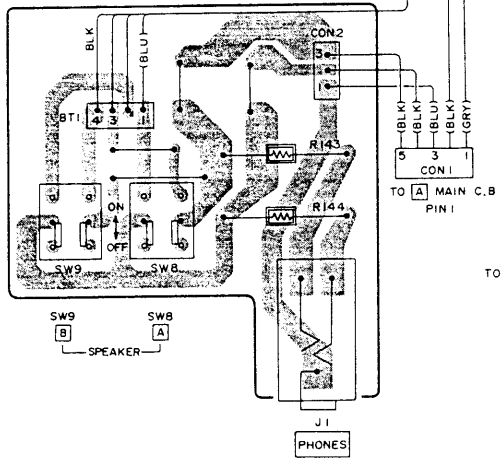

- SW1 PHONO
- LED1 PHONO INDICATOR
- SW2 TUNER
- LED2 TUNER INDICATOR
- SW3 CD
- LED3 CD INDICATOR
- SW4 VCR/AUX
- LED4 VCR/AUX INDICATOR
- SW5 TAPE2/DAT
- LED5 TAPE2/DAT INDICATOR
- SW6 TAPE1/MONITOR
- LED6 TAPE1/MONITOR INDICATOR

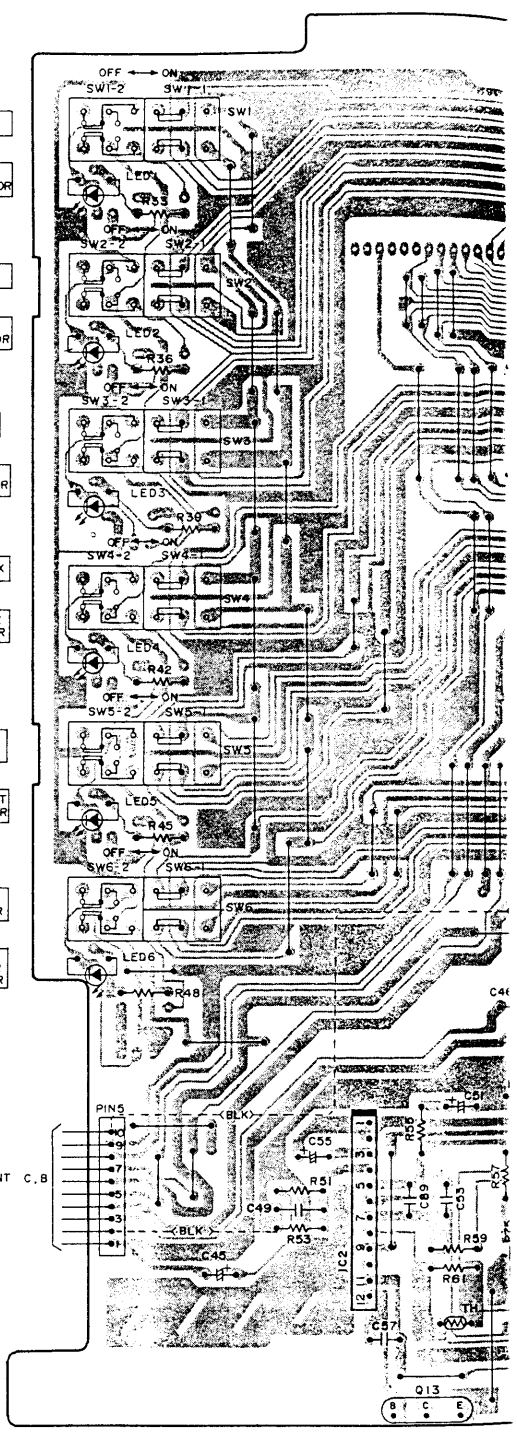

TERMINAL C.B.

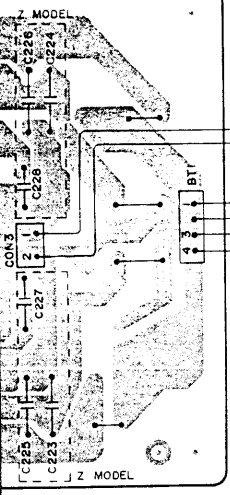

P C.B.

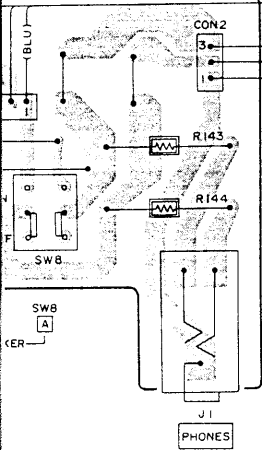

- SW1 PHONO
- LED1 PHONO INDICATOR
- SW2 TUNER
- LED2 TUNER INDICATOR
- SW3 CD
- LED3 CD INDICATOR
- SW4 VCR/AUX
- LED4 VCR/AUX INDICATOR
- SW5 TAPE2/DAT
- LED5 TAPE2/DAT INDICATOR
- SW6 TAPE1/MONITOR
- LED6 TAPE1/MONITOR INDICATOR

TO A MAIN C.B. PIN 1

TO B FRONT CON 5

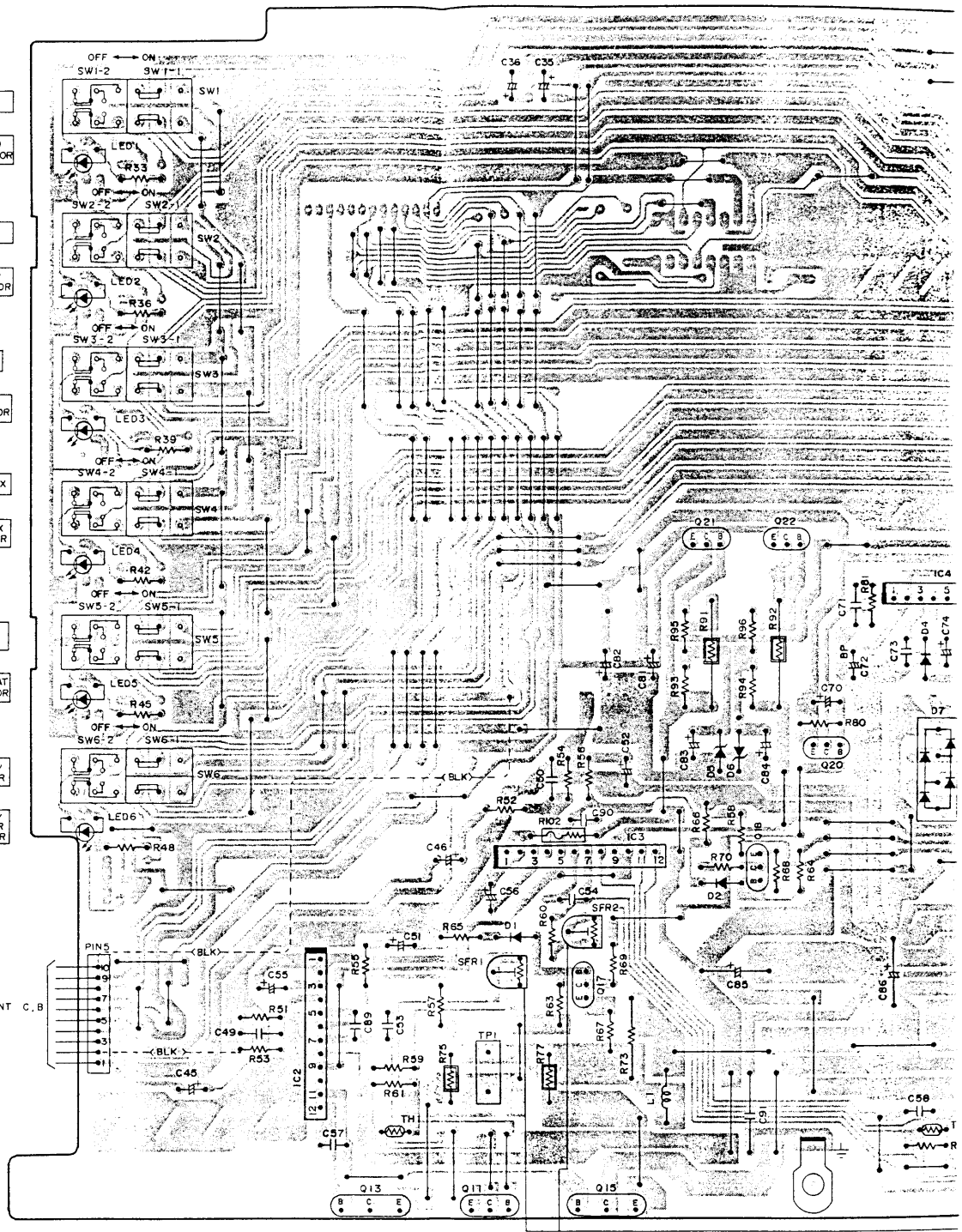

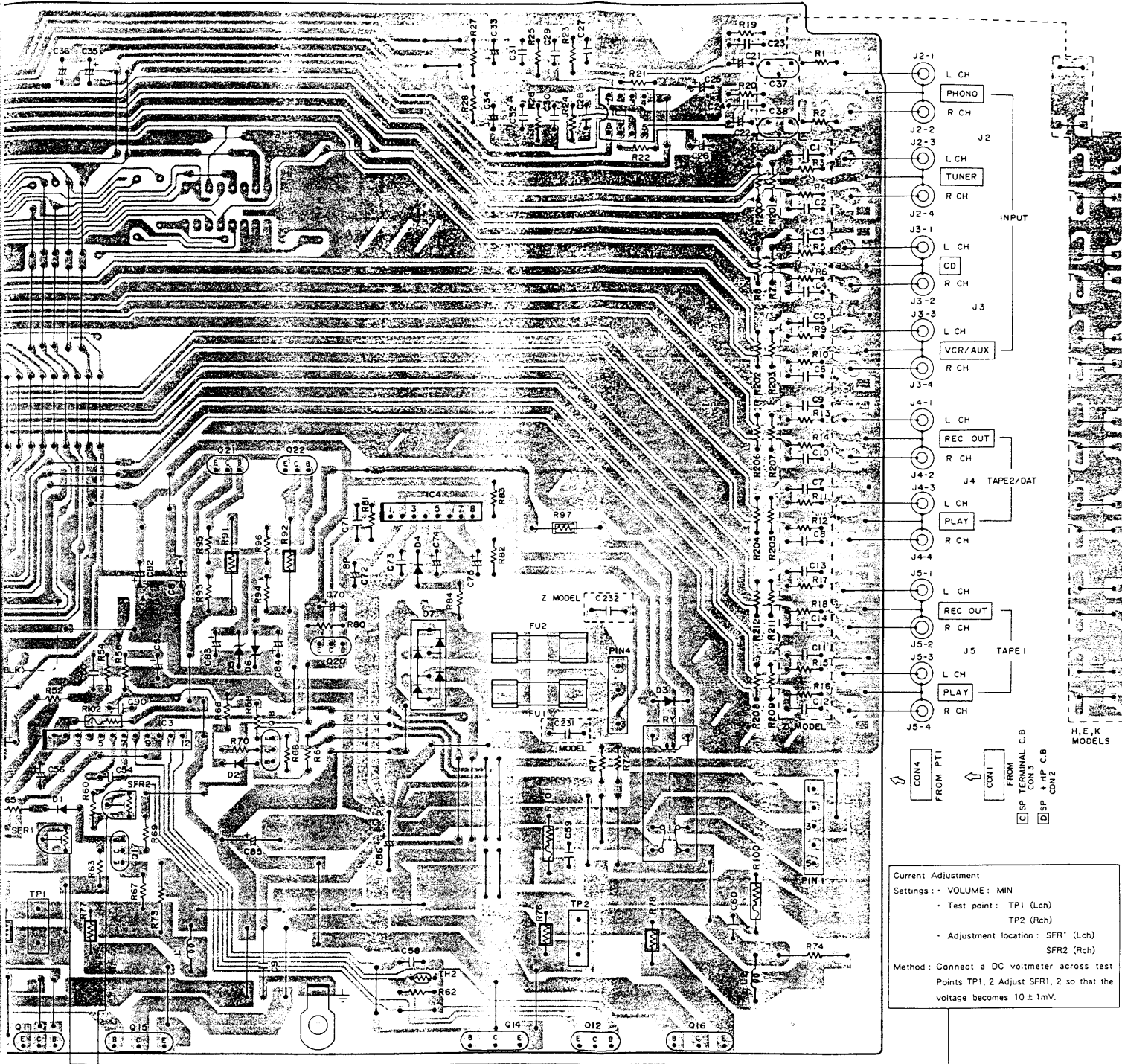

Current Adjustment
 Settings : - VOLUME: MIN
 - Test point : TP1 (Lch)
 TP2 (Rch)
 - Adjustment location : SFR1 (Lch)
 SFR2 (Rch)
 Method : Connect a DC voltmeter across test
 Points TP1, 2 Adjust SFR1, 2 so that the
 voltage becomes 10 ± 1mV.

For Service Manuals
MAURITRON SERVICES
 8 Cherry Tree Road, Chinnor
 Oxfordshire, OX9 4QY.
 Tel (01844) 351694
 Fax (01844) 352554
 email:- mauritron@diat.pipex.com

WIRING - 2

*22.1M
20.1M
1.5M
20.1M*

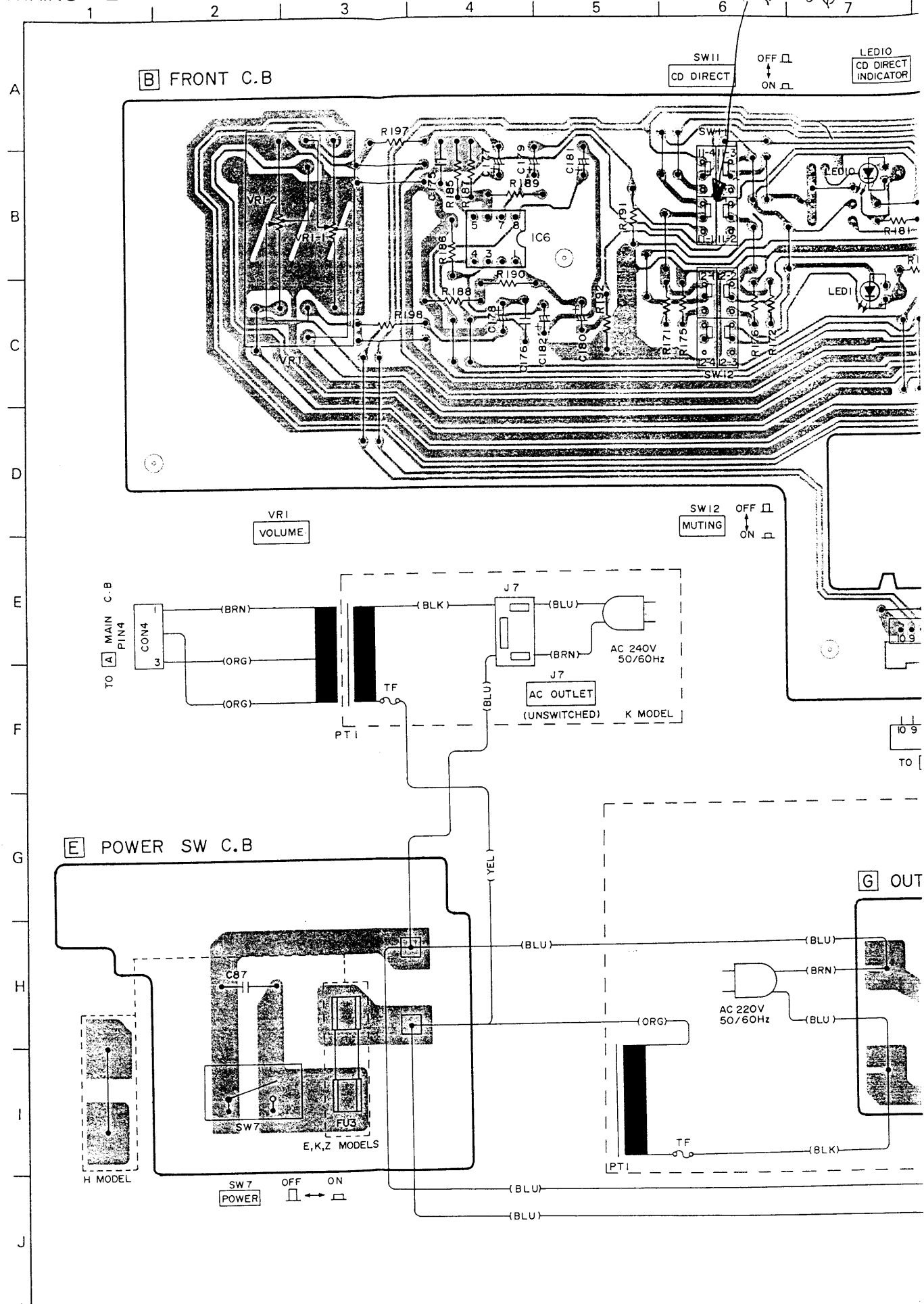

*22m
R181
→ some
R181*

SW11 OFF ON
CD DIRECT

LED10 CD DIRECT INDICATOR

LED11 MUTING INDICATOR

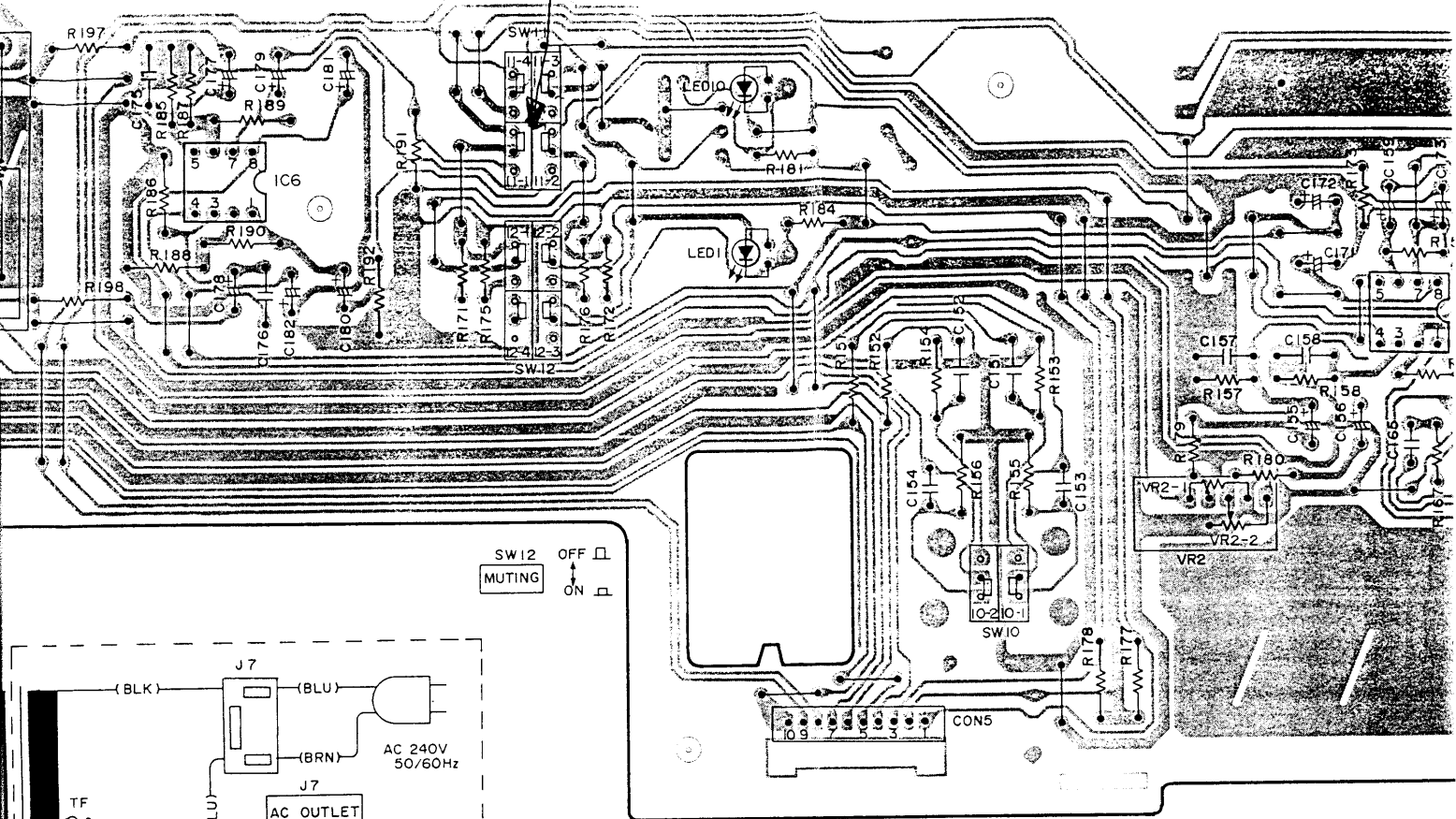

SW12 OFF ON
MUTING

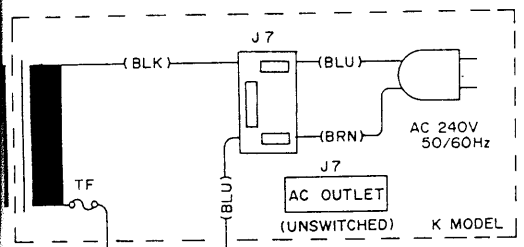

SW10 LOUDNESS
PIN 5 TO MAIN C.B

VR2 BALANCE

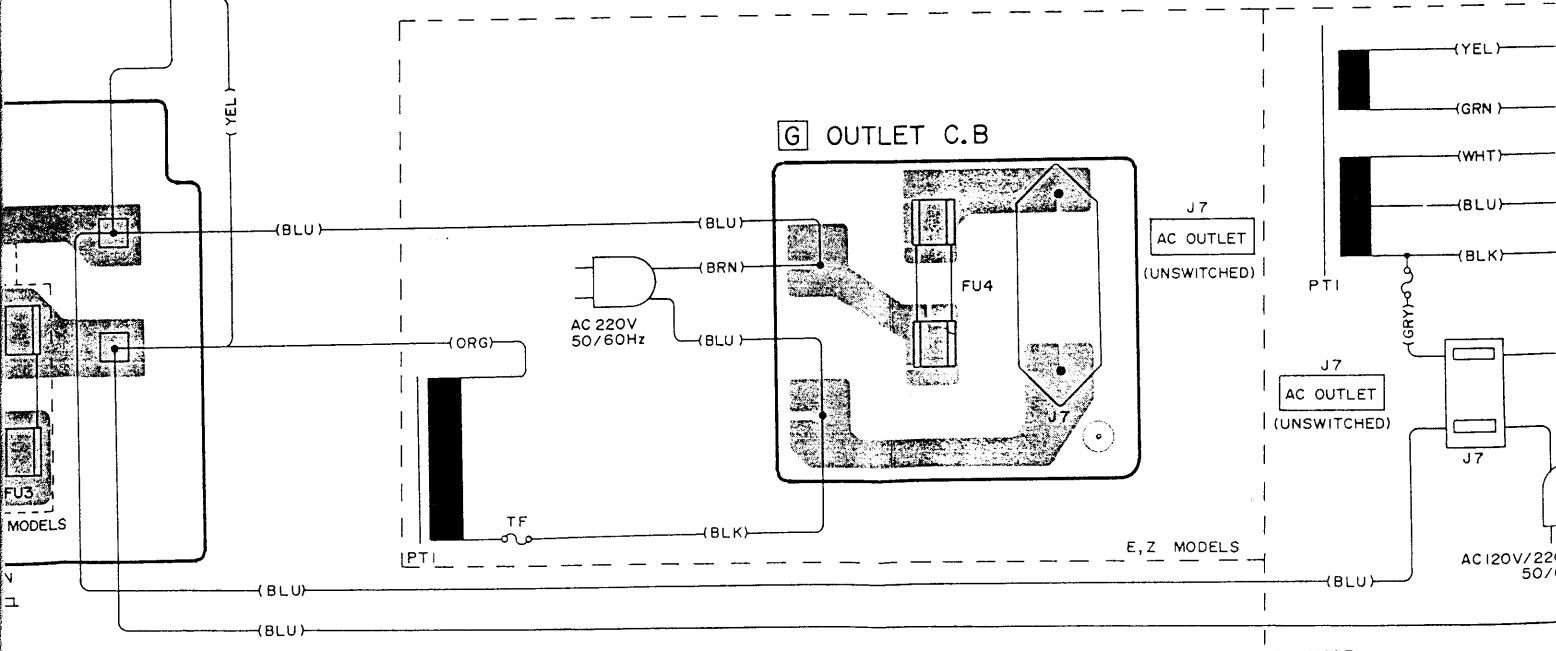

LED11
MUTING
INDICATOR

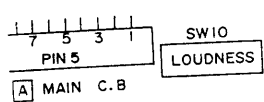
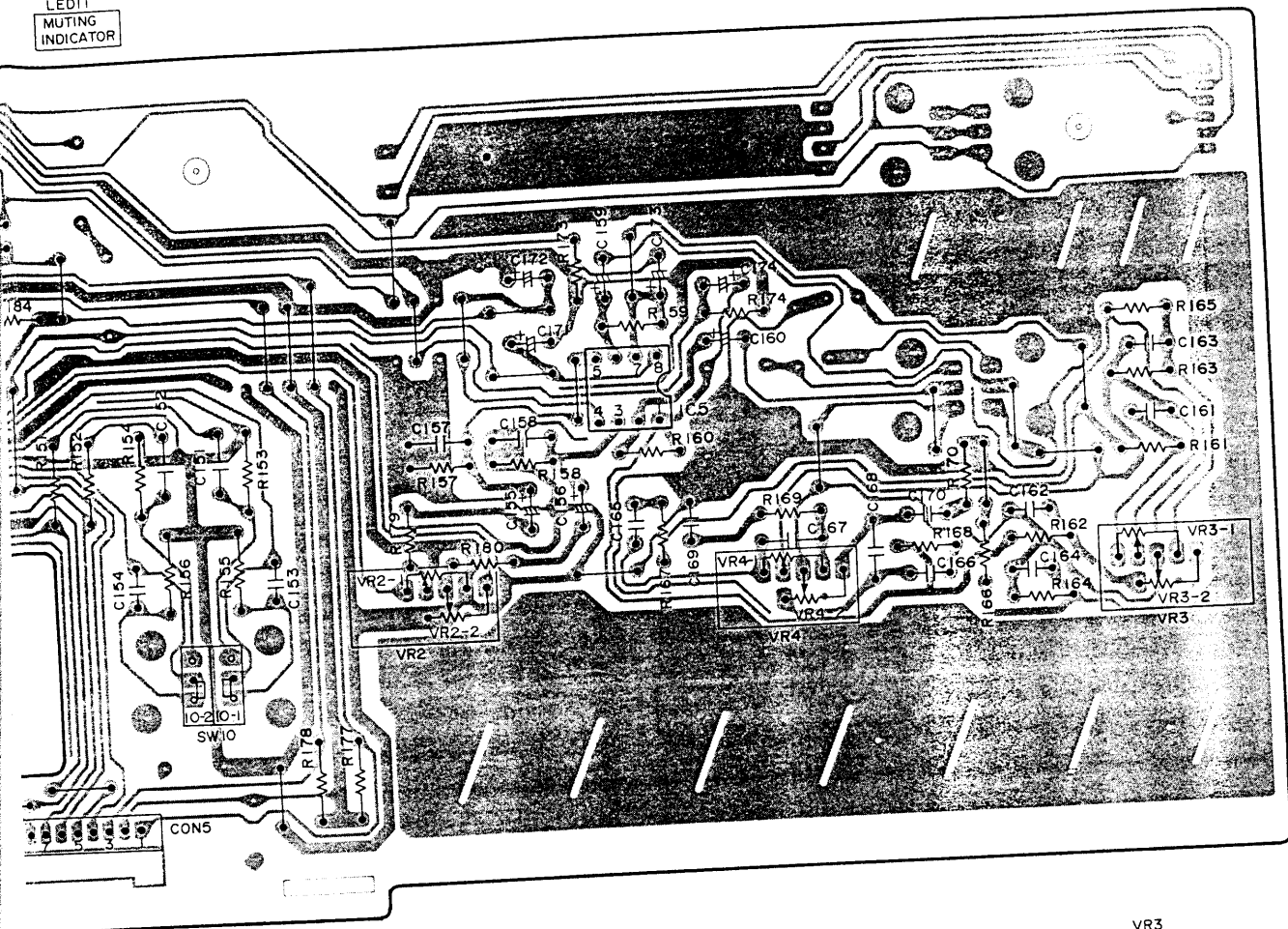

FLET C.B

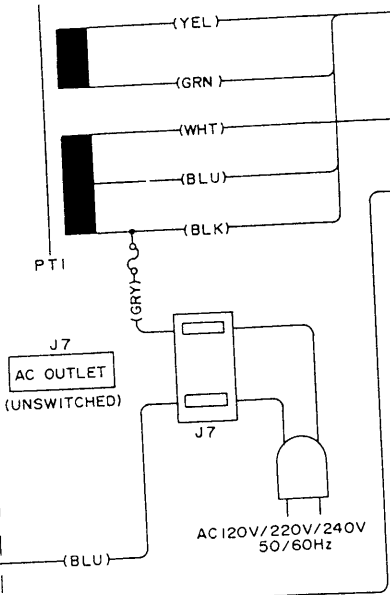
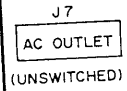
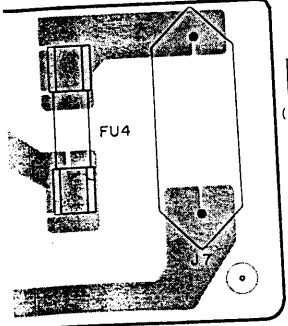

F AC VOLTAGE C.B

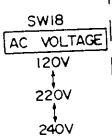
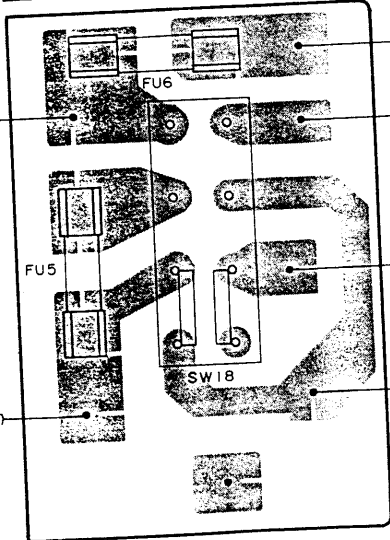

H MODEL

EXPLODED VIEW - 1

REF. NO.	PART NO.	DESCRIPTION
A	87-067-579-01	BVT2+3-8 W/O SLOT
B	87-067-688-01	BVTT+3-6
C	87-067-660-01	BVT2+3-8 W/O SLOT (B)
D	87-591-094-41	QIT+3-6

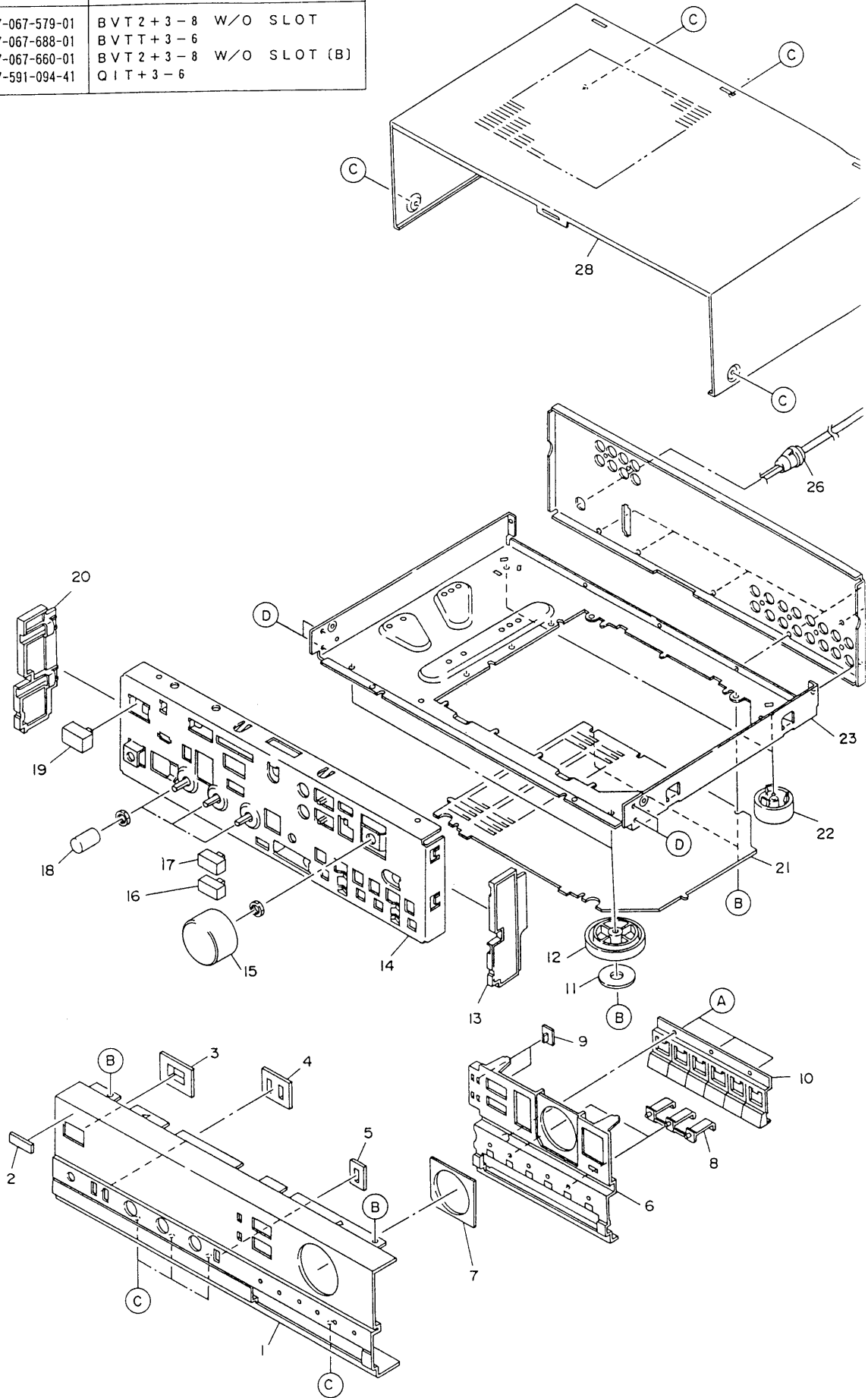

MECHANICAL PARTS LIST

DESCRIPTION
2+3-8 W/O SLOT
T+3-6
2+3-8 W/O SLOT (B)
T+3-6

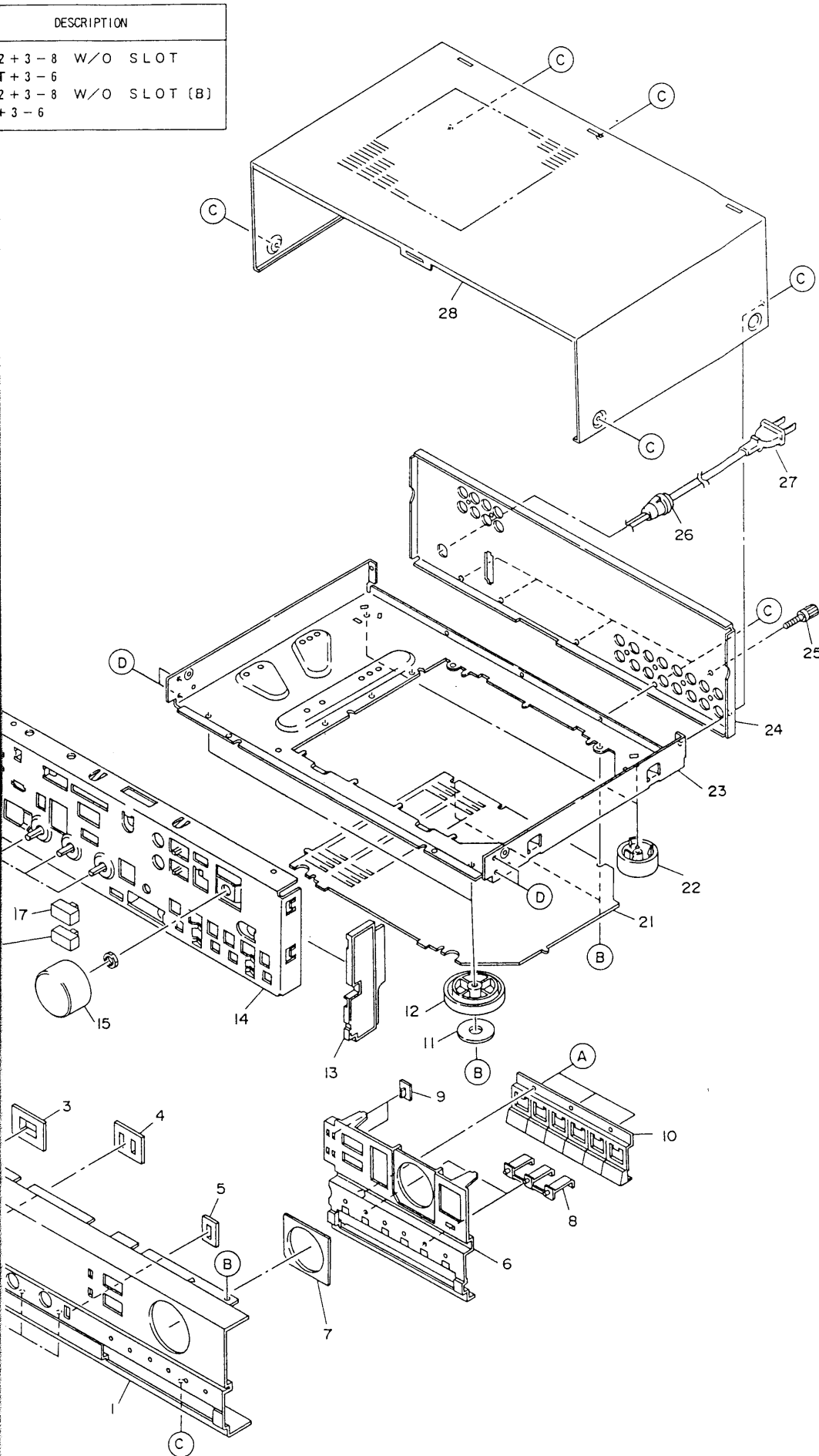

PART NO. CHANGED TO	REF. NO.	PART NO.
	1-1	★89-AA2-001
	1-2	84-764-009
	1-3	★89-AA1-023
	1-4	★89-AA1-026
	1-5	★89-AA1-024
	1-6	★89-AA1-025
	1-7	★89-AA1-020
	1-8	★89-AA1-021
	1-9	★89-AA1-022
	1-10	★89-AA2-006
	1-11	★84-731-027
	1-12	★84-738-022
	1-13	★89-AA1-003
	1-14	---
	1-15	★89-AA1-007
	1-16	★89-AA1-028
	1-17	★89-AA1-012
	1-18	★89-AA1-008
	1-19	★84-721-023
	1-20	★89-AA1-002
	1-21	★89-AA1-207
	1-22	★89-AA1-006
	1-23	---
	1-24	89-AA2-013
	1-24	89-AA2-010
	1-24	89-AA2-012
	1-24	89-AA2-011
	1-24	89-AA2-01C
	1-25	87-033-209
	1-26	★87-085-184
	1-26	★87-085-185
	1-27	★87-034-749
	1-27	★82-187-797
	1-27	★82-187-796
	1-28	★89-AA1-004

MECHANICAL PARTS LIST

PART NO. CHANGED TO	REF. NO.	PART NO.	DESCRIPTION	COMMON MODEL	Q'TY
	1-1	★89-AA2-001-010	PANEL, FR	※	1
	1-2	84-764-009-119	BADGE, AIWA		1
	1-3	★89-AA1-023-019	GUIDE, POWER		1
	1-4	★89-AA1-026-019	GUIDE, LOUD		1
	1-5	★89-AA1-024-019	GUIDE, SPEAKER		1
	1-6	★89-AA1-025-019	HOLDER, FUNCTION		1
	1-7	★89-AA1-020-019	PLATE, VOLUME		1
	1-8	★89-AA1-021-019	GUIDE, LIGHT FUNCTION		2
	1-9	★89-AA1-022-019	GUIDE, LIGHT MUTE		2
	1-10	★89-AA2-006-019	BUTTON, FUNCTION	※	1
	1-11	★84-731-027-010	FELT, FOOT		2
	1-12	★84-738-022-010	FOOT		2
	1-13	★89-AA1-003-019	PANEL, SIDE R		1
	1-14	---	CHASSIS, FR		1
	1-15	★89-AA1-007-019	KNOB, ROTARY VOLUME		1
	1-16	★89-AA1-028-019	BUTTON, MUTE		1
	1-17	★89-AA1-012-019	BUTTON, DIRECT		1
	1-18	★89-AA1-008-019	KNOB, ROTARY BALANCE		3
	1-19	★84-721-023-010	PUSH BUTTON POWER		1
	1-20	★89-AA1-002-019	PANEL, SIDE L		1
	1-21	★89-AA1-207-019	PLATE, BOTTOM		1
	1-22	★89-AA1-006-010	FOOT		2
	1-23	---	CHASSIS, MAIN		1
	1-24	89-AA2-013-019	PANEL, REAR (H)	※	1
	1-24	89-AA2-010-191	PANEL, REAR (HJ)	※	1
	1-24	89-AA2-012-019	PANEL, REAR (E)	※	1
	1-24	89-AA2-011-019	PANEL, REAR (K)	※	1
	1-24	89-AA2-010-019	PANEL, REAR (Z)	※	1
	1-25	87-033-209-01	TERMINAL EARTH		1
	1-26	★87-085-184-019	BUSHING AC CORD (H)		1
	1-26	★87-085-185-019	BUSHING AC CORD (E, K, Z)		1
	1-27	★87-034-749-019	AC CORD (H)		1
	1-27	★82-187-797-019	AC CORD (E, Z)		1
	1-27	★82-187-796-019	AC CORD (K)		1
	1-28	★89-AA1-004-010	CABINET, MAIN STEEL		1

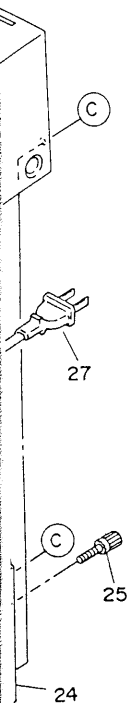

For Service Manuals
MAURITRON SERVICES
 8 Cherry Tree Road, Chinnor
 Oxfordshire, OX9 4QY.
 Tel (01844) 351694
 Fax (01844) 352554
 email:- mauritron@diat.pipex.com

EXPLODED VIEW - 2

REF. NO.	PART NO.	DESCRIPTION
A	87-067-579-01	BVT2+3-8 W/O SLOT
B	87-067-688-01	BVTT+3-6
C	87-067-633-01	BVT2+3-8 W/CONVEX
D	87-067-639-01	BVT2+3-10 W/O SLOT (R)
E	87-067-660-01	BVT2+3-8 W/O SLOT (B)
F	87-067-585-01	BVTT+4-6

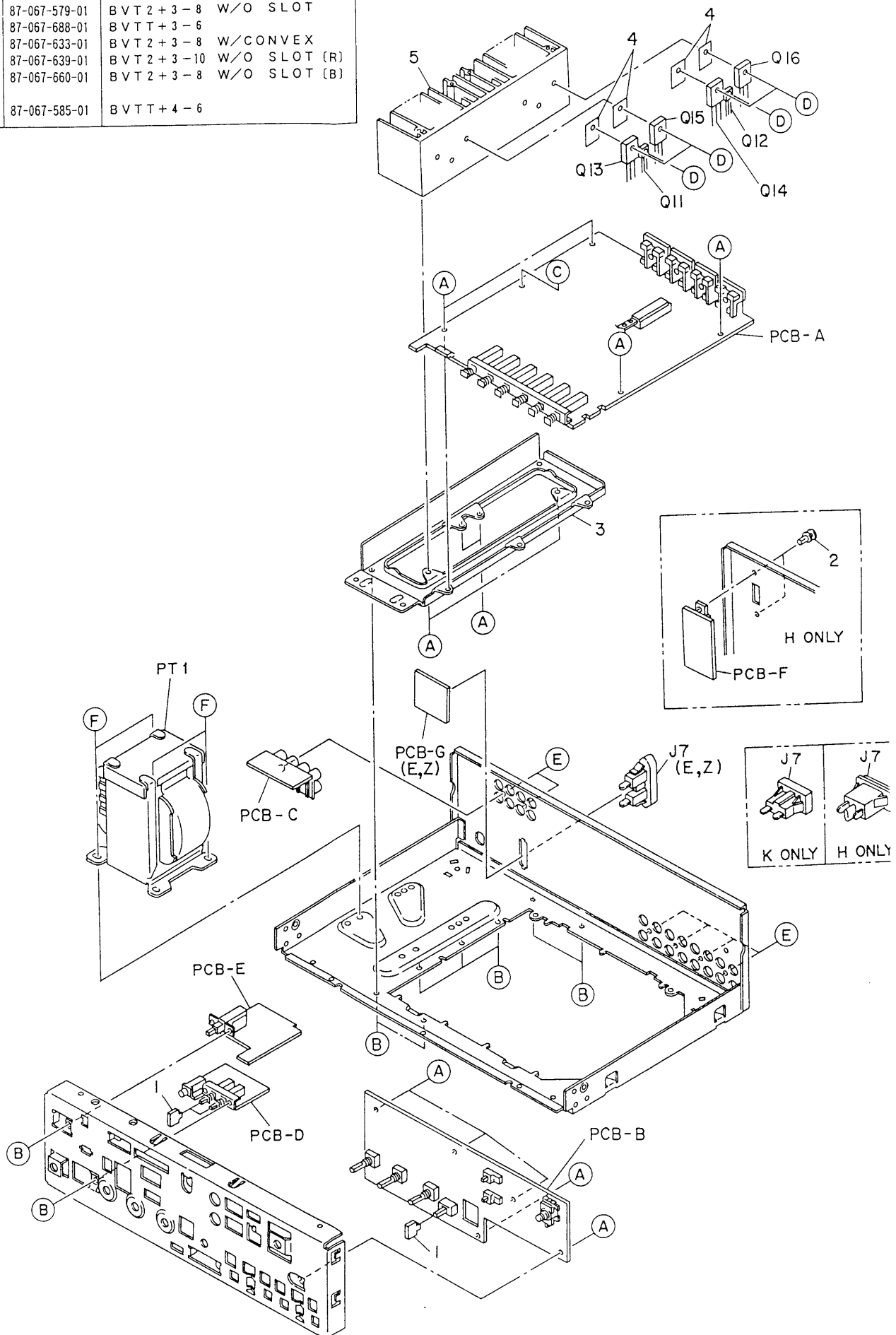

DESCRIPTION
V/O SLOT
V/CONVEX
V/O SLOT (R)
V/O SLOT (B)

PART NO. REF. NO. PART NO.
CHANGED TO

2-1	★89-AA1-011-019
2-2	★87-084-063-019
2-3	---
2-4	89-AA1-602-01
2-5	---

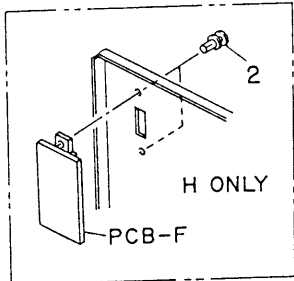
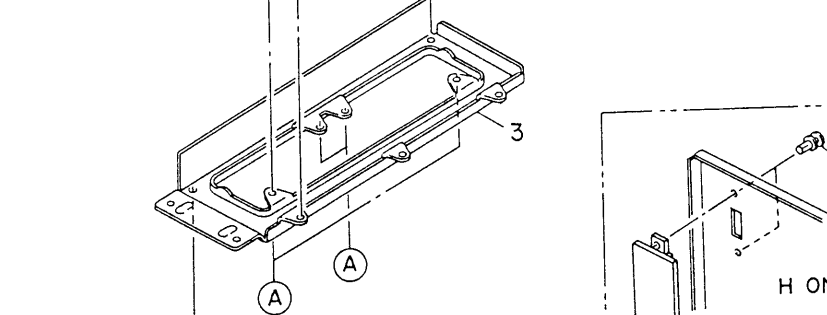
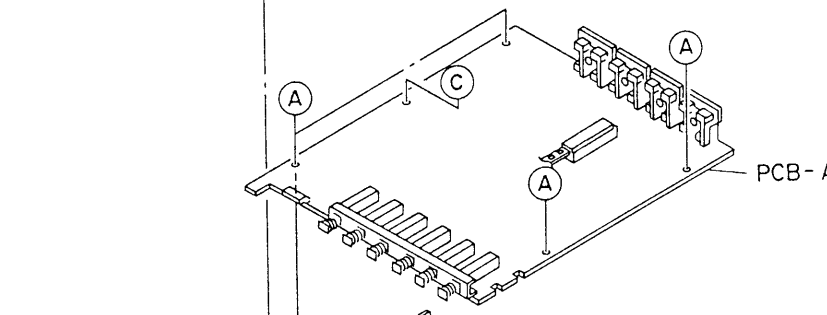
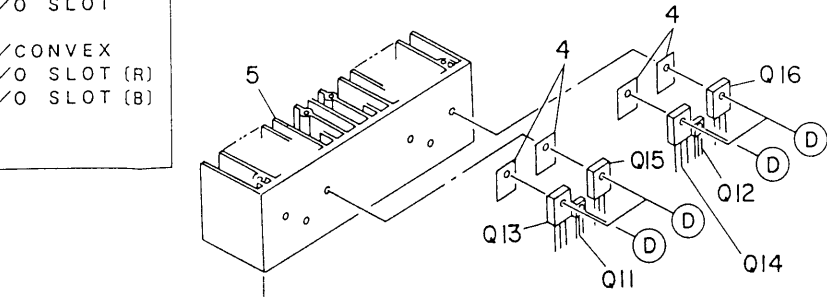

ACCESSORIES/PACKAGE LIST

PART NO. REF. NO. PART NO.
CHANGED TO

1	★89-AA2-911-119
2	★87-032-845-019

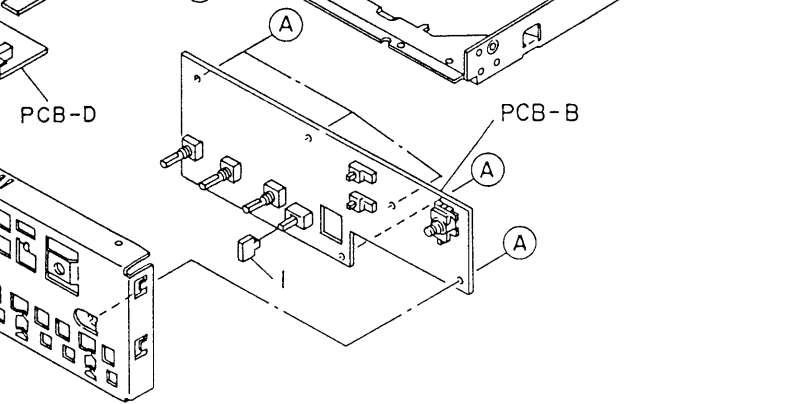
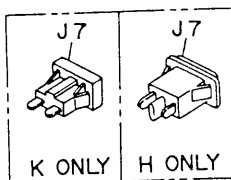
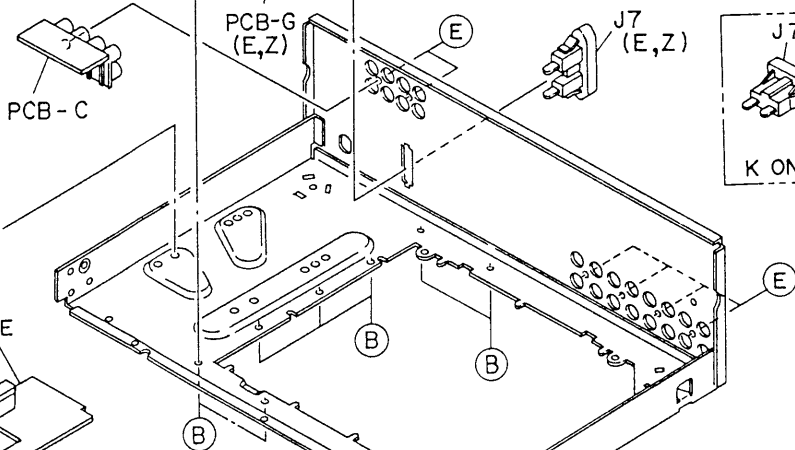

PART NO. CHANGED TO	REF. NO.	PART NO.	DESCRIPTION	COMMON MODEL	Q' TY
	2-1	★89-AA1-011-019	BUTTON, LOUD		3
	2-2	★87-084-063-019	RIVET NYLON 3-5.5		2
	2-3	---	HOLDER, HEET SINK		1
	2-4	89-AA1-602-01	SHEET		4
	2-5	---	HEAT SINK ASSY		1

■ ACCESSORIES/PACKAGE LIST

PART NO. CHANGED TO	REF. NO.	PART NO.	DESCRIPTION	COMMON MODEL	Q' TY
	1	★89-AA2-911-119	INSTRUCTION BOOKLET E/K/Z	※	1
	2	★87-032-845-019	PLUG SIEMENS (H)		1

For Service Manuals
MAURITRON SERVICES
 8 Cherry Tree Road, Chinnor
 Oxfordshire, OX9 4QY.
 Tel (01844) 351694
 Fax (01844) 352554
 email:- mauritron@dial.pipex.com