

aiwa

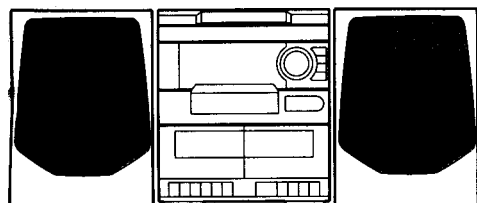

XG-S10 NSX-S9 NSX-S10



COMPACT DISC STEREO
CASSETTE RECEIVER

- BASIC TAPE MECHANISM : TN-21ZSW-1716
- BASIC CD MECHANISM : 4ZG-1 BDLNC
- TYPE : EZ,G (S9)
D,EZ,HR,HS,V (S10)

製品コード : 87NY9 - 0197 (ST)

SYSTEM	CD - CASSEIVER	SPEAKER	REMOTE CONTROLLER
NSX-S9 (TYPE : EZ,G)	CX - NS9	SX - NS10	RC UNIT, 6AS14
XG-S10 (TYPE : D)	CX - NS10		
NSX-S10 (TYPE : EZ,HR,HS,V)			

•If requiring information about the CD mechanism, see Service Manual of 4ZG-1,
S/M Code No. 09-965-128-10T.

MANUAL
SERVICE

TABLE OF CONTENTS

SPECIFICATIONS (D)	3
SPECIFICATIONS (HR,HS)	4
SPECIFICATIONS (9EZ,G,10EZ,V)	5
安全に修理（補修）をするために	6
PROTECTION OF EYES FROM LASER BEAM DURING SERVICING	7
PRECAUTION TO REPLACE OPTICAL BLOCK/光学ブロック (KSS-213B) 交換時の注意	7
ELECTRICAL MAIN PARTS LIST	8 ~ 10
TRANSISTOR ILLUSTRATION	11
IC BLOCK DIAGRAM - 1	12
BLOCK DIAGRAM - 1 (MAIN / FRONT : EXCEPT 10EZ)	13, 14
BLOCK DIAGRAM - 2 (MAIN / FRONT : 10EZ)	15, 16
WIRING - 1 (MAIN : D)	17, 18
SCHEMATIC DIAGRAM - 1 (MAIN : D)	19 ~ 21
SCHEMATIC DIAGRAM - 2 (MAIN : HR)	22 ~ 24
WIRING - 2 (MAIN : HR)	25, 26
WIRING - 3 (MAIN : HS)	27, 28
SCHEMATIC DIAGRAM - 3 (MAIN : HS)	29 ~ 31
SCHEMATIC DIAGRAM - 4 (MAIN : 9EZ,G)	32 ~ 34
WIRING - 4 (MAIN : 9EZ,G)	35, 36
WIRING - 5 (MAIN : V)	37, 38
SCHEMATIC DIAGRAM - 5 (MAIN : V)	39 ~ 41
SCHEMATIC DIAGRAM - 6 (MAIN : 10EZ)	42 ~ 44
WIRING - 6 (MAIN : 10EZ)	45, 46
WIRING - 7 (FRONT : EXCEPT 10EZ)	47, 48
SCHEMATIC DIAGRAM - 7 (FRONT : EXCEPT 10EZ)	49, 50
WIRING - 8 (FRONT : 10EZ)	51, 52
SCHEMATIC DIAGRAM - 8 (FRONT : 10EZ)	53, 54
WIRING - 9 (AC)	55
WIRING - 6 (DECK)	56
IC BLOCK DIAGRAM - 2	57, 58
FL GRID ASSIGNMENT & ANODE CONNECTION (EXCEPT 10EZ)	59
FL GRID ASSIGNMENT & ANODE CONNECTION (10EZ)	60
IC DESCRIPTION (D)	61,62
IC DESCRIPTION (EXCEPT D)	63 ~ 66
ADJUSTMENT-1<TUNER / DECK : D>	67, 68
ADJUSTMENT-1<TUNER / DECK : EXCEPT D>	69 ~ 72
PRACTICAL SERVICE FIGURE	73, 74
ACCESSORIES / PACKAGE LIST	74
MECHANICAL EXPLODED VIEW 1 / 1	75, 76
MECHANICAL PARTS LIST 1 / 1	77
TAPE MECHANISM EXPLODED VIEW 1 / 2	78
TAPE MECHANISM PARTS LIST 1 / 2	79
TAPE MECHANISM EXPLODED VIEW 2 / 2	80
TAPE MECHANISM PARTS LIST 2 / 2	81
SPEAKER DISASSEMBLY INSTRUCTIONS	82
SPEAKER PARTS LIST	82
REFERENCE NAME LIST	83

SPECIFICATIONS (HR,HS)

<FM Tuner section>

Tuning range 87.5 MHz to 108 MHz
Usable sensitivity (IHF) 16.8 dBf
Antenna terminals 75 ohms (unbalanced)

<MW Tuner section> (HR)

Tuning range 531 kHz to 1602 kHz (9 kHz step)
 530 kHz to 1710 kHz (10 kHz step)
Usable sensitivity 350 μ V/m
Antenna Loop antenna

<SW Tuner section> (HR)

Tuning range 5.9000 MHz - 17.900 MHz
Antenna Wire antenna

<AM Tuner section> (HS)

Tuning range 531 kHz to 1602 kHz (9 kHz step)
Usable sensitivity 350 μ V/m
Antenna Loop antenna

<Amplifier section>

Power output Rated: 12 W +12 W (T.H.D.1 %, 6 ohms,1 kHz)
 Reference: 15 W +15 W(T.H.D 10 %, 6 ohms,1 kHz)
Total harmonic distortion 0.3 % (6 W, 1 kHz, 6 ohms, DIN AUDIO)
Inputs VIDEO/AUX: 400 mV
Outputs SPEAKERS: accept speakers of 6 ohms or more
 PHONES (stereo jack) : accepts headphones of 32 ohms or more

<Cassette deck section>

Track format 4 tracks, 2 channels stereo
Frequency response 50 Hz - 10000 Hz
Recording system AC bias
Heads Deck 1 : Recording/playback/ erase head x 1
 Deck 2 : Playback head x 1

<Compact disc player section>

Laser Semiconductor laser ($\lambda = 780$ nm)
D-A converter 1 bit dual
Signal-to-noise ratio 90 dB (1 kHz, 0 dB)
Harmonic distortion 0.03% (1 kHz, 0 dB)
Wow and flutter Unmeasurable

<Speaker system SX-NS10>

Cabinet type 2 way, bass reflex (magnetic shielded type)
Speakers Woofer : 120 mm cone type
 Tweeter : 10 mm ceramic type
Impedance 6 ohms
Output sound pressure level 87 dB/W/m
Dimensions (W x H x D) 220 x 302 x 238 mm
Weight 2.5 kg (5lbs 8 oz)

<General>

Power requirements HR: 120 V/220 V-240 V AC, (switchable) 50/60 Hz
 HS: 220V AC, 60 Hz
Power consumption HR: 50 W
 HS: 75 W
Dimensions of main unit (W x H x D) 260 x 308 x 335 mm
Weight of main unit 4.4 kg

• Design and specifications are subject to change without notice.

SPECIFICATIONS (9EZ,G,10EZ,V)

<FM Tuner section> (9EZ,10EZ,9G)

Tuning range 87.5 MHz to 108 MHz
Usable sensitivity (IHF) 16.8 dBf
Antenna terminals 75 ohms (unbalanced)

<FM Tuner section> (V)

Tuning range FM1 (OIRT)
 65 MHz to 74 MHz (10 kHz step)
 FM2 (CCIR)
 87.5 MHz to 108 MHz (50 kHz step)
Antenna terminals Wire antenna

<MW Tuner section>

Tuning range 531 kHz to 1602 kHz (9 kHz step)
 530 kHz to 1710 kHz (10 kHz step)
Usable sensitivity 350 μ V/m
Antenna Loop antenna

<LW Tuner section>

Tuning range 144 kHz to 290 kHz
Usable sensitivity 1400 μ V/m
Antenna Loop antenna

<Amplifier section>

Power output Rated: 12 W +12 W (T.H.D.1 %, 6 ohms 1 kHz/DIN 45500)
 Reference: 15 W + 15 W (6 ohms, T.H.D. 10%, 1 kHz/DIN 45324)
 DIN MUSIC POWER
 35 W + 35W

Total harmonic distortion 0.3 % (6 W, 1 kHz, 6 ohms, DIN AUDIO)

Inputs VIDEO/AUX: 400 mV
Outputs SPEAKERS: accept speakers of 6 ohms or more
 PHONES (stereo jack) : accepts headphones of 32 ohms or more

<Cassette deck section>

Track format 4 tracks, 2 channels stereo
Frequency response 50 Hz - 10000 Hz
Recording system AC bias
Heads Deck 1 : Recording/playback/erase head x 1
 Deck 2 : Playback head x 1

<Compact disc player section>

Laser Semiconductor laser ($\lambda = 780$ nm)
D-A converter 1 bit dual
Signal-to-noise ratio 90 dB (1 kHz, 0 dB)
Harmonic distortion 0.03% (1 kHz, 0 dB)
Wow and flutter Unmeasurable

<Speaker system SX-NS10>

Cabinet type 2 way, bass reflex (magnetic shielded type)
Speakers Woofer : 120 mm($4\frac{3}{4}$ in.) cone type
 Tweeter : 10 mm($1\frac{3}{32}$ in.) ceramic type
Impedance 6 ohms
Output sound pressure level 87 dB/W/m
Dimensions (W x H x D) 220 x 302 x 238 mm ($8\frac{3}{4}$ x 12 x $9\frac{3}{8}$ in.)
Weight 2.5 kg (5 lbs 8oz)

<General>

Power requirements 230 V AC, 50 Hz
Power consumption 80 W
Dimensions of main unit (W x H x D) 260 x 308 x 335 mm ($10\frac{1}{4}$ x $12\frac{1}{4}$ x $13\frac{1}{4}$ in.)
Weight of main unit 4.4 kg (9 lbs 11oz)

• Design and specifications are subject to change without notice.

PROTECTION OF EYES FROM LASER BEAM DURING SERVICING

This set employs laser. Therefore, be sure to follow carefully the instructions below when servicing.

WARNING!!

WHEN SERVICING, DO NOT APPROACH THE LASER EXIT WITH THE EYE TOO CLOSELY. IN CASE IT IS NECESSARY TO CONFIRM LASER BEAM EMISSION. BE SURE TO OBSERVE FROM A DISTANCE OF MORE THAN 30cm FROM THE SURFACE OF THE OBJECTIVE LENS ON THE OPTICAL PICK-UP BLOCK.



- Caution: Invisible laser radiation when open and interlocks defeated avoid exposure to beam.
- Advarsel: Usynlig laserstråling ved åbning, når sikkerhedsafbrydere er ude af funktion. Undgå udsættelse for stråling.

VAROITUS!

Laiteen Käyttäminen muulla kuin tässä käyttöohjeessa mainitulla tavalla saattaa altistaa käyt-täjän turvallisuusluokan 1 ylittävälle näkymättömälle lasersäteilylle.

WARNING!

Om apparaten används på annat sätt än vad som specificeras i denna bruksanvising, kan användaren utsättas för osynlig laserstrålning, som överskrider gränsen för laserklass 1.

CAUTION

Use of controls or adjustments or performance of procedures other than those specified herein may result in hazardous radiation exposure.

ATTENTION

L'utilisation de commandes, réglages ou procédures autres que ceux spécifiés peut entraîner une dangereuse exposition aux radiations.

ADVARSEL

Usynlig laserstråling ved åbning, når sikkerhedsafbrydere er ude af funktion. Undgå udsættelse for stråling.

This Compact Disc player is classified as a CLASS 1 LASER product.

The CLASS 1 LASER PRODUCT label is located on the rear exterior.

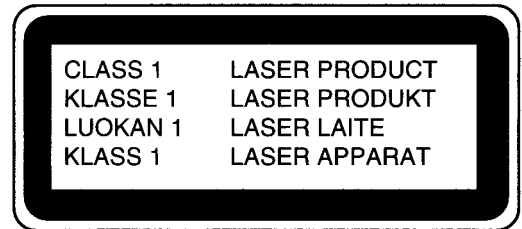

Precaution to replace Optical block (KSS – 213B)

Body or clothes electrostatic potential could ruin laser diode in the optical block. Be sure ground body and workbench, and use the clothes do not touch the diode.

- 1) After the connection, remove solder shown in right figure.

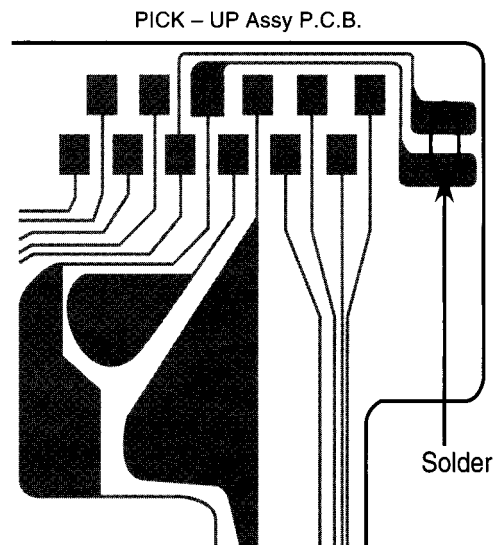

ELECTRICAL MAIN PARTS LIST

If can't understand for Description please kindly refer to "REFERENCE NAME LIST"

REF. NO.	PART NO.	KANRI NO.	DESCRIPTION	REF. NO.	PART NO.	KANRI NO.	DESCRIPTION
IC				C151	87-018-134-080		CAP,TC U 0.01-16YN<10EZ,9EZ,V,G>
	86-NFZ-701-010	--	IC,UPD78044HGF-021-3B9<EXP 10EZ>	C200	87-018-211-080		CAP,TC U 0.01-50<10EZ,9EZ,G>
	86-NFZ-706-010		IC,UPD78045HGF-017-3B9<10EZ>	C201	87-010-545-080	OE	CAP,E 0.22-50 SME
	87-A20-593-010	1B	IC,SPS-442-1-A	C202	87-010-545-080	OE	CAP,E 0.22-50 SME
	87-A20-754-010	--	IC,BA4558N-DX	C203	87-018-199-089	--	CAP,CER 3300P
	87-017-804-010	1B	IC,BU4052BC				
	87-A20-312-010	--	IC,M62420SP	C204	87-018-199-089	--	CAP,CER 3300P
	87-A20-502-010		IC,BU1920<10EZ>	C205	87-018-199-089	--	CAP,CER 3300P<D,HR,HS>
	86-NFZ-655-010	1C	IC,LC72131D(Z)	C205	87-018-196-080		CAP,CER 1500P<10EZ,9EZ,V,G>
	86-NFZ-654-010	--	IC,LA1836(Z)	C206	87-018-199-089	--	CAP,CER 3300P<D,HR,HS>
	87-017-914-010		IC,BU4094<10EZ>	C206	87-018-196-080		CAP,CER 1500P<10EZ,9EZ,V,G>
	87-017-300-010		IC,NJM2100L<10EZ>				
	87-002-641-010	--	IC,TA8124P<D>	C207	87-010-545-080	OE	CAP,E 0.22-50 SME
				C208	87-010-545-080	OE	CAP,E 0.22-50 SME
				C209	87-010-221-080	--	CAP,E 470-10 SME
				C210	87-010-221-080	--	CAP,E 470-10 SME
				C211	87-018-024-080		CAP,TCU 47P-50J SL<10EZ,9EZ,V,G>
TRANSISTOR				C212	87-018-024-080		CAP,TCU 47P-50J SL<10EZ,9EZ,V,G>
	89-213-702-010	1A	TR,2SB1370E	C213	87-018-104-080		CAP,TCU 10P-50J SL<10EZ,9EZ,V,G>
	87-026-610-080	OE	TR,KTC3198GR	C214	87-018-104-080		CAP,TCU 10P-50J SL<10EZ,9EZ,V,G>
	87-026-609-080	OE	TR,KTA1266GR	C219	87-010-544-080	--	CAP,E 0.1-50 SME
	87-026-286-080	OE	TR,DTA143ES	C220	87-010-544-080	--	CAP,E 0.1-50 SME
	87-026-214-080	OE	TR,DTA114YS				
	89-420-612-010	--	TR,2SD2061E	C221	87-018-134-080		CAP,TCU 0.01-16 NY<10EZ,9EZ,V,G>
	87-026-218-080	--	TR,DTC144ES	C222	87-018-134-080		CAP,TCU 0.01-16 NY<10EZ,9EZ,V,G>
	87-026-292-080	--	TR,DTA144WS	C225	87-016-586-080	--	CAP,E 470-25 M SSL
	89-406-555-080	OE	TR,2SD655E	C226	87-010-408-089	OE	CAP,E 47-50 SME
	87-026-289-080	--	TR,DTC143XS	C227	87-010-405-080	OE	CAP,E 10-50 SME
	87-A30-092-080	--	FET,2SK439E/F				
	89-305-352-380	--	TR,2SC535(B/C)	C292	87-018-134-080		CAP,TCU 0.01-16 NY<10EZ,9EZ,V,G>
	89-319-233-080	OE	TR,2SC19230<HR,D,HS>	C300	87-018-209-080	OE	CAP,CER 0.1-50<D,HR,HS>
	89-320-011-080		TR,2SC2001K<EXP D,HS>	C300	87-018-134-080		CAP,TC U 0.01-16 NY<10EZ,9EZ,G>
	87-026-269-080		TR,DTA114ES<EXP D>	C301	87-018-195-080	--	CAP,CER 1200P-16V
				C302	87-018-195-080	--	CAP,CER 1200P-16V
	87-026-462-080		TR,2SC1740SRS<HR>				
	87-026-463-080		TR,2SA933SRS<HR>	C303	87-010-263-080	OE	CAP,E 100-10 SME
	89-A30-083-080	OE	TR,CSD1489B	C304	87-010-263-080	OE	CAP,E 100-10 SME
	87-026-215-080	--	TR,DTC114YS<D,10EZ>	C309	87-010-546-080	--	CAP,E 0.33-50 SME
	87-026-219-080	--	TR,DTA144ES<D>	C310	87-010-546-080	--	CAP,E 0.33-50 SME
	86-NFZ-658-080		TR,2SC2785F<EXP D,HS>	C311	87-018-130-080	--	CAP,TC U 820P-50 K B UP050
DIODE				C312	87-018-130-080	--	CAP,TC U 820P-50 K B UP050
	87-070-178-090	--	DIODE,1N5402	C314	87-010-260-040	OE	CAP,E 47-25 SME
	87-070-274-080	OE	DIODE,1N4003 SEM	C345	87-018-115-080		CAP,TCU 47P-50J SL<10EZ,9EZ,V,G>
	87-A40-309-080	--	ZENER,DZ24M	C349	87-018-209-080		CAP,TCU 0.1-50 ZF<10EZ,9EZ,V,G>
	87-A40-291-080	--	DIODE,1N4148(CPT)	C351	87-018-195-080	--	CAP,CER 1200P-16V
	87-A40-308-080	--	ZENER,DZ10M				
	87-A40-235-080	--	ZENER,MTZJ9.1C	C352	87-018-195-080	--	CAP,CER 1200P-16V
	87-A40-234-080	--	ZENER,MTZJ5.6A	C353	87-010-263-080	OE	CAP,E 100-10 SME
	87-A40-226-080	--	VARI-CAP,SVC251SPA<HR,HS,D>	C354	87-010-263-080	OE	CAP,E 100-10 SME
	87-002-843-080		DIODE,1SS108<10EZ>	C360	87-010-370-089	OE	CAP,E 330-6.3 SME
	87-A40-304-080	--	ZENER,DZ6.2M	C390	87-018-209-080		CAP,TCU 0.1-50 ZF<10EZ,9EZ,V,G>
	87-020-465-080	OE	DIODE,1SS133				
	87-070-136-080	OE	ZENER,MTZJ5.1B	C391	87-018-115-080		CAP,TCU 47P-50J SL<10EZ,9EZ,V,G>
				C395	87-018-209-080	--	CAP,TC U 0.1-50 ZF<HS,D,HR>
				C395	87-018-134-080		CAP,TC U 0.01-16 YN<10EZ>
				C400	87-018-134-080		CAP,TC U 0.01-16 NY<10EZ,9EZ,G>
				C401	87-010-401-080	OE	CAP,E 1-50 SME
				C402	87-010-401-080	OE	CAP,E 1-50 SME
				C403	87-018-118-080	--	CAP,TC U 82P-50 J B UP050
				C404	87-018-118-080	--	CAP,TC U 82P-50 J B UP050
				C452	87-010-385-080	--	CAP,E 220-25 SME
				C458	87-018-131-080	--	CAP,CER 1000P-50V
MAIN C.B							
	85-NF5-617-010	--	CABLE,FFC 6P-1.25<D>	C459	87-018-128-080	--	CAP,CERA-SOL SS560P
	86-NFZ-785-010		CABLE,FFC 6P-1.25<HR,10EZ>	C461	87-018-126-080	--	CAP,TC U 390P-50 K B UP050
C102	87-A10-570-090	--	CAP,E 3300-25 SME	C462	87-018-126-080	--	CAP,TC U 390P-50 K B UP050
C103	87-A10-515-090	--	CAP,E 2200-25 SME	C505	87-010-401-080	OE	CAP,E 1-50 SME
C105	87-018-127-080	--	CAP,CER 470P-50V	C506	87-010-401-080	OE	CAP,E 1-50 SME
	87-010-260-080	OE	CAP,E 47-25 SME				
C106	87-010-101-080	OE	CAP,E 220-16 SME	C510	87-010-405-080	OE	CAP,E 10-50 SME
C107	87-010-381-080	OE	CAP,E 330-16 SME	C511	87-010-260-040	OE	CAP,E 47-25 SME
C108	87-010-384-080	OE	CAP,E 100-25 SME	C512	87-010-260-040	OE	CAP,E 47-25 SME
C109	87-010-384-080	OE	CAP,E 100-25 SME	C513	87-010-221-080	--	CAP,E 470-10 SME
C110	87-010-384-080	OE	CAP,E 100-25 SME	C515	87-015-951-080	--	CAP,E 1-50 M LL
	87-010-247-080	OE	CAP,E 100-50 SME				
C111	87-010-263-080	OE	CAP,E 100-10 SME	C516	87-015-951-080	--	CAP,E 1-50 M LL
C112	87-010-403-080	OE	CAP,E 3.3-50 SME	C517	87-018-134-080		CAP,TC U 0.01-16 YN<10EZ>
C113	87-010-374-080	--	CAP,E 47-10 SME	C518	87-018-134-080	OE	CAP,TC U 0.01-16 YN
C114				C551	87-018-115-080		CAP,TC U 47P-50 J B UP050<10EZ>
				C552	87-018-115-080		CAP,TC U 47P-50 J SL UP050<10EZ>

REF. NO.	PART NO.	KANRI NO.	DESCRIPTION	REF. NO.	PART NO.	KANRI NO.	DESCRIPTION
C553	87-018-115-080		CAP,TCU 47P-50 J SL UP050<10EZ>	C867	87-018-134-080		CAP,TC U 0.01-16 N YU<10EZ>
C700	87-018-198-010		CAP,TC U 2700P-16<10EZ,9EZ,G>	C868	87-018-111-080		CAP,TCU 27P-50 J SL<10EZ>
C701	87-010-404-080	0E	CAP,E 4.7-50 SME	C869	87-018-111-080		CAP,TCU 27P-50 J SL<10EZ>
C704	87-018-131-080		CAP,CER 1000P-50V<10EZ,9EZ,V,G>	C903	87-010-401-080	0E	CAP,E 1-50 SME<HR,D,HR,HS>
C711	87-010-260-040	0E	CAP,E 47-25 SME	C941	87-018-107-080		CAP,TC U 18P-50 J SL UP050<HR>
C712	87-010-112-040	0E	CAP,E 100-16 SME	C942	87-018-141-080		CAP,TCU 3.3P-50CH<10EZ,9EZ,V,G>
C722	87-018-149-080	--	CAP,TC U 15P-50 J CH UP050	C942	87-018-104-080	--	CAP,TC U 10P-50 J SL<D,HS>
C728	87-010-248-040	0E	CAP,E 220-10 SME	C943	87-018-134-080		CAP,TC U 0.01-16 N Y<HR>
C730	87-018-134-080		CAP,TC U 0.01-16 YN<10EZ>	C944	87-014-051-010		CAP PP 560P-100 J<HR>
C733	87-018-148-080	--	CAP,TC U 12P-50 J CH UP050	C945	87-018-134-080		CAP,TC U 0.01-16 N Y<HR>
C741	87-010-401-080	0E	CAP,E 1-50 SME<D,10EZ,9EZ,V,G>	C946	87-010-401-080		CAP,E 1-50 SME<10EZ,9EZ,V,G>
C741	87-010-546-080		CAP,E 0.33-50 SME<HR,HS>	C949	87-014-049-080		CAP PP 470P-100 J<10EZ,9EZ,V,G>
C742	87-010-401-080	0E	CAP,E 1-50 SME<D,10EZ,9EZ,V,G>	C950	87-014-073-010		CAP PP 4700P-100 J<HR>
C742	87-010-546-080		CAP,E 0.33-50 SME<HR,HS>	C952	87-018-134-080		CAP,TCU 0.01-16NY<10EZ,9EZ,V,G>
C743	87-010-404-080	0E	CAP,E 4.7-50 SME<D>	C953	87-018-134-080		CAP,TC U 0.01-16 N Y<HR>
C744	87-010-260-080	0E	CAP,E 47-25 SME<D>	C954	87-010-400-080		CAP,E 0.47-50 SME<HR>
C745	87-010-401-080	0E	CAP,E 1-50 SME<D>	C955	87-018-134-080		CAP,TCU 0.01-16NY<10EZ,9EZ,V,G>
C746	87-010-401-080	0E	CAP,E 1-50 SME<D>	C956	87-010-263-080		CAP,E 100-10 SME<HR>
C747	87-018-134-080	0E	CAP,TC U 0.01-16 N YU<D>	C957	87-018-104-080		CAP,TCU 10P-50 J SL<10EZ>
C748	87-018-205-080	--	CAP,CERA-SOL SS 0.022<D>	C958	87-018-134-080		CAP,TCU 0.01-16NY<10EZ,9EZ,V,G>
C749	87-010-248-040	0E	CAP,E 220-10 SME<D>	C960	87-018-209-080		CAP,TC U 0.1-50ZF<10EZ,9EZ,V,G>
C752	87-018-107-080	--	CAP,TC U 18P-50 SL UP050<D>	C980	87-018-134-080		CAP,TC U 0.01-16 NY<10EZ,9EZ,G>
C753	87-010-402-080	0E	CAP,E 2.2-50 SME<D>	C999	87-018-209-080		CAP,TC U 0.1-50 ZF UP050<HR>
C754	87-018-147-080	--	CAP,TC U 10P-50 J CH UP050<D>	CF801	87-008-423-080		FLTR,SFE10.7MS3<10EZ,9EZ,G>
C755	87-010-402-080	0E	CAP,E 2.2-50 SME<D>	CF801	87-008-261-010	1A	FLTR,CFSFE10.7MA5<D,HR,HS,V>
C760	87-010-401-080	0E	CAP,E 1-50 SME<D>	CF802	82-785-747-080		CF,MS2 6HY,R<10EZ,9EZ,G>
C761	87-010-401-080	0E	CAP,E 1-50 SME<D>	CF802	87-008-261-010		FLTR,CFSFE10.7MA5<V>
C771	87-010-405-040	0E	CAP,E 10-50 SME	CON351	85-CF5-660-010	--	CONN ASSY,8P-RPB
C773	87-018-208-080	--	CAP,0.047-50F	FFE801	A8-6ZA-195-030		6ZA-1 YFEENM<10EZ,9EZ,G>
C774	87-010-263-080	0E	CAP,E 100-10 SME	FFE801	A8-6ZA-197-030		6ZA-1 YFEVNM<V>
C775	87-010-405-040	0E	CAP,E 10-50 SME	J201	87-A60-024-010	1B	JACK,DIA 6.3 BLK W/WS KM
C777	87-010-400-089	0E	CAP,E 0.47-50 SME	J202	87-A60-238-010	1A	TERMINAL,SP 4P (MSC)
C778	87-010-401-080	0E	CAP,E 1-50 SME	J203	87-A60-354-010	--	JACK,PIN 2P
C779	87-010-401-080	0E	CAP,E 1-50 SME	J801	87-033-235-010		TERMINAL,ANT 4P CJ-9028<HR>
C781	87-010-402-080	0E	CAP,E 2.2-50 SME<D>	J802	87-033-241-010		TERMINAL,ANT 2P<10EZ,9EZ,G>
C782	87-010-402-080	0E	CAP,E 2.2-50 SME<D>	L201	87-005-366-010		COIL,1uH K<10EZ,9EZ,V,G>
C783	87-018-208-080	--	CAP,0.047-50F<D>	L202	87-005-366-010		COIL,1uH K<10EZ,9EZ,V,G>
C784	87-018-208-080	--	CAP,0.047-50F<D>	L451	87-007-342-010	0E	COIL,OSC 85KHZ
C791	87-010-401-080	0E	CAP,E 1-50 SME	L741	87-A50-015-010	--	COIL,FM DET (TOK)
C792	87-018-196-080	--	CAP,CER 1500P-16V<D,HR,HS,V>	L742	87-A90-245-010		FLTR,CFAZH-450 (TOK)<EXP HR,D>
C794	87-010-260-080	0E	CAP,E 47-25 SME	L742	87-A90-052-010		FLTR,CFMT-450A (TOK)<HR>
C795	87-018-208-080		CAP,0.047-50F<10EZ,9EZ,V,G>	L742	87-A90-053-010	--	FLTR,PCFMT-060 (TOK)<D>
C796	87-010-403-080	0E	CAP,E 3.3-50 SME	L801	87-A50-110-010		COIL,FM BPF EX<HR,HS>
C799	87-010-405-040	0E	CAP,E 10-50 SME	L801	87-A50-152-010	--	COIL,FM BPF D<D>
C801	87-018-102-089	--	CAP,TC U 6.8P-50K SL<D,HR,HS>	L802	87-006-244-010	--	COIL,RF FM 3-1/2T L4<D,HR,HS>
C806	87-018-101-089	--	CAP,TC U 5.6P-50K SL<D,HR,HS>	L803	87-006-246-010		COIL,RF FM 3-1/2T L4<HR,HS>
C807	87-018-102-089	--	CAP,TC U 6.8P-50K SL<D,HR,HS>	L803	87-A50-154-010	--	COIL,RF FM 3-3/4T D<D>
C808	87-018-098-080	--	CAP,TC U 3.3P-50K SL<D,HR,HS>	L804	86-NFZ-694-010	--	COIL,2.2uH K CECS<D,HR,HS>
C809	87-018-119-080	--	CAP,TC U 100P-50K B<D,HR,HS>	L805	87-A50-111-110		COIL,FM OSC EX<HR,HS>
C811	87-018-107-080		CAP,TC U 18P-50 J SL<HR,HS>	L805	87-A50-153-010	--	COIL,FM OSC D<D>
C811	87-018-103-080	--	CAP,CER 8.2P-50V<D>	L806	86-ZA1-604-110	--	IFT,FM IFT7-6.2<D,HR,HS>
C815	87-018-134-080	0E	CAP,TCU 0.01-16NY<HR,D,10EZ,HS>	L807	86-NFZ-694-010	--	COIL,2.2uH K CECS<D,HR,HS>
C820	87-010-260-080		CAP,E 47-25 SME<10EZ,9EZ,V,G>	L832	87-005-847-080		COIL,2.2uH K CECS<10EZ,9EZ,V,G>
C821	87-018-105-080	--	CAP,TC U 12P-50 J SL<D,HR,HS>	L850	87-005-847-080		COIL,2.2uH K CECS<10EZ>
C821	87-018-134-080		CAP,TCU 0.01-16NY<10EZ,9EZ,V,G>	L901	86-NF4-666-010		COIL,AM PACK 3 (TOK)<HR>
C822	87-018-111-080	--	CAP,CERA-SOL 27P<D,HR,HS>	L901	86-NFZ-634-110	--	COIL,AM PACK 4 (TOK)<D,HS>
C823	87-018-111-080	--	CAP,CERA-SOL 27P<D,HR,HS>	L941	87-A50-020-010		COIL,ANT LW<10EZ,9EZ,V,G>
C823	87-018-134-080		CAP,TCU 0.01-16NY<10EZ,9EZ,V,G>	L941	87-A50-022-010		COIL,ANT SW<HR>
C824	87-018-109-080		CAP,TCU 22P-50J SL UP050<HR,HS>	L942	87-A50-019-010		COIL,OSC LW<10EZ,9EZ,V,G>
C824	87-018-100-080	--	CAP,CER 4.7P-50V<D>	L942	87-A50-021-010		COIL,OSC SW<HR>
C825	87-018-209-080		CAP,TCU 0.1-50 ZF<10EZ,9EZ,V,G>	L943	87-005-372-080		COIL,1mH K LAL03<HR>
C849	87-018-134-080		CAP,TCU 0.01-16NY<10EZ,9EZ,V,G>	L944	87-003-131-080		COIL,10mH J EL0607<HR>
C851	87-018-131-080		CAP,TCU 1000P-50B<10EZ,9EZ,V,G>	L981	86-NF4-665-010		COIL,AM PACK1<10EZ,9EZ,V,G>
C852	87-018-131-080		CAP,TCU 1000P-50K<10EZ,9EZ,V,G>	PR401	87-A90-246-080		PROTECTOR 0.25A 60V<EXP D>
C861	87-018-131-080		CAP,TCU 1000P-50K<10EZ>	PR401	87-035-515-080	--	PROTECTOR 0.25A 125V<D>
C862	87-010-132-080		CAP,TCU 2200P-16N X UP050<10EZ>	R245	87-022-050-080	--	RES,M/F 0.22-1W J
C863	87-018-127-080		CAP,TCU 470P-50 K B UP050<10EZ>	R246	87-022-050-080	--	RES,M/F 0.22-1W J
C864	87-010-405-040		CAP,E 10-50 SME<10EZ>	SFR451	87-A90-557-080	--	SFR,33K H HOKU
C865	87-018-209-080		CAP,TC U 0.1-50 ZF UP050<10EZ>	SFR452	87-A90-557-080	--	SFR,33K H HOKU
C866	87-010-405-040		CAP,E 10-50 SME<10EZ>	SFR722	87-A90-500-080	--	SFR,10K H NVZ6TLTA

REF. NO.	PART NO.	KANRI NO.	DESCRIPTION	REF. NO.	PART NO.	KANRI NO.	DESCRIPTION
TC941	87-011-254-080		TRIMMER,CER 20P<HR>	S306	87-A90-095-080	0E SW,TACT	EVQ11G04M
TC942	87-011-253-080		TRIMMER,CER 30P<EXP D,HS>	S307	87-A90-095-080	0E SW,TACT	EVQ11G04M
W101	86-NFZ-705-010	--	F-CABLE,5P	S308	87-A90-095-080	0E SW,TACT	EVQ11G04M
X702	87-030-283-010	--	VIB,CER 3.5898 MHZ CSA<D>	S309	87-A90-095-080	0E SW,TACT	EVQ11G04M
X703	87-A70-044-010	--	VIB,CER CMU2-456A15	S310	87-A90-095-080	0E SW,TACT	EVQ11G04M
X721	86-NFZ-651-010	--	VIB,XTAL 4.500MHZ CSA-309	S311	87-A90-095-080	0E SW,TACT	EVQ11G04M
X850	87-A90-091-010		XTAL 4.332MHZ CSA-309<10EZ>	S312	87-A90-095-080	0E SW,TACT	EVQ11G04M
				S313	87-A90-095-080	0E SW,TACT	EVQ11G04M
				S314	87-A90-095-080	0E SW,TACT	EVQ11G04M
				S315	87-A90-095-080	0E SW,TACT	EVQ11G04M
FRONT C.B							
	86-NFZ-787-010		FF-CABLE,13P 1.25<HR,10EZ>	S316	87-A90-095-080	0E SW,TACT	EVQ11G04M
	86-NFZ-637-010	--	FF-CABLE,13P CD<D>	S317	87-A90-095-080	0E SW,TACT	EVQ11G04M
C201	87-010-404-040	0E	CAP,E 4.7-50 SME	S318	87-A90-095-080	0E SW,TACT	EVQ11G04M
C202	87-010-404-040	0E	CAP,E 4.7-50 SME	S319	87-A90-095-080	0E SW,TACT	EVQ11G04M
C203	87-010-405-040	0E	CAP,E 10-50 M SME	S320	87-A90-095-080	SW,TACT	EVQ11G04M<10EZ>
C204	87-010-408-040	0E	CAP,E 47-50 M SME	S321	87-A90-095-080	SW,TACT	EVQ11G04M<10EZ>
C205	87-018-208-080	--	CAP,0.047-50 F	S322	87-A90-095-080	SW,TACT	EVQ11G04M<10EZ>
C206	87-018-208-080	--	CAP,0.047-50 F	SFR201	87-A90-556-080	--	SFR,2.2K H HOKU
C207	87-010-401-040	0E	CAP,E 1-50 M SME	SW201	87-A90-392-010	--	SW,RTRY EC16B24304-20 NON
C208	87-010-263-040	0E	CAP,E 100-10 M SME	VR401	86-NFA-607-010	VR,RTRY	10K15X11V XV0121<HR,HS>
C210	87-018-208-080	--	CAP,0.047-50 F				
C211	87-010-248-040	0E	CAP,E 220-10 M SME	AC1 C.B			
C212	87-018-208-080	--	CAP,0.047-50 F	△	CL1	87-A90-505-080	-- FUSE CLAMP,TP00351-5
C213	87-010-401-040	0E	CAP,E 1-50 M SME	△	CL2	87-A90-505-080	-- FUSE CLAMP,TP00351-5
C215	87-018-150-080	--	CAP,TC U 18P-50 J CH UP050	△	F101	87-035-219-010	FUSE,500MA 250V T 21<HR>
C216	87-018-147-080	--	CAP,TC U 10P-50 J CH UP050	△	F101	87-035-217-010	FUSE,315MA 250V T<10EZ,9EZ,V,G>
C217	87-018-122-080	--	CAP,TC U 180P-50 B	△	F101	87-035-411-010	-- FUSE,1A 250V U L<D>
C220	87-018-127-080	--	CAP,TC U 470P-50 K B UP050	△	F101	87-035-218-010	FUSE,400MA 250V T<HS>
C223	87-010-384-040	0E	CAP,E 100-25 SME	△	PT101	87-NF9-604-010	PT,7NF9-HE<HR>
C226	87-018-134-080	0E	CAP,TC U 0.01-16 N Y UP050	△	PT101	87-NF9-602-010	PT,7NF9-EKZ<10EZ,9EZ,V,G>
C291	87-018-134-080	0E	CAP,TC U 0.01-16 N Y UP050	△	PT101	87-MA8-644-010	-- PT,7MA8-D<D>
C292	87-018-134-080	0E	CAP,TC U 0.01-16 N Y UP050	△	PT101	87-NF9-604-010	PT,7NF9-HE<HR>
C293	87-018-134-080	0E	CAP,TC U 0.01-16NY<9EZ,V,G>	△	PT101	87-NF9-608-010	PT,7NF9-HS<HS>
C296	87-018-134-080	0E	CAP,TC U 0.01-16NY<9EZ,V,G>	△	SW101	87-A90-234-010	SW,SL 1-2-2 SW2201<HR>
C400	87-010-405-040		CAP,E 10-50 M SME<HR,HS>	△	T1	87-A60-317-010	0E TERMINAL,1P MSC
C404	87-010-544-040		CAP,E 0.1-50 M SME<HR,HS>	△	T2	87-A60-317-010	0E TERMINAL,1P MSC
C405	87-010-401-040		CAP,E 1-50 M SME<HR,HS>				
C407	87-010-545-040		CAP,E 0.22-50 M SME<HR,HS>				
CON201	86-NFZ-635-010	--	CONN ASSY,9P MECHA	AC2 C.B			
FB201	87-008-372-080	0E	FLTR,EMIBOL RN1<HR,HS,D>				
FL301	82-NF7-631-010	--	FL 7BT-185GK<EXP 10EZ>	C100	87-018-134-080		CAP,TC U 0.01-16 NY<10EZ,9EZ,G>
FL301	86-NF6-661-010		FL 10BT-183GK<10EZ>				
J401	87-A60-235-010		JACK,3.5MO-JT<HR,HS>				
L201	86-NFZ-693-010	--	COIL,CLK 4.19MHZ				
R250	87-029-129-090	--	RES,FUSE 3.3-1/4W J				
S301	87-A90-095-080	0E	SW,TACT EVQ11G04M				
S302	87-A90-095-080	0E	SW,TACT EVQ11G04M				
S303	87-A90-095-080	0E	SW,TACT EVQ11G04M				
S304	87-A90-095-080	0E	SW,TACT EVQ11G04M				
S305	87-A90-095-080	0E	SW,TACT EVQ11G04M				

○チップ抵抗部品コード/CHIP RESISTOR PART CODE

チップ抵抗部品コードの成り立ち
Chip Resistor Part Coding

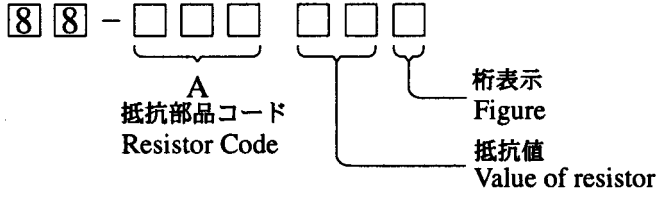

チップ抵抗
Chip resistor

容量 Wattage	種類 Type	許容誤差 Tolerance	記号 Symbol	寸法/Dimensions (mm)			抵抗コード : A Resistor Code : A	
				外形/Form	L	W		t
1/16W	1608	± 5%	CJ		1.6	0.8	0.45	108
1/10W	2125	± 5%	CJ		2	1.25	0.45	118
1/8W	3216	± 5%	CJ		3.2	1.6	0.55	128

TRANSISTOR ILLUSTRATION



E C B

2SC1923
2SC535
KTC3198
KTA1266



E C B

2SD655E
CSD1489B
2SC2001



E C B

DTA114YS DTC114YS
DTA144WS DTA144ES
DTC143XS 2SC2785
DTC144ES 2SA933
DTA143ES 2SC1740
DTA114ES



B C E

2SB1370
2SD2061



G S D

2SK439

IC BLOCK DIAGRAM - 1

IC, BU4052BC

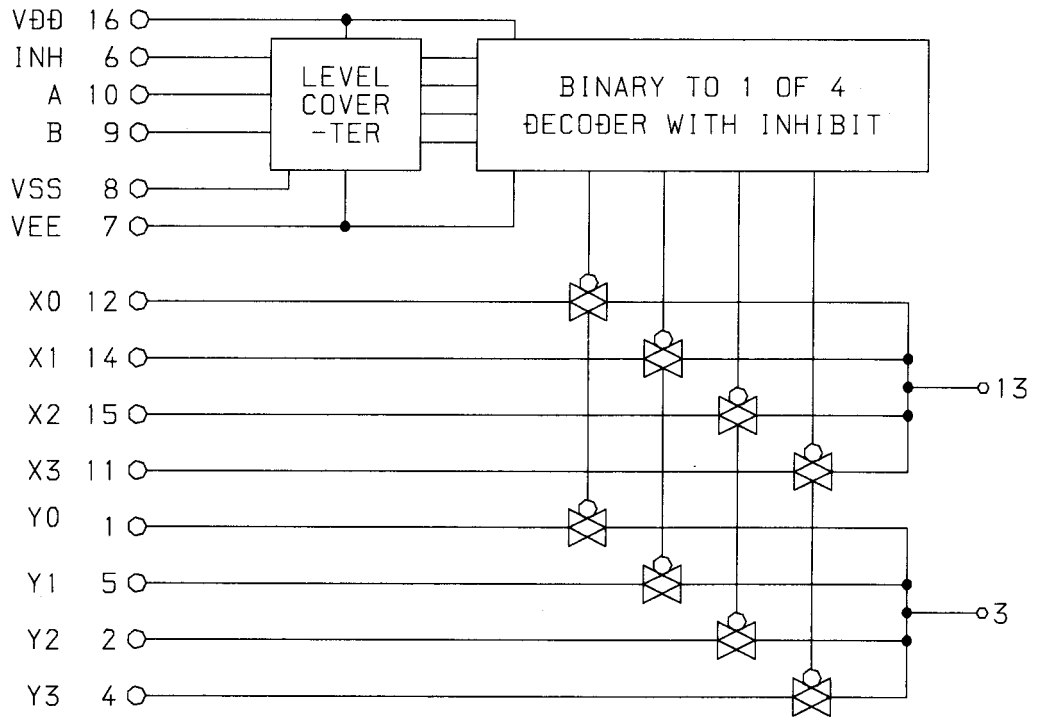

TRUTH TABLE

INHIBIT	A	B	ON SWITCH
L	L	L	X0 Y0
L	H	L	X1 Y1
L	L	H	X2 Y2
L	H	H	X3 Y3
H	X	X	NONE

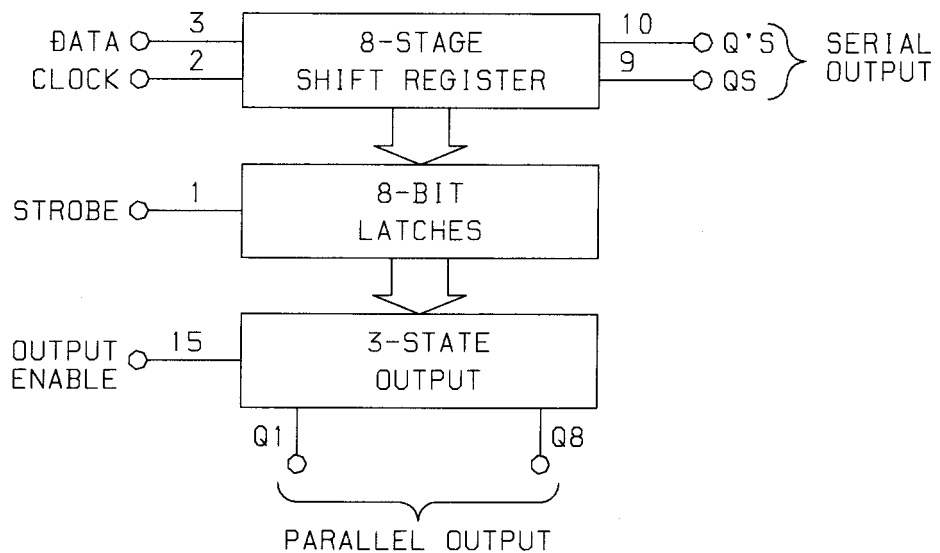

BLOCK DIAGRAM - 1 (MAIN / FRONT : EXCEPT 10EZ)

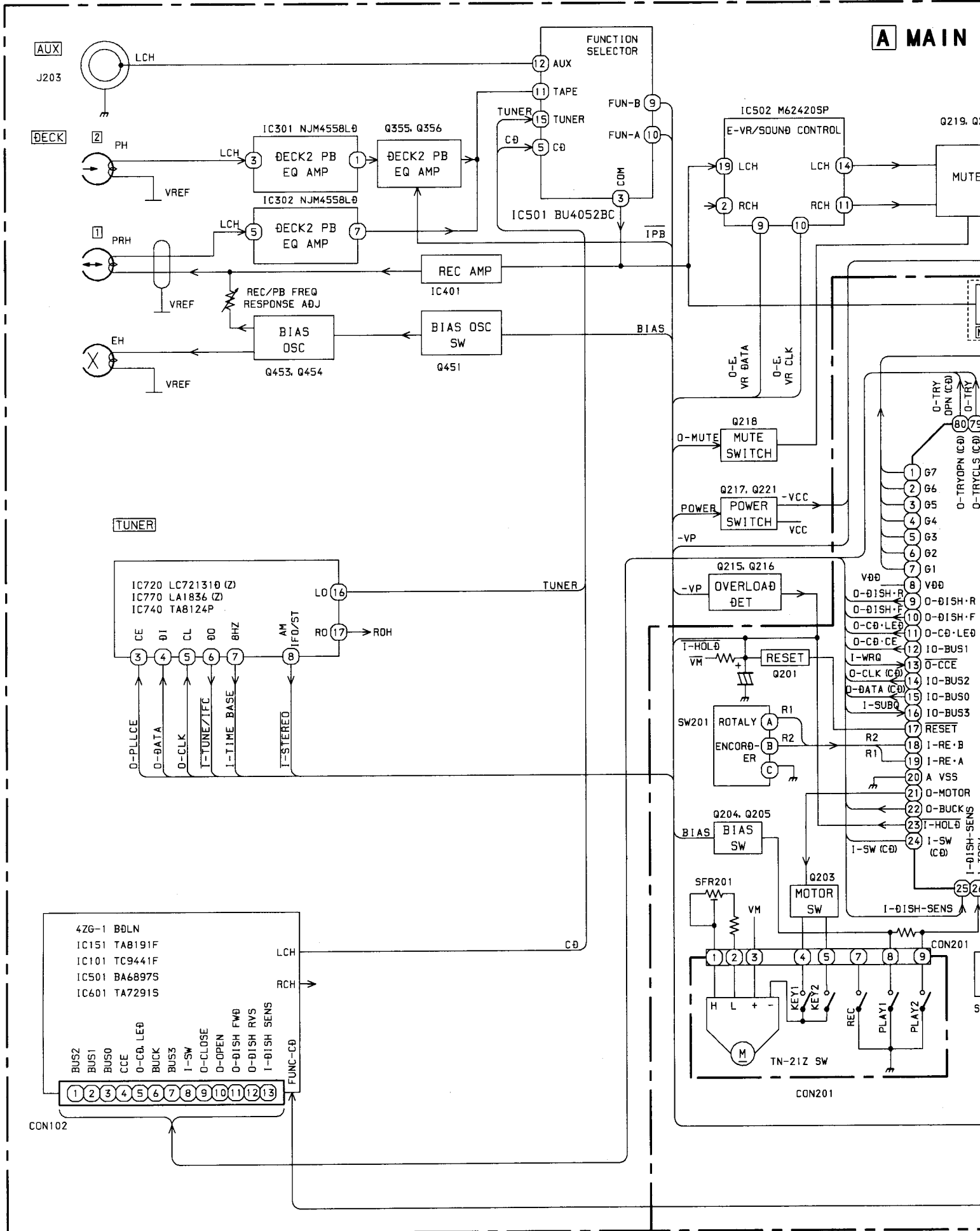

A MAIN C.I

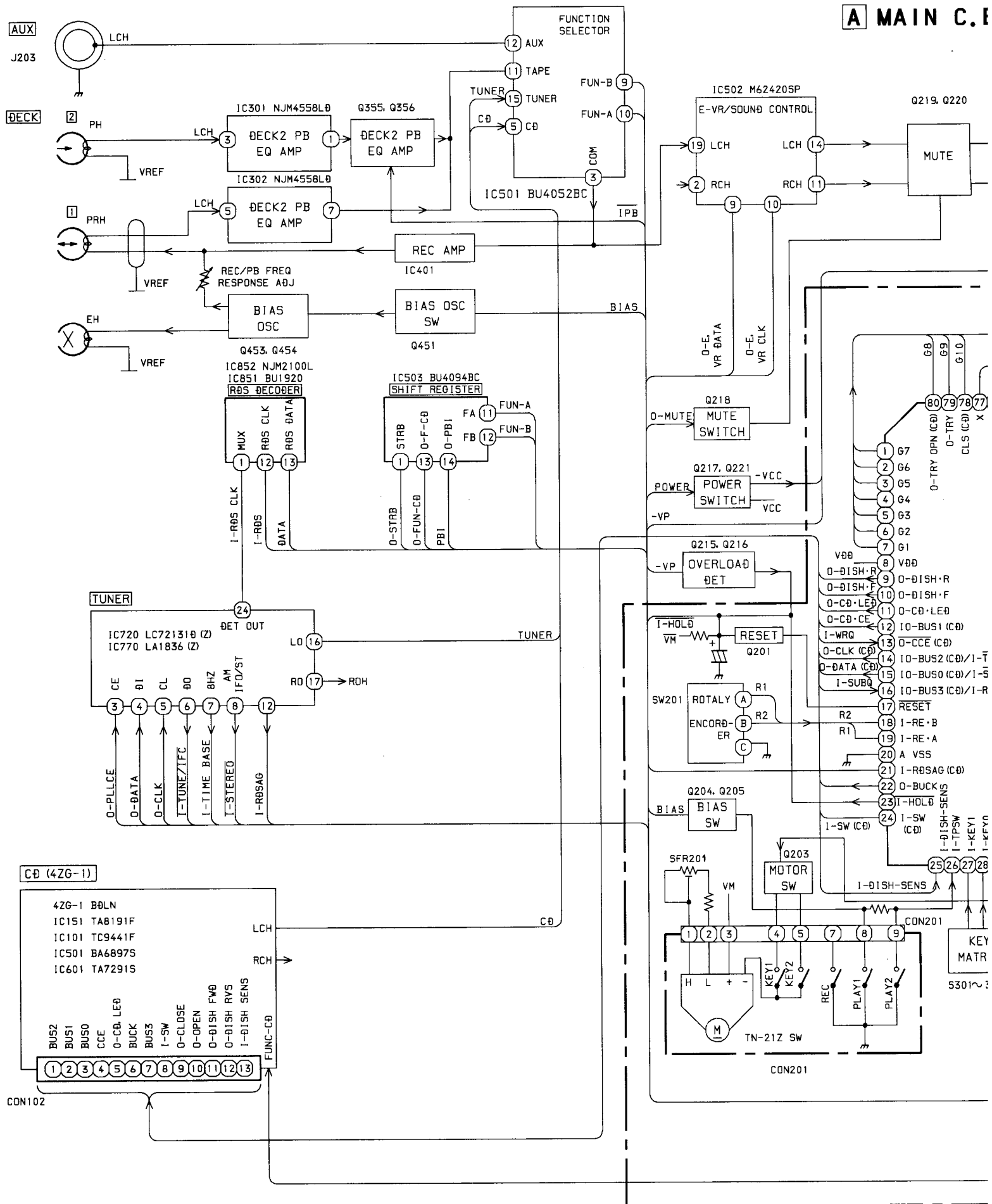

A MAIN C.B

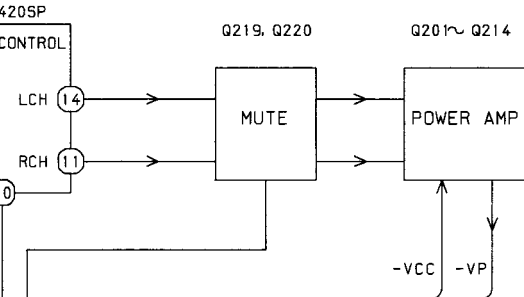

B FRONT C.B

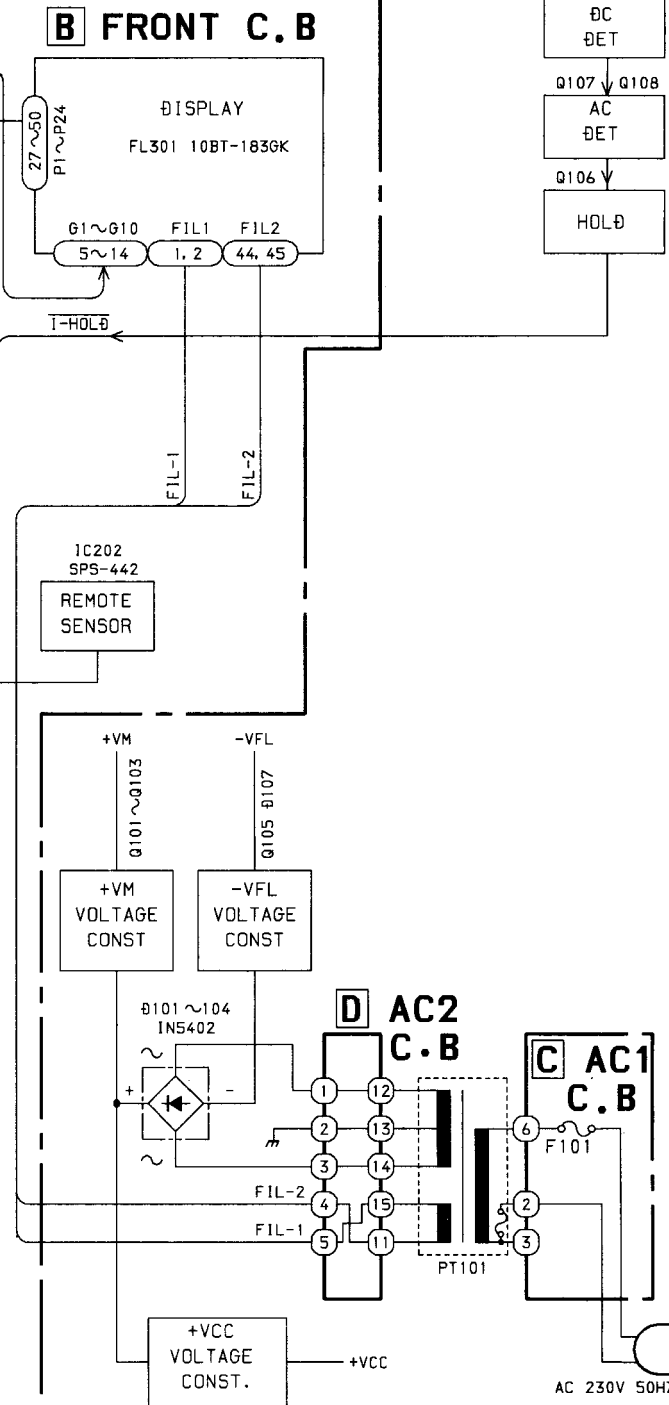
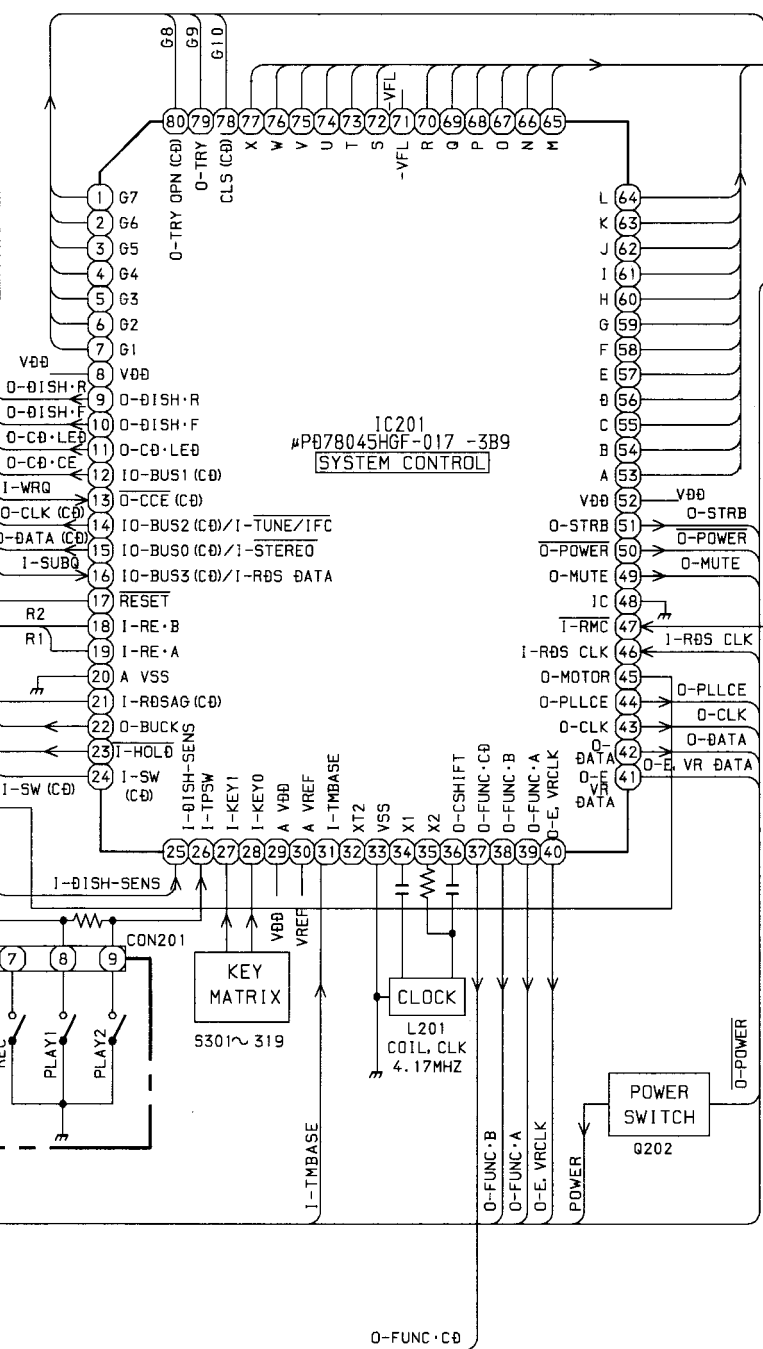

WIRING - 1 (MAIN : D)

1 2 3 4 5 6 7 8

A

A MAIN C.B

B

C

D

E

F

G

H

I

J

FM ANTENNA

J950
AM LOOP

J503
VIDEO/
AUX

FROM 3CD C.B
TO CON602

WH102
TO AC C.B
WHT

J202
SPEAKERS
SPEAKER
IMP: 6Ω

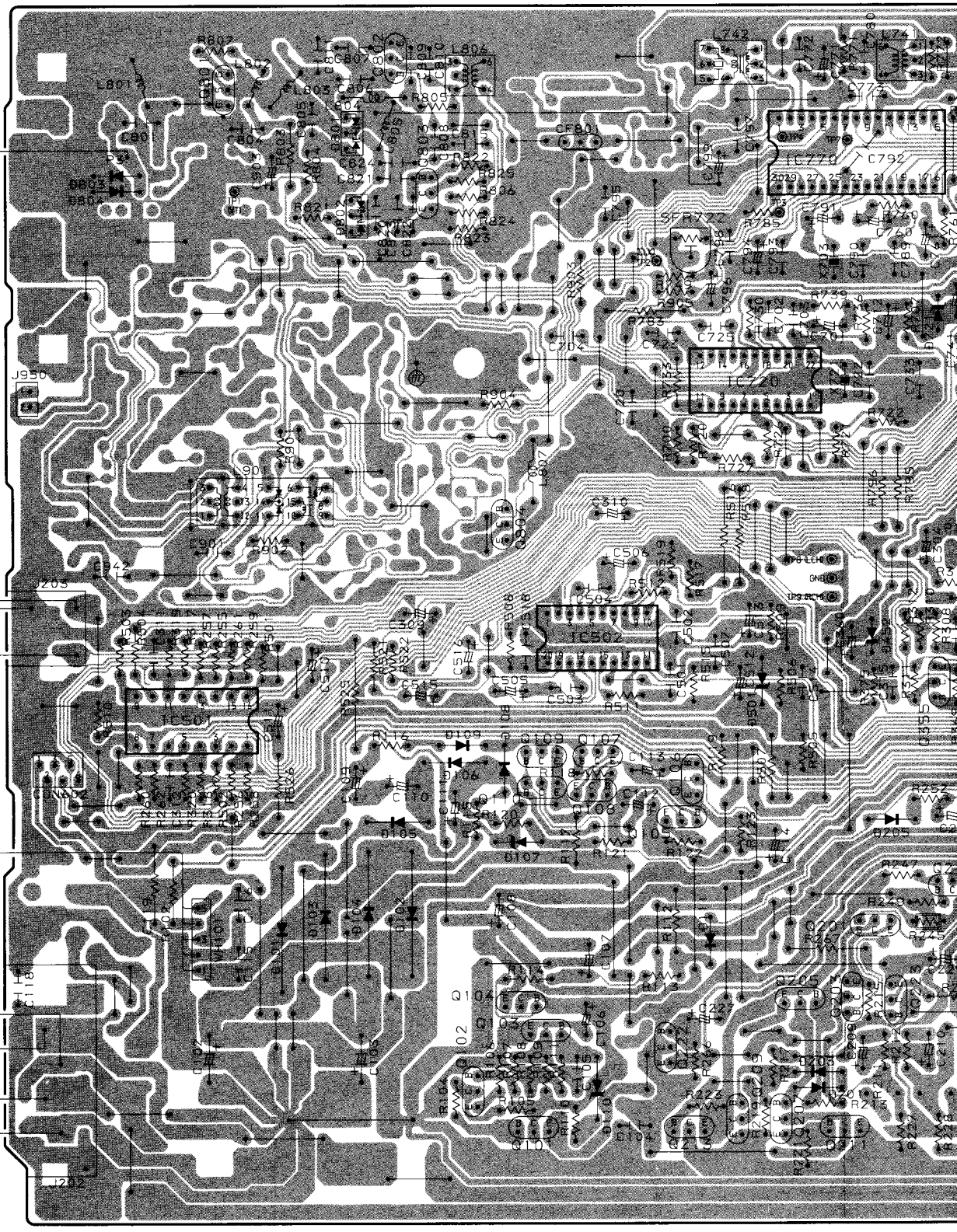

TO
FROM D

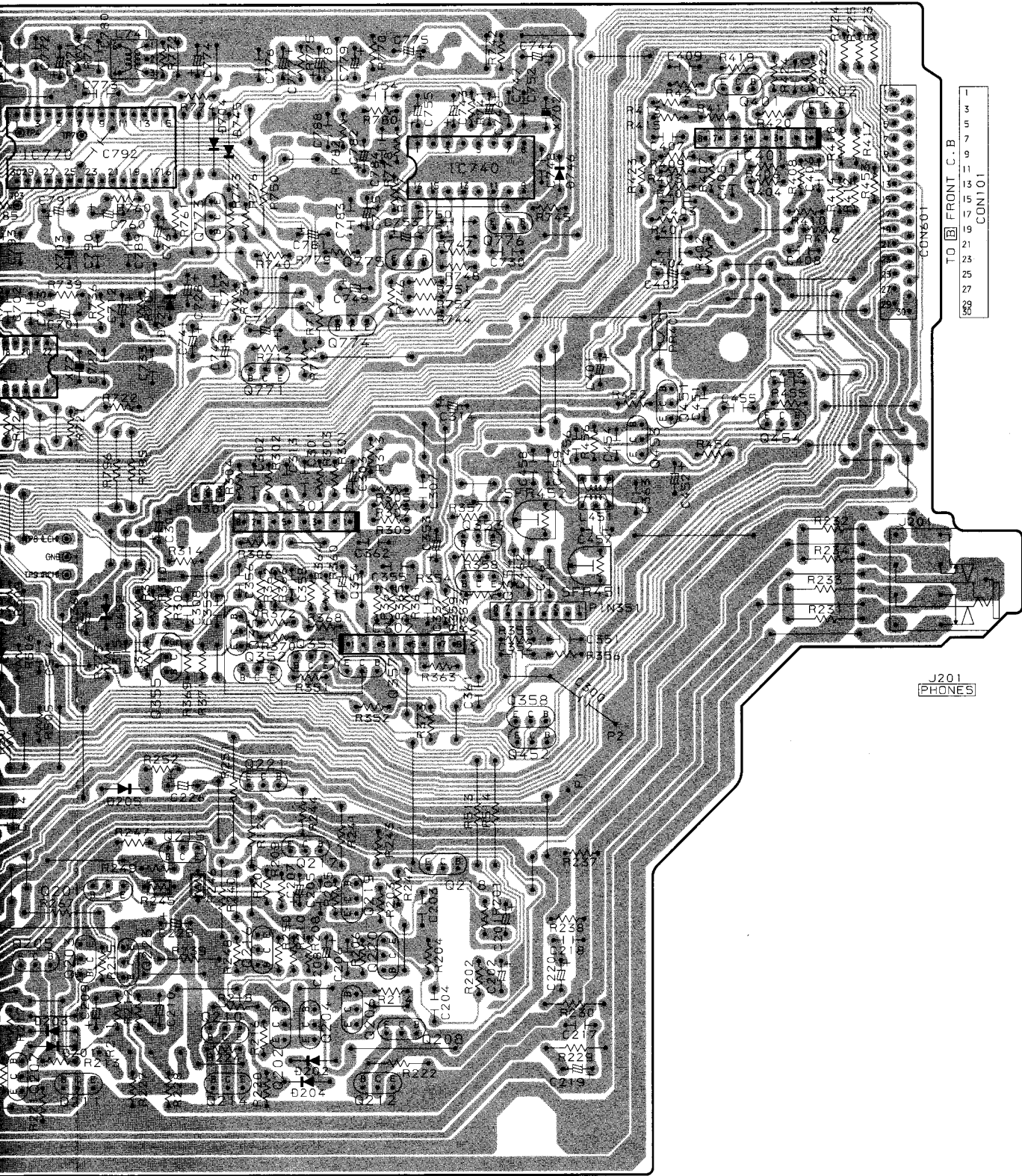

- 1
 - 3
 - 5
 - 7
 - 9
 - 11
 - 13
 - 15
 - 17
 - 19
 - 21
 - 23
 - 25
 - 27
 - 29
 - 30
- TO FRONT C.B.
CON101

J201
PHONES

↑
TO PIN301
1 2 3
FROM DECK MECHA

↑
TO PIN351
8 7 5 3 1
FROM DECK MECHA

SCHEMATIC DIAGRAM - 1 (MAIN : D)

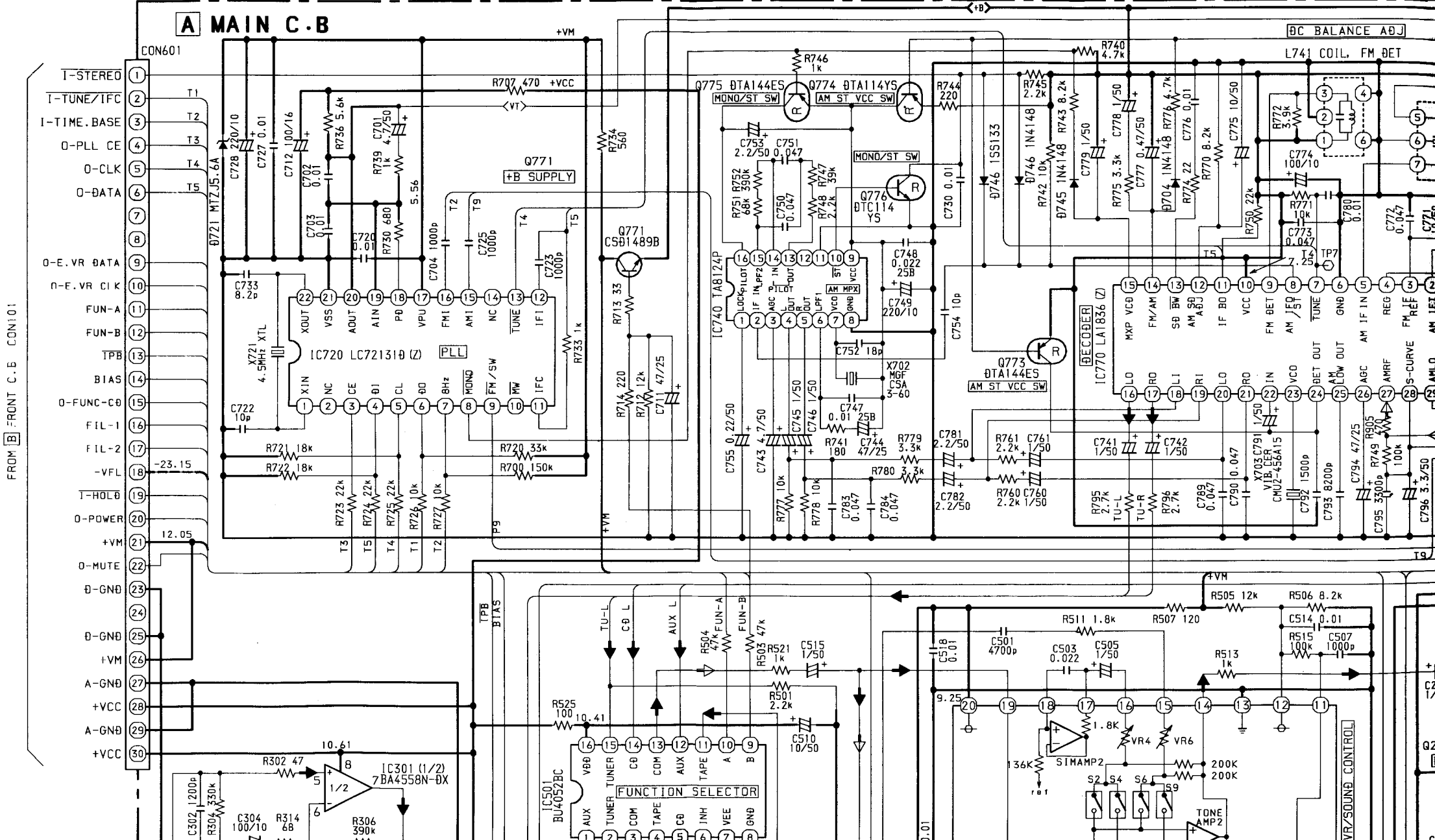

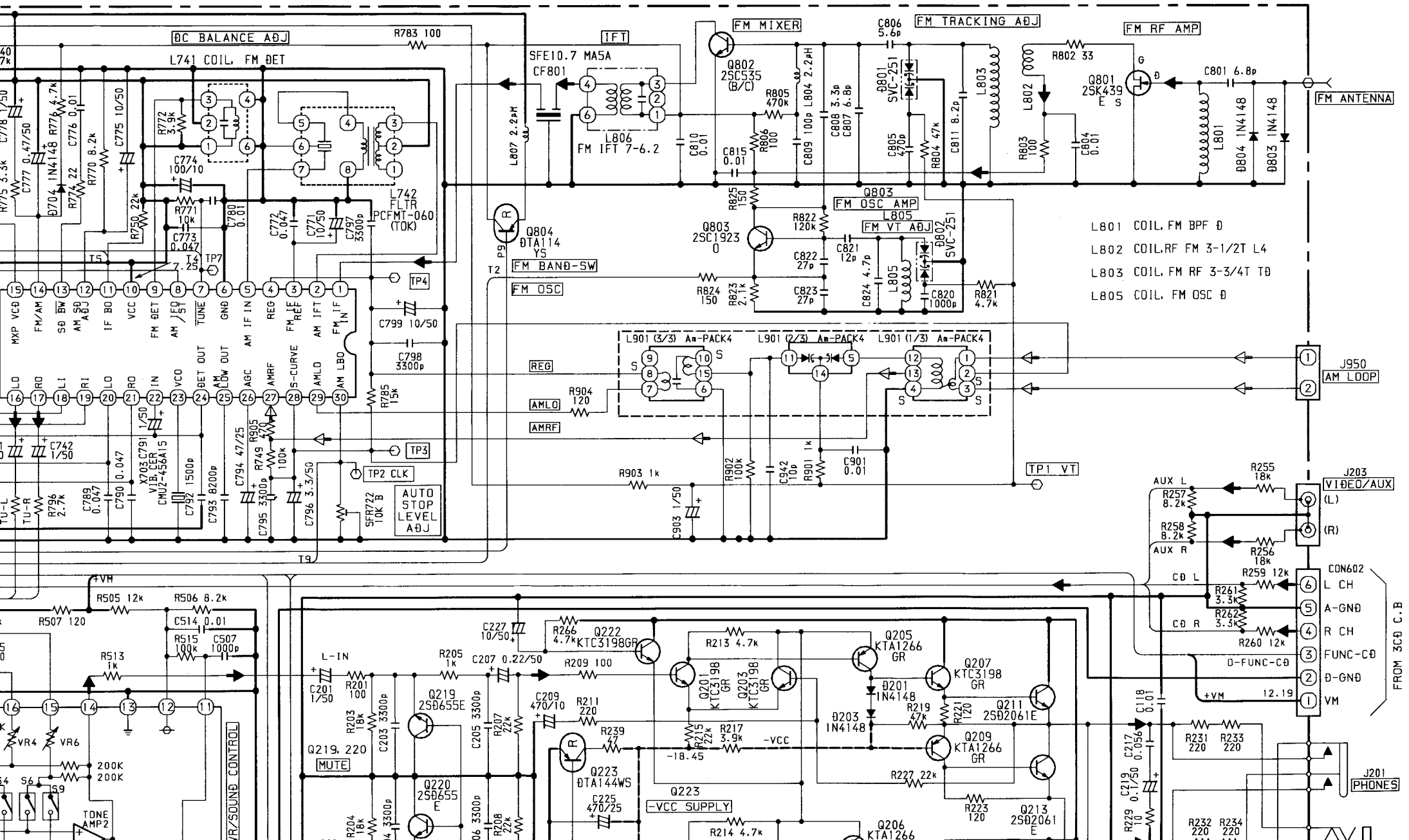

- L801 COIL, FM BPF Ø
- L802 COIL, RF FM 3-1/2T L4
- L803 COIL, FM RF 3-3/4T TØ
- L805 COIL, FM OSC Ø

FROM 3Ø C. B

FROM FRONT C.B.

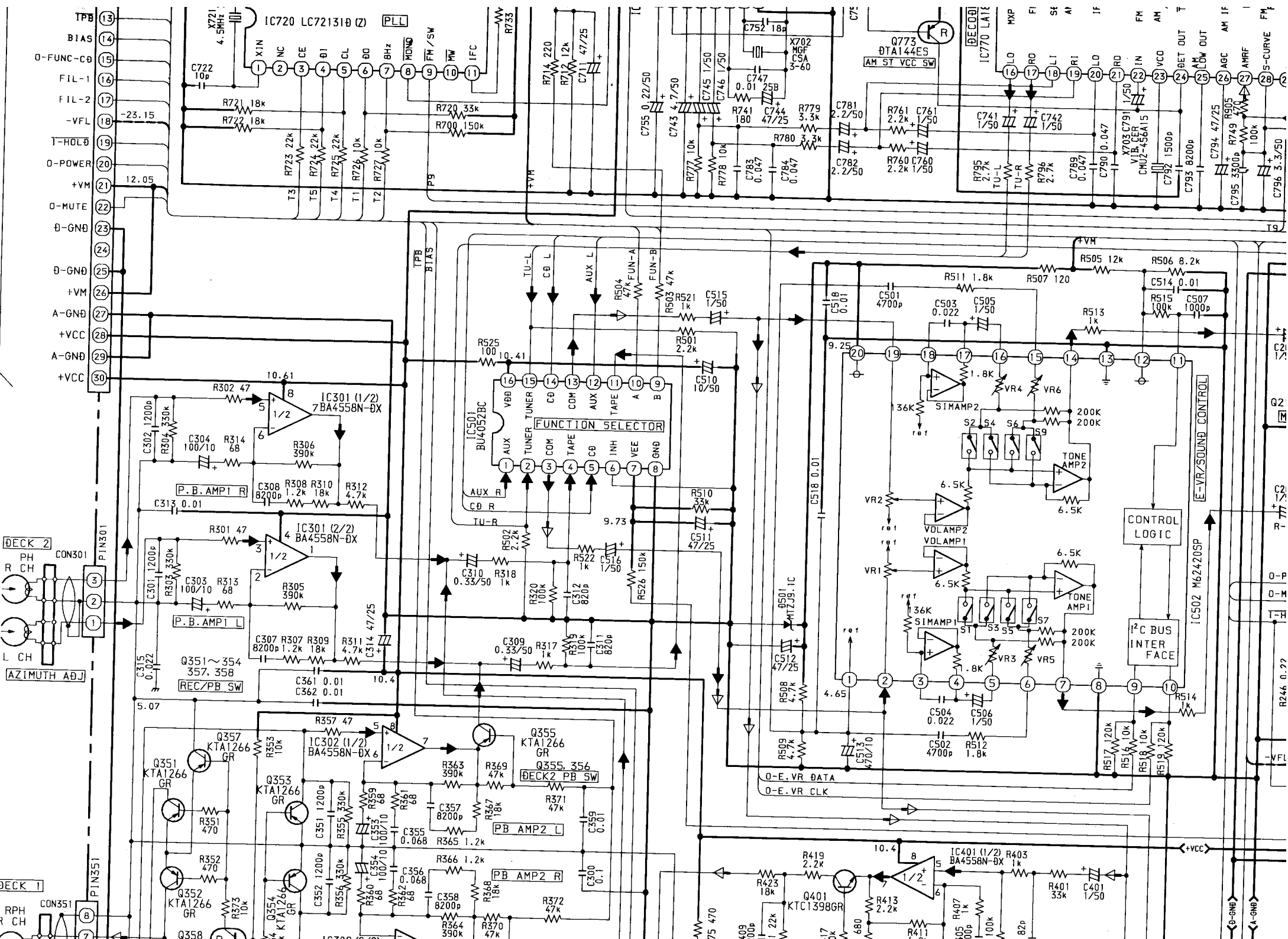

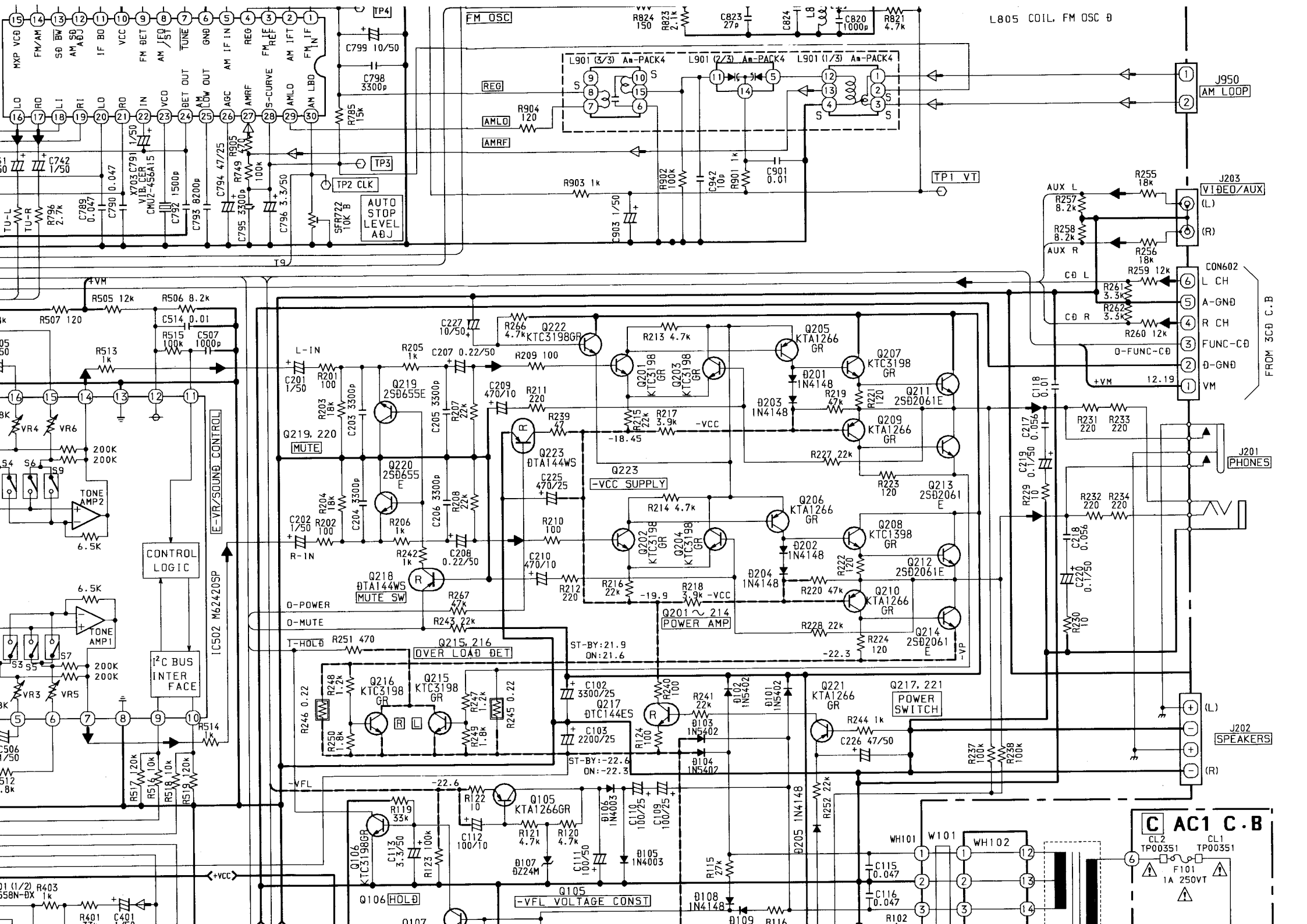

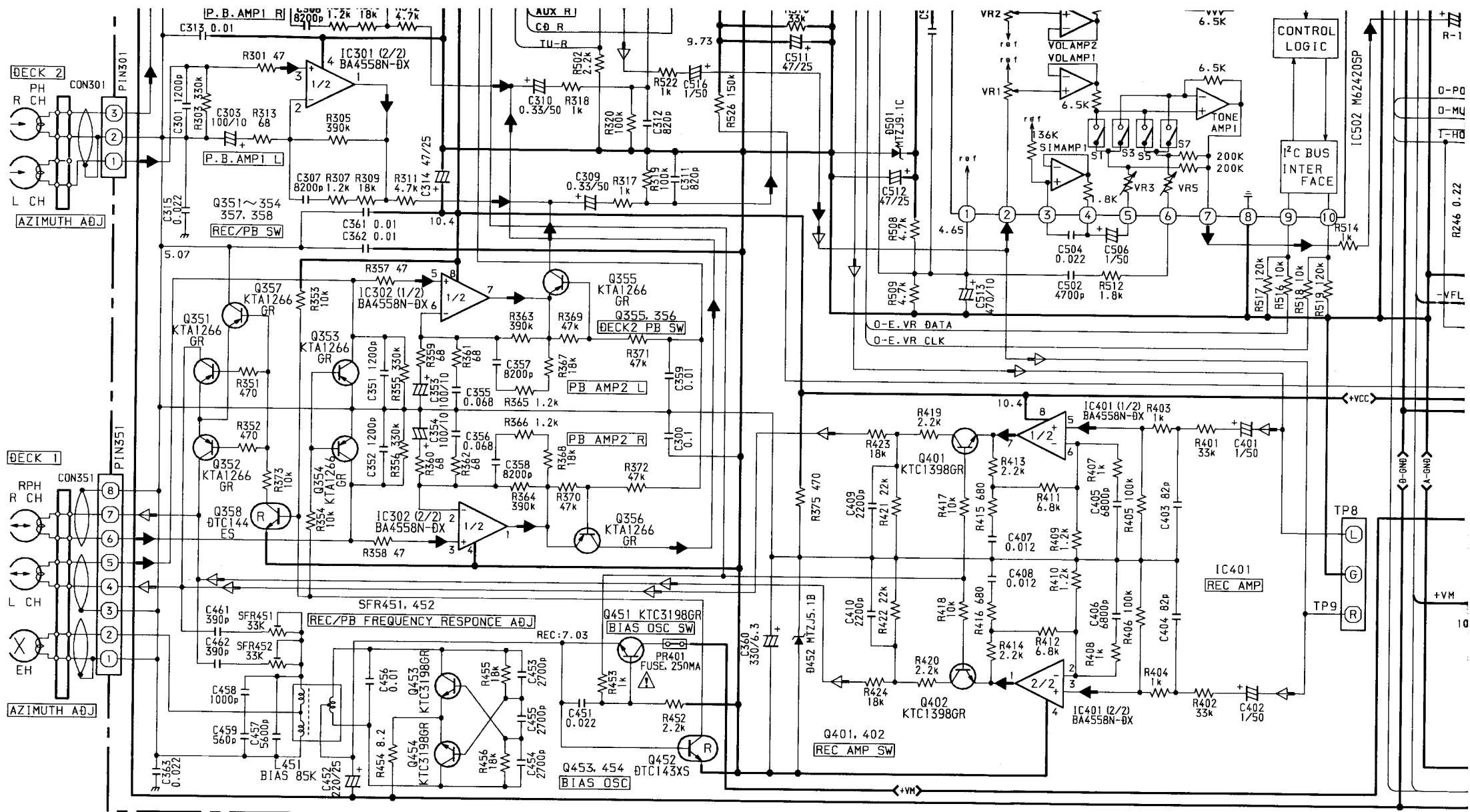

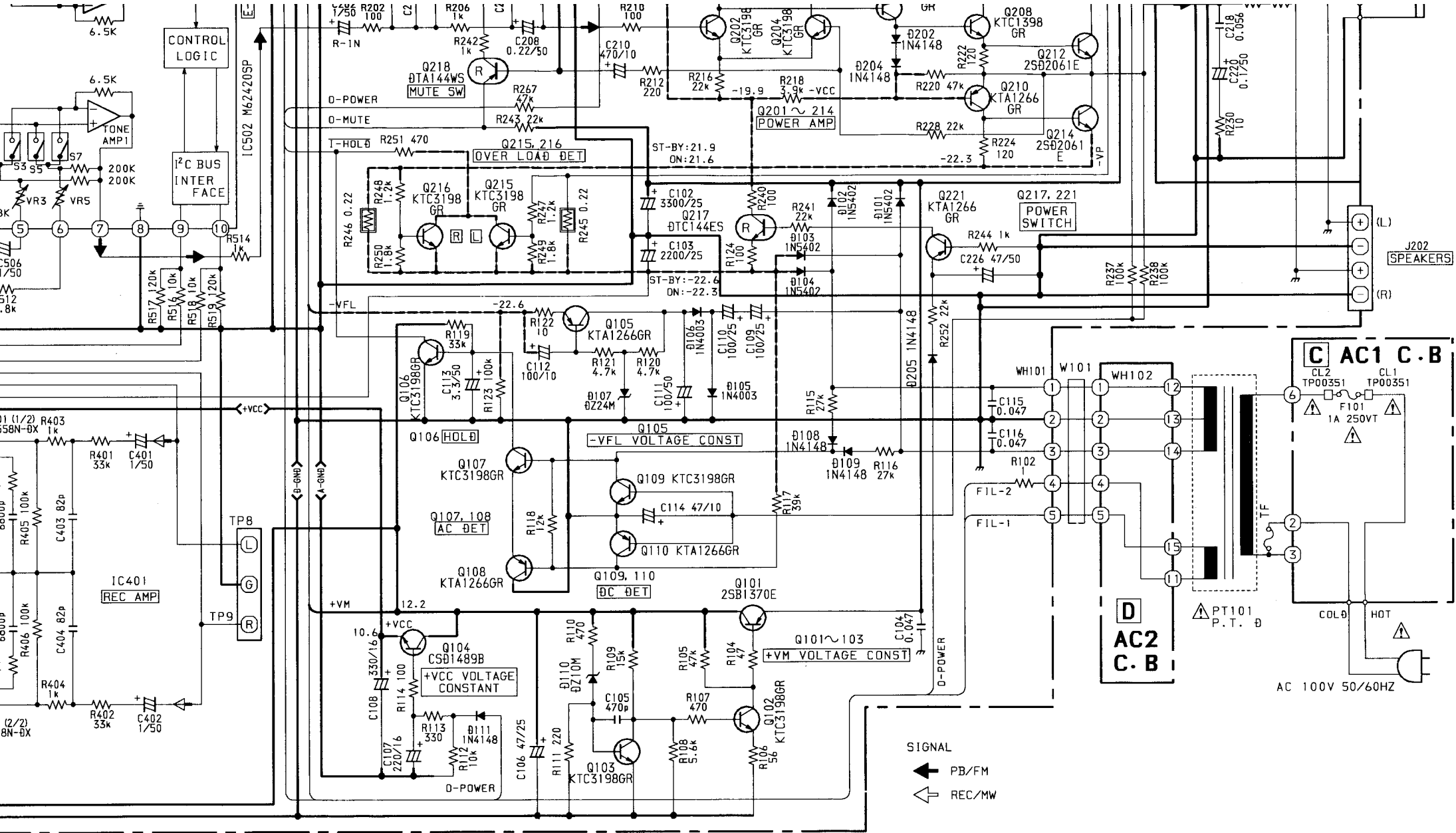

SCHEMATIC DIAGRAM - 2 (MAIN : HR)

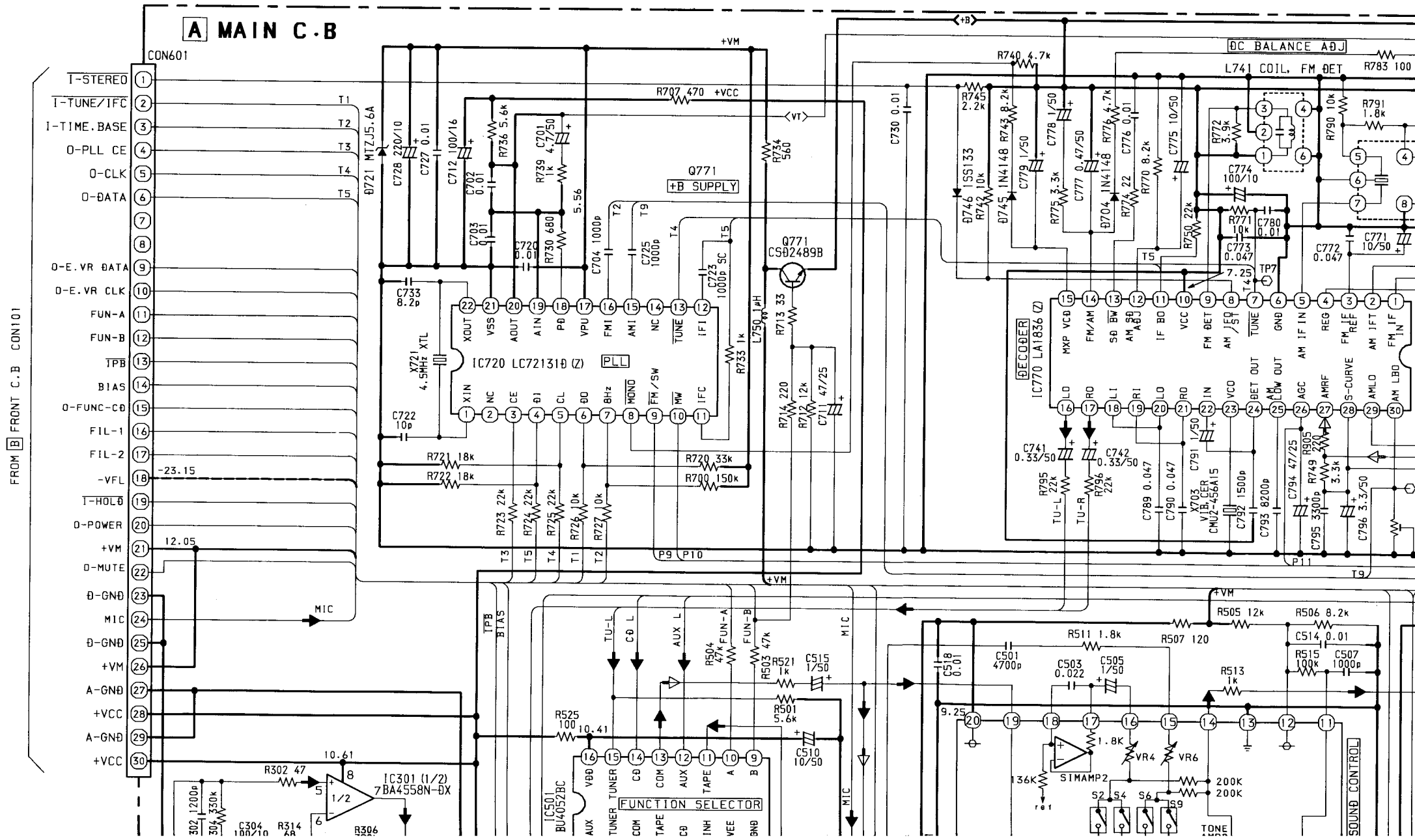

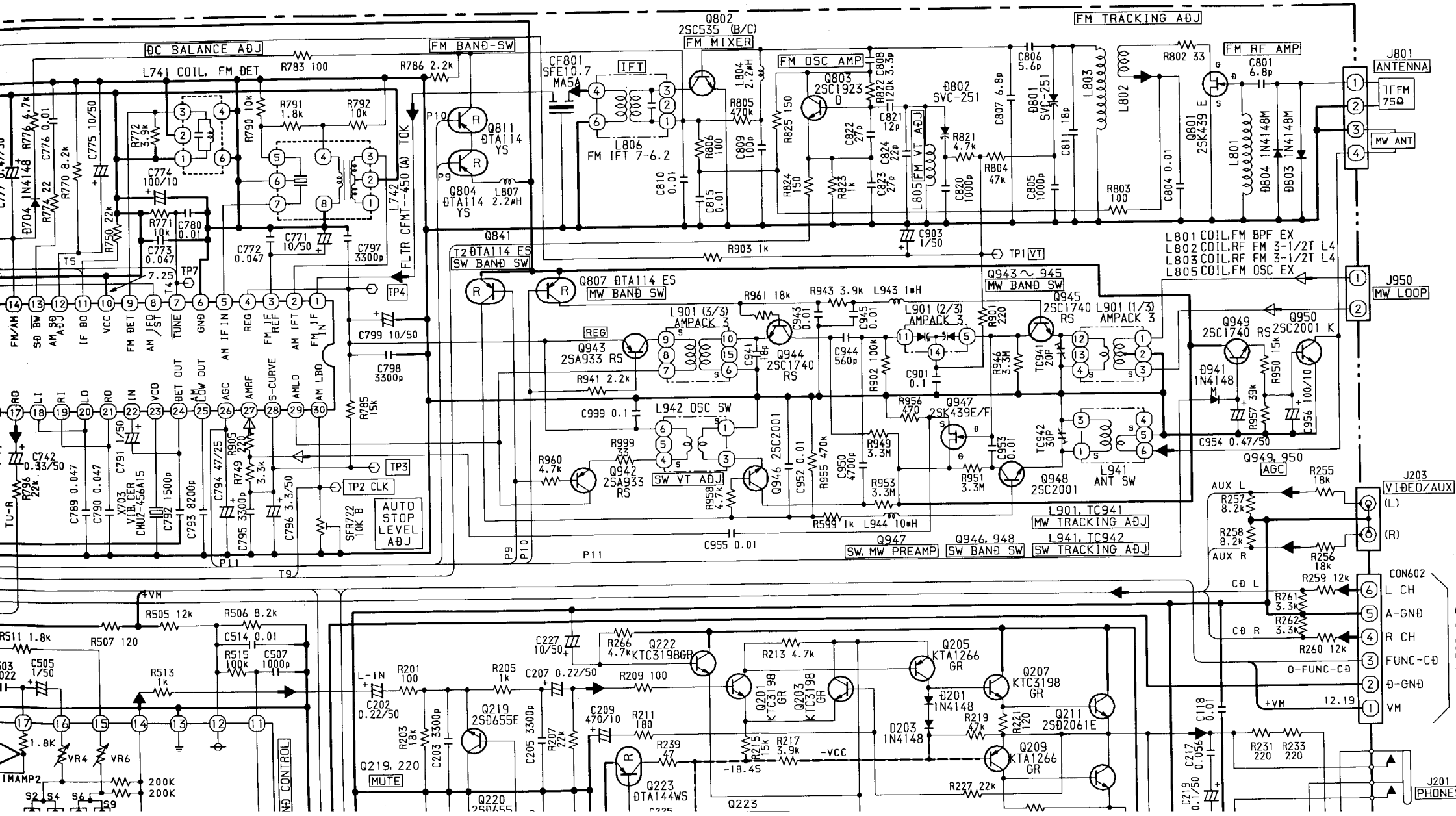

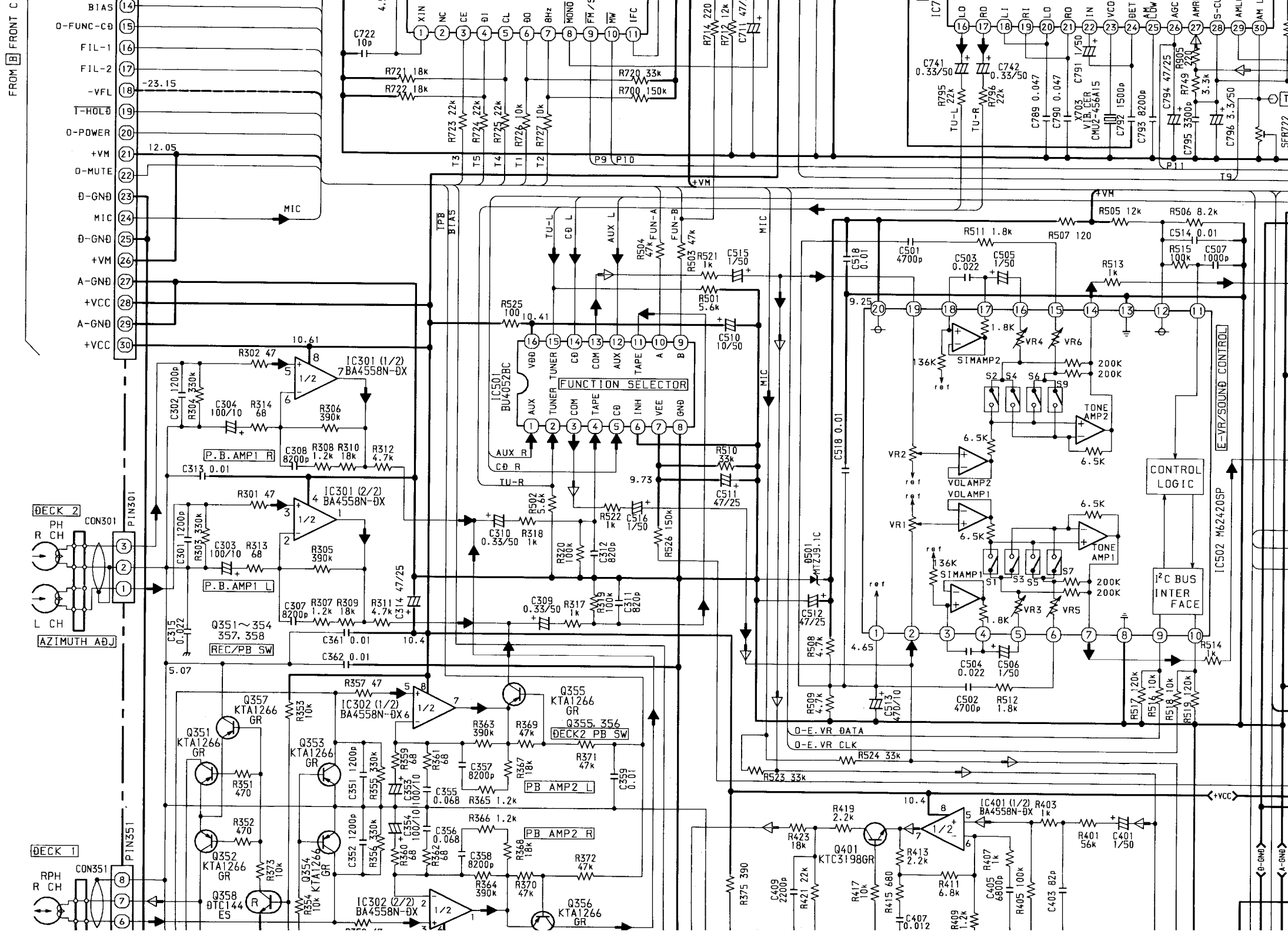

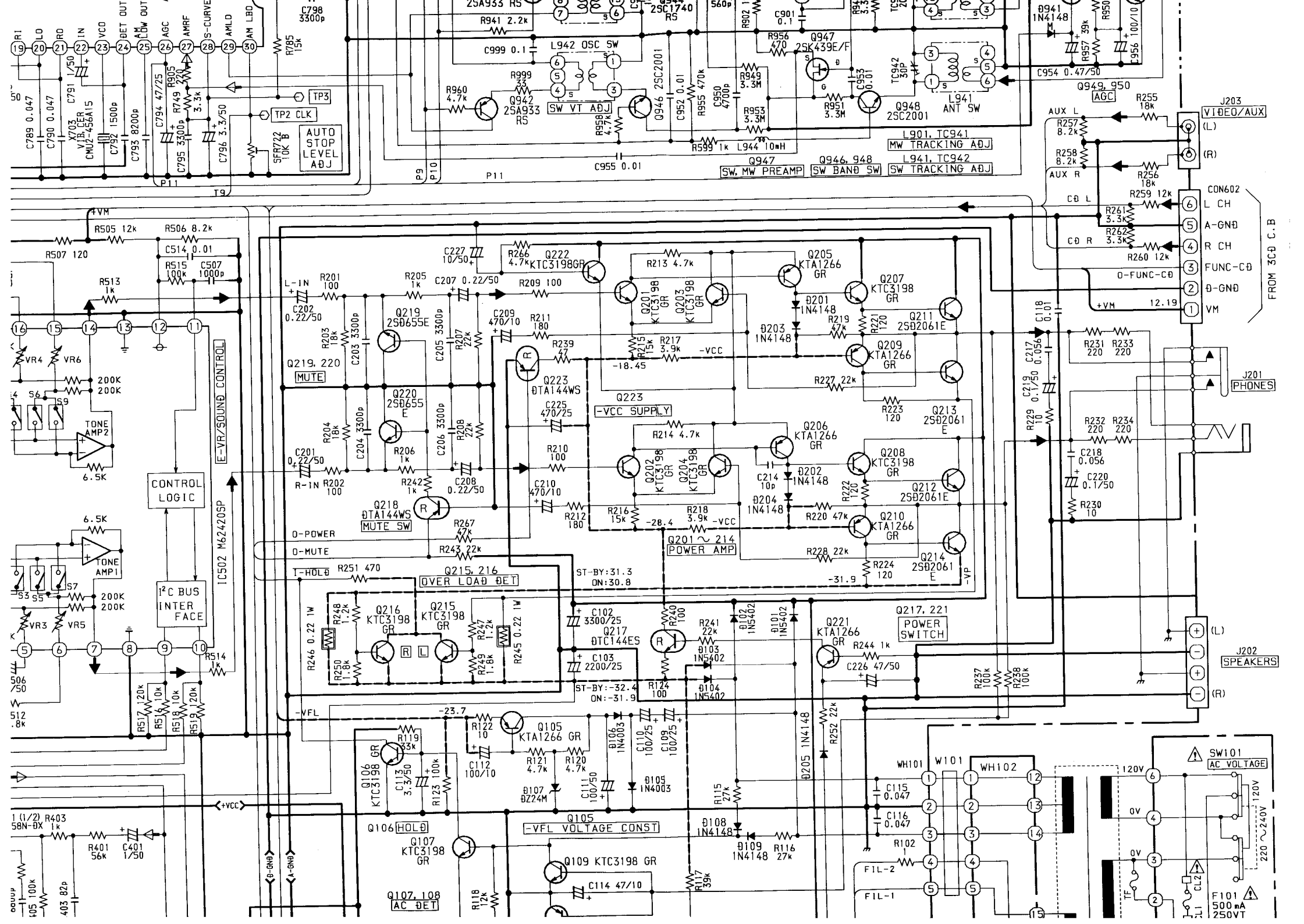

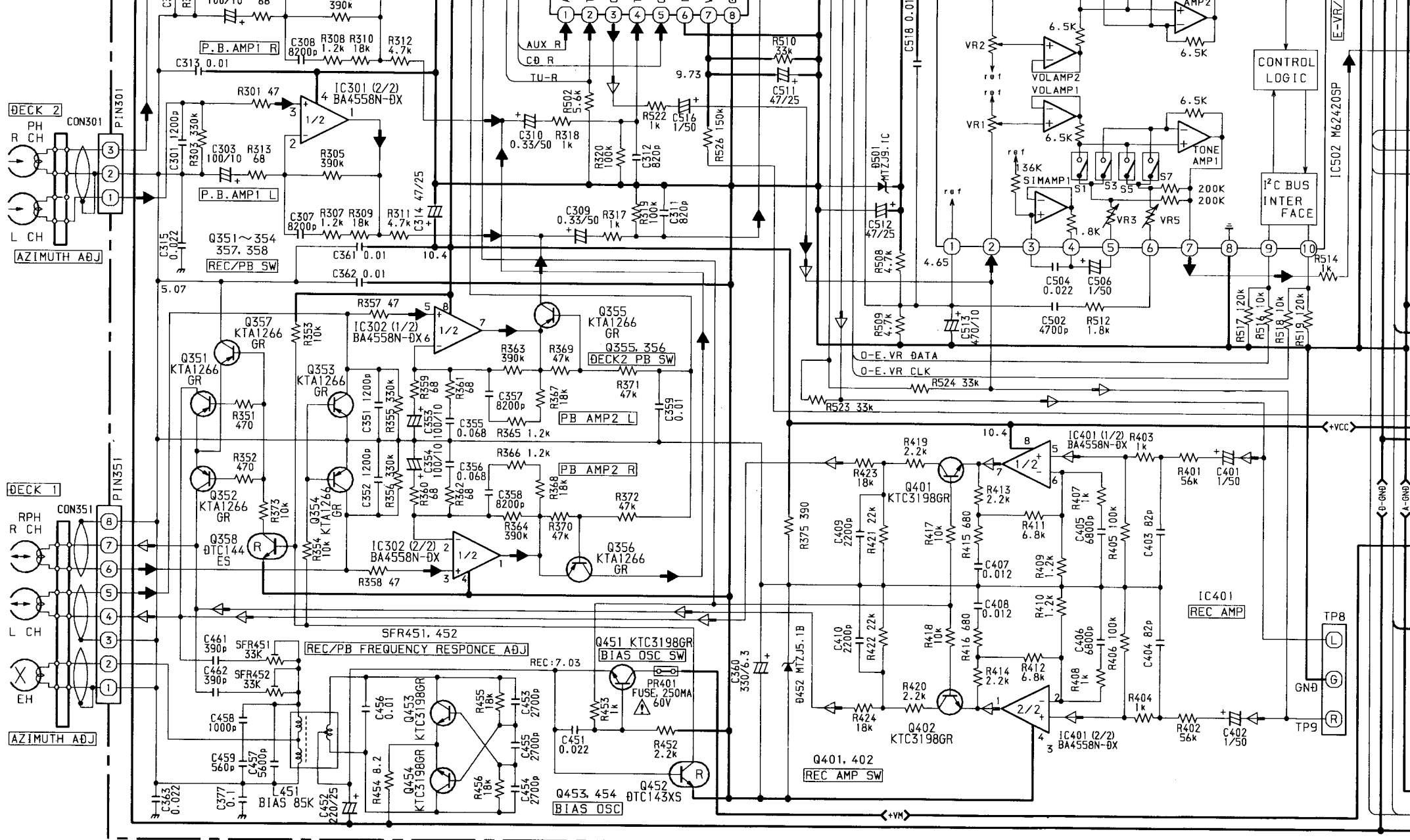

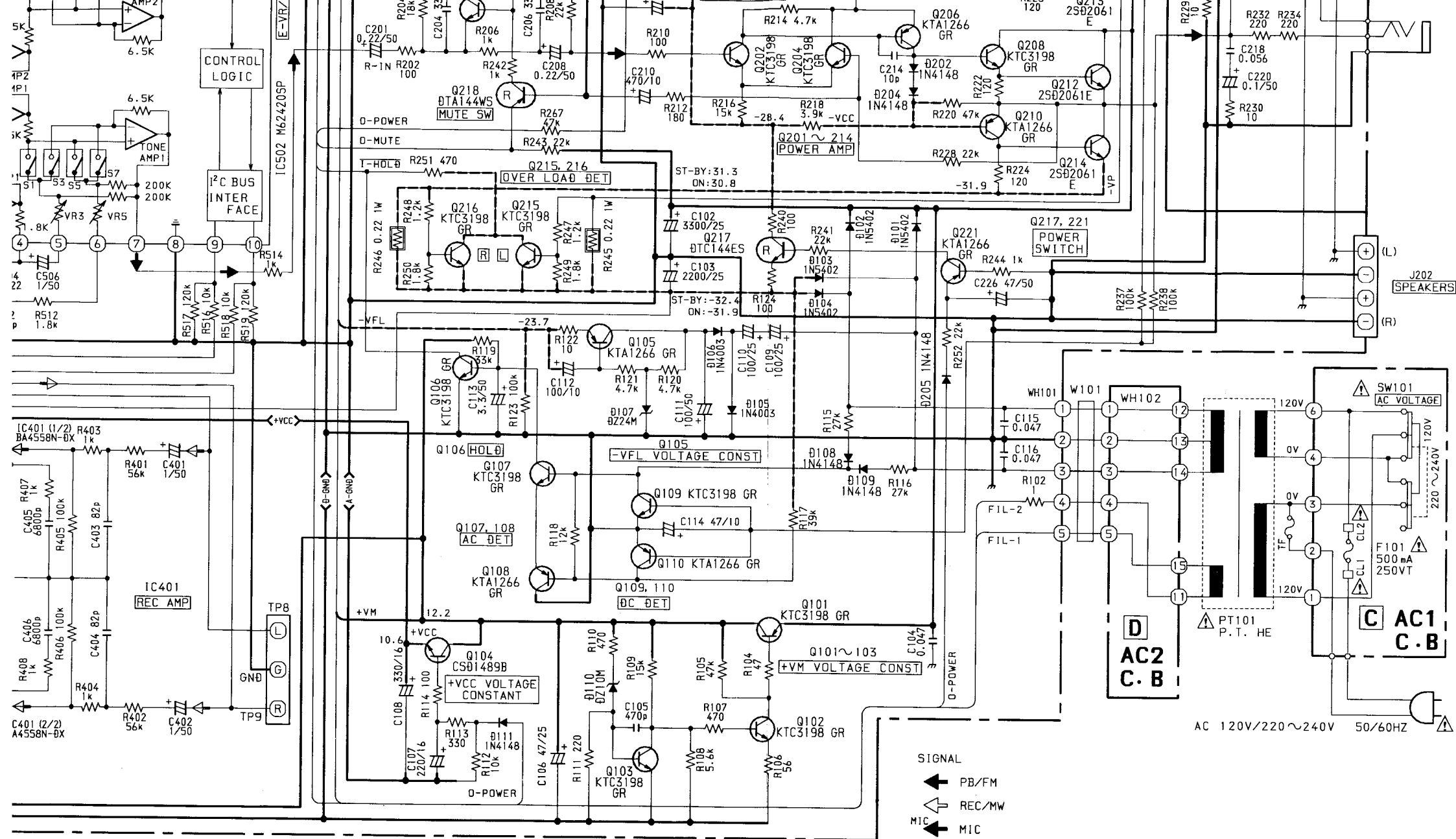

A MAIN C. B

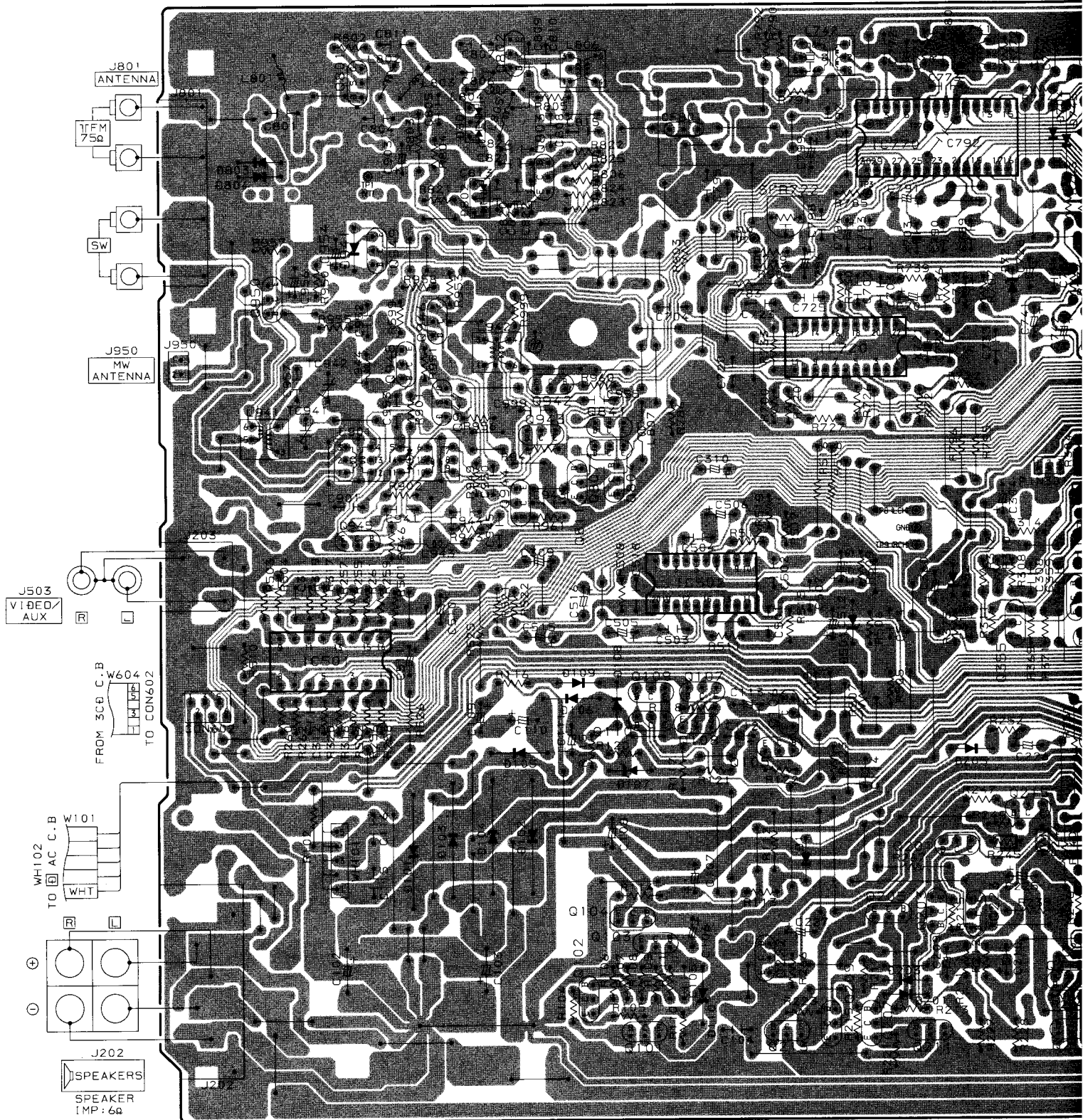

↑
TO PIN30
1 2 3
FROM DECK ME

WIRING - 3 (MAIN : HS)

1 2 3 4 5 6 7 8

A
B
C
D
E
F
G
H
I
J

A MAIN C.B

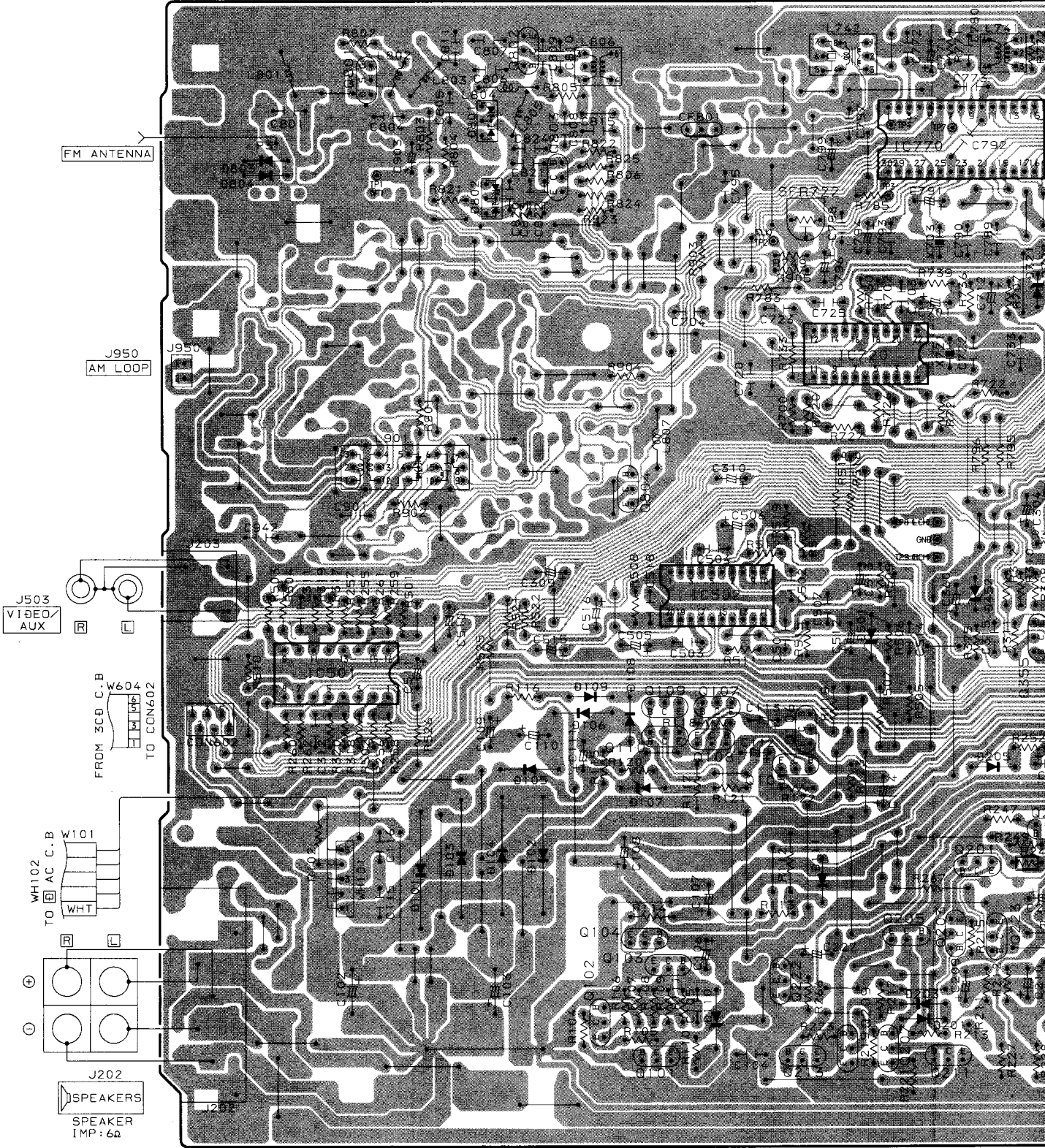

TO
FROM

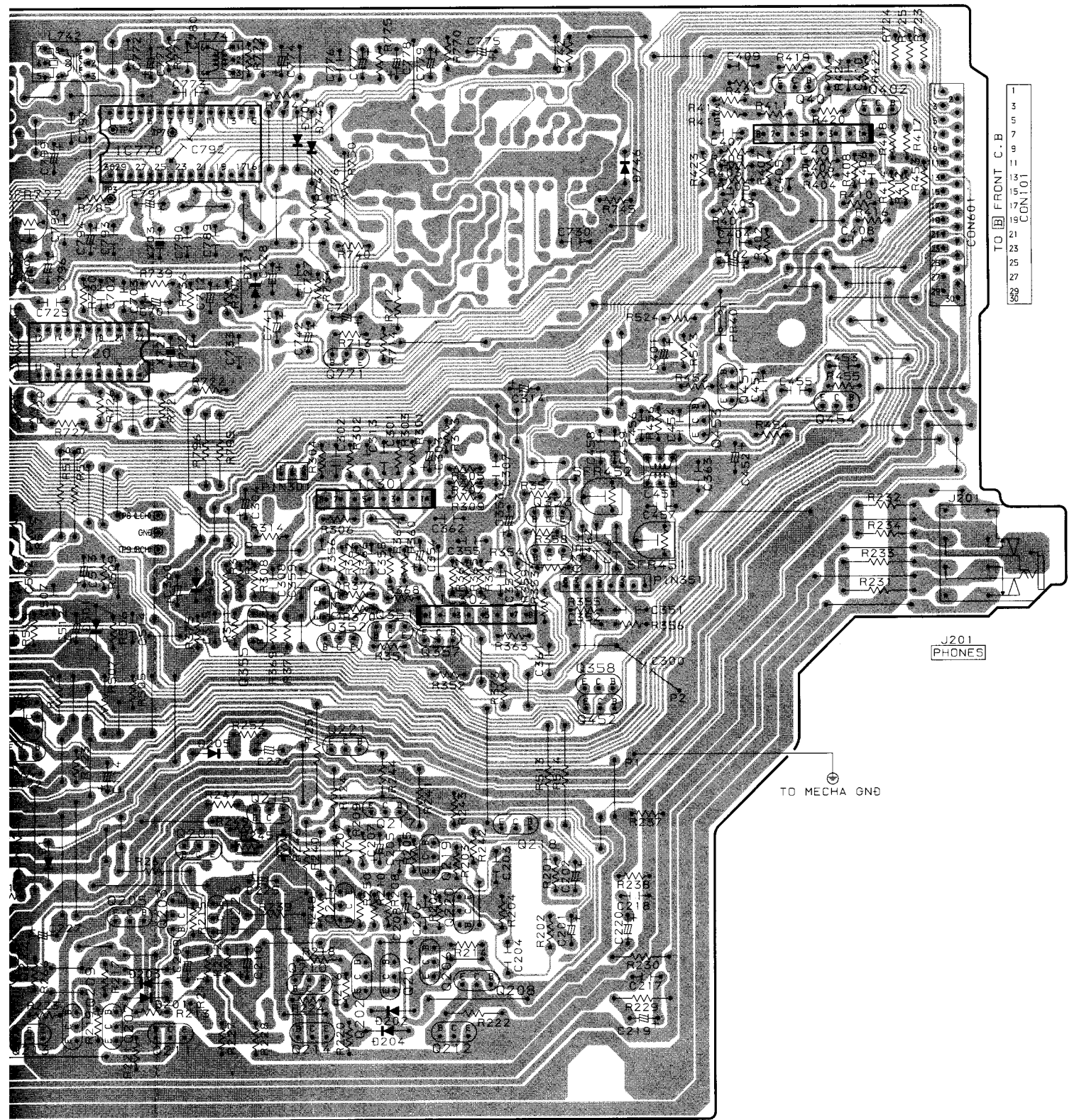

TO FRONT C.B.
CON101

J201
PHONES

TO MECHA GND

↑
TO PIN301
FROM DECK MECHA

↑
TO PIN351
FROM DECK MECHA

SCHEMATIC DIAGRAM - 3 (MAIN : HS)

FROM FRONT C.B CON101

A MAIN C.B

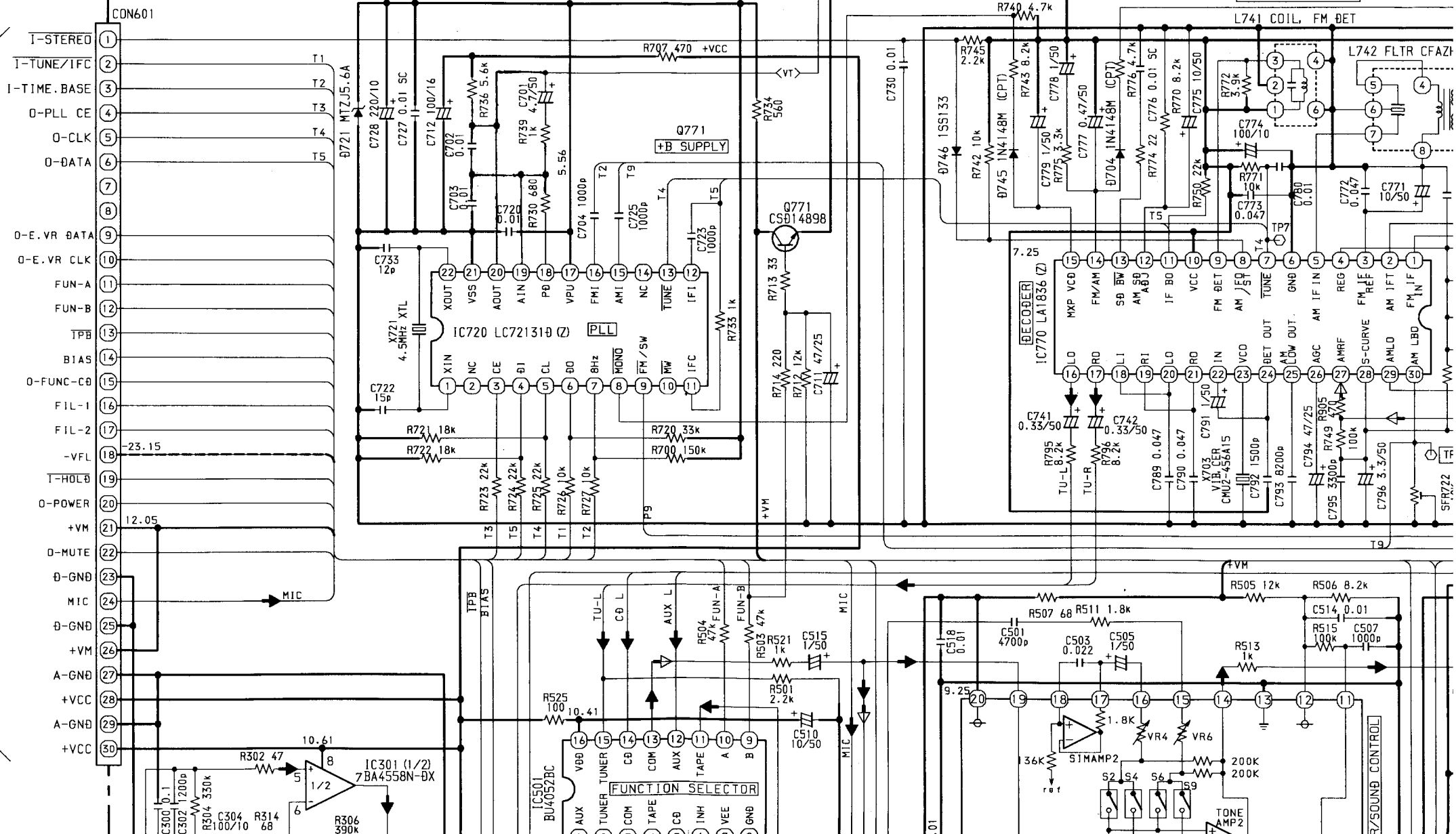

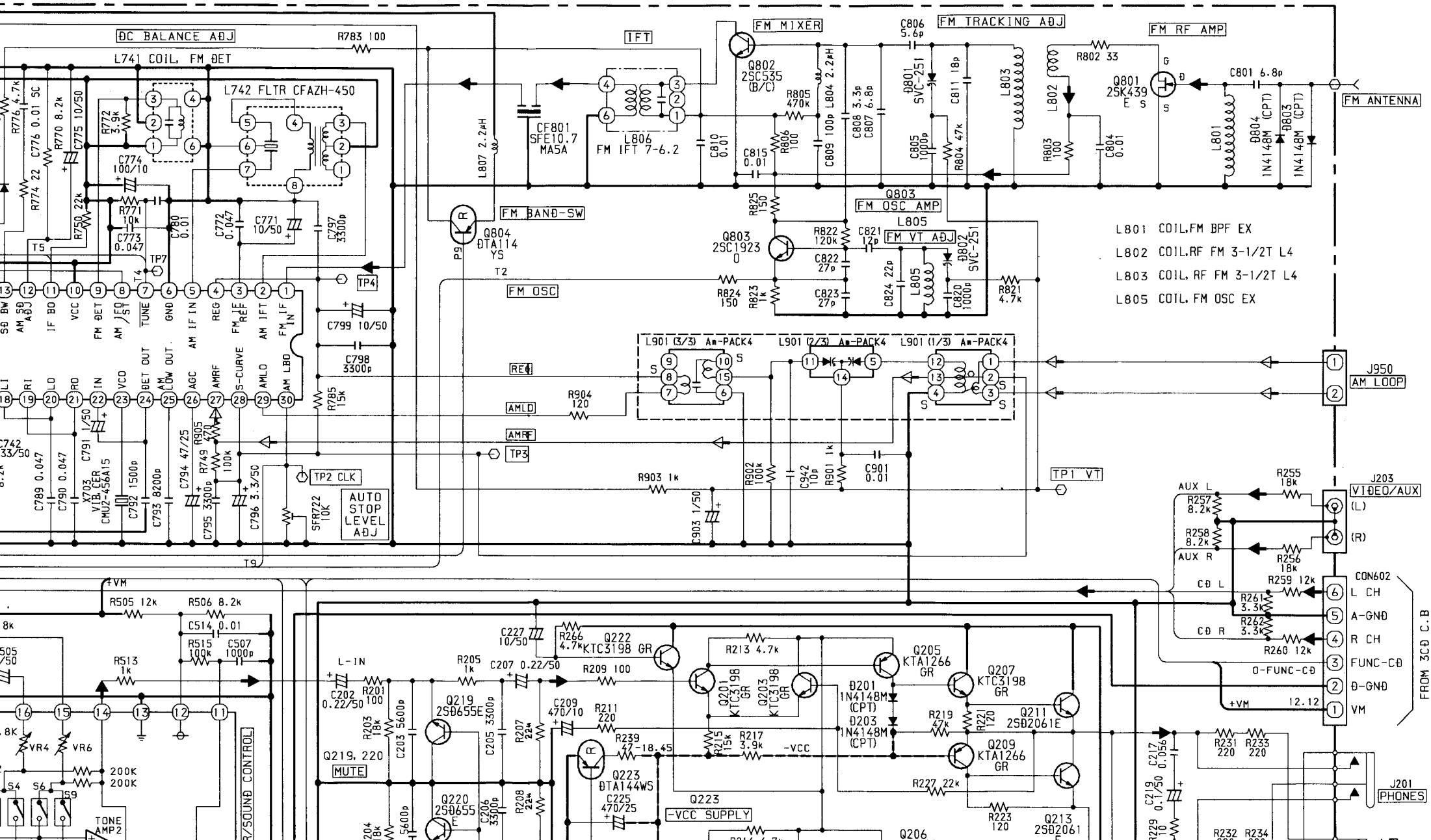

FROM FRONT C. B CONT

- FUN-A (12)
- FUN-B (13)
- TPB (14)
- BIAS (15)
- O-FUNC-CB (16)
- FIL-1 (17)
- FIL-2 (18)
- VFL (19)
- T-HOLD (20)
- O-POWER (21)
- +VM (22)
- O-MUTE (23)
- Ø-GND (24)
- MIC (25)
- Ø-GND (26)
- +VM (27)
- A-GND (28)
- +VCC (29)
- A-GND (30)
- +VCC (31)

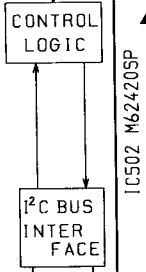
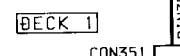
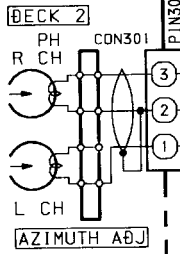
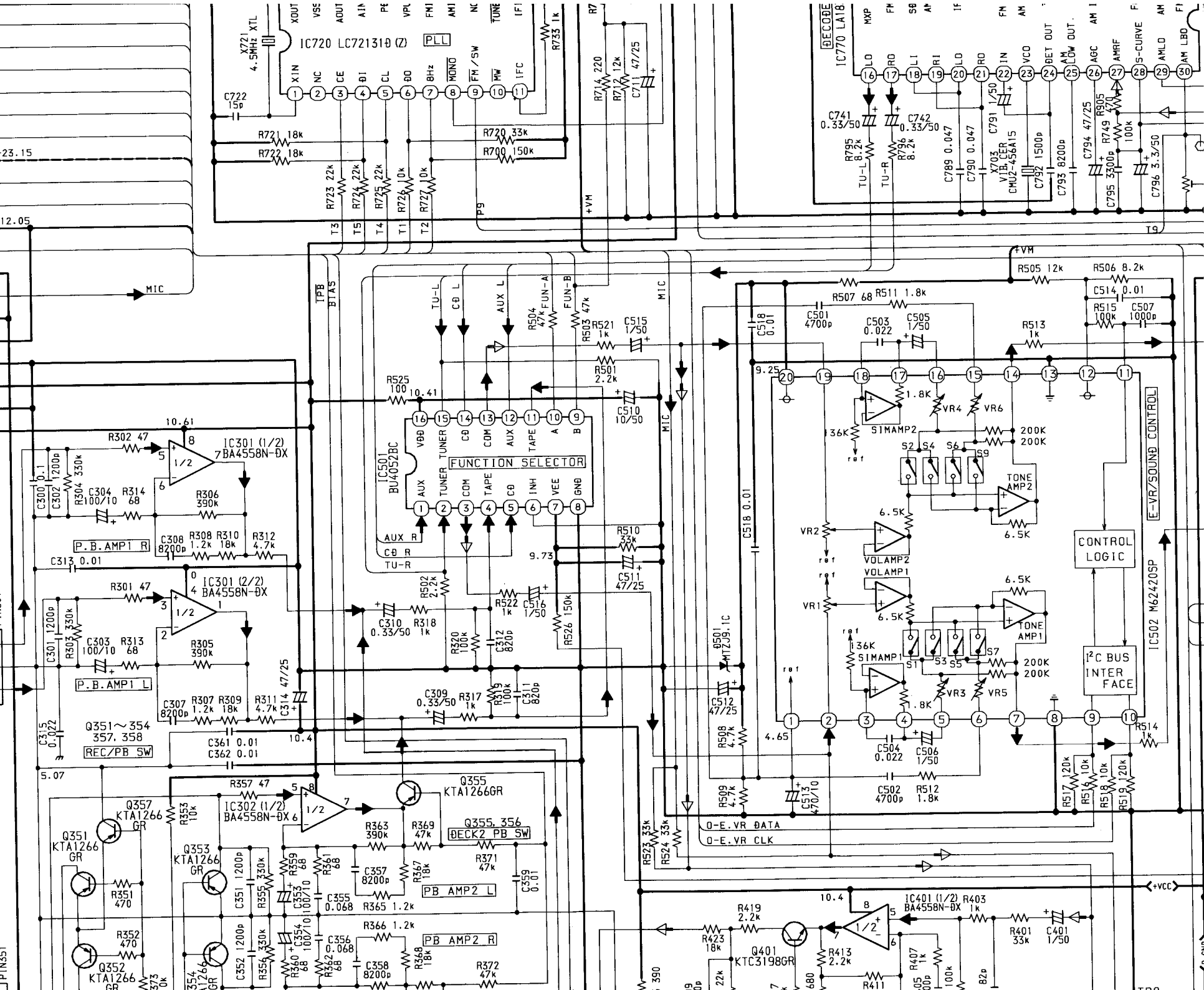

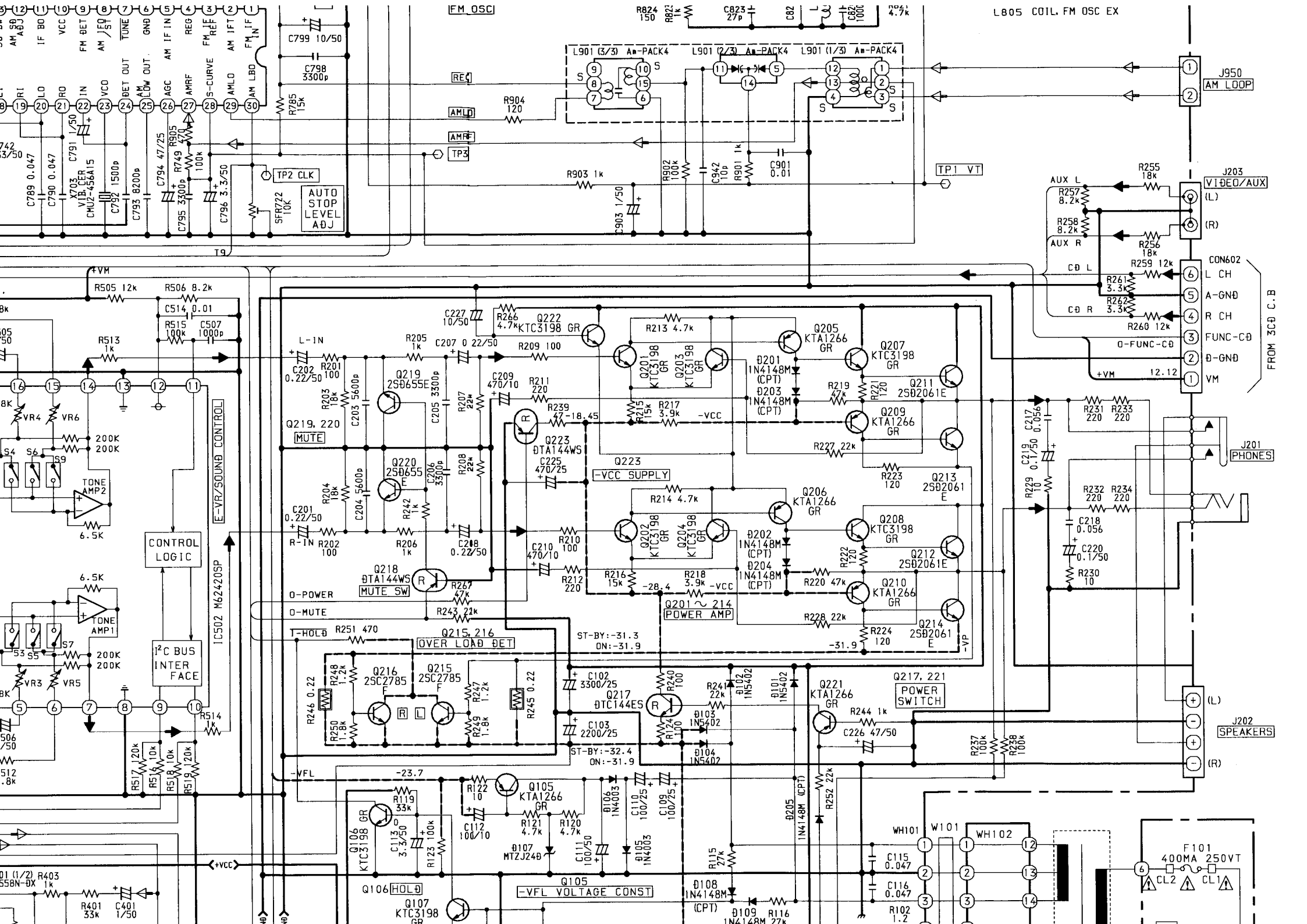

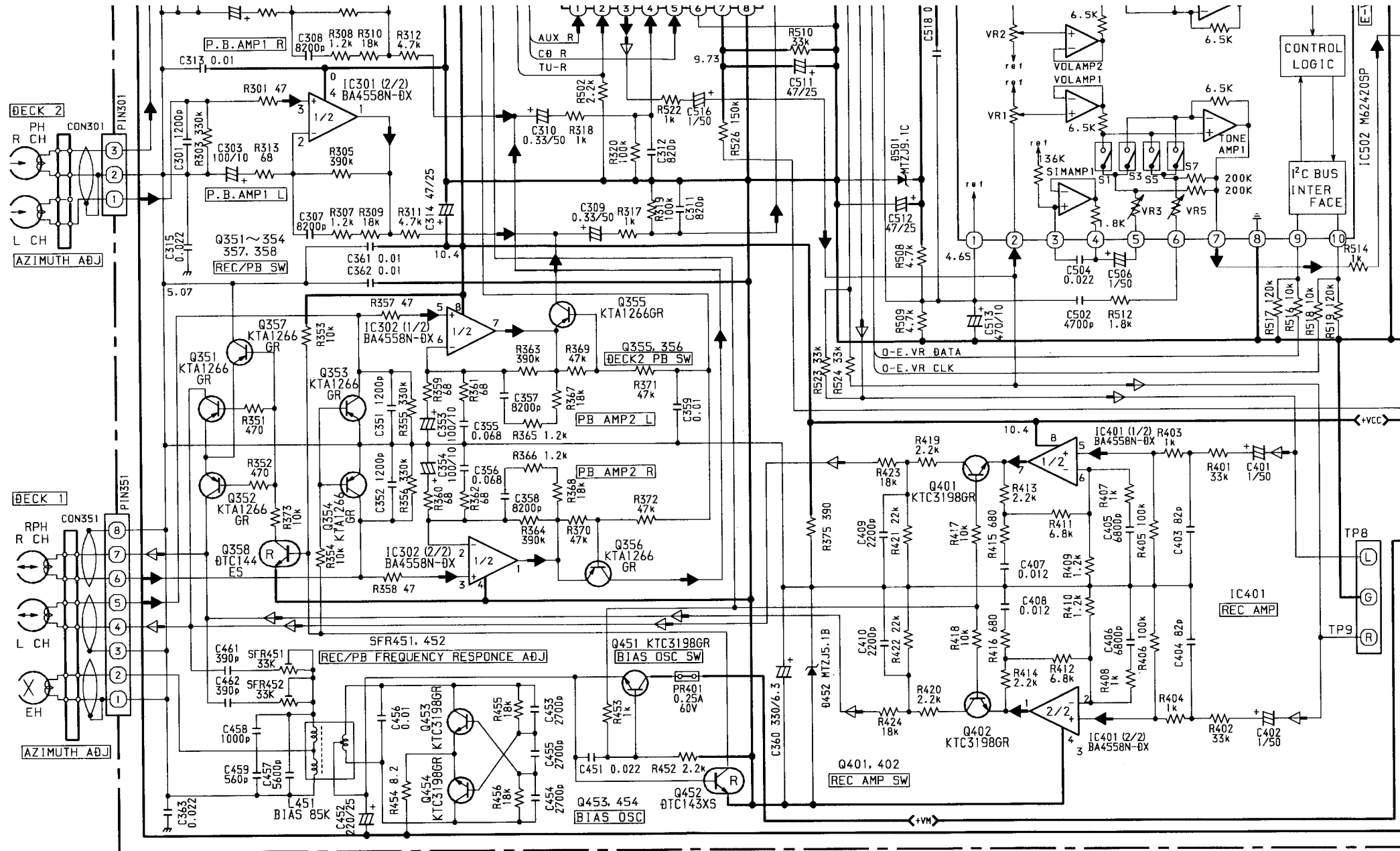

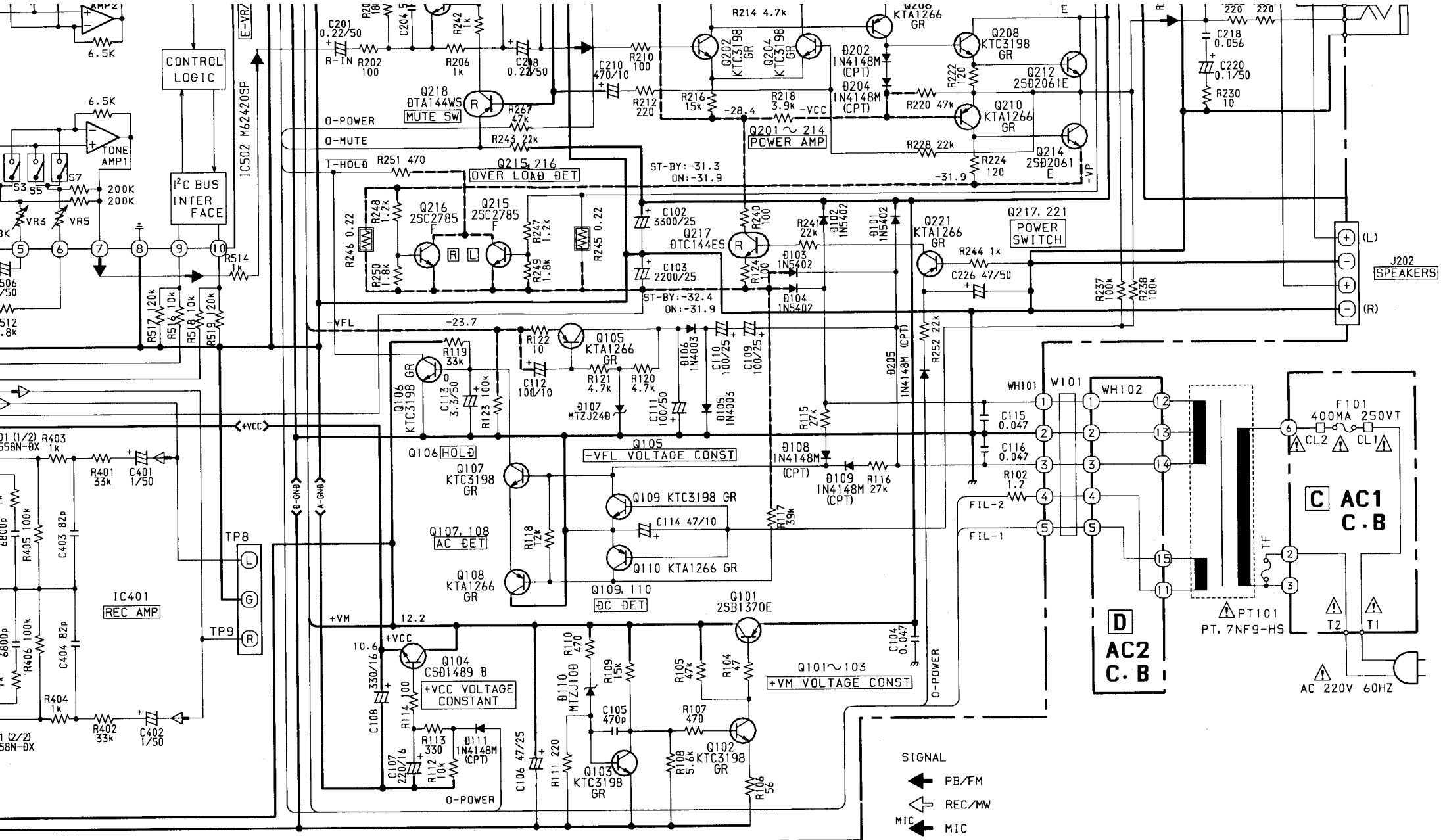

SCHEMATIC DIAGRAM - 4 (MAIN : 9EZ, G)

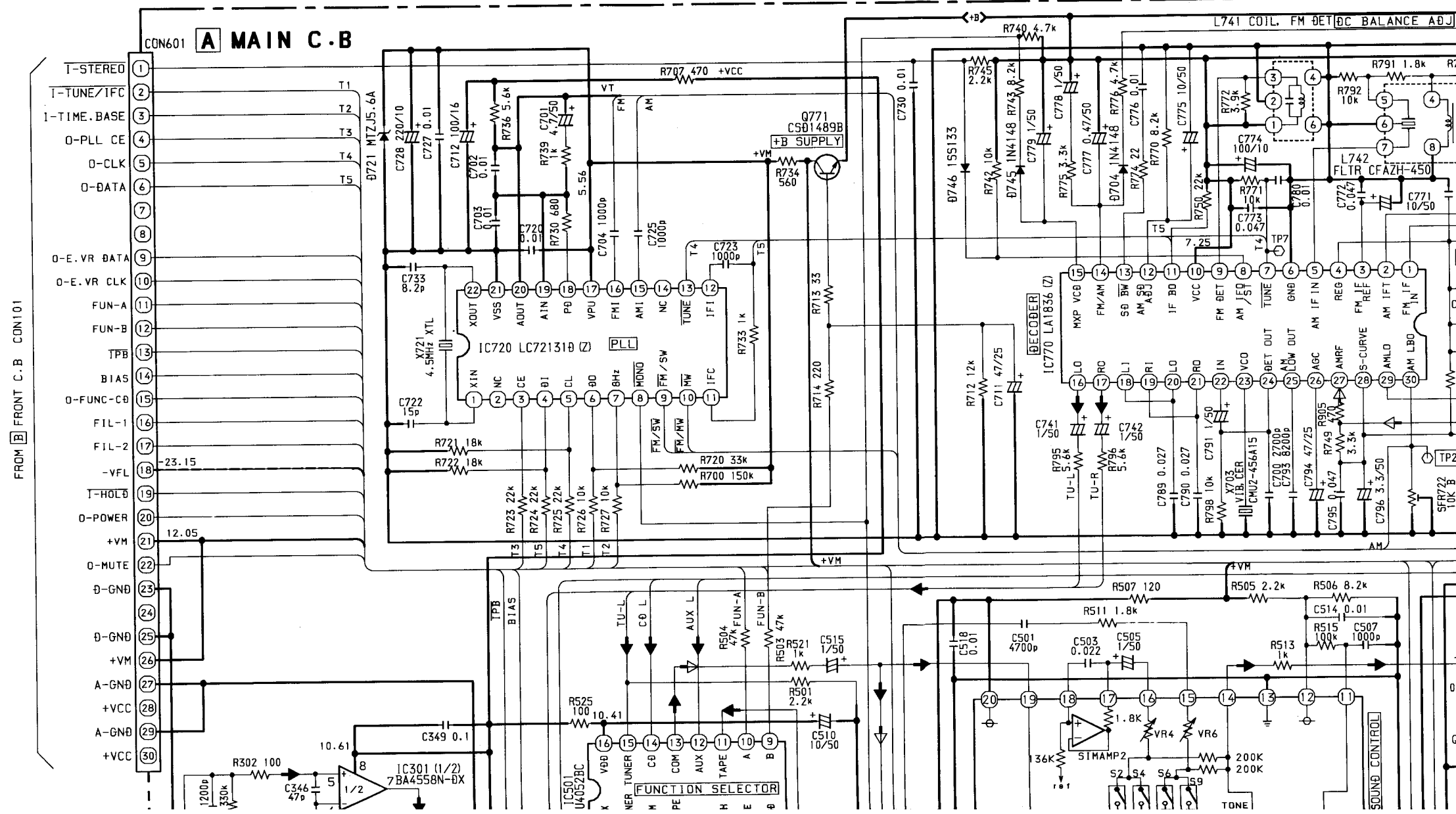

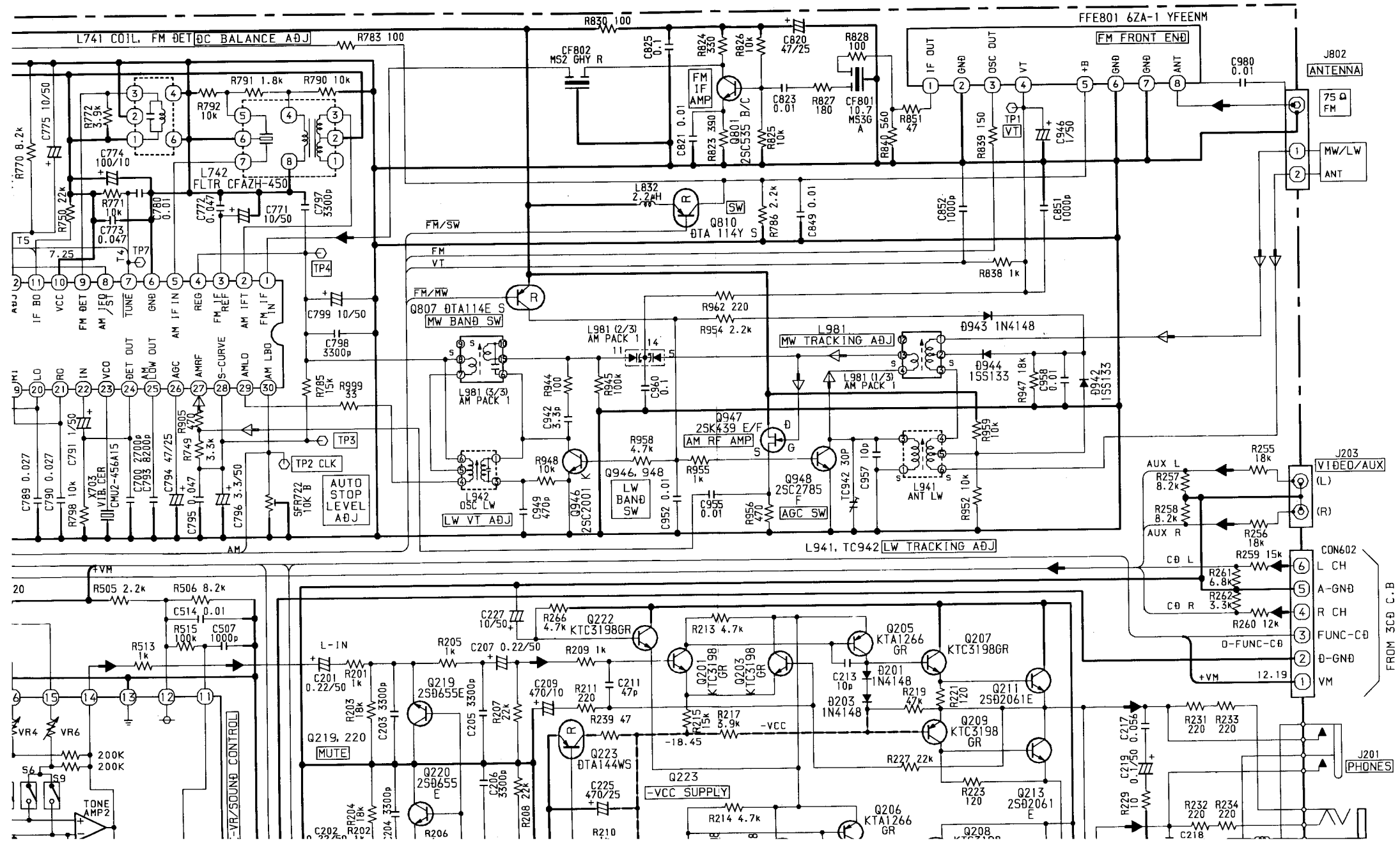

FROM FRONT C.B. COM

- FUN-B (12)
- TPB (13)
- BIAS (14)
- O-FUNC-C0 (15)
- FIL-1 (16)
- FIL-2 (17)
- VFL (18) -23.15
- T-HOLD (19)
- O-POWER (20)
- +VM (21) 12.05
- O-MUTE (22)
- 0-GND (23)
- 0-GND (24)
- 0-GND (25)
- +VM (26)
- A-GND (27)
- +VCC (28)
- A-GND (29)
- +VCC (30)

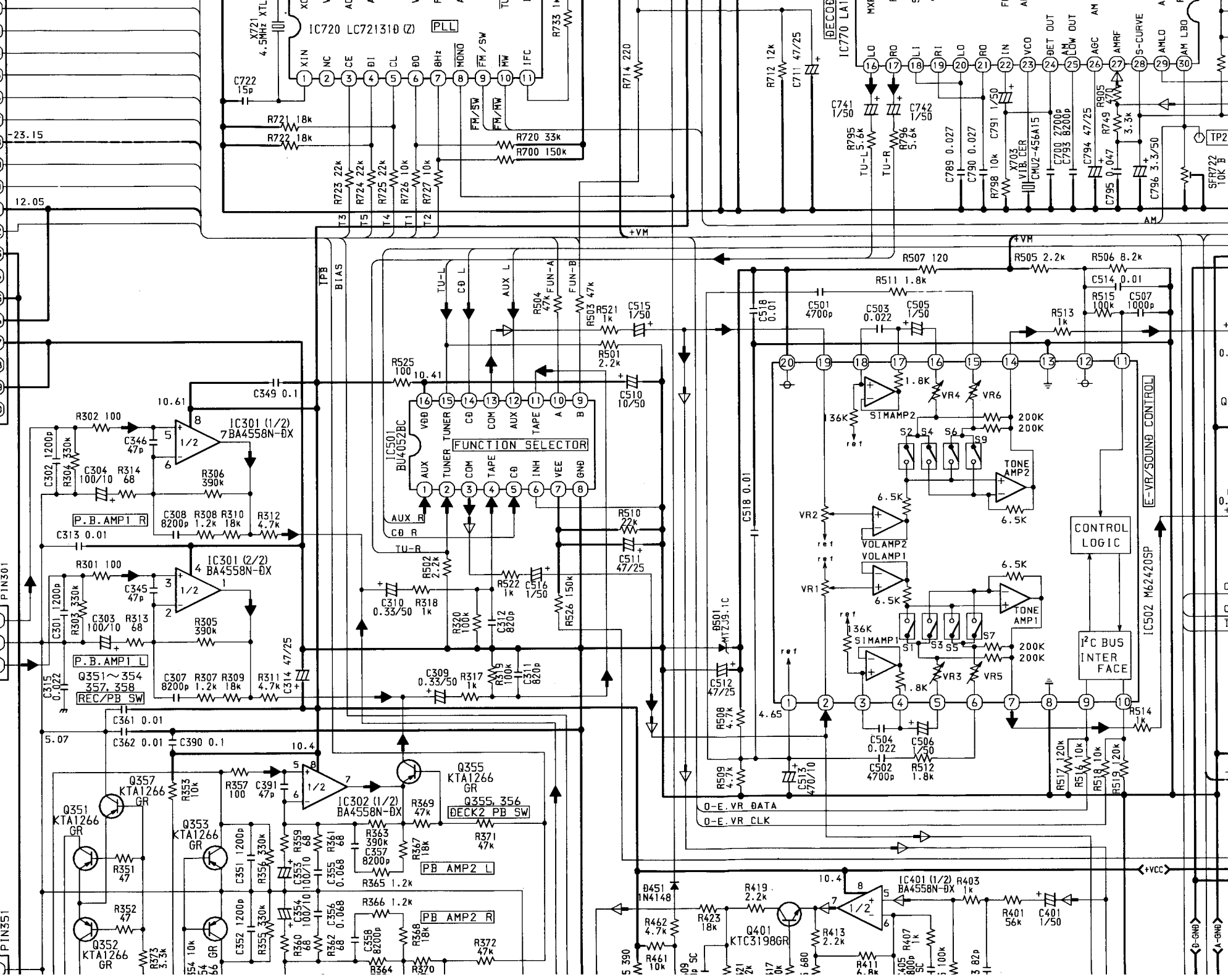
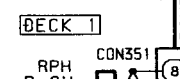
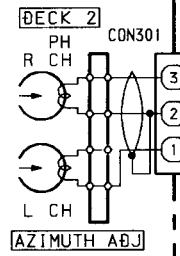

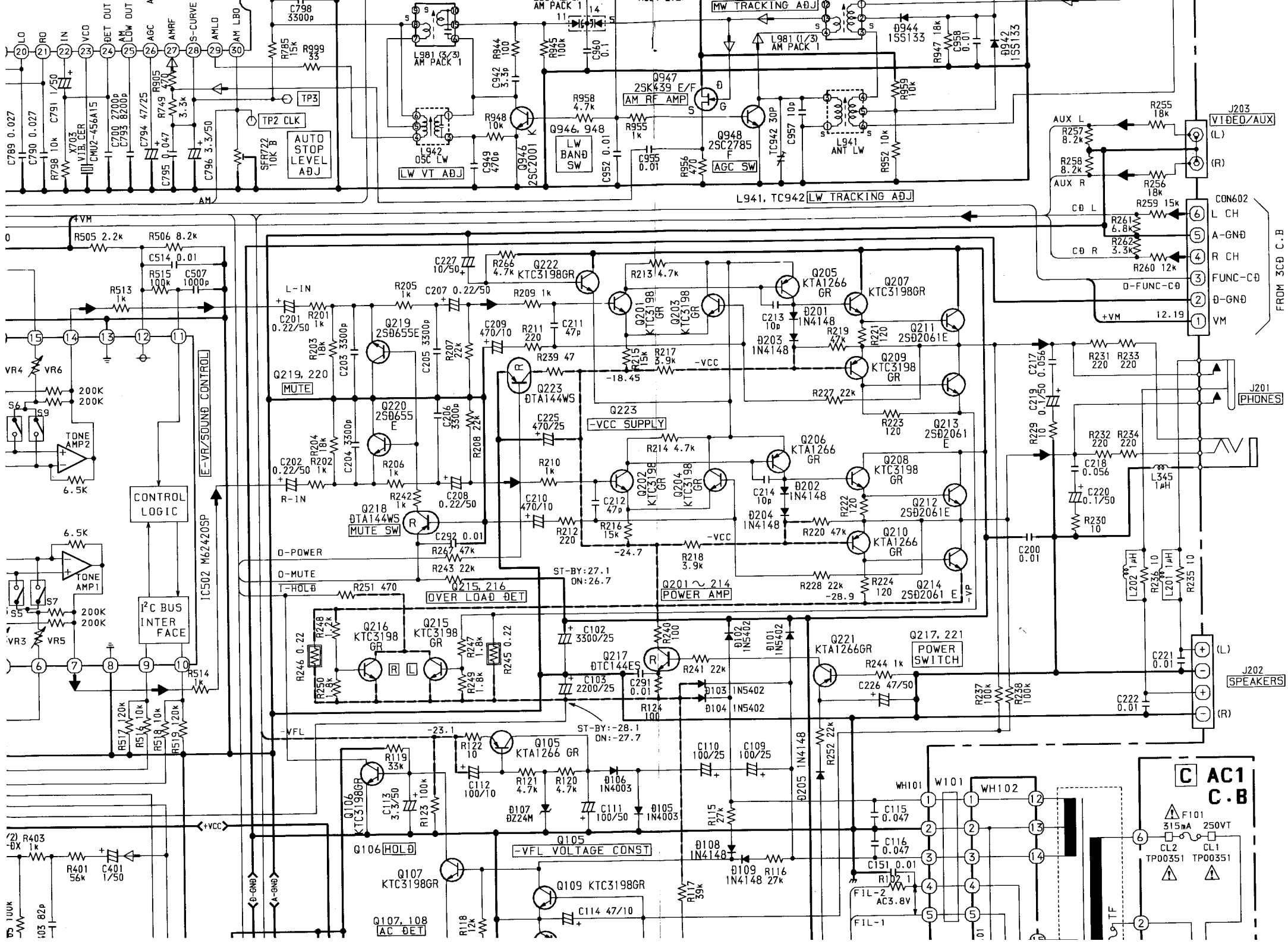

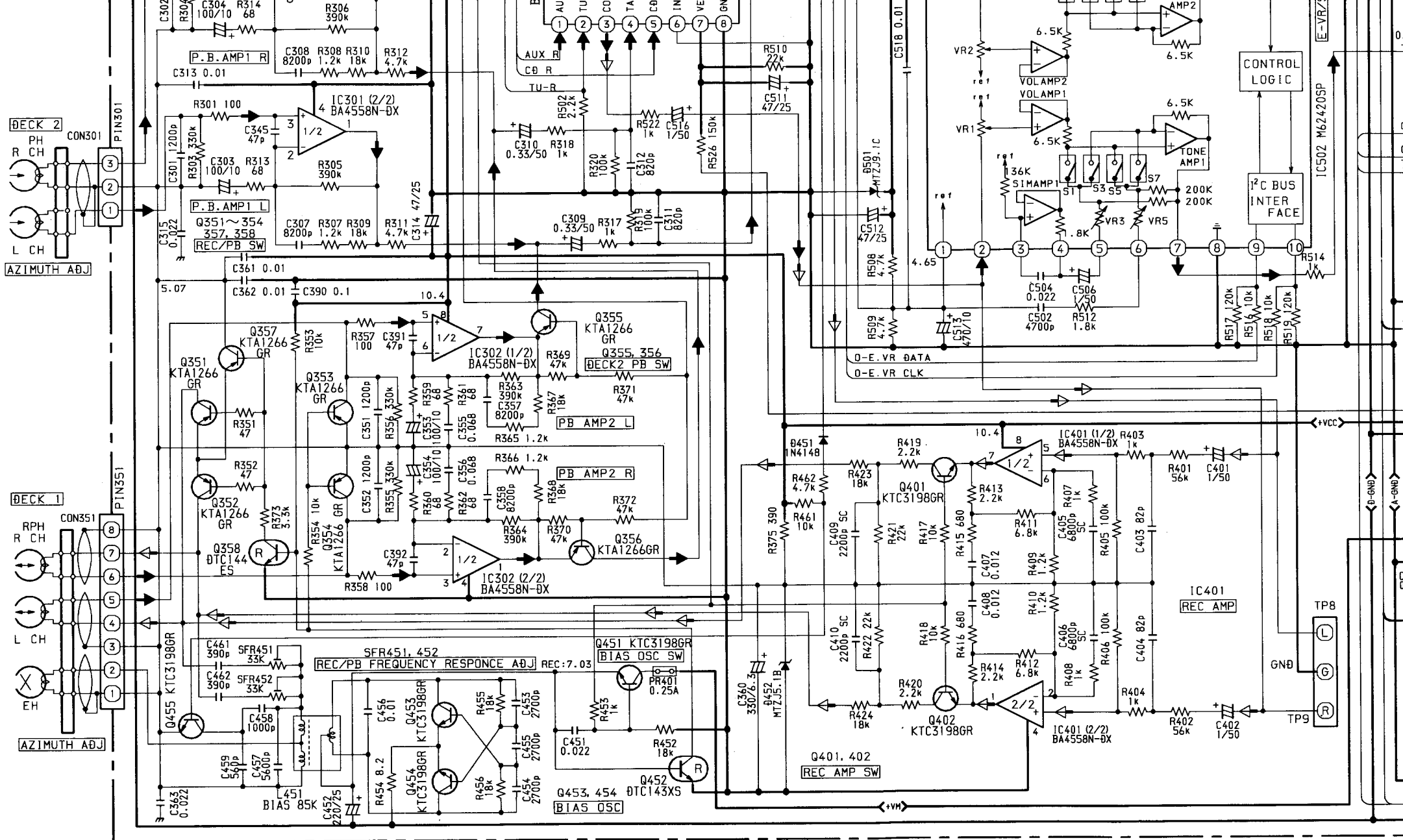

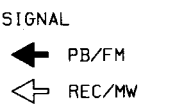
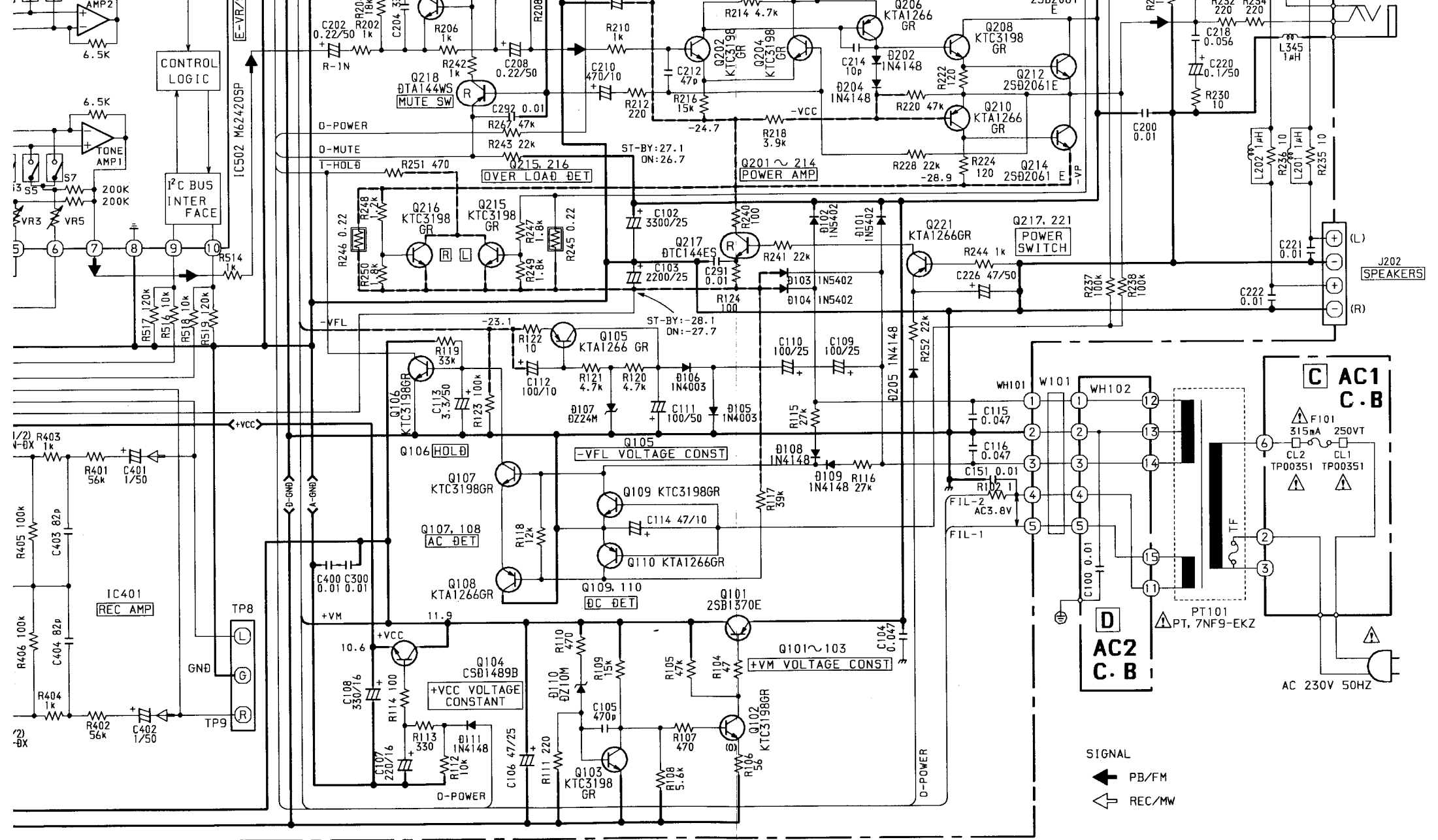

1 2 3 4 5 6 7 8

A
B
C
D
E
F
G
H
I
J

A MAIN C.B

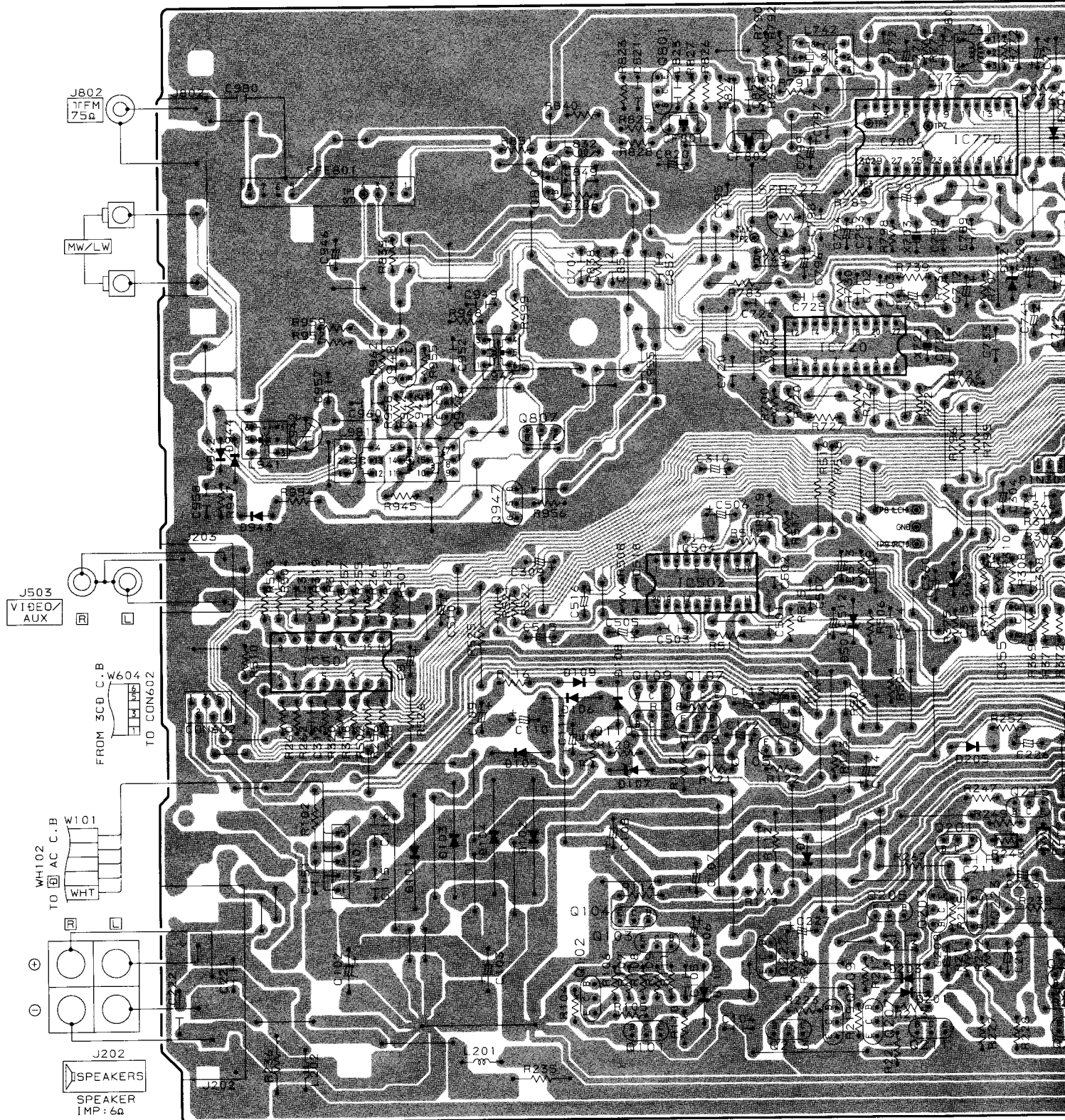

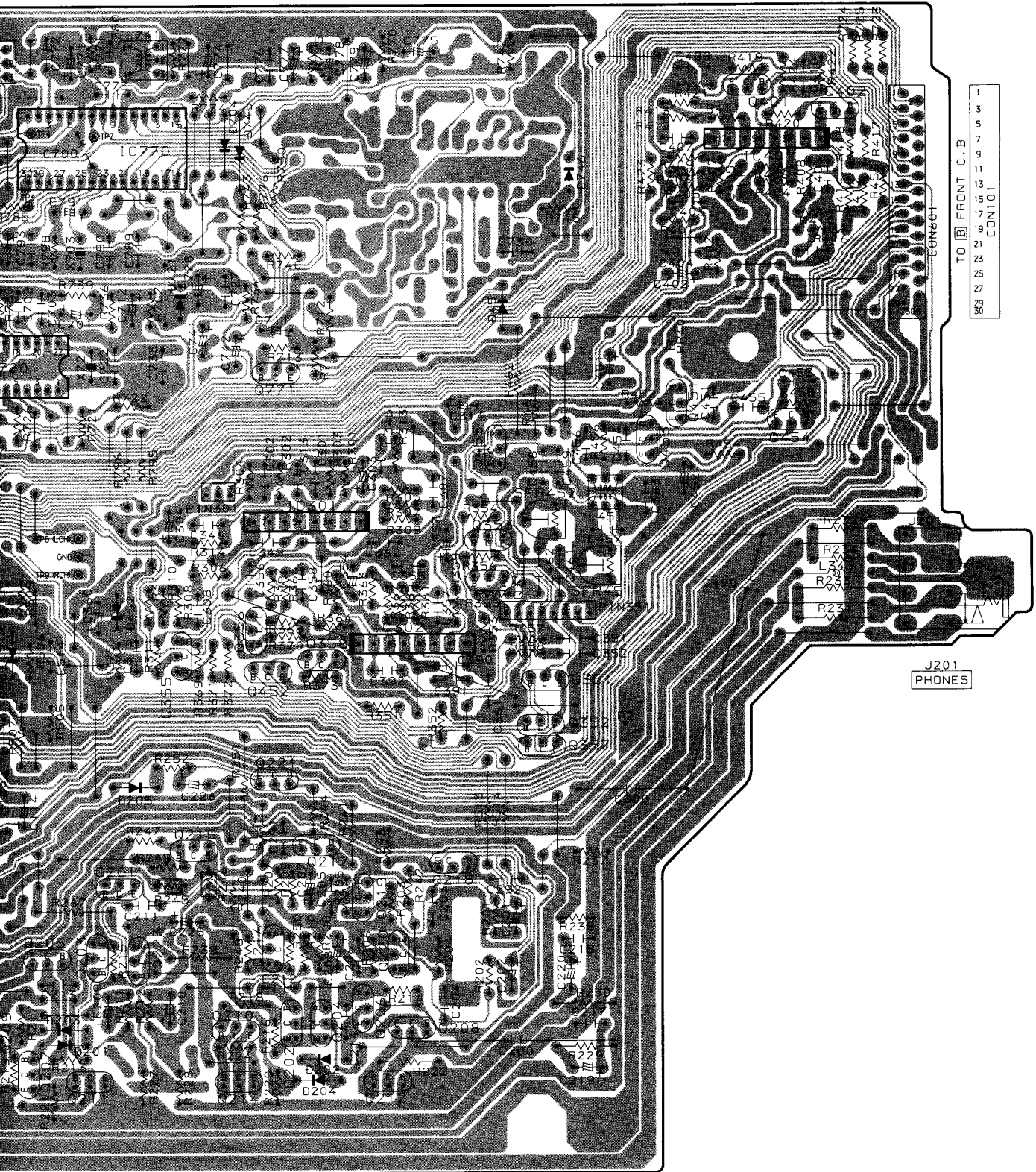

TO FRONT C.B.
 CON#01
 1
 3
 5
 7
 9
 11
 13
 15
 17
 19
 21
 23
 25
 27
 29
 31

J201
 PHONES

↑
 TO PIN301
 1 2 3
 FROM DECK MECHA

↑
 TO PIN351
 8 7 5 3 1
 FROM DECK MECHA

WIRING - 5 (MAIN : V)

1 2 3 4 5 6 7 8

A
B
C
D
E
F
G
H
I
J

A MAIN C.B

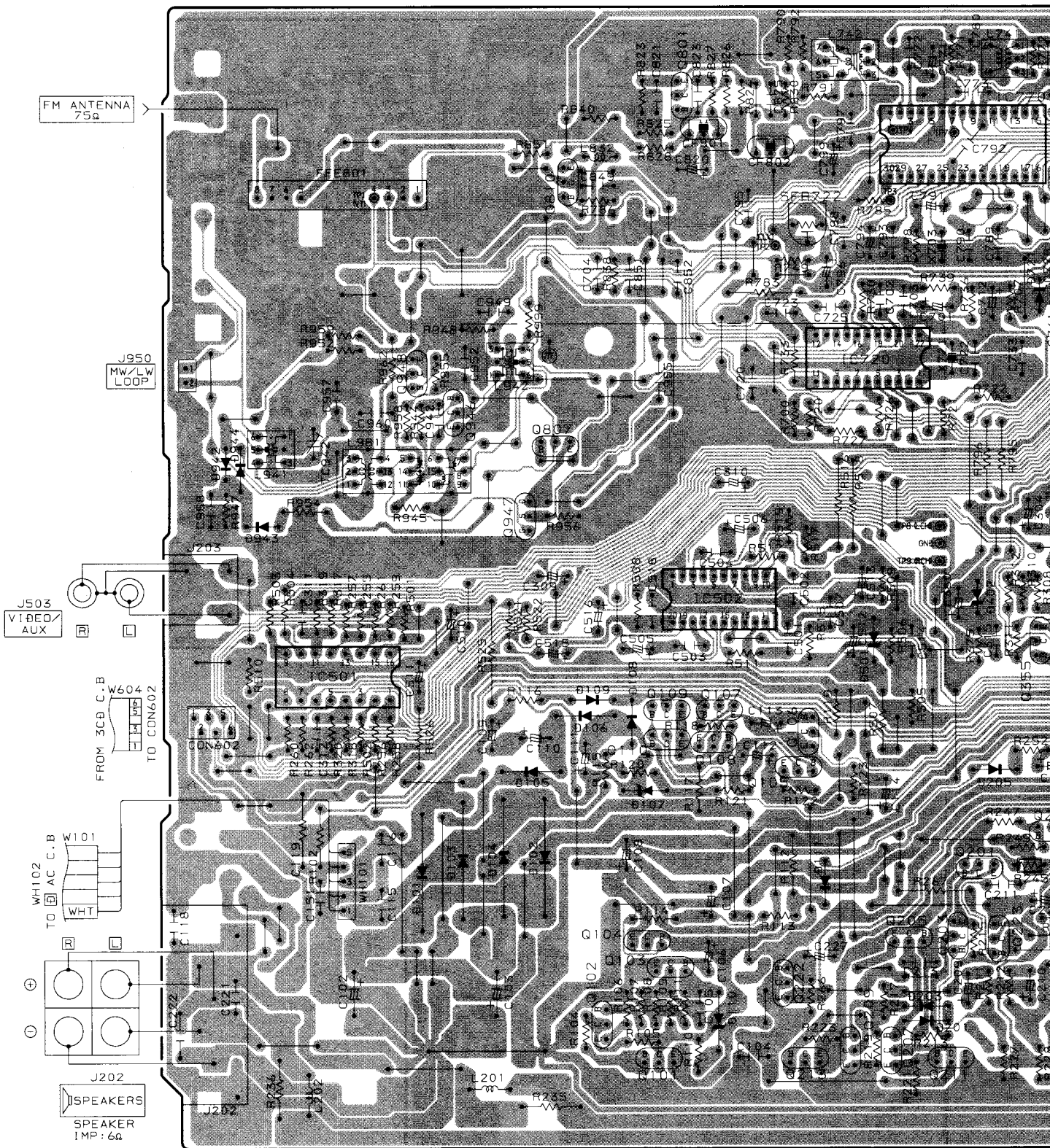

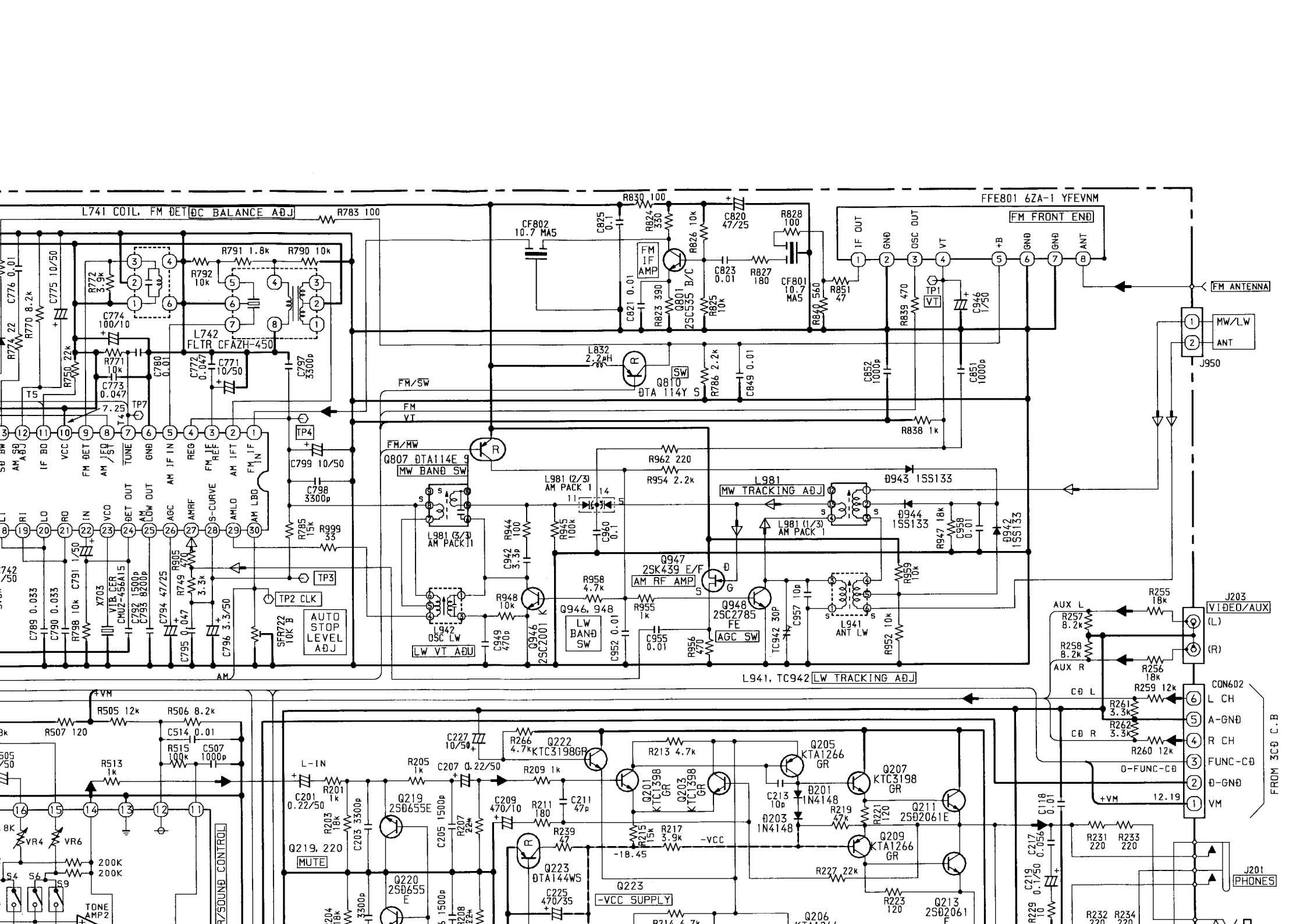

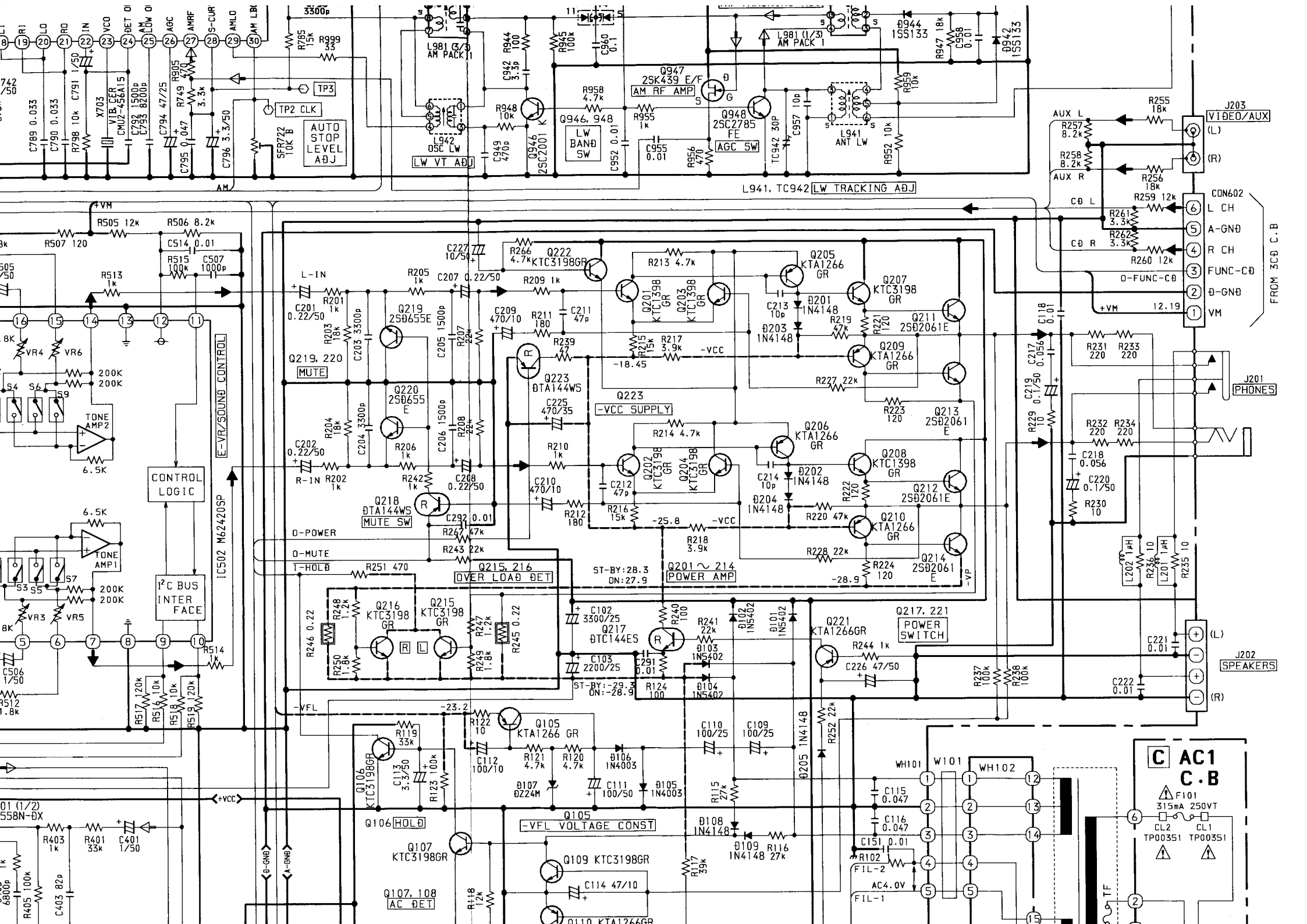

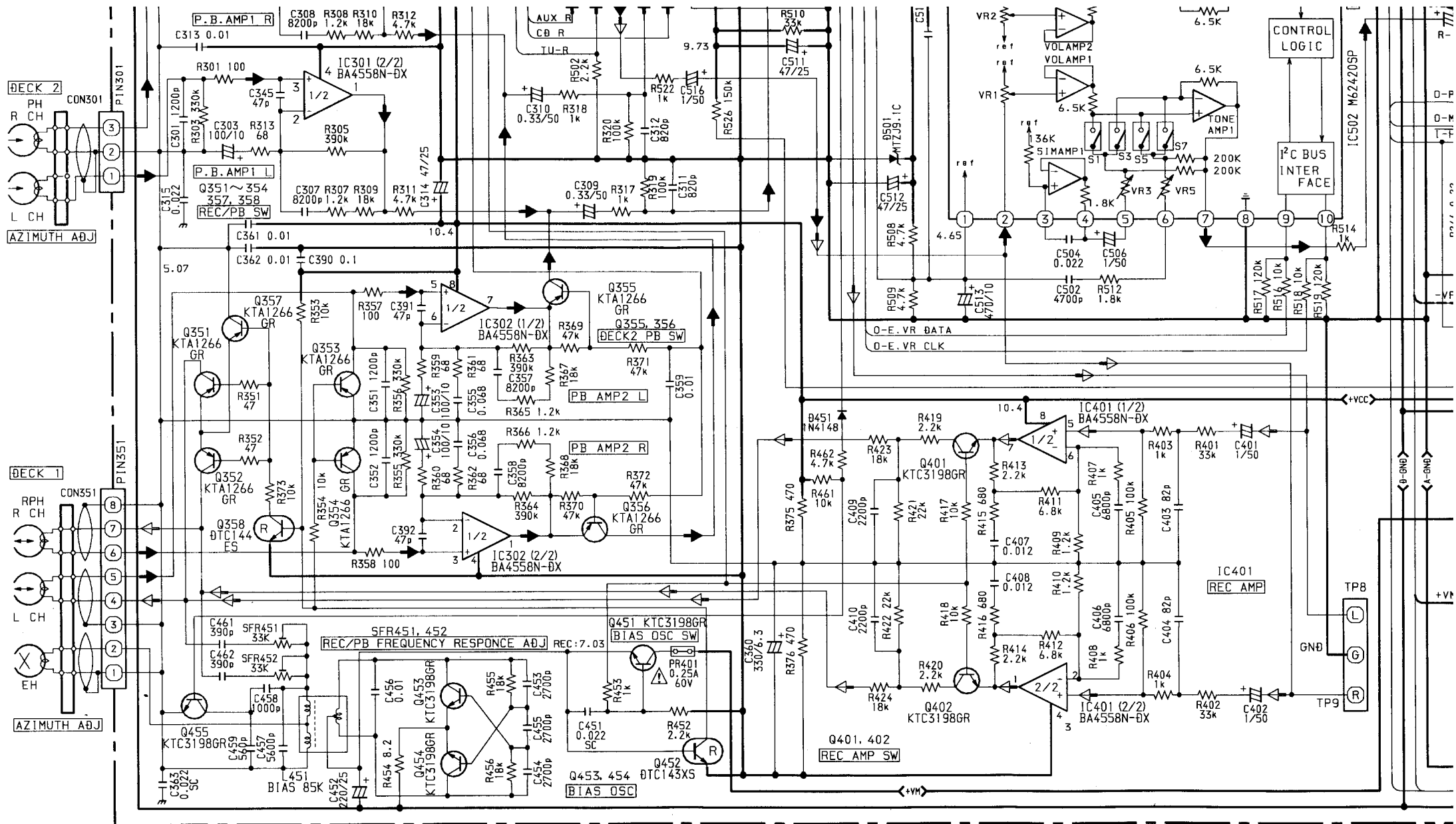

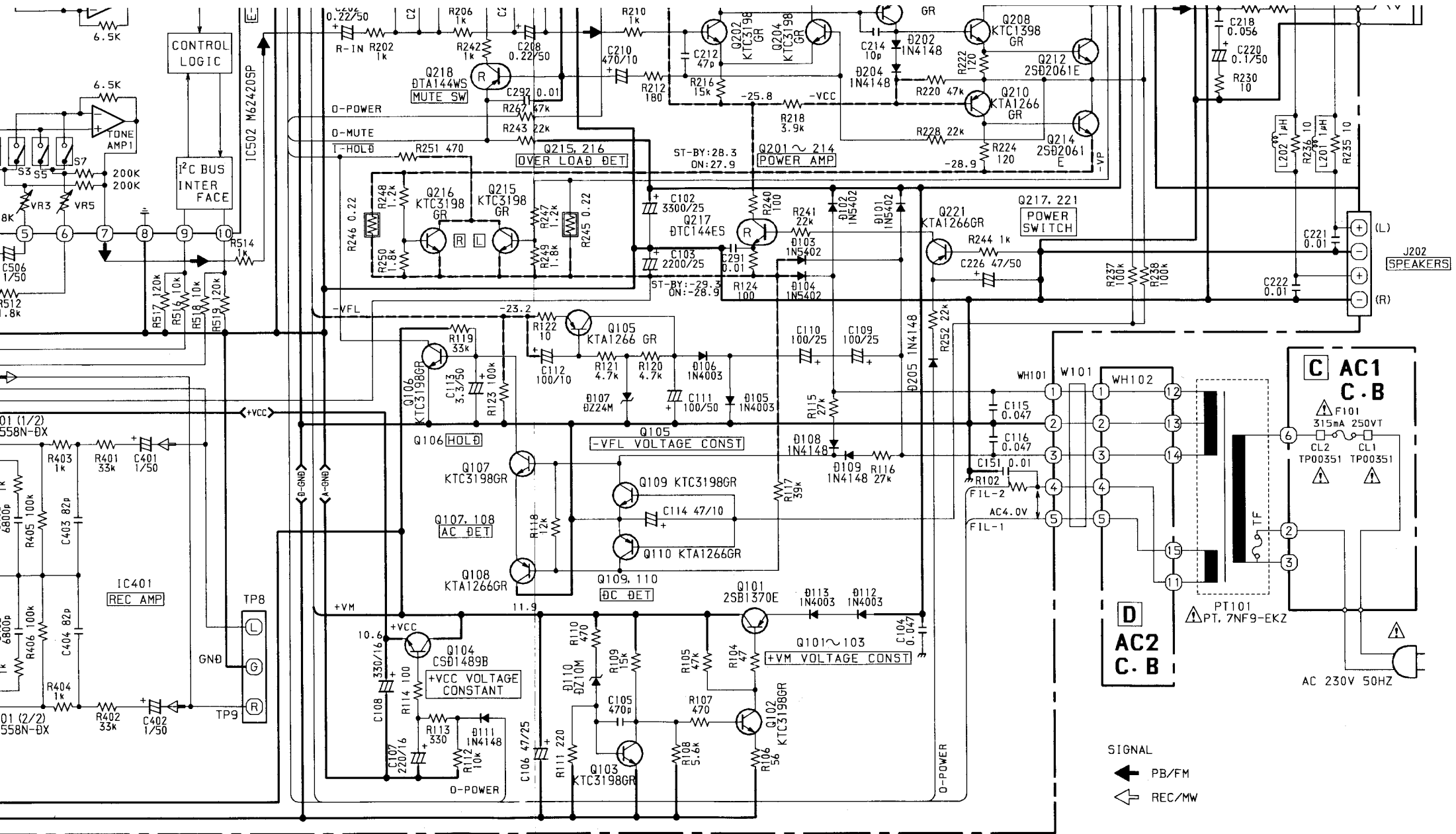

SCHEMATIC DIAGRAM - 6 (MAIN : 10EZ)

FROM [B] FRONT C.B CON101

A MAIN C.B

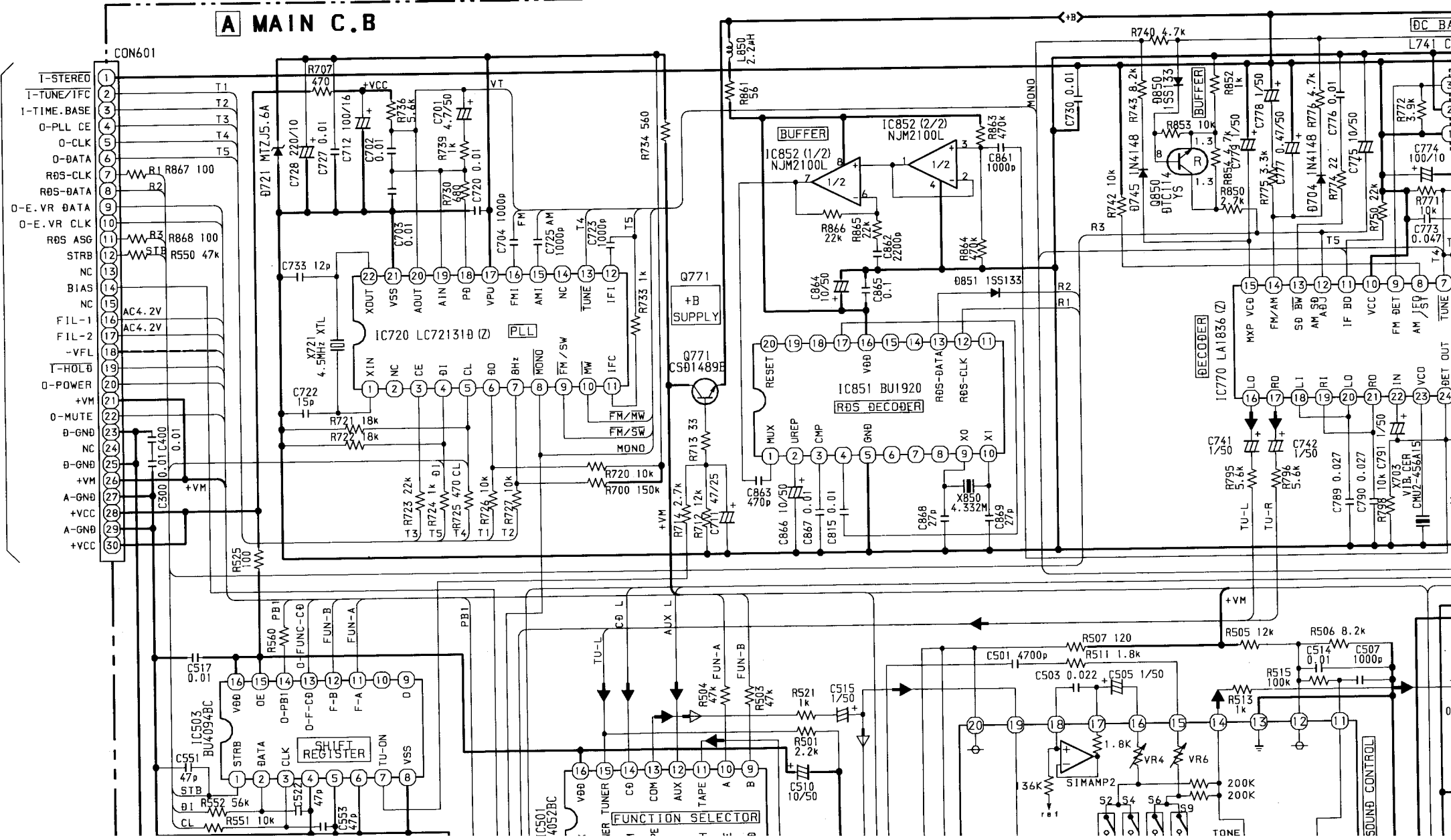

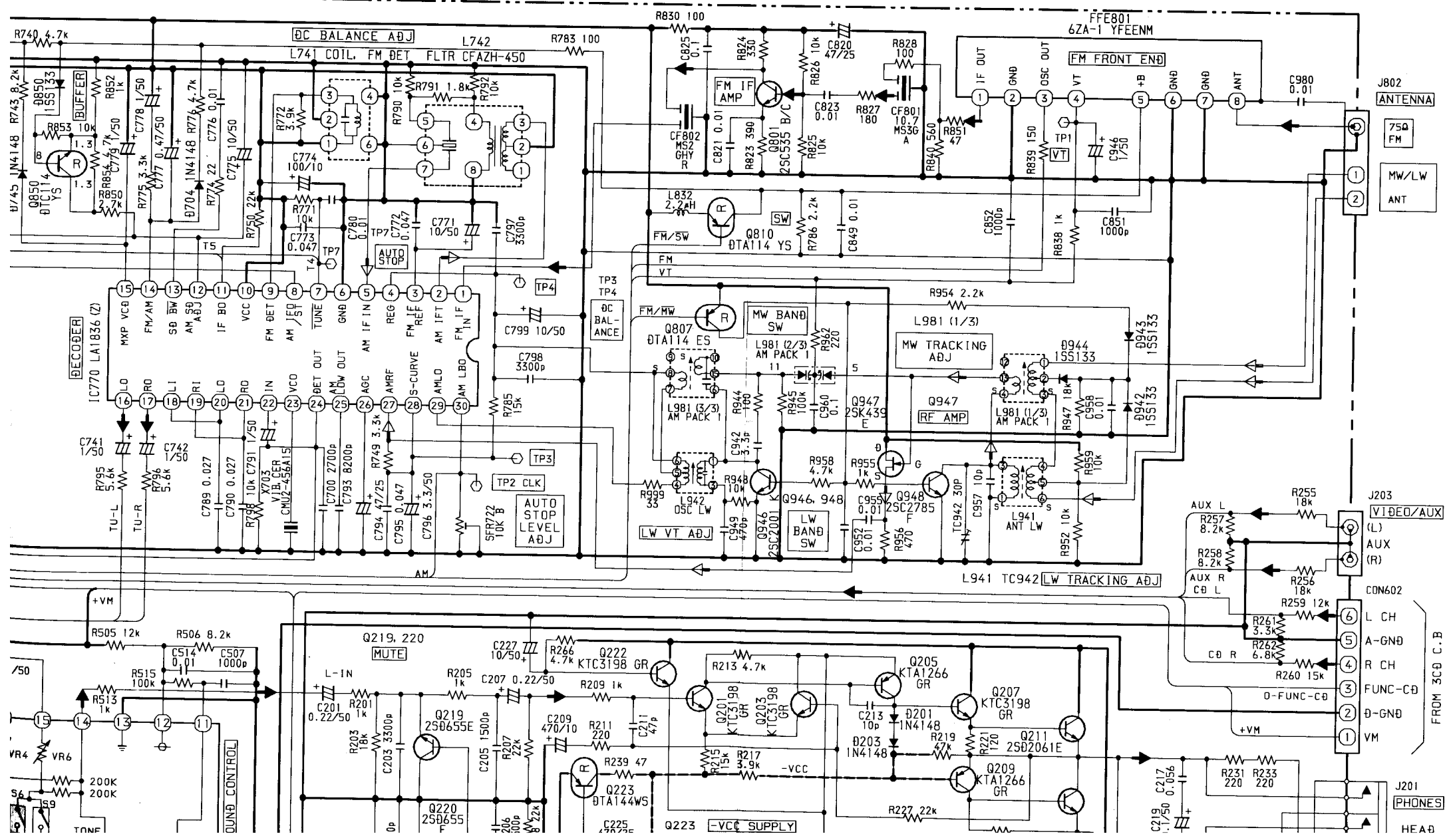

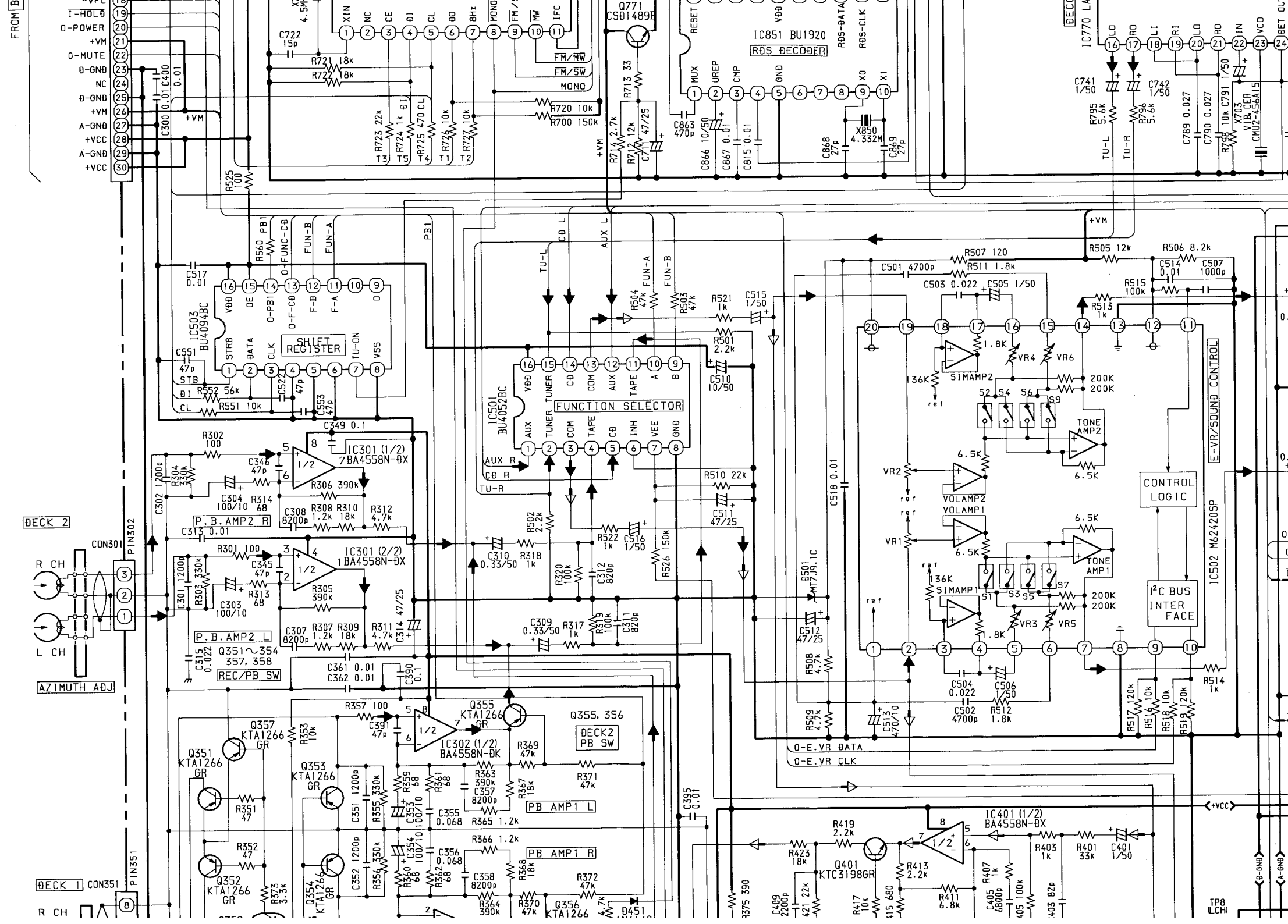

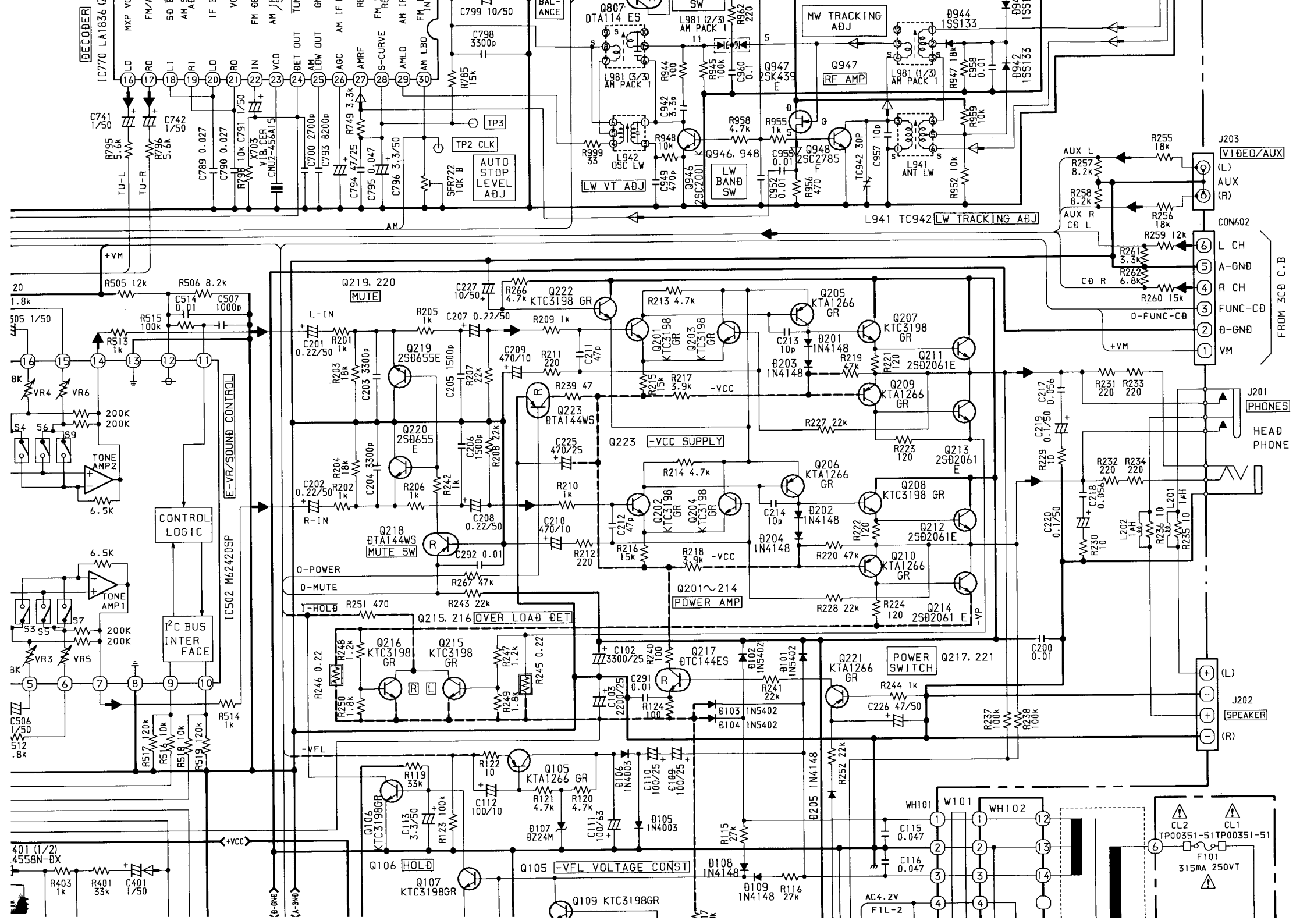

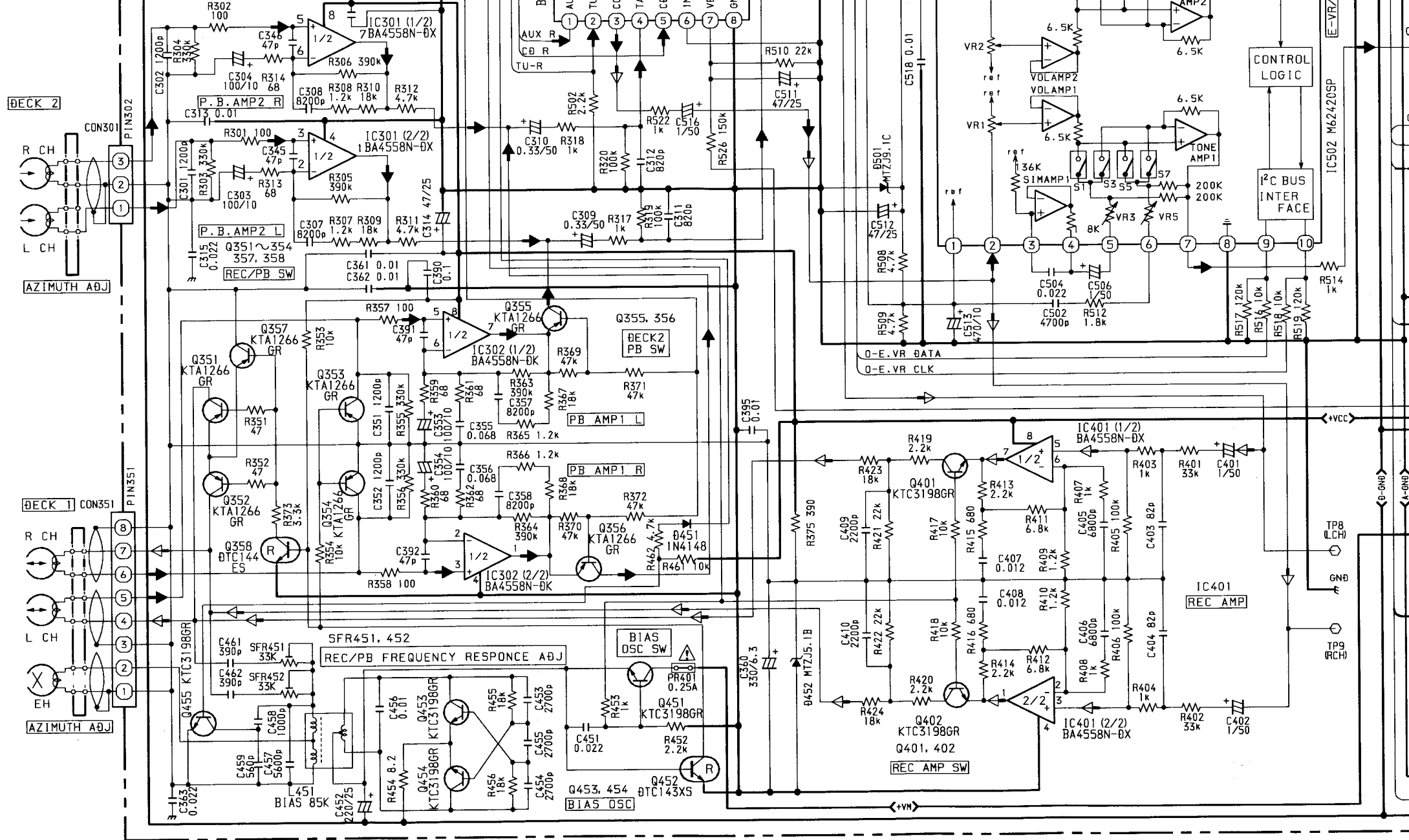

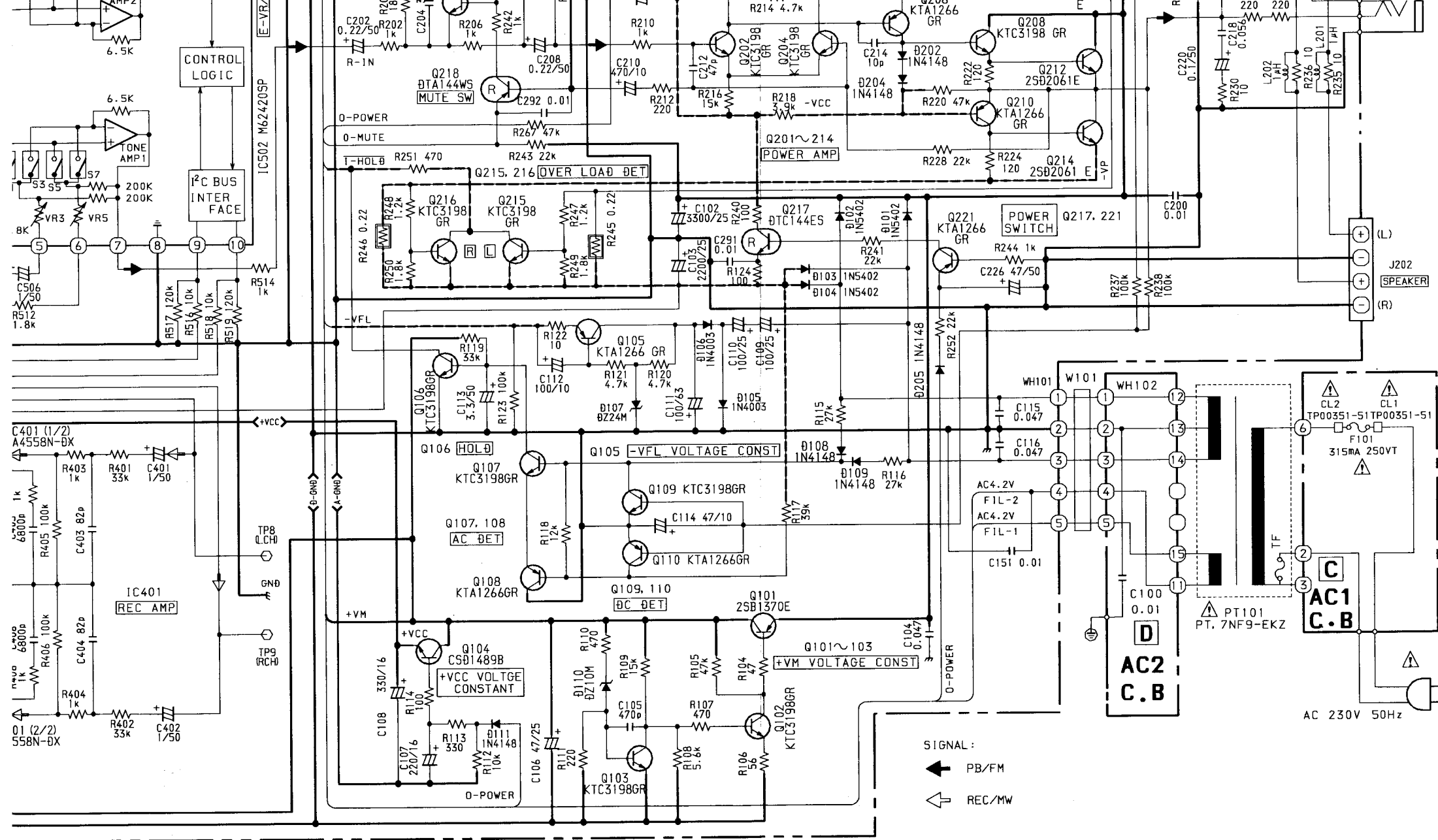

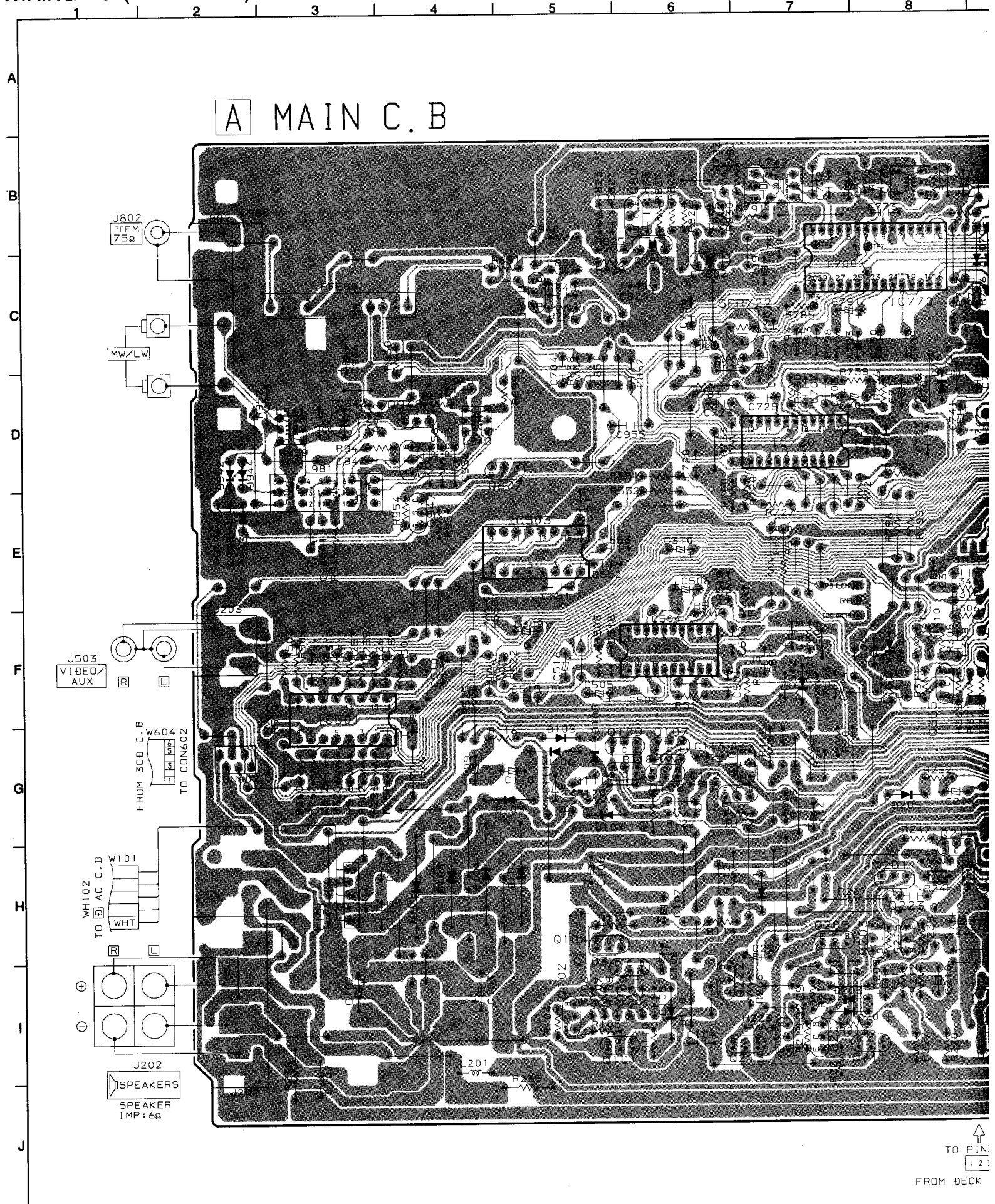

A MAIN C.B

↑
TO PIN
123
↓
FROM DECK

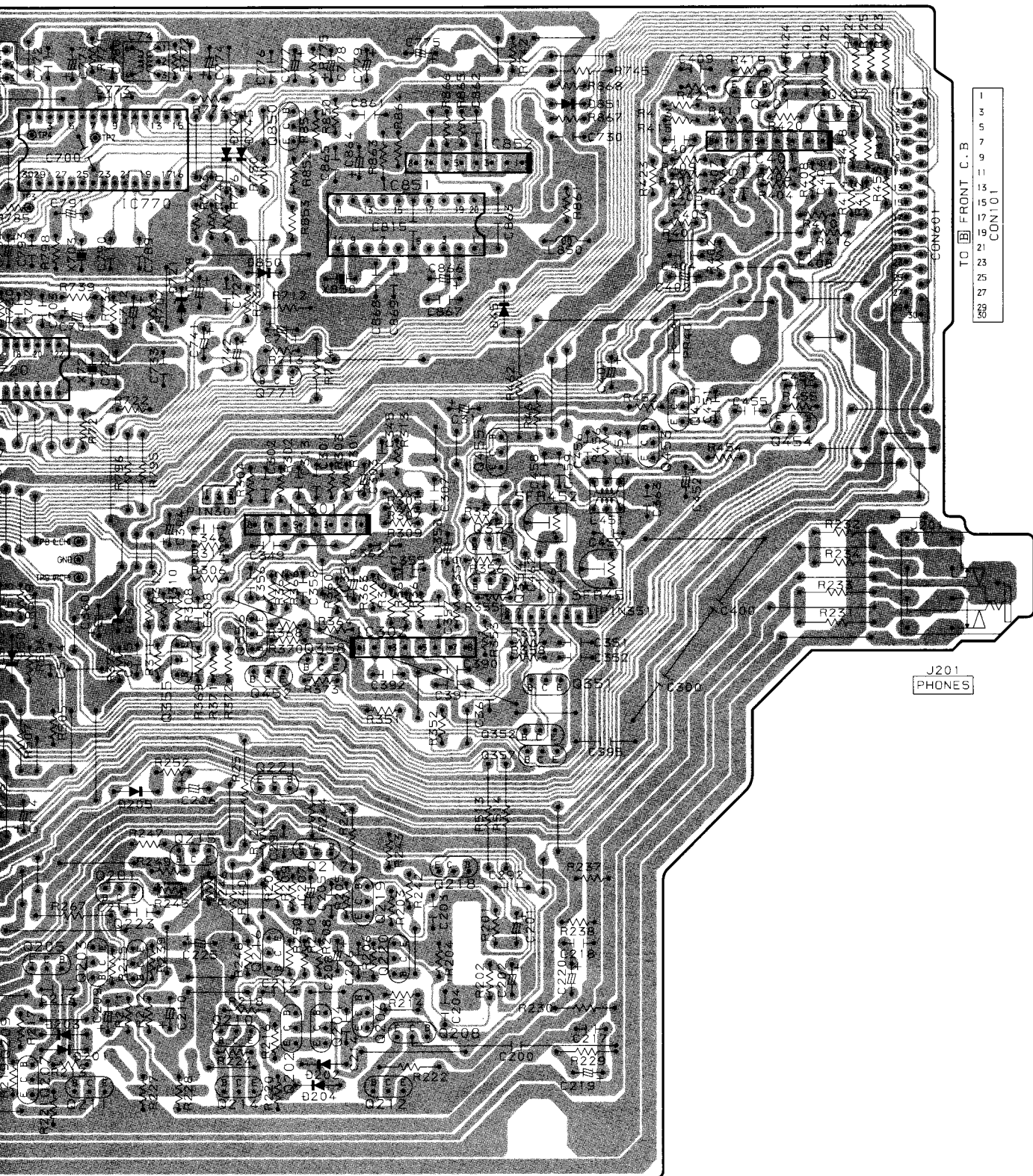

TO FRONT C.B.
CON101
1
3
5
7
9
11
13
15
17
19
21
23
25
27
29

J201
PHONES

↑
TO PIN301
1 2 3
FROM DECK MECHA

↑
TO PIN351:
8 7 5 3 1
FROM DECK MECHA

WIRING - 7 (FRONT : EXCEPT 10EZ)

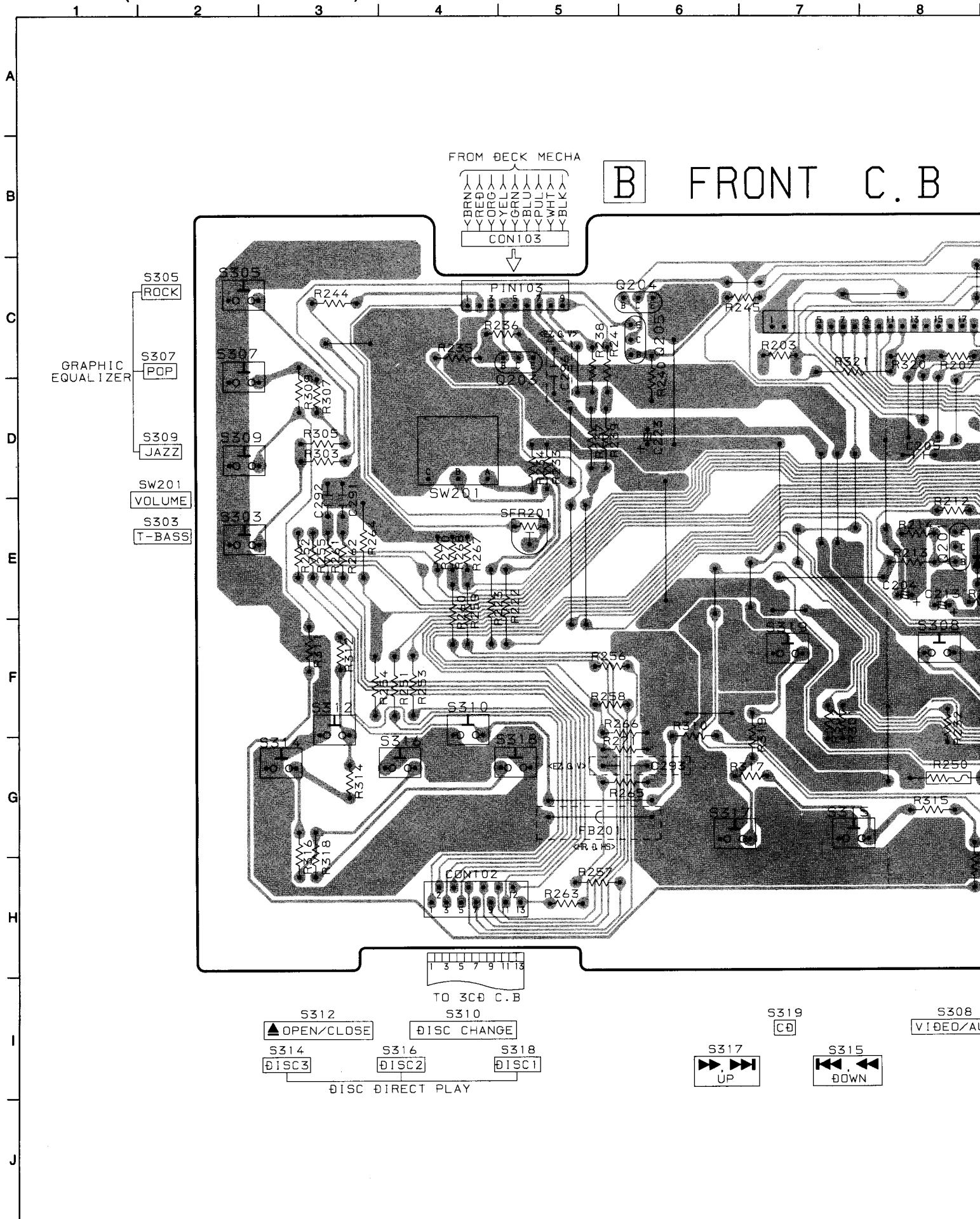

INT C.B

FL301
DISPLAY

S301
POWER

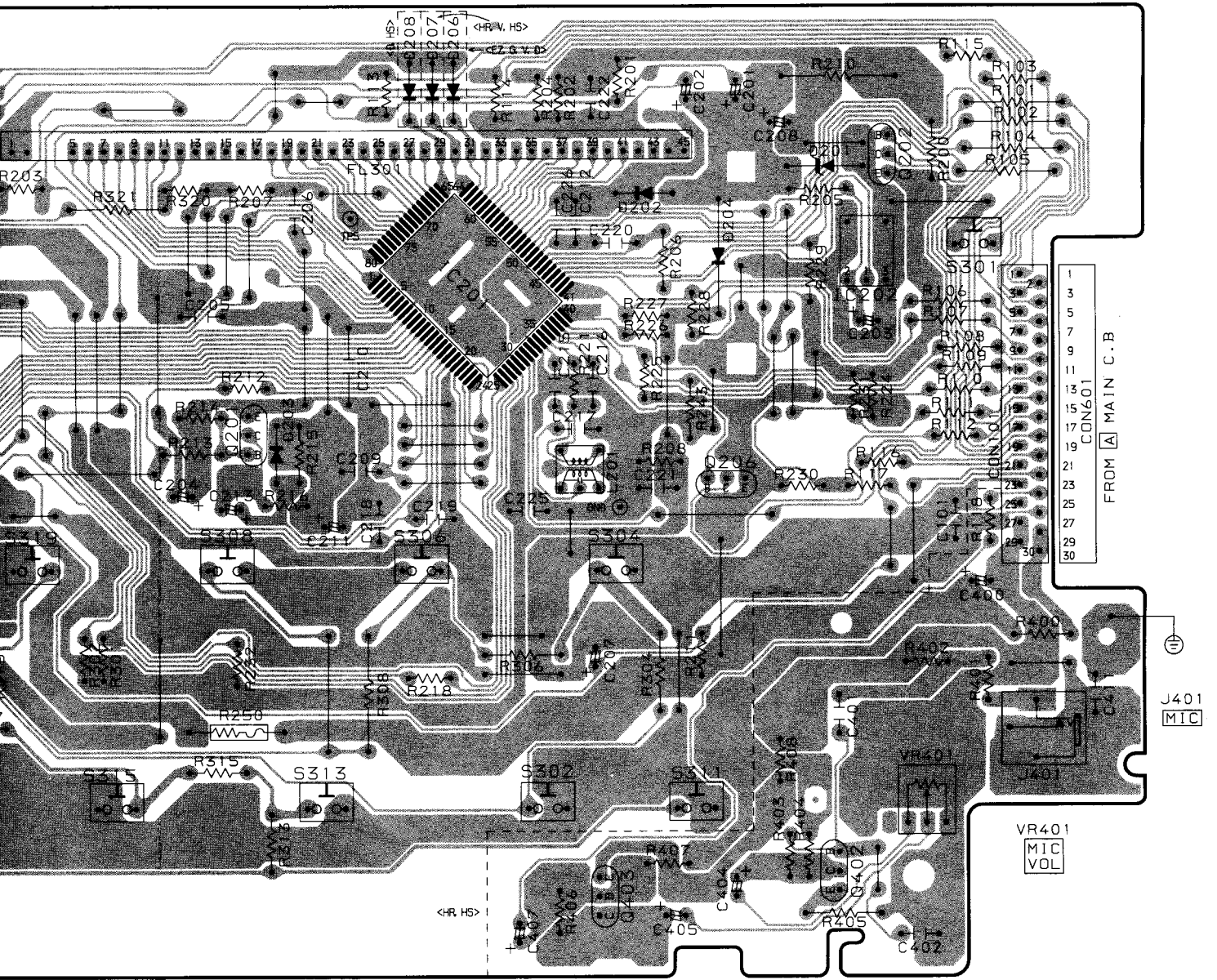

- 1
- 3
- 5
- 7
- 9
- 11
- 13
- 15
- 17
- 19
- 21
- 23
- 25
- 27
- 29
- 30

FROM MAIN C.B



J401
MIC

VR401
MIC
VOL

S319
CD

S308
VIDEO/AUX

S306
TUNER/BAND

S304
TAPE

S315
DOWN

S313
PRESET

S302
CLEAR

S311
SET

SCHEMATIC DIAGRAM - 7 (FRONT : EXCEPT 10EZ)

B FRONT C. B

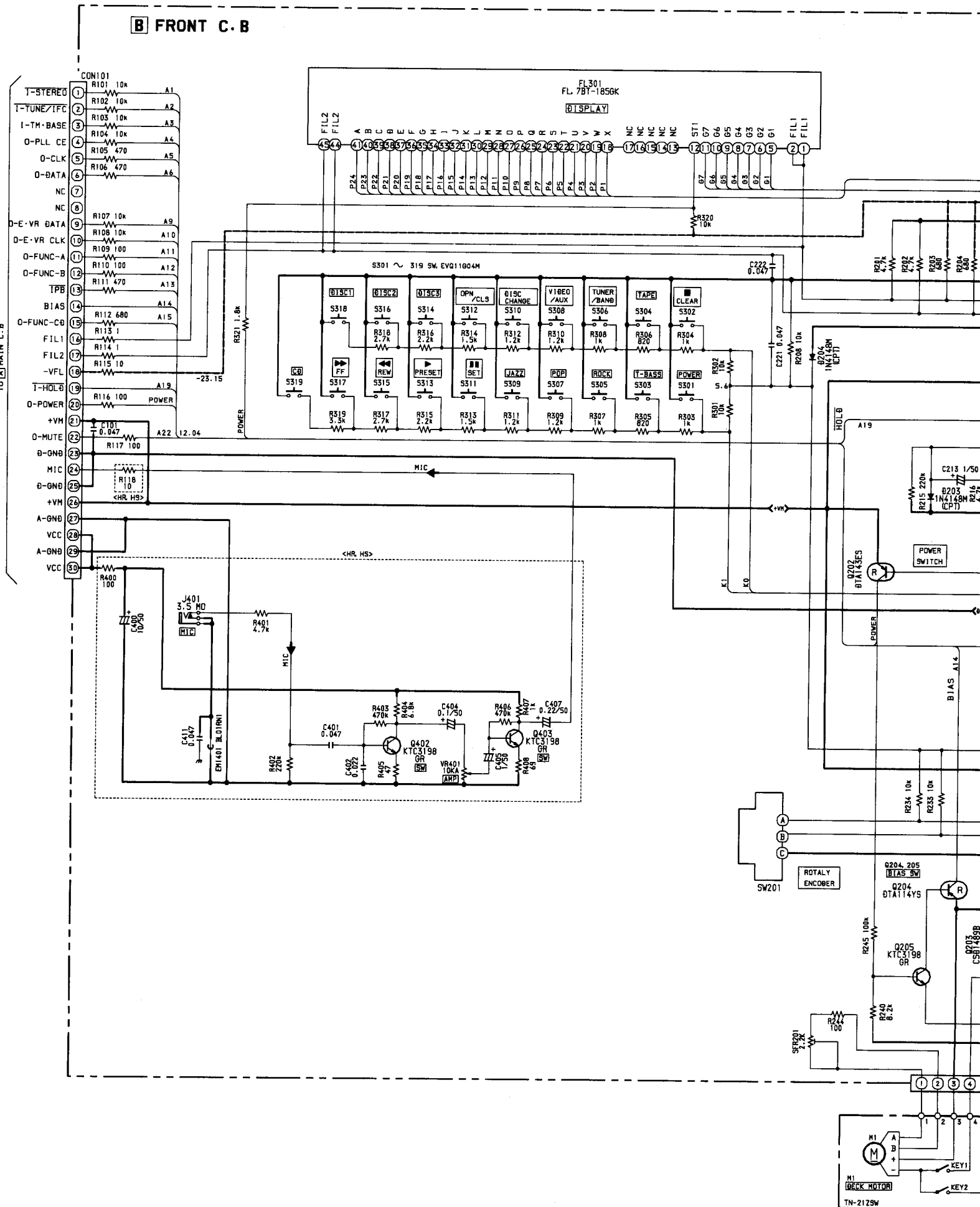

	HR	HS	B	EZ	G	V
Q208	-	0	0	-	-	-
Q207	0	0	-	-	-	0
Q206	-	-	0	0	0	0

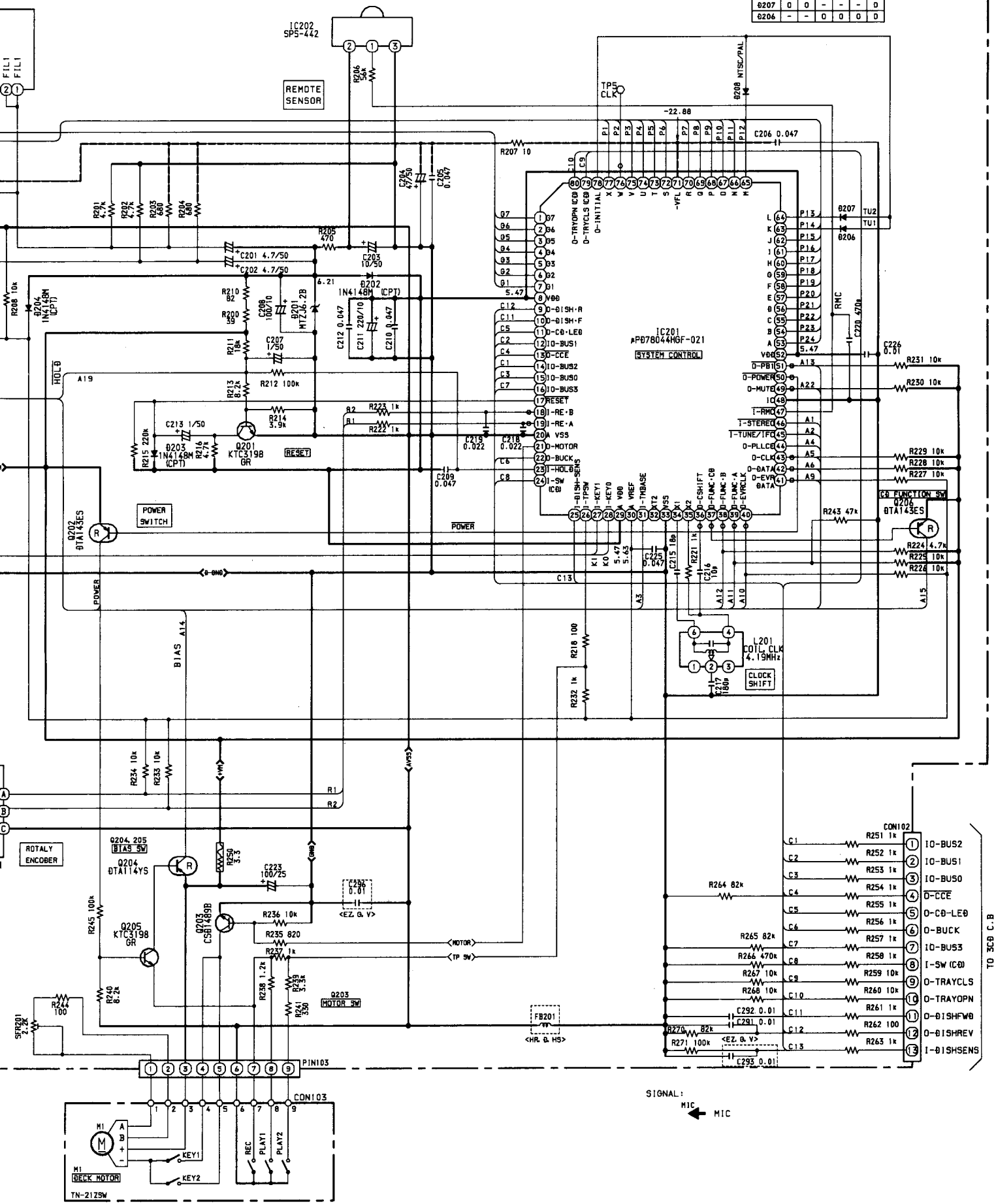

TO 3CB C.B

1 2 3 4 5 6 7 8

A
B
C
D
E
F
G
H
I
J

FROM DECK MECHA

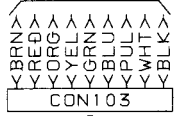

B FRONT C.B

- S305 [ROCK]
- S307 [POP]
- S309 [JAZZ]
- SW201 [VOLUME]
- S303 [T-BASS]

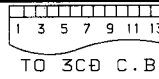
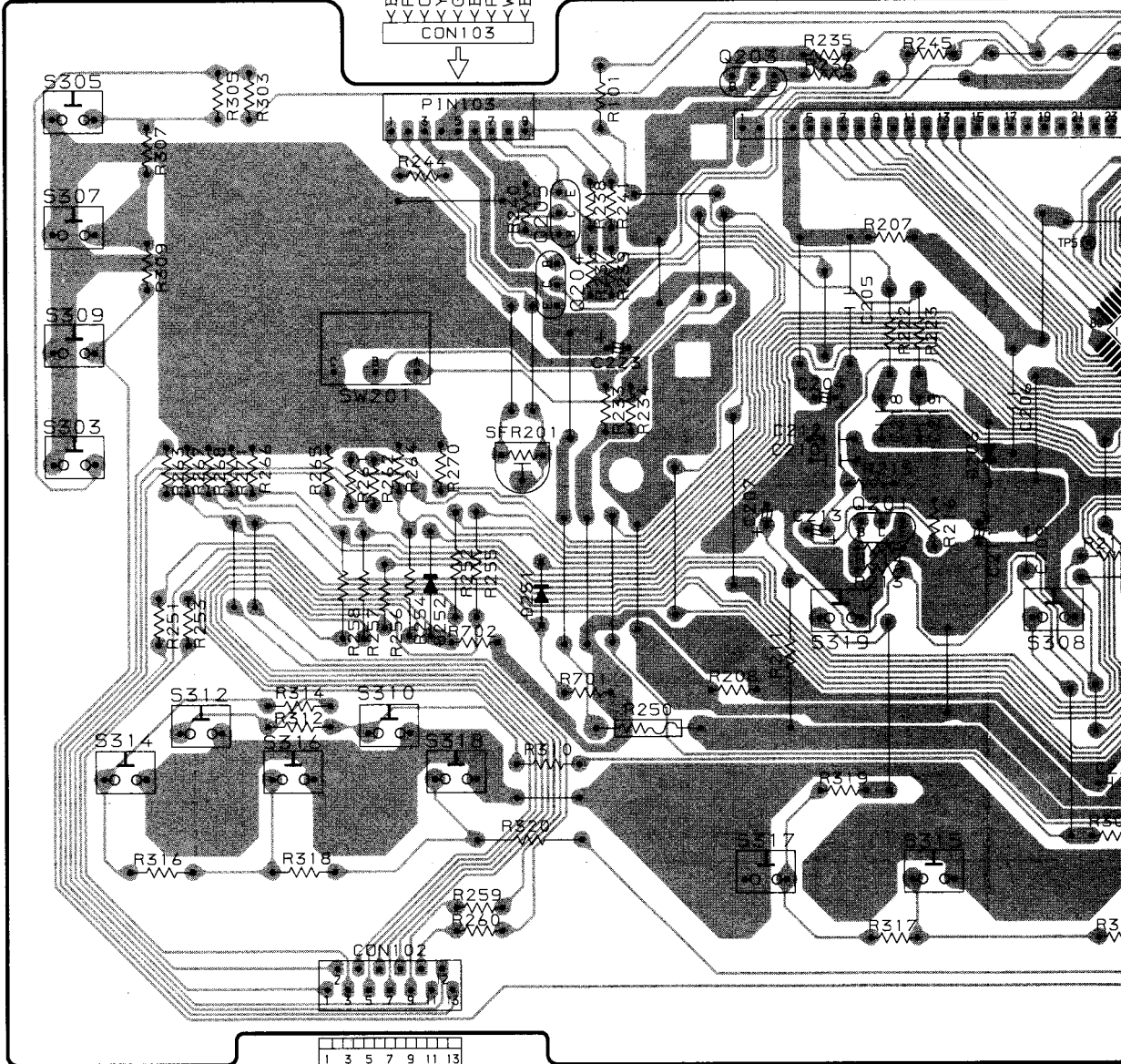

TO 3CD C.B

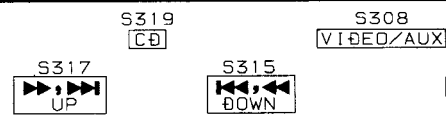
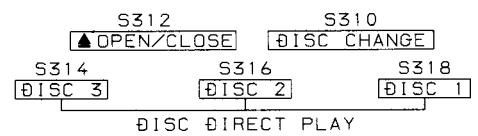

ONT C. B

FL301
DISPLAY

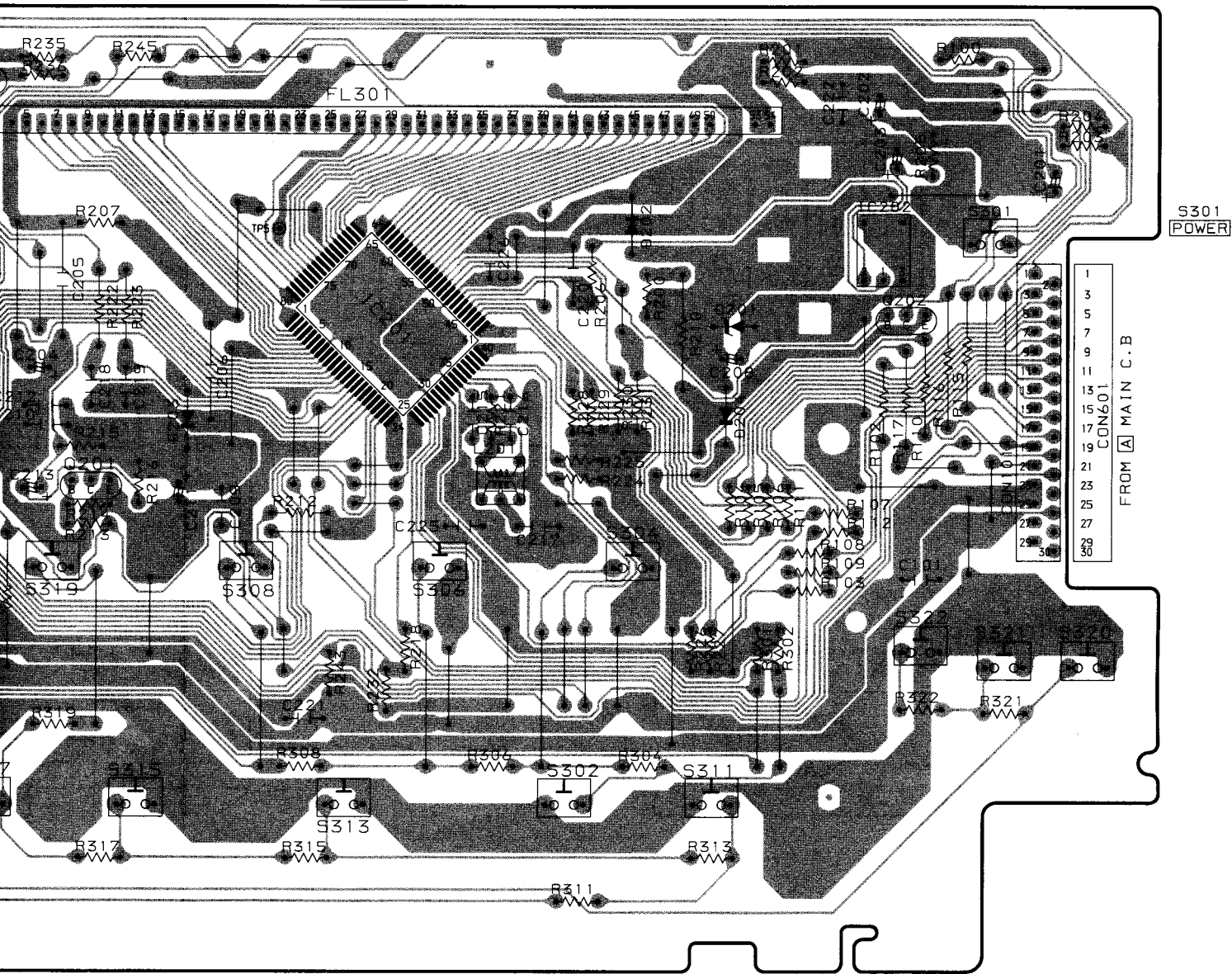

- S319
[CD]
- S315
[DOWN]
- S308
[VIDEO/AUX]
- S313
[PRESET]
- S306
[TUNER/BAND]
- S302
[CLEAR]
- S304
[TAPE]
- S311
[SET]
- S322
[AG]
- S321
[PTY]
- S320
[RDS]

SCHEMATIC DIAGRAM - 8 (FRONT : 10EZ)

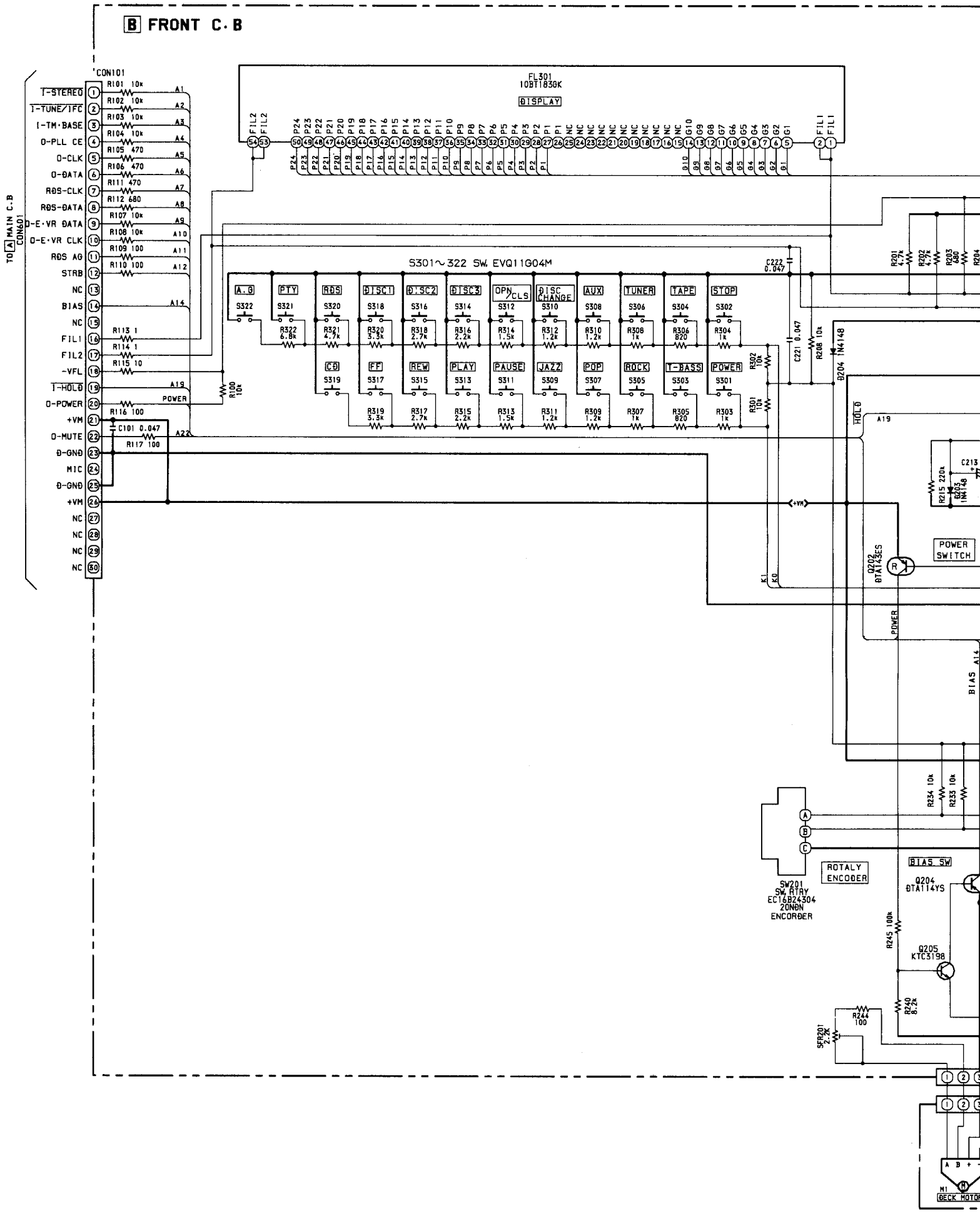

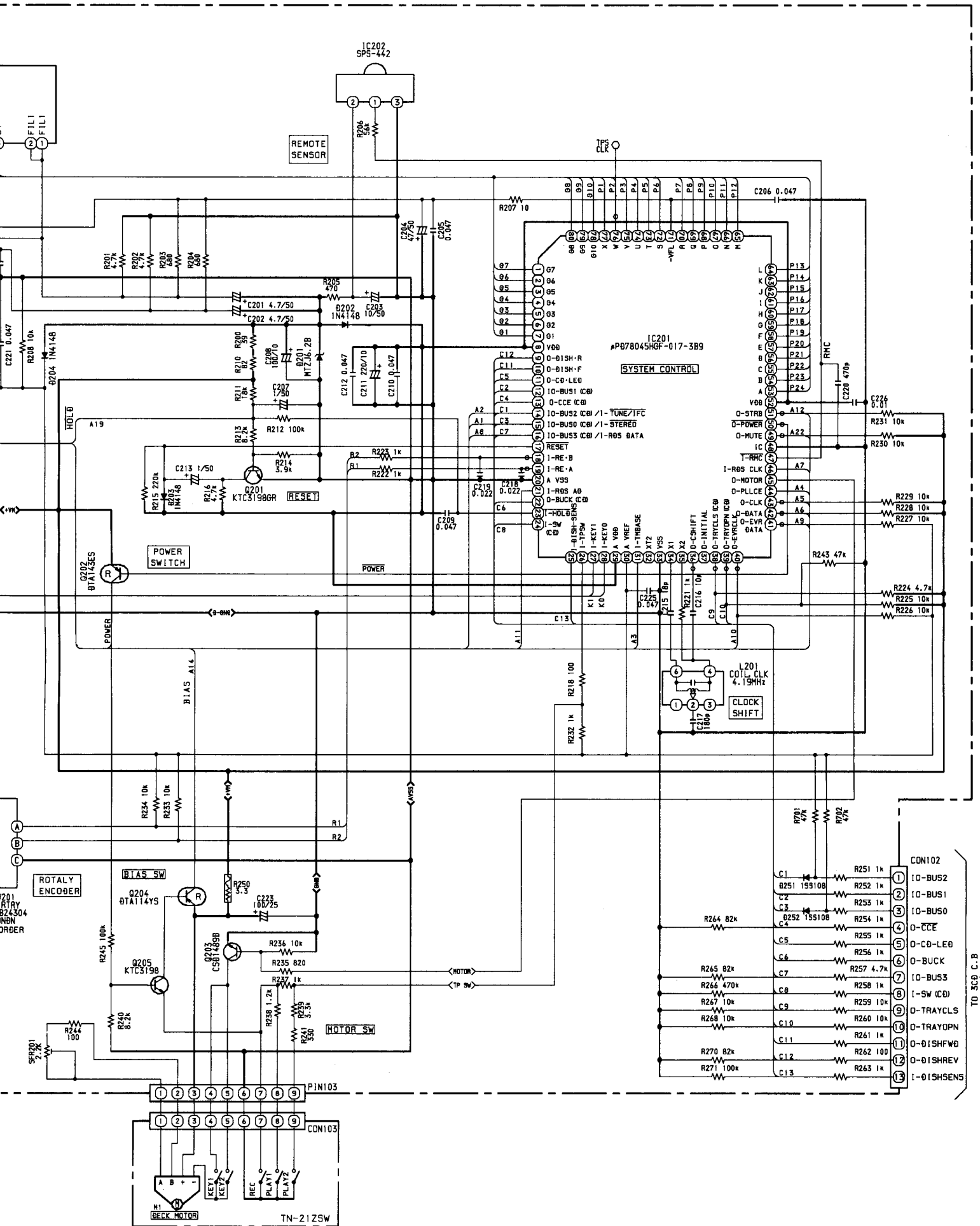

WIRING - 9 (AC)

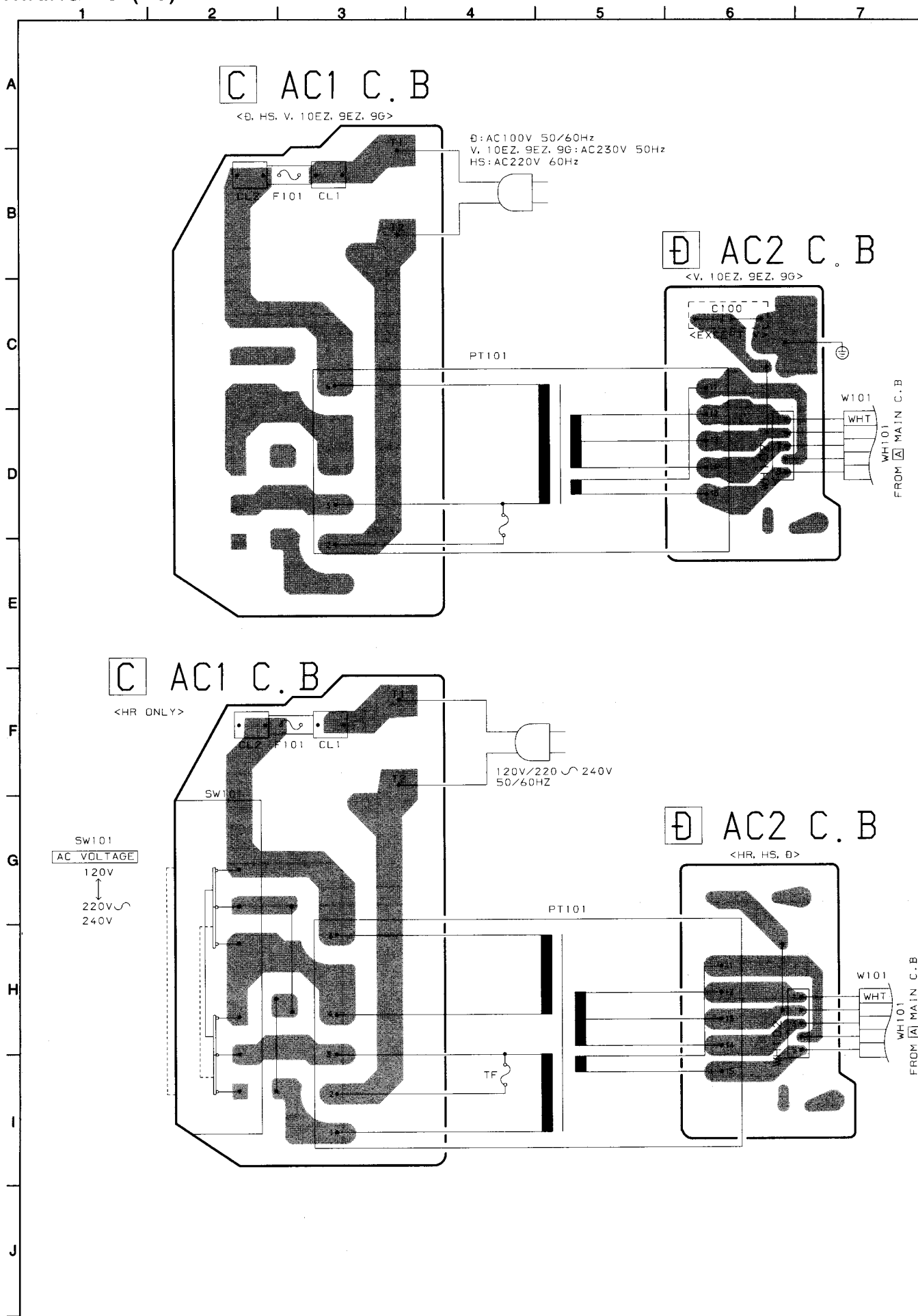

1
2
3
4
5
6
7

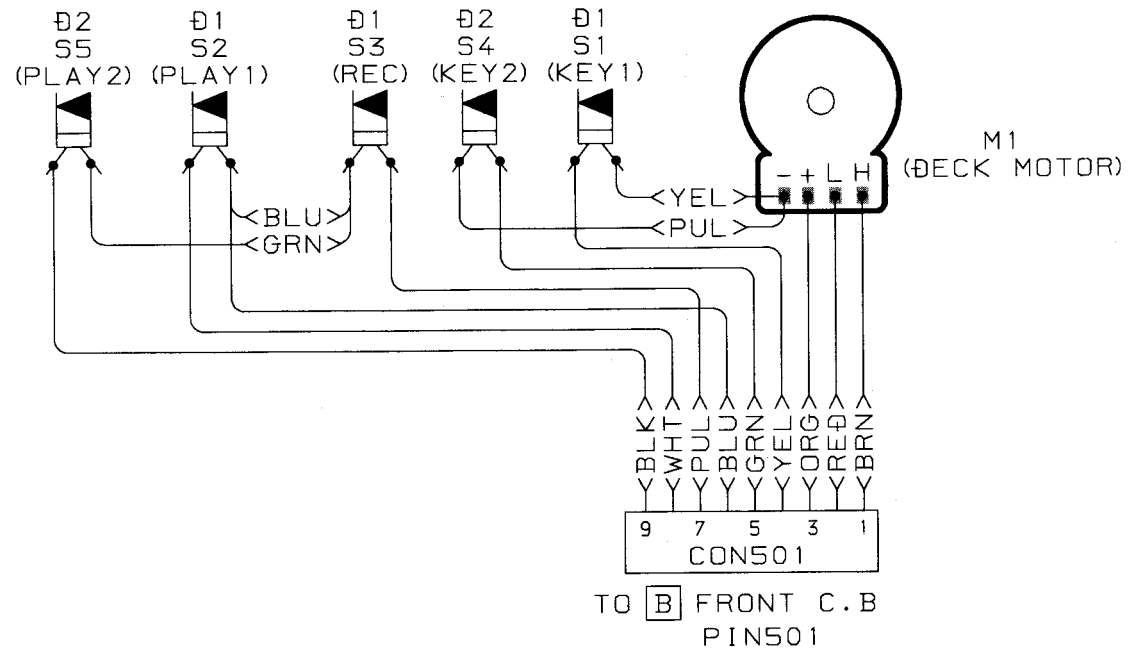
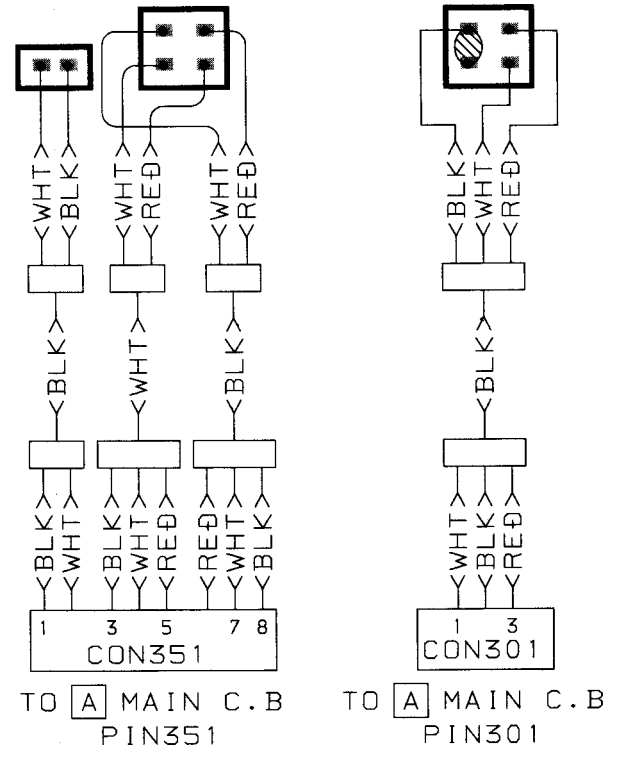
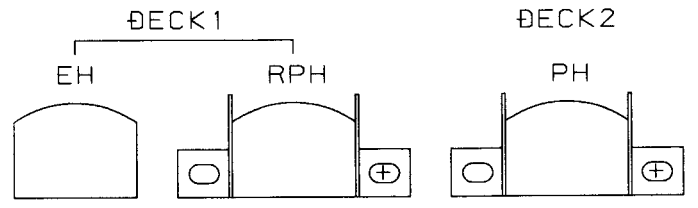

IC BLOCK DIAGRAM - 2

IC, TA8124P

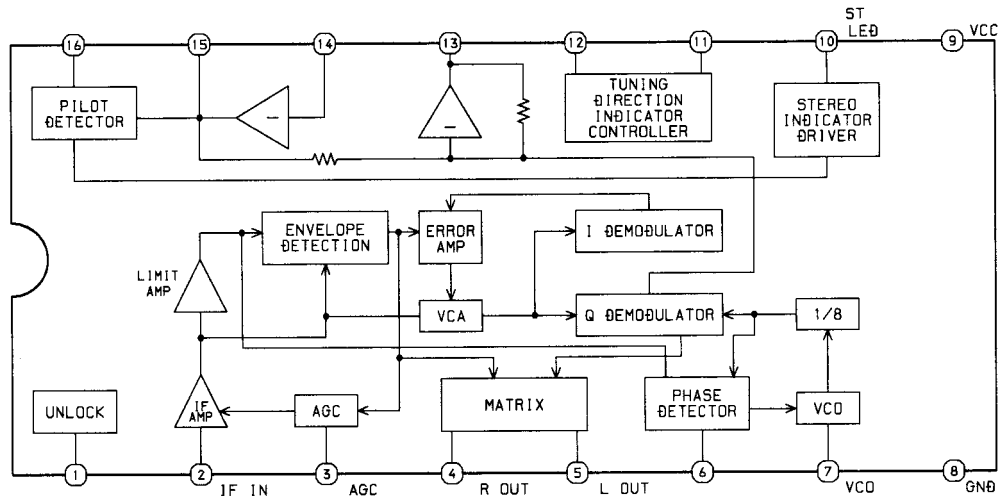

IC, LA1836

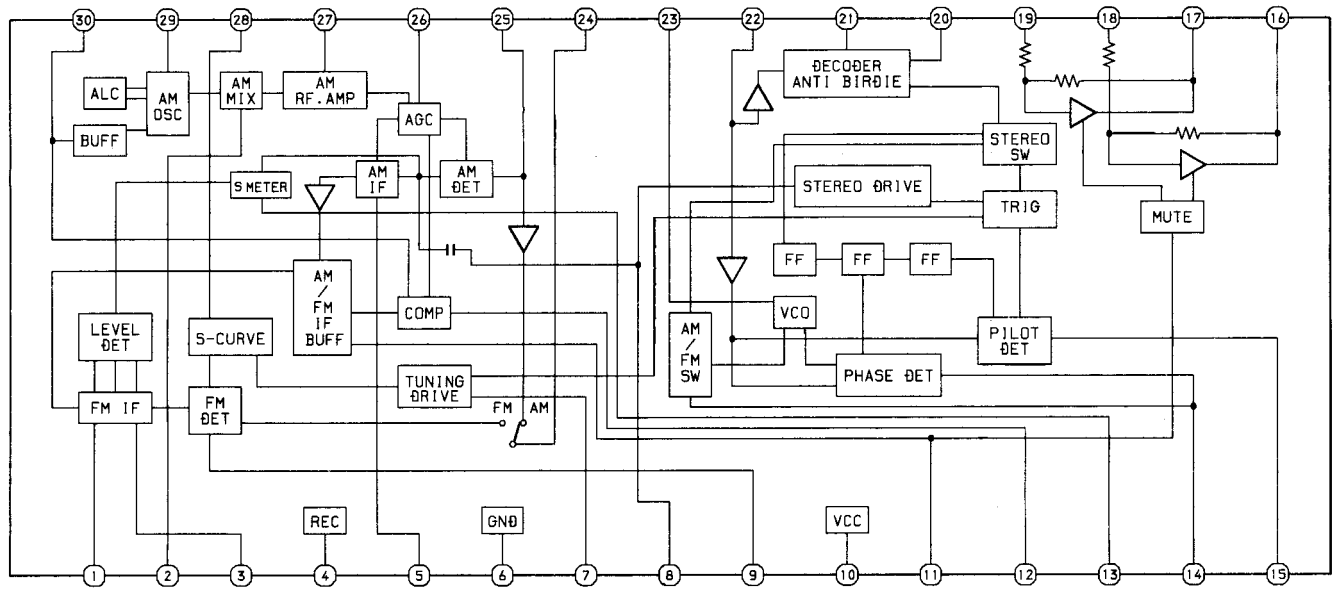

IC, BU4094

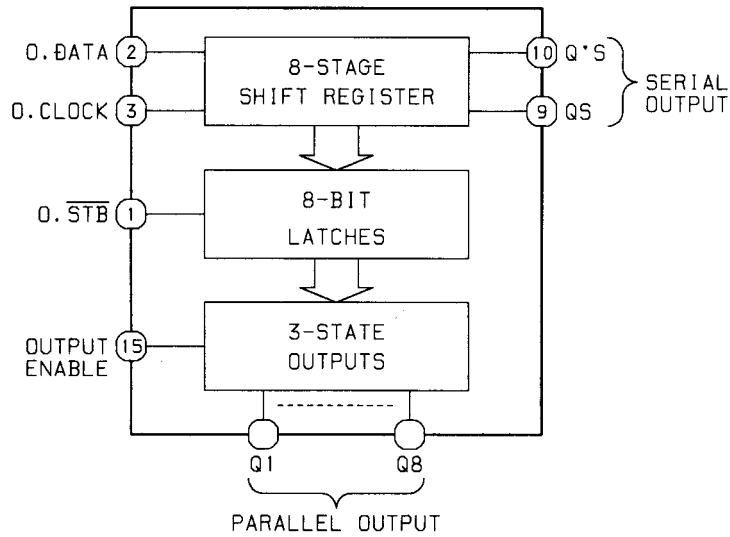

Q1: 0. DOLBY ON Q5: 0. PLAY
 Q2: 0. DOLBY C Q6: 0. PB2
 Q3: 0. EXT. REC Q7: 0. LEØ
 Q4: 0. INT. REC Q8: 0. RMT

TRUTH TABLE

CLOCK	OUTPUT ENABLE	STROBE	DATA	PARALLEL OUTPUTS		SERIAL OUTPUTS	
				Q1	Qn	QS	Q'S
\bar{f}	L	x	x	Z	Z	Q7	NO CHG.
\bar{f}	L	x	x	Z	Z	NO CHG.	QS
\bar{f}	H	L	x	NO CHG.	NO CHG.	Q7	NO CHG.
\bar{f}	H	H	L	L	Qn-1	Q7	NO CHG.
\bar{f}	H	H	H	H	Qn-1	Q7	NO CHG.
\bar{f}	H	x	x	NO CHG.	NO CHG.	NO CHG.	QS

Z = HIGH IMPEDANCE
 x = DON'T CARE

IC, LA1836

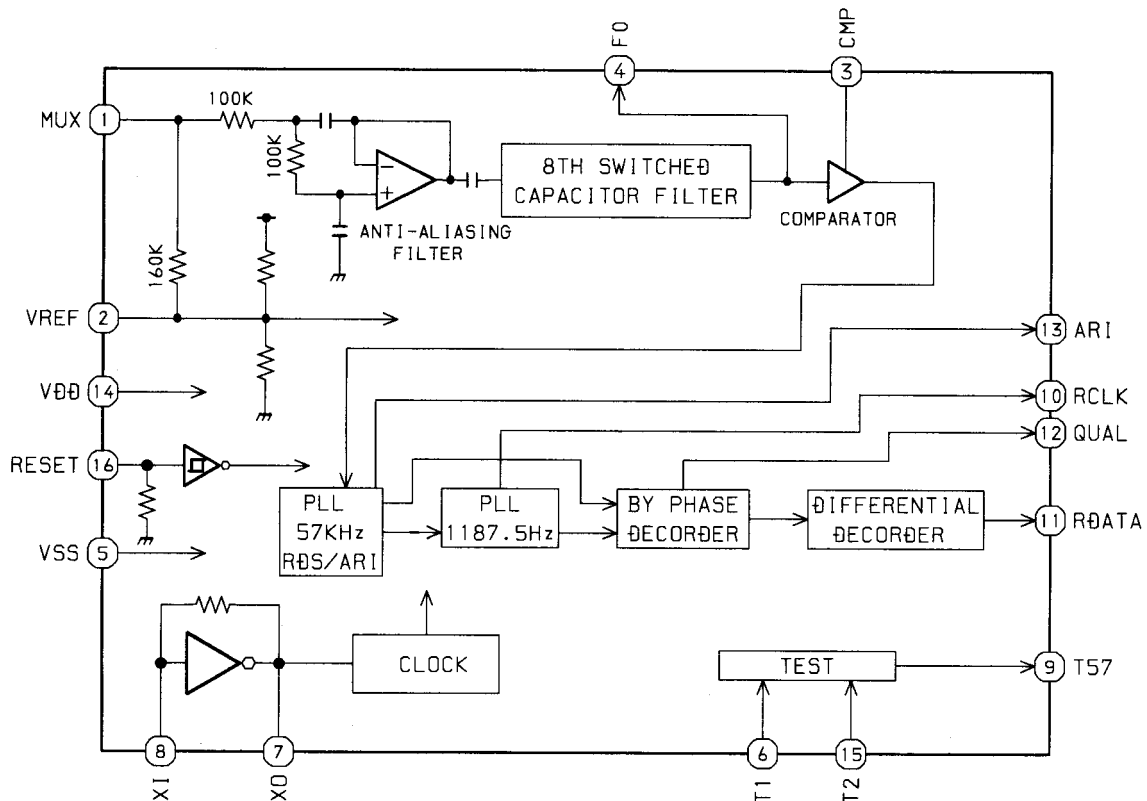

FL GRID ASSIGNMENT & ANODE CONNECTION (EXCEPT 10EZ)

GRID ASSIGNMENT

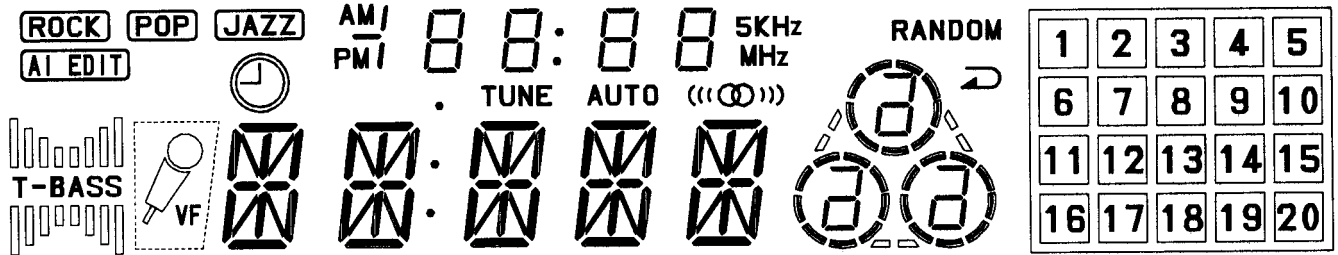

SEGMENT DESIGNATION

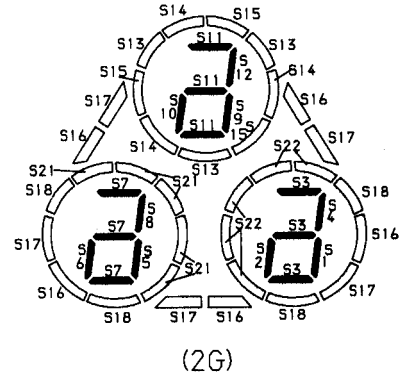
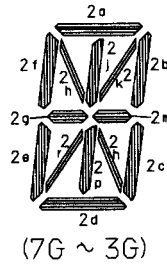
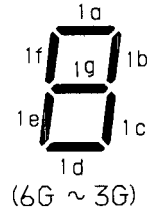

ANODE CONNECTION

	7G	6G	5G	4G	3G	2G	1G
P1	2d	2d	2d	2d	2d	S1	20
P2	2j, 2p	2j, 2p	2j, 2p	2j, 2p	2j, 2p	S2	19
P3	2n	2n	2n	2n	2n	S3	18
P4	2r	2r	2r	2r	2r	S4	17
P5	2c	2c	2c	2c	2c	S5	16
P6	2e	2e	2e	2e	2e	S6	15
P7	2m	2m	2m	2m	2m	S7	14
P8	2g	2g	2g	2g	2g	S8	13
P9	2f	2f	2f	2f	2f	S9	12
P10	2b	2b	2b	2b	2b	S10	11
P11	2k	2k	2k	2k	2k	S11	10
P12	2h	2h	2h	2h	2h	S12	9
P13	2a	2a	2a	2a	2a	S13	8
P14	VF	.	TUNE	AUTO	((OO))	S14	7
P15	T-BASS	o	o (F)	—	MHz	S15	6
P16	AI EDIT	—	o (U)	—	KHz	S16	5
P17	clock	—	—	—	5	S17	4
P18	PM	1d	1d	1d	1d	S18	3
P19	—	1e	1e	1e	1e	—	2
P20		1c	1c	1c	1c	—	1
P21	AM	1g	1g	1g	1g	S21	—
P22	(JAZZ)	1f	1f	1f	1f	S22	—
P23	(POP)	1b	1b	1b	1b	random	—
P24	(ROCK)	1a	1a	1a	1a	RANDOM	—
P25	—	—	—	—	—	—	grid

FL GRID ASSIGNMENT & ANODE CONNECTION (10EZ)

GRID ASSISNMENT

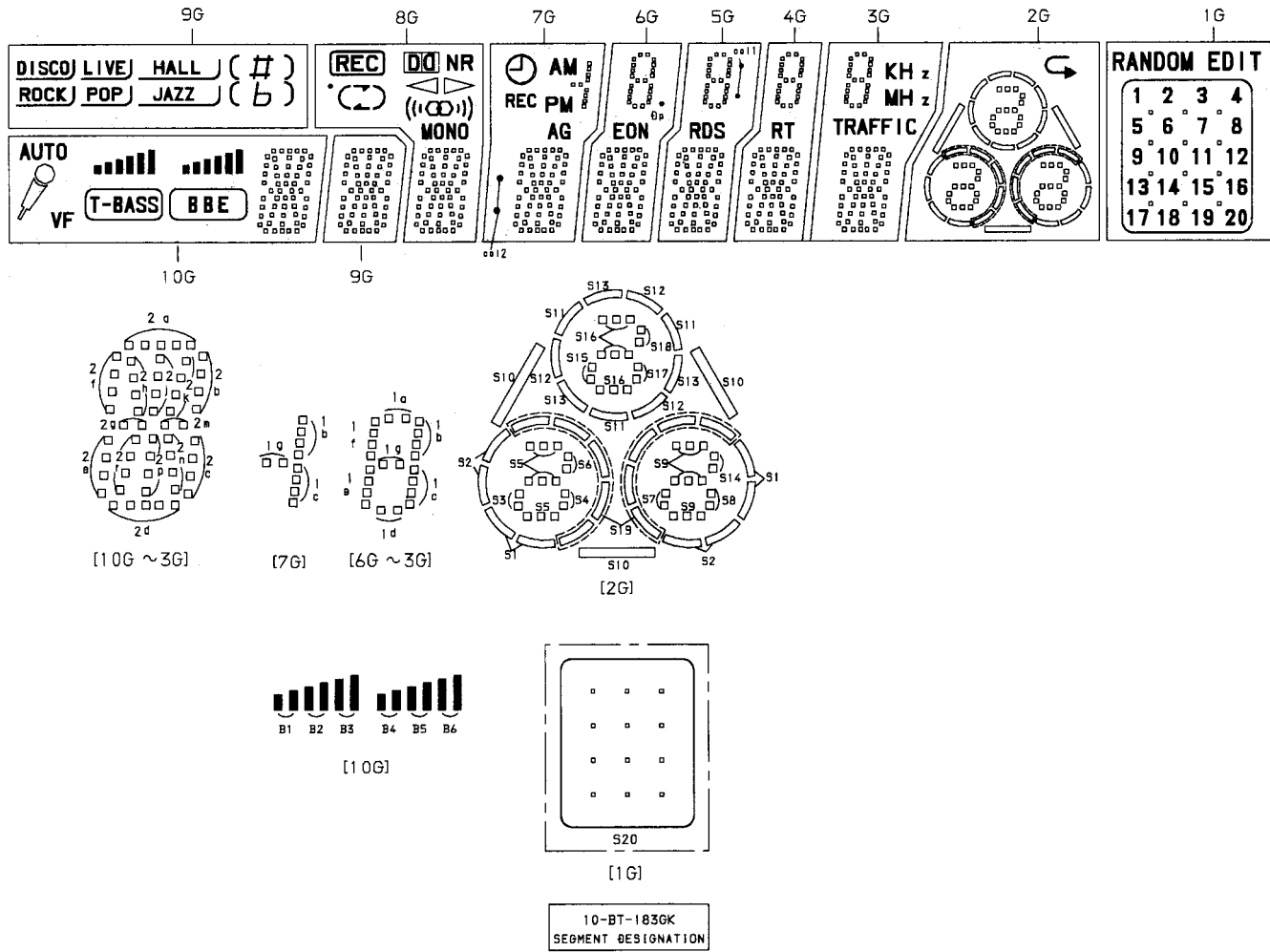

ANODE CONNECTION

	10G	9G	8G	7G	6G	5G	4G	3G	2G	1G
P1	2d	2d	2d	2d	2d	2d	2d	2d	S1	20
P2	2h	2h	2h	2h	2h	2h	2h	2h	S2	19
P3	2p	2p	2p	2p	2p	2p	2p	2p	S3	18
P4	2r	2r	2r	2r	2r	2r	2r	2r	S4	17
P5	2e	2e	2e	2e	2e	2e	2e	2e	S5	16
P6	2c	2c	2c	2c	2c	2c	2c	2c	S6	15
P7	2g	2g	2g	2g	2g	2g	2g	2g	S7	14
P8	2m	2m	2m	2m	2m	2m	2m	2m	S8	13
P9	2f	2f	2f	2f	2f	2f	2f	2f	S9	12
P10	2b	2b	2b	2b	2b	2b	2b	2b	S10	11
P11	2k	2k	2k	2k	2k	2k	2k	2k	S11	10
P12	2j	2j	2j	2j	2j	2j	2j	2j	S12	9
P13	2h	2h	2h	2h	2h	2h	2h	2h	S13	8
P14	2a	2a	2a	2a	2a	2a	2a	2a	S14	7
P15	BBE	(DISCO)	MONO	AG	EON	RDS	RT	TRAFFIC	S15	6
P16	T-BASS	(LIVE)	(NR)	col	—	co (LOWER)	—	MHz	S16	5
P17	ϕ_{VF}	(HALL)	\triangleleft	REC	$\oplus p$	co (UPPER)	—	KHz	S17	4
P18	AUTO	(ROCK)	\triangleleft	\oplus	1d	1d	1d	1d	S18	3
P19	B1	(POP)	\circ	PM	1e	1e	1e	1e	S19	2
P20	B2	(JAZZ)	\circ	AM	1c	1c	1c	1c	\curvearrowright	1
P21	B3	([#])	\sim	1g	1g	1g	1g	1g	—	RANDOM
P22	B4	([b])	\sim	1a, 1c	1f	1f	1f	1f	—	EDIT
P23	B5	DISCO LIVE HALL	REC	—	1b	1b	1b	1b	—	S20
P24	B6	ROCK POP JAZZ	NR	—	1a	1a	1a	1a	—	—
P25	—	# b	—	—	—	—	—	—	—	—

IC DESCRIPTION (D)

IC, μ PD78044HGF-021-3B9

端子番号	端子名称	I/O	機能説明															
1~7	G7~G1	O	FL グリッド出力															
8	VDD	-	電源端子															
9	O-DISH-R	O	CD ターンテーブル逆回転出力															
10	O-DISH-F	O	CD ターンテーブル正回転出力															
11	O-CD-LED	O	CD フラッシュウインドウ LED ON/OFF 出力															
12	O-CDCE(CD)	O	CDCE 出力															
13	I-WRQ(CD)	I	WRQ 入力															
14	O-CLK(CD)	O	CLK 出力															
15	O-DATA(CD)	O	データ出力															
16	I-SUBQ(CD)	I	SUB-Q 入力															
17	RESET	I	リセット入力															
18	I-RE-B	I	ロータリーエンコーダー A 入力															
19	I-RE-A	I	ロータリーエンコーダー B 入力															
20	A VSS	-	GND															
21	O-MOTOR	O	デッキモータ 入力															
22	NC	-	未使用															
23	I-HOLD	I	電源不良検出 入力 "L" クロック停止、メモリー保持															
24	I-CDSW	I	CD ターンテーブルフォトセンサー A/D コンバーター入力															
25	I-DISH	I	CD メカスイッチ A/D コンバーター入力															
26	I-TPSW	I	デッキメカスイッチ A/D コンバーター入力															
27,28	I-KEY0,1	I	キー入力 (AD)															
29	A VDD	-	電源端子															
30	A VREF	-	リファレンス電圧 (+5V)															
31	I-TMBASE	I	タイマー時計用リファレンスクロック入力															
32	NC	-	未使用															
33	VSS	-	GND															
34,35	X1,X2	I/O	511.47Hz 発振子回路															
36	O-CSHIFT	O	マイコンクロックシフト出力															
37	O-FUNC-CD	O	CD 用電源、 $\overline{\text{ON}}$ /OFF 出力															
38	O-FUNC-B	O	ファンクションスイッチ出力															
39	O-FUNC-A		<table border="1"> <thead> <tr> <th></th> <th>AUX</th> <th>TUNER</th> <th>CD</th> <th>TAPE</th> </tr> </thead> <tbody> <tr> <td>O-FUNCA</td> <td>0</td> <td>0</td> <td>1</td> <td>1</td> </tr> <tr> <td>O-FUNCB</td> <td>0</td> <td>1</td> <td>0</td> <td>1</td> </tr> </tbody> </table>		AUX	TUNER	CD	TAPE	O-FUNCA	0	0	1	1	O-FUNCB	0	1	0	1
	AUX		TUNER	CD	TAPE													
O-FUNCA	0	0	1	1														
O-FUNCB	0	1	0	1														
40	O-EVRCLK	O	音量クロック出力															
41	O-EVRDATA	O	音量データ出力															
42	O-DATA	O	PLL IC データ出力															
43	O-CLK	O	PLL IC クロック出力															
44	O-PLLCE	O	PLL IC チップイネーブル															
45	I-TUNE/IFC	I	チューナー SD 検知入力、IF カウントシリアルデータ入力															
46	I-STEREO	I	チューナーステレオ検知入力															
47	I-RMC	I	システムリモコン信号入力															

端子番号	端子名称	I/O	機能説明
48	IC	-	GNDに接続
49	O-MUTE	O	システムミュート出力
50	$\overline{\text{O-POWER}}$	O	システム電源供給 $\overline{\text{ON}}$ /OFF 出力
51	$\overline{\text{O-PB1}}$	O	再生デッキ1, 2 スイッチ出力 "L" はデッキ1
52	VDD	-	電源供給入力
53~70	O-SEG-A~O-SWG-R	O	FLセグメント出力 P24 ~ P7
71	-VFL	-	FLディスプレイ用電源
72~77	O-SEG-S~O-SEG-X	O	FLセグメント出力 P6 ~ P1
78	O-INITIAL	O	出力イニシャルダイオード入力
79	O-TRYCLS	O	CDトレイクローズデータ出力
80	O-TRYOPN	O	CDトレイオープンデータ出力

IC, LC72131

端子番号	端子名称	I/O	機能説明																								
1	XIN	I/O	水晶発振子 (4.5MHz) に接続																								
22	XOUT																										
2	NC	-	未使用																								
3	CE	I	IC 起動、"H" でアクティブ																								
4	DI	I	適切キー作動時、CPU(μ PD78044HGF-201-3B9)からデジタルデータ入力																								
5	CLK	I	データDIでクロックする																								
6	DO	O	CPU(μ PD78044HGF-201-3B9)へデジタルデータ出力																								
7	TM-BASE	O	時計用リファレンスクロック信号 (8Hz) を出力																								
8	$\overline{\text{MONO}} / \text{BEAT}$	O	MONO/BEAT スイッチ時 "H" でを出力																								
9	$\overline{\text{FM}} / \text{AM}$	O	以下のように "L" または "H" を出力 <table border="1" style="margin-left: auto; margin-right: auto;"> <thead> <tr> <th colspan="2">2 BAND</th> <th colspan="3">3 BAND</th> <th colspan="3">3 BAND</th> </tr> <tr> <th>AM</th> <th>FM</th> <th>LW</th> <th>MW</th> <th>FM</th> <th>MW</th> <th>SW</th> <th>FM</th> </tr> </thead> <tbody> <tr> <td>H</td> <td>L</td> <td>H</td> <td>H</td> <td>L</td> <td>H</td> <td>L</td> <td>L</td> </tr> </tbody> </table>	2 BAND		3 BAND			3 BAND			AM	FM	LW	MW	FM	MW	SW	FM	H	L	H	H	L	H	L	L
2 BAND		3 BAND			3 BAND																						
AM	FM	LW	MW	FM	MW	SW	FM																				
H	L	H	H	L	H	L	L																				
10	$\overline{\text{MW}}$	O	以下のように "L" または "H" を出力 <table border="1" style="margin-left: auto; margin-right: auto;"> <thead> <tr> <th colspan="2">2 BAND</th> <th colspan="3">3 BAND</th> <th colspan="3">3 BAND</th> </tr> <tr> <th>AM</th> <th>FM</th> <th>LW</th> <th>MW</th> <th>FM</th> <th>MW</th> <th>SW</th> <th>FM</th> </tr> </thead> <tbody> <tr> <td>L</td> <td>L</td> <td>H</td> <td>L</td> <td>L</td> <td>L</td> <td>H</td> <td>L</td> </tr> </tbody> </table>	2 BAND		3 BAND			3 BAND			AM	FM	LW	MW	FM	MW	SW	FM	L	L	H	L	L	L	H	L
2 BAND		3 BAND			3 BAND																						
AM	FM	LW	MW	FM	MW	SW	FM																				
L	L	H	L	L	L	H	L																				
11	IF-MUTE	O	インターナルカウンターをコントロール																								
12	IFIN	I	ゼネラルパポーズカウンター入力																								
13	$\overline{\text{TUNE}}$	I	選局時、"L" を受信																								
14	NC	-	未使用																								
15	A MIN	I	AM ローカル発振周波数信号を受信																								
16	F MIN	I	FM ローカル発振周波数信号を受信																								
17	VDD	-	IC(+5V)へ電源供給																								
18	PD	O	PLLチャージポンプ出力																								
19	AIN	I	PLLアクティブ低域フィルター用 MOS トランジスター																								
20	AOUT	O																									
21	VSS	-	GND																								

IC DESCRIPTION (EXCEPT D)

IC, μ PD78044HGF-201-3B9 <EXCEPT 10EZ>

Pin No.	Pin Name	I/O	Description															
1~7	G7~G1	O	FL grid output.															
8	VDD	-	Power supply input.															
9	O-DISH-R	O	CD turntable reverse rotation output.															
10	O-DISH-F	O	CD turntable forward rotation output.															
11	O-CD-LED	O	CD flash window LED ON/OFF output.															
12	IO-BUS1	I/O	μ processor interface,data input/output.															
13	$\overline{\text{O-CCE}}$	O	μ processor interface,chip enable signal. When "L" : BUS 3~0 are active.															
14	IO-BUS2	I/O	μ processor interface,data input/output.															
15	IO-BUS0	I/O	μ processor interface,data input/output.															
16	IO-BUS3	I/O	μ processor interface,data input/output.															
17	$\overline{\text{RESET}}$	I	Reset input.															
18	I-RE-B	I	Rotary encoder A input.															
19	I-RE-A	I	Rotary encoder B input.															
20	A VSS	-	GND.															
21	O-MOTOR	O	Deck motor output.															
22	O-BUCK	O	μ processor interface,clock output.															
23	$\overline{\text{I-HOLD}}$	I	Power failure detected input "L" to stop clock and maintain memory.															
24	I-SW(CD)	I	CD mechanical switch A/D converter input.															
25	I-DISH-SENS	I	CD turntable photo sensor A/D converter input.															
26	I-TPSW	I	Deck mechanical switch A/D converter input.															
27,28	I-KEY1,0	I	Key input. (A/D)															
29	A VDD	-	Power supply input.															
30	A VREF	-	Reference voltage. (+5V)															
31	I-TMBASE	I	Reference clock input for timer watch.															
32	XT2(NC)	-	Not used.															
33	VSS	-	GND.															
34,35	X1,X2	I/O	4.19MHz oscillator circuit.															
36	O-CSHIFT	O	Micon clock shift output. (active high)															
37	O-FUNC-CD	O	Power supply for CD. Output $\overline{\text{ON/OFF}}$.															
38	O-FUNC-B	O	Function switch output.															
39	O-FUNC-A		<table border="1"> <thead> <tr> <th></th> <th>AUX</th> <th>TUNER</th> <th>CD</th> <th>TAPE</th> </tr> </thead> <tbody> <tr> <td>O-FUNCA</td> <td>0</td> <td>0</td> <td>1</td> <td>1</td> </tr> <tr> <td>O-FUNCB</td> <td>0</td> <td>1</td> <td>0</td> <td>1</td> </tr> </tbody> </table>		AUX	TUNER	CD	TAPE	O-FUNCA	0	0	1	1	O-FUNCB	0	1	0	1
	AUX		TUNER	CD	TAPE													
O-FUNCA	0	0	1	1														
O-FUNCB	0	1	0	1														
40	O-EVRCLK	O	Electrical volume clock output.															
41	O-EVRDATA	O	Electrical volume data output.															
42	O-DATA	O	PLL IC data output.															
43	O-CLK	O	PLL IC clock output.															
44	O-PLLCE	O	PLL IC chip enable.															
45	$\overline{\text{I-TUNE/IFC}}$	I	Tuner SD detected input. IF count serial data input.															
46	$\overline{\text{I-STEREO}}$	I	Tuner stereo detected input.															
47	$\overline{\text{I-RMC}}$	I	System remote control signal input.															

Pin No.	Pin Name	I/O	Description
48	IC	-	Connected to GND.
49	O-MUTE	O	System mute output.
50	$\overline{\text{O-POWER}}$	O	System power supply $\overline{\text{ON/OFF}}$ output.
51	$\overline{\text{O-PB1}}$	O	Playback Deck 1 and 2 switch output. "L" = Deck 1.
52	VDD	-	Power supply input.
53~70	A ~ R	O	FL segment output P24~P7.
71	-VFL	-	Power for FL display.
72~77	S ~ X	O	FL segment output P6~P1.
78	O-INITIAL	O	Output initial diode input.
79	O-TRYCLS(CD)	O	CD tray close data output.
80	O-TRYOPN(CD)	O	CD tray open data output.

IC, $\mu\text{PD78045HGF-017-3B9 <10EZ>$

Pin No.	Pin Name	I/O	Description
1~7	G7~G1	O	FL grid output.
8	VDD	-	Power supply input.
9	O-DISH-R	O	CD turntable reverse rotation output.
10	O-DISH-F	O	CD turntable forward rotation output.
11	O-CD-LED	O	CD flash window LED $\overline{\text{ON/OFF}}$ output.
12	IO-BUS1(CD)	I/O	BUS1(CD) output.
13	O-CCE(CD)	O	CCE(CD) output.
14	$\frac{\text{IO-BUS2(CD)}}{\text{I-TUNE/IFC}}$	I/O	BUS2(CD) output / IFC input.
15	$\frac{\text{IO-BUS0(CD)}}{\text{I-STEREO}}$	I/O	BUS0(CD) output / FM ST indicator.
16	$\frac{\text{IO-BUS3(CD)}}{\text{I-RDS DATA}}$	I/O	BUS3(CD) input / RDS data input.
17	RESET	-	Reset input.
18	I-RE·B	I	Rotary encoder A input.
19	I-RE·A	I	Rotary encoder B input.
20	A VSS	-	GND.
21	I-RDS AG	I	RDS signal input.
22	O-BUCK(CD)	O	Buck(CD) output.
23	$\overline{\text{I-HOLD}}$	I	Power failure detected input "L" to stop clock and maintain memory.
24	I-CDSW	I	CD mechanical switch A/D converter input.
25	I-DISH	I	CD turntable photo sensor A/D converter input.
26	I-TPSW	I	Deck mechanical switch A/D converter input.
27,28	I-KEY0,1	I	Key input. (A/D)
29	A VDD	-	Power supply input.
30	A VREF	-	Reference voltage. (+5V)

Pin No.	Pin Name	I/O	Description
31	I-TMBASE	I	Reference clock input for timer watch.
32	NC	-	Not used.
33	VSS	-	GND.
34,35	X1,X2	I/O	511.47Hz oscillator circuit.
36	O-CSHIFT	O	Micon clock shift output. (active high).
37	O-INITIAL	-	Not used.
38	O-TRY CLS(CD)	O	CD tray close / open output.
39	O-TRY OPN(CD)		
40	O-EVRCLK	O	Electrical volume clock output.
41	O-EVRDATA	O	Electrical volume data output.
42	O-DATA	O	PLL IC data output.
43	O-CLK	O	PLL IC clock output.
44	O-PLLCE	O	PLL IC chip enable.
45	O-MOTOR	O	Deck motor output.
46	I-RDS CLK	I	RDS input.
47	I-RMC	I	System remote control signal input.
48	IC	-	Connected to GND.
49	O-MUTE	O	System mute output.
50	O-POWER	O	System power supply ON/OFF output.
51	O-STRB	O	Shift register (STRB).
52	VDD	-	Power supply input.
53~70	O-SEG-A~O-SWG-R	O	FL segment output P24~P7.
71	-VFL	-	Power for FL display.
72~77	O-SEG-S~O-SEG-X	O	FL segment output P6~P1.
78~80	G10~G8	O	FL grid output.

Pin No.	Pin Name	I/O	Description																								
1	XIN	I/O	A crystal oscillator (4.5MHz) is connected between these pins.																								
22	XOUT																										
2	NC	-	Not used.																								
3	CE	I	To enable the IC. Active "H".																								
4	DI	I	Digital data input from CPU (μ PD78044HGF).																								
5	CLK	I	To clock in the data DI.																								
6	DO	O	Digital data output to CPU (μ PD78044HGF).																								
7	8Hz	O	Outputs a reference clock signal (8Hz) for the clock.																								
8	$\overline{\text{MONO}}$	O	Outputs "H" when MONO is switched.																								
9	$\overline{\text{FM}} / \text{AM}$	O	Output "L" or "H" as follows: <table border="1" style="margin-left: 20px;"> <thead> <tr> <th colspan="2">2 BAND</th> <th colspan="3">3 BAND</th> <th colspan="3">3 BAND</th> </tr> <tr> <th>AM</th> <th>FM</th> <th>LW</th> <th>MW</th> <th>FM</th> <th>MW</th> <th>SW</th> <th>FM</th> </tr> </thead> <tbody> <tr> <td>H</td> <td>L</td> <td>H</td> <td>H</td> <td>L</td> <td>H</td> <td>L</td> <td>L</td> </tr> </tbody> </table>	2 BAND		3 BAND			3 BAND			AM	FM	LW	MW	FM	MW	SW	FM	H	L	H	H	L	H	L	L
2 BAND		3 BAND			3 BAND																						
AM	FM	LW	MW	FM	MW	SW	FM																				
H	L	H	H	L	H	L	L																				
10	$\overline{\text{MW}}$	O	Outputs "L" or "H" as follows: <table border="1" style="margin-left: 20px;"> <thead> <tr> <th colspan="2">2 BAND</th> <th colspan="3">3 BAND</th> <th colspan="3">3 BAND</th> </tr> <tr> <th>AM</th> <th>FM</th> <th>LW</th> <th>MW</th> <th>FM</th> <th>MW</th> <th>SW</th> <th>FM</th> </tr> </thead> <tbody> <tr> <td>L</td> <td>L</td> <td>H</td> <td>L</td> <td>L</td> <td>L</td> <td>H</td> <td>L</td> </tr> </tbody> </table>	2 BAND		3 BAND			3 BAND			AM	FM	LW	MW	FM	MW	SW	FM	L	L	H	L	L	L	H	L
2 BAND		3 BAND			3 BAND																						
AM	FM	LW	MW	FM	MW	SW	FM																				
L	L	H	L	L	L	H	L																				
11	IFC	O	To control internal counter.																								
12	IFI	I	General purpose counter input.																								
13	$\overline{\text{TUNE}}$	I	Receives "L" when station is tuned.																								
14	NC	-	Not used.																								
15	AMI	I	Receives the AM local oscillator frequency signal.																								
16	FMI	I	Receives the FM local oscillator frequency signal.																								
17	VPU	-	Supply power to IC (+5V).																								
18	PD	O	PLL charge pump output.																								
19	AIN	I	The MOS transistor for PLL active low pass filter.																								
20	AOUT	O																									
21	VSS	-	Ground.																								

ADJUSTMENT - 1 <TUNER / DECK: D>

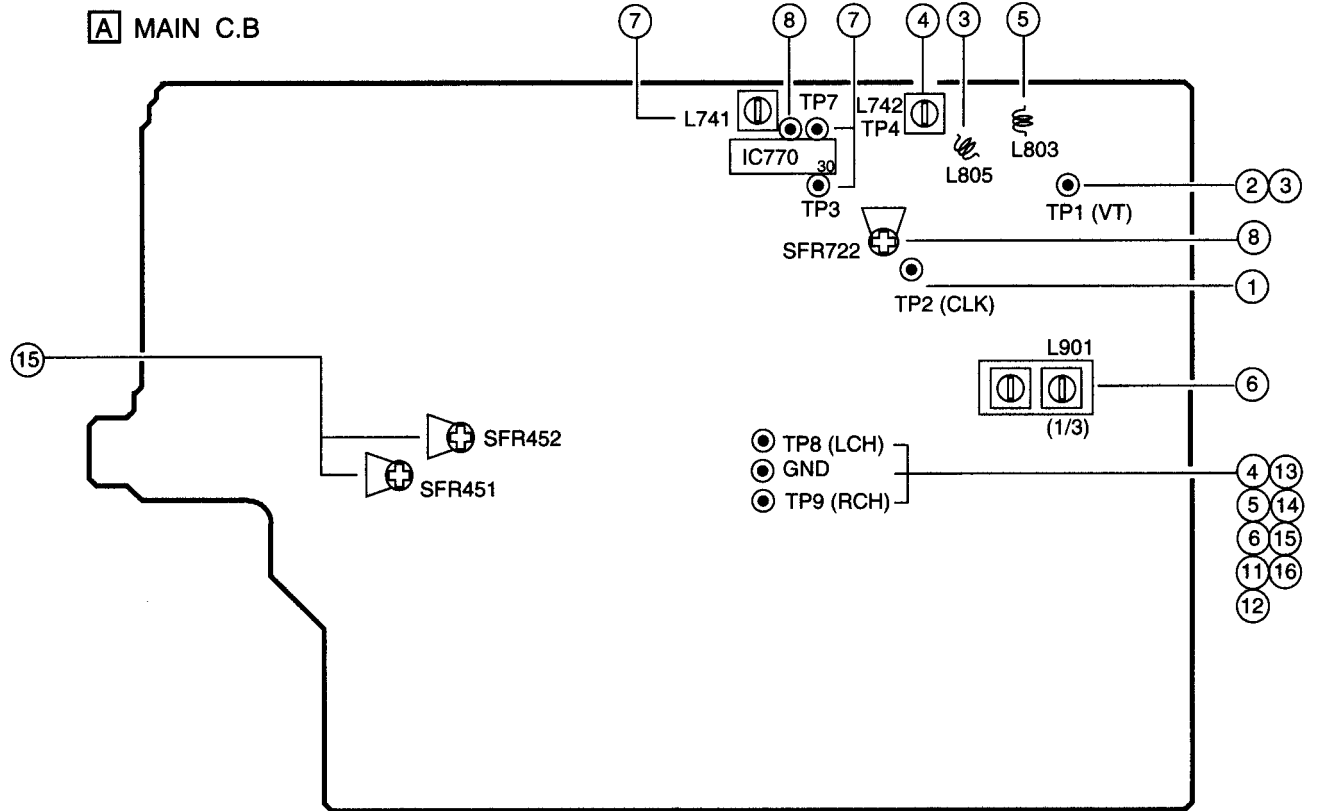

DECK-1 P, DECK-2 R / P / E HEAD

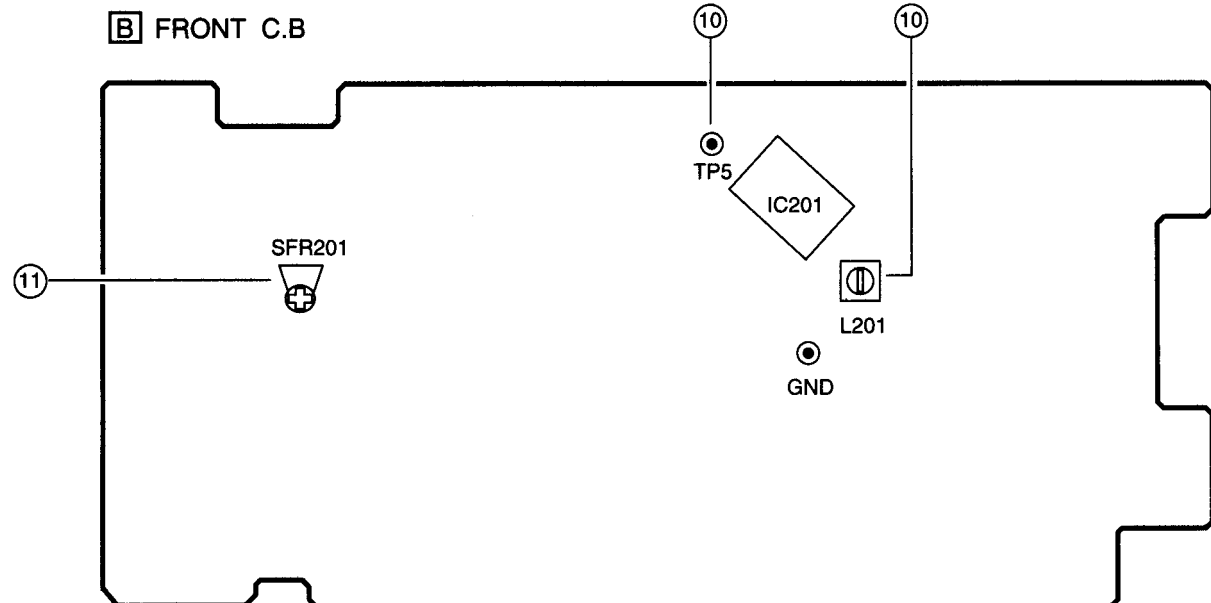
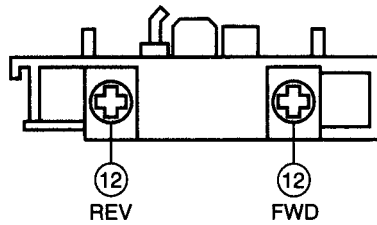

ADJUSTMENT - 1 <TUNER / DECK: EXCEPT D>

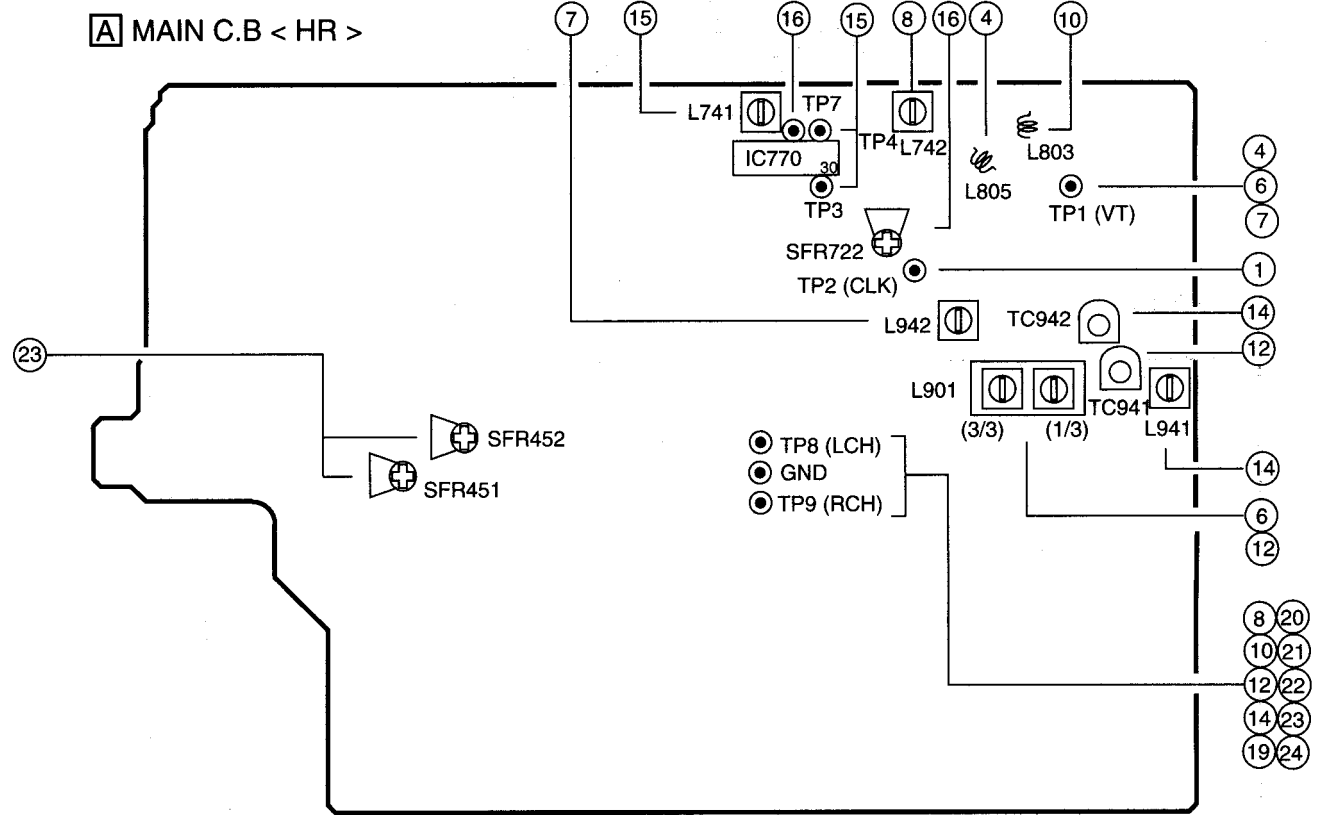
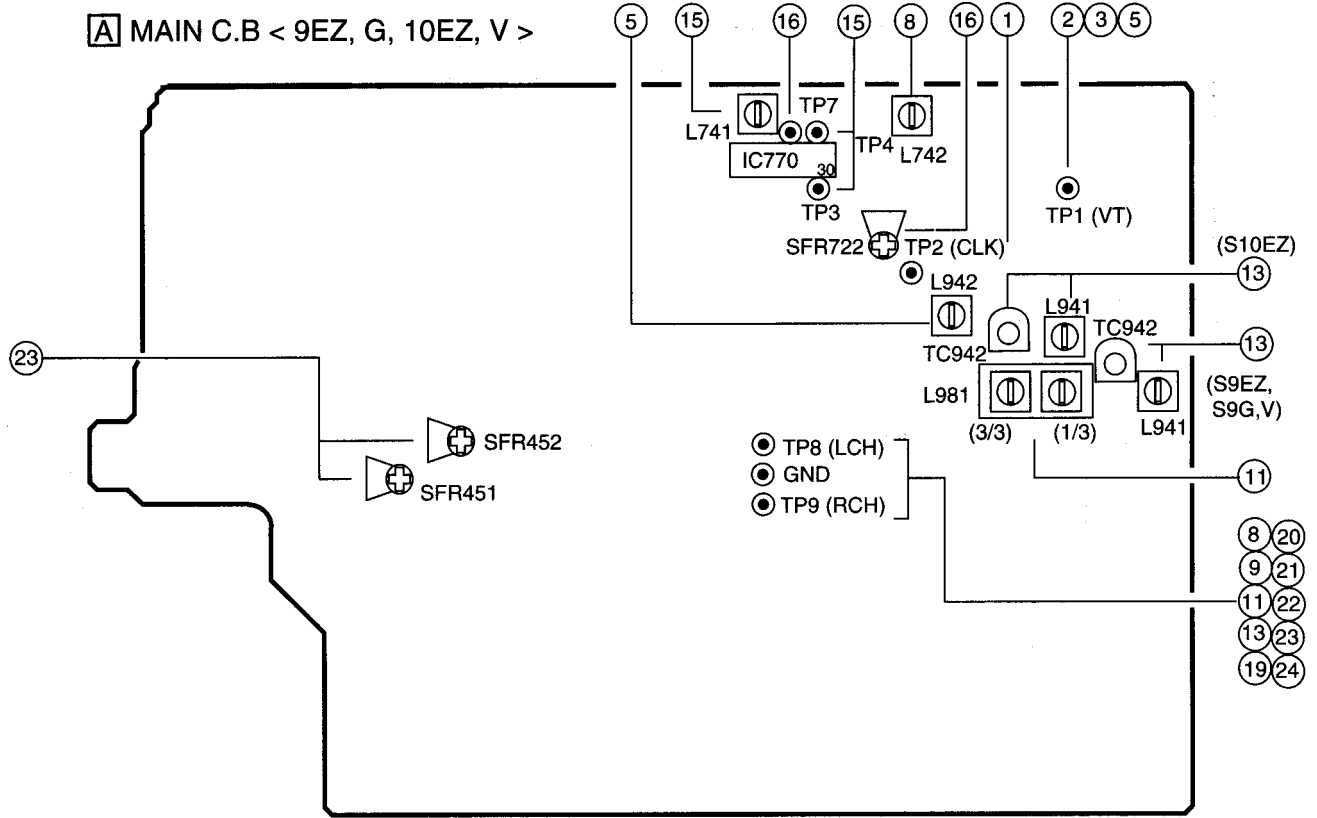

A MAIN C.B <HS>

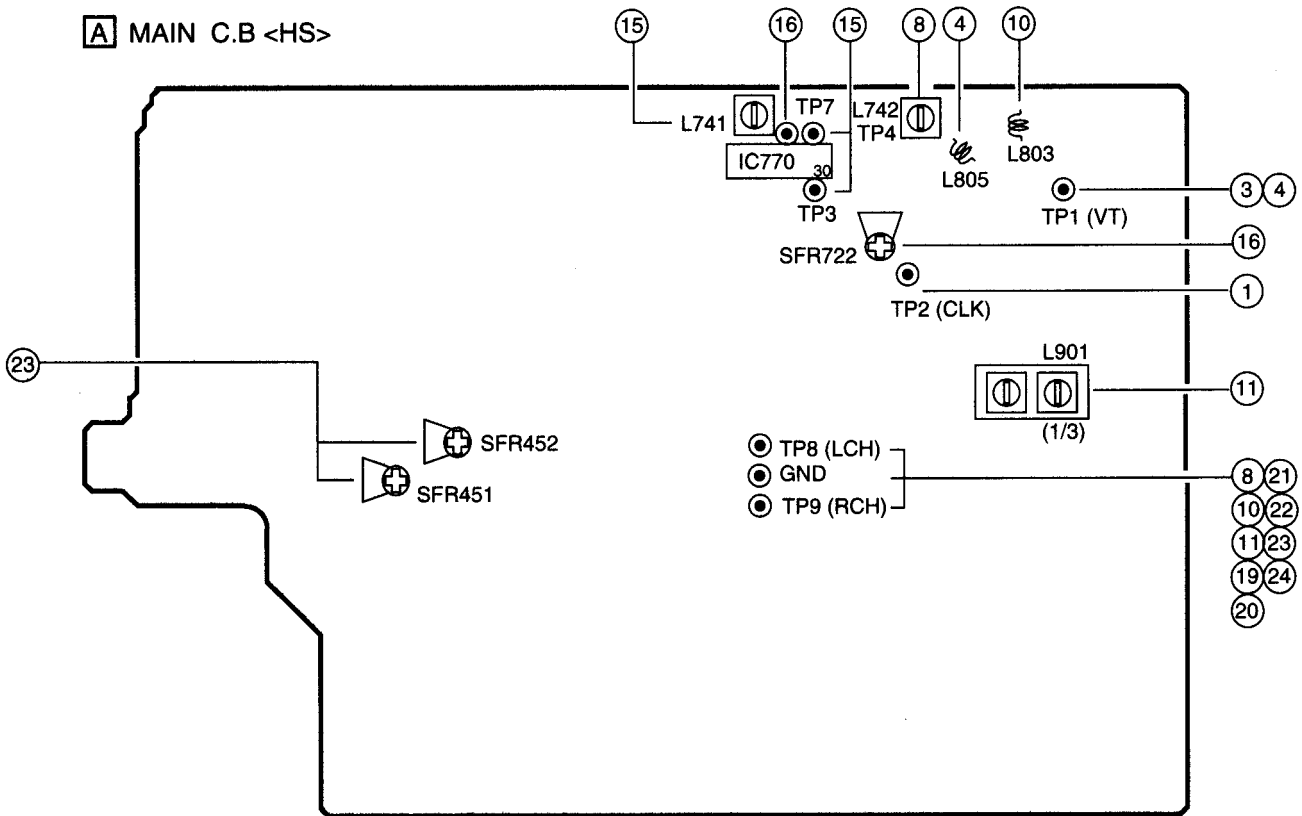

DECK-1 P, DECK-2 R / P / E HEAD

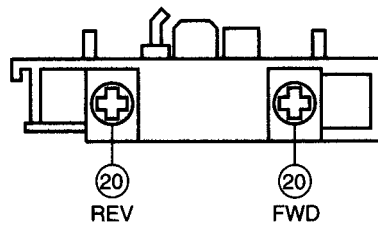

B FRONT C.B

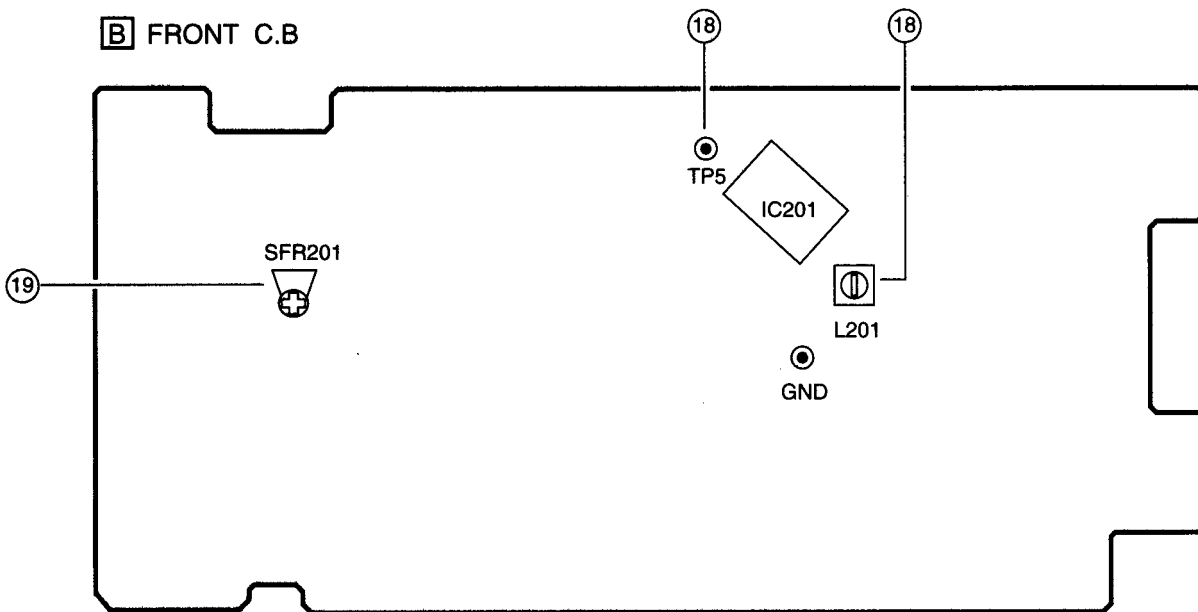

< TUNER SECTION >

1. Clock Frequency Check
Settings : • Test point : TP2
Method : Set to AM(MW) 1602kHz and check that the test point is $2052\text{kHz} \pm 0.08\text{kHz}$.
2. FM VT Check (9EZ,G,10EZ)
Settings : • Test point : TP1 (VT)
Method : Set to FM 87.5MHz,108.0MHz and check that the test point more than 1.5V(87.5MHz), less than 8.2V (108.0MHz).
2. FM VT Check (V)
Settings : • Test point : TP1 (VT)
Method : Set to FM 65.0MHz,108.0MHz and check that the test point more than 1.0V(65.0MHz), less than 9.5V (108.0MHz).
3. MW VT Check (9EZ,G,10EZ,V,HS)
Settings : • Test point : TP1 (VT)
Method : Set to MW 1602kHz and check that the test point is $5.6\text{V} \pm 1.0\text{V}$.
4. FM VT Adjustment (HR,HS)
Settings : • Test point : TP1 (VT)
• Adjustment location : L805
Method : Set to FM 87.5MHz, 108.0MHz and check that the test point is more than 1.0V(87.5MHz) and adjust L805 so that the test point becomes $7.0\text{V} \pm 0.05\text{V}$ (108.0MHz).
5. LW VT Adjustment (9EZ,G,10EZ,V)
Settings : • Test point : TP1 (VT)
• Adjustment location : L942
Method : Set to LW 144kHz and adjust L942 so that the test point becomes $1.3\text{V} \pm 0.05\text{V}$.
6. MW VT Adjustment (HR)
Settings : • Test point : TP1 (VT)
• Adjustment location : L901(3/3)
Method : Set to MW 1710kHz and adjust L901(3/3) so that the test point becomes $8.5\text{V} \pm 0.05\text{V}$.
7. SW VT Adjustment (HR)
Settings : • Test point : TP1 (VT)
• Adjustment location : L942
Method : Set to SW 17.9MHz and adjust L942 so that the test point becomes $7.0\text{V} \pm 0.05\text{V}$.
8. AM(MW) IF Adjustment
Settings : • Test point : TP8,TP9
• Input level : adjustable
• Adjustment location : L742
Method : Set to AM(MW) 999kHz and adjust L742 so that the test point becomes maximum.
9. FM Tracking Check (9EZ,G,10EZ)
Settings : • Test point : TP7, TP8
Method : Set to FM 98.0MHz and check that the test point is $10\text{dB} \pm 6\text{dB}$.
9. FM Tracking Check (V)
Settings : • Test point : TP7, TP8
Method : Set to FM 70.0MHz, 98.0MHz and check that the test point is $6\text{dB} \pm 6\text{dB}(70.0\text{MHz})$, $5\text{dB} \pm 6\text{dB}$ (98.0MHz).
10. FM Tracking Adjustment (HR,HS)
Settings : • Test point : TP8, TP9
• Input level : adjustable
• Adjustment location : L803
Method : The level at 87.5MHz is adjusted to maximum by L803 then check that the usable sensitivity is $0\text{dB} \pm 6\text{dB}(87.5\text{MHz})$, $4\text{dB} \pm 6\text{dB}(108.0\text{MHz})$.
11. AM Tracking Adjustment (HS)
Settings : • Test point : TP8, TP9
• Adjustment location : L901(1/3) 999kHz
Method : Set to AM(MW) 999kHz and adjust L901(1/3) so that the test point become maximum.
11. MW Tracking Adjustment (9EZ,G,10EZ,V)
Settings : • Test point : TP8, TP9
• Adjustment location : L981(1/3) 999kHz
Method : Set to AM(MW) 999kHz and adjust L981(1/3) so that the test point become maximum.
12. MW Tracking Adjustment (HR)
Settings : • Test point : TP8, TP9
• Adjustment location : L901(1/3) 603kHz
TC941 1404kHz
Method : Set up TC941 to center before adjustment, the level at 603kHz is adjusted to maximum by L901(1/3). Then the level at 1404kHz is adjusted to maximum by TC941.
13. LW Tracking Adjustment (9EZ,G,10EZ,V)
Settings : • Test point : TP8, TP9
• Adjustment location : L941 144kHz
TC942 290kHz
Method : Set up TC941 to center before adjustment, the level at 144kHz is adjusted to maximum by L941. Then the level at 290kHz is adjusted to maximum by TC942.
14. SW Tracking Adjustment (HR)
Settings : • Test point : TP8, TP9
• Input level : adjustable
• Adjustment location : L941 5.9MHz
TC942 17.9MHz
Method : Set up TC941 to center before adjustment, the level at 5.9MHz is adjusted to maximum by L941. Then the level at 17.9MHz is adjusted to maximum by TC942.
15. DC Balance / Mono Distortion Adjustment
Settings : • Test point : TP3, TP4
• Adjustment location : L741
• Input level : 54dB
Method : Set to FM 98.0MHz and adjust L741 so that the voltage between TP3 and TP4 becomes $0\text{V} \pm 0.04\text{V}$. Next, check that the distortion is less than 1.3% .
16. Auto Stop Level Adjustment
Settings : • Test point : TP7
• Adjustment location : SFR722
• Input level : 54dB
Method : Set to FM 98.0 MHz and adjust voltage low (about 0.1V) by SFR722. After that voltage high (about 7.0V) by 2dB down.
17. Auto Stop Level Check
AM(MW)
Method : Check auto stop at AM(MW) 999kHz and the level is 43 ~ 68 dB.

FM

Method : Check auto stop at FM 98.0MHz and the level is 20 dB \pm 10 dB.

SW (HR)

Method : Check auto stop at SW 12.0MHz and the level is 45 dB \pm 10 dB.

18. μ -con Clock Adjustment

Settings : • Test point : TP5
• Adjustment location : L201

Method : Connect frequency counter across TP5 and GND then adjust L201 so that the test point becomes 511.47 \pm 0.4Hz [9EZ, G,HR,HS,V], 371.92 \pm 0.4Hz [10EZ].

< DECK SECTION >

19. Tape Speed Adjustment

Settings : • Test tape : TTA-410
• Test point : TP8, TP9
• Adjustment location : SFR201

Method : Play back the test tape and adjust SFR201 so that the frequency counter reads 3000Hz \pm 5Hz.

20. Head Azimuth Adjustment

Settings : • Test tape : TTA-410
• Test point : TP8, TP9
• Adjustment location : Head azimuth adjustment screw

Method : Play back the 10kHz signal of the test tape and adjust screw so that the output becomes maximum. Next, perform on each FWD and REV PLAY mode.

21. PB Frequency Response Check (DECK 1, DECK 2)

Settings : • Test tape : TTA-320
• Test point : TP8, TP9

Method : Play back the 315Hz and 8kHz signals of the test tape and check that the output ratio of the 8kHz signal with respect to that of the 315Hz signal is \pm 5dB.

22. PB Sensitivity Check (DECK 1, DECK 2)

Settings : • Test tape : TTA-210
• Test point : TP8, TP9

Method : Play back the test tape and check that the output level of the test point is 150mV \pm 3.0dB .

23. REC/PB Frequency Response Adjustment

Settings : • Test tape : TTA-602
• Test point : TP8, TP9
• Input signal : 800Hz / 8kHz (LINE IN)
• Adjustment location : SFR451 (Lch)
SFR452 (Rch)

Method : Apply a 800Hz signal and REC mode. Then adjust OSC attenuator so that the output level at the TP8, TP9 becomes 11mV. Record and play back the 800Hz and 8kHz signals and adjust SFRs so that the output of the 8kHz signals becomes 12mV (+1.0dB) \pm 0.5dB with respect to that of the 800Hz signal.

24. REC/PB Sensitivity Check

Settings : • Test tape : TTA-602
• Test point : TP8, TP9
• Input signal : 800Hz (LINE IN)

Method : Apply a 800Hz signal and REC mode. Then adjust OSC attenuator so that the output level at the TP8, TP9 becomes 11mV. Record and play back the 800Hz signals and check that the output is 10mV (-1.0dB) \pm 2.5dB.

PRACTICAL SERVICE FIGURE

<TUNER SECTION>

<FM SECTION>

IHF Sensitivity : V :
10dB ± 4dB [at 65.0 MHz]
6dB ± 4dB [at 70.0 / 74.0 MHz]
5dB ± 4dB [at 87.5 / 98.0 / 108.0MHz]
(THD 3%) D :
1dB ± 6dB [at 76.0MHz]
4dB ± 6dB [at 83.0MHz]
-2dB ~ 16dB [at 108.0MHz]
9EZ,G,10EZ :
11dB ± 6dB [at 87.5 / 98.0MHz]
1dB ~ 19dB [at 108.0MHz]
HR,HS :
1dB ± 6dB [at 87.5MHz]
4dB ± 6dB [at 98.00MHz]
-2dB ~ 16dB [at 108.0MHz]
Quieting sensitivity : STEREO
V :
Less than 36dB
[at 65.0 / 70.0 / 74.0MHz]
[at 87.5 / 98.0 / 108.0MHz]
(at S/N 50dB) D,HR,HS :
Less than 35dB
[at 76.0 / 83.0 / 108.0MHz(D)]
[at 87.5 / 98.0 / 108.0MHz(HR,HS)]
(at S/N 46dB) 9EZ,G,10EZ :
Less than 36dB
[at 87.5 / 98.0 / 108.0MHz]
Signal to noise ratio : STEREO
D,HR,HS :
More than 60dB
[at 83.0MHz(D)]
[at 98.0MHz(HR,HS)]
V :
More than 55dB
[at 70.0 / 98.0MHz]
MONO
D,HR,HS :
More than 70dB
[at 83.0MHz(D)]
[98.0MHz(HR,HS)]
9EZ,G,10EZ :
More than 67dB
[at 98.0MHz]
V :
More than 65dB
[at 70.0 / 98.0MHz]
Distortion : STEREO
D,HR,HS,9EZ,G,10EZ :
Less than 2.0%
[at 83.0MHz(D)]
[at 98.0MHz(HR,HS,9EZ,G,10EZ)]
V :
Less than 2.3%
[at 70.0MHz]
MONO
D,HR,HS,9EZ,G,10EZ :
Less than 1.3%
[at 83.0MHz(D)]
[at 98.0MHz(HR,HS,9EZ,G,10EZ)]
V :
Less than 1.5%
[at 70.0MHz]
Auto stop level : 10 ~ 30dB
[at 70.0MHz(V)]
[at 83.0MHz(D)]
[at 98.0MHz(HR,HS,9EZ,G,10EZ)]

Stereo separation : D,HR,HS :
More than 28dB
[at 83.0MHz(D)]
[at 98.0MHz(HR,HS)]
9EZ,G,10EZ,V :
More than 20dB
[at 98.0MHz(9EZ,G,10EZ)]
[at 70.0 / 98.0MHz(V)]
Intermediate frequency : 10.7MHz

<AM(MW) SECTION>

Sensitivity : Less than 66dB
(S/N 20dB) [at 603kHz]
Less than 60dB
[at 999kHz/1404kHz]
Signal to noise ratio : More than 30dB
[at 999kHz]
Distortion : Less than 3.0%
[at 999kHz]
Auto stop level : 43dB ~ 68dB
[at 999kHz]
Stereo separation : D :
More than 12dB
[at 999kHz]
Intermediate frequency : 450kHz

<LW SECTION> (9EZ,G,10EZ,V only)

Sensitivity : Less than 72dB
(S/N 20dB) [at 144 / 198 / 290kHz]
Signal to noise ratio : More than 30dB
[at 198kHz]
Distortion : Less than 1.5%
[at 198kHz]
Intermediate frequency : 450kHz

<SW SECTION> (HR only)

Sensitivity : Less than 47dB [at 5.9MHz]
(S/N 20dB) Less than 41dB [at 12.0 / 17.9MHz]
Signal to noise ratio : More than 35dB
[at 12.0MHz]
Distortion : Less than 1.5%
[at 12.0MHz]
Intermediate frequency : 450kHz

<DECK SECTION>

Tape speed : 3000Hz ± 45Hz
Wow & flutter : Less than 0.35%
(RMS)
Take-up torque : 30 ~ 60g-cm
(FWD, REV)
F.F & REW torque : 55 ~ 140g-cm
Back tension : 2 ~ 5g-cm
(FWD, REV)
PB output level : 2.8V ± 3dB
(SP OUT 2V)
REC/PB output level : 2.0V ± 3.5dB
(SP OUT 2V,NORM)
Distortion (REC/PB) : Less than 2.0% (NORM)
Noise level (PB) : Less than 20mV

(NORM,SP OUT 2V,DOLBY OFF)
 Noise level (REC/PB) : Less than 35mV
 (NORM,SP OUT 2V,DOLBY OFF)
 Crosstalk : More than 55dB
 (SP OUT 2V,1kHz)
 Channel separation : More than 35 dB
 (SP OUT 2V,1kHz)
 Erasing ratio : More than 55dB
 (at 400Hz, 10VU,NORM)
 Test tape : NORM : TTA-602

ACCESSORIES / PACKAGE LIST

If can't understand for Description please kindly refer to "REFERENCE NAME LIST".

REF. NO.	PART NO.	KANRI NO.	DESCRIPTION
1	87-NF9-909-019	IB, E(ECA)	-C<HR>
1	87-NF9-910-019	IB, E(EGFSI)	-C<10EZ>
1	87-NF9-911-019	IB, V-C<V>	
1	87-NF9-912-019	IB, E(EGFSI)	-C-9<9EZ>
1	87-NF9-913-010	-- IB, D(J)	-I<D>
1	87-NF9-922-019	IB, HS(K)	-C<HS>
1	87-NF9-920-010	IB, G(E)	-C<G>
2	87-A90-030-010	ANT, LOOP AM-NC	C<10EZ, 9EZ, G>
3	87-A90-054-010	-- ANT, LOOP AM-CON	C<HR, HS, V, D>
4	87-A90-118-010	ANT, WIRE FM(Z)	<10EZ, 9EZ, G>
5	87-043-115-010	ANT, FEEDER FM	<HR>
6	87-A90-119-010	ANT, WIRE SW (5M)	<HR>
7	86-NFZ-638-110	RC UNIT, RC-6AS14	
8	87-A90-312-016	PLUG, CONVERSION WTN-1157R1	<HR>

MECHANICAL EXPLODED VIEW 1 / 1

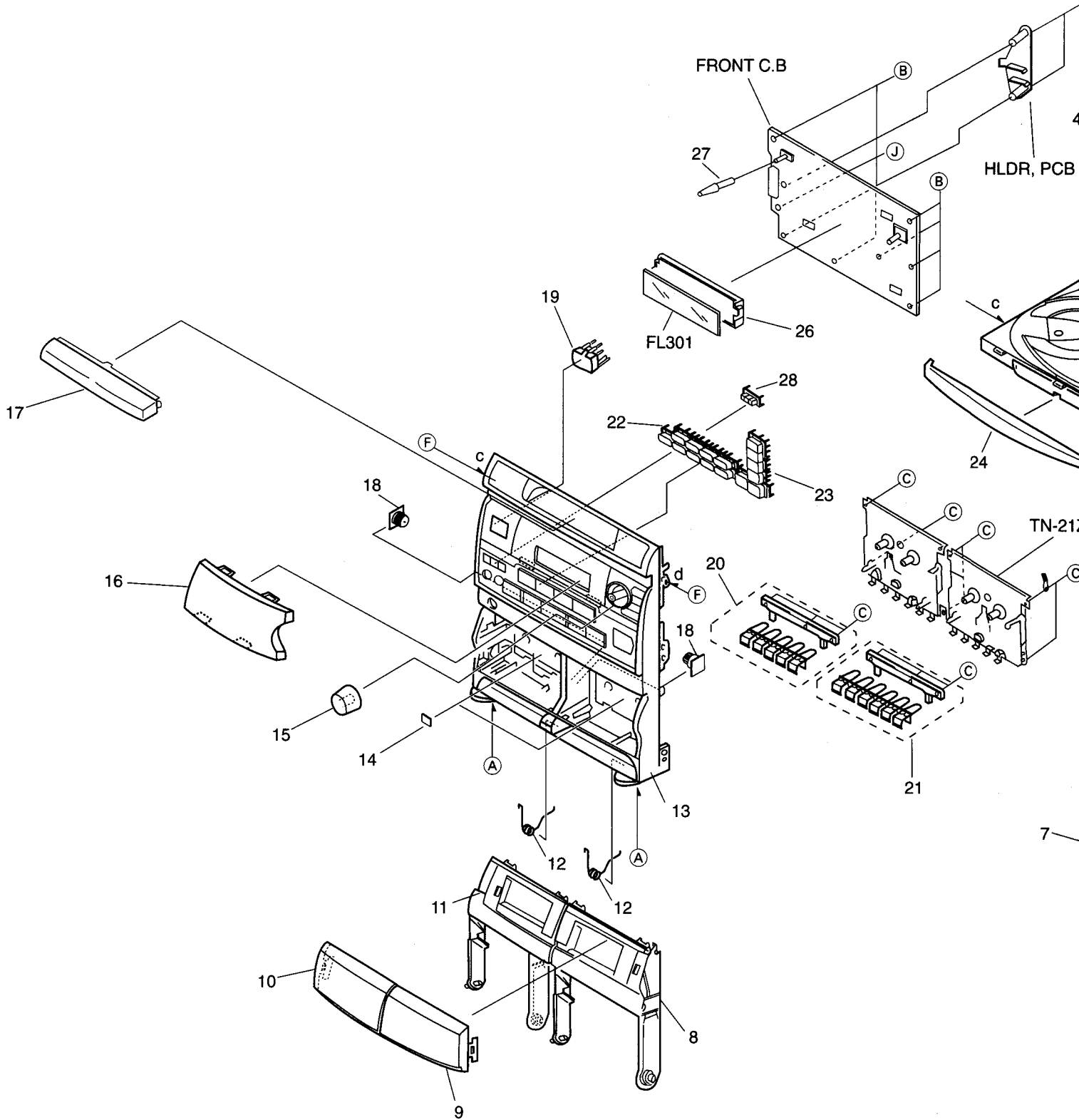

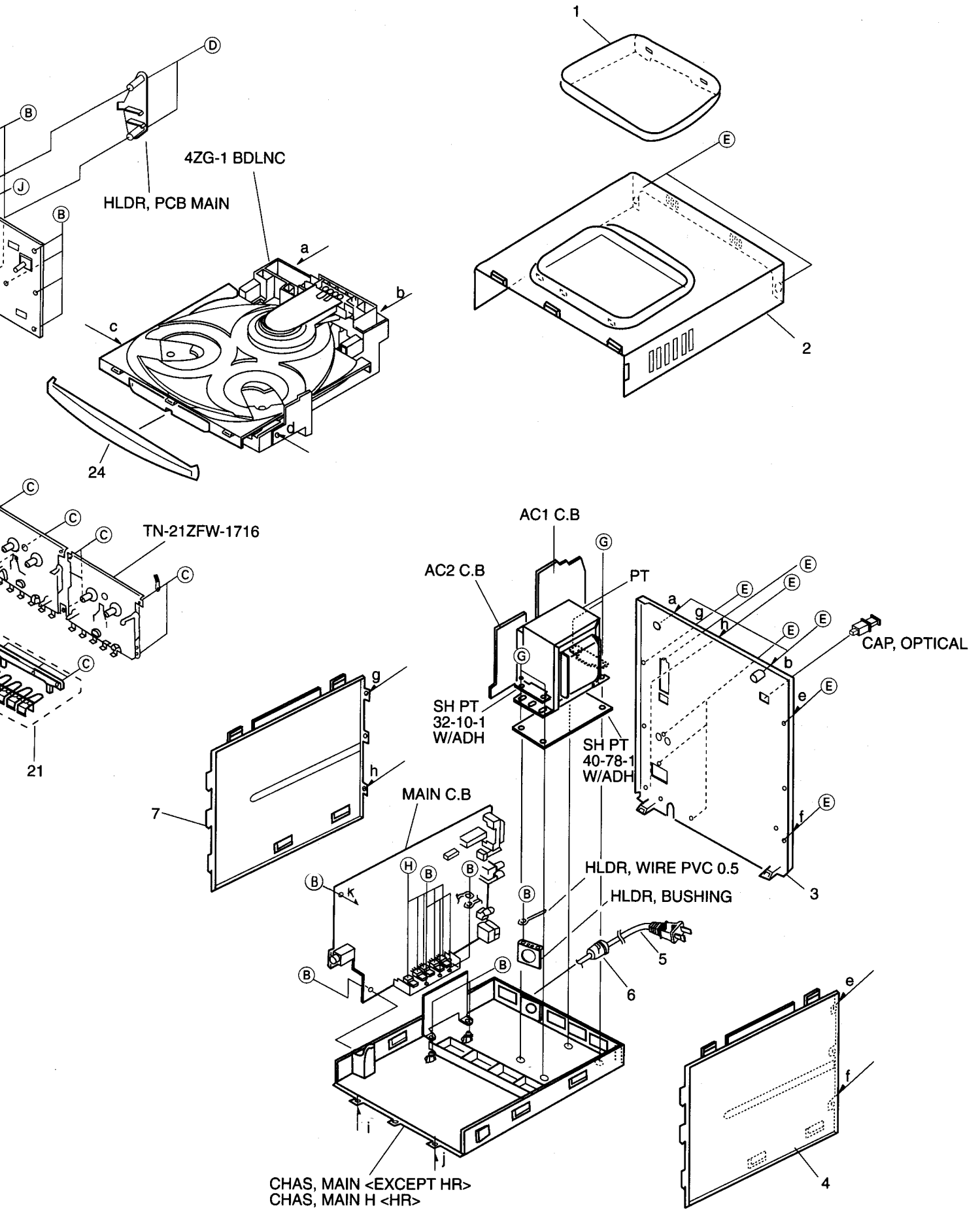

MECHANICAL PARTS LIST 1 / 1

If can't understand for Description please kindly refer to "REFERENCE NAME LIST".

REF. NO.	PART NO.	KANRI NO.	DESCRIPTION	REF. NO.	PART NO.	KANRI NO.	DESCRIPTION
1	86-NFZ-001-010	--	WINDOW, TOP	13	87-NF9-007-010		CABI, FR V<V>
2	87-NF9-055-010	--	PANEL, TOP	14	81-532-080-010	1A	LBL, CASS-COMPT
3	87-NF9-022-010		CABI, REAR EZSTNC(RDS)<10EZ>	15	87-NF9-048-010	--	KNOB, RTRY VOL
3	87-NF9-015-010		CABI, REAR VJSTNM<V>	16	87-NF9-034-010		WINDOW, DISP E(RDS)<10EZ>
3	87-NF9-027-010		CABI, REAR HSSTNC<HS>	16	87-NF9-039-010		WINDOW, DISP<HR, HS>
3	87-NF9-028-010	--	CABI, REAR STNC<D>	16	87-NF9-040-010	--	WINDOW, DISP U<9EZ, G, V, D>
3	87-NF9-025-010		CABI, REAR GSTNC<G>	17	87-NF9-038-010	--	WINDOW, CD
3	87-NF9-023-010		CABI, REAR E1STNC<9EZ>	18	87-063-164-010	--	OIL-DMPR,
3	87-NF9-013-010		CABI, REAR HRJSTNM<HR>	19	87-NF9-044-110		KEY, POWER<EXP D>
4	87-NF9-057-010	--	PANEL, RIGHT	19	87-NF9-058-010	--	KEY, POWER<D>
⚠	5	87-050-079-010	AC CORD ASSY, BLK<HR, 10EZ, 9EZ, V>	20	87-NF9-041-010	--	KEY, CASS L
⚠	5	87-050-081-110	AC CORD ASSY, G<G>	21	87-NF9-042-010	--	KEY, CASS R
⚠	5	87-A80-006-010	AC CORD ASSY, HS<HS>	22	87-NF9-046-010	--	KEY, ASSY 1
⚠	5	87-050-098-010	1B AC CORD ASSY, D BLK<D>	23	87-NF9-047-010		KEY, ASSY 2<EXP D>
	6	87-085-184-010	0E BUSHING, AC CORD (D) CM-22A<D>	23	87-NF9-054-010	--	KEY, ASSY 2B<D>
	6	87-085-185-010	BUSHING, CORD (E)CM-22B<EXP D>	24	87-NF9-050-010		PANEL, TRAY U<EXP D>
	7	87-NF9-056-010	--	24	87-NF9-051-010	--	PANEL, TRAY B<D>
	8	87-NF9-031-010	BOX, CASS R<HR, HS>	25	82-NE6-067-010	--	BADGE, AIWA 30N
	8	87-NF9-033-010	BOX, CASS UR<10EZ, 9EZ, V, G>	26	82-NF7-210-110	--	GUIDE, FL
	8	87-NF9-053-010	--	27	87-NF9-049-010		KNOB RTRY MIC<HR, HS>
	9	87-NF9-037-010	--	A	87-067-581-010	--	BVT2+3-15 W/O SLOT
	10	87-NF9-036-010	--	B	87-067-703-010	0E	BVT2+3-10 W/O SLOT
	11	87-NF9-030-010	BOX, CASS L<HR, HS>	C	87-067-758-010	0E	BVT2+3-12 W/O SLOT
	11	87-NF9-032-010	BOX, CASS UL<10EZ, 9EZ, V, G>	D	87-067-698-010	--	BVT2+3-18 W/O SLOT
	11	87-NF9-052-010	--	E	87-067-761-010	0E	BVT2+3-10 BLK
	12	82-NF7-218-010	--	F	87-721-097-410	0E	QT2+3-12 GLD
	13	87-NF9-002-010	CABI, FR HE<HR, HS>	G	87-741-172-410	--	UT2+4-12 W/O SLOT
	13	87-NF9-004-010	CABI, FR E RDS<10EZ>	H	87-067-579-010	0E	BVT2+3-8 W/O SLOT
	13	87-NF9-005-010	--	J	87-661-096-410	--	VFT1+3-10
	13	87-NF9-006-010	CABI, FR E1<9EZ, G>				

TAPE MECHANISM EXPLODED VIEW 1 / 2

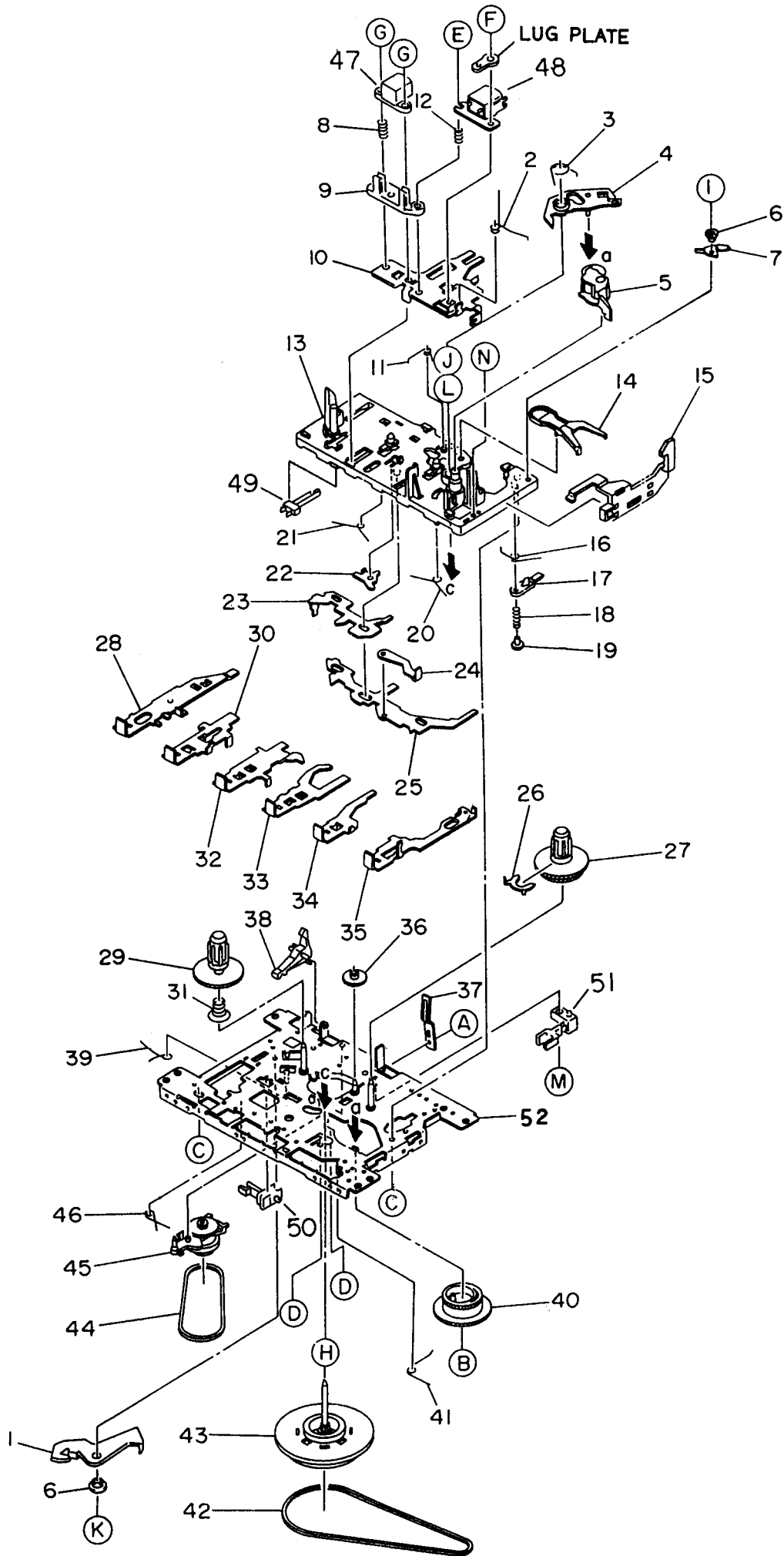

TAPE MECHANISM PARTS LIST 1/2

If can't understand for Description please kindly refer to "REFERENCE NAME LIST".

REF. NO.	PART NO.	KANRI NO.	DESCRIPTION	REF. NO.	PART NO.	KANRI NO.	DESCRIPTION
1	S1-921-020-010	0E	REC ARM	36	S1-821-100-700	0E	FF GEAR
2	S1-921-030-090	0E	PANEL P SPRING	37	S1-829-100-010	0E	PACK SPRING
3	S1-921-260-050	0E	GEAR PLATE SPRING	38	S1-821-100-690	1C	RECORD SAFETY LEVER
4	S1-921-265-020	0E	GEAR PLATE ASSY	39	S1-921-140-210	1A	REC BUTTON LEVER SPRING
5	S1-921-043-100	1C	PINCH ROLLER ARM ASSY	40	S1-921-260-020	1B	CAM GEAR
6	S1-921-140-370	0E	P ARM COLLER	41	S1-921-140-160	0E	E ACTUATOR SPRING
7	S1-921-140-340	0E	P ARM	42	S1-921-090-240	1C	MAIN BELT
8	S1-821-030-080	0E	EH SPRING	43	S1-921-093-030	0E	FLYWHEEL ASSY
9	S1-921-030-060	0E	HEAD BASE	44	S1-821-070-110	0E	RF BELT
10	S1-921-030-140	0E	HEAD PANEL	45	S1-921-073-080	??	RF CLUTCH ASSY
11	S1-921-141-8A0	0E	M CONTROL SPRING	46	S1-921-140-170	1H	P.S.LEVER SPRING
12	S1-821-030-070	0E	AZIMUTH SPRING	47	S6-202-140-190	1E	E HEAD
13	S1-921-143-180	1C	BASE ASSY	48	S6-201-010-750	0E	R.P.HEAD RP-7442BS
14	S1-921-260-4A0	0E	SENSING LEVER	49	S6-401-011-490	1B	LEAF SW MSW-1541T
15	S1-921-130-020	0E	EJECT SLIDE LEVER	50	S6-401-011-610	1B	LEAF SW MSW-17820MVEI
16	S1-921-141-3A0	1C	P CONTROL SPRING	51	S6-401-010-380	1B	LEAF SW MSW-1275
17	S1-921-140-550	2B	PAUSE LEVER(E)	52	S1-921-015-010	??	CHASSIS ASSY
18	S1-921-140-120	0E	PAUSE LEVER SPRING	A	S9-179-000-000	0E	C TAP SCREW M2-3
19	S1-921-140-110	1H	PAUSE STOPPER	B	S9-422-000-000	0E	P WASHER CUT 12-3.8-0.3
20	S1-921-140-150	0E	BUTTON LEVER SPRING(B)	C	S9-679-000-000	0E	P TAP SCREW M2-5
21	S1-921-140-140	1F	BUTTON LEVER SPRING(A)	D	S9-999-180-090	0E	TAP SCREW M2-4.5
22	S1-921-140-200	0E	PR STOPPER	E	S9-922-000-000	0E	AZIMUTH SCREW M2-8
23	S1-921-140-090	0E	SWITCH ACTUATOR	F	S9-115-000-000	0E	+ BIND SCREW M2-3
24	S1-921-140-640	0E	E KICK LEVER	G	S9-821-000-000	0E	+ -CAP SCREW M2-8
25	S1-921-140-080	1E	PUSH BUTTON ACTUATOR	H	S9-882-000-000	0E	P WASHER 2-3.5-0.4
26	S1-921-050-060	0E	SENSOR	I	S9-999-200-410	1B	P TAP SCREW M2-3
27	S1-921-053-030	1F	TAKE UP REEL ASSY	J	S9-999-030-130	0E	P WASHER CUT 1.45-3.8-0.
28	S1-921-140-220	0E	REC BUTTON LEVER	K	S9-180-000-000	0E	C TAP SCREW M2-4
29	S1-921-053-040	1E	SUPPLY REEL ASSY	L	S9-999-000-030	0E	P WASHER2.1-4-0.13
30	S1-921-140-230	1D	PLAY BUTTON LEVER	M	S9-181-000-000	1F	C TAP SCREW M2-5
31	S1-821-100-990	0E	BACK TENSION SPRING	N	S9-P05-200-610	0E	S TAPPING SCREW M2-6
32	S1-921-140-240	0E	REW BUTTON LEVER				
33	S1-921-140-250	0E	FF BUTTON LEVER				
34	S1-921-140-660	1A	STOP BUTTON LEVER				
35	S1-921-140-610	1F	PAUSE BUTTON LEVER				

TAPE MECHANISM EXPLODED VIEW 2 / 2

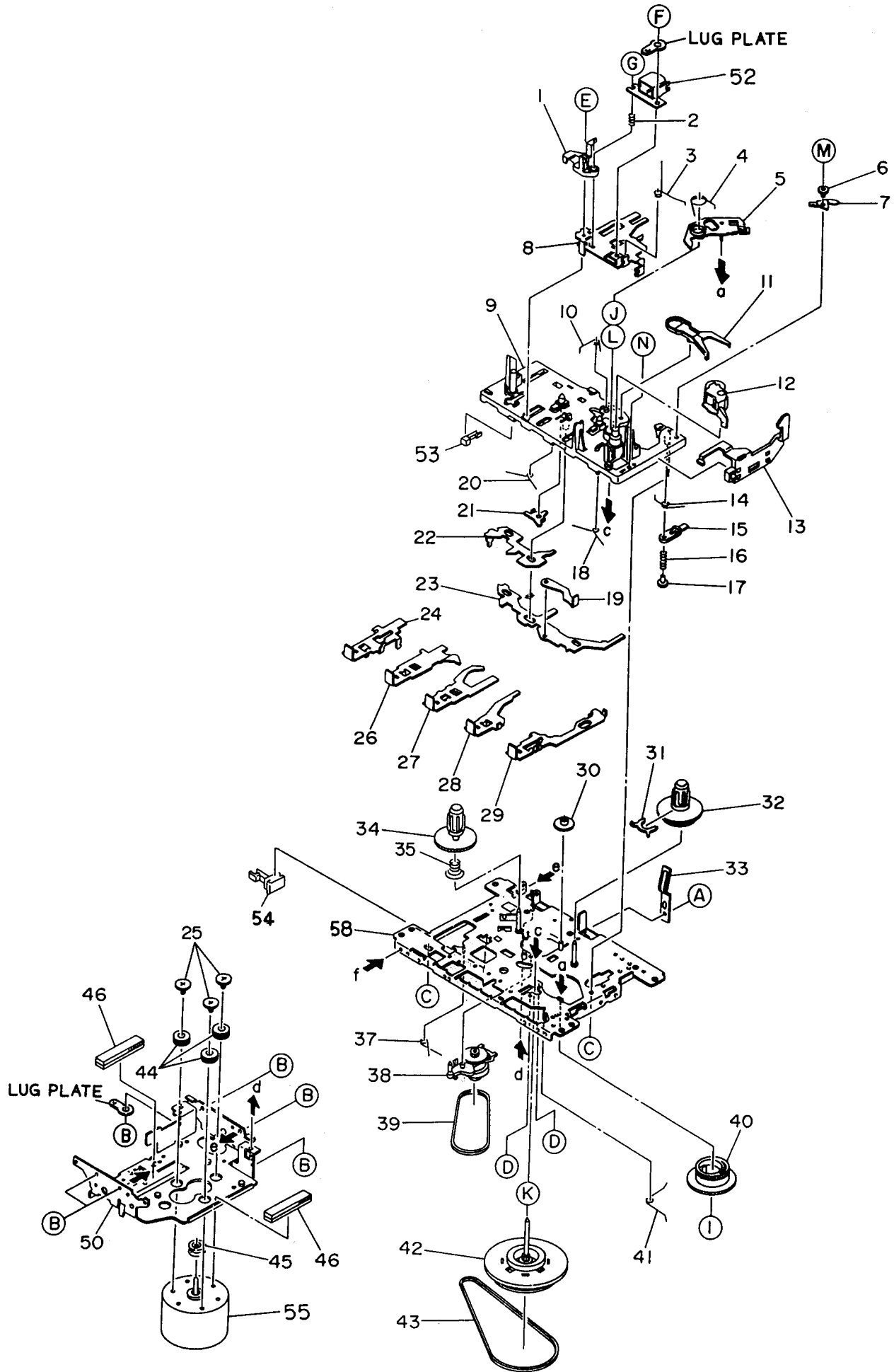

TAPE MECHANISM PARTS LIST 2 / 2

If can't understand for Description please kindly refer to "REFERENCE NAME LIST".

REF. NO.	PART NO.	KANRI NO.	DESCRIPTION	REF. NO.	PART NO.	KANRI NO.	DESCRIPTION
1	S1-921-030-4A0	0E	HEAD BASE	37	S1-921-140-170	1H	P.S.LEVER SPRING
2	S1-821-030-070	0E	AZIMUTH SPRING	38	S1-921-073-080	??	RF CLUTCH ASSY
3	S1-921-030-090	0E	PANEL P SPRING	39	S1-821-070-110	0E	RF BELT
4	S1-921-260-050	0E	GEAR PLATE SPRING	40	S1-921-260-020	1B	CAM GEAR
5	S1-921-265-020	0E	GEAR PLATE ASSY	41	S1-921-140-160	0E	E ACTUATOR SPRING
6	S1-921-140-370	0E	P ARM COLLER	42	S1-921-093-040	1F	FLYWHEEL ASSY
7	S1-921-140-340	0E	P ARM	43	S1-921-090-240	1C	MAIN BELT
8	S1-921-030-110	1A	HEAD PANEL	44	S1-820-130-060	0E	MOTOR RUBBER
9	S1-921-143-170	0E	BASE ASSY	45	S1-921-120-130	0E	MOTOR PULLEY
10	S1-921-141-8A0	0E	M CONTROL SPRING	46	S1-921-120-120	1B	ANTI VIBR FELT MAT
11	S1-921-260-4A0	0E	SENSING LEVER	50	S1-921-120-110	1B	MOTOR BRACKET
12	S1-921-043-100	1C	PINCH ROLLER ARM ASSY	52	S6-201-010-750	0E	R.P.HEAD RP-7442BS
13	S1-921-130-020	0E	EJECT SLIDE LEVER	53	S6-401-011-490	1B	LEAF SW MSW-1541T
14	S1-921-141-3A0	1C	P CONTROL SPRING	54	S6-401-011-610	1B	LEAF SW MSW-17820MVE1
15	S1-921-140-550	2B	PAUSE LEVER(E)	55	S6-002-030-290	2M	MOTOR EG530YD-2BH
16	S1-921-140-120	0E	PAUSE LEVER SPRING	58	S1-921-015-010	??	CHASSIS ASSY
17	S1-921-140-110	1H	PAUSE STOPPER	A	S9-179-000-000	0E	C TAP SCREW M2-3
18	S1-921-140-150	0E	BUTTON LEVER SPRING(B)	B	S9-180-000-000	0E	C TAP SCREW M2-4
19	S1-821-011-590	0E	E KICK LEVER	C	S9-679-000-000	0E	P TAP SCREW M2-5
20	S1-921-140-140	1F	BUTTON LEVER SPRING(A)	D	S9-999-180-090	0E	TAP SCREW M2-4.5
21	S1-921-140-200	0E	PR STOPPER	E	S9-004-000-000	0E	SCREW M2-6
22	S1-921-140-090	0E	SWITCH ACTUATOR	F	S9-115-000-000	0E	+ BIND SCREW M2-3
23	S1-921-140-080	1E	PUSH BUTTON ACTUATOR	G	S9-922-000-000	0E	AZIMUTH SCREW M2-8
24	S1-921-140-230	1D	PLAY BUTTON LEVER	I	S9-422-000-000	0E	P WASHER CUT 12-3.8-0.3
25	S1-821-120-020	0E	MOTOR COLLER SCREW	J	S9-999-030-130	0E	P WASHER CUT 1.45-3.8
26	S1-921-140-240	0E	REW BUTTON LEVER	K	S9-882-000-000	0E	P WASHER 2-3.5-0.4
27	S1-921-140-250	0E	FF BUTTON LEVER	L	S9-999-000-030	0E	P WASHER2.1-4-0.13
28	S1-921-140-260	0E	STOP BUTTON LEVER	M	S9-999-200-410	1B	P TAP SCREW M2-3
29	S1-921-140-610	1F	PAUSE BUTTON LEVER	N	S9-P05-200-610	0E	S TAPPING SCREW M2-6
30	S1-821-100-700	0E	FF GEAR				
31	S1-921-050-060	0E	SENSOR				
32	S1-921-053-030	1F	TAKE UP REEL ASSY				
33	S1-829-100-010	0E	PACK SPRING				
34	S1-921-053-040	1E	SUPPLY REEL ASSY				
35	S1-821-100-990	0E	BACK TENSION SPRING				

SPEAKER DISASSEMBLY INSTRUCTIONS

Type.1

Insert a flat-bladed screwdriver into the position indicated by the arrows and remove the panel. remove the screws of each speaker unit and then remove the speaker units.

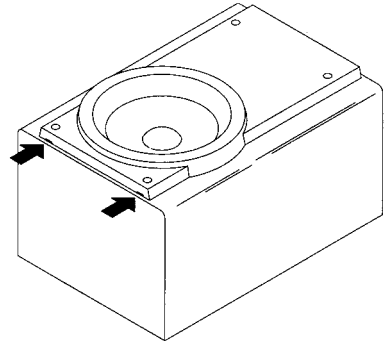

Type.2

Remove the grill frame and four pieces fo rubber caps by pulling out with a flat-bladed screwdriver. Remove the screws from hole where installed rubber caps. Insert a flat-bladed screwdriver into the position indicated by the arrows and remove the panel. Remove the screws of each speaker unit and then remove the speaker units.

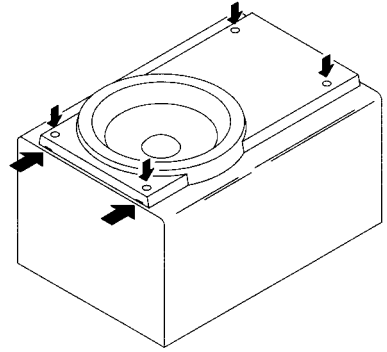

Type.3

Insert a flat-bladed screwdriver into the position indicated by the arrows and remove the panel. Turn the speaker unit to counter-clockwise direction while inserting a flat-bladed screwdriver into one of the hollows around speaker unit, and then remove the speaker unit. After replacing the speaker unit, install it turning to clockwise direction until "click" sound comes out.

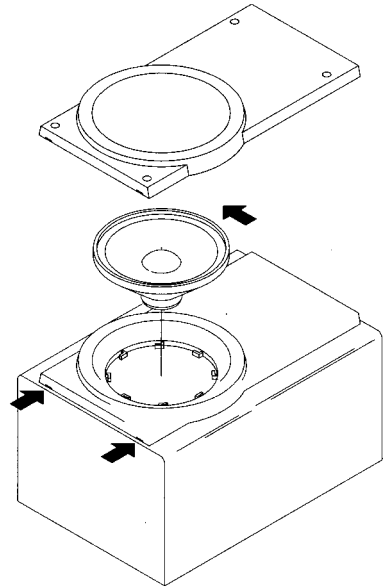

SX-NA10 / NS10 (YU,YJ,YS,YL,ST) SPEAKER PARTS LIST

If can't understand for Description please kindly refer to "REFERENCE NAME LIST".

REF. NO.	PART NO.	KANRI NO.	DESCRIPTION
1	87-NSK-601-019		SPKR, 120
2	86-NSZ-602-019		SPKR, CERA 14
3	87-NSK-001-019		PANEL, FR ST
4	86-NSZ-003-019		NET
5	87-NS7-611-019		CORD, SPKR

REFERENCE NAME LIST

ELECTRICAL SECTION

DESCRIPTION	REFERENCE NAME
ANT	ANTENNAS
C-	CHIP
C-CAP	CAP, CHIP
C-CAP TN	CAP, CHIP TANTALUM
C-COIL	COIL, CHIP
C-DI	DIODE, CHIP
C-DIODE	DIODE, CHIP
C-FET	FET, CHIP
C-FOTR	FILTER, CHIP
C-JACK	JACK, CHIP
C-LED	LED, CHIP
C-RES	RES, CHIP
C-SFR	SFR, CHIP
C-SLIDE SW	SLIDE SWITCH, CHIP
C-SW	SWITCH, CHIP
C-TR	TRANSISTOR, CHIP
C-VR	VOLUME, CHIP
C-ZENER	ZENER, CHIP
CAP, CER	CAP, CERA-SOL
CAP, E	CAP, ELECT
CAP, M/F	CAP, FILM
CAP, TC	CAP, CERA-SOL
CAP, TC-U	CAP, CERA-SOL SS
CAP, TN	CAP, TANTALUM
CERA FIL	FILTER, CERAMIC
CF	FILTER, CERAMIC
DL	DELAY LINE
E/CAP	CAP, ELECT
FILT	FILTER
FLTR	FILTER
FUSE RES	RES, FUSE
MOT	MOTOR
P-DIODE	PHOTO DIODE
P-SNSR	PHOTO SENSER
P-TR	PHOTO TRANSISTOR
POLY VARI	VARIABLE CAPACITOR
PPCAP	CAP, PP
PT	POWER TRANSFORMER
PTR, RES	PTR, MELF
RC	REMOTE CONTROLLER
RES NF	RES, NON-FLAMMABLE
RESO	RESONATOR
SHLD	SHIELD
SOL	SOLENOID
SPKR	SPEAKER
SW, LVR	SWITCH, LEVER
SW, RTRY	SWITCH, ROTARY
SW, SL	SWITCH, SLIDE
TC CAP	CAP, CERA-SOL
THMS	THERMISTOR
TR	TRANSISTOR
TRIMER	CAP, TRIMMER
TUN-CAP	VARIABLE CAPACITOR
VIB, CER	RESONATOR, CERAMIC
VIB, XTAL	RESONATOR, CRYSTAL
VR	VOLUME
ZENER	DIODE, ZENER
サージサプレッサ	SERGE SUPPRESSOR
セラコン	CAP, CERA
	SERGESUPPRESSOR
	CAP,CERA

MECHANICAL SECTION

DESCRIPTION	REFERENCE NAME
ADHESHIVE	SHEET ADHESHIVE
AZ	AZIMUTH
BAR-ANT	BAR-ANTENNA
BAT	BATTERY
BATT	BATTERY
BRG	BEARING
BTN	BUTTON
CAB	CABINET
CASS	CASSETTE
CHAS	CHASSIS
CLR	COLLAR
CONT	CONTROL
CRSR	CURSOR
CU	CUSHION
CUSH	CUSHION
DIR	DIRECTION
DUBB	DUBBING
FL	FRONT LOADING
FLY-WHL	FLYWHEEL
FR	FRONT
FUN	FUNCTION
G-CU	G-CUSHION
HDL	HANDOL
HIMERON	CLOTH
HINGE, BAT	HINGE, BATTERY
HLDR	HOLDER
HT-SINK	HEAT SINK
IB	INSTRUCTION BOOKLET
IDLE	IDLER
IND, L-R	INDICATOR, L-R
KEY, CONT	KEY, CONTROL
KEY, PRGM	KEY, PROGRAM
KNOB, SL	KNOB, SLIDE
LBL	LABEL
LID, BATT	LID, BATTERY
LID, CASS	LID, CASSETTE
LVR	LEVER
P-SP	P-SPRING
PANEL, CONT	PANEL, CONTROL
PANEL, FR	PANEL, FRONT
PRGM	PROGRAM
PULLY, LOAD MO	PULLY, LOAD MOTOR
RBN	RIBBON
S-	SPECIAL
SEG	SEGMENT
SH	SHEET
SHLD-SH	SHIELD-SHEET
SL	SLIDE
SP	SPRING
SP-SCREW	SPECIAL-SCREW
SPACER, BAT	SPACER, BATTERY
SPR	SPRING
SPR-P	P-SPRING
SPR-PC-PUSH	P-SPRING, C-PUSH
T-SP	T-SPRING
TERM	TERMINAL
TRIG	TRIGGER
TUN	TUNING
VOL	VOLUME
W	WASHER
WHL	WHEEL
WORM-WHL	WORM-WHEEL
ジグアーム	ARM, SHAFT
ジグガイド	GUIDE, SHAFT
ストラップ	STRAP
トクナベ	S-SCREW
ヒンジ	HINGE
ヒンジビス	S-SCREW
ビスセレート	SCREW, SERRART

サービス技術ニュース	
番号	連絡内容
G-	-
G-	-
G-	-

AIWA CO.,LTD.

9620450, 750038

Tokyo Japan