

aiwa

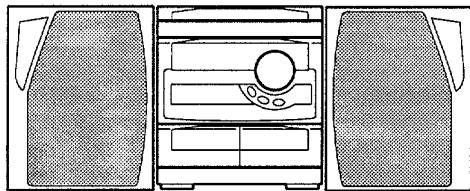

NSX-S22 NSX-S23 XG-S22



COMPACT DISC STEREO
CASSETTE RECEIVER

- BASIC TAPE MECHANISM : 6ZM-3 PR1NM
- BASIC CD MECHANISM : 4ZG-1 Z1DNM, Z1MDNM
- TYPE: S22: HR,D,EZ,K,G,V
S23: EZ

製品コード : 87NY8 - 0193 (ST)

REVISION PUBLISHING

SYSTEM	CD-CASSEIVER	SPEAKER	REMOTE CONTROLLER
NSX-S22 (EZ,K,G,V,HR)	CX-NS22	SX-NS22	RC-6AS14
NSX-S23 (EZ)	CX-NS23		
XG-S22 (D)	CX-NS22		

- This Service Manual is the "Revision Publishing (EZ)" and replaces "Simple Manual NSX-S22/S23 (EZ)" (S/M Code No. 09-977-214-8FE).
- このサービスマニュアルはシンプル版 NSX-S22/S23 (EZ) (S/M Code No. 09-977-214-8FE) の改定版 (EZ) です。差し替えて使用してください。
- If requiring information about the CD mechanism, see service manual of 4ZG-1. (S/M Code No. 09-974-187-50T).
- このサービスマニュアルにはCDメカニズムの説明は含まれていません。CDメカニズムについては、4ZG-1, S/M Code No. 09-974-187-50T のマニュアルを参照してください。

S/M Code No. 09-978-215-8FE

MANUAL
SERVICE

TABLE OF CONTENTS

SPECIFICATIONS <22EZ, K, G, V, HR, 23EZ>	3
SPECIFICATIONS <D>	4
安全に修理（補修）をするために	5
PROTECTION OF EYES FROM LASER BEAM DURING SERVICING	6
PRECAUTION TO REPLACE OPTICAL BLOCK / 光学ブロック(KSS-213B)交換時の注意	6
ELECTRICAL MAIN PARTS LIST	7~10
TRANSISTOR ILLUSTRATION	10
BLOCK DIAGRAM - 1 (MAIN / FRONT : HR, D, 22EZ, K, G, V)	11,12
BLOCK DIAGRAM - 2 (MAIN / FRONT : 23EZ)	13,14
WIRING - 1 (MAIN : HR)	15,16
SCHEMATIC DIAGRAM - 1 (MAIN : HR)	17~19
SCHEMATIC DIAGRAM - 2 (MAIN : D)	20~22
WIRING - 2 (MAIN : D)	23,24
WIRING - 3 (MAIN : 22EZ, K, G, V)	25,26
SCHEMATIC DIAGRAM - 3 (MAIN : 22EZ, K, G, V)	27~29
SCHEMATIC DIAGRAM - 4 (MAIN : 23EZ)	30~32
WIRING - 4 (MAIN : 23EZ)	33,34
WIRING - 5 (FRONT : HR, D, 22EZ, K, G, V)	35,36
SCHEMATIC DIAGRAM - 5 (FRONT : HR, D, 22EZ, K, G, V)	37,38
WIRING - 6 (FRONT : 23EZ)	39,40
SCHEMATIC DIAGRAM - 6 (FRONT : 23EZ)	41,42
WIRING - 7 (AC1 / AC2 : HR, D)	43
WIRING - 8 (AC1 / AC2 : 22EZ, K, G, V, 23EZ)	44
WIRING - 9 (DECK)	45
FL(7BT-185GK) GRID ASSIGNMENT & ANODE CONNECTION	46
FL(10BT183GK) GRID ASSIGNMENT & ANODE CONNECTION	47
IC DESCRIPTION <22EZ, K, G, V, HR, 23EZ>	48~52
IC DESCRIPTION <D>	53~55
IC BLOCK DIAGRAM	56~58
ADJUSTMENT <TUNER / DECK : 22EZ, 23EZ, K, G, V, HR>	59~61
ADJUSTMENT <TUNER / DECK : D>	62,63
PRACTICAL SERVICE FIGURE	64
MECHANICAL EXPLODED VIEW 1 / 1	65,66
MECHANICAL PARTS LIST 1 / 1	67
TAPE MECHANISM EXPLODED VIEW 1 / 1	68,69
TAPE MECHANISM PARTS LIST 1 / 1	70
SPRING APPLICATION POSITION	71
SPEAKER DISASSEMBLY INSTRUCTION	72
SPEAKER PART LIST	73
ACCESSORIES / PACKAGE LIST	73
REFERENCE NAME LIST	74

SPECIFICATIONS (22EZ, K, G, V, HR, 23EZ)

<FM Tuner section>		<Cassette deck section>	
Tuning range	V: FM1 (OIRT) 65 MHz to 74 MHz (10 kHz step) FM2 (CCIR) 87.5 MHz to 108 MHz (50 kHz step) Except V: 87.5 MHz to 108 MHz	Track format	4 tracks, 2 channels stereo
	HR: 13.2 dBf	Frequency response	50 Hz -10000 Hz
	V: FM1: 15.3 dBf, FM2: 12.8 dBf	Recording system	AC bias
	Except HR,V: 16.8 dBf	Heads	Deck 1 : Playback head x1 Deck 2 : Recording/playback head x1, erase head x 1
Usable sensitivity (IHF)		<Compact disc player section>	
		Laser	Semiconductor laser ($\lambda = 780$ nm)
		D-A converter	1 bit dual
Antenna terminals	V: Wire antenna	Signal-to-noise ratio	85 dB (1 kHz, 0 dB)
	Except V: 75 ohms (unbalanced)	Harmonic distortion	0.05 % (1 kHz, 0 dB)
		Wow and flutter	Unmeasurable
<MW Tuner section>		<Speaker system SX-NS22>	
Tuning range	531 kHz to 1602 kHz (9 kHz step) 530 kHz to 1710 kHz (10 kHz step)	Cabinet type	2 way, bass reflex (magnetic shielded type)
Usable sensitivity	350 μ V/m	Speakers	Woofer : 120 mm cone type Tweeter : 10 mm ceramic type
Antenna	Loop antenna	Impedance	6 ohms
<LW Tuner section (except HR)>		Output sound pressure level	87 dB/W/m
Tuning range	144 kHz to 290 kHz	Dimensions (W x H x D)	240 x 304 x 250 mm
Usable sensitivity	1400 μ V/m	Weight	2.7 kg
Antenna	Loop antenna	<General>	
<SW Tuner section (HR)>		Power requirements	HR: 120 V/220 - 240 V AC, switch 50/60 Hz Except HR: 230 V AC, 50 Hz
Tuning range	5.9 MHz ~ 17.900 MHz	Power consumption	HR: 92 W Except HR: 70 W
Antenna	Wire antenna	Dimensions of main unit (W x H x D)	260 x 308.3 x 350 mm
<Amplifier section>		Weight of main unit	HR: 5.8 Kg Except HR: 5.2 Kg
Power output	HR: Rated: 32 W + 32 W (6 ohms, T.H.D 1 %, 1 kHz) V: Rated: 20 W + 20 W (6 ohms, T.H.D 1 %, 1 kHz) Except HR,V: Rated: 20 W + 20 W (6 ohms, T.H.D 1 %, 1 kHz/DIN 45500) HR: Reference: 40 W + 40 W (6 ohms, T.H.D 10 %, 1 kHz) 22EZ: Reference: 24 W + 24 W (6 ohms, T.H.D 10 %, 1 kHz/DIN 45324) 23EZ, K, G: Reference: 25 W + 25 W (6 ohms, T.H.D 10 %, 1 kHz/DIN 45324) Except HR,V: DIN MUSIC POWER: 55 W + 55W	• Design and specifications are subject to change without notice.	
Total harmonic distortion	23EZ: 0.3 % (10 W, 1 kHz, 6 ohms, DIN AUDIO) Except 23EZ: 0.2 % (10 W, 1 kHz, 6 ohms, DIN AUDIO)		
Inputs	VIDEO/AUX: 400 mV HR only: MIC: 1.7 mV (10 kohms) SPEAKERS: accept speakers of 6 ohms or more PHONES (stereo jack) : accepts headphones of 32 ohms or more		
Outputs			

SPECIFICATIONS (D)

チューナー部

<FM部>

受信周波数： 76MHz - 108MHz
アンテナ： ワイヤアンテナ

<AM部>

受信周波数： 531kHz - 1602kHz
アンテナ： ループアンテナ

<タイマー部>

プログラムタイマー： オンタイマー、任意に設定可
スリープタイマー： 5分単位で設定可、最大240分
時計表示： 12時間/24時間表示

アンプ部

定格出力： 20W + 20W (1kHz, 6Ω, 10%) EIAJ
入力端子： VIDEO/AUX 端子 400mV
出力端子： SPEAKERS 端子 6Ω
PHONES 端子 32Ω

カセットデッキ部

トラック方式： 4トラック2チャンネル
周波数特性： ノーマルポジションテープ 50 - 10000Hz

CDプレーヤー部

ディスク： コンパクトディスク
読み取り方式： 非接触光学式読み取り(半導体レーザー使用)
復号化： 1bitデュアル
ワウフラッター： 測定限界以下

共通部

電源： AC100V、50/60Hz
消費電力： 42W
本体最大外形寸法： 260(幅) × 308.3(高) × 350(奥行) mm
本体質量： 4.8Kg

スピーカー SX-NS22

型式： 2ウェイバスレフタイプ(防磁型：EIAJ)
インピーダンス： 6Ω
出力音圧レベル： 87dB/W/m
使用スピーカー： ウーハー120mm ツイーター10mm
最大外形寸法： 240(幅) × 304(高) × 250(奥行) mm
質量： 2.7Kg

・外観及び仕様は予告なく変更する場合があります。

安全に修理(補修)をするために

修理の前に「安全に修理(補修)をするために」をよくお読みの上、正しく修理を行ってください。このサービスマニュアルでは、お客様が製品を安全に正しくお使いいただき、お客様や他の人々への危害や財産への損害を未然に防止するために、修理する場合必ず下記の項目をお守りください。

⚠ 警告

警告に示された次の内容を必ずお守りください。

もし守られないと、火災や感電、けがなどの重度の損害を負う原因となります。

1. ⚠安全規格部品注意文

- ・製品の安全性を維持する為の重要部品で、安全上特別な規格で作られています。このマークの部品を交換する時は必ず指定の部品を使用してください。

内部には高電圧の部分がありますので通電時の取り扱いに際しては注意してください。

2. 指定部品を使用すること。

セットの部品は難燃性や耐電圧など安全上の特性を持ったものとなっています。従って交換部品は、使用されていたものと同じ特性の部品を使用すること。特に回路図、部品表に△印で指定されている安全上重要な部品は必ず指定のものをご使用ください。

5. 次の各項目は修理前と必ず同じであること。

- 1) ワイヤーの半田付け状態（特にAC1次側の空間距離）
- 2) ワイヤーの引き直しおよび束線状態等
- 3) ワイヤーの種類
- 4) 各種絶縁物の取付状態

3. 電源コードを含むAC1次側のリード線の被覆を傷つけたり、溶かしたりしないこと。

7. 部品の取り付けや配線の引き直しはもとどおりにすること。

安全上、チューブやテープなどの絶縁材料を使用したり、プリント基板から浮かしてとりつけた部品があります。また、内部配線は引き直しやクランパーによって発熱部品や高圧部品に接近しないよう配慮されていますので、これらは必ずもとどおりにすること。

4. 感電に注意すること。

⚠ 注意

この表示を無視して、誤った取り扱いをすると、人が傷害を負ったり物的損害が発生する可能性があります。

1. 注意事項を守ること。

サービスの時特に注意を要する箇所につきましては、キャビネット、シャーシ、部品などにラベルや捺印で注意事項を表示しています。これらの注意書きおよび取扱説明書等の注意事項を必ず守ること。

4. サービス後は安全点検すること。

サービスのために取り外したネジ、部品、配線がもとどおりになっているか、サービスした個所の周辺を劣化させてしまったところがないかなどを点検すること。（ワイヤーの半田付け、引き直し、束線、種類、空間距離）

2. スペック銘板・注意ラベル・ヒューズラベル等の表示文字を汚して読みにくくならないこと。

3. 基板パターンの裏付け部品の修理等を行う場合、パターンや部品にボンドを塗布してプリント基板にしっかり固定すること。

5. 修理（補修）時に、レーザー出力部に接近しないでください。やむなく接近する場合は、目を閉じてください。レーザービームに接近することが必要になった場合、光学ピックアップブロックの対物レンズの表面から30cm以上離れていることを確認してください。

PROTECTION OF EYES FROM LASER BEAM DURING SERVICING

This set employs laser. Therefore, be sure to follow carefully the instructions below when servicing.

WARNING!!

WHEN SERVICING, DO NOT APPROACH THE LASER EXIT WITH THE EYE TOO CLOSELY. IN CASE IT IS NECESSARY TO CONFIRM LASER BEAM EMISSION. BE SURE TO OBSERVE FROM A DISTANCE OF MORE THAN 30cm FROM THE SURFACE OF THE OBJECTIVE LENS ON THE OPTICAL PICK-UP BLOCK.

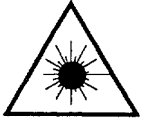

- Caution: Invisible laser radiation when open and interlocks defeated avoid exposure to beam.
- Advarsel: Usynlig laserstråling ved åbning, når sikkerhedsafbrydere er ude af funktion. Undgå udsættelse for stråling.

VAROITUS!

Laiteen Käyttäminen muulla kuin tässä käyttöohjeessa mainitulla tavalla saattaa altistaa käyttäjän turvallisuusluokan 1 ylitävälle näkymättömälle lasersäteilylle.

VARNING!

Om apparaten används på annat sätt än vad som specificeras i denna bruksanvisning, kan användaren utsättas för osynlig laserstrålning, som överskrider gränsen för laserklass 1.

CAUTION

Use of controls or adjustments or performance of procedures other than those specified herein may result in hazardous radiation exposure.

ATTENTION

L'utilisation de commandes, réglages ou procédures autres que ceux spécifiés peut entraîner une dangereuse exposition aux radiations.

ADVARSEL!

Usynlig laserstråling ved åbning, når sikkerhedsafbrydere er ude af funktion. Undgå udsættelse for stråling.

This Compact Disc player is classified as a CLASS 1 LASER product.

The CLASS 1 LASER PRODUCT label is located on the rear exterior.

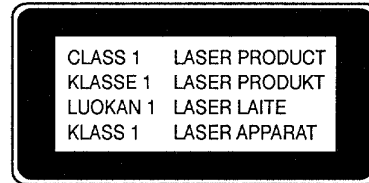

Precaution to replace Optical block (KSS – 213B)

光学ブロック (KSS-213B) 交換時の注意

Body or clothes electrostatic potential could ruin laser diode in the optical block. Be sure ground body and workbench, and use care the clothes do not touch the diode.

- 1) After the connection, remove solder shown in figure below.

光学系ブロック内のレーザーダイオードは、衣服や人体に帯電した静電荷等で電位差を生じることにより、静電破壊することがあります。人体アース、作業台のアースをとり、衣服が触れぬよう注意して下さい。

- 1) コネクターを接続後、右図に示すハンダ付けを取り除いて下さい。

PICK-UP Assy P.C.B

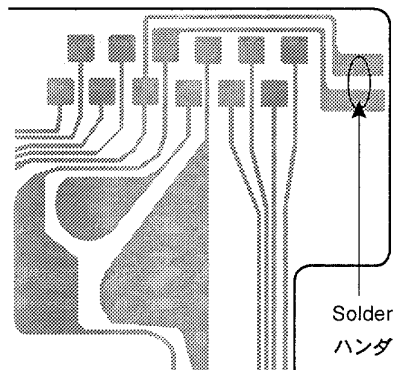

ELECTRICAL MAIN PARTS LIST

If can't understand for Description please kindly refer to "REFERENCE NAME LIST".

REF. NO.	PART NO.	KANRI NO.	DESCRIPTION	REF. NO.	PART NO.	KANRI NO.	DESCRIPTION
IC				C106	87-010-260-080		CAP, ELECT 47-25V<NS23EZ>
				C106	87-010-408-080	0E	CAP, ELECT 47-50V<EXCEPT NS23EZ>
	87-020-454-010	1A	IC, DN6851	C107	87-010-384-080	0E	CAP, ELECT 100-25V<EXCEPT NS23EZ>
	87-NF8-610-010	--	C-IC, UPD78044HGF-026-3B9<EX NS23EZ>	C107	87-010-101-080		CAP, ELECT 220-16<NS23EZ>
	87-NF8-611-010	--	C-IC, UPD78046HGF-017-3B9<NS23EZ>	C108	87-010-381-080	0E	CAP, ELECT 330-16V<EXCEPT HR>
	87-NF8-619-010	--	IC, SPS-442-1-A				
	86-NFZ-642-010	--	IC, NJM4558LD	C108	87-010-386-080		CAP, E330-25 SME<HR>
				C109	87-010-383-080		CAP, ELECT 33-25V<HR>
	87-017-804-010	1B	IC, BU4052BCP	C109	87-010-260-080	0E	CAP, ELECT 47-25V<EXCEPT HR>
	87-NF8-612-010	--	IC, M62420SPL	C110	87-010-383-080		CAP, ELECT 33-25V<HR>
	87-017-914-010		IC, BU4094 BCP<NS23EZ>	C110	87-010-260-080	0E	CAP, ELECT 47-25V<EXCEPT HR>
	87-NF8-618-010	--	IC, LC72131(L)				
	87-002-641-010	--	IC, TA8124P<D>	C111	87-010-247-080	0E	CAP, ELECT 100-50V
				C112	87-010-263-080	0E	CAP, ELECT 100-10V
	87-NF8-617-010	--	IC, LA1836(L)	C113	87-010-403-080	0E	CAP, ELECT 3.3-50V
	87-A20-502-010		IC, BU1920<NS23EZ>	C114	87-010-374-080	--	CAP, ELECT 47-10V
	87-017-300-010		IC, NJM2100L<NS23EZ>	C118	87-018-134-080	0E	CAPACITOR, TC-U 0.01-16<HR, D>
TRANSISTOR				C151	87-018-134-080		CAPACITOR, TC-U 0.01-16<NS23EZ>
	87-026-463-080	0E	TR, 2SA933SRS	C201	87-010-401-080	0E	CAP, ELECT 1-50V
	89-213-702-010	1A	TR, 2SB1370 (1.8W)	C202	87-010-401-080	0E	CAP, ELECT 1-50V
	89-333-317-080	--	TR, 2SC3331 (0.5W)	C203	87-018-199-080	--	CAP, CER 3300P<EXCEPT HR>
	86-NFZ-659-080		TR, 2SC3266GR<NS23EZ>	C203	87-018-202-080		CAP, CERAM.6800PF<HR>
	87-A30-083-080	0E	TR, CSD1489B	C204	87-018-199-080	--	CAP, CER 3300P<EXCEPT HR>
				C204	87-018-202-080		CAP, CERAM.6800PF<HR>
	87-026-245-080	--	TR, DTC114ES	C205	87-018-196-080		CAP, CER 1500P-16V<NS23EZ>
	89-113-187-080	0E	TR, 2SA1318TU	C206	87-018-196-080		CAP, CER 1500P-16V<NS23EZ>
	89-109-521-080	0E	TR, 2SA952 (0.6W)	C207	87-010-545-080		CAP, ELECT 0.22-50V<NS23EZ>
	87-A30-084-080	0E	TR, CSB1058B	C207	87-010-260-080	0E	CAP, ELECT 47-25V<EXCEPT NS23EZ>
	86-NFZ-656-080	--	TR, 2SA1175F	C208	87-010-545-080		CAP, ELECT 0.22-50V<NS23EZ>
				C208	87-010-260-080	0E	CAP, ELECT 47-25V<EXCEPT NS23EZ>
	87-A30-090-080		FET, 2SK2541<NS23EZ>	C209	87-010-221-080		CAP, ELECT 470-10V<NS23EZ>
	86-NFZ-648-080	--	TR, DTA143ESA	C210	87-010-221-080		CAP, ELECT 470-10V<NS23EZ>
	87-026-269-080		TR, DTA114ES<EXCEPT D>				
	86-NFZ-703-080		TR, 2SC2002LK<NS23EZ>	C211	87-018-115-080		CAP, CER 47P-50V<NS23EZ>
	86-NFZ-704-080		TR, 2SA953LK<NS23EZ>	C211	87-010-374-080	--	CAP, ELECT 47-10V<EXCEPT NS23EZ>
				C212	87-018-115-080		CAP, CER 47P-50V<NS23EZ>
	87-A30-112-080	--	TR, C2N5551<EXCEPT NS23EZ>	C212	87-010-374-080	--	CAP, ELECT 47-10V<EXCEPT NS23EZ>
	87-A30-109-010	--	TR, 2SD 2495<EXCEPT NS23EZ>	C213	87-010-260-080	0E	CAP, ELECT 47-25V<EXCEPT NS23EZ>
	89-420-612-010		TR, 2SD2061 (2W)<NS23EZ>				
	87-A30-108-010	--	TR, 2SB1626<EXCEPT NS23EZ>	C213	87-018-104-080		CAP, TC-U 10P-50 SL<NS23EZ>
	87-A30-047-080	--	TR, CSD655E	C214	87-010-260-080	0E	CAP, ELECT 47-25V<EXCEPT NS23EZ>
				C214	87-018-104-080		CAP, TC-U 10P-50 SL<NS23EZ>
	86-NFZ-647-080	--	TR, DTC144ESA	C219	87-010-544-080	--	CAP, ELECT 0.1-50V
	86-NFZ-650-080	--	TR, DTA144WSA	C220	87-010-544-080	--	CAP, ELECT 0.1-50V
	86-NFZ-649-080	--	TR, DTC143XSA				
	87-026-219-080	--	TR, DTA144ES (0.3W)<D>	C221	87-018-134-080		CAPACITOR, TC-U 0.01-16<EXCEPT HR, D>
	86-NFZ-645-080	--	TR, DTA114YSA	C222	87-018-134-080		CAPACITOR, TC-U 0.01-16<EXCEPT HR, D>
				C223	87-018-134-080		CAPACITOR, TC-U 0.01-16<NS23EZ>
	87-026-215-080	--	TR, DTC114YS<D, NS23EZ>	C225	87-010-394-080		CAP ELECT 220-35V<NS23EZ>
	87-A30-092-080	--	FET, 2SK439E/F	C226	87-010-408-080		CAP, ELECT 47-50V<NS23EZ>
	89-305-352-380	--	TR, 2SC535(B/C)				
	86-NFZ-657-080	--	TR, 2SC19230<HR, D>	C227	87-010-405-080		CAP, ELECT 10-50V<NS23EZ>
	87-026-462-080		TR, 2SC1740 S(RS 0.3W)<HR>	C227	87-010-260-080	0E	CAP, ELECT 47-25V<EXCEPT NS23EZ>
				C229	87-018-113-080	--	CAP, CER 33P-50V<EXCEPT NS23EZ>
	89-320-011-080		TR, 2SC2001 (15W)<EXCEPT D>	C230	87-018-113-080	--	CAP, CER 33P-50V<EXCEPT NS23EZ>
				C232	87-018-115-080		CAP, CER 47P-50V<G, K, NS22EZ, V>
DIODE				C233	87-018-115-080		CAP, CER 47P-50V<G, K, NS22EZ, V>
	87-070-178-090	--	DIODE, 1N5402-BD54	C243	87-018-209-080		CAP, CER 0.1-50V<G, K, NS22EZ, V>
	87-070-274-080	0E	DIODE, 1N4003 SEM	C244	87-018-134-080		CAPACITOR, TC-U 0.01-16<G, K, NS22EZ, V>
	87-A40-236-080	--	ZENER, MTZJ24D	C250	87-018-134-080		CAPACITOR, TC-U 0.01-16<G, K, NS22EZ, V>
	87-A40-246-080	0E	DIODE, 1N4148 T-72	C255	87-018-134-080		CAPACITOR, TC-U 0.01-16<NS23EZ>
	87-017-933-080	--	ZENER, MTZJ10D				
				C292	87-018-134-080		CAPACITOR, TC-U 0.01-16<NS23EZ>
	87-017-932-080	0E	ZENER, MTJ6.2B	C301	87-018-195-080	--	CAP, CER 1200P-16V<EXCEPT NS23EZ>
	87-002-843-080		DIODE, 1SS108<NS23EZ>	C301	87-018-196-080		CAP, CER 1500P-16V<NS23EZ>
	87-A40-235-080	--	ZENER, MTZJ9.1C	C302	87-018-195-080	--	CAP, CER 1200P-16V<EXCEPT NS23EZ>
	87-A40-234-080	--	ZENER, MTZJ5.6A	C302	87-018-196-080		CAP, CER 1500P-16V<NS23EZ>
	87-017-437-080	0E	DIODE, 1N4148M				
MAIN C.B				C303	87-010-263-080	0E	CAP, ELECT 100-10V
	C102	87-A10-520-090	1B CAP, E 3300-35 M SMG<EXCEPT HR>	C304	87-010-263-080	0E	CAP, ELECT 100-10V
	C102	87-016-055-090	CAP, E 3300-42 HI-R<HR>	C309	87-010-546-080	--	CAP, ELECT 0.33-50V
	C103	87-016-051-090	-- CAP, E 2200-35 SMG<EXCEPT HR>	C310	87-010-546-080	--	CAP, ELECT 0.33-50V
	C103	87-A10-627-090	CAP, E 2200-50 M SMG<HR>	C311	87-018-130-080	--	CAP, TC-U 820P-50 B
	C105	87-018-127-080	-- CAP, CER 470P-50V				
				C312	87-018-130-080	--	CAP, TC-U 820P-50 B
				C314	87-010-260-080	0E	CAP, ELECT 47-25V
				C345	87-018-115-080		CAP, CER 47P-50V<EXCEPT HR, D>
				C346	87-018-115-080		CAP, CER 47P-50V<G, K, NS22EZ, V>
				C349	87-018-209-080		CAP, CER 0.1-50V<EXCEPT HR, D>

REF. NO.	PART NO.	KANRI NO.	DESCRIPTION	REF. NO.	PART NO.	KANRI NO.	DESCRIPTION
C351	87-018-131-080	--	CAP, CER 1000P-50V	C775	87-010-405-080	0E	CAP, ELECT 10-50V
C352	87-018-131-080	--	CAP, CER 1000P-50V	C777	87-010-400-080	0E	CAP, ELECT 0.47-50V
C353	87-010-263-080	0E	CAP, ELECT 100-10V	C778	87-010-401-080	0E	CAP, ELECT 1-50V
C354	87-010-263-080	0E	CAP, ELECT 100-10V	C779	87-010-401-080	0E	CAP, ELECT 1-50V
C360	87-010-370-080	0E	CAP, E 330-6.3 SME	C781	87-010-402-080	0E	CAP, ELECT 2.2-50V<D>
C365	87-018-134-080		CAPACITOR,TC-U 0.01-16<NS23EZ>	C782	87-010-402-080	0E	CAP, ELECT 2.2-50V<D>
C390	87-018-209-080		CAP, CER 0.1-50V<EXCEPT HR,D>	C783	87-018-208-080	--	CAP 0.047-50F<D>
C391	87-018-115-080		CAP, CER 47P-50V<EXCEPT HR,D>	C784	87-018-208-080	--	CAP 0.047-50F<D>
C392	87-018-115-080		CAP, CER 47P-50V<G,K,NS22EZ,V>	C791	87-010-401-080	0E	CAP, ELECT 1-50V
C395	87-018-134-080		CAPACITOR,TC-U 0.01-16 <G,K,NS22EZ,V>	C792	87-018-196-080	--	CAP, CER 1500P-16V<HR,D,V>
C398	87-018-134-080		CAPACITOR,TC-U 0.01-16 <G,K,NS22EZ,V>	C792	87-018-132-080		CAP, CER 2200P-16V<EX HR,D,V>
C399	87-018-209-080		CAP, CER 0.1-50V<G,K,NS22EZ,V>	C794	87-010-260-080	0E	CAP, ELECT 47-25V
C401	87-010-401-080	0E	CAP, ELECT 1-50V	C795	87-018-208-080		CAP 0.047-50F<EXCEPT HR,D>
C402	87-010-401-080	0E	CAP, ELECT 1-50V	C796	87-010-403-080	0E	CAP, ELECT 3.3-50V
C403	87-018-118-080	--	CAP,TC-U 82P-50 B	C799	87-010-405-080	0E	CAP, ELECT 10-50V
C404	87-018-118-080	--	CAP,TC-U 82P-50 B	C801	87-018-102-080	--	CAP,TC-U 6.8P-50 SL<HR,D>
C452	87-010-385-080	--	CAP, ELECT 220-25V	C803	87-018-147-080	--	CAP,TC-U 10P-50 CH<D>
C458	87-018-131-080	--	CAP, CER 1000P-50V	C806	87-018-101-080	--	CAP,TC-U 5.6P-50 SL<HR,D>
C459	87-018-128-080	--	CAP, CERA-SOL SS 560P	C807	87-018-102-080	--	CAP,TC-U 6.8P-50 SL<HR,D>
C461	87-018-126-080	--	CAP,TC-U 390P-50 B	C808	87-018-098-080	--	CAP,TC-U 3.3P-50 SL<HR,D>
C462	87-018-126-080	--	CAP,TC-U 390P-50 B	C809	87-018-119-080	--	CAP, CER 100P-50V<HR,D>
C470	87-018-209-080		CAP, CER 0.1-50V<G,K,NS22EZ,V>	C811	87-018-103-080	--	CAP, CER 8.2P-50V<D>
C471	87-010-400-080	0E	CAP, ELECT 0.47-50V	C811	87-018-107-080		CAP,TC-U 18P-50 SL<HR>
C472	87-010-400-080	0E	CAP, ELECT 0.47-50V	C814	87-010-260-080		CAP, ELECT 47-25V<G,K,NS22EZ,V>
C505	87-010-545-080	0E	CAP, ELECT 0.22-50V<EX NS23EZ>	C815	87-018-134-080		CAPACITOR,TC-U 0.01-16<HR,D>
C506	87-010-545-080	0E	CAP, ELECT 0.22-50V<EX NS23EZ>	C815	87-018-134-080		CAPACITOR,TC-U 0.01-16<NS23EZ>
C510	87-010-405-080	0E	CAP, ELECT 10-50V	C820	87-010-260-080		CAP, ELECT 47-25V<NS23EZ>
C511	87-010-260-080	0E	CAP, ELECT 47-25V	C821	87-018-148-080	--	CAP,TC-U 12P-50 CH<HR,D>
C512	87-010-260-080	0E	CAP, ELECT 47-25V	C821	87-018-134-080		CAPACITOR,TC-U 0.01-16<NS23EZ>
C513	87-010-221-080	--	CAP, ELECT 470-10V	C822	87-018-111-080	--	CAP, CERA-SOL SS 27P<HR,D>
C515	87-010-401-080	0E	CAP, ELECT 1-50V<EXCEPT NS23EZ>	C823	87-018-111-080	--	CAP, CERA-SOL SS 27P<HR,D>
C515	87-016-073-080		CAP,E 1-50 FX<NS23EZ>	C823	87-018-134-080		CAPACITOR,TC-U 0.01-16<NS23EZ>
C516	87-010-401-080	0E	CAP, ELECT 1-50V<EXCEPT NS23EZ>	C824	87-018-109-080		CAP, CER 22P-50V<HR>
C516	87-016-073-080		CAP,E 1-50 FX<NS23EZ>	C824	87-018-100-080	--	CAP, CER 4.7P-50V<D>
C517	87-018-134-080	0E	CAPACITOR,TC-U 0.01-16	C825	87-018-209-080		CAP, CER 0.1-50V<EXCEPT HR,D>
C518	87-018-134-080	0E	CAPACITOR,TC-U 0.01-16	C827	87-018-131-080	--	CAP, CER 1000P-50V<D>
C551	87-018-115-080		CAP, CER 47P-50V<NS23EZ>	C849	87-018-134-080		CAPACITOR,TC-U 0.01-16<EX HR,D>
C552	87-018-115-080		CAP, CER 47P-50V<NS23EZ>	C851	87-018-131-080		CAP, CER 1000P-50V<EXCEPT HR,D>
C553	87-018-115-080		CAP, CER 47P-50V<NS23EZ>	C852	87-018-131-080		CAP, CER 1000P-50V<EXCEPT HR,D>
C701	87-010-404-080	0E	CAP, ELECT 4.7-50V	C853	87-018-134-080		CAPACITOR,TC-U 0.01-16 <G,K,NS22EZ,V>
C704	87-018-131-080		CAP, CER 1000P-50V<EXCEPT HR,D>	C854	87-018-134-080		CAPACITOR,TC-U 0.01-16 <G,K,NS22EZ,V>
C711	87-010-402-080	0E	CAP, ELECT 2.2-50V<EXCEPT NS23EZ>	C861	87-018-131-080		CAP, CER 1000P-50V<NS23EZ>
C711	87-010-260-080		CAP, ELECT 47-25V<NS23EZ>	C862	87-018-132-080		CAP, CER 2200P-16V<NS23EZ>
C712	87-010-112-080	0E	CAP, ELECT 100-16V	C863	87-018-127-080		CAP, CER 470P-50V<NS23EZ>
C722	87-018-149-080	--	CAP,TC-U 15P-50 CH	C864	87-010-405-080		CAP, ELECT 10-50V<NS23EZ>
C728	87-010-248-080	0E	CAP, ELECT 220-10V	C865	87-018-209-080		CAP, CER 0.1-50V<NS23EZ>
C730	87-018-134-080		CAPACITOR,TC-U 0.01-16<NS23EZ>	C866	87-010-405-080		CAP, ELECT 10-50V<NS23EZ>
C733	87-018-148-080	--	CAP,TC-U 12P-50 CH	C867	87-018-134-080		CAPACITOR,TC-U 0.01-16<NS23EZ>
C741	87-010-546-080		CAP, ELECT 0.33-50V<HR>	C868	87-018-111-080		CAP, CERA-SOL SS 27P<NS23EZ>
C741	87-010-401-080	0E	CAP, ELECT 1-50V<EXCEPT HR>	C869	87-018-111-080		CAP, CERA-SOL SS 27P<NS23EZ>
C742	87-010-546-080		CAP, ELECT 0.33-50V<HR>	C903	87-010-401-080	0E	CAP, ELECT 1-50V<HR,D>
C742	87-010-401-080	0E	CAP, ELECT 1-50V<EXCEPT HR>	C941	87-018-107-080		CAP,TC-U 18P-50 SL<HR>
C743	87-010-404-080	0E	CAP, ELECT 4.7-50V<D>	C942	87-018-141-080		CAP, CERA-SOL SS 3.3P CH<EX HR,D>
C744	87-010-260-080	0E	CAP, ELECT 47-25V<D>	C942	87-018-147-080	--	CAP,TC-U 10P-50 CH<D>
C745	87-010-401-080	0E	CAP, ELECT 1-50V<D>	C943	87-018-134-080		CAPACITOR,TC-U 0.01-16<HR>
C746	87-010-401-080	0E	CAP, ELECT 1-50V<D>	C944	87-014-051-080		CAPACITOR (PP), 560P<HR>
C747	87-018-134-080	0E	CAPACITOR,TC-U 0.01-16<D>	C945	87-018-134-080		CAPACITOR,TC-U 0.01-16<HR>
C748	87-018-205-080	--	CAP, CERA-SOL 0.022<D>	C946	87-010-401-080		CAP, ELECT 1-50V<NS23EZ>
C749	87-010-248-080	0E	CAP, ELECT 220-10V<D>	C949	87-014-049-080		CAP,PP 470P-100 J<EXCEPT HR,D>
C752	87-018-107-080	--	CAP,TC-U 18P-50 SL<D>	C950	87-014-073-080		CAP,PP 4700P-100 J<HR>
C753	87-010-402-080	0E	CAP, ELECT 2.2-50V<D>	C952	87-018-134-080		CAPACITOR,TC-U 0.01-16<EXCEPT D>
C754	87-018-147-080	--	CAP,TC-U 10P-50 CH<D>	C953	87-018-134-080		CAPACITOR,TC-U 0.01-16<HR>
C755	87-010-545-080	0E	CAP, ELECT 0.22-50V<D>	C954	87-010-400-080		CAP, ELECT 0.47-50V<HR>
C760	87-010-401-080	0E	CAP, ELECT 1-50V<D>	C954	87-010-401-080		CAP, ELECT 1-50V<G,K,NS22EZ,V>
C761	87-010-401-080	0E	CAP, ELECT 1-50V<D>	C955	87-018-134-080		CAPACITOR,TC-U 0.01-16<EXCEPT D>
C771	87-010-405-080	0E	CAP, ELECT 10-50V	C956	87-010-263-080		CAP, ELECT 100-10V<HR>
C773	87-018-208-080	--	CAP 0.047-50F	C957	87-018-147-080		CAP,TC-U 10P-50 CH<NS23EZ>
C774	87-010-263-080	0E	CAP, ELECT 100-10V	C958	87-018-134-080		CAPACITOR,TC-U 0.01-16<EXCEPT HR,D>

REF. NO.	PART NO.	KANRI NO.	DESCRIPTION	REF. NO.	PART NO.	KANRI NO.	DESCRIPTION
C960	87-018-209-080		CAP, CER 0.1-50V<EXCEPT HR,D>	X703	87-A70-044-010	--	VIB, CER CMU2-456A15
C999	87-018-209-080		CAP, CER 0.1-50V<HR>	X721	86-NFZ-651-010	--	VIB,XTAL 4.500MHZ CSA-309
CF801	87-008-423-080		CF,SFE10.7 MS3G-A<EXCEPT HR,D>	X850	89-KT1-608-010		X,TAL,4.332MHZ<NS23EZ>
CF801	87-008-261-010	1A	FILTER, SFE10.7MA5-A<HR,D>				
CF802	82-785-747-080		CF,MS2 GHY,R<EXCEPT HR,D>				
FRONT C.B							
D801	87-A40-226-080	--	VARI-CAP,SVC251SPA<HR,D>	C101	87-018-205-080	--	CAP, CERA-SOL 0.022
D802	87-A40-226-080	--	VARI-CAP,SVC251SPA<HR,D>	C203	87-010-405-040	0E	CAP,E 10-50
D805	87-A40-226-080	--	VARI-CAP,SVC251SPA<D>	C204	87-A10-586-040	--	CAP,E 47-35 7L SR
FB201	87-008-372-080		FILTER, EMI BL OIRNI<NS23EZ>	C205	87-018-208-080	--	CAP 0.047-50F
FB301	87-008-372-080		FILTER, EMI BL OIRNI <G,K,NS22EZ,V>	C206	87-018-205-080	--	CAP, CERA-SOL 0.022
FB304	87-008-372-080		FILTER, EMI BL OIRNI <G,K,NS22EZ,V>	C207	87-010-544-040	--	CAP,E 0.1-50 SME
FFE801	A8-62A-191-030		6ZA-1 FEENM<EXCEPT HR,D,V>	C208	87-010-263-040	0E	CAP,E 100-10
FFE801	A8-62A-193-030		6ZA-1 FEVNM<V>	C209	87-018-205-080	--	CAP, CERA-SOL 0.022<EX NS23EZ>
J201	87-A60-024-010	1B	JACK 6.3BLK W/S WKM	C210	87-018-208-080	--	CAP 0.047-50F
J201	87-A60-024-010	1B	JACK 6.3BLK W/S WKM	C211	87-A10-189-040	0E	CAP,E 220-10
J202	87-A60-238-010	1A	TERMINAL,SP 4P (MSC)	C212	87-018-208-080	--	CAP 0.047-50F
J203	87-A60-354-010	--	JACK,PIN 2P MSP -242V-05	C213	87-010-494-040	0E	CAP,E 1-50 GAS
J801	87-A60-202-010		TERMINAL,ANT 4P MSP-154V-02<HR>	C215	87-018-149-080	--	CAP,TC-U 15P-50 CH
J802	87-033-241-010		TERMINAL,ANT AJ-2039<EX HR,D,V>	C216	87-018-115-080	--	CAP, CER 47P-50V
L201	87-003-383-010		COIL,1UH-S<EXCEPT HR,D>	C217	87-018-113-080	--	CAP, CER 33P-50V
L202	87-003-383-010		COIL,1UH-S<EXCEPT HR,D>	C218	87-018-205-080	--	CAP, CERA-SOL 0.022
L451	86-NFZ-696-010	--	COIL,OSC 85KHZ BIAS	C220	87-018-127-080	--	CAP, CER 470P-50V
L741	87-A50-015-010	--	COIL,FM DET(TOK)	C221	87-018-205-080	--	CAP, CERA-SOL 0.022
L742	87-A90-245-010		FLTR,CFAZH-450 (TOK)<EX HR,D>	C225	87-018-205-080	--	CAP, CERA-SOL 0.022
L742	87-A90-052-010		FLTR,CFMT-450A(TOK)<HR>	C226	87-018-134-080	0E	CAPACITOR,TC-U 0.01-16
L742	87-A90-053-010	1C	FLTR,PCFMT-060(TOK)<D>	C301	87-010-421-040	--	CAP,E 4.7-50 5L
L750	87-005-165-080	--	COIL,1UH (H,E)<EXCEPT NS23EZ>	C302	87-010-421-040		CAP,E 4.7-50 5L<NS23EZ>
L801	87-A50-110-010		COIL,FM BPF EX<HR>	C302	87-010-404-040	0E	CAP,E 4.7-50 SME<EXCEPT NS23EZ>
L801	87-006-246-010	--	COIL,RF FM 3-1/2T,L4<D>	C304	87-010-421-040	--	CAP,E 4.7-50 5L
L802	87-006-244-010	--	COIL,RF FM 3-1/2T,L4<HR,D>	C305	87-010-421-040		CAP,E 4.7-50 5L<NS23EZ>
L803	87-A50-154-010	--	COIL,FM RF3-3/4T D<D>	C305	87-010-404-040	0E	CAP,E 4.7-50 SME<EXCEPT NS23EZ>
L803	87-006-246-010		COIL,RF FM 3-1/2T,L4<HR>	C402	87-010-545-040		CAP,E 0.22-50 SME<HR>
L804	86-NFZ-694-080	--	COIL,2.2UH K CECS<HR,D>	C403	87-018-118-080		CAP,TC-U 82P-50 B<HR>
L805	87-A50-153-010	--	COIL,FM OSC D<D>	C404	87-010-544-040		CAP,E 0.1-50 SME<HR>
L805	87-A50-111-110		COIL,FM OSC EX<HR>	C406	87-018-130-080		CAP,TC-U 820P-50 B<HR>
L806	86-ZA1-604-110	--	IFT,FM IFT 7-6.2<HR,D>	C409	87-010-248-040		CAP,E 220-10 SME<HR>
L807	86-NFZ-694-080	--	COIL,2.2UH K CECS<HR,D>	C410	87-010-405-040		CAP,E 10-50<HR>
L832	87-003-098-080		COIL,2.2UH<EXCEPT HR,D>	C412	87-010-401-040		CAP,E 1-50 SME<HR>
L850	87-005-847-080		COIL,2.2UH(CECS)<NS23EZ>	FL301	82-NF7-631-010	--	FL 7BT-185GK<EXCEPT NS23EZ>
L901	86-NF4-665-010		AM PACK 1(TOK)<G,K,NS22EZ,V>	FL301	86-NF6-661-010		FL,10BT183GK<NS23EZ>
L901	86-NF4-666-010		AM PACK 3(TOK)<HR>	J401	87-A60-284-010		JACK,3.5MO (MSC)<HR>
L901	86-NFZ-634-110	--	COIL,AM PACK 4(TOK)<D>	S301	87-A90-095-080	0E	SW,TACT EVQ11G04M
L941	87-A50-020-010		COIL,ANT LW(COI)<EXCEPT HR,D>	S302	87-A90-095-080	0E	SW,TACT EVQ11G04M
L941	87-A50-022-010		COIL,ANT SW(COI)<HR>	S303	87-A90-095-080	0E	SW,TACT EVQ11G04M
L942	87-A50-019-010		COIL,OSC LW(COI)<EXCEPT HR,D>	S304	87-A90-095-080	0E	SW,TACT EVQ11G04M
L942	87-A50-021-010		COIL,OSC SW(COI)<HR>	S305	87-A90-095-080	0E	SW,TACT EVQ11G04M
L943	87-005-372-080		COIL S 1MHM<HR>	S306	87-A90-095-080	0E	SW,TACT EVQ11G04M
L944	87-003-131-080		COIL, 10MH<HR>	S307	87-A90-095-080	0E	SW,TACT EVQ11G04M
L981	86-NF4-665-010		AM PACK 1(TOK)<NS23EZ>	S308	87-A90-095-080	0E	SW,TACT EVQ11G04M
△ PR201	87-026-681-080		PROTECTOR,5A 60V 491<NS23EZ>	S309	87-A90-095-080	0E	SW,TACT EVQ11G04M
△ PR202	87-026-681-080	--	PROTECTOR,5A 60V 491<EX NS23EZ>	S310	87-A90-095-080	0E	SW,TACT EVQ11G04M
△ PR401	87-035-515-080	--	FUSE,1/4A 125V D/U/C<D>	S311	87-A90-095-080	0E	SW,TACT EVQ11G04M
△ PR401	87-A90-246-080		PROTECTOR,0.25A 60 4<EXCEPT D>	S312	87-A90-095-080	0E	SW,TACT EVQ11G04M
R223	87-A00-258-080	--	RES,M/F 0.22-1W J<EX NS23EZ>	S313	87-A90-095-080	0E	SW,TACT EVQ11G04M
R224	87-A00-258-080	--	RES,M/F 0.22-1W J<EX NS23EZ>	S314	87-A90-095-080	0E	SW,TACT EVQ11G04M
R245	87-022-050-080		RESISTOR, 1W 0.22J<NS23EZ>	S315	87-A90-095-080	0E	SW,TACT EVQ11G04M
R246	87-022-050-080		RESISTOR, 1W 0.22J<NS23EZ>	S316	87-A90-095-080	0E	SW,TACT EVQ11G04M
R507	81-583-677-080	--	RES,NF 120-1/4W J<D,NS23EZ>	S317	87-A90-095-080	0E	SW,TACT EVQ11G04M
SFR451	87-A90-432-080	--	SFR,30K H NVZ6TLTA<EX NS23EZ>	S318	87-A90-095-080	0E	SW,TACT EVQ11G04M
SFR451	86-NFZ-644-080		SFR,33K H RH0638C<NS23EZ>	S319	87-A90-095-080	0E	SW,TACT EVQ11G04M
SFR452	87-A90-432-080	--	SFR,30K H NVZ6TLTA<EX NS23EZ>	S320	87-A90-095-080	0E	SW,TACT EVQ11G04M
SFR452	86-NFZ-644-080		SFR,33K H RH0638C<NS23EZ>	S321	87-A90-095-080	0E	SW,TACT EVQ11G04M
SFR722	87-A90-500-080	--	SPR,10K H NVZ6TLTA	S322	87-A90-095-080		SW,TACT EVQ11G04M<NS23EZ>
TC941	87-011-221-080		CAP, TRIMMER 30P<G,K,NS22EZ,V>	S323	87-A90-095-080		SW,TACT EVQ11G04M<NS23EZ>
TC941	87-011-220-080		TRIMMER CAP 20P VTC<HR>	S324	87-A90-095-080		SW,TACT EVQ11G04M<NS23EZ>
TC942	87-011-221-080		CAP, TRIMMER 30P<HR,NS23EZ>	SW201	87-NF8-616-010	--	SW,RTRY REB161(W/O NUT)
W101	83-NE2-618-110	--	F-CABEL,5P-2.5	VR401	87-NB7-602-010		VR,RTRY 10KAX1 1 V<HR>
W102	88-906-171-110	--	FF-CABLE,6P 1.25	W103	86-NFZ-637-010	--	FF-CABLE, 13P CD
X702	87-030-283-010	--	VIB,CER CSA3.60MGF N<D>	W104	88-911-091-110	--	FF-CABLE,11P 1.25

REF. NO.	PART NO.	KANRI NO.	DESCRIPTION
X201	87-A70-075-080	--	VIB,CER 4.19MHZ CRHF
AC2 C.B			
C100	87-018-134-080		CAPACITOR,TC-U 0.01-16<EX HR,D,V>
AC1 C.B			
▲ CL1	87-033-213-080		CLAMP, FUSE<NS23EZ>
▲ CL2	87-033-213-080		CLAMP, FUSE<NS23EZ>
▲ FC1	87-A90-505-080	--	FUSE CLAMP,TP00351-51<EX NS23EZ>
▲ FC2	87-A90-505-080	--	FUSE CLAMP,TP00351-51<EX NS23EZ>
▲ F101	87-035-362-010		FUSE 1A/250V<EXCEPT HR,D>
▲ F101	87-035-412-010	--	FUSE T1.25A<D>
▲ F101	87-035-366-010		FUSE, 2.5A 250V<HR>
▲ PT101	86-NF2-725-010		PT,6NF-32 RDS<NS23EZ>
▲ PT101	87-NF8-607-010	--	PT,7NF-8D<D>
▲ PT101	87-NF8-608-010		PT,7NF-8EZ<G,K,NS22EZ,V>
▲ PT101	87-NF8-606-010		PT,7NF-8HR<HR>
▲ SW101	87-A90-234-010		SW,SL 1-2-2 SW2201<HR>
▲ T1	87-A60-317-010	OE	TERMINAL, 1P MSC
▲ T2	87-A60-317-010	OE	TERMINAL, 1P MSC

DECK C.B

REF. NO.	PART NO.	KANRI NO.	DESCRIPTION
CON301	86-ZM3-604-019	--	CON ASSY,3P-PB
CON351	86-ZM3-605-019	1B	CON ASSY,8P-RPB
CON502	87-099-753-019	OE	CONN,11P H 9604
SFR1	87-024-581-089	OE	SFR,3.3K DIA 6H
SOL1	82-ZM1-618-010	1B	SOL ASSY, 27
SOL2	82-ZM1-618-010	1B	SOL ASSY, 27
SW1	87-A90-248-010	OE	SW, MICRO ESE11SH2CXQ
SW2	87-A90-248-010	OE	SW, MICRO ESE11SH2CXQ
SW3	87-A90-248-010	OE	SW, MICRO ESE11SH2CXQ
SW4	87-A90-248-010	OE	SW, MICRO ESE11SH2CXQ
SW5	87-A90-248-010	OE	SW, MICRO ESE11SH2CXQ
W1	82-ZM3-601-019	OE	RBN-CORD,4P-75

NOTE:
EX = EXCEPT

TRANSISTOR ILLUSTRATION



E C B

2SC535
2SC19230
2SC3266



E C B

CSD655E
CSD1489B
CSB1058B
2SA952
C2N5551
2SC2001
2SC2002
2SA953



G S D

2SK439



E C B

2SA933S DTC144ESA
2SC1740 DTA114YSA
DTC114ES DTC143XSA
2SA1175F DTA114ES
DTA143ESA DTA144ES
DTA144WSA DTC114YS

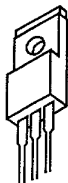

B C E

2SB1370
2SD2061



B C E

2SB1626
2SD2495



E C B

2SC3331
2SA1318



S D G

2SK2541

BLOCK DIAGRAM - 2 (MAIN / FRONT : 23EZ)

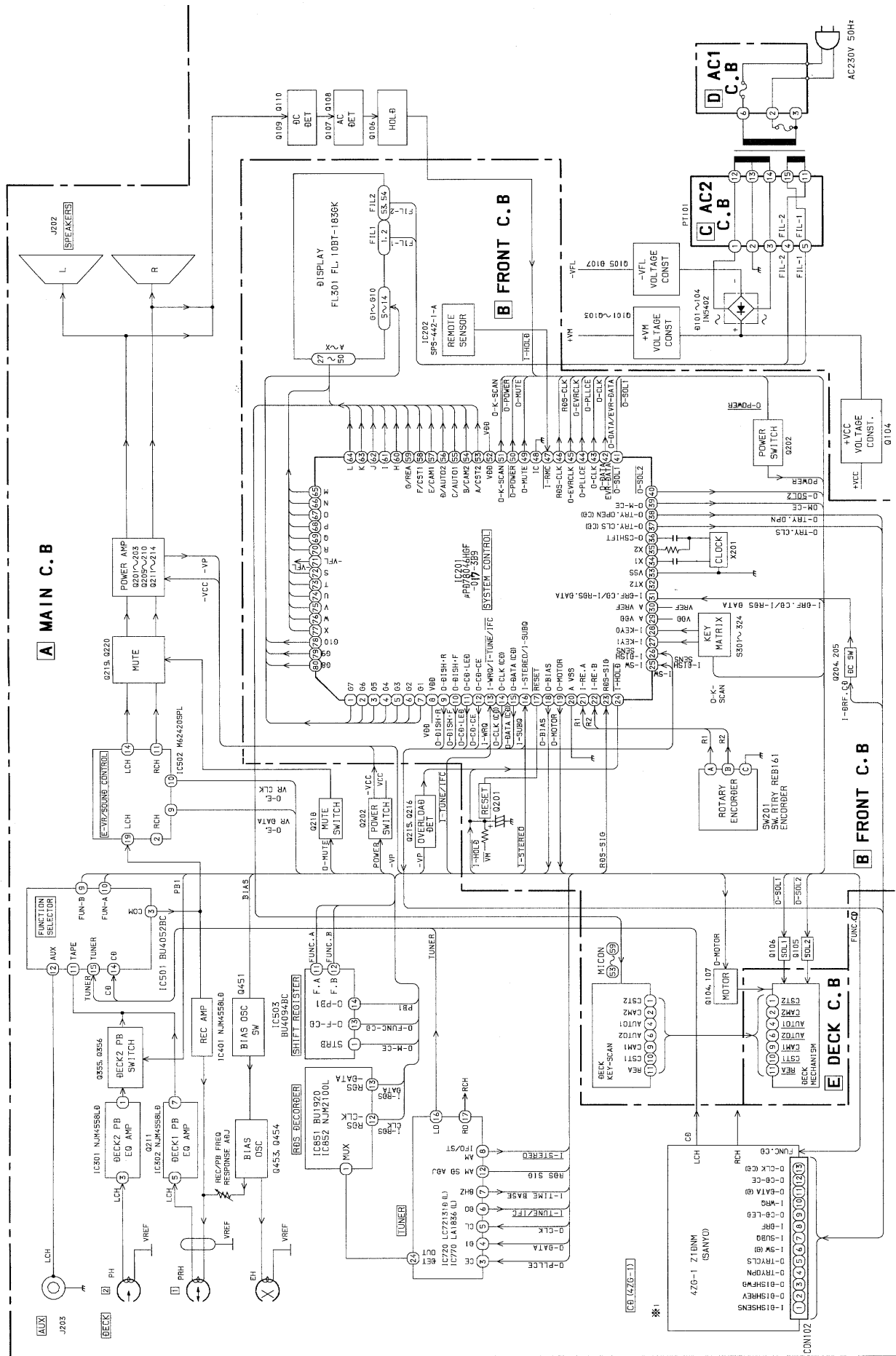

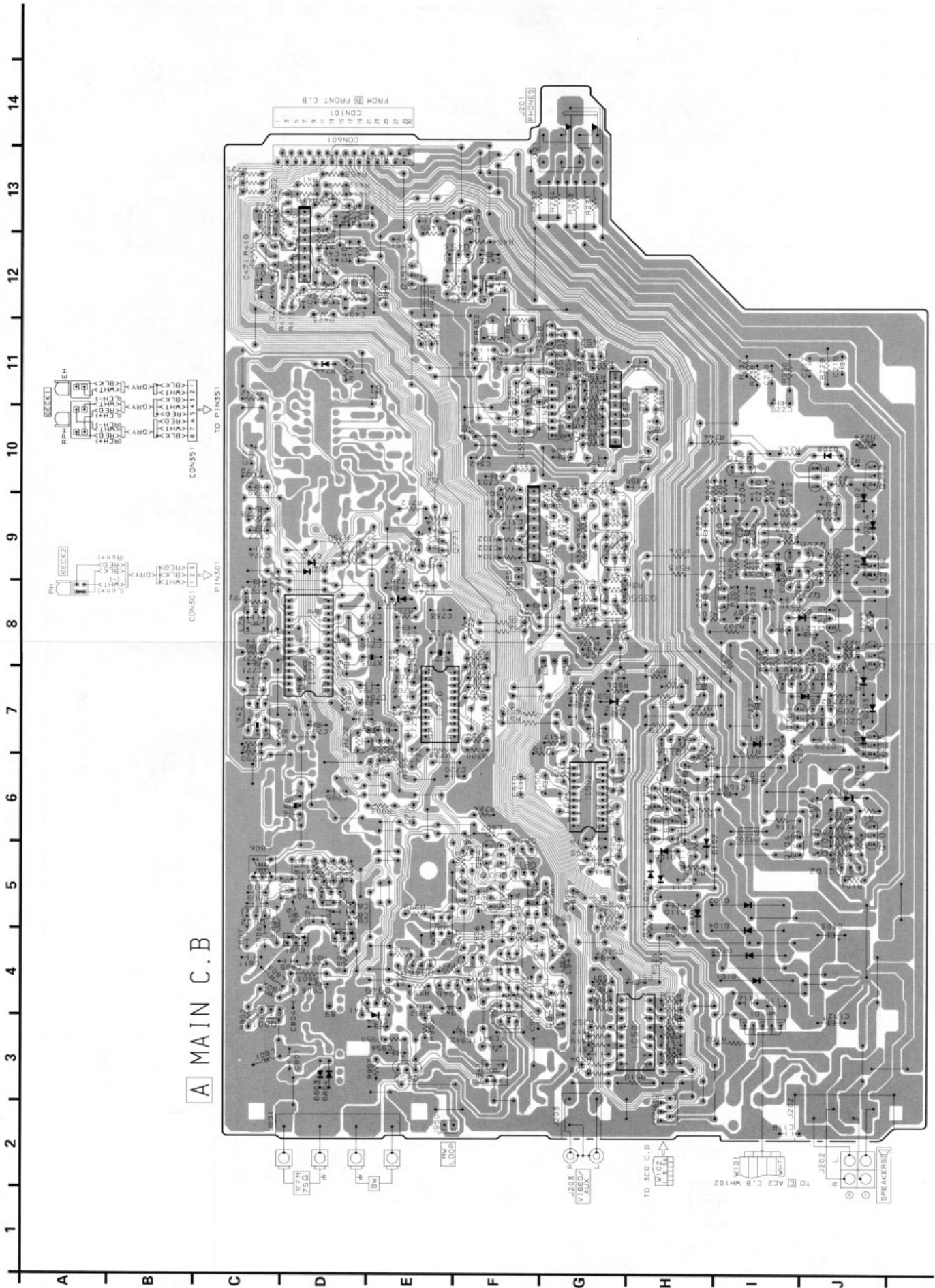

SCHEMATIC DIAGRAM - 1 (MAIN : HR)

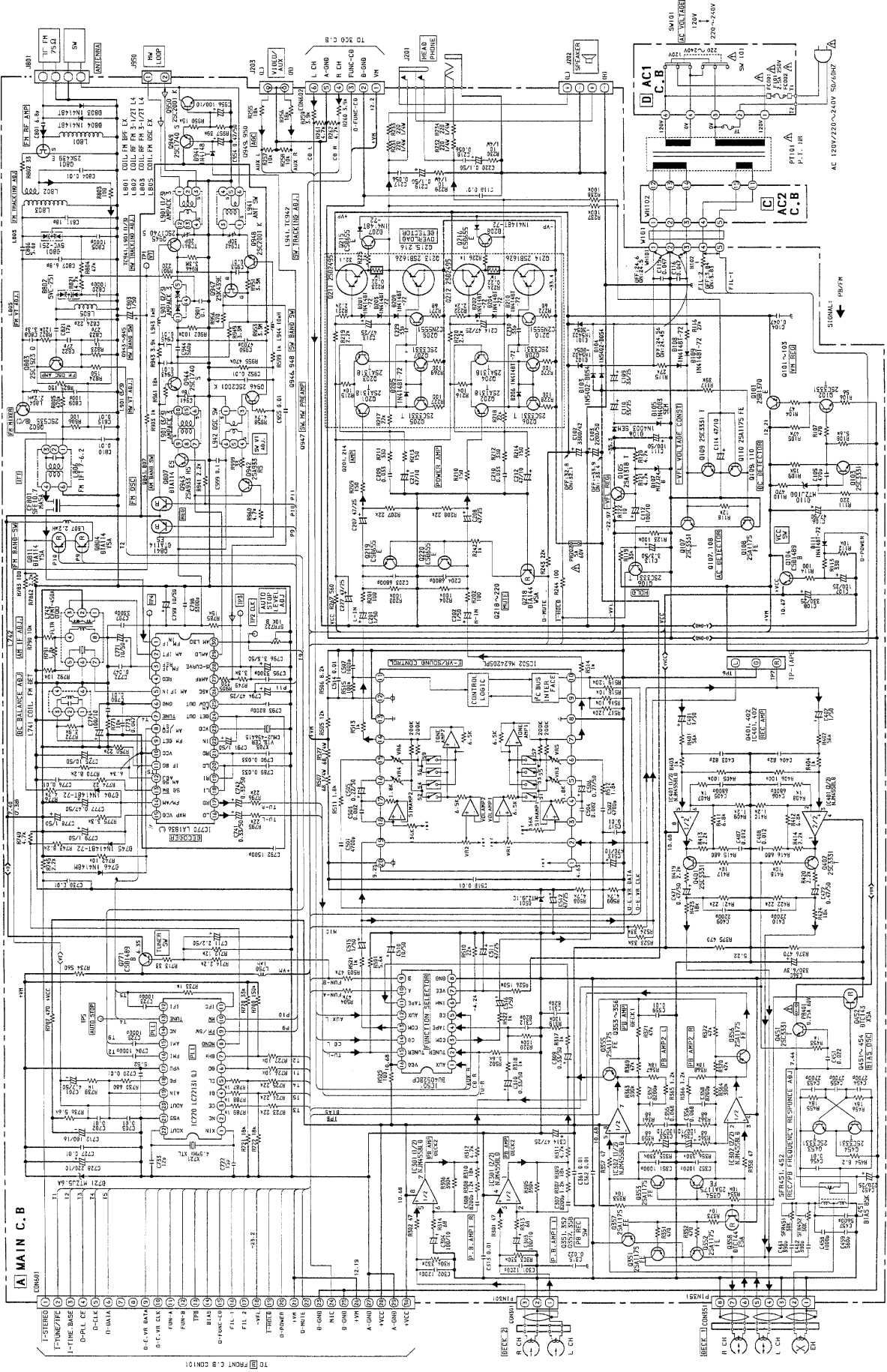

SCHEMATIC DIAGRAM - 2 (MAIN : D)

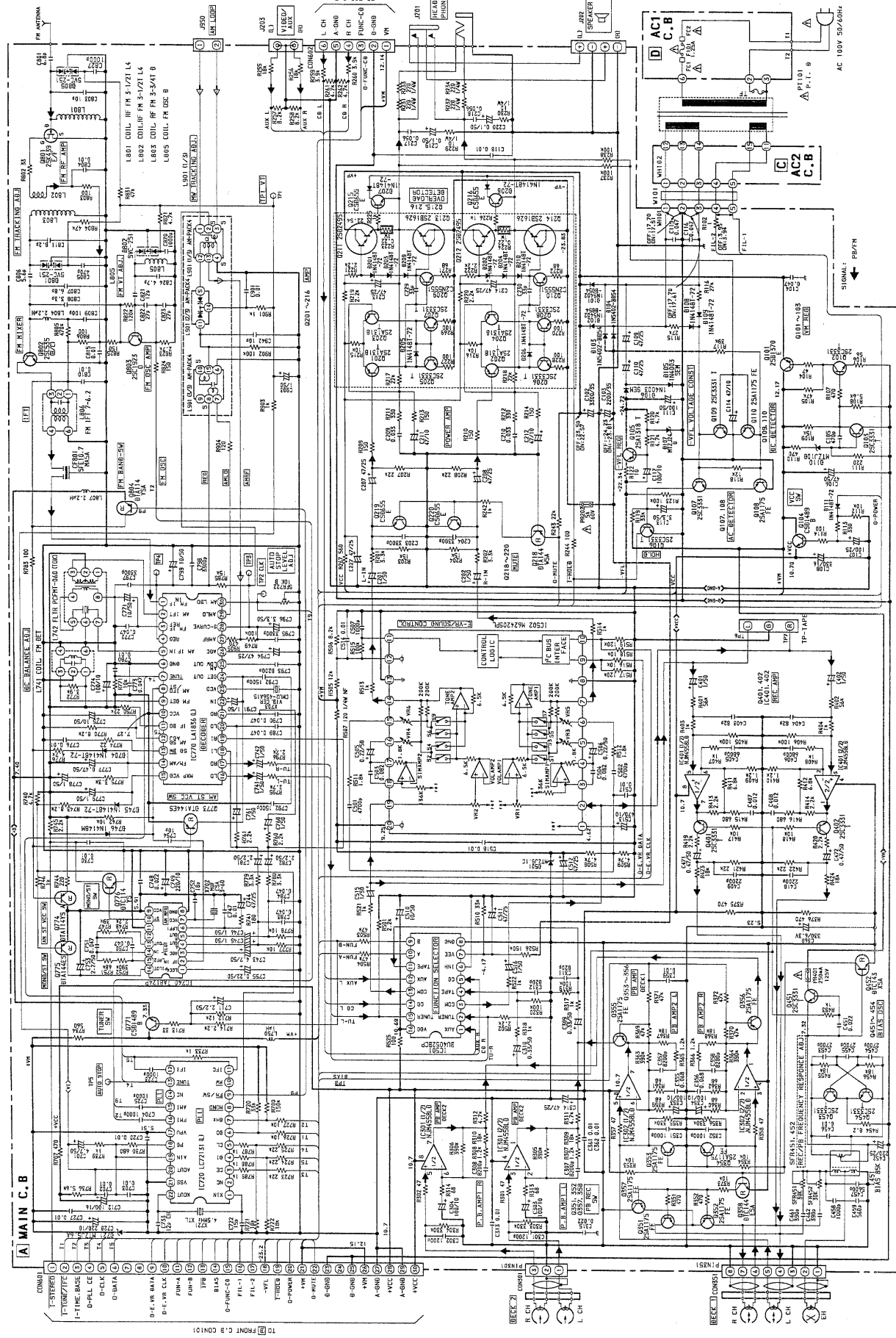

1 2 3 4 5 6 7 8 9 10 11 12 13 14

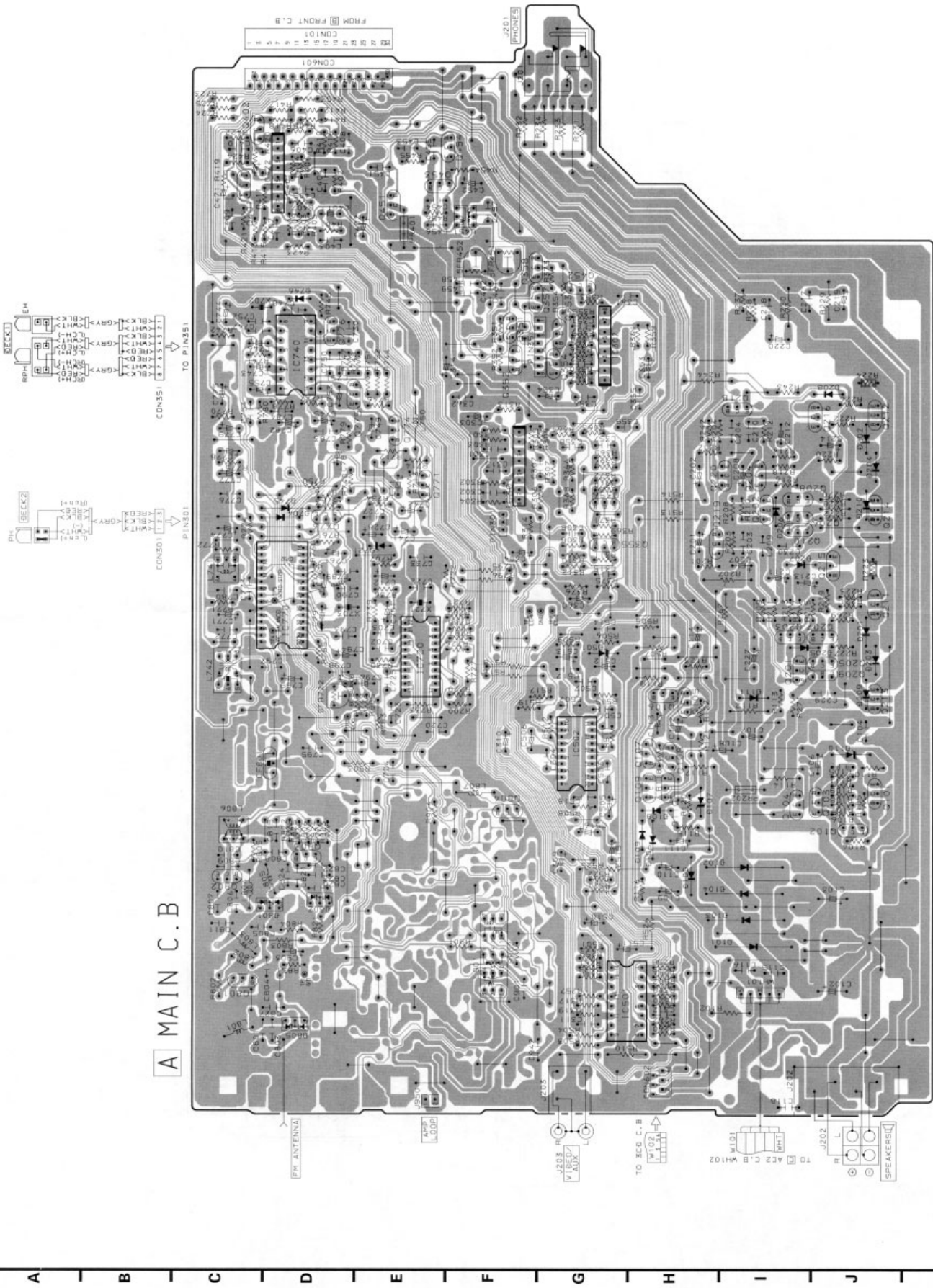

A MAIN C.B.

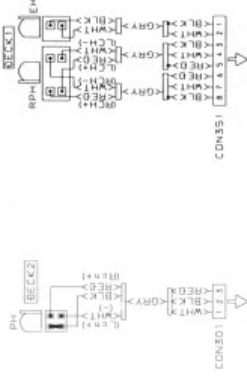

SCHEMATIC DIAGRAM - 3 (MAIN: 22EZ, K, G, V)

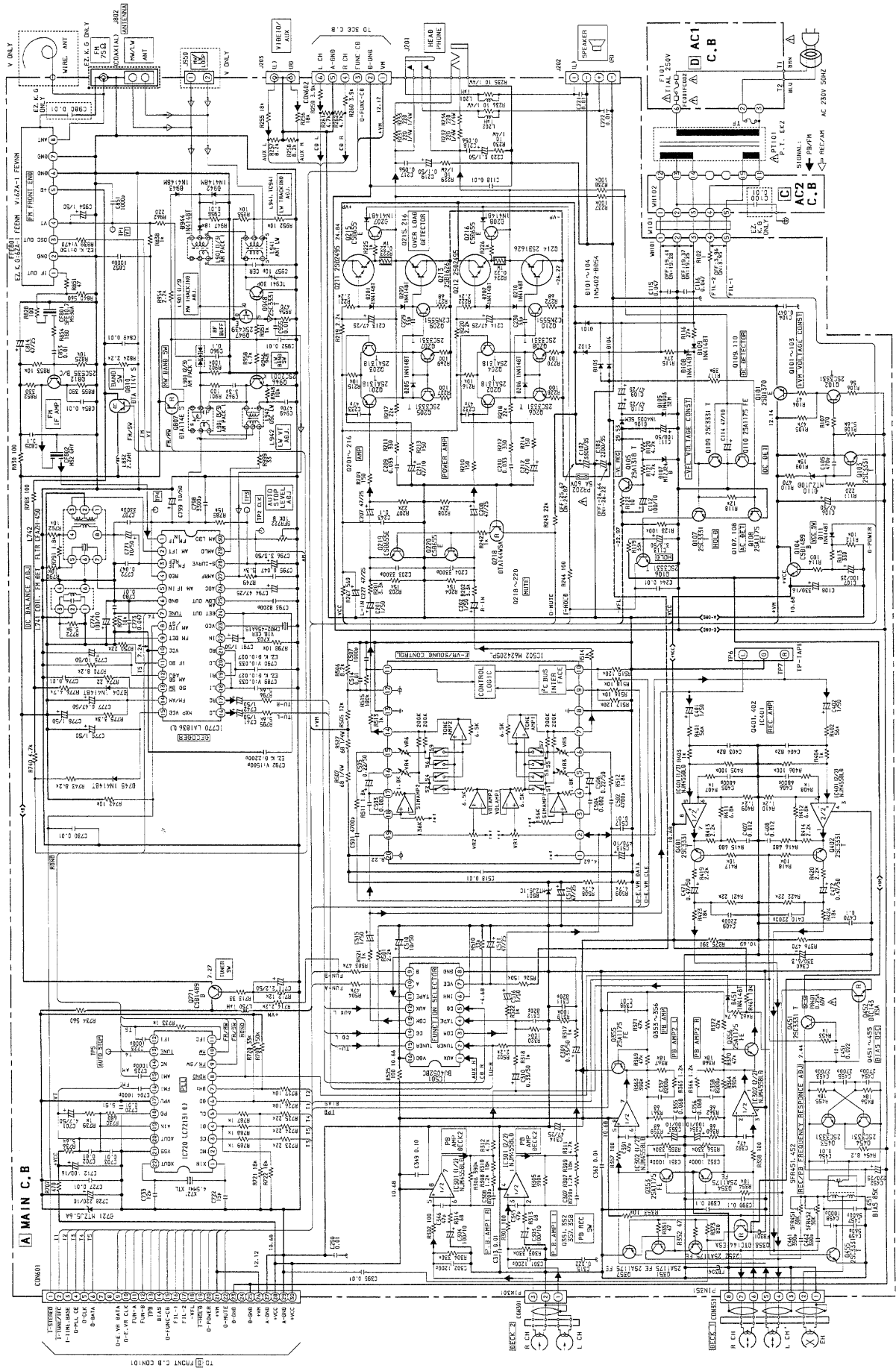

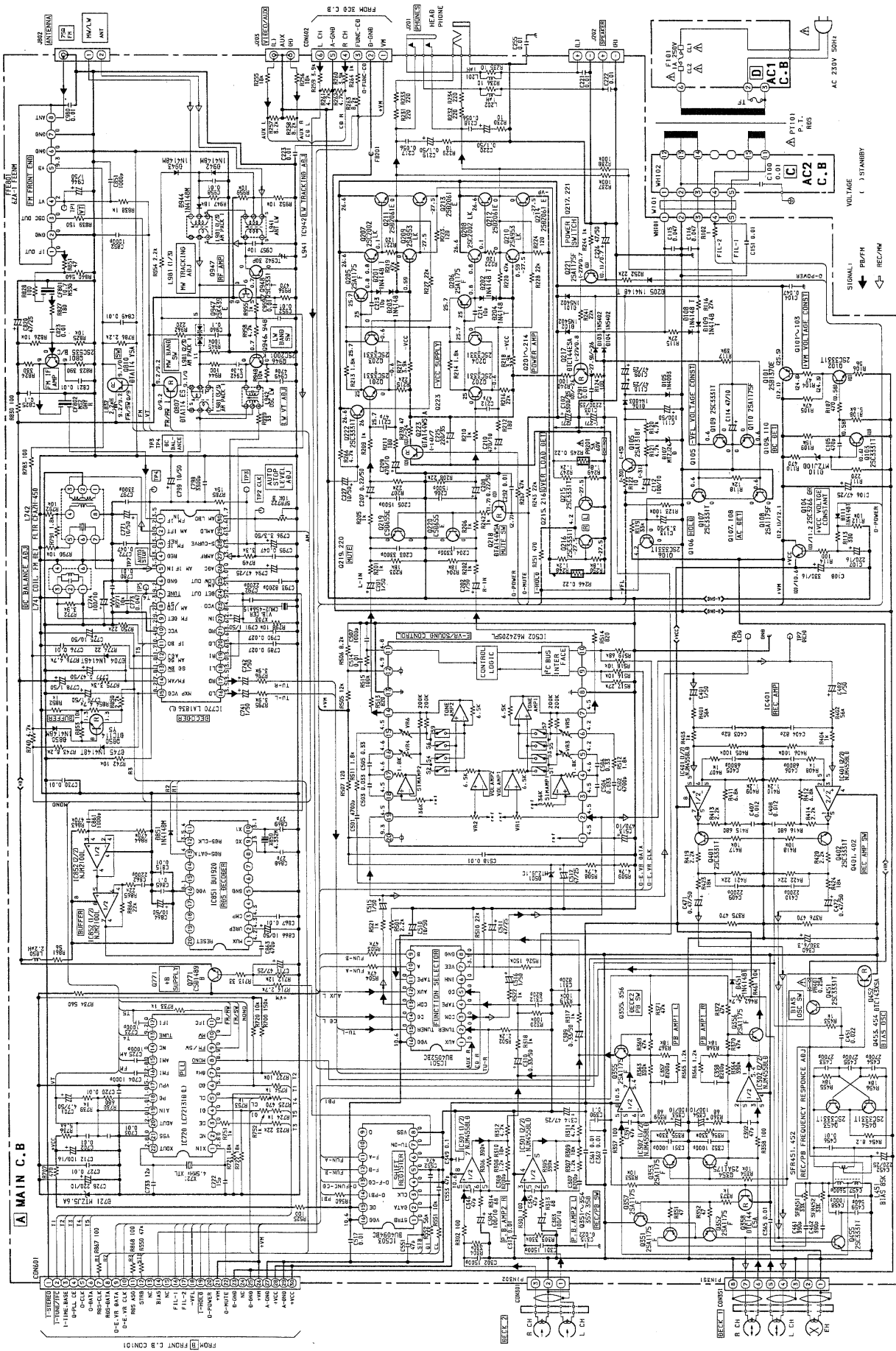

1 2 3 4 5 6 7 8 9 10 11 12 13 14

A B C D E F G H I J

A MAIN C.B.

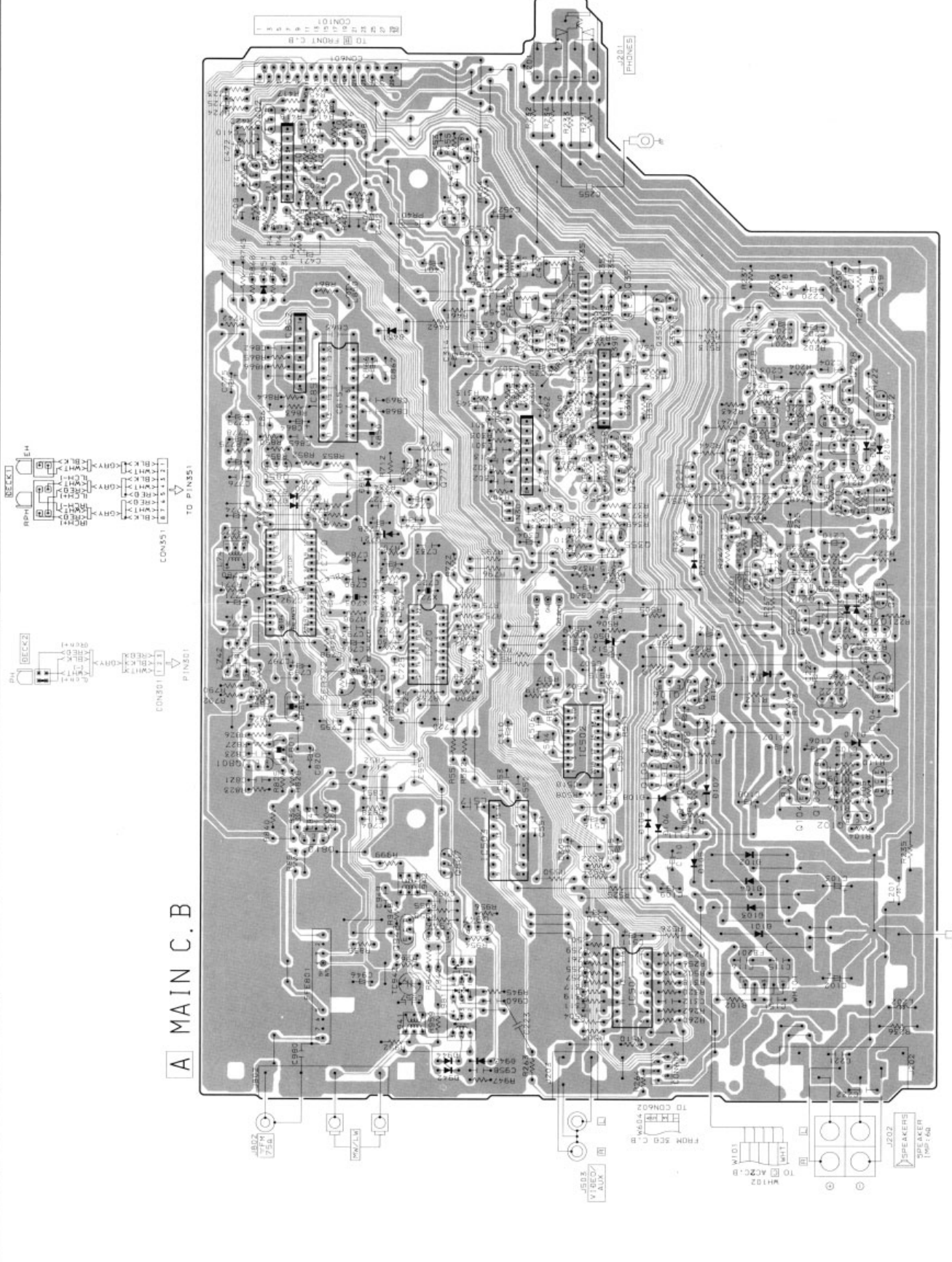

1 2 3 4 5 6 7 8 9 10 11 12 13 14

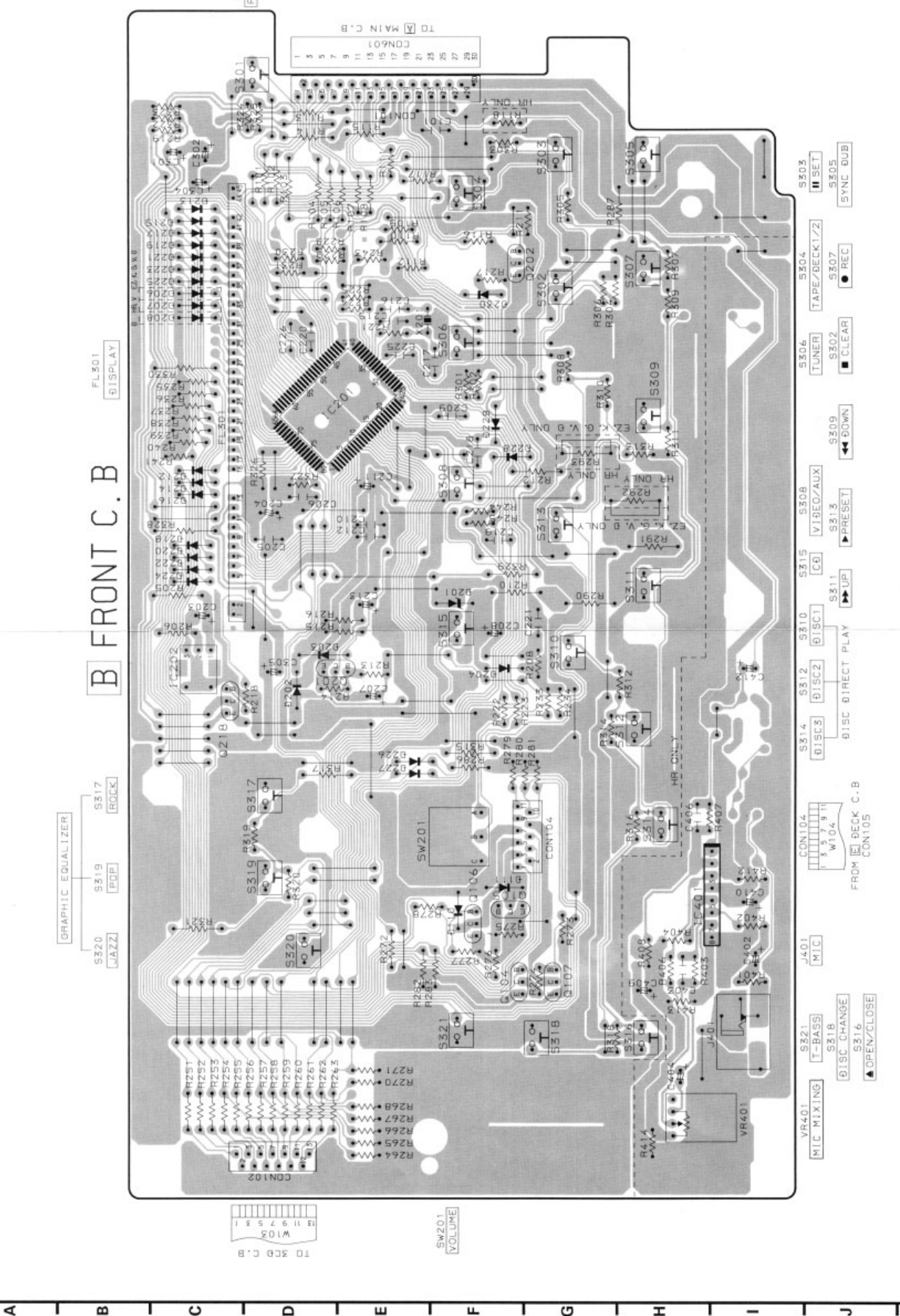

B FRONT C.B.

GRAPHIC EQUALIZER

FL301
DISPLAY

S301
POWER

TO 3CB C.B.
W103

SW201
VOLUME

VR401
MIC MIXING

S321
T-BASS

S318
BISC CHANGE

S316
OPEN/CLOSE

J401
MIC

CON104
1 2 3 4 5 6 7 8 9 10

S314
BISC3

S312
BISC2

S310
BISC1

S308
VIBED/AUX

S306
TUNER

S304
TAPE/DECK1/2

S303
SET

S305
SYNC DUB

S319
JAZZ

S317
POP

S315
ROCK

S313
PRESET

S311
UP

S309
DOWN

S307
CLEAR

S305
REC

S303
SET

S301
POWER

S300
MAIN C.B.

SCHEMATIC DIAGRAM - 6 (FRONT : 23EZ)

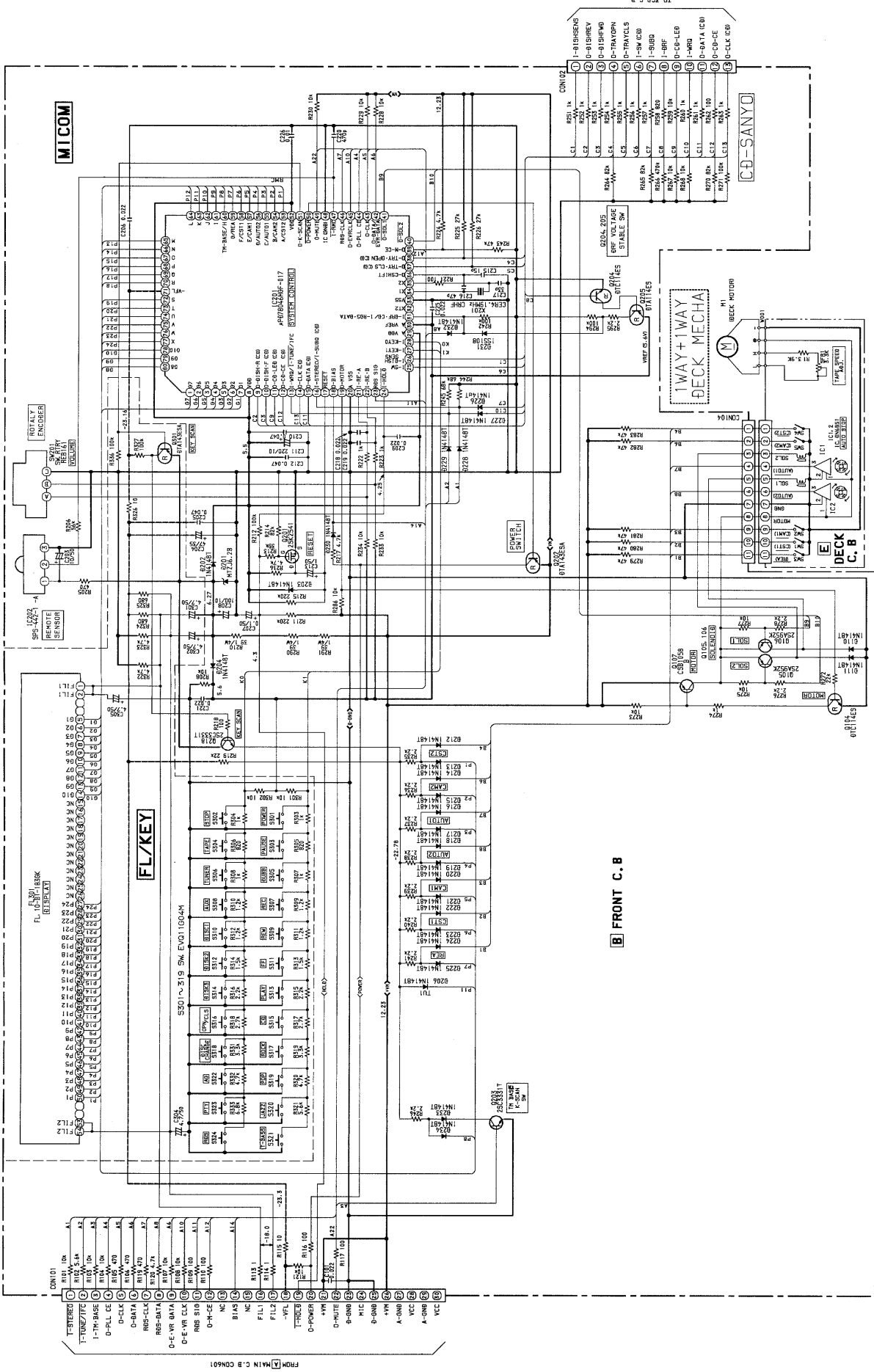

FRONT MAIN C.B. C09601

WIRING - 7 (AC1 / AC2 : HR,D)

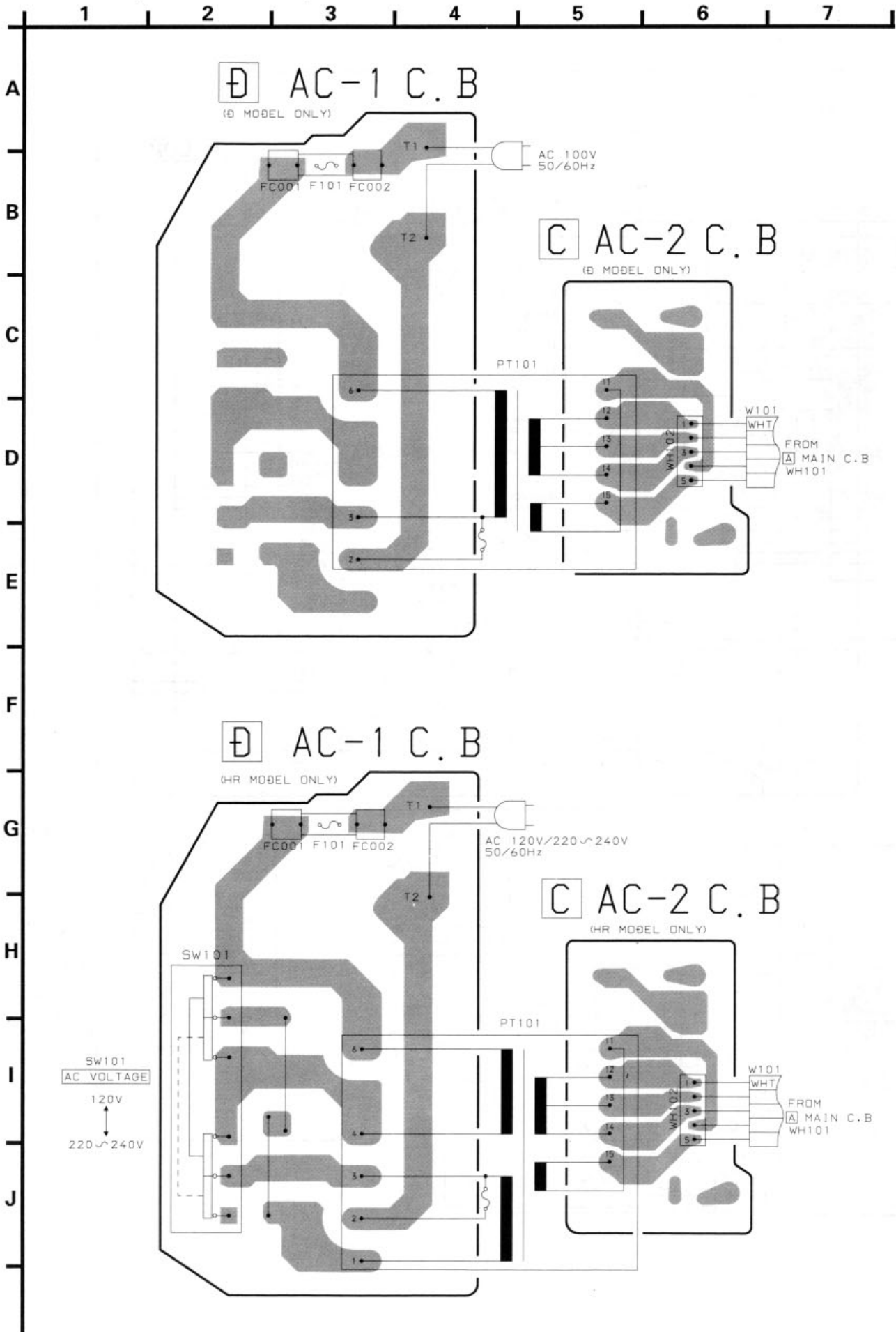

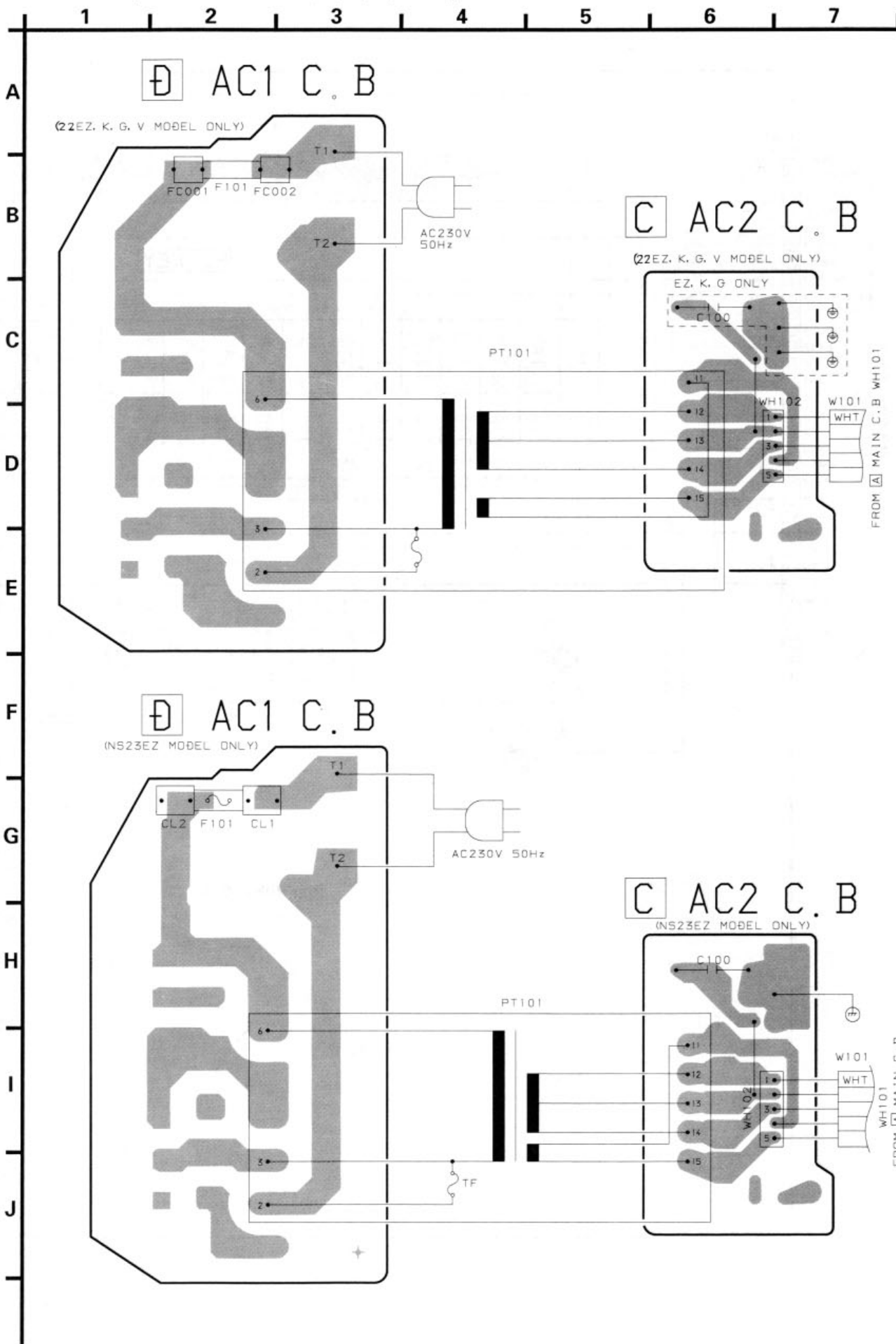

WIRING - 9 (DECK)

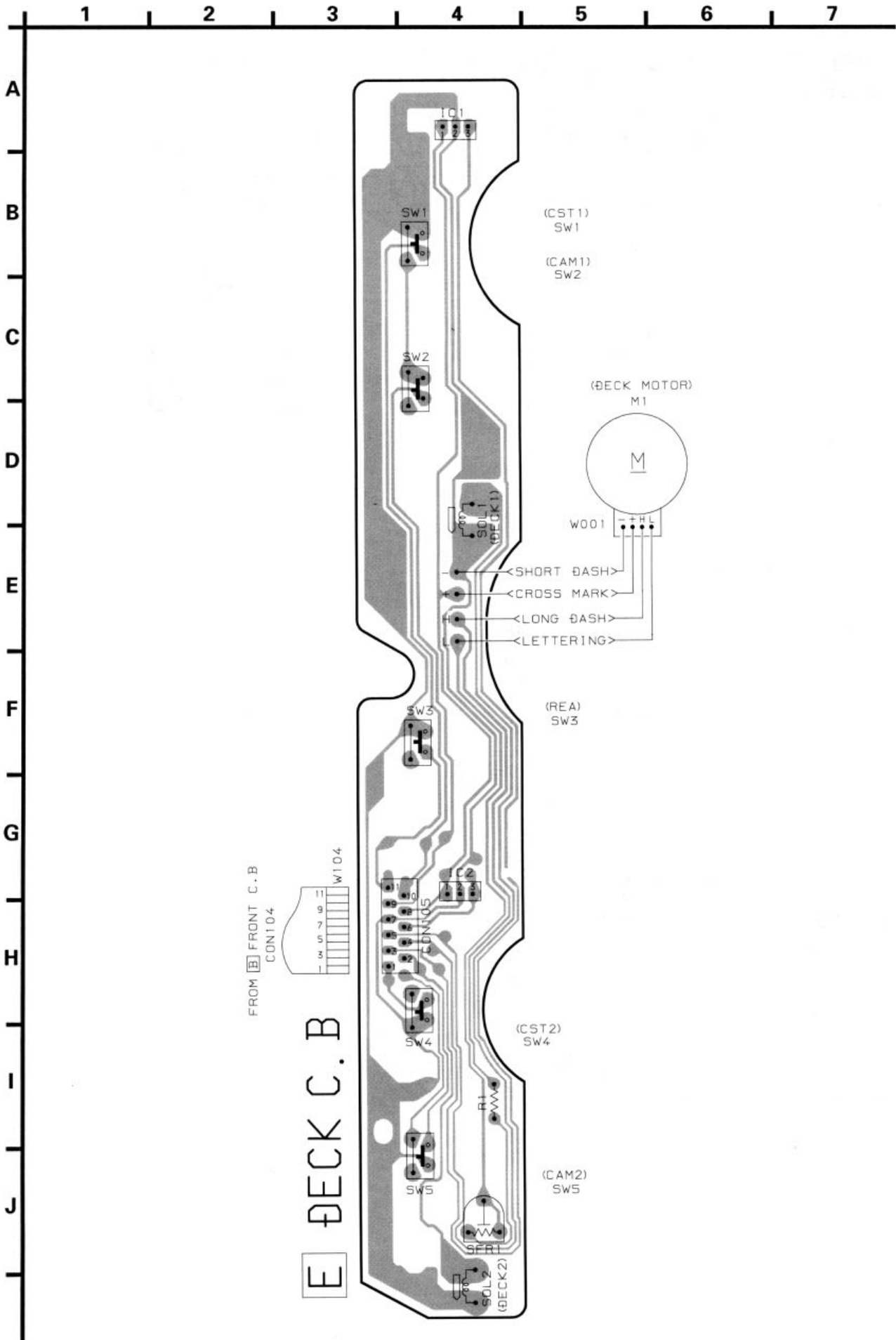

FL (7BT-185GK) GRID ASSIGNMENT AND ANODE CONNECTION

GRID ASSIGNMENT

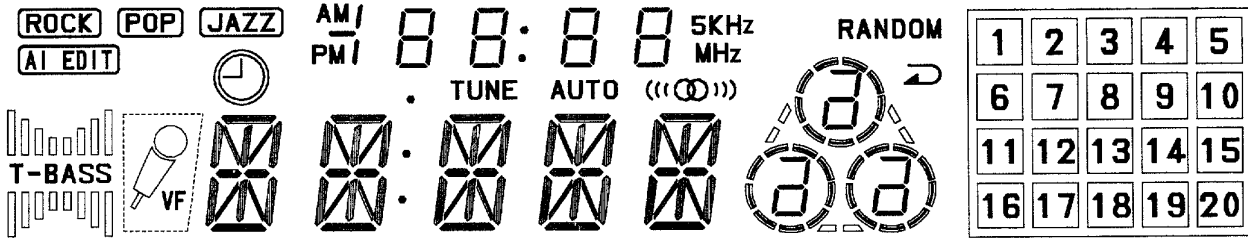

SEGMENT DESIGNATION

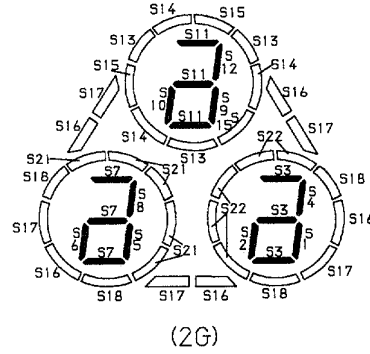
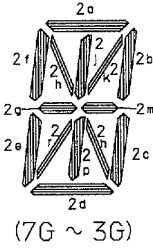
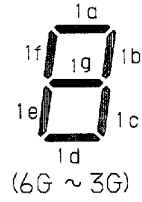

ANODE CONNECTION

	7G	6G	5G	4G	3G	2G	1G
P1	2d	2e	2d	2e	2d	S1	20
P2	2j, 2p	2i, 2p	2j, 2p	2i, 2p	2j, 2p	S2	19
P3	2n	2n	2n	2n	2n	S3	18
P4	2r	2r	2r	2r	2r	S4	17
P5	2c	2c	2c	2c	2c	S5	16
P6	2e	2e	2e	2e	2e	S6	15
P7	2m	2m	2m	2m	2m	S7	14
P8	2q	2q	2q	2q	2q	S8	13
P9	2f	2f	2f	2f	2f	S9	12
P10	2b	2b	2b	2b	2b	S10	11
P11	2k	2k	2k	2k	2k	S11	10
P12	2h	2h	2h	2h	2h	S12	9
P13	2a	2a	2a	2a	2a	S13	8
P14	VF	.	TUNE	AUTO	((()))	S14	7
P15	T-BASS	o	o (F)	—	MHz	S15	6
P16	AI EDIT	—	o (L)	—	KHz	S16	5
P17	PM	—	—	—	5	S17	4
P18	PM	1e	1d	1e	1d	S18	3
P19	—	1e	1e	1e	1e	—	2
P20	/	1c	1c	1c	1c	—	1
P21	AM	1q	1q	1q	1q	S21	—
P22	(JAZZ)	1f	1f	1f	1f	S22	—
P23	(POP)	1b	1b	1b	1b	↶	—
P24	(ROCK)	1a	1a	1a	1a	RANDOM	—
P25	—	—	—	—	—	—	⏏

FL (10BT-183GK) GRID ASSIGNMENT AND ANODE CONNECTION

GRID ASSIGNMENT

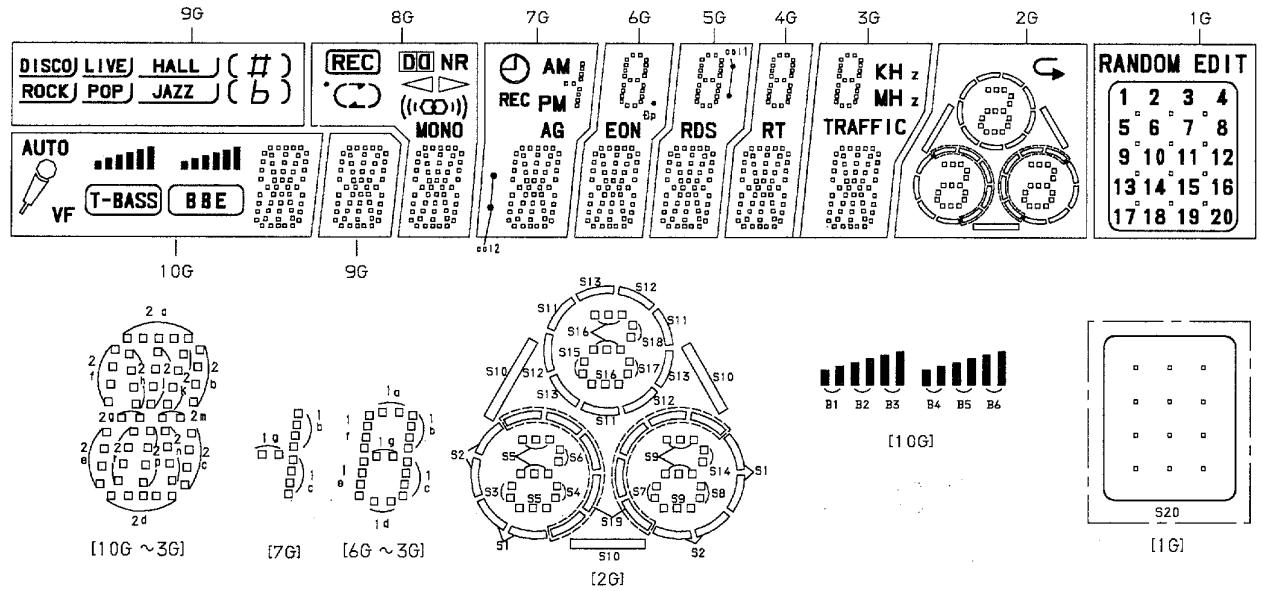

ANODE CONNECTION

	10G	9G	8G	7G	6G	5G	4G	3G	2G	1G
P1	2d	2d	2d	2d	2d	2d	2d	2d	S1	20
P2	2n	2n	2n	2n	2n	2n	2n	2n	S2	19
P3	2p	2p	2p	2p	2p	2p	2p	2p	S3	18
P4	2r	2r	2r	2r	2r	2r	2r	2r	S4	17
P5	2e	2e	2e	2e	2e	2e	2e	2e	S5	16
P6	2c	2c	2c	2c	2c	2c	2c	2c	S6	15
P7	2g	2g	2g	2g	2g	2g	2g	2g	S7	14
P8	2m	2m	2m	2m	2m	2m	2m	2m	S8	13
P9	2f	2f	2f	2f	2f	2f	2f	2f	S9	12
P10	2b	2b	2b	2b	2b	2b	2b	2b	S10	11
P11	2k	2k	2k	2k	2k	2k	2k	2k	S11	10
P12	2j	2j	2j	2j	2j	2j	2j	2j	S12	9
P13	2h	2h	2h	2h	2h	2h	2h	2h	S13	8
P14	2a	2a	2a	2a	2a	2a	2a	2a	S14	7
P15	BBE	(DISCO)	MONO	AG	EON	RDS	RT	TRAFFIC	S15	6
P16	T-BASS	(LIVE)	(MONO)	c o l	—	c o (LOWER)	—	MHz	S16	5
P17	ϕ_{VF}	(HALL)	\triangleleft	REC	δp	c o (UPPER)	—	KHz	S17	4
P18	AUTO	(ROCK)	\triangleright	\odot	1d	1d	1d	1d	S18	3
P19	B1	(POP)	\circ	PM	1e	1e	1e	1e	S19	2
P20	B2	(JAZZ)	\subset	AM	1c	1c	1c	1c	\curvearrowright	1
P21	B3	([#])	Σ	1g	1g	1g	1g	1g	—	RANDOM
P22	B4	([b])	\cup	1b, 1c	1f	1f	1f	1f	—	EDIT
P23	B5	DISCO LIVE HALL	REC	—	1b	1b	1b	1b	—	S20
P24	B6	ROCK POP JAZZ	DO NR	—	1a	1a	1a	1a	—	—
P25	—	# b	—	—	—	—	—	—	—	—

IC DESCRIPTION <22EZ, K, G, V, HR, 23EZ>

IC, μ PD78044HGF-026-3B9 (EXCEPT NS23EZ)

Pin No.	Pin Name	I/O	Description															
1~7	G7~G1	O	FL grid output.															
8	VDD	-	Power supply input.															
9	O-DISH-R	O	CD turntable reverse rotation output.															
10	O-DISH-F	O	CD turntable forward rotation output.															
11	O-CD-LED	O	CD flash window LED ON/OFF output.															
12	O-CDCE(CD)	O	CDCE output.															
13	I-DRF	I	DRF input.															
14	O-CLK(CD)	O	CLK output.															
15	O-DATA(CD)	O	DATA output.															
16	I-SUBQ(CD) / I-STEREO	I	SUB-Q input / Tuner stereo input.															
17	RESET	-	Reset input.															
18	O-BIAS	O	DECK bias control ON/OFF output.															
19	O-MOTOR	O	DECK motor ON/OFF output.															
20	A VSS	-	GND.															
21	I-WRQ (CD) / I-TUNE / IFC	I	CD-WRQ input / Tuner.SD input / IF data input.															
22	I-RE.A	I	Rotary-encoder A input.															
23	I-RE.B	I	Rotary-encoder B input.															
24	I-HOLD	I	Hold AD input.															
25	I-CDSW (AD)	I	CD mecha SW AD input.															
26	I-DISH SENS (AD)	I	CD turntable photo sensor A/D converter input.															
27,28	I-KEY0,1(AD)	I	Key0, 1 input. (A/D)															
29	A VDD	-	Power supply input.															
30	A VREF	-	Reference voltage. (+5V)															
31	I-TMBASE	I	Reference clock input for timer watch.															
32	XT2	-	Not used.															
33	VSS	-	GND.															
34,35	X1,X2	I/O	511.47Hz oscillator circuit.															
36	O-CSHIFT	O	Micon clock shift output. (active high)															
37	O-FUNC-CD	O	Power supply for CD. Output ON/OFF.															
38	O-FUNC-B	O	Function switch output.															
39	O-FUNC-A		<table border="1"> <thead> <tr> <th></th> <th>AUX</th> <th>TUNER</th> <th>CD</th> <th>TAPE</th> </tr> </thead> <tbody> <tr> <td>O-FUNCA</td> <td>0</td> <td>0</td> <td>1</td> <td>1</td> </tr> <tr> <td>O-FUNCB</td> <td>0</td> <td>1</td> <td>0</td> <td>1</td> </tr> </tbody> </table>		AUX	TUNER	CD	TAPE	O-FUNCA	0	0	1	1	O-FUNCB	0	1	0	1
	AUX		TUNER	CD	TAPE													
O-FUNCA	0	0	1	1														
O-FUNCB	0	1	0	1														
40	O-SOL2	O	DECK SOL2 ON/OFF output.															
41	O-SOL1	O	DECK SOL1 ON/OFF output.															
42	O-DATA	O	PLL IC data output.															
43	O-CLK	O	PLL IC clock output.															
44	O-PLLCE	O	PLL IC chip enable.															
45	O-EVRCLK	O	Electrical volume clock output.															

Pin No.	Pin Name	I/O	Description
46	O-EVRDATA	O	Electrical volume data output.
47	I-RMC	I	System remote control signal input.
48	IC	-	Connected to GND.
49	O-MUTE	O	System mute output.
50	O-POWER	O	System power supply ON/OFF output.
51	O-PBT	O	Playback Deck 1 and 2 switch output. "L" = Deck 1.
52	VDD	-	Power supply input.
53	A/CST2	O	FL segment output P24/DECK (CST2) sw input.
54	B/CAM2	O	FL segment output P23/DECK (CAM2) sw input.
55	C/AUTO1	O	FL segment output P22/DECK (AUTO1) sw input.
56	D/AUTO2	O	FL segment output P21/DECK (AUTO2) sw input.
57	E/CAM1	O	FL segment output P20/DECK (CAM1) sw input.
58	F/CST1	O	FL segment output P19/DECK (CST1) sw input.
59	G/REA	O	FL segment output P18/DECK (REA) sw input.
60~70	H-R	O	FL segment output P17~P7
71	-VFL	-	Power for FL display.
72~77	S-X	O	FL segment output P6~P1.
78	O-K-SCAN	O	Key scan output .
79	O-TRYCLS (CD)	O	CD tray close data output.
80	O-TRYOPN (CD)	O	CD tray open data output.

Pin No.	Pin Name	I/O	Description																								
1	XIN	I/O	A crystal oscillator (7.2MHz) is connected between these pins.																								
22	XOUT																										
2	NC	-	Not used.																								
3	CE	I	To enable the IC. Active "H".																								
4	DI	I	Digital data input from CPU when relevant key is operated. Active "H".																								
5	CLK	I	To clock in the data DI.																								
6	DO	O	Digital data output to CPU.																								
7	TM-BASE	O	Outputs a reference clock signal (8Hz) for the clock.																								
8	MONO / BEAT	O	Outputs "H" when MONO / BEAT is switched.																								
9	$\overline{\text{FM}} / \text{AM}$	O	Output "L" or "H" as follows: <table border="1" style="margin-left: 20px;"> <thead> <tr> <th colspan="2">2 BAND</th> <th colspan="3">3 BAND</th> <th colspan="3">3 BAND</th> </tr> <tr> <th>AM</th> <th>FM</th> <th>LW</th> <th>MW</th> <th>FM</th> <th>MW</th> <th>SW</th> <th>FM</th> </tr> </thead> <tbody> <tr> <td>H</td> <td>L</td> <td>H</td> <td>H</td> <td>L</td> <td>H</td> <td>L</td> <td>L</td> </tr> </tbody> </table>	2 BAND		3 BAND			3 BAND			AM	FM	LW	MW	FM	MW	SW	FM	H	L	H	H	L	H	L	L
2 BAND		3 BAND			3 BAND																						
AM	FM	LW	MW	FM	MW	SW	FM																				
H	L	H	H	L	H	L	L																				
10	$\overline{\text{MW}}$	O	Outputs "L" or "H" as follows: <table border="1" style="margin-left: 20px;"> <thead> <tr> <th colspan="2">2 BAND</th> <th colspan="3">3 BAND</th> <th colspan="3">3 BAND</th> </tr> <tr> <th>AM</th> <th>FM</th> <th>LW</th> <th>MW</th> <th>FM</th> <th>MW</th> <th>SW</th> <th>FM</th> </tr> </thead> <tbody> <tr> <td>L</td> <td>L</td> <td>H</td> <td>L</td> <td>L</td> <td>L</td> <td>H</td> <td>L</td> </tr> </tbody> </table>	2 BAND		3 BAND			3 BAND			AM	FM	LW	MW	FM	MW	SW	FM	L	L	H	L	L	L	H	L
2 BAND		3 BAND			3 BAND																						
AM	FM	LW	MW	FM	MW	SW	FM																				
L	L	H	L	L	L	H	L																				
11	IF-MUTE	O	To control internal counter.																								
12	IFIN	I	General purpose counter input.																								
13	$\overline{\text{TUNE}}$	I	Receives "L" when station is tuned.																								
14	NC	-	Not used.																								
15	A MIN	I	Receives the AM local oscillator frequency signal.																								
16	F MIN	I	Receives the FM local oscillator frequency signal.																								
17	VDD	-	Supply power to IC (+5V).																								
18	PD	O	PLL charge pump output.																								
19	AIN	I	The MOS transistor for PLL active low pass filter.																								
20	AOUT	O																									
21	VSS	-	Ground.																								

IC, μ PD78046HGF-017-3B9 (NS23EZ)

Pin No.	Pin Name	I/O	Description
1~7	G7~G1	O	FL grid output.
8	VDD	-	Power supply input.
9	O-DISH-R(CD)	O	CD turntable reverse rotation output.
10	O-DISH-F(CD)	O	CD turntable forward rotation output.
11	O-CD-LED(CD)	O	CD flash window LED ON/ $\overline{\text{OFF}}$ output.
12	O-CDCE(CD)	O	CDCE output.
13	I-WRQ/I-TUNE/IFC	I	CD-WRQ input / Tuner SD input / IF data input.
14	O-CLK(CD)	O	CLK output.
15	O-DATA(CD)	O	DATA output.
16	I-STEREO / I-SUBQ(CD)	I	Tuner stereo input / SUB-Q input .
17	$\overline{\text{RESET}}$	-	Reset input.
18	O-BIAS	O	DECK bias control ON/ $\overline{\text{OFF}}$ output.
19	O-MOTOR	O	DECK motor ON/ $\overline{\text{OFF}}$ output.
20	A VSS	-	GND.
21	I-RE.A	I	Rotary-encoder A input.
22	I-RE.B	I	Rotary-encoder B input.
23	RDS-SIG	I	RDS signal input.
24	$\overline{\text{I-HOLD}}$	I	Hold AD input.
25	I-SW	I	CD mecha SW AD input.
26	I-DISH SENS	I	CD turntable photo sensor A/D converter input.
27,28	I-KEY0,1	I	Key0, 1 input. (A/D)
29	A VDD	-	Power supply input.
30	A VREF	-	Reference voltage. (+5V)
31	I-DRF.CD / I-RDS-DATA	I	CD DRF input / Tuner RDS data input.
32	XT2	-	Not used.
33	VSS	-	GND.
34,35	X1,X2	I/O	511.47Hz oscillator circuit.
36	O-CSHIFT	O	Micon clock shift output. (active high)
37	O-TRY.CLS (CD)	O	CD tray close data output.
38	O-TRY.OPEN (CD)	O	CD tray open data output.
39	O-M-CE	O	Main shift register chip enable.
40	O-SOL $\overline{2}$	O	DECK SOL2 $\overline{\text{ON}}$ / $\overline{\text{OFF}}$ output.
41	O-SOL $\overline{1}$	O	DECK SOL1 $\overline{\text{ON}}$ / $\overline{\text{OFF}}$ output.
42	O-DATA/EVR-DATA	O	PLL IC data output / Electrical volume data output.
43	O-CLK	O	PLL IC clock output.
44	O-PLLCE	O	PLL IC chip enable.
45	O-EVRCLK	O	Electrical volume clock output.

Pin No.	Pin Name	I/O	Description
46	RDS-CLK	I	RDS clock input.
47	I- \overline{RMC}	I	System remote control signal input.
48	IC (GND)	-	Connected to GND.
49	O-MUTE	O	System mute output.
50	O-POWER	O	System power supply $\overline{ON/OFF}$ output.
51	O-K-SCAN	O	Key scan output.
52	VDD	-	Power supply input.
53	A/CST2	O	FL segment output P24/DECK ($\overline{CST2}$) sw input.
54	B/CAM2	O	FL segment output P23/DECK ($\overline{CAM2}$) sw input.
55	C/AUTO1	O	FL segment output P22/DECK ($\overline{AUTO1}$) sw input.
56	D/AUTO2	O	FL segment output P21/DECK ($\overline{AUTO2}$) sw input.
57	E/CAM1	O	FL segment output P20/DECK ($\overline{CAM1}$) sw input.
58	F/CST1	O	FL segment output P19/DECK ($\overline{CST1}$) sw input.
59	G/REA	O	FL segment output P18/DECK (\overline{REA}) sw input.
60~70	H~R	O	FL segment output P17~P7
71	-VFL	-	Power for FL display.
72~77	S~X	O	FL segment output P6~P1.
78~80	G10 ~ G8	O	FL grid output .

IC DESCRIPTION (D)

IC, μ PD78044HGF-026-3B9

Pin No.	Pin Name	I/O	Description(説明)															
1~7	G7~G1	O	FLグリッド出力															
8	VDD	-	電源入力															
9	O-DISH.R	O	CD ターンテーブル逆回転出力															
10	O-DISH.F	O	CD ターンテーブル正回転出力															
11	O-CD.LED	O	CDフラッシュウインドウ LED ON/OFF 出力															
12	O-CDCE (CD)	O	CDCE 出力															
13	I-DRF	I	DRF 出力															
14	O-CLK (CD)	O	クロック(CLK)出力															
15	O-DATA (CD)	O	データ(DATA)出力															
16	I-SUBQ (CD) / I-STEREO	I	SUB-Q 入力 / チューナーステレオ入力															
17	$\overline{\text{RESET}}$	-	リセット入力															
18	$\overline{\text{O-BIAS}}$	O	DECK バイアス制御 ON/OFF 出力															
19	O-MOTOR	O	DECK モーター ON/OFF 出力															
20	A VSS	-	GND															
21	I-WRQ (CD) / $\overline{\text{I-TUNE}}$ / IFC	I	CD-WRQ 入力 / チューナー SD 入力 / IF データ入力															
22	I-RE.A	I	回転エンコーダー A 入力															
23	I-RE.B	I	回転エンコーダー B 入力															
24	$\overline{\text{I-HOLD}}$	I	AD 入力を制止															
25	I-CDSW (AD)	I	CD メカ SW AD 入力															
26	I-DISH SENS (AD)	I	CD ターンテーブルフォトセンサー A/D 変換入力															
27, 28	I-KEY0, 1 (AD)	I	KEY0,1 入力(A/D)															
29	A VDD	-	電源入力															
30	A VREF	-	リファレンス電圧(+5V)															
31	I-TMBASE	I	タイマー用参考クロック入力															
32	XT2	-	未使用															
33	VSS	-	GND															
34, 35	X1, X2	I/O	511.47Hz 発振子回路															
36	O-CSHIFT	O	マイコンクロックシフト出力 (“H” アクティブ)															
37	$\overline{\text{O-FUNC-CD}}$	O	CD 用電源。ON/OFF を出力															
38	O-FUNC-B	O	ファンクションスイッチ出力 <table border="1" style="margin-left: 20px;"> <thead> <tr> <th></th> <th>AUX</th> <th>TUNER</th> <th>CD</th> <th>TAPE</th> </tr> </thead> <tbody> <tr> <td>O-FUNCA</td> <td>0</td> <td>0</td> <td>1</td> <td>1</td> </tr> <tr> <td>O-FUNCB</td> <td>0</td> <td>1</td> <td>0</td> <td>1</td> </tr> </tbody> </table>		AUX	TUNER	CD	TAPE	O-FUNCA	0	0	1	1	O-FUNCB	0	1	0	1
	AUX			TUNER	CD	TAPE												
O-FUNCA	0	0	1	1														
O-FUNCB	0	1	0	1														
39	O-FUNC-A																	
40	$\overline{\text{O-SOL2}}$	O	DECK SOL2 ON/OFF 出力															
41	$\overline{\text{O-SOL1}}$	O	DECK SOL1 ON/OFF 出力															
42	O-DATA	O	PLL IC データ出力															
43	O-CLK	O	PLL IC クロック出力															
44	O-PLLCE	O	PLL IC チップ作動可能															
45	O-EVRCLK	O	音量クロック出力															

Pin No.	Pin Name	I/O	Description (説明)
46	O-EVRDATA	O	音量データ出力
47	I-RMC	I	システムリモコン信号入力
48	IC	-	GNDに接続
49	O-MUTE	O	システムミュート出力
50	O-POWER	O	システム電源 ON/OFF 出力
51	O-PB1	O	デッキ1及び2の再生スイッチ出力 L=デッキ1
52	VDD	-	電源入力
53	A/CST2	O	FLセグメント出力 P24/DECK (CST2)スイッチ入力
54	B/CAM2	O	FLセグメント出力 P23/DECK (CAM2)スイッチ入力
55	C/AUTO1	O	FLセグメント出力 P22/DECK (AUTO1)スイッチ入力
56	D/AUTO2	O	FLセグメント出力 P21/DECK (AUTO2)スイッチ入力
57	E/CAM1	O	FLセグメント出力 P20/DECK (CAM1)スイッチ入力
58	F/CST1	O	FLセグメント出力 P19/DECK (CST1)スイッチ入力
59	G/REA	O	FLセグメント出力 P18/DECK (REA)スイッチ入力
60~70	H-R	O	FLセグメント出力 P17-P7
71	-VFL	-	PL表示用電源
72~77	S-X	O	PLセグメント出力 P6-P1
78	O-K-SCAN	O	キー・スキャン出力
79	O-TRYCLS (CD)	O	CDトレイクローズ時データ出力
80	O-TRYOPN (CD)	O	CDトレイオープン時データ出力

IC, LC72131

Pin No.	Pin Name	I/O	Description (説明)																								
1	XIN	I/O	水晶発振子 (7.2MHz) に接続																								
22	XOUT																										
2	NC	-	未使用																								
3	CE	I	IC 起動、“H” でアクティブ																								
4	DI	I	関連キー作動時、CPU (μ PD78044HGF-026-3B9) からデジタルデータ入力																								
5	CLK	I	データDIでクロックする																								
6	DO	O	CPU (μ PD78044HGF-026-3B9) へデジタルデータ出力																								
7	TM-BASE	O	時計用リファレンスクロック信号 (8Hz) を出力																								
8	MONO/BEAT	O	MONO/BEAT スイッチ時 “H” で出力																								
9	$\overline{\text{FM}}/\text{AM}$	O	以下のように “L” または “H” を出力																								
			<table border="1"> <thead> <tr> <th colspan="2">2 BAND</th> <th colspan="3">3 BAND</th> <th colspan="3">3 BAND</th> </tr> <tr> <th>AM</th> <th>FM</th> <th>LW</th> <th>MW</th> <th>FM</th> <th>MW</th> <th>SW</th> <th>FM</th> </tr> </thead> <tbody> <tr> <td>H</td> <td>L</td> <td>H</td> <td>H</td> <td>L</td> <td>H</td> <td>L</td> <td>L</td> </tr> </tbody> </table>	2 BAND		3 BAND			3 BAND			AM	FM	LW	MW	FM	MW	SW	FM	H	L	H	H	L	H	L	L
			2 BAND		3 BAND			3 BAND																			
			AM	FM	LW	MW	FM	MW	SW	FM																	
H	L	H	H	L	H	L	L																				
10	$\overline{\text{MW}}$	O	以下のように “L” または “H” を出力																								
			<table border="1"> <thead> <tr> <th colspan="2">2 BAND</th> <th colspan="3">3 BAND</th> <th colspan="3">3 BAND</th> </tr> <tr> <th>AM</th> <th>FM</th> <th>LW</th> <th>MW</th> <th>FM</th> <th>MW</th> <th>SW</th> <th>FM</th> </tr> </thead> <tbody> <tr> <td>L</td> <td>L</td> <td>H</td> <td>L</td> <td>L</td> <td>L</td> <td>H</td> <td>L</td> </tr> </tbody> </table>	2 BAND		3 BAND			3 BAND			AM	FM	LW	MW	FM	MW	SW	FM	L	L	H	L	L	L	H	L
			2 BAND		3 BAND			3 BAND																			
			AM	FM	LW	MW	FM	MW	SW	FM																	
L	L	H	L	L	L	H	L																				
11	IF-MUTE	O	インターナルカウンタをコントロール																								
12	IFIN	I	ゼネラルパポーズカウンタ入力																								
13	$\overline{\text{TUNE}}$	I	選局時、“L” を受信																								
14	NC	-	未使用																								
15	A MIN	I	AM ローカル発振子周波数信号を受信																								
16	F MIN	I	FM ローカル発振子周波数信号を受信																								
17	VDD	-	IC (+5V) へ電源供給																								
18	PD	O	PLLチャージポンプ出力																								
19	AIN	I	PLLアクティブ低域フィルター用 MOS トランジスター																								
20	AOUT	O																									
21	VSS	-	GND																								

IC BLOCK DIAGRAM

IC, BU4052BCP

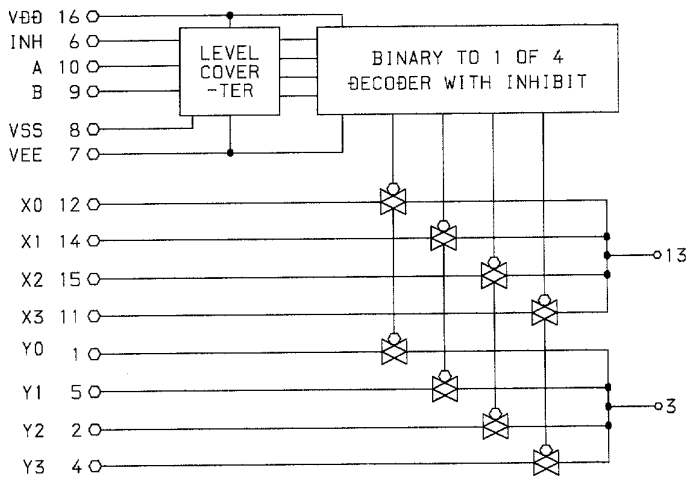

TRUTH TABLE

INHIBIT	A	B	ON SWITCH
L	L	L	X0 Y0
L	H	L	X1 Y1
L	L	H	X2 Y2
L	H	H	X3 Y3
H	X	X	NONE

IC, BU4094BCP

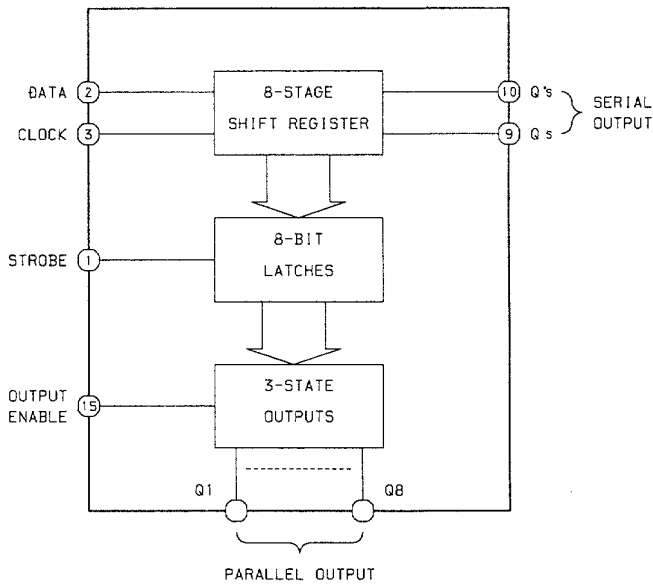

TRUTH TABLE

CLOCK	OUTPUT ENABLE	STROBE	DATA	PARALLEL OUTPUTS		SERIAL OUTPUTS	
				Q1	Qn	Qs	Q's
	L	X	X	Z	Z	Q7	No Chg.
	L	X	X	Z	Z	No Chg.	Qs
	H	L	X	No Chg.	No Chg.	Q7	No Chg.
	H	H	L	L	Qn-1	Q7	No Chg.
	H	H	H	H	Qn-1	Q7	No Chg.
	H	X	X	No Chg.	No Chg.	No Chg.	Qs

Z=High Impedance

X=Don't Care

IC, TA8124P

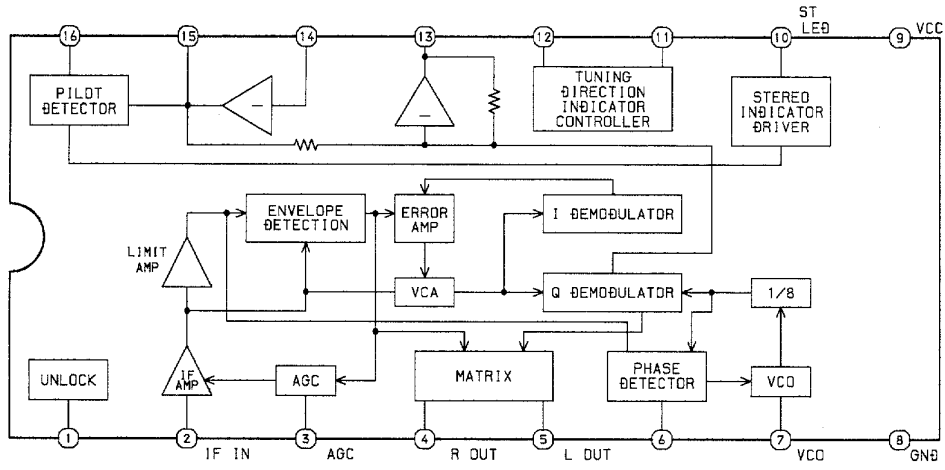

IC, LA1836

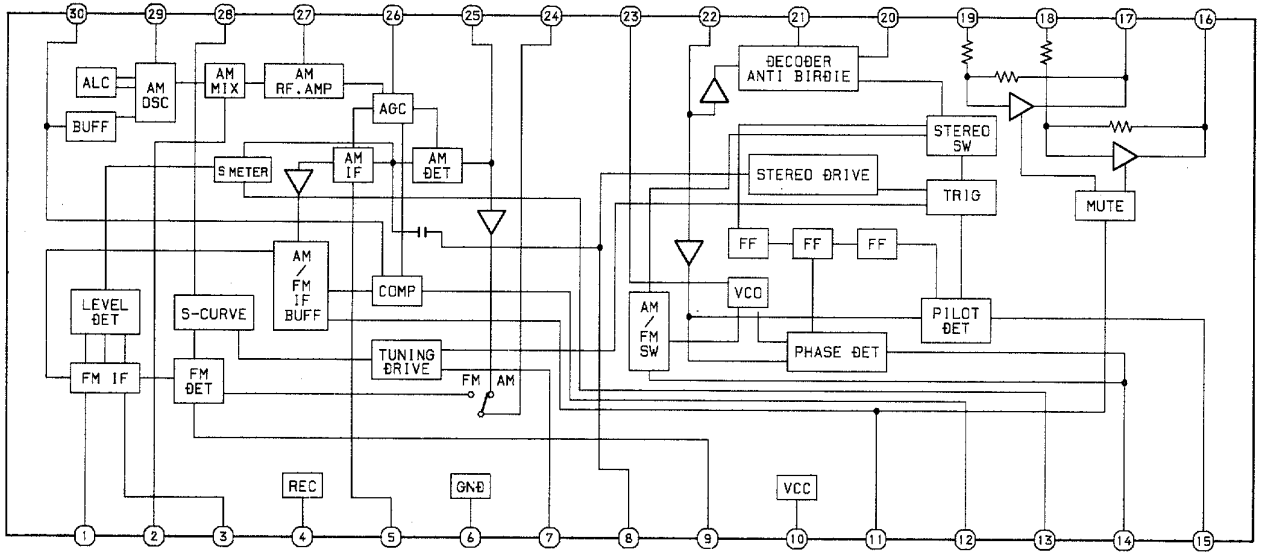

IC, BU1920

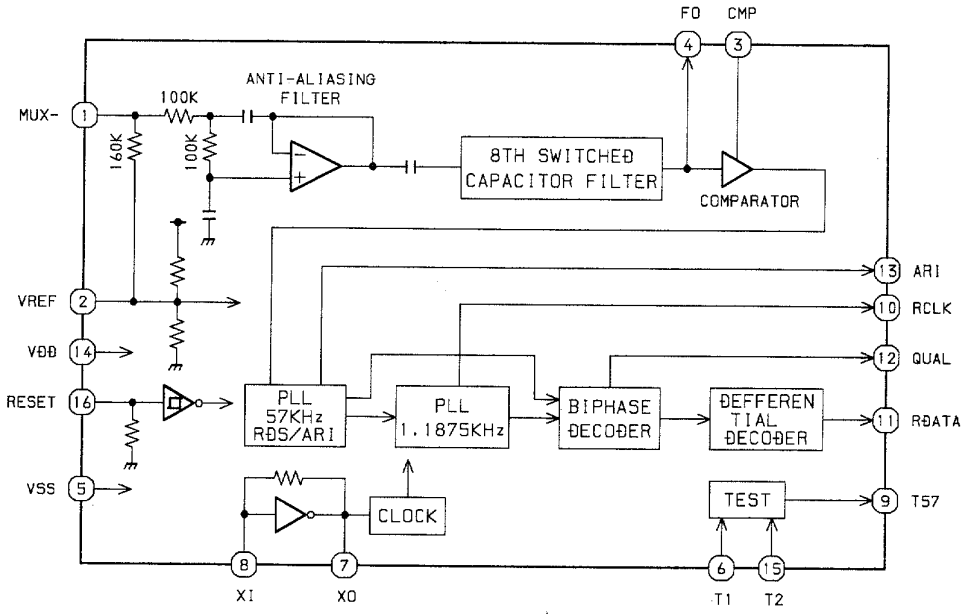

ADJUSTMENT <TUNER / DECK : 22EZ, 23EZ, K, G, V, HR>

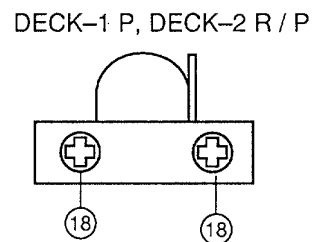
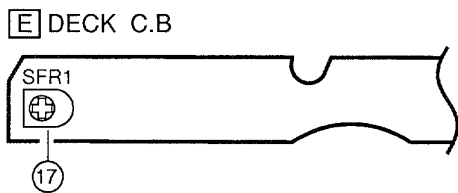
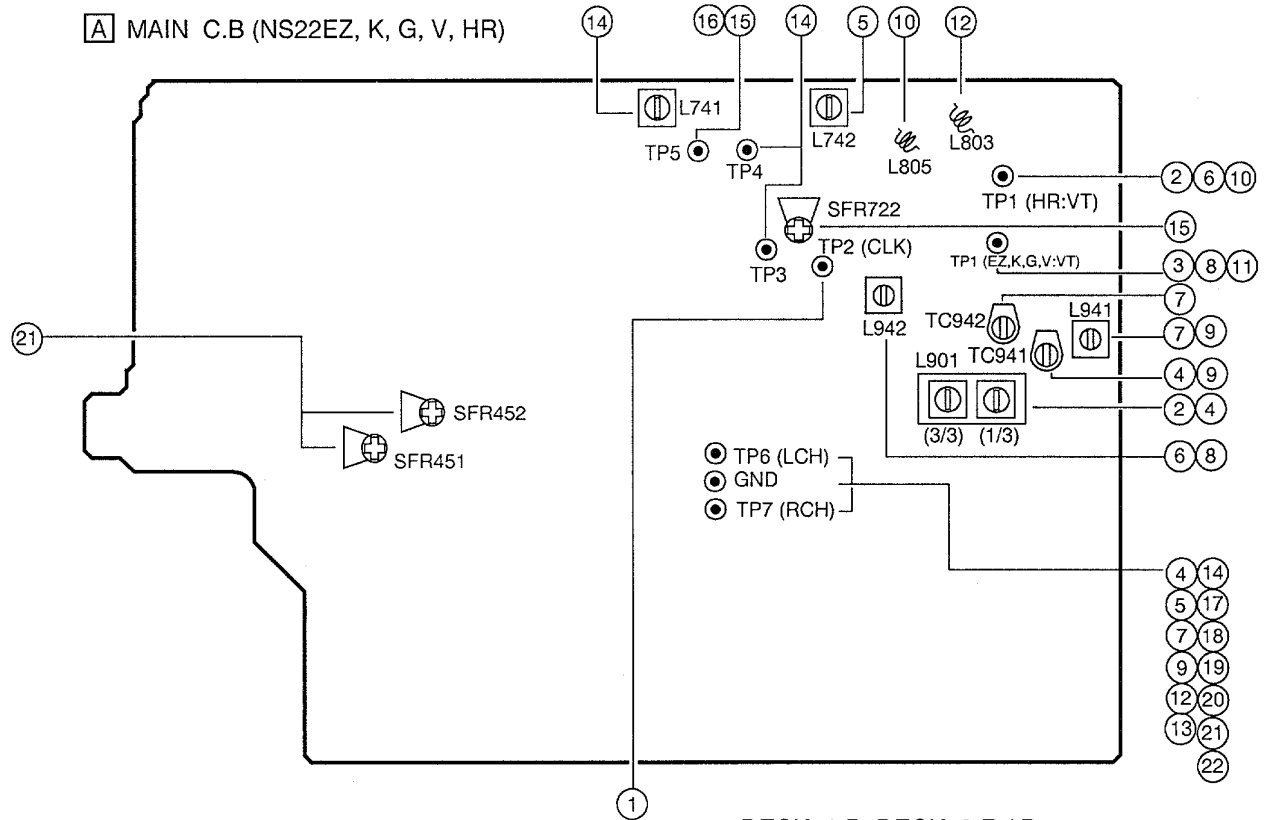
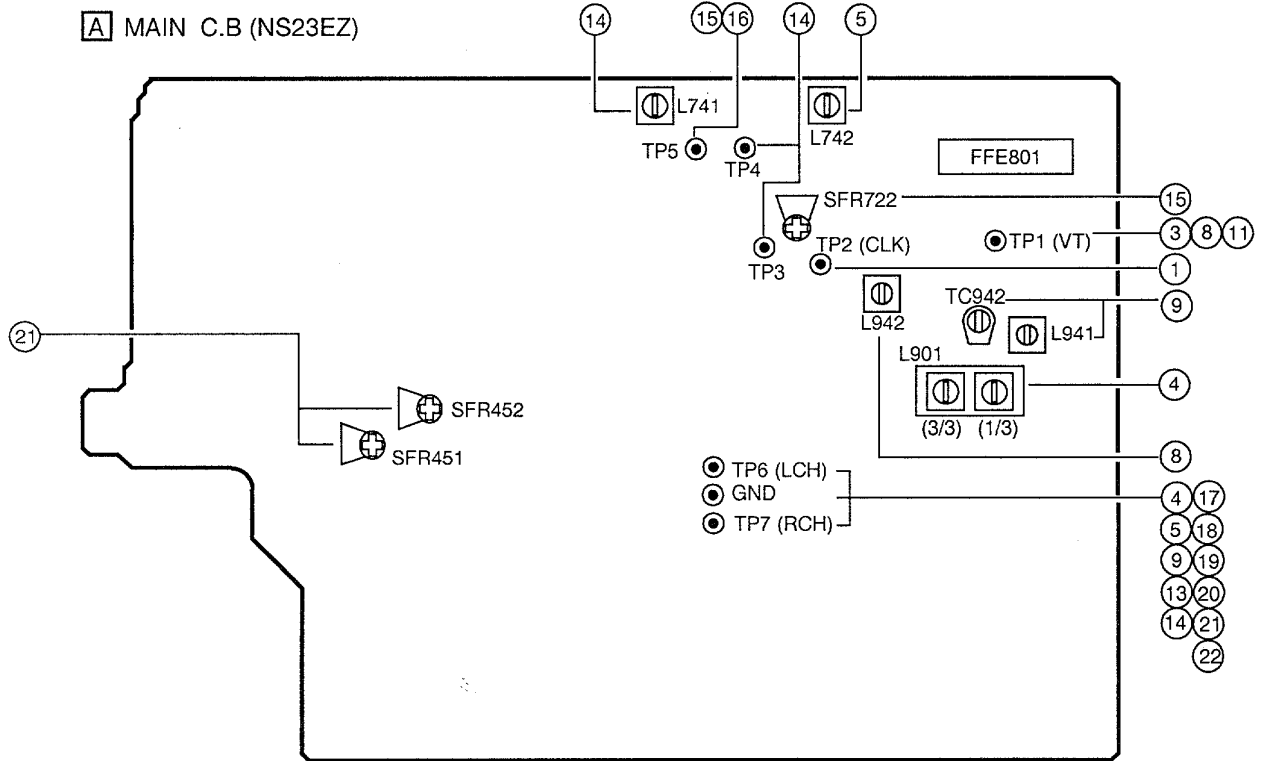

< TUNER SECTION >

1. Clock Frequency Check
Settings : • Test point : TP2 (CLK)
Method : Set to MW(AM) 1602kHz and check that the test point is 2052kHz \pm 0.08kHz.
2. MW VT Adjustment<HR>
Settings : • Test point : TP1 (VT)
• Adjustment location : L901(3/3)
Method : Set to MW 1710kHz and adjust L901(3/3) so that the test point is 8.5V \pm 0.05V.
3. MW VT Check<EZ,K,G,V>
Settings : • Test point : TP1 (VT)
Method : Set to MW 1602kHz and check that the test point is 5.6V \pm 1.0V.
4. MW Tracking Adjustment<EZ,K,G,V>
Settings : • Test point : TP6(Lch), TP7(Rch)
• Adjustment location : L901(1/3)
Method : Set to MW 999kHz and adjust L901(1/3) so that the test point becomes maximum.
4. MW Tracking Adjustment<HR>
Settings : • Test point : TP6(Lch), TP7(Rch)
• Adjustment location :
L901(1/3)603kHz
TC941 1404kHz
Method : Set up TC941 to center before adjustment, the level at 603kHz is adjust to maximum by L901(1/3). Then the level at 1404kHz is adjust to maximum by TC941.
5. AM IF Adjustment
Settings : • Test point : TP6(Lch), TP7(Rch)
• Adjustment location :
L742.....450kHz
6. SW VT Adjustment<HR>
Settings : • Test point : TP1 (VT)
• Adjustment location : L942
Method : Set to SW 17.9MHz and adjust L942 so that the test point is 7.0V \pm 0.05V.
7. SW Tracking Adjustment<HR>
Settings : • Test point : TP6(Lch), TP7(Rch)
• Adjustment location :
L941 5.9MHz
TC942 17.9MHz
Method : Set up TC942 to center before adjustment. The level at 5.9MHz is adjust to maximum by L941. Then the level at 17.9MHz is adjust to maximum by TC942.
8. LW VT Adjustment<EZ,K,G,V>
Settings : • Test point : TP1 (VT)
• Adjustment location : L942
Method : Set to LW 144kHz and adjust L942 so that the test point is 1.3V \pm 0.05V.
9. LW Tracking Adjustment<EZ,K,G,V>
Settings : • Test point : TP6(Lch), TP7(Rch)
• Input level : Adjustable
• Adjustment location :
L941 144kHz
TC941<22EZ,K,G,V> 290kHz
TC942<23EZ> 290kHz
Method : Set up TC941/TC942 to center before adjustment. The level at 144kHz is adjust to MAX by L941. Then the level at 290kHz is adjust to MAX by TC941/TC942.
10. FM VT Adjustment<HR>
Settings : • Test point : TP1 (VT)
• Adjustment location : L805
Method : Set to FM 87.5MHz, 108.0MHz and check that the test point is more than 1.0V(87.5MHz) and adjust L805 so that the test point becomes 7.0V \pm 0.05V (108.0MHz).
11. FM VT Check<EZ,K,G,V>
Settings : • Test point : TP1 (VT)
Method : Set to FM 87.5MHz<EZ,K,G>, 65.0MHz<V> and check that the test point is more than 1.5V<EZ,K,G>, 1.0V<V>. Then set to FM 108MHz and check that the test point is less than 8.2V<EZ,K,G>, 9.5V<V>.
12. FM Tracking Adjustment<HR>
Settings : • Test point : TP6(Lch), TP7(Rch)
• Adjustment location : L803 87.5MHz
Method : The level at 87.5MHz is adjusted by L803 so that the test point is 0 \pm 6dB (87.5MHz) and 4dB \pm 6dB (108.0MHz).
13. FM Tracking Check<EZ,K,G,V>
Settings : • Test point : TP6(Lch), TP7(Rch)
Method : Set to FM 98.0MHz<EZ,K,G>, 70.0MHz<V> and check that the test point is 10dB \pm 6dB<EZ,K,G>, 5dB \pm 6dB<V>.
14. DC Balance / Mono Distortion Adjustment
Settings : • Test point : TP3, TP4 (DC balance)
: TP6, TP7 (Distortion)
• Adjustment location : L741
• Input level : 54dB
Method : Set to FM 98.0MHz and adjust L741 so that the voltage between TP3 and TP4 becomes 0V \pm 0.04V. Next, check that the distortion is less than 3%.
15. Auto Stop Level Adjustment
Settings : • Test point : TP5
• Adjustment location : SFR722
• Input level : 54dB
Method : Set to FM 98.0MHz and adjust voltage low (about 0.1V) by SFR722. After that voltage high (about 7.0V) by 2dB down.
16. Auto Stop Level Check
MW
Settings : • Test point : TP5
• Input level : 54dB
Method : Set to AM 999kHz and check that the test point is 58 +10/-15dB.

SW<HR>
Settings : • Test point : TP5
• Input level : 54dB
Method : Set to SW 12.0MHz and check that the test point is 45dB \pm 10dB.

FM
Settings : • Test point : TP5
• Input level : 54dB
Method : Set to FM 98.0MHz and check that the test point is 20dB +10/-5dB.

< DECK SECTION >

17. Tape Speed Adjustment

- Settings : • Test tape : TTA-410
• Test point : TP6, TP7
• Adjustment location : SFR1

Method : Play back the test tape and adjust SFR1 so that the frequency counter reads 3000Hz \pm 5Hz.

18. Head Azimuth Adjustment

- Settings : • Test tape : TTA-410
• Test point : TP6, TP7
• Adjustment location : Head azimuth adjustment screw

Method : Play back the 10kHz signal of the test tape and adjust screw so that the output becomes maximum. Next, perform on each FWD and REV PLAY mode.

19. PB Frequency Response Check (DECK 1, DECK 2)

- Settings : • Test tape : TTA-410
• Test point : TP6, TP7

Method : Play back the 315Hz and 10kHz signals of the test tape and check that the output ratio of the 10kHz signal with respect to that of the 315Hz signal is 0 ± 5 dB

20. PB Sensitivity Check (DECK 1, DECK 2)

- Settings : • Test tape : TTA-200
• Test point : TP6, TP7

Method : Play back the test tape and check that the output level of the test point is 150mV \pm 3.0dB .

21. REC/PB Frequency Response Adjustment

- Settings : • Test tape : TTA-602
• Test point : TP6, TP7
• Input signal : 1kHz / 10kHz (LINE IN)
• Adjustment location : SFR451 (Lch)
SFR452 (Rch)

Method : Apply a 1kHz signal and REC mode. Then adjust OSC attenuator so that the output level at the TP6, TP7 becomes 11mV. Record and play back the 1kHz and 10kHz signals and adjust SFRs so that the output of the 10kHz signals becomes 12mV (+1.0dB) \pm 0.5dB with respect to that of the 1kHz signal.

22. REC/PB Sensitivity Check

- Settings : • Test tape : TTA-602
• Test point : TP6, TP7
• Input signal : 1kHz (LINE IN)

Method : Apply a 1kHz signal and REC mode. Then adjust OSC attenuator so that the output level at the TP6, TP7 becomes 11mV. Record and play back the 1kHz signals and check that the output is 10mV (-1.0dB) \pm 2.5dB.

ADJUSTMENT <TUNER / DECK : D>

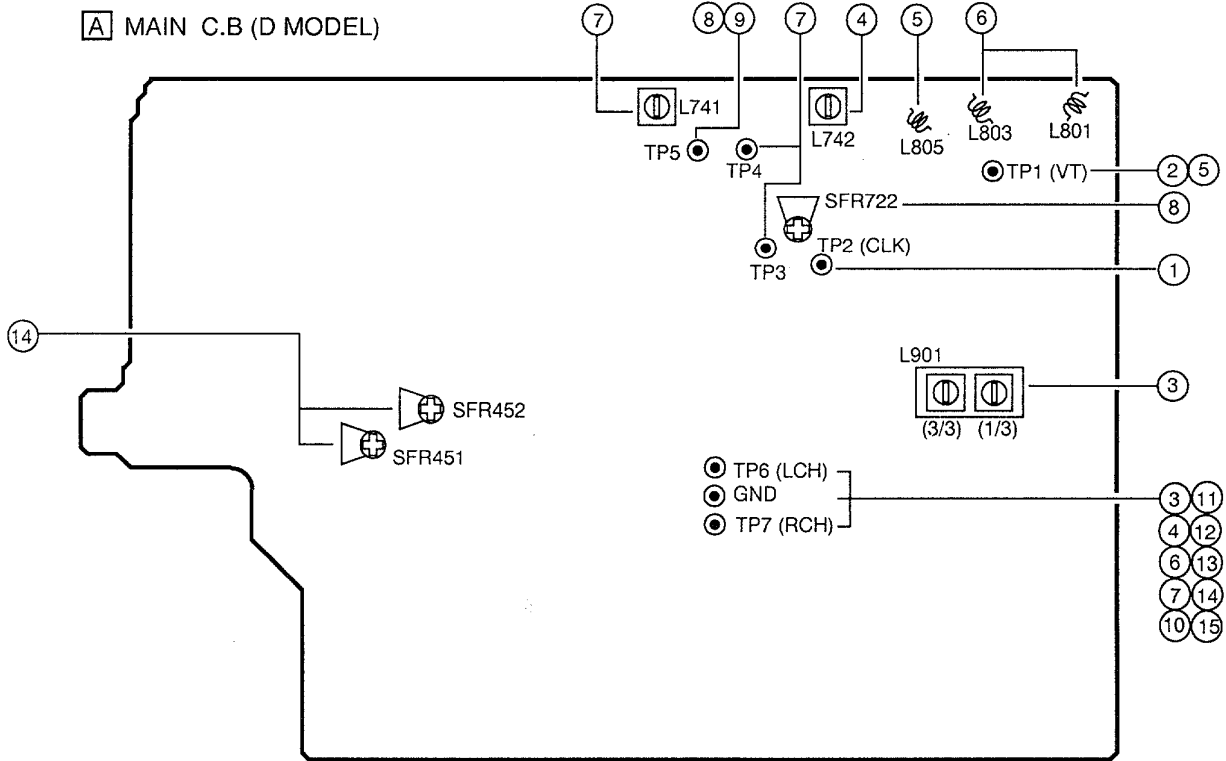

E DECK C.B

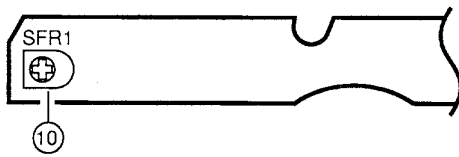

DECK-1 P, DECK-2 R / P

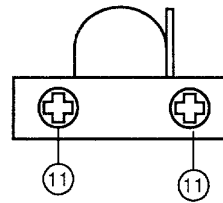

< TUNER SECTION >

1. クロック周波数確認
条件： ・テストポイント：TP2
方法： AM1602kHzにセットし、テストポイントの周波数が2052kHz \pm 0.08kHzになることを確認する。
2. AM VT 確認
条件： ・テストポイント：TP1(VT)
方法： AM1602kHzにセットし、テストポイントの電圧が5.6 \pm 1.0Vになることを確認する。
3. AMトラッキング調整
条件： ・テストポイント：TP6,TP7
・調整箇所：L901(1/3)
方法： AM999kHzにセットし、感度が最大になるようにL901 (1/3) を調整する。
4. AM IF 調整
条件： テストポイント：TP6,TP7
・調整箇所
L742……………450kHz
5. FM VT 調整
条件： ・テストポイント：TP1 (VT)
・調整箇所：L805
方法： FM76.0MHz, 108.0MHzにセットし、テストポイントが0.4V(76.0MHz)以上であることを確認後、L805で8.0V \pm 0.05V(108.0MHz)になるように調整する。
6. FMトラッキング調整
条件： ・テストポイント：TP6,TP7
・調整箇所：L801,L803……83.0MHz
方法： FM83.0MHzにセットし、テストポイントが最大になるように、L801,L803を調整する。次に、テストポイントが2dB \pm 6dB (76.0MHz)及び4dB \pm 6dB (108.0MHz)であることを確認する。
7. DCバランス / モノ歪率調整
条件： ・テストポイント：TP3,TP4 (DCバランス)
TP6,TP7 (モノ歪率)
・調整箇所：L741
・入力レベル：54dB
方法： FM83.0MHzにセットしTP3,TP4間の電圧が0V \pm 0.04VになるようにL741を調整する。調整後、歪率が1.3%以下であることを確認する。
8. オートストップレベル調整
条件： ・テストポイント：TP5
・調整箇所：SFR722
・入力レベル：54dB
方法： FM83.0MHzにセットし、TP5の電圧が約0.1VになるようにSFR722を調整する。その後、入力レベルを2dB下げTP5の電圧が約7.0Vになる様調整する。

9. オートストップレベル確認
AM
条件： ・テストポイント：TP5
・入力レベル：54dB
方法： AM999kHzにセットし、TP5が43dB \sim 68dBであることを確認する。

FM
条件： ・テストポイント：TP5
・入力レベル：54dB
方法： FM83.0MHzにセットし、TP5が20dB+10/-5dBであることを確認する。

< DECK SECTION >

10. テープスピード確認
条件： ・テストテープ：TTA-410
・テストポイント：TP6,TP7
・調整箇所：SFR1
方法： テストテープを再生し、周波数カウンタが3000Hz \pm 5HzになるようSFR1を調整する。
11. アジマス調整
条件： ・テストテープ：TTA-410
・テストポイント：TP6,TP7
・調整箇所：アジマス調整ネジ
方法： テストテープの10kHzを再生し、出力が最大になるようアジマス調整ネジを調整する。次にREV PLAYも同様の方法で調整する。
12. 再生周波数特性確認 (デッキ1, デッキ2)
条件： ・テストテープ：TTA-410
・テストポイント：TP6,TP7
方法： テストテープの315Hz, 10kHzを再生し10kHzと315Hzの出力差が \pm 5dBであることを確認する。
13. 再生感度確認 (デッキ1, デッキ2)
条件： ・テストテープ：TTA-200
・テストポイント：TP6,TP7
方法： テストテープのを再生し、テストポイントの出力が150mV \pm 3dBであることを確認する。
14. 録再周波数特性確認 (デッキ1, デッキ2)
条件： ・テストテープ：TTA-602
・テストポイント：TP6,TP7
・入力信号：1kHz/8kHz (LINE IN)
・調整箇所：SFR451(Lch)
SFR452(Rch)
方法： 1kHzの信号をRECモードで入力する。TP6,TP7の出力レベルが11mVになるようOSCアッテネータを調整する。テストテープに1kHz, 10kHz信号を録再し、1kHzの信号に対し、10kHzの出力レベルが12mV (+1.0dB) \pm 0.5dBであることを確認する。
15. 録再感度確認
条件： ・テストテープ：TTA-602
・テストポイント：TP6,TP7
・入力信号：1kHz (LINE IN)
方法： 1kHzの信号をRECモードで入力する。TP6,TP7の出力レベルが11mVになるようOSCアッテネータを調整する。テストテープに1kHz信号を録再し、出力信号が10mV (-1.0dB) \pm 2.5dBであることを確認する。

PRACTICAL SERVICE FIGURE

<TUNER SECTION>

<FM SECTION>

IHF Sensitivity : 3dB ± 6dB<HR>
 (THD 3%) [at 87.5MHz]
 2dB ± 6dB<HR>
 [at 98.0MHz]
 2dB +8/-4dB<HR>
 [at 108.0MHz]
 11dB ± 6dB<EZ,K,G>
 [at 87.5 / 98.0 / 108.0MHz]
 10dB ± 6dB<V>
 [at 65.0MHz]
 4dB ± 6dB<V>
 [at 70.0MHz]
 5dB ± 6dB<V>
 [at 74.0MHz]
 3dB ± 6dB<D>
 [at 76.0 / 83.0MHz]
 4dB ± 8dB<D>
 [at 108.0MHz]

S/N 50dB Quieting sensitivity :

Less than 35dB<HR,V>
 Less than 36dB<EZ,K,G>
 [at 87.5 / 98.0 / 108.0MHz]
 Less than 35dB<D>
 [at 76.0 / 83.0 / 108.0MHz]

Signal to noise ratio : More than 60dB (STEREO)
 More than 70dB (MONO)<HR,D>
 More than 67dB (MONO)<EZ,K,G,V>
 [at 98.0MHz]<Except D>
 [at 83.0MHz]<D>

Distortion : Less than 2.0% (STEREO)
 Less than 1.3% (MONO)
 [at 98.0MHz]<Except D>
 [at 83.0MHz]<D>

Auto stop level : 20dB +10/-5dB
 [at 98.0MHz]<Except D>
 [at 83.0MHz]<D>

Stereo separation : More than 28dB<HR,D>
 [at 98.0MHz]<HR>
 [at 83.0MHz]<D>
 More than 20dB<EZ,K,G,V>
 [at 98.0MHz]

Intermediate frequency : 10.7MHz

<AM(MW) SECTION>

Sensitivity : 52 ~ 64dB
 (S/N 20 dB) [at 603kHz]
 46 ~ 58dB
 [at 999 / 1404kHz]

Signal to noise ratio : More than 30dB
 [at 999kHz]

Distortion : Less than 1.5%
 [at 999kHz]

Auto stop level : 58dB +10/-15dB
 [at 999kHz]

Stereo separation : More than 12dB<D>
 [at 999kHz]

Intermediate frequency : 450kHz

<AM(LW) SECTION><EZ,K,G,V>

Sensitivity : Less than 72dB
 (S/N 20 dB) [at 144kHz]
 Less than 69dB
 [at 198kHz]
 Less than 67dB
 [at 290kHz]

Intermediate frequency : 450kHz

<AM(SW) SECTION><HR>

Sensitivity : 42dB ± 5dB
 (S/N 20 dB) [at 5.9MHz]
 36dB ± 5dB
 [at 12.0 / 17.9MHz]
 Less than 67dB
 [at 290kHz]

Intermediate frequency : 450kHz

<DECK SECTION>

Tape speed : 3000Hz ± 45Hz
 Wow & flutter : Less than 0.25%
 (W.R.M.S)

Take-up torque : 30 ~ 55g-cm
 (FWD, REV)

F.F & REW torque : 75 ~ 180g-cm
 Back tension : 2 ~ 7g-cm
 (FWD, REV)

PB output level : 2.8V ± 3dB
 (SP OUT 2V)

REC/PB output level : 2.0V ± 3.5dB
 (SP OUT 2V, 0VU)

Distortion (REC/PB) : Less than 2.0%
 (NORMAL, 0VU)

Noise level (PB) : Less than 25mV
 (NORM, SP OUT 2V)

Noise level (REC/PB) : Less than 30mV
 (NORM, SP OUT 2V, 0VU)

Crosstalk : More than 55dB
 (1kHz, NORMAL)

Channel separation : More than 35dB
 (1kHz)

Erasing ratio : More than 55dB
 (at 125Hz, 10VU, NORMAL)

Test tape : TTA-602 (NORMAL)

MECHANICAL EXPLODED VIEW 1 / 1

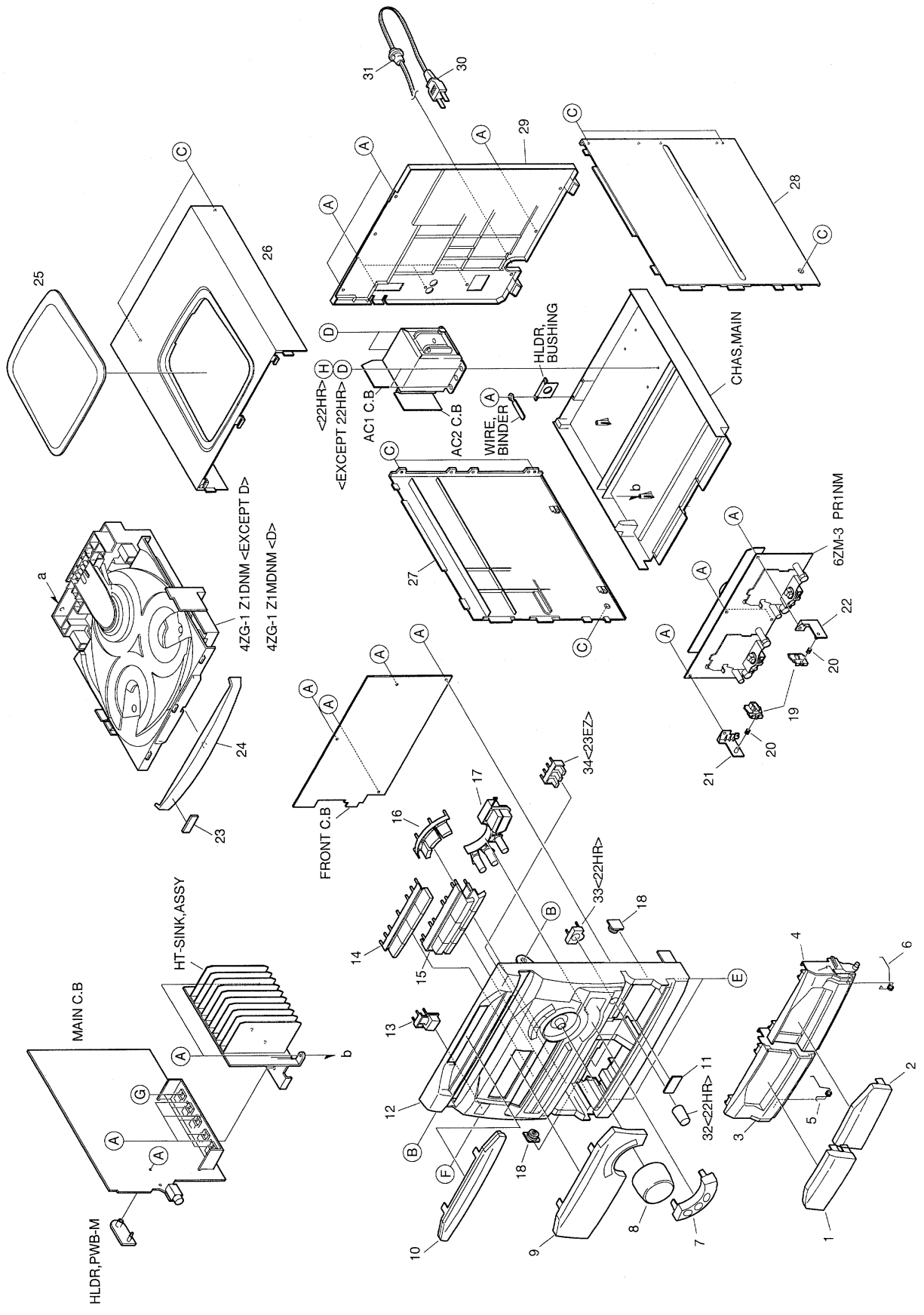

MECHANICAL PARTS LIST 1 / 1

If can't understand for Description please kindly refer to "REFERENCE NAME LIST".

REF. NO.	PART NO.	KANRI NO.	DESCRIPTION	REF. NO.	PART NO.	KANRI NO.	DESCRIPTION
1	87-NF8-014-010	1A	WINDOW, CASS 1	26	87-NF8-045-010	2B	PANEL, TOP ST
2	87-NF8-015-010	1A	WINDOW, CASS 2	27	87-NF8-042-010	1C	PANEL, LEFT 2 ST
3	87-NF8-003-010		BOX, CASS 1<EXCEPT 22HR, 22D>	28	87-NF8-044-010	1C	PANEL, RIGHT 2 ST
3	87-NF8-061-010	1B	BOX, CASS 1D<22D>	29	87-NF8-051-010		CABI, REAR EZSTNM<22EZ>
3	87-NF8-025-010		BOX, CASS 1H<22HR>	29	87-NF8-038-010		CABI, REAR GSTNM<22G>
4	87-NF8-004-010		BOX, CASS 2<EXCEPT 22HR, 22D>	29	87-NF8-053-010		CABI, REAR HRSTNM<22HR>
4	87-NF8-062-010	1B	BOX, CASS 2D<22D>	29	87-NF8-052-010		CABI, REAR KSTNM<22K>
4	87-NF8-026-010		BOX, CASS 2H<22HR>	29	87-NF8-035-010	1C	CABI, REAR STNM<22D>
5	82-NF5-218-010	0E	SPR-T, EJECT 1 (SIN)	29	87-NF8-040-010		CABI, REAR EZSTNM RDS<23EZ >
6	82-NF5-219-010	0E	SPR-T, EJECT 2 (SIN)	29	87-NF8-034-010		CABI, REAR VJSTNM<22V>
7	87-NF8-019-010	1A	PANEL, CD	△	30	87-050-098-010	1B AC CODE ASSY, D<22D>
8	87-NF8-012-010	1A	KNOB, RTRY VOL	△	30	87-050-081-110	AC CORD ASSY, G<22G>
9	87-NF8-013-010	1C	WINDOW, DISPLAY<EXCEPT 23EZ >	△	30	87-A80-007-110	AC CORD ASSY, K BLK<22K>
9	87-NF8-028-010		WINDOW, DISPLAY RDS<23EZ >	△	30	87-050-079-010	AC-CORD ASSY<EXCEPT 22G, 22K, 22D>
10	87-NF8-016-010	1B	WINDOW, CD	31	87-085-184-010	0E	BUSHING, AC CORD (D)<22D>
11	81-532-080-010	1A	LABEL, CASS. COMPT	31	87-085-185-010		BUSHING, AC CORD (E)<EXCEPT 22D>
12	87-NF8-024-110	1H	CABI, FR D<22D>	32	87-NF7-021-010		KNOB, RTRY MIC<22HR>
12	87-NF8-021-110		CABI, FR HR<22HR>	33	87-NF8-020-010		PLATE, MIC<22HR>
12	87-NF8-023-110		CABI, FR K<22G, 22K, 22EZ, 22V>	34	87-NF8-011-010		KEY, RDS<23EZ >
12	87-NF8-027-110		CABI, FR RDS<23EZ >	A	87-067-703-010	0E	TAPPING SCREW, BVT2+3-10
13	87-NF8-005-010		KEY, POWER<EXCEPT 22D>	B	87-721-097-410	0E	QT2+3-12 GLD
13	87-NF8-063-010	0E	KEY, POWER D<22D>	C	87-B10-091-010	0E	UTT2+3-10 W/O BLK
14	87-NF8-008-010	1B	KEY, FUN	D	87-741-172-410	0E	UT2+4-12 W/O SLOT
15	87-NF8-010-010	1B	KEY, OPE	E	87-067-758-010	0E	BVT2+3-12 W/O SLOT
16	87-NF8-007-010	1B	KEY, GEQ	F	87-723-096-410	0E	QT2+3-10W/O SLOT BL
17	87-NF8-006-010	1B	KEY, CD	G	87-067-579-010	0E	TAPPING SCREW, BVT2+3-8
18	87-NF8-220-010	0E	DMPR, OIL	H	87-743-175-410		UT2+4-16<22HR>
19	82-NF5-229-010	0E	PLATE, LOCK				
20	82-NF5-228-010	0E	SPR-C, LOCK				
21	87-NF4-216-010	0E	HLDR, LOCK 1				
22	87-NF4-217-010	0E	HLDR, LOCK 2				
23	82-NE6-067-010	1A	BADGE, AIWA 30N				
24	87-NF8-018-010		PANEL, TRAY<EXCEPT 22D>				
24	87-NF8-064-010	1B	PANEL, TRAY D<22D>				
25	86-NFZ-001-010	1B	WINDOW, TOP				

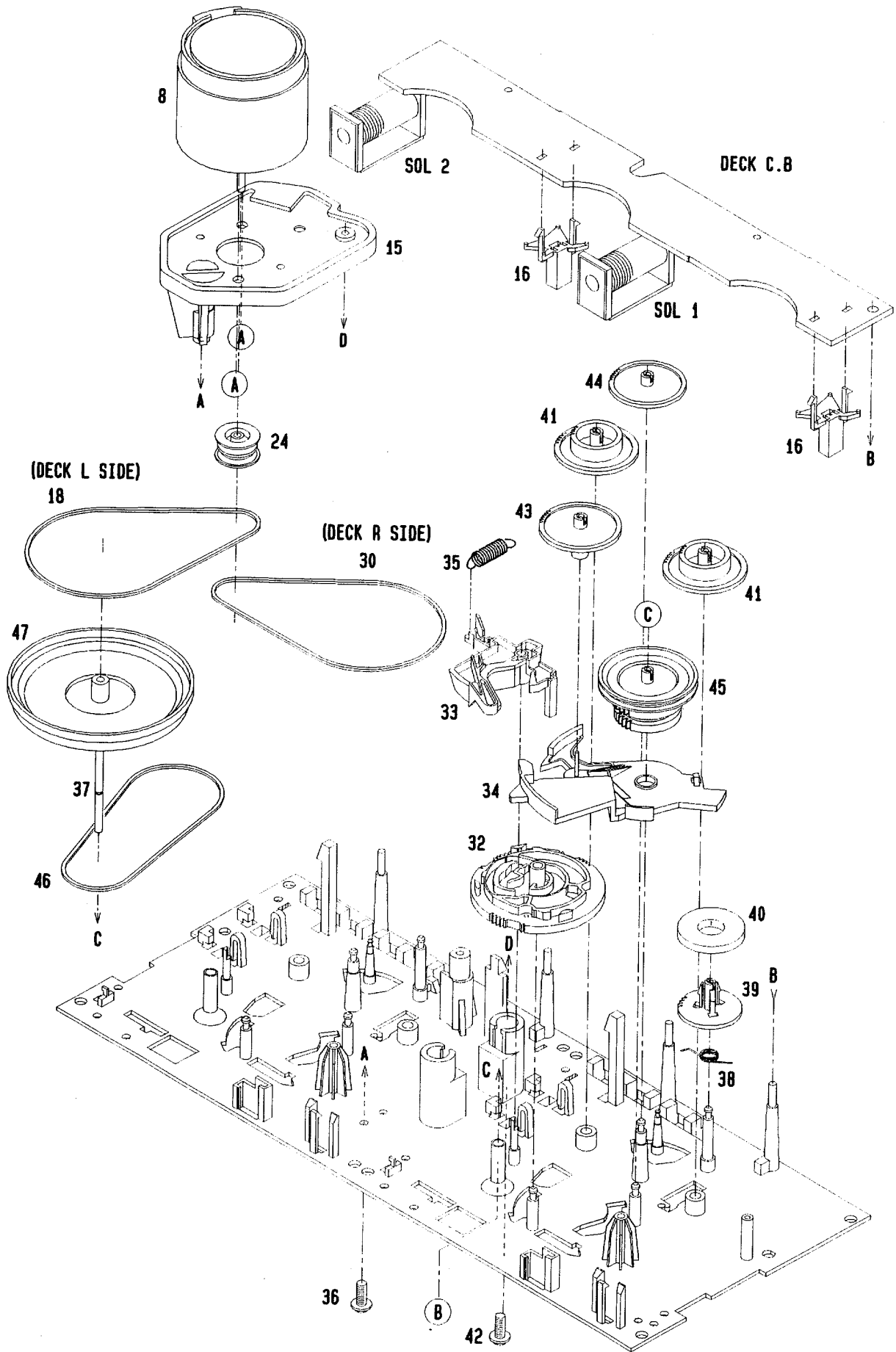

TAPE MECHANISM PARTS LIST 1 / 1

If can't understand for Description please kindly refer to "REFERENCE NAME LIST".

REF. NO.	PART NO.	KANRI NO.	DESCRIPTION	REF. NO.	PART NO.	KANRI NO.	DESCRIPTION
1	86-ZM3-212-010	--	CHAS ASSY,SS	26	82-ZM1-243-019	0E	LVR,STOP
2	86-ZM3-202-010	0E	BASE,HEAD S	27	82-ZM1-344-119	1A	LVR ASSY,PINCH
3	86-ZM3-205-010	0E	SPR-C,RPH S	28	86-ZM3-204-010	0E	SPR-T,PINCHDS
4	82-ZM1-333-210	0E	PLATE,LINK 2	29	82-ZM1-240-119	0E	LVR,REC (DECK 2)
5	86-ZM3-206-010	0E	SPR-C,EH S	30	86-ZM3-210-010	0E	BELT,RS
6	87-A90-403-019	1B	HEAD,RPH MS15R	32	82-ZM3-305-119	0E	GEAR,CAM M2
7	86-ZM3-201-010	1A	CHAS,HEAD S	33	82-ZM1-227-319	0E	LVR,TRIG
8	87-045-347-019	1H	MOT,SHU2L 70(M1)	34	82-ZM3-306-110	0E	LVR,FR M2
9	82-ZM1-269-219	0E	SPR-T,BRG	35	82-ZM1-265-119	0E	SPR-E,TRIG
10	82-ZM1-219-110	0E	SPR-T,LINK	36	87-761-073-419	0E	VFT2+2.6-6 W/O SLOT
11	86-ZM3-209-010	0E	S-SCREW,ASIMUTHS	37	82-ZM1-239-019	0E	CAPSTAN N 2.2-41.7
12	86-ZM3-207-010	0E	S-SCREW,RPH	38	82-ZM1-322-019	0E	SPR-T,FR60
13	87-A90-404-019	0E	HEAD,EH LEL5B	39	82-ZM1-220-219	0E	GEAR,IDLER
14	86-ZM3-208-010	0E	S-SCREW,EH	40	82-ZM3-616-019	0E	RING MAGNET 4
15	86-ZM3-203-010	1B	HLDR,MOTS	41	82-ZM1-216-319	0E	GEAR,REEL
16	82-ZM1-245-210	0E	HLDR,IC	42	86-ZM3-213-010	0E	S-SCREW,HLDR,MOT 3
17	82-ZM1-218-019	0E	SPR-E,HB	43	82-ZM1-225-219	0E	GEAR,FR
18	82-ZM3-211-010	0E	BELT,RS	44	82-ZM1-226-019	0E	GEAR,REW
19	82-ZM1-222-219	0E	LVR,PLAY	45	82-ZM3-333-310	1B	SLIP DISK ASSY 2
20	82-ZM1-217-419	0E	REEL TABLE	46	82-ZM1-338-010	0E	BELT FR4
21	82-ZM1-244-519	0E	SPR-C,BT	47	82-ZM1-349-019	1A	FLY-WHL RW (DECK L)
22	82-ZM1-285-410	0E	SPR-C,BT L	47	82-ZM3-331-019	1A	FLY-WHL R2W (DECK R)
23	82-ZM1-257-019	0E	SPR-T,CAS	A	87-251-071-417	0E	U+2.6-4
24	82-ZM3-221-010	0E	PULLEY,MOT 2M	B	80-ZM6-243-019	0E	SH,1.75-3.6-0.5 SLT
25	82-ZM1-242-019	0E	LVR,CAS	C	82-ZM3-334-010	0E	PW,2.16-6-0.4

SPRING APPLICATION POSITION

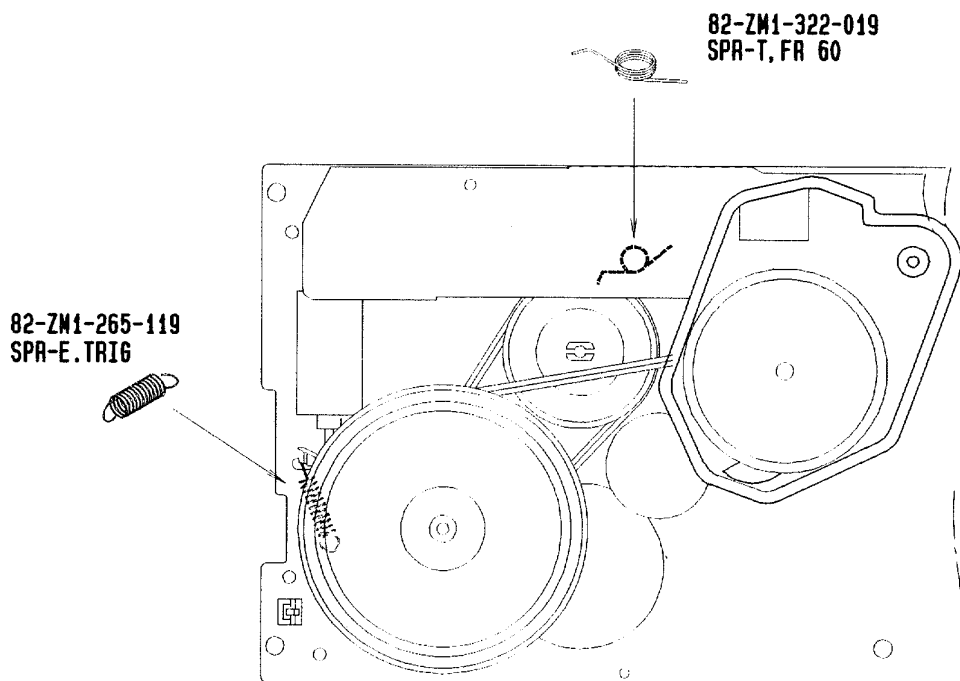
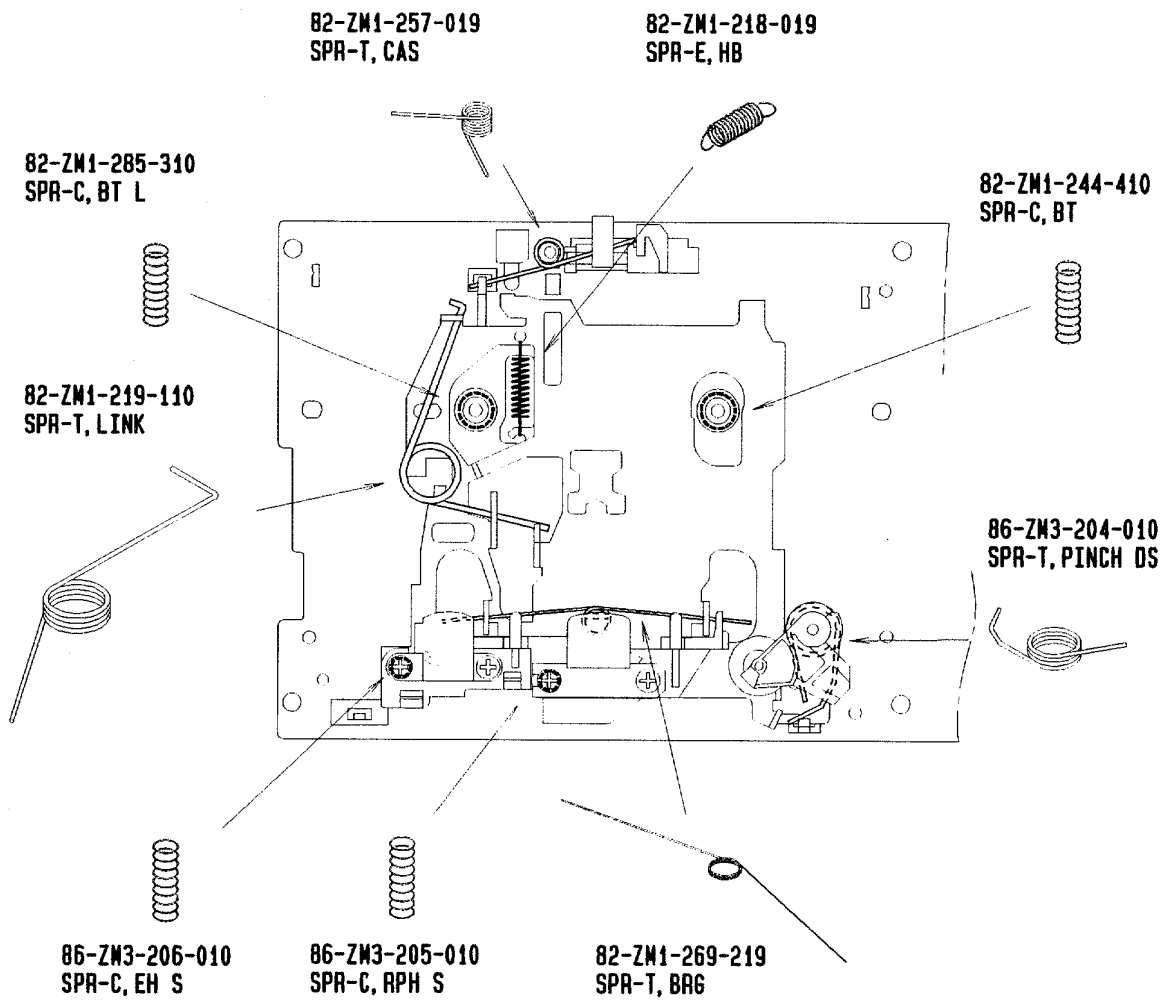

SPEAKER DISASSEMBLY INSTRUCTIONS

Type.1

矢印の位置にマイナスドライバーを差し込んで、パネルを外します。各々のスピーカーユニットのビスを取り、スピーカーユニットを外してください。

Insert a flat-bladed screwdriver into the position indicated by the arrows and remove the panel. Remove the screws of each speaker unit and then remove the speaker units.

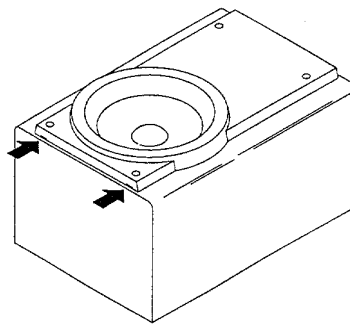

Type.2

グリルフレームを外し、4個のゴムキャブをマイナスドライバーで端の方から持ち上げて外すと中にビスがありますので、ビスを取り外します。矢印の位置にマイナスドライバーを差し込んで、パネルを外します。各々のスピーカーユニットのビスを取り、スピーカーユニットを外してください。

Remove the grill frame and four pieces of rubber caps by pulling out with a flat-bladed screwdriver. Remove the screws from hole where installed rubber caps. Insert a flat-bladed screwdriver into the position indicated by the arrows and remove the panel. Remove the screws of each speaker unit and then remove the speaker units.

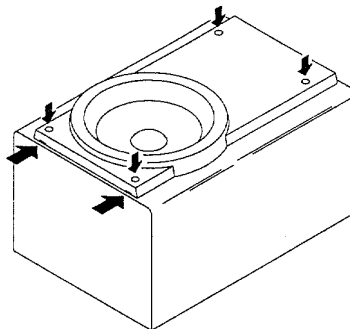

Type.3

矢印の位置にマイナスドライバーを差し込んで、パネルを外します。各々のスピーカーユニットの凹にマイナスドライバーを差し込んで、反時計方向に回転させスピーカーユニットを外してください。スピーカーユニット交換後は時計方向にクリック音がするまで、回転させて取り付けます。

Insert a flat-bladed screwdriver into the position indicated by the arrows and remove the panel. Turn the speaker unit to counter-clockwise direction while inserting a flat-bladed screwdriver into one of the hollows around speaker unit, and then remove the speaker unit. After replacing the speaker unit, install it turning to clockwise direction until "click" sound comes out.

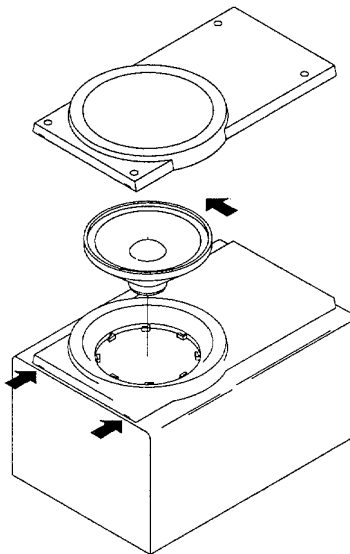

SPEAKER PARTS LIST 1 / 1 (SX-NS22)

If can't understand for Description please kindly refer to "REFERENCE NAME LIST".

REF. NO.	PART NO.	KANRI NO.	DESCRIPTION
1	87-NSH-001-019		PANEL, FR R
2	87-NSH-002-019		PANEL, FR L
3	87-NSH-005-019		NET
4	87-NS7-611-019		CORD, SPKR
5	87-NSJ-602-019		SPKR, 120
6	86-NSZ-602-019		SPKR, CERA 14

ACCESSORIES / PACKAGE LIST

If can't understand for Description please kindly refer to "REFERENCE NAME LIST".

REF. NO.	PART NO.	KANRI NO.	DESCRIPTION
1	87-NF8-918-010	--	IB, D(J)M<D>
1	87-NF8-916-010		IB, E(EGFSI)M<NS22EZ>
1	87-NF8-917-010		IB, E(EGFSI)M NS23(RDS)<NS23EZ>
1	87-NF8-901-010		IB, H(ECA)M<HR>
1	87-NF8-915-010		IB, K(E)M<G, K>
1	87-NF8-907-010		IB, V(ERHPCH)M<V>
2	86-NFZ-638-110	--	RC UNIT, 6AS14
3	87-006-225-010		AM LOOP ANT NC2<G, K, NS22EZ, NS23EZ>
3	87-006-226-010	--	AM-LOOPANT C0<D>
3	87-A90-054-010		ANT, LOOP AM-CON C<HR, V>
4	87-043-095-010		WIRE ANTENNA<HR>
4	87-043-106-010		WIRE, FM ANT (Z)<G, K, NS22EZ, NS23EZ>
5	87-043-115-010		ANT, FEEDER FM<HR>
6	87-A90-312-010		PLUG, CONVERSION WTN-1157R1<HR>

REFERENCE NAME LIST

ELECTRICAL SECTION

DESCRIPTION	REFERENCE NAME
ANT	ANTENNAS
C-	CHIP
C-CAP	CAP, CHIP
C-CAP TN	CAP, CHIP TANTALUM
C-COIL	COIL, CHIP
C-DI	DIODE, CHIP
C-DIODE	DIODE, CHIP
C-FET	FET, CHIP
C-FOTR	FILTER, CHIP
C-JACK	JACK, CHIP
C-LED	LED, CHIP
C-RES	RES, CHIP
C-SFR	SFR, CHIP
C-SLIDE SW	SLIDE SWITCH, CHIP
C-SW	SWITCH, CHIP
C-TR	TRANSISTOR, CHIP
C-VR	VOLUME, CHIP
C-ZENER	ZENER, CHIP
CAP, CER	CAP, CERA-SOL
CAP, E	CAP, ELECT
CAP, M/F	CAP, FILM
CAP, TC	CAP, CERA-SOL
CAP, TC-U	CAP, CERA-SOL SS
CAP, TN	CAP, TANTALUM
CERA FIL	FILTER, CERAMIC
CF	FILTER, CERAMIC
DL	DELAY LINE
E/CAP	CAP, ELECT
FILT	FILTER
FLTR	FILTER
FUSE RES	RES, FUSE
MOT	MOTOR
P-DIODE	PHOTO DIODE
P-SNSR	PHOTO SENSER
P-TR	PHOTO TRANSISTOR
POLY VARI	VARIABLE CAPACITOR
PPCAP	CAP, PP
PT	POWER TRANSFORMER
PTR, RES	PTR, MELF
RC	REMOTE CONTROLLER
RES NF	RES, NON-FLAMMABLE
RESO	RESONATOR
SHLD	SHIELD
SOL	SOLENOID
SPKR	SPEAKER
SW, LVR	SWITCH, LEVER
SW, RTRY	SWITCH, ROTARY
SW, SL	SWITCH, SLIDE
TC CAP	CAP, CERA-SOL
THMS	THERMISTOR
TR	TRANSISTOR
TRIMER	CAP, TRIMMER
TUN-CAP	VARIABLE CAPACITOR
VIB, CER	RESONATOR, CERAMIC
VIB, XTAL	RESONATOR, CRYSTAL
VR	VOLUME
ZENER	DIODE, ZENER
サージサプレッサ	SERGE SUPPRESSOR
セラコン	CAP, CERA

MECHANICAL SECTION

DESCRIPTION	REFERENCE NAME
ADHESHIVE	SHEET ADHESHIVE
AZ	AZIMUTH
BAR-ANT	BAR-ANTENNA
BAT	BATTERY
BATT	BATTERY
BRG	BEARING
BTN	BUTTON
CAB	CABINET
CASS	CASSETTE
CHAS	CHASSIS
CLR	COLLAR
CONT	CONTROL
CRSR	CURSOR
CU	CUSHION
CUSH	CUSHION
DIR	DIRECTION
DUBB	DUBBING
FL	FRONT LOADING
FLY-WHL	FLYWHEEL
FR	FRONT
FUN	FUNCTION
G-CU	G-CUSHION
HDL	HANDOL
HIMERON	CLOTH
HINGE, BAT	HINGE, BATTERY
HLDR	HOLDER
HT-SINK	HEAT SINK
IB	INSTRUCTION BOOKLET
IDLE	IDLER
IND, L-R	INDICATOR, L-R
KEY, CONT	KEY, CONTROL
KEY, PRGM	KEY, PROGRAM
KNOB, SL	KNOB, SLIDE
LBL	LABEL
LID, BATT	LID, BATTERY
LID, CASS	LID, CASSETTE
LVR	LEVER
P-SP	P-SPRING
PANEL, CONT	PANEL, CONTROL
PANEL, FR	PANEL, FRONT
PRGM	PROGRAM
PULLY, LOAD MO	PULLY, LOAD MOTOR
RBN	RIBBON
S-	SPECIAL
SEG	SEGMENT
SH	SHEET
SHLD-SH	SHIELD-SHEET
SL	SLIDE
SP	SPRING
SP-SCREW	SPECIAL-SCREW
SPACER, BAT	SPACER, BATTERY
SPR	SPRING
SPR-P	P-SPRING
SPR-PC-PUSH	P-SPRING, C-PUSH
T-SP	T-SPRING
TERM	TERMINAL
TRIG	TRIGGER
TUN	TUNING
VOL	VOLUME
W	WASHER
WHL	WHEEL
WORM-WHL	WORM-WHEEL
ジグアーム	ARM, SHAFT
ジグガイド	GUIDE, SHAFT
ストラップ	STRAP
トクナベ	S-SCREW
ヒンジ	HINGE
ヒンジビス	S-SCREW
ビスセレート	SCREW, SERPART

サービス技術ニュース	
番号	連絡内容
G-	-
G-	-
G-	-

アイワ株式会社
AIWA CO., LTD.

9420208, 750038

Tokyo Japan