

aiwa

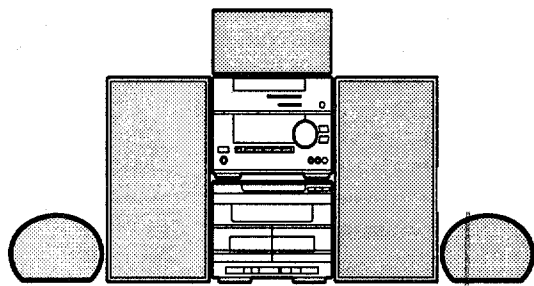

XR-AVH80



CD STEREO SYSTEM

- BASIC TAPE MECHANISM : 2ZM-3MK2 PR4NM
- BASIC CD MECHANISM : 4ZG-1 WRNM

- TYPE: EZ, K

SYSTEM	AMPLIFIER/ TUNER	CASSETTE DECK/ CD PLAYER	SPEAKER	REMOTE CONTROLLER
XR-AVH80 (TYPE: EZ)	RX-NAVH80	FD-NH80	SX-NAVH80 SX-C600 SX-R270	RC-T506
XR-AVH80 (TYPE: K)	RX-NAVH80	FD-NH80	SX-NAVH80 SX-C400 SX-R230	RC-T506

- If requiring information about the CD mechanism, see service manual of 4ZG-1WR.
(S/M Code No. 09-965-128-10T)

TABLE OF CONTENTS

SPECIFICATIONS	3
MODEL NO. RX-NAVH80	
ELECTRICAL MAIN PARTS LIST	4 ~ 7
CHIP RESISTOR PART CODE	8
TRANSISTOR ILLUSTRATION	8
BLOCK DIAGRAM	9 ~ 10
WIRING - 1 (MAIN)	11 ~ 12
SCHEMATIC DIAGRAM - 1 (MAIN)	13 ~ 15
SCHEMATIC DIAGRAM - 2 (FRONT)	16 ~ 18
WIRING - 2 (FRONT)	19 ~ 20
WIRING - 3 (MVR / R-AMP)	21 ~ 22
SCHEMATIC DIAGRAM - 3 (R-AMP)	23 ~ 24
WIRING - 4 (PT)	25
IC DESCRIPTION	26 ~ 30
PRACTICAL SERVICE FIGURE	30
ADJUSTMENT <TUNER >	31
FL GRID ASSIGNMENT & ANODE CONNECTION	32
IC BLOCK DIAGRAM	33 ~ 36
MECHANICAL EXPLODED VIEW 1 / 1	37 ~ 38
MECHANICAL PARTS LIST 1 / 1	39
MODEL NO. FD-NH80	
PROTECTION OF EYES FROM LASER BEAM DURING SERVICING	40
PRECAUTION TO REPLACE OPTICAL BLOCK	40
ELECTRICAL MAIN PARTS LIST	41 ~ 43
CHIP RESISTOR PART CODE	44
TRANSISTOR ILLUSTRATION	44
BLOCK DIAGRAM	45 ~ 46
WIRING - 1 (MAIN)	47 ~ 48
SCHEMATIC DIAGRAM - 1 (MAIN 1/2)	49 ~ 51
SCHEMATIC DIAGRAM - 2 (MAIN 2/2)	52 ~ 54
WIRING - 2 (KEY / LED / DECK)	55 ~ 56
FL GRID ASSIGNMENT & ANODE CONNECTION	57
IC DESCRIPTION	58 ~ 63
IC BLOCK DIAGRAM	64 ~ 66
TEST MODE	67
ADJUSTMENT <DECK/CD>	68 ~ 71
PRACTICAL SERVICE FIGURE	69
TAPE MECHANISM EXPLODED VIEW 1 / 1	72 ~ 73
TAPE MECHANISM PARTS LIST 1 / 1	74
MECHANICAL EXPLODED VIEW 1 / 1	75 ~ 76
MECHANICAL PARTS LIST 1 / 1	77
SPRING APPLICATION POSITION	78
SPEAKER DISASSEMBLY INSTRUCTIONS	79
SPEAKER PARTS LIST	80
ACCESSORIES / PACKAGE LIST	81
REFERENCE NAME LIST	82

SPECIFICATIONS

STEREO RECEIVER RX-NAVH80

<FM tuner section>

Tuning range 87.5 MHz to 108 MHz
Usable sensitivity (IHF) 16.8 dBf
Antenna terminals 75 ohms (unbalanced)

<MW Tuner section>

Tuning range 531 kHz to 1602 kHz (9 kHz step)
 530 kHz to 1710 kHz (10 kHz step)
Usable sensitivity 350 μ V/m
Antenna Loop antenna

<LW Tuner section>

Tuning range 144 kHz to 290 kHz
Usable sensitivity 1400 μ V/m
Antenna Loop antenna

<Amplifier section>

Power output **Front** (without connecting to the SURROUND SPEAKERS)
 Rated: 80 W + 80 W (6 ohms, T.H.D. 1 %, 1 kHz/DIN 45500)
 Reference: 100 W + 100 W (6 ohms, T.H.D. 10 %, 1 kHz/DIN 45324)
 DIN MUSIC POWER: 180 W + 180 W <EZ ONLY>
Rear (Surround)
 Rated: 10 W + 10 W (16 ohms, T.H.D. 1 %, 1 kHz/DIN 45500)
 Reference: 12.5 W + 12.5 W (16 ohms, T.H.D. 10 %, 1 kHz/DIN 45324)
 DIN MUSIC POWER: 30 W + 30 W <EZ ONLY>
Center
 Rated: 20 W (8 ohms, T.H.D. 1 %, 1 kHz/DIN 45500)
 Reference: 25 W (8 ohms, T.H.D. 10 %, 1 kHz/DIN 45324)
 DIN MUSIC POWER: 60 W <EZ ONLY>
Total harmonic distortion 0.1 % (60 W, 1 kHz, 6 ohms, DIN AUDIO)
Inputs VIDEO 1/MD IN: 200 mV (adjustable)
 VIDEO 2/AUX IN: 200 mV (adjustable)
Outputs MIC 1, MIC 2: 1 mV (10 kohms)
 REC OUT: 200 mV
 SUPER WOOFER: 2.6 V
 SPEAKERS: accept speakers of 6 ohms or more
 SURROUND SPEAKERS: accept speakers of 16 ohms or more
 CENTER SPEAKERS: accept speakers of 8 ohms or more
 PHONES (stereo jack): accepts headphones of 32 ohms or more

<General>

Power requirements 230 V AC, 50 Hz
Power consumption 160 W (System 180 W)
Dimensions of main unit (W x H x D) 260 x 199 x 333 mm
Weight of main unit 7.3 kg <EZ>
 6.4 kg <K>

COMPACT DISC/STEREO CASSETTE DECK FD-NH80

<Cassette deck section>

Track format 4 tracks, 2 channels stereo
Frequency response Metal tape: 50 Hz – 17000 Hz
 CrO₂ tape: 50 Hz – 16000 Hz
 Normal tape: 50 Hz – 15000 Hz
Signal-to-noise ratio 75 dB (Dolby B NR ON, Metal tape peak level)
Recording system AC bias
Heads Deck 1: Playhead x 1
 Deck 2: Recording/playback/erase head x 1

<Compact disc player section>

Laser Semiconductor laser ($\lambda = 780$ nm)
D-A converter 1 bit dual
Signal-to-noise ratio 85 dB (1 kHz, 0 dB)
Harmonic distortion 0.03% (1 kHz, 0 dB)
Wow and flutter Unmeasurable

<General>

Dimensions (W x H x D) 260 X 204 X 320.2 mm
Weight 4 kg

SPEAKER SYSTEM SX-NAVH80

Cabinet type 3 way, bass reflex (magnetic shielded type) <EZ>
 3 way, bass reflex (magnetic sealed type) <K>
Speakers Woofer:
 160 mm cone type
 Tweeter:
 60 mm cone type
 Super tweeter:
 20 mm ceramic type
Impedance 6 ohms
Output sound pressure level 88 dB/W/m
Dimensions (W x H x D) 250 x 396 x 250 mm
Weight 5 kg

- Design and specifications are subject to change without notice.
- Manufactured under license from Dolby Laboratories Licensing Corporation.
 "DOLBY", the double-D symbol  and "PRO LOGIC" are trademarks of Dolby Laboratories Licensing Corporation.
- The word "BBE" and the "BBE symbol" are trademarks of BBE Sound, Inc.
 Under license from BBE Sound, Inc.

MODEL NO.

RX-NAVH80

ELECTRICAL MAIN PARTS LIST

If can't understand for Description please kindly refer to "REFERENCE NAME LIST".

REF. NO.	PART NO.	KANRI NO.	DESCRIPTION	REF. NO.	PART NO.	KANRI NO.	DESCRIPTION				
IC											
	87-NT1-619-010		IC, LC866440W-5E65		87-A40-274-010		DIODE, FMB-G16L				
	87-A20-650-010		IC, RPM6938-V11		87-A40-202-080		ZENER, UZ5.1BSB				
	87-017-915-080		IC, BU4094BCF		87-017-481-080		ZENER, UZ5.6BSB				
	87-A20-056-010		IC, BA3880S		87-A40-186-080		ZENER, UZ5.1BSB				
	87-A20-107-010		IC, BA3836		87-A40-235-080		ZENER, MTZJ9.1C				
	87-A20-083-010		IC, BA3835S		87-020-339-080		C-DIODE, ISS226				
	87-017-804-010		IC, BU4052BCP	MAIN C.B							
	87-017-888-080		IC, NJM4558MD								
	87-017-914-010		IC, BU4094 BCP								
	87-A20-069-040		C-IC, BA3842F								
	87-070-127-110		IC, LC72131 D								
	87-017-714-110		IC, LA1836								
	87-A20-514-010		C-IC, M62460AFP								
	87-A20-440-040		C-IC, BU1920FS<EZ>								
								C101	87-016-520-090		CAP, E 3300-65
								C102	87-016-520-090		CAP, E 3300-65
								C104	87-010-235-080		CAP, E 470-16 SME
								C105	87-010-235-080		CAP, E 470-16 SME
				C106	87-016-285-080		CAP, E 47-100SME				
				C107	87-010-407-080		CAP, ELECT 33-50V				
				C108	87-010-407-080		CAP, ELECT 33-50V				
				C109	87-010-263-080		CAP, ELECT 100-10V				
				C112	87-010-382-080		CAP, ELECT 22-25V				
				C113	87-010-403-080		CAP, ELECT 3.3-50V				
TRANSISTOR											
	87-A30-086-070		C-TR, CSD1306E								
	89-213-702-010		TR, 2SB1370 (1.8W)								
	89-109-352-080		TR, 2SA935Q	C116	87-012-140-080		CAP 470P				
	87-026-610-080		TR, KTC3198GR	C121	87-012-368-080		C-CAP, S 0.1-50 F				
	87-A30-083-080		TR, CSD1489B	C122	87-012-368-080		C-CAP, S 0.1-50 F				
	87-A30-076-080		C-TR, 2SC3052F	C123	87-012-368-080		C-CAP, S 0.1-50 F				
	87-A30-075-080		C-TR, 2SA1235F	C124	87-012-368-080		C-CAP, S 0.1-50 F				
	89-324-122-080		TR, 2SC2412K	C125	87-010-264-040		CAP, E 100-10 5L				
	87-A30-111-080		TR, C2N5401	C126	87-010-189-010		CAP, CHIP S 8200P				
	87-A30-097-010		TR, FN 1016	C127	87-010-189-010		CAP, CHIP S 8200P				
	87-A30-098-010		TR, FP 1016	C152	87-010-260-080		CAP, ELECT 47-25V				
	87-A30-089-010		FET, 2SK2723	C163	87-018-212-080		CAP, TC U 0.022-50 ZF SA				
	87-026-226-080		CHIP-TR, DTA143EK	C164	87-018-212-080		CAP, TC U 0.022-50 ZF SA				
	89-110-372-080		TR, 2SA1037K(R)	C165	87-010-197-080		CAP, CHIP 0.01 DM				
	87-026-211-080		TR, DTA144EK	C166	87-010-197-080		CAP, CHIP 0.01 DM				
	87-026-230-080		CHIP-TR, DTA114YK	C171	87-016-658-090		CAP, E 4700-35 SMG				
	87-026-227-080		C-TR, DTA114EK	C172	87-016-658-090		CAP, E 4700-35 SMG				
	87-026-235-080		CHIP-TR, DTC114EK	C173	87-012-368-080		C-CAP, S 0.1-50 F				
	87-026-229-080		TR, DTA143XK	C174	87-012-368-080		C-CAP, S 0.1-50 F				
	89-112-965-080		TR, 2SA1296 (0.75W)	C175	87-012-368-080		C-CAP, S 0.1-50 F				
	87-026-228-080		TR, DTA124EK	C176	87-012-368-080		C-CAP, S 0.1-50 F				
	89-109-521-080		TR, 2SA952 (0.6W)	C201	87-010-402-080		CAP, ELECT 2.2-50V				
	87-A30-047-080		TR, CSD655E	C202	87-010-402-080		CAP, ELECT 2.2-50V				
	87-A30-087-080		C-FET, 2SK2158	C205	87-010-184-080		C-CAP, S 3300P-50 B				
	87-026-214-080		TR, DTA114YS (0.3W)	C206	87-010-184-080		C-CAP, S 3300P-50 B				
	89-327-143-080		TR, 2SC2714 (0.1W)	C207	87-010-404-080		CAP, ELECT 4.7-50V				
	87-A30-112-080		TR, C2N5551	C208	87-010-404-080		CAP, ELECT 4.7-50V				
	89-420-612-010		TR, 2SD2061 (2W)	C209	87-010-497-040		CAP, E 4.7-35 GAS				
	89-505-434-540		C-FET, 2SK543(4/5)	C210	87-010-497-040		CAP, E 4.7-35 GAS				
	87-026-269-080		TR, DTA114ES	C211	87-010-184-080		CHIP CAPACITOR 3300P(K)				
	87-026-213-080		C-TR, DTC114YK	C212	87-010-184-080		CHIP CAPACITOR 3300P(K)				
				C213	87-010-260-080		CAP, ELECT 47-25V				
DIODE											
	87-A40-116-060		DIODE, RS403L-B-D-51	C214	87-010-260-080		CAP, ELECT 47-25V				
	87-A40-115-060		DIODE, RS603M	C215	87-010-196-080		CHIP CAPACITOR, 0.1-25				
	87-070-274-080		DIODE, 1N4003 SEM	C217	87-010-246-080		CAP, ELECT 47-35V				
	87-A40-270-080		C-DIODE, MC2838	C225	87-A10-516-080		C-CAP, S 100P-200 CH				
	87-A40-269-080		C-DIODE, MC2836	C226	87-A10-516-080		C-CAP, S 100P-200 CH				
	87-020-027-080		CHIP-DIODE ISS184	C229	87-016-461-080		C-CAP, S 0.47-16 Z F				
	87-A40-206-080		ZENER, UZ10BSC	C230	87-016-461-080		C-CAP, S 0.47-16 Z F				
	87-A40-210-080		ZENER, UZ30BSD	C233	87-010-196-080		CHIP CAPACITOR, 0.1-25				
	87-070-345-080		DIODE, 1N4148	C234	87-010-196-080		CHIP CAPACITOR, 0.1-25				
	87-A40-205-080		ZENER, UZ6.2BSC	C235	87-010-196-080		CHIP CAPACITOR, 0.1-25				
	87-017-436-080		ZENER, UZ4.7BSA	C236	87-010-196-080		CHIP CAPACITOR, 0.1-25				
	87-017-437-080		DIODE, 1N4148M	C401	87-010-184-080		CHIP CAPACITOR 3300P(K)				
				C402	87-010-184-080		CHIP CAPACITOR 3300P(K)				
				C403	87-010-405-080		CAP, ELECT 10-50V				

REF. NO.	PART NO.	KANRI NO.	DESCRIPTION	REF. NO.	PART NO.	KANRI NO.	DESCRIPTION
C404	87-010-405-080		CAP, ELECT 10-50V	C782	87-010-405-080		CAP, ELECT 10-50V
C405	87-010-260-080		CAP, ELECT 47-25V	C787	87-010-184-080		CHIP CAPACITOR 3300P(K)
C406	87-010-101-080		CAP, ELECT 220-16	C788	87-010-184-080		CHIP CAPACITOR 3300P(K)
C407	87-010-188-080		CAP,CHIP 6800P	C789	87-010-179-080		CAP,CHIP S B1200P
C408	87-010-188-080		CAP,CHIP 6800P	C790	87-010-179-080		CAP,CHIP S B1200P
C409	87-018-127-080		CAP, CER 470P-50V	C791	87-010-401-080		CAP, ELECT 1-50V
C410	87-018-127-080		CAP, CER 470P-50V	C792	87-010-182-080		C-CAP,S 2200P-50 K B
C411	87-010-197-080		CAP, CHIP 0.01 DM	C793	87-010-189-080		C-CAP,S 8200P-50 B
C412	87-010-197-080		CAP, CHIP 0.01 DM	C794	87-010-408-080		CAP, ELECT 47-50V
C413	87-010-195-080		C-CAP,S 0.068-25 F	C795	87-010-194-080		CAP, CHIP 0.047
C414	87-010-195-080		C-CAP,S 0.068-25 F	C796	87-010-403-080		CAP, ELECT 3.3-50V
C415	87-010-404-080		CAP, ELECT 4.7-50V	C801	87-018-134-080		CAPACITOR,TC-U 0.01-16
C416	87-010-404-080		CAP, ELECT 4.7-50V	C806	87-018-134-080		CAPACITOR,TC-U 0.01-16
C417	87-010-404-080		CAP, ELECT 4.7-50V	C814	87-010-197-080		CAP, CHIP 0.01 DM
C418	87-010-404-080		CAP, ELECT 4.7-50V	C815	87-018-134-080		CAPACITOR,TC-U 0.01-16
C419	87-010-544-080		CAP, ELECT 0.1-50V	C816	87-018-134-080		CAPACITOR,TC-U 0.01-16
C500	87-010-197-080		CAP, CHIP 0.01 DM	C817	87-010-197-080		CAP, CHIP 0.01 DM
C501	87-010-183-080		C-CAP,S 2700P-50 B	C818	87-010-197-080		CAP, CHIP 0.01 DM
C502	87-010-194-080		CAP, CHIP 0.047	C819	87-010-197-080		CAP, CHIP 0.01 DM
C503	87-010-196-080		CHIP CAPACITOR,0.1-25	C820	87-010-408-080		CAP, ELECT 47-50V
C504	87-010-263-080		CAP, ELECT 100-10V	C821	87-010-197-080		CAP, CHIP 0.01 DM
C505	87-010-404-080		CAP, ELECT 4.7-50V	C822	87-010-197-080		CAP, CHIP 0.01 DM
C506	87-010-404-080		CAP, ELECT 4.7-50V	C823	87-010-197-080		CAP, CHIP 0.01 DM
C507	87-010-545-080		CAP, ELECT 0.22-50V	C828	87-010-196-080		CHIP CAPACITOR,0.1-25
C509	87-010-194-080		CAP, CHIP 0.047	C829	87-010-196-080		CHIP CAPACITOR,0.1-25
C510	87-010-384-080		CAP, ELECT 100-25V	C860	87-010-405-080		CAP,E 10-50V<EZ>
C511	87-010-404-080		CAP, ELECT 4.7-50V	C861	87-010-196-080		CHIP CAPACITOR,0.1-25<EZ>
C512	87-010-404-080		CAP, ELECT 4.7-50V	C862	87-012-156-080		C-CAP,S 220P-50 J CH GRM<EZ>
C542	87-018-209-080		CAP,TC-U 0.1-50 Z F	C863	87-018-123-080		CAP,TC U 220P-50 K B UP050<EZ>
C600	87-010-405-080		CAP, ELECT 10-50V	C864	87-010-315-080		C-CAP,S 27P-50 J CH<EZ>
C601	87-010-213-080		C-CAP,S 0.015-50 B	C865	87-010-315-080		C-CAP,S 27P-50 J CH<EZ>
C602	87-010-213-080		C-CAP,S 0.015-50 B	C866	87-010-196-080		CHIP CAPACITOR,0.1-25<EZ>
C605	87-010-544-080		CAP, ELECT 0.1-50V	C867	87-018-127-080		CAP,TC U 470P-50 K B UP050<EZ>
C606	87-010-544-080		CAP, ELECT 0.1-50V	C868	87-010-405-080		CAP,E 10-50V<EZ>
C607	87-010-196-080		CHIP CAPACITOR,0.1-25	C869	87-010-197-080		CAP, CHIP 0.01 DM<EZ>
C608	87-010-196-080		CHIP CAPACITOR,0.1-25	C872	87-010-196-080		CHIP CAPACITOR,0.1-25<EZ>
C620	87-010-318-080		C-CAP,S 47P-50 CH	C940	87-010-197-080		CAP, CHIP 0.01 DM
C621	87-010-318-080		C-CAP,S 47P-50 CH	C942	87-010-150-080		C-CAP,S 6P-50 D CH
C622	87-010-318-080		C-CAP,S 47P-50 CH	C946	87-010-401-080		CAP, ELECT 1-50V
C633	87-012-142-080		CAP, S 0.33-16	C949	87-014-049-080		CAP,PP 470P-100 J
C634	87-010-196-080		CHIP CAPACITOR,0.1-25	C952	87-010-197-080		CAP, CHIP 0.01 DM
C635	87-018-209-080		CAP, CER 0.1-50V	C957	87-010-315-080		C-CAP,S 27P-50 J CH
C636	87-010-196-080		CHIP CAPACITOR,0.1-25	C958	87-010-197-080		CAP, CHIP 0.01 DM
C701	87-010-381-080		CAP, ELECT 330-16V	C960	87-010-196-080		CHIP CAPACITOR,0.1-25
C702	87-010-404-080		CAP, ELECT 4.7-50V	CF801	87-008-423-080		FILTER, SFE10.7MS3GH-A-TP21
C703	87-010-197-080		CAP, CHIP 0.01 DM	CF802	82-785-747-080		CF,MS2 GHY R
C704	87-010-197-080		CAP, CHIP 0.01 DM	FB143	87-008-372-080		FILTER, EMI BL OIRNI
C711	87-010-263-080		CAP, ELECT 100-10V	FFE801	A8-62A-191-030		62A-1 FEENM
C712	87-010-196-080		CHIP CAPACITOR,0.1-25	J252	87-A60-031-010		JACK,6.3 BLK ST W/S
C715	87-010-197-080		CAP, CHIP 0.01 DM	J253	87-099-801-010		JACK,PIN 1P BLK
C716	87-010-197-080		CAP, CHIP 0.01 DM	J254	87-033-240-010		TERMINAL,4P HSP-324V1-05
C722	87-010-152-080		C-CAP,S 8P-50 CH	J801	87-033-241-010		TERMINAL,ANT 2P AJ-2039
C723	87-010-178-080		CHIP CAP 1000P	L201	87-003-383-010		COIL,1UH-S
C725	87-010-178-080		CHIP CAP 1000P	L202	87-003-383-010		COIL,1UH-S
C727	87-010-196-080		CHIP CAPACITOR,0.1-25	L202	87-003-383-010		COIL,1UH-S
C728	87-010-248-080		CAP, ELECT 220-10V	L701	87-003-293-010		COIL, TRAP MPX
C760	87-010-197-080		CAP, CHIP 0.01 DM	L702	87-003-293-010		COIL, TRAP MPX
C761	87-010-196-080		CHIP CAPACITOR,0.1-25	L741	87-A50-015-010		COIL,FM DET(TOK)
C770	87-010-405-080		CAP, ELECT 10-50V	L742	87-A90-051-010		FLFR,CF4Z-450(TOK)
C771	87-010-405-080		CAP, ELECT 10-50V	L770	87-003-143-080		COIL 4.7 UH
C772	87-010-194-080		CAP, CHIP 0.047	L832	87-003-098-080		COIL,2.2UH
C773	87-010-196-080		CHIP CAPACITOR,0.1-25	L850	87-003-098-080		COIL,2.2UH<EZ>
C774	87-010-248-080		CAP, ELECT 220-10V	L941	87-A50-020-010		COIL,ANT LW (COI) 252kHz
C775	87-010-405-080		CAP, ELECT 10-50V	L942	87-A50-019-010		COIL,OSC LW (COI) 856kHz
C776	87-010-197-080		CAP, CHIP 0.01 DM	L981	86-NF4-665-010		AM PACK 1(TOK)
C777	87-010-400-080		CAP, ELECT 0.47-50V	LED321	87-070-281-080		LED,SLZ736A-25-S-T1
C778	87-010-401-080		CAP, ELECT 1-50V	LED322	87-070-281-080		LED,SLZ736A-25-S-T1
C779	87-010-401-080		CAP, ELECT 1-50V	LED323	87-070-281-080		LED,SLZ736A-25-S-T1
C780	87-010-197-080		CAP, CHIP 0.01 DM	LED324	87-070-281-080		LED,SLZ736A-25-S-T1
C781	87-010-405-080		CAP, ELECT 10-50V	LED325	87-070-281-080		LED,SLZ736A-25-S-T1

REF. NO.	PART NO.	KANRI NO.	DESCRIPTION	REF. NO.	PART NO.	KANRI NO.	DESCRIPTION
LED331	87-070-281-080		LED,SLZ736A-25-S-T1	C708	87-010-993-080		C-CAP,S 0.056-25 B
LED332	87-070-281-080		LED,SLZ736A-25-S-T1	C709	87-012-393-080		C-CAP,S 0.22-16 R K
LED333	87-070-281-080		LED,SLZ736A-25-S-T1	C710	87-012-393-080		C-CAP,S 0.22-16 R K
LED334	87-070-281-080		LED,SLZ736A-25-S-T1	C711	87-010-401-040		CAP,E 1-50 SME
LED335	87-070-281-080		LED,SLZ736A-25-S-T1	C712	87-010-553-040		CAP,E 47-16 GAS
△ PR201	87-A90-195-080		PROTECTOR 7A 125V 251	C713	87-010-405-040		CAP,E 10-50
△ PR202	87-A90-195-080		PROTECTOR 7A 125V 251	C714	87-010-552-040		CAP,E 22-16 GAS
R117	87-022-394-080		RES,NF 0.47-1/4WJ	C715	87-016-669-080		C-CAP,S 0.1-25 K B
R229	87-A00-258-080		RES,M/F 0.22-1W J	C716	87-010-196-080		CHIP CAPACITOR,0.1-25
R230	87-A00-258-080		RES,M/F 0.22-1W J	FB101	87-008-372-080		FLTR,EMIB01 RN1
R231	87-A00-258-080		RES,M/F 0.22-1W J	FB102	87-008-372-080		FLTR,EMIB01 RN1
R232	87-A00-258-080		RES,M/F 0.22-1W J	FL201	86-NT1-636-010		FL,BJ451GK
RY101	87-A90-464-010		RELAY, DGL2D2-O(M)	J601	87-A60-284-010		JACK,3.5MO (MSC)
SFR722	87-024-432-080		SFR,4.7K RH063EC	J602	87-A60-284-010		JACK,3.5MO (MSC)
TC701	87-011-221-080		CAP,TRIMMER 30P	L202	87-005-151-080		COIL,2.2UH U LAL03
TC942	87-011-221-080		CAP,TRIMMER 30P	L220	87-A50-052-010		COIL,CLOCK 5.76MHZ T1
TH201	87-A90-221-010		C-THMS,100K	L221	87-003-152-080		COIL, 100UH
TH202	87-A90-221-010		C-THMS,100K	LED301	87-A40-316-080		LED,SLR-56PCT31 GRN
W101	85-NF5-628-010		F-CABLE 7P-2.5	LED302	87-A40-316-080		LED,SLR-56PCT31 GRN
W101	85-NF5-628-010		F-CABLE 7P-2.5	LED303	87-A40-316-080		LED,SLR-56PCT31 GRN
W304	87-NT1-650-010		CORD,FG15P	LED304	87-A40-316-080		LED,SLR-56PCT31 GRN
X703	84-508-618-010		VIBRATER CSB456 F15	LED305	87-A40-316-080		LED,SLR-56PCT31 GRN
X721	87-030-372-010		VIB,XTAL 7.2MHZ	LED306	87-A40-316-080		LED,SLR-56PCT31 GRN
X850	89-KT1-608-010		X,TAL 4.332MHZ<EZ>	LED307	87-A40-316-080		LED,SLR-56PCT31 GRN
				LED308	87-A40-316-080		LED,SLR-56PCT31 GRN
FRONT C.B				LED309	87-A40-316-080		LED,SLR-56PCT31 GRN
C201	87-010-555-040		CAP,E 100-10 GAS	LED310	87-A40-316-080		LED,SLR-56PCT31 GRN
C202	87-010-497-040		CAP,E 4.7-35 GAS	LED311	87-A40-317-080		LED,SLR-342VCT31 RED
C203	87-010-494-040		CAP,E 1-50 GAS	LED312	87-A40-317-080		LED,SLR-342VCT31 RED
C204	87-A10-189-040		CAP,E 220-10	LED313	87-A40-317-080		LED,SLR-342VCT31 RED
C205	87-010-196-080		CHIP CAPACITOR,0.1-25	LED314	87-A40-317-080		LED,SLR-342VCT31 RED
C206	87-010-196-080		CHIP CAPACITOR,0.1-25	LED315	87-A40-317-080		LED,SLR-342VCT31 RED
C215	87-010-560-040		CAP,E 10-50 GAS	LED321	87-070-281-080		LED,SLZ736A-25-S-T1
C216	87-010-560-040		CAP,E 10-50 GAS	LED322	87-070-281-080		LED,SLZ736A-25-S-T1
C217	87-010-408-040		CAP,E 47-50 SME	LED331	87-070-281-080		LED,SLZ736A-25-S-T1
C221	87-010-312-080		C-CAP,S 15P-50 CH	LED332	87-070-281-080		LED,SLZ736A-25-S-T1
C222	87-010-180-080		C-CER 1500P	LED333	87-070-281-080		LED,SLZ736A-25-S-T1
C223	87-010-498-040		CAP,E 10-16 GAS	LED334	87-070-281-080		LED,SLZ736A-25-S-T1
C224	87-012-145-080		CAP,CHIP S 270P CH	LED336	87-A40-363-080		LED,SLH-56PCTB7 GRN
C225	87-010-560-040		CAP,E 10-50 GAS	LED337	87-A40-363-080		LED,SLH-56PCTB7 GRN
C301	87-010-196-080		CHIP CAPACITOR,0.1-25	LED338	87-A40-268-080		LED,SLH-56DCT31 ORN
C302	87-018-209-080		CAP, CER 0.1-50V	LED339	87-A40-268-080		LED,SLH-56DCT31 ORN
C350	87-010-112-040		CAP,E 100-16	LED340	87-A40-268-080		LED,SLH-56DCT31 ORN
C501	87-010-322-080		C-CAP,S 100P-50 CH	LED341	87-A40-268-080		LED,SLH-56DCT31 ORN
C502	87-010-196-080		CHIP CAPACITOR,0.1-25	LED342	87-A40-268-080		LED,SLH-56DCT31 ORN
C503	87-010-196-080		CHIP CAPACITOR,0.1-25	LED343	87-A40-268-080		LED,SLH-56DCT31 ORN
C504	87-010-196-080		CHIP CAPACITOR,0.1-25	S120	87-A90-095-080		SW,TACT EVQ11G04M
C505	87-010-196-080		CHIP CAPACITOR,0.1-25	S121	87-A90-095-080		SW,TACT EVQ11G04M
C506	87-010-196-080		CHIP CAPACITOR,0.1-25	S122	87-A90-095-080		SW,TACT EVQ11G04M
C601	87-010-196-080		CHIP CAPACITOR,0.1-25	S123	87-A90-095-080		SW,TACT EVQ11G04M
C602	87-010-545-040		CAP,E 0.22-50 SME	S124	87-A90-095-080		SW,TACT EVQ11G04M
C603	87-010-321-080		CHIP CAPACITOR,82P(J)	S125	87-A90-095-080		SW,TACT EVQ11G04M
C604	87-010-196-080		CHIP CAPACITOR,0.1-25	S126	87-A90-095-080		SW,TACT EVQ11G04M
C605	87-010-196-080		CHIP CAPACITOR,0.1-25	S127	87-A90-095-080		SW,TACT EVQ11G04M
C608	87-010-177-080		C-CAP,S 820P-50 SL	S128	87-A90-095-080		SW,TACT EVQ11G04M
C609	87-016-251-040		CAP,E 220-16 SMG	S129	87-A90-095-080		SW,TACT EVQ11G04M
C610	87-010-405-040		CAP,E 10-50	S130	87-A90-095-080		SW,TACT EVQ11G04M
C611	87-010-560-040		CAP,E 10-50 GAS	S131	87-A90-095-080		SW,TACT EVQ11G04M
C612	87-010-406-040		CAP,E 22-50 SME	S132	87-A90-095-080		SW,TACT EVQ11G04M<EZ>
C613	87-010-494-040		CAP,E 1-50 GAS	S133	87-A90-095-080		SW,TACT EVQ11G04M<EZ>
C615	87-010-186-080		CAP,CHIP 4700P	S134	87-A90-095-080		SW,TACT EVQ11G04M<EZ>
C618	87-010-196-080		CHIP CAPACITOR,0.1-25	S135	87-A90-095-080		SW,TACT EVQ11G04M
C701	87-010-401-040		CAP,E 1-50 SME	S136	87-A90-095-080		SW,TACT EVQ11G04M
C702	87-010-494-040		CAP,E 1-50 GAS	S137	87-A90-095-080		SW,TACT EVQ11G04M
C703	87-010-182-080		C-CAP,S 2200P-50 B	S140	87-A90-095-080		SW,TACT EVQ11G04M
C704	87-010-182-080		C-CAP,S 2200P-50 B	S141	87-A90-095-080		SW,TACT EVQ11G04M
C705	87-010-545-040		CAP,E 0.22-50 SME	S142	87-A90-095-080		SW,TACT EVQ11G04M
C706	87-010-545-040		CAP,E 0.22-50 SME	VR601	87-A90-124-010		VR,RTRY 10KA L20
C707	87-010-993-080		C-CAP,S 0.056-25 B	VR701	86-NT1-634-010		VR,RTRY 100KW-L20

REF. NO.	PART NO.	KANRI NO.	DESCRIPTION	REF. NO.	PART NO.	KANRI NO.	DESCRIPTION
MVR C.B				C911	87-012-140-080		CAP 470P
C616	87-010-545-040		CAP,E 0.22-50 SME	C912	87-010-196-080		CHIP CAPACITOR,0.1-25
C617	87-010-545-040		CAP,E 0.22-50 SME	C913	87-012-141-080		C-CAP,S 0.022-16 ZF
C637	87-010-405-040		CAP,E 10-50	C920	87-010-402-040		CAP,E 2.2-50 SME
C638	87-010-405-040		CAP,E 10-50	C921	87-010-180-080		C-CER 1500P
C751	87-010-402-040		CAP,E 2.2-50 SME	C922	87-010-406-040		CAP,E 22-50 SME
C752	87-010-402-040		CAP,E 2.2-50 SME	C923	87-012-140-080		CAP 470P
C753	87-010-404-040		CAP,E 4.7-50 SME	C924	87-010-260-040		CAP,E 47-25 SME
C754	87-010-404-040		CAP,E 4.7-50 SME	C925	87-010-993-080		C-CAP,S 0.056-25 B
C755	87-010-260-040		CAP,E 47-25 SME	C926	87-010-196-080		CHIP CAPACITOR,0.1-25
C756	87-010-196-080		CHIP CAPACITOR,0.1-25	C927	87-010-197-080		CAP, CHIP 0.01 DM
C757	87-010-384-040		CAP,E 100-25 SME	C928	87-010-196-080		CHIP CAPACITOR,0.1-25
C803	87-010-405-040		CAP,E 10-50	C934	87-010-154-080		CAP CHIP 10P
C804	87-010-405-040		CAP,E 10-50	C943	87-012-140-080		CAP 470P
C805	87-010-260-040		CAP,E 47-25 SME	C949	87-010-154-080		CAP CHIP 10P
C806	87-016-081-080		C-CAP,S 0.1-16 RK	C950	87-010-180-080		C-CER 1500P
C807	87-010-401-040		CAP,E 1-50 SME	C951	87-010-402-040		CAP,E 2.2-50 SME
C808	87-010-318-080		C-CAP,S 47P-50 CH	C952	87-010-260-040		CAP,E 47-25 SME
C809	87-010-318-080		C-CAP,S 47P-50 CH	C954	87-010-406-040		CAP,E 22-50 SME
C810	87-012-368-080		C-CAP,S 0.1-50 F	C956	87-010-993-080		C-CAP,S 0.056-25 B
C811	87-010-263-040		CAP,E 100-10	C957	87-010-196-080		CHIP CAPACITOR,0.1-25
C812	87-010-406-040		CAP,E 22-50 SME	C958	87-010-197-080		CAP, CHIP 0.01 DM
C822	87-016-081-080		C-CAP,S 0.1-16 RK	C959	87-010-196-080		CHIP CAPACITOR,0.1-25
C823	87-016-081-080		C-CAP,S 0.1-16 RK	C960	87-010-387-040		CAP,E 470-25 M SME
C824	87-016-081-080		C-CAP,S 0.1-16 RK	C963	87-010-194-080		CAP, CHIP 0.047
C825	87-012-140-080		CAP 470P	J901	87-A60-351-010		JACK,PIN 3P O/W/R HSP-253V17
C827	87-010-401-040		CAP,E 1-50 SME	L901	87-003-383-010		COIL,1UH-S
C828	87-010-177-080		C-CAP,S 820P-50 SL	L903	87-003-383-010		COIL,1UH-S
C831	87-A10-229-080		C-CAP,S 0.68-10 K W5	R942	87-022-663-080		RES,M/F 0.1-1W J
C832	87-012-393-080		C-CAP,S 0.22-16 R K	R988	87-022-663-080		RES,M/F 0.1-1W J
C833	87-012-393-080		C-CAP,S 0.22-16 R K				
C834	87-010-404-040		CAP,E 4.7-50 SME	AC2 C.B			
C835	87-010-404-040		CAP,E 4.7-50 SME	△ PRI01	87-026-682-080		PROTECTOR,10A 60V491
C836	87-012-393-080		C-CAP,S 0.22-16 R K	△ PRI02	87-026-682-080		PROTECTOR,10A 60V491
C837	87-012-393-080		C-CAP,S 0.22-16 R K	△ PRI03	87-026-681-080		PROTECTOR,5A 60V 491
C838	87-016-081-080		C-CAP,S 0.1-16 RK	△ PRI04	87-026-681-080		PROTECTOR,5A 60V 491
C841	87-016-081-080		C-CAP,S 0.1-16 RK	△ PRI05	87-026-682-080		PROTECTOR,10A 60V491
C842	87-016-081-080		C-CAP,S 0.1-16 RK	△ PRI06	87-026-682-080		PROTECTOR,10A 60V491
C845	87-016-081-080		C-CAP,S 0.1-16 RK				
C847	87-010-176-080		C-CAP,S 680P-50 SL	AC1 C.B			
C849	87-010-176-080		C-CAP,S 680P-50 SL	△ F101	87-035-191-010		FUSE,3.15A 250V T218
C852	87-016-456-040		CAP,E 22-16 LLA	△ FC1	87-033-213-080		CLAMP, FUSE
C853	87-016-251-040		CAP,E 220-16 SMG	△ FC2	87-033-213-080		CLAMP, FUSE
C854	87-016-471-040		CAP,E 10-50 K SME	△ PT103	86-NT2-628-010		PT,6NT2 PR-E
C856	87-010-384-040		CAP,E 100-25 SME	△ T1	87-A60-317-010		TERMINAL, 1P MSC
C857	87-012-368-080		C-CAP,S 0.1-50 F	△ T2	87-A60-317-010		TERMINAL, 1P MSC
C861	87-010-400-040		CAP,E 0.47-50				
C862	87-010-400-040		CAP,E 0.47-50				
C863	87-010-400-040		CAP,E 0.47-50				
C864	87-010-400-040		CAP,E 0.47-50				
C865	87-012-368-080		C-CAP,S 0.1-50 F				
C866	87-010-322-080		C-CAP,S 100P-50 CH				
C867	87-010-322-080		C-CAP,S 100P-50 CH				
C868	87-010-322-080		C-CAP,S 100P-50 CH				
C871	87-010-182-080		C-CAP,S 2200P-50 K B				
C872	87-018-208-080		CAP 0.047-50F				
L801	87-005-481-080		COIL,47UH J FLR50				
R827	87-025-407-080		RES,100K-1/8W				
VR751	86-NT1-632-010		VR,50K BX4-L20				
R-AMP C.B							
C901	87-012-368-080		C-CAP,S 0.1-50 F				
C902	87-012-368-080		C-CAP,S 0.1-50 F				
C903	87-010-398-090		CAP,E 2200-35V				
C904	87-010-398-090		CAP,E 2200-35V				
C906	87-012-140-080		CAP 470P				
C908	87-010-246-040		CAP,E 47-35 SME				
C909	87-012-140-080		CAP 470P				

○ チップ抵抗部品コード / CHIP RESISTOR PART CODE

チップ抵抗部品コードの成り立ち
Chip Resistor Part Coding

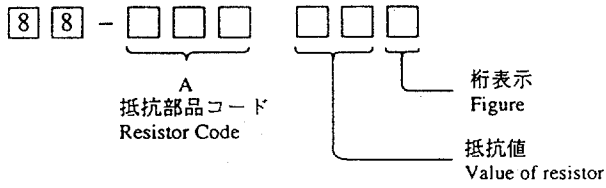

チップ抵抗
Chip resistor

容量 Wattage	種類 Type	許容誤差 Tolerance	記号 Symbol	寸法 / Dimensions (mm)			抵抗コード : A Resistor Code: A	
				外形 / Form	L	W		t
1/16W	1608	±5%	CJ		1.6	0.8	0.45	108
1/10W	2125	±5%	CJ		2	1.25	0.45	118
1/8W	3216	±5%	CJ		3.2	1.6	0.55	128

TRANSISTOR ILLUSTRATION



E C B

2SA1296GR
KTC3198GR



E C B

CSD1489B
2SA952
CSD655E
C2N5551



E B C

C2N5401

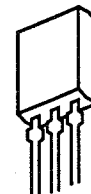

E C B

2SA935Q



B C E

2SB1370
FN1016
FP1016
2SD2061



G D S

2SK2723

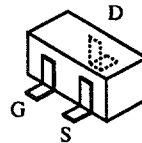

2SK2158

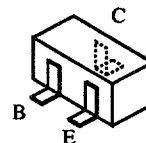

2SA1235F
2SC2714
2SC3052F
CSD1306E
2SC2412
DTA143EK

2SA1037
DTA144EK
DTA114YK
DTC114EK
DTA143XK
DTA124EK
DTA114EK
DTC114YK

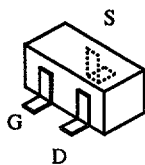

2SK543



E C B

DTA114ES
DTA114YS

BLOCK DIAGRAM

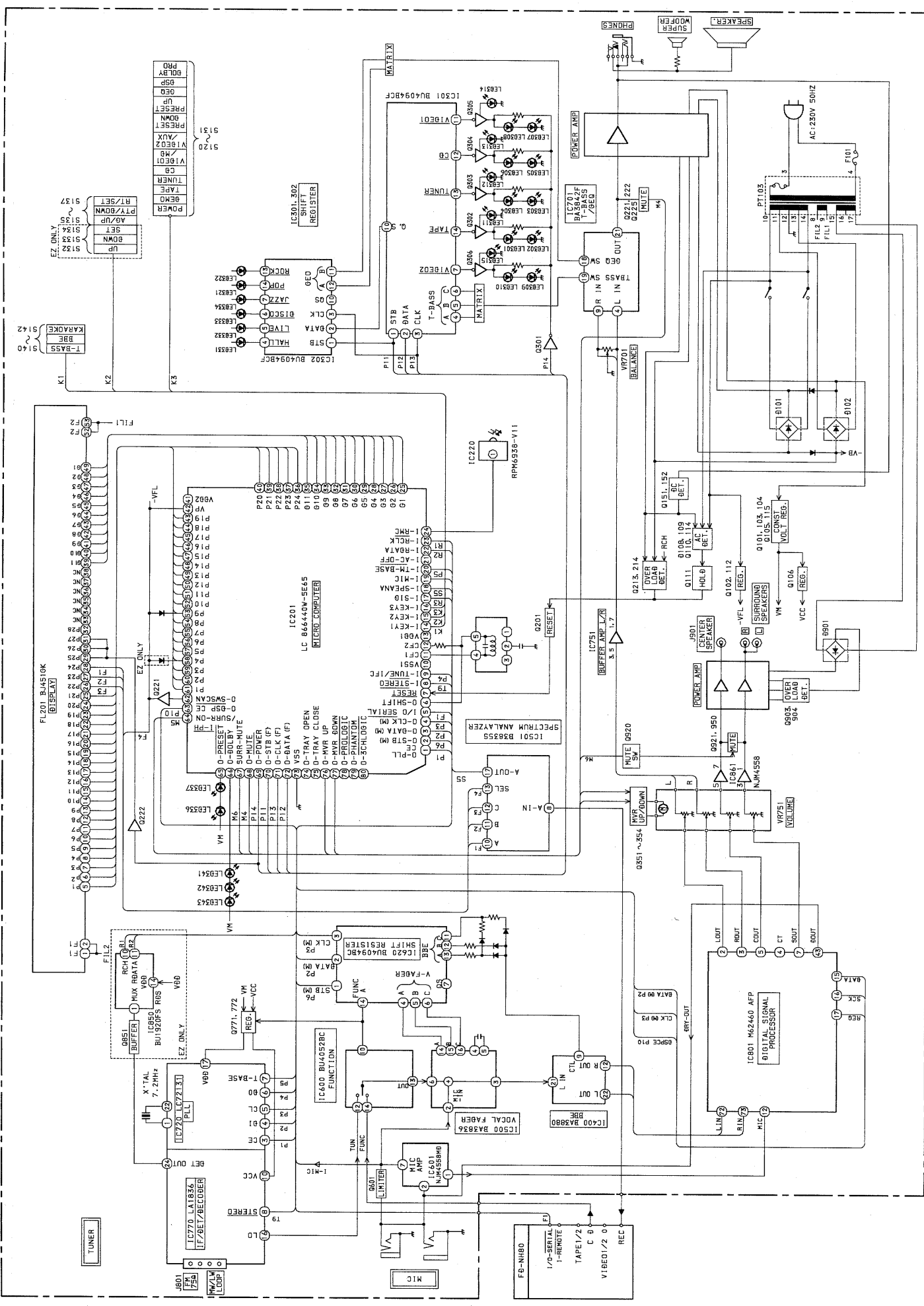

A

B

C

D

E

F

G

H

I

J

A MAIN C.B

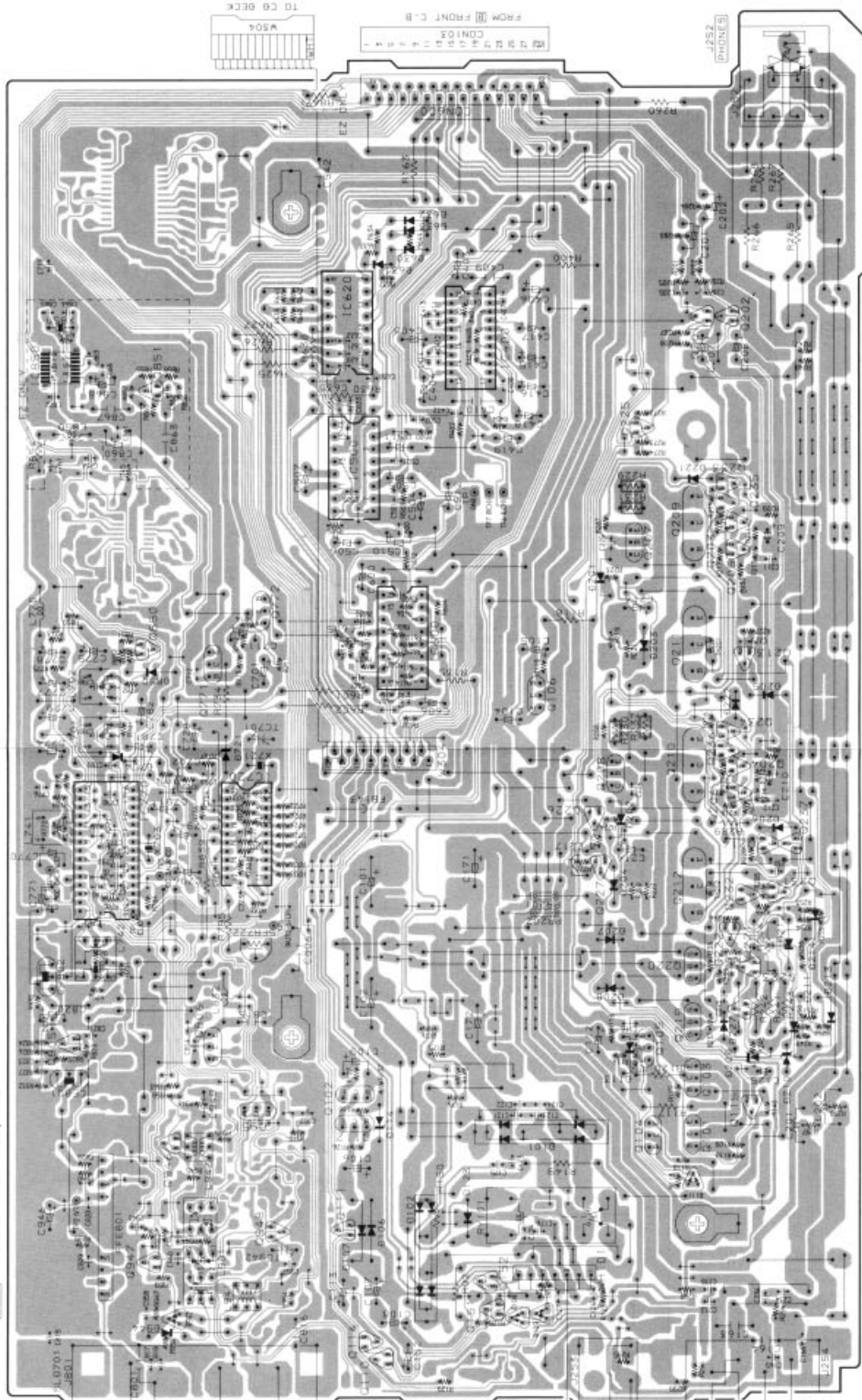

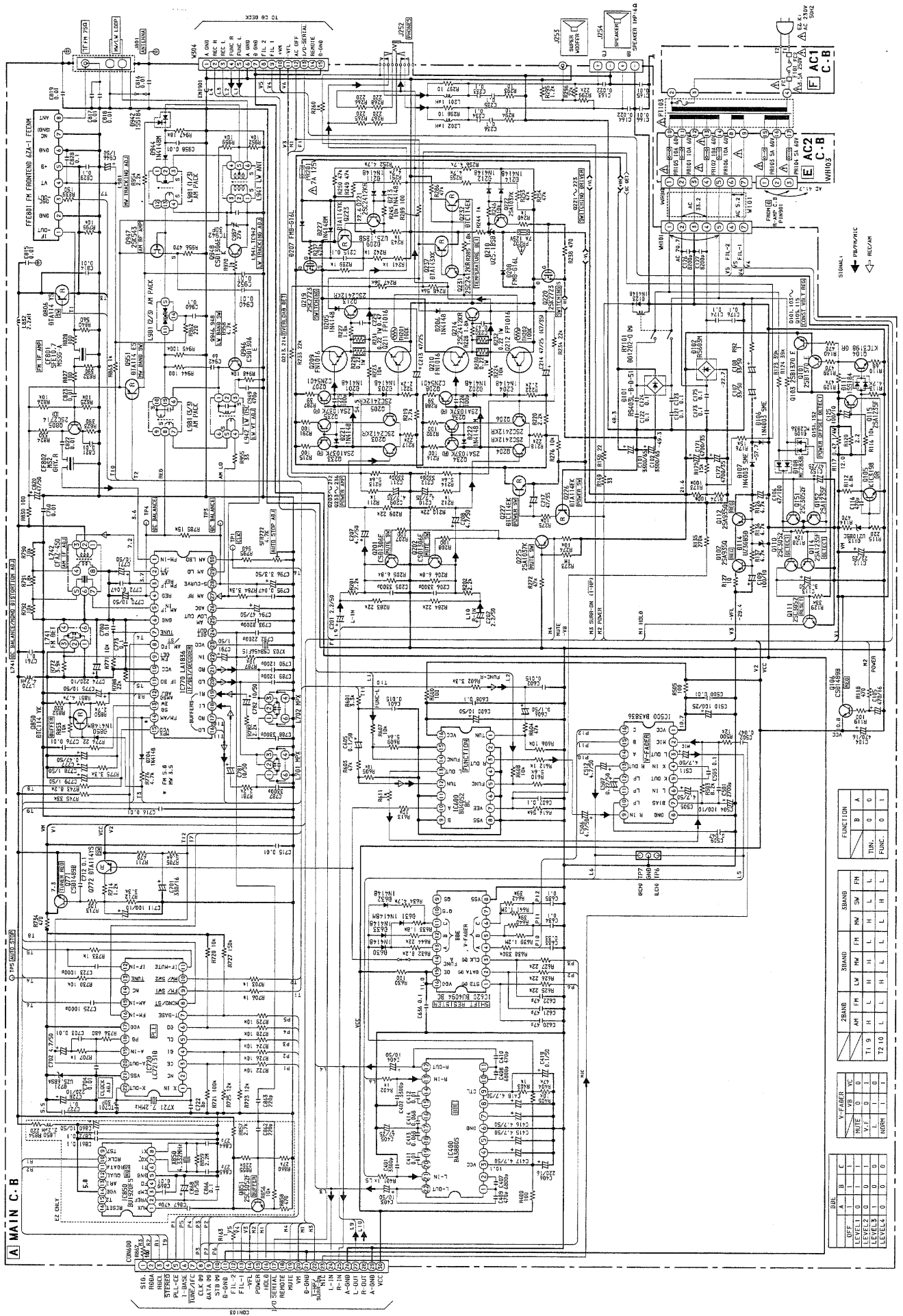

UNIT	A	B	C	V-FABER	28AND	38AND	58AND	FUNCTION
OFF	1	1	1	VC				A
LEVEL 1	0	1	1	WRITE	PH	PH	PH	B
LEVEL 2	0	0	0	VI	LH	LH	LH	C
LEVEL 3	0	0	0	VI	LH	LH	LH	D
LEVEL 4	0	0	0	NORM	LH	LH	LH	E
					LH	LH	LH	F

1 2 3 4 5 6 7 8 9 10 11 12 13 14

B FRONT C.B.

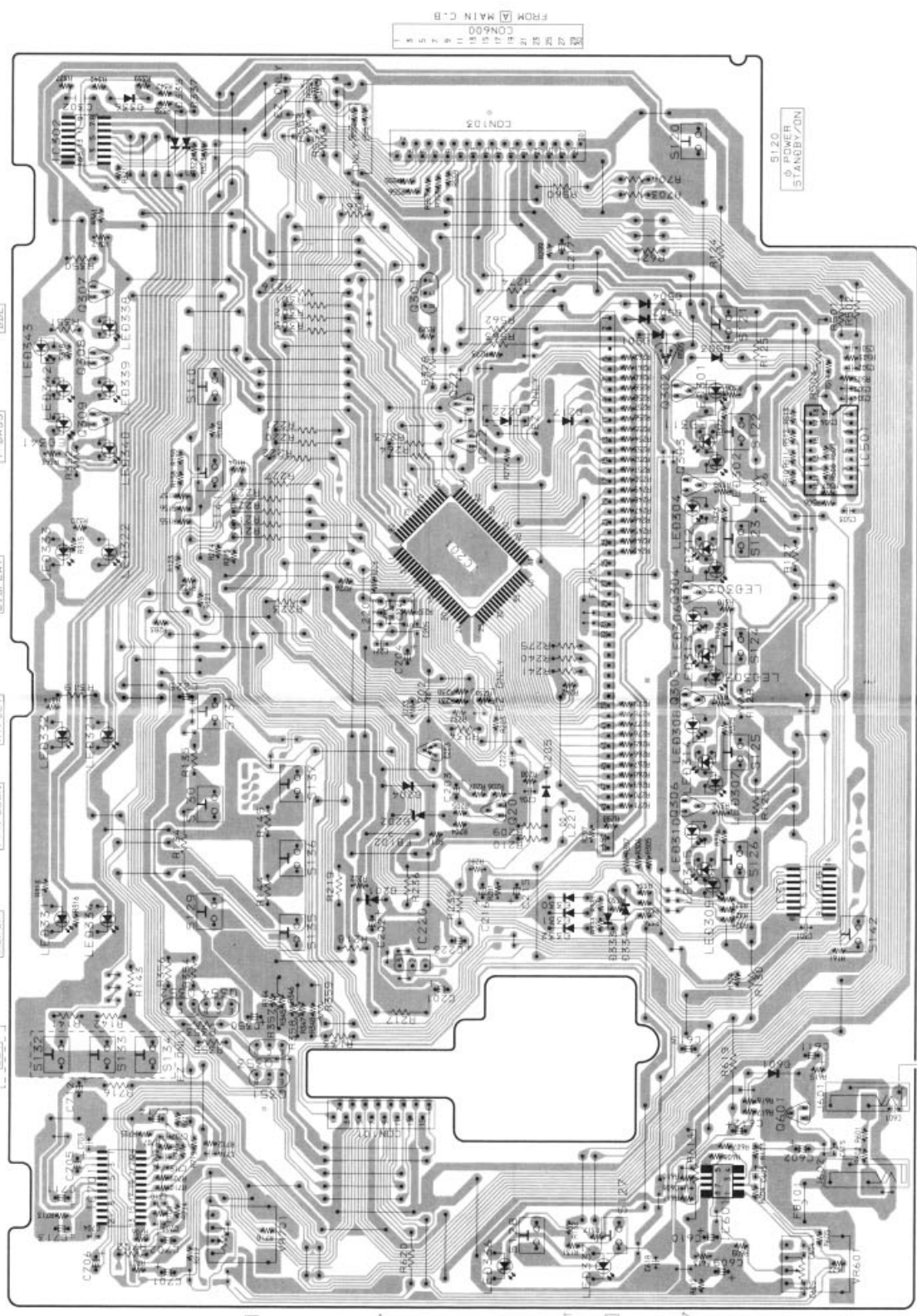

- LED351 HALL
- LED352 LIVE
- LED353 BOLBY
- LED354 ARZE
- LED355 PHANTOM
- LED356 PHONOLOGIC
- LED357 ROCK
- LED358 PHONOLOGIC
- LED359 PHONOLOGIC

- S129 [SEG]
- S130 [OSP]
- S131 [BOLBY PHONOLOGIC]
- S132 [TUNING UP]
- S133 [TUNING DOWN]
- S134 [SET]
- S135 [AG/UP]
- S136 [PTY/DOWN]
- S137 [RT/SET]
- S140 [T-BASS]
- S141 [BRE]

- FL201 [DISPLAY]
- VR701 [BALANCE]
- CON1D2 [TO MFR C.B.]
- CON1D3 [FROM MAIN C.B.]
- CON1D4 [CON600]
- CON1D5 [1-27]

- S126 [KARAOKE/VIDEO/AUX]
- S127 [STATION PRESET]
- S128 [UP]
- S129 [DOWN]
- S134 [MIC-1]
- S135 [MIC-2]
- S136 [MIC-3]
- S137 [TUNER]
- S138 [TAPE]
- S139 [BEMD]

- S140 [POWER STANDBY/ON]
- S141 [VR601 MIC MIXING MAX-MIN]
- S142 [LED309, ST0, 315, LED307, 308, 314, LED305, 306, 315, LED303, 304, 312, LED301, 302, 311]

1 2 3 4 5 6 7 8 9 10 11 12 13 14

C MVR C.B

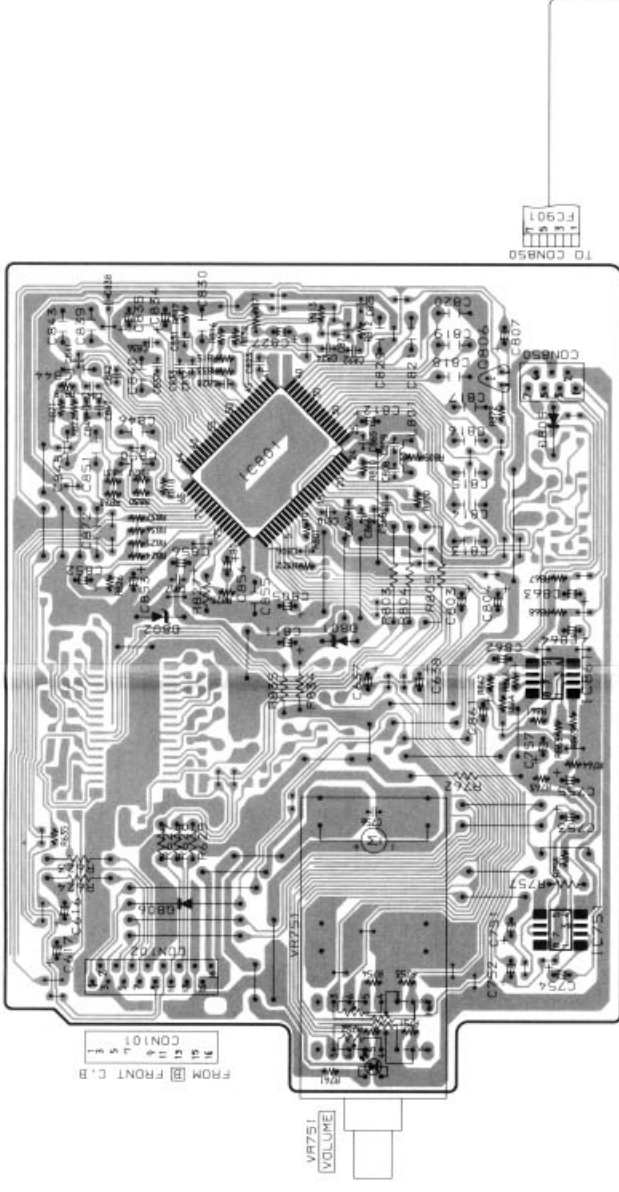

D R-AMP C.B

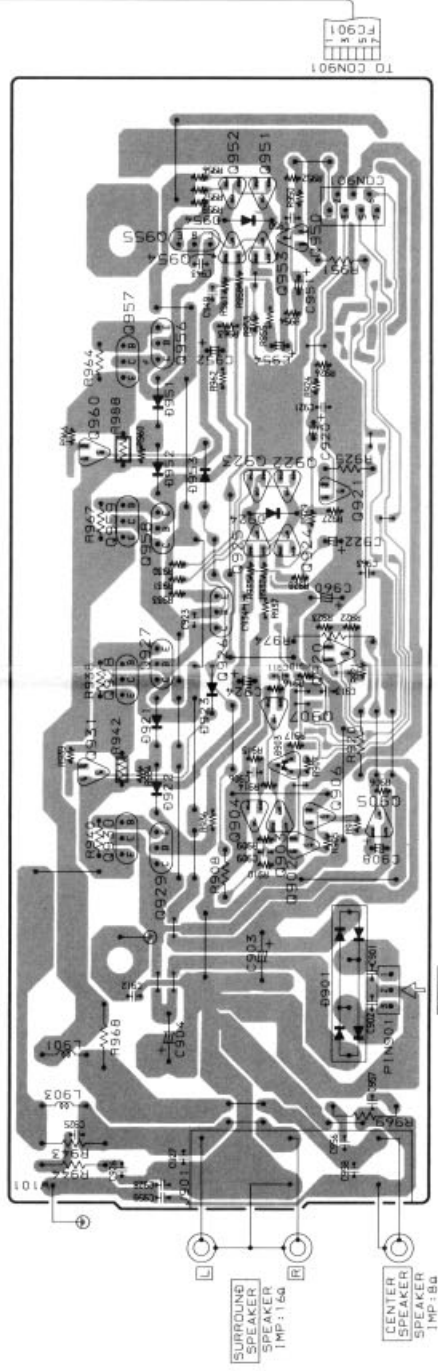

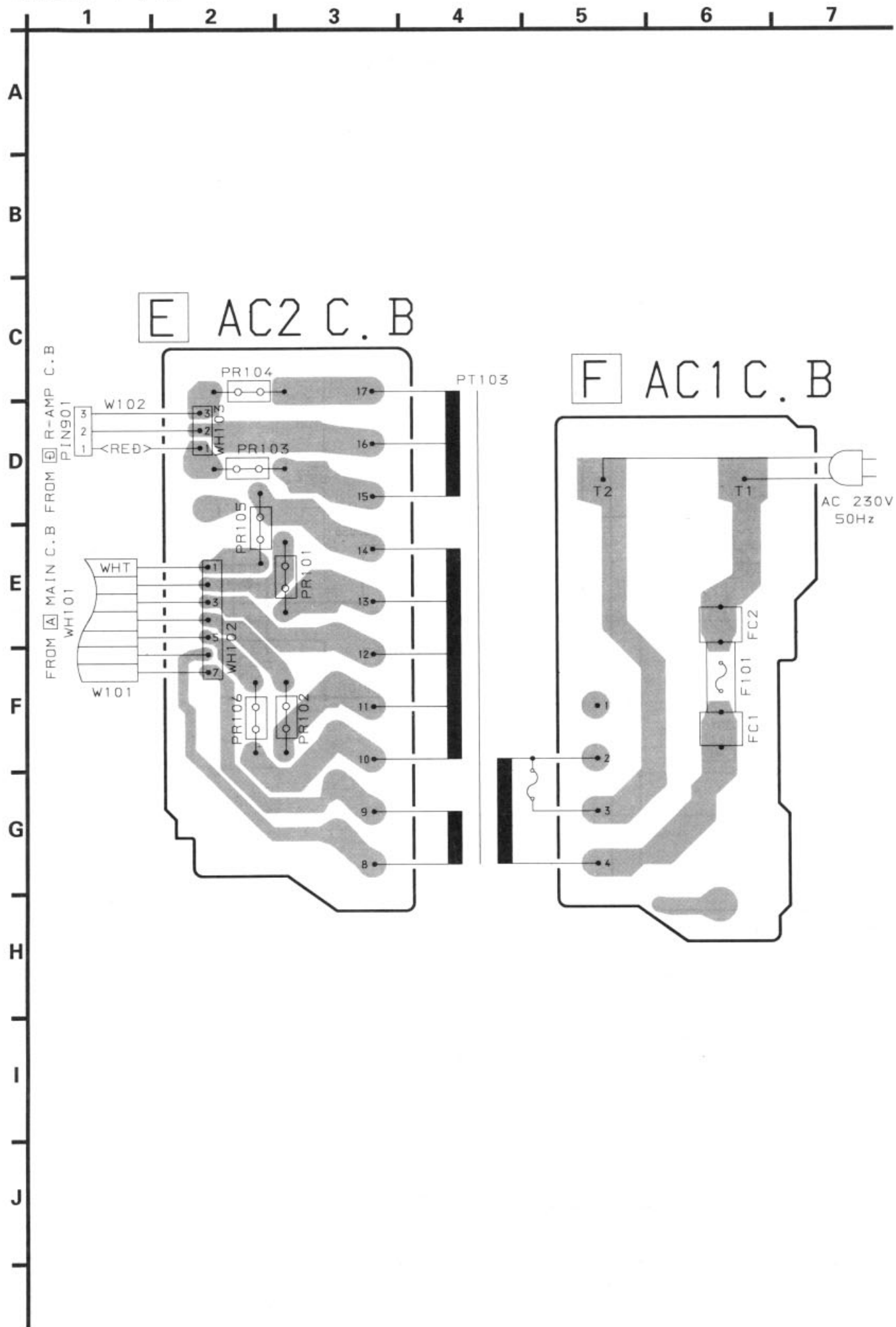

IC DESCRIPTION

IC, M62460AFP

Pin No.	Pin Name	I/O	Description
1	NGC1	I	Noise sequencer 1.
2	L OUT	O	Selected output signal from BY-PASS,PLOLOGIC,OTHER and MUTE by selector.
3	R OUT	O	
4	CT	O	When it is PHANTOM MODE, CT do not output.
5	C OUT	O	C OUT is output from C Trimmer.
6	ST	O	ST output is selected from BNRout, Dout and 3STEREO/MUTE.
7	S OUT	O	SOUT is output from S.Trimmer.
8	CMC	I	Center mode control.
9	SMRO	O	This is a amplifier to control mixed level of surround output with external resistance.
10	SMRI	I	
11	A-GND	-	Connect to GND.
12	MIC IN	I	Microphone input with ECHO MODE.
13	D-VDD	-	Digital power supply.
14	TEST-CNT	-	Fixed to GND
15	DATA	I	Input via serial data from MCU.
16	SCK		
17	REQ		
18	LO1	O	Open collector output pin.
19	LO2		
20	LO3		
21	X-IN	I	Connect a 4-MHz ceramic filter.
22	X-OUT	O	
23	D-VSS	-	Digital GND.
24	A-VSS	-	Analog GND.
25	AVDD	-	Analog power supply.
26	VREFD	O	1/2 Vcc output Connect a filter capacitor.
27	MIX OUT	O	Front signal of delay that is S', L + R, L - R and MIC output
28	DELAY IN	I	This is a delay input. Input by AC cupping.
29	LPF1 IN1	I	Low pass filter 1 input 1.
30	LPF1 IN2	I	Low pass filter 1 input 2.
31	LPF1 OUT	O	Low pass filter 1 output.
32	AD INT IN	I	A/D INTEGRAL CAL input.
33	AD INT OUT	O	A/D INTEGRAL CAL output.
34	AD CONT		A/D control.
35	DA CONT		D/A control.
36	DA INT IN	I	D/A INTEGRAL CAL input.
37	DA INT OUT	O	D/A INTEGRAL CAL output.
38	LPF2 IN1	I	Low pass filter 2 input 1.
39	LPF2 IN2	I	Low pass filter 2 input 2.
40	LOF2 OUT	O	Delay signal output .
41	VOL OUT	O	This is output of a delay volum that possible to control + 3dB~∞.

Pin No.	Pin Name	I/O	Description
42	DELAY IN	I	Delay signal input to a mixing amplifier.
43	DELAY OUT	O	Delay signal output from a mixing amplifier.
44	FBIN EC	I	Feedback signal input with ECHO MODE.
45	FBIN SU		Feedback signal input with SURROUND MODE.
46	S'OUT	O	Surround channel output precedent to delay generator. Always outputs signals, irrespectiv of the operation mode (2-/3-/4-channel).
47	DBIN	I	This amplifler compornent 7KHz-LPF with external resistances and capacitors. LPF output is conected to input of Modified BNR.
48	LPIN	O	
49	DBC1	I	Modified B-type NR decorder.
50	DBC2	I	Modified B-type NR decorder.
51	DBC3	I	Modified B-type NR decorder.
52	PSC3	I	Dual-time constant and threshold switches.
53	PSC6	I	Dual-time constant and threshold switches.
54	PSC2	I	Dual-time constant and threshold switches.
55	PSC5	I	Dual-time constant and threshold switches.
56	PSC1	I	Dual-time constant and threshold switches.
57	PSC4	I	Dual-time constant and threshold switches.
58	RLC5	I	Log difference amplifiers.
59	RLC2	I	Log difference amplifiers.
60	RLC1	I	Log difference amplifiers.
61	RLC4	I	Log difference amplifiers.
62	RLC7	I	Full wave rectifier.
63	RLC3	I	Full wave rectifier.
64	RLC8	I	Full wave rectifier.
65	RLC6	I	Full wave rectifier.
66	LL1	I	Lch BPF in.
67	LBPF	O	Lch BPF feedback out.
68	RLI	I	Rch BPF in.
69	RBPF	O	Rch BPF feedback out.
70	LT	O	Lch selector #1 out.
71	RT	O	Rch selector #1 out.
72	L IN	I	Lch signal input.
73	R IN	I	Rch signal input.
74	HOLDC	I	Auto input balance control.
75	AVCC	-	Analog power supply.
76	VREFA	I	Vref in.
77	VREFG	I	Vref out.
78	IREF	I	Iref in.
79	NGC3	I	Noise sequencer 3.
80	NGC2	I	Noise sequencer 2.

Pin No.	Pin Name	I/O	Description																								
1	XIN	I/O	A crystal oscillator (7.2MHz) is connected between these pins.																								
22	XOUT																										
2	NC	-	Not used.																								
3	CE	I	To enable the IC. Active "H".																								
4	DI	I	Digital data input from CPU (LC866440W-5E65) when relevant key is operated. Active "H".																								
5	CLK	I	To clock in the data DI.																								
6	DO	O	Digital data output to CPU (LC866440W-5E65).																								
7	TM-BASE	O	Outputs a reference clock signal (8Hz) for the clock.																								
8	MONO / BEAT	O	Outputs "H" when MONO / BEAT is switched.																								
9	FM / AM	O	Output "L" or "H" as follows: <table border="1" style="margin-left: 20px;"> <thead> <tr> <th colspan="2">2 BAND</th> <th colspan="3">3 BAND</th> <th colspan="3">3 BAND</th> </tr> <tr> <th>AM</th> <th>FM</th> <th>LW</th> <th>MW</th> <th>FM</th> <th>MW</th> <th>SW</th> <th>FM</th> </tr> </thead> <tbody> <tr> <td>H</td> <td>L</td> <td>H</td> <td>H</td> <td>L</td> <td>H</td> <td>L</td> <td>L</td> </tr> </tbody> </table>	2 BAND		3 BAND			3 BAND			AM	FM	LW	MW	FM	MW	SW	FM	H	L	H	H	L	H	L	L
2 BAND		3 BAND			3 BAND																						
AM	FM	LW	MW	FM	MW	SW	FM																				
H	L	H	H	L	H	L	L																				
10	MW	O	Outputs "L" or "H" as follows: <table border="1" style="margin-left: 20px;"> <thead> <tr> <th colspan="2">2 BAND</th> <th colspan="3">3 BAND</th> <th colspan="3">3 BAND</th> </tr> <tr> <th>AM</th> <th>FM</th> <th>LW</th> <th>MW</th> <th>FM</th> <th>MW</th> <th>SW</th> <th>FM</th> </tr> </thead> <tbody> <tr> <td>L</td> <td>L</td> <td>H</td> <td>L</td> <td>L</td> <td>L</td> <td>H</td> <td>L</td> </tr> </tbody> </table>	2 BAND		3 BAND			3 BAND			AM	FM	LW	MW	FM	MW	SW	FM	L	L	H	L	L	L	H	L
2 BAND		3 BAND			3 BAND																						
AM	FM	LW	MW	FM	MW	SW	FM																				
L	L	H	L	L	L	H	L																				
11	IF-MUTE	O	To control internal counter.																								
12	IFIN	I	General purpose counter input.																								
13	TUNE	I	Receives "L" when station is tuned.																								
14	NC	-	Not used.																								
15	A MIN	I	Receives the AM local oscillator frequency signal.																								
16	F MIN	I	Receives the FM local oscillator frequency signal.																								
17	VDD	-	Supply power to IC (+5V).																								
18	PD	O	PLL charge pump output.																								
19	AIN	I	The MOS transistor for PLL active low pass filter.																								
20	AOUT	O																									
21	VSS	-	Ground.																								

IC, LC866440W-5E65

Pin No.	Pin Name	I/O	Description
1	O-PLLCE	O	PLL IC chip enable output.
2	O-STB(M)	O	Main shift register, data latch strobe output.
3	O-DATA(M)	O	Main shift register/PLL/DSP related, data output.
4	O-CLK(M)	O	Main shift register/PLL/DSP related, data transfer clock output.
5	I/O SERIAL	I/O	FD microprocessor, I/O serial.
6	O-SHIFT	O	Microprocessor clock shift output during tuner reception.
7	RESET	I	Reset input (Reset at "L").
8	I-STEREO	I	Tuner stereo sensing input
9	I-TUNE/IFC	I	Tuner, SD sensing input/IF count serial data input.
10	VSS1	-	GND.
11	CF1	-	5.76MHz oscillator.
12	CF2	-	5.76MHz oscillator.
13	VDD1	-	Power supply input.
14~16	I-KEY 1~3	I	Key 1 ~ 3 A/D input.
17	I-SIG	I	Signal level A/D input for RDS. (Not used)
18	I-SPEANA	I	Spectrum analyzer level A/D input.
19	I-MIC	I	Mic level A/D input for auto vocal fader.
20	I-TMBASE	I	Reference clock input for watch (Automatically supporting 8/50/60 Hz).
21	I-AC OFF	I	Power failure sensing input (Hold at "L").
22	I-RDATA	I	Data input for RDS.
23	I-RCLK	I	Clock input for RDS.
24	I-RMC	I	System remote control signal input (active low).
25~35	G1~G11	O	FL grid output G1~G11.
36~40	P24~P20	O	FL segment output P24~P40.
41	VDD2	-	Power supply input.
42	VP	-	Power supply for display.
43~48	P19~P14	O	FL segment output P19~14.
49	P13	O	FL segment output /Diode input supporting OIRT.
50	P12	O	FL segment output /Diode input supporting.
51	P11	O	FL segment output /Diode input supporting NTSC.
52	P10	O	FL segment output /Diode input supporting PRO.
53	P9	O	FL segment output /Diode input supporting LW.
54	P8	O	FL segment output /Diode input supporting SW.
55	P7	O	FL segment output /Diode input supporting AM 10K.
56	P6	O	FL segment output /Diode input supporting AM STEREO.
57	P5	O	FL segment output /Diode input supporting FM JPN.
58	P4	O	FL segment output /Diode input supporting RDS.
59	P3	I/O	FL segment output /Diode input supporting BBE.
60	P2	I/O	FL segment output /Diode input supporting DSP.
61	P1	I/O	FL segment output /Diode input supporting K-CON.
62	O-SWSCAN	O	CD turntable reverse direction rotation output/SW scan (timing output).
63	O-DSP CE	O	CD turntable forward direction rotation output/DSP chip enable.

Pin No.	Pin Name	I/O	Description
64	SUR ON	O	SUR ON(output at "H").
65	O-PRESET LED	O	Preset.
66	O-DOLBY	O	DOLBY LED control.
67	SURR-MUTE	O	Surround mute.
68	O-MUTE	O	System Mute ON/OFF output.
69	O-POWER	O	System power supply ON/OFF output.
70	O-STB(F)	O	Front shift register, data latch strobe output.
71	O-CLK(F)	O	Front shift register, data clock output.
72	O-DATA(F)	O	Front shift register, data output.
73	VSS	-	GND.
74	O-TRAY OP	O	CD tray open output.
75	O-TRAY CL	O	CD tray close output.
76	O-VR UP	O	Vol up output.
77	O-VR DN	O	Vol down output.
78~80	NC	-	Not used.

PRACTICAL SERVICE FIGURE

<TUNER SECTION>

<FM SECTION>

IHF Sensitivity :
(THD 3%) 6dB±6dB
[at 87.5 / 98.0 / 108.0MHz]

S/N 50dB Quieting sensitivity :
Less than 36dB
[at 87.5 / 98.0 / 108.0MHz]

Signal to noise ratio :
More than 66dB [STEREO]
More than 72dB [MONO]
[at 98.0MHz]

Distortion :
Less than 1.2% [at 98.0MHz]

Auto stop level :
20dB +10/-5dB [at 98.0MHz(K)]
25dB +10/-5dB [at 98.0MHz(EZ)]

Stereo separation :
More than 20dB [at 98.0MHz]

Intermediate frequency :
10.7MHz

<MW (AM) SECTION>

Sensitivity :
(S/N 20dB) Less than 60dB
[at 603kHz]
Less than 58dB
[at 999kHz/1404kHz]

Signal to noise ratio :
More than 36dB
[at 999kHz]

Distortion :
Less than 1.5%
[at 999kHz]

Auto stop level :
Less than 60dB
[at 999kHz]

Intermediate frequency :
450kHz

<LW SECTION>

Sensitivity :
(S/N 20dB) Less than 70dB
[at 144kHz]
Less than 66dB
[at 198kHz/290kHz]

Signal to noise ratio :
More than 34dB
[at 198kHz]

Intermediate frequency :
450kHz

ADJUSTMENT <TUNER>

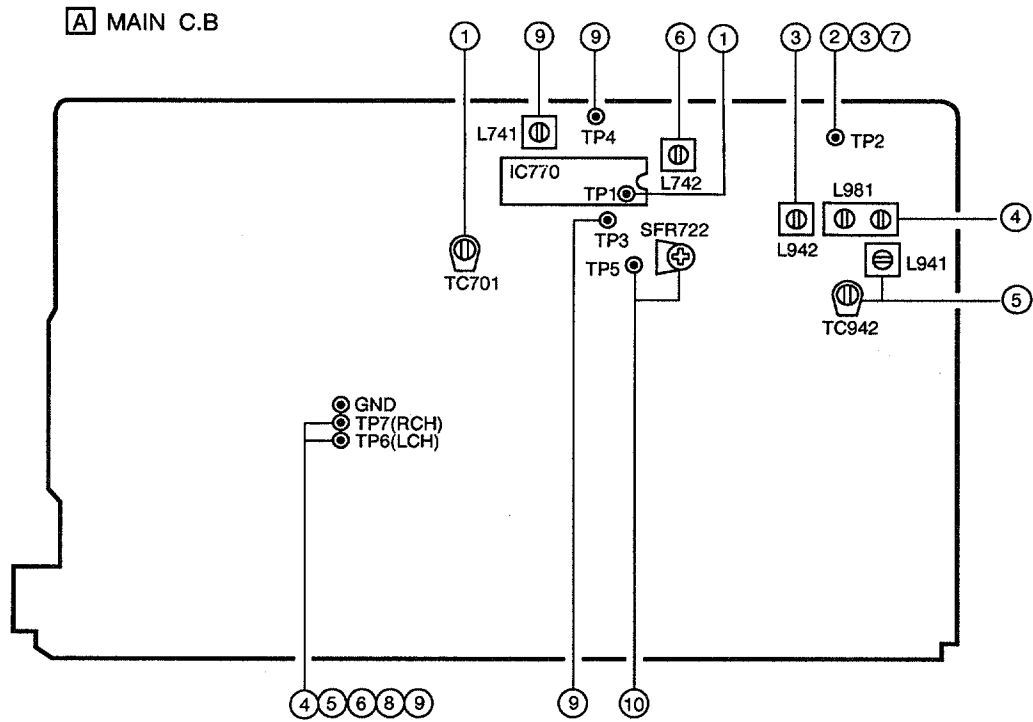

< TUNER SECTION >

1. Clock Adjustment
 Settings : • Test point : TP1 (CLK)
 • Adjustment location : TC701
 Method : Set to MW(AM) 1602kHz, and adjust TC701 so that the test point becomes 2052kHz ± 0.01 kHz.
2. MW(AM) VT Check
 Settings : • Test point : TP2 (VT)
 Method : Set to MW(AM) 1602kHz and check that the test point is 6.0V ± 1.0 V.
3. LW VT Adjustment
 Settings : • Test point : TP2(VT)
 • Adjustment location : L942
 Method : Set to LW 144kHz and adjust L942 so that the test point becomes 1.3 ± 0.05 V.
4. MW(AM) Tracking Adjustment
 Settings : • Test point : TP6(Lch), TP7(Rch)
 • Adjustment location : L981
 Method : Set to MW(AM) 999kHz and adjust L981 so that the test point becomes maximum.
5. LW Tracking Adjustment
 Settings : • Test point : TP6(Lch), TP7(Rch)
 • Adjustment location : L941, TC942
 Method : Set to LW 144kHz(290kHz) and adjust L941(TC 942) so that the test point becomes maximum.
6. AM(MW) IF Adjustment
 Settings : • Test point : TP6(Lch), TP7(Rch)
 L742.....450kHz
7. FM VT Check
 Settings : • Test point : TP2 (VT)
 Method : Set to FM 87.5MHz and check that the test point is more than 1.5V. Then set to FM 108MHz and check that the test point is less than 8.2V.
8. FM Tracking Check
 Settings : • Test point : TP6(Lch), TP7(Rch)
 Method : Check that the test point is 3~12dB (DISTORTION: 3%) at FM 98.0MHz.
9. DC Balance / Mono Distortion Adjustment
 Settings : • Test point : TP3, TP4 (DC balance)
 : TP6, TP7 (Mono Distortion)
 • Adjustment location : L741
 • Input level : 54dB
 Method : Set to FM 98.0MHz and adjust L741 so that the voltage between TP3 and TP4 becomes 0V ± 0.04 V.
 Next, check that the distortion is less than 1.3%.
10. Auto Stop Level Adjustment
 Settings : • Test point : TP5
 • Adjustment location : SFR722
 • Input level : 54dB
 Method : Set to FM 98.0MHz and adjust voltage low (about 0.1V) by SFR722. Then check voltage high (about 7.0V) by SSG level 2dB down.
11. Auto Stop Level Check
 MW
 Settings : • Input level : Variable
 Method : Check the auto stop at MW 999kHz and the level is 50dB ± 10 dB.
 FM
 Settings : • Input level : Variable
 Method : Check the auto stop at FM 98.0MHz and the level is 20dB ~ 35dB <EZ>, 15 ~ 30dB <K>.

FL GRID ASSIGNMENT AND ANODE CONNECTION

FL, BJ451GK

GRID ASSIGNMENT

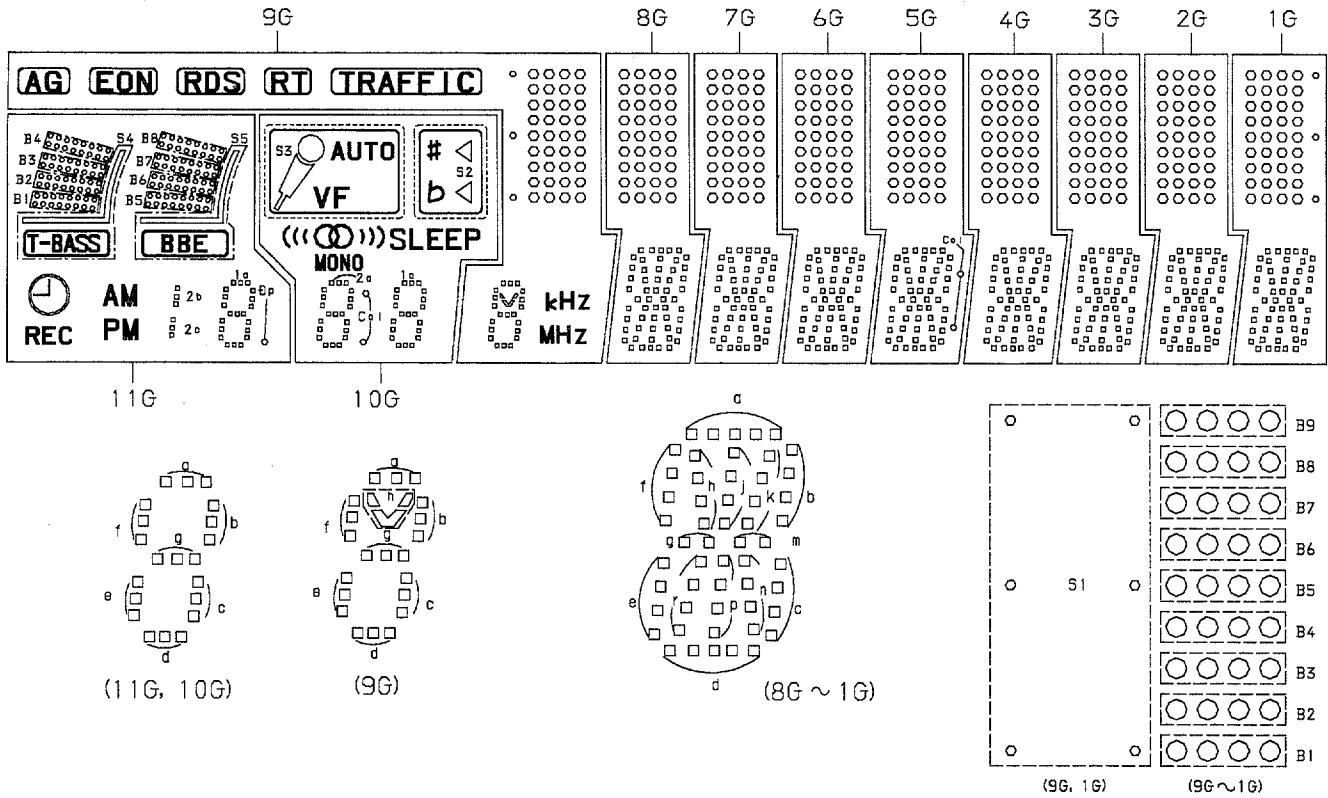

ANODE CONNECTION

	11G	10G	9G	8G	7G	6G	5G	4G	3G	2G	1G
P1	2b, 2c	S3	B9	B9	B9	B9	B9	B9	B9	B9	B9
P2	1a	AUTO	B8	B8	B8	B8	B8	B8	B8	B8	B8
P3	1b	<(High)	B7	B7	B7	B7	B7	B7	B7	B7	B7
P4	1f	<(Low)	B6	B6	B6	B6	B6	B6	B6	B6	B6
P5	1g	((ω))	B5	B5	B5	B5	B5	B5	B5	B5	B5
P6	1c	SLEEP	B4	B4	B4	B4	B4	B4	B4	B4	B4
P7	1e	MONO	B3	B3	B3	B3	B3	B3	B3	B3	B3
P8	1d	○	B2	B2	B2	B2	B2	B2	B2	B2	B2
P9	—	2a	B1	B1	B1	B1	B1	B1	B1	B1	B1
P10	—	2b	TRAFFIC	a	a	a	a	a	a	a	a
P11	B8	2f	RT	h	h	h	h	h	h	h	h
P12	B7	2g	RDS	J	J	J	J	J	J	J	J
P13	B6	2c	EON	K	K	K	K	K	K	K	K
P14	B5	2e	AG	b	b	b	b	b	b	b	b
P15	B4	2d	h	f	f	f	f	f	f	f	f
P16	B3	1a	a	m	m	m	m	m	m	m	m
P17	B2	1b	b	g	g	g	g	g	g	g	g
P18	B1	1f	f	c	c	c	c	c	c	c	c
P19	AM	1g	g	e	e	e	e	e	e	e	e
P20	PM	1c	c	r	r	r	r	r	r	r	r
P21	Ⓜ	1e	e	p	p	p	p	p	p	p	p
P22	REC	1d	d	n	n	n	n	n	n	n	n
P23	—	Col (Low)	KHZ	d	d	d	d	d	d	d	d
P24	Ⓟp	Col (High)	MHZ	—	—	—	col	—	—	—	—
P25	—	—	S1	—	—	—	—	—	—	—	S1
P26	S4	—	—	—	—	—	—	—	—	—	—
P27	S5	—	—	—	—	—	—	—	—	—	—
P28	—	S2	—	—	—	—	—	—	—	—	—

IC BLOCK DIAGRAM

IC, LA1836

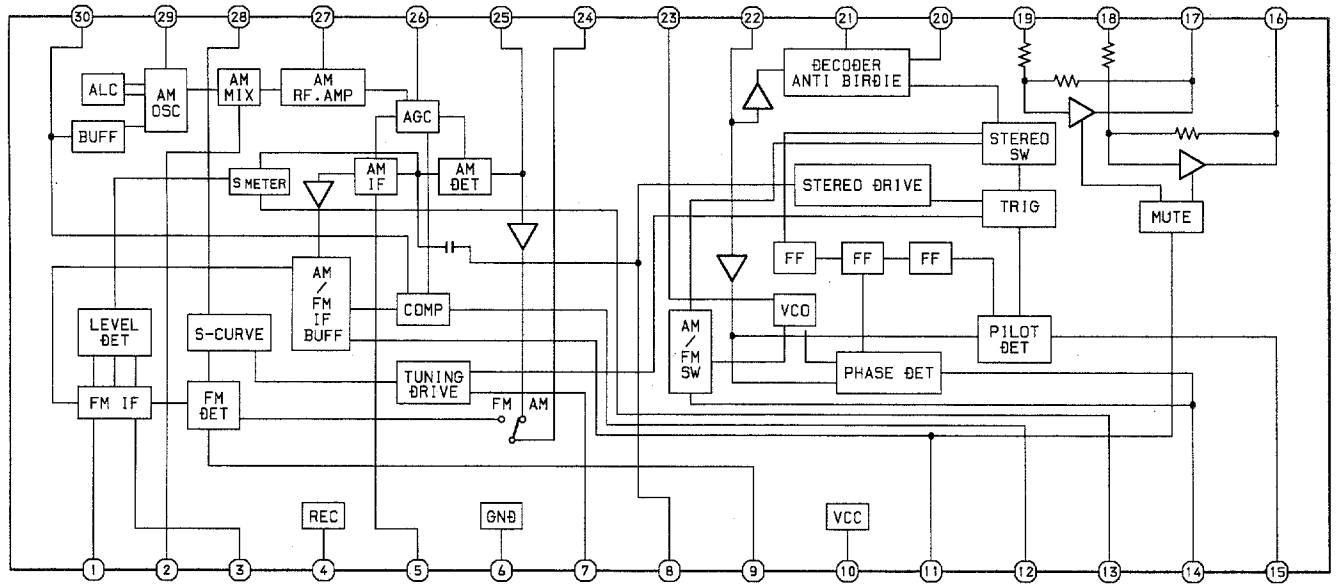

IC, BU4052BCP

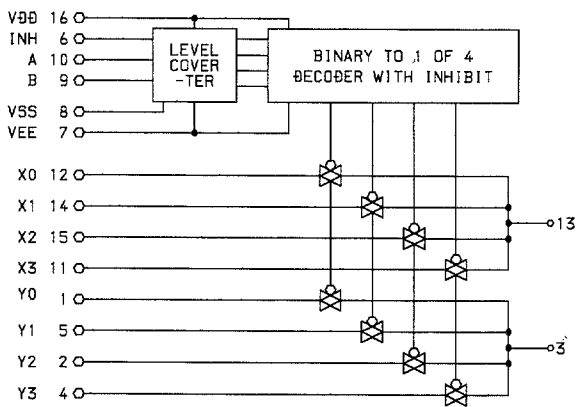

TRUTH TABLE

INHIBIT	A	B	ON SWITCH
L	L	L	X0 Y0
L	H	L	X1 Y1
L	L	H	X2 Y2
L	H	H	X3 Y3
H	X	X	NONE

IC, BU1920FS

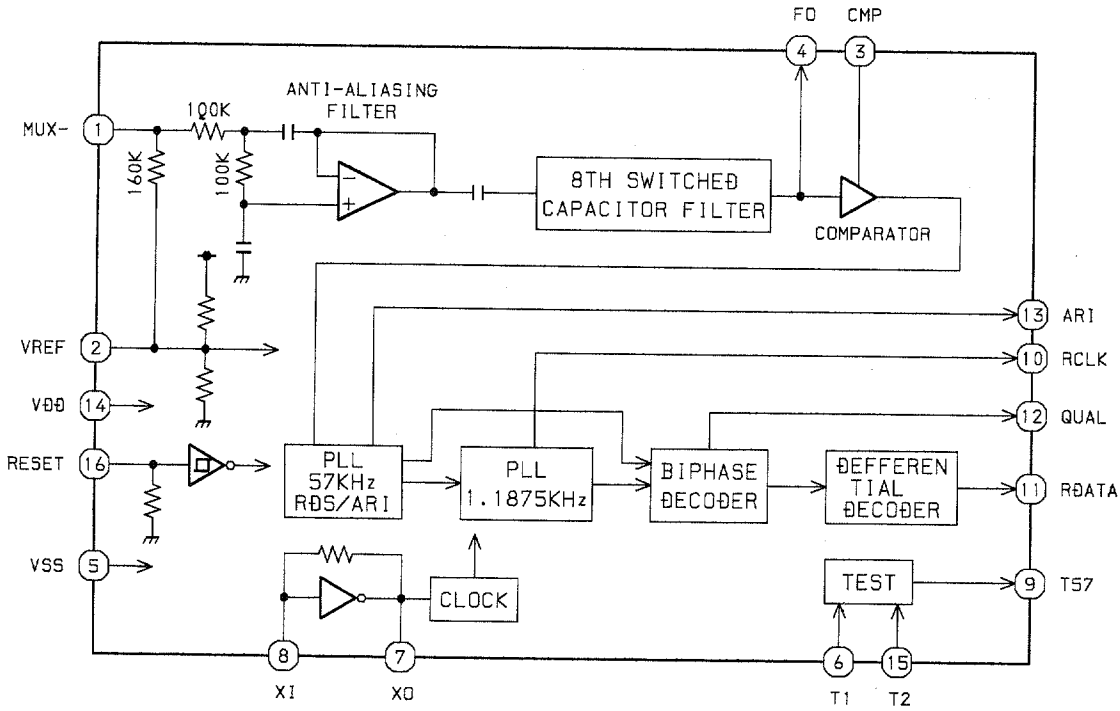

IC, BU4094BCP / BCF

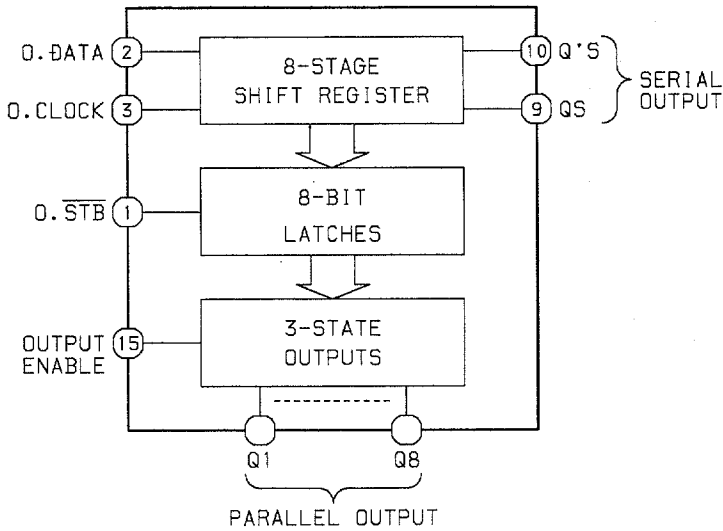

- Q1: 0. DOLBY ON
- Q2: 0. DOLBY C
- Q3: 0. EXT.REC
- Q4: 0. INT.REC
- Q5: 0. PLAY
- Q6: 0. PB2
- Q7: 0. LEØ
- Q8: 0. RMT

TRUTH TABLE

CLOCK	OUTPUT ENABLE	STROBE	DATA	PARALLEL OUTPUTS		SERIAL OUTPUTS	
				Q1	Qn	Q5	Q'S
\bar{f}	L	x	x	Z	Z	Q7	NO CHG.
\bar{f}	L	x	x	Z	Z	NO CHG.	Q5
\bar{f}	H	L	x	NO CHG.	NO CHG.	Q7	NO CHG.
\bar{f}	H	H	L	L	Qn-1	Q7	NO CHG.
\bar{f}	H	H	H	H	Qn-1	Q7	NO CHG.
\bar{f}	H	x	x	NO CHG.	NO CHG.	NO CHG.	Q5

Z = HIGH IMPEDANCE
 x = DON'T CARE

IC, BA3842F

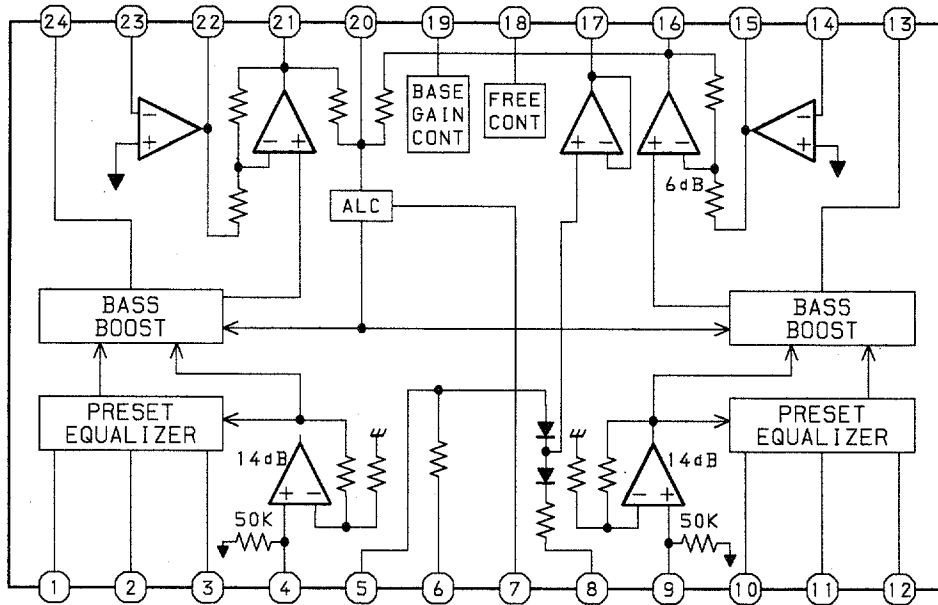

IC, BA3880S

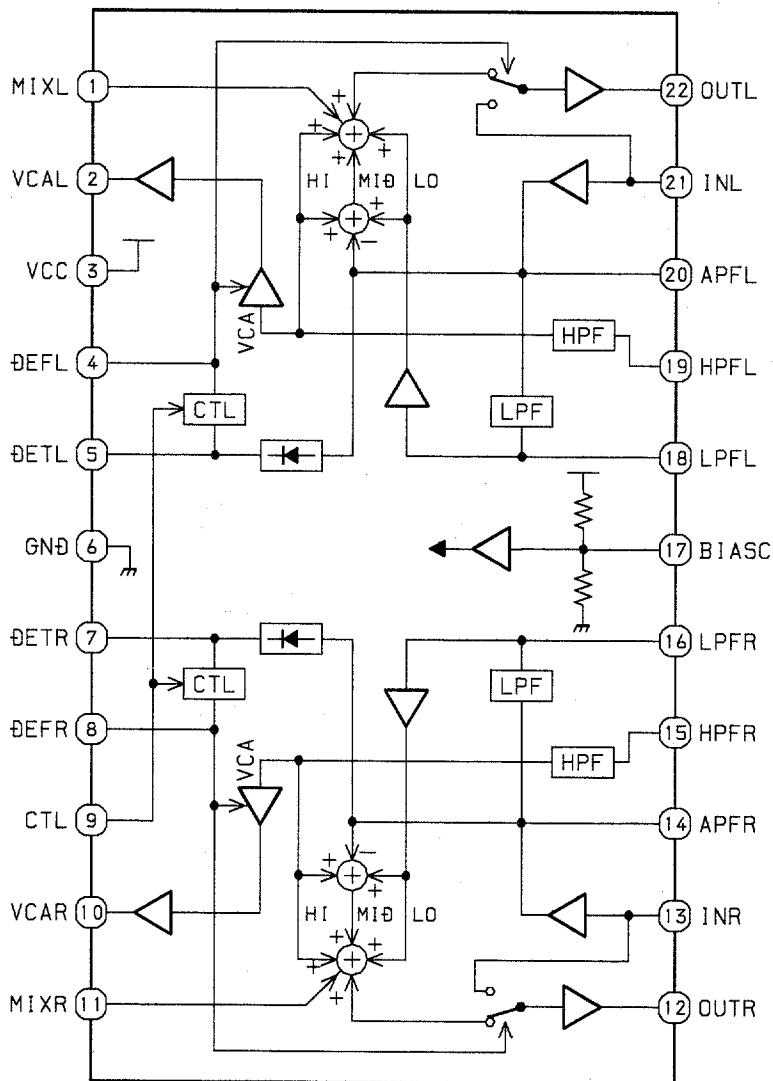

IC, BA3836

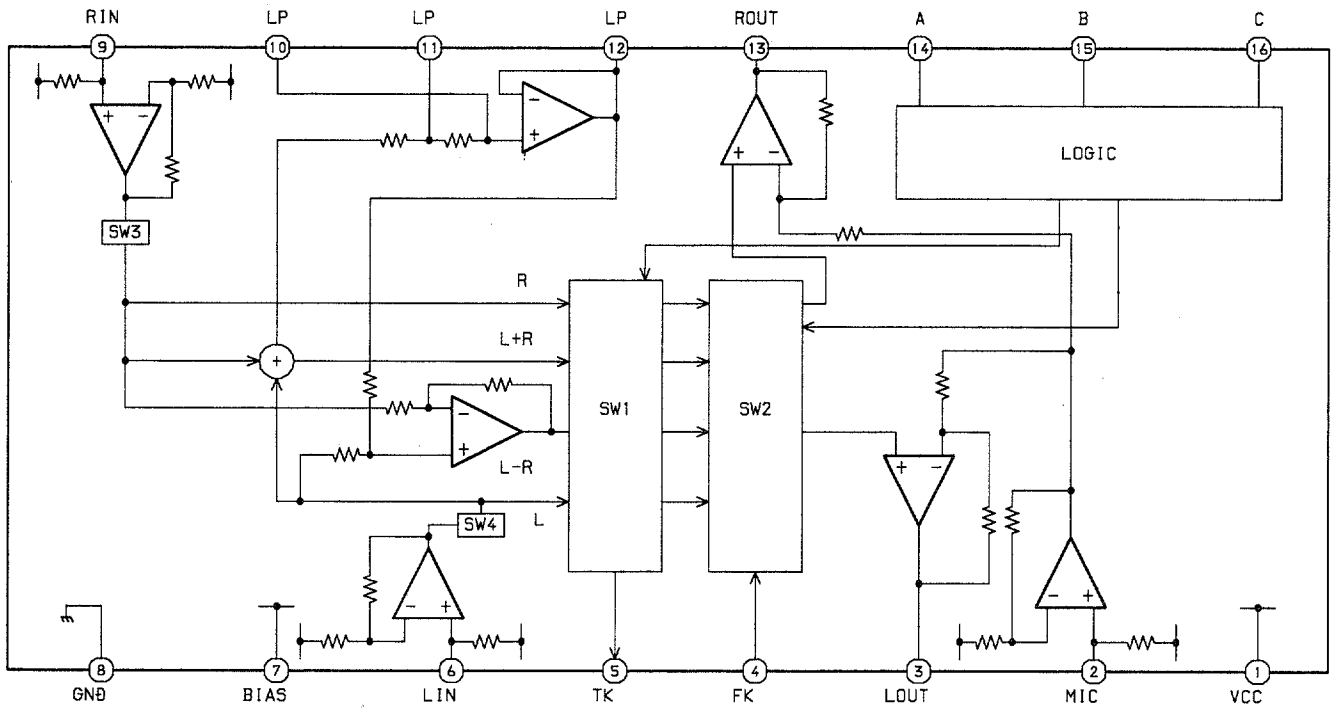

IC, BA3835S

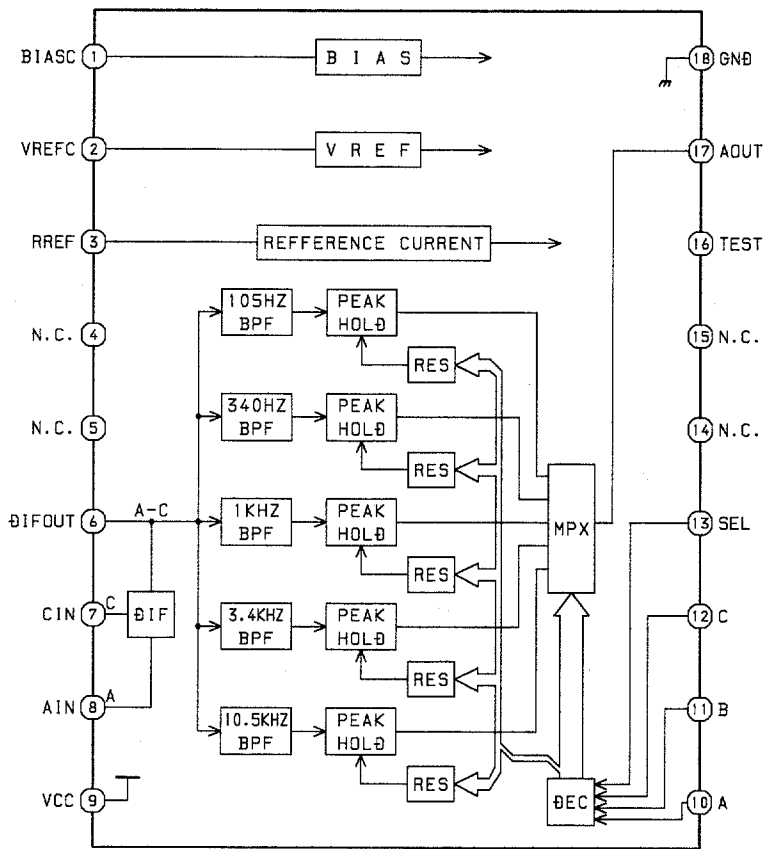

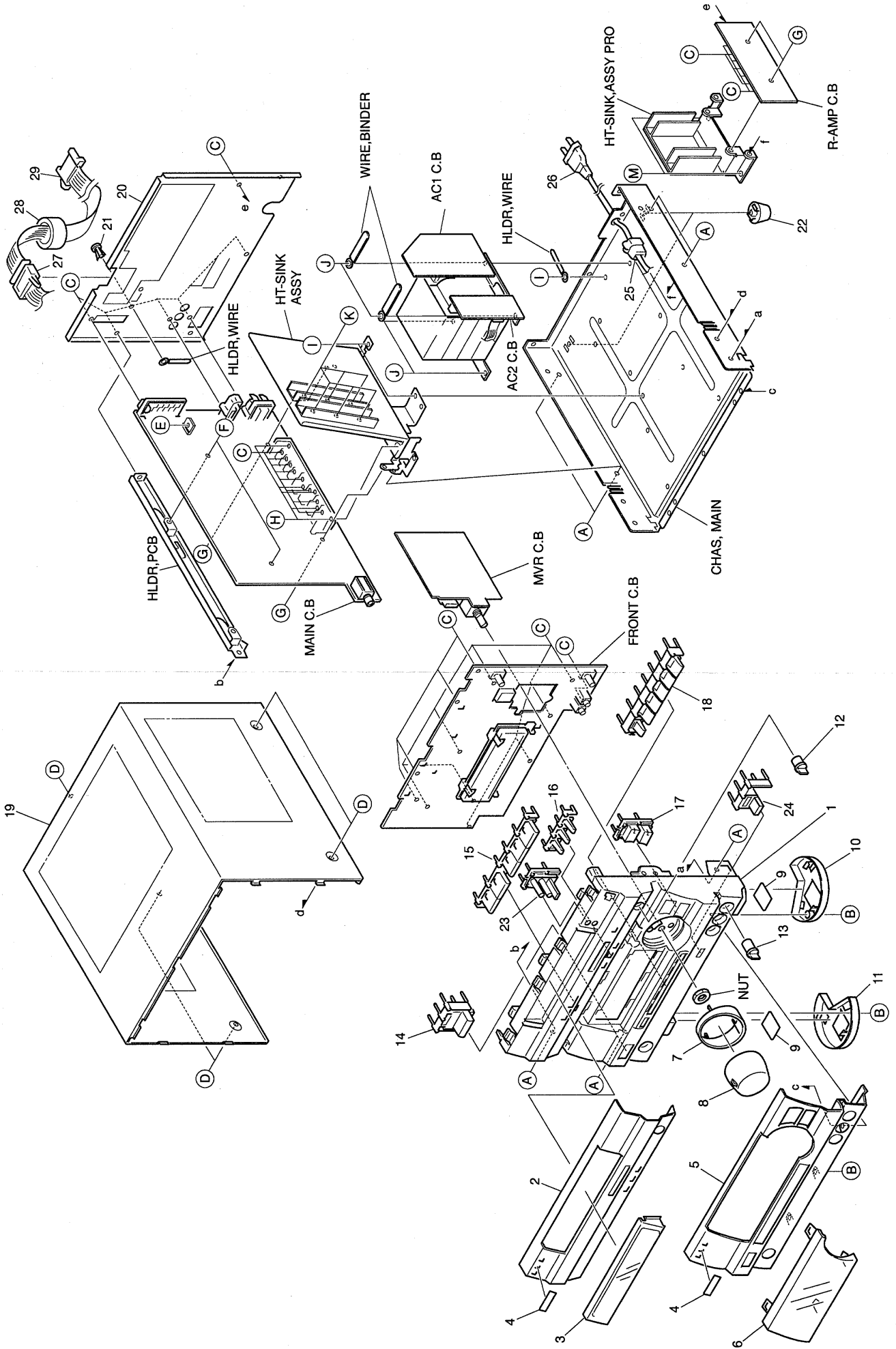

MECHANICAL PARTS LIST 1 / 1

If can't understand for Description please kindly refer to "REFERENCE NAME LIST".

REF. NO.	PART NO.	KANRI NO.	DESCRIPTION	REF. NO.	PART NO.	KANRI NO.	DESCRIPTION
1	87-NT2-001-010		CABI,FR 2	23	87-NT1-009-010		KEY,TUNING<EZ>
2	87-NTN-012-010		PANEL,FR GEQ 22<K>	24	87-NT2-007-010		KEY,VF
2	87-NTN-013-010		PANEL,FR GEQ 22 E<EZ>	25	87-085-185-010		BUSHING, AC CORD (E)
3	87-NT1-019-010		WINDOW,GEQ	26	87-A80-007-110		AC CORD ASSY,K BLK<K>
4	87-B00-002-010		BADGE,AIWA 30 ABS SIL	26	87-050-079-010		AC-CORD ASSY,E<EZ>
5	87-NTN-011-010		PANEL,FR AMP 22	27	89-VT5-202-010		BUSHING, CORD
6	87-NT1-020-010		WINDOW,DISPLAY<K>	28	87-003-317-010		F-BEAD,FOH2515-LG7
6	87-NT1-036-010		WINDOW,DISPLAY RDS<EZ>	29	84-NF1-650-010		CONN ASSY,3P(S-M)
7	87-NT1-034-010		RING,VOL	A	87-591-095-410		QT2+3-8
8	87-NT1-021-010		KNOB,RTRY VOL	B	87-067-777-010		BVTT+3-6 W,CONVEX BL
9	80-VT1-202-010		FELT,12.5-15.5-2	C	87-067-703-010		TAPPING SCREW, BVT2+3-10
10	87-NT1-035-010		RING,FOOT R	D	87-067-641-010		UTT2+3-8(W/O SLOT)BL
11	87-NT1-015-010		RING,FOOT L	E	87-067-579-010		BVT2+3-8 W/O SLOT
12	87-NT1-024-010		KNOB,RTRY ECHO	F	87-078-084-010		BVTT+3-6 W,CONVEX
13	87-NT1-023-010		KNOB,RTRY MIC	G	87-NF4-224-010		S-SCREW,IT3B+3-8 CU
14	87-NT2-018-010		KEY,POWER T	H	87-067-758-010		BVT2+3-12 W/O SLOT
15	87-NT2-005-010		KEY,DIRECT	I	87-067-688-010		BVTT+3-6
16	87-NT1-010-010		KEY,SET	J	87-078-019-010		S-SCREW,IT+4-6
17	87-NT1-037-010		KEY,ASSY UP/ DOWN	K	87-B10-090-010		BVIT3B+3-12
18	87-NT1-013-010		KEY,FUN				
19	87-NT1-043-010		CABI,STEEL				
20	87-NTN-007-010		PANEL,REAR EZSNM<EZ>				
20	87-NTN-006-010		PANEL,REAR KSNM<K>				
21	87-084-077-010		NYLON RIVET, 3.5-4.5				
22	87-085-213-010		FOOT,H12.5				

MODEL NO.

FD-NH80

PROTECTION OF EYES FROM LASER BEAM DURING SERVICING

This set employs laser. Therefore, be sure to follow carefully the instructions below when servicing.

WARNING!!

WHEN SERVICING, DO NOT APPROACH THE LASER EXIT WITH THE EYE TOO CLOSELY. IN CASE IT IS NECESSARY TO CONFIRM LASER BEAM EMISSION. BE SURE TO OBSERVE FROM A DISTANCE OF MORE THAN 30cm FROM THE SURFACE OF THE OBJECTIVE LENS ON THE OPTICAL PICK-UP BLOCK.



- Caution: Invisible laser radiation when open and interlocks defeated avoid exposure to beam.
- Advarsel: Usynlig laserstråling ved åbning, når sikkerhedsafbrydere er ude af funktion. Undgå udsættelse for stråling.

VAROITUS!

Laiteen Käyttäminen muulla kuin tässä käyttöohjeessa mainitulla tavalla saattaa altistaa käyt-täjän turvallisuusluokan 1 ylittävälle näkymättömälle lasersäteilylle.

WARNING!

Om apparaten används på annat sätt än vad som specificeras i denna bruksanvisning, kan användaren utsättas för osynlig laserstrålning, som överskrider gränsen för laserklass 1.

CAUTION

Use of controls or adjustments or performance of procedures other than those specified herein may result in hazardous radiation exposure.

ATTENTION

L'utilisation de commandes, réglages ou procédures autres que ceux spécifiés peut entraîner une dangereuse exposition aux radiations.

ADVARSEL!

Usynlig laserstråling ved åbning, når sikkerhedsafbrydere er ude af funktion. Undgå udsættelse for stråling.

This Compact Disc player is classified as a CLASS 1 LASER product.

The CLASS 1 LASER PRODUCT label is located on the rear exterior.

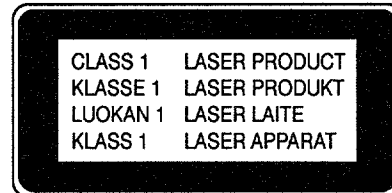

Precaution to replace Optical block

(KSS – 213B)

Body or clothes electrostatic potential could ruin laser diode in the optical block. Be sure ground body and workbench, and use care the clothes do not touch the diode.

- 1) After the connection, remove solder shown in figure right.

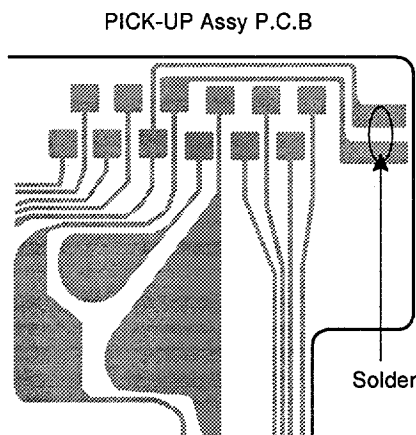

ELECTRICAL MAIN PARTS LIST

If can't understand for Description please kindly refer to "REFERENCE NAME LIST".

REF. NO.	PART NO.	KANRI NO.	DESCRIPTION	REF. NO.	PART NO.	KANRI NO.	DESCRIPTION
IC				C155	87-010-197-080		CAP, CHIP 0.01 DM
				C156	87-010-197-080		CAP, CHIP 0.01 DM
	87-017-022-080		IC, NJM2068M-D(T1)	C157	87-012-156-080		C-CAP, S 220P-50 CH
	87-017-917-080		IC, BU4066BCF	C158	87-012-156-080		C-CAP, S 220P-50 CH
	87-001-607-080		IC, NJM4558M	C159	87-010-318-080		C-CAP, S 47P-50 CH
	87-002-272-080		IC, TC4052BF				
	87-001-894-010		IC, HA12134A	C160	87-010-318-080		C-CAP, S 47P-50 CH
				C181	87-010-805-080		CAP, S 1-16
	87-020-784-080		IC, TC4053BF	C182	87-010-805-080		CAP, S 1-16
	87-017-888-080		IC, NJM4558MD	C183	87-010-197-080		CAP, CHIP 0.01 DM
	87-017-745-010		IC, CXA1782BQ	C184	87-010-318-080		C-CAP, S 47P-50 CH
	87-070-305-010		IC, BA6897S				
	87-001-982-010		IC, TA7291S	C185	87-010-197-080		CAP, CHIP 0.01 DM
				C186	87-010-402-080		CAP, ELECT 2.2-50V
	87-070-294-010		IC, CXD2508AQ	C187	87-010-184-080		CHIP CAPACITOR 3300P(K)
	86-NV1-610-110		IC, LC866424V-5B05	C205	87-010-369-080		C-CAP, S 0.033-25 K B
	87-017-375-080		IC, TC4094BF	C206	87-010-369-080		C-CAP, S 0.033-25 K B
	87-020-454-010		IC, DN6851				
				C303	87-010-183-080		C-CAP, S 2700P-50 B
				C304	87-010-183-080		C-CAP, S 2700P-50 B
TRANSISTOR				C305	87-010-404-080		CAP, ELECT 4.7-50V
	89-503-685-080		C-FET 2SK 368GR	C306	87-010-404-080		CAP, ELECT 4.7-50V
	89-113-625-080		TR, 2SA1362GR(120MHZ, 0.	C323	87-012-157-080		C-CAP, S 330P-50 CH
	89-324-122-080		TR, 2SC2412K	C324	87-012-157-080		C-CAP, S 330P-50 CH
	89-320-011-080		TR, 2SC2001 (15W)	C341	87-010-196-080		CHIP CAPACITOR, 0.1-25
	89-109-521-080		TR, 2SA952 (0.6W)	C342	87-010-196-080		CHIP CAPACITOR, 0.1-25
				C343	87-010-196-080		CHIP CAPACITOR, 0.1-25
	87-026-210-080		CHIP-TR, DTC144EK	C345	87-010-404-080		CAP, ELECT 4.7-50V
	89-110-373-080		CHIP-TR, 2SA1037 S				
	89-318-155-080		TR, 2SC1815 (0.4W)	C346	87-010-404-080		CAP, ELECT 4.7-50V
	89-332-665-080		TR, 2SC3266GR	C347	87-010-404-080		CAP, ELECT 4.7-50V
	87-A30-047-080		TR, CSD655E	C348	87-010-404-080		CAP, ELECT 4.7-50V
				C361	87-010-400-080		CAP, ELECT 0.47-50V
	89-333-266-080		CHIP TR, 2SC3326B	C362	87-010-400-080		CAP, ELECT 0.47-50V
	87-026-233-080		TR, DTA114TK-TP				
	87-026-463-080		TR, 2SA933S (0.3W)	C363	87-010-400-080		CAP, ELECT 0.47-50V
	87-026-211-080		TR, DTA144EK	C364	87-010-400-080		CAP, ELECT 0.47-50V
	87-026-239-080		TR, DTC114TK (0.2W)	C371	87-010-196-080		CHIP CAPACITOR, 0.1-25
				C372	87-010-196-080		CHIP CAPACITOR, 0.1-25
	87-026-609-080		TR, KTA1266GR	C375	87-010-402-080		CAP, ELECT 2.2-50V
	89-421-722-380		TR, 2SD2172V/W				
	87-026-223-080		TR, DTC143TK	C376	87-010-402-080		CAP, ELECT 2.2-50V
	87-026-608-080		C-TR, DTC 123 JK	C377	87-010-247-080		CAP, ELECT 100-50V
	87-A30-039-040		C-TR, 2SD1383K	C378	87-010-401-080		CAP, ELECT 1-50V
				C379	87-010-406-080		CAP, ELECT 22-50
	89-112-965-080		TR, 2SA1296 (0.75W)	C381	87-010-402-080		CAP, ELECT 2.2-50V
	87-A30-067-080		C-TR, 2SA 1298Y				
				C382	87-010-402-080		CAP, ELECT 2.2-50V
DIODE				C401	87-012-156-080		C-CAP, S 220P-50 CH
	87-017-437-080		DIODE, 1N4148M	C402	87-012-156-080		C-CAP, S 220P-50 CH
	87-017-121-080		ZENER, HZS11A1	C403	87-014-059-080		CAP, PP 1200P-100 J
	87-020-123-080		DIODE, DS446 (200MA)	C405	87-010-263-080		CAP, ELECT 100-10V
	87-A40-199-080		ZENER, UZL6H2				
	87-020-331-080		CHIP-DIODE, DAN202K	C409	87-010-402-080		CAP, ELECT 2.2-50V
				C410	87-010-405-080		CAP, ELECT 10-50V
	87-A40-202-080		ZENER, UZ5.1BSB	C411	87-010-178-080		CHIP CAP 1000P
	87-020-339-080		CHIP DIODE, 1SS226	C412	87-010-221-080		CAP, ELECT 470-10V
	87-017-097-080		ZENER, HZS6B1	C414	87-010-196-080		CHIP CAPACITOR, 0.1-25
	87-020-330-080		C-DIODE, DAP202K				
				C451	87-010-237-080		CAP, ELECT 1000-16V
				C452	87-010-101-080		CAP, ELECT 220-16
				C453	87-010-404-080		CAP, ELECT 4.7-50V
				C454	87-010-248-080		CAP, ELECT 220-10V
				C455	87-010-401-080		CAP, ELECT 1-50V
MAIN C.B							
C101	87-012-158-080		C-CAP, S 390P-50 CH	C456	87-010-401-080		CAP, ELECT 1-50V
C102	87-012-158-080		C-CAP, S 390P-50 CH	C457	87-010-263-080		CAP, ELECT 100-10V
C103	87-010-318-080		C-CAP, S 47P-50 CH	C458	87-010-381-080		CAP, ELECT 330-16V
C104	87-010-318-080		C-CAP, S 47P-50 CH	C459	87-010-196-080		CHIP CAPACITOR, 0.1-25
C105	87-010-369-080		C-CAP, S 0.033-25 K B	C481	87-010-406-080		CAP, ELECT 22-50
C106	87-010-369-080		C-CAP, S 0.033-25 K B	C482	87-010-406-080		CAP, ELECT 22-50
C109	87-012-154-080		C-CAP, S 150P-50 CH	C483	87-010-263-080		CAP, ELECT 100-10V
C110	87-012-154-080		C-CAP, S 150P-50 CH	C484	87-010-408-080		CAP, ELECT 47-50V
C111	87-010-197-080		CAP, CHIP 0.01 DM	C485	87-010-221-080		CAP, ELECT 470-10V
C112	87-010-197-080		CAP, CHIP 0.01 DM	C486	87-010-221-080		CAP, ELECT 470-10V
C113	87-010-196-080		CHIP CAPACITOR, 0.1-25	C501	87-010-405-080		CAP, ELECT 10-50V
C151	87-012-156-080		C-CAP, S 220P-50 CH	C502	87-010-198-080		CAP, CHIP 0.022
C152	87-012-156-080		C-CAP, S 220P-50 CH	C503	87-010-196-080		CHIP CAPACITOR, 0.1-25
C153	87-010-322-080		C-CAP, S 100P-50 CH	C504	87-010-196-080		CHIP CAPACITOR, 0.1-25
C154	87-010-322-080		C-CAP, S 100P-50 CH	C505	87-010-196-080		CHIP CAPACITOR, 0.1-25

REF. NO.	PART NO.	KANRI NO.	DESCRIPTION	REF. NO.	PART NO.	KANRI NO.	DESCRIPTION
C506	87-018-209-080		CAP, CER 0.1-50V	C706	87-010-263-080		CAP, ELECT 100-10V
C516	87-010-381-080		CAP, ELECT 330-16V	C707	87-010-197-080		CAP, CHIP 0.01 DM
C517	87-010-404-080		CAP, ELECT 4.7-50V	C708	87-010-400-080		CAP, ELECT 0.47-50V
C518	87-010-404-080		CAP, ELECT 4.7-50V	C709	87-010-197-080		CAP, CHIP 0.01 DM
C519	87-010-405-080		CAP, ELECT 10-50V	C711	87-010-196-080		CHIP CAPACITOR,0.1-25
C520	87-010-405-080		CAP, ELECT 10-50V	C712	87-010-314-080		C-CAP,S 22P-50V
C521	87-012-154-080		C-CAP,S 150P-50 CH	C713	87-010-263-080		CAP, ELECT 100-10V
C522	87-012-154-080		C-CAP,S 150P-50 CH	C714	87-010-197-080		CAP, CHIP 0.01 DM
C523	87-010-405-080		CAP, ELECT 10-50V	C715	87-010-318-080		C-CAP,S 47P-50 CH
C524	87-010-316-080		C-CAP,S 33P-50 CH	C716	87-010-318-080		C-CAP,S 47P-50 CH
C525	87-012-154-080		C-CAP,S 150P-50 CH	C717	87-018-134-080		CAPACITOR,TC-U 0.01-16
C526	87-012-154-080		C-CAP,S 150P-50 CH	C741	87-012-153-080		C-CAP,S 120P-50 CH
C527	87-010-387-080		CAP,E 470-25 SME	C742	87-012-153-080		C-CAP,S 120P-50 CH
C528	87-010-384-080		CAP, ELECT 100-25V	C743	87-010-321-080		CHIP CAPACITOR,82P(J)
C529	87-010-374-080		CAP, ELECT 47-10V	C744	87-010-321-080		CHIP CAPACITOR,82P(J)
C530	87-010-316-080		C-CAP,S 33P-50 CH	C745	87-010-321-080		CHIP CAPACITOR,82P(J)
C531	87-010-316-080		C-CAP,S 33P-50 CH	C746	87-010-321-080		CHIP CAPACITOR,82P(J)
C533	87-012-157-080		C-CAP,S 330P-50 CH	C747	87-012-153-080		C-CAP,S 120P-50 CH
C534	87-012-157-080		C-CAP,S 330P-50 CH	C748	87-012-153-080		C-CAP,S 120P-50 CH
C535	87-012-154-080		C-CAP,S 150P-50 CH	C749	87-012-153-080		C-CAP,S 120P-50 CH
C536	87-012-154-080		C-CAP,S 150P-50 CH	C750	87-012-153-080		C-CAP,S 120P-50 CH
C601	87-010-182-080		C-CAP,S 2200P-50 B	C751	87-010-405-040		CAP,E 10-50
C602	87-010-196-080		CHIP CAPACITOR,0.1-25	C752	87-010-405-040		CAP,E 10-50
C603	87-010-196-080		CHIP CAPACITOR,0.1-25	C753	87-010-186-080		CAP,CHIP 4700P
C604	87-010-196-080		CHIP CAPACITOR,0.1-25	C754	87-010-186-080		CAP,CHIP 4700P
C605	87-010-404-080		CAP, ELECT 4.7-50V	C755	87-010-381-080		CAP, ELECT 330-16V
C606	87-010-193-080		CHIP CAPACITOR,0.033	C756	87-010-263-040		CAP,E 100-10
C607	87-010-197-080		CAP, CHIP 0.01 DM	C771	87-010-322-080		C-CAP,S 100P-50
C608	87-010-402-080		CAP, ELECT 2.2-50V	C772	87-010-322-080		C-CAP,S 100P-50
C609	87-010-265-080		CAP, ELECT 33-16V	C773	87-010-318-080		C-CAP,S 47P-50 CH
C610	87-010-213-080		C-CAP,S 0.015-50 B	C774	87-018-131-080		CAP, CER 1000P-50V
C611	87-010-197-080		CAP, CHIP 0.01 DM	C791	87-010-263-080		CAP, ELECT 100-10V
C612	87-010-263-080		CAP, ELECT 100-10V	C792	87-010-197-080		CAP, CHIP 0.01 DM
C613	87-018-134-080		CAPACITOR,TC-U 0.01-16	C901	87-018-149-080		CAP,TC-U 15P-50 CH
C614	87-010-193-080		CHIP CAPACITOR,0.033	C902	87-012-145-080		CAP, CHIP S 270P CH
C615	87-010-197-080		CAP, CHIP 0.01 DM	C941	87-010-196-080		CHIP CAPACITOR,0.1-25
C616	87-010-193-080		CHIP CAPACITOR,0.033	C942	87-010-196-080		CHIP CAPACITOR,0.1-25
C617	87-010-197-080		CAP, CHIP 0.01 DM	C943	87-010-384-080		CAP, ELECT 100-25V
C618	87-010-146-080		CHIP CAP 2PF	C944	87-010-322-080		C-CAP,S 100P-50 CH
C619	87-010-154-080		CAP CHIP 10P	C945	87-010-322-080		C-CAP,S 100P-50 CH
C620	87-010-263-080		CAP, ELECT 100-10V	C946	87-010-322-080		C-CAP,S 100P-50 CH
C621	87-010-178-080		CHIP CAP 1000P	C947	87-010-322-080		C-CAP,S 100P-50
C622	87-010-198-080		CAP, CHIP 0.022	C948	87-010-322-080		C-CAP,S 100P-50
C623	87-010-196-080		CHIP CAPACITOR,0.1-25	C949	87-010-322-080		C-CAP,S 100P-50
C624	87-010-197-080		CAP, CHIP 0.01 DM	EMI803	87-008-372-080		FILTER, EMI BL OIRNI
C625	87-010-263-080		CAP, ELECT 100-10V	EMI804	87-008-372-080		FILTER, EMI BL OIRNI
C626	87-010-248-080		CAP, ELECT 220-10V	EMI805	87-008-372-080		FILTER, EMI BL OIRNI
C627	87-010-197-080		CAP, CHIP 0.01 DM	EMI807	87-008-372-080		FILTER, EMI BL OIRNI
C628	87-010-260-080		CAP, ELECT 47-25V	FC1	85-NFT-611-110		FF-CABLE 16P-1.0
C629	87-010-196-080		CHIP CAPACITOR,0.1-25	FC2	88-916-301-210		FF-CABLE,16P 1.25
C640	87-010-196-080		CHIP CAPACITOR,0.1-25	FC3	88-909-251-210		FF-CABLE,9P 1.25
C641	87-010-221-080		CAP, ELECT 470-10V	FC4	88-906-201-110		FF-CABLE,6P 1.25
C642	87-010-196-080		CHIP CAPACITOR,0.1-25	FC5	84-ZG1-630-010		CABLE FFC 6P-1.25
C643	87-010-197-080		CAP, CHIP 0.01 DM	FL901	86-NV1-619-010		FL,7-ST-27G
C644	87-010-263-080		CAP, ELECT 100-10V	J901	81-VP1-635-010		JACK,PIN 3P EARTH
C645	87-010-221-080		CAP, ELECT 470-10V	J902	81-VP1-634-010		JACK,PIN 3P
C646	87-010-197-080		CAP, CHIP 0.01 DM	J903	81-VP1-635-010		JACK,PIN 3P EARTH
C647	87-010-196-080		CHIP CAPACITOR,0.1-25	L301	86-NV1-618-010		COIL,TRAP 108K
C648	87-010-196-080		CHIP CAPACITOR,0.1-25	L302	86-NV1-618-010		COIL,TRAP 108K
C649	87-010-193-080		CHIP CAPACITOR,0.033	L303	87-003-131-080		COIL, 10MH
C661	87-010-196-080		CHIP CAPACITOR,0.1-25	L304	87-003-131-080		COIL, 10MH
C662	87-010-260-080		CAP, ELECT 47-25V	L305	87-003-123-080		COIL, 2.2MH
C681	87-010-197-080		CAP, CHIP 0.01 DM	L306	87-003-123-080		COIL, 2.2MH
C692	87-010-381-080		CAP, ELECT 330-16V	L401	86-NV1-617-010		COIL,OSC BIAS 108K
C693	87-010-196-080		CHIP CAPACITOR,0.1-25	L402	87-005-447-080		COIL,180UH FLR50
C701	87-010-194-080		CAP, CHIP 0.047	L451	87-005-474-080		COLL,12UH J FLR50
C702	87-010-188-080		CAP,CHIP 6800P	L601	87-003-102-080		COIL, 10UH
C703	87-010-186-080		CAP,CHIP 4700P	L901	87-A50-052-010		COIL,CLOCK 5.76MHZ T1
C704	87-012-156-080		C-CAP,S 220P-50 CH	L902	87-005-165-080		COIL 1UH (H,E)
C705	87-010-404-080		CAP, ELECT 4.7-50V	LED791	87-A40-123-010		LED,SLZ-8128A-01-B

REF. NO.	PART NO.	KANRI NO.	DESCRIPTION	REF. NO.	PART NO.	KANRI NO.	DESCRIPTION
LED910	87-070-108-010		LED SLF301C-37	CON502	87-099-756-019		CONN, 15P 9604 S F
LED911	87-070-108-010		LED SLF301C-37				
SFR101	87-024-238-080		SFR,1K DIA6 V TP				
SFR102	87-024-238-080		SFR,1K DIA6 V TP	HEAD-1 C.B			
SFR151	87-024-238-080		SFR,1K DIA6 V TP		85-ZM3-602-010		PWB,FLEX A
SFR152	87-024-238-080		SFR,1K DIA6 V TP				
SFR301	87-024-271-080		SFR4.7K DIA6 V	HEAD-2 C.B			
SFR302	87-024-271-080		SFR4.7K DIA6 V				
SFR401	87-024-275-080		SFR 47K DIA6V TP		85-ZM3-602-010		PWB,FLEX A
SFR402	87-024-275-080		SFR 47K DIA6V TP				
SFR601	87-024-175-080		SEMI-FIXED RESISTOR, 47K	T-T C.B			
SFR602	87-024-176-080		SEMI-FIXED RESISTOR, 100K				
SFR603	87-024-176-080		SEMI-FIXED RESISTOR, 100K				
SW731	87-036-109-010		PUSH SWITCH	C401	87-018-214-089		CAP,TC-U 0.1-50 F
SW732	87-036-109-010		PUSH SWITCH	FC401	84-ZG1-614-119		CABLE FFC 5P-1.25
VR501	86-NV1-616-010		VR,RTRY 50KBX2 H RK14K12A0L30	M401	87-045-364-019		MOTOR, (BCH3B14)
VR502	81-MX4-636-010		VR,50KBX2 RK14K12A0	PS401	87-026-573-019		P-SNSR,GPI553V
X701	87-030-270-080		VIB,XTAL 16.9344MHZ				
				DRIVE C.B			
KEY1 C.B				M1	87-045-358-019		MOT,RF-310TA 43
				M2	87-045-356-019		MOT,RF-310TA 30
				SW1	87-A90-042-019		SW,LEAF MSW 17310 MVPO
LED901	87-017-717-010		LED SEL2510C GRN				
LED902	87-017-717-010		LED SEL2510C GRN				
LED903	87-017-717-010		LED SEL2510C GRN				
LED904	87-017-717-010		LED SEL2510C GRN				
LED905	87-017-717-010		LED SEL2510C GRN				
LED906	87-017-717-010		LED SEL2510C GRN				
S901	87-A90-095-080		SW,TACT EVQ11G04M				
S902	87-A90-095-080		SW,TACT EVQ11G04M				
S903	87-A90-095-080		SW,TACT EVQ11G04M				
S904	87-A90-095-080		SW,TACT EVQ11G04M				
S905	87-A90-095-080		SW,TACT EVQ11G04M				
S906	87-A90-095-080		SW,TACT EVQ11G04M				
S907	87-A90-095-080		SW,TACT EVQ11G04M				
S908	87-A90-095-080		SW,TACT EVQ11G04M				
S909	87-A90-095-080		SW,TACT EVQ11G04M				
S910	87-A90-095-080		SW,TACT EVQ11G04M				
KEY2 C.B							
LED907	87-A40-317-080		LED,SLR-342VCT31 RED				
LED908	87-A40-317-080		LED,SLR-342VCT31 RED				
LED909	87-A40-317-080		LED,SLR-342VCT31 RED				
S912	87-A90-095-080		SW,TACT EVQ11G04M				
S913	87-A90-095-080		SW,TACT EVQ11G04M				
S914	87-A90-095-080		SW,TACT EVQ11G04M				
S915	87-A90-095-080		SW,TACT EVQ11G04M				
S916	87-A90-095-080		SW,TACT EVQ11G04M				
LED C.B							
LED701	87-A40-268-080		LED,SLH-56DCT31 ORN				
LED702	87-A40-316-080		LED,SLR-56PCT31 GRN				
LED703	87-A40-316-080		LED,SLR-56PCT31 GRN				
LED704	87-A40-268-080		LED,SLH-56DCT31 ORN				
DECK C.B							
W001	82-ZM3-601-019		RBN,CORD,4P-75				
SFR1	87-024-581-019		SFR,3.3K DIA 6H				
SOL1	82-ZM1-618-010		SOL ASSY, 27				
SOL2	82-ZM1-618-010		SOL ASSY, 27				
SW1	87-A90-248-019		SW,MICRO ESE11SH2CXQ				
SW2	87-A90-248-019		SW,MICRO ESE11SH2CXQ				
SW3	87-A90-248-019		SW,MICRO ESE11SH2CXQ				
SW4	87-036-110-010		SW,MICRO SPPB62				
SW5	87-036-110-010		SW,MICRO SPPB62				
SW6	87-036-110-010		SW,MICRO SPPB62				
SW8	87-A90-248-019		SW,MICRO ESE11SH2CXQ				
SW9	87-036-110-010		SW,MICRO SPPB62				

○ チップ抵抗部品コード / CHIP RESISTOR PART CODE

チップ抵抗部品コードの成り立ち
Chip Resistor Part Coding

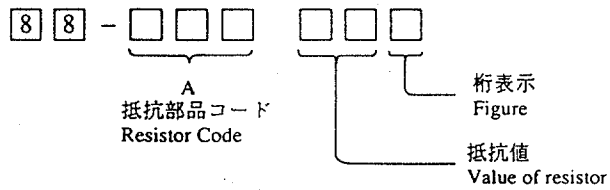

チップ抵抗
Chip resistor

容量 Wattage	種類 Type	許容誤差 Tolerance	記号 Symbol	寸法 / Dimensions (mm)			抵抗コード : A Resistor Code: A	
				外形 / Form	L	W		t
1/16W	1608	±5%	CJ		1.6	0.8	0.45	108
1/10W	2125	±5%	CJ		2	1.25	0.45	118
1/8W	3216	±5%	CJ		3.2	1.6	0.55	128

TRANSISTOR ILLUSTRATION



E C B

2SC1815
2SC3266
KTA1266GR
2SA1296



E C B

2SC2001
2SA952
CSD655E



E C B

2SA933S

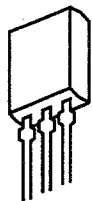

E C B

2SD2172

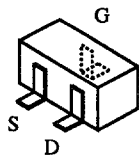

2SK368GR

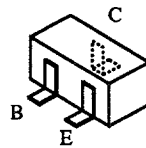

2SA1362GR DTA144EK
SC2412KR DTC114TK
DTC144EK DTC143TK
2SA1037S DTC123JK
2SC3326 2SD1383
DTA114TK 2SA1298

BLOCK DIAGRAM

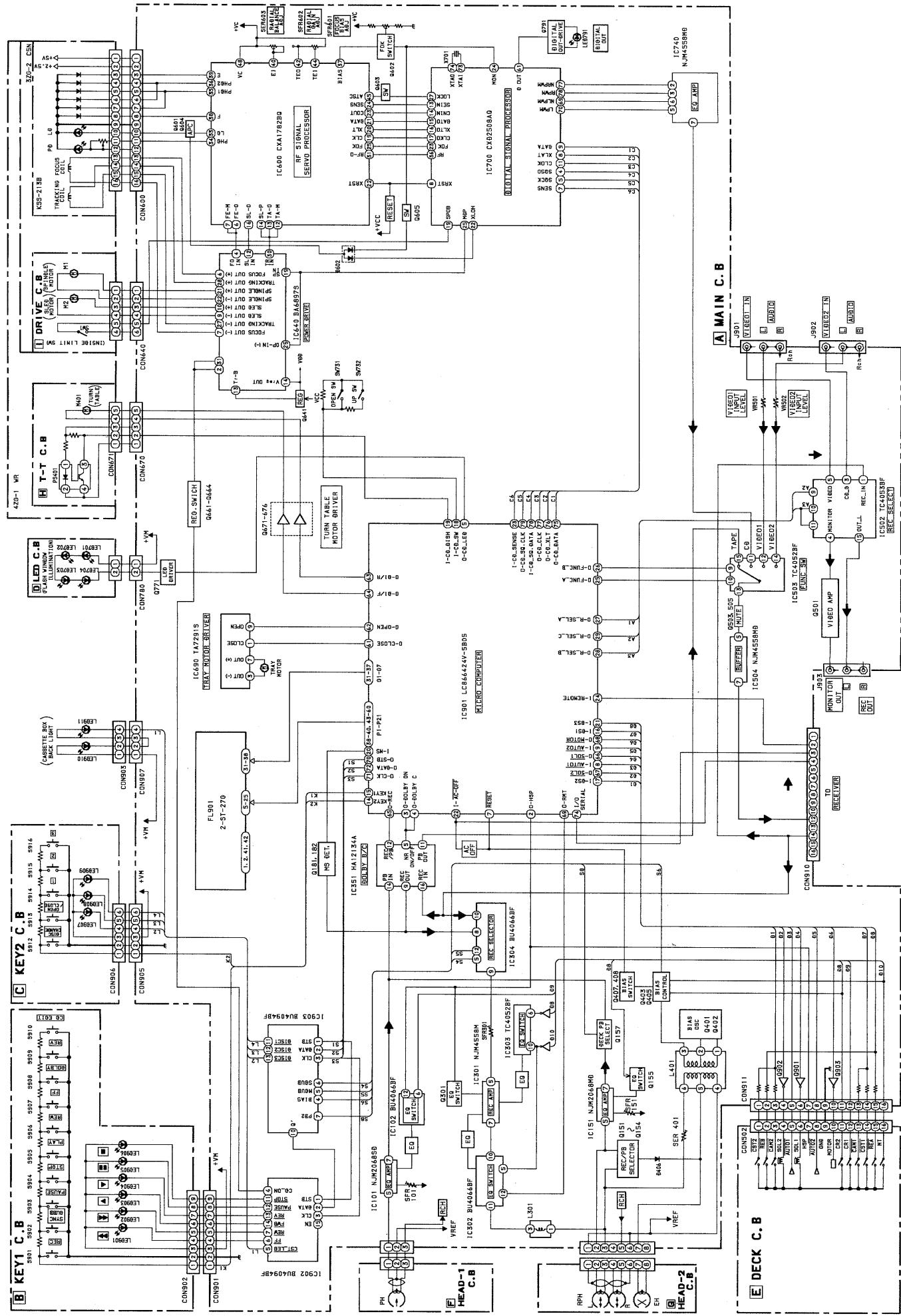

1 2 3 4 5 6 7 8 9 10 11 12 13 14

A

B

C

D

E

F

G

H

I

J

A MAIN C.B

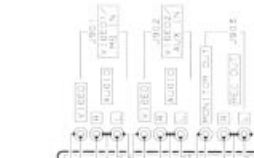
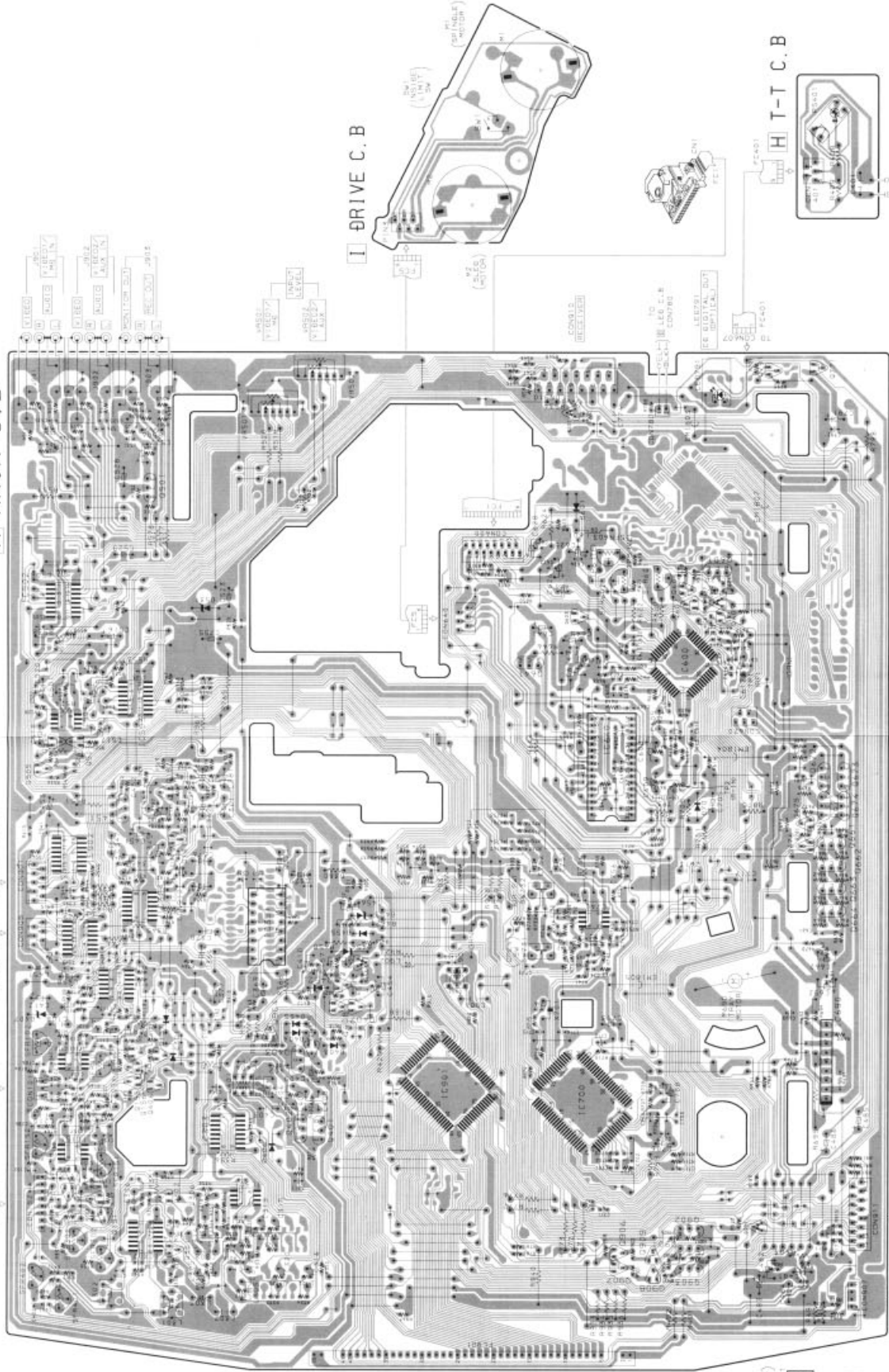

I DRIVE C.B

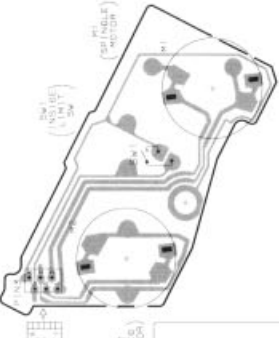

H T-T C.B

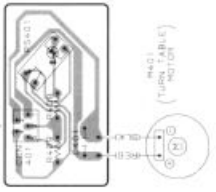

1 2 3 4 5 6 7 8 9 10 11 12 13 14

A B C D E F G H I J K L M N O P Q R S T U V W X Y Z

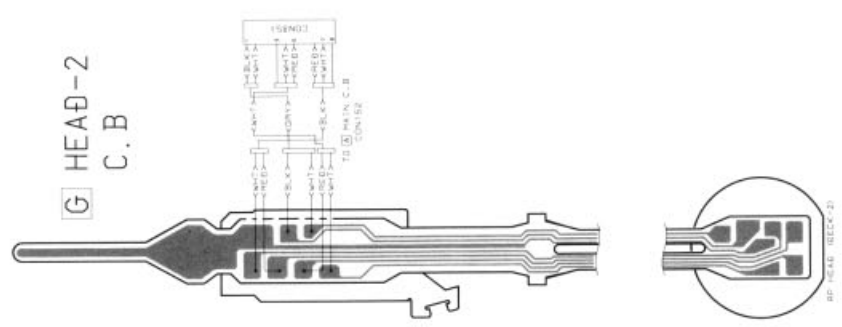
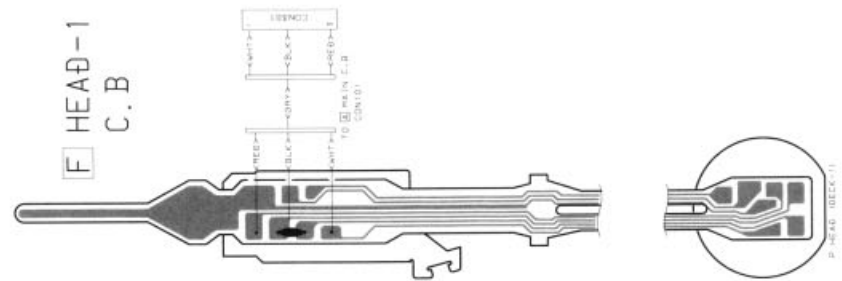
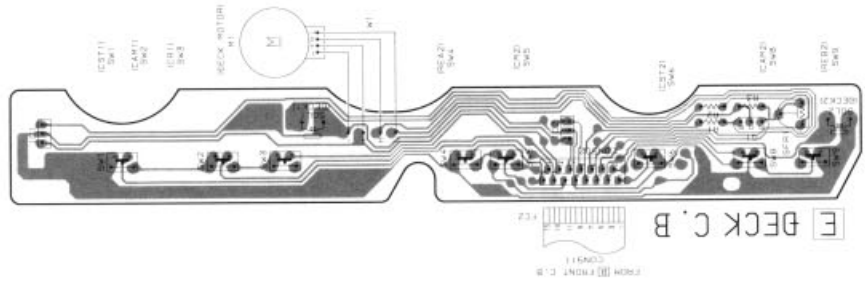
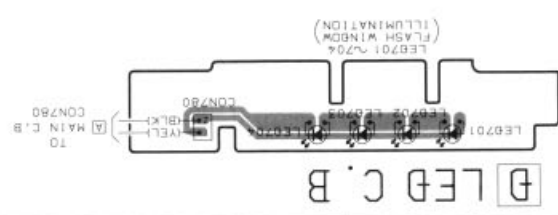
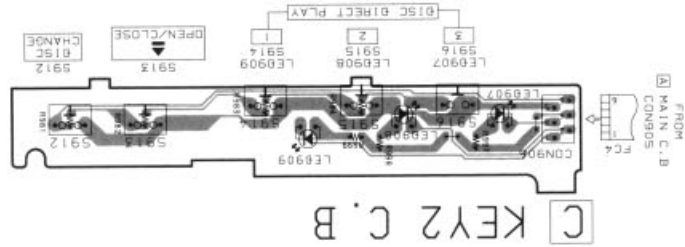
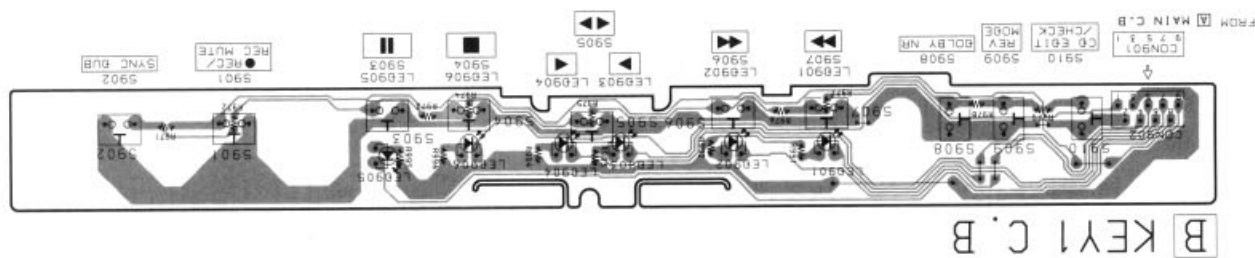

FL GRID ASSIGNMENT AND ANODE CONNECTION

FL, 7-ST-27G

GRID ASSIGNMENT

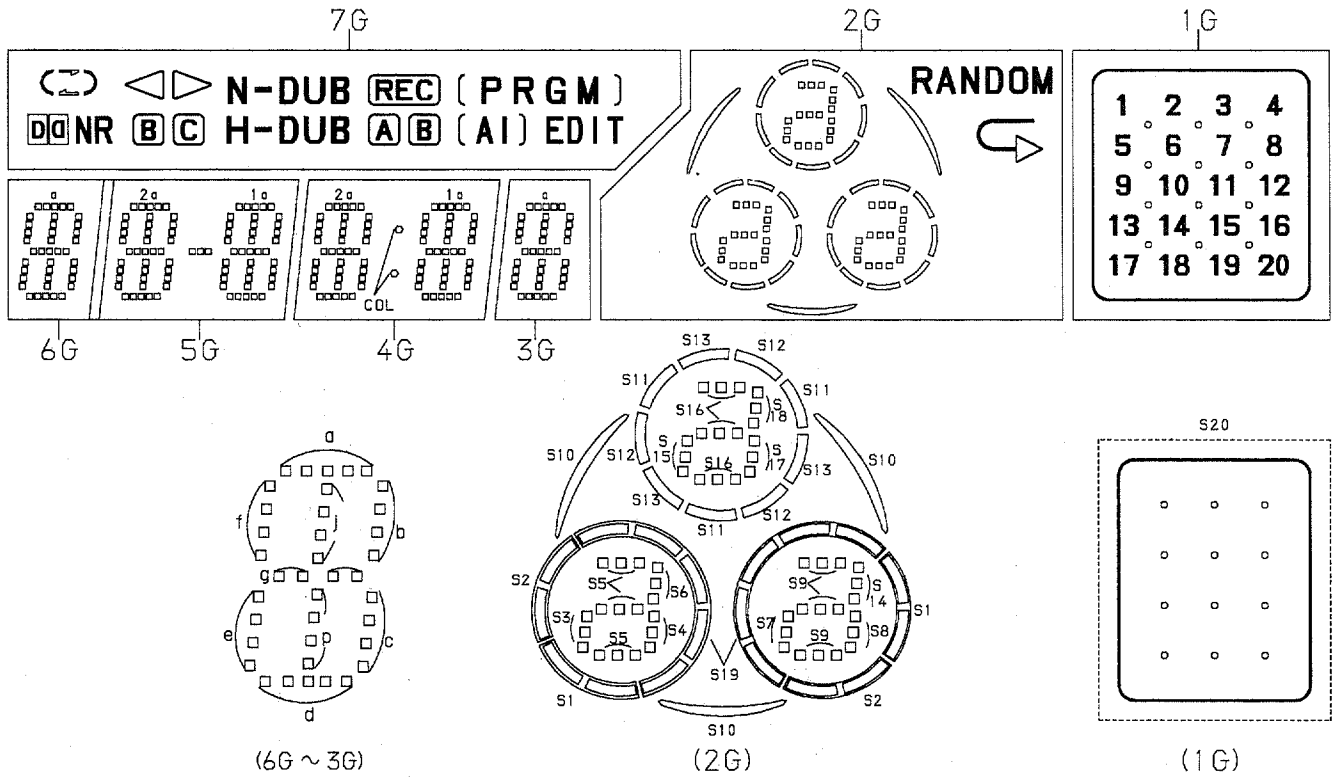

ANODE CONNECTION

	7G	6G	5G	4G	3G	2G	1G
P1	<input checked="" type="checkbox"/> NR	d	1d	1d	d	S1	20
P2	<input checked="" type="checkbox"/>	p	1p	1p	p	S2	19
P3	<input checked="" type="checkbox"/>	e	1e	1e	e	S3	18
P4	<input checked="" type="checkbox"/>	c	1c	1c	c	S4	17
P5	<input checked="" type="checkbox"/> (LEFT)	q	1q	1q	q	S5	16
P6	<input checked="" type="checkbox"/> C	f	1f	1f	f	S6	15
P7	<input checked="" type="checkbox"/>	b	1b	1b	b	S7	14
P8	<input checked="" type="checkbox"/>	j	1j	1j	j	S8	13
P9	N-DUB	a	1a	1a	a	S9	12
P10	H-DUB	—	2d	2d	—	S10	11
P11	REC	—	2p	2p	—	S11	10
P12	A	—	2e	2e	—	S12	9
P13	<input checked="" type="checkbox"/> (RIGHT)	—	2c	2c	—	S13	8
P14	PRGM	—	2g	2g	—	S14	7
P15	AI	—	2f	2f	—	S15	6
P16	EDIT	—	2b	2b	—	S16	5
P17	(PRGM)	—	2j	2j	—	S17	4
P18	(AI)	—	2a	2a	—	S18	3
P19	—	—	COL	COL (HIGH)	—	S19	2
P20	—	—	—	COL (LOW)	—	<input checked="" type="checkbox"/>	1
P21	—	—	—	—	—	RANDOM	S20

IC DESCRIPTION

IC, LC866424V-5B05

Pin No.	Pin Name	I/O	Description															
1	O-BEAT	O	REC beat output. (ON/ $\overline{\text{OFF}}$)															
2	O-HSP	O	High speed dubbing switch. (HIGH/ $\overline{\text{NORMAL}}$)															
3	O-DOLBY/ON	O	DOLBY IC switch output. (DOLBY ON/ $\overline{\text{OFF}}$)															
4	O-DOLBY/C	O	DOLBY IC mode switch output. (DOLBY $\overline{\text{B/C}}$)															
5	O-CD/LED	O	Flash window output. (ON/ $\overline{\text{OFF}}$)															
6	O-SHIFT	O	Microprocessor clock shift out during tuner reception.															
7	$\overline{\text{RESET}}$	I	Reset input (Reset at 'L').															
8	$\overline{\text{I-AUTO 1}}$	I	Deck 1 auto stop input.															
9	$\overline{\text{I-AUTO 2}}$	I	Deck 2 auto stop input.															
10	VSS 1	-	GND.															
11	CF 1	I	5.76 MHz oscillator.															
12	CF 2	O	5.76 MHz oscillator.															
13	VDD 1	-	Power supply input.															
14	I-KEY 1	I	Key 1 A/D input.															
15	I-KEY 2	I	Key 2 A/D input.															
16	I-DS 1	I	Deck 1 mechanism switch input.															
17	I-DS 2	I	Deck 2 mechanism switch input.															
18	$\overline{\text{I-CD/SW}}$	I	CD mechanism switch A/D input.															
19	$\overline{\text{I-CD/DISH}}$	I	CD turntable photo sensor A/D input.															
20	I-MS	I	Deck MS detection A/D input.															
21	$\overline{\text{I-DS 3}}$	I	Deck mechanism switch input (REC enable A/D input).															
22	$\overline{\text{I-AC/OFF}}$	I	HOLD input.															
23	$\overline{\text{I-CD/SENSE}}$	I	CD microprocessor control SENSE input.															
24	I-TYPE	I	TYPE select A/D input. (H : DOLBY C / L : DOLBY B)															
25~26	O-FUNC/A~B	O	FUNCTION switch output. <table border="1" style="display: inline-table; vertical-align: middle;"> <thead> <tr> <th></th> <th>AUX1</th> <th>AUX2</th> <th>TAPE</th> <th>CD</th> </tr> </thead> <tbody> <tr> <td>A</td> <td>0</td> <td>1</td> <td>0</td> <td>1</td> </tr> <tr> <td>B</td> <td>0</td> <td>0</td> <td>1</td> <td>1</td> </tr> </tbody> </table>		AUX1	AUX2	TAPE	CD	A	0	1	0	1	B	0	0	1	1
	AUX1	AUX2	TAPE	CD														
A	0	1	0	1														
B	0	0	1	1														
27	O-R-SEL/A	O	Video signal switch. (VIDEO 1/2)															
28	O-R-SEL/B	O	REC output switch. (ON/ $\overline{\text{MUTE}}$)															
29	O-R-SEL/C	O	Monitor output switch. ($\overline{\text{VIDEO/CDG}}$)															
30	-	-	Not used.															
31~37	G7~G1	O	FL grid output (G7~G1).															
38~40	P21~P19	O	FL segment output P21~P19.															
41	VDD2	-	Power supply input.															
42	-VP	-	Power supply for FL display .															
43~60	P18~P8	O	FL segment output P18~P8.															
61	O-CLOSE	O	CD tray close data output.															
62	O-OPEN	O	CD tray open data output.															
63	O-DI/R	O	CD turntable reverse rotation output.															
64	O-DI/F	O	CD turntable forward rotation output.															
65	O-REC	O	Deck REC switch output.															
66	O-SOL1	O	Deck 1 plunger $\overline{\text{ON/OFF}}$ output.															

67	O-SOL2	O	Deck 2 plunger $\overline{\text{ON}}$ /OFF output.
68	O-MOTOR	O	Deck motor $\overline{\text{ON}}$ /OFF output.
69	O-RMT	O	REC mute $\overline{\text{ON}}$ /OFF output.
70	O-STB	O	Front shift register, data latch strobe output.
71	O-CLK	O	Front shift register, data transfer clock output.
72	O-DATA	O	Front shift register, data output.
73	VSS2	-	GND.
74	I/O/SERIAL	I/O	Command input / output with the CD microprocessor.
75	O-CD/DATA	O	CD microprocessor control data output.
76	O-CD/XLT	O	CD microprocessor control latch output.
77	O-CD/CLK	O	CD microprocessor control clock output.
78	I-CD/SQ,DATA	I	CD SUB-Q data input.
79	O-CD/SQ,DATA	O	CD SUB-Q clock output.
80	O-MUTE	O	System mute $\overline{\text{ON}}$ /OFF output.

IC, CXD2508AQ

Pin No.	Pin Name	I/O	Description
1	SCOR	O	1H when the subcode sync S0 or S1 is detected.
2	SBSO	O	SUBP ~ W serial output.
3	EXCK	I	Clock input for SBSO read out.
4	SQSO	O	SUBQ 80-bit serial output.
5	SQCK	I	Clock input for SQSO read out.
6	MUTE	I	H to mute. L to cancel. (Connected to GND)
7	SENS	O	SENS signal output to MAIN CPU.
8	XRST	I	System reset. L to reset.
9	DATA	I	Serial data input from MAIN CPU.
10	XLAT	I	Latch input from MAIN CPU. Latching serial data at fall down.
11	CLOK	I	Clock input from MAIN CPU to transfer serial data.
12	VSS	-	GND.
13	SEIN	I	SENS input from SSP.
14	CNIN	I	Numbers of track jump are counted and input.
15	DATO	O	Serial data output to SSP.
16	XLTO	O	Serial data latched output to SSP. Latched at fall down edge.
17	CLKO	O	Clock input from SSP to transfer serial data.
18	TEST2	I	TEST. (Connected to +5V)
19~21	SPOB~D	I	Input from INSIDE LIMIT switch (SW1).
22	XLON	O	Mute control output.
23	FOK	I	Focus OK input pin. Used for SENS output and servo auto sequencer.
24	MON	O	Spindle motor ON/OFF control output.
25	MDP	O	Spindle motor servo control output.
26	MDS	O	Spindle motor servo control output.
27	LOCK	O	GFS is sampled by 460Hz. H output when GFS is H. L output when GFS is L for 8 consecutive times.
18	TEST1	I	TEST. (Connected to GND)
19	FILO	O	Filter output to master PLL. (Slave = digital PLL)
30	FILI	I	Filter input to master PLL.
31	PCO	O	Charge-pump output to master PLL.
32	VDD	-	Power supply input. (+5V)
33	AVSS1	-	GND.
34	CLTV	I	VCO control voltage input to master PLL.
35	AVDD1	-	Power supply input. (+5V)
36	RF	I	EFM signal input.
37	BIAS	I	Constant current input to asymmetry correction circuit.
38	ASYI	I	Comparator voltage input to asymmetry correction circuit.
39	ASYO	O	EFM full swing output. (L = VSS, H = VDD)
40	ASYE	I	L: asymmetry correction OFF. H: asymmetry correction ON. (Connected to +5V)
41	WCDK	O	D/A interface, word clock (2Fs) for 48-bit slot.

Pin No.	Pin Name	I/O	Description
42	LRCK	O	D/A interface, LR clock (FS) for 48-bit slot.
43	LRCKI	I	LR clock input to DAC. (48-bit slot)
44	PCMD	O	D/A interface, serial data. (2's complement, MSB first)
45	PCMDI	I	Audio data input to DAC. (48-bit slot)
46	BCK	O	D/A interface, bit clock.
47	BCK1	I	Bit clock input to DAC. (48-bit slot)
48	GTOP	O	GTOP output.
49	XUGF	O	XUGF output.
50	XPCK	O	XPLCK output.
51	GFS	O	GFS output.
52	RFCK	O	RFCK output.
53	VSS	-	GND.
54	C2PO	O	C2PO output.
55	XROF	O	XRAOF output.
56	MNT3	O	MNT3 output.
57	MNT1	O	MNT1 output.
58	MNT0	O	MNT0 output.
59	FSTT	O	Pins-73 and -74 divided-by 2/3 output.
60	C4M	O	4.2336MHz output.
61	DOUT	O	Digital Out connector output signal.
62	EMPH	O	H when the play back disk has emphasis. L when it does not.
63	EMPHI	I	DAC emphasis ON/OFF. H when ON. L when OFF.
64	WFCK	O	WFCK (WRITE FRAME CLOCK) output.
65	ZEROL	O	Not sound data detection output. H (L-ch) when no sound data is detected.
66	ZEROR	O	Not sound data detection output. H (L-ch) when no sound data is detected.
67	DTSI	I	TEST for DAC. (Connected to GND)
68	VDD	-	Power supply input. (+5V)
69	NLPWM	O	L-ch PWM output. (Reversed polarity)
70	LPWM	O	L-ch PWM output. (Normal polarity)
71	AVDD2	-	Power supply input to L-ch PWM driver. (Connected to +5V)
72	AVDD3	-	Power supply input to X'tal. (Connected to +5V)
73	XTAI	I	X'tal input to 33.8688MHz oscillator circuit.
74	XTAO	O	33.8688MHz X'tal oscillator circuit output.
75	AVSS1	-	Power supply input to X'tal. (Connected to GND)
76	AVSS2	-	Power supply input to PWM driver. (Connected to GND)
77	NRPWM	O	R-ch PWM output. (Reversed phase)
78	RPWM	O	R-ch PWM output. (Normal phase)
79	DTS2	I	TEST-2 for DAC. (Connected to GND)
80	DTS3	I	TEST-3 for DAC. (Connected to GND)

IC, CXA1782BQ

Pin No.	Pin Name	I/O	Description
1	FEO	O	Focus error amplifier output pin. This pin is connected to the FZC comparator input internally.
2	FEI	I	Focus error input pin.
3	FDFACT	I	Capacitor connection pin for time constant used when there is defect.
4	FGD	I	This pin is connected to GND via capacitor when high frequency gain of the focus servo is attenuated.
5	FLB	I	This is a pin where the time constant is externally connected to raise the low frequency gain of the focus servo.
6	FEO	O	Focus drive output.
7	FEM	I	Focus amplifier inverted input pin.
8	SRCH	I	This is a pin where the time constant is externally connected to generate the focus search waveform.
9	TGU	I	This is a pin where the selection time constant is externally connected to set the tracking servo the high frequency gain.
10	TG2	I	This is a pin where the selection time constant is externally connected to set the tracking high frequency gain.
11	FSET	I	Pin for setting peak of the phase compensator of the focus tracking.
12	TAM	I	Tracking amplifier inverted input pin.
13	TAO	O	Tracking drive output.
14	SLP	I	Sled amplifier non-inverted input pin.
15	SLM	I	Sled amplifier inverted input pin.
16	SLO	O	Sled drive output.
17	ISET	I	The current which determines height of the focus search, track jump and sled kick is input.
18	VCC	—	+ 5 V power supply pin.
19	CLK	I	Serial data transfer clock input from CPU.
20	XLT	I	Latch input from CPU.
21	DATA	I	Serial data input from CPU.
22	XRST	I	Reset input pin. Reset at L.
23	COUT	O	Signal output to count the number of tracks.
24	SENS	O	FZC, DFCT, TZC, Gain or BAL is output depending on the command from CPU.
25	FOK	O	Output pin of the focus OK comparator.
26	CC2	O	Input pin where the DEFECT bottom hold output is capacitance coupled.
27	CC1	I	DEFECT bottom hold output pin.
28	CB	I	This is a pin where the DEFECT bottom hold capacitor is connected.
29	CP	I	This is a pin where the MIRR hold capacitor is connected and MIRR comparator non-inverted signal is input.
30	RFI	I	Input pin where the RF summing amplifier output is capacitance coupled.
31	RFO	O	RF summing amplifier output pin. (Eye pattern check point)
32	RFM	I	RF summing amplifier inverted input pin. Gain of RF amplifier is determined by the resistor connected between RFO and this pin.

Pin No.	Pin Name	I/O	Description
33	LD	O	APC amplifier output pin.
34	PHD	I	APC amplifier input pin.
35-36	PHD1~2	I	RF I-V amplifier inverted input pin. These pins are connected to the A+C and B+D pins of the optical pickup.
37	FE BIAS	I	Bias adjustment pin of the focus error amplifier.
38-39	F-E	I	F and E IV amplifier non-inverted input pins. These pins are connected to the F and E of the optical pickup.
40	EI	—	Gain adjustment pin of the I-V amplifier E.
41	VEE	—	GND connection pin
42	TEO	O	Tracking error amplifier output pin. E-F signal is output.
43	LPFI	I	BAL adjustment comparator input pin.
44	TEI	I	Tracking error input pin.
45	ATSC	I	Window comparator input pin for detecting ATSC.
46	TZC	I	Tracking zero-cross comparator input pin.
47	TDFCT	I	Capacitor connection pin for the time constant used when there is defect.
48	VC	O	DC voltage output pin of VREF. (VDD/2)

IC BLOCK DIAGRAM

IC, TC4052BF

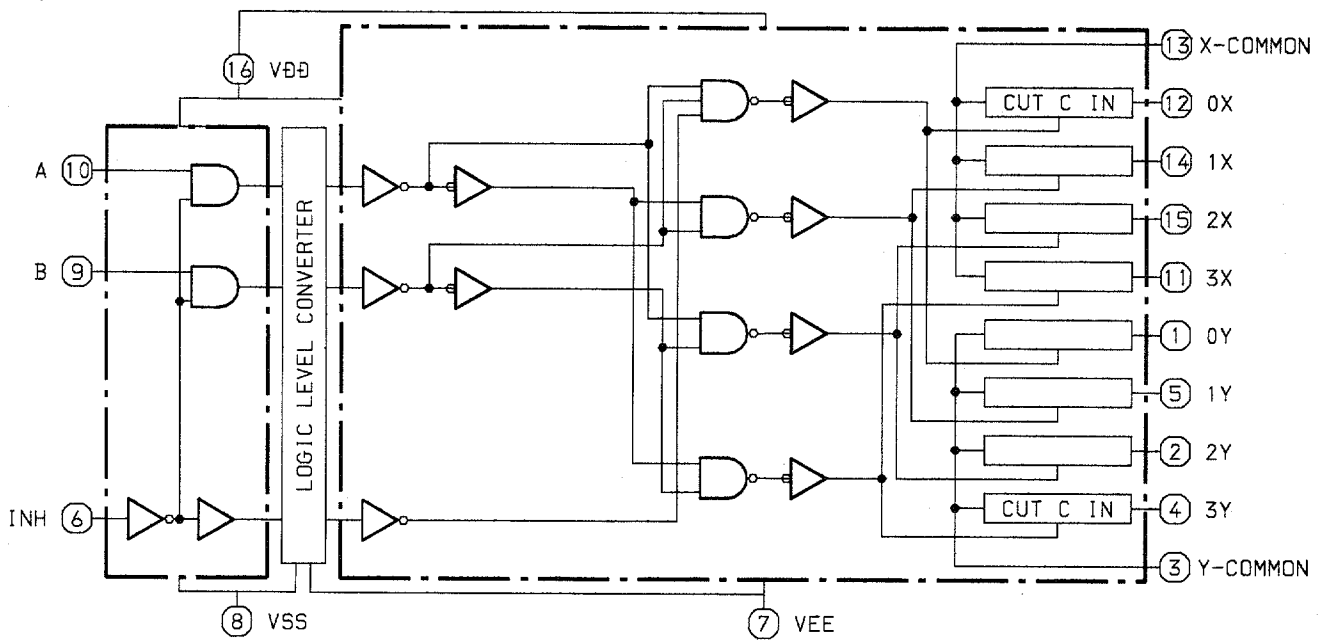

CONTROL INPUTS			
INHIBIT	C \triangle	B	A
L	L	L	L
L	L	L	H
L	L	H	L
L	L	H	H
L	H	L	L
L	H	L	H
L	H	H	L
L	H	H	H
H	*	*	*

*: DON'T CARE \triangle Expect TC4052B

IC, BA6897S

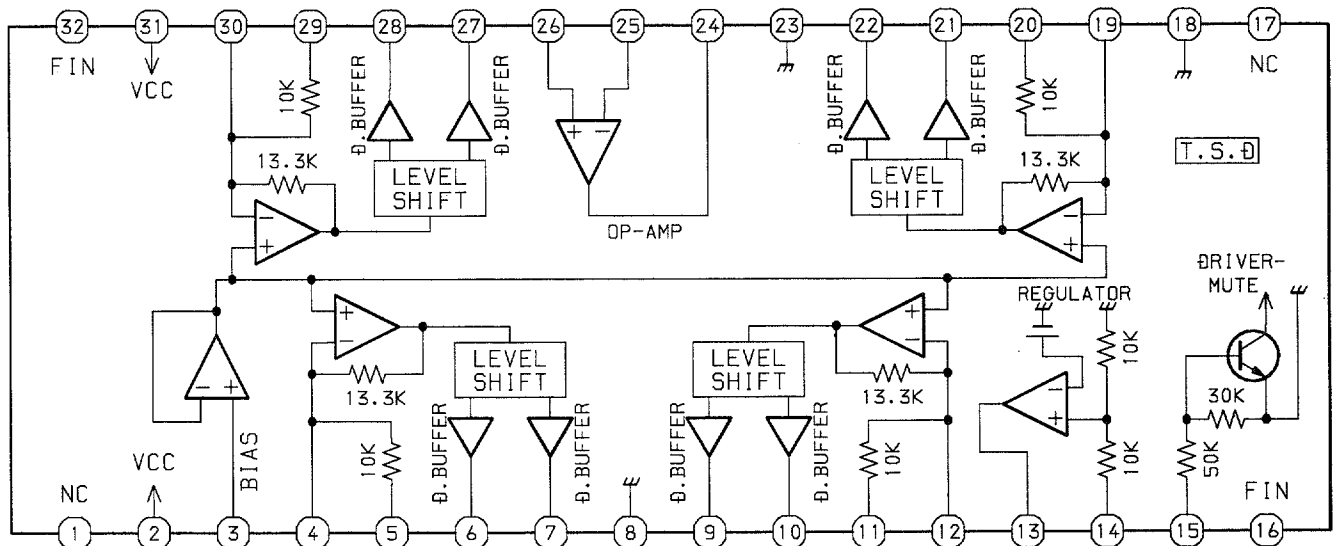

T.S.D: THERMAL SHUT DOWN CIRCUIT
 D.BUFFER: DRIVE BUFFER

IC, TA7291S

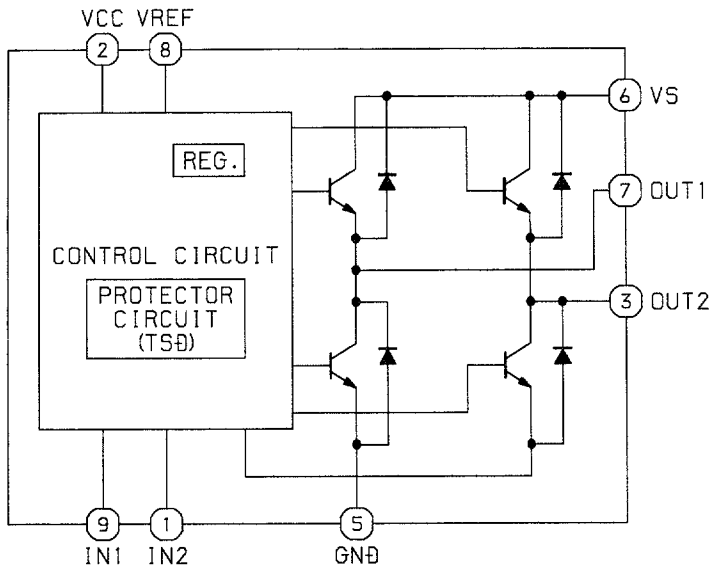

IC, TC4094BF

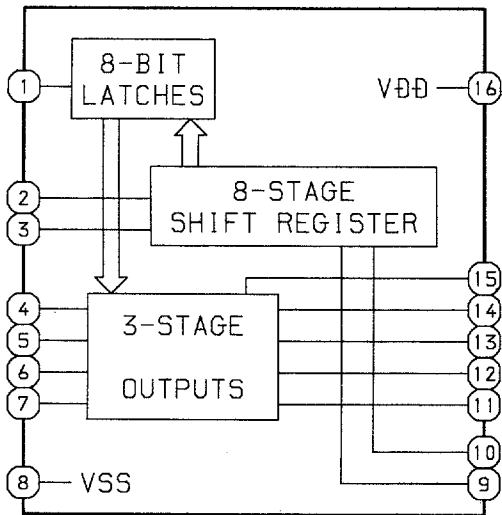

IC, HA12134A

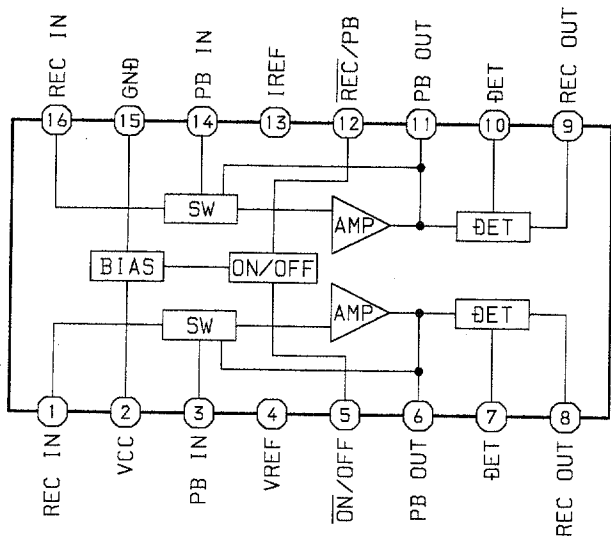

IC, TC4053BF

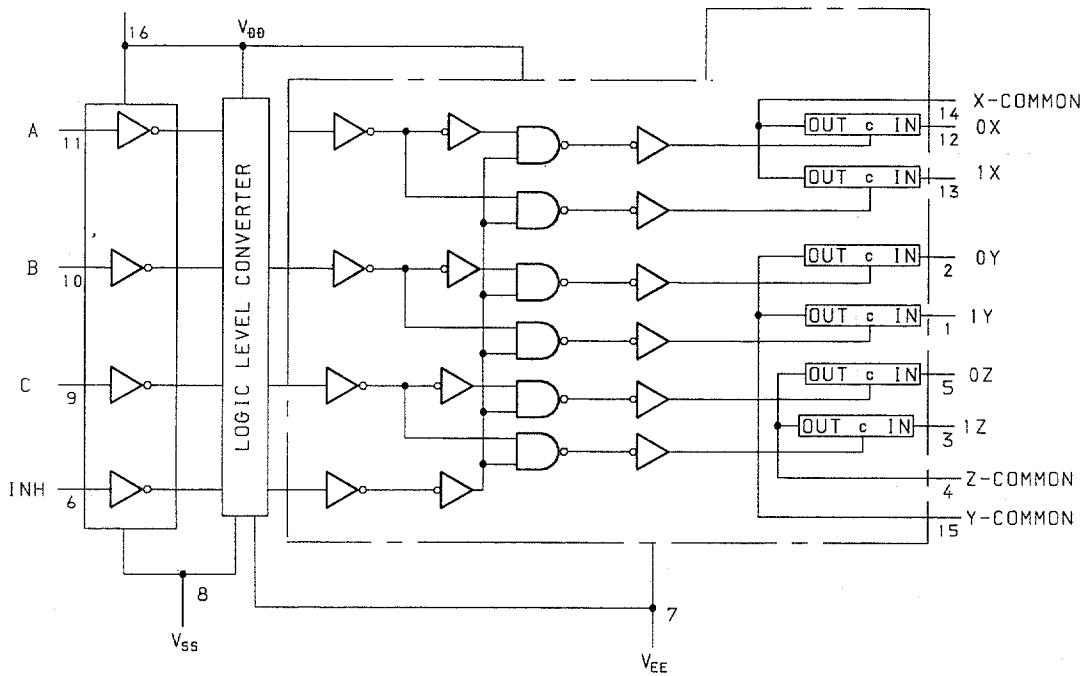

CONTROL INPUTS			
INHIBIT	C Δ	B	A
L	L	L	L
L	L	L	H
L	L	H	L
L	L	H	H
L	H	L	L
L	H	L	H
L	H	H	L
L	H	H	H
H	※	※	※

※:DON't Care Δ Expect TC4052B

TEST MODE

1. How to Activate CD Test Mode

Insert the AC plug while pressing the CD EDIT/CHECK/ button. All FL display tubes will light up, and the test mode will be activated.

2. How to cancel CD Test Mode

Either one of the following operations will cancel the CD test mode.

- Press the power switch button.
- Disconnect the AC plug.

3. CD Test Mode Functions

When test mode is activated, the following mode functions can be used by pressing the operation keys.

Mode	Operation	FL display	Operation	Contents
Start mode	Test mode activation	All FL light up	<ul style="list-style-type: none"> • Laser diode illuminated under normal circumstances (CD block power supply ON) 	Displays the machine mode that it is a test mode. All FL displays light up
Search mode	■ key	- - -	<ul style="list-style-type: none"> • Continual focus search * NOTE 1 (The pickup lens repeats the full-swing up-down motion.) * Avoid continual searches that last for more than 10 minutes. 	FOCUS SERVO <ul style="list-style-type: none"> • Laser current measurement (Across R628 resistor) • Check focus search waveform • Check focus error waveform * FOK / FZC are not monitored in the search mode.
Play mode	▶ key	/ -	<ul style="list-style-type: none"> • Normal playback • Focus search is continued if TOC cannot be read * NOTE 1 	FOCUS SERVO / TRACKING SERVO CLV SERVO / SLED SERVO Check FOK / FZC
Traverse mode	key	/ -	<ul style="list-style-type: none"> • During normal disc playback Press once; tracking servo OFF Press twice; tracking servo ON * NOTE 2 	TRACKING SERVO ON / OFF Tracking balance (traverse) adjustment TP6(SFR602)
Sled mode	◀◀ key ▶▶ key	All FL light up	<ul style="list-style-type: none"> • Pickup moves to the outermost track • Pickup moves to the innermost track * NOTE 3 (During playback, machine operates normally.) 	SLED SERVO Check SLED mechanism operation

* NOTE 1: There are cases when the tracking servo cannot be locked owing to the protection circuit being operated when heat builds up in the driver IC if the focus search is operated continually for more than 10 minutes. In these cases, the power supply should be switched off for 10 minutes until heat has been reduced and then re-started.

* NOTE 2: Do not press the ◀◀ or ▶▶ keys when the machine is in the || status is active. If they are pressed, playback will not be possible after the || status has been canceled. If the ◀◀ or ▶▶ keys are pressed in the || status, press the ■ key and return to start mode (No. 1).

* NOTE 3: When pressing the ◀◀ or ▶▶ keys, take care to avoid damage to the gears. Because the sled motor is activated when the ◀◀ or ▶▶ keys are pressed, even when the pick-up is at the outermost or innermost track.

4. Operation Outline

The operation of each mode is carried out in the direction of the arrows from the start mode as indicated in the following illustration.

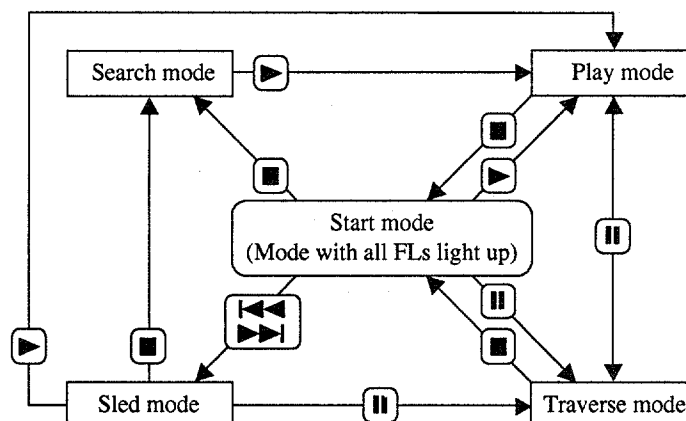

ADJUSTMENT <DECK / CD>

A MAIN C.B

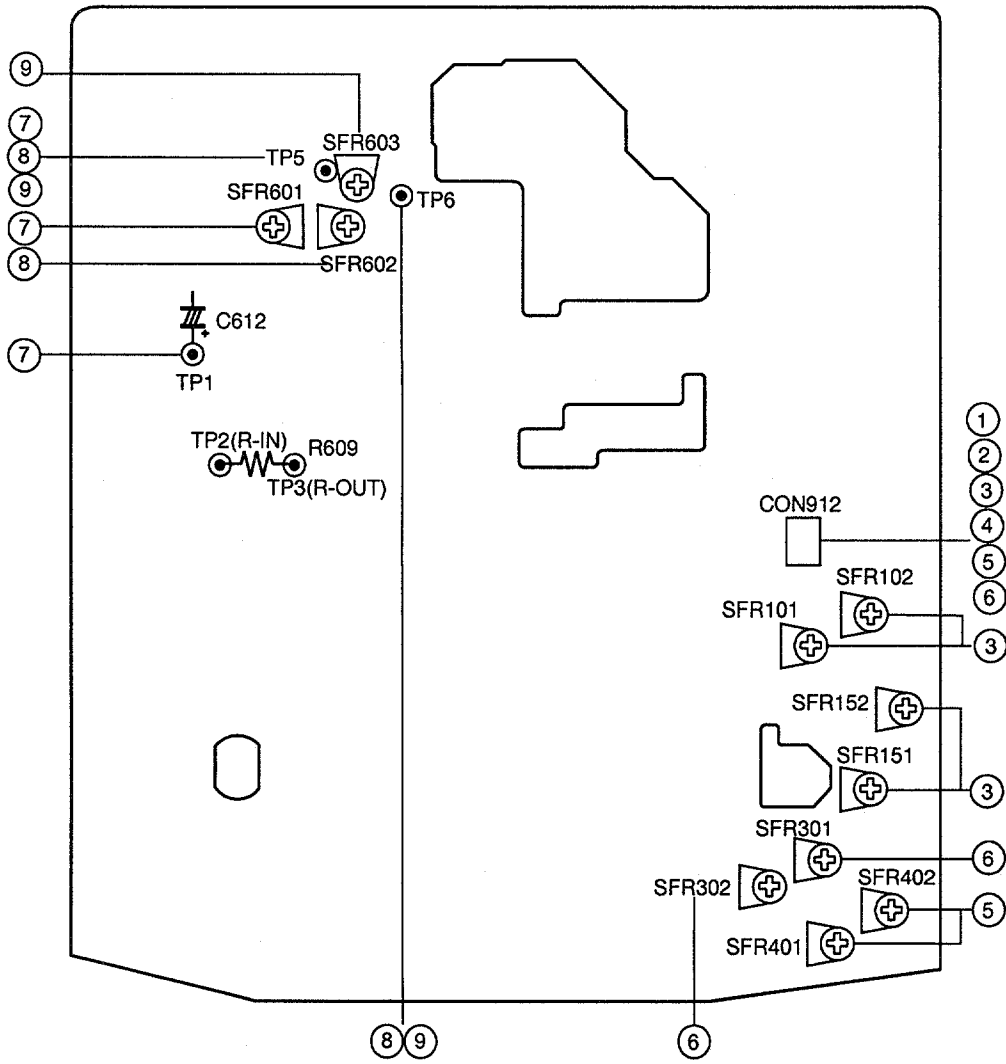

E DECK C.B

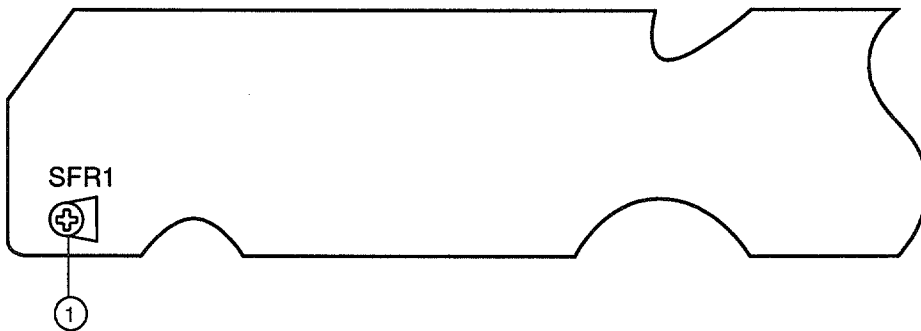

DECK R / P E HEAD

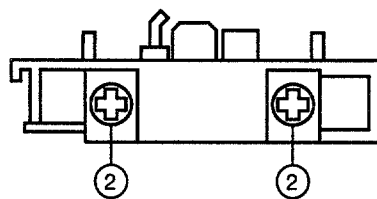

<CD SECTION>

Note : Connect a probe (10:1) of the osilloscope or the frequency counter to a test point.

7. Focus Bias Adjustment

Make the focus bias adjustment when replacing and repairing the optical block.

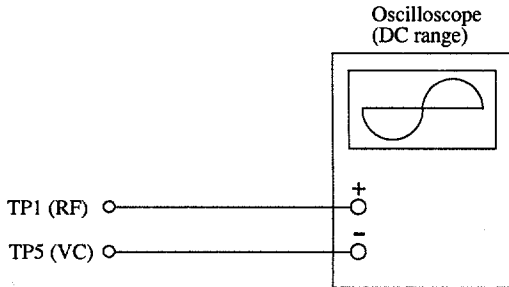

- 1) Connect an oscilloscope to the test points TP1 (RF) and TP5 (VC).
- 2) Turn on the power switch.
- 3) Insert test disc TCD-782 (YEDS-18) and play back the second composition.
- 4) Adjust SFR601 so that the RF signal of the test point TP1 (RF) is MAX and CLEARREST.

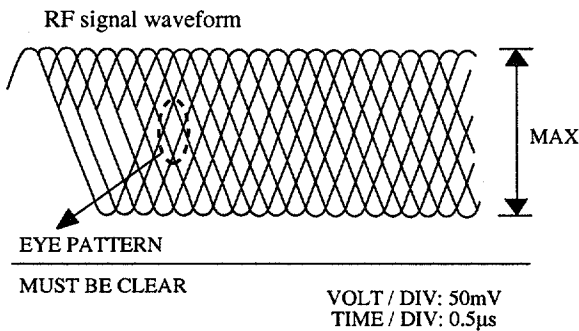

Note : The current of the laser signal can be checked with the voltages on both sides of R628 (10Ω). The difference for the specified value shown on the level must be within ± 6.0mA.

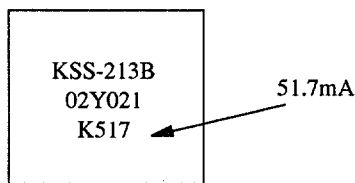

$$\text{Laser current } I_{op} = \frac{\text{Voltage across R628}}{10\Omega}$$

8. Tracking Balance Adjustment

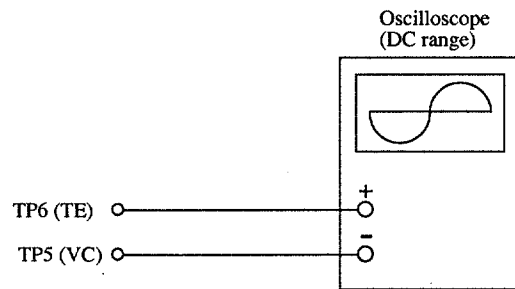

- 1) Connect an oscilloscope to the test points TP6 (TE) and TP5 (VC).
- 2) Start the CD test mode.
- 3) Insert test disc TCD-782 (YEDS-18) and become traverse mode of CD test mode.
- 4) Adjust SFR602 so that the traverse waveform on the oscilloscope is vertically symmetrical as shown in the figure below.
- 5) After the adjustment is completed, remove the connected lead wires from the terminals.
- 6) Cancel the CD test mode.

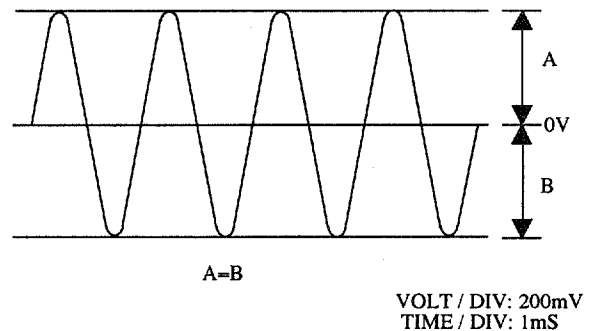

9. Tracking Gain Adjustment

A servo analyzer is necessary in order to perform this adjustment exactly. However, this gain has a margin, so even if it is slightly off, there is no problem. Therefore, do not perform this adjustment.

Focus/tracking gain determines the pick-up follow-up (vertical and horizontal) relative to mechanical noise and mechanical shock when 2-axis device operates. However, as these gains are reciprocate, the adjustment is performed at the point where both gains are satisfied.

- When gain is raised, the noise increases when the 2-axis device operates increases.
- When gain is lowered, it is more susceptible to mechanical shock and skipping occurs more easily.

When gain adjustment is not satisfied, the symptoms below appear.

Symptoms \ Gain	(Focus)	Tracking
<ul style="list-style-type: none"> The time until music starts becomes longer for STOP → ►PLAY or automatic selection (◀▶ buttons pressed.) (Normally takes about 2 seconds.) 	low	low or high
<ul style="list-style-type: none"> Music does not start and disc continues to rotate for STOP → ►PLAY or automatic selection (◀▶ buttons pressed.) 	–	low
<ul style="list-style-type: none"> Disc stops to rotate shortly after STOP → ►PLAY. 	low or high	–
<ul style="list-style-type: none"> Sound is interrupted during PLAY, or time counter display stops. 	–	low
<ul style="list-style-type: none"> More noises during the 2-axis device operation. 	high	high

The following is simple adjustment method.

– Simple adjustment –

Note : Since exact adjustment cannot be performed, remember the positions of the controls before performing the adjustment. If the positions after the simple adjustment are only a little different, return the controls to the original position.

Procedure :

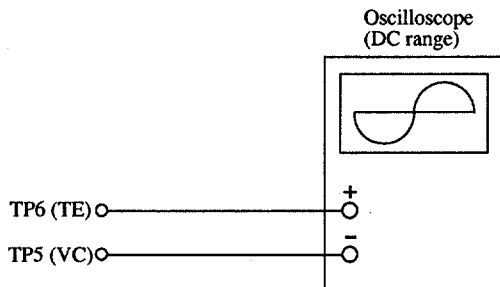

- 1) Keep the set horizontal. (If the set is not kept horizontally, this adjustment cannot be performed due to the gravity against the 2-axis device.)
- 2) Insert test disc TCD-782 (YEDS-18) and play back the second composition.
- 3) Connect an oscilloscope to TP6 (TE) of the 3CD MAIN C.B.
- 4) Adjust SFR603 so that the waveform appears as shown in the figure below. (tracking gain adjustment)

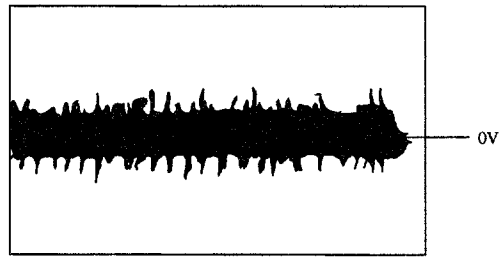

VOLT / DIV: 50mV
TIME / DIV: 1mS

- Incorrect example

Low tracking gain
(The fundamental wave appears as compared with the waveform adjusted)

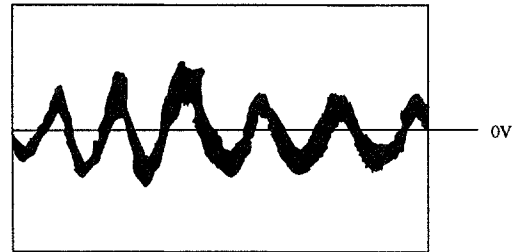

VOLT / DIV: 50mV
TIME / DIV: 1mS

High tracking gain
(The frequency of the fundamental wave is higher than in low gain)

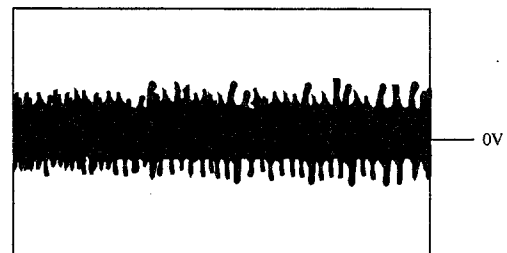

VOLT / DIV: 50mV
TIME / DIV: 1mS

TAPE MECHANISM EXPLODED VIEW 1 / 1

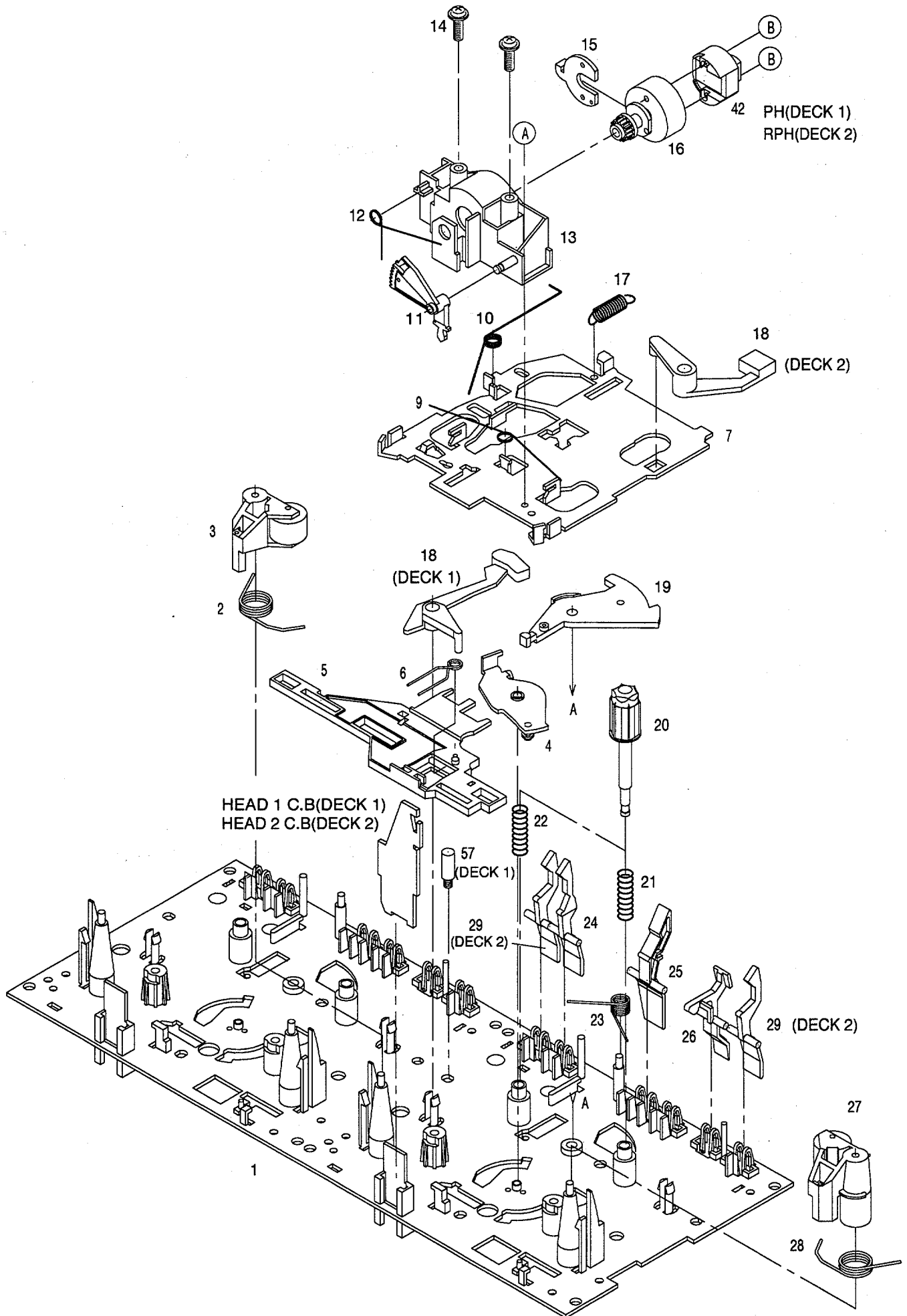

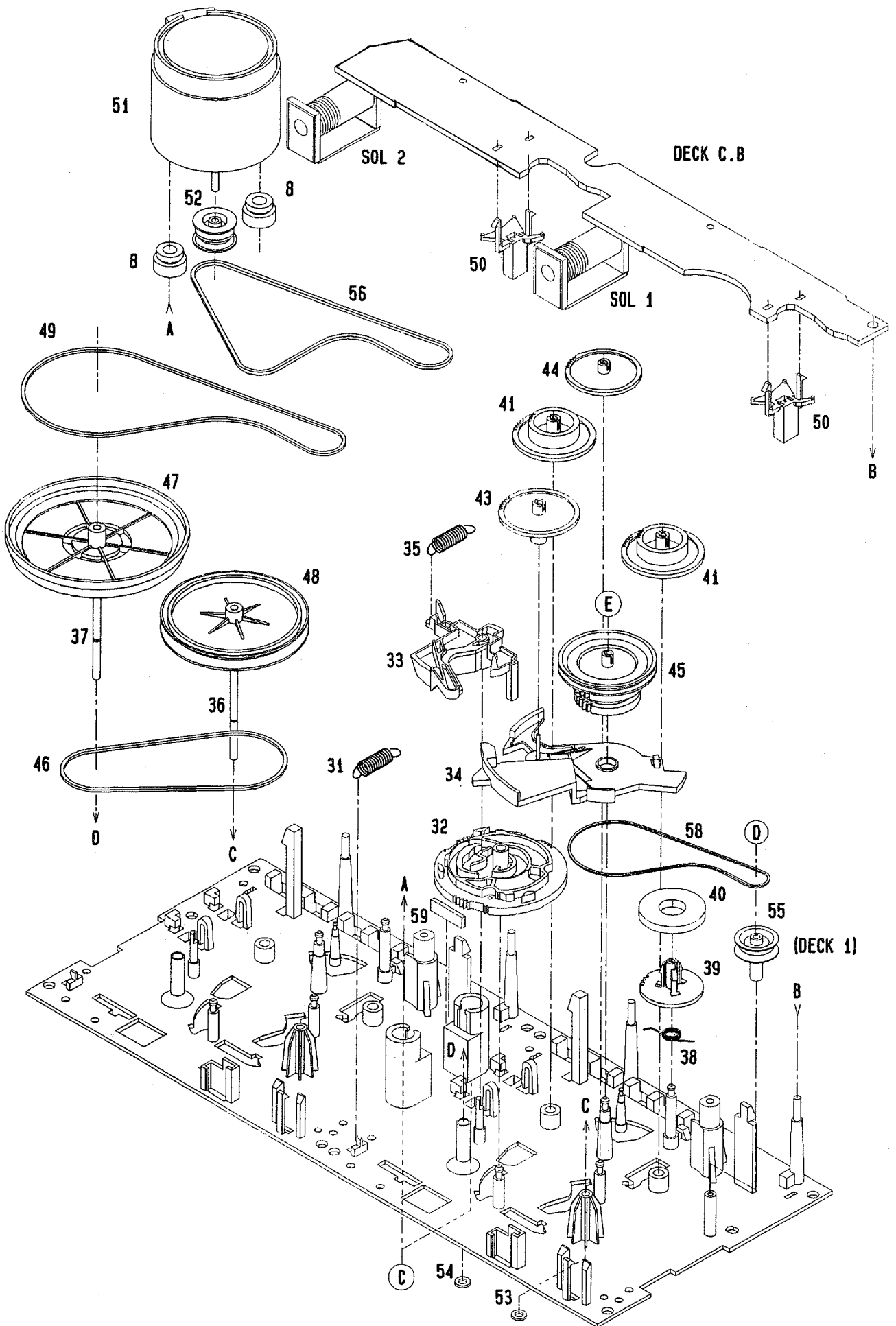

TAPE MECHANISM PARTS LIST 1 / 1

If can't understand for Description please kindly refer to "REFERENCE NAME LIST".

REF. NO.	PART NO.	KANRI NO.	DESCRIPTION	REF. NO.	PART NO.	KANRI NO.	DESCRIPTION
1	82-ZM3-301-519		CHAS ASSY,M2	36	82-ZM1-236-019		CAPSTAN N 2-41.5
2	82-ZM1-258-110		SPR-T,PINCH L	37	82-ZM1-239-019		CAPSTAN N 2.2-41.7
3	82-ZM1-341-110		LVR ASSY,PINCH L2	38	82-ZM1-322-019		SPR-T,FR60
4	82-ZM1-333-010		PLATE,LINK 2	39	82-ZM1-220-219		GEAR,IDLER
5	82-ZM1-266-11K		LVR,DIR	40	82-ZM3-616-019		RING MAGNET 4
6	82-ZM1-214-010		SPR-T,DIR	41	82-ZM1-216-31K		GEAR,REEL
7	82-ZM1-206-81K		CHAS,HEAD	42	87-A90-319-010		HEAD,PH HADKH2 FPC
8	82-ZM3-307-019		CUSH-G,DIA3.7-8-3.2	42	87-A90-320-010		HEAD,RPH HADKH5 FPC
9	82-ZM1-269-219		SPR-T,BRG	43	82-ZM1-225-21K		GEAR,FR
10	82-ZM1-219-119		SPR-T,LINK	44	82-ZM1-226-019		GEAR,REW
11	82-ZM1-210-119		GEAR,H T	45	82-ZM3-333-310		SLIP DISK ASSY 2
12	82-ZM1-213-019		SPR-T,HEAD	46	82-ZM1-338-010		BELT FR4
13	82-ZM1-207-619		GUIDE,TAPE	47	82-ZM1-349-110		FLY-WHL,R W(DECK 2)
14	86-ZM4-206-010		S-SCREW,AZIMUTH	47	82-ZM3-338-110		FLY-WHL,R3 W(DECK 1)
15	82-ZM1-314-119		PLATE,HEAD	48	82-ZM1-348-010		FLY-WHL,L W(DECK 2)
16	82-ZM1-208-119		HLDR,HEAD	48	82-ZM1-348-010		FLY-WHL,L W(DECK 1)
17	82-ZM1-218-019		SPR-E,HB	49	82-ZM3-329-210		BELT,SBU R2
18	82-ZM1-263-110		LVR,EJECT L (DECK 1)	50	82-ZM1-245-210		HLDR,IC
18	82-ZM1-264-010		LVR,EJECT R (DECK 2)	51	87-045-347-019		MOT,SHU2L 70(M1)
19	82-ZM1-222-21K		LVR,PLAY	52	82-ZM3-221-010		PULLEY,MOT 2M
20	82-ZM1-217-319		REEL TABLE	53	82-ZM1-288-019		SH,1.63-3.2-0.5 SLT
21	82-ZM1-244-510		SPR-C,BT	54	80-ZM6-243-019		SH,1.75-3.6-0.5 SLT
22	82-ZM1-285-310		SPR-C,BT L	55	82-ZM3-335-210		PULLEY,COUPLER M3(DECK 1)
23	82-ZM1-257-019		SPR-T,CAS	56	82-ZM3-337-010		BELT,SBU MOT 2
24	82-ZM1-241-319		LVR,MC	57	82-ZM3-339-010		SHAFT,COUPLER N3(DECK 1)
25	82-ZM1-242-019		LVR,CAS	58	86-ZM1-206-010		BELT,MAIN L
26	82-ZM1-243-019		LVR,STOP	59	82-ZM3-340-010		SH,BELT D2
27	82-ZM1-344-110		LVR ASSY,PINCH R2	A	85-ZM3-202-010		S-SCREW,TG
28	82-ZM1-259-110		SPR-T,PINCH R	B	80-ZM6-207-019		V+1.6-7
29	82-ZM1-240-11K		LVR,REC (DECK 2)	C	82-ZM3-318-019		S-SCRW MOTOR M2
31	82-ZM1-255-319		SPR-E,LVR DIR	D	87-B10-043-010		W-P,0.99-4-0.25 SLT
32	82-ZM3-305-01K		GEAR,CAM M2	E	82-ZM3-334-010		PW,2.16-6-0.4
33	82-ZM1-227-21K		LVR,TRIG				
34	82-ZM3-306-11K		LVR,FR M2				
35	82-ZM1-265-119		SPR-E,TRIG				

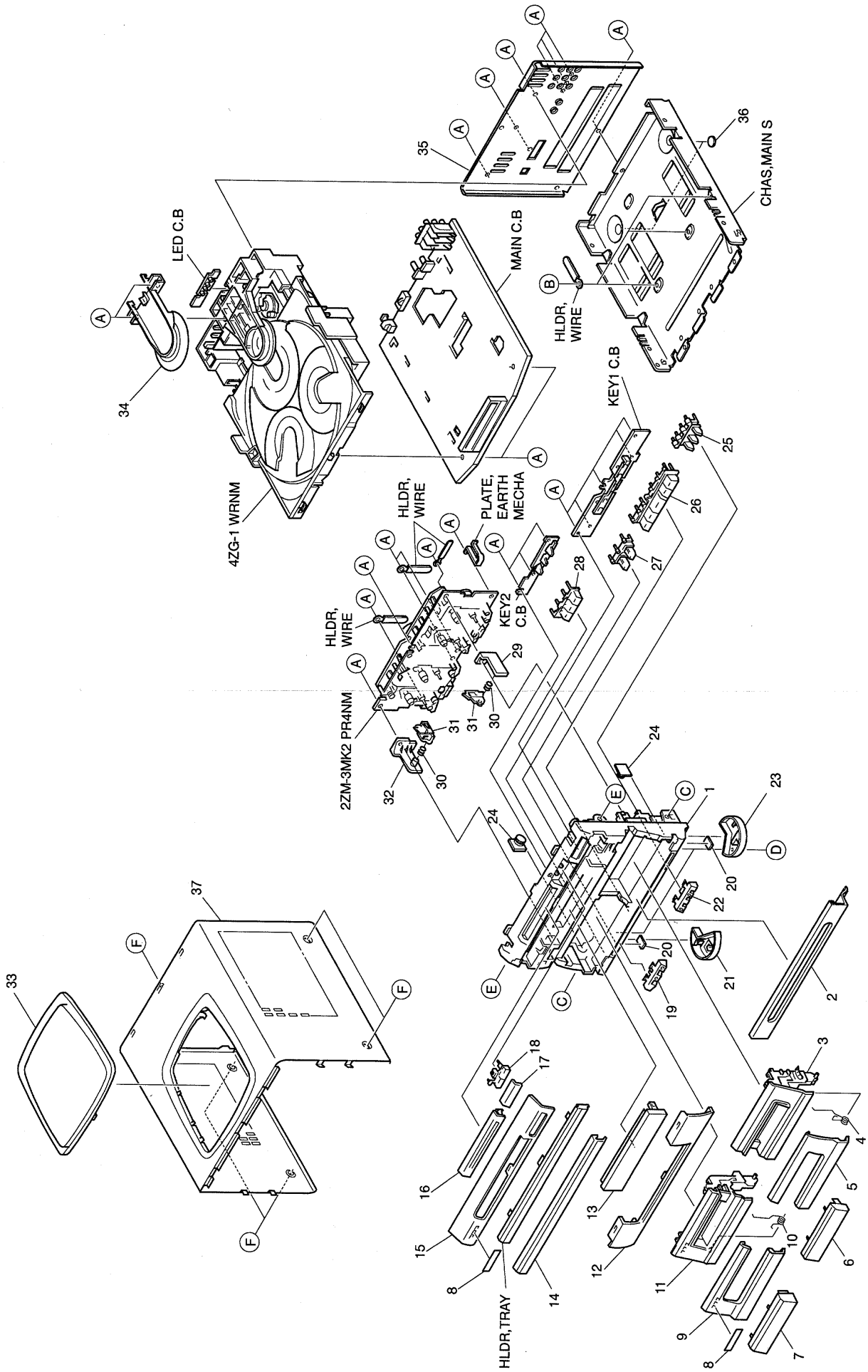

MECHANICAL PARTS LIST 1 / 1

If can't understand for Description please kindly refer to "REFERENCE NAME LIST".

REF.NO.	PART NO.	KANRI NO.	DESCRIPTION	REF.NO.	PART NO.	KANRI NO.	DESCRIPTION
1	87-NV1-001-010		CABI,FR	26	87-NV1-023-010		KEY,ASSY OPE
2	87-NV2-001-010		PANEL,CONTROL	27	87-NV1-013-010		KEY,REC
3	87-NV1-004-010		BOX,CASS 2	28	87-NV1-012-010		KEY,DISC
4	83-NV4-202-110		SPR-T,EJECT 2	29	87-NF4-217-010		HLDR,LOCK 2
5	87-NV1-044-010		PANEL,CASS 2	30	82-NF5-228-010		SPR-C,LOCK
6	87-NV1-009-010		WINDOW,CASS 2	31	82-NF5-229-010		PLATE,LOCK
7	87-NV1-008-010		WINDOW,CASS 1	32	87-NF4-216-010		HLDR,LOCK 1
8	87-B00-002-010		BADGE,AIWA 30 ABS SIL	33	86-NF6-007-010		WINDOW,TOP
9	87-NV1-043-010		PANEL,CASS 1	34	84-2G1-011-010		REFLECTOR,CD
10	83-NV4-201-110		SPR-T,EJECT 1	35	87-NV2-003-010		PANEL,REAR YSNM
11	87-NV1-003-010		BOX,CASS 1	36	82-NV1-213-010		FELT,DIAL2-2
12	87-NV1-042-010		PANEL,DISPLAY	37	87-NV1-010-010		CABI,STEEL
13	87-NV1-006-010		WINDOW,DISPLAY	A	87-067-703-010		TAPPING SCREW, BVT2+3-10
14	87-NV1-041-010		PANEL,TRAY	B	87-571-092-410		TAPPING SCREW, VIT+3-4
15	87-NV1-040-010		PANEL,CD	C	87-591-094-410		TAPPING SCREW, QIT+3-6
16	87-NV1-007-010		WINDOW,CD	D	87-067-777-010		BVTT+3-6 BLK W/CONVEX
17	87-NV1-046-010		PANEL,OPEN	E	87-721-097-410		QT2+3-12 GLD
18	87-NV1-011-010		KEY,OPEN	F	87-067-641-010		UTT2+3-8(W/O SLOT)BL
19	87-NV1-047-010		PANEL,KEY REC				
20	80-VT1-202-010		FELT,12.5-15.5-2				
21	87-NT1-015-010		RING,FOOT L				
22	87-NV1-048-010		PANEL,KEY DOLBY				
23	87-NT1-035-010		RING,FOOT R				
24	87-063-165-010		OIL-DMPR 150				
25	87-NV1-014-010		KEY,DOLBY				

SPRING APPLICATION POSITION

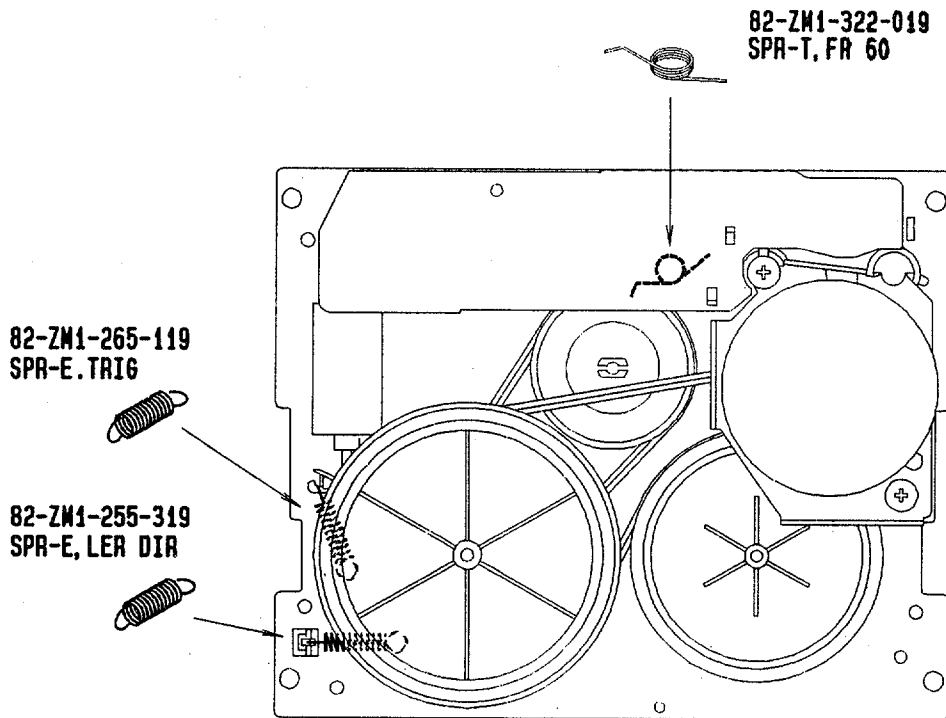

SPEAKER DISASSEMBLY INSTRUCTIONS

Type.1

矢印の位置にマイナスドライバーを差し込んで、パネルを外します。各々のスピーカーユニットのビスを取り、スピーカーユニットを外してください。

Insert a flat-bladed screwdriver into the position indicated by the arrows and remove the panel. Remove the screws of each speaker unit and then remove the speaker units.

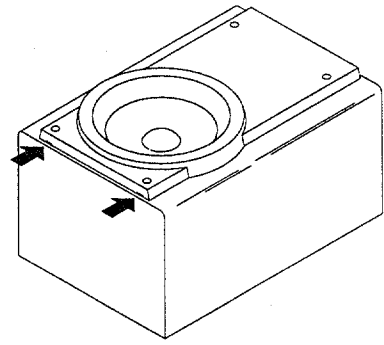

Type.2

グリルフレームを外し、4個のゴムキャップをマイナスドライバーで端の方から持ち上げて外すと中にビスが有りますので、ビスを取り外します。矢印の位置にマイナスドライバーを差し込んで、パネルを外します。各々のスピーカーユニットのビスを取り、スピーカーユニットを外してください。

Remove the grill frame and four pieces of rubber caps by pulling out with a flat-bladed screwdriver. Remove the screws from hole where installed rubber caps. Insert a flat-bladed screwdriver into the position indicated by the arrows and remove the panel. Remove the screws of each speaker unit and then remove the speaker units.

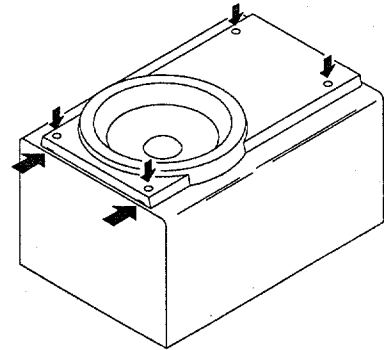

Type.3

矢印の位置にマイナスドライバーを差し込んで、パネルを外します。各々のスピーカーユニットの凹にマイナスドライバーを差し込んで、反時計方向に回転させスピーカーユニットを外してください。スピーカーユニット交換後は時計方向にクリック音がするまで、回転させて取り付けます。

Insert a flat-bladed screwdriver into the position indicated by the arrows and remove the panel. Turn the speaker unit to counter-clockwise direction while inserting a flat-bladed screwdriver into one of the hollows around speaker unit, and then remove the speaker unit. After replacing the speaker unit, install it turning to clockwise direction until "click" sound comes out.

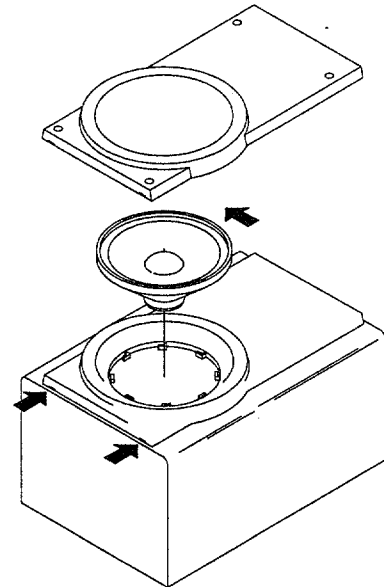

SPEAKER PARTS LIST (SX-NAVH80 <YJ,YT,YB>)

If can't understand for Description please kindly refer to "REFERENCE NAME LIST".

REF. NO.	PART NO.	KANRI NO.	DESCRIPTION
1	87-NSM-001-019		PANEL, FR
2	87-NSM-002-019		PANEL, TW
3	87-NSM-008-019		GRILLE, FRAME ASSY
4	87-NSM-010-019		PROTECTOR
5	83-MS2-603-119		SPKR, T 60
6	87-NSN-602-019		SPKR, W 160
7	86-NSN-610-019		TERMINAL, ASSY
8	87-NSY-610-019		SPKR, CODE

SPEAKER PARTS LIST (SX-R270 <YU,YS>)

If can't understand for Description please kindly refer to "REFERENCE NAME LIST".

REF. NO.	PART NO.	KANRI NO.	DESCRIPTION
1	87-YS1-004-019		GRILLE, FRAME ASSY
2	81-VSA-010-019		SPKR, CORD
3	85-NSX-601-019		SPKR, 100

SPEAKER PARTS LIST (SX-C600 <YU>)

If can't understand for Description please kindly refer to "REFERENCE NAME LIST".

REF. NO.	PART NO.	KANRI NO.	DESCRIPTION
1	87-YS3-001-019		PANEL, FR ST
2	87-YS3-002-019		PANEL, REAR ST
3	87-YS3-003-019		GRILLE, FRAME ASSY
4	85-NSY-602-019		SPKR, 10
5	83-NSM-010-019		SPKR, CORD

SPEAKER PARTS LIST (SX-C400 <YJ, Y>)

If can't understand for Description please kindly refer to "REFERENCE NAME LIST".

REF. NO.	PART NO.	KANRI NO.	DESCRIPTION
1	85-NSY-017-010		GRILLE FRAME ASSY B<YJA, YA, YJ7A>
1	85-NSY-010-010		GRILLE FRAME ASSY<EXCEPT YJA, YA, YJ7A>
2	85-NSY-001-010		PANEL, FR<YJB, YB, YJ7B>
2	85-NSY-011-010		PANEL, FR ST<YST, ST, YJST, YJ7ST, YJA, YA, YJ7A>
3	85-NSY-002-010		PANEL, REAR<YJB, YB, YJ7B>
3	85-NSY-012-010		PANEL, REAR ST<YST, ST, YJST, YJ7ST, YJA, YA, YJ7A>
4	85-NSY-602-010		SPEAKER
5	83-NSM-010-010		SPEAKER, CORD

SPEAKER PARTS LIST (SX-R230 <YJ, Y>)

If can't understand for Description please kindly refer to "REFERENCE NAME LIST".

REF. NO.	PART NO.	KANRI NO.	DESCRIPTION
1	85-NSX-015-010		GRILLE FRAME ASSY B<YJA, YA, YJ7A>
1	85-NSX-005-010		GRILLE FRAME ASSY<EXCEPT YJA, YA, YJ7A>
2	85-NSX-001-010		PANEL, FR<YJB, YB, YJ7B>
2	85-NSX-009-010		PANEL, FR<YST, ST, YJST, YJ7ST, YJA, YA, YJ7A>
3	85-NSX-002-010		PANEL, REAR<YJB, YB, YJ7B>
3	85-NSX-010-010		PANEL, REAR<YST, ST, YJST, YJ7ST, YJA, YA, YJ7A>
4	85-NSX-601-010		SPEAKER
5	81-VSA-010-010		SPEAKER, CORD

ACCESSORIES / PACKAGE LIST

If can't understand for Description please kindly refer to "REFERENCE NAME LIST".

REF. NO.	PART NO.	KANRI NO.	DESCRIPTION
1	87-NTN-906-010		IB,E(EGFSI)E<EZ>
1	87-NTN-905-010		IB,K(E)M<K>
2	85-NT3-661-010		RC-T506
3	87-006-225-010		AM LOOP ANT NC2
4	87-043-106-010		WIRE, FM ANT (Z)

REFERENCE NAME LIST

ELECTRICAL SECTION

DESCRIPTION	REFERENCE NAME
ANT	ANTENNAS
C-	CHIP
C-CAP	CAP, CHIP
C-CAP TN	CAP, CHIP TANTALUM
C-COIL	COIL, CHIP
C-DI	DIODE, CHIP
C-DIODE	DIODE, CHIP
C-FET	FET, CHIP
C-FOTR	FILTER, CHIP
C-JACK	JACK, CHIP
C-LED	LED, CHIP
C-RES	RES, CHIP
C-SFR	SFR, CHIP
C-SLIDE SW	SLIDE SWITCH, CHIP
C-SW	SWITCH, CHIP
C-TR	TRANSISTOR, CHIP
C-VR	VOLUME, CHIP
C-ZENER	ZENER, CHIP
CAP, CER	CAP, CERA-SOL
CAP, E	CAP, ELECT
CAP, M/F	CAP, FILM
CAP, TC	CAP, CERA-SOL
CAP, TC-U	CAP, CERA-SOL SS
CAP, TN	CAP, TANTALUM
CERA FIL	FILTER, CERAMIC
CF	FILTER, CERAMIC
DL	DELAY LINE
E/CAP	CAP, ELECT
FILT	FILTER
FLTR	FILTER
FUSE RES	RES, FUSE
MOT	MOTOR
P-DIODE	PHOTO DIODE
P-SNSR	PHOTO SENSER
P-TR	PHOTO TRANSISTOR
POLY VARI	VARIABLE CAPACITOR
PPCAP	CAP, PP
PT	POWER TRANSFORMER
PTR, RES	PTR, MELF
RC	REMOTE CONTROLLER
RES NF	RES, NON-FLAMMABLE
RESO	RESONATOR
SHLD	SHIELD
SOL	SOLENOID
SPKR	SPEAKER
SW, LVR	SWITCH, LEVER
SW, RTRY	SWITCH, ROTARY
SW, SL	SWITCH, SLIDE
TC CAP	CAP, CERA-SOL
THMS	THERMISTOR
TR	TRANSISTOR
TRIMER	CAP, TRIMMER
TUN-CAP	VARIABLE CAPACITOR
VIB, CER	RESONATOR, CERAMIC
VIB, XTAL	RESONATOR, CRYSTAL
VR	VOLUME
ZENER	DIODE, ZENER

MECHANICAL SECTION

DESCRIPTION	REFERENCE NAME
ADHESHIVE	SHEET ADHESHIVE
AZ	AZIMUTH
BAR-ANT	BAR-ANTENNA
BAT	BATTERY
BATT	BATTERY
BRG	BEARING
BTN	BUTTON
CAB	CABINET
CASS	CASSETTE
CHAS	CHASSIS
CLR	COLLAR
CONT	CONTROL
CRSR	CURSOR
CU	CUSHION
CUSH	CUSHION
DIR	DIRECTION
DUBB	DUBBING
FL	FRONT LOADING
FLY-WHL	FLYWHEEL
FR	FRONT
FUN	FUNCTION
G-CU	G-CUSHION
HDL	HANDOL
HIMERON	CLOTH
HINGE, BAT	HINGE, BATTERY
HLDR	HOLDER
HT-SINK	HEAT SINK
IB	INSTRUCTION BOOKLET
IDLE	IDLER
IND, L-R	INDICATOR, L-R
KEY, CONT	KEY, CONTROL
KEY, PRGM	KEY, PROGRAM
KNOB, SL	KNOB, SLIDE
LBL	LABEL
LID, BATT	LID, BATTERY
LID, CASS	LID, CASSETTE
LVR	LEVER
P-SP	P-SPRING
PANEL, CONT	PANEL, CONTROL
PANEL, FR	PANEL, FRONT
PRGM	PROGRAM
PULLY, LOAD MO	PULLY, LOAD MOTOR
RBN	RIBBON
S-	SPECIAL
SEG	SEGMENT
SH	SHEET
SHLD-SH	SHIELD-SHEET
SL	SLIDE
SP	SPRING
SP-SCREW	SPECIAL-SCREW
SPACER, BAT	SPACER, BATTERY
SPR	SPRING
SPR-P	P-SPRING
SPR-PC-PUSH	P-SPRING, C-PUSH
T-SP	T-SPRING
TERM	TERMINAL
TRIG	TRIGGER
TUN	TUNING
VOL	VOLUME
W	WASHER
WHL	WHEEL
WORM-WHL	WORM-WHEEL

サービス技術ニュース	
番号	連絡内容
G-	-
G-	-
G-	-

アイワ株式会社
AIWA CO., LTD.

9301978, 750038

Tokyo Japan