

SERVICE MANUAL

CD STEREO SYSTEM

BASIC TAPE MECHANISM : CMAL1Z223A
 BASIC CD MECHANISM : 3ZG-3 E2NC

SYSTEM	CD CASSEIVER	SPEAKER	REMOTE CONTROLLER
XR-EM52	CX-LEM52	SX-LEM52	RC-CAS06

- This Service Manual is the "Revision Publishing" and replaces "Simple Manual" of XR-EM52 <EZ(S)>, (S/M Code No. 09-022-455-9T1).

TABLE OF CONTENTS

SPECIFICATIONS	3
PROTECTION OF EYES FROM LASER BEAM DURING SERVICING	4
ELECTRICAL PARTS LIST (CX – LEM52)	5 ~ 14
ELECTRICAL PARTS LIST (CZA – 3)	15 ~ 17
ELECTRICAL PARTS LIST (3ZG – 3)	18
ELECTRICAL PARTS LIST (3ZG – 2)	19
CHIP RESISTOR PART CODE	20
TRANSISTOR ILLUSTRATION	20
WIRING – 1 (MAIN) <1 / 2>	21
WIRING – 1 (MAIN) <2 / 2>	22
SCHEMATIC DIAGRAM – 1 (MAIN / KEY (1 / 2))	23
WIRING – 2 (FRONT) <1 / 2>	24
WIRING – 2 (FRONT) <2 / 2>	25
SCHEMATIC DIAGRAM – 2 (FRONT / DECK)	26
WIRING – 3 (CD) <1 / 2>	27
WIRING – 3 (CD) <2 / 2>	28
SCHEMATIC DIAGRAM – 3 (CD / DRIVE / LOAD)	29
WIRING – 4 (TUNER)	30
SCHEMATIC DIAGRAM – 4 (TUNER)	31
WIRING – 5 (PT)	32
SCHEMATIC DIAGRAM – 5 (PT)	33
WIRING – 6 (KEY) <1 / 2>	34
WIRING – 6 (KEY) <2 / 2>	35
SCHEMATIC DIAGRAM – 6 (KEY (2 / 2))	36
WIRING – 7 (DECK / DRIVE / LOAD)	37
IC BLOCK DIAGRAM	38 ~ 39
FL (11 – BT – 193GNK) GRID ASSIGNMENT AND ANODE CONNECTION	40
IC DESCRIPTION	41 ~ 45
VOLTAGE CHART	46 ~ 48
ADJUSTMENT	49 ~ 56
CD TEST MODE	57
MECHANICAL EXPLODED VIEW	58
MECHANICAL PARTS LIST	59
COLOR NAME TABLE	60
TAPE MECHANISM EXPLODED VIEW	61
TAPE MECHANISM PARTS LIST	62
CD MECHANISM EXPLODED VIEW 1 / 2 <3ZG – 3>	63
CD MECHANISM PARTS LIST 1 / 2 (3ZG – 3)	64
CD MECHANISM EXPLODED VIEW 2 / 2 <3ZG – 2>	65
CD MECHANISM PARTS LIST 2 / 2 (3ZG – 2)	66
GENERAL SPEAKER DISASSEMBLY INSTRUCTIONS (FOR REFERENCE)	67
SPEAKER PARTS LIST (SX – LEM52)	68
ACCESSORIES PARTS LIST (CX – LEM52)	69
OTHER PARTS LIST (CX – LEM52)	70
OTHER PARTS LIST (CZA – 3)	71
OTHER PARTS LIST (3ZG – 3)	72

SPECIFICATIONS

TUNER

FM tuning range	87.5 MHz to 108 MHz
FM usable sensitivity (IHF)	16.8 dBf
FM antenna terminal	75 ohms (unbalanced)
MW tuning range	531 kHz to 1602 kHz (9 kHz step) 530 kHz to 1710 kHz (10 kHz step)
MW usable sensitivity	350 μ V/m
LW tuning range	144 kHz to 290 kHz
LW usable sensitivity	1400 μ V/m
MW/LW antenna	Loop antenna

AMPLIFIER

Power output	Rated: 16 W + 16 W (6 ohms, T.H.D. 1 %, 1 kHz/DIN 45500) Reference: 20 W + 20 W (6 ohms, T.H.D. 10 %, 1 kHz/DIN 45324) DIN MUSIC POWER 45 W + 45 W
Input	AUX IN: 500 mV
Outputs	SPEAKERS: 6 ohms or more PHONES: 32 ohms or more

CASSETTE DECK

Track format	4 tracks, 2 channels stereo
Frequency response	50 Hz – 10000 Hz
Recording system	AC bias
Heads	Recording/playback x 1, erase x 1

CD PLAYER

Laser	Semiconductor laser ($\lambda = 780$ nm)
D/A converter	1 bit dual
Signal-to-noise ratio	80 dB (1 kHz, 0 dB)
Wow and flutter	Unmeasurable

GENERAL

Power requirements	230 V AC, 50 Hz
Power consumption	60 W
Power consumption in standby mode	With ECO mode on: 0.7 W With ECO mode off: 10.0 W
Dimensions (W x H x D)	190 x 250 x 271.4 mm
Weight	3.5 kg

SPEAKER SYSTEM SX-LEM52

Speaker system	2 way, bass reflex (magnetic shielded)
Speaker units	Woofers: 120 mm cone Tweeter: 25 mm dome
Impedance	6 ohms
Dimensions (W x H x D)	155 x 250 x 218 mm
Weight	2.4 kg

- Design and specifications are subject to change without notice.

PROTECTION OF EYES FROM LASER BEAM DURING SERVICING

This set employs laser. Therefore, be sure to follow carefully the instructions below when servicing.

WARNING!!

WHEN SERVICING, DO NOT APPROACH THE LASER EXIT WITH THE EYE TOO CLOSELY. IN CASE IT IS NECESSARY TO CONFIRM LASER BEAM EMISSION. BE SURE TO OBSERVE FROM A DISTANCE OF MORE THAN 30cm FROM THE SURFACE OF THE OBJECTIVE LENS ON THE OPTICAL PICK-UP BLOCK.

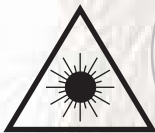

- Caution: Invisible laser radiation when open and interlocks defeated avoid exposure to beam.
- Advarsel: Usynlig laserstråling ved åbning, når sikkerhedsafbrydere er ude af funktion. Undgå udsættelse for stråling.

VAROITUS!

Laiteen Käyttäminen muulla kuin tässä käyttöohjeessa mainitulla tavalla saattaa altistaa käyttäjän turvallisuusluokan 1 ylittävälle näkymättömälle lasersäteilylle.

WARNING!

Om apparaten används på annat sätt än vad som specificeras i denna bruksanvisning, kan användaren utsättas för osynlig laserstrålning, som överskrider gränsen för laserklass 1.

CAUTION

Use of controls or adjustments or performance of procedures other than those specified herein may result in hazardous radiation exposure.

ATTENTION

L'utilisation de commandes, réglages ou procédures autres que ceux spécifiés peut entraîner une dangereuse exposition aux radiations.

ADVARSEL

Usynlig laserstråling ved åbning, når sikkerhedsafbrydere er ude af funktion. Undgå udsættelse for stråling.

This Compact Disc player is classified as a CLASS 1 LASER product.

The CLASS 1 LASER PRODUCT label is located on the rear exterior.

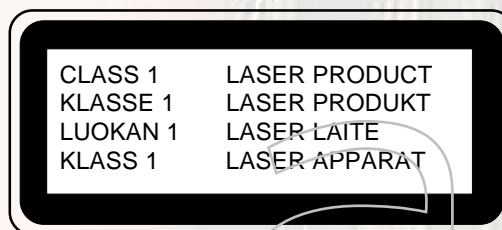

Precaution to replace Optical block

(KSS-213F)

Body or clothes electrostatic potential could ruin laser diode in the optical block. Be sure ground body and workbench, and use care the clothes do not touch the diode.

- 1) After the connection, remove solder shown in right figure.

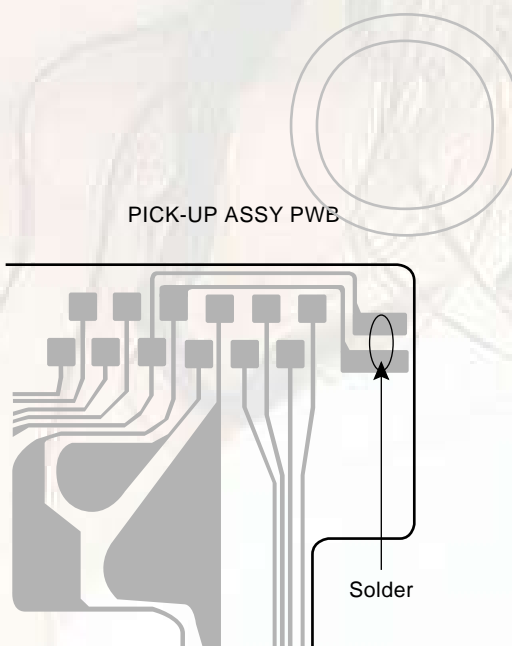

ELECTRICAL PARTS LIST (CX – LEM52)

! = Δ SAFETY PARTS
 C = Components marked

All components used on this model at the production line are shown in this service manual.
 However, please note that not all components will be available as spare parts for after-sales service.
 Components marked S and O are designated as spare parts for service and will be stocked at the spare parts centers.
 Components marked X and R are not designated as spare parts for after sales service, and will not be stocked at the spare parts centers.

UNIT-NAME	! C	REF-NO	PARTS-NO	PARTS-NAME	SUFFIX&MODEL
					CX-LEM52 EZSC
CD	O C	001A	87-010-759-08	C-CAP,U, 0.1-25F	a
CD	O C	002A	87-010-263-08	CAP, ELECT 100-10V	a
CD	O C	003A	87-012-274-08	CHIP CAP,U 1000P-50B	a
CD	O C	0043	87-012-274-08	C-CAP, U 1000P-50B	a
CD	O C	0044	87-012-274-08	C-CAP, U 1000P-50B	a
CD	O C	004A	87-010-759-08	C-CAP,U, 0.1-25F	a
CD	O C	005A	87-010-263-08	CAP, ELECT 100-10V	a
CD	O C	0101	87-010-194-08	C-CAP,U0.047UF 25V K X7R CER	a
CD	O C	0104	87-012-282-08	C-CAP, U 4700P-50	a
CD	O C	0105	87-010-759-08	C-CAP,U, 0.1-25F	a
CD	O C	0107	87-010-263-08	CAP, ELECT 100-10V	a
CD	O C	0108	87-010-759-08	C-CAP,U, 0.1-25F	a
CD	O C	0109	87-010-263-08	CAP, ELECT 100-10V	a
CD	O C	0110	87-010-405-08	CAP, ELECT 10-50V	a
CD	O C	0111	87-010-401-08	CAP, ELECT 1-50V	a
CD	O C	0113	87-012-284-08	C-CAP,U 6800P-50V	a
CD	O C	0114	87-012-188-08	C-CAP,U 47P-50 CH	a
CD	O C	0115	87-010-759-08	C-CAP,U, 0.1-25F	a
CD	O C	0116	87-010-263-08	CAP, ELECT 100-10V	a
CD	O C	0117	87-010-263-08	CAP, ELECT 100-10V	a
					CX-LEM52 EZSC
CD	O C	0118	87-010-759-08	C-CAP,U, 0.1-25F	a
CD	O C	0119	87-010-759-08	C-CAP,U, 0.1-25F	a
CD	O C	0120	87-012-156-08	C-CAP,U 220P-50V K X7R	a
CD	O C	0121	87-010-263-08	CAP, ELECT 100-10V	a
CD	O C	0122	87-010-759-08	C-CAP,U, 0.1-25F	a
CD	O C	0123	87-012-169-08	C-CAP,U 7P-50 CH	a
CD	O C	0124	87-012-172-08	CAPACITOR CHIP U 10P CH	a
CD	O C	0126	87-010-403-08	CAP, ELECT 3.3-50V	a
CD	O C	0127	87-010-759-08	C-CAP,U, 0.1-25F	a
CD	O C	0128	87-010-194-08	C-CAP,U 0.047UF 25V K X7R CER	a
CD	O C	0129	87-010-403-08	CAP, ELECT 3.3-50V	a
CD	O C	0130	87-010-759-08	C-CAP,U, 0.1-25F	a
CD	O C	0131	87-010-759-08	C-CAP,U, 0.1-25F	a
CD	O C	0132	87-010-263-08	CAP, ELECT 100-10V	a
CD	O C	0133	87-010-405-08	CAP, ELECT 10-50V	a
CD	O C	0134	87-010-759-08	C-CAP,U, 0.1-25F	a
CD	O C	0135	87-010-248-08	CAP, E 220-10M 11L SME	a
CD	O C	0136	87-010-759-08	C-CAP,U, 0.1-25F	a
CD	O C	0138	87-010-759-08	C-CAP,U, 0.1-25F	a
CD	O C	0139	87-010-401-08	CAP, ELECT 1-50V	a
					CX-LEM52 EZSC
CD	O C	0203	87-010-236-08	CAP, ELECT 1000-10M SME	a
CD	O C	0204	87-010-759-08	C-CAP,U, 0.1-25F	a
CD	O C	0205	87-010-402-08	CAP, ELECT 2.2-50V	a
CD	O C	0206	87-010-112-08	CAP, ELECT 100-16V	a
CD	O C	0207	87-012-286-08	C-CAP, U 0.01-25	a
CD	O C	0212	87-010-759-08	C-CAP,U, 0.1-25F	a
CD	O C	0213	87-010-112-08	CAP, ELECT 100-16V	a
CD	O C	0306	87-010-759-08	C-CAP,U, 0.1-25F	a
CD	O C	0310	87-012-279-08	CHIP CAP,U 2700P-50B	a
CD	O C	0401	87-012-195-08	C-CAP,U 100P-50CH	a
CD	O C	0402	87-012-195-08	C-CAP,U 100P-50CH	a
CD	O C	0403	87-012-195-08	C-CAP,U 100P-50CH	a
CD	O C	0404	87-012-195-08	C-CAP,U 100P-50CH	a
CD	O C	0405	87-012-195-08	C-CAP,U 100P-50CH	a
CD	O C	0411	87-010-112-08	CAP, ELECT 100-16V	a
CD	O C	0412	87-012-286-08	C-CAP, U 0.01-25	a
CD	O C	0603	87-012-180-08	C-CAP,U 22P-50 CH	a
CD	O C	102A	87-010-759-08	C-CAP,U, 0.1-25F	a
CD	O C	103A	87-012-188-08	C-CAP,U 47P-50CH	a
CD	O C	106A	87-010-263-08	CAP, ELECT 100-10V	a
					CX-LEM52 EZSC
CD	O C	304A	87-012-274-08	CHIP CAP,U 1000P-50B	a
CD	O C	307A	87-010-391-08	CAP,E 10-35 SME	a
CD	O C	308A	87-010-391-08	CAP,E 10-35 SME	a
CD	O C	309A	87-012-279-08	CHIP CAP,U 2700P-50B	a
CD	O CN	0001	87-A60-424-01	CONN,16P V TOC-B	a
CD	O CN	0201	87-099-199-01	CONN,6P H BLK 6216	a
CD	O CN	0402	86-NFZ-675-01	CONN,05P H 6215	a
CD	O CN	301A	87-A60-081-01	CONN, 06P H 9604	a
CD	O CN	401A	87-A60-080-01	CONN,07P H 9604S-07F	a
CD	S D	0102	87-A40-747-08	ZENER,UZ5.1BSB	a
CD	S D	101A	87-A40-742-08	ZENER,UZ4.3BSA	a
CD	O	FFC0001	88-CL4-704-01	FF-CABLE,16P 1.0 150MM CD-PIC	a
CD	O	FFC0201	88-906-131-11	FF-CABLE,6P 1.25	a
CD	O	FFC0402	88-905-231-11	FF-CABLE 5P 1.25	a
CD	S IC	0010	87-001-982-01	IC,TA7291S	a
CD	S IC	0101	87-A22-242-03	C-IC,LC78646E	a
CD	S IC	0202	87-A22-251-04	C-IC,BA5826FF	a
CD	X JW	0126	88-121-101-08	RES,100-1/8W J	a
CD	O JW	0127	S1-8A8-435-56	F-BEAD 843556 TB36	a
CD	X JW	0128	88-121-101-08	RES,100-1/8W J	a

! = Δ SAFETY PARTS
 C = Components marked

All components used on this model at the production line are shown in this service manual.
 However, please note that not all components will be available as spare parts for after-sales service.
 Components marked S and O are designated as spare parts for service and will be stocked at the spare parts centers.
 Components marked X and R are not designated as spare parts for after sales service, and will not be stocked at the spare parts centers.

UNIT-NAME	! C	REF-NO	PARTS-NO	PARTS-NAME	SUFFIX&MODEL
					CX-LEM52 EZSC
CD	O	JW	0136 S1-8A8-435-56	F-BEAD 843556 TB36	a
CD	O	JW	0140 S1-8A8-435-56	F-BEAD 843556 TB36	a
CD	O	JW	0143 87-005-849-08	COIL,10UH(CECS)	a
CD	O	JW	0205 S1-8A8-435-56	F-BEAD 843556 TB36	a
CD	O	JW	0401 S1-8A8-435-56	F-BEAD 843556 TB36	a
CD	O	L	0101 87-005-849-08	COIL,10UH(CECS)	a
CD	O	L	0102 S2-604-700-0K	FIXED INDUCTOR 4.4UH	a
CD	S	Q	0001 87-A30-494-08	TR,2SA1980G	a
CD	S	Q	0101 87-A30-630-08	TR,2SC5343GL	a
CD	S	Q	0201 87-A30-494-08	TR,2SA1980G	a
CD	X	R	001A 88-108-333-08	C-RESISTOR, 1/16W 33K	a
CD	X	R	002A 88-108-153-08	C-RESISTOR, 1/16W 15K	a
CD	X	R	003A 88-108-153-08	C-RESISTOR, 1/16W 15K	a
CD	X	R	004A 88-108-153-08	C-RESISTOR, 1/16W 15K	a
CD	X	R	005A 88-108-153-08	C-RESISTOR, 1/16W 15K	a
CD	X	R	006A 88-108-333-08	C-RESISTOR, 1/16W 33K	a
CD	X	R	007A 88-108-181-08	C-RES,U 180-1/16W J	a
CD	X	R	008A 88-108-339-08	C-RESISTOR, 1/16W 3.3	a
CD	X	R	0101 88-108-103-08	C-RESISTOR, 1/16W 10K	a
CD	X	R	0102 88-108-273-08	C-RESISTOR, 1/16W 27K	a
					CX-LEM52 EZSC
CD	X	R	0103 88-108-331-08	CHIP RESISTOR SS,330	a
CD	X	R	0110 88-108-221-08	C-RESISTOR, 1/16W 220	a
CD	X	R	0111 88-108-470-08	C-RES,47 SS	a
CD	X	R	0112 88-108-102-08	C-RESISTOR, 1/16W 1K	a
CD	X	R	0113 88-108-102-08	C-RESISTOR, 1/16W 1K	a
CD	X	R	0114 88-108-102-08	C-RESISTOR, 1/16W 1K	a
CD	X	R	0115 88-108-102-08	C-RESISTOR, 1/16W 1K	a
CD	X	R	0116 88-108-102-08	C-RESISTOR, 1/16W 1K	a
CD	X	R	0117 88-108-102-08	C-RESISTOR, 1/16W 1K	a
CD	X	R	0118 88-108-473-08	C-RESISTOR, 1/16W 47K	a
CD	X	R	0119 88-108-681-08	C-RESISTOR, 1/16W 680	a
CD	X	R	0120 88-108-681-08	C-RESISTOR, 1/16W 680	a
CD	X	R	0121 88-108-123-08	C-RESISTOR, 1/16W 12K	a
CD	X	R	0122 88-108-122-08	C-RES,U 1/2K-1/16W J	a
CD	X	R	0123 88-108-331-08	C-RESISTOR, SS 330	a
CD	X	R	0124 88-108-331-08	C-RESISTOR, SS 330	a
CD	X	R	0125 88-108-471-08	C-RESISTOR, 1/16W 470	a
CD	X	R	0126 88-108-101-08	C-RESISTOR,1/16W 100	a
CD	X	R	0127 88-118-100-08	C-RES,U 10-1/10W J	a
CD	X	R	0130 88-128-103-08	C-RESISTOR, 1/8W 10K	a
					CX-LEM52 EZSC
CD	X	R	0131 88-108-473-08	C-RESISTOR, 1/16W 47K	a
CD	X	R	0132 88-108-102-08	C-RESISTOR, 1/16W 100	a
CD	X	R	0152 88-108-102-08	C-RESISTOR,1/16W 1K	a
CD	X	R	0206 88-108-101-08	C-RESISTOR,1/16W 100	a
CD	X	R	0225 88-108-822-08	C-RESISTOR, 1/16W 8.2K	a
CD	X	R	0226 88-108-153-08	C-RESISTOR, 1/16W 15K	a
CD	X	R	0227 88-128-103-08	C-RESISTOR, 1/8W 10K	a
CD	X	R	0228 88-108-822-08	C-RESISTOR, 1/16W 8.2K	a
CD	X	R	0229 88-140-229-08	RES,2.2-1/2W J	a
CD	X	R	0401 88-108-101-08	C-RESISTOR,1/16W 100	a
CD	X	R	0402 88-108-101-08	C-RESISTOR,1/16W 100	a
CD	X	R	0403 88-108-101-08	C-RESISTOR,1/16W 100	a
CD	X	R	0404 88-108-101-08	C-RESISTOR,1/16W 100	a
CD	X	R	0405 88-108-101-08	C-RESISTOR,1/16W 100	a
CD	X	R	0406 88-108-101-08	C-RESISTOR,1/16W 100	a
CD	X	R	0411 88-108-104-08	C-RESISTOR, 1/16W 100K	a
CD	X	R	0412 88-108-562-08	C-RESISTOR, 1/16W 5.6K	a
CD	X	R	0413 88-148-339-08	C-RES,3.3-1/2W J	a
CD	X	R	0414 88-108-472-08	C-RESISTOR, 1/16W 4.7K	a
CD	X	R	0415 88-108-472-08	C-RES,U 4.7K-1/16W J	a
					CX-LEM52 EZSC
CD	X	R	0416 88-108-562-08	C-RESISTOR, 1/16W 5.6K	a
CD	X	R	0417 88-108-104-08	C-RESISTOR, 1/16W 100K	a
CD	X	R	0418 88-108-103-08	C-RESISTOR, 1/16W 10K	a
CD	X	R	0603 88-108-101-08	C-RESISTOR,1/16W 100	a
CD	X	R	151A 88-108-102-08	C-RESISTOR,1/16W 1K	a
CD	X	R	303A 88-108-104-08	C-RESISTOR, 1/16W 100K	a
CD	X	R	304A 88-108-104-08	C-RESISTOR, 1/16W 100K	a
CD	O	X	0101 87-A70-046-01	VIB,XTAL 16.934MHZ	a
FRONT	O	C	0102 87-012-270-08	C-CAP,U 470P-50 B	a
FRONT	O	C	0103 87-010-263-08	CAP, ELECT 100-10V	a
FRONT	O	C	0106 87-010-263-08	CAP, ELECT 100-10V	a
FRONT	O	C	0301 87-012-348-01	C-CAP, 0.1UF-50V	a
FRONT	O	C	0302 87-012-286-08	C-CAP, U 0.01-25	a
FRONT	O	C	0305 87-012-286-08	C-CAP, U 0.01-25	a
FRONT	O	C	0307 87-010-404-08	CAP, ELECT 4.7-50V	a
FRONT	O	C	0309 87-010-787-08	C-CAP, U 0.022-25	a
FRONT	O	C	0314 87-010-370-08	CAP,E 330-6.3 SME	a
FRONT	O	C	0315 87-010-785-08	C-CAP,U 0.015-25 F	a
FRONT	O	C	0317 87-010-787-08	C-CAP, U 0.022-25	a
FRONT	O	C	0329 87-012-274-08	C-CAP, U 1000P-50	a

! = Δ SAFETY PARTS
 C = Components marked

All components used on this model at the production line are shown in this service manual.
 However, please note that not all components will be available as spare parts for after-sales service.
 Components marked S and O are designated as spare parts for service and will be stocked at the spare parts centers.
 Components marked X and R are not designated as spare parts for after sales service, and will not be stocked at the spare parts centers.

UNIT-NAME	! C	REF-NO	PARTS-NO	PARTS-NAME	SUFFIX&MODEL
					CX-LEM52 EZSC
FRONT	O C	0330	87-A10-137-01	CAP 12PF CER 50V CH	a
FRONT	O C	0331	87-012-184-08	C-CAP,U 33P-50 CH	a
FRONT	O C	0333	87-A11-784-01	CAP MYLAR 0.15UF K 100V	a
FRONT	O C	0340	87-012-286-08	C-CAP, U 0.01-25	a
FRONT	O C	0391	87-A11-155-08	CAP, TC U 0.01-16 Z F	a
FRONT	O C	0393	87-018-195-08	CAP 0.0012UF M CER	a
FRONT	O C	0394	87-A11-859-01	AXIAL CERAMIC CAP 180PF 50V	a
FRONT	O C	0395	87-012-274-08	C-CAP, U 1000P-50	a
FRONT	O C	0396	87-010-553-08	CAP 47UF M ELECT 16V	a
FRONT	O C	0397	87-012-275-08	C-CAP, U 1200P-50	a
FRONT	O C	0398	87-012-286-08	C-CAP, U 0.01-25	a
FRONT	O C	304B	87-010-405-08	CAP, ELECT 10-50V	a
FRONT	O C	308B	87-010-404-08	CAP, ELECT 4.7-50V	a
FRONT	O CN	0302	87-A60-059-01	CONN,08P V 9604S-08C	a
FRONT	O CN	0303	87-A60-131-01	CONN,06P V FE JST	a
FRONT	O CN	301B	87-099-852-01	CONN, 21P H FFC / FPC	a
FRONT	O CN	401B	87-099-195-01	CONN,07P V BLK 6216	a
FRONT	S D	0101	87-070-345-08	DIODE,1N4148	a
FRONT	S D	0104	87-A40-748-08	ZENER,UZ5.6BSA	a
FRONT	S D	0105	87-070-345-08	DIODE,1N4148	a
					CX-LEM52 EZSC
FRONT	S D	0301	87-020-465-08	DIODE,1SS133 (110MA)	a
FRONT	S D	0302	87-020-465-08	DIODE,1SS133 (110MA)	a
FRONT	S D	0318	87-020-465-08	DIODE,1SS133 (110MA)	a
FRONT	S D	0322	87-020-027-08	C-DIODE,1SS184	a
FRONT	O FB	0001	83-XM1-617-08	C-COIL BK2125HM601	a
FRONT	O FFC0302	S1-204-021-00		FF-CABLE, 8P	a
FRONT	O FFC0303	88-906-131-11		FF-CABLE, 6P 1.25	a
FRONT	O FFC0401	88-907-251-11		FF-CABLE, 7P 1.25	a
FRONT	O FFC0502	88-921-101-11		FF-CABLE, 21P 1.25	a
FRONT	O FL	0301	8C-CL5-608-01	FL, 11-BT-193GNK	a
FRONT	S IC	0301	8C-CL5-610-01	C-IC,LC876764A-5Z31	a
FRONT	S IC	0303	87-A21-245-01	IC,RPM6938-V4	a
FRONT	X JR	0301	88-108-270-08	C-RES, 1/16W 27	a
FRONT	X JW	0302	88-121-101-08	RES 1/8W 100	a
FRONT	X JW	0306	88-121-101-08	RES 1/8W 100	a
FRONT	O JW	0332	S1-8A8-435-56	F-BEAD 843556 TB36	a
FRONT	O L	0301	87-A50-333-01	COIL,OSC 9 43MHZ	a
FRONT	S Q	0301	89-327-125-08	C-TR,2SC2712GR	a
FRONT	S Q	0302	89-112-965-08	TR,2SA1296GR	a
FRONT	S Q	0303	89-112-965-08	TR,2SA1296GR	a
					CX-LEM52 EZSC
FRONT	S Q	0304	89-327-125-08	C-TR,2SC2712GR	a
FRONT	S Q	0310	89-327-125-08	C-TR,2SC2712GR	a
FRONT	S Q	0314	87-A30-494-08	TR,2SA1980G	a
FRONT	S Q	0316	87-026-227-08	C-TR,DTA114EK	a
FRONT	X R	0001	88-108-473-08	C-RES, 1/16W 47K	a
FRONT	X R	0005	88-121-223-08	RES, 1/8W 22K	a
FRONT	X R	0007	88-121-223-08	RES, 1/8W 22K	a
FRONT	X R	002B	88-108-223-08	C-RES, 1/16W 22K	a
FRONT	X R	004B	88-108-223-08	C-RES, 1/16W 22K	a
FRONT	X R	0129	88-108-471-08	C-RESISTOR, 1/16W 470	a
FRONT	X R	0148	88-108-102-08	C-RESISTOR, 1/16W 1K	a
FRONT	X R	0149	88-108-153-08	C-RES 1/16W 15K	a
FRONT	X R	0150	88-108-472-08	C-RESISTOR, 1/16W 4.7K	a
FRONT	X R	0301	88-128-102-08	C-RES 1K-1/16W	a
FRONT	X R	0302	88-108-102-08	C-RESISTOR, 1/16W 1K	a
FRONT	X R	0306	88-108-102-08	C-RESISTOR, 1/16W 1K	a
FRONT	X R	0307	88-108-101-08	C-RESISTOR,1/16W 100	a
FRONT	X R	0308	88-108-102-08	C-RESISTOR, 1/16W 1K	a
FRONT	X R	0309	88-108-102-08	C-RESISTOR, 1/16W 1K	a
FRONT	X R	0310	88-121-332-08	RESISTOR, 1/8W 3.3K	a
					CX-LEM52 EZSC
FRONT	X R	0311	88-121-222-08	RESISTOR, 1/8W 2.2K	a
FRONT	X R	0312	88-121-332-08	RESISTOR, 1/8W 3.3K	a
FRONT	X R	0313	88-108-103-08	C-RESISTOR, 1/16W 10K	a
FRONT	X R	0314	88-121-129-08	RES,1.2-1/8W J	a
FRONT	X R	0315	88-108-102-08	C-RESISTOR, 1/16W 1K	a
FRONT	X R	0316	88-108-101-08	C-RESISTOR,1/16W 100	a
FRONT	X R	0317	88-108-103-08	C-RESISTOR, 1/16W 10K	a
FRONT	X R	0318	88-121-102-08	RESISTOR, 1/8W 1K	a
FRONT	X R	0319	88-108-101-08	C-RESISTOR,1/16W 100	a
FRONT	X R	0320	88-108-101-08	C-RESISTOR,1/16W 100	a
FRONT	X R	0321	88-108-101-08	C-RESISTOR,1/16W 100	a
FRONT	X R	0322	88-108-102-08	C-RESISTOR, 1/16W 1K	a
FRONT	X R	0323	83-108-102-08	C-RESISTOR, 1/16W 1K	a
FRONT	X R	0324	88-108-103-08	C-RESISTOR, 1/16W 10K	a
FRONT	X R	0337	88-108-103-08	C-RESISTOR, 1/16W 10K	a
FRONT	X R	0338	88-108-103-08	C-RESISTOR, 1/16W 10K	a
FRONT	X R	0339	88-108-103-08	C-RESISTOR, 1/16W 10K	a
FRONT	X R	0340	88-108-103-08	C-RESISTOR, 1/16W 10K	a
FRONT	X R	0341	88-108-222-08	C-RESISTOR, 1/16W 2.2K	a
FRONT	X R	0342	88-108-222-08	C-RESISTOR, 1/16W 2.2K	a

! = Δ SAFETY PARTS
 C = Components marked

All components used on this model at the production line are shown in this service manual.
 However, please note that not all components will be available as spare parts for after-sales service.
 Components marked S and O are designated as spare parts for service and will be stocked at the spare parts centers.
 Components marked X and R are not designated as spare parts for after sales service, and will not be stocked at the spare parts centers.

UNIT-NAME	! C	REF-NO	PARTS-NO	PARTS-NAME	SUFFIX&MODEL
					CX-LEM52 EZSC
FRONT	X R	0344	88-108-563-08	C-RES,56K-1/16W J	a
FRONT	X R	0345	88-108-101-08	C-RESISTOR,1/16W 100	a
FRONT	X R	0351	88-108-222-08	C-RESISTOR, 1/16W 2.2K	a
FRONT	X R	0352	88-121-222-08	RESISTOR, 1/8W 2.2K	a
FRONT	X R	0353	88-108-222-08	C-RESISTOR, 1/16W 2.2K	a
FRONT	O R	0370	87-022-365-08	C-RESISTOR, 1/10W 100K	a
FRONT	X R	0371	88-108-224-08	C-RES,U 220K-1/16W J	a
FRONT	X R	0372	88-108-333-08	C-RESISTOR, 1/16W 33K	a
FRONT	X R	0373	88-108-153-08	C-RES,U 15K-1/16W J	a
FRONT	X R	0374	88-108-103-08	C-RESISTOR, 1/16W 10K	a
FRONT	X R	0375	88-108-224-08	C-RES,U 220K-1/16W J	a
FRONT	X R	0377	88-108-101-08	C-RESISTOR,1/16W 100	a
FRONT	X R	0380	88-108-103-08	C-RES, 1/16W 10K	a
FRONT	X R	0390	88-121-102-08	RES 1/8W 1K	a
FRONT	X R	0391	88-121-101-08	RES 1/8W 100	a
FRONT	X R	0392	88-108-102-08	C-RES, 1/16W 1K	a
FRONT	X R	0393	88-108-101-08	C-RES, 1/16W 100	a
FRONT	X R	0396	88-128-473-08	C-RESISTOR, 1/8W 47K	a
FRONT	X R	0397	88-121-473-08	RESISTOR, 1/8W 47K	a
FRONT	X R	0399	88-121-103-08	RESISTOR, 1/8W 10K	a
					CX-LEM52 EZSC
FRONT	X R	0503	88-108-104-08	C-RESISTOR, 1/16W 100K	a
FRONT	X R	0504	88-108-104-08	C-RESISTOR, 1/16W 100K	a
FRONT	X R	0505	88-108-104-08	C-RESISTOR, 1/16W 100K	a
FRONT	X R	0506	88-108-104-08	C-RESISTOR, 1/16W 100K	a
FRONT	X R	0507	88-108-104-08	C-RESISTOR, 1/16W 100K	a
FRONT	X R	0508	88-108-104-08	C-RESISTOR, 1/16W 100K	a
FRONT	X R	0509	88-108-104-08	C-RESISTOR, 1/16W 100K	a
FRONT	X R	0510	88-108-104-08	C-RESISTOR, 1/16W 100K	a
FRONT	X R	0511	88-108-104-08	C-RESISTOR, 1/16W 100K	a
FRONT	X R	0512	88-108-104-08	C-RESISTOR, 1/16W 100K	a
FRONT	X R	0513	88-108-104-08	C-RESISTOR, 1/16W 100K	a
FRONT	X R	0514	88-108-104-08	C-RESISTOR, 1/16W 100K	a
FRONT	X R	0515	88-108-104-08	C-RESISTOR, 1/16W 100K	a
FRONT	X R	0516	88-108-104-08	C-RESISTOR, 1/16W 100K	a
FRONT	X R	0517	88-108-104-08	C-RESISTOR, 1/16W 100K	a
FRONT	X R	0518	88-108-104-08	C-RESISTOR, 1/16W 100K	a
FRONT	X R	0519	88-108-104-08	C-RESISTOR, 1/16W 100K	a
FRONT	X R	0520	88-108-104-08	C-RESISTOR, 1/16W 100K	a
FRONT	X R	0530	88-108-104-08	C-RESISTOR, 1/16W 100K	a
FRONT	X R	0531	88-108-104-08	C-RESISTOR, 1/16W 100K	a
					CX-LEM52 EZSC
FRONT	X R	0532	88-108-104-08	C-RESISTOR, 1/16W 100K	a
FRONT	X R	0533	88-108-104-08	C-RESISTOR, 1/16W 100K	a
FRONT	X R	0534	88-108-104-08	C-RESISTOR, 1/16W 100K	a
FRONT	X R	0535	88-108-104-08	C-RESISTOR, 1/16W 100K	a
FRONT	X R	0536	88-108-104-08	C-RESISTOR, 1/16W 100K	a
FRONT	X R	0537	88-108-104-08	C-RESISTOR, 1/16W 100K	a
FRONT	X R	0538	88-108-104-08	C-RESISTOR, 1/16W 100K	a
FRONT	X R	0539	88-108-104-08	C-RESISTOR, 1/16W 100K	a
FRONT	X R	0540	88-108-104-08	C-RESISTOR, 1/16W 100K	a
FRONT	X R	0541	88-108-153-08	C-RESISTOR, 1/16W 15K	a
FRONT	X R	0542	88-108-104-08	C-RESISTOR, 1/16W 100K	a
FRONT	X R	151B	88-108-104-08	C-RESISTOR, 1/16W 100K	a
FRONT	X R	303B	88-108-102-08	C-RESISTOR, 1/16W 1K	a
FRONT	X R	304B	88-108-102-08	C-RESISTOR, 1/16W 1K	a
FRONT	X R	305B	88-108-102-08	C-RESISTOR, 1/16W 1K	a
KEY	O C	0045	87-012-286-08	C-CAP, U 0.01-25	a
KEY	O C	0046	87-012-286-08	C-CAP, U 0.01-25	a
KEY	O C	0338	87-A11-155-08	CAP, U 0.01-16	a
KEY	O C	0339	87-A11-155-08	CAP, U 0.01-16	a
KEY	O CN	0003	87-A60-081-01	CONN 6P V FE	a
					CX-LEM52 EZSC
KEY	O CN	501A	S1-2P5-010-70	CONN ASSY 5P UL1007#24	a
KEY	O J	0231	87-099-816-01	JACK,3.5 ST	a
KEY	O L	0001	87-005-849-08	FIXED INDUCTOR 10UH CECSS	a
KEY	O	LED0301	87-A40-317-08	LED,SLR-342VCT31 RED	a
KEY	X R	0045	88-108-682-08	C-RESISTOR, U 6.8K 1/16W J	a
KEY	X R	0046	88-108-123-08	C-RESISTOR,1/16W 12K	a
KEY	X R	0047	88-108-682-08	C-RESISTOR, U 6.8K 1/16W J	a
KEY	X R	0231	88-130-221-08	RES,220-1/4W J	a
KEY	X R	0232	88-130-221-08	RES,220-1/4W J	a
KEY	X R	0248	88-130-221-08	RES,220-1/4W J	a
KEY	X R	0255	88-130-221-08	RES,220-1/4W J	a
KEY	X R	0326	88-108-123-08	C-RES,U 12K-1/16W J	a
KEY	X R	0329	88-108-392-08	C-RES,U 3.9K-1/16W J	a
KEY	X R	0330	88-108-392-08	C-RES,U 3.9K-1/16W J	a
KEY	X R	0331	88-108-272-08	C-RESISTOR, 1/16W 2.7K	a
KEY	X R	0332	88-108-272-08	C-RESISTOR, 1/16W 2.7K	a
KEY	X R	0333	88-108-182-08	C-RES,U 1.8K-1/16W J	a
KEY	X R	0334	88-108-182-08	C-RES,U 1.8K-1/16W J	a
KEY	X R	0335	88-108-152-08	C-RES 1.5K-1/16W	a
KEY	X R	0336	88-108-152-08	C-RES 1.5K-1/16W	a

! = Δ SAFETY PARTS
 C = Components marked

All components used on this model at the production line are shown in this service manual.
 However, please note that not all components will be available as spare parts for after-sales service.
 Components marked S and O are designated as spare parts for service and will be stocked at the spare parts centers.
 Components marked X and R are not designated as spare parts for after sales service, and will not be stocked at the spare parts centers.

UNIT-NAME	! C	REF-NO	PARTS-NO	PARTS-NAME	SUFFIX&MODEL
					CX-LEM52 EZSC
KEY	X R	0346	88-108-103-08	C-RES,U 10K-1/16W J	a
KEY	X R	0347	88-108-223-08	C-RESISTOR, 1/16W 22K	a
KEY	X R	0348	88-108-103-08	C-RES,U 10K-1/16W J	a
KEY	X R	0349	88-108-103-08	C-RES,U 10K-1/16W J	a
KEY	X R	0394	88-108-272-08	C-RESISTOR, 1/16W 2.7K	a
KEY	O S	0301	87-A91-704-08	SW,TACT EVQ21405R	a
KEY	O S	0302	87-A91-704-08	SW,TACT EVQ21405R	a
KEY	O S	0303	87-A91-704-08	SW,TACT EVQ21405R	a
KEY	O S	0304	87-A91-704-08	SW,TACT EVQ21405R	a
KEY	O S	0305	87-A91-704-08	SW,TACT EVQ21405R	a
KEY	O S	0306	87-A91-704-08	SW,TACT EVQ21405R	a
KEY	O S	0307	87-A91-704-08	SW,TACT EVQ21405R	a
KEY	O S	0308	87-A91-704-08	SW,TACT EVQ21405R	a
KEY	O S	0309	87-A91-704-08	SW,TACT EVQ21405R	a
KEY	O S	0310	87-A91-704-08	SW,TACT EVQ21405R	a
KEY	O S	0311	87-A91-704-08	SW,TACT EVQ21405R	a
KEY	O S	0312	87-A91-704-08	SW,TACT EVQ21405R	a
KEY	O S	0313	87-A91-704-08	SW,TACT EVQ21405R	a
KEY	O S	0314	87-A91-704-08	SW,TACT EVQ21405R	a
KEY	O S	0351	87-A92-291-01	SW,RTRY JOG RE121 PVB25FINB1-24a	a
					CX-LEM52 EZSC
MAIN	O C	0001	87-010-263-08	CAP, ELECT 100-10V	a
MAIN	O C	0002	87-010-263-08	CAP, ELECT 100-10V	a
MAIN	O C	0003	87-012-199-08	C-CAP, 220P-50 J	a
MAIN	O C	0004	87-010-759-08	C-CAP, U 0.1-25F	a
MAIN	O C	0005	87-012-280-08	C-CAP, U 3300P-50	a
MAIN	O C	0008	87-010-404-08	CAP-E, 4.7-50V	a
MAIN	O C	0010	87-010-260-08	CAP,E 47-25M 11L SME	a
MAIN	O C	0012	87-010-260-08	CAP,E 47-25M 11L SME	a
MAIN	O C	0013	87-012-286-08	C-CAP, U 0.01-25	a
MAIN	O C	0014	87-010-260-08	CAP,E 47-25M 11L SME	a
MAIN	O C	0015	87-A10-039-08	C-CAP,U 470P-50	a
MAIN	O C	0016	87-010-374-08	CAP, E 47-10M 11L SME	a
MAIN	O C	0017	87-010-403-08	CAP, E 3.3-50M 11L SME	a
MAIN	O C	0018	87-010-247-08	CAP,E 100-50V	a
MAIN	O C	0019	87-010-260-08	CAP,E 47-25M 11L SME	a
MAIN	O C	0020	87-010-260-08	CAP,E 47-25M 11L SME	a
MAIN	O C	0021	87-010-260-08	CAP,E 47-25M 11L SME	a
MAIN	O C	0022	87-010-260-08	CAP,E 47-25M 11L SME	a
MAIN	O C	0023	87-012-368-08	C-CAP 0.1UF-50V Z CER	a
MAIN	O C	0024	87-012-368-08	C-CAP 0.1UF-50V Z CER	a
					CX-LEM52 EZSC
MAIN	O C	0025	87-A10-303-08	CAP 0.047UF J POLY F 50V	a
MAIN	O C	0026	87-A10-303-08	CAP 0.047UF J POLY F 50V	a
MAIN	O C	0027	87-A12-440-00	CAP-E, 3300-35V	a
MAIN	O C	0028	87-016-051-09	CAP-E, 2200-35V	a
MAIN	O C	0029	87-012-282-08	C-CAP, U 4700P-50	a
MAIN	O C	0030	87-012-274-08	C-CAP, U 1000P-50B	a
MAIN	O C	0031	87-012-199-08	C-CAP, 220P-50 J	a
MAIN	O C	0032	87-012-199-08	C-CAP, 220P-50 J	a
MAIN	O C	0033	87-010-404-08	CAP-E, 4.7-50V	a
MAIN	O C	0034	87-010-553-08	CAP 47UF M ELECT 16V	a
MAIN	O C	0035	87-012-286-08	C-CAP, U 0.01-25	a
MAIN	O C	0036	87-012-286-08	C-CAP, U 0.01-25	a
MAIN	O C	0037	87-012-278-08	C-CAP, U 2200P-50	a
MAIN	O C	0038	87-012-278-08	C-CAP, U 2200P-50	a
MAIN	O C	0039	87-010-112-08	ELECT CAP 100-16V	a
MAIN	O C	0101	87-010-387-08	CAP,E 470-25	a
MAIN	O C	0112	87-010-263-08	CAP, ELECT 100-10V	a
MAIN	O C	0140	87-012-274-08	CHIP CAP,U 1000P-50B	a
MAIN	O C	0151	87-010-759-08	C-CAP,U, 0.1-25F	a
MAIN	O C	0208	87-010-404-08	CAP, ELECT 4.7-50V	a
					CX-LEM52 EZSC
MAIN	O C	0214	87-010-260-08	CAP,E 47-25M 11L SME	a
MAIN	O C	0215	87-012-199-08	C-CAP 220P-50 J	a
MAIN	O C	0216	87-012-199-08	C-CAP 220P-50 J	a
MAIN	O C	0217	87-010-959-08	CHIP CAP,U 0.056-16F	a
MAIN	O C	0218	87-010-959-08	CHIP CAP,U 0.056-16F	a
MAIN	O C	0219	87-010-759-08	C-CAP,U, 0.1-25F	a
MAIN	O C	0220	87-010-759-08	C-CAP,U, 0.1-25F	a
MAIN	O C	0221	87-012-287-08	C-CAP,U 0.015-25 F	a
MAIN	O C	0222	87-012-287-08	C-CAP,U 0.015-25 F	a
MAIN	O C	0223	87-010-759-08	C-CAP,U, 0.1-25F	a
MAIN	O C	0224	87-010-759-08	C-CAP,U, 0.1-25F	a
MAIN	O C	0227	87-012-282-08	C-CAP, U 4700P-50	a
MAIN	O C	0235	87-012-286-08	C-CAP, U 0.01-25	a
MAIN	O C	0236	87-012-286-08	C-CAP, U 0.01-25	a
MAIN	O C	0238	87-012-278-08	C-CAP,U 2200P-50 B	a
MAIN	O C	0271	87-012-285-08	C-CAP, U 8200P-50	a
MAIN	O C	0272	87-012-285-08	C-CAP, U 8200P-50	a
MAIN	O C	0274	87-012-195-08	C-CAP,U 100P-50CH	a
MAIN	O C	0275	87-012-195-08	C-CAP,U 100P-50CH	a
MAIN	O C	0450	87-010-759-08	C-CAP,U, 0.1-25F	a

! = Δ SAFETY PARTS
 C = Components marked

All components used on this model at the production line are shown in this service manual.
 However, please note that not all components will be available as spare parts for after-sales service.
 Components marked S and O are designated as spare parts for service and will be stocked at the spare parts centers.
 Components marked X and R are not designated as spare parts for after sales service, and will not be stocked at the spare parts centers.

UNIT-NAME	! C	REF-NO	PARTS-NO	PARTS-NAME	SUFFIX&MODEL
					CX-LEM52 EZSC
MAIN	O C	0451	87-010-759-08	C-CAP, U 0.1-25F	a
MAIN	O C	0452	87-010-248-08	CAP, ELECT 220-10V	a
MAIN	O C	0453	87-012-279-08	C-CAP,U 2700P-50 B	a
MAIN	O C	0454	87-012-279-08	C-CAP,U 2700P-50 B	a
MAIN	O C	0455	87-012-279-08	C-CAP,U 2700P-50 B	a
MAIN	O C	0456	87-012-286-08	C-CAP, U 0.01-25	a
MAIN	O C	0457	87-A12-361-08	CAP,M 5600P-100 J	a
MAIN	O C	0458	87-012-275-08	C-CAP, 1200P-50V J	a
MAIN	O C	0459	87-012-271-08	C-CAP, U 560P-50 K B	a
MAIN	O C	0461	87-012-269-08	C-CAP,U 390P-50 B	a
MAIN	O C	0462	87-012-269-08	C-CAP,U 390P-50 B	a
MAIN	O C	0601	87-012-275-08	C-CAP,U 1200P-50 B	a
MAIN	O C	0602	87-012-275-08	C-CAP,U 1200P-50 B	a
MAIN	O C	0604	87-012-280-08	C-CAP, U 3300P-50	a
MAIN	O C	0611	87-010-545-08	CAP, ELECT 0.22-50V	a
MAIN	O C	0612	87-010-545-08	CAP, ELECT 0.22-50V	a
MAIN	O C	0613	87-010-400-08	CAP, ELECT 0.47-50V	a
MAIN	O C	0614	87-010-400-08	CAP, ELECT 0.47-50V	a
MAIN	O C	0615	87-012-172-08	CAPACITOR CHIP U 10P CH	a
MAIN	O C	0616	87-010-408-08	CAP, ELECT 47-50V	a
					CX-LEM52 EZSC
MAIN	O C	0617	87-010-408-08	CAP, ELECT 47-50V	a
MAIN	O C	0619	87-010-404-08	CAP, ELECT 4.7-50V	a
MAIN	O C	0620	87-010-404-08	CAP, ELECT 4.7-50V	a
MAIN	O C	0627	87-012-286-08	C-CAP, U 0.01-25	a
MAIN	O C	0628	87-012-286-08	C-CAP, U 0.01-25	a
MAIN	O C	0637	87-012-188-08	C-CAP,U 47P-50 CH	a
MAIN	O C	0638	87-012-188-08	C-CAP,U 47P-50 CH	a
MAIN	O C	0639	87-A10-039-08	C-CAP, U 470P-50	a
MAIN	O C	0640	87-A10-039-08	C-CAP, U 470P-50	a
MAIN	O C	0641	87-012-284-08	C-CAP, U 6800P-50	a
MAIN	O C	0642	87-012-284-08	C-CAP, U 6800P-50	a
MAIN	O C	0643	87-010-374-08	CAP, E 47-10M 11L SME	a
MAIN	O C	0644	87-010-374-08	CAP, E 47-10M 11L SME	a
MAIN	O C	0645	87-012-286-08	C-CAP, U 0.01-25	a
MAIN	O C	0646	87-012-286-08	C-CAP, U 0.01-25	a
MAIN	O C	0647	87-012-284-08	C-CAP, U 6800P-50	a
MAIN	O C	0648	87-012-284-08	C-CAP, U 6800P-50	a
MAIN	O C	0649	87-012-198-08	C-CAP, U180P-50	a
MAIN	O C	0650	87-012-198-08	C-CAP, U180P-50	a
MAIN	O C	0651	87-010-402-08	CAP, ELECT 2.2-50V	a
					CX-LEM52 EZSC
MAIN	O C	0652	87-010-402-08	CAP, ELECT 2.2-50V	a
MAIN	O C	0663	87-A11-148-08	CAP, U 0.1-50	a
MAIN	O C	0670	87-010-759-08	C-CAP,U, 0.1-25F	a
MAIN	O C	0703	87-012-275-08	C-CAP,U 1200P-50 B	a
MAIN	O C	0704	87-012-275-08	C-CAP,U 1200P-50 B	a
MAIN	O C	0705	87-012-282-08	C-CAP, U 4700P-50	a
MAIN	O C	0869	87-012-286-08	C-CAP, U 0.01-25	a
MAIN	O C	0870	87-012-274-08	CHIP CAP,U 1000P-50B	a
MAIN	O C	0871	87-012-199-08	C-CAP 220P-50J	a
MAIN	O C	0872	87-012-199-08	C-CAP 220P-50J	a
MAIN	O C	0873	87-012-270-08	CAP, U 470P-50	a
MAIN	O C	0874	87-010-405-08	CAP, ELECT 10-50V	a
MAIN	O C	0875	87-010-759-08	C-CAP,U, 0.1-25F	a
MAIN	O C	0876	87-010-405-08	CAP, ELECT 10-50V	a
MAIN	O C	0877	87-012-286-08	C-CAP, U 0.01-25	a
MAIN	O C	0878	87-012-184-08	C-CAP,U 33P-50 CH	a
MAIN	O C	0879	87-012-180-08	C-CAP,U 22P-50 CH	a
MAIN	O CNA	0101	8A-NF8-655-01	7P CONN ASSY, TID-A(250)	a
MAIN	O CN	0351	87-A60-624-01	CONN,7P V 2MM JMT	a
MAIN	O CN	0501	87-A60-082-01	SOCKET CONN 5PINS	a
					CX-LEM52 EZSC
MAIN	O CN	0502	87-099-752-01	CONN 21P H FFC / FPC	a
MAIN	O CN	0601	87-A60-131-01	CONN 6P V FE	a
MAIN	O CN	0702	87-A60-189-01	CONN,16P V TUC-P16P-B1	a
MAIN	O CON	0351	88-CL4-701-01	CONN ASSY,7P RPEH	a
MAIN	S D	0001	87-020-465-08	DIODE 1SS133 (110MA)	a
MAIN	S D	0002	87-A40-553-08	DIODE 1N4003	a
MAIN	S D	0003	87-A40-393-09	DIODE 1N5402GW	a
MAIN	S D	0004	87-A40-393-09	DIODE 1N5402GW	a
MAIN	S D	0005	87-A40-393-09	DIODE 1N5402GW	a
MAIN	S D	0006	87-A40-393-09	DIODE 1N5402GW	a
MAIN	S D	0100	87-A40-270-08	C-DIODE,MC2838	a
MAIN	S D	0106	87-A40-553-08	DIODE,1N4003	a
MAIN	S D	0107	87-070-150-08	ZENER DIODE MTZJ33D	a
MAIN	S D	0108	87-020-465-08	DIODE,1SS133 (110MA)	a
MAIN	S D	0109	87-A40-269-08	C-DIODE,MC2838	a
MAIN	S D	0110	87-A40-764-08	ZENER,UZ10BSC	a
MAIN	X D	0111	88-121-123-08	RESISTOR, 1/8W-12K	a
MAIN	S D	0116	87-A40-553-08	DIODE,1N4003	a
MAIN	S D	0117	87-A40-553-08	DIODE,1N4003	a
MAIN	S D	0171	87-020-465-08	DIODE,1SS133 (110MA)	a

! = Δ SAFETY PARTS
 C = Components marked

All components used on this model at the production line are shown in this service manual.
 However, please note that not all components will be available as spare parts for after-sales service.
 Components marked S and O are designated as spare parts for service and will be stocked at the spare parts centers.
 Components marked X and R are not designated as spare parts for after sales service, and will not be stocked at the spare parts centers.

UNIT-NAME	! C	REF-NO	PARTS-NO	PARTS-NAME	SUFFIX&MODEL
					CX-LEM52 EZSC
MAIN	S D	0201	87-A40-269-08	C-DIODE,MC2836	a
MAIN	S D	0202	87-A40-270-08	C-DIODE,MC2838	a
MAIN	S D	0203	87-A40-269-08	C-DIODE,MC2836	a
MAIN	S D	0204	87-A40-269-08	C-DIODE,MC2836	a
MAIN	S D	0205	87-A40-270-08	C-DIODE,MC2838	a
MAIN	S D	0206	87-A40-270-08	C-DIODE,MC2838	a
MAIN	S D	0207	87-A40-270-08	C-DIODE,MC2838	a
MAIN	S D	0208	87-A40-270-08	C-DIODE,MC2838	a
MAIN	S D	0209	87-A40-270-08	C-DIODE,MC2838	a
MAIN	S D	0601	87-A40-745-08	ZENER,UZ4.7BSA	a
MAIN	S D	0602	87-A40-745-08	ZENER,UZ4.7BSA	a
MAIN	S D	0702	87-020-465-08	DIODE,1SS133 (110MA)	a
MAIN	O FB	0110	83-XM1-617-08	C-COIL BK2125HM601	a
MAIN	O FB	0111	83-XM1-617-08	C-COIL BK2125HM601	a
MAIN	O FB	0601	S1-8A8-435-56	F-BEAD 843556 TB36	a
MAIN	O FB	0602	S1-8A8-435-56	F-BEAD 843556 TB36	a
MAIN	O FB	0603	S1-8A8-435-56	F-BEAD 843556 TB36	a
MAIN	O FFC	0601	88-906-131-11	FF-CABLE,6P	a
MAIN	S IC	0102	87-A21-786-01	IC, KIA7806API	a
MAIN	S IC	0601	87-A22-236-04	C-IC, BD3881FV	a
					CX-LEM52 EZSC
MAIN	S IC	0801	87-A20-440-08	C-IC,BU1920FS	a
MAIN	O J	0241	87-A60-217-01	TERMINAL,SPKR 4P	a
MAIN	O J	0601	87-A60-881-01	JACK,PIN 2P MSP 242V05 PBSN	a
MAIN	O J	0603	87-099-801-01	JACK,PIN 1P BLK	a
MAIN	O JR	0617	83-XM1-617-08	C-COIL BK2125HM601	a
MAIN	O JR	0618	S1-8A8-435-56	F-BEAD 843556 TB36	a
MAIN	X JW	0001	88-121-229-08	RES 2.2 J C 1/8W	a
MAIN	O L	0201	87-A50-610-01	COIL,1UH K(MDEC)	a
MAIN	O L	0202	87-A50-610-01	COIL,1UH K(MDEC)	a
MAIN	O L	0451	87-007-342-01	COIL,OSC 85K BIAS	a
MAIN	O L	0861	87-005-847-08	COIL,2.2UH	a
MAIN	O PN	0101	8C-CL5-609-01	CONN ASSY 07P	a
MAIN	S O	0002	89-111-625-08	C-TR,2SA1162GR	a
MAIN	S Q	0004	89-111-625-08	C-TR,2SA1162GR	a
MAIN	S Q	0005	87-A30-387-04	C-TR,DTA124EUA	a
MAIN	S Q	0100	89-327-125-08	C-TR,2SC2712GR	a
MAIN	S Q	0102	87-A30-630-08	TR,2SC5343GL	a
MAIN	S Q	0103	87-A30-076-08	C-TR,2SC3052	a
MAIN	S Q	0104	87-A30-494-08	TR,2SA1980G	a
MAIN	S Q	0105	87-A30-515-08	TR,2SA19790/Y	a
					CX-LEM52 EZSC
MAIN	S Q	0106	89-327-125-08	C-TR,2SC2712GR	a
MAIN	S Q	0107	89-327-125-08	C-TR,2SC2712GR	a
MAIN	S Q	0108	89-111-625-08	C-TR,2SA1162GR	a
MAIN	S Q	0109	89-327-125-08	C-TR,2SC2712GR	a
MAIN	S Q	0110	89-111-625-08	C-TR,2SA1162GR	a
MAIN	S Q	0111	89-213-702-01	TR,2SB1370 (30W)	a
MAIN	S Q	0112	89-327-125-08	C-TR,2SC2712GR	a
MAIN	S Q	0202	89-111-625-08	C-TR,2SA1162GR	a
MAIN	S Q	0203	89-111-625-08	C-TR,2SA1162GR	a
MAIN	S Q	0204	89-111-625-08	C-TR,2SA1162GR	a
MAIN	S Q	0205	89-327-125-08	C-TR,2SC2712GR	a
MAIN	S Q	0206	89-327-125-08	C-TR,2SC2712GR	a
MAIN	S Q	0207	89-327-125-08	C-TR,2SC2712GR	a
MAIN	S Q	0208	89-327-125-08	C-TR,2SC2712GR	a
MAIN	S Q	0209	87-A30-630-08	TR,2SC5343GL	a
MAIN	S Q	0210	87-A30-630-08	TR,2SC5343GL	a
MAIN	S Q	0211	87-A30-256-01	TR,2SD1933	a
MAIN	S Q	0212	87-A30-256-01	TR,2SD1933	a
MAIN	S Q	0213	87-A30-255-01	TR,2SB1342	a
MAIN	S Q	0214	87-A30-255-01	TR,2SB1342	a
					CX-LEM52 EZSC
MAIN	S Q	0215	89-111-625-08	C-TR,2SA1162GR	a
MAIN	S Q	0216	89-111-625-08	C-TR,2SA1162GR	a
MAIN	S Q	0217	87-A30-494-04	TR,2SA1980G	a
MAIN	S Q	0218	89-327-125-08	C-TR,2SC2712GR	a
MAIN	S Q	0219	87-A30-630-08	TR,2SC5343GL	a
MAIN	S Q	0220	87-A30-630-08	TR,2SC5343GL	a
MAIN	S Q	0221	87-A30-630-08	TR,2SC5343GL	a
MAIN	S Q	0222	87-A30-630-08	TR,2SC5343GL	a
MAIN	S Q	0223	89-327-125-08	C-TR,2SC2712GR	a
MAIN	S Q	0224	89-327-125-08	C-TR,2SC2712GR	a
MAIN	S Q	0225	89-327-125-08	C-TR,2SC2712GR	a
MAIN	S Q	0226	89-327-125-08	C-TR,2SC2712GR	a
MAIN	S Q	0261	89-327-125-08	C-TR,2SC2712GR	a
MAIN	S Q	0262	89-327-125-08	C-TR,2SC2712GR	a
MAIN	S Q	0263	89-111-625-08	C-TR,2SA1162GR	a
MAIN	S Q	0305	87-A30-087-08	C-FET,2SK2158	a
MAIN	S Q	0306	87-A30-387-04	C-TR,DTA124EUA	a
MAIN	S Q	0307	87-A30-087-08	C-FET,2SK2158	a
MAIN	S Q	0308	87-A30-087-08	C-FET,2SK2158	a
MAIN	S Q	0309	89-111-625-08	C-TR,2SA1162GR	a

! = Δ SAFETY PARTS
 C = Components marked

All components used on this model at the production line are shown in this service manual.
 However, please note that not all components will be available as spare parts for after-sales service.
 Components marked S and O are designated as spare parts for service and will be stocked at the spare parts centers.
 Components marked X and R are not designated as spare parts for after sales service, and will not be stocked at the spare parts centers.

UNIT-NAME	! C	REF-NO	PARTS-NO	PARTS-NAME	SUFFIX&MODEL
					CX-LEM52 EZSC
MAIN	S Q	0450	87-A30-076-08	C-TR,2SC3052	a
MAIN	S Q	0451	87-A30-630-08	TR,2SC5343GL	a
MAIN	S Q	0452	87-A30-087-04	C-FET,2SK2158	a
MAIN	S Q	0453	87-A30-630-08	TR,2SC5343GL	a
MAIN	S Q	0454	87-A30-630-08	TR,2SC5343GL	a
MAIN	S Q	0861	89-327-125-08	C-TR,2SC2712GR	a
MAIN	S Q	0863	87-A30-540-04	C-TR,2SC2712GR	a
MAIN	X R	0001	88-121-270-08	RES, 1/8W 2.7	a
MAIN	X R	0002	88-108-393-08	C-RESISTOR, 1/16W 39k	a
MAIN	X R	0011	88-108-472-08	C-RESISTOR, 1/16W 4.7K	a
MAIN	X R	0012	88-108-472-08	C-RESISTOR, 1/16W 4.7K	a
MAIN	X R	0013	88-108-101-08	C-RESISTOR,1/16W 100	a
MAIN	X R	0016	88-108-221-08	C-RES, U 220 1/16W J	a
MAIN	X R	0017	88-108-471-08	C-RESISTOR, 1/16W 470	a
MAIN	X R	0021	88-108-472-08	C-RESISTOR, 1/16W 4.7K	a
MAIN	X R	0024	88-108-104-08	C-RESISTOR,1/16W 100K	a
MAIN	X R	0025	88-108-100-08	C-RES,U 10-1/16W J	a
MAIN	X R	0026	88-108-472-08	C-RESISTOR, 1/16W 4.7K	a
MAIN	X R	0027	88-108-472-08	C-RESISTOR, 1/16W 4.7K	a
MAIN	X R	0028	88-121-273-08	RES,1/8W 27K	a
					CX-LEM52 EZSC
MAIN	X R	0029	88-121-273-08	RES,1/8W 27K	a
MAIN	X R	0030	88-121-109-08	RES 1 J C 1/8W	a
MAIN	X R	0031	88-108-109-08	C-RES,U 1 1/16W J	a
MAIN	X R	0032	88-108-109-08	C-RES,U 1 1/16W J	a
MAIN	X R	0033	88-121-109-08	RES 1 J C 1/8W	a
MAIN	X R	0034	88-108-100-08	C-RES,U 10-1/16W J	a
MAIN	X R	0035	88-108-103-08	C-RESISTOR, 1/16W 10K	a
MAIN	X R	0036	88-118-390-08	C-RES,S 39-1/10W J	a
MAIN	X R	0037	88-108-472-08	C-RESISTOR, 1/16W 4.7K	a
MAIN	X R	0038	88-108-101-08	C-RESISTOR,1/16W 100	a
MAIN	X R	0039	88-121-472-08	RESISTOR,1/8W 4.7K	a
MAIN	X R	0040	88-108-103-08	C-RESISTOR, 1/16W 10K	a
MAIN	X R	0041	88-108-154-08	C-RESISTOR,1/16W 150K	a
MAIN	X R	0042	88-108-103-08	C-RESISTOR, 1/16W 10K	a
MAIN	X R	0043	88-121-103-08	RESISTOR, 1/8W 10K	a
MAIN	X R	0044	88-121-103-08	RESISTOR, 1/8W 10K	a
MAIN	X R	0048	88-108-222-08	C-RESISTOR,1/16W 2.2K	a
MAIN	X R	0049	88-108-222-08	C-RESISTOR,1/16W 2.2K	a
MAIN	X R	0050	88-108-102-08	C-RESISTOR, 1/16W 1K	a
MAIN	X R	0051	88-108-102-08	C-RESISTOR, 1/16W 1K	a
					CX-LEM52 EZSC
MAIN	X R	0104	88-121-471-08	RESISTOR, 1/8W 470	a
MAIN	X R	0105	88-108-823-08	C-RES,U 82K-1/16W J	a
MAIN	X R	0106	88-108-680-08	C-RES,U 68-1/16W J	a
MAIN	X R	0109	88-108-103-08	C-RESISTOR, 1/16W 10K	a
MAIN	X R	0133	88-108-123-08	RESISTOR, 1/16W 12K	a
MAIN	X R	0134	88-121-104-08	RESISTOR, 1/8W 100K	a
MAIN	X R	0135	88-108-472-08	C-RESISTOR, 1/16W 4.7K	a
MAIN	X R	0136	88-108-472-08	C-RESISTOR, 1/16W 4.7K	a
MAIN	X R	0201	88-108-473-08	C-RESISTOR, 1/16W 47K	a
MAIN	X R	0202	88-108-473-08	C-RESISTOR, 1/16W 47K	a
MAIN	X R	0204	88-108-103-08	C-RESISTOR, 1/16W 10K	a
MAIN	X R	0205	88-118-390-08	C-RES,S 39-1/10W J	a
MAIN	X R	0207	88-108-223-08	C-RESISTOR, 1/16W 22K	a
MAIN	X R	0208	88-108-223-08	C-RESISTOR, 1/16W 22K	a
MAIN	X R	0209	88-108-101-08	C-RESISTOR,1/16W 100	a
MAIN	X R	0210	88-108-101-08	C-RESISTOR,1/16W 100	a
MAIN	X R	0215	88-108-103-08	C-RESISTOR, 1/16W 10K	a
MAIN	X R	0216	88-121-103-08	RESISTOR, 1/8W 10K	a
MAIN	X R	0217	88-108-223-08	C-RESISTOR, 1/16W 22K	a
MAIN	X R	0218	88-108-223-08	C-RESISTOR, 1/16W 22K	a
					CX-LEM52 EZSC
MAIN	X R	0219	88-121-102-08	RES 1K-1/8W	a
MAIN	X R	0220	88-121-102-08	RES 1K-1/8W	a
MAIN	X R	0221	88-121-102-08	RES 1K-1/8W	a
MAIN	X R	0222	88-121-102-08	RES 1K-1/8W	a
MAIN	O R	0223	87-A00-258-08	RES,M/F 0.22-1W J	a
MAIN	O R	0224	87-A00-258-08	RES,M/F 0.22-1W J	a
MAIN	X R	0230	88-108-102-08	C-RESISTOR, 1/16W 1K	a
MAIN	X R	0233	88-121-102-08	RESISTOR, 1/8W 1K	a
MAIN	X R	0234	88-108-102-08	C-RESISTOR, 1/16W 1K	a
MAIN	X R	0235	88-108-103-08	C-RESISTOR, 1/16W 10K	a
MAIN	X R	0236	88-130-100-08	RES, 10-1/4W J	a
MAIN	X R	0237	88-108-104-08	C-RESISTOR, 1/16W 100K	a
MAIN	X R	0238	88-108-104-08	C-RESISTOR, 1/16W 100K	a
MAIN	X R	0239	88-118-390-08	C-RES,S 39-1/10W J	a
MAIN	X R	0240	88-118-390-08	C-RES,S 39-1/10W J	a
MAIN	X R	0241	88-108-101-08	C-RESISTOR,1/16W 100	a
MAIN	X R	0242	88-108-102-08	C-RESISTOR, 1/16W 1K	a
MAIN	X R	0243	88-108-101-08	C-RESISTOR,1/16W 100	a
MAIN	X R	0244	88-121-471-08	RESISTOR, 1/8W 470	a
MAIN	X R	0245	88-108-100-08	C-RES,U 10-1/16W J	a

! = Δ SAFETY PARTS
 C = Components marked

All components used on this model at the production line are shown in this service manual.
 However, please note that not all components will be available as spare parts for after-sales service.
 Components marked S and O are designated as spare parts for service and will be stocked at the spare parts centers.
 Components marked X and R are not designated as spare parts for after sales service, and will not be stocked at the spare parts centers.

UNIT-NAME	! C	REF-NO	PARTS-NO	PARTS-NAME	SUFFIX&MODEL
					CX-LEM52 EZSC
MAIN	X R	0246	88-108-153-08	C-RES,U 15K-1/16W J	a
MAIN	X R	0247	88-108-153-08	C-RES,U 15K-1/16W J	a
MAIN	O R	0249	87-A00-258-08	RES,M/F 0.22-1W J	a
MAIN	O R	0250	87-A00-258-08	RES,M/F 0.22-1W J	a
MAIN	X R	0251	88-108-103-08	C-RESISTOR, 1/16W 10K	a
MAIN	X R	0252	88-108-103-08	C-RESISTOR, 1/16W 10K	a
MAIN	X R	0253	88-108-272-08	C-RESISTOR, 1/16W 2.7K	a
MAIN	X R	0254	88-108-272-08	C-RESISTOR, 1/16W 2.7K	a
MAIN	X R	0256	88-130-100-08	RES,10-1/4W J	a
MAIN	X R	0257	88-108-473-08	C-RESISTOR, 1/16W 47K	a
MAIN	X R	0258	88-108-103-08	C-RESISTOR, 1/16W 10K	a
MAIN	X R	0259	88-108-103-08	C-RESISTOR, 1/16W 10K	a
MAIN	X R	0260	88-108-122-08	C-RES,U 1.2K-1/16W J	a
MAIN	X R	0261	88-108-222-08	C-RESISTOR,1/16W 2.2K	a
MAIN	X R	0262	88-108-222-08	C-RESISTOR,1/16W 2.2K	a
MAIN	X R	0263	88-108-473-08	C-RESISTOR, 1/16W 47K	a
MAIN	X R	0264	88-108-105-08	C-RESISTER 1MS	a
MAIN	X R	0265	88-108-103-08	C-RESISTOR, 1/16W 10K	a
MAIN	X R	0266	88-121-102-08	RESISTOR, 1/8W 1K	a
MAIN	X R	0269	88-108-101-08	C-RESISTOR,1/16W 100	a
					CX-LEM52 EZSC
MAIN	X R	0270	88-108-101-08	C-RESISTOR,1/16W 100	a
MAIN	X R	0271	88-108-122-08	C-RES,U 1.2K-1/16W J	a
MAIN	X R	0273	88-108-561-08	C-RESISTOR, 1/16W 560	a
MAIN	X R	0274	88-108-561-08	C-RESISTOR, 1/16W 560	a
MAIN	X R	0275	88-108-122-08	C-RES,U 1.2K-1/16W J	a
MAIN	X R	0276	88-108-122-08	C-RES,U 1.2K-1/16W J	a
MAIN	X R	0277	88-108-222-08	C-RESISTOR, 1/16W 2.2K	a
MAIN	X R	0278	88-108-222-08	C-RESISTOR, 1/16W 2.2K	a
MAIN	X R	0281	88-108-562-08	C-RESISTOR, 1/16W 5.6K	a
MAIN	X R	0282	88-108-562-08	C-RESISTOR, 1/16W 5.6K	a
MAIN	X R	0290	88-108-154-08	C-RESISTOR, 1/16W 150K	a
MAIN	X R	0291	88-108-154-08	C-RESISTOR, 1/16W 150K	a
MAIN	X R	0292	88-108-822-08	C-RESISTOR, 1/16W 8.2K	a
MAIN	X R	0325	88-108-105-08	C-RESISTER 1MS	a
MAIN	X R	0327	88-121-472-08	RES,U 4.7K-1/8W J	a
MAIN	X R	0328	88-108-392-08	C-RESISTOR, 1/16W 3.9K	a
MAIN	X R	0451	88-121-103-08	RESISTOR, 1/8W 10K	a
MAIN	X R	0452	88-108-103-08	C-RESISTOR, 1/16W 10K	a
MAIN	X R	0453	88-108-222-08	C-RESISTOR, 1/16W 2.2K	a
MAIN	X R	0454	88-130-829-08	RES,U 8.2-1/4W J	a
					CX-LEM52 EZSC
MAIN	X R	0455	88-108-183-08	C-RESISTOR, 1/16W 18K	a
MAIN	X R	0456	88-108-183-08	C-RESISTOR, 1/16W 18K	a
MAIN	X R	0457	88-121-472-08	RESISTOR, 1/8W 4.7K	a
MAIN	X R	0458	88-108-472-08	C-RESISTOR, 1/16W 4.7K	a
MAIN	X R	0459	88-108-563-08	C-RES,U 56K-1/16W J	a
MAIN	X R	0460	88-108-104-08	C-RESISTOR, 1/16W 100K	a
MAIN	X R	0465	88-108-103-08	C-RESISTOR, 1/16W 10K	a
MAIN	X R	0466	88-108-103-08	C-RESISTOR, 1/16W 10K	a
MAIN	X R	0599	88-108-103-08	C-RESISTOR, 1/16W 10K	a
MAIN	X R	0604	88-108-393-08	C-RESISTOR, 1/16W 39K	a
MAIN	X R	0609	88-108-332-08	C-RESISTOR, 1/16W 3.3K	a
MAIN	X R	0610	88-108-332-08	C-RESISTOR, 1/16W 3.3K	a
MAIN	X R	0613	88-108-472-08	C-RESISTOR, 1/16W 4.7K	a
MAIN	X R	0614	88-108-103-08	C-RESISTOR, 1/16W 10K	a
MAIN	X R	0615	88-121-472-08	RESISTOR, 1/8W 4.7K	a
MAIN	X R	0617	88-108-102-08	RESISTOR, 1/16W 1K	a
MAIN	X R	0618	88-108-102-08	RESISTOR, 1/16W 1K	a
MAIN	X R	0619	88-108-102-08	RESISTOR, 1/16W 1K	a
MAIN	X R	0620	88-108-102-08	RESISTOR, 1/16W 1K	a
MAIN	X R	0621	88-108-101-08	C-RESISTOR,1/16W 100	a
					CX-LEM52 EZSC
MAIN	X R	0622	88-130-181-08	RES,180-1/4W J	a
MAIN	X R	0623	88-130-181-08	RES,180-1/4W J	a
MAIN	X R	0624	88-130-471-08	RES,470-1/4W J	a
MAIN	X R	0625	88-108-103-08	C-RESISTOR, 1/16W 10K	a
MAIN	X R	0626	88-108-103-08	C-RESISTOR, 1/16W 10K	a
MAIN	X R	0627	88-108-103-08	C-RESISTOR, 1/16W 10K	a
MAIN	X R	0631	88-108-123-08	C-RESISTOR, 1/16W 12K	a
MAIN	X R	0632	88-108-123-08	C-RESISTOR, 1/16W 12K	a
MAIN	X R	0633	88-108-472-08	C-RESISTOR, 1/16W 4.7K	a
MAIN	X R	0634	88-108-472-08	C-RESISTOR, 1/16W 4.7K	a
MAIN	X R	0635	88-108-820-08	C-RES,U ϵ 2-1/16W J	a
MAIN	X R	0636	88-108-820-08	C-RES,U ϵ 2-1/16W J	a
MAIN	X R	0637	88-108-471-08	C-RESISTOR, 1/16W 470	a
MAIN	X R	0638	88-108-471-08	C-RESISTOR, 1/16W 470	a
MAIN	X R	0639	88-108-272-08	C-RESISTOR, 1/16W 2.7K	a
MAIN	X R	0640	88-108-272-08	C-RESISTOR, 1/16W 2.7K	a
MAIN	X R	0641	88-108-102-08	C-RESISTOR, 1/16W 1K	a
MAIN	X R	0642	88-108-102-08	C-RESISTOR, 1/16W 1K	a
MAIN	X R	0643	88-108-102-08	C-RESISTOR, 1/16W 1K	a
MAIN	X R	0644	88-108-102-08	C-RESISTOR, 1/16W 1K	a

! = Δ SAFETY PARTS
 C = Components marked

All components used on this model at the production line are shown in this service manual.
 However, please note that not all components will be available as spare parts for after-sales service.
 Components marked S and O are designated as spare parts for service and will be stocked at the spare parts centers.
 Components marked X and R are not designated as spare parts for after sales service, and will not be stocked at the spare parts centers.

UNIT-NAME	! C	REF-NO	PARTS-NO	PARTS-NAME	SUFFIX&MODEL
					CX-LEM52 EZSC
MAIN	X R	0645	88-108-103-08	C-RESISTOR, 1/16W 10K	a
MAIN	X R	0646	88-108-103-08	C-RESISTOR, 1/16W 10K	a
MAIN	X R	0647	88-108-182-08	C-RESISTOR, 1/16W 1.8K	a
MAIN	X R	0648	88-108-182-08	C-RESISTOR, 1/16W 1.8K	a
MAIN	X R	0649	88-108-183-08	C-RES,U 18K-1/16W J	a
MAIN	X R	0650	88-121-183-08	RES,U 18K-1/8W J	a
MAIN	X R	0651	88-108-122-08	C-RES,U 1.2K-1/16W J	a
MAIN	X R	0652	88-108-122-08	C-RES,U 1.2K-1/16W J	a
MAIN	X R	0653	88-108-102-08	RESISTOR, 1/16W 1K	a
MAIN	X R	0654	88-108-102-08	RESISTOR, 1/16W 1K	a
MAIN	X R	0655	88-108-183-08	C-RESISTOR, 1/16W 18K	a
MAIN	X R	0656	88-108-183-08	C-RESISTOR, 1/16W 18K	a
MAIN	X R	0657	88-118-394-08	C-RESISTOR, 1/10W 390K	a
MAIN	X R	0658	88-118-394-08	C-RESISTOR, 1/10W 390K	a
MAIN	X R	0694	88-130-471-08	RES,470-1/4W J	a
MAIN	X R	0697	88-130-101-08	RES,100-1/4W J	a
MAIN	X R	0700	88-108-332-08	CHIP RESISTOR SS,3.3K	a
MAIN	X R	0701	88-108-273-08	C-RESISTOR, 1/16W 27K	a
MAIN	X R	0702	88-108-273-08	C-RESISTOR, 1/16W 27K	a
MAIN	X R	0705	88-108-000-08	C-JUMPER,U	a
					CX-LEM52 EZSC
MAIN	X R	0706	88-108-000-08	C-JUMPER,U	a
MAIN	X R	0707	88-121-393-08	RESISTOR, 1/8W 39K	a
MAIN	X R	0709	88-108-225-08	C-RES,U 2.2M-1/16W J	a
MAIN	X R	0861	88-108-471-08	C-RESISTOR, 1/16W 470	a
MAIN	X R	0862	88-121-272-08	RESISTOR, 1/8W 2.7K	a
MAIN	X R	0863	88-108-104-08	C-RESISTOR, 1/16W 100K	a
MAIN	X R	0864	88-108-123-08	C-RESISTOR, 1/16W 12K	a
MAIN	X R	0865	88-108-471-08	C-RESISTOR, 1/16W 470	a
MAIN	X R	0867	88-108-104-08	C-RESISTOR, 1/16W 100K	a
MAIN	X R	0870	88-108-102-08	C-RESISTOR, 1/16W 1K	a
MAIN	X R	0871	88-121-102-08	RESISTOR, 1/8W 1K	a
MAIN	X R	0872	88-108-474-08	C-RES,U 470K-1/16W J	a
MAIN	X R	0906	88-108-683-08	C-RES 68K 1/16W J	a
MAIN	X R	0907	88-108-683-08	C-RES 68K 1/16W J	a
MAIN	X R	0908	88-108-333-08	C-RES 33K 1/16W J	a
MAIN	X R	0909	88-108-102-08	C-RESISTOR, 1/16W 1K	a
MAIN	X W	0105	87-A60-884-01	PIN DIAL,COATING-SHS	a
MAIN	O X	0861	87-A70-091-01	X,TAL,4.332MHZ	a
PT	O C	0101	87-010-387-08	CAP,E 470-25 SME	a
PT	O CN	0101	87-A61-109-01	CONN 07P V TID-A	a
					CX-LEM52 EZSC
PT	S D	0101	87-020-465-08	DIODE,1SS133 (110MA)	a
PT	S D	0102	87-020-465-08	DIODE,1SS133 (110MA)	a
PT	S D	0103	87-020-465-08	DIODE,1SS133 (110MA)	a
PT	S D	0104	87-020-465-08	DIODE,1SS133 (110MA)	a
PT	! O PT	0101	8C-CL5-603-01	PT,EZ	a
PT	! O PT	0102	8B-NF9-665-01	PT,SUB BNF E (TAM)	a
PT	! O RY	0102	87-A91-418-01	RELAY,AC 12V G5 PA-1-M	a
PT	! O T	0101	87-A60-317-01	TERMINAL, 1P MSC	a
PT	! O T	0102	87-A60-317-01	TERMINAL, 1P MSC	a

ELECTRICAL PARTS LIST (CZA – 3)

! = Δ SAFETY PARTS
 C = Components marked

All components used on this model at the production line are shown in this service manual.
 However, please note that not all components will be available as spare parts for after-sales service.
 Components marked S and O are designated as spare parts for service and will be stocked at the spare parts centers.
 Components marked X and R are not designated as spare parts for after sales service, and will not be stocked at the spare parts centers.

UNIT-NAME	! C	REF-NO	PARTS-NO	PARTS-NAME	SUFFIX&MODEL
					CZA-3 EZC
TUNER	O C	0772	87-012-286-080	C-CAP,U 0.01-25 K B GRM	a
TUNER	O C	0781	87-012-286-080	C-CAP,U 0.01-25 K B GRM	a
TUNER	O C	0782	86-ZA1-616-080	C-CAP,U 0.01-50 K B (MUR)	a
TUNER	O C	0783	87-012-286-080	C-CAP,U 0.01-25 K B GRM	a
TUNER	O C	0785	87-012-286-080	C-CAP,U 0.01-25 K B GRM	a
TUNER	O C	0786	87-012-286-080	C-CAP,U 0.01-25 K B GRM	a
TUNER	O C	0788	87-012-167-080	C-CAP,U 5P-50 C CH GRM	a
TUNER	O C	0789	87-A11-228-080	C-CAP,U 0.027-25 K B	a
TUNER	O C	0790	87-A11-228-080	C-CAP,U 0.027-25 K B	a
TUNER	O C	0792	87-012-286-080	C-CAP,U 0.01-25 K B GRM	a
TUNER	O C	0793	87-A10-262-080	C-CAP,U 1-10 Z F	a
TUNER	O C	0795	87-012-286-080	C-CAP,U 0.01-25 K B GRM	a
TUNER	O C	0797	87-012-286-080	C-CAP,U 0.01-25 K B GRM	a
TUNER	O C	0799	87-A12-070-040	CAP,E 33-25 SMG	a
TUNER	O C	0800	87-012-286-080	C-CAP,U 0.01-25 K B GRM	a
TUNER	O C	0801	87-A10-262-080	C-CAP,U 1-10 Z F	a
TUNER	O C	0802	87-010-829-080	C-CAP,U 0.047-16 Z F	a
TUNER	O C	0804	87-A12-062-040	CAP,E 100-10 SMG	a
TUNER	O C	0807	87-A10-463-080	C-CAP,U 0.47-10 Z F	a
TUNER	O C	0808	87-A10-262-080	C-CAP,U 1-10 Z F	a
					CZA-3 EZC
TUNER	O C	0809	87-A10-262-080	C-CAP,U 1-10 Z F	a
TUNER	O C	0814	87-012-286-080	C-CAP,U 0.01-25 K B GRM	a
TUNER	O C	0815	87-A10-463-080	C-CAP,U 0.47-10 Z F	a
TUNER	O C	0816	87-A10-463-080	C-CAP,U 0.47-10 Z F	a
TUNER	O C	0818	87-012-276-080	C-CAP,U 1500P-50 K B GRM	a
TUNER	O C	0821	87-A11-796-080	C-CAP,S 4.7-10 Z F	a
TUNER	O C	0823	87-012-274-080	C-CAP,U 1000P-50 K B GRM	a
TUNER	O C	0824	87-A11-796-080	C-CAP,S 4.7-10 Z F	a
TUNER	O C	0825	87-A11-317-080	C-CAP,U 0.068U-16 K B	a
TUNER	O C	0831	87-A12-069-040	CAP,E 22-25 SMG	a
TUNER	O C	0837	87-A12-022-080	C-CAP,U 0.22-16 Z F	a
TUNER	O C	0842	87-010-831-080	C-CAP,U 0.1-16 Z F	a
TUNER	O C	0850	87-A10-262-080	C-CAP,U 1-10 Z F	a
TUNER	O C	0851	87-012-286-080	C-CAP,U 0.01-25 K B GRM	a
TUNER	O C	0852	87-012-286-080	C-CAP,U 0.01-25 K B GRM	a
TUNER	O C	0853	87-012-286-080	C-CAP,U 0.01-25 K B GRM	a
TUNER	O C	0854	87-012-286-080	C-CAP,U 0.01-25 K B GRM	a
TUNER	O C	0855	87-012-286-080	C-CAP,U 0.01-25 K B GRM	a
TUNER	O C	0856	87-012-286-080	C-CAP,U 0.01-25 K B GRM	a
TUNER	O C	0859	87-010-831-080	C-CAP,U 0.1-16 Z F	a
					CZA-3 EZC
TUNER	O C	0860	87-012-286-080	C-CAP,U 0.01-25 K B GRM	a
TUNER	O C	0901	87-012-162-080	C-CAP,U 1P-50 C CH GRM	a
TUNER	O C	0902	87-012-165-080	C-CAP,U 3P-50 C CH GRM	a
TUNER	O C	0903	87-012-164-080	C-CAP,U 2P-50 C CH GRM	a
TUNER	O C	0904	86-ZA1-615-080	C-CAP,U 680P-25 J CH	a
TUNER	O C	0905	87-012-162-080	C-CAP,U 1P-50 C CH GRM	a
TUNER	O C	0906	87-012-172-080	C-CAP,U 10P-50 D CH GRM	a
TUNER	O C	0907	87-012-166-080	C-CAP,U 4P-50 C CH GRM	a
TUNER	O C	0908	87-012-165-080	C-CAP,U 3P-50 C CH GRM	a
TUNER	O C	0909	86-ZA1-615-080	C-CAP,U 680P-25 J CH	a
TUNER	O C	0910	87-012-164-080	C-CAP,U 2P-50 C CH GRM	a
TUNER	O C	0911	87-012-166-080	C-CAP,U 4P-50 C CH GRM	a
TUNER	O C	0912	87-012-195-080	C-CAP,U 100P-50 J CH GRM	a
TUNER	O C	0913	86-ZA1-616-080	C-CAP,U 0.01-50 K B (MUR)	a
TUNER	O C	0914	86-ZA1-616-080	C-CAP,U 0.01-50 K B (MUR)	a
TUNER	O C	0915	86-ZA1-616-080	C-CAP,U 0.01-50 K B (MUR)	a
TUNER	O C	0916	86-ZA1-616-080	C-CAP,U 0.01-50 K B (MUR)	a
TUNER	O C	0917	87-012-178-080	C-CAP,U 18P-50 J CH GRM	a
TUNER	O C	0918	87-012-172-080	C-CAP,U 10P-50 D CH GRM	a
TUNER	O C	0919	87-012-184-080	C-CAP,U 33P-50 J CH GRM	a
					CZA-3 EZC
TUNER	O C	0920	87-012-184-080	C-CAP,U 33P-50 J CH GRM	a
TUNER	O C	0921	87-012-180-080	C-CAP,U 22P-50 J CH GRM	a
TUNER	O C	0922	87-012-174-080	C-CAP,U 12P-50 J CH GRM	a
TUNER	O C	0923	86-ZA1-616-080	C-CAP,U 0.01-50 K B (MUR)	a
TUNER	O C	0924	87-012-164-080	C-CAP,U 2P-50 C CH GRM	a
TUNER	O C	0925	87-012-164-080	C-CAP,U 2P-50 C CH GRM	a
TUNER	O C	0926	88-108-101-080	C-RES,U 100-1/16W J	a
TUNER	O C	0927	87-012-195-080	C-CAP,U 100P-50 J CH GRM	a
TUNER	O C	0931	87-A12-319-080	C-CAP,U 0.1-25 K B	a
TUNER	O C	0932	87-012-286-080	C-CAP,U 0.01-25 K B GRM	a
TUNER	O C	0933	87-012-286-080	C-CAP,U 0.01-25 K B GRM	a
TUNER	O C	0934	87-012-286-080	C-CAP,U 0.01-25 K B GRM	a
TUNER	O C	0935	87-012-286-080	C-CAP,U 0.01-25 K B GRM	a
TUNER	O C	0936	87-012-286-080	C-CAP,U 0.01-25 K B GRM	a
TUNER	O C	0937	87-012-286-080	C-CAP,U 0.01-25 K B GRM	a
TUNER	O C	0938	87-012-286-080	C-CAP,U 0.01-25 K B GRM	a
TUNER	O C	0939	87-012-286-080	C-CAP,U 0.01-25 K B GRM	a
TUNER	O C	0942	87-012-168-080	C-CAP,U 6P-50 D CH GRM	a
TUNER	O C	0946	87-012-286-080	C-CAP,U 0.01-25 K B GRM	a
TUNER	O C	0947	87-012-286-080	C-CAP,U 0.01-25 K B GRM	a

! = Δ SAFETY PARTS
 C = Components marked

All components used on this model at the production line are shown in this service manual.
 However, please note that not all components will be available as spare parts for after-sales service.
 Components marked S and O are designated as spare parts for service and will be stocked at the spare parts centers.
 Components marked X and R are not designated as spare parts for after sales service, and will not be stocked at the spare parts centers.

UNIT-NAME	! C	REF-NO	PARTS-NO	PARTS-NAME	SUFFIX&MODEL
					CZA-3 EZC
TUNER	O C	0948	87-012-270-080	C-CAP,U 470P-50 K B GRM	a
TUNER	O C	0950	86-ZA1-616-080	C-CAP,U 0.01-50 K B (MUR)	a
TUNER	O C	0952	87-012-286-080	C-CAP,U 0.01-25 K B GRM	a
TUNER	O C	0957	87-012-174-080	C-CAP,U 12P-50 J CH GRM	a
TUNER	O C	0958	87-012-286-080	C-CAP,U 0.01-25 K B GRM	a
TUNER	O C	0962	87-A10-262-080	C-CAP,U 1-10 Z F	a
TUNER	O C	0963	87-010-831-080	C-CAP,U 0.1-16 Z F	a
TUNER	O C	0971	87-010-381-010	CAP,E 330-16 M SME	a
TUNER	O C	0972	87-A11-063-080	C-CAP,S 4.7-10 Z F	a
TUNER	O C	0973	87-012-286-080	C-CAP,U 0.01-25 K B GRM	a
TUNER	O C	0974	87-012-286-080	C-CAP,U 0.01-25 K B GRM	a
TUNER	O C	0976	87-010-831-080	C-CAP,U 0.1-16 Z F	a
TUNER	O C	0979	87-012-195-080	C-CAP,U 100P-50 J CH GRM	a
TUNER	O C	0981	87-A12-066-040	CAP,E 47-16 SMG	a
TUNER	O C	0982	87-010-831-080	C-CAP,U 0.1-16 Z F	a
TUNER	O C	0983	87-012-286-080	C-CAP,U 0.01-25 K B GRM	a
TUNER	O C	0984	87-012-286-080	C-CAP,U 0.01-25 K B GRM	a
TUNER	O C	0985	87-012-195-080	C-CAP,U 100P-50 J CH GRM	a
TUNER	O C	0987	87-012-286-080	C-CAP,U 0.01-25 K B GRM	a
TUNER	O C	0988	87-012-286-080	C-CAP,U 0.01-25 K B GRM	a
					CZA-3 EZC
TUNER	O C	0989	87-012-286-080	C-CAP,U 0.01-25 K B GRM	a
TUNER	O C	0990	87-012-195-080	C-CAP,U 100P-50 J CH GRM	a
TUNER	O C	0991	87-012-182-080	C-CAP,U 27P-50 J CH GRM	a
TUNER	O C	0992	87-012-172-080	C-CAP,U 10P-50 D CH GRM	a
TUNER	O C	0993	87-012-274-080	C-CAP,U 1000P-50 K B GRM	a
TUNER	O C	0994	87-012-195-080	C-CAP,U 100P-50 J CH GRM	a
TUNER	O C	0995	87-012-274-080	C-CAP,U 1000P-50 K B GRM	a
TUNER	O C	0996	87-012-195-080	C-CAP,U 100P-50 J CH GRM	a
TUNER	O C	0997	87-010-831-080	C-CAP,U 0.1-16 Z F	a
TUNER	O C	0998	87-A12-066-040	CAP,E 47-16 SMG	a
TUNER	O C	0999	87-012-286-080	C-CAP,U 0.01-25 K B GRM	a
TUNER	O CF	0831	87-008-423-010	FLTR,CF SFE10.7MS3G-A	a
TUNER	O CF	0832	82-785-747-010	CF,MS2GH-A	a
TUNER	O CN	0991	87-A60-650-010	CONN,16P H GRY TUC-R16X-C1	a
TUNER	S D	0801	87-020-465-080	DIODE,1SS133	a
TUNER	S D	0803	87-020-465-080	DIODE,1SS133	a
TUNER	O D	0901	87-A41-048-040	C-VARI-CAP,HVM16-03 TL	a
TUNER	O D	0902	87-A41-048-040	C-VARI-CAP,HVM16-03 TL	a
TUNER	O D	0903	87-A41-048-040	C-VARI-CAP,HVM16-03 TL	a
TUNER	S D	0942	87-A40-270-080	C-DIODE,MC2838	a
					CZA-3 EZC
TUNER	O D	0951	87-A40-799-040	C-VARI-CAP,KV1610S	a
TUNER	S D	0991	87-017-149-080	ZENER,HZS6A2L	a
TUNER	S D	0992	87-020-465-080	DIODE,1SS133	a
TUNER	S IC	0801	87-A22-060-010	IC,LA1845N-A	a
TUNER	S IC	0991	87-A21-928-010	IC,LC72131D-N	a
TUNER	O J	0832	87-A61-823-010	TERMINAL,ANT PAL AJ-2073	a
TUNER	O J	0940	87-A60-633-010	CONN,2P H 2.5MM JMT	a
TUNER	O JR	0783	88-108-103-080	C-RES,U 10K-1/16W J	a
TUNER	S JW	0942	87-020-465-080	DIODE,1SS133	a
TUNER	O JW	0959	87-A11-132-080	CAP,TC U 0.01-50 K B	a
TUNER	O L	0801	87-A50-694-010	COIL,FM-DET 2 (COILS)	a
TUNER	O L	0802	87-A91-551-010	FLTR,PCFJZH-450 L (TOK)	a
TUNER	O L	0811	87-005-847-080	COIL,2.2UH K CECS	a
TUNER	O L	0832	87-005-847-080	COIL,2.2UH K CECS	a
TUNER	O L	0901	86-ZA1-612-010	COIL,FM ANT/RF-1-Z	a
TUNER	O L	0902	86-ZA1-613-010	COIL,FM ANT/RF-2-Z	a
TUNER	O L	0903	87-003-098-080	COIL,2.2UH K LAL02	a
TUNER	O L	0904	86-ZA1-612-010	COIL,FM ANT/RF-1-Z	a
TUNER	O L	0905	86-ZA1-613-010	COIL,FM ANT/RF-2-Z	a
TUNER	O L	0906	87-005-847-080	COIL,2.2UH K CECS	a
					CZA-3 EZC
TUNER	O L	0907	86-ZA1-614-010	COIL,FM OSC-Z	a
TUNER	O L	0908	88-ZA1-624-010	COIL,FM IFT 7-6.2 (COILS)	a
TUNER	O L	0941	87-A50-020-010	COIL,ANT LW (COI) 252KHZ	a
TUNER	O L	0942	87-A50-019-010	COIL,OSC LW (COI) 856KHZ	a
TUNER	O L	0952	87-A50-754-010	COIL,MW ANT (3BLW)	a
TUNER	O L	0953	87-A50-755-010	COIL,MW OSC (3BLW)	a
TUNER	S Q	0835	89-327-143-080	C-TR,2SC27140	a
TUNER	S Q	0836	87-A30-677-040	C-TR,SRA2207S	a
TUNER	S Q	0901	89-503-602-080	C-FET,2SK360E	a
TUNER	S Q	0902	87-A30-664-080	C-TR,2SC2620B	a
TUNER	S Q	0903	87-A30-664-080	C-TR,2SC2620B	a
TUNER	S Q	0904	87-A30-699-040	C-TR,2SC5477-T22	a
TUNER	S Q	0905	87-A30-664-080	C-TR,2SC2620B	a
TUNER	S Q	0948	87-A30-675-040	C-TR,2SD1306NE07TL	a
TUNER	S Q	0951	87-A30-074-080	C-TR,RT1P 141C	a
TUNER	S Q	0952	87-A30-675-040	C-TR,2SD1306NE07TL	a
TUNER	S Q	0953	89-503-602-080	C-FET,2SK360E	a
TUNER	S Q	0981	87-A30-494-080	TR,2SA1980G	a
TUNER	S Q	0982	87-A30-540-040	C-TR,2SC5343SF/S (G)	a
TUNER	S Q	0983	87-A30-540-040	C-TR,2SC5343SF/S (G)	a

! = Δ SAFETY PARTS
 C = Components marked

All components used on this model at the production line are shown in this service manual.
 However, please note that not all components will be available as spare parts for after-sales service.
 Components marked S and O are designated as spare parts for service and will be stocked at the spare parts centers.
 Components marked X and R are not designated as spare parts for after sales service, and will not be stocked at the spare parts centers.

UNIT-NAME	! C	REF-NO	PARTS-NO	PARTS-NAME	SUFFIX&MODEL
					CZA-3 EZC
TUNER	X R	0789	88-108-333-080	C-RES,U 33K-1/16W J	a
TUNER	O R	0790	87-012-286-080	C-CAP,U 0.01-25 K B GRM	a
TUNER	O R	0791	88-108-102-080	C-RES,U 1K-1/16W J	a
TUNER	X R	0793	88-108-221-080	C-RES,U 220-1/16W J	a
TUNER	O R	0801	88-108-103-080	C-RES,U 10K-1/16W J	a
TUNER	O R	0802	88-108-223-080	C-RES,U 22K-1/16W J	a
TUNER	X R	0803	88-108-183-080	C-RES,U 18K-1/16W J	a
TUNER	O R	0805	88-108-332-080	C-RES,U 3.3K-1/16W J	a
TUNER	X R	0806	88-108-682-080	C-RES,U 6.8K-1/16W J	a
TUNER	O R	0813	88-108-224-080	C-RES,U 220K-1/16W J	a
TUNER	X R	0814	88-108-222-080	C-RES,U 2.2K-1/16W J	a
TUNER	X R	0815	88-121-682-080	RES,6.8K-1/8W J	a
TUNER	X R	0816	88-108-472-080	C-RES,U 4.7K-1/16W J	a
TUNER	O R	0818	88-108-103-080	C-RES,U 10K-1/16W J	a
TUNER	X R	0823	88-108-393-080	C-RES,U 39K-1/16W J	a
TUNER	O R	0826	88-108-223-080	C-RES,U 22K-1/16W J	a
TUNER	X R	0832	88-108-391-080	C-RES,U 390-1/16W J	a
TUNER	X R	0840	88-108-221-080	C-RES,U 220-1/16W J	a
TUNER	O R	0850	88-108-103-080	C-RES,U 10K-1/16W J	a
TUNER	O R	0853	88-108-102-080	C-RES,U 1K-1/16W J	a
					CZA-3 EZC
TUNER	X R	0854	88-108-331-080	C-RES,U 330-1/16W J	a
TUNER	X R	0855	88-108-183-080	C-RES,U 18K-1/16W J	a
TUNER	O R	0856	88-108-103-080	C-RES,U 10K-1/16W J	a
TUNER	X R	0857	88-108-181-080	C-RES,U 180-1/16W J	a
TUNER	X R	0858	88-108-271-080	C-RES,U 270-1/16W J	a
TUNER	X R	0860	88-121-101-080	RES,100-1/8W J	a
TUNER	X R	0890	88-108-474-080	C-RES,U 470K-1/16W J	a
TUNER	X R	0901	88-108-104-080	C-RES,U 100K-1/16W J	a
TUNER	X R	0902	88-108-104-080	C-RES,U 100K-1/16W J	a
TUNER	X R	0903	88-108-221-080	C-RES,U 220-1/16W J	a
TUNER	O R	0904	88-108-103-080	C-RES,U 10K-1/16W J	a
TUNER	X R	0905	88-108-221-080	C-RES,U 220-1/16W J	a
TUNER	X R	0906	88-108-564-080	C-RES,U 560K-1/16W J	a
TUNER	X R	0908	88-108-271-080	C-RES,U 270-1/16W J	a
TUNER	X R	0909	88-108-181-080	C-RES,U 180-1/16W J	a
TUNER	X R	0910	88-108-334-080	C-RES,U 330K-1/16W J	a
TUNER	X R	0911	88-108-181-080	C-RES,U 180-1/16W J	a
TUNER	X R	0912	88-108-104-080	C-RES,U 100K-1/16W J	a
TUNER	X R	0913	88-108-152-080	C-RES,U 1.5K-1/16W J	a
TUNER	X R	0914	88-108-472-080	C-RES,U 4.7K-1/16W J	a
					CZA-3 EZC
TUNER	X R	0915	88-108-104-080	C-RES,U 100K-1/16W J	a
TUNER	X R	0916	88-108-470-080	C-RES,U 47-1/16W J	a
TUNER	O R	0944	88-108-101-080	C-RES,U 100-1/16W J	a
TUNER	X R	0945	88-108-104-080	C-RES,U 100K-1/16W J	a
TUNER	X R	0947	88-108-183-080	C-RES,U 18K-1/16W J	a
TUNER	X R	0948	88-108-472-080	C-RES,U 4.7K-1/16W J	a
TUNER	O R	0952	88-108-562-080	C-RES,U 5.6K-1/16W J	a
TUNER	X R	0954	88-108-222-080	C-RES,U 2.2K-1/16W J	a
TUNER	X R	0956	88-108-471-080	C-RES,U 470-1/16W J	a
TUNER	X R	0958	88-108-472-080	C-RES,U 4.7K-1/16W J	a
TUNER	O R	0959	88-108-103-080	C-RES,U 10K-1/16W J	a
TUNER	X R	0962	88-121-221-080	RES,220-1/8W J	a
TUNER	X R	0964	88-108-330-080	C-RES,U 33-1/16W J	a
TUNER	O R	0972	88-108-102-080	C-RES,U 1K-1/16W J	a
TUNER	O R	0973	88-108-102-080	C-RES,U 1K-1/16W J	a
TUNER	O R	0974	88-108-101-080	C-RES,U 100-1/16W J	a
TUNER	O R	0975	88-108-562-080	C-RES,U 5.6K-1/16W J	a
TUNER	O R	0976	88-108-102-080	C-RES,U 1K-1/16W J	a
TUNER	O R	0977	88-108-102-080	C-RES,U 1K-1/16W J	a
TUNER	X R	0978	88-108-681-080	C-RES,U 680-1/16W J	a
					CZA-3 EZC
TUNER	X R	0980	88-108-684-080	C-RES,U 680K-1/16W J	a
TUNER	X R	0981	88-121-471-080	RES,470-1/8W J	a
TUNER	O R	0982	88-108-103-080	C-RES,U 10K-1/16W J	a
TUNER	O R	0983	88-108-562-080	C-RES,U 5.6K-1/16W J	a
TUNER	O R	0984	88-108-562-080	C-RES,U 5.6K-1/16W J	a
TUNER	X R	0985	88-121-471-080	RES,470-1/8W J	a
TUNER	X R	0986	88-108-222-080	C-RES,U 2.2K-1/16W J	a
TUNER	X R	0989	88-121-102-080	RES,1K-1/8W J	a
TUNER	O R	0990	88-108-563-080	C-RES,U 56K-1/16W J	a
TUNER	O R	0992	88-108-103-080	C-RES,U 10K-1/16W J	a
TUNER	O R	0994	88-108-103-080	C-RES,U 10K-1/16W J	a
TUNER	O R	0996	88-108-103-080	C-RES,U 10K-1/16W J	a
TUNER	X R	0997	88-108-154-080	C-RES,U 150K-1/16W J	a
TUNER	O R	0998	88-108-102-080	C-RES,U 1K-1/16W J	a
TUNER	O R	0999	88-108-103-080	C-RES,U 10K-1/16W J	a
TUNER	X SH	0901	8C-ZA3-604-010	SHLD-CASE,CZA-3	a
TUNER	X SH	0902	8C-ZA3-619-010	SHLD-CASE,CZA-3 EZ P	a
TUNER	X SH	0903	8C-ZA3-618-010	SHLD-CASE,CZA-3 EZ S	a
TUNER	O TC	0942	87-A91-774-080	TRIMMER,PLY 30P 6.8X5.4 CDYL	a
TUNER	O X	0992	87-A70-306-010	VIB,XTAL 4.500MHZ CSA-309ST	a

ELECTRICAL PARTS LIST (3ZG - 3)

! =  SAFTY PARTS
 C = Components marked

All components used on this model at the production line are shown in this service manual.
 However, please note that not all components will be available as spare parts for after-sales service.
 Components marked S and O are designated as spare parts for service and will be stocked at the spare parts centers.
 Components marked X and R are not designated as spare parts for after sales service, and will not be stocked at the spare parts centers.

UNIT-NAME	! C	REF-NO	PARTS-NO	PARTS-NAME	SUFFIX&MODEL
					3ZG-3
					E2NC
LOAD	O	CON402	87-099-210-010	CONN, 5P H BLK 6216	a
LOAD	O	M 001	87-045-305-010	MOT, RF-500TB	a
LOAD	O	SW 001	87-036-110-010	SW, MICRO SPPB62	a
LOAD	O	SW 002	87-036-110-010	SW, MICRO SPPB62	a

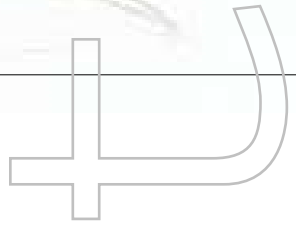
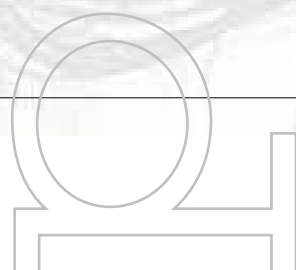
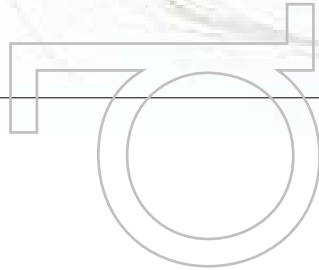
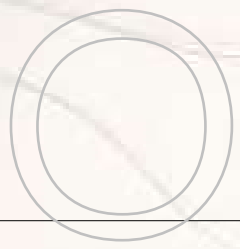
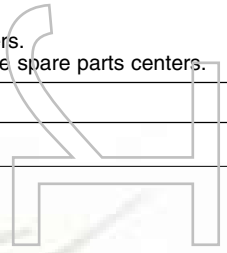

ELECTRICAL PARTS LIST (3ZG - 2)

- ! =  SAFTY PARTS
- C = Components marked

All components used on this model at the production line are shown in this service manual.
 However, please note that not all components will be available as spare parts for after-sales service.
 Components marked S and O are designated as spare parts for service and will be stocked at the spare parts centers.
 Components marked X and R are not designated as spare parts for after sales service, and will not be stocked at the spare parts centers.

UNIT-NAME	! C	REF-NO	PARTS-NO	PARTS-NAME	SUFFIX&MODEL
					3ZG-2
					E3NC
DRIVE	O	CON201	87-A60-086-010	CONN,06P H 6216	a
DRIVE	O	M 020	87-045-356-010	MOT,RF-310TA 30	a
DRIVE	O	M 021	87-045-358-010	MOT,RF-310TA 43	a
DRIVE	O	SW 001	87-A90-042-010	SW,LEAF MSW-17310MVPO	a

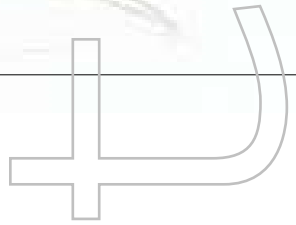
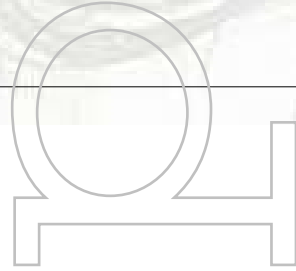
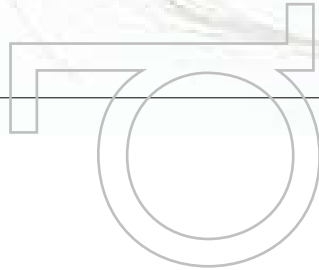
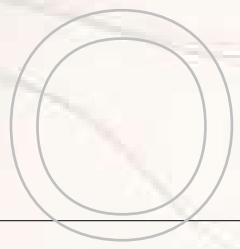
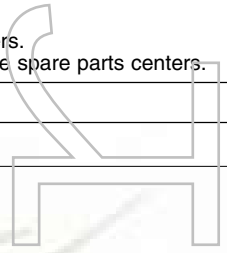

チップ抵抗部品コード／CHIP RESISTOR PART CODE

チップ抵抗部品コードの成り立ち

Chip Resistor Part Coding

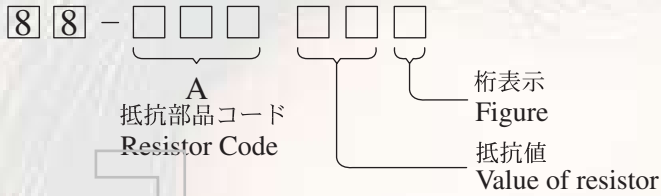

チップ抵抗
Chip resistor

容量 Wattage	種類 Type	許容誤差 Tolerance	記号 Symbol	寸法/Dimensions (mm)			抵抗コード : A Resistor Code : A	
				外形/Form	L	W		t
1/16W	1005	± 5%	CJ		1.0	0.5	0.35	104
1/16W	1608	± 5%	CJ		1.6	0.8	0.45	108
1/10W	2125	± 5%	CJ		2	1.25	0.45	118
1/8W	3216	± 5%	CJ		3.2	1.6	0.55	128

TRANSISTOR ILLUSTRATION

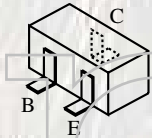

- 2SA1162GR
- 2SC2620B
- 2SC2712GR
- 2SC2714O
- 2SC3052
- 2SC5343SF/S(G)
- 2SC5477-T22
- 2SD1306NE07TL
- DTA114EK
- DTA124EUA
- RT1P141C
- SRA2207S

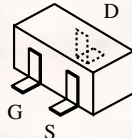

- 2SK2158
- 2SK360E



- 2SB1342
- 2SB1370(30W)
- 2SD1933



E C B

- 2SA1296GR
- 2SA1980G



E C B

- 2SA1979O/Y



E C B

- 2SC5343GL

WIRING - 1 (MAIN) <1 / 2>

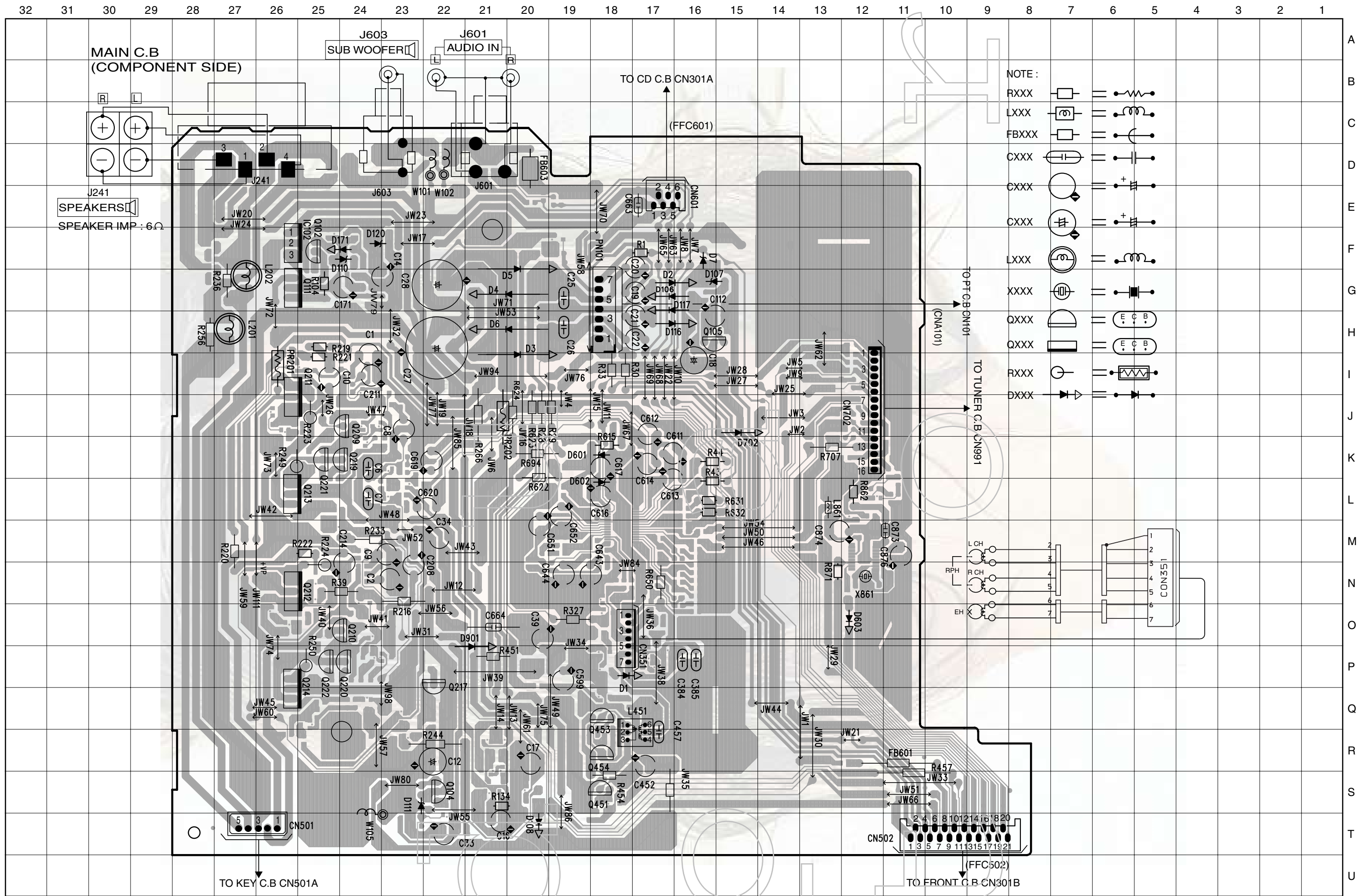

- NOTE :
- RXXX
 - LXXX
 - FBXXX
 - CXXX
 - CXXX
 - LXXX
 - XXXX
 - QXXX
 - QXXX
 - RXXX
 - DXXX

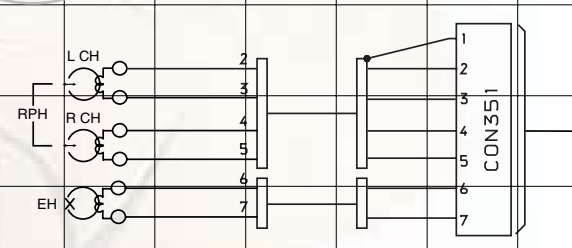

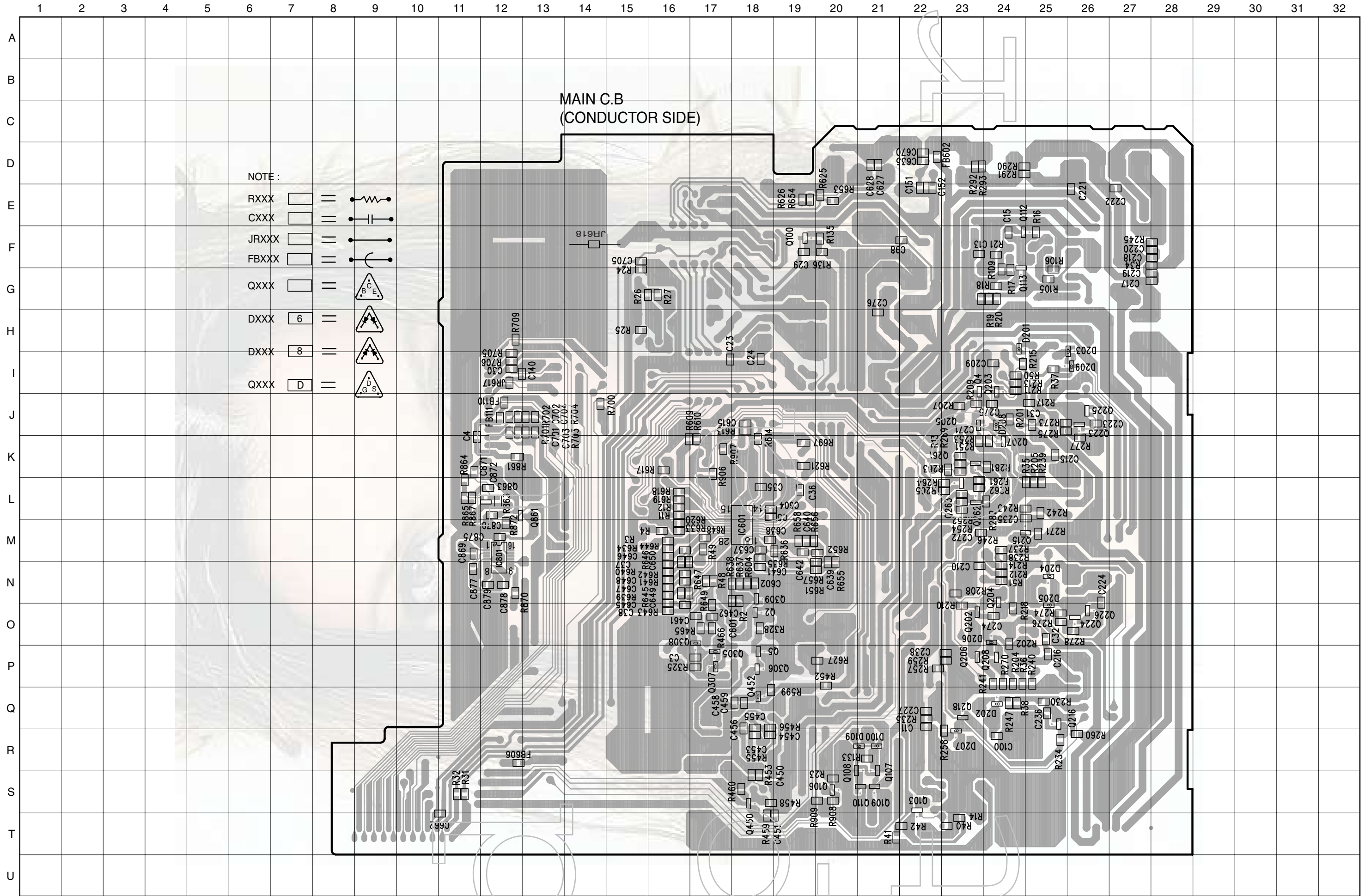





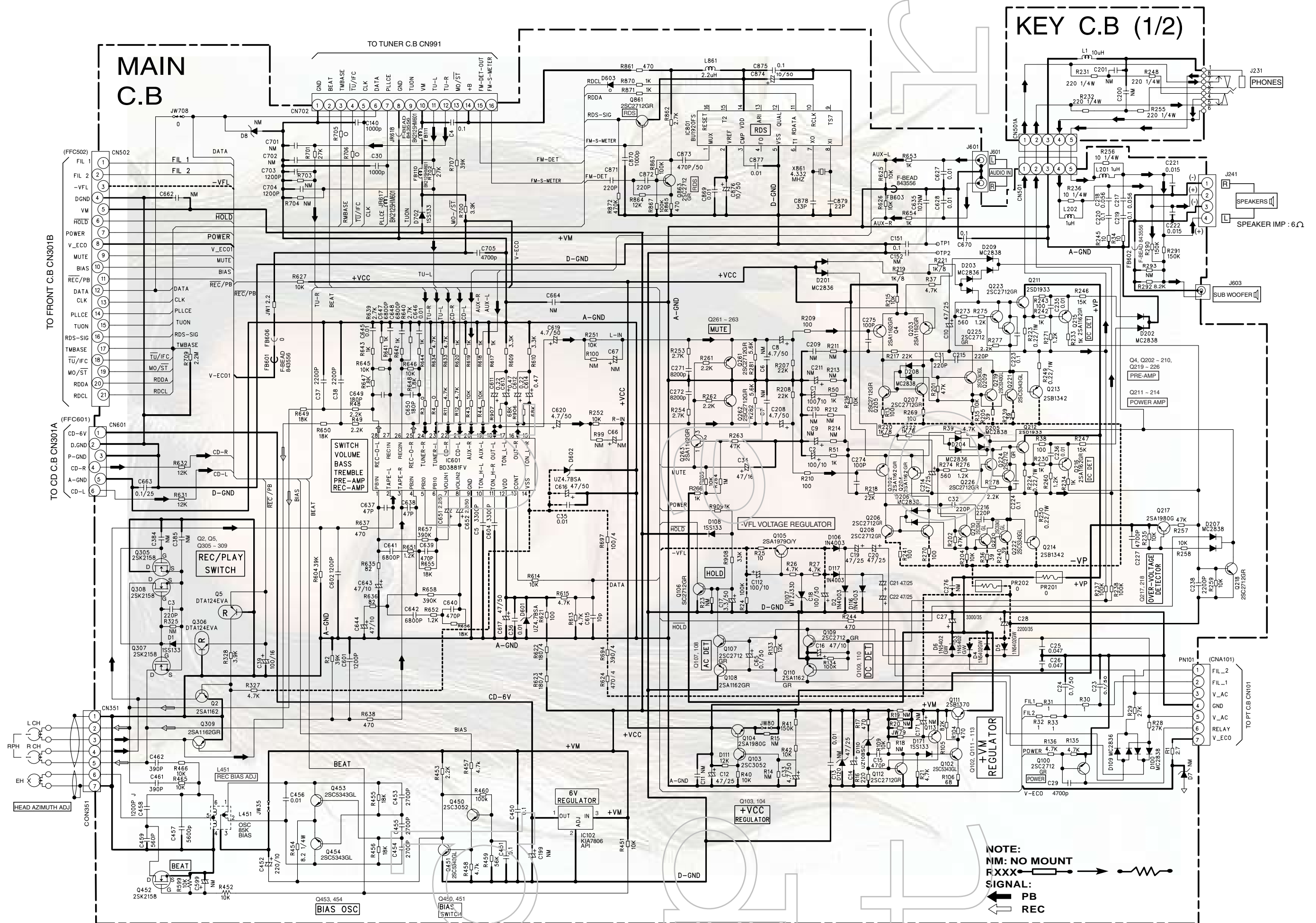

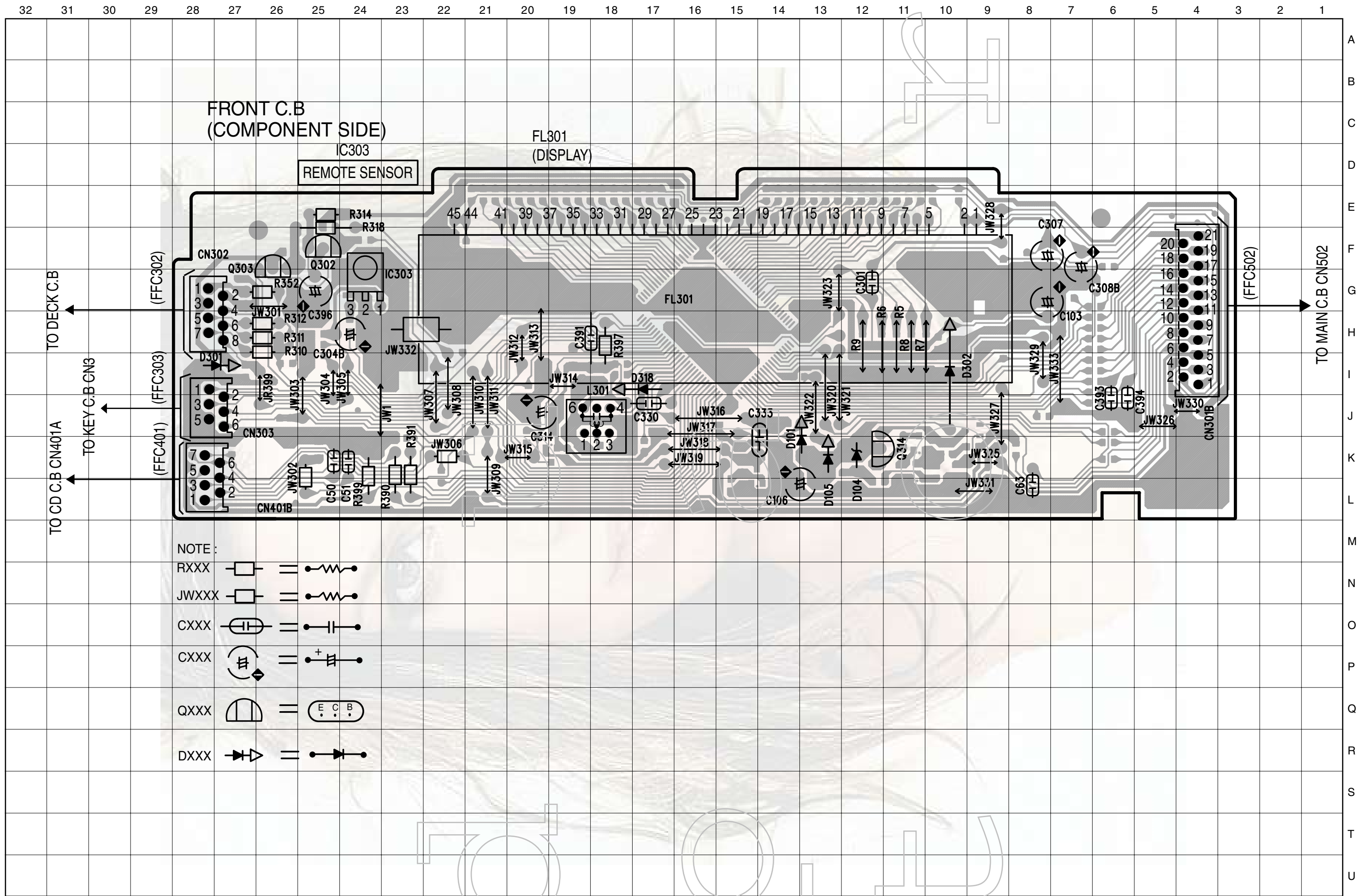











NOTE :

RXXX		==	
CXXX		==	
JRXXX		==	
FBXXX		==	
QXXX		==	
DXXX		==	
DXXX		==	
QXXX		==	







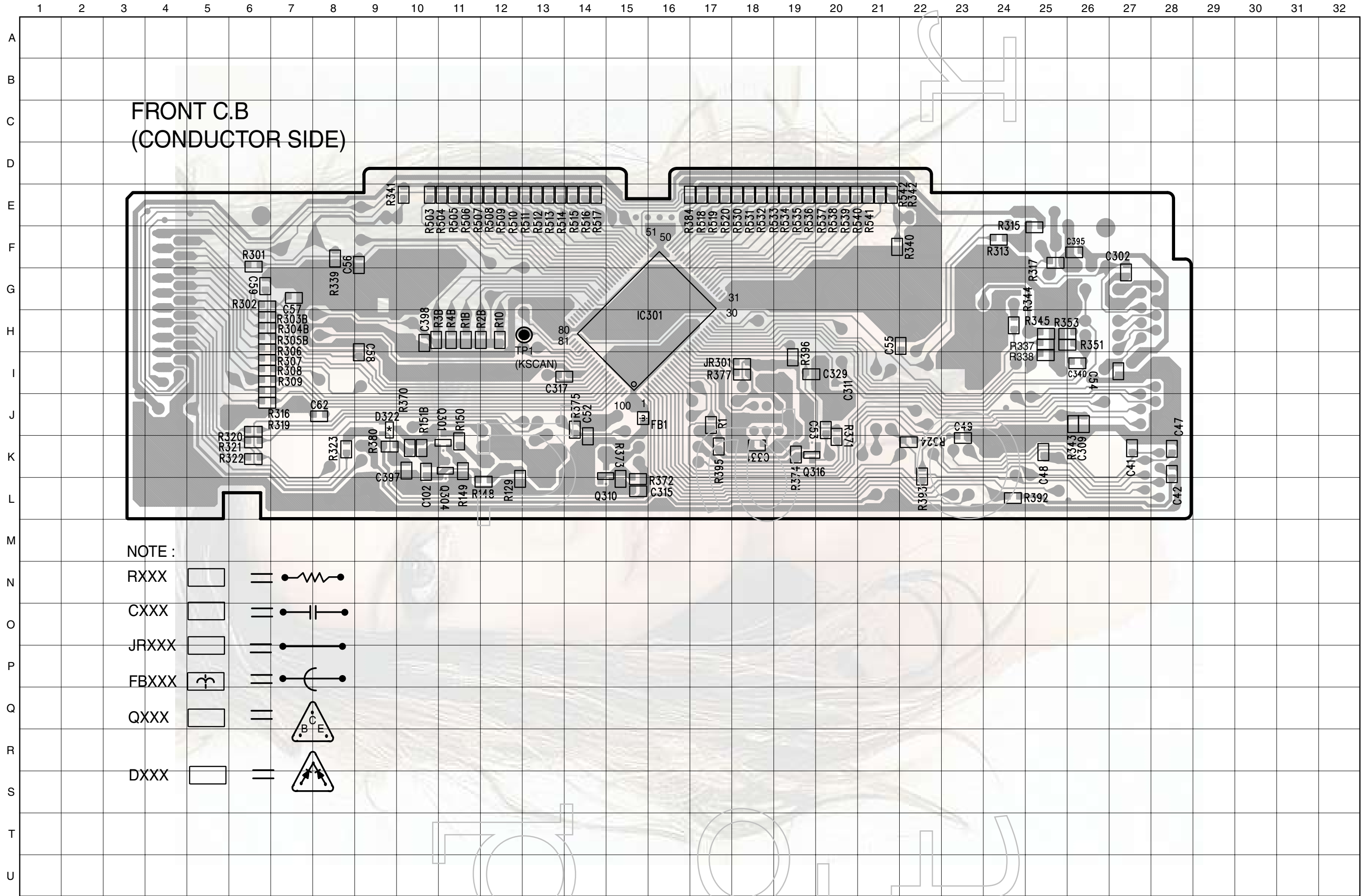







- NOTE :
- RXXX   
 - JWXXX   
 - CXXX   
 - CXXX   
 - QXXX   
 - DXXX   

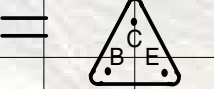

FRONT C.B
(CONDUCTOR SIDE)

NOTE :

- RXXX  
- CXXX  
- JRXXX  
- FBXXX  
- QXXX  
- DXXX  

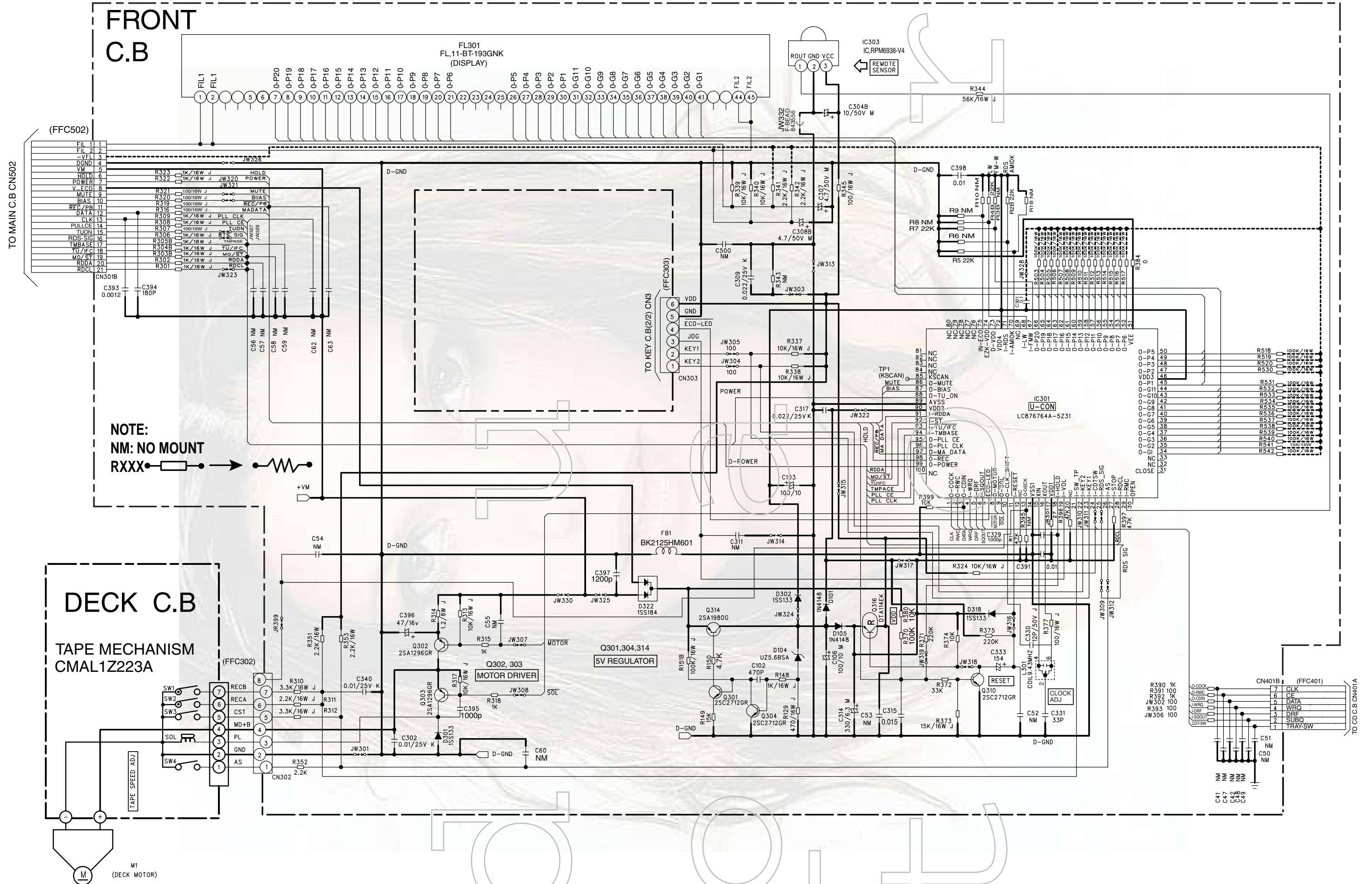

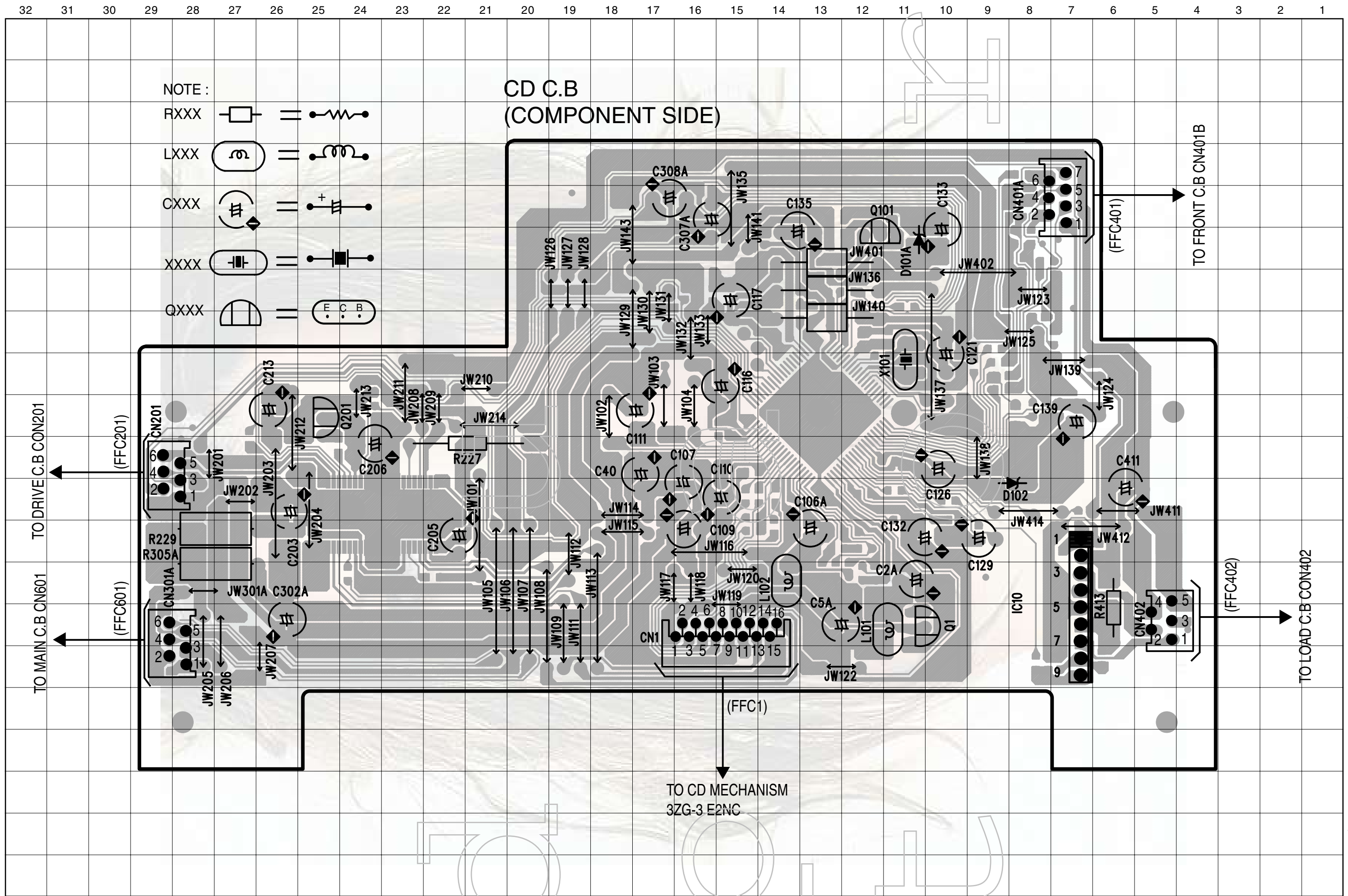

- NOTE :
- RXXX
 - LXXX
 - CXXX
 - XXXX
 - QXXX

CD C.B
(COMPONENT SIDE)

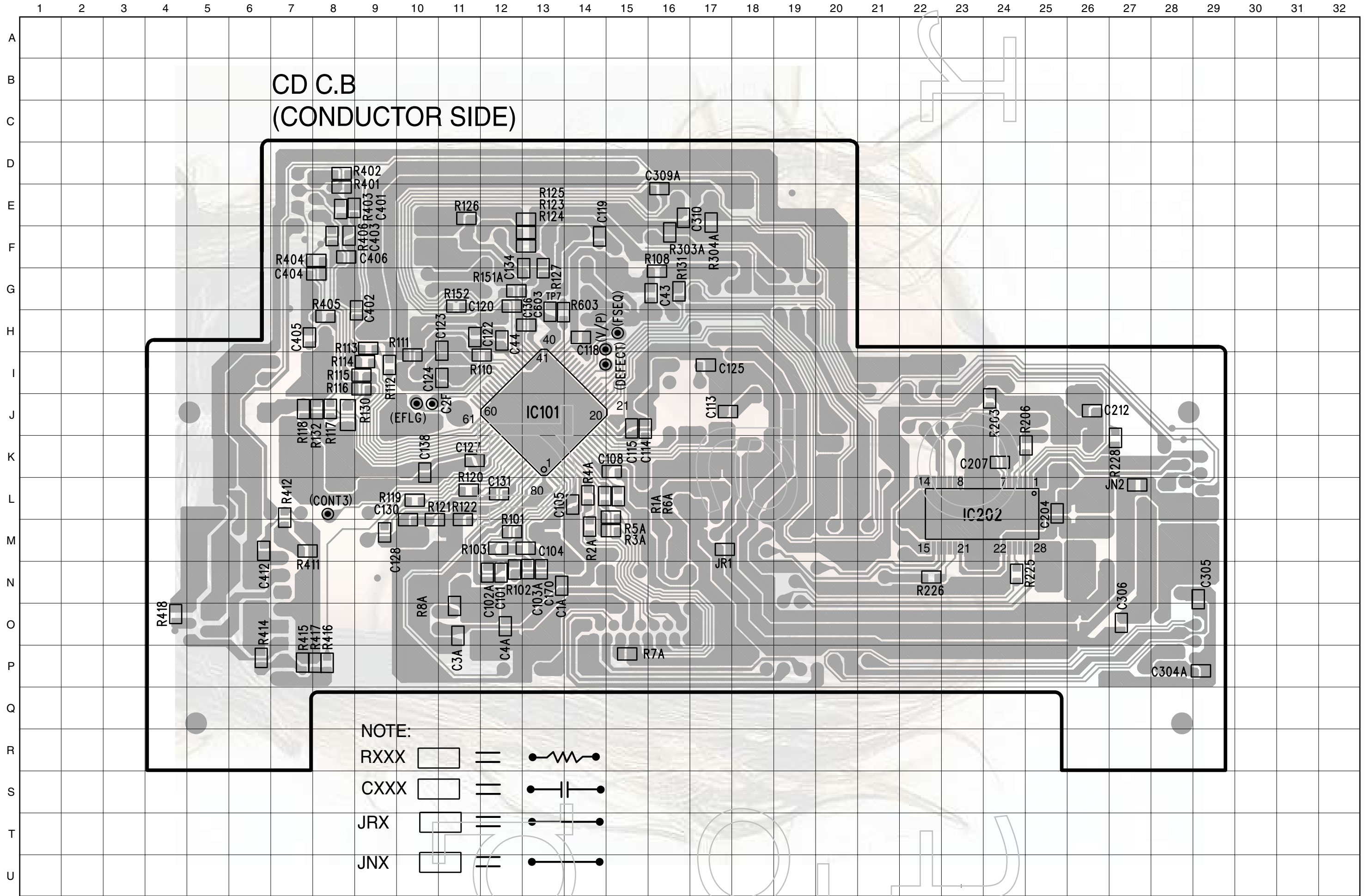

SCHEMATIC DIAGRAM - 3 (CD / DRIVE / LOAD)

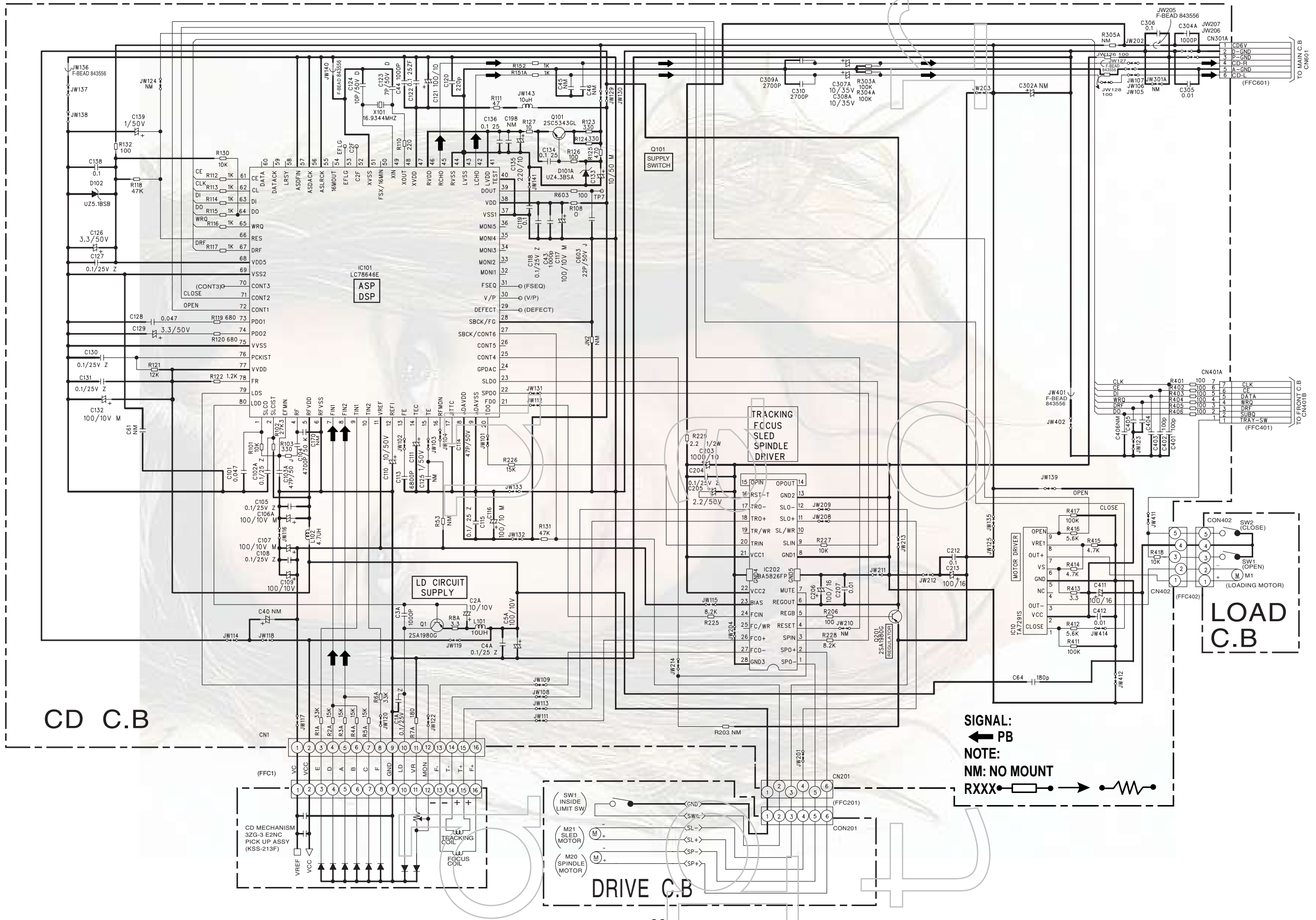

TUNER C.B

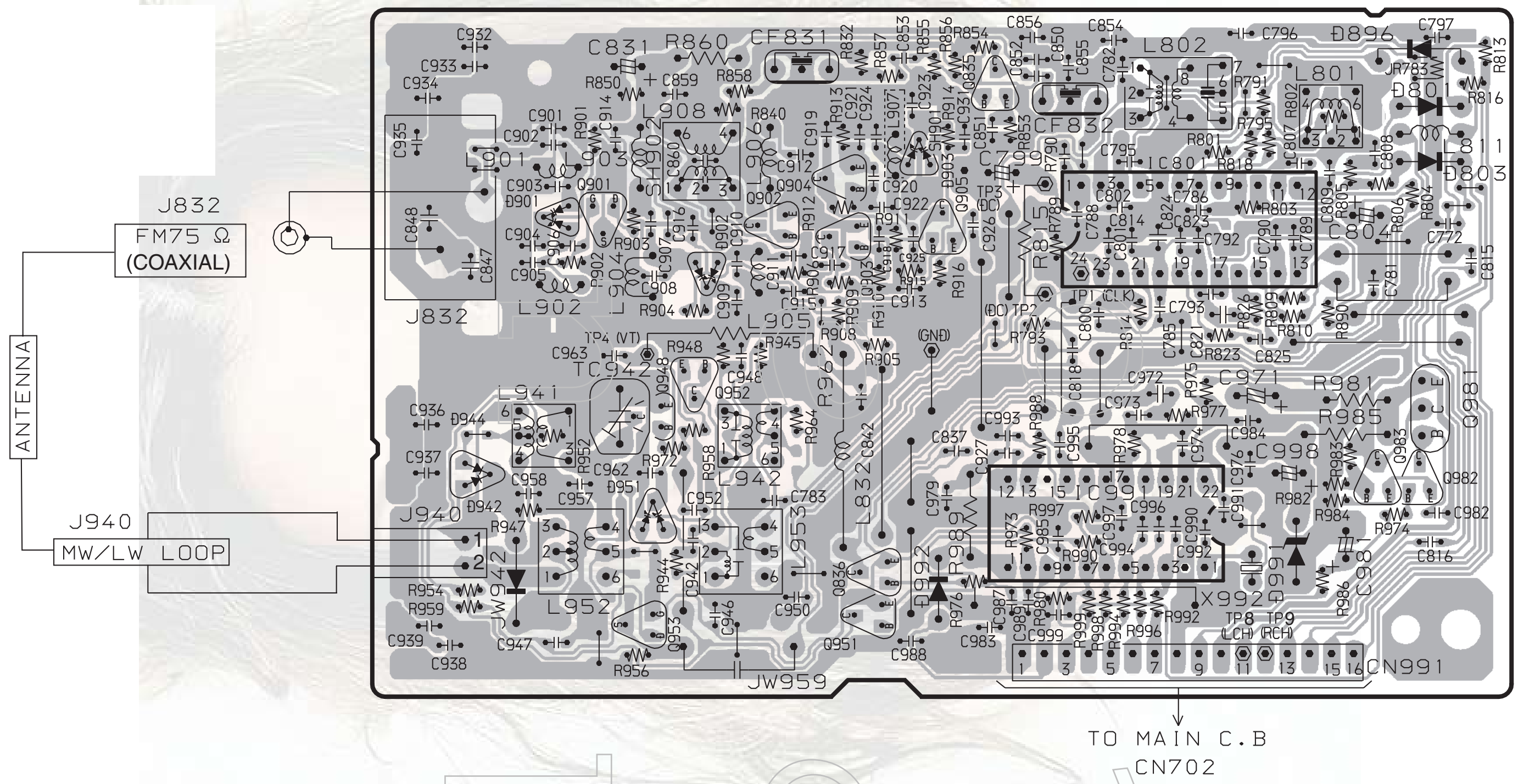

SCHEMATIC DIAGRAM – 4 (TUNER)

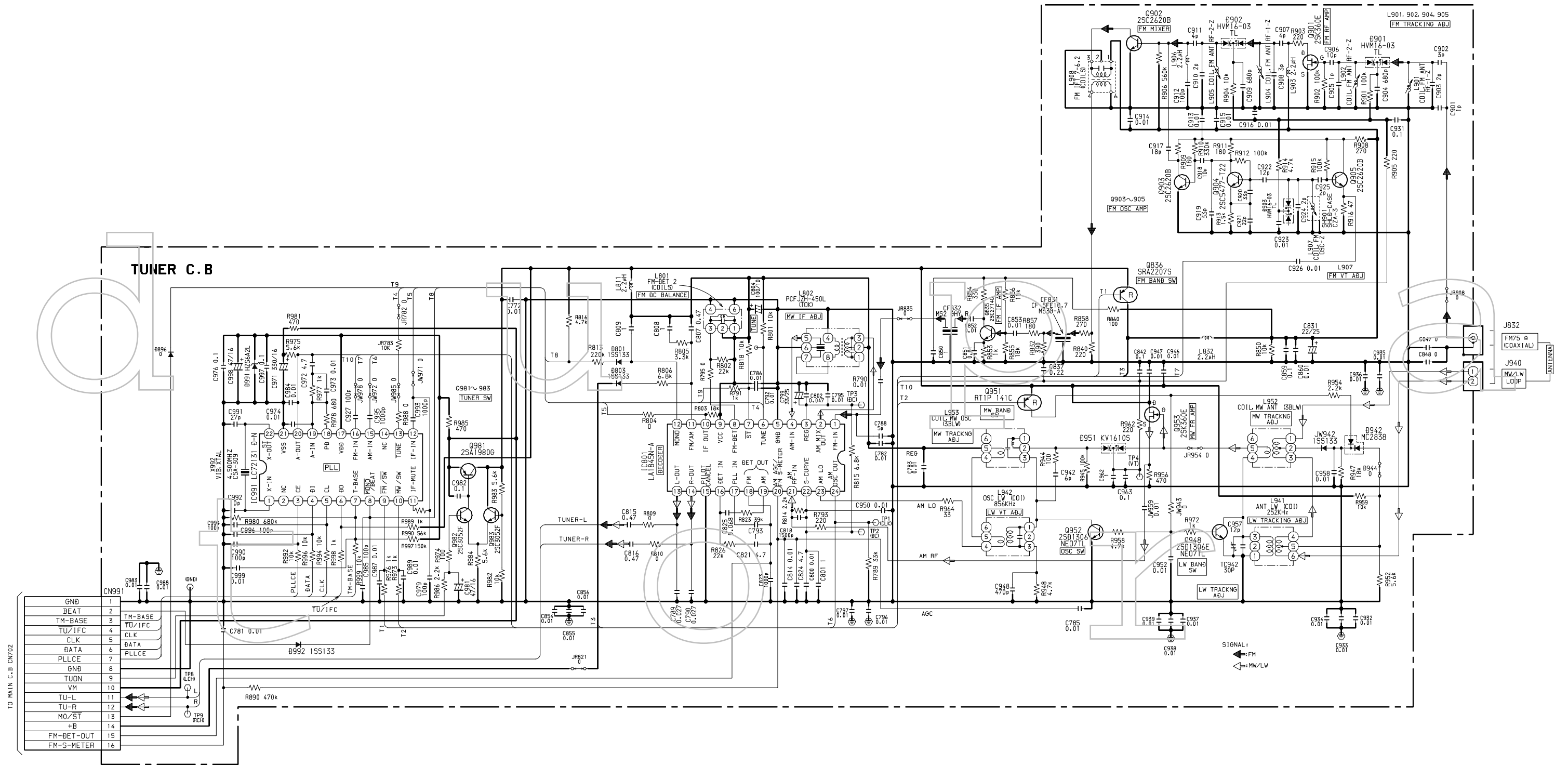

PT C.B

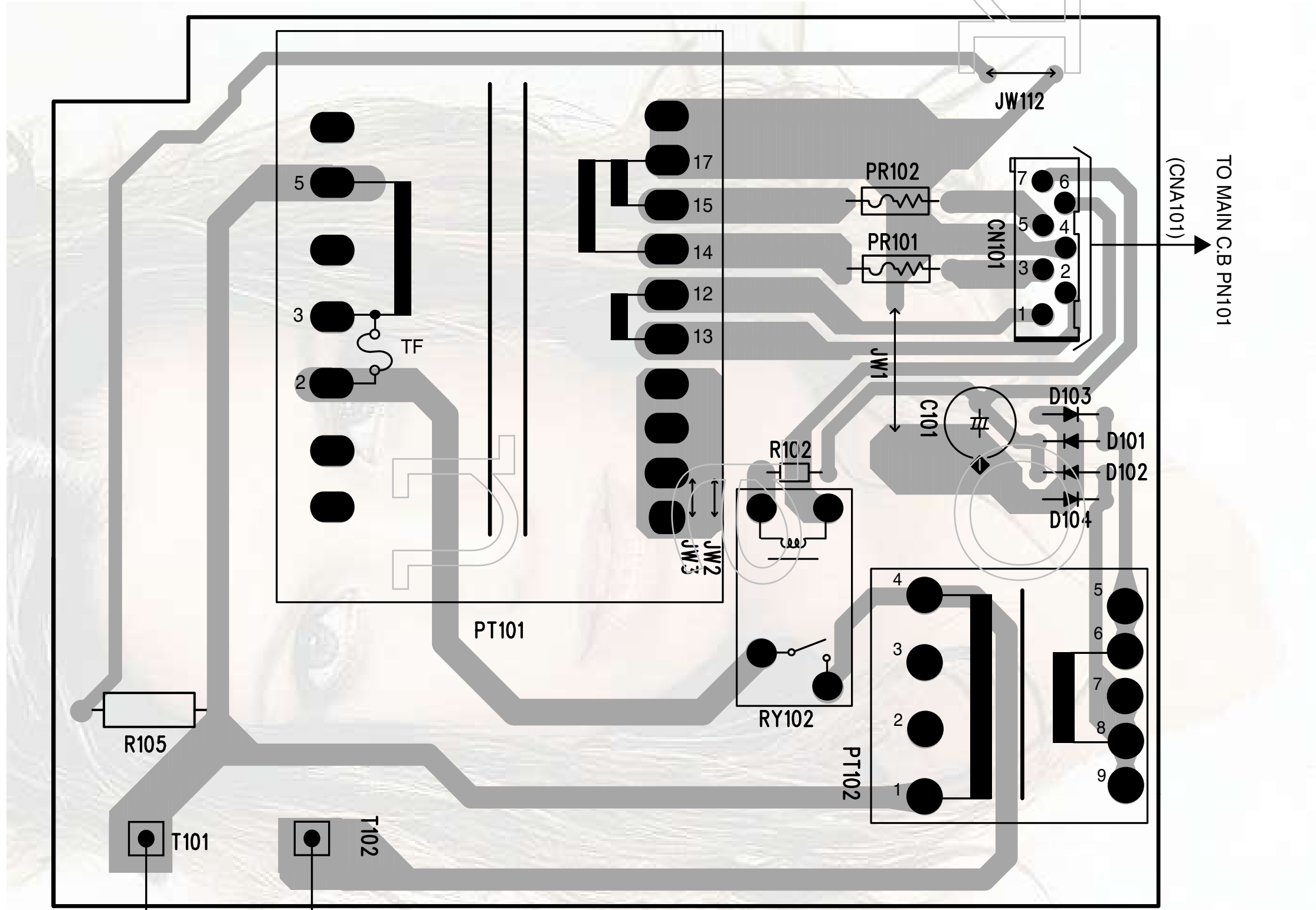

NOTE :
 RXXX = [Resistor symbol]
 CXXX = [Capacitor symbol]

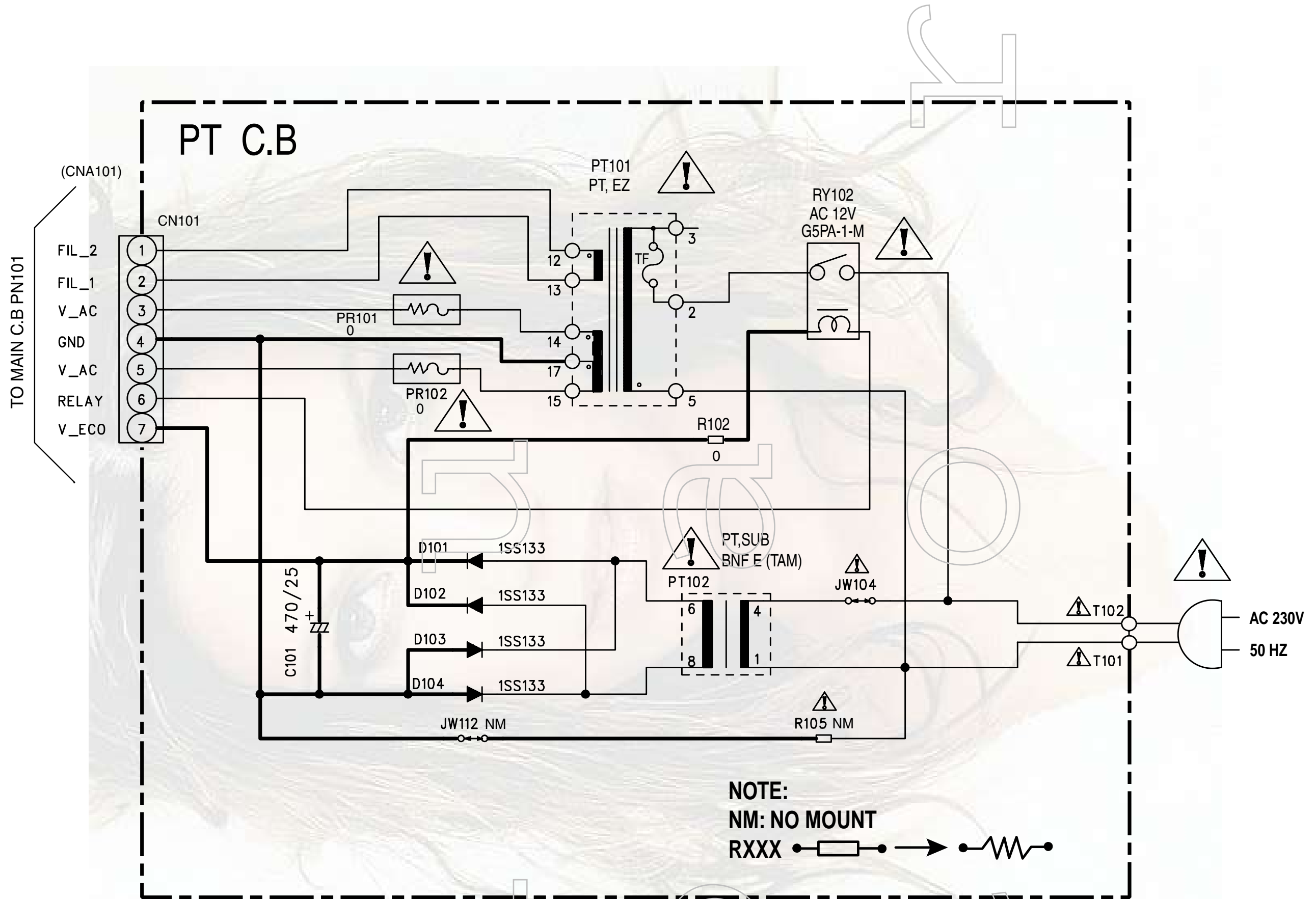

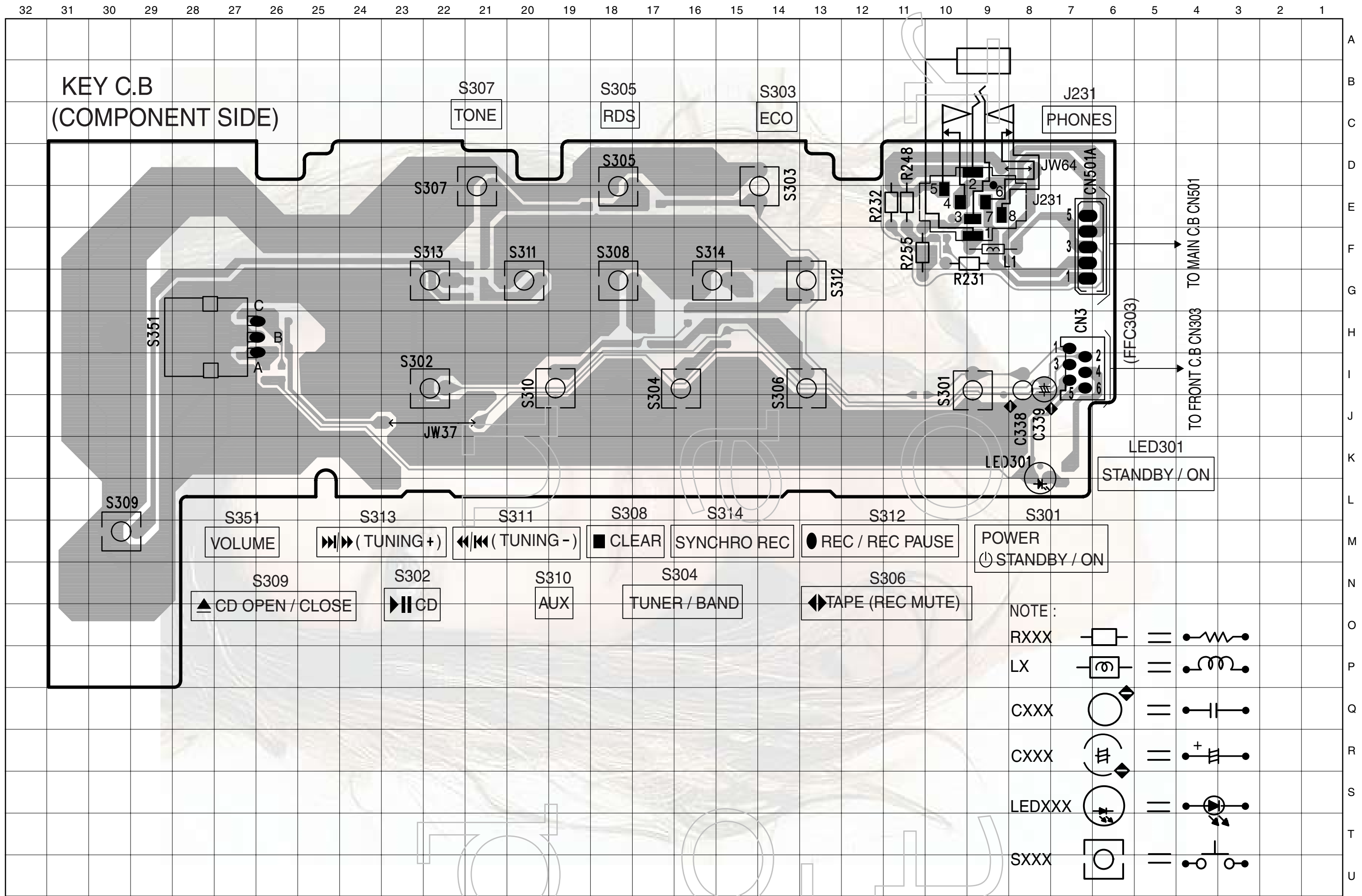

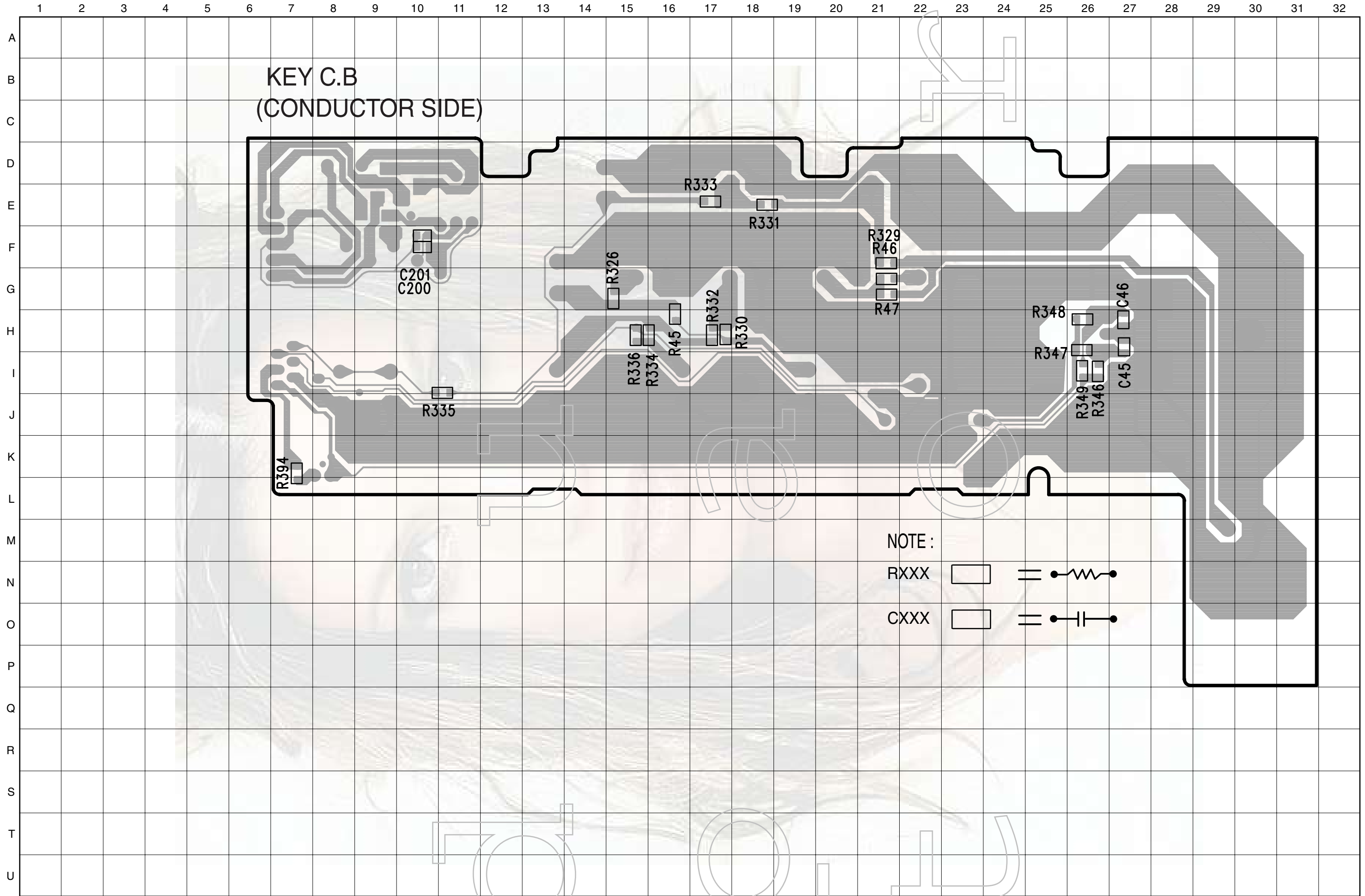

NOTE :

RXXX  = 

CXXX  = 

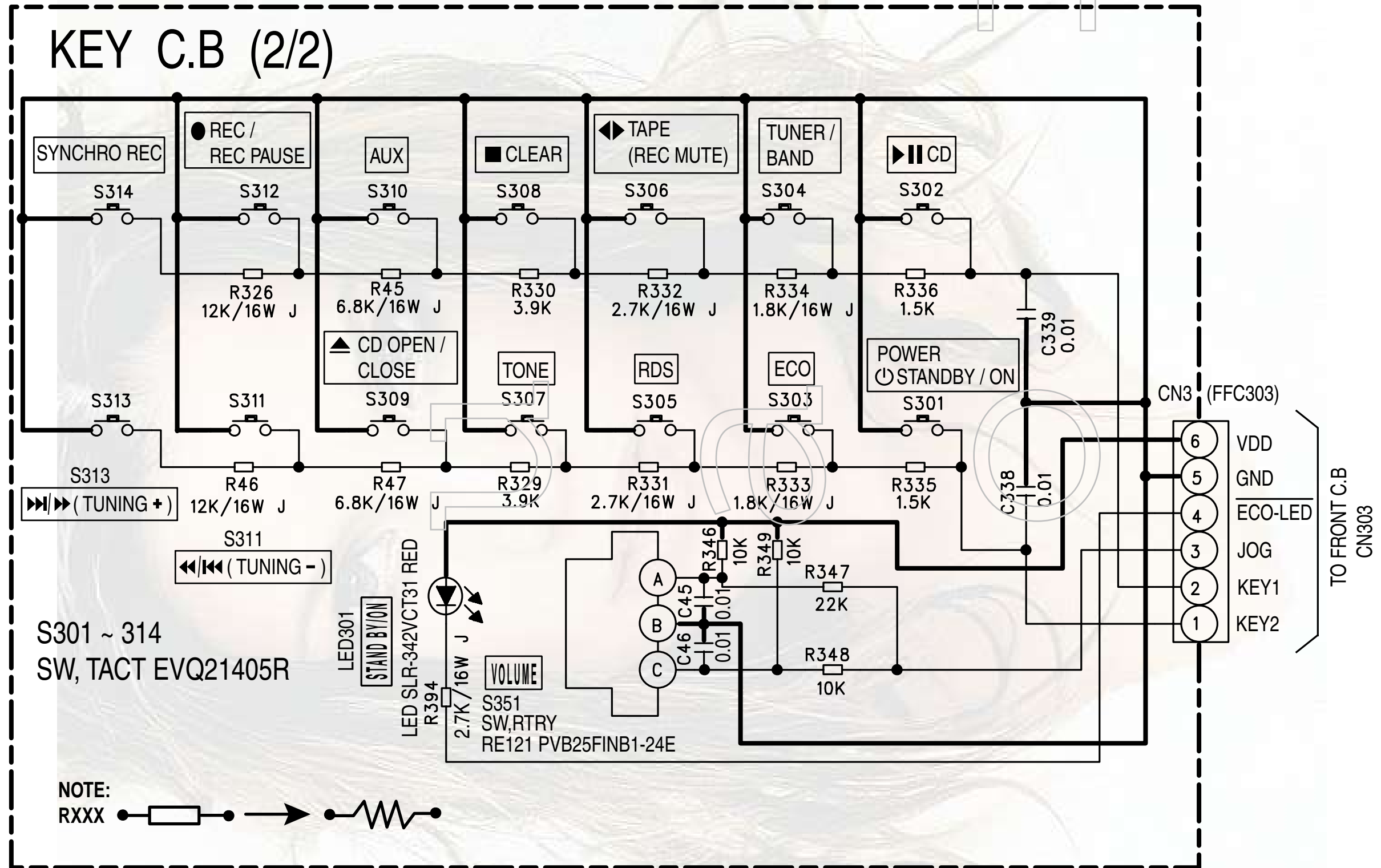

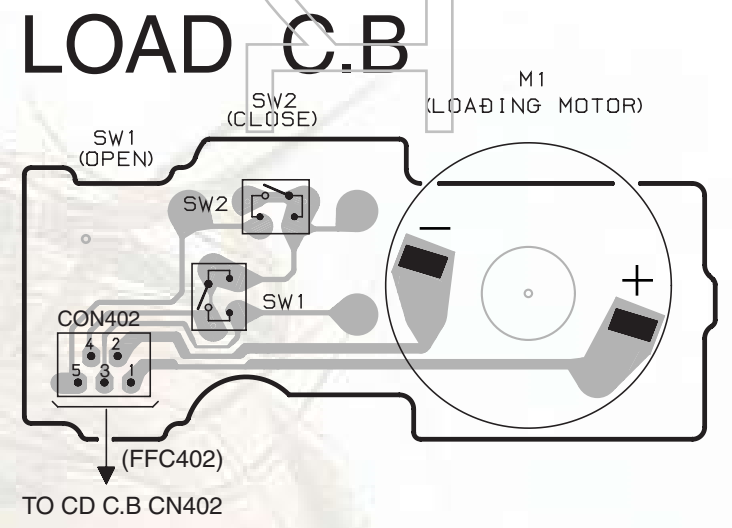
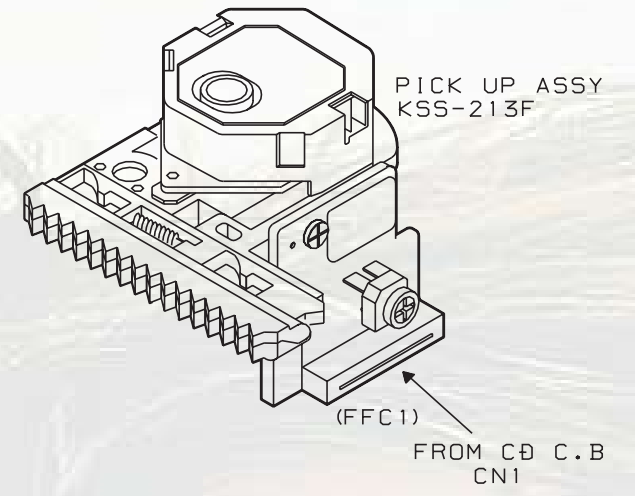
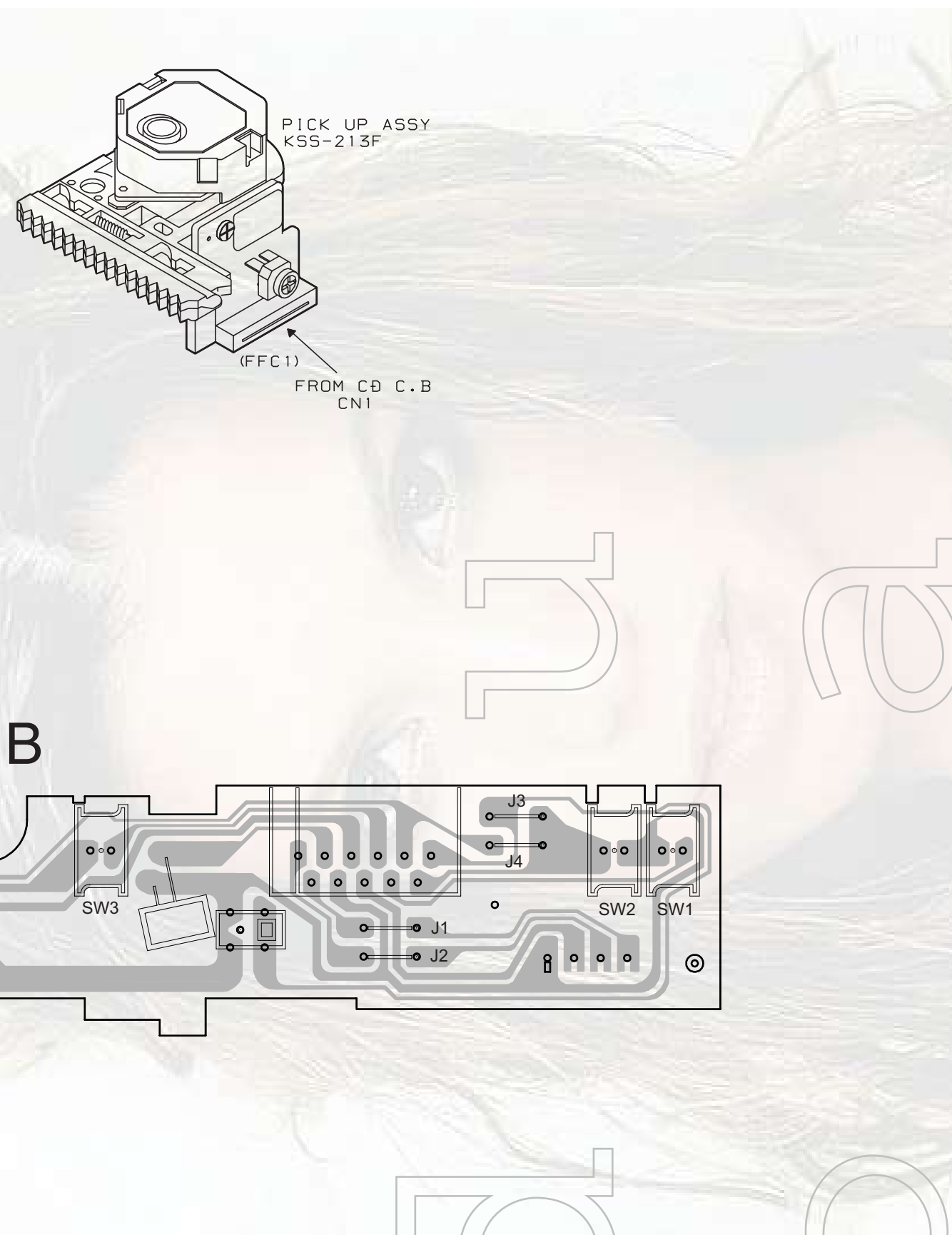

DECK C.B

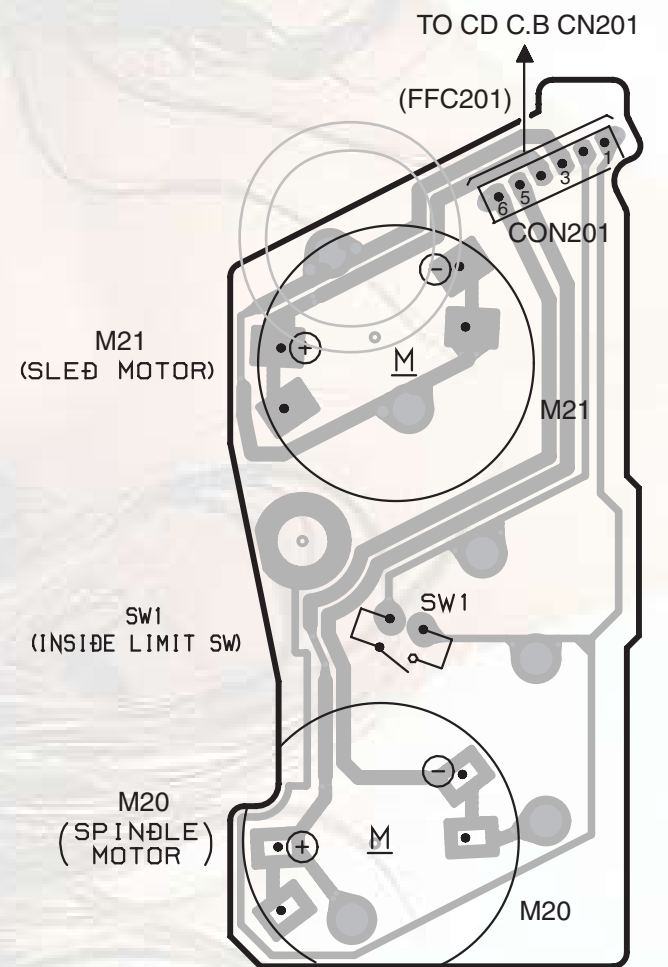
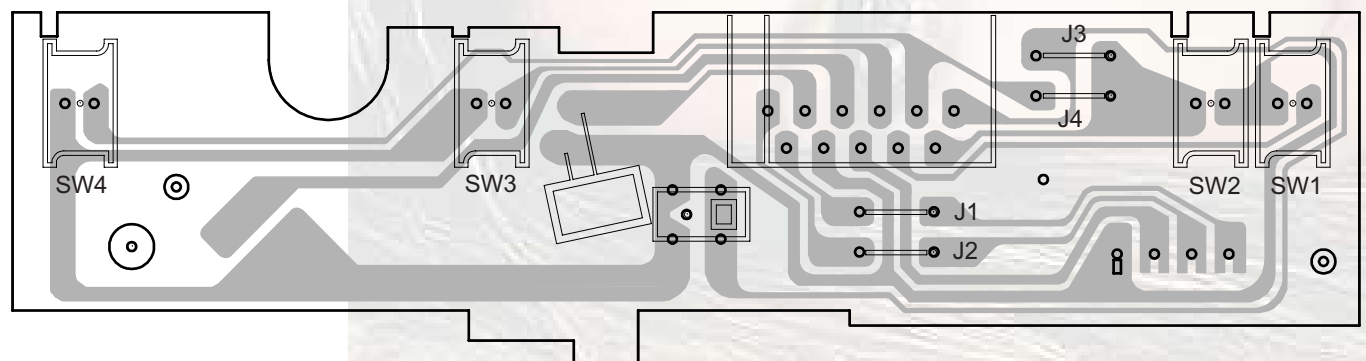

DRIVE C.B

IC BLOCK DIAGRAM

IC, LC72131D-N

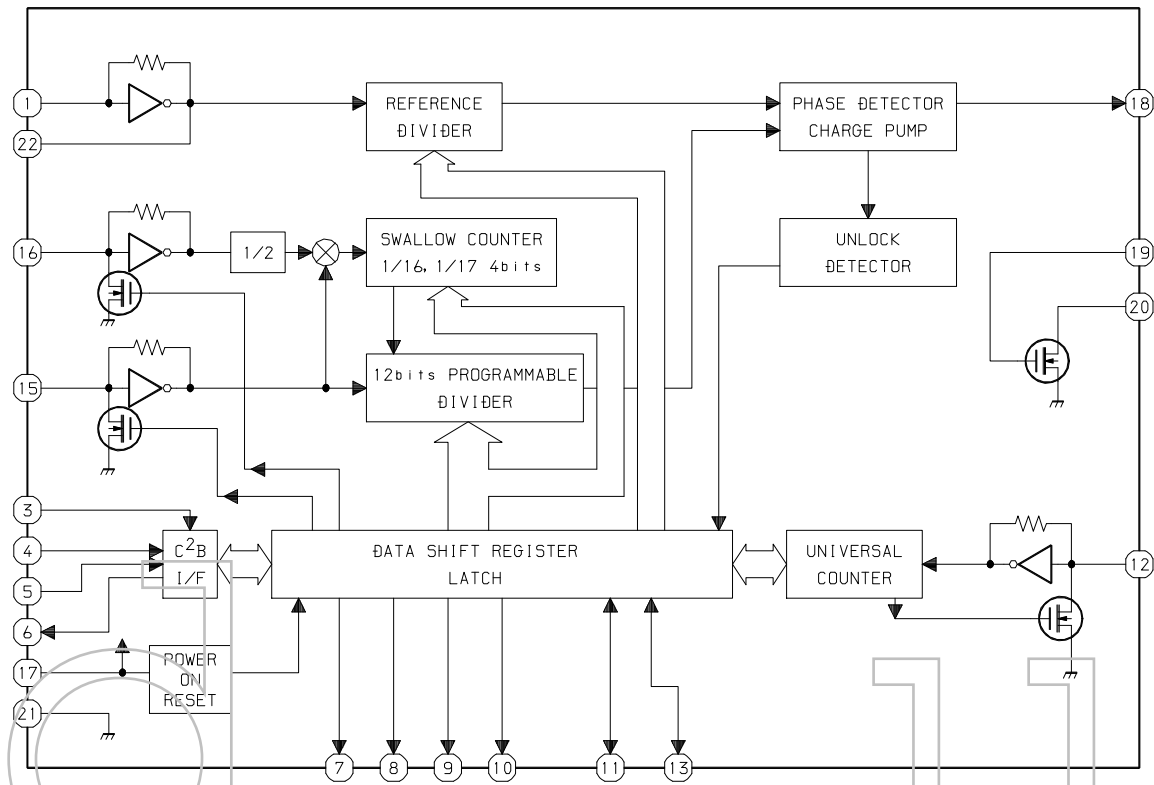

IC, BA5826FP

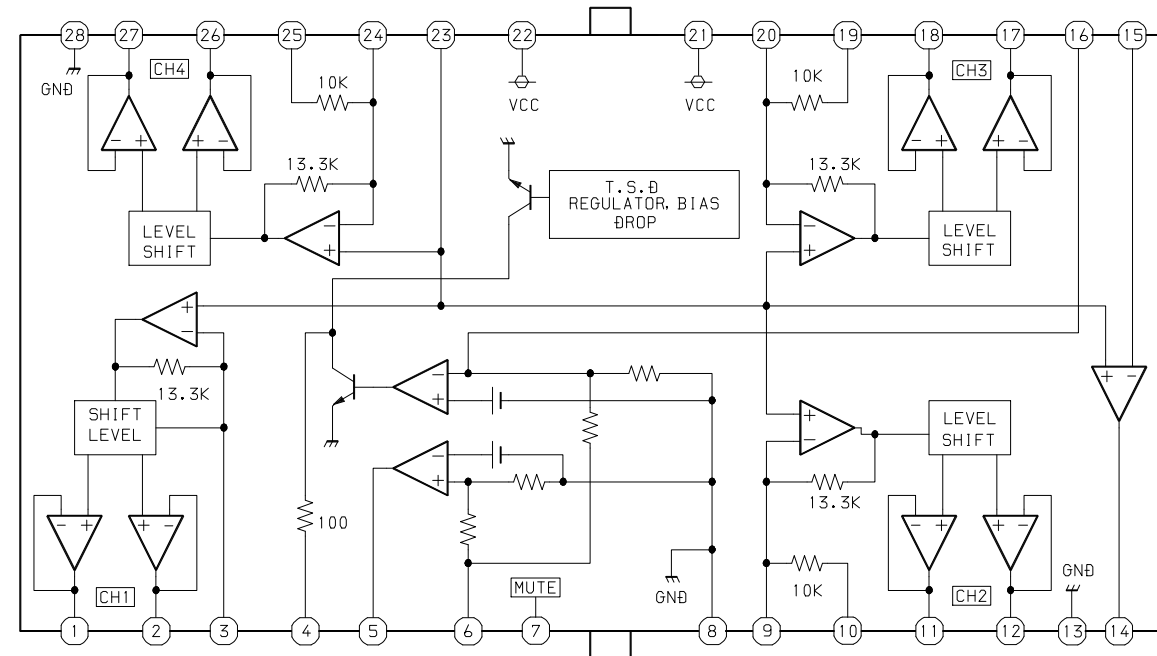

IC, BD3881FV

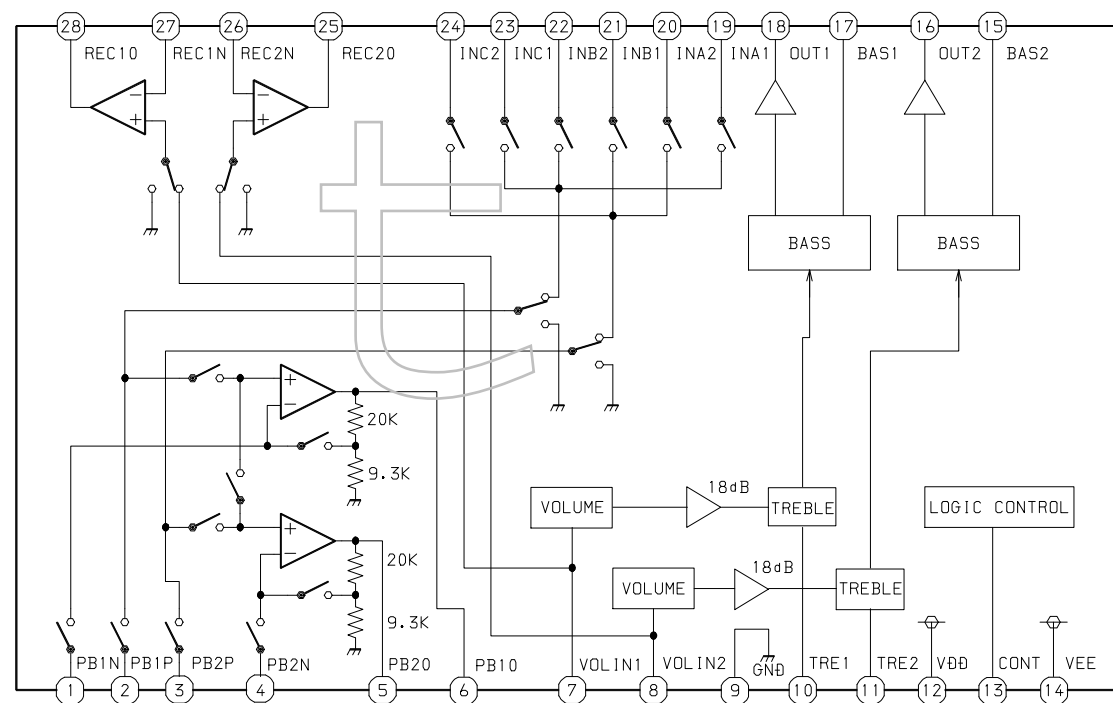

IC, LA1845N-A

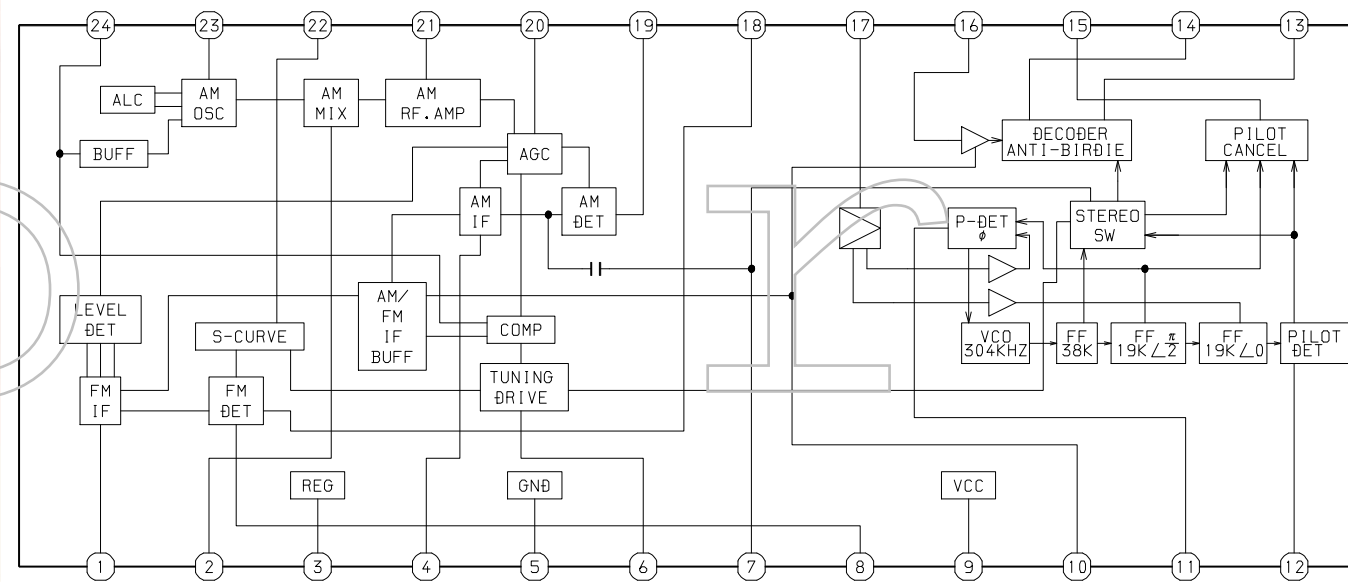

IC, BU1920FS

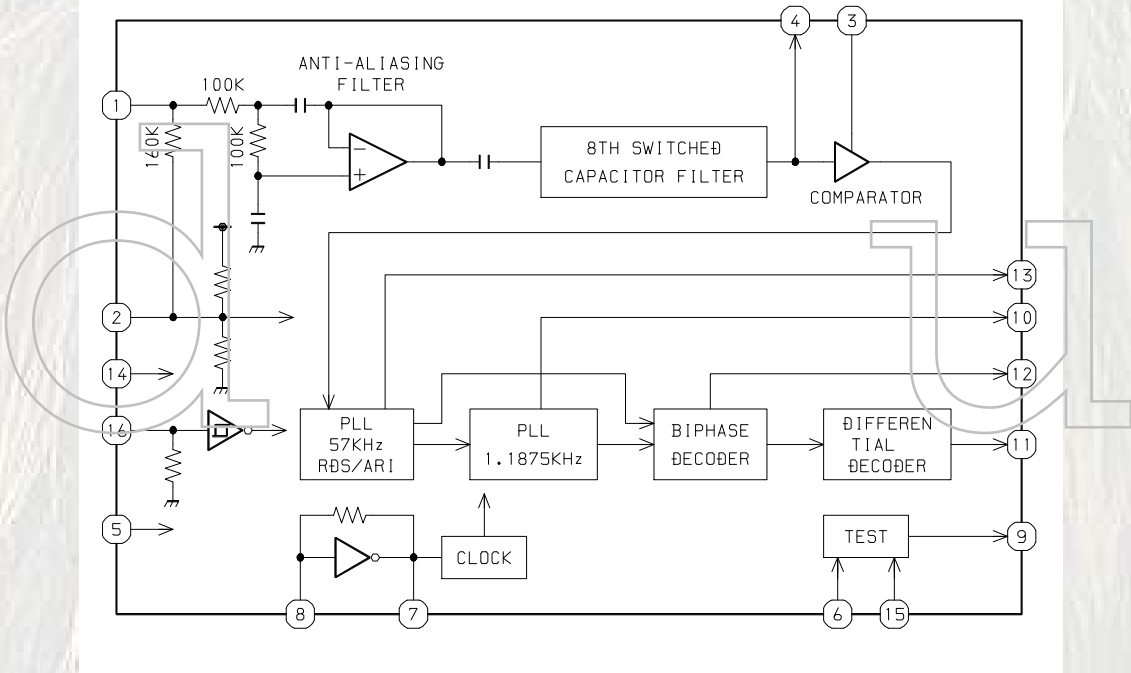

IC, TA7291S

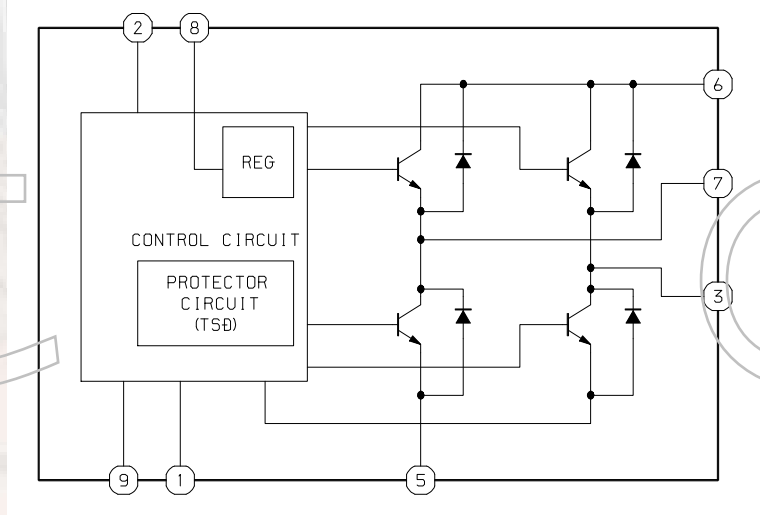

FL (11 - BT - 193GNK) GRID ASSIGNMENT AND ANODE CONNECTION
 GRID ASSIGNMENT

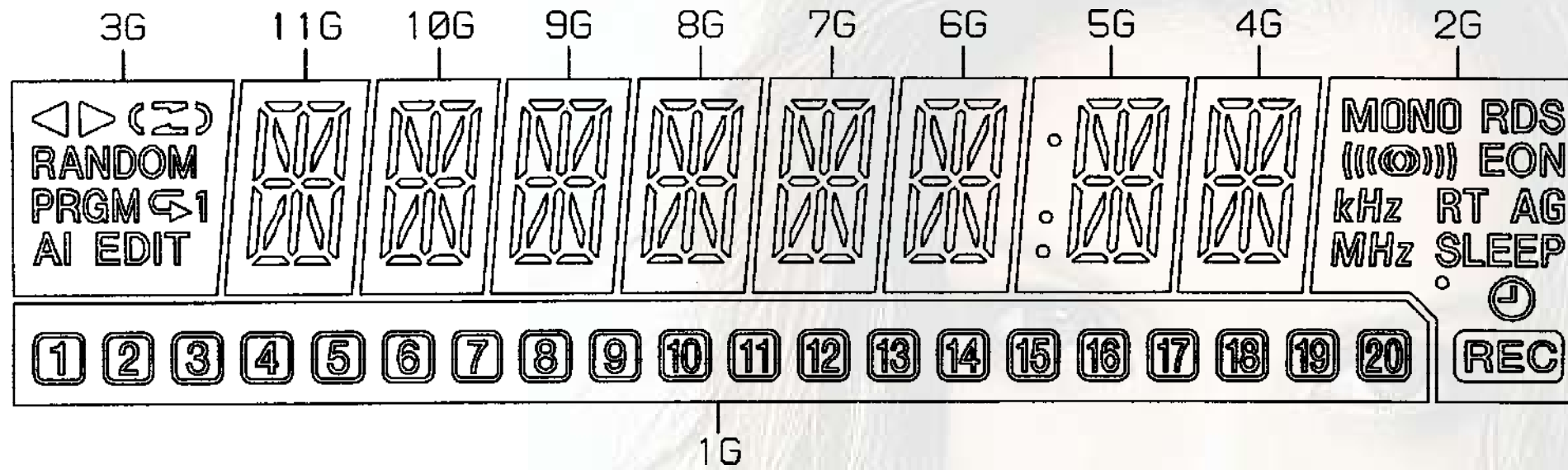

col1 O
 col2 O
 Dp O
 (5G)

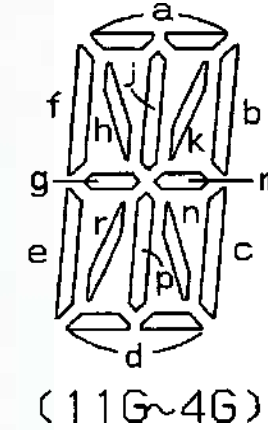

ANODE CONNECTION

	11G	10G	9G	8G	7G	6G	5G	4G	3G	2G	1G
P1	-	-	-	-	-	-	-	-	▶	MONO	20
P2	d	d	d	d	d	d	d	d	◀	(((O)))	19
P3	n	n	n	n	n	n	n	n	RANDOM	MHz	18
P4	p	p	p	p	p	p	p	p	PRGM	kHz	17
P5	r	r	r	r	r	r	r	r	↻	○	16
P6	e	e	e	e	e	e	e	e	1	RDS	15
P7	c	c	c	c	c	c	c	c	AI	EON	14
P8	g	g	g	g	g	g	g	g	EDIT	RT	13
P9	m	m	m	m	m	m	m	m	-	AG	12
P10	f	f	f	f	f	f	f	f	(SLEEP	11
P11	b	b	b	b	b	b	b	b	~	⌚	10
P12	k	k	k	k	k	k	k	k)	REC	9
P13	j	j	j	j	j	j	j	j	-	-	8
P14	h	h	h	h	h	h	h	h	-	-	7
P15	a	a	a	a	a	a	a	a	-	-	6
P16	-	-	-	-	-	-	col1	-	-	-	5
P17	-	-	-	-	-	-	col2	-	-	-	4
P18	-	-	-	-	-	-	Dp	-	-	-	3
P19	-	-	-	-	-	-	-	-	-	-	2
P20	-	-	-	-	-	-	-	-	-	-	1

IC DESCRIPTION

IC, LC876764A-5Z31

Pin No.	Pin Name	I/O	Description
1	O-COCK	O	CD control Q code clock signal output.
2	O-RWC	O	CD control command LAT signal output.
3	O-CDIN	O	CD control command data signal output.
4	I-WRQ	I	CD control SCOR signal input.
5	I-DRF	I	CD control focus OK input.
6	I-SQOUT	I	CD control Q code input.
7	ECO-LED	O	Stand by ON/OFF control output.
8	O-MOTOR	O	Motor control output.
9	O-SOL	O	Cassette play control signal output.
10	O-CLK_SHIFT	O	Clock shift output for micro-computer when using tuner.
11	I-RESET	I	Reset input for MICON.
12	NC	-	Connected to pull-up resistor.
13	O-DECK	O	Deck control output.
14	VSS1	-	Connected to GND.
15	XIN	I	Main clock input 9.43MHz.
16	XOUT	O	Main clock output 9.43MHz.
17	VDD1	-	Digital power supply pin.
18	I-HOLD	I	Hold input.
19	I-VOL	I	Volume control input.
20	NC	-	Connected to pull-up resistor.
21	I-SW_TP	I	Deck mechanism SW AD input.
22	I-KEY2	I	Key AD input 2.
23	I-KEY1	I	Key AD input 1.
24	I-CDTSW	I	CD mecha switch input.
25	I-RDS_SIG	I	RDS signal input.
26	I-AS	-	Cassette deck AS switch signal input.
27	I-STOP	-	Connected to pull-up resistor.
28	I-RDCL	I	RDS clock signal input.
29	I-RMC	I	System remote control signal input.
30	OPEN	-	Not used.
31	CLOSE	-	Not used.
32	NC	-	Not connected.
33	NC	-	Not connected.
34	O-G1	O	VFD driver control data signal output.
35	O-G2	O	VFD driver control data signal output.
36	O-G3	O	VFD driver control data signal output.
37	O-G4	O	VFD driver control data signal output.
38	O-G5	O	VFD driver control data signal output.
39	O-G6	O	VFD driver control data signal output.
40	O-G7	O	VFD driver control data signal output.
41	O-G8	O	VFD driver control data signal output.

Pin No.	Pin Name	I/O	Description
42	O-G9	O	VFD driver control data signal output.
43	O-G10	O	VFD driver control data signal output.
44	O-G11	O	VFD driver control data signal output.
45	O-P1	O	VFD driver control data signal output.
46	VDD3	-	Digital power supply pin.
47	O-P2	O	VFD driver control data signal output.
48	O-P3	O	VFD driver control data signal output.
49	O-P4	O	VFD driver control data signal output.
50	O-P5	O	VFD driver control data signal output.
51	VFE	-	Connected to GND.
52	O-P6	O	VFD driver control data signal output.
53	O-P7	O	VFD driver control data signal output.
54	O-P8	O	VFD driver control data signal output.
55	O-P9	O	VFD driver control data signal output.
56	O-P10	O	VFD driver control data signal output.
57	O-P11	O	VFD driver control data signal output.
58	O-P12	O	VFD driver control data signal output.
59	O-P13	O	VFD driver control data signal output.
60	O-P14	O	VFD driver control data signal output.
61	O-P15	O	VFD driver control data signal output.
62	O-P16	O	VFD driver control data signal output.
63	O-P17	O	VFD driver control data signal output.
64	O-P18	O	VFD driver control data signal output.
65	O-P19	O	VFD driver control data signal output.
66	O-P20	O	VFD driver control data signal output.
67	I-FMW	I	FM selection initialisation resistor connect. (Not used)
68	I-LW	I	LW selection initialisation resistor connect.
69	NC	-	Not connected.
70	I-AM10K	I	AM(10k) selection initialisation resistor connect. (Not used)
71	I-RDS	I	FM(RDS) selection initialisation resistor connect.
72	VDD4	-	Digital power supply pin.
73	D-VDD	-	Not used.
74	EZK-VDD	-	Not used.
75	IN-ECO	I	Eco-mode input. (Not used)
76	NC	-	Not connected.
77	NC	-	Not connected.
78	NC	-	Not connected.
79	NC	-	Not connected.
80	NC	-	Not connected.
81	NC	-	Not connected.
82	NC	-	Not connected.

Pin No.	Pin Name	I/O	Description
83	NC	-	Not connected.
84	NC	-	Not connected.
85	KSCAN	I	Initial scan input.
86	O-MUTE	O	Mute signal output.
87	O-BIAS	O	Bias ON/OFF output.
88	O-TU_ON	O	Tuner power supply ON/OFF output.
89	AVSS	-	Connected to GND.
90	VDD2	-	Digital power supply pin.
91	I-RDDA	I	RDS data input.
92	I-ST	I	Stereo/Mono control signal input.
93	I-TU/IFC	I	Tuner SD detection input/Tuner IF count input.
94	I-TMBASE	I	Reference clock input for timer switch.
95	O-PLL CE	O	Tuner PLL IC chip enable output.
96	O-PLL CLK	O	PLL IC clock output.
97	O-MA DATA	O	BD3881FV (VOL & FUNC) control data output.
98	O-REC	O	Cassette deck REC/PLAY control output.
99	O-POWER	O	Power control ON/OFF output.
100	NC	-	Not connected.

IC, LC78646E

Pin No.	Pin Name	I/O	Description
1	SLCO	O	Slice level control output.
2	SLCIST	I	Connection terminal for current electricity setting of SLCO output.
3	EFMIN	I	RF signal input terminal.
4	RF	O	RF signal monitor terminal.
5	RFVDD	-	RF current electricity terminal.
6	RFVSS	-	RF grounding terminal. (Connected to 0 V)
7	FIN1	I	A+C signal input terminal.
8	FIN2	I	B+D signal input terminal.
9	TIN1	I	E signal input terminal.
10	TIN2	I	F signal input terminal.
11	VREF	O	VREF voltage output terminal.
12	REFI	I	Reference voltage setting terminal.
13	FE	O	FE signal monitor terminal.
14	TEC	O	TE signal LPF condenser connection terminal.
15	TE	O	TE signal monitor terminal. (Not used)
16	RFMON	O	RF internal signal monitor terminal. (Not used)
17	JITTC	-	Jitter detection condenser connection terminal.
18	ADAVDD	-	Servo A/D, D/A power supply terminal.
19	ADAVSS	-	Servo A/D, D/A grounding terminal. (Connected to 0 V)
20	TDO	O	Tracking control output terminal. D/A output.

Pin No.	Pin Name	I/O	Description
21	FDO	O	Focus control output terminal. D/A output.
22	SPDO	O	Spindle control output terminal. D/A output.
23	SLDO	O	Sled control output terminal. D/A output.
24	GPDAC	O	Servo D/A common output terminal. (Not used)
25	CONT4	I/O	Common input/output terminal 4. (Used as a CD driver mute pin)
26	CONT5	I/O	Common input/output terminal 5. (Not used)
27	SBCK/CONT6	I/O	Common input/output terminal 6, or sub code read clock input terminal. (Used as a CD pickup inside limit switch)
28	SBCK/FG	I	Sub code read clock input terminal / FG signal input terminal / External emphasis setting terminal. Terminal function is decided by command. (Connected to 0 V)
29	DEFECT	O	Defect terminal. (Not used)
30	V/P	O	Automatic switching monitor output terminal for rough servo/phase control. "H"=Servo, "L"=Phase servo. (Not used)
31	FSEQ	O	Sync signal detection output terminal. "H"=Sync signal detected from EFM signal and internally generated sync signal are agreed. (Not used)
32	MONH1	O	Internal signal monitor terminal 1.
33	MONI2	O	Internal signal monitor terminal 2.
34	MONI3	O	Internal signal monitor terminal 3.
35	MONI4	O	Internal signal monitor terminal 4.
36	MONI5	O	Internal signal monitor terminal 5.
37	VSS1	-	Digital grounding terminal. (Connected to 0 V)
38	VDD	-	Digital power supply terminal.
39	DOUT	O	Digital OUT output terminal. (EIAJ format) (Not used)
40	TEST	I	Test input terminal. (Connected to GND)
41	LVDD	-	L channel power supply terminal.
42	LCHO	O	L channel output terminal.
43	LVSS	-	L channel grounding terminal. (Connected to 0 V)
44	RVSS	-	R channel grounding terminal. (Connected to 0 V)
45	RCHO	O	R channel output terminal.
46	RVDD	-	R channel power supply terminal.
47	XVDD	-	Crystal oscillation power supply terminal.
48	XOUT	O	Connection terminal for 16.9344MHz crystal oscillation.
49	XIN	I	
50	FSX/16MIN	I/O	7.35kHz sync signal output terminal. Or external clock input terminal for DF, DAC. (Not used)
51	XVSS	-	Grounding terminal for crystal oscillation. (Connected to 0 V)
52	C2F	O	C2 flag output terminal. (Not used)
53	EFLG	O	C1 and C2 correction monitor terminal. (Not used)
54	16MOUT	O	16.9344MHz output terminal. (Not used)
55	ASLRCK	I	L/R clock input terminal. (Connected to 0 V)
56	ASDACK	I	Bit clock input terminal. (Connected to 0 V)
57	ASDFIN	I	L/R channel data input terminal. (Connected to 0 V)

Pin No.	Pin Name	I/O	Description
58	LRSY	O	L/R clock output terminal. (Not used)
59	DATACK	O	Bit clock output terminal. (Not used)
60	DATA	O	L/R channel data output terminal. (Not used)
61	CE	I	Chip enable signal input terminal.
62	CL	I	Data transfer clock input terminal.
63	DI	I	Data input terminal.
64	DO	O	Data output terminal. (Nch open drain output)
65	WRQ	O	Interrupt signal output terminal.
66	RES	I	LSI reset input terminal. Set to "L" when power is turned on.
67	DRF	O	Focus ON detection terminal.
68	VDD5	-	Microcomputer interface power supply terminal.
69	VSS2	-	Digital grounding terminal. (Connected to 0 V)
70	CONT3	I/O	Common input/output terminal 3. (Not used)
71	CONT2	I/O	Common input/output terminal 2. (Used as CD close switch)
72	CONT1	I/O	Common input/output terminal 1. (Used as CD open switch)
73	PDO1	O	Phase comparison output terminal 1 for internal VCO control.
74	PDO2	O	Phase comparison output terminal 2 for internal VCO control.
75	VVSS	-	Grounding terminal for internal VCO. (Connected to 0 V)
76	PCKIST	I	Resistance connection terminal for PDO1 and 2 output power supply setting.
77	VVDD	-	Internal VCO power supply terminal.
78	FR	I	Resistance connection terminal for internal VCO frequency range setting.
79	LDS	O	Laser power detection signal input terminal.
80	LDD	O	Laser power control signal output terminal.

VOLTAGE CHART

COMMON PARTS

	B	C	E		B	C	E
Q111 2SB1370	22.5	12.1	23.1	Q216 2SA1162GR	0	23.8	0
Q102 2SC5343GL	0.7	21.8	0	Q212 2SD1933	1.0	22.4	0
Q112 2SC2712GR	0.6	1.1	0	Q224 2SC2712GR	0.1	1.0	-0.4
Q100 2SC2712GR	0.7	0.1	0	Q226 2SC2712GR	-0.4	1.0	-1.0
Q104 2SA1980G	11.4	12.1	12.1	Q204 2SA1162GR	0	-22.8	0.6
Q103 2SC3052	11.6	11.4	11	Q202 2SA1162GR	0	-22.4	0.6
Q105 2SA19790/Y	27.6	-41.3	-27	Q213 2SB1342	-1.0	-23.8	0
Q109 2SC2712GR	0	0.6	0	Q221 2SC534GL	23.2	-1.0	-23.8
Q107 2SC2712GR	0.6	0	0	Q209 2SC5343GL	-22.1	1.0	-23.2
Q108 2SA1162GR	-0.6	0	-0.6	Q207 2SC2712GR	-22.7	-23	-27
Q106 2SC2712GR	0	3.1	0	Q205 2SC2712GR	-22.7	-23.3	-23.8
Q206 2SC2712GR	-23.0	-22.4	-23.6	Q215 2SA1162GR	0	-23.3	0
Q208 2SC2712GR	-23.0	-22.6	-23.6	Q211 2SD1933	1.0	23.1	0
Q210 2SC5343GL	-22.4	-23.0	1.0	Q225 2SC2712GR	-0.4	1.0	-1.0
Q220 2SC5343GL	-23.0	-1.0	-23.6	Q223 2SC2712GR	0.1	1.0	-0.4
Q222 2SC5343GL	-23.0	-1.0	-23.6	Q203 2SA1162GR	0	-23.0	0.6
Q214 2SB1342	-1.0	5.0	0	Q4 2SA1162GR	0	-23.0	0.6
Q217 2SA1980G	-12.0	-24.0	-12.0	Q261 2SC2712GR	1.5	0	0
Q218 2SC2712GR	-11.7	-24.4	-24.4	Q262 2SC2712GR	1.5	0	0
Q262 2SC2712GR	0.8	-0.5	-0.2	Q219 2SC5343GL	-23.2	-1.0	24.0
Q310 2SC2712GR	0.6	0	0	Q301 2SC2712GR	2.4	10.1	1.8
Q316 DTA114EK	0	5.0	5.1	Q314 2SA1980G	10.7	5.8	11.4
Q304 2SC2712GR	0.5	2.4	0				

TAPE SECTION

	S	G	D		B	C	E
Q305 2SK2158	-7.0	-22.2	0	Q2 2SA1162GR	-0.6	0	0
Q308 2SK2158	-7.0	-22.2	-0.2	Q5 DTA124EUA	0	-0.6	0.1
Q307 2SK2158	-7.0	-22.2	-0.2	Q302 2SA1296GR	11.9	11.9	12.0
				Q303 2SA1296GR	11.9	11.9	0
				Q306 DTA124EUA	0	-11.8	0.1
				Q309 2SA1162GR	-0.6	0	0

RECORD SECTION

	S	G	D		B	C	E
Q452 2SK2158	0	0.3	28.0	Q450 2SC3052	1.3	2.7	0.7
				Q451 2SC5343GL	0.7	3.9	0
				Q453 2SC5343GL	3.8	11.8	4.4
				Q454 2SC5343GL	3.8	11.8	4.4

CD SECTION

	B	C	E
Q201 2SA1980G	5.1	3.3	5.9
Q1 2SA1980G	4.0	3.0	4.7
Q101 2SC5343GL	4.0	4.7	3.3

TUNER SECTION

	B	C	E		B	C	E
Q981 2SA1980G	10.46	8.20	11.20	Q836 SRA2207S	0.83	8.00	8.20
Q982 2SC5343SF/S(G)	5.30	10.46	4.70	Q904 2SC2620B	0	0	2.00
Q983 2SC5343SF/S(G)	5.26	8.20	4.70	Q902 2SC2620B	0	8.17	0
Q835 2SC27140	6.38	4.60	3.80	Q903 2SC2620B	0.70	0	5.90
Q951 RT1P141C	0.70	8.20	8.20	Q905 2SC2620B	0.10	6.10	0.10
Q952 2SD1306NE07TL	0.70	0	0	Q948 2SD1306NE07TL	0.70	0	0

	S	G	D
Q901 2SK360E	0	6.30	0

COMMON PARTS (IC)

IC102, KIA7806API

Pin No.	1	2	3
Voltage	5.9	0	12.1

IC601, BD3881FV

Pin No.	1	2	3	4	5	6	7	8	9	10
Voltage	0	0	0	0	0	0	0	0	0	0
Pin No.	11	12	13	14	15	16	17	18	19	20
Voltage	0	4.8	0.1	-4.8	0	0	0	0	0	0
Pin No.	21	22	23	24	25	26	27	28		
Voltage	0	0	0	0	0	0	0	0		

IC301, LC876764A-5Z31

Pin No.	1	2	3	4	5	6	7	8	9	10
Voltage	5.2	0	5.1	5.2	0	5.1	3.7	0.4	12.0	0
Pin No.	11	12	13	14	15	16	17	18	19	20
Voltage	5.0	5.1	0	0	2.3	2.3	5.0	3.0	4.9	5.1
Pin No.	21	22	23	24	25	26	27	28	29	30
Voltage	1.9	0	3.1	0	0	1.9	5.1	0	4.9	0
Pin No.	31	32	33	34	35	36	37	38	39	40
Voltage	0	0	0	-26.7	-27.0	-26.7	-26.7	-26.7	-26.7	-26.7
Pin No.	41	42	43	44	45	46	47	48	49	50
Voltage	-26.7	-26.7	-26.7	-26.7	-26.7	5.4	-26.7	-26.7	-26.7	-26.7
Pin No.	51	52	53	54	55	56	57	58	59	60
Voltage	0	-26.7	-26.7	-26.7	-26.7	-26.7	-26.7	-26.7	-26.7	-26.7
Pin No.	61	62	63	64	65	66	67	68	69	70
Voltage	-26.7	-26.7	-26.7	-26.7	-26.7	-26.7	0	5.2	-0.1	0
Pin No.	71	72	73	74	75	76	77	78	79	80
Voltage	5.1	5.4	0	0	0	0	0	0	0	0
Pin No.	81	82	83	84	85	86	87	88	89	90
Voltage	0	0	0	0	0	0	0	0	0	0
Pin No.	91	92	93	94	95	96	97	98	99	100
Voltage	0.1	0	0	0	0	0	0	0	5.2	0

CD SECTION (IC)

IC10, TA7291S

Pin No.	1	2	3	4	5	6	7	8	9
Voltage	0	5.9	0.7	0	0	5.9	0.7	2.9	0

IC202, BA5826FP

Pin No.	1	2	3	4	5	6	7	8	9	10
Voltage	2.1	2.8	1.6	0.9	5.0	3.3	3.3	0	0	1.6
Pin No.	11	12	13	14	15	16	17	18	19	20
Voltage	2.4	2.4	0	1.6	1.6	4.7	2.4	2.5	1.6	1.6
Pin No.	21	22	23	24	25	26	27	28		
Voltage	5.6	0	1.6	1.6	1.6	2.3	2.6	0		

IC101, LC78646E

Pin No.	1	2	3	4	5	6	7	8	9	10
Voltage	1.6	1.0	0	1.6	3.2	0	1.6	1.6	1.6	1.6
Pin No.	11	12	13	14	15	16	17	18	19	20
Voltage	1.6	1.6	1.6	1.6	1.6	1.0	0.9	3.3	0	0
Pin No.	21	22	23	24	25	26	27	28	29	30
Voltage	1.5	1.8	1.6	1.6	3.3	0	3.3	0	0	0
Pin No.	31	32	33	34	35	36	37	38	39	40
Voltage	3.3	0	0	0	1.6	1.6	0	3.3	1.5	0
Pin No.	41	42	43	44	45	46	47	48	49	50
Voltage	3.2	1.6	0	0	1.6	3.2	3.2	0	0	0
Pin No.	51	52	53	54	55	56	57	58	59	60
Voltage	0	0	0	0	0	0	0	1.6	1.1	1.6
Pin No.	61	62	63	64	65	66	67	68	69	70
Voltage	0.6	4.8	5.1	4.8	4.3	5.1	5.1	5.1	0	0
Pin No.	71	72	73	74	75	76	77	78	79	80
Voltage	0	0	1.3	1.3	0	1	3.3	2.5	0.2	2.3

TUNER SECTION (IC)

IC991, LC72131D-N

Pin No.	1	2	3	4	5	6	7	8	9	10
Voltage	2.68	0	0	0.14	0.02	0.01	1.20	8.14	0.04	0.03
Pin No.	11	12	13	14	15	16	17	18	19	20
Voltage	0.02	0	0.03	-0.07	0	2.70	5.56	0.99	0.98	2.71
Pin No.	21	22								
Voltage	0	2.71								

IC801, LA1845N-A

Pin No.	1	2	3	4	5	6	7	8	9	10
Voltage	2.32	8.12	2.32	2.30	0	0.03	0.04	8.12	8.13	0.43
Pin No.	11	12	13	14	15	16	17	18	19	20
Voltage	7.08	7.17	3.49	3.47	0	2.32	2.06	3.46	0	36.90
Pin No.	21	22	23	24						
Voltage	1.78	1.80	8.16	6.64						

ADJUSTMENT

< FRONT SECTION >

FRONT C.B (COMPONENT SIDE)

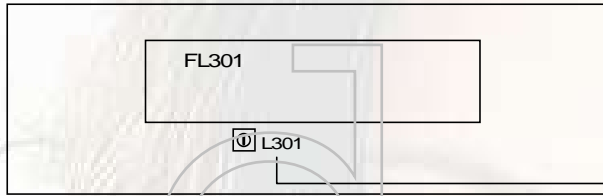

FRONT C.B (CONDUCTOR SIDE)

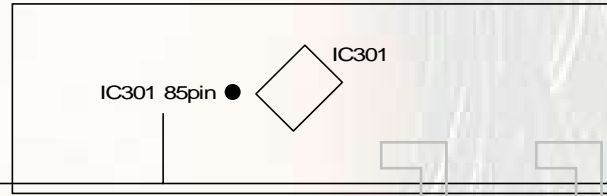

1. CLOCK ADJUSTMENT

Requirements

Test point: TP1(IC301 85pin), GND

Adjustment point: L301

- 1) While pressing and holding down the POWER button and the TUNER / BAND button, insert the AC plug to outlet.
- 2) Adjust L301 so that the oscilloscope indicates the frequency within $320.5\text{Hz} \pm 1\text{Hz}$.

< DECK SECTION >

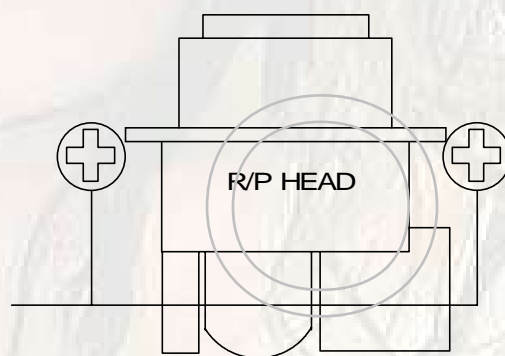
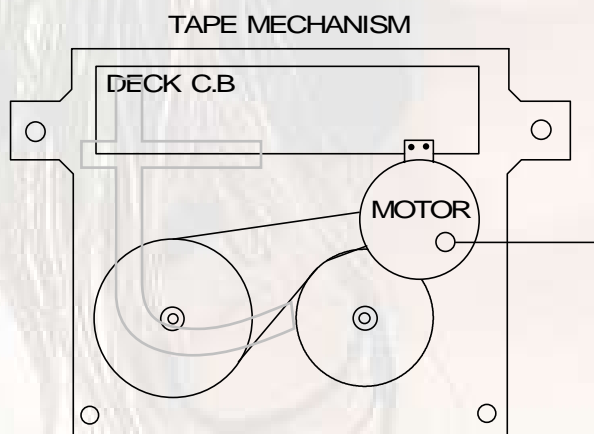
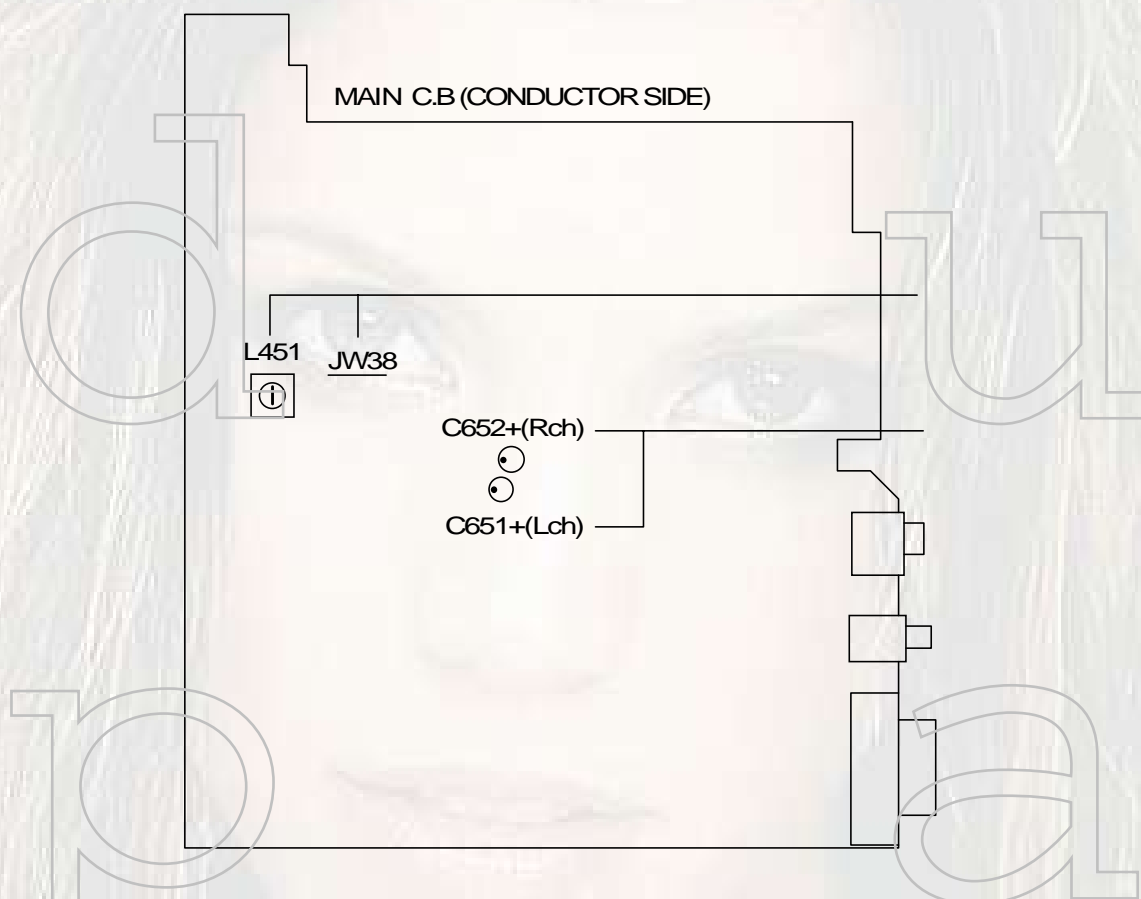

1. TAPE SPEED ADJUSTMENT

Requirements

Measuring equipments : Wow & flutter meter (frequency counter)

Test Tape: TTA-100 (3kHz)

Test point: C651(Lch),C652(Rch),GND

Adjustment point : Tape speed adjustment point (motor)

- 1) Connect Test point to the Wow & flutter meter.
- 2) Insert the test tape (TTA-100), play back center of the tape and adjust the motor adjustment point until it becomes 3,000Hz +3 / -2%.

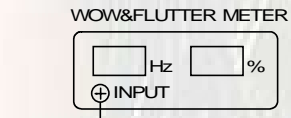

2. WOW & FLUTTER CHECK

Requirements

Test tape: TTA-100 (3kHz)

Test point: C651(Lch),C652(Rch),GND

- 1) Connect the Test point to the Wow & flutter meter.
- 2) Set the indicator to JIS and the mode to W RMS (WTD) of the Wow & flutter meter.
- 3) Play back the center of the test tape (TTA-100) and check that it is below 0.25%.

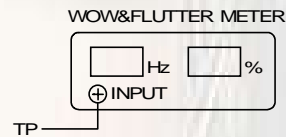

3. HEAD AZIMUTH ADJUSTMENT

Requirements

Measuring equipment: Oscilloscope

Test Tape: TTA-330 (8kHz)

Test point: C651(Lch),C652(Rch),GND

Adjustment point: Head azimuth screw

- 1) Connect the Test point to the oscilloscope of CH1 and CH2.
- 2) Set the V mode of the oscilloscope to ADD.
- 3) Insert the test tape (TTA-330) , play back the center of the tape and adjust the head azimuth screw until the waveform of the oscilloscope has reached the maximum when playing back at 10kHz.
- 4) After the adjustment, bond lock (1600B) the screw.

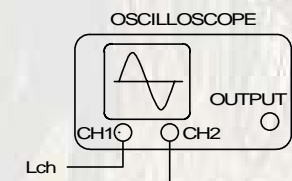

4. REC. BIAS FREQUENCY ADJUSTMENT

Requirement

Measuring equipment: Frequency counter

Test point: JW38, GND

Adjustment point: L451

- 1) Connect the JW38 to the frequency counter.
- 2) Set the recording condition to the main unit.
- 3) Adjust the L451 until it becomes 85kHz +/- 0.5kHz.

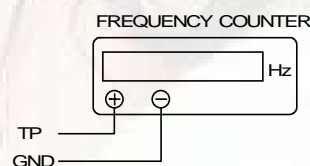

< TUNER SECTION >

TUNER C.B (COMPONENT SIDE)

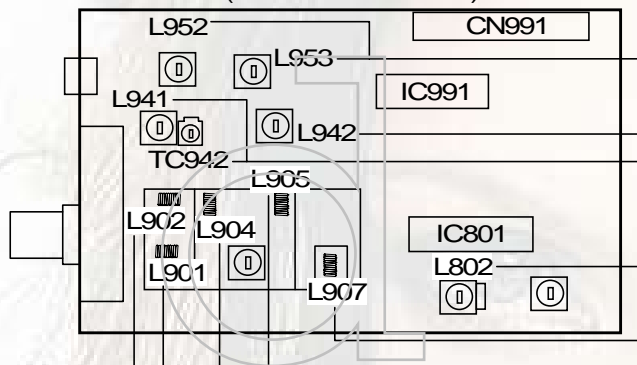

TUNER C.B (CONDUCTOR SIDE)

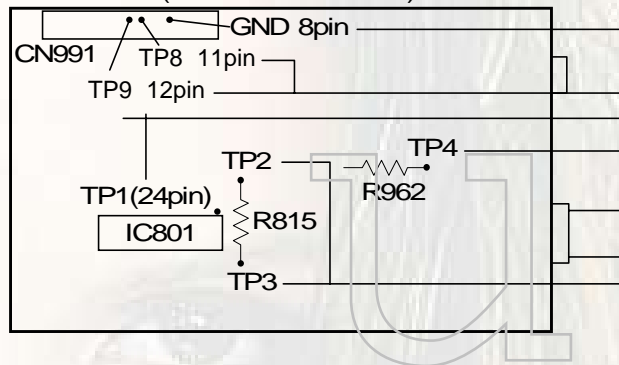

1.CLOCK CHECK

Requirement

Measuring equipment: Frequency counter

Test point: TP1 (CLK), GND

- (1) Adjust the reception frequency of the main unit to 1710kHz.
- (2) Check that the test point frequency is $2160\text{kHz} \pm 0.045\text{kHz}$.

FREQUENCY COUNTER

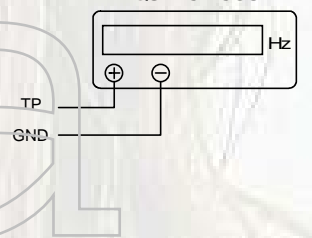

2.VT ADJUSTMENT (LW)

Requirement

Measuring equipment: Digital multi-meter

Test point: TP4 (R962), GND

Adjustment point: L942

- (1) Adjust the reception frequency of the main unit to 144kHz.
- (2) Adjust L942 until the test point voltage (VT) is $1.3\text{V} \pm 0.05\text{V}$.

DIGITAL MULTIMETER

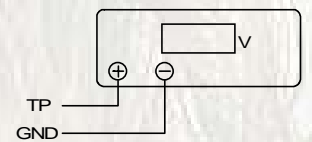

3.VT CHECK (MW)

Requirement

Measuring equipment: Digital multi-meter

Test point: TP4 (R962), GND

- (1) Adjust the reception frequency of the main unit to 531kHz.
- (2) Check that the test point (VT) voltage is about 0.5V.
- (3) Adjust the reception frequency of the main unit to 1602kHz.
- (4) Check that the test point (VT) voltage is below 8.0V.

DIGITAL MULTIMETER

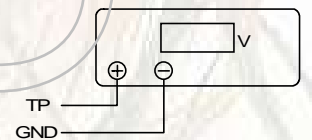

4.VT ADJUSTMENT (FM)

Requirement

Measuring equipment: Digital multi-meter

Test point: TP4 (R962), GND

Adjustment point: L907

- (1) Adjust the reception frequency of the main unit to 108.0MHz.
- (2) Adjust L907 until the test point voltage (VT) is $7.0\text{V} \pm 0.1\text{V}$.
- (3) Adjust the reception frequency of the main unit to 87.5MHz.
- (4) Check that the test point (VT) voltage is about 0.5V.

DIGITAL MULTIMETER

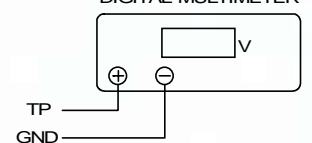

5.DC BALANCE CHECK (FM)

Requirement

Measuring equipment: Digital multi-meter

Test point: TP2, 3

- (1) Adjust the reception frequency of the main unit to 98.0MHz.
- (2) Check that the test point voltage difference between TP2 and TP3 is $0mV \pm 500mV$.

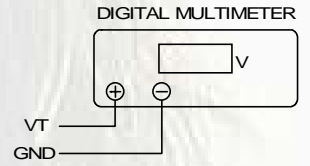

<LW / MW ADJUSTMENT>

For LW / MW adjustment, do wiring and connection as in the following.

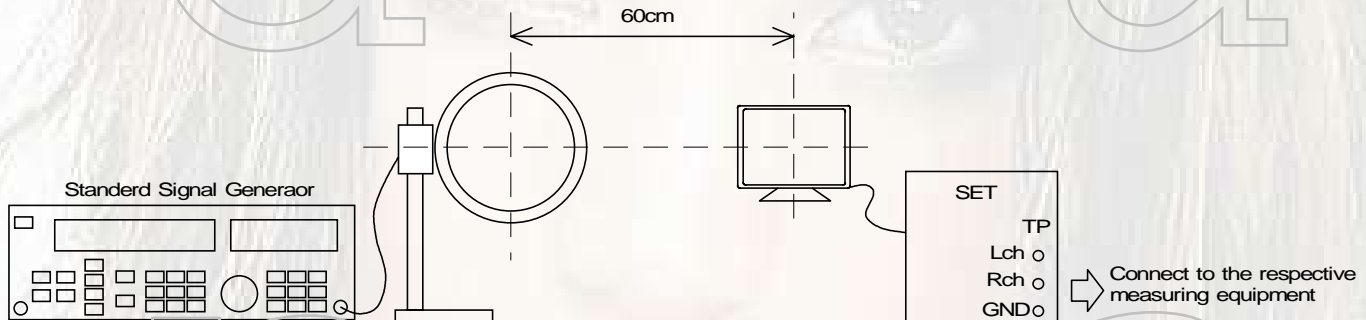

6.IF ADJUSTMENT (MW)

Requirement

Measuring equipment: Oscilloscope or Millivoltmeter

Test point: TP8(Lch), TP9(Rch), GND

Adjustment point: L802

- (1) Adjust the setting of Standard Signal Generator (hereinafter S.S.G.) to 999kHz of 30% variation.
- (2) Adjust the receiving frequency of the main unit at 999kHz.
- (3) While looking at the waveform on the oscilloscope, reduce the output level all the way (till a certain degree of is monitored through the oscilloscope).
- (4) Adjust L802 until the waveform of the oscilloscope reaches the maximum.

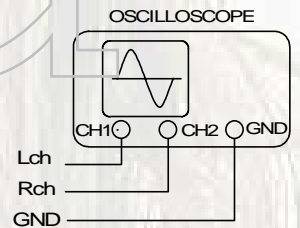

7.TRACKING ADJUSTMENT (MW)

Requirement

Measuring equipment: Millivoltmeter

Test point: TP8(Lch), TP9(Rch), GND

Adjustment point: L952, L953

- (1) Adjust the S.S.G. setting to 999kHz of 30% variation and reduce the output level all the way (till a certain degree of is monitored through the oscilloscope).
- (2) Adjust the reception frequency of the main unit to 999kHz.
- (3) Adjust L952 until the value of the millivoltmeter reaches the maximum.
- (4) Adjust the S.S.G. setting to 603kHz of 30% variation and reduce the output level all the way (till a certain degree of is monitored through the oscilloscope).
- (5) Adjust the reception frequency of the main unit to 603kHz.
- (6) Adjust L953 until the value of the millivoltmeter reaches the maximum.
- (7) Repeat the adjustment 2 or 3 times from step 1 to 6 above.

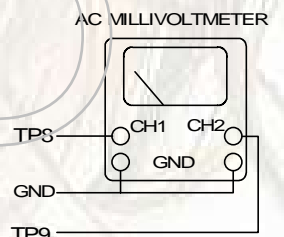

8. TRACKING ADJUSTMENT (LW)

Requirement

Measuring equipment: Millivoltmeter

Test point: TP8(Lch), TP9(Rch), GND

Adjustment point: L941, TC942

- (1) Adjust the S.S.G. setting to 144kHz of 30% variation and reduce the output level all the way (till a certain degree of is monitored through the oscilloscope).
- (2) Adjust the reception frequency of the main unit to 144kHz.
- (3) Adjust L941 until the value of the millivoltmeter reaches the maximum.
- (4) Adjust the S.S.G. setting to 290kHz of 30% variation and reduce the output level all the way (till a certain degree of is monitored through the oscilloscope).
- (5) Adjust the reception frequency of the main unit to 290kHz.
- (6) Adjust TC942 until the value of the millivoltmeter reaches the maximum.
- (7) Repeat the adjustment 2 or 3 times from step 1 to 6 above.

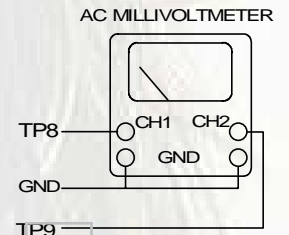

<FM ADJUSTMENT>

For adjusting FM, do wiring function and connection as in the following.

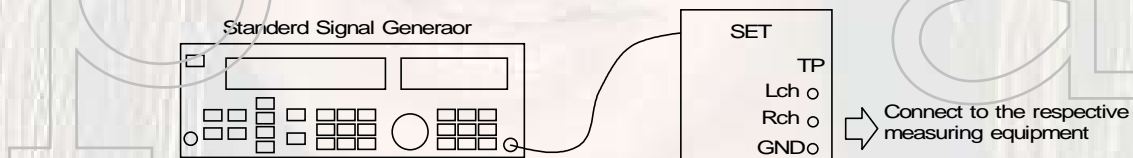

9. TRACKING ADJUSTMENT (FM)

Requirement

Measuring equipment: Millivoltmeter

Test point: TP8(Lch), TP9(Rch), GND

Adjustment point: L905, L904, L902, L901

- (1) Adjust the S.S.G. setting to 144kHz of 30% variation and reduce the output level all the way (till a certain degree of is monitored through the oscilloscope).
- (2) Adjust L905 > L904 > L902 > L901 until the value of the millivoltmeter reaches the maximum.
- (3) Adjust L901 > L902 > L904 > L905 until the value of the millivoltmeter reaches the maximum.
- (4) Repeat the adjustment 2 or 3 times from step 2 to 3 above.

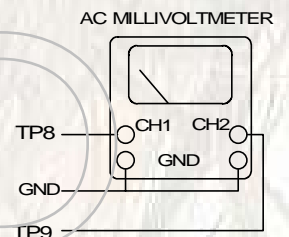

CD C.B (PATTERN SIDE)

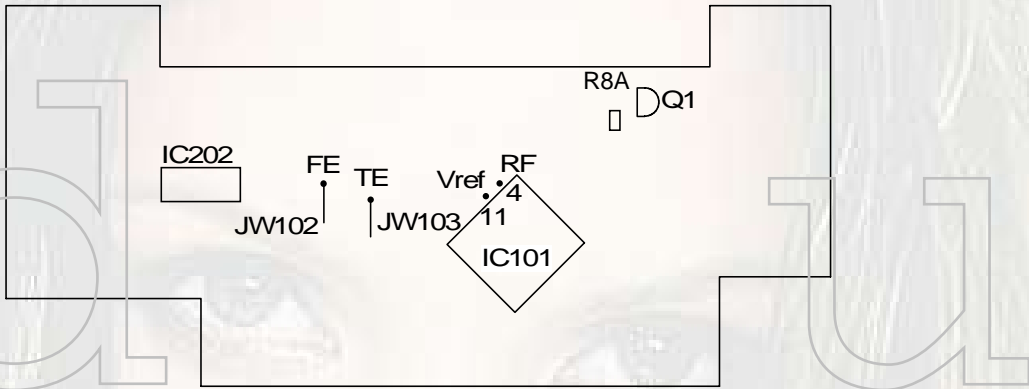

CD CHECK

Perform the adjustments after the main unit enters the test mode.

Place the CD mechanism on level ground.

Equipment and tools required

Measuring equipment

Digital multi-meter

Jitter meter (KIKUSUI 6235)

Test disc: TCD-782

ATD-001

1.RF WAVEFORM CHECK

- 1) Connect oscilloscope to the test point RF and Vref.
- 2) Play back the 2nd track of TCD-782.
- 3) Check that the RF waveform has the maximum amplitude and the center of the wedge waveform has the clear blank.

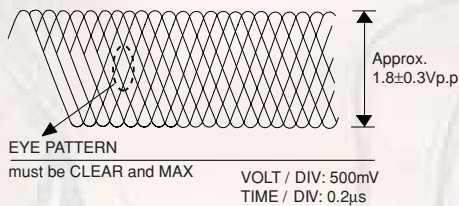
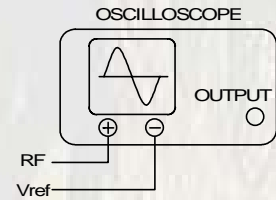

2.JITTER CHECK

- 1) While oscilloscope is kept connected in the same test point as in step2. RF WAVEFORM CHECK, connect the output terminal of an oscilloscope to the input terminal of the jitter meter.
- 2) Set the VOLT range selector of oscilloscope to 500mV range or below.
- 3) Play back 2nd track of TCD-782.
- 4) Check that jitter meter indicates 28.0ns or less.

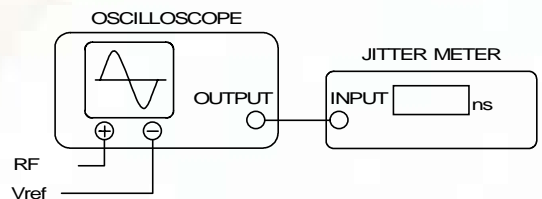

3. TRACKING BALANCE CHECK

- 1) Connect the TE and Vref to the oscilloscope.
- 2) Playback the second track of TCD-782 and press the PAUSE button.
- 3) Check that the traverse waveforms of oscilloscope are up and down symmetrical.

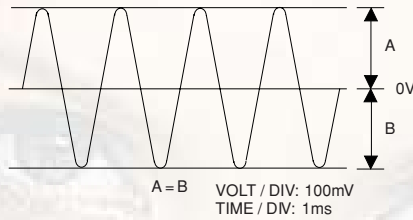
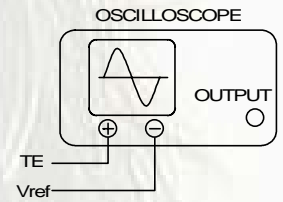

4. PLAY ABILITY CHECK

- 1) Play back the 3rd, 8th and 13th track of ATD-001. Check that the noise does not occur sound skipping does not occur.

5. LASER CURRENT CHECK

*Do not perform this measurement unless the laser is suspected to be defective.

- 1) Connect digital multi-meter across the resistor R8A (3.3ohm).
- 2) Play back the TCD-782 and check the DC voltage value on the digital multi-meter.
- 3) Calculate the laser current (Iop) by dividing the DC voltage across R8A by the resistor value (R8A= 3.3ohm).

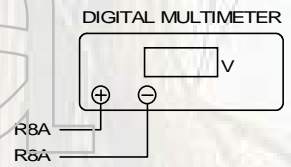

Check that the laser current (Iop) is SPEC value $\pm 10\%$.

EXAMPLE

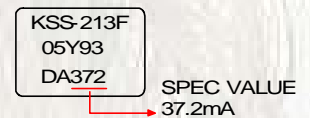

CD TEST MODE

1. How to Start the CD Test Mode

While pressing the CD FUNCTION button, insert the AC plug to the power outlet.
When the test mode started, the message [CD TEST] is displayed.

2. How to Exit the CD Test Mode

Press the POWER button or disconnect the AC plug.

3. Function and Usage of the CD Test Mode

No	Mode	Button for Activation	Display	Operation	Contents
1	Start Mode		All lights are lit.		<ul style="list-style-type: none"> • Microcomputer check
2	Search Mode	STOP button	READING	<ul style="list-style-type: none"> • LD illuminates all the time • Focus search continues operations *1 • Spindle motor continuous kick 	<ul style="list-style-type: none"> • APC circuit check • Laser current measurement • Focus search waveform check
3	Play Mode	PLAY button	Normal	<ul style="list-style-type: none"> • Normal playback • If TOC cannot be read, focus search is continued 	<ul style="list-style-type: none"> • Each servo circuit is checked • DRF check
4	Traverse Mode	PAUSE button	Normal	<ul style="list-style-type: none"> • Tracking servo OFF/ON STOP button to cancel 	<ul style="list-style-type: none"> • Tracking balance check
5	Sled Mode	FF button	CD TEST	<ul style="list-style-type: none"> • Pickup moves to the inner circumference *2 	<ul style="list-style-type: none"> • Sled circuit check • Mechanism operation check • Pickup Check
		RWD button	CD TEST	<ul style="list-style-type: none"> • Pickup is moves to the outer circumference *2 	

* 1. The driver IC heats up and the protection circuit starts working when the focus search is continued for 10 minutes or longer. There can be a case that operations cannot be performed correctly. In such a case, turn off the main power. After cooling down the machine, restart the machine.

* 2. Be careful not to damage the gear because the sled motor rotates while the FF or RWD button is being pressed even if the pickup is located in the innermost track or the outermost track.

MECHANICAL EXPLODED VIEW

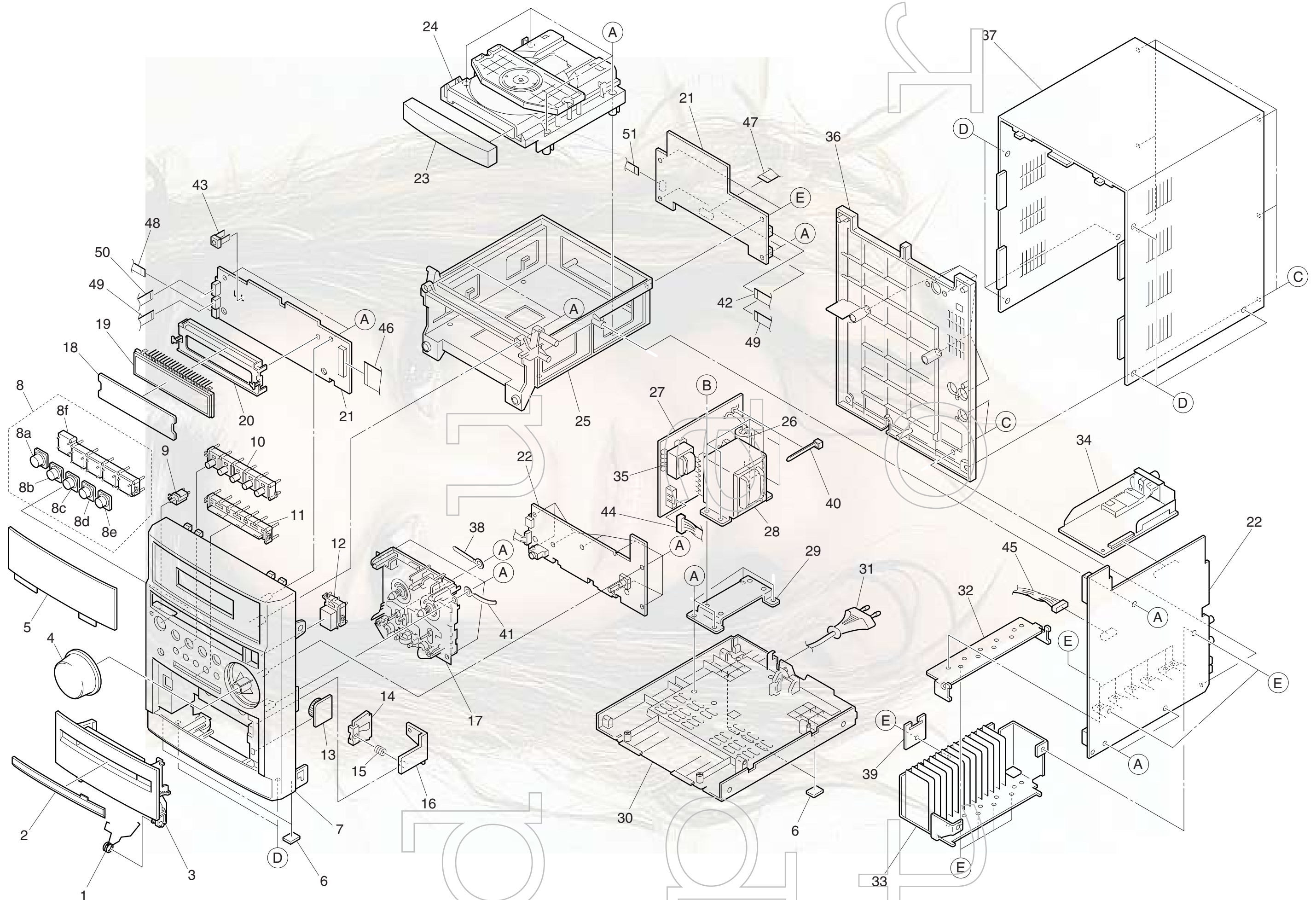

MECHANICAL PARTS LIST

! = Δ SAFETY PARTS
 C = Components marked

All components used on this model at the production line are shown in this service manual.
 However, please note that not all components will be available as spare parts for after-sales service.
 Components marked S and O are designated as spare parts for service and will be stocked at the spare parts centers.
 Components marked X and R are not designated as spare parts for after sales service, and will not be stocked at the spare parts centers.

UNIT-NAME	! C	REF-NO	PARTS-NO	PARTS-NAME	SUFFIX&MODEL
					CX-LEM52 EZSC
	0	MC1001	8C-CL5-205-010	SPR-T, CASS SUS304 DIA=1.0mm	a
	0	MC1002	8C-CL5-007-010	WINDOW,CASS AS J-SK805 SP-572	a
	0	MC1003	8C-CL5-004-110	BOX,CASS HIPS J-NL008 T-MS682	a
	0	MC1004	8C-CL5-009-010	KNOB,RTRY VOL ABS PLATINGMOO2	a
	0	MC1005	8C-CLS-003-010	WINDOW,FL 52RDS AS J-SK802 SP	a
	0	MC1006	8Z-CL8-204-010	RUBBER FOOT (PORON HH48C)T=2m	a
	0	MC1007	8C-CL5-026-010	CABI,FR RDS	a
	0	MC1008	8C-CL5-018-010	KEY,POWER ASSY	a
	X	MC1008a	8C-CL5-010-010	CAP,KEY-POWER ABS 94HB UL No.	a
	X	MC1008b	8C-CL5-011-010	CAP,KEY-TAPE (PLATING M-002)	a
	X	MC1008c	8C-CL5-012-010	CAP, KEY-TU ABS 94HB BASF GP2	a
	X	MC1008d	8C-CL5-013-010	CAP,KEY-AUX ABS 94HB BASF GP2	a
	X	MC1008e	8C-CL5-014-010	CAP,KEY-CD ABS 94HB BASF GP22	a
	0	MC1008f	8C-CL5-203-010	FRAME,KEY ABS BLACK	a
	0	MC1009	8C-CL5-008-010	LENS,OPE AS J-SK801	a
	0	MC1010	8C-CL5-015-010	KEY,OPE ABS J-NL008 T-MS682 S	a
	0	MC1011	8C-CL5-016-010	KEY,BASS/TRE ABS J-NL008 T-MS	a
	0	MC1012	8C-CL5-017-010	KEY,CD OPEN ABS BASF GP22 E41	a
	0	MC1013	86-NFZ-231-010	Damper 70 [DAMPER 70 86-NFZ-2	a
	0	MC1014	82-NF5-229-010	LEVER, CASS LOCKER	a
					CX-LEM52 EZSC
	0	MC1015	86-NF9-224-010	SPR-C. Lock	a
	0	MC1016	88-CL5-202-010	HLDR, LOCK (POM) 88-CC5-202-0	a
	X	MC1017	M8-CZK-291-070	CASS DECK,CMAL1Z23A (AUTO-RE	a
	X	MC1018	8C-CL5-027-010	SH,PC THK=0.3-0.5mm	a
	0	MC1019	8C-CL5-608-010	VACUUM PLUORESCENT DISPIAY 11	a
	0	MC1020	82-NF7-210-110	GUIDE, FL (ABS.BLACK)	a
	X	MC1021	8C-CL5-605-010	PWB CD & FR SIZE:197x163mm TH	a
	X	MC1022	8C-CL5-606-010	PWB MAIN & KEY SIZE:247x197mm	a
	0	MC1023	8C-CL5-005-010	PANEL,CD TRAY PS J-NL008 T-MS	a
	X	MC1024	M8-3ZG-380-070	CD MECHA 3ZG-3 E2NC	a
	0	MC1025	8C-CL5-202-110	HLDR, CD HIPS BLACK	a
	0	MC1026	87-A90-562-010	F-BEAD , 9.5-17.5-28.5 BRH	a
	X	MC1027	8C-CL5-607-010	PWB PT SIZE:247x191mm THK=1.6	a
	!	MC1028	8C-CL5-603-010	Power Transformer, 230V EI57	a
	0	MC1029	8A-CL9-211-110	HLDR, TRANS MAT'L SECC T=1.2m	a
	X	MC1030	8C-CL5-201-010	CHAS,MAIN HIPS 492J	a
	!	MC1031	87-A80-143-010	AC Power Cord ASSY,E.BLACK (2	a
	X	MC1032	8C-CL5-209-010	HT-SINK,\$UE A1050P T=2mm	a
	X	MC1033	8C-CL5-210-010	HT-SINK,MAIN ASSY	a
	X	MC1033a	8C-CL5-204-010	HT-SINK,MAIN	a
					CX-LEM52 EZSC
	X	MC1033b	8Z-CL8-210-010	HT-SINK,FIN	a
	X	MC1034	A8-CZA-390-070	CZA-3 EZC	a
	!	MC1035	8B-NF9-665-010	Power Transformer, 230V EI28	a
	0	MC1036	8C-CL5-002-010	PANEL,REAR EZ HIPS J-ND002	a
	0	MC1037	8C-CL5-003-010	CABI, TOP HIPS J-NL008 T-MS70	a
	0	MC1038	87-064-185-010	Mounting Lug (PG CW-2) (CX-NV	a
	X	MC1039	8C-CL5-208-010	HLDR,PWB CABLE	a
	X	MC1040	87-A90-230-010	"Nylon Tie 3"" (NYLON)	a
	X	MC1041	88-CL4-707-010	WIRE,ASSY 1P (DECK) L=35mm+5m	a
	0	MC1042	88-906-131-110	FF-CABLE,6P P=1.25 L=130mm +(a
	0	MC1043	8C-CL5-207-010	HLDR,SENSOR SPTE THK=0.3mm	a
	0	MC1044	8A-NF8-655-010	CONN ASSY 7P P=2.0mm L=240mm	a
	0	MC1045	88-CL4-701-010	CONN ASSY,7P RPEH	a
	0	MC1046	88-921-101-110	FF-CABLE 21P P=1.25 L=60mm+(4	a
	0	MC1047	88-CL4-704-010	FF-Cable 16PINS Pitch=1.0mm L	a
	0	MC1048	88-907-251-110	FF-CABLE. 7P P=1.25mm L=250mm	a
	0	MC1049	88-906-131-110	FF-CABLE 6P P=1.25mm L=110mm	a
	0	MC1050	S1-204-021-000	FF-CABLE 8P P=1.25 L=220mm+(4	a
	0	MC1051	88-905-231-110	FF-CABLE,5P P=1.25 L=230mm +(a
	0	MC1A	87-067-703-010	RH/TS 3 x L10mm (B-TYPE) (BRI	a
					CX-LEM52 EZSC
	0	MC1B	87-581-170-410	BH/ MS 4 x L8mm SCREW	a
	0	MC1C	87-B10-230-010	RH/TS 3xL10mm,PLATING:NICKEL	a
	0	MC1D	87-B10-118-010	KH/TS 3 x L12 mm (A133012003)	a
	0	MC1E	87-067-579-010	RH/TS 3xL8mm (B-TYPE) (AIWA :	a

COLOR NAME TABLE

Basic color symbol	Color	Basic color symbol	Color	Basic color symbol	Color
B	Black	C	Cream	D	Orange
G	Green	H	Gray	L	Blue
LT	Transparent Blue	N	Gold	P	Pink
R	Red	S	Silver	ST	Titan Silver
T	Brown	V	Violet	W	White
WT	Transparent White	Y	Yellow	YT	Transparent Yellow
LM	Metallic Blue	LL	Light Blue	GT	Transparent Green
LD	Dark Blue	DT	Transparent Orange	GM	Metallic Green
YM	Metallic Yellow	DM	Metallic Orange	PT	Transparent Pink
LA	Aqua Blue	GL	Light Green	HT	Transparent Gray
HM	Metallic Gray	NH	Champagne Gold	M	Wood Pattern

TAPE MECHANISM EXPLODED VIEW

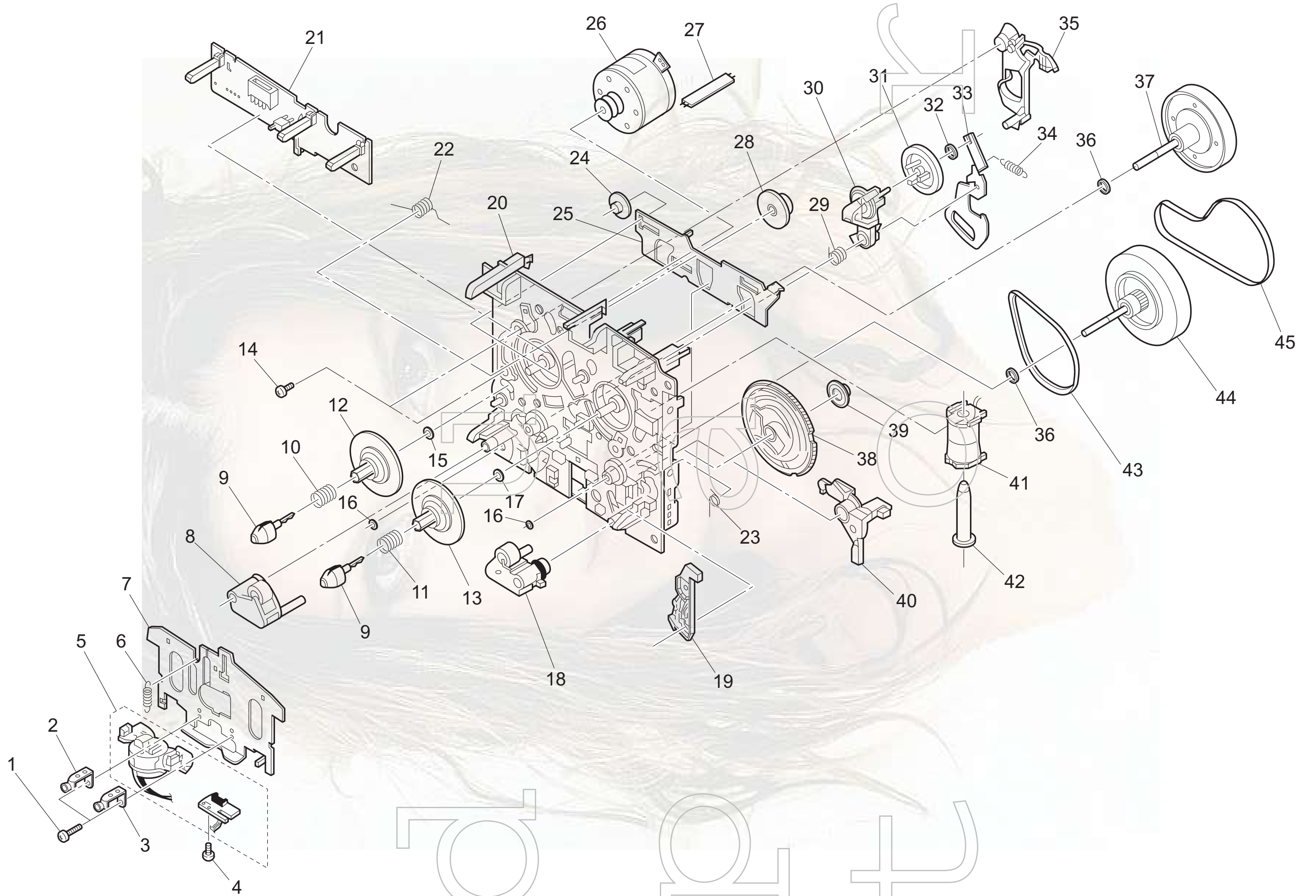

TAPE MECHANISM PARTS LIST

! =  SAFETY PARTS
 C = Components marked

All components used on this model at the production line are shown in this service manual.
 However, please note that not all components will be available as spare parts for after-sales service.
 Components marked S and O are designated as spare parts for service and will be stocked at the spare parts centers.
 Components marked X and R are not designated as spare parts for after sales service, and will not be stocked at the spare parts centers.

UNIT-NAME	! C	REF-NO	PARTS-NO	PARTS-NAME	SUFFIX&MODEL
					CMAL1Z223A
	O	ST1001	SK-G19-436-000	SCREW, PAN TT 2.0X6 ZN	a
	O	ST1002	SF-512-127-000	PLATE BASE BLK	a
	O	ST1003	SF-512-128-000	PLATE BASE BLK	a
	O	ST1004	SK-G19-434-000	SCREW, PAN TT 2.0X4 ZN	a
	O	ST1005	SF-513-890-000	PLATE HD BLK	a
	O	ST1006	SF-K32-T32-000	SPRING HB	a
	O	ST1007	SF-C61-K35-000	HEAD BASE	a
	O	ST1008	SF-514-134-000	ROLLER PINCH L BLK	a
	O	ST1009	SF-D53-M51-000	REEL FEATHER	a
	O	ST1010	SF-K32-U12-000	SP REEL (L)	a
	O	ST1011	SF-K32-V12-000	SP REEL (R)	a
	O	ST1012	SF-D52-W61-000	REEL BASE	a
	O	ST1013	SF-D52-W51-000	REEL BASE	a
	O	ST1014	SF-G11-414-000	SCREW, PAN SW 2.6X5 ZN	a
	O	ST1015	SF-J11-131-000	PW, 4.1X0.13	a
	O	ST1016	SU-J16-F11-000	PW, 1.75X0.4	a
	O	ST1017	SF-J11-135-000	PW, 4.1X0.25	a
	O	ST1018	SF-514-133-000	ROLLER PINCH R BLK	a
	O	ST1019	SF-D58-K13-000	ARM INTERLOCK R	a
	O	ST1020	SF-612-234-000	CHASSIS BASE BLK	a
					CMAL1Z223A
	O	ST1021	SF-567-689-000	PWB CONTROL BLK	a
	O	ST1022	SF-K34-Y11-000	B/C SP	a
	O	ST1023	SF-K35-F12-000	SP ARM PLAY	a
	O	ST1024	SF-D53-K52-000	PLAY GEAR (A)	a
	O	ST1025	SF-C61-L20-000	PLATE SLIDE	a
	O	ST1026	SF-525-348-000	MTR MAIN BLK	a
	X	ST1027	SW-G58-H02-000	2 CORE JUMPER LEAD	a
	O	ST1028	SF-D60-L12-000	FF GEAR (E)	a
	O	ST1029	SF-K35-K14-000	CAM SP	a
	O	ST1030	SF-522-063-000	CLUTCH ASSY BLK	a
	O	ST1031	SF-D60-B15-000	PULLEY F/R	a
	O	ST1032	SF-J11-117-000	WASHER 1.7X0.25	a
	O	ST1033	SF-C65-W21-000	LEVER F/R	a
	O	ST1034	SF-K35-E14-000	SP ARM F/R	a
	O	ST1035	SF-D58-T12-000	LEVER BRAKE	a
	O	ST1036	SF-J11-130-000	PW, 2.6X0.25	a
	O	ST1037	SF-R25-M11-000	ASSY F/W	a
	O	ST1038	SF-D61-C14-000	CAM GEAR	a
	O	ST1039	SF-D59-F12-000	BUSH	a
	O	ST1040	SF-D58-P15-000	ARM PLAY	a
					CMAL1Z223A
	O	ST1041	SF-765-295-000	SOLENOID BLK	a
	O	ST1042	SF-L41-S22-000	PLANGER	a
	O	ST1043	SF-F19-S31-000	F/R BELT	a
	O	ST1044	SF-R26-D11-000	ASSY F/W	a
	O	ST1045	SF-F19-U31-000	MAIN BELT	a

CD MECHANISM EXPLODED VIEW 1 / 2 <3ZG - 3>

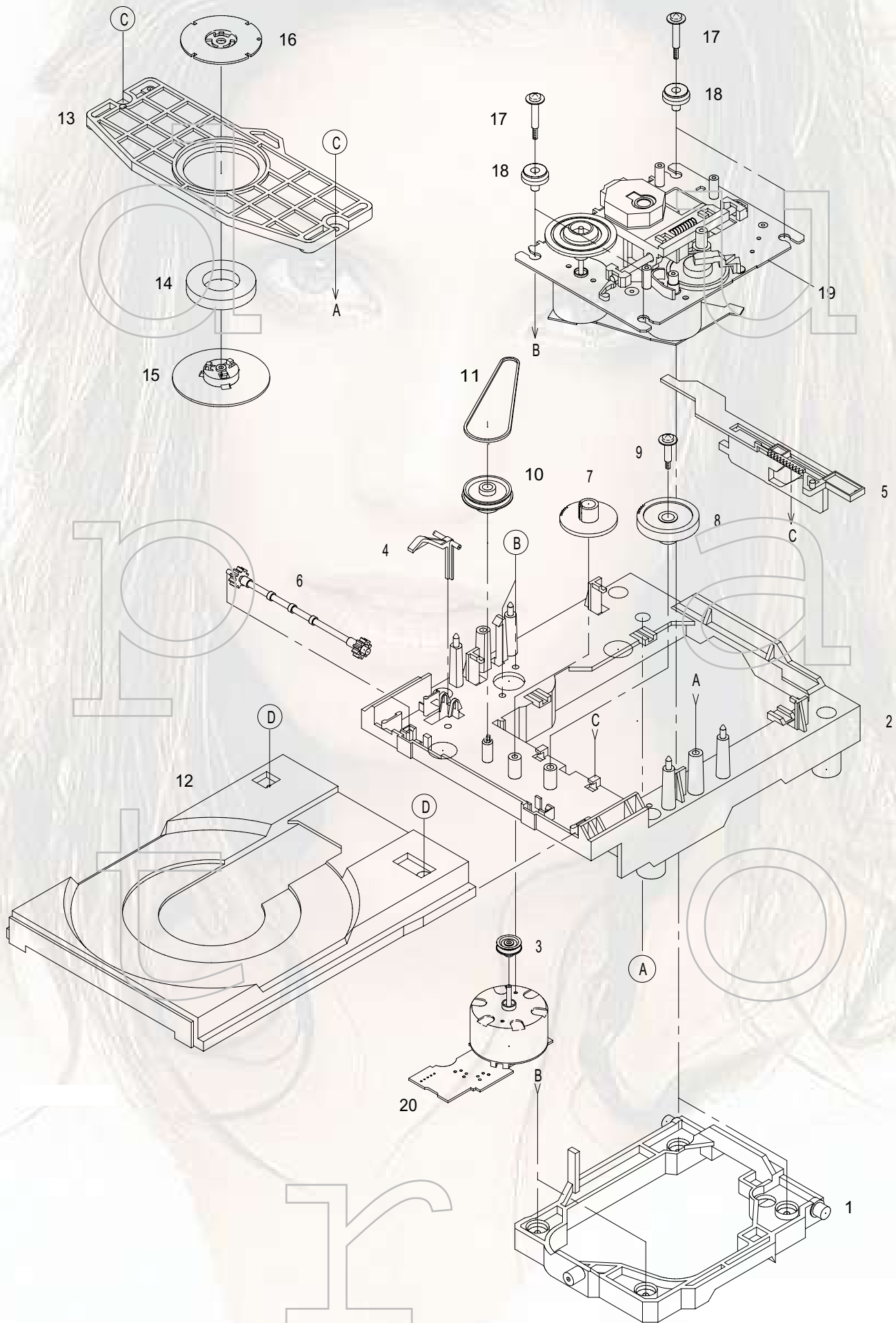

CD MECHANISM PARTS LIST 1 / 2 (3ZG - 3)

! =  SAFETY PARTS
 C = Components marked

All components used on this model at the production line are shown in this service manual.
 However, please note that not all components will be available as spare parts for after-sales service.
 Components marked S and O are designated as spare parts for service and will be stocked at the spare parts centers.
 Components marked X and R are not designated as spare parts for after sales service, and will not be stocked at the spare parts centers.

UNIT-NAME	! C	REF-NO	PARTS-NO	PARTS-NAME	SUFFIX&MODEL
					3ZG-3 E2NC
	O	SC1001	83-ZG3-224-510	HLDR M2	a
	O	SC1002	83-ZG3-228-710	CHAS, L6	a
	O	SC1003	83-ZG3-208-010	PULLEY, MOTOR	a
	O	SC1004	83-ZG3-213-010	LVR, SW	a
	O	SC1005	83-ZG3-209-810	CAM, SLIDE	a
	O	SC1006	83-ZG3-207-010	GEAR, TRAY	a
	O	SC1007	83-ZG3-204-210	GEAR, C	a
	O	SC1008	83-ZG3-205-010	GEAR, D	a
	O	SC1009	83-ZG3-217-010	S-SCREW, GEAR D	a
	O	SC1010	83-ZG3-220-210	GEAR, PULLEY 2	a
	O	SC1011	83-ZG3-214-010	BELT, L	a
	O	SC1012	83-ZG3-229-510	TRAY, CD 2	a
	O	SC1013	83-ZG3-236-010	HLDR, CHUCK 3	a
	O	SC1014	83-ZG3-604-010	RING, MAG 2	a
	O	SC1015	83-ZG3-212-010	CAP, DISC	a
	O	SC1016	83-ZG3-211-010	PLATE, DISC	a
	O	SC1017	81-ZG1-254-010	S-SCREW, MECH HLDR	a
	O	SC1018	83-ZG3-225-010	CUSH-G, MAIN A	a
	X	SC1019	M8-3ZG-261-070	3ZG-2 E3NC	a
	X	SC1020	83-ZG3-603-010	PWB, LOAD-A 27M	a
					3ZG-3 E2NC
	O	SC1A	87-067-945-110	VFT2+3-12 (F10)	a
	O	SC1B	87-251-071-410	U+2.6-4	a
	O	SC1C	83-ZG3-235-010	VFT2+2.6-8	a
	O	SC1D	87-352-075-210	VT2+2.6-10	a

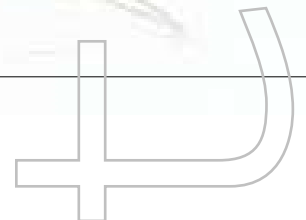
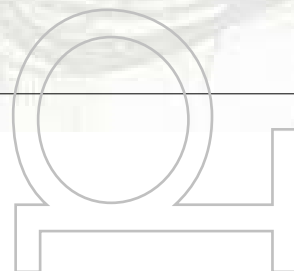
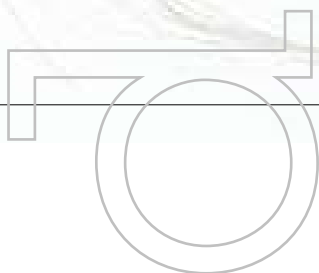
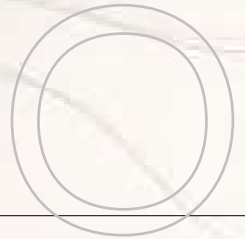
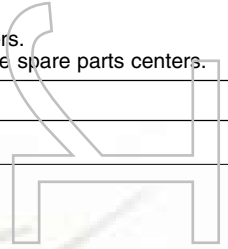

CD MECHANISM EXPLODED VIEW 2 / 2 <3ZG - 2>

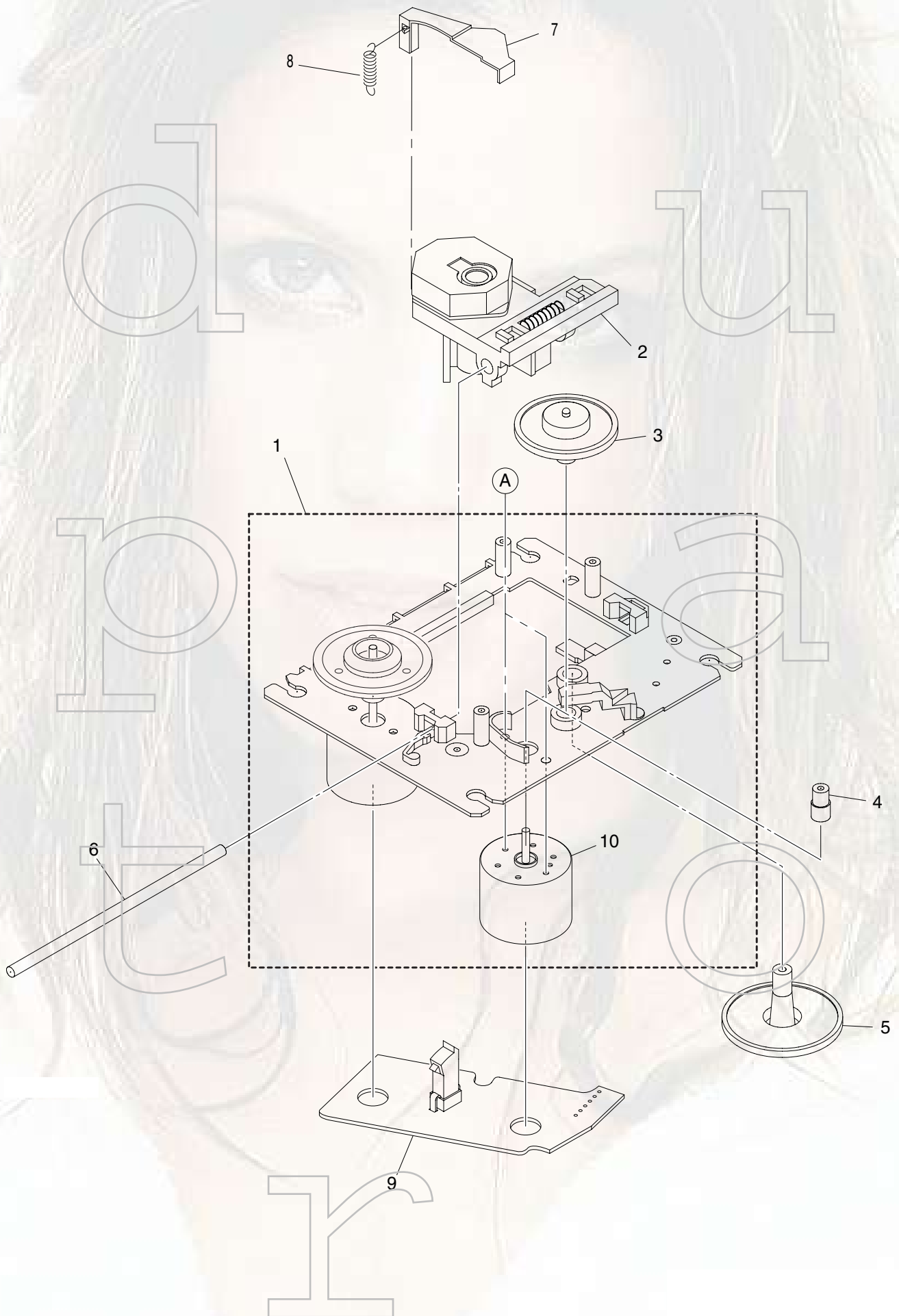

CD MECHANISM PARTS LIST 2 / 2 (3ZG - 2)

! =  SAFETY PARTS
 C = Components marked

All components used on this model at the production line are shown in this service manual.
 However, please note that not all components will be available as spare parts for after-sales service.
 Components marked S and O are designated as spare parts for service and will be stocked at the spare parts centers.
 Components marked X and R are not designated as spare parts for after sales service, and will not be stocked at the spare parts centers.

UNIT-NAME	! C	REF-NO	PARTS-NO	PARTS-NAME	SUFFIX&MODEL
					3ZG-2 E3NC
	O	SC2001	83-ZG2-243-410	CHAS ASSY, SHT	a
	X	SC2001a	83-ZG2-244-310	CHAS, SHT	a
	O	SC2001b	83-ZG2-249-110	TURN TABLE, C3	a
	O	SC2001c	83-ZG2-241-210	PLATE, C2	a
	O	SC2002	87-A90-836-010	PICKUP, KSS-213F	a
	O	SC2003	83-ZG2-235-010	GEAR, A3	a
	O	SC2004	83-ZG2-236-010	GEAR, MOTOR 3	a
	O	SC2005	83-ZG2-205-210	GEAR, B	a
	O	SC2006	83-ZG2-253-110	SHAFT, SLIDE 5	a
	O	SC2007	83-ZG2-245-510	LEVER, SHUTTER	a
	O	SC2008	83-ZG2-250-210	SPR-E, SHT 2	a
	X	SC2009	83-ZG2-609-010	PWB, DRIVE-G 21M	a
	O	SC2010	87-045-358-010	MOT, RF-310TA 43	a
	O	SC2A	87-261-032-210	V+2-3	a

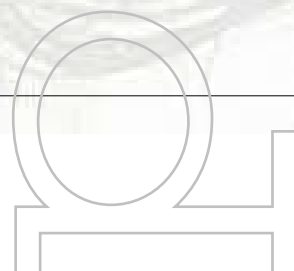
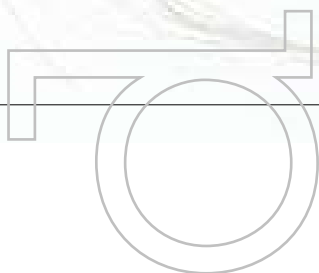
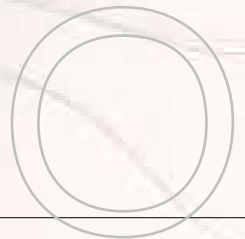
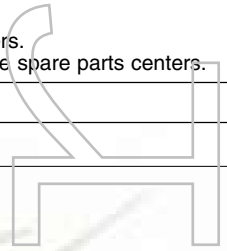

GENERAL SPEAKER DISASSEMBLY INSTRUCTIONS (FOR REFERENCE)

Type.1

Insert a flat-bladed screwdriver into the position indicated by the arrows and remove the panel. Remove the screws of each speaker unit and then remove the speaker units.

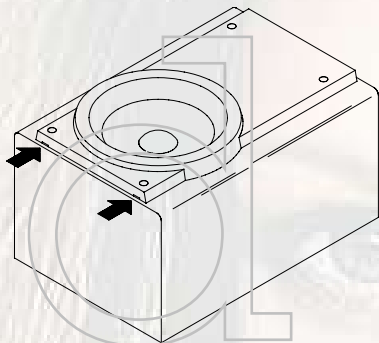

Type.2

Remove the grill frame and four pieces of rubber caps by pulling out with a flat-bladed screwdriver. Remove the screws from hole where installed rubber caps. Insert a flat-bladed screwdriver into the position indicated by the arrows and remove the panel. Remove the screws of each speaker unit and then remove the speaker units.

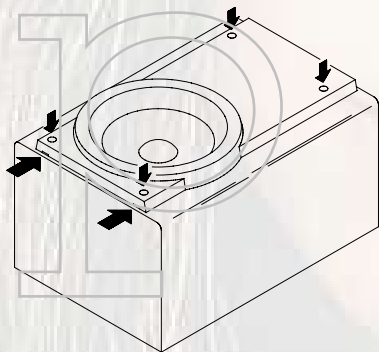

Type.3

Insert a flat-bladed screwdriver into the position indicated by the arrows and remove the panel. Turn the speaker unit to counter-clockwise direction while inserting a flat-bladed screwdriver into one of the hollows around speaker unit, and then remove the speaker unit. After replacing the speaker unit, install it turning to clockwise direction until "click" sound comes out.

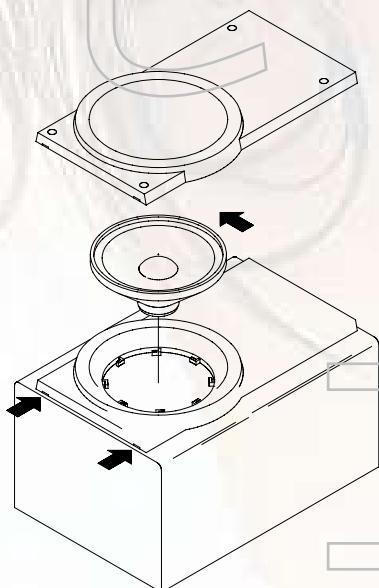

Type.4

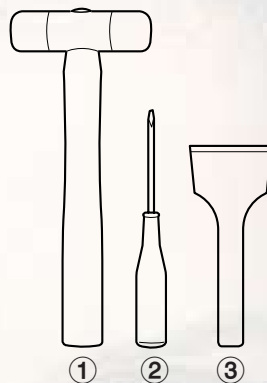

TOOLS

- ① Plastic head hammer
- ② (⊖) flat head screwdriver
- ③ Cut chisel

How to Remove the PANEL, FR

1. Insert the (⊖) flat head screwdriver tip into the gap between the PANEL, FR and the PANEL, SPKR. Tap the head of the (⊖) flat head screwdriver with the plastic hammer head, and create the clearance as shown in Fig-1.
2. Insert the cut chisel in the clearance, and tap the head of the cut chisel with plastic hammer as shown in Fig-2, to remove the PANEL, FR.
3. Place the speaker horizontally. Tap head of the cut chisel with plastic hammer as shown in Fig-3, and remove the PANEL, FR completely.

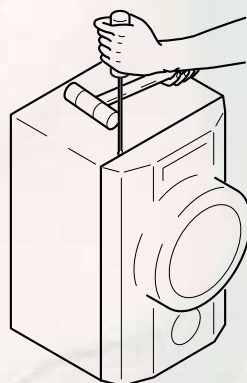

Fig-1

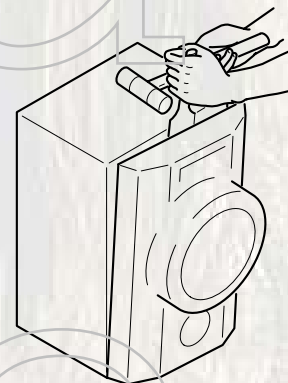

Fig-2

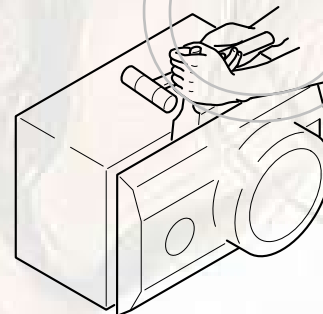

Fig-3

How to Attach the PANEL, FR

Attach the PANEL, FR to the PANEL, SPKR. Tap the four corners of the PANEL, FR with the plastic hammer to fit the PANEL, FR into the PANEL, SPKR completely.

SPEAKER PARTS LIST (SX – LEM52)

! =  SAFETY PARTS
 C = Components marked

All components used on this model at the production line are shown in this service manual.
 However, please note that not all components will be available as spare parts for after-sales service.
 Components marked S and O are designated as spare parts for service and will be stocked at the spare parts centers.
 Components marked X and R are not designated as spare parts for after sales service, and will not be stocked at the spare parts centers.

UNIT-NAME	! C	REF-NO	PARTS-NO	PARTS-NAME	SUFFIX&MODEL
					SX-LEM52 YJMN
	X	001	8B-CPX-016-010	BADGE, ATWA 27.5	a
	X	002	8C-CP5-005-010	TUBE,	a
	O	003	8C-CP5-007-010	CORD, SPKR O	a
	O	004	8C-CP5-008-010	CORD, BUSH O	a
	X	005	8C-CPS-001-010	LBL, SPEC YJ	a
	O	006	8C-CPS-002-010	RING, SP	a
	O	007	8C-CPS-003-010	CABI, M	a
	O	008	8C-CPS-004-010	GRILLE, FRAME ASSY	a
	X	009	8C-CPS-005-010	GRILLE, FRAME	a
	X	010	8C-CPS-006-010	NET,	a
	O	011	8C-CPS-602-010	SPKR, W 120 25/2	a
	O	012	8C-CPS-604-010	SPKR, T	a
	X	013	PC-CPS-917-070	SX-SLEM52 YJMN	a

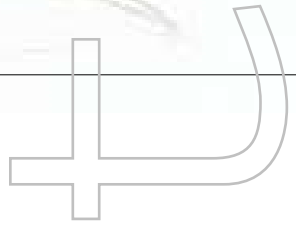
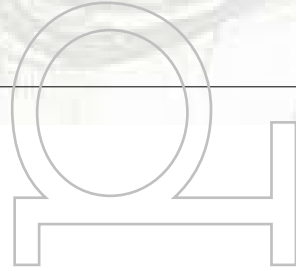
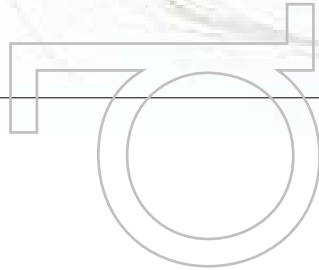
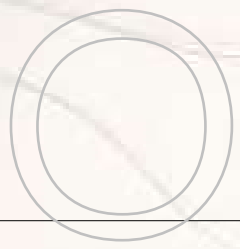
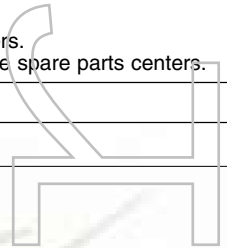

ACCESSORIES PARTS LIST (CX – LEM52)

- ! =  SAFETY PARTS
- C = Components marked

All components used on this model at the production line are shown in this service manual.
 However, please note that not all components will be available as spare parts for after-sales service.
 Components marked S and O are designated as spare parts for service and will be stocked at the spare parts centers.
 Components marked X and R are not designated as spare parts for after sales service, and will not be stocked at the spare parts centers.

UNIT-NAME	! C	REF-NO	PARTS-NO	PARTS-NAME	SUFFIX&MODEL
					CX-LEM52 EZSC
	O	1	87-A92-346-010	ANT, WIRE FM EZ/K L=1500	a
	O	2	87-A90-054-010	Ant. Loop AM-CON C TOMEI NO:	a
	O	3	8C-CL5-906-010	IB, EZ (9L) B SIZE: 210x148mm M:7	a
	O	4	8C-CL5-701-010	Remote Control Unit RC-CAS06	a

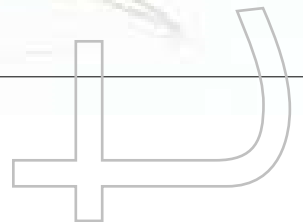
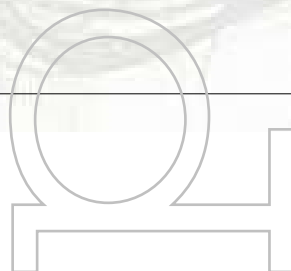
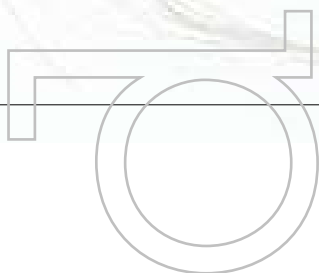
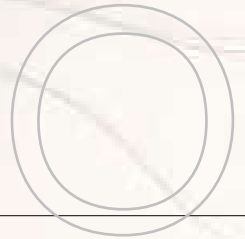
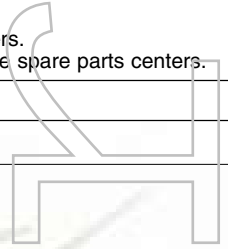

OTHER PARTS LIST (CX – LEM52)

- ! =  SAFETY PARTS
- C = Components marked

All components used on this model at the production line are shown in this service manual.
 However, please note that not all components will be available as spare parts for after-sales service.
 Components marked S and O are designated as spare parts for service and will be stocked at the spare parts centers.
 Components marked X and R are not designated as spare parts for after sales service, and will not be stocked at the spare parts centers.

UNIT-NAME	! C	REF-NO	PARTS-NO	PARTS-NAME	SUFFIX&MODEL
					CX-LEM52 EZSC
	X		8C-CL5-851-010	CUSHION FRONT EPS	a
	X		8C-CL5-852-010	CUSHION REAR EPS	a
	X		87-056-168-010	Europe Warranty Information C	a
	X		87-B40-281-010	Label Bar Code A {Using ART R	a
	X		87-057-961-010	LBL,CAUTION TRIANGLE 2 SIZE:(a
	X		87-B50-079-010	LIST,FACILITY (B)-0007 M:70W/	a
	X		S4-700-172-000	Polybag 19" x 24" x 0.05 (Rec	a
	X		87-B40-057-010	Polybag 7" x 7" x 0.05 (RECYC	a
	X		87-B40-085-010	Polybag 8 1/2" x 13 1/2" x 0.	a
	X		87-B40-295-010	SH,FOAMED MAT 0.5-250-400 Siz	a
	X		8C-CL5-970-010	LBL,POP K SIZE:(44.5x31)mm 3C	a
	X		8C-FL5-857-010	CTN,PRINTED 57EZSC SIZE:(564x	a
	X		8C-CL5-052-010	LBL,SPEC 57EZ C:1.9mm SIZE:(a

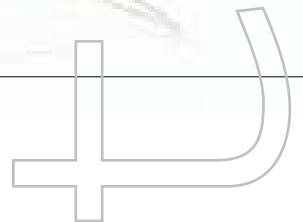
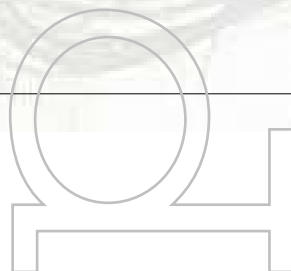
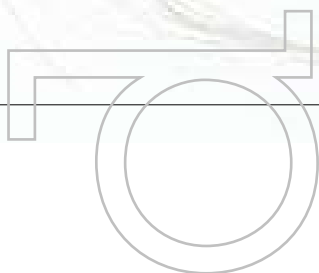
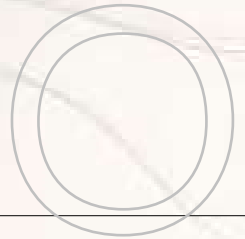
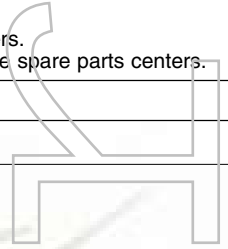

OTHER PARTS LIST (CZA – 3)

- ! =  SAFETY PARTS
- C = Components marked

All components used on this model at the production line are shown in this service manual.
 However, please note that not all components will be available as spare parts for after-sales service.
 Components marked S and O are designated as spare parts for service and will be stocked at the spare parts centers.
 Components marked X and R are not designated as spare parts for after sales service, and will not be stocked at the spare parts centers.

UNIT-NAME	! C REF-NO	PARTS-NO	PARTS-NAME	SUFFIX&MODEL
ASSY CODE	X	A8-CZA-390-070	CZA-3 EZC	CZA-3 EZC a

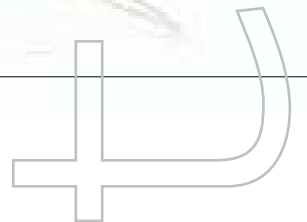
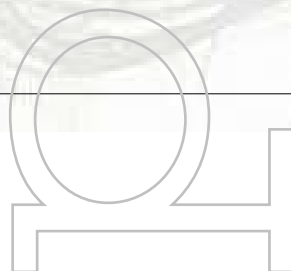
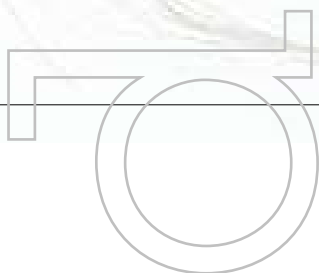
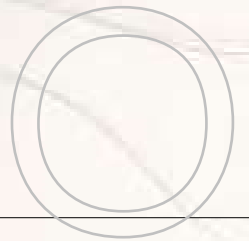
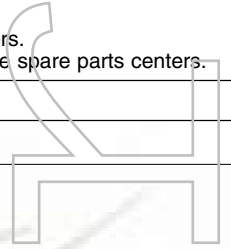

OTHER PARTS LIST (3ZG – 3)

- ! =  SAFETY PARTS
- C = Components marked

All components used on this model at the production line are shown in this service manual.
 However, please note that not all components will be available as spare parts for after-sales service.
 Components marked S and O are designated as spare parts for service and will be stocked at the spare parts centers.
 Components marked X and R are not designated as spare parts for after sales service, and will not be stocked at the spare parts centers.

UNIT-NAME	! C	REF-NO	PARTS-NO	PARTS-NAME	SUFFIX&MODEL
					3ZG-3 E2NC
PACKING	X		83-ZG3-599-010	BAG, PV ANTI 390X265	a
PACKING	X		83-ZG3-857-010	CTN, PRINTED E1NC	a
PACKING	X		83-ZG3-858-010	CUSHION, BOTTOM NC	a
PACKING	X		83-ZG3-859-010	CUSHION, TOP NC	a
	X		81-MX4-700-010	SHIELD CORE, MOT S	a

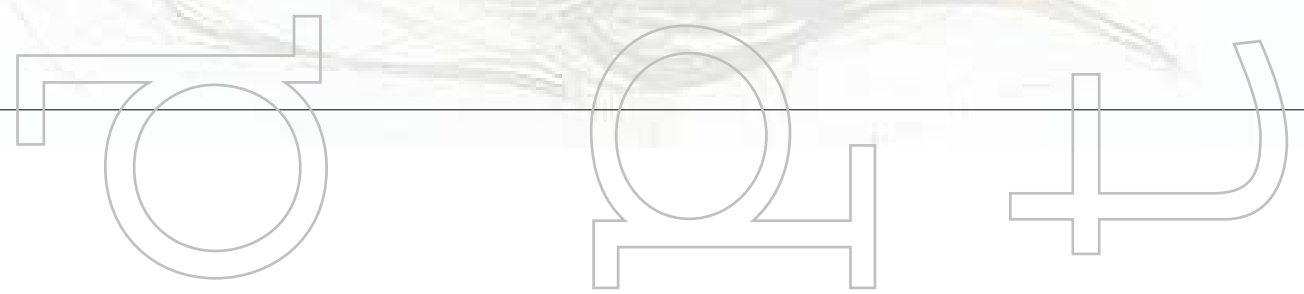
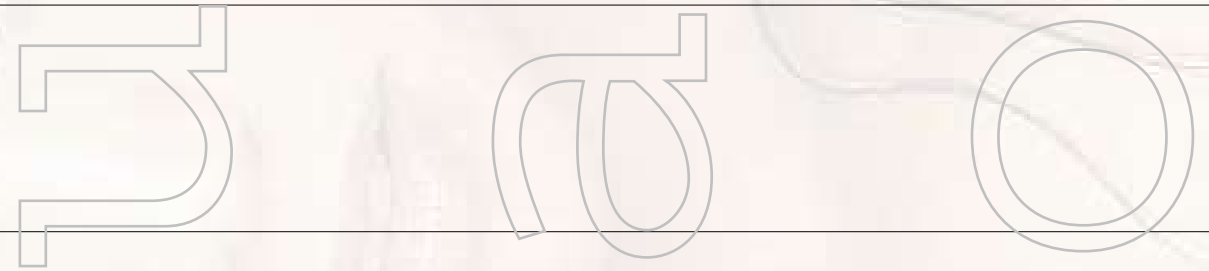
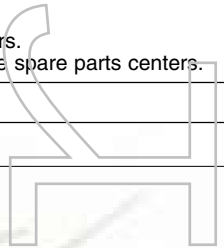



アイワ株式会社 〒110-8710 東京都台東区池之端1-2-11 ☎03(3827)3111 (代表)
AIWA CO.,LTD. 2-11, IKENOHATA 1-CHOME, TAITO-KU, TOKYO 110-8710, JAPAN TEL:03 (3827) 3111

9301944 9430209 921338