

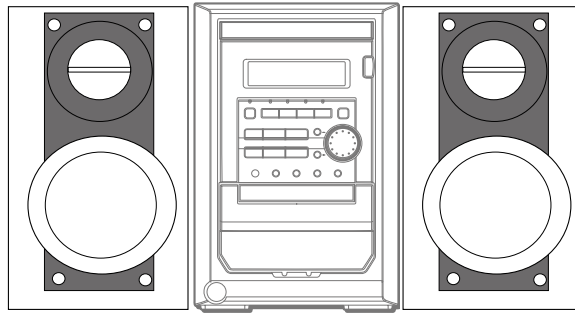

**XR-M100**  
**XR-M120**  
**XR-M121**  
**XR-M130**  
**XR-M150**  
**XR-M151**  
**XR-M152**

EZ  
 K  
 EZ  
 HR,HT  
 K  
 EZ  
 EZ



# SERVICE MANUAL

COMPACT DISC  
 STEREO SYSTEM

BASIC TAPE MECHANISM: 2ZM-1 R8NF  
 BASIC CD MECHANISM: 3ZG-3 E2NF

SYSTEM	REMOTE CONTROLLER
XR-M100	RC-AAT11
XR-M120	
XR-M121	
XR-M130	
XR-M150	
XR-M151	
XR-M152	

- This Service Manual is the "Revision Publishing" and replace the "Simple Manual" XR-M100/120/121 <EZ,K> (S/M Code No. 09-004-432-5T1), XR-M130/150/151/152 <EZ,HR,K> (S/M Code No. 09-005-426-2T2) and XR-M130<HT> (S/M Code No. 09-006-426-2T3).

**aiwa**  
 S/M Code No. 09-007-426-2R2

REVISION  
 DATA

# SPECIFICATIONS

## <FM Tuner section>

<b>Tuning range</b>	87.5 MHz to 108 MHz
<b>Usable sensitivity(IHF)</b>	16.8 dBf<EZ,K>, 13.2 dBf<HR,HT>
<b>Antenna terminals</b>	75 ohms (unbalanced)

## <AM Tuner section>

<b>Tuning range</b>	531 kHz to 1602 kHz (9 kHz step) 530 kHz to 1710 kHz (10 kHz step)
<b>Usable sensitivity</b>	350 uV/m
<b>Antenna</b>	Loop antenna

## <LM Tuner section>(EZ,K)

<b>Tuning range</b>	144 kHz to 290 kHz
<b>Usable sensitivity</b>	1400 uV/m
<b>Antenna</b>	Loop antenna

## <Amplifier section>

### Power output<100EZ,120K,121EZ>

Rated: 8 W +8 W
(16 ohms, T.H.D. 1%, 1 kHz/DIN 45500)
Reference: 10 W + 10 W
(16 ohms, T.H.D. 10 %, 1 kHz/DIN 45324)

### Power output<130HR,HT,150K,151,152EZ>

Rated: 12 W + 12 W
(8 ohms, T.H.D. 1%, 1 kHz/DIN45500)
Reference: 15 W + 15 W
(8 ohms, T.H.D. 10 %, 1 kHz/DIN45324)

### Total harmonic distortion

0.07 % (7.5 W, 1 kHz, 16 ohms, DIN AUDIO)<100EZ,120K,121EZ>
0.07 % (7.5 W, 1 kHz, 8 ohms, DIN AUDIO)<130HR,HT,150K,151,152EZ>
DIN MUSIC POWER: 16 W + 16 W<100EZ,120K,121EZ>
27.5 W + 27.5 W<150K,151,152EZ>

## Inputs

### Outputs

VIDEO/AUX: 0.4 V
SUB WOOFER: 1.0 V
SPEAKERS: accept speakers of 16 ohms or more<100EZ,120K,121EZ>
accept speakers of 8 ohms or more<130HR,HT,150K,151,152EZ>
PHONES (stereo minijack) : accepts headphones of 32 ohms or more

## <Cassette deck section>

<b>Track format</b>	4 tracks, 2 channels stereo
<b>Frequency response</b>	Normal tape: 50 Hz – 15000 Hz
<b>Signal-to-noise ratio</b>	50 dB
<b>Recording system</b>	AC bias
<b>Heads</b>	Recording/Playback head x 1 Erase head x 1

## <Compact disc player section>

<b>Laser</b>	Semiconductor laser ( $\lambda = 780 \text{ nm}$ )
<b>D-A converter</b>	1 bit dual
<b>Signal-to-noise ratio</b>	75 dB (1 kHz, 0 dB)
<b>Harmonic distortion</b>	0.1 % (1 kHz, 0 dB)
<b>Wow and flutter</b>	Unmeasurable

## <Speaker system>

<b>Cabinet type</b>	2 way, bass reflex
<b>Speaker</b>	Woofer: 120 mm (4 <sup>3</sup> / <sub>4</sub> in) cone type Tweeter: 20 mm ( <sup>13</sup> / <sub>16</sub> in) ceramic type
<b>Impedance</b>	16 ohms<100EZ,120K,121EZ> 8 ohms<130HR,HT,150K,151,152EZ>

## Output sound pressure level

### Dimensions (W x H x D)

87 dB/W/m
150 x 256 x 205 mm (6 x 10 <sup>1</sup> / <sub>8</sub> x 8 <sup>1</sup> / <sub>8</sub> in.)<100EZ>
150 x 256 x 210 mm (6 x 10 <sup>1</sup> / <sub>8</sub> x 8 <sup>3</sup> / <sub>8</sub> in.)<EXCEPT 100EZ>
1.2 kg (2 lbs 10 oz)<100EZ>
2.0 kg (4 lbs 7 oz)<EXCEPT 100EZ>

## Weight

## <General>

### Power requirements

AC: 230 V, 50 Hz<EZ,K>
AC: 120 V/ 220 V -240 V, Switchable 50/60 Hz<HR,HT>

### Power consumption

42 W<100EZ,120K,121EZ>, 50 W<150K>
45 W<130HR,HT,151,152EZ>, 168 x 256 x 255 mm

### Dimensions (W x H x D)

(6 <sup>5</sup> / <sub>8</sub> x 10 <sup>1</sup> / <sub>8</sub> x 10 <sup>1</sup> / <sub>8</sub> in)
3.5 kg (7 lbs 11 oz.)

### Weight of main unit

### Standby power consumption

If the power-economizing mode is on: 1.0 W
If the power-economizing mode is off: 10 W

- Design and specifications are subject to change without notice.

## ACCESSORIES / PACKAGE LIST

REF. NO.	PART NO.	KANRI NO.	DESCRIPTION
1	8A-CLK-913-010		IB,EZ (9L) M100 -IN<100EZ>
1	8A-CLK-912-010		IB,EZ (9L) -IN<121EZ>
1	8A-CLK-911-010		IB,K (E) -IN<120K>
1	8A-CL9-908-010		IB,H (ECA) -IN<130HR,HT>
1	8A-CL9-910-010		IB,K (E) -IN<150K>
1	8A-CL9-911-010		IB,E (9L) -IN<151,152EZ>
2	87-043-115-010		ANT,FEEDER FM<130HR,HT>
3	87-A90-030-010		ANT,LOOP AM-NC C
4	87-A91-017-010		PLUG,CONVERSION JT-0476<130HR,HT>
5	8A-CLB-961-010		RC UNIT,RC-AAT11
6	87-A90-118-010		ANT,WIRE FM(Z) <EXCEPT 130HR,HT>

# PROTECTION OF EYES FROM LASER BEAM DURING SERVICING

This set employs laser. Therefore, be sure to follow carefully the instructions below when servicing.

## WARNING!!

WHEN SERVICING, DO NOT APPROACH THE LASER EXIT WITH THE EYE TOO CLOSELY. IN CASE IT IS NECESSARY TO CONFIRM LASER BEAM EMISSION. BE SURE TO OBSERVE FROM A DISTANCE OF MORE THAN 30cm FROM THE SURFACE OF THE OBJECTIVE LENS ON THE OPTICAL PICK-UP BLOCK.

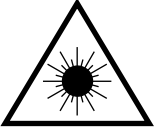

- Caution: Invisible laser radiation when open and interlocks defeated avoid exposure to beam.
- Advarsel: Usynlig laserstråling ved åbning, når sikkerhedsafbrydere er ude af funktion. Undgå udsættelse for stråling.

## VAROITUS!

Laitteen Käyttäminen muulla kuin tässä käyttöohjeessa mainitulla tavalla saattaa altistaa käyttäjän turvallisuusluokan 1 ylittävälle näkymättömälle lasersäteilylle.

## WARNING!

Om apparaten används på annat sätt än vad som specificeras i denna bruksanvisning, kan användaren utsättas för osynlig laserstrålning, som överskrider gränsen för laserklass 1.

## CAUTION

Use of controls or adjustments or performance of procedures other than those specified herein may result in hazardous radiation exposure.

## ATTENTION

L'utilisation de commandes, réglages ou procédures autres que ceux spécifiés peut entraîner une dangereuse exposition aux radiations.

## ADVARSEL

Usynlig laserstråling ved åbning, når sikkerhedsafbrydere er ude af funktion. Undgå udsættelse for stråling.

This Compact Disc player is classified as a CLASS 1 LASER product.

The CLASS 1 LASER PRODUCT label is located on the rear exterior.

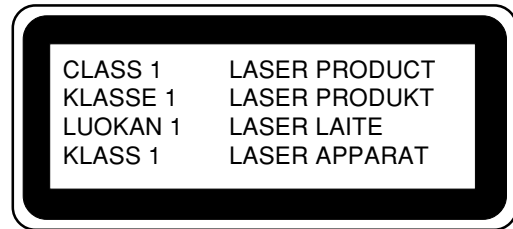

## Precaution to replace Optical block

### (KSS-213F)

Body or clothes electrostatic potential could ruin laser diode in the optical block. Be sure ground body and workbench, and use care the clothes do not touch the diode.

- 1) After the connection, remove solder shown in right figure.

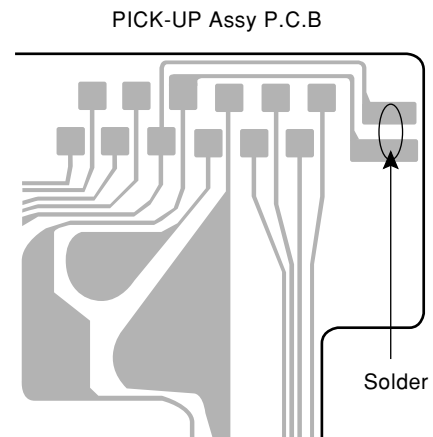

# ELECTRICAL MAIN PARTS LIST

REF. NO.	PART NO.	KANRI NO.	DESCRIPTION	REF. NO.	PART NO.	KANRI NO.	DESCRIPTION
<b>IC</b>				C107	87-010-384-080		CAP,E 100-25 M 11L SME
	87-070-127-110		IC,LC72131D	C108	87-010-381-080		CAP,E 330-16 M SME
	87-A20-913-010		IC,LA1837NL	C109	87-010-260-080		CAP,E 47-25 M 11L SME
	87-A20-446-010		C-IC,LA9241ML	C110	87-010-260-080		CAP,E 47-25 M 11L SME
	87-A20-459-010		C-IC,LC78622ED	C111	87-010-247-080		CAP,E 100-50 M SME
	87-A20-157-010		IC,TA2092N	C112	87-010-263-080		CAP,E 100-10 M 11L SME
	87-001-536-010		IC,NJM78M05FA	C113	87-010-403-080		CAP,E 3.3-50 M 11L SME
	87-001-982-010		IC,TA7291S	C114	87-010-374-080		CAP,E 47-10 M 11L SME
	8A-CL9-681-010		C-IC,M38B57MCH-P239FP	C115	87-A11-007-080		CAP,M 0.047-50 J DE
	87-017-889-010		IC,NJM4558LD	C116	87-A11-007-080		CAP,M 0.047-50 J DE
	87-A20-914-010		IC,SPS-442-1-F	C122	87-010-260-080		CAP,E 47-25 M 11L SME
	87-A21-520-040		C-IC,M61509FP	C123	87-010-260-080		CAP,E 47-25 M 11L SME
	87-020-454-010		IC,DN6851	C131	87-012-368-080		C-CAP,S 0.1-50 Z F
	87-A20-440-040		C-IC,BU1920FS<121,151,152EZ>	C132	87-012-368-080		C-CAP,S 0.1-50 Z F
				C151	87-010-196-080		C-CAP,S 0.1-25 Z F C2012
<b>TRANSISTOR</b>				C200	87-010-197-080		C-CAP,S 0.01-25 K B C2012
	87-A30-072-080		RT1P144C	C201	87-010-197-080		C-CAP,S 0.01-25 K B C2012
	89-327-143-080		2SC2714	C207	87-010-546-080		CAP,E 0.33-50 M 11L SME
	87-026-463-080		TR,2SA933SRS	C208	87-010-546-080		CAP,E 0.33-50 M 11L SME
	87-026-297-080		C-TR,DTA144TK	C209	87-010-186-080		C-CAP,S 4700P-50 K B C2012
	87-026-239-080		C-TR,DTC114TK	C210	87-010-186-080		C-CAP,S 4700P-50 K B C2012
	89-109-521-080		TR,2SA952K	C211	87-010-403-080		CAP,E 3.3-50 M 11L SME
	89-318-155-080		TR,2SC1815GR	C212	87-010-403-080		CAP,E 3.3-50 M 11L SME
	89-213-702-010		TR,2SB1370E	C213	87-010-260-080		CAP,E 47-25 M 11L SME
	87-026-610-080		TR,KTC3198GR	C214	87-010-260-080		CAP,E 47-25 M 11L SME
	89-333-317-080		TR,2SC3331T	C217	87-010-993-080		C-CAP,S 0.056-25 K B MK212
	87-A30-196-080		TR,2SC4115SRS	C218	87-010-993-080		C-CAP,S 0.056-25 K B MK212
	89-113-187-880		TR,2SA1318(T/U)	C219	87-010-196-080		C-CAP,S 0.1-25 Z F C2012
	87-A30-198-080		TR,KTC3199GR	C220	87-010-196-080		C-CAP,S 0.1-25 Z F C2012
	87-A30-197-080		TR,KTA1267GR	C227	87-010-260-080		CAP,E 47-25 M 11L SME
	87-026-219-080		TR,DTA144ES	C229	87-012-156-080		C-CAP,S 220P-50 J CH GRM
	87-A30-127-010		TR,2SD2478	C230	87-012-156-080		C-CAP,S 220P-50 J CH GRM
	87-A30-126-010		TR,2SB1616	C261	87-010-197-080		C-CAP,S 0.01-25 K B C2012
	89-406-555-080		TR,2SD655E	C273	87-010-196-080		C-CAP,S 0.1-25 Z F C2012
	87-026-609-080		TR,KTA1266GR	C303	87-010-177-080		C-CAP,S 820P-50 J SL C2012
	87-026-245-080		TR,DTC114ES	C304	87-010-177-080		C-CAP,S 820P-50 J SL C2012
	89-112-965-080		TR,2SA1296GR	C307	87-010-263-080		CAP,E 100-10 M 11L SME
	89-327-125-080		C-TR,2SC2712GR	C308	87-010-263-080		CAP,E 100-10 M 11L SME
	87-A30-090-080		FET,2SK2541	C311	87-010-195-080		C-CAP,S 0.068-25 Z F C2012
	89-111-624-080		C-TR,2SA1162Y	C312	87-010-195-080		C-CAP,S 0.068-25 Z F C2012
	87-A30-076-080		C-TR,2SC3052F	C313	87-010-184-080		C-CAP,S 3300P-50 K B C2012
	87-026-235-080		C-TR,DTC114EK	C314	87-010-184-080		C-CAP,S 3300P-50 K B C2012
	87-A30-074-080		C-TR,RT1P 141C	C315	87-010-374-080		CAP,E 47-10 M 11L SME
	87-A30-087-080		C-FET,2SK2158	C317	87-010-546-080		CAP,E 0.33-50 M 11L SME
	87-026-502-080		TR,DTC144TS	C318	87-010-546-080		CAP,E 0.33-50 M 11L SME
	87-026-295-080		C-TR,DTC144TK	C320	87-010-401-080		CAP,E 1-50 M 11L SME
	87-A30-234-080		TR,CSC4115BC<EZ,K>	C321	87-010-405-080		CAP,E 10-50 M 11L SME
	89-505-434-540		C-FET,2SK543-TB (4/5) <EZ,K>	C340	87-012-156-080		C-CAP,S 220P-50 J CH GRM
	87-A30-086-070		C-TR,CSD1306E<EZ,K>	C361	87-010-374-080		CAP,E 47-10 M 11L SME
				C362	87-010-401-080		CAP,E 1-50 M 11L SME
<b>DIODE</b>				C401	87-010-401-080		CAP,E 1-50 M 11L SME
	87-A40-454-080		DIODE,1N5393 GW	C402	87-010-401-080		CAP,E 1-50 M 11L SME
	87-020-465-080		DIODE,1SS133	C403	87-010-321-080		C-CAP,S 82P-50 J CH
	87-A40-553-080		DIODE,1N4003 LES	C404	87-010-321-080		C-CAP,S 82P-50 J CH
	87-A40-781-080		ZENER,UZ36BSA	C405	87-010-188-080		C-CAP,S 6800P-50 K B C2012
	87-A40-764-080		ZENER,UZ10BSC	C406	87-010-188-080		C-CAP,S 6800P-50 K B C2012
	87-001-731-080		ZENER,HZS6C2L	C407	87-010-426-080		C-CAP,S 0.012-25 K B
	87-020-027-080		C-DIODE,1SS184	C408	87-010-426-080		C-CAP,S 0.012-25 K B
	87-A40-739-080		ZENER,UZ2.7BSA	C451	87-010-198-080		C-CAP,S 0.022-25 K B C2012
	87-A40-270-080		C-DIODE,MC2838	C452	87-010-382-080		CAP,E 22-25 M 11L SME
<b>MAIN C.B</b>				C453	87-010-183-080		C-CAP,S 2700P-50 K B GRM
C101	87-016-495-000		CAP,E 3300-25 M SMG	C454	87-010-183-080		C-CAP,S 2700P-50 K B GRM
C102	87-010-197-080		C-CAP,S 0.01-25 K B C2012	C455	87-010-183-080		C-CAP,S 2700P-50 K B GRM
C104	87-A10-011-090		CAP,E 2200-25 SMG	C456	87-010-197-080		C-CAP,S 0.01-25 K B C2012
C105	87-012-140-080		C-CAP,S 470P-50 J CH	C457	87-A10-772-080		CAP,M 5600P-50 J
C106	87-010-408-080		CAP,E 47-50 M 11L SME	C458	87-010-178-080		C-CAP,S 1000P-50 K B C2012
				C459	87-010-175-080		C-CAP,S 560P-50 J SL
				C461	87-012-158-080		C-CAP,S 390P-50 J CH GRM
				C462	87-012-158-080		C-CAP,S 390P-50 J CH GRM
				C601	87-010-180-080		C-CAP,S 1500P-50 K B C2012

REF. NO.	PART NO.	KANRI NO.	DESCRIPTION	REF. NO.	PART NO.	KANRI NO.	DESCRIPTION
C602	87-010-180-080		C-CAP,S 1500P-50 K B C2012	C327	87-010-320-080		C-CAP,S 68P-50 J CH GRM
C603	87-010-322-080		C-CAP,S 100P-50 J CH GRM	C328	87-010-320-080		C-CAP,S 68P-50 J CH GRM
C609	87-012-287-080		C-CAP,U 0.015-25 Z F	C329	87-010-198-080		C-CAP,S 0.022-25 K B C2012
C610	87-010-213-080		C-CAP,S 0.015-25 K B GRM	C330	87-010-318-080		C-CAP,S 47P-50 J CH GRM
C611	87-010-545-080		CAP,E 0.22-50 M 11L SME	C331	87-010-312-080		C-CAP,S 15P-50 J CH GRM
C612	87-010-545-080		CAP,E 0.22-50 M 11L SME	C333	87-010-401-040		CAP,E 1-50 M 11L SME
C613	87-010-545-080		CAP,E 0.22-50 M 11L SME	C335	87-010-316-080		C-CAP,S 33P-50 J CH GRM
C614	87-010-545-080		CAP,E 0.22-50 M 11L SME	C338	87-010-197-080		C-CAP,S 0.01-25 K B C2012
C615	87-010-154-080		C-CAP,S 10P-50 D CH GRM	C339	87-010-197-080		C-CAP,S 0.01-25 K B C2012
C616	87-010-408-080		CAP,E 47-50 M 11L SME	C340	87-010-197-080		C-CAP,S 0.01-25 K B C2012
C617	87-010-408-080		CAP,E 47-50 M 11L SME	C341	87-010-263-040		CAP,E 100-10 M 11L SME
C619	87-010-401-080		CAP,E 1-50 M 11L SME	C352	87-010-194-080		C-CAP,S 0.047-25 Z F
C620	87-010-401-080		CAP,E 1-50 M 11L SME	C395	87-012-154-080		C-CAP,S 150P-50 J CH GRM
C627	87-010-197-080		C-CAP,S 0.01-25 K B C2012	C397	87-012-154-080		C-CAP,S 150P-50 J CH GRM
C628	87-010-197-080		C-CAP,S 0.01-25 K B C2012	C399	87-010-314-080		C-CAP,S 22P-50 J CH GRM
C635	87-015-785-080		C-CAP, 0.1-25 Z F C3216	C400	87-012-154-080		C-CAP,S 150P-50 J CH GRM
C663	87-010-196-080		C-CAP,S 0.1-25 Z F C2012	C420	87-010-196-080		C-CAP,S 0.1-25 Z F C2012
C697	87-010-197-080		C-CAP,S 0.01-25 K B C2012	C421	87-010-318-080		C-CAP,S 47P-50 J CH GRM
C698	87-010-197-080		C-CAP,S 0.01-25 K B C2012	C422	87-010-197-080		C-CAP,S 0.01-25 K B C2012
C901	87-A10-207-080		CAP,TC U 0.01-50 K B UPO50	C423	87-010-403-040		CAP,E 3.3-50 M 11L SME
CN202	87-099-719-010		CONN,30P H BLK TYK-B(X)	CN004	87-099-032-010		CONN,15P H BLK 6216
CN351	88-CL4-701-010		CONN ASSY,7P RPEH	CN301	87-099-720-010		CONN,30P BLK TYK-B(P)
CN351	87-A60-624-010		CONN,7P V 2MM JMT	CN302	87-CL4-704-010		CONN ASSY,9P DECK
CN702	87-099-570-010		CONN,13P V<EXCEPT 121,151,152EZ>	FL301	8A-CL9-682-010		FL,11-BT-179GNK
CN702	87-A60-189-010		CONN,16P V<121,151,152EZ>	JW405	87-A90-896-080		F-BEAD, 035600STY7
J231	87-A60-420-010		JACK,3.5 ST (MSC)	JW472	87-A90-896-080		F-BEAD, 035600STY7
J241	87-A60-217-010		TERMINAL,SPKR 4P	LED301	87-A40-229-040		LED,SLR-342VR TB7 RED
J601	87-A60-881-010		JACK,PIN 2P MSP 242V05 PBSN	LED302	87-A40-619-040		LED,SLR-56PT-T31-W GRN
J603	87-099-801-010		JACK,PIN 1P BLK W/O SW	LED303	87-A40-619-040		LED,SLR-56PT-T31-W GRN
JW50	87-A90-896-080		F-BEAD, 035600STY7<K,EZ>	LED304	87-A40-619-040		LED,SLR-56PT-T31-W GRN
JW69	87-A90-896-080		F-BEAD, 035600STY7<K,EZ>	LED305	87-A40-619-040		LED,SLR-56PT-T31-W GRN
JW568	87-A90-896-080		F-BEAD, 035600STY7<K,EZ>	△ PR301	87-026-689-080		PROTECTOR,1A 491SERIES 60V
JW569	87-A90-896-080		F-BEAD, 035600STY7<K,EZ>	S301	87-A90-095-080		SW,TACT EVQ11G04M
L096	87-003-097-080		COIL,1.0UH K LAL02<U>	S302	87-A90-095-080		SW,TACT EVQ11G04M
L201	87-005-366-010		COIL,1UH K	S303	87-A90-095-080		SW,TACT EVQ11G04M
L202	87-005-366-010		COIL,1UH K	S304	87-A90-095-080		SW,TACT EVQ11G04M
L451	87-007-342-010		COIL,OSC 85KHZ BIAS	S305	87-A90-095-080		SW,TACT EVQ11G04M
PN101	87-A90-510-010		HLD, WIRE 2.5-9P	S306	87-A90-095-080		SW,TACT EVQ11G04M
△ PR201	87-A90-473-080		PROTECTOR,3.5A 491SERIES 60V	S307	87-A90-095-080		SW,TACT EVQ11G04M
△ PR202	87-A90-473-080		PROTECTOR,3.5A 491SERIES 60V	S308	87-A90-095-080		SW,TACT EVQ11G04M
R223	87-A00-258-080		RES,M/F 0.22-1W J	S309	87-A90-095-080		SW,TACT EVQ11G04M
R224	87-A00-258-080		RES,M/F 0.22-1W J	S310	87-A90-095-080		SW,TACT EVQ11G04M
R249	87-A00-258-080		RES,M/F 0.22-1W J	S311	87-A90-095-080		SW,TACT EVQ11G04M
R250	87-A00-258-080		RES,M/F 0.22-1W J	S312	87-A90-095-080		SW,TACT EVQ11G04M
WH101	8A-CL9-671-010		F-CABLE,9P 2.5	S313	87-A90-095-080		SW,TACT EVQ11G04M
FRONT C.B				S314	87-A90-095-080		SW,TACT EVQ11G04M
C300	87-012-153-080		C-CAP,S 120P-50 J CH GRM	S315	87-A90-095-080		SW,TACT EVQ11G04M
C301	87-012-145-080		C-CAP,S 270P-50 J CH GRM	S316	87-A90-095-080		SW,TACT EVQ11G04M
C302	87-010-197-080		C-CAP,S 0.01-25 K B C2012	S317	87-A90-095-080		SW,TACT EVQ11G04M
C304	87-010-405-040		CAP,E 10-50 M 11L SME	S318	87-A90-095-080		SW,TACT EVQ11G04M
C305	87-A10-797-040		CAP,E 47-35 M 5L SRM	S320	87-A90-095-080		SW,TACT EVQ11G04M
C307	87-010-421-040		CAP,E 4.7-50 M 5L SRE	S351	87-A91-690-010		SW,RTRY JOG RE0121PVB25FINB
C308	87-010-421-040		CAP,E 4.7-50 M 5L SRE	X301	87-030-375-080		VIB,CER 4.194MHZ CSA MG200
C309	87-010-787-080		C-CAP,U 0.022-25 K B	CD C.B			
C313	87-010-112-040		CAP,E 100-16 M 11L SME	C001	87-010-403-080		CAP,E 3.3-50 M 11L SME
C314	87-A10-189-040		CAP,E 220-10 M 5L	C002	87-010-197-080		C-CAP,S 0.01-25 K B C2012
C315	87-010-198-080		C-CAP,S 0.022-25 K B C2012	C003	87-010-263-080		CAP,E 100-10 M 11L SME
C316	87-012-286-080		C-CAP,U 0.01-25 K B	C004	87-010-248-080		CAP,E 220-10 M 11L SME
C317	87-010-787-080		C-CAP,U 0.022-25 K B	C005	87-010-197-080		C-CAP,S 0.01-25 K B C2012
C318	87-010-320-080		C-CAP,S 68P-50 J CH GRM	C006	87-010-374-080		CAP,E 47-10 M 11L SME
C319	87-010-320-080		C-CAP,S 68P-50 J CH GRM	C007	87-012-349-080		C-CAP,S 1000P-50 J CH GRM
C320	87-010-320-080		C-CAP,S 68P-50 J CH GRM	C008	87-010-198-080		C-CAP,S 0.022-25 K B C2012
C321	87-010-320-080		C-CAP,S 68P-50 J CH GRM	C009	87-010-263-080		CAP,E 100-10 M 11L SME
C322	87-010-320-080		C-CAP,S 68P-50 J CH GRM	C010	87-010-263-080		CAP,E 100-10 M 11L SME
C323	87-010-320-080		C-CAP,S 68P-50 J CH GRM	C012	87-010-401-080		CAP,E 1-50 M 11L SME
C324	87-010-320-080		C-CAP,S 68P-50 J CH GRM	C013	87-010-197-080		C-CAP,S 0.01-25 K B C2012
C325	87-010-320-080		C-CAP,S 68P-50 J CH GRM	C014	87-010-405-080		CAP,E 10-50 M 11L SME
C326	87-010-320-080		C-CAP,S 68P-50 J CH GRM	C016	87-010-545-080		CAP,E 0.22-50 M 11L SME

REF. NO.	PART NO.	KANRI NO.	DESCRIPTION	REF. NO.	PART NO.	KANRI NO.	DESCRIPTION
C017	87-012-349-080		C-CAP,S 1000P-50 J CH GRM	R073	87-029-361-090		RES,FUSE 3.3-1/2W J
C018	87-010-213-080		C-CAP,S 0.015-25 K B GRM	X001	87-A70-046-010		VIB,XTAL 16.934MHZ
C020	87-010-193-080		C-CAP,S 0.033-25 Z F C2012				
C021	87-A10-306-080		CAP,M 0.082-50 J				
C023	87-010-992-080		C-CAP,S 0.047-25 K B MK212	PT C.B			
C029	87-010-186-080		C-CAP,S 4700P-50 K B C2012	C101	87-010-387-080		CAP,E 470-25 M SME
C030	87-012-156-080		C-CAP,S 220P-50 J CH GRM	CN101	87-A61-110-010		CONN,9P V TID-A
C031	87-010-545-080		CAP,E 0.22-50 M 11L SME	△ F101	87-035-454-010		FUSE,1.6A 250V T 218<HR,HT>
C032	87-010-374-080		CAP,E 47-10 M 11L SME	△ FC101	87-033-213-080		FUSE CLAMP,PFC5000<HR,HT>
C033	87-010-401-080		CAP,E 1-50 M 11L SME	△ FC102	87-033-213-080		FUSE CLAMP,PFC5000<HR,HT>
C034	87-010-182-080		C-CAP,S 2200P-50 K B C2012	△ PR101	87-026-690-080		FUSE,5A 125V 251<U>
C035	87-010-197-080		C-CAP,S 0.01-25 K B C2012	△ PR101	87-026-681-080		PROTECTOR,5A 491SERIES 60V
C036	87-010-374-080		CAP,E 47-10 M 11L SME	△ PR102	87-026-681-080		PROTECTOR,5A 491SERIES 60V
C037	87-010-405-080		CAP,E 10-50 M 11L SME	△ PT101	8A-CL9-644-010		PT,LH<HR,HT>
C038	87-010-196-080		C-CAP,S 0.1-25 Z F C2012	△ PT101	8A-CL9-643-010		PT,EZ<EZ,K>
C039	87-012-349-080		C-CAP,S 1000P-50 J CH GRM	△ PT102	8A-NF8-673-010		PT,SUB ANF-8 (H)KAMI<HR,HT>
C040	87-010-148-080		C-CAP,S 4P-50 C CH GRM	△ PT102	8A-NF8-662-010		PT,SUB ANF-8 (E)<EZ,K>
C041	87-A10-294-080		CAP,M 8200P-50 J	△ RY102	87-A91-281-010		RELAY,AC DC12V OSA-SS-212DM5
C042	87-010-313-080		C-CAP,S 18P-50 J CH GRM	△ SW101	87-A90-234-010		SW,SL 1-2-2 SWS2201<HR,HT>
C045	87-010-196-080		C-CAP,S 0.1-25 Z F C2012	△ T101	87-A60-317-010		TERMINAL, 1P MSC
C046	87-010-196-080		C-CAP,S 0.1-25 Z F C2012	△ T102	87-A60-317-010		TERMINAL, 1P MSC
C047	87-010-196-080		C-CAP,S 0.1-25 Z F C2012				
C048	87-010-315-080		C-CAP,S 27P-50 J CH GRM				
C050	87-012-140-080		C-CAP,S 470P-50 J CH	TUNER C.B<100EZ,120,150K>			
C051	87-010-994-080		C-CAP,S 680P-50 J CH				
C057	87-010-316-080		C-CAP,S 33P-50 J CH GRM	C701	87-010-381-080		CAP,ELECT 330-16V
C058	87-010-316-080		C-CAP,S 33P-50 J CH GRM	C702	87-010-404-080		CAP,ELECT 4.7-50V
C059	87-010-263-080		CAP,E 100-10 M 11L SME	C703	87-012-286-080		CAP,U 0.01-25
C060	87-010-196-080		C-CAP,S 0.1-25 Z F C2012	C704	87-012-286-080		CAP,U 0.01-25
C061	87-010-196-080		C-CAP,S 0.1-25 Z F C2012	C709	87-012-195-080		C-CAP,U 100P-50CH
C062	87-010-370-080		CAP,E 330-6.3 M SME	C711	87-010-260-080		CAP,ELECT 47-25V
C065	87-010-404-080		CAP,E 4.7-50 M 11L SME	C712	87-010-831-080		C-CAP,U,0.1-16F
C066	87-010-196-080		C-CAP,S 0.1-25 Z F C2012	C713	87-012-286-080		CAP,U 0.01-25
C067	87-010-263-080		CAP,E 100-10 M 11L SME	C714	87-012-286-080		CAP,U 0.01-25
C075	87-010-197-080		C-CAP,S 0.01-25 K B C2012	C715	87-012-195-080		C-CAP,U 100P-50CH
C076	87-A10-102-080		CAP,E 1000-10 REA	C717	87-012-286-080		CAP,U 0.01-25
C077	87-010-263-080		CAP,E 100-10 M 11L SME	C719	87-012-286-080		CAP,U 0.01-25
C078	87-010-197-080		C-CAP,S 0.01-25 K B C2012	C720	87-012-195-080		C-CAP,U 100P-50CH
C079	87-010-197-080		C-CAP,S 0.01-25 K B C2012	C721	87-012-176-080		CAP,15P
C080	87-010-112-080		CAP,E 100-16 M 11L SME	C722	87-012-176-080		CAP,15P
C081	87-010-405-080		CAP,E 10-50 M 11L SME	C723	87-012-274-080		CHIP CAP,U 1000P-50B
C082	87-010-405-080		CAP,E 10-50 M 11L SME	C725	87-018-131-080		CAP,TC U 1000P-50 KB
C083	87-010-181-080		C-CAP,S 1800P-50 K B GRM	C727	87-010-196-080		CHIP CAPACITOR,0.1-25
C084	87-010-181-080		C-CAP,S 1800P-50 K B GRM	C728	87-010-248-080		CAP,ELECT 220-10V
C090	87-010-197-080		C-CAP,S 0.01-25 K B C2012	C729	87-012-274-080		CHIP CAP,U 1000P-50B
C091	87-010-404-080		CAP,E 4.7-50 M 11L SME	C731	87-012-286-080		CAP,U 0.01-25
C092	87-010-387-080		CAP,E 470-25 M SME	C733	87-012-280-080		C-CAP,U 3300P-50 KB
C093	87-010-197-080		C-CAP,S 0.01-25 K B C2012	C734	87-012-280-080		C-CAP,U 3300P-50 KB
C094	87-010-197-080		C-CAP,S 0.01-25 K B C2012	C752	87-012-282-080		C-CAP,U 4700P-50 KB
C095	87-010-197-080		C-CAP,S 0.01-25 K B C2012	C753	87-012-195-080		C-CAP,U 100P-50 J CH
C096	87-010-221-080		CAP,E 470-10 M SME	C755	87-012-286-080		CAP,U 0.01-25
C097	87-010-197-080		C-CAP,S 0.01-25 K B C2012	C756	87-012-286-080		CAP,U 0.01-25
C098	87-012-154-080		C-CAP,S 150P-50 J CH GRM	C757	87-012-188-080		C-CAP,U 47P-50 CH
C104	87-010-322-080		C-CAP,S 100P-50 J CH GRM	C758	87-012-167-080		C-CAP,U 5P-50 CH
C105	87-010-322-080		C-CAP,S 100P-50 J CH GRM	C761	87-010-196-080		C-CAP,S 0.1-25 ZF
C110	87-010-196-080		C-CAP,S 0.1-25 Z F C2012	C762	87-012-286-080		CAP,U 0.01-25
C162	87-010-178-080		C-CAP,S 1000P-50 K B C2012	C763	87-010-829-080		CAP,U 0.047-16
C902	87-018-119-080		CAP,TC U 100P-50 K B UP050	C765	87-012-286-080		CAP,U 0.01-25
C903	87-018-119-080		CAP,TC U 100P-50 K B UP050	C766	87-010-197-080		C-CAP,S 0.01-25 KB
CN001	87-A60-424-010		CONN,16P V TOC-B	C768	87-012-286-080		CAP,U 0.01-25
CN003	87-A60-131-010		CONN,6P V FE	C769	87-010-260-080		CAP,ELECT 47-25V
CN004	87-099-032-010		CONN,15P H BLK 6216	C770	87-010-829-080		CAP,U 0.047-16
CN006	87-A60-153-010		CONN,5P H FE	C771	87-010-383-080		CAP,ELECT 33-25V
FFC001	88-CL4-704-010		FF-CABLE, 16P 1.0	C772	87-010-829-080		CAP,U 0.047-16
FFC003	88-906-131-110		FF-CABLE,6P 1.25	C773	87-010-196-080		CHIP CAPACITOR,0.1-25
FFC004	88-915-231-110		FF-CABLE, 15P 1.25 230MM	C774	87-010-263-080		CAP,ELECT 100-10V
FFC006	88-905-231-110		FF-CABLE, 5P 1.25 230MM	C775	87-010-404-080		CAP,ELECT 4.7-50V
JR161	83-XM1-617-080		C-COIL,BK2125HM601	C776	87-012-286-080		CAP,U 0.01-25
L001	87-003-102-080		COIL,10UH J LAL02	C777	87-010-493-080		CAP,E 0.47-50 M 5L SRE
R070	87-029-124-090		RES,FUSE 2.2-1/4W J	C778	87-010-401-080		CAP,ELECT 1-50V

REF. NO.	PART NO.	KANRI NO.	DESCRIPTION	REF. NO.	PART NO.	KANRI NO.	DESCRIPTION
C779	87-010-401-080		CAP,ELECT 1-50V	C722	87-012-176-080		CAP,15P
C780	87-010-196-080		CHIP CAPACITOR,0.1-25	C723	87-012-274-080		CHIP CAP,U 1000P-50B
C781	87-010-405-080		CAP,ELECT 10-50V	C725	87-018-131-080		CAP,TC U 1000P-50 KB
C782	87-010-405-080		CAP,ELECT 10-50V	C727	87-010-196-080		CHIP CAPACITOR,0.1-25
C783	87-012-286-080		CAP,U 0.01-25	C728	87-010-248-080		CAP,ELECT 220-10V
C784	87-012-286-080		CAP,U 0.01-25	C729	87-012-274-080		CHIP CAP,U 1000P-50B
C785	87-010-402-080		CAP, ELECT 2.2-50V	C731	87-012-286-080		CAP,U 0.01-25
C786	87-010-402-080		CAP,ELECT 2.2-50V	C733	87-012-280-080		C-CAP,U 3300P-50 KB
C787	87-012-275-080		C-CAP,U 1200P-50 B	C734	87-012-280-080		C-CAP,U 3300P-50 KB
C788	87-012-275-080		C-CAP,U 1200P-50 B	C752	87-012-282-080		C-CAP,U 4700P-50 KB
C789	87-012-275-080		C-CAP,U 1200P-50 B	C753	87-012-195-080		C-CAP,U 100P-50 J CH
C790	87-012-275-080		C-CAP,U 1200P-50 B	C755	87-012-286-080		CAP,U 0.01-25
C791	87-010-405-080		CAP,ELECT 10-50V	C756	87-012-286-080		CAP,U 0.01-25
C793	87-012-273-080		C-CAP,U 820P-50 B	C757	87-012-188-080		C-CAP,U 47P-50 CH
C794	87-010-406-080		CAP,ELECT 22-50	C758	87-012-167-080		C-CAP,U 5P-50 CH
C795	87-010-596-080		CAP,S 0.047-16	C761	87-010-196-080		C-CAP,S 0.1-25 ZF
C796	87-010-403-080		CAP,ELECT 3.3-50V	C762	87-012-286-080		CAP,U 0.01-25
C797	87-012-276-080		C-CAP,U 1500P-50 KB	C763	87-010-829-080		CAP,U 0.047-16
C798	87-012-276-080		C-CAP,U 1500P-50 KB	C765	87-012-286-080		CAP,U 0.01-25
C799	87-010-829-080		CAP,U 0.047-16	C766	87-010-197-080		C-CAP,S 0.01-25 KB
C812	87-012-286-080		CAP,U 0.01-25	C768	87-012-286-080		CAP,U 0.01-25
C814	87-012-286-080		CAP,U 0.01-25	C769	87-010-260-080		CAP,ELECT 47-25V
C820	87-010-260-080		CAP,ELECT 47-25V	C770	87-010-829-080		CAP,U 0.047-16
C821	87-012-286-080		CAP,U 0.01-25	C771	87-010-383-080		CAP,ELECT 33-25V
C822	87-012-286-080		CAP,U 0.01-25	C772	87-010-829-080		CAP,U 0.047-16
C823	87-012-286-080		CAP,U 0.01-25	C773	87-010-196-080		CHIP CAPACITOR,0.1-25
C828	87-010-196-080		CHIP CAPACITOR,0.1-25	C774	87-010-263-080		CAP,ELECT 100-10V
C829	87-010-196-080		CHIP CAPACITOR,0.1-25	C775	87-010-404-080		CAP,ELECT 4.7-50V
C940	87-012-286-080		C-CAP,U 0.01-25 KB	C776	87-012-286-080		CAP,U 0.01-25
C942	87-012-168-080		C-CAP,U 6P-50 D CH	C777	87-010-493-080		CAP,E 0.47-50 M 5L SRE
C947	87-012-286-080		C-CAP,U 0.01-25 KB	C778	87-010-401-080		CAP,ELECT 1-50V
C949	87-A10-039-080		C-CAP,U 470P-50 J CH	C779	87-010-401-080		CAP,ELECT 1-50V
C952	87-012-286-080		C-CAP,U 0.01-25 KB	C780	87-010-196-080		CHIP CAPACITOR,0.1-25
C958	87-010-197-080		C-CAP,S 0.01-25 KB	C781	87-010-405-080		CAP,ELECT 10-50V
C959	87-010-831-080		C-CAP,U 0.1-16 ZF	C782	87-010-405-080		CAP,ELECT 10-50V
C960	87-010-196-080		CHIP CAPACITOR,0.1-25	C783	87-012-286-080		CAP,U 0.01-25
C962	87-010-401-080		CAP,E 1-50 M 11L SME	C784	87-012-286-080		CAP,U 0.01-25
CF801	87-008-423-010		FLTR,CF SFE10.7MS3G-A	C785	87-010-401-080		CAP,ELECT 1-50V
CF802	82-785-747-010		CF,MS2 GHY R	C786	87-010-401-080		CAP,ELECT 1-50V
CN701	87-A60-700-010		CONN,13P H GRY TUC-P13X-C1	C787	87-012-275-080		C-CAP,U 1200P-50 B
FFE801	A8-6ZA-19H-030		6ZA-1 FEMENM	C788	87-012-275-080		C-CAP,U 1200P-50 B
J801	87-033-241-010		TERMINAL,ANT 2P AJ-2039	C789	87-012-275-080		C-CAP,U 1200P-50 B
L771	87-A50-266-010		COIL,FM DET-2N(TOK)	C790	87-012-275-080		C-CAP,U 1200P-50 B
L772	87-A91-110-010		FLTR,PCFJZH-450 (TOK)	C791	87-010-405-080		CAP,ELECT 10-50V
L781	87-005-847-080		COIL,2.2UH (CECS)	C793	87-012-273-080		C-CAP,U 820P-50 B
L791	87-A50-027-010		COIL,1 POLE MPX(TOK)	C794	87-010-406-080		CAP,ELECT 22-50
L792	87-A50-027-010		COIL,1 POLE MPX(TOK)	C795	87-010-596-080		CAP,S 0.047-16
L832	87-005-847-080		COIL,2.2UH K CECS	C796	87-010-403-080		CAP,ELECT 3.3-50V
L941	87-A50-020-010		COIL,ANT LW(COI)252KHZ	C797	87-012-276-080		CAP,CHIP SS 1500 PBK
L942	87-A50-019-010		COIL,OSC LW(COI) 856KHZ	C798	87-012-276-080		CAP,CHIP SS 1500 PBK
L981	8Z-ZA1-665-010		COIL,AM PACK 2(TOK)	C799	87-010-829-080		CAP,U 0.047-16
TC942	87-A91-658-010		TRIMMER,30P 4.0X4.5 ECRL	C812	87-012-286-080		CAP,U 0.01-25
X721	87-A70-061-010		VIB,XTAL 4.500MHZ CSA-309	C814	87-012-286-080		CAP,U 0.01-25
TUNER C.B<121,151,152EZ>				C820	87-010-260-080		CAP,ELECT 47-25V
C701	87-010-381-080		CAP,ELECT 330-16V	C821	87-012-286-080		CAP,U 0.01-25
C702	87-010-404-080		CAP,ELECT 4.7-50V	C822	87-012-286-080		CAP,U 0.01-25
C703	87-012-286-080		CAP,U 0.01-25	C823	87-012-286-080		CAP,U 0.01-25
C704	87-012-286-080		CAP,U 0.01-25	C828	87-010-196-080		CHIP CAPACITOR,0.1-25
C709	87-012-195-080		C-CAP,U 100P-50CH	C829	87-010-196-080		CHIP CAPACITOR,0.1-25
C711	87-010-260-080		CAP,ELECT 47-25V	C859	87-012-286-080		C-CAP,U 0.01-25 KB
C712	87-010-831-080		C-CAP,U,0.1-16F	C861	87-012-199-080		C-CAP,U 220P-50 J CH
C713	87-012-286-080		CAP,U 0.01-25	C862	87-012-199-080		C-CAP,U 220P-50 J CH
C714	87-012-286-080		CAP,U 0.01-25	C863	87-012-270-080		C-CAP,U 470P-50 KB
C715	87-012-195-080		C-CAP,U 100P-50CH	C864	87-010-405-080		CAP,E 10-50 M 11L SME
C717	87-012-286-080		CAP,U 0.01-25	C865	87-010-196-080		C-CAP,S 0.1-25 ZF
C719	87-012-286-080		CAP,U 0.01-25	C866	87-010-405-080		CAP,E 10-50 M 11L SME
C720	87-012-195-080		C-CAP,U 100P-50CH	C867	87-012-286-080		C-CAP,U 0.01-25 KB
C721	87-012-176-080		CAP,15P	C868	87-012-184-080		C-CAP,U 33P-50 J CH
				C869	87-012-180-080		C-CAP,U 22P-50 J CH
				C940	87-012-286-080		C-CAP,U 0.01-25 KB





REF. NO.	PART NO.	KANRI NO.	DESCRIPTION
M20	87-045-358-010		MOT,RF-310TA 43
M21	87-045-356-010		MOT,RF-310TA 30
SW1	87-A90-042-010		SW,LEAF MSW-17310MVPO

○チップ抵抗部品コード／CHIP RESISTOR PART CODE

チップ抵抗部品コードの成り立ち

Chip Resistor Part Coding

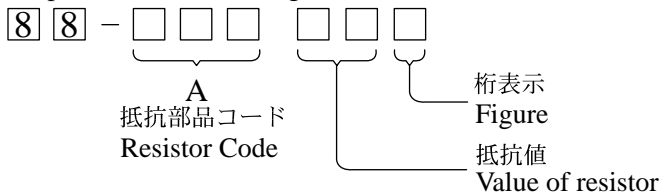

チップ抵抗  
Chip resistor

容量 Wattage	種類 Type	許容誤差 Tolerance	記号 Symbol	寸法/Dimensions (mm)			抵抗コード : A Resistor Code : A	
				外形/Form	L	W		t
1/16W	1005	± 5%	CJ		1.0	0.5	0.35	104
1/16W	1608	± 5%	CJ		1.6	0.8	0.45	108
1/10W	2125	± 5%	CJ		2	1.25	0.45	118
1/8W	3216	± 5%	CJ		3.2	1.6	0.55	128

# TRANSISTOR ILLUSTRATION

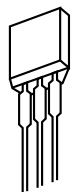

E C B

2SA933  
2SC4115  
DTA144ES  
DTC114ES  
DTC144TS  
KTA1267  
KTC3199



E C B

2SA1296  
2SC1815  
KTA1266  
KTC3198  
CSC4115



E C B

2SA952  
2SD655



E C B

2SA1318  
2SC3331

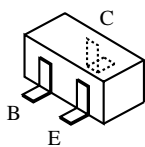

B C E

2SA1162Y DTA144TK  
2SC2712GR DTC114EK  
2SC2714 DTC114TK  
2SC3052F RT1P141C  
CSD1306E RT1P144C  
DTC144TK

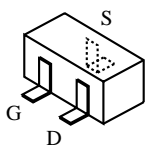

G D S

2SK2158  
2SK543-TB



B C E

2SB1616  
2SD2478



B C E

2SB1370

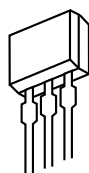

S D G

2SK2541

32	31	30	29	28	27	26	25	24	23	22	21	20	19	18	17	16	15	14	13	12	11	10	9	8	7	6	5	4	3	2	1
----	----	----	----	----	----	----	----	----	----	----	----	----	----	----	----	----	----	----	----	----	----	----	---	---	---	---	---	---	---	---	---

# A MAIN C.B

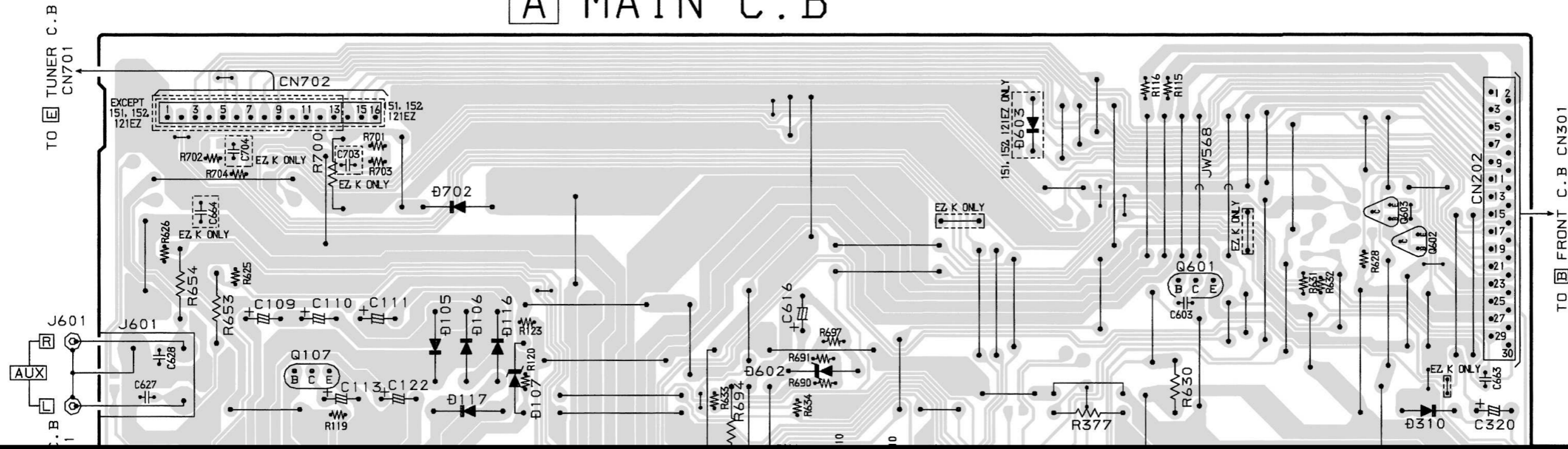

A  
B  
C  
D  
E  
F  
G  
H  
I  
J  
K  
L  
M  
N  
O  
P  
Q  
R  
S  
T  
U



WIRING - 2 (TUNER: 100EZ,120,150K)

15	14	13	12	11	10	9	8	7	6	5	4	3	2	1
----	----	----	----	----	----	---	---	---	---	---	---	---	---	---

**E** TUNER C. B

TO **A** MAIN C. B CN702

13	11	9	7	5	3	1
----	----	---	---	---	---	---

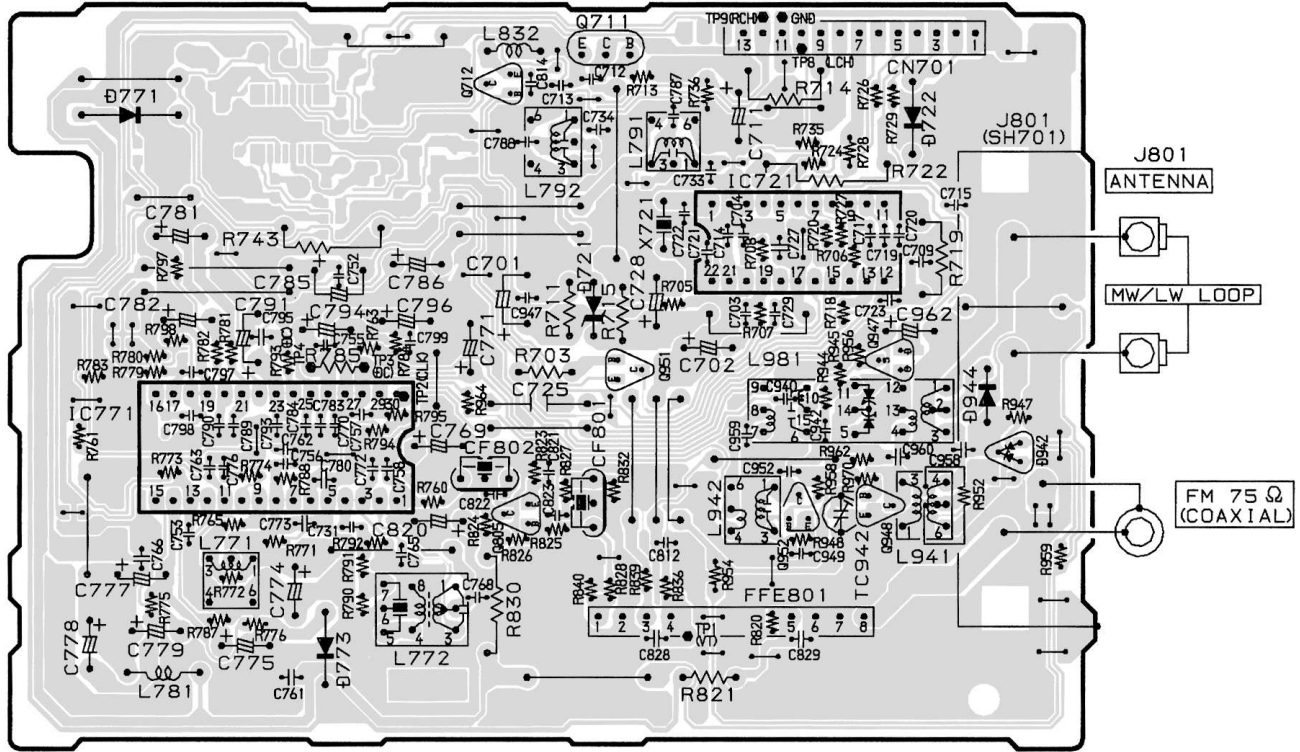

A  
B  
C  
D  
E  
F  
G  
H  
I  
J  
K  
L  
M  
N  
O  
P  
Q  
R  
S  
T  
U

SCHEMATIC DIAGRAM - 2 (TUNER: 100EZ,120,150K)

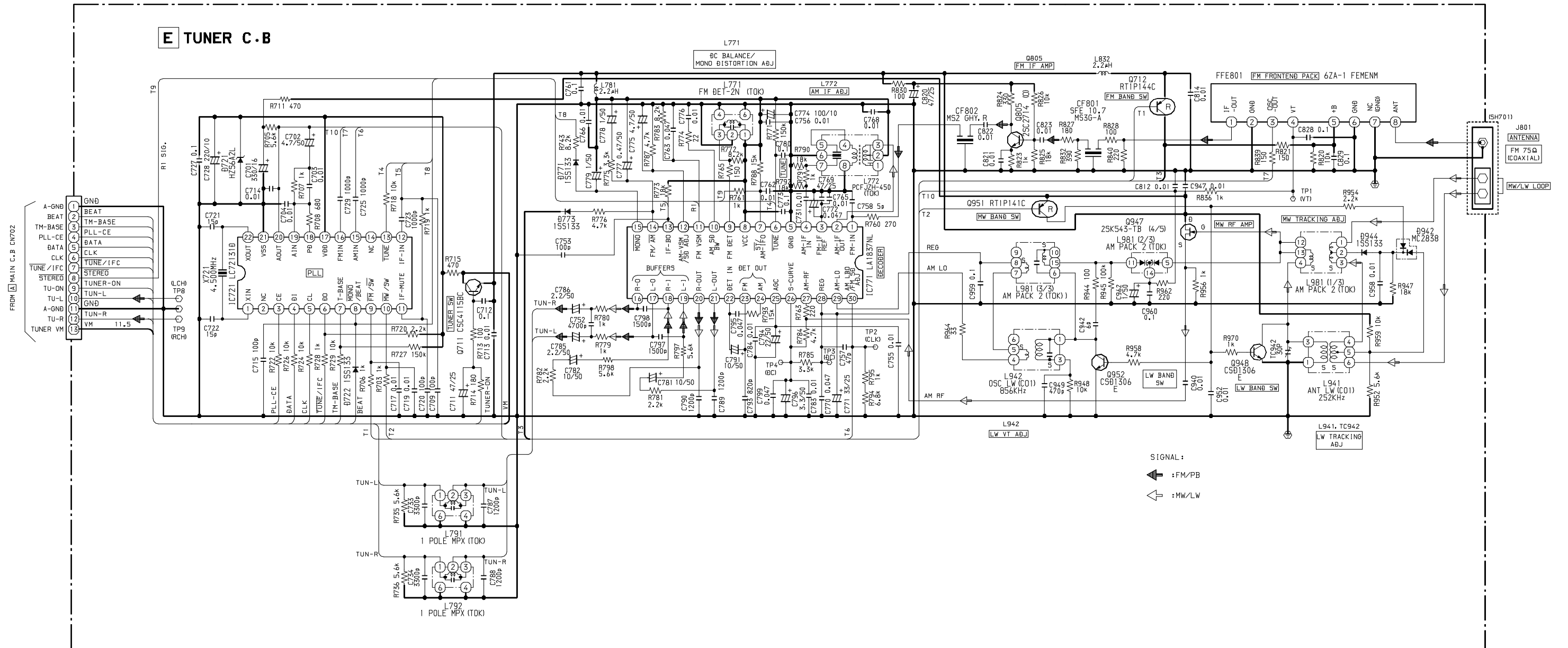

WIRING - 3 (TUNER: 121,151,152EZ)

15	14	13	12	11	10	9	8	7	6	5	4	3	2	1
----	----	----	----	----	----	---	---	---	---	---	---	---	---	---

E TUNER C. B

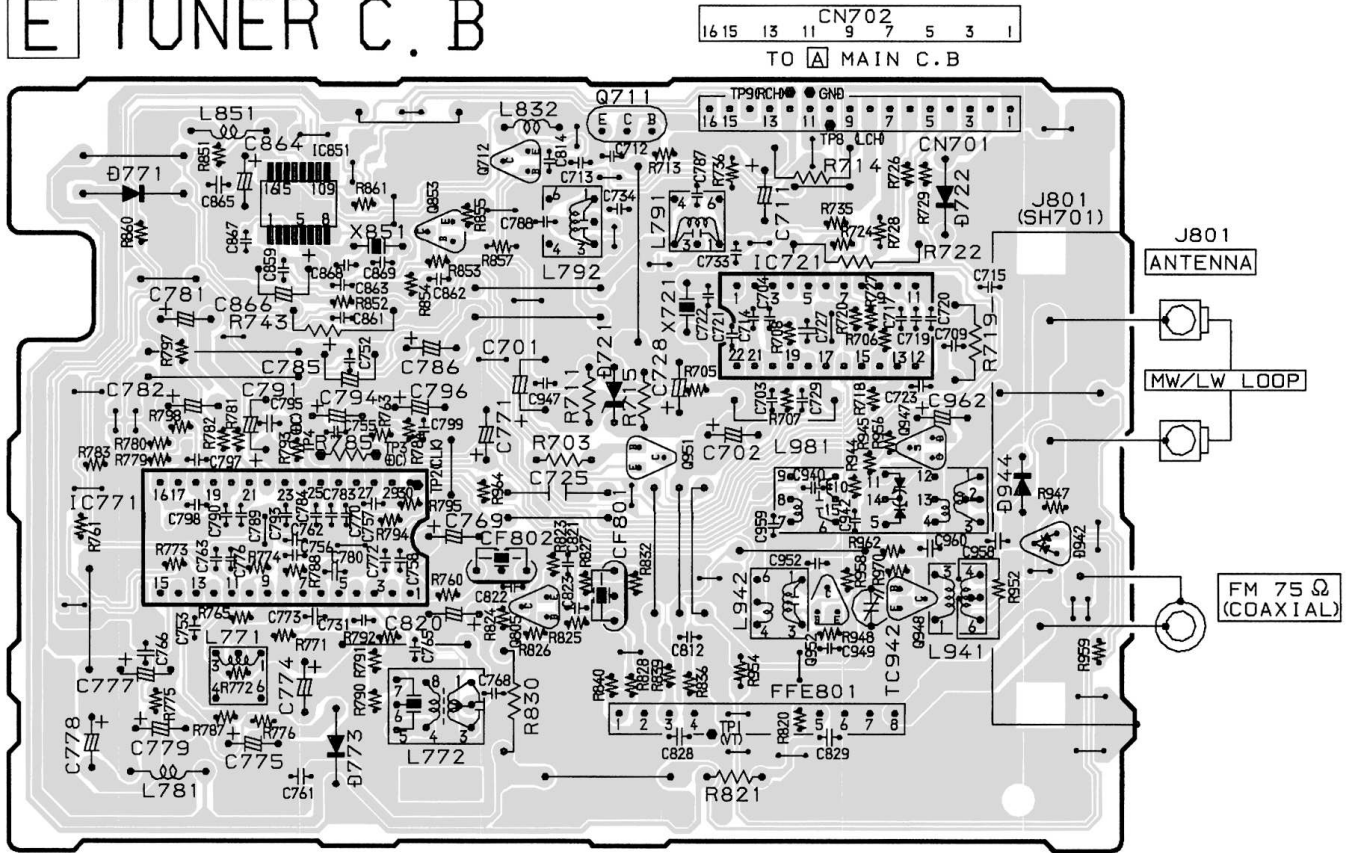

A
B
C
D
E
F
G
H
I
J
K
L
M
N
O
P
Q
R
S
T
U







SCHEMATIC DIAGRAM - 4 (TUNER: HR,HT)

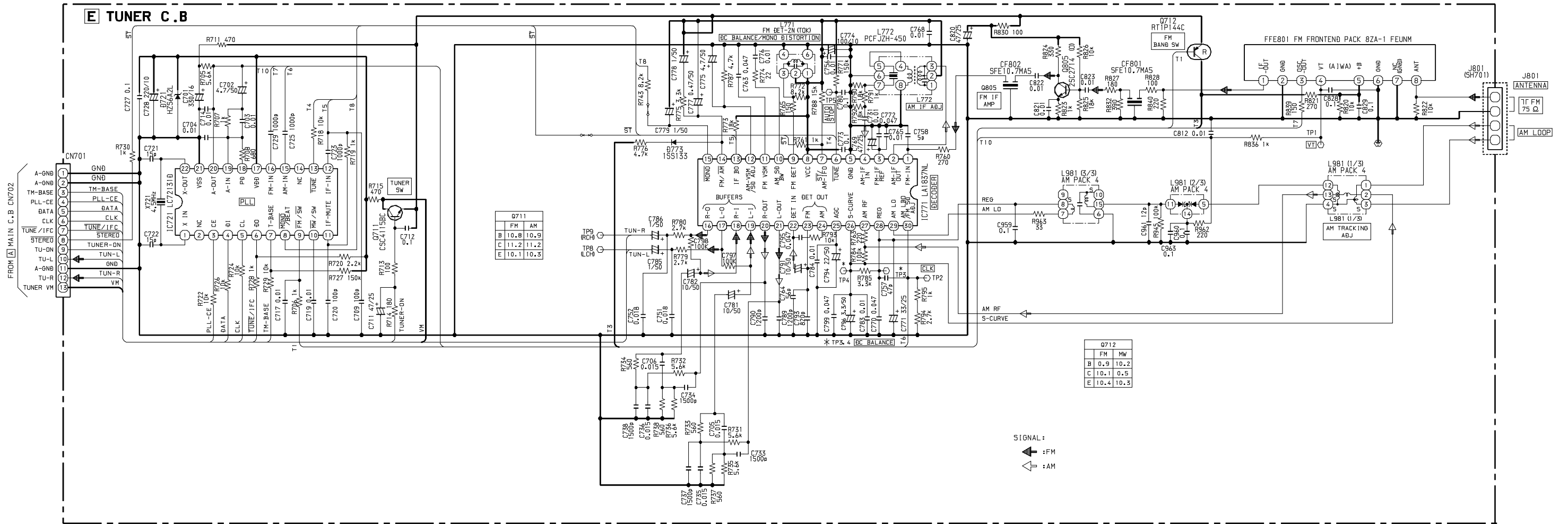

32 31 30 29 28 27 26 25 24 23 22 21 20 19 18 17 16 15 14 13 12 11 10 9 8 7 6 5 4 3 2 1

A  
B  
C  
D  
E  
F  
G  
H  
I  
J  
K  
L  
M  
N  
O  
P  
Q  
R  
S  
T  
U

**B FRONT C.B**

LED302 [CD] LED303 [AUX] LED304 [TUNER] LED305 [TAPE] LED301 [POWER]

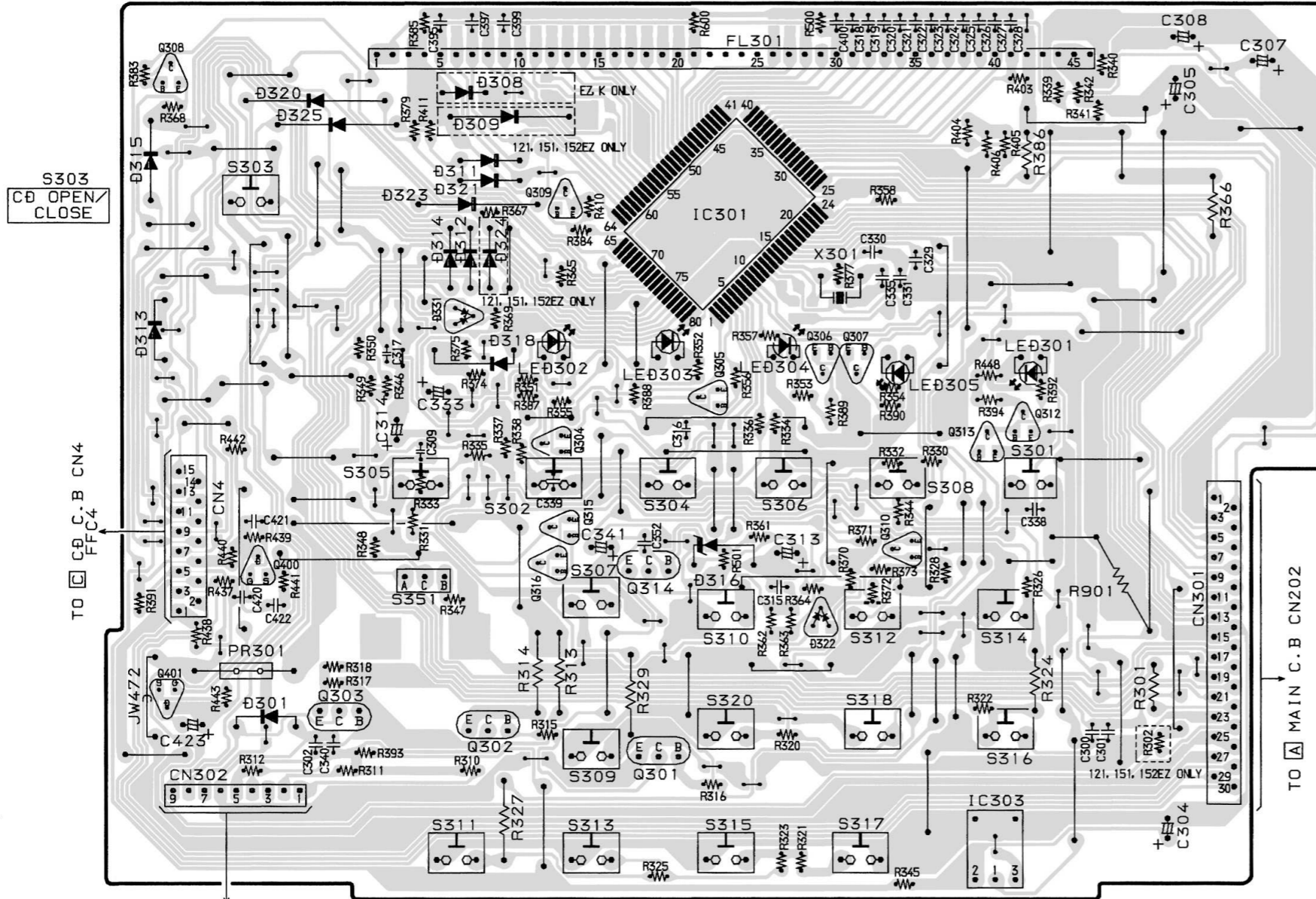

**G DECK C.B**

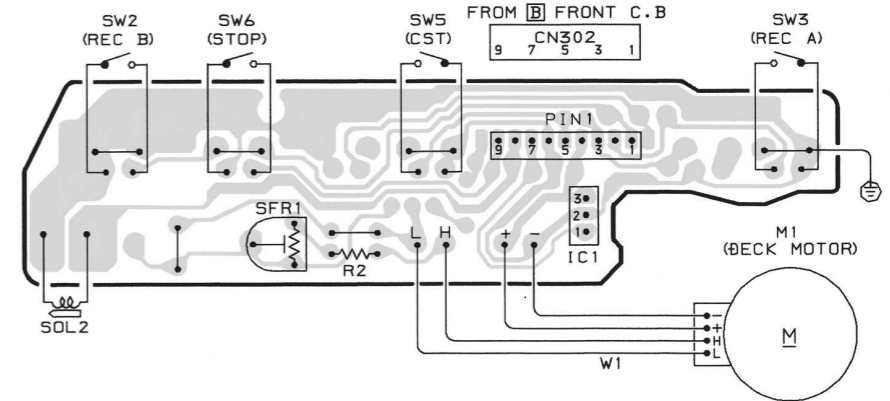

**F RELAY C.B**

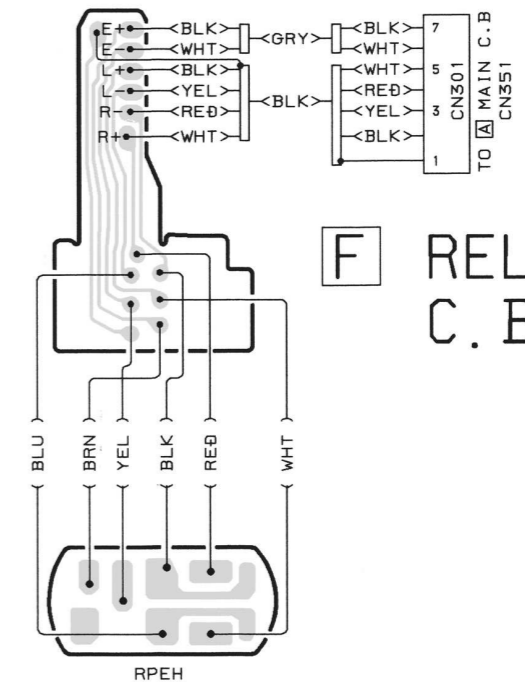

- S305 [Q SOUND]
- S302 [CD]
- S304 [AUX]
- S306 [TUNER]
- S308 [TAPE]
- S301 [POWER  
⏻ STANDBY/ON]
- S351 [VOL/MULTI JOG]
- S307 [JOG MODE]
- S310 [DIR/PRESET]
- S312 [CLEAR]
- S314 [SET]
- S311 [CD BLANK  
SKIP/RDS]
- S309 [ENTER]
- S320 [TUNING  
⏪ UP ⏩ DOWN]
- S318 [DEMO/ECO]
- S316 [● REC/RECMOTE]
- S313 [SLEEP]
- S315 [TIMER]
- S317 [IC303  
REMOTE  
SENSOR]

SCHEMATIC DIAGRAM - 5 (FRONT / DECK)

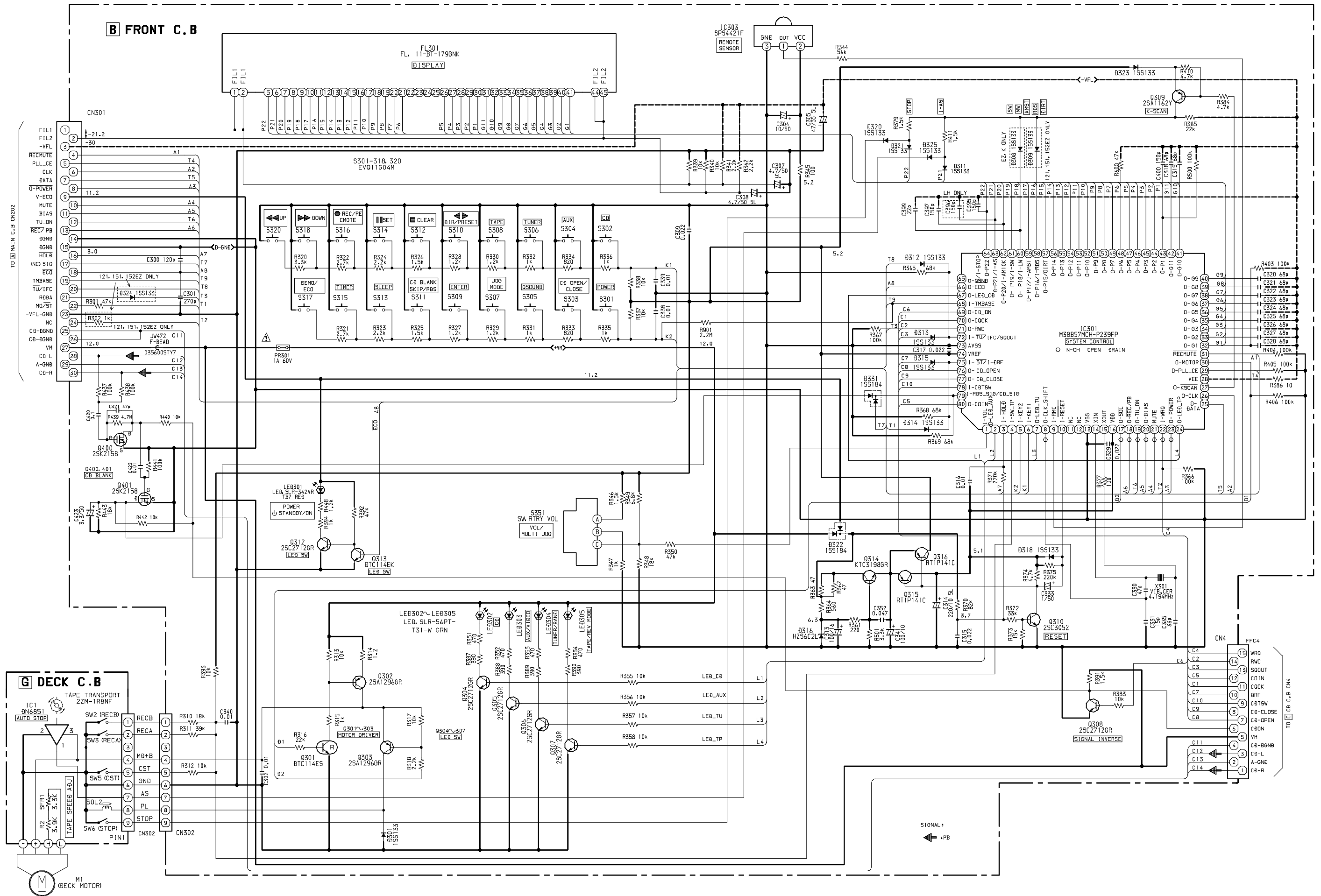



SCHEMATIC DIAGRAM - 6 (CD / CD LOAD / CD DRIVE)

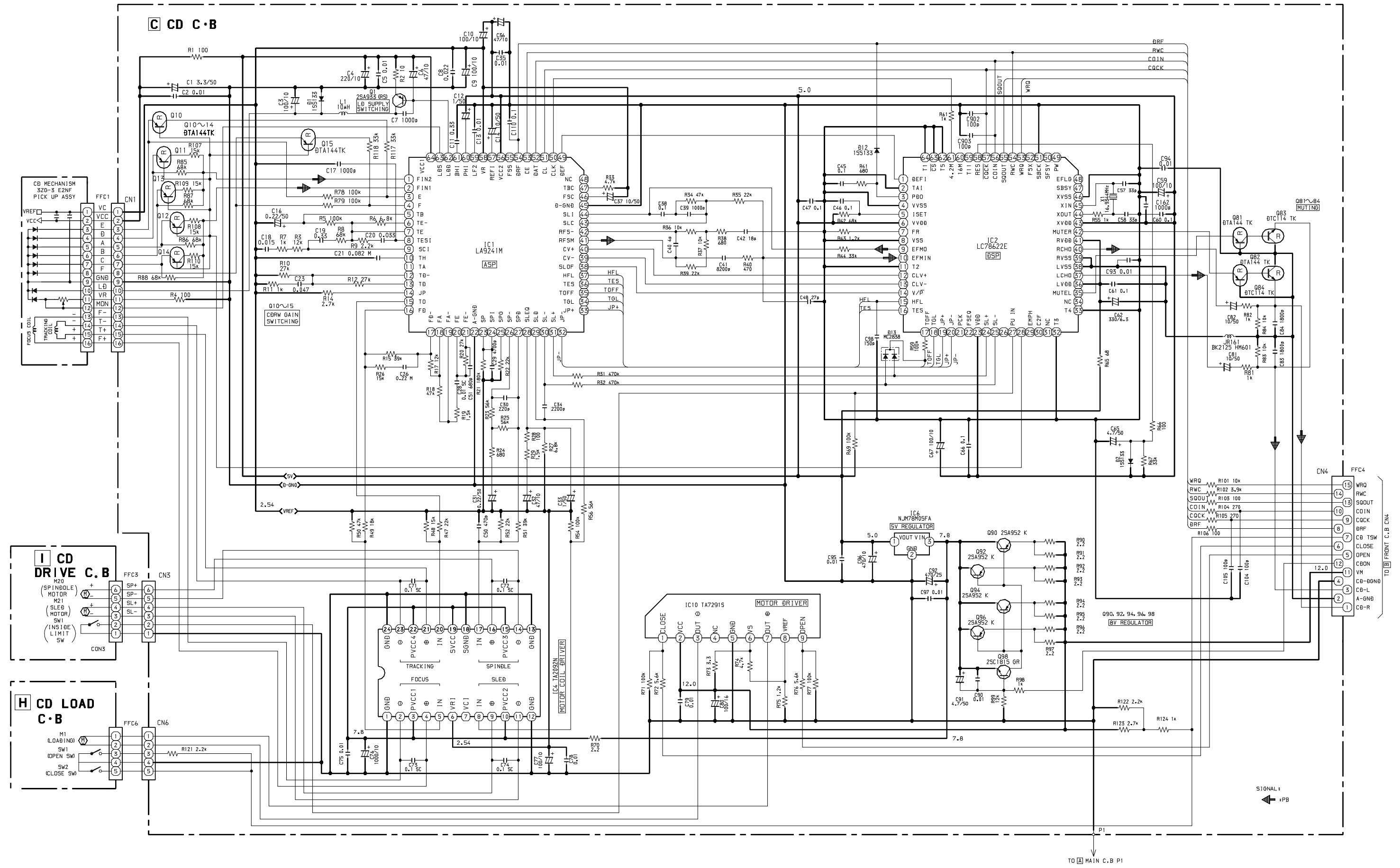

WIRING - 7 (PT: EZ,K)

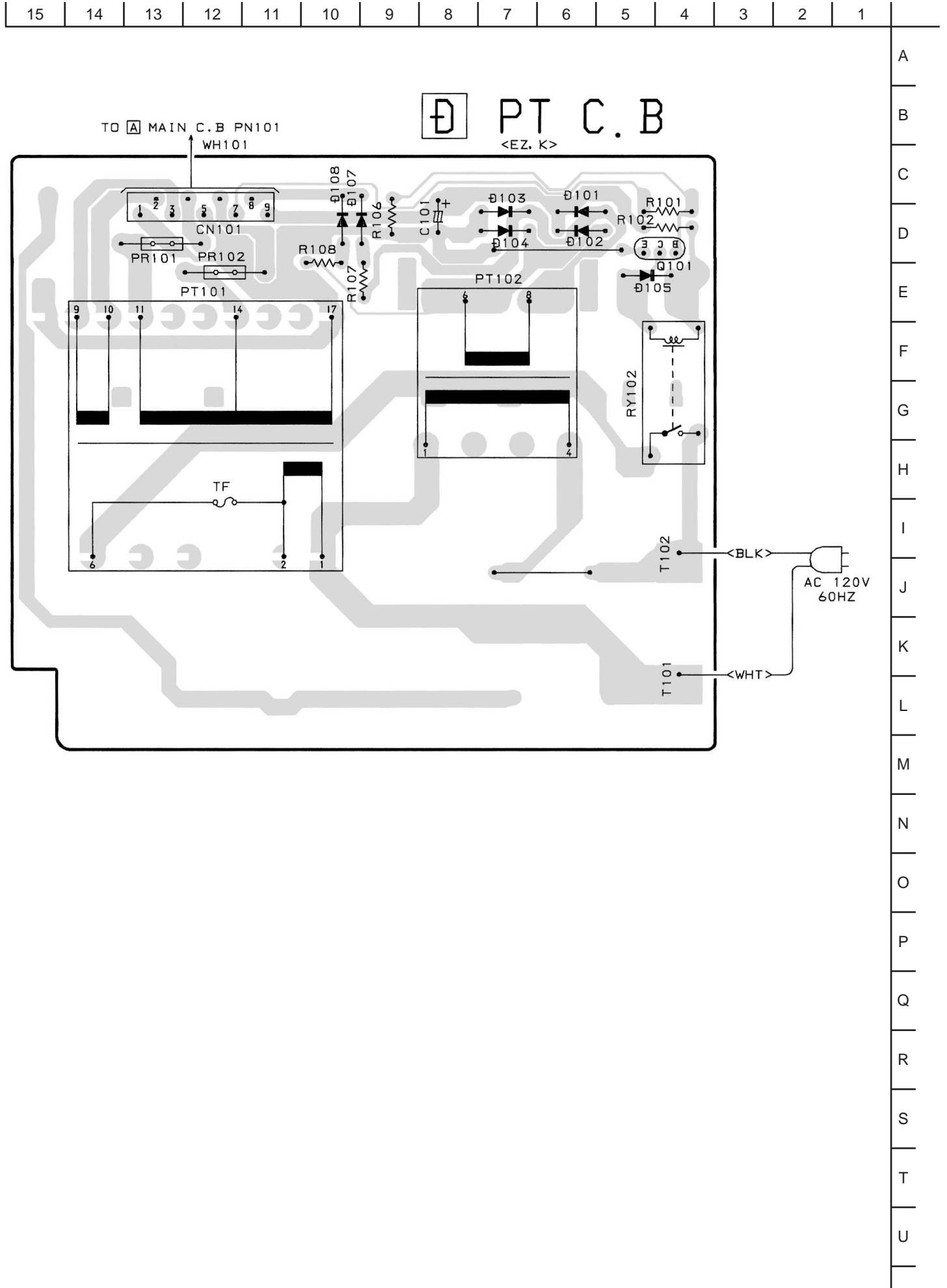

SCHEMATIC DIAGRAM - 7 (PT: EZ,K)

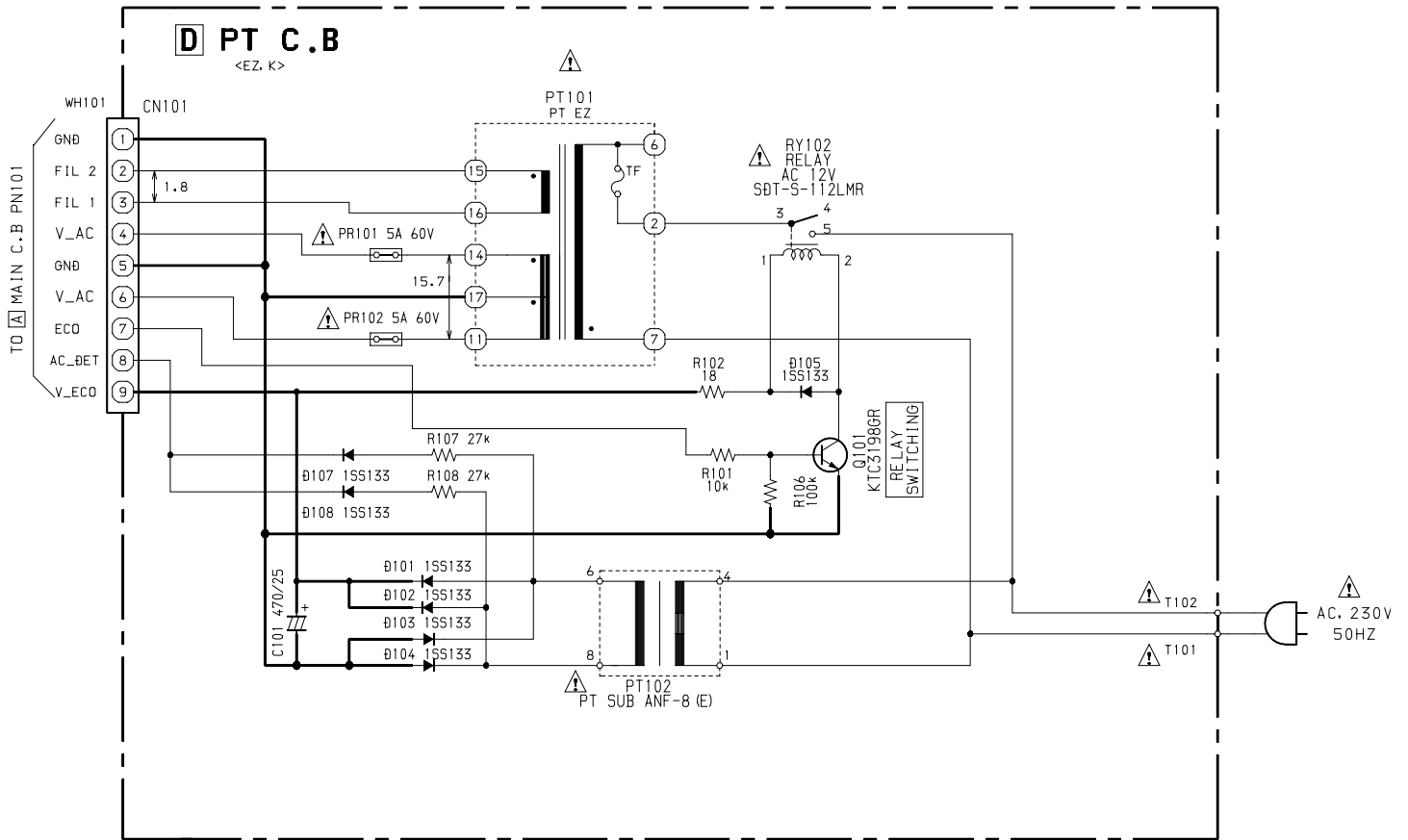



WIRING - 8 (PT: HR,HT)

15	14	13	12	11	10	9	8	7	6	5	4	3	2	1
----	----	----	----	----	----	---	---	---	---	---	---	---	---	---

A
B
C
D
E
F
G
H
I
J
K
L
M
N
O
P
Q
R
S
T
U

**PT C.B**  
<HR,HT>

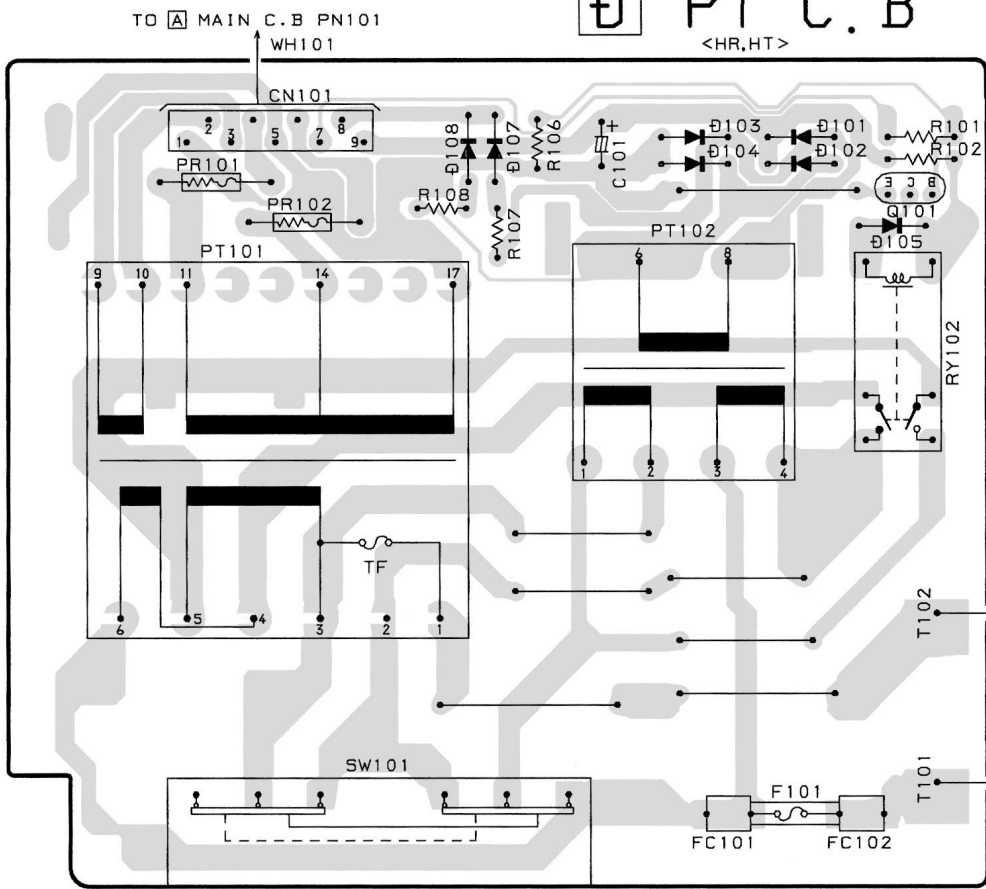

AC  
120/220V-240V  
SWITCHABLE 50/60HZ

SW101  
AC VOLTAGE  
220V-240V ↔ 120V

SCHEMATIC DIAGRAM - 8 (PT: HR,HT)

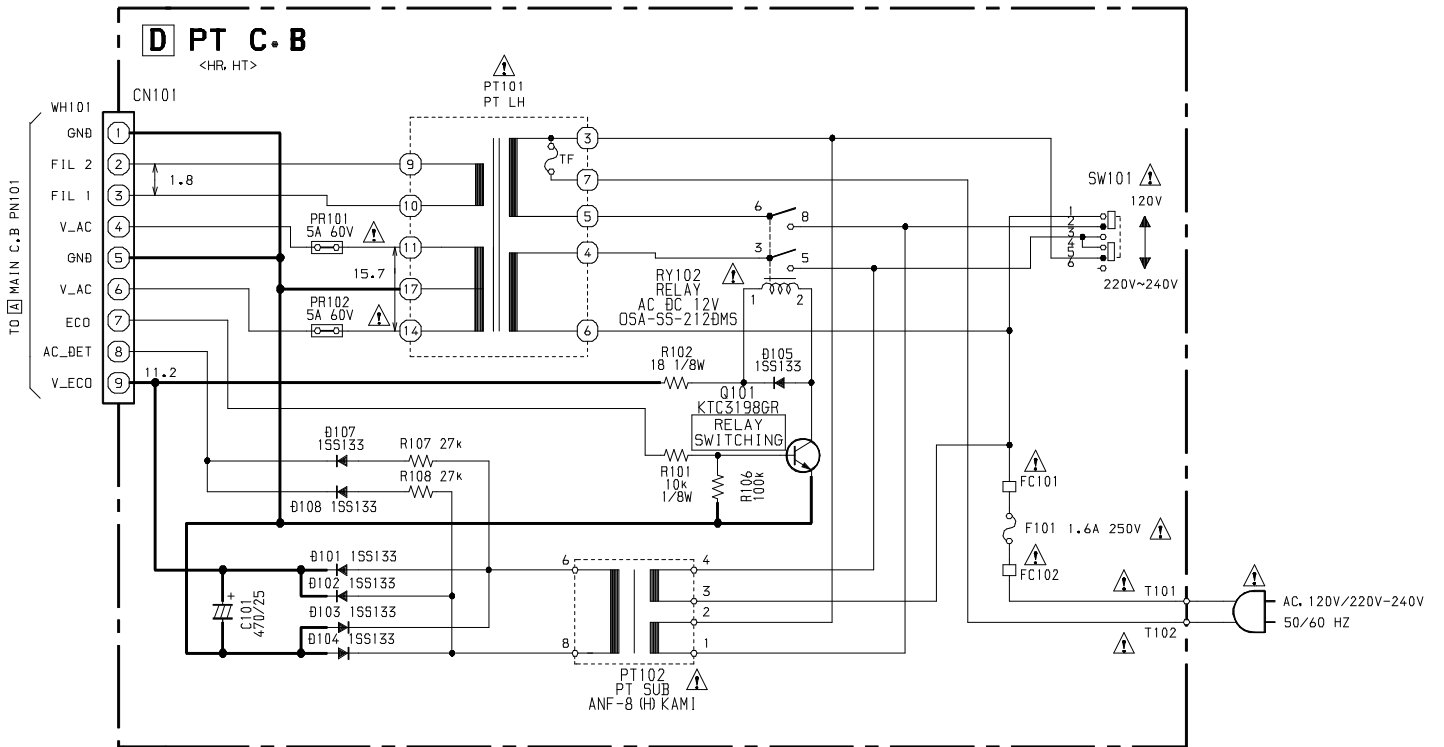

# IC BLOCK DIAGRAM

IC, M61509FP

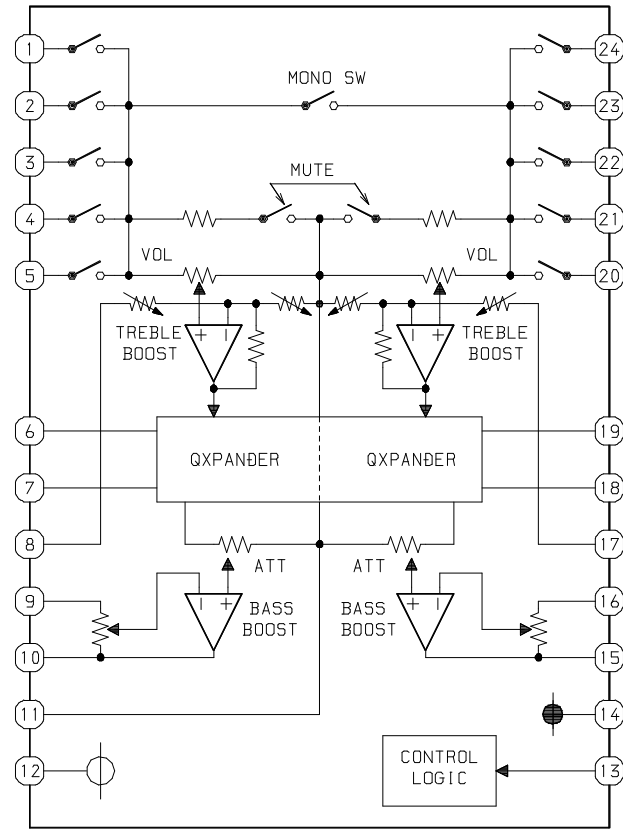

IC, TA2092N

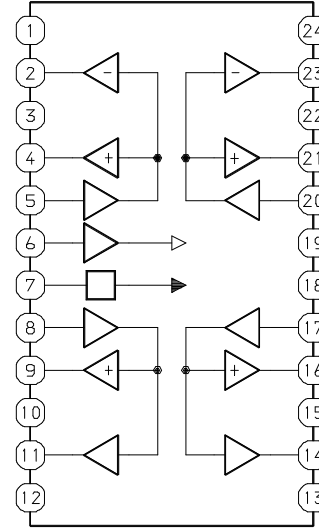

IC, TA7291S

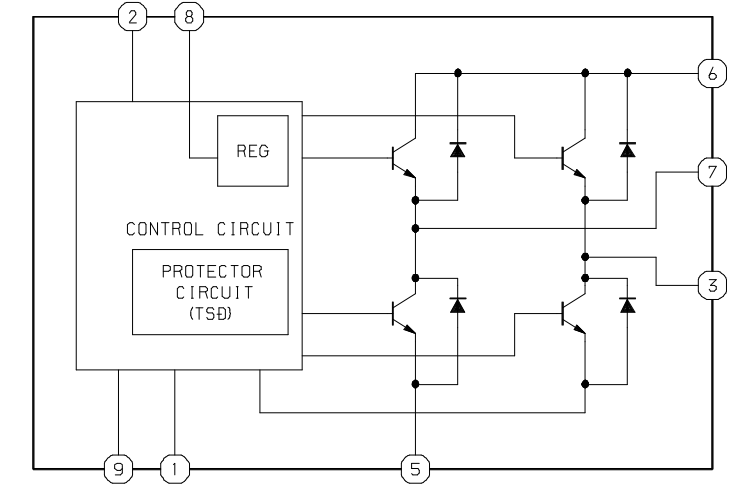

IC, LA1837NL

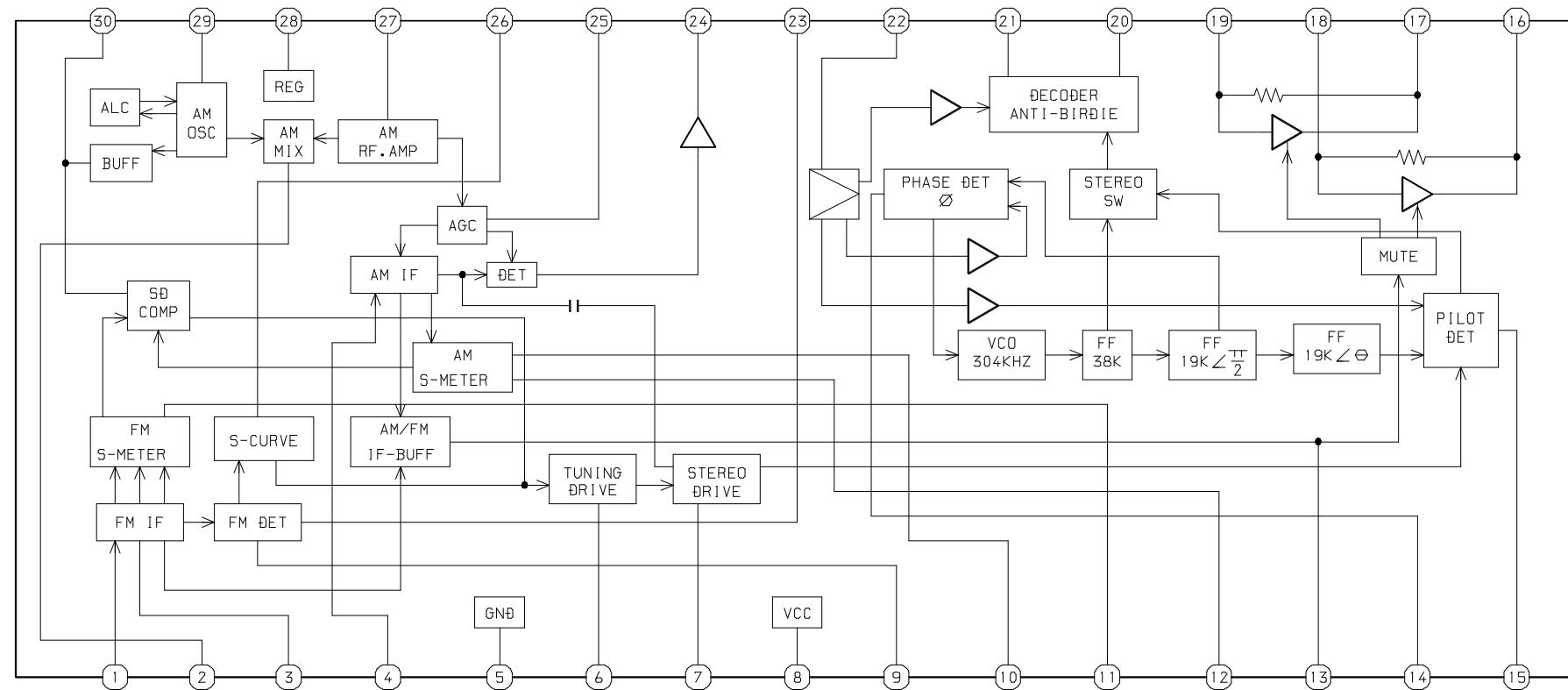

IC, BU1920FS

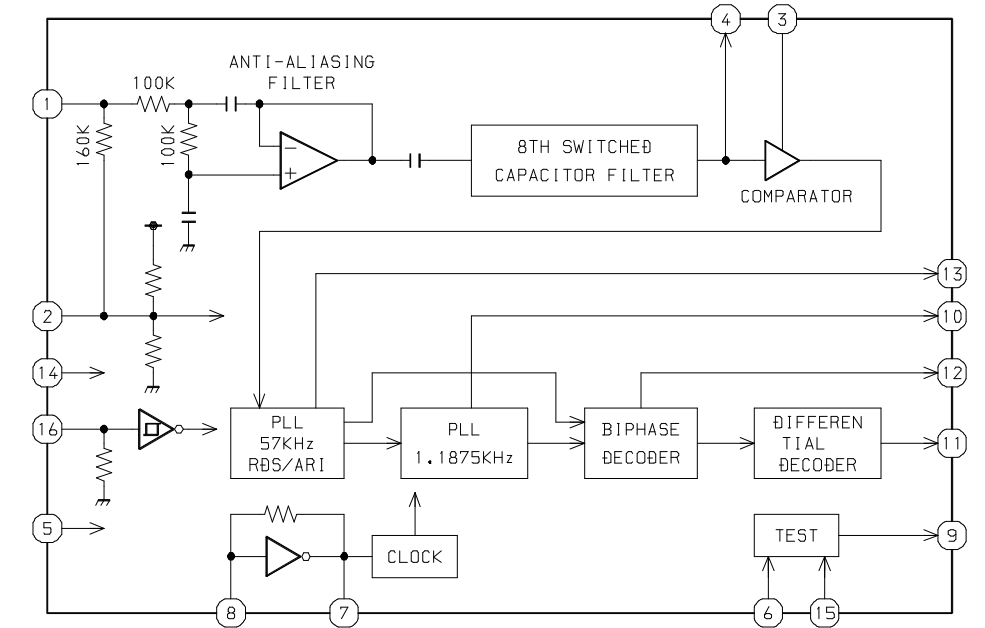

FL (11-BT-179GNK) GRID ASSIGNMENT AND ANODE CONNECTION  
 GRID ASSIGNMENT

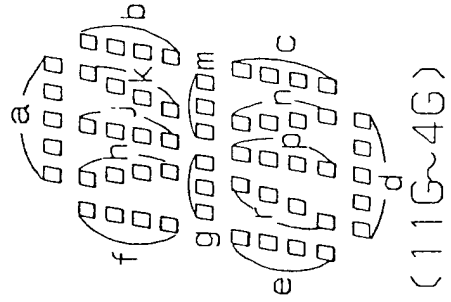
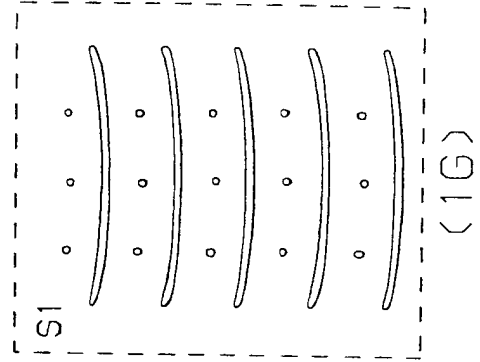
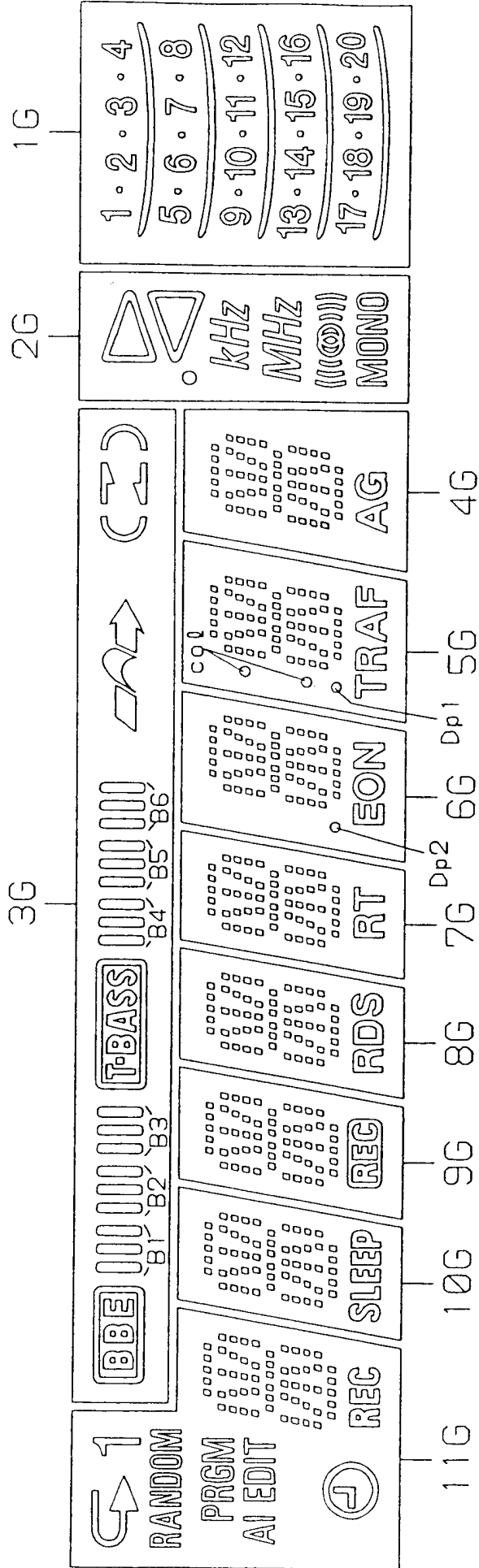

ANODE CONNECTION

	11G	10G	9G	8G	7G	6G	5G	4G	3G	2G	1G
P1	REC	SLEEP	REC	RDS	RT	EON	TRAF	AG	[BBE]	MONO	20
P2	d	d	d	d	d	d	d	d	B1	((((O)))	19
P3	n	n	n	n	n	n	n	n	B2	MHZ	18
P4	p	p	p	p	p	p	p	p	B3	KHZ	17
P5	r	r	r	r	r	r	r	r	[T-BASS]	○	16
P6	e	e	e	e	e	e	e	e *	B4	▽	15
P7	c	c	c	c	c	c	c	c	B5	△	14
P8	g	g	g	g	g	g	g	g	B6	-	13
P9	m	m	m	m	m	m	m	m	↔	-	12
P10	f	f	f	f	f	f	f	f	⌒	-	11
P11	b	b	b	b	b	b	b	b	⌒	-	10
P12	k	k	k	k	k	k	k	k	⌒	-	9
P13	j	j	j	j	j	j	j	j	-	-	8
P14	h	h	h	h	h	h	h	h	-	-	7
P15	a	a	a	a	a	a	a	a	-	-	6
P16	RANDOM	-	-	-	-	-	col	-	-	-	5
P17	Ⓢ	-	-	-	-	-	col	-	-	-	4
P18	↑	-	-	-	-	Dp2	Dp1	-	-	-	3
P19	PRGM	-	-	-	-	-	-	-	-	-	2
P20	AI	-	-	-	-	-	-	-	-	-	1
P21	EDIT	-	-	-	-	-	-	-	-	-	S1
P22	↶	-	-	-	-	-	-	-	-	-	-

IC DESCRIPTION  
IC, M38B57MCH-P239FP

Pin No.	Pin Name	I/O	Description
1	I-VOL	I	Rotary encider volume A/D input.
2	O-LED_AUX	O	Tuner functin LED ON/OFF output.Aux function LED ON/OFF output.
3	I-HOLD	I	System hold input A/D input.
4	I-SW_TP	I	Cassette detect switch A/D input.
5	I-KEY2	I	Key 2 A/D input.
6	I-KEY1	I	Key 1 A/D input.
7	O-LED_TU	O	Tuner functin LED ON/OFF output.
8	O-CLK_SHIFT	O	Micon clock shift output.
9	I-RMC	I	Remote-con data input.
10	I-RESET	I	Micon reset input.
11	XCOUT	O	32.768 kHz sub clock.
12	XCIN	I	
13	VSS	I	GND.
14	NC	I	Not connected.
15	NC	O	
16	VDD	I	Power supply.
17	O-SOL	O	Deck solenoid ON/OFF output.
18	O-REC/PB	O	Deck record/ playback select output.
19	O-TU_ON	O	Tuner mode on output.
20	O-BIAS	O	Rec 85 kHz oscillator ON/OFF output.
21	MUTE	O	Mute output.
22	I-WRQ	I	CD WRQ input.
23	O-POWER	O	Power ON/OFF control output.
24	O-LED_TP	O	Tape function LED ON/OFF output.
25	O-DATA	O	Common serial data output.
26	O-CLK	O	Common serial clock output.
27	O-KSCAN	O	Key-scan output.
28	VEE	I	-VFL.
29	O-PLL_CE	O	PLL chip enable output.
30	O-MOTOR	O	Deck motor ON/OFF control output.
31	RECMUTE	O	Record mute output.
32 ~ 42	O-G1 ~ G11	O	FL grid G1 ~ G11 output.
43 ~ 54	O-P1 ~ P12	O	FL port P1 ~ P12 output.
55	O-P13/LH	I/O	FL port P13 output/LH series detection.
56	O-P14	I/O	FL port P14 output.
57	O-P15/OIRT	I/O	FL port P15 output/OIRT diode detect input(Not used).
58	O-P16/I-RDS	I/O	FL port P16 output/RDS diode detect input.
59	O-P17/I-AMST	I/O	FL port P17 output/AM stereo diode detect input(Not used).
60	O-P18/I-LW	I/O	FL port P18 output/LW diode detect input.
61	O-P19/I-SW	I/O	FL port P19 output/SW diode detect input(Not used).
62	O-P20/I-AM10K	I/O	FL port P20 output/AM 10k setting diode detect input.

Pin No.	Pin Name	I/O	Description
63	O-P21/I-AS	I/O	FL port P21 output/Auto stop signal input.
64	O-P22/I-STOP	I/O	FL port P22 output/Deck stop signal input.
65	O-QSND	O	QSND chip enable output.
66	O- $\overline{\text{ECO}}$	O	Economical mode.
67	O-LED_CD	O	CD function LED ON/OFF output.
68	I-TM_BASE	I	Time base clock (8Hz) input.
69	O- $\overline{\text{CD\_ON}}$	O	CD ON/OFF control output.
70	O-CQCK	O	CD clock output.
71	O-RWC	I/O	CD control data output/RDS data input.
72	I- $\overline{\text{TU}}/\overline{\text{IFC}}/\overline{\text{SQOUT}}$	I/O	Tuner $\overline{\text{TUNE}}$ .IFC input/CD SQOUT input.
73	AVSS	I	A-GND.
74	VREF	I	Reference voltage input.
75	I- $\overline{\text{ST}}/\overline{\text{I-DRF}}$	I	Tuner stereo input/CD DRF input.
76	O- $\overline{\text{CD\_OPEN}}$	O	CD tray open output.
77	O- $\overline{\text{CD\_CLOSE}}$	O	CD tray close output.
78	I- $\overline{\text{CDTSW}}$	I	CD tray switch A/D input.
79	I-RDS_SIG/I- $\overline{\text{CD\_SIG}}$	I/O	RDS tuning level A/D input/CD music level input.
80	O-COIN	I	Command to CD DSP output.

Pin No.	Pin Name	I/O	Description
1	FIN2	I	Connects to the pickup's photo diode; adding this pin to pin FIN1 generates RF signal, and subtracting it generates FE signal.
2	FIN1	I	Connects to the pickup's photo diode.
3	E	I	Connects to the pickup's photo diode; subtracting this pin from pin F generates TE signal.
4	F	I	Connects to the pickup's photo diode.
5	TB	I	Input for DC component of TE signal.
6	TE-	I	Connects to the resistor between this pin and TE pin for setting the gain of TE signal.
7	TE	O	Output for TE signal.
8	TESI	I	Input for TES (Track Error Sense) comparator, TE signal is band-passed and inputted.
9	SCI	I	Input for shock detection.
10	TH	I	For setting tracking gain time constant.
11	TA	O	TA amplifier output pin.
12	TD-	I	For constructing tracking phase compensation constant between TD and VR pins.
13	TD	O	For setting tracking phase compensation.
14	JP	I	For setting the amplifier of tracking jump signal (kick pulse).
15	TO	O	Output for tracking control signal.
16	FD	O	Output for focusing control signal.
17	FD-	I	For constructing focusing phase compensation constant between FD and FA pins.
18	FA	O	For constructing focusing phase compensation constant between FD- and FA- pins.
19	FA-	I	For constructing focusing phase compensation constant between FA and FE pins.
20	FE	O	Output for FE signal.
21	FE-	I	Connects to the gain-setting resistor of FE signal between this pin and FE pin.
22	A-GND	-	GND for analog signals.
23	NC	-	Not connected.
24	SP	O	Single end output of CV+ and CV- pin input signal.
25	SPG	I	Connects to the gain-setting resistor during spindle 12cm mode.
26	SP-	I	Connects to spindle phase compensation constant together with SPD pin.
27	SPD	O	Output for spindle control signal.
28	SLEQ	I	Connects to sled phase compensation constant.
29	SLD	O	Output for sled control signal.
30	SL-	I	Input for sled-sending signal from microcontroller.
31	SL+	I	Input for sled-sending signal.
32	JP-	I	Input for tracking-jump signal from DSP.
33	JP+		
34	TGL	I	Input for tracking gain control signal from DSP; gain is low if TGL = "H".
35	TOFF	I	Input for tracking off control signal from DSP; off if TOFF = "H".
36	TES	O	Outputs TES signal to DSP.
37	HFL	O	HIGH FREQUENCY LEVEL; used to determine whether the main beam is on a pit or on a mirror.
38	SLOF	I	Input for sled servo off control.



Pin No.	Pin Name	I/O	Description
39	CV-	I	Input for CLV error signal from DSP.
40	CV+		
41	RFSM	O	Output for RF.
42	RFS-	O	For setting RF gain and 3T compensation constant together with RFSM.
43	SLC	O	SLICE LEVEL CONTROL; output for controlling the data slice level of DSP with RF waveform.
44	SLI	I	Input for controlling the data slice level of DSP.
45	D-GND	-	GND for digital system.
46	FSC	O	Output pin for focus search smoothing capacitor.
47	TBC	I	(Tracking Balance Control) EF balance variable range setting pin.
48	NC	-	Not connected.
49	DEF	O	Output for disk defect detection.
50	CLK	I	Standard clock input; DSP's 4.23MHz is inputted.
51	CL	I	Clock input for microcontroller command.
52	DAT	I	Data input for microcontroller command.
53	CE	I	Chip-enable input for microcontroller command.
54	DRF	O	Detect RF; output for RF level detection.
55	FSS	I	(Focus Search Mode) = search/+search against reference voltage switching pin. (Not used)
56	VCC2	-	VCC pin for servo and digital systems.
57	REFI	I	For connecting pass capacitor to reference voltage.
58	VR	O	Reference voltage output.
59	LF2	-	For setting disk defect-detection time constant.
60	PHI	-	Connects to capacitor for RF signal peak hold.
61	BHI	-	Connects to capacitor for RF signal bottom hold.
62	LDD	O	Output for APC circuit.
63	LDS	I	Input for APC circuit.
64	VCC1	-	VCC pin for RF system.

Pin No.	Pin Name	I/O	Description
1	DEFI	I	Defect detection signal (DEF) input.
2	TAI	I	Test input. A pull-down resistor is built in. Must be connected to 0V.
3	PDO	O	External VCO control phase comparator output.
4	VVSS	–	Internal VCO ground. Must be connected to 0V.
5	ISET	O	PDO output current adjustment resistor connection.
6	VVDD	–	Internal VCO power supply.
7	FR	–	VCO frequency range adjustment.
8	VSS	–	Digital system ground. Must be connected to 0V.
9	EFMO	O	Slice level control; EFM signal output.
10	EFMIN	I	Slice level control; EFM signal input.
11	T2	I	Test input. A pull-down resistor is built in. Must be connected to 0V.
12	CLV+	O	Disc motor control output. Three-value output is also possible when specified by microprocessor command.
13	CLV–		
14	V $\bar{P}$	O	Rough servo/phase control automatic switching monitor output. Outputs a high level during rough servo and a low level during phase control.
15	HFL	I	Track detection signal input. This is a Schmitt input.
16	TES	I	Tracking error signal input. This is a Schmitt input.
17	TOFF	O	Tracking off output.
18	TGL	O	Tracking gain switching output. Increase the gain when low.
19	JP+	O	Track jump output. Three-value output is also possible when specified by microprocessor command.
20	JP–		
21	PCK	O	EFM data playback clock monitor. Outputs 4.3218 MHz when the phase is locked. (Not used)
22	FSEQ	O	Synchronization signal detection output. Outputs a high level when the synchronization signal detected from the EFM signal and the internally generated synchronization signal agree. (Not used)
23	VDD	–	Digital system power supply.
24	SL+	O	Serial data command sled signal output terminal from microprocessor.
25	SL–		
26	NC	–	Not used.
27	PU IN	I	CD pickup inside limit switch.
28	NC	–	Not used.
29	EMPH	O	De-emphasis monitor pin. A high level indicates playback of a de-emphasis disk. (Not used)
30	C2F	O	C2 flag output. (Not used)
31	DOUT	O	Digital output (EIAJ format).
32	T3	I	Test input. A pull-down resistor is built in. Must be connected to 0V.
33	T4		
34	NC	–	Unused. Must be left open.
35	MUTEL	O	Left channel one-bit D/A converter mute output.
36	LVDD	–	Left channel one-bit D/A converter power supply.

Pin No.	Pin Name	I/O	Description
37	LCHO	O	Left channel one-bit D/A converter output.
38	LVSS	–	Left channel one-bit D/A converter ground. Must be connected to 0V.
39	RVSS	–	Right channel one-bit D/A converter ground. Must be connected to 0V.
40	RCHO	O	Right channel one-bit D/A converter output.
41	RVDD	–	Right channel one-bit D/A converter power supply.
42	MUTER	O	Right channel one-bit D/A converter mute output.
43	XVDD	–	Crystal oscillator power supply.
44	XOUT	O	Connections for a 16.934MHz crystal oscillator element.
45	XIN	I	
46	XVSS	–	Crystal oscillator ground. Must be connected to 0V.
47	SBSY	O	Subcode block synchronization signal output. (Not used)
48	EFLG	O	C1, C2 single and double error correction monitor pin. (Not used)
49	PW	O	Subcode P, Q, R, S, T, U, V and W output. (Not used)
50	SFSY	O	Subcode frame synchronization signal output. This signal falls when the subcode are in the standby state. (Not used)
51	SBCK	I	Subcode readout clock input. This is a Schmitt input. (Must be connected to 0V when unused)
52	FSX	O	Output for the 7.35 kHz synchronization signal divided from the crystal oscillator. (Not used)
53	WRQ	O	Subcode Q output standby output.
54	RWC	I	Readwrite control input. This is a Schmitt input.
55	SQOUT	O	Subcode Q output.
56	COIN	I	Command input from the control microprocessor.
57	$\overline{\text{CQCK}}$	I	Input for both the command input acquisition clock and the SQOUT pin subcode readout clock input. This is a Schmitt input.
58	$\overline{\text{RES}}$	I	Chip reset pin. This pin must be set low briefly after power is first applied.
59	T11	O	Test output. Leave open. (Normally outputs a low level). (Not used)
60	16M	O	16.9344 MHz output. (Not used)
61	4.2M	O	4.2336 MHz output.
62	T5	I	Test input. A pull-down resistor is built in. Must be connected to 0V.
63	$\overline{\text{CS}}$	I	Chip select input. A pull-down resistor is built in. Must be connected to 0V if not controlled.
64	T1	I	Test input. No pull-down resistor. Must be connected to 0V.

IC, LC72131D

Pin No.	Pin Name	I/O	Description																								
1	X-IN	I	A crystal oscillator (7.2MHz) is connected between these pins.																								
22	X-OUT	O																									
2	NC	-	Not used.																								
3	CE	I	To enable the IC. Active "H".																								
4	DI	I	Digital data input from CPU (M38B57MCH-P239FP) when relevant key is operated. Active "H".																								
5	CL	I	To clock in the data DI.																								
6	DO	O	Digital data output to CPU (M38B57MCH-P239FP).																								
7	T-BASE	O	Outputs a reference clock signal (8Hz) for the clock.																								
8	$\overline{\text{MONO}} / \text{BEAT}$	O	Outputs "H" when MONO / BEAT is switched.																								
9	$\overline{\text{FM}} / \overline{\text{SW}}$	O	Output "L" or "H" as follows: <table border="1" style="margin-left: 20px;"> <thead> <tr> <th colspan="2">2 BAND</th> <th colspan="3">3 BAND</th> <th colspan="3">3 BAND</th> </tr> <tr> <th>AM</th> <th>FM</th> <th>LW</th> <th>MW</th> <th>FM</th> <th>MW</th> <th>SW</th> <th>FM</th> </tr> </thead> <tbody> <tr> <td>H</td> <td>L</td> <td>H</td> <td>H</td> <td>L</td> <td>H</td> <td>L</td> <td>L</td> </tr> </tbody> </table>	2 BAND		3 BAND			3 BAND			AM	FM	LW	MW	FM	MW	SW	FM	H	L	H	H	L	H	L	L
2 BAND		3 BAND			3 BAND																						
AM	FM	LW	MW	FM	MW	SW	FM																				
H	L	H	H	L	H	L	L																				
10	$\overline{\text{MW}} / \text{SW}$	O	Outputs "L" or "H" as follows: <table border="1" style="margin-left: 20px;"> <thead> <tr> <th colspan="2">2 BAND</th> <th colspan="3">3 BAND</th> <th colspan="3">3 BAND</th> </tr> <tr> <th>AM</th> <th>FM</th> <th>LW</th> <th>MW</th> <th>FM</th> <th>MW</th> <th>SW</th> <th>FM</th> </tr> </thead> <tbody> <tr> <td>L</td> <td>L</td> <td>H</td> <td>L</td> <td>L</td> <td>L</td> <td>H</td> <td>L</td> </tr> </tbody> </table>	2 BAND		3 BAND			3 BAND			AM	FM	LW	MW	FM	MW	SW	FM	L	L	H	L	L	L	H	L
2 BAND		3 BAND			3 BAND																						
AM	FM	LW	MW	FM	MW	SW	FM																				
L	L	H	L	L	L	H	L																				
11	IF-MUTE	O	To control internal counter.																								
12	IF-IN	I	General purpose counter input.																								
13	$\overline{\text{TUNE}}$	I	Receives "L" when station is tuned.																								
14	NC	-	Not used.																								
15	AM-IN	I	Receives the AM local oscillator frequency signal.																								
16	FM-IN	I	Receives the FM local oscillator frequency signal.																								
17	VDD	-	Supply power to IC (+5V).																								
18	PD	O	PLL charge pump output.																								
19	A-IN	I	The MOS transistor for PLL active low pass filter.																								
20	A-OUT	O																									
21	VSS	-	Ground.																								

## ADJUSTMENT

### < TUNER SECTION >(EZ,K)

1. Clock Frequency Check  
Settings : • Test point : TP2 (CLK)  
Method : Set to MW 1602kHz and check that the test point is 2052kHz  $\pm$  45Hz.
2. MW VT Check  
Settings : • Test point : TP1 (VT)  
Method : Set to MW 1602kHz and check that the test point is less than 8.0V. Then set to MW 531kHz and check that the test point is more than 0.6V.
3. MW Tracking Adjustment  
Settings : • Test point : TP8 (Lch), TP9 (Rch)  
• Adjustment location : L981 (1/3)  
Method : Set to MW 999kHz and adjust L981 (1/3) so that the test point becomes maximum.
4. LW VT Adjustment  
Settings : • Test point : TP1 (VT)  
• Adjustment location : L942  
Method : Set to LW 144kHz and adjust L942 so that the test point becomes 1.3V  $\pm$  0.05V.  
Then set to LW 290kHz and check that the test point is less than 8.0V.
5. LW Tracking Adjustment  
Settings : • Test point : TP8 (Lch), TP9 (Rch)  
• Adjustment location :  
L941 ..... 144kHz  
TC942 ..... 290kHz  
Method : Set up TC942 to center before adjustment.  
The level at 144kHz is adjusted to MAX by L941. Then the level at 290kHz is adjusted to MAX by TC942.
6. AM IF Adjustment  
Settings : • Test point : TP8 (Lch), TP9 (Rch)  
• Adjustment location :  
L772 450kHz
7. FM VT Check  
Settings : • Test point : TP1 (VT)  
Method : Set to FM 108.0MHz and check that the test point is less than 8.0V. Then set to FM 87.5MHz and check that the test point is more than 0.5V.
8. FM Tracking Check  
Settings : • Test point : TP8 (Lch), TP9 (Rch)  
Method : Set to FM 98.0MHz and check that the test point is less than 13dB $\mu$ V.
9. DC Balance / Mono Distortion Adjustment  
Settings : • Test point : TP3,TP4 (DC balance)  
• Adjustment location : L771  
• Input level : 60dB $\mu$ V  
Method : Set to FM 98.0MHz and adjust L771 so that the voltage between TP3 and TP4 becomes 0V  $\pm$  0.04V.  
Next, check that the distortion is less than 1.3%.
10. Output Level Check  
<MW>  
Settings : • Test point : TP8 (Lch), TP9 (Rch)  
• Input level : 74dB $\mu$ V  
Method : Set to MW 999kHz and check that the test point is 130mV  $\pm$  3dB.  
  
<FM>  
Settings : • Test point : TP8 (Lch), TP9 (Rch)  
• Input level : 60dB $\mu$ V  
Method : Set to FM 98.0MHz and check that the test point is 520mV  $\pm$  3dB.
11. FM Separation Check  
Settings : • Test point : TP8 (Lch), TP9 (Rch)  
• Input level : 60dB $\mu$ V  
Method : Set to FM 98.0MHz and check that the test point is more than 25dB.

< TUNER SECTION >(HR,HT)

1. Clock Frequency Check  
Settings : • Test point : TP2 (CLK)  
Method : Set to AM 1602kHz and check that the test point is 2052kHz ± 45Hz.
2. AM VT Check  
Settings : • Test point : TP1(VT)  
Method : Set to AM 1602kHz and check that the test point is less than 8.0V. Then set to AM 531kHz and check that the test point is more than 0.6V.
3. AM Tracking Adjustment  
Settings : • Test point : TP6(Lch), TP7(Rch)  
• Adjustment location :  
L981(1/3) ..... 999kHz  
Method : Adjust L981 (1/3) so that the output becomes maximum.
4. FM VT Check  
Settings : • Test point : TP1 (VT)  
Method : Set to FM 108.0MHz and check that the test point is less than 8.0V.  
Set to FM 87.5MHz and check that the test point is more than 0.5V.
5. FM Tracking Check  
Settings : • Test point : TP6(Lch), TP7(Rch)  
Method : Set to FM 98.0MHz and check that the test point is less than 9.0dBµV.
6. AM IF Adjustment  
Settings : • Test point : TP6(Lch), TP7(Rch)  
• Adjustment location :  
L772 ..... 450kHz  
Method : Adjust L772 so that the output becomes maximum.
7. DC Balance / Mono Distortion Adjustment  
Settings : • Test point : TP3, TP4 (DC Balance)  
TP6(Lch), TP7(Rch) (Distortion)  
• Adjustment location : L771  
• Input level : 60dBµV  
Method : Set to FM 98.0MHz and adjust L771 so that the voltage between TP3 and TP4 becomes 0V ± 0.04V.  
Next, check that the distortion is less than 1.3%

< DECK SECTION >

1. Tape Speed Adjustment  
Settings : • Test tape : TTA-100  
• Test point : SP-OUT 2V  
• Adjustment location : SFR1  
Method : Play back the test tape and adjust SFR1 for 3000Hz ± 5Hz (FWD) and FWD PLAY speed ± 45Hz (REV).
2. Head Azimuth Adjustment  
Settings : • Test tape : TTA-300  
• Test point : SP-OUT 2V  
• Adjustment location : Head azimuth adjustment screw  
Method : Play back the 8kHz signal of the test tape and adjust screw so that the output becomes maximum. Next, perform on each FWD PLAY and REV PLAY mode.
3. PB Frequency Response Check  
Settings : • Test tape : TTA-320  
• Test point : SP-OUT 2V  
Method : Play back the 315Hz and 10kHz signals of the test tape and check that the 10kHz signal with respect to that of the 315Hz signal is 0dB ± 3dB.
4. REC/PB Frequency Response Check  
Settings : • Test tape : TTA-602  
• Test point : SP-OUT 2V  
Method : Input a -20VU signal to the AUX terminal. Record the 1kHz and 10kHz signals on the test tape and play back them. Check that the difference between the record level and the play back level at 1kHz and 10kHz signal is 0dB to ± 3dB.



# MECHANICAL PARTS LIST 1 / 1

REF. NO.	PART NO.	KANRI NO.	DESCRIPTION	REF. NO.	PART NO.	KANRI NO.	DESCRIPTION
1	82-ZM1-264-010		LVR,EJECT R	19	8A-CL9-069-010		KEY, DEMO
2	88-CL4-215-010		CUSH, FOOT FR	20	82-NF5-229-010		PLATE, LOCK
3	8A-CL9-046-010		BOX, CASS U<150K>	21	86-NF9-224-010		SPR-C, LOCK
3	8A-CL9-047-010		BOX, CASS H<130HR, 130HT>	22	87-NF4-217-110		HLDR, LOCK 2
3	8A-CL9-048-010		BOX, CASS EZ<151EZ>	23	87-NF8-220-010		DMPR, 150
3	8A-CL9-049-010		BOX, CASS M152<152EZ>	24	88-CL4-220-010		SPR-T, CASS
3	8A-CLK-049-010		BOX, CASS EZ100<100EZ>	25	8A-CL9-095-010		PLATE, FL
3	8A-CLK-048-010		BOX, CASS EZ121<121EZ>	26	82-NF7-210-110		GUIDE, FL (*)
3	8A-CLK-046-010		BOX, CASS U<120K>	27	8A-CL9-202-010		HLDR, CD
4	8A-CL9-052-010		WINDOW, CASS<100EZ, 120K, 121EZ, 152EZ>	28	87-099-811-010		PLUG, ADPTR CONV(K)<120K, 150K>
4	8A-CL9-054-010		WINDOW, CASS<130HR, 130HT, 150K, 151EZ>	29	87-A80-148-010		AC CORD ASSY, E BLK<EXCEPT K>
5	8A-CL9-080-010		KNOB, RTRY VOLUME	29	87-A80-157-010		AC CORD ASSY, E BLK C<K>
6	8A-CL9-053-010		WINDOW, DISPLAY EZ<121EZ, 151EZ>	30	8A-CL9-026-010		CABI, TOP
6	8A-CL9-051-010		WINDOW, DISPLAY U<120K, 100EZ>	31	8A-CL9-013-010		PANEL, REAR EZS<151EZ.
6	8A-CL9-055-010		WINDOW, DISP SK R<152EZ>	31	8A-CL9-016-010		PANEL, REAR KSC<150K>
6	8A-CL9-056-010		WINDOW, DISP SG<130HR, 130HT, 150K>	31	8A-CL9-017-010		PANEL, REAR EZ152<152EZ>
7	8A-CL9-077-010		RING, VOLUME	31	8A-CL9-018-010		PANEL, REAR HTSF<130HT>
8	8A-CL9-088-010		LENS, REMOTE-C<100EZ, 120K, 121EZ>	31	8A-CL9-019-010		PANEL, REAR HRSP<130HR>
8	8A-CL9-088-110		LENS, REMOTE-C<130HR, 130HT, 150K, 151EZ, 152EZ>	31	8A-CLK-016-010		PANEL, REAR EZ100<100EZ>
9	8A-CL9-030-010		PANEL, TRAY ASSY<100EZ, 120K, 121EZ, 152EZ>	31	8A-CLK-015-010		PANEL, REAR EZ121<121EZ>
9	8A-CL9-033-010		PANEL, TRAY SG A<130HR, 130HT, 150K, 151EZ>	31	8A-CLK-013-010		PANEL, REAR KSC<120K>
10	8A-CL9-062-010		KEY, POWER	32	8A-CL9-211-010		HLDR, TRANS<100EZ, 120K, 121EZ>
11	8A-CL9-002-010		CABI, FRONT EZ<121EZ>	32	8A-CL9-211-110		HLDR, TRANS<130HR, 130HT, 150K, 151, 152EZ>
11	8A-CL9-001-010		CABI, FRONT U<120K, 100EZ>	33	88-CL4-216-010		CUSH, FOOT REAR
11	8A-CL9-002-110		CABI, FRONT SI-MB R<151EZ>	A	87-067-703-010		TAPPING SCREW, BVT2+3-10
11	8A-CL9-003-010		CABI, FRONT SI-MB<130HR>	B	87-571-032-410		VIT+2-3
11	8A-CL9-003-210		CABI, FRONT SI-MB<130HT>	C	87-581-170-410		UIT+4-8
11	8A-CL9-004-110		CABI, FRONT SI-MS R<152EZ>	D	87-B10-231-010		QT1+3-12 SILVER CR
12	8A-CL9-063-010		KEY, FUNC ASSY	E	87-B10-230-010		BVT2+3-10 W/O SLOT SILVER CR
13	8A-CL9-206-010		GUIDE, LED-FUNC	F	87-B10-250-010		BVT2+3-12 W/O SLOT CR SILVER
14	8A-CL9-085-010		REFLECTOR, LED-FUNC				
15	8A-CL9-066-010		KEY, CONTROL				
16	8A-CL9-065-010		KEY, OPEN				
17	8A-CL9-067-010		KEY, Q-SOUND				
18	8A-CL9-068-010		KEY, JOG MODE				

## COLOR NAME TABLE

Basic color symbol	Color	Basic color symbol	Color	Basic color symbol	Color
B	Black	C	Cream	D	Orange
G	Green	H	Gray	L	Blue
LT	Transparent Blue	N	Gold	P	Pink
R	Red	S	Silver	ST	Titan Silver
T	Brown	V	Violet	W	White
WT	Transparent White	Y	Yellow	YT	Transparent Yellow
LM	Metallic Blue	LL	Light Blue	GT	Transparent Green
LD	Dark Blue	DT	Transparent Orange	GM	Metallic Green
YM	Metallic Yellow	DM	Metallic Orange	PT	Transparent Pink



TAPE MECHANISM EXPLODED VIEW 1 / 1

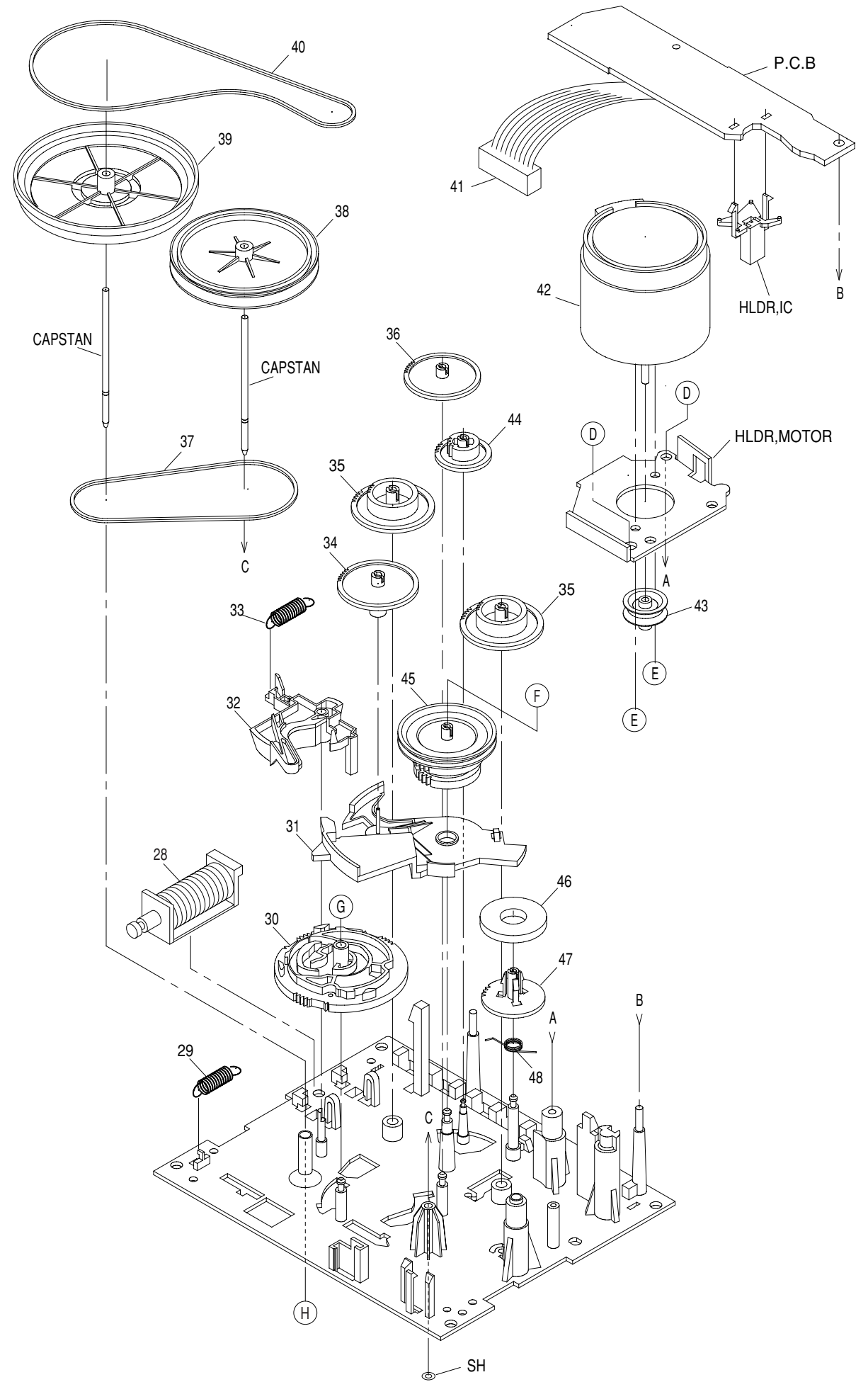
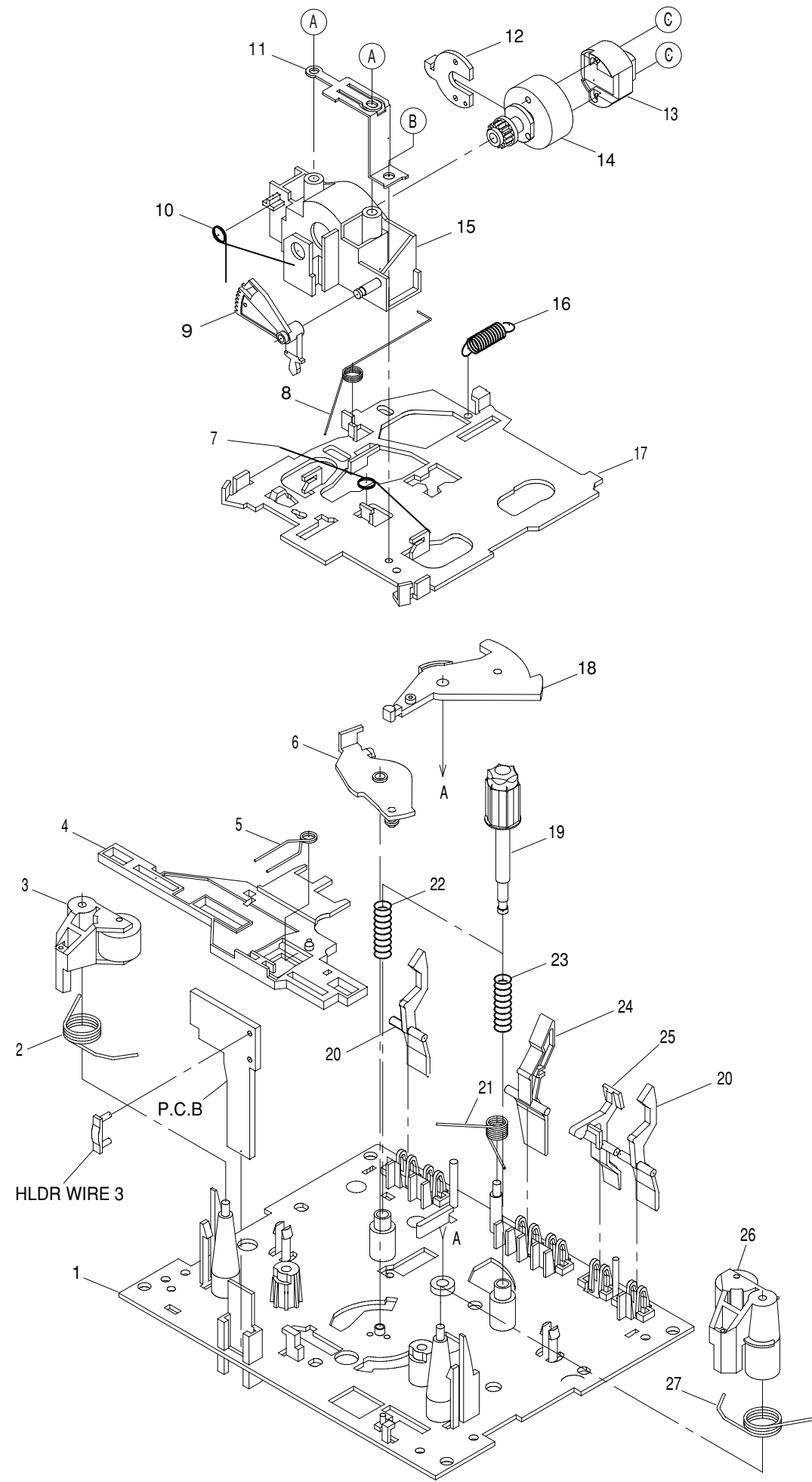

# TAPE MECHANISM PARTS LIST 1 / 1

REF. NO.	PART NO.	KANRI NO.	DESCRIPTION	REF. NO.	PART NO.	KANRI NO.	DESCRIPTION
1	82-ZM1-327-310		CHAS ASSY, RM	31	82-ZM1-224-410		LVR, FR
2	82-ZM1-258-210		SPR-T, PINCH L	32	82-ZM1-227-310		LVR, TRIG
3	82-ZM1-341-210		LVR ASSY, PINCH L2	33	82-ZM1-305-210		SPR-E, TRIG 2
4	82-ZM1-266-310		LVR, DIR	34	82-ZM1-225-210		GEAR, FR
5	82-ZM1-214-010		SPR-T, DIR	35	82-ZM1-216-510		GEAR, REEL
6	82-ZM1-333-210		PLATE, LINK2	36	82-ZM1-226-010		GEAR, REW
7	82-ZM1-269-210		SPR-T, BRG	37	82-ZM1-338-110		BELT, FR 4
8	82-ZM1-219-110		SPR-T, LINK	38	82-ZM1-348-110		FLY-WHL, L W
9	82-ZM1-210-110		GEAR, H T	39	82-ZM1-349-110		FLY-WHL, R W
10	82-ZM3-353-010		SPR-T, HEAD 2	40	82-ZM1-354-010		BELT, SBU MAIN2 EPDM
11	82-ZM1-298-010		SPR-P EARTH	41	87-009-352-010		CONN, 9P PH H
12	82-ZM1-314-110		PLATE, HEAD	42	87-045-347-010		MOT, SHU2L 70
13	87-046-399-110		HEAD, RPH YK56R-BS411	43	82-ZM1-247-210		PULLEY, MOTOR
14	82-ZM1-208-310		HLD, HEAD	44	82-ZM1-223-010		GEAR, PLAY
15	82-ZM1-207-910		GUIDE, TAPE	45	82-ZM3-333-310		SLIP DISK ASSY 2
16	82-ZM1-218-010		SPR-E, HB	46	82-ZM3-616-010		RING MAGNET 4
17	82-ZM1-206-910		CHAS, HEAD	47	82-ZM1-220-210		GEAR, IDLER
18	82-ZM1-222-310		LVR, PLAY (*)	48	82-ZM1-322-010		SPR-T, FR 60
19	82-ZM1-217-410		REEL TABLE	A	82-ZM1-283-310		S-SCREW, AZIMUTH
20	82-ZM1-240-110		LVR, REC (*)	B	82-ZM1-315-010		S-SCREW GUIDE TAPE
21	82-ZM1-257-010		SPR-T, CAS	C	80-ZM6-207-010		V+1.6-7
22	82-ZM1-285-410		SPR-C, BT L	D	87-741-073-410		UT2+2.6-6 GLD
23	82-ZM1-244-510		SPR-C, BT	E	87-251-070-410		U+2.6-3
24	82-ZM1-242-010		LVR, CAS	F	82-ZM3-334-010		PW 2.16-6-0.4
25	82-ZM1-243-010		LVR, STOP	G	87-B10-008-010		W-P, 2.08-8-0.4-SLIP
26	82-ZM1-344-210		LVR ASSY, PINCH R2	H	80-ZM6-243-010		SH 1.75-3.6-0.5 SLT
27	82-ZM1-259-210		SPR-T, PINCH R				
28	82-ZM3-627-010		SOL ASSY, 27 SO				
29	82-ZM1-255-310		SPR-E, LVR DIR				
30	82-ZM1-221-310		GEAR, CAM (*)				

# CD MECHANISM EXPLODED VIEW 1 / 2

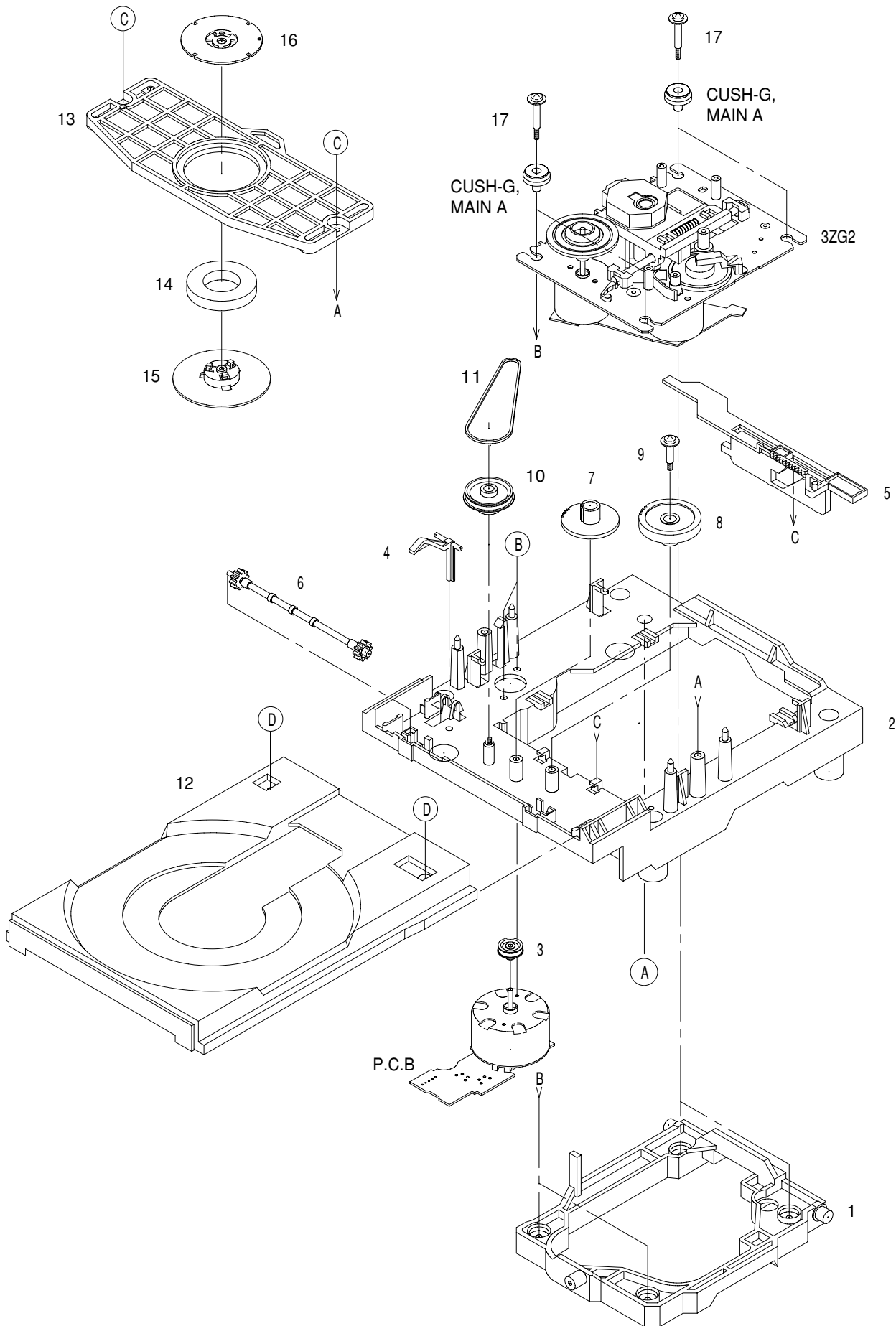

# CD MECHANISM PARTS LIST 1 / 2

REF. NO.	PART NO.	KANRI NO.	DESCRIPTION
1	83-ZG3-224-310		HLDR, M2
2	83-ZG3-228-610		CHAS, L6
3	83-ZG3-208-010		PULLEY, MOTOR
4	83-ZG3-213-010		LVR, SW
5	83-ZG3-209-610		CAM, SLIDE
6	83-ZG3-207-010		GEAR, TRAY
7	83-ZG3-204-210		GEAR, C
8	83-ZG3-205-010		GEAR, D
9	83-ZG3-217-010		S-SCREW, GEAR D
10	83-ZG3-220-210		GEAR, PULLEY 2
11	83-ZG3-214-010		BELT, L
12	83-ZG3-229-410		TRAY, CD 2
13	83-ZG3-210-110		HLDR, CHUCK
14	83-ZG3-602-010		RING, MAG
15	83-ZG3-212-010		CAP, DISC
16	83-ZG3-211-010		PLATE, DISC
17	81-ZG1-254-010		S-SCEW, MECH HLDR
A	87-067-945-110		VFT2+3-12 (F10)
B	87-251-071-110		U+2.6-4
C	87-512-074-210		VFT2+2.6-8
D	87-352-075-210		VT2+2.6-10

## CD MECHANISM EXPLODED VIEW 2 / 2

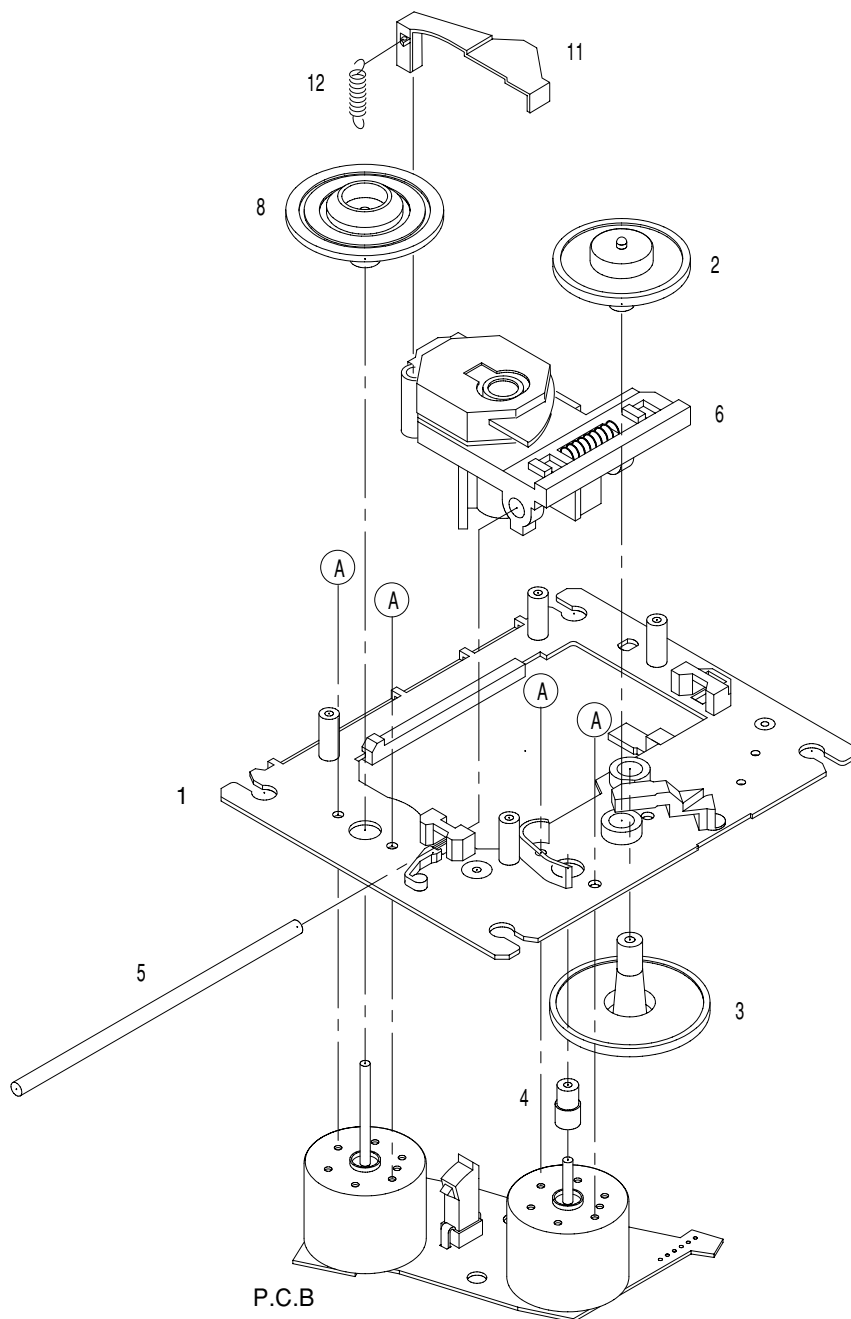

## CD MECHANISM PARTS LIST 2 / 2

REF. NO.	PART NO.	KANRI NO.	DESCRIPTION
1	83-ZG2-243-210		CHAS ASSY, SHT
2	83-ZG2-235-010		GEAR, A3
3	83-ZG2-205-210		GEAR, B
4	83-ZG2-236-010		GEAR MOTOR 3
5	83-ZG2-253-010		SHAFT, SLIDE 5
6	87-A90-836-010		PICKUP, KSS-213F
8	83-ZG2-227-210		TURN TABLE, C1
11	83-ZG2-245-410		LEVER, SHUTTER
12	83-ZG2-250-110		SPR-E, SHT 2
A	87-261-032-210		SCREW V+2-3

**アイワ株式会社** 〒110-8710 東京都台東区池之端1-2-11 ☎03(3827)3111 (代表)  
**AIWA CO.,LTD.** 2-11, IKENOHATA 1-CHOME, TAITO-KU, TOKYO 110, JAPAN TEL:03 (3827) 3111