



SERVICE MANUAL

COMPACT DISC STEREO SYSTEM

BASIC TAPE MECHANISM : AZM-6 AR1NC
BASIC CD MECHANISM : DA11T3C

SYSTEM	CD-CASSEIVER	SPEAKER
XR-M101	CX-SLM101	SX-SLM101
XR-M131	CX-SLM131	SX-SLM131

SPECIFICATIONS

(101LH, 131U MODEL)

MAIN UNIT

TUNER

FM tuning range	87.5 MHz to 108 MHz
FM usable sensitivity (IHF)	13.2 dBf
FM antenna terminals	75 ohms (unbalanced)
AM tuning range	530 kHz to 1710 kHz (10 kHz step) 531 kHz to 1602 kHz (9 kHz step)
AM usable sensitivity	350 μ V/m
AM antenna	Loop antenna

AMPLIFIER

Power output	101LH : 4 W + 4 W (4 ohms, T.H.D. 1% 1 kHz) 5 W + 5 W (4 ohms, T.H.D. 10% 1 kHz) 131U : 5.5 W + 5.5 W (50 Hz - 20 kHz, THD less than 1%, 4 ohms) 7 W + 7 W (1 kHz, THD less than 10%, 4 ohms)
Total harmonic distortion	0.2 % (2 W, 1 kHz, 4 ohms)
Input	AUX: 500 mV
Outputs	SPEAKERS: 4 ohms or more PHONES: 32 ohms or more

CASSETTE DECK

Track format	4 tracks, 2 channels stereo
Frequency response	50 Hz – 15000 Hz
Recording system	AC bias
Heads	Recording/playback \times 1, erase \times 1

CD PLAYER

Laser	Semiconductor laser ($\lambda = 780$ nm)
D/A converter	1 bit dual
Signal-to-noise ratio	85 dB (1 kHz, 0 dB)
Harmonic distortion	Unmeasurable (1 kHz, 0 dB)

GENERAL

Power requirements	101LH : 120/220-240 V AC switchable, 50/60 Hz 131U : 120V AC, 60 Hz
Power consumption	101LH : 30 W 131U : 26 W
Dimensions (W \times H \times D)	101LH : 160 \times 237 \times 207 mm 131U : 160 \times 237 \times 206 mm (6 $\frac{3}{8}$ \times 9 $\frac{3}{8}$ \times 8 $\frac{1}{8}$ in.)
Weight	101LH : 2.7 kg 131U : 2.9 kg (6 lbs 7 oz)

SPEAKER SYSTEM

Speakers	100 mm cone type
Impedance	4 ohms
Dimensions (W \times H \times D)	140 \times 232.5 \times 191.5 mm (5 $\frac{5}{8}$ \times 9 $\frac{1}{4}$ \times 7 $\frac{5}{8}$ in.)
Weight	1.1 kg (2 lbs 8 oz)

- Design and specifications are subject to change without notice.

(101K, EZ, 131EZ MODEL)

MAIN UNIT

TUNER

FM tuning range	87.5 MHz to 108 MHz
FM usable sensitivity (IHF)	16.8 dBf
FM antenna terminal	75 ohms (unbalanced)
MW tuning range	531 kHz to 1602 kHz (9 kHz step) 530 kHz to 1710 kHz (10 kHz step)
MW usable sensitivity	350 μ V/m
LW tuning range	144 kHz to 290 kHz
LW usable sensitivity	1400 μ V/m
MW/LW antenna	Loop antenna

AMPLIFIER

Power output	Rated: 4 W + 4 W (4 ohms, T.H.D. 1%, 1kHz/ DIN 45500) Reference: 5 W + 5 W (4 ohms, T.H.D. 10%, 1kHz/DIN 45324) DIN MUSIC POWER 7 W + 7 W
Input	AUX: 500 mV
Outputs	SPEAKERS: 4 ohms or more PHONES: 32 ohms or more

CASSETTE DECK

Track format	4 tracks, 2 channels stereo
Frequency response	50 Hz – 15000 Hz
Recording system	AC bias
Heads	Recording/playback \times 1, erase \times 1

CD PLAYER

Laser	Semiconductor laser ($\lambda = 780$ nm)
D/A converter	1 bit dual
Signal-to-noise ratio	85 dB (1 kHz, 0 dB)
Harmonic distortion	Unmeasurable (1 kHz, 0 dB)

GENERAL



Power requirements	230 V AC, 50 Hz
Power consumption	30 W
Dimensions (W \times H \times D)	160 \times 237 \times 209 mm
Weight	131EZ : 2.9 kg 101k, EZ : 2.7 kg

SPEAKER SYSTEM

Speakers	100 mm cone type
Impedance	4 ohms
Dimensions (W \times H \times D)	140 \times 232.5 \times 191.5 mm
Weight	1.1 kg

- Design and specifications are subject to change without notice.

ACCESSORIES/PACKAGE LIST-1/1

REF. NO	PART NO.	KANRI NO.	DESCRIPTION
1	8B-CLB-906-110		1IB,EZ (9L)B<131EZSC>
1	8B-CLL-906-010		1IB,EZ (9L)B<101EZSC>
1	8B-CLB-905-110		1IB,K (E)B<101KSC>
1	8B-CLA-902-110		1IB,LH (ESP)B<101LHSC>
1	8B-CLB-903-110		1IB,U (ESF)B<131USC>
2	8A-CLB-961-210		2RC UNIT,RC-AAT11 <EXCEPT 131USC,101LHSC>
2	8A-CLB-961-110		2RC UNIT,RC-AAT11<131USC,101LHSC>
3	87-A90-030-010		3ANT,LOOP AM-NC C
4	87-043-115-010		4ANT,FEEDER FM<131USC,101LHSC>
4	87-A90-118-010		4ANT,WIRE FM (Z)<EXCEPT 131USC,101LHSC>
	5	87-099-726-010	5PLUG,ADPTR CONV(K)<101KSC>
	5	87-A91-017-010	5PLUG,CONVERSION JT-0476<101LHSC>

PROTECTION OF EYES FROM LASER BEAM DURING SERVICING

This set employs laser. Therefore, be sure to follow carefully the instructions below when servicing.

WARNING!

WHEN SERVICING, DO NOT APPROACH THE LASER EXIT WITH THE EYE TOO CLOSELY. IN CASE IT IS NECESSARY TO CONFIRM LASER BEAM EMISSION. BE SURE TO OBSERVE FROM A DISTANCE OF MORE THAN 30cm FROM THE SURFACE OF THE OBJECTIVE LENS ON THE OPTICAL PICK-UP BLOCK.

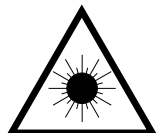

- Caution: Invisible laser radiation when open and interlocks defeated avoid exposure to beam.
- Advarsel: Usynlig laserstråling ved åbning, når sikkerhedsafbrydere er ude af funktion. Undgå udsættelse for stråling.

VAROITUS!

Laiteen Käyttäminen muulla kuin tässä käyttöohjeessa mainituilla tavalla saattaa altistaa käyttäjän turvallisuusluokan 1 ylittävälle näkymättömälle lasersäteilylle.

WARNING!

Om apparaten används på annat sätt än vad som specificeras i denna bruksanvisning, kan användaren utsättas för osynlig laserstrålning, som överskrider gränsen för laserklass 1.

CAUTION

Use of controls or adjustments or performance of procedures other than those specified herein may result in hazardous radiation exposure.

ATTENTION

L'utilisation de commandes, réglages ou procédures autres que ceux spécifiés peut entraîner une dangereuse exposition aux radiations.

ADVARSEL!

Usynlig laserstråling ved åbning, når sikkerhedsafbrydere er ude af funktion. Undgå udsættelse for stråling.

This Compact Disc player is classified as a CLASS 1 LASER product.

The CLASS 1 LASER PRODUCT label is located on the rear exterior.

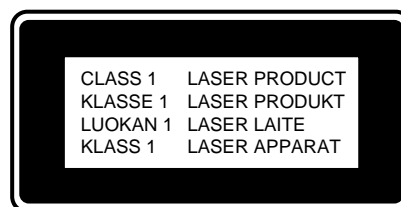

Precaution to replace Optical block (SF-P101NR)

Body or clothes electrostatic potential could ruin laser diode in the optical block. Be sure ground body and workbench, and use care the clothes do not touch the diode.

- 1) After the connection, remove solder shown in the right figure.

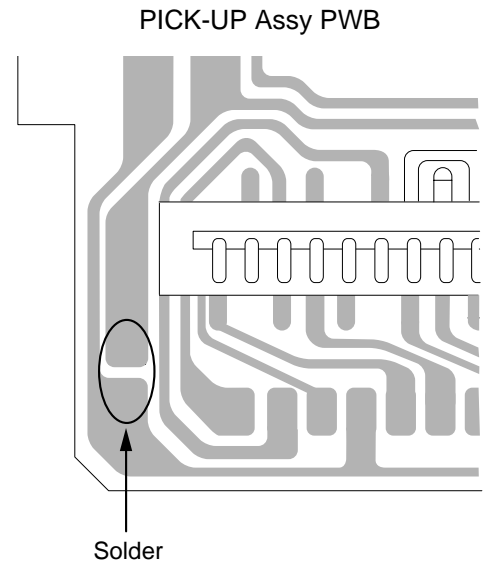

ELECTRICAL MAIN PARTS LIST-1/6

REF. NO	PART NO.	KANRI NO.	DESCRIPTION	REF. NO	PART NO.	KANRI NO.	DESCRIPTION
IC				C106	87-010-192-080		C-CAP, S 0.022-50 Z F C2012
	87-020-454-010	IC, DN6851		C107	87-010-192-080		C-CAP, S 0.022-50 Z F C2012
	87-A20-440-040	C-IC, BU1920FS<131EZ>		C108	87-010-192-080		C-CAP, S 0.022-50 Z F C2012
	87-A20-446-010	C-IC, LA9241ML		C109	87-010-192-080		C-CAP, S 0.022-50 Z F C2012
	87-A21-319-010	C-IC, LC78622NE		C110	87-A12-310-080		C-CAP, U 0.01UF-50V K X7R
	87-A21-520-040	C-IC, M61509FP<101LH, 131U>		C111	87-010-453-010		CAP, E 4700-25 M SME<101LH>
	87-A21-443-040	C-IC, M62495AFP<101K, 101EZ, 131EZ>		C111	87-016-440-090		CAP, E 4700-35V SME<131U>
	87-A21-145-040	IC BA4560F For 2 CH OPE. AMP		C112	87-012-140-080		C-CAP, S 470P-50 J CH
	87-A21-928-010	IC LC72131D (Z) [SANYO]		C113	87-010-408-080		Cap. 47uF M ELEC. 50V P=5mm
	87-A20-913-010	IC, LA1837NL		C114	87-A12-310-080		C-CAP, U 0.01UF-50V K X7R
	87-A21-756-010	IC, LA4629		C115	87-010-112-080		CAP, E 100-16 M 11L SME
	87-A21-093-010	IC, LA6541D		C116	87-010-101-080		CAP, E 220-16 M SME
	8B-CLA-610-010	IC, LC867248A-5T90		C117	87-A12-310-080		C-CAP, U 0.01UF-50V K X7R
	87-A21-245-010	IC, RPM6938-V4		C118	87-010-263-080		CAP, E 100-10 M 11L SME
				C119	87-018-047-080		Cap. 0.01UF N CER. 16V Y TYPE
TRANSISTOR				C120	87-010-545-080		CAP, E 0.22-50 M 11L SME
	89-505-434-540	C-FET, 2SK543 (4/5)<101K, 101EZ, 131EZ>		C121	87-010-401-080		CAP, E 1-50 M 11L SME
	87-A30-257-080	C-TR 2SD1306E (200mw) [CDIL] <101K, 101EZ, 131EZ>		C122	87-010-401-080		CAP, E 1-50 M 11L SME
	87-A30-287-040	C-TR DTC114TK (0.2W) [ROHM]		C125	87-010-401-080		CAP, E 1-50 M 11L SME
	89-327-143-080	C-TR, 2SC27140		C126	87-010-401-080		CAP, E 1-50 M 11L SME
	87-A30-076-080	C-TR, 2SC3052F<131EZ>		C129	87-A10-831-090		Elect Cap. 1000uF +/-20% 25V
	87-A30-432-040	C-TR, DTC124XK (0.2W)		C130	87-A10-831-090		Elect Cap. 1000uF +/-20% 25V
	86-NFZ-664-080	C-TR, DTC143TK		C131	87-A12-310-080		C-CAP, U 0.01UF-50V K X7R
	87-026-210-040	C-TR, DTC144EK (200MW)		C132	87-A12-310-080		C-CAP, U 0.01UF-50V K X7R
	87-A30-074-080	C-TR, RT1P 141C<101K, 101EZ, 131EZ>		C133	87-A12-310-080		C-CAP, U 0.01UF-50V K X7R
	87-A30-072-080	C-TR, RT1P 144C		C134	87-A12-310-080		C-CAP, U 0.01UF-50V K X7R
	87-A30-091-080	FET, 2SJ460		C135	87-010-405-080		CAP, E 10-50 M 11L SME
	87-A30-492-080	TR 2SC5343G [AUK] [AIWA]		C136	87-010-404-080		CAP, E 4.7-50 M 11L SME
	89-112-965-080	TR, 2SA1296GR		C139	87-010-401-080		CAP, E 1-50 M 11L SME
	87-A30-515-080	TR, 2SA19790/Y		C140	87-010-401-080		CAP, E 1-50 M 11L SME
	87-A30-151-080	TR, 2SA1993F		C141	87-010-405-080		CAP, E 10-50 M 11L SME
	89-109-332-380	TR, 2SA933S-S (300mw)		C142	87-010-405-080		CAP, E 10-50 M 11L SME
	89-109-521-080	TR, 2SA952K		C143	87-010-405-080		CAP, E 10-50 M 11L SME
	S1-911-240-000	TR, 2SB1240		C144	87-010-405-080		CAP, E 10-50 M 11L SME
	89-320-011-080	TR, 2SC2001K		C145	87-010-404-080		CAP, E 4.7-50 M 11L SME
	89-333-317-080	TR, 2SC3331TU		C146	87-010-404-080		CAP, E 4.7-50 M 11L SME
	87-A30-185-010	TR, 2SD1381F		C147	87-A12-310-080		C-CAP, U 0.01UF-50V K X7R
	89-418-580-080	TR, 2SD1858TV<101LH, 131U>		C148	87-A12-310-080		C-CAP, U 0.01UF-50V K X7R
	87-026-291-080	TR, DTC124XS (0.3W) AI		C151	87-010-545-080		CAP, E 0.22-50 M 11L SME
	87-026-218-080	TR, DTC144ES		C152	87-010-545-080		CAP, E 0.22-50 M 11L SME
	87-026-313-080	TR, DTC343TS		C153	87-010-545-080		CAP, E 0.22-50 M 11L SME
	87-A30-476-010	TR, KTA1046Y		C154	87-010-545-080		CAP, E 0.22-50 M 11L SME
	87-026-610-080	TR, KTC3198GR		C158	87-010-263-080		CAP, E 100-10 M 11L SME
	87-CD7-603-080	TR, S8050		C159	87-010-182-080		C-CAP, S 2200P-50 K B C2012
	87-A30-196-080	Transistor 2SC4115SR(400MW) <101K, 101EZ, 131EZ>		C160	87-A12-310-080		C-CAP, U 0.01UF-50V K X7R
				C161	87-010-263-080		CAP, E 100-10 M 11L SME
				C162	87-A12-310-080		C-CAP, U 0.01UF-50V K X7R
				C166	87-012-368-080		C-CAP, S 0.1UF-50V K X7R
				C169	87-A12-310-080		C-CAP, U 0.01UF-50V K X7R
				C170	87-010-112-080		CAP, E 100-16 M 11L SME
DIODE				C171	87-010-384-080		Elect. Cap. 100UF +/-20% 25V Pi
	87-020-027-080	C-DIODE, 1SS184		C173	87-018-131-080		CAP, TC U 1000P-50 K B UP050
	87-A40-270-080	C-DIODE, MC2838<101K, 101EZ, 131EZ>		C177	87-010-248-080		CAP, E 220-10 M 11L SME
	87-A40-393-090	Diode 1N5402-BD54 [RECTRON]		C303	87-010-180-080		C-CAP, S 1500P-50 K B C2012
	87-020-465-080	DIODE, 1SS133		C304	87-010-180-080		C-CAP, S 1500P-50 K B C2012
	87-070-335-080	Zener Diode MTZJ8.2B, 26mm TAPE		C305	87-010-263-080		CAP, E 100-10 M 11L SME
	87-A40-442-080	ZENER DIODE MTZJ9.1A 1/2W. AI		C306	87-010-263-080		CAP, E 100-10 M 11L SME
	87-070-334-080	ZENER, MTZJ10B		C307	87-010-830-080		C-CAP, U 0.068uF-16V K X7R
	87-070-136-080	ZENER, MTZJ5.1B		C308	87-010-830-080		C-CAP, U 0.068uF-16V K X7R
	87-A40-234-080	ZENER, MTZJ5.6A<101K, 101EZ, 131EZ>		C309	87-010-188-080		C-CAP, S 6800P-50 K B C2012
	87-017-932-080	ZENER, MTZJ6.2B		C310	87-010-188-080		C-CAP, S 6800P-50 K B C2012
	87-A40-290-080	Vari-Cap. Diode 3KV1590 [MI TY]		C312	87-010-401-080		CAP, E 1-50 M 11L SME
MAIN C. B<101LH, 131U>				C313	87-010-401-080		CAP, E 1-50 M 11L SME
C101	87-A12-310-080	C-CAP, U 0.01UF-50V K X7R		C314	87-010-401-080		CAP, E 1-50 M 11L SME
C102	87-A12-310-080	C-CAP, U 0.01UF-50V K X7R		C315	87-010-401-080		CAP, E 1-50 M 11L SME
C103	87-A12-310-080	C-CAP, U 0.01UF-50V K X7R		C316	87-010-182-080		C-CAP, S 2200P-50 K B C2012
C104	87-010-404-080	CAP, E 4.7-50 M 11L SME		C317	87-010-182-080		C-CAP, S 2200P-50 K B C2012
C105	87-010-403-080	CAP, E 3.3-50 M 11L SME		C318	87-A12-364-080		Cap. 0.01 uF K Mylar 100V AI
				C319	87-A12-364-080		Cap. 0.01 uF K Mylar 100V AI
				C320	87-A10-295-080		Cap. 0.01UF J Mylar 50V AI

ELECTRICAL MAIN PARTS LIST-2/6

REF. NO	PART NO.	KANRI NO.	DESCRIPTION	REF. NO	PART NO.	KANRI NO.	DESCRIPTION
C321	87-A10-295-080		Cap. 0.01UF J Mylar 50V AI	C789	87-012-275-080		C-CAP,U 1200P-50 K B GRM
C322	87-010-321-080		C-CAP,S 82P-50 J CH	C790	87-012-275-080		C-CAP,U 1200P-50 K B GRM
C323	87-010-321-080		C-CAP,S 82P-50 J CH	C791	87-010-405-080		CAP,E 10-50 M 11L SME
C324	87-010-112-080		CAP,E 100-16 M 11L SME	C793	87-012-273-080		C-CAP,U 820P-50 K B
C325	87-010-112-080		CAP,E 100-16 M 11L SME	C794	87-010-406-080		CAP,E 22-50 M 11L SME
C326	87-010-192-080		C-CAP,S 0.022-50 Z F C2012	C795	87-010-596-080		CAP,S 0.047-16
C327	87-010-183-080		C-CAP,S 2700P-50 K B GRM	C796	87-010-403-080		CAP,E 3.3-50 M 11L SME
C328	87-010-183-080		C-CAP,S 2700P-50 K B GRM	C797	87-012-278-080		C-CAP,U 2200P-50 K B
C329	87-010-183-080		C-CAP,S 2700P-50 K B GRM	C798	87-012-278-080		C-CAP,U 2200P-50 K B
C331	87-010-382-080		CAP,E 22-25 M 11L SME	C799	87-010-596-080		CAP,S 0.047-16
C332	87-010-187-080		C-CAP,S 5600P-50 K B	C812	87-A12-310-080		C-CAP, U 0.01UF-50V K X7R
C333	87-010-178-080		C-CAP,S 1000P-50 K B C2012	C820	87-010-260-080		CAP,E 47-25 M 11L SME
C335	87-012-158-080		C-CAP,S 390P-50 J CH GRM	C821	87-A12-310-080		C-CAP, U 0.01UF-50V K X7R
C336	87-012-158-080		C-CAP,S 390P-50 J CH GRM	C822	87-A12-310-080		C-CAP, U 0.01UF-50V K X7R
C337	87-010-192-080		C-CAP,S 0.022-50 Z F C2012	C823	87-A12-310-080		C-CAP, U 0.01UF-50V K X7R
C338	87-012-140-080		C-CAP,S 470P-50 J CH	C828	87-010-196-080		C-CAP,S 0.1-25 Z F C2012
C339	87-010-405-080		CAP,E 10-50 M 11L SME	C829	87-010-196-080		C-CAP,S 0.1-25 Z F C2012
C340	87-010-405-080		CAP,E 10-50 M 11L SME	C959	87-010-196-080		C-CAP,S 0.1-25 Z F C2012
C341	87-010-318-080		C-CAP,S 47P-50 J CH GRM	C960	87-010-196-080		C-CAP,S 0.1-25 Z F C2012
C342	87-010-318-080		C-CAP,S 47P-50 J CH GRM	C961	87-012-166-080		C-CAP, U 4 P-50V C COG
C345	87-012-158-080		C-CAP, U 680P-50V K X7R	C963	87-010-196-080		C-CAP,S 0.1-25 Z F C2012
C346	87-012-158-080		C-CAP, U 680P-50V K X7R	CF801	87-008-261-010		FLTR,CF SFE10.7MA5
C350	87-010-374-080		CAP,E 47-10 M 11L SME	CF802	87-008-261-010		FLTR,CF SFE10.7MA5
C351	87-010-234-040		Cap. 47UF M Elec. 16V P=5mm	CN101	88-NF9-658-010		CONN,30P BLK TYK-B(P)
C354	87-012-268-080		C-CAP, U 330P-50V J COG	CN301	87-099-832-010		CONN,8P V S2M-8W
C355	87-012-268-080		C-CAP, U 330P-50V J COG	F101	87-035-457-010		FUSE,3.15A 250V T 218<101LH>
C701	87-010-381-080		CAP,E 330-16 M SME	F101	87-035-457-010		UL 239 T 3A 250V DIA: 5 x 20mm<131U>
C702	87-010-404-080		CAP,E 4.7-50 M 11L SME	FC101	87-033-213-080		FUSE CLAMP,PFC5000
C703	87-A12-310-080		C-CAP, U 0.01UF-50V K X7R	FC102	87-033-213-080		FUSE CLAMP,PFC5000
C704	87-A12-310-080		C-CAP, U 0.01UF-50V K X7R	FFE801	A8-82A-192-070		82A-1 FEUNC (FM:12V) [AIWA]
C709	87-012-195-080		C-CAP,U 100P-50 J CH	J101	87-099-715-010		RCA Jack (HSP-242V-05)
C711	87-010-263-080		CAP,E 100-10 M 11L SME	J102	87-A60-754-010		Speaker Terminal 4 pins Push t
C712	87-010-196-080		C-CAP,S 0.1-25 Z F C2012	J103	87-A60-420-010		Stereo Headphone Jack (DC:34V/
C714	87-A12-310-080		C-CAP, U 0.01UF-50V K X7R	J801	87-A60-202-010		TERMINAL,ANT 4P MSP-154V-02
C717	87-A12-310-080		C-CAP, U 0.01UF-50V K X7R	JW718	87-A50-079-080		Fixed Inductor 22uH CECSS +/-
C719	87-A12-310-080		C-CAP, U 0.01UF-50V K X7R	L101	87-005-366-010		COIL,1UH K
C720	87-012-195-080		C-CAP,U 100P-50 J CH	L102	87-005-366-010		COIL,1UH K
C721	87-012-176-080		C-CAP,U 15P-50 J CH	L104	87-005-676-080		COIL,2.2UH K LF5.0S
C722	87-012-176-080		C-CAP,U 15P-50 J CH	L301	87-007-342-010		COIL OSC 85K BIAS
C723	87-012-274-080		C-CAP,U 1000P-50 K B	L771	87-A50-266-010		COIL FM DET-N (TOK)
C725	87-012-274-080		C-CAP,U 1000P-50 K B	L772	87-A90-733-010		FLTR,PCFAZH-450 (TOK)
C727	87-010-196-080		C-CAP,S 0.1-25 Z F C2012	L773	S6-046-410-000		AM ANT COIL PIN : 3-1:15T
C728	87-010-248-080		CAP,E 220-10 M 11L SME	L774	S6-033-110-000		AM OSC COIL PIN: 1-2:62T
C729	87-012-274-080		C-CAP, U 1000P-50 K B	L781	87-005-676-080		COIL,2.2UH K LF5.0S
C731	87-A12-310-080		C-CAP, U 0.01UF-50V K X7R	PR100	87-A91-940-080		PROTECTOR,2.5A 20P 60V<101LH>
C756	87-A12-310-080		C-CAP, U 0.01UF-50V K X7R	PR100	87-A91-965-080		FUSE,2.5A 125V F 20N<131U>
C757	87-012-188-080		C-CAP, U 47P-50 J CH	R118	SR-F82-000-25N		RES,FUSE 82-1/2W J
C758	87-012-167-080		C-CAP,U 5P-50 C CH	WH101	87-099-043-010		CONN 2P EH<101LH>
C763	87-010-596-080		CAP,S 0.047-16	WH101	87-A90-458-010		HLDL,WIRE 2.5-3P<131U>
C764	87-012-337-080		C-CAP,U 56P-50 J CH GRM	X721	87-A70-061-010		VIB,XTAL 4.500MHZ CSA-309
C765	87-A12-310-080		C-CAP, U 0.01UF-50V K X7R	MAIN C.B<101K,101EZ,131EZ>			
C768	87-A12-310-080		C-CAP, U 0.01UF-50V K X7R	C101	87-A12-310-080		C-CAP, U 0.01UF-50V K X7R
C769	87-010-260-080		CAP,E 47-25 M 11L SME	C102	87-A12-310-080		C-CAP, U 0.01UF-50V K X7R
C770	87-010-596-080		CAP,S 0.047-16	C103	87-A12-310-080		C-CAP, U 0.01UF-50V K X7R
C771	87-010-383-080		CAP,E 33-25 M 11L SME	C104	87-010-404-080		CAP,E 4.7-50 M 11L SME
C772	87-010-596-080		CAP,S 0.047-16	C105	87-010-403-080		CAP,E 3.3-50 M 11L SME
C773	87-010-196-080		C-CAP,S 0.1-25 Z F C2012	C106	87-010-192-080		C-CAP,S 0.022-50 Z F C2012
C774	87-010-263-080		CAP,E 100-10 M 11L SME	C107	87-010-192-080		C-CAP,S 0.022-50 Z F C2012
C775	87-010-405-080		CAP,E 10-50 M 11L SME	C108	87-010-192-080		C-CAP,S 0.022-50 Z F C2012
C776	87-A12-310-080		C-CAP, U 0.01UF-50V K X7R	C109	87-010-192-080		C-CAP,S 0.022-50 Z F C2012
C777	87-010-400-080		CAP,E 0.47-50 M 11L SME	C110	87-A12-310-080		C-CAP, U 0.01UF-50V K X7R
C778	87-010-401-080		CAP,E 1-50 M 11L SME	C111	87-010-453-010		CAP,E 4700-25 M SME
C779	87-010-401-080		CAP,E 1-50 M 11L SME	C112	87-012-140-080		C-CAP,S 470P-50 J CH
C780	87-010-196-080		C-CAP,S 0.1-25 Z F C2012	C113	87-010-408-080		Cap. 47uF M ELEC. 50V P=5mm
C781	87-010-405-080		CAP,E 10-50 M 11L SME	C114	87-A12-310-080		C-CAP, U 0.01UF-50V K X7R
C782	87-010-405-080		CAP,E 10-50 M 11L SME	C115	87-010-112-080		CAP,E 100-16 M 11L SME
C783	87-A12-310-080		C-CAP, U 0.01UF-50V K X7R	C116	87-010-101-080		CAP,E 220-16 M SME
C784	87-A12-310-080		C-CAP, U 0.01UF-50V K X7R	C117	87-A12-310-080		C-CAP, U 0.01UF-50V K X7R
C785	87-010-401-080		CAP,E 1-50 M 11L SME				
C786	87-010-401-080		CAP,E 1-50 M 11L SME				

ELECTRICAL MAIN PARTS LIST-3/6

REF. NO	PART NO.	KANRI NO.	DESCRIPTION	REF. NO	PART NO.	KANRI NO.	DESCRIPTION
C118	87-010-263-080		CAP,E 100-10 M 11L SME	C332	87-010-187-080		C-CAP,S 5600P-50 K B
C119	87-018-047-080		Cap.0.01UF N CER. 16V Y TYPE	C333	87-010-178-080		C-CAP,S 1000P-50 K B C2012
C120	87-010-545-080		CAP,E 0.22-50 M 11L SME	C335	87-012-158-080		C-CAP,S 390P-50 J CH GRM
C121	87-010-401-080		CAP,E 1-50 M 11L SME	C336	87-012-158-080		C-CAP,S 390P-50 J CH GRM
C122	87-010-401-080		CAP,E 1-50 M 11L SME	C337	87-010-192-080		C-CAP,S 0.022-50 Z F C2012
C125	87-010-401-080		CAP,E 1-50 M 11L SME	C338	87-012-140-080		C-CAP,S 470P-50 J CH
C126	87-010-401-080		CAP,E 1-50 M 11L SME	C339	87-010-405-080		CAP,E 10-50 M 11L SME
C129	87-A10-831-090		Elect Cap. 1000uF +/-20% 25V	C340	87-010-405-080		CAP,E 10-50 M 11L SME
C130	87-A10-831-090		Elect Cap. 1000uF +/-20% 25V	C341	87-010-318-080		C-CAP,S 47P-50 J CH GRM
C131	87-A12-310-080		C-CAP, U 0.01UF-50V K X7R	C342	87-010-318-080		C-CAP,S 47P-50 J CH GRM
C132	87-A12-310-080		C-CAP, U 0.01UF-50V K X7R	C345	87-012-158-080		C-CAP, U 680P-50V K X7R
C133	87-A12-310-080		C-CAP, U 0.01UF-50V K X7R	C346	87-012-158-080		C-CAP, U 680P-50V K X7R
C134	87-A12-310-080		C-CAP, U 0.01UF-50V K X7R	C350	87-010-374-080		CAP,E 47-10 M 11L SME
C135	87-010-405-080		CAP,E 10-50 M 11L SME	C351	87-010-234-040		Cap. 47UF M Elec. 16V P=5mm
C136	87-010-404-080		CAP,E 4.7-50 M 11L SME	C354	87-012-268-080		C-CAP, U 330P-50V J COG
C139	87-010-401-080		CAP,E 1-50 M 11L SME	C355	87-012-268-080		C-CAP, U 330P-50V J COG
C140	87-010-401-080		CAP,E 1-50 M 11L SME	C701	87-010-381-080		CAP,E 330-16 M SME
C141	87-010-405-080		CAP,E 10-50 M 11L SME	C702	87-010-404-080		CAP,E 4.7-50 M 11L SME
C142	87-010-405-080		CAP,E 10-50 M 11L SME	C703	87-A12-310-080		C-CAP, U 0.01UF-50V K X7R
C143	87-010-405-080		CAP,E 10-50 M 11L SME	C704	87-A12-310-080		C-CAP, U 0.01UF-50V K X7R
C144	87-010-405-080		CAP,E 10-50 M 11L SME	C709	87-012-195-080		C-CAP,U 100P-50 J CH
C145	87-010-404-080		CAP,E 4.7-50 M 11L SME	C711	87-010-263-080		CAP,E 100-10 M 11L SME
C146	87-010-404-080		CAP,E 4.7-50 M 11L SME	C712	87-010-831-080		C-CAP,U 0.1-16 Z F
C147	87-010-408-080		Cap. 47uF M ELEC. 50V P=5mm	C713	87-A12-310-080		C-CAP, U 0.01UF-50V K X7R
C148	87-010-408-080		Cap. 47uF M ELEC. 50V P=5mm	C714	87-A12-310-080		C-CAP, U 0.01UF-50V K X7R
C151	87-010-545-080		CAP,E 0.22-50 M 11L SME	C715	87-012-195-080		C-CAP,U 100P-50 J CH
C152	87-010-545-080		CAP,E 0.22-50 M 11L SME	C717	87-A12-310-080		C-CAP, U 0.01UF-50V K X7R
C153	87-010-545-080		CAP,E 0.22-50 M 11L SME	C719	87-A12-310-080		C-CAP, U 0.01UF-50V K X7R
C154	87-010-545-080		CAP,E 0.22-50 M 11L SME	C720	87-012-195-080		C-CAP,U 100P-50 J CH
C158	87-010-263-080		CAP,E 100-10 M 11L SME	C721	87-012-176-080		C-CAP,U 15P-50 J CH
C159	87-010-182-080		C-CAP,S 2200P-50 K B C2012	C722	87-012-176-080		C-CAP,U 15P-50 J CH
C160	87-A12-310-080		C-CAP, U 0.01UF-50V K X7R	C723	87-012-274-080		C-CAP,U 1000P-50 K B
C161	87-010-263-080		CAP,E 100-10 M 11L SME	C725	87-018-131-080		CAP,TC U 1000P-50 K B UP050
C162	87-A12-310-080		C-CAP, U 0.01UF-50V K X7R	C727	87-010-196-080		C-CAP,S 0.1-25 Z F C2012
C166	87-012-368-080		C-CAP, S 0.1UF-50V K X7R	C728	87-010-248-080		CAP,E 220-10 M 11L SME
C169	87-A12-310-080		C-CAP, U 0.01UF-50V K X7R	C729	87-012-274-080		C-CAP,U 1000P-50 K B
C170	87-010-112-080		CAP,E 100-16 M 11L SME	C731	87-A12-310-080		C-CAP, U 0.01UF-50V K X7R
C171	87-010-384-080		Elect. Cap.100UF +/-20% 25V Pi	C752	87-012-284-080		C-CAP,U 6800P-50 K B GRM
C173	87-018-131-080		CAP,TC U 1000P-50 K B UP050	C753	87-012-195-080		C-CAP, U 100P-50 J CH
C174	87-012-368-080		C-CAP, S 0.1UF-50V K X7R	C755	87-A12-310-080		C-CAP, U 0.01UF-50V K X7R
C175	87-A12-310-080		C-CAP, U 0.01UF-50V K X7R	C756	87-A12-310-080		C-CAP, U 0.01UF-50V K X7R
C176	87-A12-310-080		C-CAP, U 0.01UF-50V K X7R	C757	87-012-188-080		C-CAP,U 47P-50 J CH
C177	87-010-248-080		CAP,E 220-10 M 11L SME	C758	87-012-167-080		C-CAP,U 5P-50 C CH
C303	87-010-180-080		C-CAP,S 1500P-50 K B C2012	C761	87-010-196-080		C-CAP,S 0.1-25 Z F C2012
C304	87-010-180-080		C-CAP,S 1500P-50 K B C2012	C762	87-A12-310-080		C-CAP, U 0.01UF-50V K X7R
C305	87-010-263-080		CAP,E 100-10 M 11L SME	C763	87-010-829-080		C-CAP,U 0.047-16 Z F
C306	87-010-263-080		CAP,E 100-10 M 11L SME	C764	87-012-337-080		C-CAP, U 150P-50V J COG
C307	87-010-830-080		C-CAP,U 0.068uF-16V K X7R	C765	87-A12-310-080		C-CAP, U 0.01UF-50V K X7R
C308	87-010-830-080		C-CAP,U 0.068uF-16V K X7R	C766	87-A12-310-080		C-CAP, U 0.01UF-50V K X7R
C309	87-010-188-080		C-CAP,S 6800P-50 K B C2012	C768	87-A12-310-080		C-CAP, U 0.01UF-50V K X7R
C310	87-010-188-080		C-CAP,S 6800P-50 K B C2012	C769	87-010-260-080		CAP,E 47-25 M 11L SME
C312	87-010-401-080		CAP,E 1-50 M 11L SME	C770	87-010-829-080		C-CAP,U 0.047-16 Z F
C313	87-010-401-080		CAP,E 1-50 M 11L SME	C771	87-010-383-080		CAP,E 33-25 M 11L SME
C314	87-010-401-080		CAP,E 1-50 M 11L SME	C772	87-010-829-080		C-CAP,U 0.047-16 Z F
C315	87-010-401-080		CAP,E 1-50 M 11L SME	C773	87-010-196-080		C-CAP,S 0.1-25 Z F C2012
C316	87-010-182-080		C-CAP,S 2200P-50 K B C2012	C774	87-010-263-080		CAP,E 100-10 M 11L SME
C317	87-010-182-080		C-CAP,S 2200P-50 K B C2012	C775	87-010-405-080		CAP,E 10-50 M 11L SME
C318	87-A12-364-080		Cap. 0.01 uF K Mylar 100V AI	C776	87-A12-310-080		C-CAP, U 0.01UF-50V K X7R
C319	87-A12-364-080		Cap. 0.01 uF K Mylar 100V AI	C777	87-010-400-080		CAP,E 0.47-50 M 11L SME
C320	87-A10-295-080		Cap. 0.01UF J Mylar 50V AI	C778	87-010-401-080		CAP,E 1-50 M 11L SME
C321	87-A10-295-080		Cap. 0.01UF J Mylar 50V AI	C779	87-010-401-080		CAP,E 1-50 M 11L SME
C322	87-010-321-080		C-CAP,S 82P-50 J CH	C780	87-010-196-080		C-CAP,S 0.1-25 Z F C2012
C323	87-010-321-080		C-CAP,S 82P-50 J CH	C781	87-010-405-080		CAP,E 10-50 M 11L SME
C324	87-010-112-080		CAP,E 100-16 M 11L SME	C782	87-010-405-080		CAP,E 10-50 M 11L SME
C325	87-010-112-080		CAP,E 100-16 M 11L SME	C783	87-A12-310-080		C-CAP, U 0.01UF-50V K X7R
C326	87-010-192-080		C-CAP,S 0.022-50 Z F C2012	C784	87-A12-310-080		C-CAP, U 0.01UF-50V K X7R
C327	87-010-183-080		C-CAP,S 2700P-50 K B GRM	C785	87-010-401-080		CAP,E 1-50 M 11L SME
C328	87-010-183-080		C-CAP,S 2700P-50 K B GRM	C786	87-010-401-080		CAP,E 1-50 M 11L SME
C329	87-010-183-080		C-CAP,S 2700P-50 K B GRM	C787	87-012-287-080		C-CAP, U 0.015-25 Z F
C331	87-010-382-080		CAP,E 22-25 M 11L SME	C788	87-012-287-080		C-CAP,U 0.015-25 Z F

ELECTRICAL MAIN PARTS LIST-4/6

REF. NO	PART NO.	KANRI NO.	DESCRIPTION	REF. NO	PART NO.	KANRI NO.	DESCRIPTION
C789	87-012-275-080		C-CAP,U 1200P-50 K B GRM	WH101	87-099-043-010		CONN 2P EH
C790	87-012-275-080		C-CAP,U 1200P-50 K B GRM	X721	87-A70-061-010		VIB,XTAL 4.500MHZ CSA-309
C791	87-010-405-080		CAP,E 10-50 M 11L SME	X851	87-A70-184-010		VIB,XTAL 4.332MHZ HC-49/U<131EZ>
C793	87-012-273-080		C-CAP, U 820P-50V K X7R				
C794	87-010-406-080		CAP,E 22-50 M 11L SME				
							FRONT C.B
C795	87-010-596-080		C-CAP,S 0.047-16 K R C2012	C201	87-010-375-080		CAP,E 330-10 M 11L SME
C796	87-010-403-080		CAP,E 3.3-50 M 11L SME	C202	87-010-805-080		C-CAP,S 1uF-16V Z CER.Y5V
C797	87-012-276-080		C-CAP,U 1500P-50 K B	C203	87-A12-310-080		C-CAP, U 0.01UF-50V K X7R
C798	87-012-276-080		C-CAP,U 1500P-50 K B	C204	87-A12-310-080		C-CAP, U 0.01UF-50V K X7R
C799	87-010-829-080		C-CAP,U 0.047-16 Z F	C205	87-012-156-080		C-CAP,S 220P-50 J CH GRM
C812	87-A12-310-080		C-CAP, U 0.01UF-50V K X7R	C206	87-A12-310-080		C-CAP, U 0.01UF-50V K X7R
C814	87-A12-310-080		C-CAP, U 0.01UF-50V K X7R	C207	87-A12-310-080		C-CAP, U 0.01UF-50V K X7R
C820	87-010-260-080		CAP,E 47-25 M 11L SME	C208	87-010-196-080		C-CAP,S 0.1-25 Z F C2012
C821	87-A12-310-080		C-CAP, U 0.01UF-50V K X7R	C210	87-010-196-080		C-CAP,S 0.1-25 Z F C2012
C822	87-A12-310-080		C-CAP, U 0.01UF-50V K X7R	C211	87-010-314-080		C-CAP,S 22P-50V
C823	87-A12-310-080		C-CAP, U 0.01UF-50V K X7R	C212	87-010-321-080		C-CAP,S 82P-50 J CH
C824	87-012-172-080		C-CAP,U 10P-50 D CH	C213	87-012-168-080		C-CAP U 6 P-50V C CER. COG
C828	87-010-196-080		C-CAP,S 0.1-25 Z F C2012	C214	87-010-314-080		C-CAP,S 22P-50V
C829	87-010-196-080		C-CAP,S 0.1-25 Z F C2012	C215	87-012-176-080		C-CAP,U 15P-50 J CH
C859	87-010-190-080		C-CAP,S 0.01-50 Z F C2012<131EZ>	C216	87-010-400-080		CAP,E 0.47-50 M 11L SME
C861	87-012-156-080		C-CAP,S 220P-50 J CH GRM<131EZ>	C217	87-010-196-080		C-CAP,S 0.1-25 Z F C2012
C862	87-012-156-080		C-CAP,S 220P-50 J CH GRM<131EZ>	C218	87-010-405-080		CAP,E 10-50 M 11L SME
C863	87-012-270-080		C-CAP,U 470P-50 K B<131EZ>	CN201	87-099-720-010		CONN,30P BLK TYK-B(P)
C864	87-010-405-080		CAP,E 10-50 M 11L SME<131EZ>	CN202	87-A60-404-010		CONN,3P TKX-P03P-F1
C865	87-010-196-080		C-CAP,S 0.1-25 Z F C2012<131EZ>	FB201	87-A90-562-010		F-BCAD 843556 TB36 TAPING 52mm
C866	87-010-405-080		CAP,E 10-50 M 11L SME<131EZ>	L201	87-005-676-080		COIL,2.2UH K LF5.0S
C867	87-010-190-080		C-CAP,S 0.01-50 Z F C2012<131EZ>	L202	87-A50-083-080		FIXED INDUCTOR 47uH CECS-470K
C868	87-012-184-080		C-CAP,U 470P-50 J CH<131EZ>	LCD201	8Z-CL8-665-110		LCD,ZCL-8
C869	87-010-314-080		C-CAP,S 22P-50V<131EZ>	R244	88-130-100-080		RES 10 OHM 1/4W J 52mm TAPE<131U>
C909	87-A12-310-080		C-CAP, U 0.01UF-50V K X7R	S200	87-A90-095-080		SW,TACT EVQ11G04M
C910	87-A12-310-080		C-CAP, U 0.01UF-50V K X7R	S201	87-A90-095-080		SW,TACT EVQ11G04M
C940	87-A12-310-080		C-CAP, U 0.01UF-50V K X7R	S202	87-A90-095-080		SW,TACT EVQ11G04M
C942	87-012-172-080		C-CAP,U 10P-50 D CH	S203	87-A90-095-080		SW,TACT EVQ11G04M
C947	87-A12-310-080		C-CAP, U 0.01UF-50V K X7R	S204	87-A90-095-080		SW,TACT EVQ11G04M
C949	87-A10-039-080		C-CAP,U 470P-50 J CH	S205	87-A90-095-080		SW,TACT EVQ11G04M
C952	87-A12-310-080		C-CAP, U 0.01UF-50V K X7R	S206	87-A90-095-080		SW,TACT EVQ11G04M
C958	87-A12-310-080		C-CAP, U 0.01UF-50V K X7R	S207	87-A90-095-080		SW,TACT EVQ11G04M
C959	87-010-831-080		C-CAP,U 0.1-16 Z F	S208	87-A90-095-080		SW,TACT EVQ11G04M
C960	87-010-196-080		C-CAP,S 0.1-25 Z F C2012	S209	87-A90-095-080		SW,TACT EVQ11G04M
C962	87-010-401-080		CAP,E 1-50 M 11L SME	S210	87-A90-095-080		SW,TACT EVQ11G04M<101LH,131U>
CF801	87-008-423-010		FLTR,CF SFE10.7MS3G-A	S213	87-A90-095-080		SW,TACT EVQ11G04M
CF802	82-785-747-010		CF MS2 GLY R	S214	87-A90-095-080		SW,TACT EVQ11G04M
CN101	88-NF9-658-010		CONN,30P BLK TYK-B(P)	S215	87-A90-095-080		SW,TACT EVQ11G04M
CN301	87-099-832-010		CONN,8P V S2M-8W	S216	87-A90-095-080		SW,TACT EVQ11G04M
△F101	87-035-457-010		FUSE,3.15A 250V T 218	S217	87-A90-095-080		SW,TACT EVQ11G04M
FC101	87-033-213-080		FUSE CLAMP,PFC5000	S218	87-A90-095-080		SW,TACT EVQ11G04M
FC102	87-033-213-080		FUSE CLAMP,PFC5000	S219	87-A90-095-080		SW,TACT EVQ11G04M
FFE801	A8-6ZA-19C-170		6ZA-1 YFEENC	X201	87-030-364-010		VIB,XTAL 32.768K CT
J101	87-099-715-010		RCA Jack (HSP-242V-05)	X202	87-030-376-080		VIB,CER 5.760MHZ CSA MG200
J102	87-A60-754-010		Speaker Terminal 4 pins Push t				
J103	87-A60-420-010		Stereo Headphone Jack (DC:34V/				
J104	87-099-608-010		DC JACK HEC3800 (500V)				
J801	87-A60-880-010		TERMINAL,ANT-PAL 2P MSP-313V-0				
L101	87-005-366-010		COIL,1UH K				
L102	87-005-366-010		COIL,1UH K				
L104	87-005-676-080		COIL,2.2UH K LF5.0S				
L301	87-007-342-010		COIL OSC 85K BIAS				
L771	87-A50-266-010		COIL,FM DET-2N(TOK)				
L772	87-A90-733-010		FLTR,PCFAZH-450 (TOK)				
L773	S6-047-410-000		AN ANT COIL PIN:4-5:99T				
L774	S6-047-510-000		AM OSC COIL PIN:5-4:21T				
L781	87-005-847-080		COIL,2.2UH K CECS				
L832	87-005-847-080		COIL,2.2UH K CECS				
L851	87-005-847-080		COIL,2.2UH K CECS<131EZ>				
L941	87-A50-020-010		COIL,ANT LW (COI) 252KHZ				
L942	87-A50-019-010		COIL,OSC LW (COI) 856KHZ				
△PR100	87-A91-940-080		PROTECTOR,2.5A 20P 60V				
R118	SR-F82-000-25N		RES,FUSE 82-1/2W J				
R857	88-121-104-070		100 K 1/8W J RES. 26mm TAPE<131EZ>				
TC942	87-011-164-010		TRIMMER,CER 30P 4.5X3.9 VCT31				
							CD C.B
				C401	87-010-403-080		CAP,E 3.3-50 M 11L SME
				C402	87-010-197-080		C-CAP,S 0.01-25 K B C2012
				C403	87-010-263-080		CAP,E 100-10 M 11L SME
				C404	87-010-248-080		CAP,E 220-10 M 11L SME
				C405	87-010-197-080		C-CAP,S 0.01-25 K B C2012
				C406	87-010-374-080		CAP,E 47-10 M 11L SME
				C407	87-010-178-080		C-CAP,S 1000P-50 K B C2012
				C408	87-010-198-080		C-CAP,S 0.022-25 K B C2012
				C409	87-010-248-080		CAP,E 220-10 M 11L SME
				C410	87-010-263-080		CAP,E 100-10 M 11L SME
				C411	87-A11-177-080		C-CAP,S 0.15-16 K B
				C412	87-010-401-080		CAP,E 1-50 M 11L SME
				C413	87-016-369-080		C-CAP,S 0.033-25 K B GRM
				C414	87-010-405-080		CAP,E 10-50 M 11L SME
				C415	87-012-368-080		C-CAP, S 0.1UF-50V K X7R
				C416	87-010-545-080		CAP,E 0.22-50 M 11L SME
				C417	87-012-157-080		C-CAP,S 330P-50 J CH GRM

ELECTRICAL MAIN PARTS LIST-5/6

C418	87-010-213-080	C-CAP,S 0.015-25 K B GRM	C496	87-010-403-080	CAP,E 3.3-50 M 11L SME
C419	87-A10-201-080	C-CAP,S 0.33-16 K B	C501	87-010-196-080	C-CAP,S 0.1-25 Z F C2012
C420	87-016-369-080	C-CAP,S 0.033-25 K B GRM	C502	87-010-322-080	C-CAP,S 100P-50 J CH GRM
C421	87-A11-177-080	C-CAP,S 0.15-16 K B	C503	87-010-322-080	C-CAP,S 100P-50 J CH GRM
C422	87-010-184-080	C-CAP,S 3300P-50 K B C2012	C504	87-010-322-080	C-CAP,S 100P-50 J CH GRM
C423	87-010-992-080	C-CAP,S 0.047-25 K B MK212	C505	87-010-322-080	C-CAP,S 100P-50 J CH GRM
C424	87-016-460-080	C-CAP,S 0.22-16 K B	C506	87-010-322-080	C-CAP,S 100P-50 J CH GRM
C425	87-010-176-080	C-CAP,S 680P-50 J SL	C510	87-012-368-080	C-CAP, S 0.1UF-50V K X7R
C426	87-A10-201-080	C-CAP,S 0.33-16 K B	CN203	87-A60-080-010	CONN,07P H 9604S-07F
C428	87-010-197-080	C-CAP,S 0.01-25 K B C2012	CN401	87-A60-424-010	CONN,16P V TOC-B
C429	87-010-186-080	C-CAP,S 4700P-50 K B C2012	CN402	87-A60-670-010	CONN,6P H 2MM JMT
C430	87-012-156-080	C-CAP,S 220P-50 J CH GRM	CN403	87-A60-619-010	CONN,2P V 2MM JMT
C431	87-010-545-080	CAP,E 0.22-50 M 11L SME	FFC203	88-907-121-110	FF-CABLE, 7P 1.25 120MM
C432	87-010-374-080	CAP,E 47-10 M 11L SME	FFC401	8B-CLB-601-010	FF-CABLE,16P 1.0 130MM
C433	87-010-401-080	CAP,E 1-50 M 11L SME	L401	87-003-102-080	COIL,10UH J LAL02
C434	87-010-184-080	C-CAP,S 3300P-50 K B C2012	L403	87-A50-087-080	Fixed Inductor 100uH CECSS +/-
C435	87-010-197-080	C-CAP,S 0.01-25 K B C2012	L404	87-A50-079-080	Fixed Inductor 22uH CECSS +/-
C436	87-010-374-080	CAP,E 47-10 M 11L SME	SFR430	87-024-437-080	SFR, 100K H NVZ6TLTA AI TAPING
C437	87-010-404-080	CAP,E 4.7-50 M 11L SME	X401	87-A70-046-010	VIB,XTAL 16.934MHZ
C438	87-012-368-080	C-CAP, S 0.1UF-50V K X7R			
C439	87-010-178-080	C-CAP,S 1000P-50 K B C2012	LED C.B		
C441	87-010-197-080	C-CAP,S 0.01-25 K B C2012	D941	87-A40-365-080	LED LAMP Green SLR-342 MGT32
C442	87-010-313-080	C-CAP,S 18P-50 J CH GRM	D942	87-A40-365-080	LED LAMP Green SLR-342 MGT32
C445	87-010-196-080	C-CAP,S 0.1-25 Z F C2012	D943	87-A40-365-080	LED LAMP Green SLR-342 MGT32
C446	87-010-196-080	C-CAP,S 0.1-25 Z F C2012	D944	87-A40-365-080	LED LAMP Green SLR-342 MGT32
C447	87-010-196-080	C-CAP,S 0.1-25 Z F C2012	D945	87-A40-365-080	LED LAMP Green SLR-342 MGT32
C448	87-010-322-080	C-CAP,S 100P-50 J CH GRM	D946	87-A40-365-080	LED LAMP Green SLR-342 MGT32
C450	87-012-140-080	C-CAP,S 470P-50 J CH	D947	87-A40-365-080	LED LAMP Green SLR-342 MGT32
C451	87-012-156-080	C-CAP,S 220P-50 J CH GRM	D948	87-A40-365-080	LED LAMP Green SLR-342 MGT32
C455	87-010-247-080	CAP,E 100-50 M SME	D949	87-A40-365-080	LED LAMP Green SLR-342 MGT32
C457	87-010-312-080	C-CAP,S 15P-50 J CH GRM			
C458	87-010-312-080	C-CAP,S 15P-50 J CH GRM			
C459	87-010-263-080	CAP,E 100-10 M 11L SME	AC C.B		
C460	87-015-819-080	C-CAP, 0.01-50 K B C3216	△C219	87-010-197-080	C-CAP, S 0.01-25 K B C2012
C461	87-010-197-080	C-CAP,S 0.01-25 K B C2012			<101K,101EZ,131EZ>
C462	87-010-248-080	CAP,E 220-10 M 11L SME	△C219	87-010-196-080	CHIP CAPACITOR,0.1-25<131U>
C463	87-012-348-080	Cap. 0.1uF Z CER. 50V F TYPE	△C220	87-010-197-080	C-CAP, S 0.01-25 K B C2012
C464	87-010-263-080	CAP,E 100-10 M 11L SME			<101K,101EZ,131EZ>
C465	87-010-404-080	CAP,E 4.7-50 M 11L SME	△C220	87-010-196-080	CHIP CAPACITOR,0.1-25<131U>
C466	87-010-196-080	C-CAP,S 0.1-25 Z F C2012	CNA101	8A-CLA-630-010	CONN ASSY,2P PT<EXCEPT 131U>
C467	87-010-263-080	CAP,E 100-10 M 11L SME	△PT101	8B-CLA-602-010	POWER TRANSFORMER EN60065
C469	87-012-154-080	C-CAP,S 150P-50 J CH GRM			<101K,101EZ,131EZ>
C470	87-010-544-080	CAP,E 0.1-50 M 11L SME	△PT101	8B-CLA-604-010	POWER TRANSFORMER IEC-65<101LH>
C471	87-015-785-080	C-CAP, 0.1-25 Z F C3216	△PT101	8B-CLA-603-010	PT,U BCL-A<131U>
C472	87-015-785-080	C-CAP, 0.1-25 Z F C3216	△SW001	87-A90-178-010	SW,SL 1-1-2 KUN<101LH>
C473	87-015-785-080	C-CAP, 0.1-25 Z F C3216	W101	8Z-CL8-691-010	F-CABLE,3P 2.5 180MM<131U>
C474	87-015-785-080	C-CAP, 0.1-25 Z F C3216			
C475	87-010-197-080	C-CAP,S 0.01-25 K B C2012	MOTOR C.B		
C476	87-010-221-080	CAP,E 470-10 M SME	M1	S0-M10-A09-700	MOTOR SLED ASSY
C477	87-010-197-080	C-CAP,S 0.01-25 K B C2012	PIN3	S2-369-750-000	PLUG,6P
C478	87-010-263-080	CAP,E 100-10 M 11L SME	SW1	S4-S13-A01-600	SW,LEAF
C479	87-010-197-080	C-CAP,S 0.01-25 K B C2012			
C480	87-010-221-080	CAP,E 470-10 M SME	DECK C.B		
C481	87-010-405-080	CAP,E 10-50 M 11L SME	CN1	87-A60-080-010	CONN,07P H 9604S-07F
C482	87-010-405-080	CAP,E 10-50 M 11L SME	CRD1	8A-ZM6-603-010	REN,CORD,2P-75
C489	87-010-196-080	C-CAP,S 0.1-25 Z F C2012	SW1	87-A90-673-010	SW,MICRO ESE11SH1C
C490	87-010-196-080	C-CAP,S 0.1-25 Z F C2012	SW2	87-A90-673-010	SW,MICRO ESE11SH1C
C491	87-010-197-080	C-CAP,S 0.01-25 K B C2012	SW3	87-A90-673-010	SW,MICRO ESE11SH1C
C492	87-010-221-080	CAP,E 470-10 M SME			
C494	87-012-348-080	Cap. 0.1uF Z CER. 50V F TYPE			

ELECTRICAL MAIN PARTS LIST-6/6

- Regarding connectors, they are not stocked as they are not the initial order items.
The connectors are available after they are supplied from connector manufacturers upon the order is received.

○チップ抵抗部品コード/CHIP RESISTOR PART CODE

チップ抵抗部品コードの成り立ち

Chip Resistor Part Coding

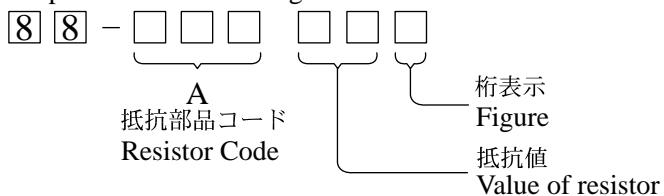

チップ抵抗 Chip resistor

容量 Wattage	種類 Type	許容誤差 Tolerance	記号 Symbol	寸法/Dimensions (mm)			抵抗コード : A Resistor Code : A	
				外形/Form	L	W		t
1/16W	1005	± 5%	CJ		1.0	0.5	0.35	104
1/16W	1608	± 5%	CJ		1.6	0.8	0.45	108
1/10W	2125	± 5%	CJ		2	1.25	0.45	118
1/8W	3216	± 5%	CJ		3.2	1.6	0.55	128

TRANSISTOR ILLUSTRATION-1/1

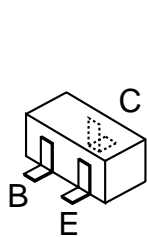

2SC2714
2SD1306
DTC114TK
DTC143TK
DTC144EK
RT1P141C
PT1P144C
DTC124XK



ECB
2SA1296
KTC3198

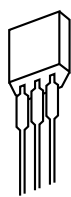

ECB
DTC124XS
DTC343TS
2SA1993F
DTC144ES
2SC3052F
2SC3331



ECB
2SA933
2SC2001
SS8050
2SC4115SR
2SA1979
2SD1858TV
2SA952



ECB
2SD1381

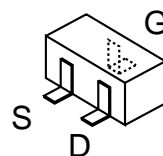

2SK543



BCE
2SC5343G



SDG
2SJ460

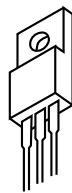

BCE
KTA1046

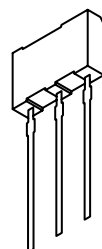

ECB
2SB1240

MAIN C.B

101LH,131U MODEL

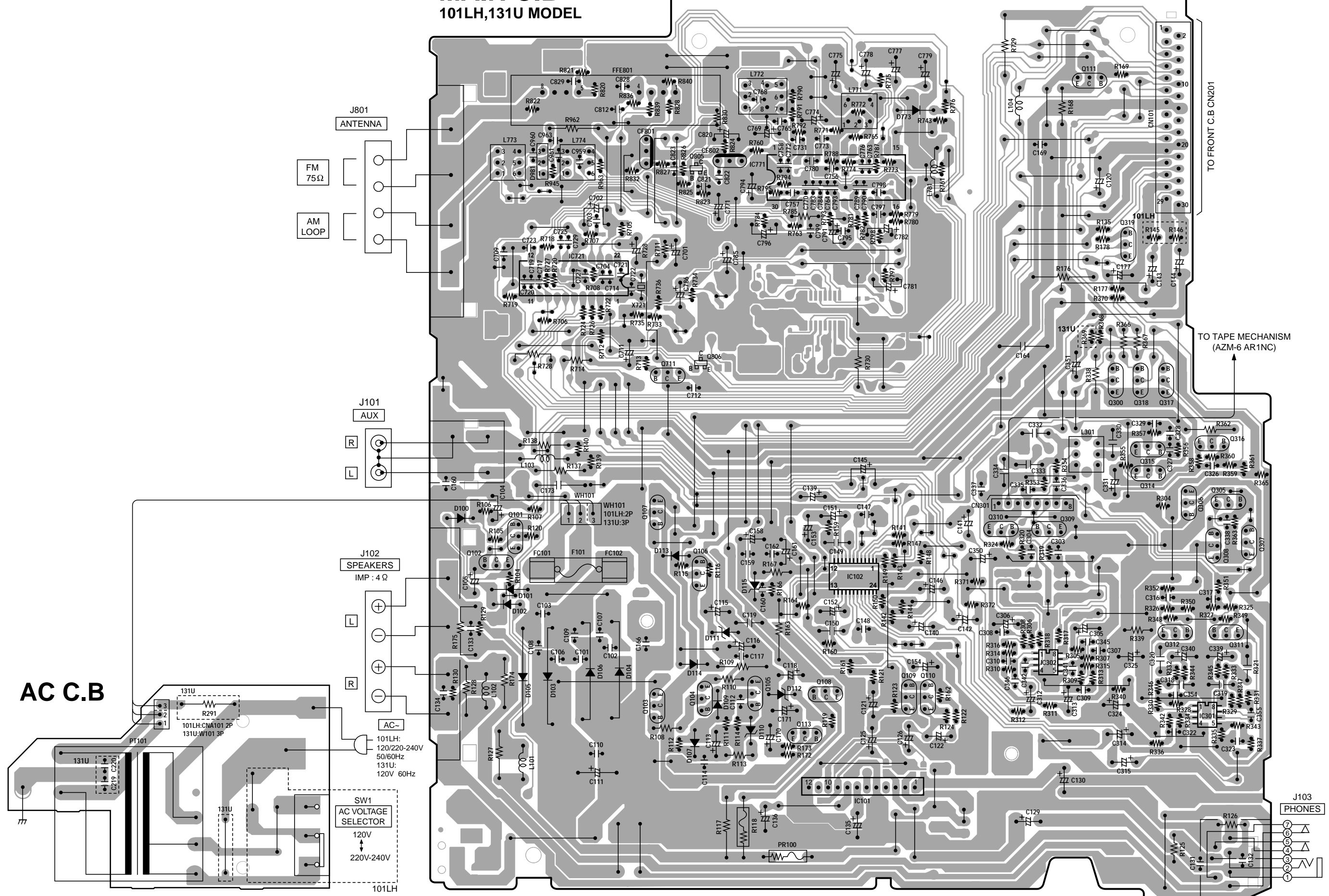

A
B
C
D
E
F
G
H
I
J
K
L
M
N
O
P
Q
R
S
T
U

MAIN C.B

101K,EZ,131EZ MODEL

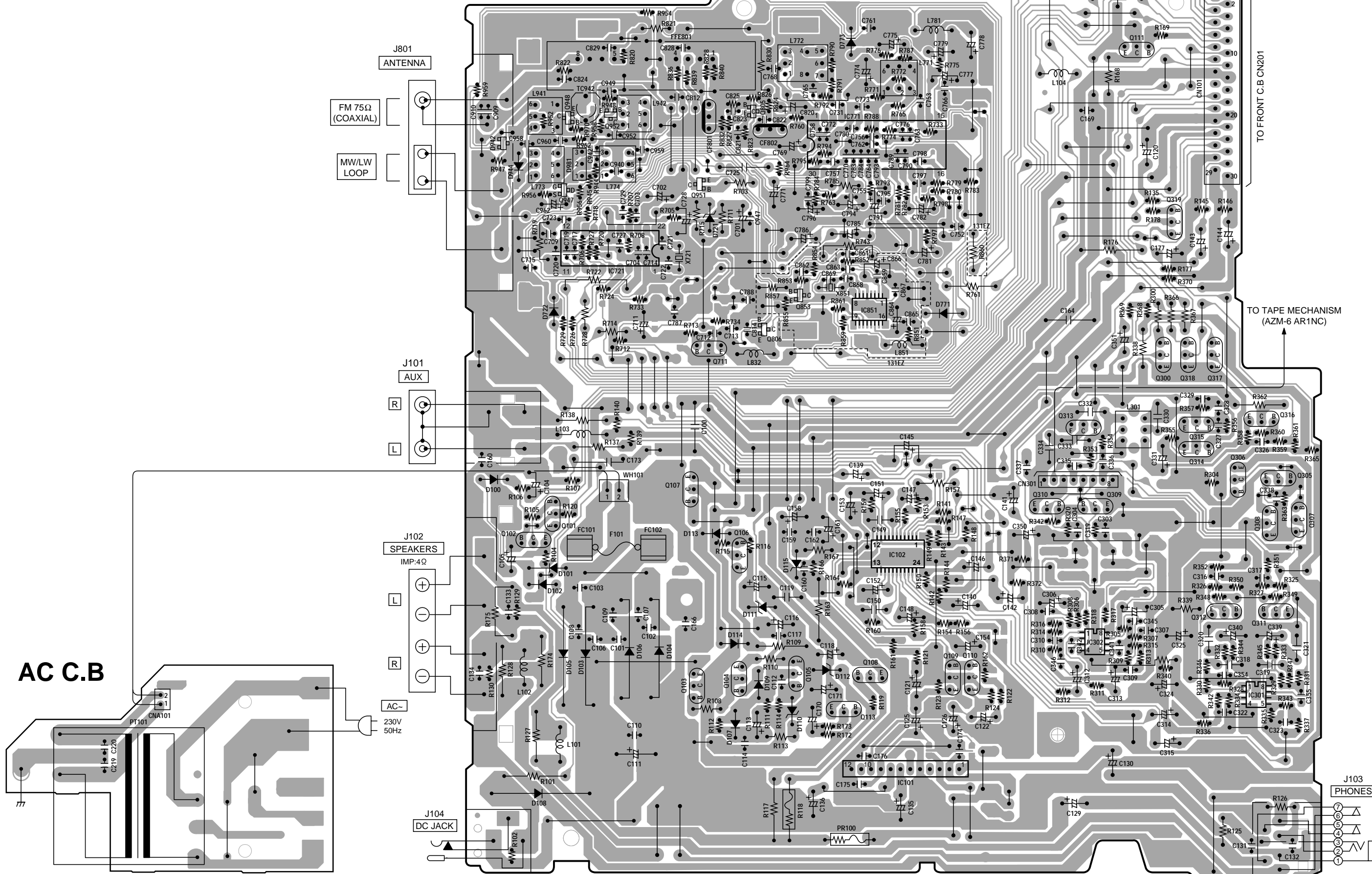

A
B
C
D
E
F
G
H
I
J
K
L
M
N
O
P
Q
R
S
T
U

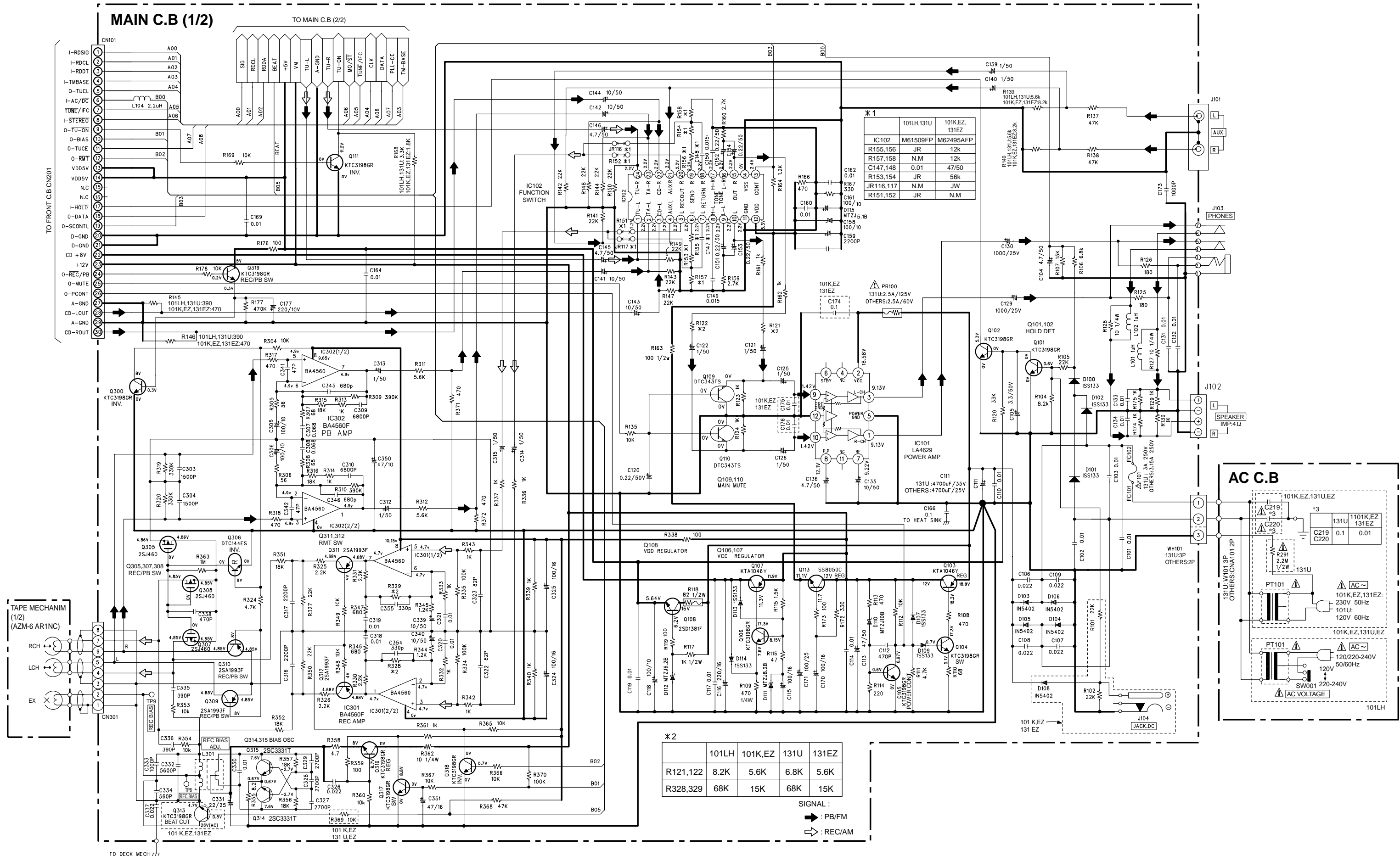

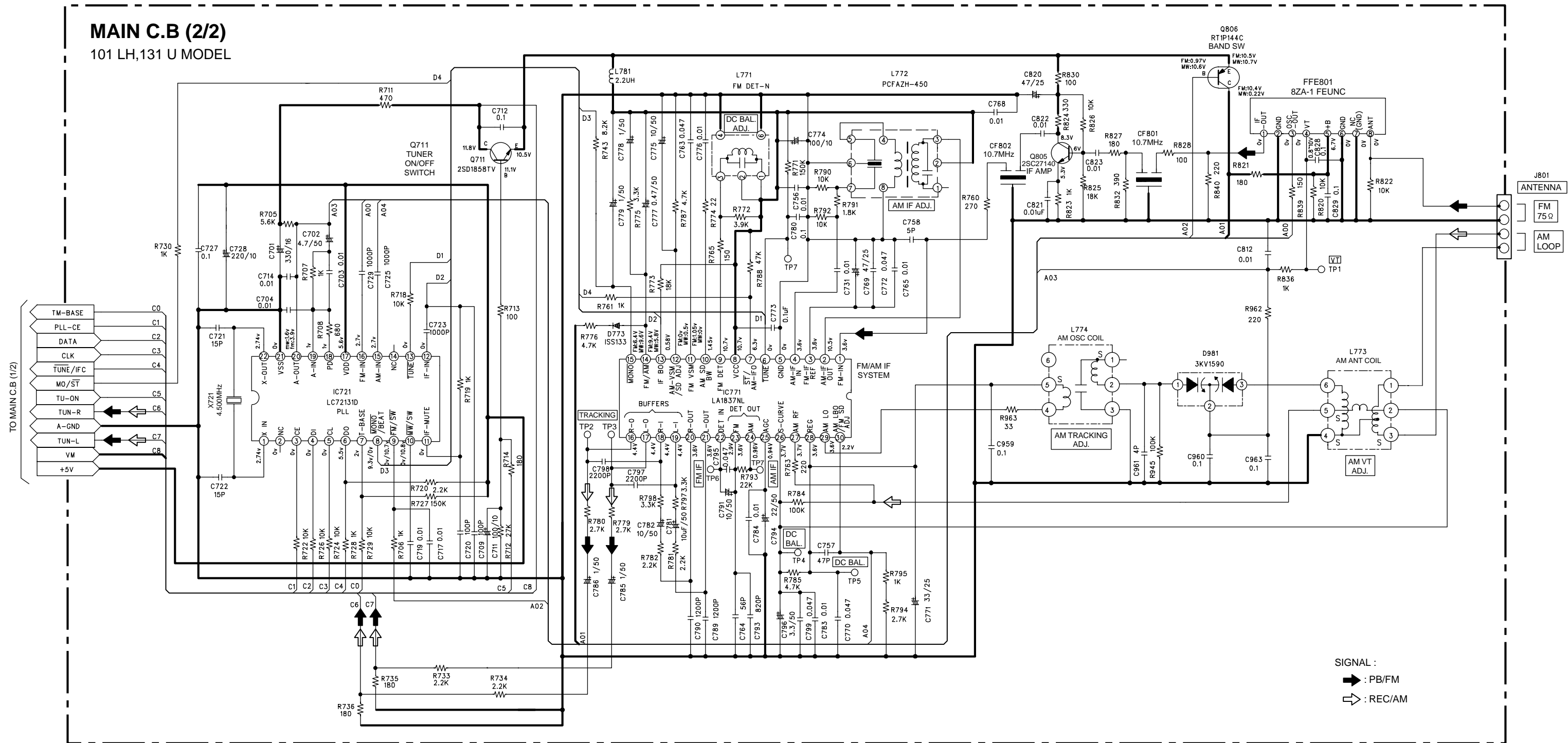

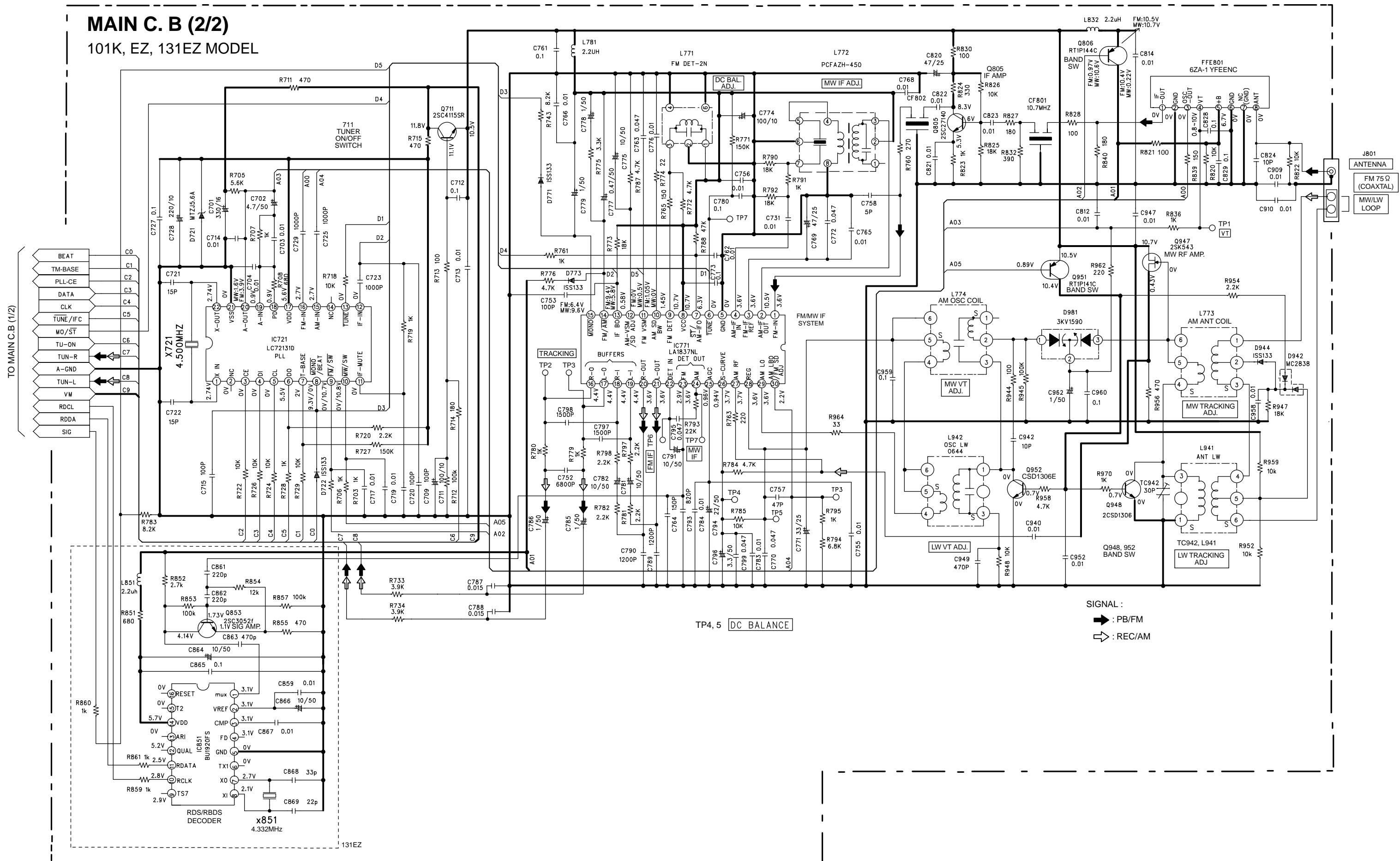

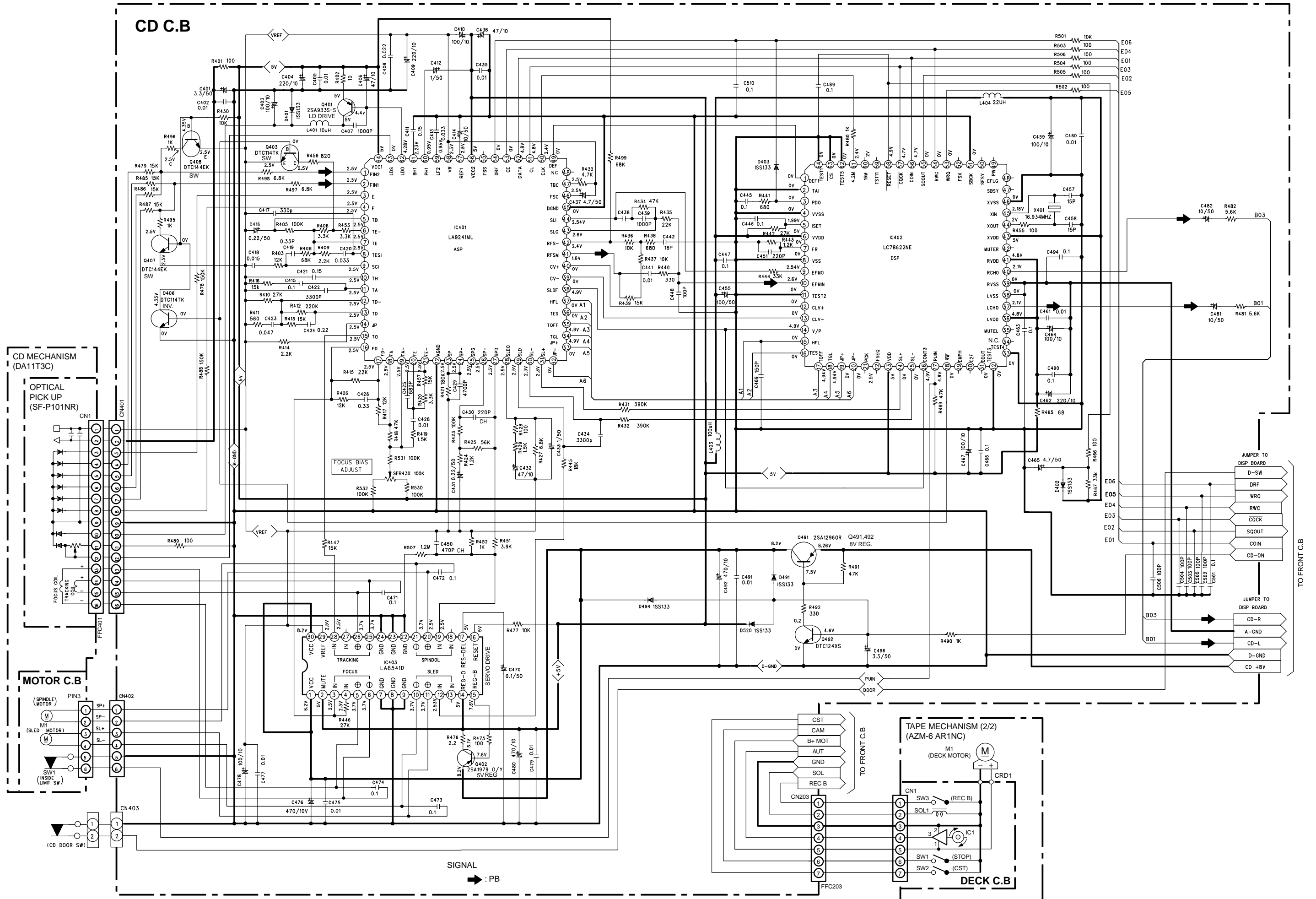

GRID ASSIGNMENT

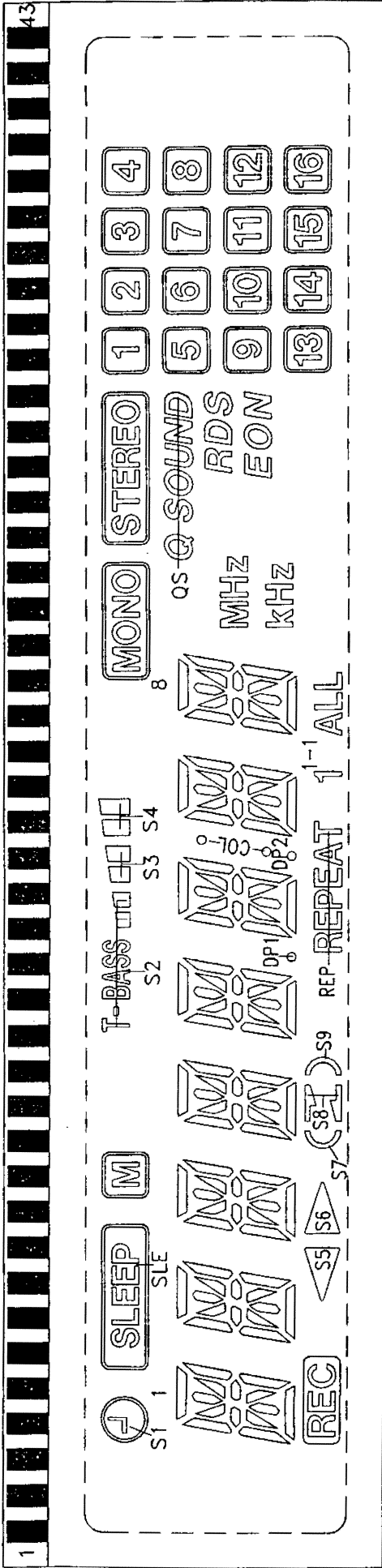

ANODE CONNECTION

PIN	COM1	COM2	COM3	COM4	PIN	COM1	COM2	COM3	COM4
1	1D	1E	1F	REC	23	6N	6G	6H	6I
2	1N	1G	1H	1I	24	6M	6K	6J	6A
3	1M	1K	1J	1A	25	6L	6C	6B	COL
4	1L	1C	1B	S1	26	7D	7E	7F	DP2
5	2D	2E	2F	S5	27	7N	7G	7H	7I
6	2N	2G	2H	2I	28	7M	7K	7J	7A
7	2M	2K	2J	2A	29	7L	7C	7B	/
8	2L	2C	2B	SLE	30	8D	8E	8F	REP
9	3D	3E	3F	S6	31	8N	8G	8H	8I
10	3N	3G	3H	3I	32	8M	8K	8J	8A
11	3M	3K	3J	3A	33	8L	8C	8B	MONO
12	3L	3C	3B	M	34	ALL	KHZ	MHZ	1-1
13	4D	4E	4F	S7	35	EON	RDS	QS	STE
14	4N	4G	4H	4I	36	13	9	5	1
15	4M	4K	4J	4A	37	14	10	6	2
16	4L	4C	4B	/	38	15	11	7	3
17	5D	5E	5F	S8	39	16	12	8	4
18	5N	5G	5H	5I	40	/	/	/	COM4
19	5M	5K	5J	5A	41	/	/	COM3	/
20	5L	5C	5B	S9	42	/	COM2	/	/
21	DP1	S4	S3	S2	43	COM1	/	/	/
22	6D	6E	6F	/	/	/	/	/	/

ELECTRICAL ADJUSTMENT-1/2 (101LH, 131U MODEL)

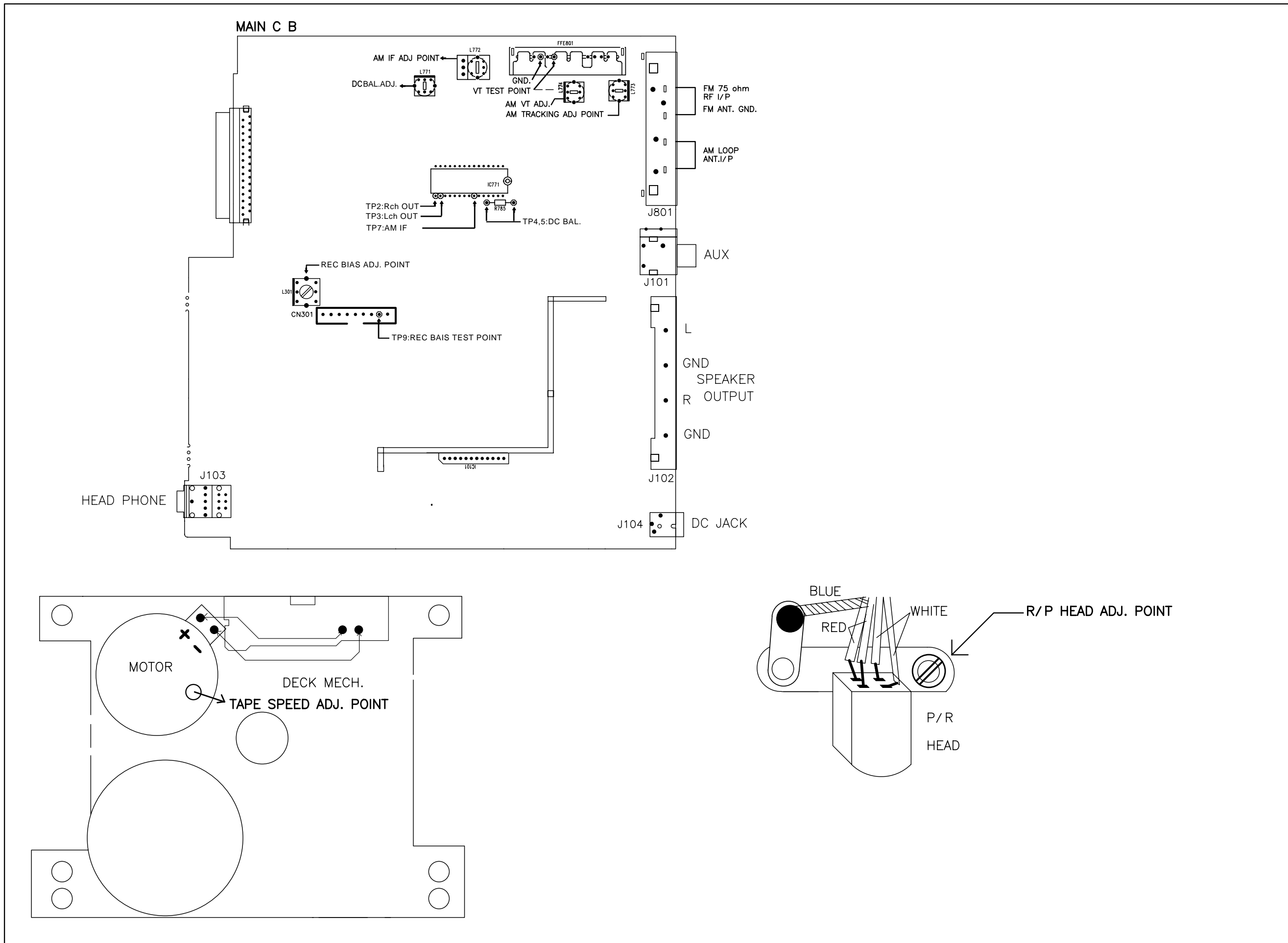

ELECTRICAL ADJUSTMENT (101LH 131U MODEL)

DECK ADJUSTMENT

1. TAPE SPEED ADJUSTMENT

Requirements

- Measuring equipments : wow-flutter meter (frequency counter)
Test Tape: TTA-100 (3KHz)
Test point: HP OUT
Adjustment point : Tape speed adjustment point (motor)

- 1) Connect HP OUT to the Wow - flutter meter.
- 2) Insert the test tape (TTA-100), play back center of the tape and adjust the motor until it becomes $3,000\text{Hz} \pm 30\text{Hz}$.

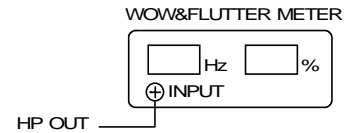

2. WOW – FLUTTER CHECK

Requirements

- Test tape: TTA-100 (3KHz)
Test point: HP OUT

- 1) Connect the HP OUT to the Wow – flutter meter.
- 2) Set the indicator to JIS and the mode to W RMS (WTD) of the Wow – flutter meter.
- 3) Play back the center of the test tape (TTA-100) and check that it is below 0.35%.

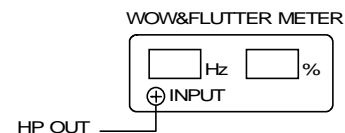

3. HEAD AZIMUTH ADJUSTMENT

Requirements

- Measuring equipment: Oscilloscope
Test Tape: TTA-330 (8KHz)
Test point: HP OUT
Adjustment point: Head azimuth screw

- 1) Connect the HP OUT to the oscilloscope of CH1 and CH2.
- 2) Set the V mode of the oscilloscope to ADD.
- 3) Insert the test tape (TTA-330) , play back the center of the tape and adjustment the head azimuth screw until the waveform of the oscilloscope has reached the maximum when playing back at 10KHz.
- 4) After the adjustment, bond lock (1600B) the screw.

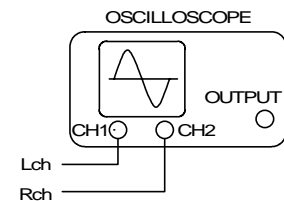

4. REC. BIAS FREQUENCY ADJUSTMENT

Requirement

- Measuring equipment: frequency counter
Test point: TP9

- 1) Connect the TP9 to the frequency counter.
- 2) Set the recording condition to the main unit.
- 3) Adjust the L301 until it becomes $85\text{KHz} \pm 5\text{KHz}$.

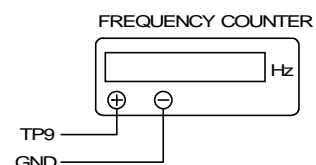

TUNER ADJUSTMENT

1 . VT ADJUSTMENT (AM)

Requirement

Measuring equipment: Digital multi-meter

Test point: TP1(FFE801 pin),GND

Adjustment point: L773

- (1) Adjust the reception frequency of the main unit to 1710KHz.
- (2) Adjust L773 until the test point voltage (VT) is $9.0V \pm 0.5V$.
- (3) Adjust the reception frequency of the main unit to 530KHz.
- (4) Check that the test point (VT) voltage is about 1.3V.

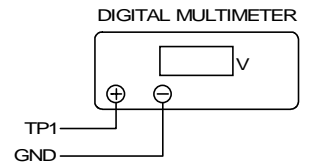

2 . VT CHECK (FM)

Requirement

Measuring equipment: Digital multi-meter

Test point: TP1(FFE801 pin),GND

- (1) Adjust the reception frequency of the main unit to 108.0MHz.
- (2) Check that the test point (VT) voltage is about 9.0V.
- (3) Adjust the reception frequency of the main unit to 87.5MHz.
- (4) Check that the test point (VT) voltage is about 2.5V.

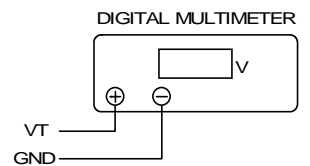

3 . DC BALANCE ADJUSTMENT

Requirement

Measuring equipment: Digital multi-meter

Test point: TP4, 5

Adjustment point: L771

- (1) Adjust the reception frequency of the main unit to 98.0MHz.
- (2) Adjust L771 until the test point voltage difference between TP4 and TP5 is $0mV \pm 20mV$.

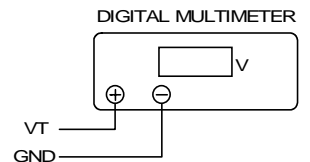

< AM ADJUSTMENT >

For AM adjustment, do wiring and connection as in the following.

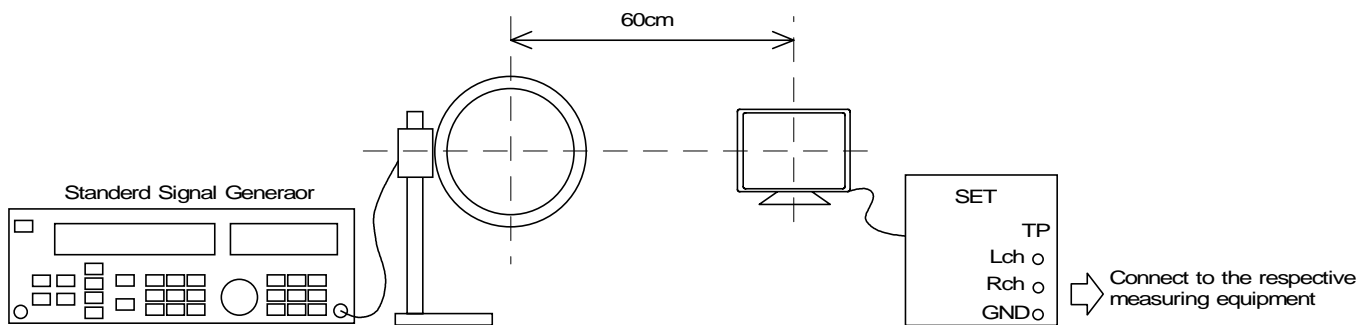

4 . IF ADJUSTMENT

Requirement

Measuring equipment: Oscilloscope or Millivoltmeter

Test point: TP7 (IC771 24pin), GND

Adjustment point: L772

- (1) Adjust the setting of Standard Signal Generator (hereinafter S.S.G.) to 450KHz of 30% variation.
- (2) While looking at the waveform on the oscilloscope, reduce the output level all the way.
- (3) Adjust L802 until the waveform of the oscilloscope reaches the maximum.

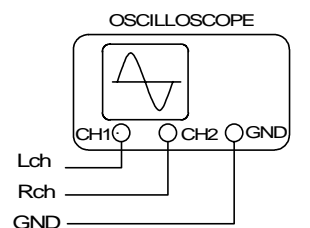

5 . TRACKING ADJUSTMENT

Requirement

Measuring equipment: Millivoltmeter

Test point: TP2, TP3, GND

Adjustment point: L774

- (1) Adjust the S.S.G. setting to 1000KHz of 30% variation and reduce the output level all the way.
- (2) Adjust the reception frequency of the main unit to 1000KHz.
- (3) Adjust L774 until the value of the millivoltmeter reaches the maximum.

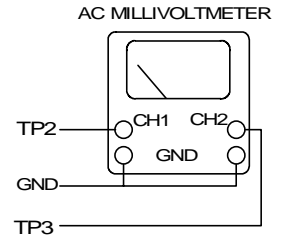

< FM ADJUSTMENT >

For adjusting FM, do wiring function and connection as in the following.

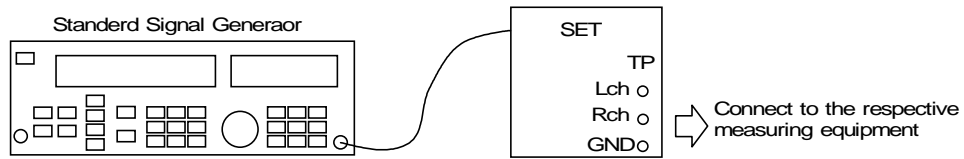

6 . TRACKING CHECK

Requirement

Measuring equipment: millivoltmeter

Test point: TP2, TP3, GND

- (1) Adjust the S.S.G. setting to 83.0MHz of 75KHz variation, and 66dBuV for the output level.
- (2) Check that the test point voltage is about 400mV.

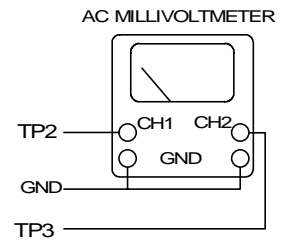

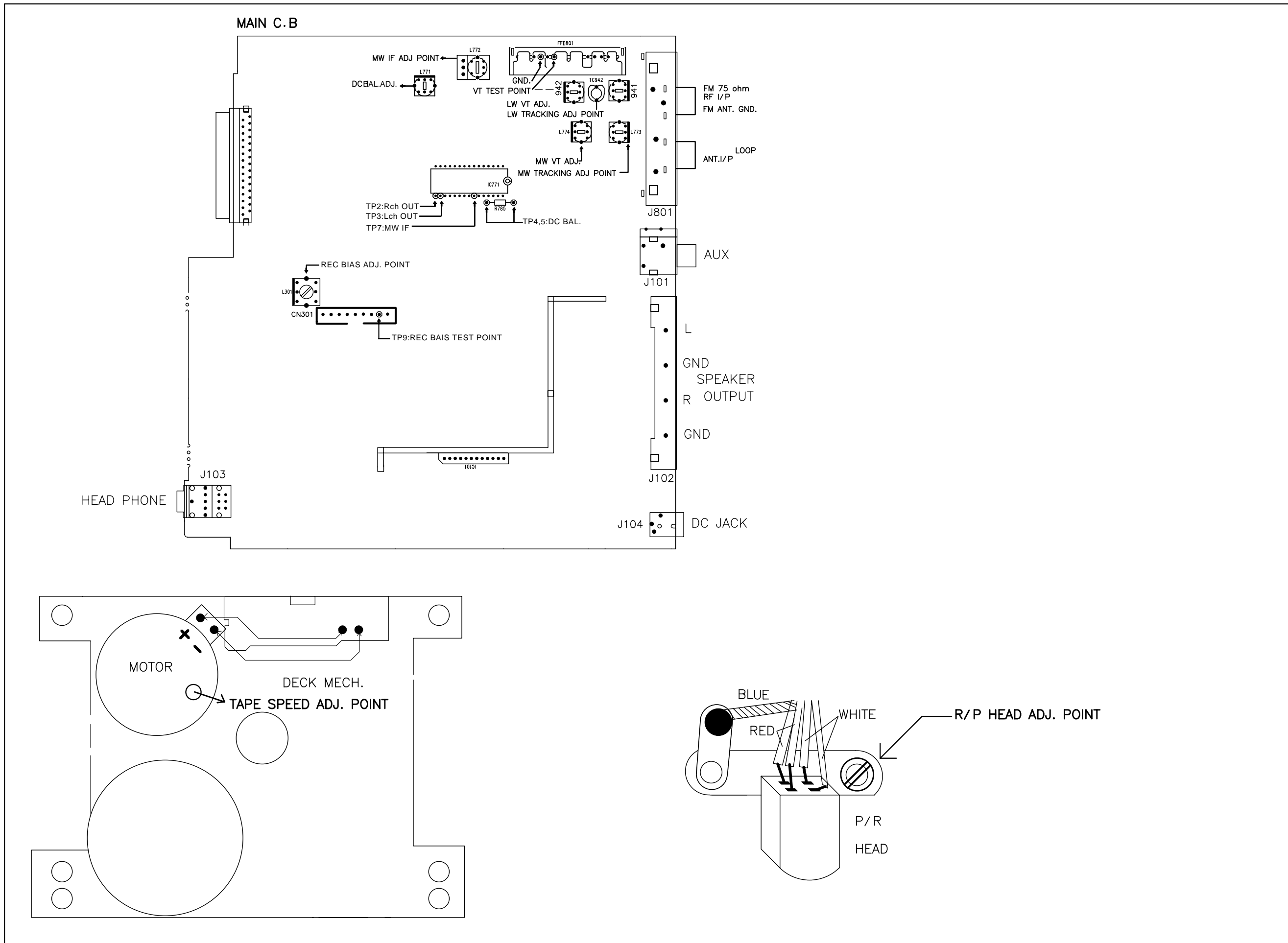

ELECTRICAL ADJUSTMENT (101K,EZ 131EZ MODEL)

DECK ADJUSTMENT

1.TAPE SPEED ADJUSTMENT

Requirements

- Measuring equipments : wow-flutter meter (frequency counter)

Test Tape: TTA-100 (3KHz)

Test point: HP OUT

Adjustment point : Tape speed adjustment point (motor)

- 1) Connect HP OUT to the Wow - flutter meter.
- 2) Insert the test tape (TTA-100), play back center of the tape and adjust the motor until it becomes $3,000\text{Hz} \pm 30\text{Hz}$.

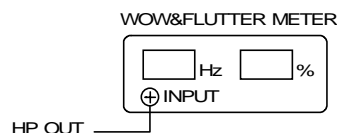

2.WOW – FLUTTER CHECK

Requirements

Test tape: TTA-100 (3KHz)

Test point: HP OUT

- 1) Connect the HP OUT to the Wow – flutter meter.
- 2) Set the indicator to JIS and the mode to W RMS (WTD) of the Wow – flutter meter.
- 3) Play back the center of the test tape (TTA-100) and check that it is below 0.35%.

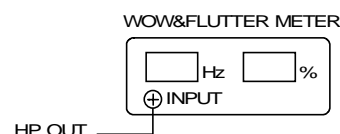

3.HEAD AZIMUTH ADJUSTMENT

Requirements

- Measuring equipment: Oscilloscope

Test Tape: TTA-330 (8KHz)

Test point: HP OUT

Adjustment point: Head azimuth screw

- 1) Connect the HP OUT to the oscilloscope of CH1 and CH2.
- 2) Set the V mode of the oscilloscope to ADD.
- 3) Insert the test tape (TTA-330) , play back the center of the tape and adjust the head azimuth screw until the waveform of the oscilloscope has reached the maximum when playing back at 10KHz.
- 4) After the adjustment, bond lock (1600B) the screw.

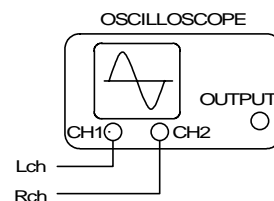

4.REC. BIAS FREQUENCY ADJUSTMENT

Requirement

- Measuring equipment: frequency counter

Test point: TP9

- 1) Connect the TP9 to the frequency counter.
- 2) Set the recording condition to the main unit.
- 3) Adjust the L301 until it becomes $85\text{KHz} \pm 5\text{KHz}$.

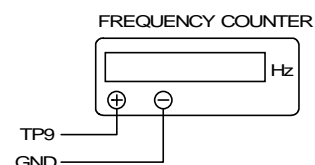

TUNER ADJUSTMENT

1 . VT ADJUSTMENT (LW)

Requirement

Measuring equipment: Digital multi-meter

Test point: TP1(FFE801 pin),GND

Adjustment point: L942

- (1) Adjust the reception frequency of the main unit to 290KHz.
- (2) Adjust L942 until the test point voltage (VT) is $5.5V \pm 0.1V$.
- (3) Adjust the reception frequency of the main unit to 144KHz.
- (4) Check that the test point (VT) voltage is below 2.5V.

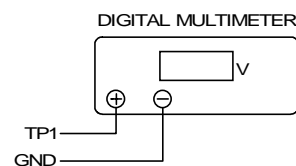

2 . VT ADJUSTMENT (MW)

Requirement

Measuring equipment: Digital multi-meter

Test point: TP1(FFE801 pin),GND

Adjustment point: L774

- (1) Adjust the reception frequency of the main unit to 1602KHz.
- (2) Adjust L773 until the test point voltage (VT) is $5.5V \pm 0.1V$.
- (3) Adjust the reception frequency of the main unit to 531KHz.
- (4) Check that the test point (VT) voltage is below 2.0V.

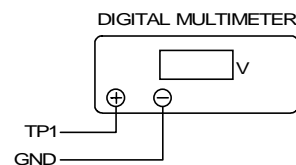

3 . VT CHECK (FM)

Requirement

Measuring equipment: Digital multi-meter

Test point: TP1(FFE801 pin),GND

- (1) Adjust the reception frequency of the main unit to 108.0MHz.
- (2) Check that the test point (VT) voltage is about 8.0V.
- (3) Adjust the reception frequency of the main unit to 87.5MHz.
- (4) Check that the test point (VT) voltage is about 2.5V.

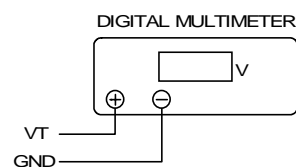

4 . DC BALANCE ADJUSTMENT

Requirement

Measuring equipment: Digital multi-meter

Test point: TP4, 5

Adjustment point: L771

- (1) Adjust the reception frequency of the main unit to 98.0MHz.
- (2) Adjust L771 until the test point voltage difference between TP4 and TP5 is $0mV \pm 20mV$.

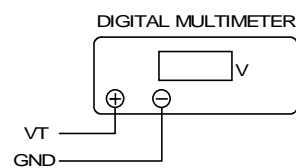

< MW / LW ADJUSTMENT >

For MW / LW adjustment, do wiring and connection as in the following.

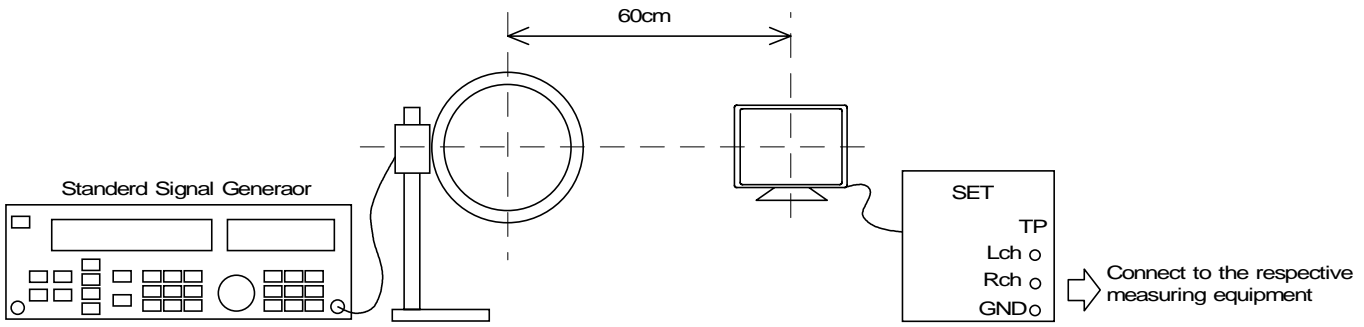

5 . IF ADJUSTMENT (MW)

Requirement

Measuring equipment: Oscilloscope or Millivoltmeter

Test point: TP7 (IC771 24pin), GND

Adjustment point: L772

- (1) Adjust the setting of Standard Signal Generator (hereinafter S.S.G.) to 450KHz of 30% variation.
- (2) While looking at the waveform on the oscilloscope, reduce the output level all the way.
- (3) Adjust L772 until the waveform of the oscilloscope reaches the maximum.

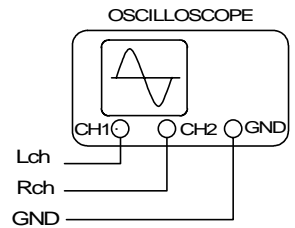

6 . TRACKING ADJUSTMENT (MW)

Requirement

Measuring equipment: Millivoltmeter

Test point: TP2, TP3, GND

Adjustment point: L773

- (1) Adjust the S.S.G. setting to 1000KHz of 30% variation and reduce the output level all the way.
- (2) Adjust the reception frequency of the main unit to 1000KHz.
- (3) Adjust L773 until the value of the millivoltmeter reaches the maximum.

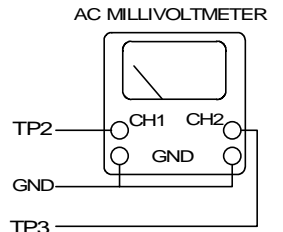

7 . TRACKING ADJUSTMENT (LW)

Requirement

Measuring equipment: Millivoltmeter

Test point: TP2, TP3, GND

Adjustment point: TC941, L941

- (1) Adjust the S.S.G. setting to 290KHz of 30% variation and reduce the output level all the way.
- (2) Adjust the reception frequency of the main unit to 290KHz.
- (3) Adjust LTC941 until the value of the millivoltmeter reaches the maximum.
- (4) Adjust the S.S.G. setting to 144KHz of 30% variation and reduce the output level all the way.
- (5) Adjust the reception frequency of the main unit to 144KHz.
- (6) Adjust LTC941 until the value of the millivoltmeter reaches the maximum.
- (7) Repeat the adjustment 2 to 3 times from 1 to 6 above.

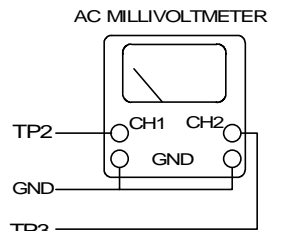

< FM ADJUSTMENT >

For adjusting FM, do wiring function and connection as in the following.

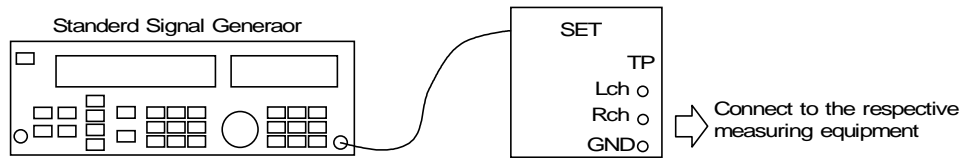

8 . TRACKING CHECK

Requirement

Measuring equipment: millivoltmeter

Test point: TP2, TP3, GND

- (1) Adjust the S.S.G. setting to 83.0MHz of 75KHz variation, and 66dBuV for the output level.
- (2) Check that the test point voltage is about 400mV.

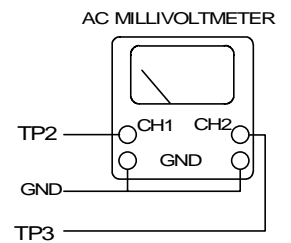

CD ADJUSTMENT

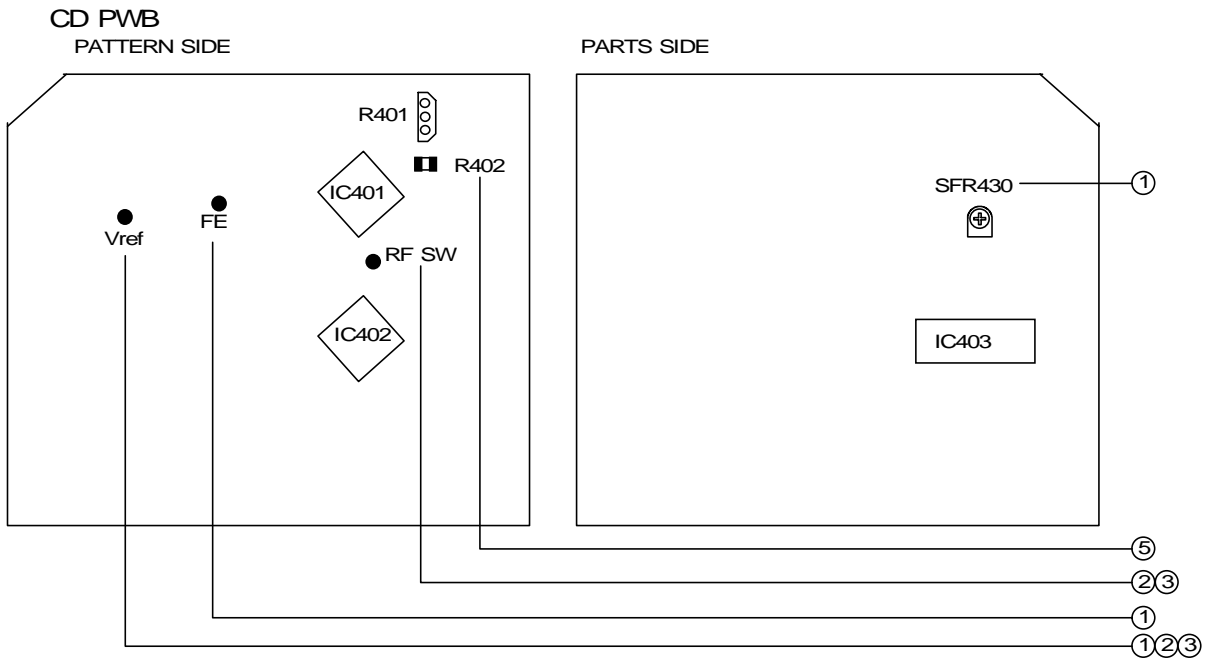

- Perform the adjustments after the main unit enters the test mode.
- Place the CD mechanism on level ground.
- Equipment and tools required

Measuring equipment

Digital multi-meter

Jitter meter (KIKUSUI 6235)

Test disc: TCD-782

ATD-001

1.FOCUS BAIS ADJUSTMENT

- 1) Connect the digital multi-meter to the test point FE and Vref.
- 2) Play back the 2nd track of TCD-782.
- 3) Adjust SFR430 until the digital multi-meter indicates $0 \pm 10\text{mV}$.

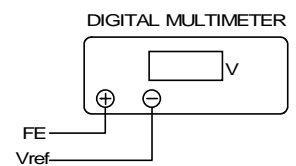

2.RF WAVEFORM CHECK

- 1) Connect oscilloscope to the test point RF SW and Vref.
- 2) Play back the 2nd track of TCD-782.
- 3) Check that the RF waveform has the maximum amplitude and the center of the wedge waveform has the clear blank.

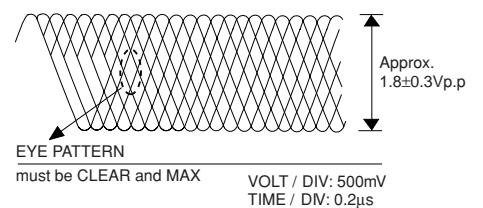
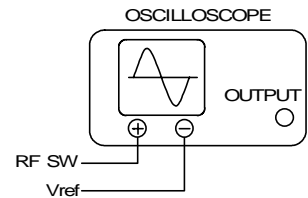

3. JITTER CHECK

- 1) While oscilloscope is kept connected in the same test point as in step 2. RF WAVEFORM CHECK, connect the output terminal of an oscilloscope to the input terminal of the jitter meter.
- 2) Set the VOLT range selector of oscilloscope to 500mV range or below.
- 3) Play back 2nd track of TCD-782.
- 4) Check that jitter meter indicates 28.0ns or less.

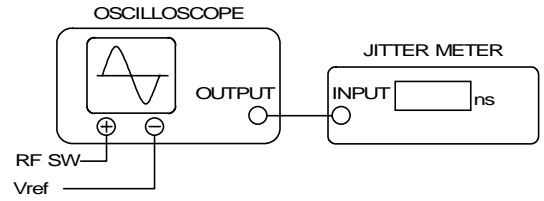

4. PLAY ABILITY CHECK

- 1) Play back the 3rd, 8th and 13th track of ATD-001. Check that the noise does not occur sound skipping does not occur.

5. LASER CURRENT CHECK

*Do not perform this measurement unless the laser is suspected to be defective.

- 1) Connect digital multi-meter across the resistor R402(10 Ω).
- 2) Play back the TCD-782 and check the DC voltage value on the digital multi-meter.
- 3) Calculate the laser current (Iop) by dividing the DC voltage across R402 by the resistor value (R402= 10 Ω). Check that the laser current (Iop) is 60mA or less.

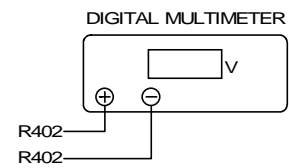

CD TEST MODE

1. How to Start the CD Test Mode

While pressing the CD FUNCTION button, insert the AC plug to the power outlet.
When the test mode started, all lights on the display are lit.

2. How to Exit the CD Test Mode

Press the POWER button or press the other FUNCTION buttons or disconnect the AC plug.

3. Function and Usage of the CD Test Mode

No	Mode	Button for Activation	Display	Operation	Contents
1	Start Mode		All lights are lit.		<ul style="list-style-type: none"> • FL check • Microcomputer check
2	Search Mode (without disc)	PLAY button	Normal	<ul style="list-style-type: none"> • LD illuminates all the time • Focus search continues operations *1 • Spindle motor continuous kick 	<ul style="list-style-type: none"> • APC circuit check • Laser current measurement • Focus search waveform check • Focus error waveform check (DRF in the search mode is ignored)
3	Play Mode	PLAY button	Normal	<ul style="list-style-type: none"> • Normal playback • If TOC cannot be read, focus search is continued 	<ul style="list-style-type: none"> • Each servo circuit is checked • DRF check
4	Sled Mode	FF button		<ul style="list-style-type: none"> • Pickup moves to the inner circumference *2 	<ul style="list-style-type: none"> • Sled circuit check • Mechanism operation check • Pickup check
		RWD button		<ul style="list-style-type: none"> • Pickup is moves to the outer circumference *2 	

* 1. The driver IC heats up and the protection circuit starts working when the focus search is continued for 10 minutes or longer. There can be a case that operations cannot be performed correctly. In such a case, turn off the main power. After cooling down the machine, restart the machine.

* 2. Be careful not to damage the gear because the sled motor rotates while the FF or RWD button is being pressed even if the pickup is located in the innermost track or the outermost track.

IC BLOCK DIAGRAM-1/3
IC, BU1920FS

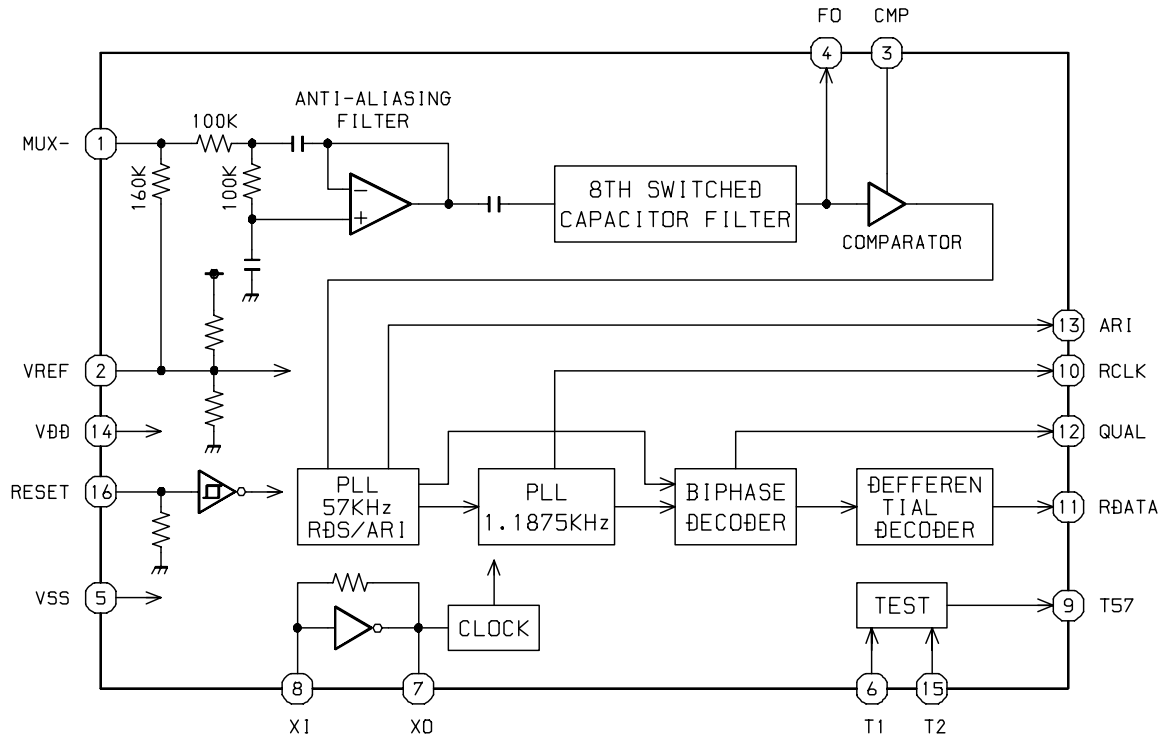

IC, M61509FP

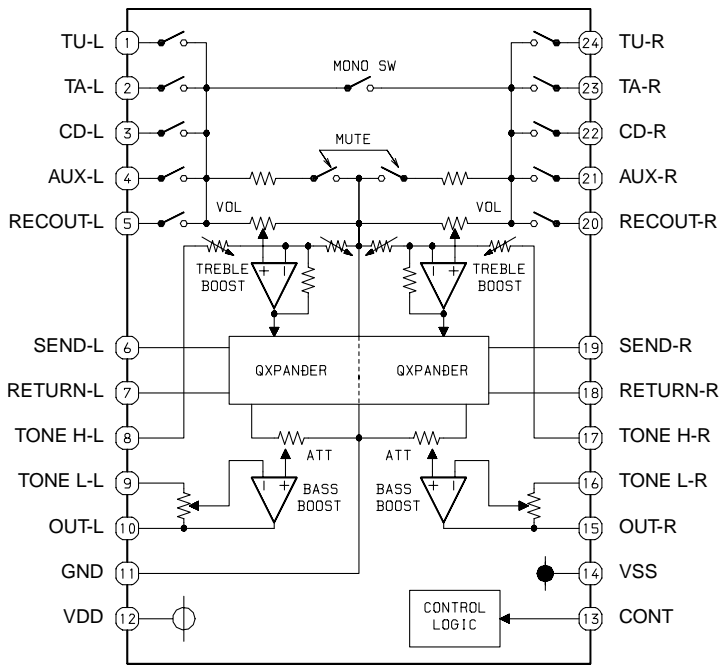

IC, M62495AFP

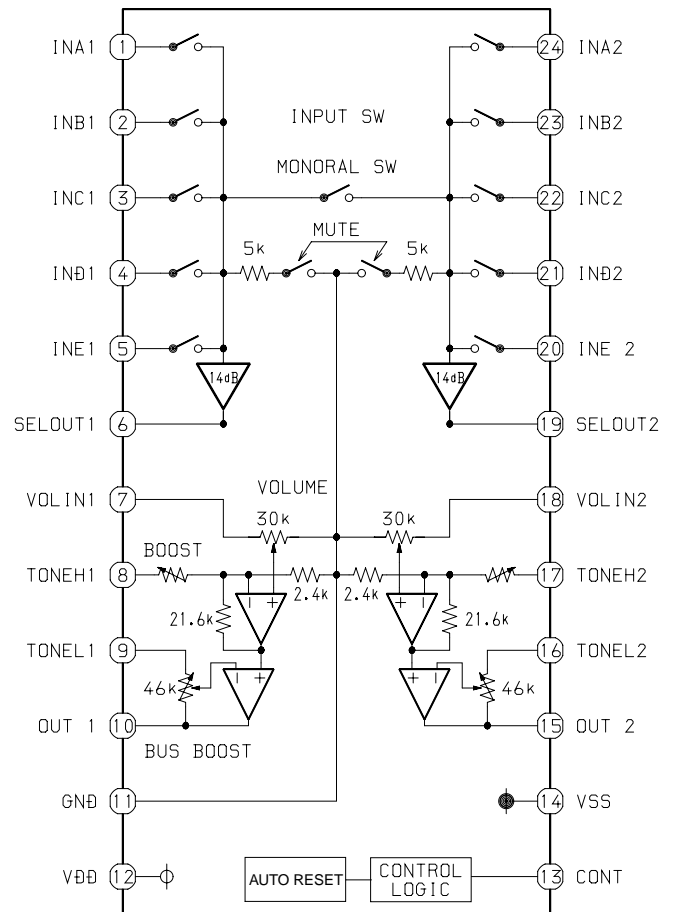

IC BLOCK DIAGRAM-2/3
IC, LC72131D

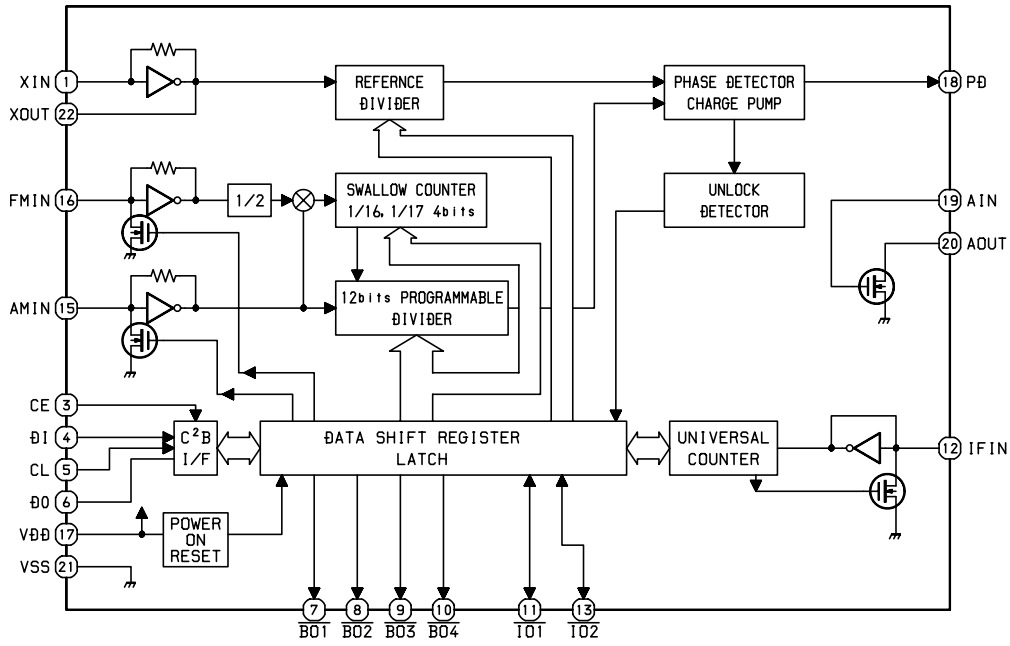

IC, LA1837NL

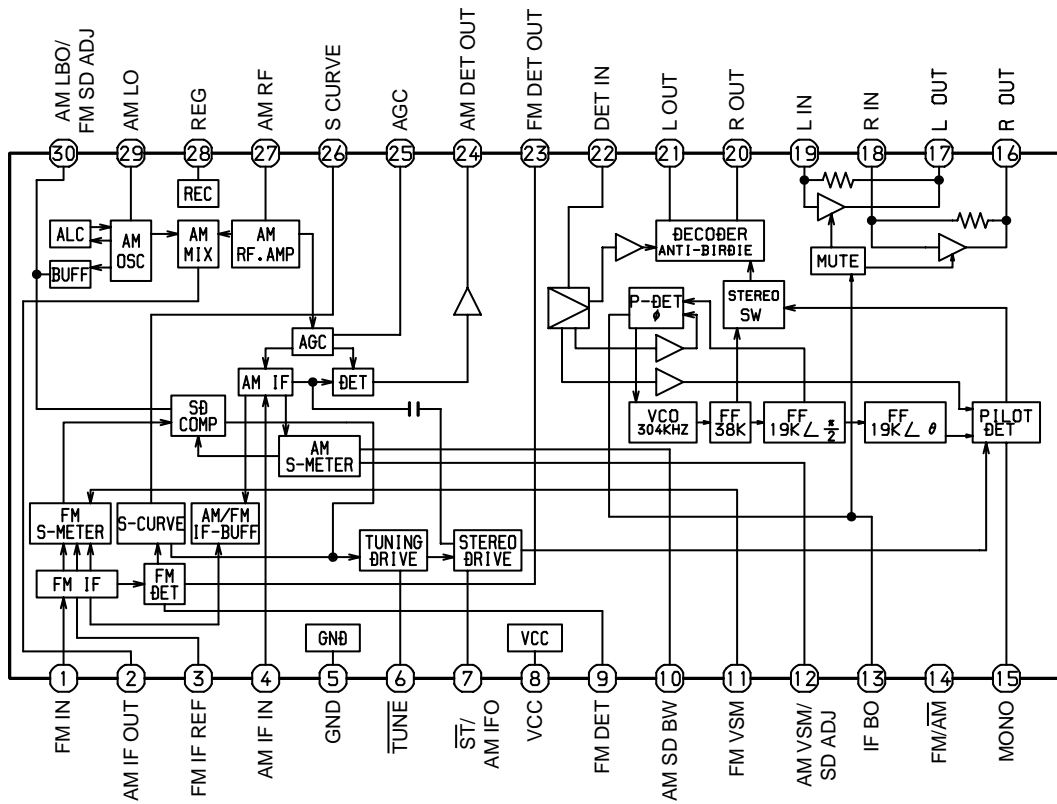

IC BLOCK DIAGRAM-3/3
IC, LA6541D

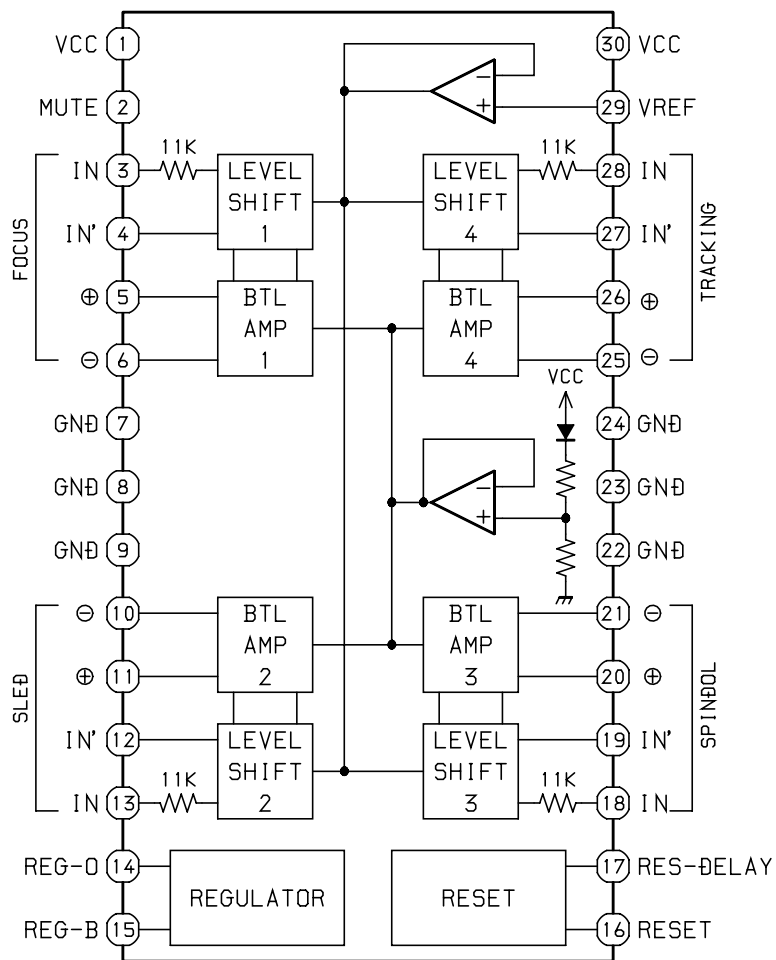

IC DESCRIPTION-1/3 (LA9241ML)-1/2

Pin No.	Pin Name	I/O	Description
1	FIN2	I	Pin to which external pickup photo diode is connected. RF signal is created by adding with the FIN1 pin signal. FE signal is created by subtracting from the FIN1 pin signal.
2	FIN1	I	Pin to which external pickup photo diode is connected.
3	E	I	Pin to which external pickup photo diode is connected. TE signal is created by subtracting from the F pin signal.
4	F	I	Pin to which external pickup photo diode is connected.
5	TB	I	DC component of the TE signal is input.
6	TE-	I	Pin to which external resistor setting the TE signal gain is connected between the TE pin.
7	TE	O	TE signal output pin.
8	TESI	I	TES "Track Error Sense" comparator input pin. TE signal is passed through a band-pass filter then input.
9	SCI	I	Shock detection signal input pin.
10	TH	I	Tracking gain time constant setting pin.
11	TA	O	TA amplifier output pin.
12	TD-	I	Pin to which external tracking phase compensation constants are connected between the TD and VR pins.
13	TD	I	Tracking phase compensation setting pin.
14	JP	I	Tracking jump signal (kick pulse) amplitude setting pin.
15	TO	O	Tracking control signal output pin.
16	FD	O	Focusing control signal output pin.
17	FD-	I	Pin to which external focusing phase compensation constants are connected between the FD and FA pins.
18	FA	I	Pin to which external focusing phase compensation constants are connected between the FD- and FA- pins.
19	FA-	I	Pin to which external focusing phase compensation constants are connected between the FA and FE pins.
20	FE	O	FE signal output pin.
21	FE-	I	Pin to which external FE signal gain setting resistor is connected between the FE pin.
22	AGND	—	Analog signal GND.
23	SP	—	Single ended output of the CV+ and CV- pin input signal.
24	SP-	O	Spindle amp input.
25	SPG	I	Pin to which external spindle gain setting resistor in 12 cm mode is connected.
26	SP-	I	Pin to which external spindle phase compensation constants are connected together with SPD pin.
27	SPD	O	Spindle control signal output pin.
28	SLEQ	I	Pin to which external sled phase compensation constants are connected.
29	SLD	O	Sled control signal output pin.
30, 31	SL-, SL+	I	Sled advance signal input pin from microprocessor.
32, 33	JP-, JP+	I	Tracking jump signal input pin from DSP.
34	TGL	I	Tracking gain control signal input from DSP. Low gain when TGL = H.
35	TOFF	I	Tracking off control signal input pin from DSP. Off when TOFF = H.

IC DESCRIPTION-1/3 (LA9241ML)-2/2

Pin No.	Pin Name	I/O	Description
36	TES	O	Pin from which TES signal is output to DSP.
37	HFL	O	“High Frequency Level” is used to judge whether the main beam position is on top of bit or on top of mirror.
38	SLOF	I	Sled servo off control input pin.
39, 40	CV-, CV+	I	CLV error signal input pin from DSP.
41	RFSM	O	RF output pin.
42	RFS-	I	RF gain setting and EFM signal 3T compensation constant setting pin together with RFSM pin.
43	SLC	O	“Slice Level Control” is the output pin which controls the RF signal data slice level by DSP.
44	SLI	I	Input pin which control the data slice level by the DSP.
45	DGND	—	Digital system GND.
46	FSC	O	Output pin to which external focus search smoothing capacitor is connected.
47	TBC	I	“Tracking Balance Control” EF balance variable range setting pin.
48	NC	—	No connection.
49	DEF	O	Disc defect detector output pin.
50	CLK	I	Reference clock input pin. 4.23 MHz of the DSP is input.
51	CL	I	Microprocessor command clock input pin.
52	DATA	I	Microprocessor command data input pin.
53	CE	I	Microprocessor command chip enable input pin.
54	DRF	O	“Detect RF” RF level detector output.
55	FSS	I	“Focus Search Select” focus search mode (\pm search/+ search) select pin.
56	VCC2	—	Servo system and digital system Vcc pin.
57	REFI	—	Pin to which external bypass capacitor for reference voltage is connected.
58	VR	O	Reference voltage output pin.
59	LF2	I	Disc defect detector time constant setting pin.
60	PH1	I	Pin to which external capacitor for RF signal peak holding is connected.
61	BH1	I	Pin to which external capacitor for RF signal bottom holding is connected.
62	LDD	O	APC circuit output pin.
63	LDS	I	APC circuit input pin.
64	VCC1	—	RF system Vcc pin.

IC DESCRIPTION-2/3 (LC78622NE)-1/2

Pin No.	Pin Name	I/O	Description	
1	DEFI	I	Defect sense signal (DEF) input pin. (Connect to 0V when not used)	
2	TAI	I	For PLL.	Test signal input pin with built-in pull-down resistor. Be sure to connect to 0V.
3	PDO	O		Phase comparator output pin to control external VCO.
4	VVSS	—		GND pin for built-in VCO. Be sure to connect to 0V.
5	ISET	I		Pin to which external resistor adjusting the PDO output current.
6	VVDD	—		Power supply pin for built-in VCO.
7	FR	I		Pin for VCO frequency range adjustment.
8	VSS	—	Digital system GND. Be sure to connect to 0V.	
9	EFMO	O	For slice level control.	EFM signal output pin.
10	EFMIN	I		EFM signal input pin.
11	TEST2	I	Test signal input pin with built-in pull-down resistor. Be sure to connect to 0V.	
12, 13	CLV+, CLV-	O	Disc motor control output. Three level output is possible using command.	
14	V/P	O	Rough servo or phase control automatic selection monitoring output pin. Rough servo at H. Phase servo at L.	
15	HFL	I	Track detect signal input pin. Schmidt input.	
16	TES	I	Tracking error signal input pin. Schmidt input.	
17	TOFF	O	Tracking OFF output pin.	
18	TGL	O	Tracking gain selection output pin. Gain boost at L.	
19, 20	JP+, JP-	O	Track jump control signal output pin. Three level output is possible using command.	
21	PCK	O	EFM data playback clock monitoring pin 4.3218 MHz when phase is locked in.	
22	FSEQ	O	Sync signal detection output pin. H when the sync signal which is detected from EFM signal and thesync signal which is internally generated agree. (Not connected)	
23	VDD	—	Digital system power supply pin.	
24	SL+	I/O	General purpose input/output pin 1 to 5.	The pin is controlled by the serial data command from microprocessor. When the pin is not used, set the pin to the input terminal and connect to 0V, or alternately set the pin to output terminal and leave the pin open.
25	SL-	I/O		
26	CONT3	I/O		
27	PUIN	I/O		
28	RW	I/O		
29	EMPH	O	De-emphasis monitor output pin. De-emphasis disc is being played back at H. (Not connected)	
30	C2F	O	C2 flag output pin. (Not connected)	
31	DOUT	O	DIGITAL OUT output pin. (EIAJ format)	
32, 33	TEST3, TEST4	I	Test signal input pin with built-in pull-down resistor. Be sure to connect to 0V.	
34	NC	—	Not used. Set the pin to open.	
35	MUTEL	O	L-channel 1-bit DAC.	L-channel mute output pin. (Not connected)
36	LVDD	—		L-channel power supply pin.
37	LCHO	O		L-channel output pin.
38	LVSS	—		L-channel GND. Be sure to connect to 0V.
39	RVSS	—	R-channel 1-bit DAC.	R-channel GND. Be sure to connect to 0V.
40	RCHO	O		R-channel output pin.
41	RVDD	—		R-channel power supply pin.
42	MUTER	O		R-channel mute output pin. (Not connected)

IC DESCRIPTION-2/3 (LC78622NE)-2/2

Pin No.	Pin Name	I/O	Description
43	XVDD	—	Crystal oscillator power supply pin.
44	XOUT	O	Pin to which external 16.9344 MHz crystal oscillator is connected.
45	XIN	I	
46	XVSS	—	Crystal oscillator GND pin. Be sure to connect to 0V.
47	SBSY	O	Subcode block sync signal output pin. (Not connected)
48	EFLG	O	C1, C2, single and dual correction monitoring pin. (Not connected)
49	PW	O	Subcode P, Q, R, S, T, U and W output pin. (Not connected)
50	SFSY	O	Subcode frame sync signal output pin. Falls down when subcode enters standby. (Not connected)
51	SBCK	I	Subcode read clock input pin. Schmidt input. (Be sure to connected to 0V when not in use)
52	FSX	O	Pin outputting the 7.35 kHz sync signal which is generated by dividing frequency of crystal oscillator. (Not connected)
53	WRQ	O	Subcode Q output standby output pin.
54	RWC	I	Read/write control input pin. Schmidt input.
55	SQOUT	O	Subcode Q output pin.
56	COIN	I	Command input pin from microprocessor.
57	\overline{CQCK}	I	Command input read clock or subcode read input clock from SQOUT pin
58	\overline{RES}	I	LC78622 reset input pin. Set this pin to L once when the main power is turned on.
59	TST11	O	Test signal output pin. Use this pin as open (normally L output). (Not connected)
60	16M	O	16.9344 MHz output pin. (Not connected)
61	4.2M	O	4.2336 MHz output pin.
62	TEST5	I	Test signal input pin with built-in pull-down resistor. Be sure to connect to 0V.
63	\overline{CS}	I	Chip select signal input pin with built-in pull-down resistor. Be sure to connect to 0V while it is not controlling.
64	TEST1	I	Test signal input pin without built-in pull-down resistor. Be sure to connect to 0V.

Note: The same potential must be applied to the respective power supply terminals. (VDD, VVDD, LVDD, RVDD, XVDD)

IC DESCRIPTION-3/3 (LC867248A-5T90)-1/2

Pin No.	Pin Name	I/O	Description
1	O-SCONTM	O	M62495AFP control. Open drain output.
2	O-SCONTL	O	
3	O-TUDI	O	Tuner data output. CMOS output.
4	I-TUDO	I	Tuner data input. Open drain input.
5	O-TUCL	O	Tuner clock output. CMOS output.
6	O-COIN	O	CD control. CMOS output.
7	I-SQOUT	I	CD control. Open drain input.
8	O-CQCK	O	CD control. CMOS output.
9	O-RWC	O	
10	O-CLKSFT	O	Clock shift output. "L" during shift. open drain output.
11	I-TMBASE	I	8 Hz time base input.
12	I-RESET	I	Reset input. "L" during reset.
13, 14	XT1,XT2	I/O	32.768kHz crystal.
15	VSS1	—	GND.
16, 17	CF1, CF2	I/O	Main clock 5.76 MHz.
18	VDD1	—	+5V.
19	I-KEY0	I	KEY0 A/D input.
20	I-KEY1	I	KEY1 A/D input.
21	I-RDSIG	I	RDS signal level input. (A/D input)
22	I-WRQ	I	CD control input.
23	I-DRF	I	
24	I-DOOR	I	CD door SW detection SW input. "L" during CLOSE.
25	NC	I	Not used.
26	I-SWTAPE	I	Tape detection SW input. (A/D input)
27	I-STEREO	I	Monaural/stereo indication selector input. "L" during stereo.
28	I-RDCL	I	RDS clock input.
29	I-RMT	I	Remote control input. (fall-down edge interrupt input)
30	I-HOLD	I	Hold mode detection. "L" during hold mode.
31	I-RDDT	I	RDS data input.
32	NC	I	Not used.
33	NC	I	Not used.
34	O-MOTOR	O	Mechanism deck motor ON/OFF output. "H" during ON. CMOS output.
35	O-PL	O	Mechanism deck plunger solenoid ON/OFF output. "H" during ON. CMOS output .
36-38	NC	O	Not used.
39-55	S9-S25	O	LCD SEG terminal Initial setting output. (S10 to S17)
56	VDD2	—	+5V.
57	VSS2	—	GND.
58-79	S26-S47	—	LCD SEG terminal .
80	I-CLKDSP	I	Watch indication select input "L": 12H. "H": 24H.
81	I-AS	I	Auto stop. counter input .
82	I-STOP	I	Tape stop input. "L" during STOP.

IC DESCRIPTION-3/3 (LC867248A-5T90)-2/2

Pin No.	Pin Name	I/O	Description
83-86	COM0-COM3	O	LCD common output.
87	I-INIT	I	Initial setting input.
88	I-AC/DC	I	AC/DC detection. "H" during AC. COMS input.
89	VSS3	—	GND.
90	VDD3	—	5V.
91	NC	—	Not used.
92	O-TUCE	O	Tuner chip enable output. CMOS output .
93	O-CD-ON	O	"H" output during CD function. CMOS output.
94	O-TU-ON	O	"H" output during TU function. CMOS output.
95	O-RMT	O	REC mute output. "H" during mute. CMOS output.
96	O-REC/PB	O	REC/PB select output. "L" during PB. COMS output.
97	O-MUTE	O	Mute output. "H" during mute. COMS output.
98	O-PCONT	O	Power control output. "H" during ON. CMOS output.
99	O-BIAS	O	REC bias ON/OFF output. "H" at ON. Open drain output.
100	NC	O	Not used.

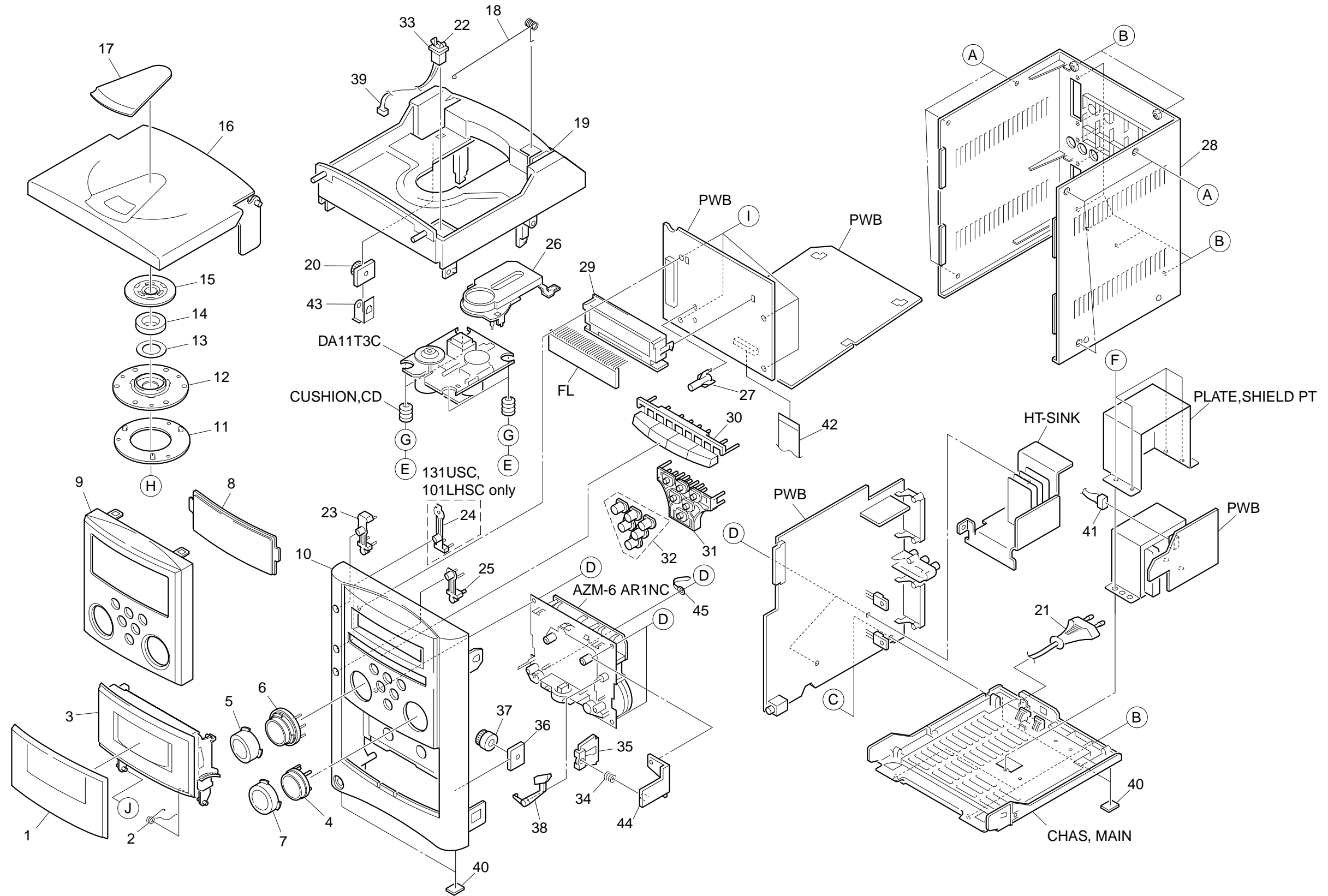

MECHANICAL PARTS LIST-1/1

REF. NO	PART NO.	KANRI NO.	DESCRIPTION	REF. NO	PART NO.	KANRI NO.	DESCRIPTION
1	8B-CLM-001-010		LID,CASS<101LHSC>	25	8B-CLB-016-010		KEY,TIMER
1	8B-CLB-006-010		LID,CASS<131USC>	26	8Z-CDB-169-010		PANEL,CD SANYO
1	8B-CLB-044-010		LID,CASS E<131EZSC>	27	8B-CLB-018-010		HLD,KEY EQ
1	8B-CLM-024-010		LID,CASS E (21)<101KSC,101EZSC>	28	8B-CLB-033-010		CABI,REAR EZ<EXCEPT 131USC,101LHSC>
2	8Z-CL8-209-010		SPR-T,CASS	28	8B-CLB-037-010		CABI,REAR H<101LHSC>
3	8B-CLB-007-010		BOX,CASS<131USC,101LHSC>	28	8B-CLB-036-010		CABI,REAR U<131USC>
3	8B-CLB-045-010		BOX,CASS E<131EZSC>	29	8Z-CL8-201-010		GUIDE,LCD
3	8B-CLM-025-010		BOX,CASS E (21)<101KSC,101EZSC>	30	8B-CLB-008-010		KEY,FUNC<131USC,101LHSC>
4	8B-CLB-010-010		KEY,VOLUME	30	8B-CLB-046-010		KEY,FUNC E<131EZSC>
5	8B-CLB-011-010		CAP, EQ<131USC>	30	8B-CLM-026-010		KEY,FUNC E (21)<101KSC,101EZSC>
5	8B-CLM-021-010		CAP, EQ (21)<EXCEPT 131USC,131EZSC>	31	8B-CLB-013-010		KEY,CONTROL CD
5	8B-CLA-008-010		CAP, EQ RDS<131EZSC>	32	8B-CLB-014-010		CAP, CONTROL CD SET
6	8B-CLB-009-010		KEY,EQ	33	87-064-108-110		HLD,NC LUTCH
7	8B-CLB-012-010		CAP, VOLUME<131USC,131EZSC>	34	82-NF5-228-010		SPR-C,LOCK
7	8B-CLM-020-010		CAP, VOLUME (21)<EXCEPT 131USC,131EZSC>	35	82-NF5-229-010		PLATE,LOCK
8	8B-CLA-003-010		WINDOW,DISPLAY	36	84-CD5-216-010		BRACKET
9	8B-CLB-005-010		PANEL,FRONT<131USC,101LHSC>	37	84-CD5-215-010		GEAR
9	8B-CLM-023-010		PANEL,FRONT E (21)<101KSC,101EZSC>	38	88-CL5-203-010		LEVER,CASS LOCKE R
9	8B-CLB-024-010		PANEL,FRONT RDS<131EZSC>	39	8B-CLA-606-010		CONN ASSY,2P CD DOOR
10	8B-CLB-001-010		CABI,FR<131USC,101LHSC>	40	8Z-CL8-204-010		CUSH,FOOT
10	8B-CLB-019-010		CABI,FRONT A<131EZSC>	41	8Z-CL8-691-010		F-CABLE,3P 2.5 180MM<131USC>
10	8B-CLM-022-010		CABI,FRONT E (21)<101KSC,101EZSC>	42	88-907-121-110		FF-CABLE, 7P 1.25 120MM
11	8Z-CH4-212-110		RING,CHUCK	43	8Z-CL8-214-010		DMPR,HLD, BE
12	8Z-CH4-211-110		BASE,CHUCK	44	88-CL5-202-010		HLD,CASS LOCKE R
13	84-CD5-217-010		PLATE,MAGNET	45	87-064-185-010		HLD, WIRE
14	87-036-368-010		MAGNET	A	87-B10-239-010		QT2+3-8 W/O CR
15	8Z-CH4-225-210		HLD,CHUCK A(S)	B	87-B10-230-010		BVT2+3-10 W/O SLOT SILVER CR
16	8B-CLB-003-010		LID,CD	C	87-067-703-010		TAPPING SCREW, BVT2+3-10
17	8B-CLB-004-010		WINDOW,CD<131USC,101LHSC>	D	87-067-579-010		TAPPING SCREW, BVT2+3-8
17	8B-CLB-047-010		WINDOW,CD E<131EZSC>	E	87-342-074-010		UT2+2.6-8
17	8B-CLM-027-010		WINDOW,CD E (21)<101KSC,101EZSC>	F	87-761-096-410		VFT2+3-10 GLD<EXCEPT 131USC,131EZSC>
18	8Z-CL8-205-010		SPR-T,CD	F	87-761-097-410		VFT2+3-10 GLD<131USC,131EZSC>
19	8B-CLB-002-010		CHAS,CD	G	8Z-CL8-220-010		W,30-0856-01-01-01
20	8Z-NF6-210-010		DMPR,150 N	H	87-571-033-410		TAPPING SCREW, VIT+2-4
21	87-A80-157-010		AC CORD ASSY,E BLK CC<EXCEPT 131USC>	I	87-751-095-410		VT2+3-8 W/O
21	87-A80-110-010		AC CORD ASSY,U SPT-2W<131USC>	J	8B-CLB-204-010		W, BOX CASS
22	87-036-389-010		SW,PUSH LOCK				
23	8B-CLB-015-010		KEY,POWER				
24	8B-CLB-017-010		KEY,Q-SOUND<131USC,101LHSC>				

COLOR NAME TABLE

Basic color symbol	Color	Basic color symbol	Color	Basic color symbol	Color
B	Black	C	Cream	D	Orange
G	Green	H	Gray	L	Blue
LT	Transparent Blue	N	Gold	P	Pink
R	Red	S	Silver	ST	Titan Silver
T	Brown	V	Violet	W	White
WT	Transparent White	Y	Yellow	YT	Transparent Yellow
LM	Metallic Blue	LL	Light Blue	GT	Transparent Green
LD	Dark Blue	DT	Transparent Orange	GM	Metallic Green
YM	Metallic Yellow	DM	Metallic Orange	PT	Transparent Pink
LA	Aqua Blue	GL	Light Green		

TAPE MECHANISM EXPLODED VIEW-1/1 (AZM-6 AR1NC)

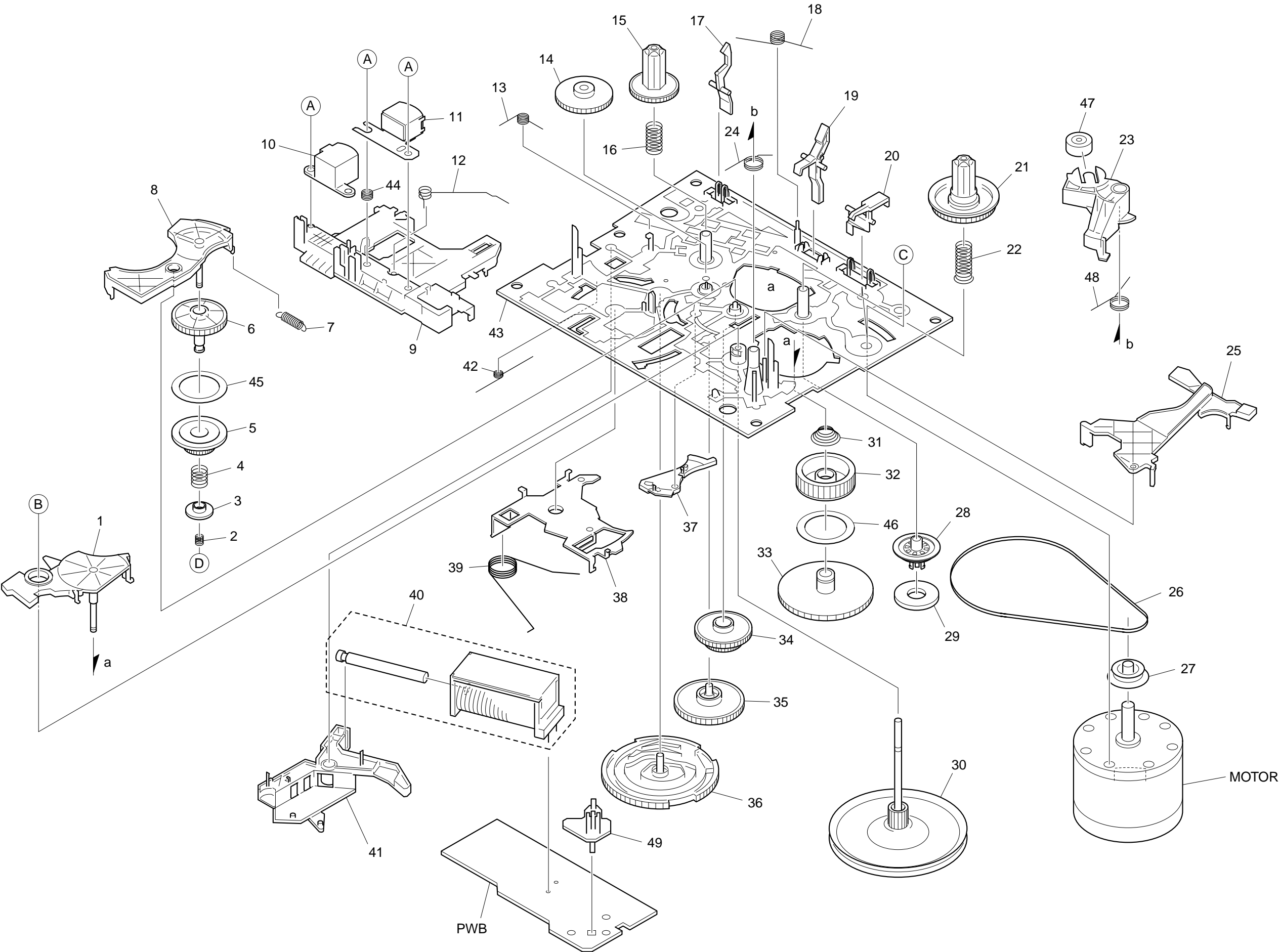

TAPE MECHANISM PARTS LIST-1/1 (AZM-6 AR1NC)

REF. NO	PART NO.	KANRI NO.	DESCRIPTION	REF. NO	PART NO.	KANRI NO.	DESCRIPTION
1	8Z-ZM3-216-210		LEVER, T-UP M3	26	8Z-ZM3-227-210		BELT, MAIN M3
2	8Z-ZM1-257-210		SPR-C, F/R	27	8Z-ZM1-271-010		PULLEY, MOT ZZM-1
3	8Z-ZM1-236-010		CLR, SLIP FF/REW	28	8A-ZM6-206-010		CLR, MG
4	8Z-ZM3-261-010		SPR-C, FR M3 C	29	82-ZM3-616-010		RING MAGNET 4
5	8Z-ZM3-250-010		GEAR, SLIP F/R A M3	30	8Z-ZM3-256-010		FLY-WHL ASSY, M3 R
6	8Z-ZM1-238-110		GEAR, SLIP FF/REW B 2	31	8Z-ZM1-251-310		SPR-C, T-UP SLIP
7	8Z-ZM3-263-010		SPR-E, FR C	32	8Z-ZM1-227-010		GEAR, SLIP T-UP A
8	8Z-ZM3-220-110		LEVER, FR M3	33	8Z-ZM1-228-010		GEAR, SLIP T-UP B
9	8Z-ZM3-205-110		LEVER, PLAY M3	34	8Z-ZM1-232-010		GEAR, IDL FF/REW
10	87-A90-404-010		HEAD, EH LE15B	35	8Z-ZM3-229-010		GEAR, IDL M3
11	87-A90-403-110		HEAD, RPH MS15R	36	8Z-ZM3-219-310		GEAR, CAM M3
12	8Z-ZM3-262-010		SPR-T, BRG M3 C	37	8Z-ZM3-209-010		LEVER, CAM FR
13	8Z-ZM3-236-310		SPR-T, PLAY M3	38	8Z-ZM3-243-110		LEVER ASSY, HD UP
14	8Z-ZM3-251-010		GEAR, IDL REW M3	39	8Z-ZM3-238-110		SPR-T, HD UP
15	8Z-ZM1-226-010		GEAR, REEL L	40	82-ZM3-628-010		SOL ASSY, 23 SO
16	8Z-ZM3-222-210		SPR-C, REEL L M3	41	8Z-ZM3-206-010		LEVER, TRIG
17	8Z-ZM1-240-110		LVR, REC (*)	42	8Z-ZM3-231-310		SPR-T, TRIG
18	8Z-ZM3-234-310		SPR-T, LVR CAS	43	8A-ZM6-201-110		CHAS ASSY, M6
19	8Z-ZM3-221-210		LEVER, CAS	44	84-ZM2-227-310		SPR-C, AZIMUTH
20	8A-ZM6-207-010		LEVER, STOP	45	8Z-ZM1-269-010		FELT, FF/REW 2
21	8Z-ZM1-225-110		GEAR, REEL R	46	8Z-ZM1-265-010		FELT, T-UP
22	8Z-ZM3-223-310		SPR-C, REEL R M3	47	8Z-ZM1-261-110		ROLLER ASSY, PINCH
23	8Z-ZM3-215-110		LEVER, PINCH M3	48	8Z-ZM3-252-010		SPR-T, PINCH 2
24	8Z-ZM3-264-010		SPR-T, T-UP M3 C	49	8A-ZM6-205-010		HLDR, IC
25	8A-ZM6-204-010		LEVER, EJECT	A	84-ZM2-252-010		S-SCREW, AZI-2-6.4 C
				B	8Z-ZM3-245-110		V+2.6 ZZM-3
				C	87-B10-301-010		W-L, 1.63-3.2-0.5 SLIT
				D	8Z-ZM1-275-010		W-L, 1.47-4-0.25

CD MECHANISM EXPLODED VIEW-1/1 (DA-11T3C)

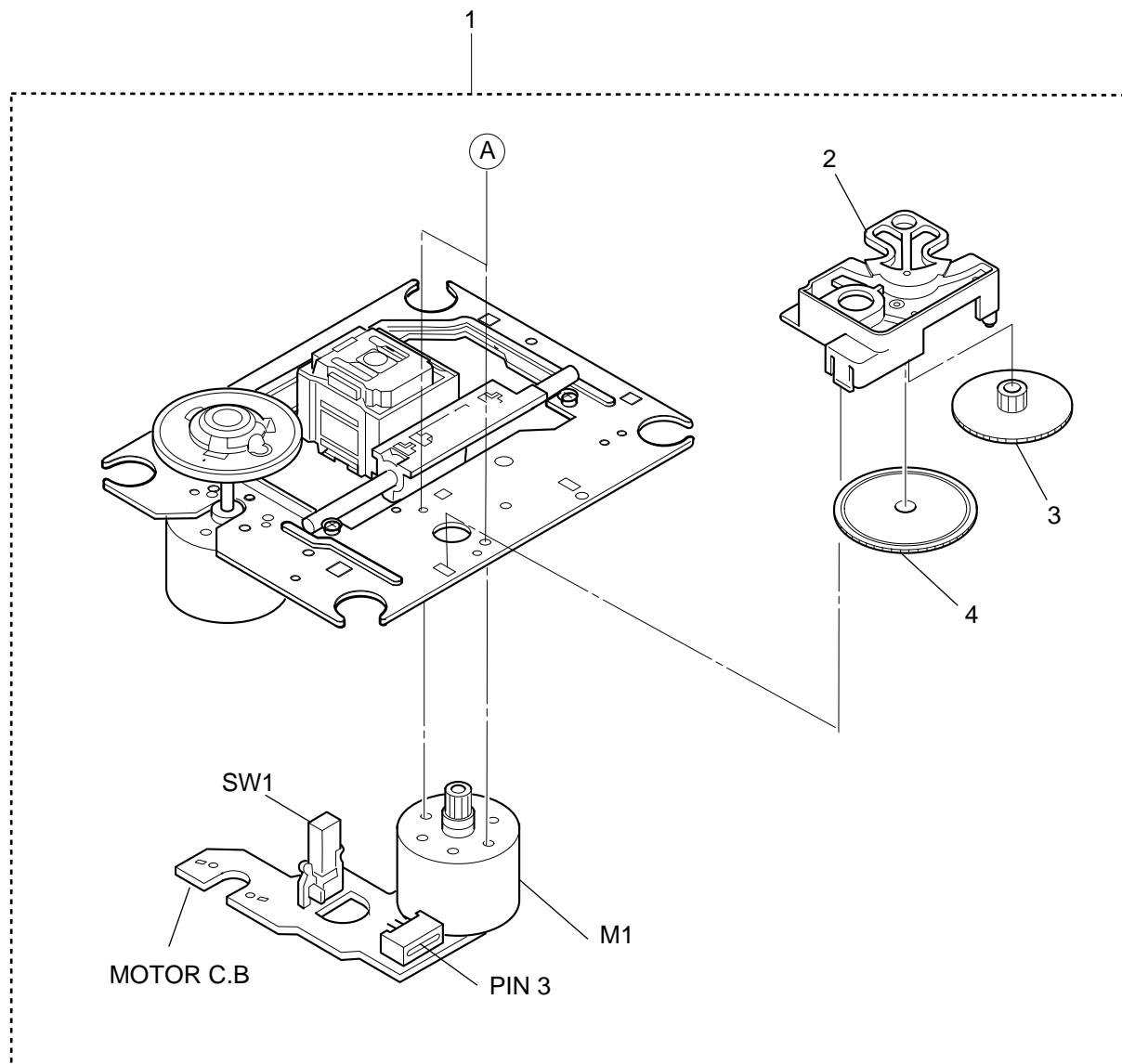

CD MECHANISM PARTS LIST-1/1 (DA-11T3C)

REF. NO	PART NO.	KANRI NO.	DESCRIPTION
1	M8-ZZK-E90-070		DA11T3C
2	S2-121-A28-400		COVER GEAR
3	S2-511-A21-000		GEAR MIDDLE
4	S2-511-A21-100		GEAR, DRIVE
A	S1-PN2-03R-OSE		SCR PAN PCS 2-3

SPEAKER DISASSEMBLY INSTRUCTIONS-1/1

Type.1

Insert a flat-bladed screwdriver into the position indicated by the arrows and remove the panel. Remove the screws of each speaker unit and then remove the speaker units.

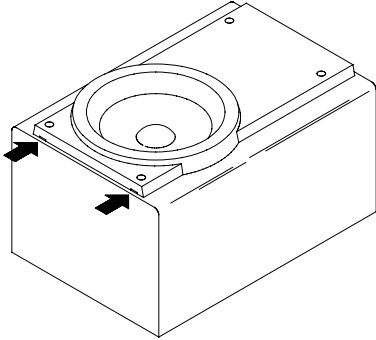

Type.2

Remove the grill frame and four pieces of rubber caps by pulling out with a flat-bladed screwdriver. Remove the screws from hold where installed rubber caps. Insert a flat-bladed screwdriver into the position indicated by the arrows and remove the panel. Remove the screws of each speaker unit and then remove the speaker units.

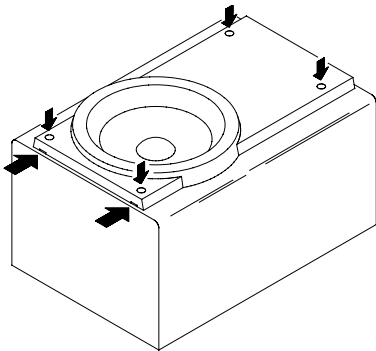

Type.3

Insert a flat-bladed screwdriver into the position indicated by the arrows and remove the panel. Turn the speaker unit to counterclockwise direction while inserting a flat-bladed screwdriver into one of the hollows around speaker unit, and then remove the speaker unit. After replacing the speaker unit, install it turning to clockwise direction until "click" sound comes out.

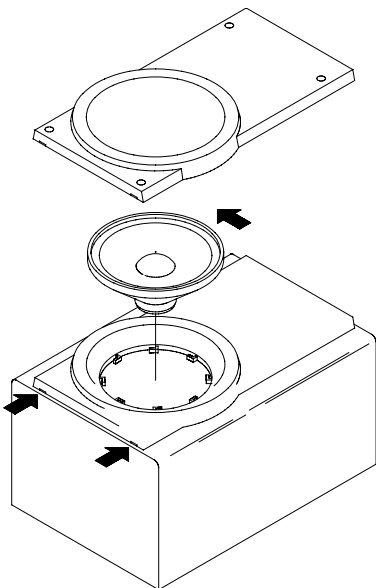

Type.4

TOOLS

- ① Plastic head hammer
- ② (⊖) flat head screwdriver
- ③ Cut chisel

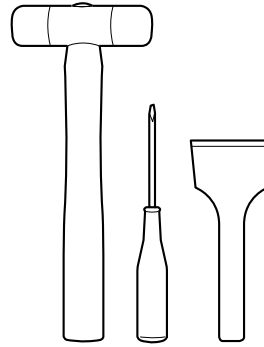

How to Remove the PANEL, FR

1. Insert the (⊖) flat head screwdriver tip into the gap between the PANEL, FR and the PANEL, SPKR. Tap the head of the (⊖) flat head screwdriver with the plastic hammer head, and create the clearance as shown in Fig-1.
2. Insert the cut chisel in the clearance, and tap the head of the cut chisel with plastic hammer as shown in Fig-2, to remove the PANEL, FR.
3. Place the speaker horizontally. Tap head of the cut chisel with plastic hammer as shown in Fig-3, and remove the PANEL, FR completely.

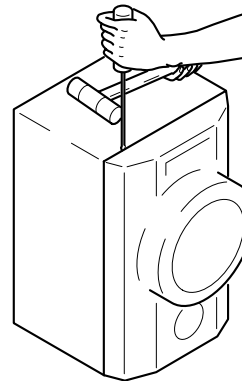

Fig-1

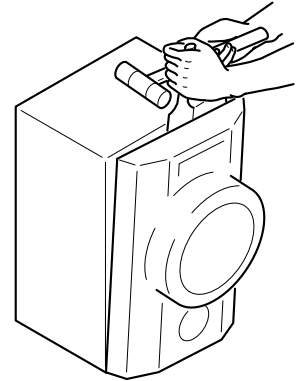

Fig-2

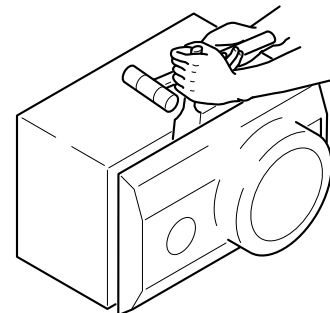

Fig-3

How to Attach the PANEL, FR

Attach the PANEL, FR to the PANEL, SPKR. Tap the four corners of the PANEL, FR with the plastic hammer to fit the PANEL, FR into the PANEL, SPKR completely.

SPEAKER PARTS LIST-1/1

REF. NO	PART NO.	KANRI NO.	DESCRIPTION
1	8B-CLB-020-010		CABI,FR SPKR
2	8B-CLB-021-010		CABI,REAR SPKR
3	8A-CLL-601-010		CORD ASSY,SPKR-BLACK ACL-L/M
4	8Z-CL8-204-010		CUSH,FOOT<101YJSN,101YJ1SN>
5	8B-CLB-030-010		FRAME,SPKR ASSY<101YJSN,131YJSN>
5	8B-CLM-035-010		FRAME,SPKR ASSY<101YJ1SN>
5	8B-CLB-050-010		FRAME,SPKR ASSY E<131YJ2SN>
6	86-CL9-214-010		HLDL,CORD (SPKR)
7	8A-CLL-600-010		SPKR, 4OHM 5W ACL-L

*NOTE 101LH: SX-SLM101 YJSN
101K, EZ: SX-SLM101 YJ1SN
131EZ: SX-SLM131 YJ2SN
131U: SX-SLM131 YJSN

アイワ株式会社 〒110-8710 東京都台東区池之端1-2-11 ☎03(3827)3111 (代表)

AIWA CO.,LTD. 2-11, IKENOHATA 1-CHOME, TAITO-KU, TOKYO 110-8710, JAPAN TEL:03 (3827) 3111