

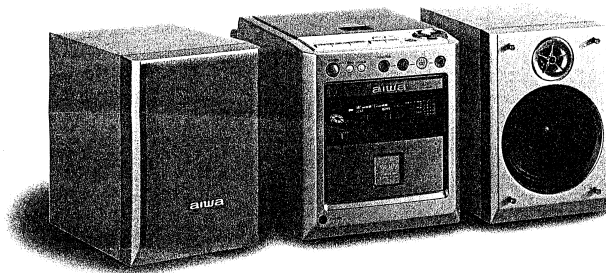

XR-M78 XR-M77

EZ

K



SERVICE MANUAL

COMPACT DISC STEREO
SYSTEM

BASIC CD MECHANISM : KSM-213CDM

This Service Manual is the "Revision Publishing" and replaces "Simple Manual"
(S/M Code No. 09-995-331-7T2).

aiwa
S/M Code No. 09-995-331-7R2

REVISION
DATA

TABLE OF CONTENTS

SPECIFICATIONS	3
ACCESSORIES/PACKAGE LIST	3
PROTECTION OF EYES FROM LASER BEAM DURING SERVICING/ Precaution to replace Optical block	4
ELECTRICAL MAIN PARTS LIST	5-8
TRANSISTOR ILLUSTRATION	9
FL GRID ASSIGNMENT/ANODE CONNECTION	10
BLOCK DIAGRAM-1	11, 12
BLOCK DIAGRAM-2	13, 14
WIRING-1 (MAIN: INSERTED PARTS)	15, 16
WIRING-2 (MAIN: CHIP PARTS)	17, 18
SCHEMATIC DIAGRAM-1 (MAIN)	19, 20
SCHEMATIC DIAGRAM-2 (CD)	21, 22
WIRING-3 (CD: INSERTED PARTS)	23, 24
WIRING-4 (CD: CHIP PARTS)	25, 26
WIRING-5 (FRONT)	27, 28
SCHEMATIC DIAGRAM-3 (FRONT)	29, 30
WIRING-6 (TUNER)	31, 32
SCHEMATIC DIAGRAM-4 (TUNER)	33, 34
WIRING-7 (PT: INSERTED PARTS)	35, 36
WIRING-8 (PT: CHIP PARTS)	37, 38
SCHEMATIC DIAGRAM-5 (PT)	39, 40
WIRING-9 (MECHA)	41
VOLTAGE CHART	42-44
ELECTRICAL ADJUSTMENT	45-47
PRACTICAL SERVICE FIGURE	47
IC DESCRIPTION	48-53
IC BLOCK DIAGRAM	54, 55
MECHANICAL PARTS LIST 1/1	56
MECHANICAL EXPLODED VIEW 1/1	57, 58
CD MECHANISM EXPLODED VIEW 1/1	59
CD MECHANISM PARTS LIST 1/1	59
SPEAKER DISASSEMBLY INSTRUCTIONS	60
SPEAKER PARTS LIST 1/1	61

SPECIFICATIONS

MAIN UNIT XR-M77/XR-M78

FM tuner section

Tuning range	87.5 MHz to 108 MHz
Usable sensitivity (IHF)	13.2 dBf
Antenna terminals	75 ohms (unbalanced)

MW tuner section

Tuning range	531 kHz to 1602 kHz (9 kHz step) 530 kHz to 1710 kHz (10 kHz step)
--------------	---

Usable sensitivity	350 μ V/m
Antenna	Loop antenna

LW tuner section

Tuning range	144 kHz to 290 kHz
--------------	--------------------

Usable sensitivity	1400 μ V/m
Antenna	Loop antenna

Amplifier section

Power output	Rated: 12W + 12W (4 ohms, T.H.D. 1%, 1 kHz/DIN 45500) Reference: 15 + 15 W (4 ohms, T.H.D. 10%, 1 kHz/DIN 45324)
--------------	---

EZ MODEL:
DIN MUSIC POWER
36 W + 36 W

Inputs AUX IN: 800 mV

MD IN: 800 mV

Outputs LINE OUT: 1.7 V

SPEAKERS: accept speakers of 4 ohms or more

PHONES (stereo minijack): accepts headphones of 16 ohms or more

DIGITAL OUT: more than -21dBm

Compact disc player section

Laser Semiconductor laser ($\lambda = 780$ nm)

D-A converter 1 bit dual

Signal-to-noise ratio 90 dB (1 kHz, 0 dB)

Harmonic distortion 0.05 % (1 kHz, 0 dB)

Wow and flutter Unmeasurable

SPEAKER SYSTEM SX-LM77/ SX-LM78

Cabinet type 2 way, bass reflex (magnetic shielded type)

Speakers Woofer:
100 mm cone type

Tweeter:
22 mm dome type

Impedance 4 ohms

Output sound pressure level 86 dB/W/m

Dimensions (W \times H \times D) 116 \times 170 \times 197 mm

Weight 1.4 kg

General

Power requirements 230 V AC, 50Hz

Power consumption 50 W

Standby power consumption 1.4 W (power-economizing mode set to ON)

Dimensions (W \times H \times D) 144 \times 170 \times 280 mm

Weight 3.3 kg

- Design and specifications are subject to change without notice.
- Dolby noise reduction manufactured under license from Dolby Laboratories Licensing Corporation. "DOLBY" and the double-D symbol  are trademarks of Dolby Laboratories Licensing Corporation.
- The word "BBE" and the "BBE symbol" are trademarks of BBE Sound, Inc. Under license from BBE Sound, Inc.

ACCESSORIES/PACKAGE LIST

DESCRIPTIONで判断できない物は "REFERENCE NAME LIST" を参照してください。
If can't understand for Description please kindly refer to "REFERENCE NAME LIST".

REF. NO	PART NO.	KANRI NO.	DESCRIPTION
1	87-A90-030-010		ANT, LOOP AM-NC C
2	87-A90-118-010		ANT, WIRE FM (Z)
3	8Z-CLF-906-010		IB, EZ(9L)A<EZS>
3	8Z-CLF-905-010		IB, K(E)A<KS>
4	8Z-CK4-962-010		RC UNIT, RC-ZAT04 (VS)

PROTECTION OF EYES FROM LASER BEAM DURING SERVICING

This set employs laser. Therefore, be sure to follow carefully the instructions below when servicing.

WARNING!

WHEN SERVICING, DO NOT APPROACH THE LASER EXIT WITH THE EYE TOO CLOSELY. IN CASE IT IS NECESSARY TO CONFIRM LASER BEAM EMISSION. BE SURE TO OBSERVE FROM A DISTANCE OF MORE THAN 30cm FROM THE SURFACE OF THE OBJECTIVE LENS ON THE OPTICAL PICK-UP BLOCK.

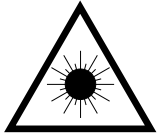

- Caution: Invisible laser radiation when open and interlocks defeated avoid exposure to beam.
- Advarsel: Usynlig laserstråling ved åbning, når sikkerhedsafbrydere er ude af funktion. Undgå udsættelse for stråling.

VAROITUS!

Laiteen Käyttäminen muulla kuin tässä käyttöohjeessa mainituilla tavalla saattaa altistaa käyttäjän turvallisuusluokan 1 ylittävälle näkymättömälle lasersäteilylle.

WARNING!

Om apparaten används på annat sätt än vad som specificeras i denna bruksanvisning, kan användaren utsättas för osynlig laserstråling, som överskrider gränsen för laserklass 1.

Precaution to replace Optical block (KSS-213C)

Body or clothes electrostatic potential could ruin laser diode in the optical block. Be sure ground body and workbench, and use care the clothes do not touch the diode.

- 1) After the connection, remove solder shown in the right figure.

CAUTION

Use of controls or adjustments or performance of procedures other than those specified herein may result in hazardous radiation exposure.

ATTENTION

L'utilisation de commandes, réglages ou procédures autres que ceux spécifiés peut entraîner une dangereuse exposition aux radiations.

ADVARSEL!

Usynlig laserstråling ved åbning, når sikkerhedsafbrydere er ude af funktion. Undgå udsættelse for stråling.

This Compact Disc player is classified as a CLASS 1 LASER product.

The CLASS 1 LASER PRODUCT label is located on the rear exterior.

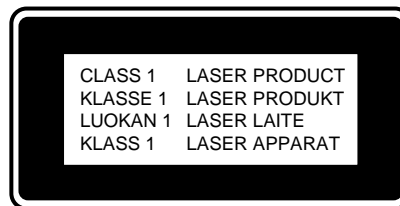

PICK-UP Assy P.C.B

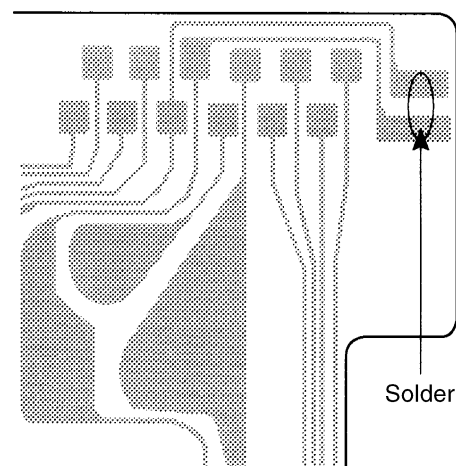

ELECTRICAL MAIN PARTS LIST

DESCRIPTIONで判断できない物は "REFERENCE NAME LIST" を参照してください。
 If can't understand for Description please kindly refer to "REFERENCE NAME LIST".

REF. NO	PART NO.	KANRI NO.	DESCRIPTION	REF. NO	PART NO.	KANRI NO.	DESCRIPTION
IC				C552	87-010-213-080		C-CAP,S 0.015-50 B
	8Z-CL5-601-010	C-IC,LC876564		C553	87-015-688-080		CAP,E 4.7-35 7L
	87-070-282-010	IC,BU2092		C554	87-015-688-080		CAP,E 4.7-35 7L
	8Z-CL5-616-010	IC,RPM638CBRL676/6938-V4		C555	87-015-692-080		CAP,E 0.22-50 7L
	87-A20-446-010	C-IC,LA9241ML		C556	87-015-692-080		CAP,E 0.22-50 7L
	87-A20-459-010	C-IC,LC78622ED		C557	87-015-692-080		CAP,E 0.22-50 7L
	87-A20-445-010	IC,BA5936		C558	87-015-692-080		CAP,E 0.22-50 7L
	87-A21-111-040	C-IC,M62495FP		C561	87-015-680-080		CAP,E 47-10 7L
	87-A21-022-040	C-IC,BA3880FS		C562	87-015-680-080		CAP,E 47-10 7L
	87-017-915-080	IC,BU4094BCF		C563	87-010-154-080		CAP CHIP 10P
	87-070-391-040	IC,BA4558F		C565	87-015-688-080		CAP,E 4.7-35 7L
	87-A20-909-010	IC,LA4663		C566	87-015-688-080		CAP,E 4.7-35 7L
	87-070-127-110	IC,LC72131 D		C567	87-015-679-080		33U 10V SRA
	87-A20-913-010	IC,LA1837NL		C568	87-015-679-080		33U 10V SRA
				C585	87-015-695-080		CAP,E 1-50 7L
TRANSISTOR				C586	87-015-695-080		CAP,E 1-50 7L
	89-327-125-080	CHIP TR,2SC2712GR		C804	87-010-196-080		CHIP CAPACITOR,0.1-25
	87-A30-087-080	C-FET,2SK2158		C805	87-010-196-080		CHIP CAPACITOR,0.1-25
	87-026-230-080	CHIP-TR,DTA114YK		C806	87-010-196-080		CHIP CAPACITOR,0.1-25
	89-111-625-080	TR,2SA1162 (0.15W)		C807	87-010-196-080		CHIP CAPACITOR,0.1-25
	87-026-235-080	CHIP-TR,DTC114EK		C808	87-010-389-090		CAP, E 2200-25 SME
	87-026-463-080	TR,2SA933S (0.3W)		C809	87-012-140-080		CAP 470P
	87-026-239-080	TR,DTC114TK (0.2W)		C811	87-010-060-080		ELECTROLYTIC 100-16V
	87-026-213-080	CHIP-TR,DTC114YK		C812	87-010-060-080		ELECTROLYTIC 100-16V
	89-213-702-010	TR,2SB1370 (1.8W)		C813	87-010-235-080		CAP,E 470-16 SME
	87-026-211-080	TR,DTA144EK		C819	87-010-194-080		CAP, CHIP 0.047
	S7-805-000-020	TR,PE8050		C820	87-010-194-080		CAP, CHIP 0.047
	87-026-210-080	TR,DTC144EK		C821	87-010-889-010		CAP,E 6800-25
	89-318-155-810	TR,2SC1815GR		C822	87-010-387-080		CAP,E 470-25 SME
	S7-855-000-020	TR,PE8550EK		C829	87-015-681-080		CAP,E 10-16 7L
	87-026-235-010	TR,DTC114EK		C830	87-010-197-080		CAP, CHIP 0.01 DM
DIODE				C833	87-010-213-080		C-CAP,S 0.015-50 B
	87-A40-345-080	ZENER,MTZJ10C		C834	87-010-213-080		C-CAP,S 0.015-50 B
	87-070-345-080	DIODE,IN4148		C835	87-015-688-080		CAP,E 4.7-35 7L
	87-A40-337-080	ZENER,MTZJ 6.8B		C836	87-015-688-080		CAP,E 4.7-35 7L
	88-CD9-651-090	DIODE,J05		C837	87-010-247-080		CAP, ELECT 100-50V
	87-A40-466-080	ZENER,MTZJ2.7A		C847	87-015-691-080		CAP,E 0.1-50 7L
	87-002-743-080	ZENER,MTZJ 33B		C848	87-015-691-080		CAP,E 0.1-50 7L
	8Z-CL5-626-010	DIODE,6A1		C849	87-010-182-080		C-CAP,S 2200P-50 B
	S8-CM2-609-010	DIODE,IN4001B		C850	87-010-182-080		C-CAP,S 2200P-50 B
MAIN C.B				C853	87-010-060-080		ELECTROLYTIC 100-16V
C510	87-015-688-080	CAP,E 4.7-35 7L		C854	87-010-060-080		ELECTROLYTIC 100-16V
C511	87-015-688-080	CAP,E 4.7-35 7L		C855	87-010-060-080		ELECTROLYTIC 100-16V
C512	87-015-688-080	CAP,E 4.7-35 7L		C856	87-010-060-080		ELECTROLYTIC 100-16V
C513	87-015-688-080	CAP,E 4.7-35 7L		C859	87-015-694-080		CAP,E 0.47-50 7L
C514	87-015-688-080	CAP,E 4.7-35 7L		CN201	87-A60-778-010		CONN,18P B TMC-D(P)
C515	87-010-188-080	CAP,CHIP 6800P		CN203	8Z-CL5-618-010		CONN,7P H WHT 528070710
C516	87-010-188-080	CAP,CHIP 6800P		CN803	87-009-031-010		CONNECTOR, 3P
C517	87-012-140-080	CAP 470P		△FR802	S1-250-300-000		FUSE,2.5A 60V
C518	87-012-140-080	CAP 470P		△FR803	S1-250-300-000		FUSE,2.5A 60V
C519	87-010-178-080	CHIP CAP 1000P		J801	87-009-216-010		JACK, DIA 3.5
C520	87-010-178-080	CHIP CAP 1000P		J802	87-A60-238-010		TERMINAL,SP 4P (MSC)
C521	87-015-695-080	CAP,E 1-50 7L		L801	87-005-742-080		COIL,100UH J SP02
C522	87-015-695-080	CAP,E 1-50 7L		L802	87-005-742-080		COIL,100UH J SP02
C523	87-010-196-080	CHIP CAPACITOR,0.1-25		W801	8Z-CL5-622-010		F-CABLE,9P 2.5 250MM UL2468 AW
C524	87-015-684-080	CAP,E 47-16 7L		FRONT C.B			
C525	87-010-178-080	CHIP CAP 1000P		C201	87-010-196-080		CHIP CAPACITOR,0.1-25
C526	87-010-197-080	CAP, CHIP 0.01 DM		C202	87-010-196-080		CHIP CAPACITOR,0.1-25
C528	87-010-195-080	C-CAP,S 0.068-25 F		C203	87-010-196-080		CHIP CAPACITOR,0.1-25
C530	87-015-684-080	CAP,E 47-16 7L		C204	87-015-698-080		CAP,E 4.7-50 7L
C531	87-010-196-080	CHIP CAPACITOR,0.1-25		C205	87-015-698-080		CAP,E 4.7-50 7L
C532	87-010-322-080	C-CAP,S 100P-50 CH		C206	87-010-408-080		CAP, ELECT 47-50V
C545	87-015-696-080	CAP,E 2.2-50 7L		C207	87-010-196-080		CHIP CAPACITOR,0.1-25
C546	87-015-696-080	CAP,E 2.2-50 7L		C208	87-010-322-080		C-CAP,S 100P-50 CH
C551	87-010-213-080	C-CAP,S 0.015-50 B		C209	87-010-196-080		CHIP CAPACITOR,0.1-25
				C210	87-010-312-080		C-CAP,S 15P-50 CH
				C211	87-010-198-080		CAP, CHIP 0.022
				C212	87-010-196-080		CHIP CAPACITOR,0.1-25

REF. NO	PART NO.	KANRI NO.	DESCRIPTION	REF. NO	PART NO.	KANRI NO.	DESCRIPTION
C213	87-012-145-080		CAP, CHIP S 270P CH	C445	87-010-196-080		CHIP CAPACITOR,0.1-25
C214	87-010-178-080		CHIP CAP 1000P	C446	87-010-196-080		CHIP CAPACITOR,0.1-25
C215	87-015-681-080		CAP,E 10-16 7L	C447	87-010-196-080		CHIP CAPACITOR,0.1-25
C216	87-015-694-080		CAP,E 0.47-50 7L	C448	87-010-315-080		C-CAP,S 27P-50 CH
C217	87-010-196-080		CHIP CAPACITOR,0.1-25	C450	87-012-140-080		CAP 470P
C218	87-010-370-080		CAP, ELECT 330-6.3V	C451	87-012-156-080		C-CAP,S 220P-50 CH
C221	87-010-196-080		CHIP CAPACITOR,0.1-25	C453	87-010-322-080		C-CAP,S 100P-50 CH
C222	87-015-694-080		CAP,E 0.47-50 7L	C455	87-010-060-080		ELECTROLYTIC 100-16V
C223	87-010-196-080		CHIP CAPACITOR,0.1-25	C457	87-010-316-080		C-CAP,S 33P-50 CH
C224	87-015-681-080		CAP,E 10-16 7L	C458	87-010-316-080		C-CAP,S 33P-50 CH
C225	87-010-194-080		CAP, CHIP 0.047	C459	87-010-060-080		ELECTROLYTIC 100-16V
C227	87-010-248-080		CAP, ELECT 220-10V	C460	87-010-196-080		CHIP CAPACITOR,0.1-25
C228	87-010-196-080		CHIP CAPACITOR,0.1-25	C461	87-010-196-080		CHIP CAPACITOR,0.1-25
C229	87-015-696-080		CAP,E 2.2-50 7L	C462	87-A10-505-080		CAP,E 220-6.3 SF
CN201	87-A60-770-010		CONN,18P B TMC-D(X)	C465	87-015-688-080		CAP,E 4.7-35 7L
CN205	8Z-CL5-617-010		CONN,7P V WHT 528060710	C466	87-010-196-080		CHIP CAPACITOR,0.1-25
D217	87-020-331-080		CHIP-DIODE,DAN202K	C467	87-010-060-080		ELECTROLYTIC 100-16V
D219	87-020-331-080		CHIP-DIODE,DAN202K	C468	87-010-322-080		C-CAP,S 100P-50 CH
D220	87-020-331-080		CHIP-DIODE,DAN202K	C469	87-012-154-080		C-CAP,S 150P-50 CH
D221	87-020-331-080		CHIP-DIODE,DAN202K	C475	87-010-197-080		CAP, CHIP 0.01 DM
D222	87-020-330-080		DIODE,DAP202K	C476	87-010-236-080		CAP,E 1000-10 SME
DP201	8Z-CL1-630-010		FL,13-ST-36GNAK	C477	87-010-197-080		CAP, CHIP 0.01 DM
L201	87-A50-052-010		COIL,CLOCK 5.76MHZ T1	C479	87-010-060-080		ELECTROLYTIC 100-16V
LED201	8Z-CL5-613-010		LED,SE6201AT RED W/REFCT	C480	87-010-197-080		CAP, CHIP 0.01 DM
LED202	8Z-CL5-615-010		LED,W03327GRHW GR/RED DUAL COL	C481	87-015-681-080		CAP,E 10-16 7L
LED203	8Z-CL5-615-010		LED,W03327GRHW GR/RED DUAL COL	C482	87-015-681-080		CAP,E 10-16 7L
LED204	8Z-CL5-615-010		LED,W03327GRHW GR/RED DUAL COL	C483	87-010-181-080		CAP,CHIP S 1800P
LED205	8Z-CL5-615-010		LED,W03327GRHW GR/RED DUAL COL	C484	87-010-181-080		CAP,CHIP S 1800P
S201	87-036-073-010		TACT SWITCH	C490	87-010-196-080		CHIP CAPACITOR,0.1-25
S202	87-036-073-010		TACT SWITCH	C491	87-015-684-080		CAP,E 47-16 7L
S203	87-036-073-010		TACT SWITCH	C492	87-015-682-080		CAP,E 22-16 7L
S204	87-036-073-010		TACT SWITCH	C493	87-010-197-080		CAP, CHIP 0.01 DM
S205	87-036-073-010		TACT SWITCH	C494	87-010-197-080		CAP, CHIP 0.01 DM
S206	87-036-073-010		TACT SWITCH	C494	87-010-197-080		CAP, CHIP 0.01 DM
S207	87-036-073-010		TACT SWITCH	C495	87-010-197-080		CAP, CHIP 0.01 DM
CD C.B				C823	87-010-260-080		CAP, ELECT 47-25V
C401	87-015-697-080		CAP,E 3.3-50 7L	C824	87-010-260-080		CAP, ELECT 47-25V
C402	87-010-197-080		CAP, CHIP 0.01 DM	C825	87-010-260-080		CAP, ELECT 47-25V
C403	87-010-264-010		CAP,E 100-10	C825	87-010-260-080		CAP, ELECT 47-25V
C404	87-010-754-080		CAP,E220-10 SRA 7L	C826	87-010-260-080		CAP, ELECT 47-25V
C405	87-010-197-080		CAP, CHIP 0.01 DM	C827	87-010-247-080		CAP, ELECT 100-50V
C406	87-015-680-080		CAP,E 47-10 7L	C828	87-010-247-080		CAP, ELECT 100-50V
C407	87-010-178-080		CHIP CAP 1000P	C851	87-010-404-080		CAP, ELECT 4.7-50V
C408	87-010-198-080		CAP, CHIP 0.022	C4401	87-010-322-080		C-CAP,S 100P-50 CH
C409	87-010-754-080		CAP,E220-10 SRA 7L	C4402	87-010-322-080		C-CAP,S 100P-50 CH
C410	87-010-060-080		ELECTROLYTIC 100-16V	C4403	87-010-322-080		C-CAP,S 100P-50 CH
C412	87-015-691-080		CAP,E 0.1-50 7L	C4404	87-010-322-080		C-CAP,S 100P-50 CH
C413	87-010-193-080		CHIP CAPACITOR,0.033	C4405	87-010-322-080		C-CAP,S 100P-50 CH
C414	87-015-681-080		CAP,E 10-16 7L	C4410	87-010-196-080		CHIP CAPACITOR,0.1-25
C416	87-015-692-080		CAP,E 0.22-50 7L	C4411	87-015-681-080		CAP,E 10-16 7L
C417	87-012-157-080		C-CAP,S 330P-50 CH	C4412	87-010-197-080		CAP, CHIP 0.01 DM
C418	87-010-213-080		C-CAP,S 0.015-50 B	CN405	87-009-036-010		CONNECTOR, 8P PH V WHT
C420	87-010-193-080		CHIP CAPACITOR,0.033	CN804	87-009-034-010		CONN,6P PH V
C422	87-010-183-080		C-CAP,S 2700P-50 B	CNA404	8Z-CL5-619-010		CONN ASSY,6P PHR06-170MM JST
C423	87-010-195-080		C-CAP,S 0.068-25 F	CNA407	8Z-CL5-611-010		CONN ASSY,2P RED ZHRAWG28 UL15
C425	87-010-176-080		C-CAP,S 680P-50 SL	CNA408	8Z-CL5-612-010		CONN ASSY,2P BLU ZHRAWG28 UL15
C429	87-010-186-080		CAP,CHIP 4700P	L401	87-005-730-080		COIL,10UH J SP02
C430	87-012-156-080		C-CAP,S 220P-50 CH	L403	S0-035-341-000		BEAD,COIL,100UH
C431	87-015-694-080		CAP,E 0.47-50 7L	L405	87-005-742-080		COIL,100UH J SP02
C431	87-015-692-080		CAP,E 0.22-50 7L<EZ>	L406	S1-212-720-000		BLM21B272SPT
C432	87-015-680-080		CAP,E 47-10 7L	M401	87-A91-069-010		MOT,RF-370CA15370
C433	87-015-695-080		CAP,E 1-50 7L	S401	8Z-CL5-609-010		SW,PUSH 1-1-1 MQS2
C434	87-010-184-080		CHIP CAPACITOR 3300P(K)	S402	8Z-CL5-609-010		SW,PUSH 1-1-1 MQS2
C435	87-010-197-080		CAP, CHIP 0.01 DM	SFR401	87-024-437-080		SFR100K,RH063EC
C436	87-015-680-080		CAP,E 47-10 7L	W401	8Z-CL5-604-010		FF-CABLE, 16P 1.0 100MM
C437	87-015-688-080		CAP,E 4.7-35 7L	WH402	8Z-CL5-610-010		CONN,16P H WHT 528071610
C438	87-010-196-080		CHIP CAPACITOR,0.1-25	WH404	87-A60-116-010		CONN,6P H S2M-6WR
C442	87-010-312-080		C-CAP,S 15P-50 CH	WH407	87-009-865-010		CONN,2P ZH BLU
				WH408	87-009-863-010		CONN,2P ZH WHT
				X401	81-592-641-010		VIB,CER 16.93MHZ

REF. NO	PART NO.	KANRI NO.	DESCRIPTION	REF. NO	PART NO.	KANRI NO.	DESCRIPTION
CONTROL C.B				C725	87-018-131-080		CAP, CER 1000P-50V
C219	87-010-197-080		CAP, CHIP 0.01 DM	C727	87-010-196-080		CHIP CAPACITOR,0.1-25
C220	87-010-197-080		CAP, CHIP 0.01 DM	C728	87-010-248-080		CAP, ELECT 220-10V
LED206	8Z-CL5-614-010		LED,W03304GSC-SC GR	C729	87-012-274-080		CHIP CAP,U 1000P-50B
LED207	8Z-CL5-614-010		LED,W03304GSC-SC GR	C731	87-012-286-080		CAP, U 0.01-25
LED208	8Z-CL5-614-010		LED,W03304GSC-SC GR	C733	87-012-280-080		CAP, U 3300P-50
S210	87-036-073-010		TACT SWITCH	C734	87-012-280-080		CAP, U 3300P-50
S211	87-036-073-010		TACT SWITCH	C752	87-012-282-080		CAP, U 4700P-50
S212	87-036-073-010		TACT SWITCH	C753	87-012-195-080		C-CAP,U 100P-50CH
S217	87-036-073-010		TACT SWITCH	C755	87-012-286-080		CAP, U 0.01-25
S219	87-036-073-010		TACT SWITCH	C756	87-012-286-080		CAP, U 0.01-25
S220	87-036-073-010		TACT SWITCH	C757	87-012-188-080		C-CAP,U 47P-50 CH
S221	87-036-073-010		TACT SWITCH	C758	87-012-167-080		C-CAP,U 5P-50 CH
S223	87-A90-646-010		SW,RTRY 3-2-1 RE0131	C761	87-010-196-080		CHIP CAPACITOR,0.1-25
W203	8Z-CL5-603-010		FF-CABLE, 7P 1.0 150MM UL2896	C762	87-012-286-080		CAP, U 0.01-25
DIGITAL OUT C.B				C763	87-010-829-080		CAP, U 0.047-16
C906	87-010-197-080		CAP, CHIP 0.01 DM	C765	87-012-286-080		CAP, U 0.01-25
C907	87-010-060-080		ELECTROLYTIC 100-16V	C766	87-010-197-080		CAP, CHIP 0.01 DM
LED902	87-A40-558-010		LED,SLZ-8128A-01-A	C768	87-012-286-080		CAP, U 0.01-25
PT C.B				C769	87-010-260-080		CAP, ELECT 47-25V
C571	87-010-060-080		ELECTROLYTIC 100-16V	C770	87-010-829-080		CAP, U 0.047-16
C572	87-010-060-080		ELECTROLYTIC 100-16V	C771	87-010-383-080		CAP, ELECT 33-25V
C573	87-015-688-080		CAP,E 4.7-35 7L	C772	87-010-829-080		CAP, U 0.047-16
C574	87-015-688-080		CAP,E 4.7-35 7L	C773	87-010-196-080		CHIP CAPACITOR,0.1-25
C575	87-015-688-080		CAP,E 4.7-35 7L	C774	87-010-263-080		CAP, ELECT 100-10V
C576	87-015-688-080		CAP,E 4.7-35 7L	C775	87-010-404-080		CAP, ELECT 4.7-50V
C577	87-010-176-080		C-CAP,S 680P-50 SL	C776	87-012-286-080		CAP, U 0.01-25
C578	87-010-176-080		C-CAP,S 680P-50 SL	C777	87-010-493-080		CAP,E 0.47-50 GAS
C579	87-010-318-080		C-CAP,S 47P-50 CH	C778	87-010-401-080		CAP, ELECT 1-50V
C580	87-010-318-080		C-CAP,S 47P-50 CH	C779	87-010-401-080		CAP, ELECT 1-50V
C581	87-012-154-080		C-CAP,S 150P-50 CH	C780	87-010-196-080		CHIP CAPACITOR,0.1-25
C582	87-012-154-080		C-CAP,S 150P-50 CH	C781	87-010-405-080		CAP, ELECT 10-50V
C583	87-015-695-080		CAP,E 1-50 7L	C782	87-010-405-080		CAP, ELECT 10-50V
C584	87-015-695-080		CAP,E 1-50 7L	C783	87-012-286-080		CAP, U 0.01-25
C587	87-015-695-080		CAP,E 1-50 7L	C784	87-012-286-080		CAP, U 0.01-25
C588	87-015-695-080		CAP,E 1-50 7L	C785	87-010-405-080		CAP, ELECT 10-50V
C881	87-A10-479-080		CAP,CER 2200P-250 M E KH	C786	87-010-405-080		CAP, ELECT 10-50V
C883	87-015-697-080		CAP,E 3.3-50 7L	C787	87-012-275-080		C-CAP,U 1200P-50 B
C884	87-010-387-080		CAP,E 470-25 SME	C788	87-012-275-080		C-CAP,U 1200P-50 B
▲FR881	S0-063-200-000		FUSE,63MA,250V	C789	87-012-275-080		C-CAP,U 1200P-50 B
J501	8Z-CL5-608-010		JACK,PIN 6P VERTICAL	C790	87-012-275-080		C-CAP,U 1200P-50 B
▲P1	87-A60-317-010		TERMINAL, 1P MSC	C791	87-010-405-080		CAP, ELECT 10-50V
▲P2	87-A60-317-010		TERMINAL, 1P MSC	C793	87-012-273-080		C-CAP,U 820P-50 B
▲PT881	8Z-CL5-681-010		PT,U L6636EI-66/36	C794	87-010-406-080		CAP, ELECT 22-50V
▲PT882	8Z-NF8-662-010		PT,SUB ZNF-8(E)	C795	87-010-596-080		CAP, S 0.047-16
▲RL881	87-A90-976-010		RELAY,AC12V SDT-S-112LMR	C796	87-010-403-080		CAP, ELECT 3.3-50V
TUNER C.B				C797	87-012-276-080		CAP, CHIP SS 1500 PBK
C701	87-010-381-080		CAP, ELECT 330-16V	C798	87-012-276-080		CAP, CHIP SS 1500 PBK
C702	87-010-404-080		CAP, ELECT 4.7-50V	C799	87-010-829-080		CAP, U 0.047-16
C703	87-012-286-080		CAP, U 0.01-25	C812	87-012-286-080		CAP, U 0.01-25
C704	87-012-286-080		CAP, U 0.01-25	C814	87-012-286-080		CAP, U 0.01-25
C709	87-012-195-080		C-CAP,U 100P-50CH	C820	87-010-260-080		CAP, ELECT 47-25V
C711	87-010-260-080		CAP, ELECT 47-25V	C821	87-012-286-080		CAP, U 0.01-25
C712	87-010-831-080		C-CAP,U,0.1-16F	C822	87-012-286-080		CAP, U 0.01-25
C713	87-012-286-080		CAP, U 0.01-25	C823	87-012-286-080		CAP, U 0.01-25
C714	87-012-286-080		CAP, U 0.01-25	C828	87-010-196-080		CHIP CAPACITOR,0.1-25
C715	87-012-195-080		C-CAP,U 100P-50CH	C829	87-010-196-080		CHIP CAPACITOR,0.1-25
C717	87-012-286-080		CAP, U 0.01-25	C859	87-012-286-080		CAP, U 0.01-25<EZ>
C719	87-012-286-080		CAP, U 0.01-25	C861	87-012-199-080		CAP 220P<EZ>
C720	87-012-195-080		C-CAP,U 100P-50CH	C862	87-012-199-080		CAP 220P<EZ>
C721	87-012-176-080		CAP 15P	C863	87-012-270-080		CAP, U 470P-50<EZ>
C722	87-012-176-080		CAP 15P	C864	87-010-405-080		CAP, ELECT 10-50V<EZ>
C723	87-012-274-080		CHIP CAP,U 1000P-50B	C865	87-010-196-080		CHIP CAPACITOR,0.1-25<EZ>
				C866	87-010-405-080		CAP, ELECT 10-50V<EZ>
				C867	87-012-286-080		CAP, U 0.01-25<EZ>
				C868	87-012-184-080		C-CAP,U 33P-50 CH<EZ>
				C869	87-012-180-080		C-CAP,U 22P-50 CH<EZ>
				C940	87-012-286-080		CAP, U 0.01-25
				C942	87-012-168-080		C-CAP,U 6P-50 CH
				C947	87-012-286-080		CAP, U 0.01-25

REF. NO	PART NO.	KANRI NO.	DESCRIPTION
C949	87-A10-039-080		C-CAP,U 470P-50 J CH
C952	87-012-286-080		CAP, U 0.01-25
C958	87-010-197-080		CAP, CHIP 0.01 DM
C959	87-010-831-080		C-CAP,U,0.1-16F
C960	87-010-196-080		CHIP CAPACITOR,0.1-25
C962	87-010-401-080		CAP, ELECT 1-50V
CF801	87-008-423-010		CERAMIC FILTER, SFE10.7
CF802	82-785-747-010		CF MS2 GHY R
CN701	87-A60-700-010		CONN,13P H GRY TUC-P13X-C1<K>
CN701	87-A60-650-010		CONN,16P H GRY TUC-P16X-C1<EZ>
FFE801	A8-6ZA-191-130		6ZA-1 FEENM
J801	87-033-241-010		TERMINAL,ANT AJ-2039
L771	87-A50-266-010		COIL,FM DET-2N(TOK)
L772	87-A91-110-010		FLTR,PCFJZH-450 (TOK)
L781	87-005-847-080		COIL,2.2UH(CECS)
L791	87-A50-027-010		COIL,1 POLE MPX(TOK)
L792	87-A50-027-010		COIL,1 POLE MPX(TOK)
L832	87-005-847-080		COIL,2.2UH(CECS)
L851	87-005-847-080		COIL,2.2UH(CECS)<EZ>
L941	87-A50-020-010		COIL,ANT LW(COI)
L942	87-A50-019-010		COIL,OSC LW(COI)
L981	8Z-ZA1-665-010		COIL,AM PACK 2(TOK)
TC942	87-011-164-010		CAPACITOR,TRIMMER 30P
X721	87-A70-061-010		VIB,XTAL 4.500MHZ CSA-309
X851	87-A70-091-010		VIB,XTAL 4.332MHZ CSA-309<EZ>

- Regarding connectors, they are not stocked as they are not the initial order items.
The connectors are available after they are supplied from connector manufacturers upon the order is received.

○チップ抵抗部品コード／CHIP RESISTOR PART CODE

チップ抵抗部品コードの成り立ち

Chip Resistor Part Coding

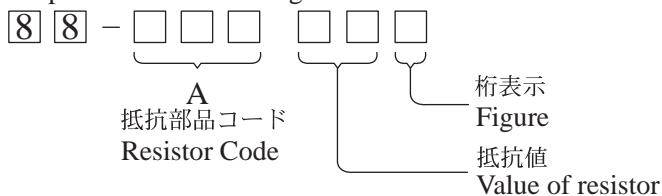

チップ抵抗
Chip resistor

容量 Wattage	種類 Type	許容誤差 Tolerance	記号 Symbol	寸法/Dimensions (mm)			抵抗コード : A Resistor Code : A	
				外形/Form	L	W		t
1/16W	1005	± 5%	CJ		1.0	0.5	0.35	104
1/16W	1608	± 5%	CJ		1.6	0.8	0.45	108
1/10W	2125	± 5%	CJ		2	1.25	0.45	118
1/8W	3216	± 5%	CJ		3.2	1.6	0.55	128

TRANSISTOR ILLUSTRATION

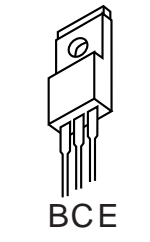
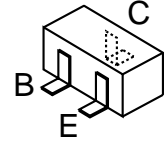

FL (13-ST-36GNAK) GRID ASSIGNMENT/ANODE CONNECTION

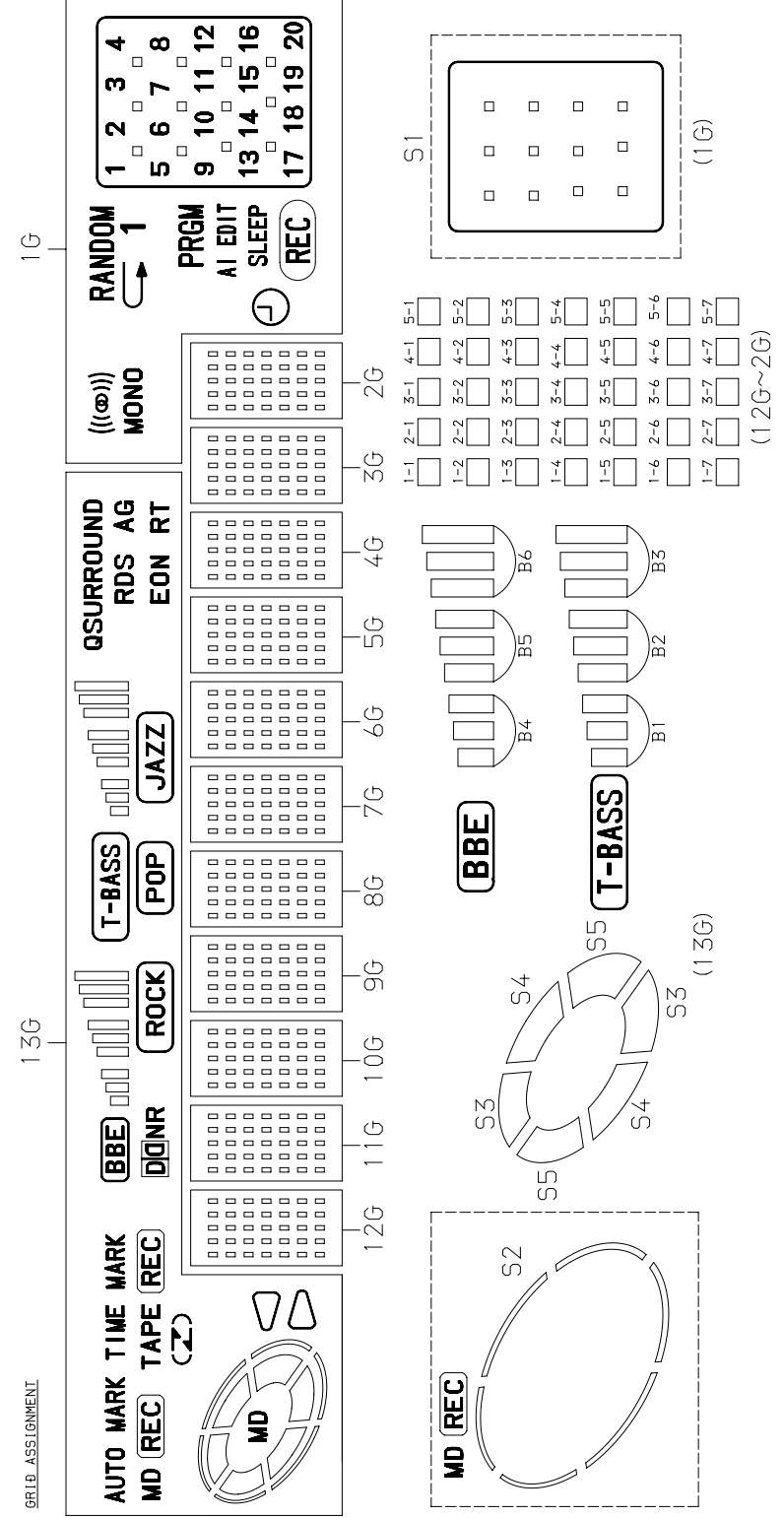

ANODE CONNECTION

P1	13G	120-26	1G	1	1-1	JAZZ
P2				↩	2-1	POP
P3				MONO	3-1	ROCK
P4				RANDOM	4-1	MD NR
P5				((∞))	5-1	RT
P6				PRGM	1-2	EON
P7				AI	2-2	AG
P8				EDIT	3-2	RDS
P9				SLEEP	4-2	B1
P10				⊕	5-2	B2
P11				REC	1-3	B3
P12				CALENDAR	2-3	BASS
P13				1	3-3	B4
P14				2	4-3	B5
P15				3	5-3	B6
P16				4	1-4	BBE
P17				5	2-4	T-BASS
P18				6	3-4	

	13G	120-26	1G	8	4-4	4-4
				9	5-4	5-4
				10	1-5	1-5
				11	2-5	2-5
				12	3-5	3-5
				13	4-5	4-5
				14	5-5	5-5
				15	1-6	1-6
				16	2-6	2-6
				17	3-6	3-6
				18	4-6	4-6
				19	5-6	5-6
				20	1-7	1-7
				S1	2-7	2-7
				-	3-7	3-7
				-	4-7	4-7
				-	5-7	5-7

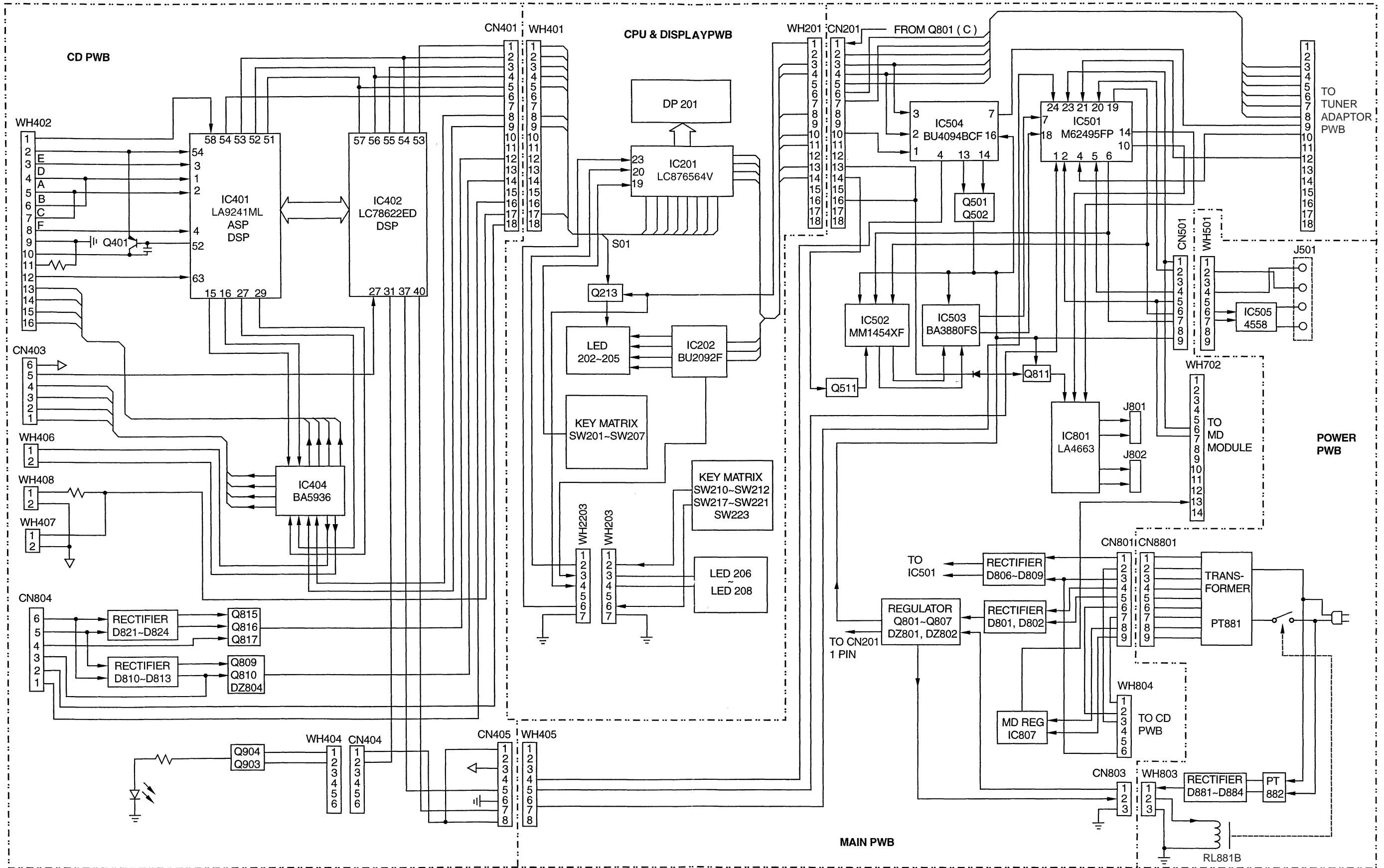

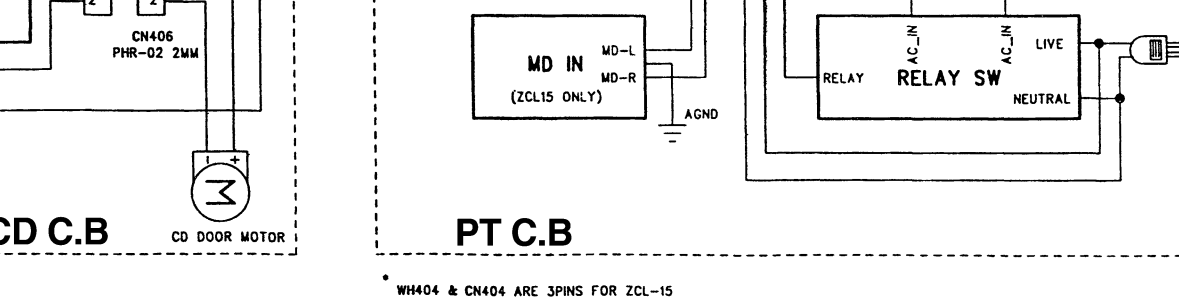
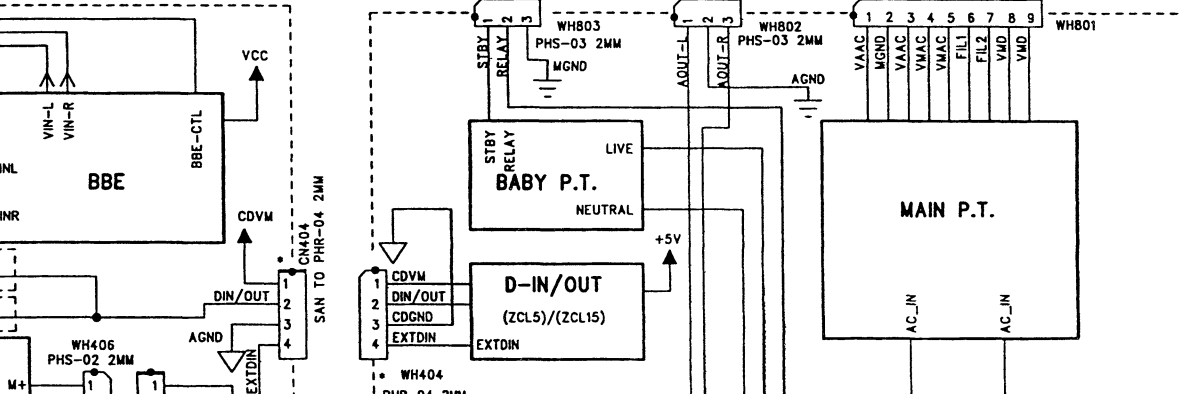
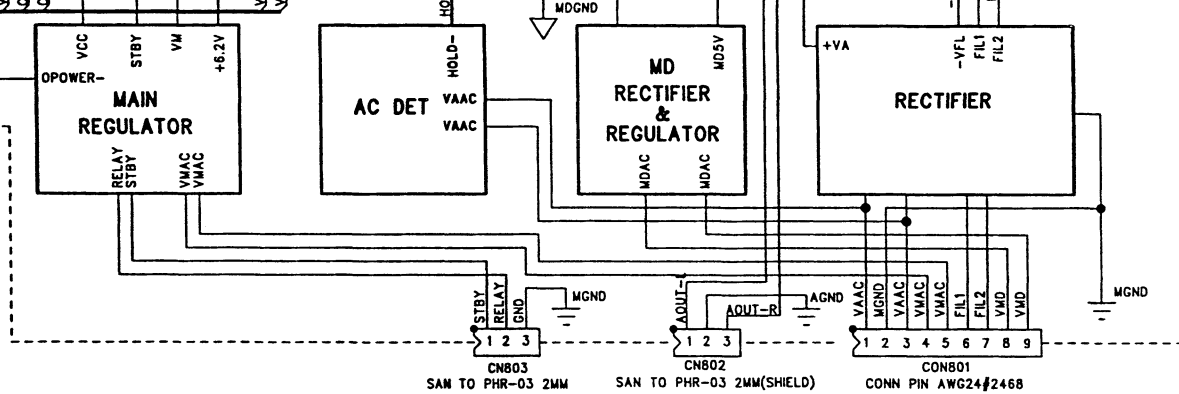
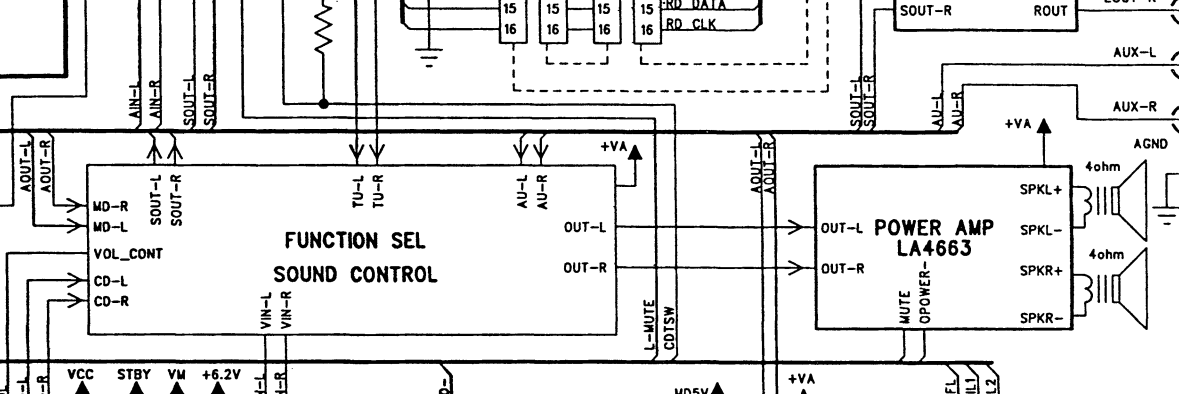
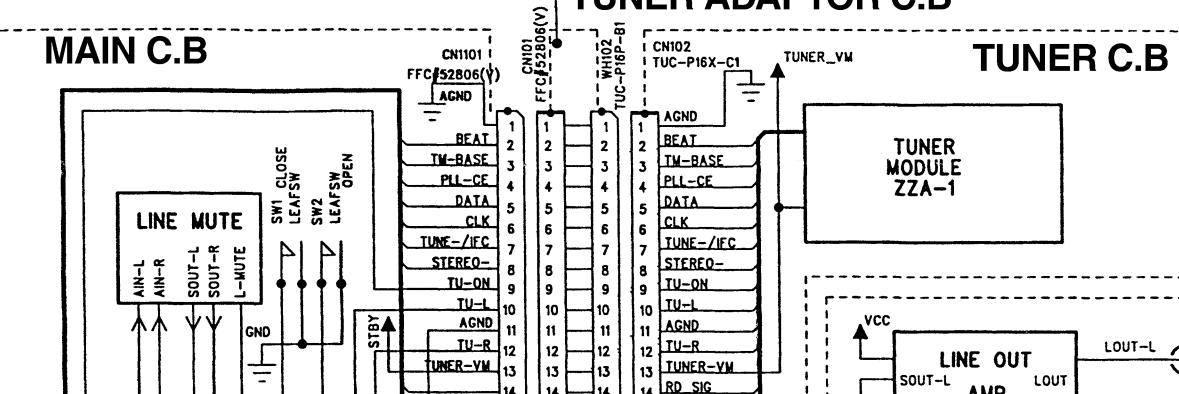
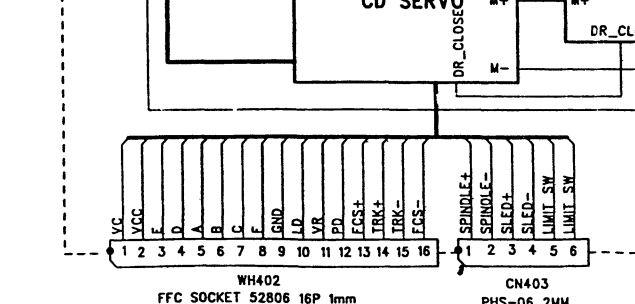
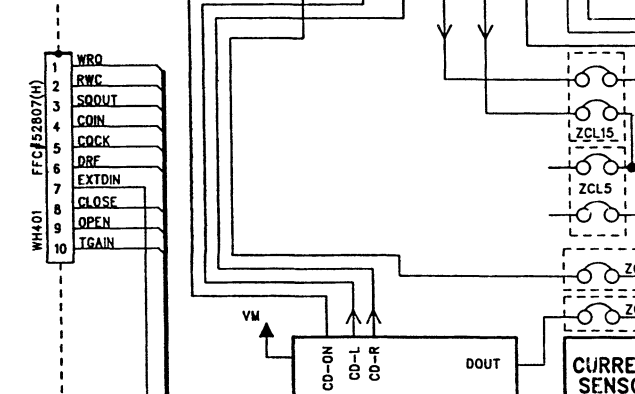
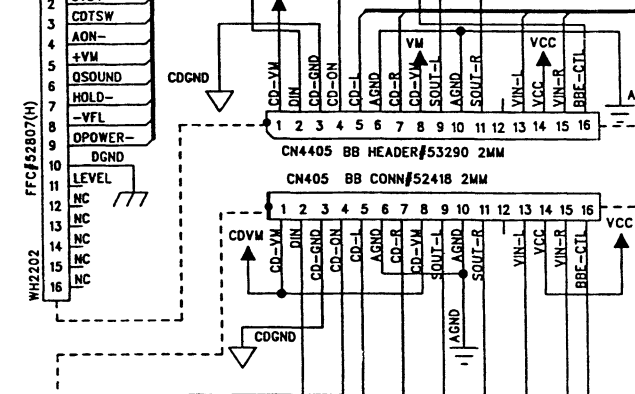
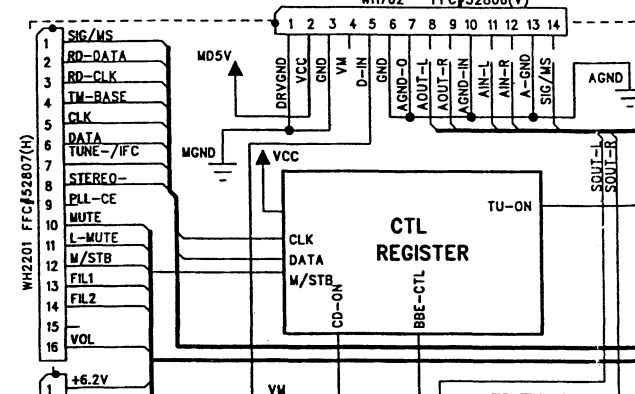
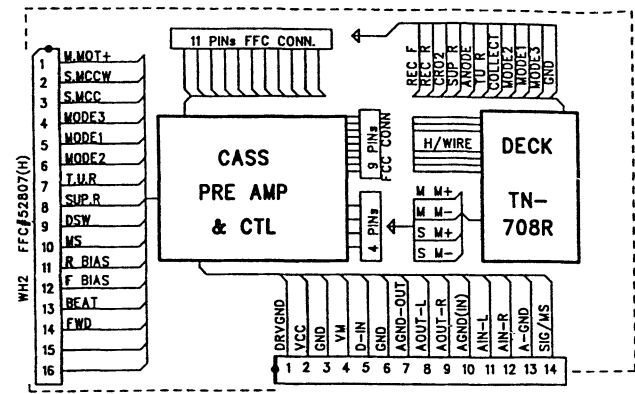
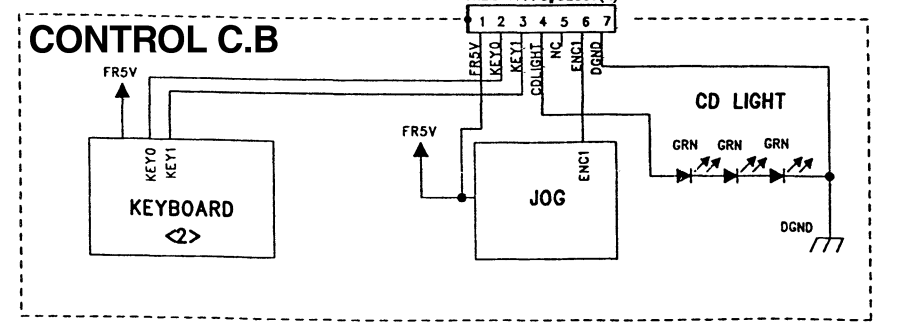
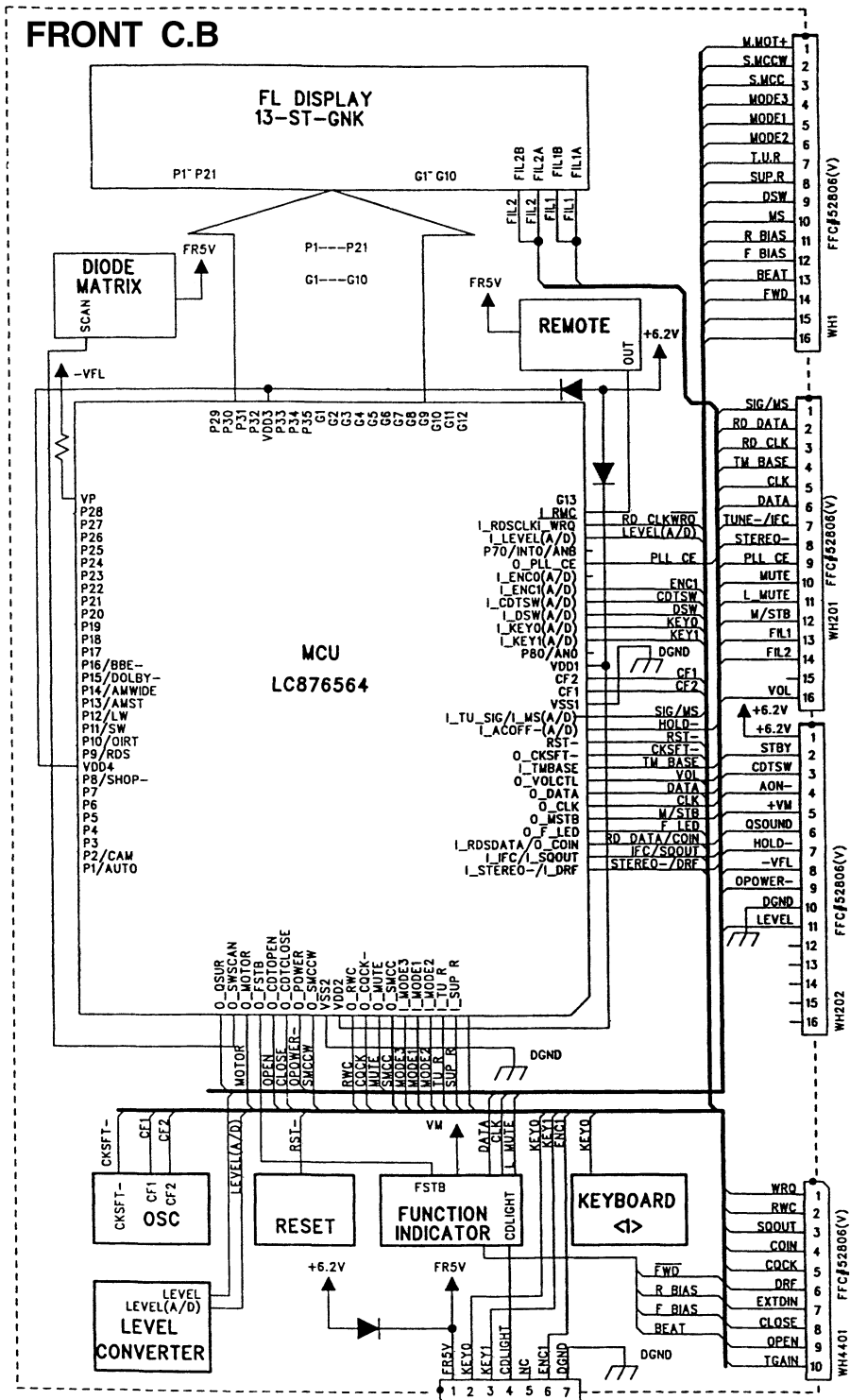

WH402 FFC SOCKET 52806 16P 1mm TO SONY KSM213CDM

CN403 PHS-06 2MM

* WH404 & CN404 ARE 3PINS FOR ZCL-15

TUNER ADAPTOR C. B

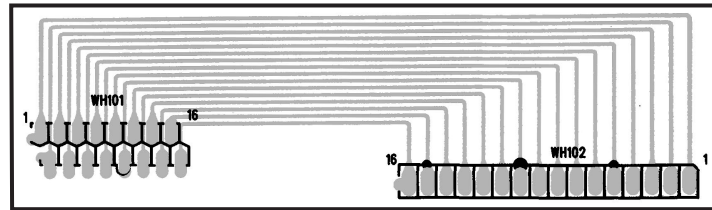

MAIN C. B

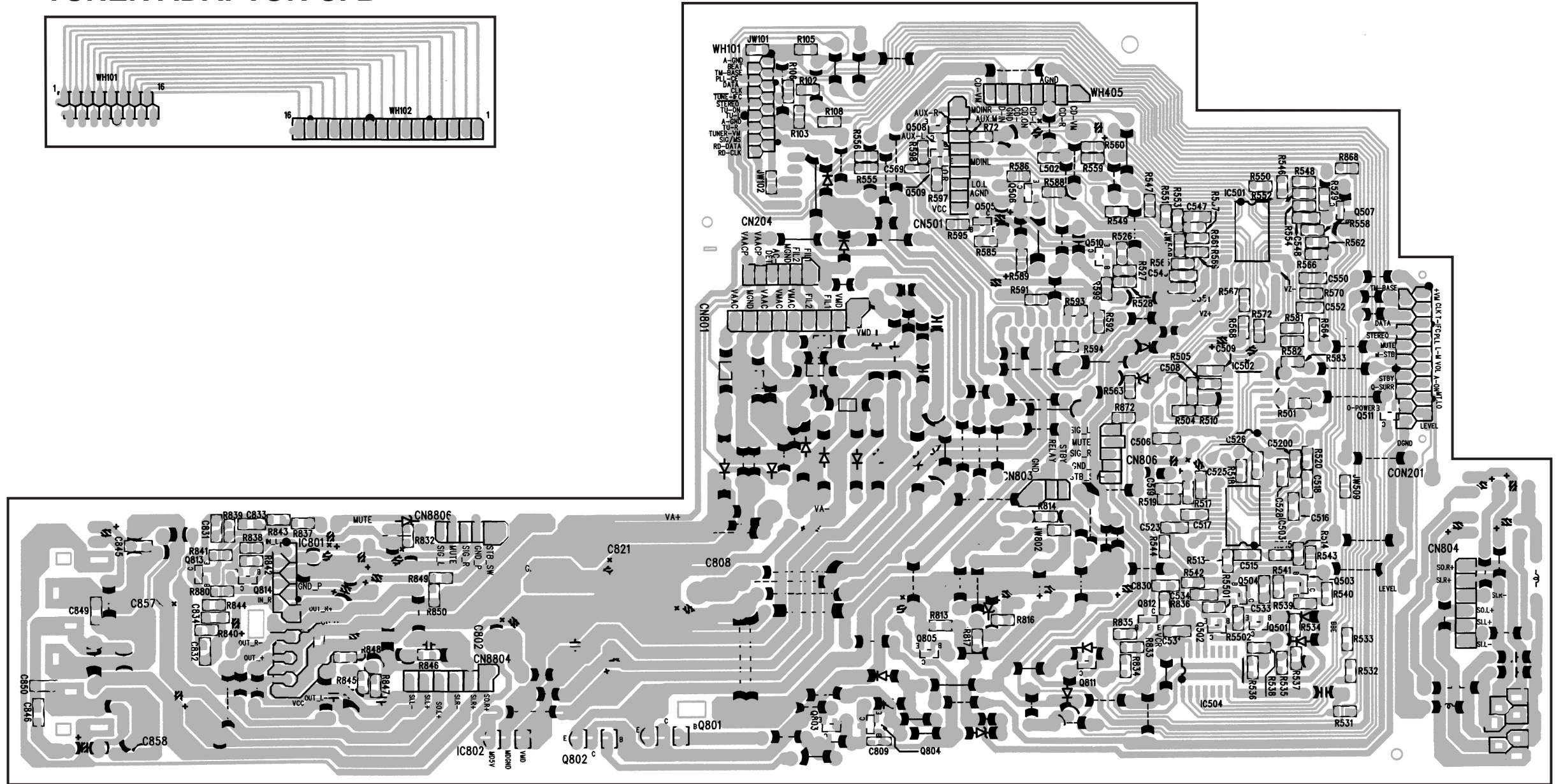

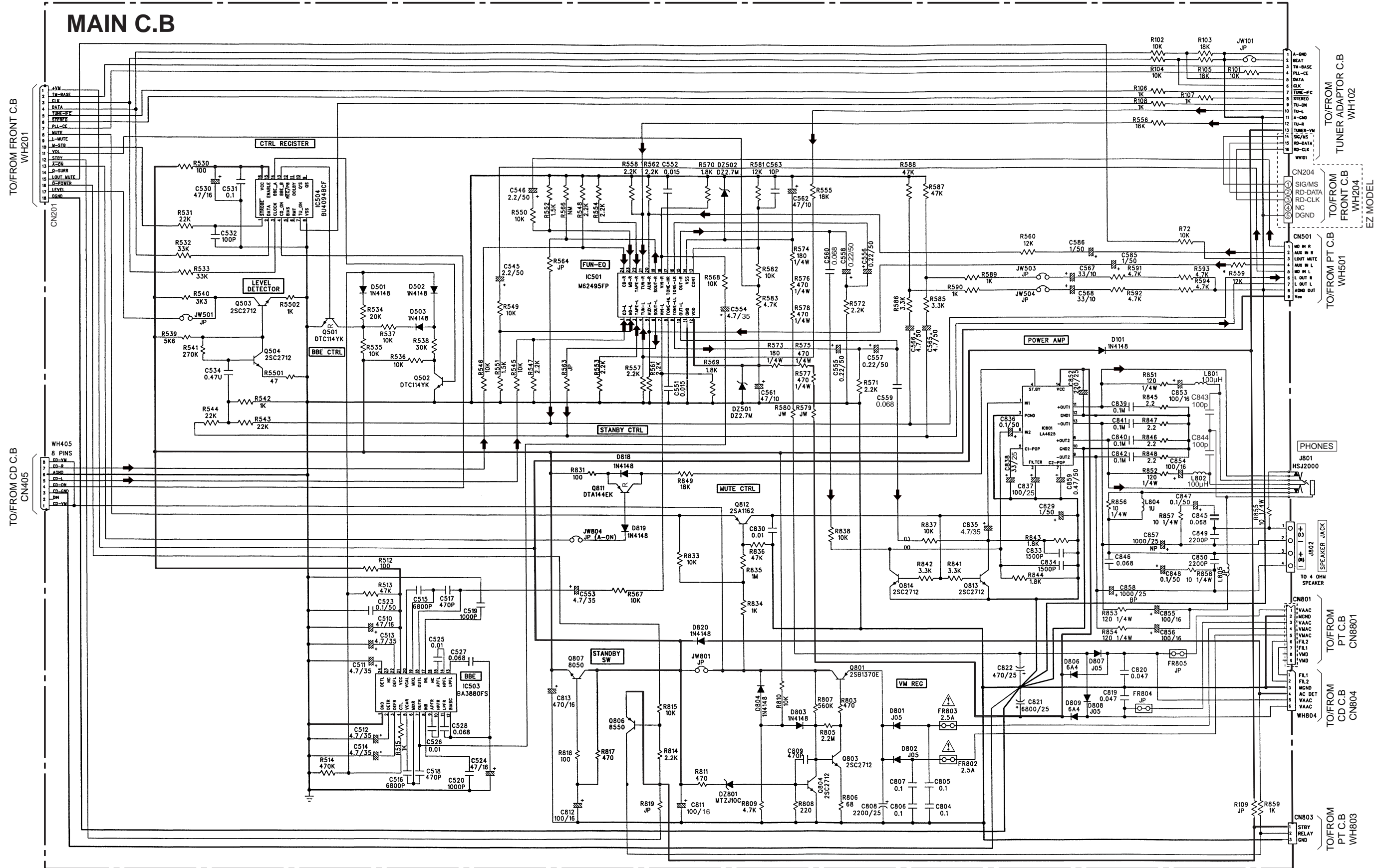

1 2 3 4 5 6 7 8 9 10 11 12 13 14

A
B
C
D
E
F
G
H
I
J
K

CD C. B

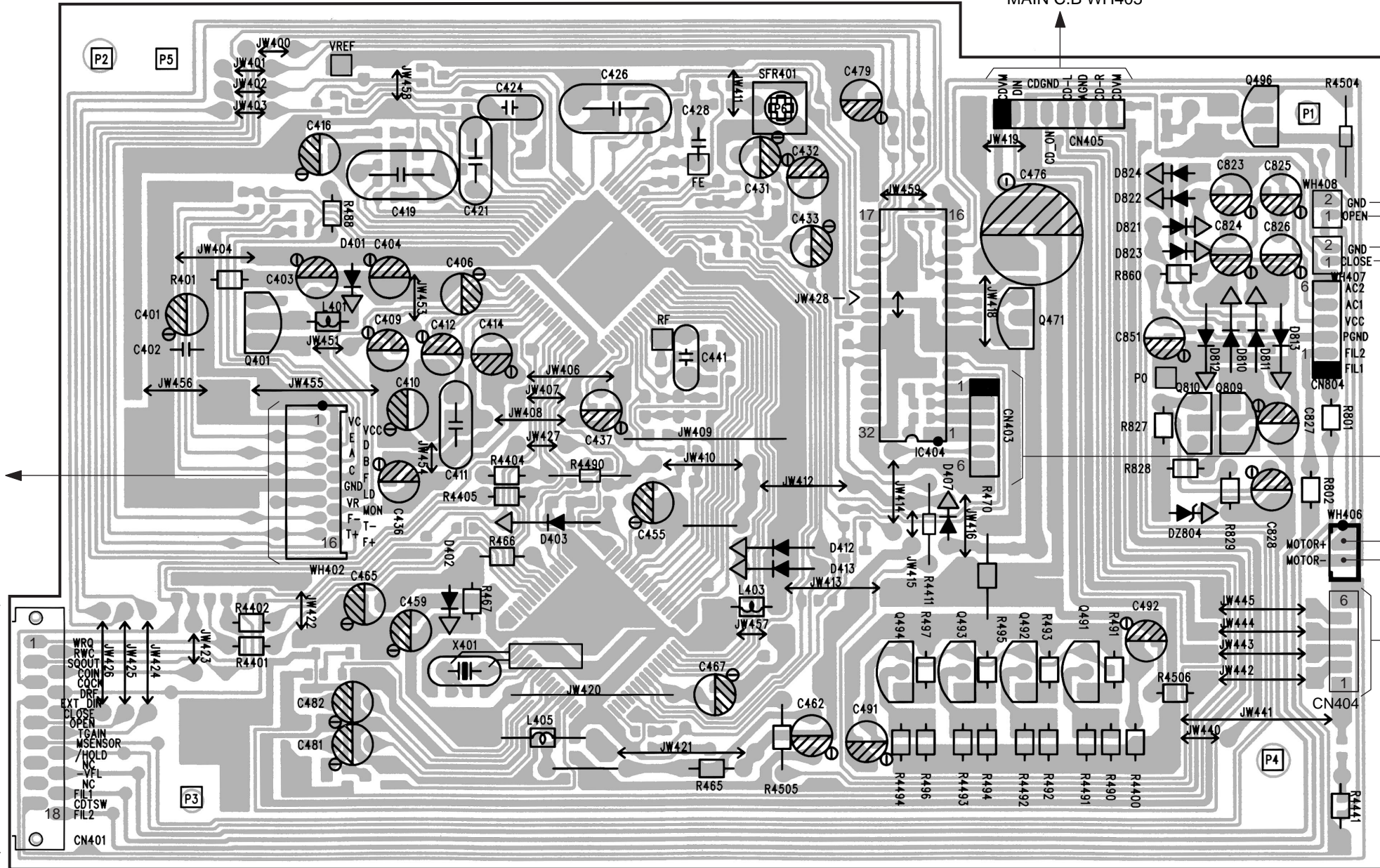

TO/FROM PICK UP ASSY

TO/FROM FRONT C.B WH401

TO/FROM MAIN C.B WH405

S1 (OPEN)
S2 (CLOSE)

TO/FROM MAIN C.B WH804

TO/FROM MOTOR C.B

M1 (LOADING)

TO/FROM DIGITAL OUT C.B WH404

CONTROL C. B

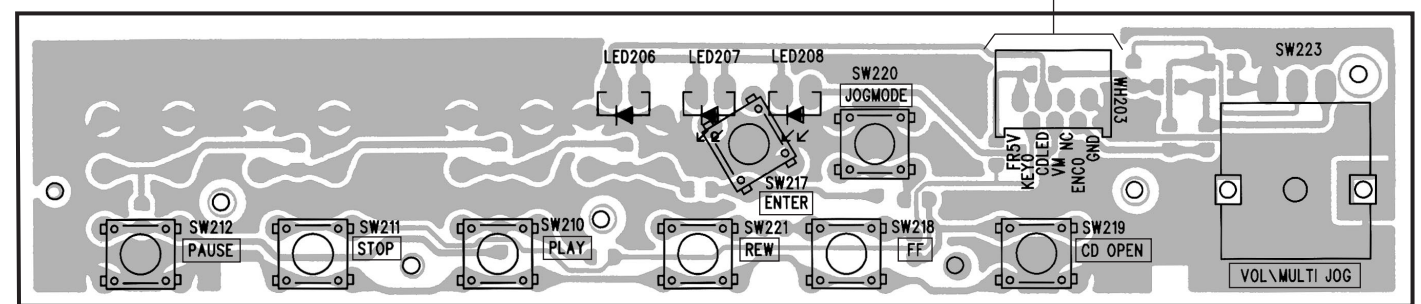

TO/FROM FRONT C.B CN205

A
B
C
D
E
F
G
H
I
J
K

CD C. B

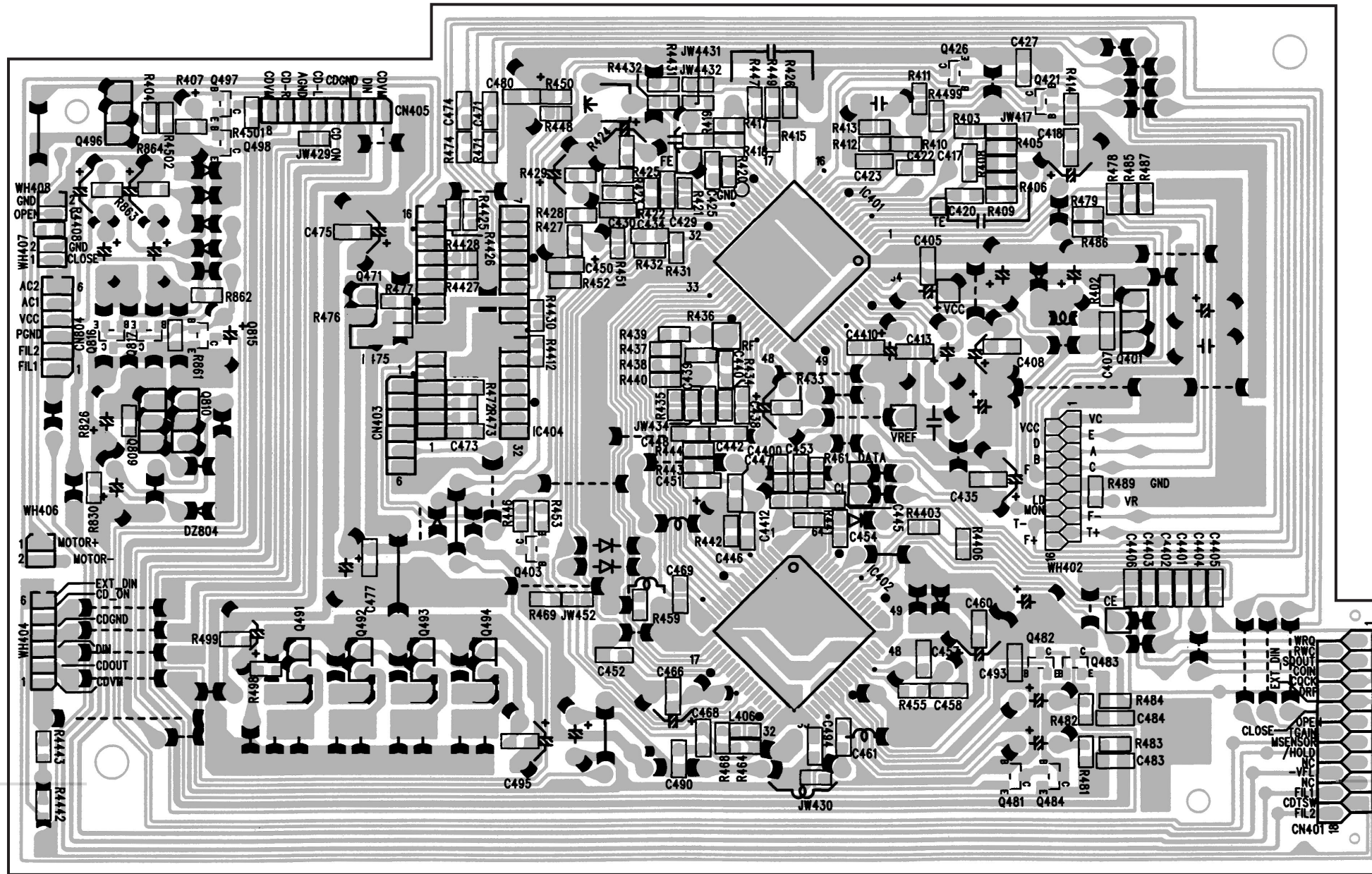

CONTROL C. B

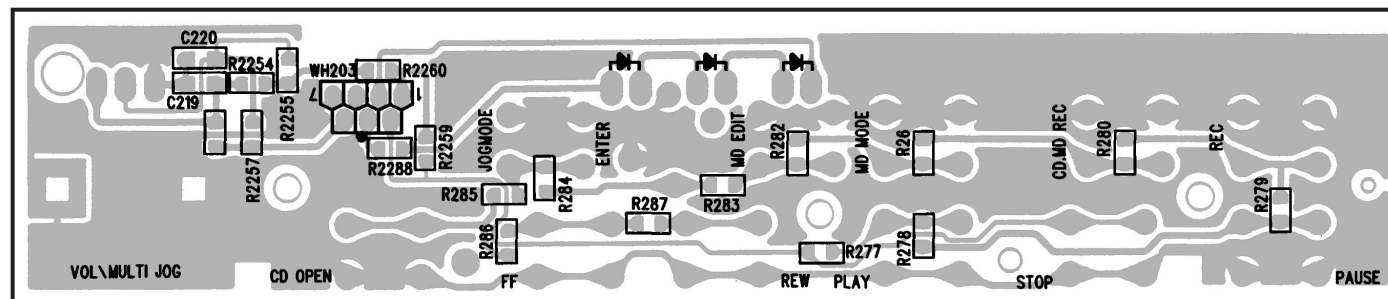

TUNER C.B

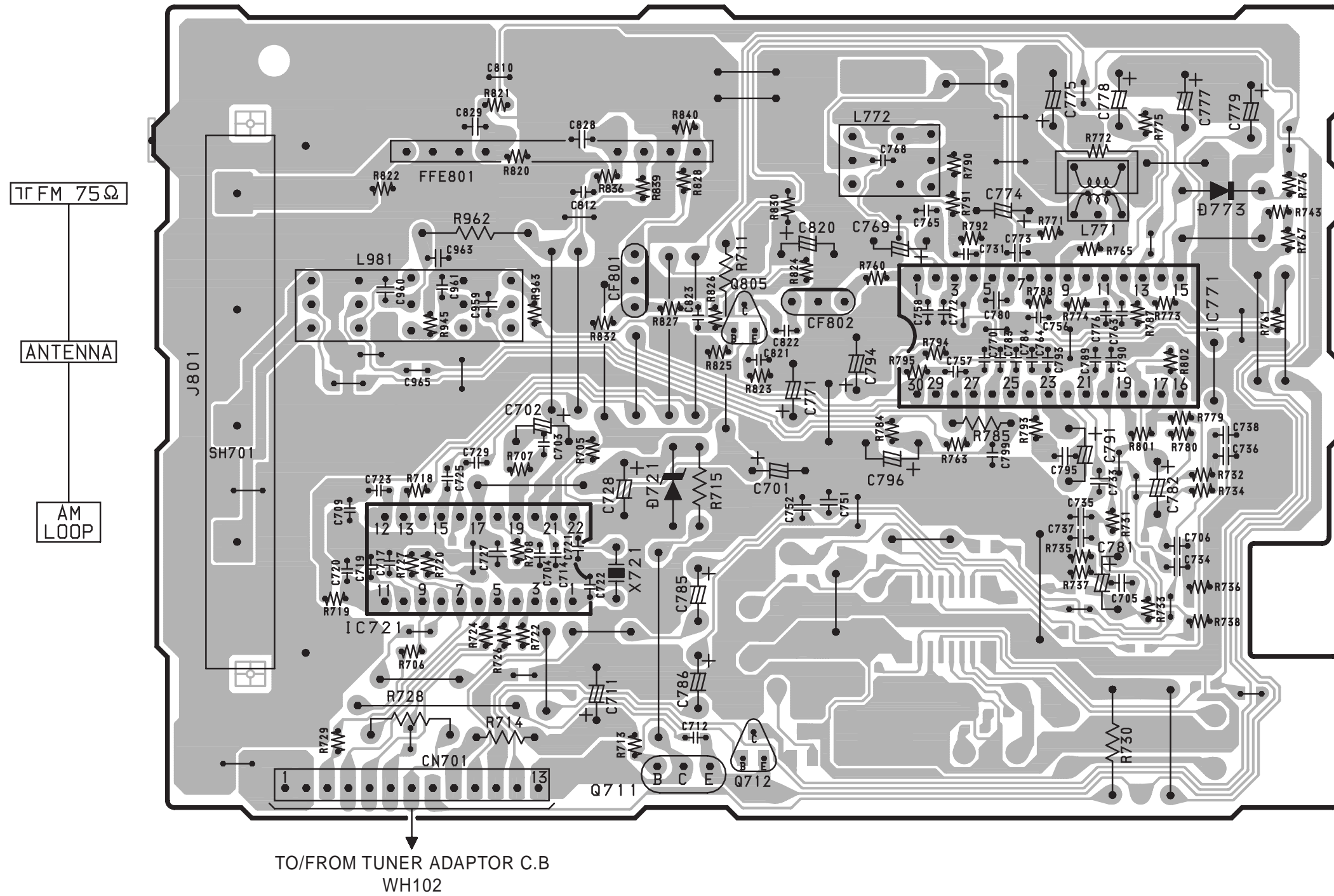

SCHEMATIC DIAGRAM-4 (TUNER)

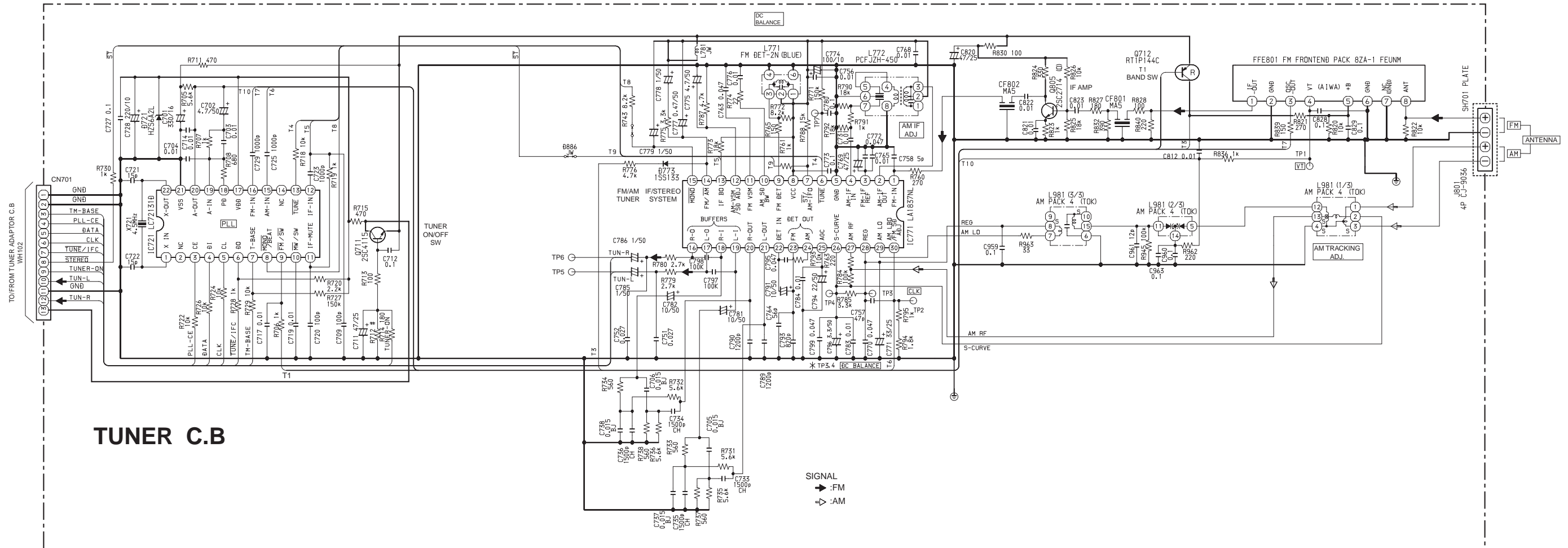

1 2 3 4 5 6 7 8 9 10 11 12 13 14

A
B
C
D
E
F
G
H
I
J
K

PT C. B

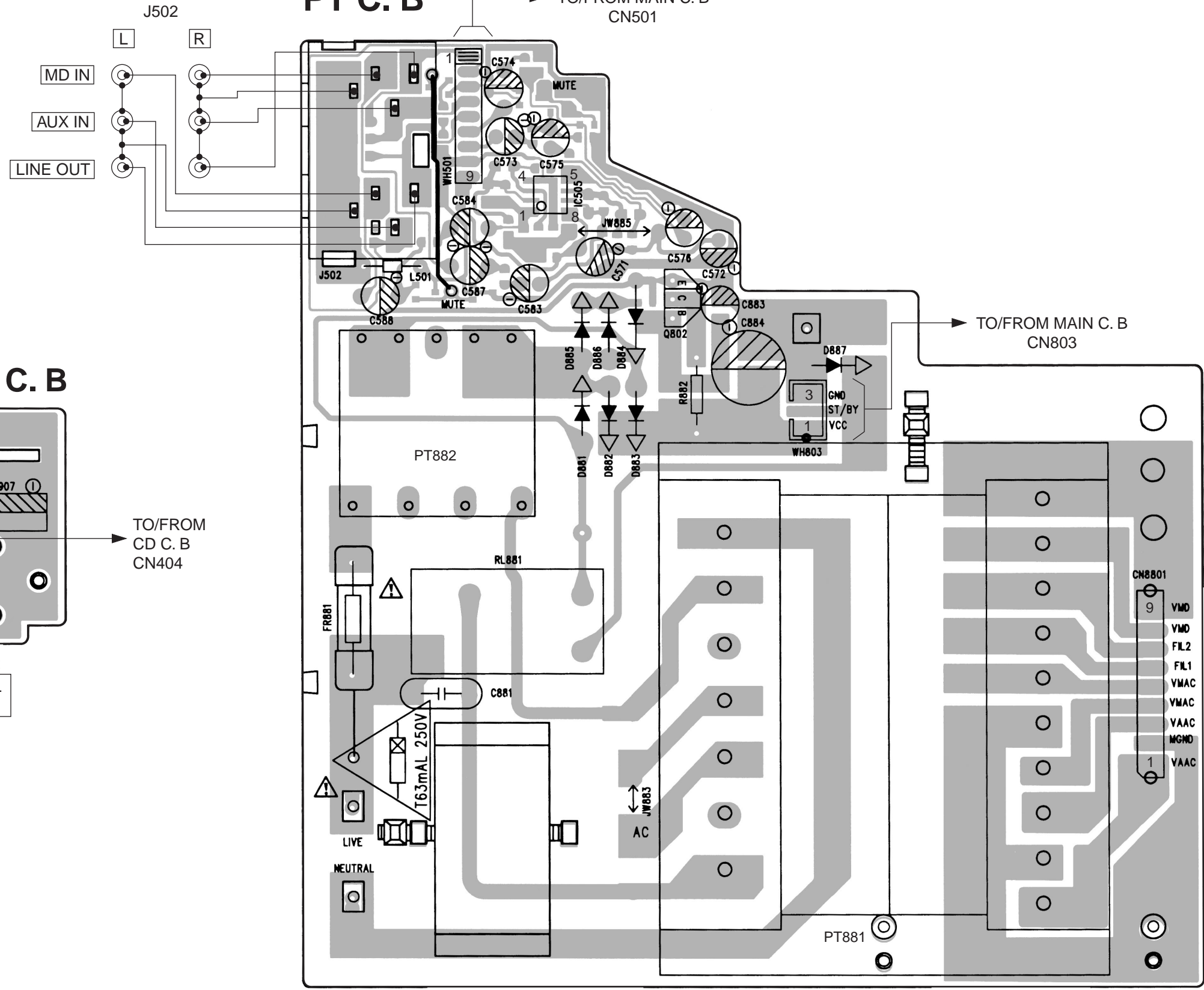

DIGITAL OUT C. B

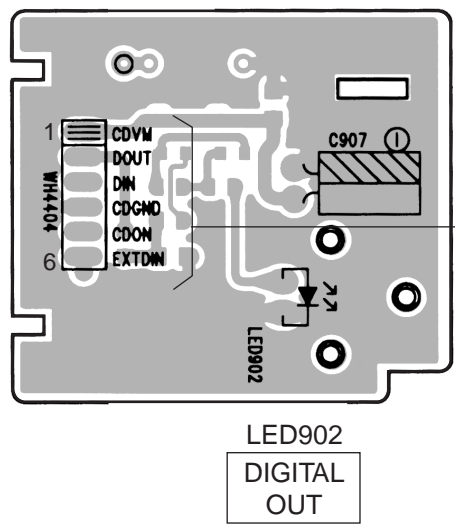

TO/FROM
CD C. B
CN404

TO/FROM MAIN C. B
CN801

1 2 3 4 5 6 7 8 9 10 11 12 13 14

A
B
C
D
E
F
G
H
I
J
K

PT C. B

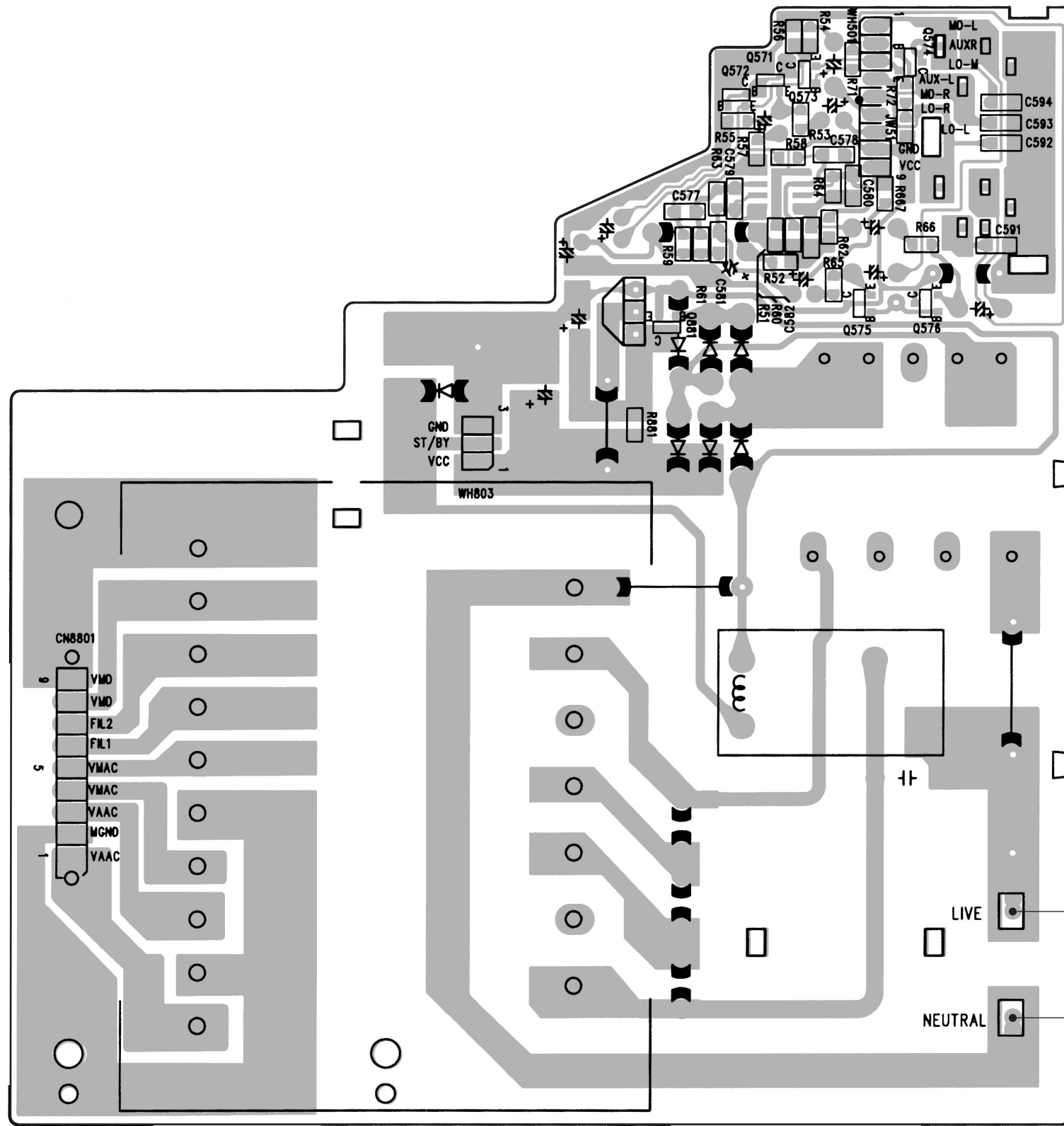

DIGITAL OUT C. B

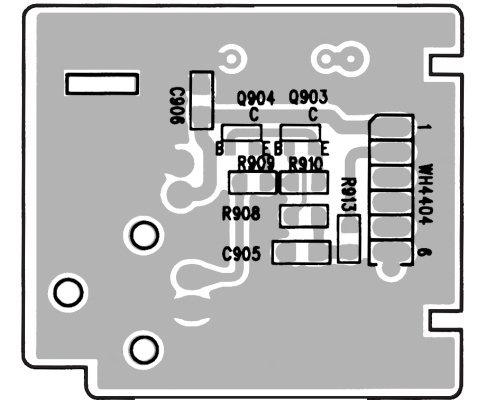

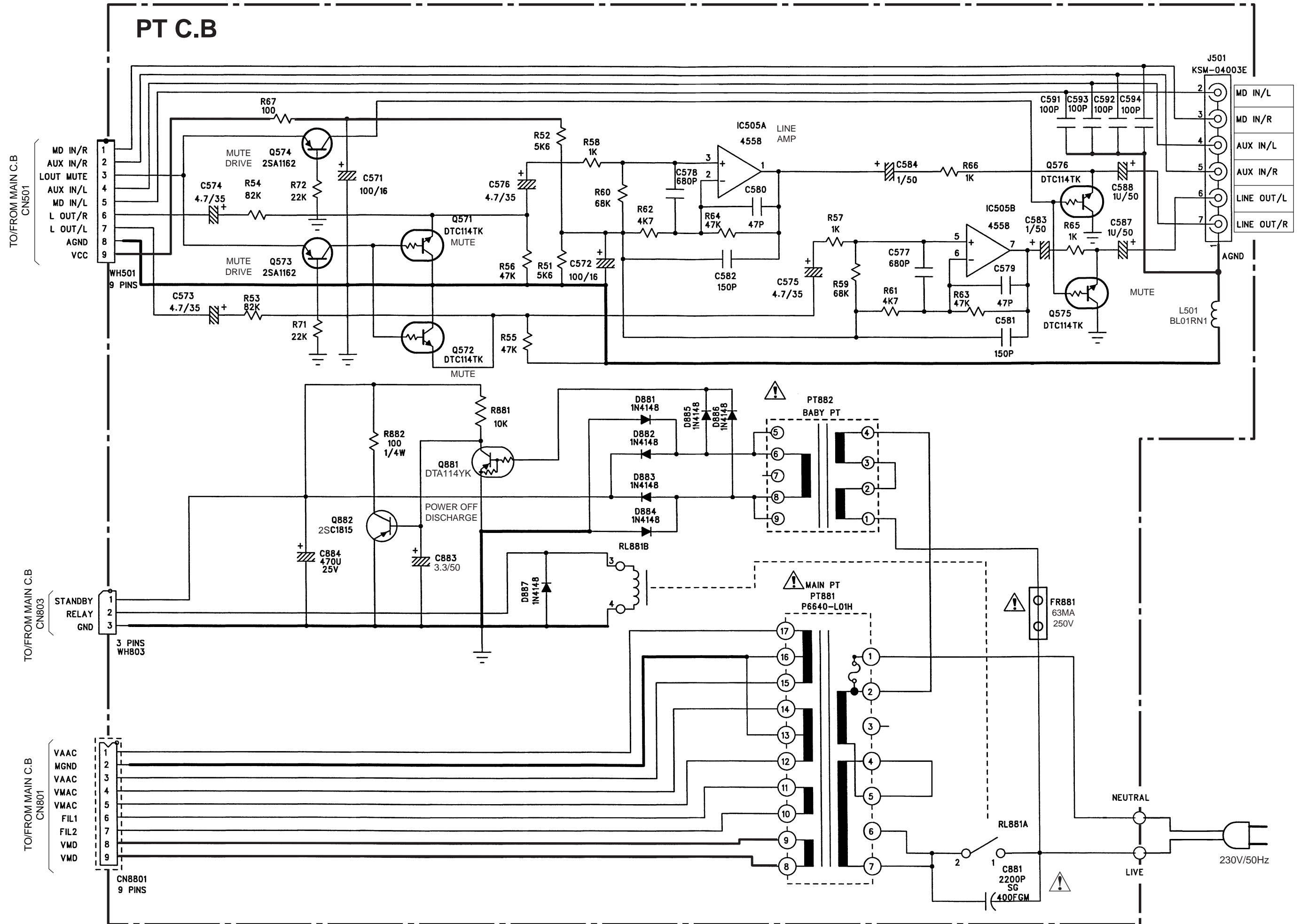

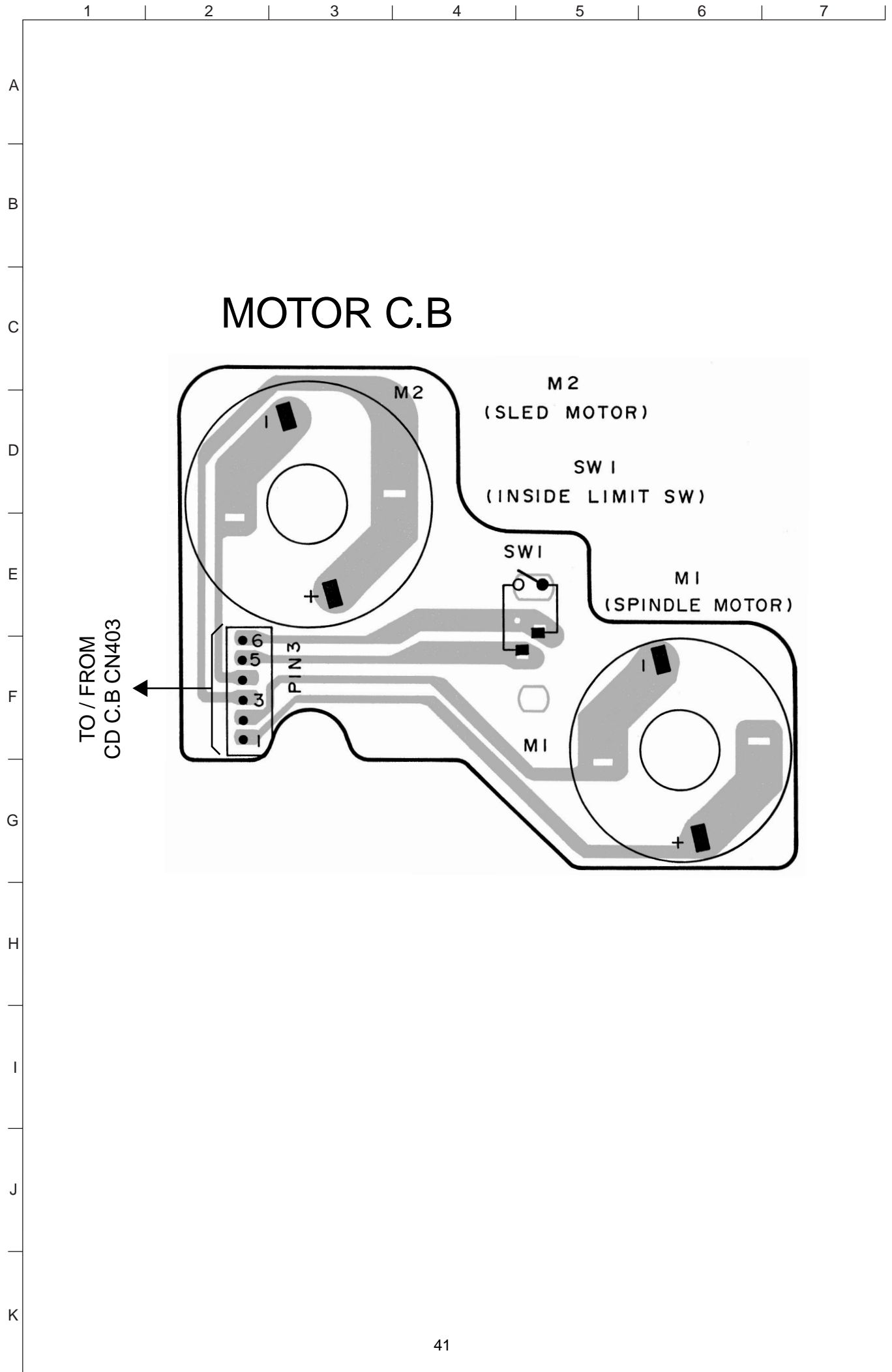

VOLTAGE CHART

THE MEASURED VALUE IS DC VOLTAGE

UNIT: V

CD SECTION

TEST CONDITION: CD PLAY

IC401 LA9241M

PIN'S NUMBER	1	2	3	4	5	6	7	8	9	10	11	12
	2.62	2.62	2.62	2.63	2.59	2.62	2.61	2.62	2.61	2.61	2.61	2.60
PIN'S NUMBER	13	14	15	16	17	18	19	20	21	22	23	24
	2.54	2.61	2.65	2.73	2.62	2.56	2.62	2.44	2.62	0	2.61	2.61
PIN'S NUMBER	25	26	27	28	29	30	31	32	33	34	35	36
	2.60	2.62	2.71	2.62	2.75	2.56	2.57	0	0	4.98	0	0
PIN'S NUMBER	37	38	39	40	41	42	43	44	45	46	47	48
	0	0	0	0.37	2.62	2.55	2.72	2.60	0	2.61	0	0
PIN'S NUMBER	49	50	51	52	53	54	55	56	57	58	59	60
	0	2.55	4.43	5.35	0	4.89	0.18	5.07	2.62	2.62	2.96	3.00
PIN'S NUMBER	61	62	63	64								
	2.32	3.85	0.27	5.07								

IC402 LC78622ED

PIN'S NUMBER	1	2	3	4	5	6	7	8	9	10	11	12
	0	0	1.63	0	2.04	5.05	0.42	0	2.59	2.73	0	0.37
PIN'S NUMBER	13	14	15	16	17	18	19	20	21	22	23	24
	0	0	0.10	0.34	0	4.98	0	0	2.48	4.98	4.99	0
PIN'S NUMBER	25	26	27	28	29	30	31	32	33	34	35	36
	0	1.80	5.02	1.73	0	0	2.52	0	0	0	0	4.92
PIN'S NUMBER	37	38	39	40	41	42	43	44	45	46	47	48
	2.15	0	0	2.14	4.93	0	4.99	2.20	2.19	0	0.18	0
PIN'S NUMBER	49	50	51	52	53	54	55	56	57	58	59	60
	0.18	2.53	0	2.53	1.72	0	0.37	5.36	4.44	4.96	0	2.49
PIN'S NUMBER	61	62	63	64								
	2.42	0	0	0								

IC404 BA5936S

PIN'S NUMBER	1	2	3	4	5	6	7	8	9	10	11	12
	3.15	3.22	2.73	3.54	2.59	2.59	6.74	6.74	6.39	5.78	5.04	0
PIN'S NUMBER	13	14	15	16	17	18	19	20	21	22	23	24
	0	3.42	3.39	0	3.07	3.15	2.80	3.39	2.59	2.59	6.78	2.59
PIN'S NUMBER	25	26	27	28	29	30	31	32				
	0	0	6.82	0	0	3.46	3.45	0				

TRANSISTOR	Q815(C2712)			Q816(A1162)			Q817(C2712)		
	E	C	B	E	C	B	E	C	B
	0	3.42	0	0	0	0.65	0	0	0.63

TRANSISTOR	Q809(2SA933)			Q810(2SA933)		
	E	C	B	E	C	B
	-32.8	-33.4	-33.5	-31.2	-33.0	-32.0

CPU SECTION
TEST CONDITION: CD PLAY
IC201 LC876572V

PIN'S NUMBER	1	2	3	4	5	6	7	8	9	10	11	12
CD PLAY	4.35	0	5.42	0.10	0	0.09	0.1	0	5.42	0.26	5.33	3.34
PIN'S NUMBER	13	14	15	16	17	18	19	20	21	22	23	24
CD PLAY	0	0	2.73	2.76	5.45	0	5.51	5.51	0	0	0	0
PIN'S NUMBER	25	26	27	28	29	30	31	32	33	34	35	36
CD PLAY	0	0	/	1.62	5.23	/	/	/	/	/	/	/
PIN'S NUMBER	37	38	39	40	41	42	43	44	45	46	47	48
CD PLAY	/	/	/	/	/	/	/	/	/	/	/	/
PIN'S NUMBER	49	50	51	52	53	54	55	56	57	58	59	60
CD PLAY	/	/	/	/	/	/	/	/	/	/	/	/
PIN'S NUMBER	61	62	63	64	65	66	67	68	69	70	71	72
CD PLAY	/	/	/	/	/	/	/	/	/	/	/	/
PIN'S NUMBER	73	74	75	76	77	78	79	80	81	82	83	84
CD PLAY	/	/	/	/	/	/	/	/	0	-30.1	0	0
PIN'S NUMBER	85	86	87	88	89	90	91	92	93	94	95	96
CD PLAY	0	0	5.39	5.37	0	5.45	0	4.51	0	0	0	0
PIN'S NUMBER	97	98	99	100								
CD PLAY	5.52	5.37	5.37	5.52								

IC202 BU2092

PIN'S NUMBER	1	2	3	4	5	6	7	8	9
TUNER	0	0.59	0.58	0	0	0	2.91	2.89	2.89
CD PLAY	0	0.58	0.58	0	0	2.99	2.90	0	2.89
PIN'S NUMBER	10	11	12	13	14	15	16	17	18
FM	0	0	0	0	0	0.39	0	0	5.72
CD PLAY	0	0	0	0	0	0.40	0	0	6

MAIN SECTION
TEST CONDITION: TUNER ON OR CD PLAY

IC504 BU4094

PIN'S NUMBER	1	2	3	4	5	6	7	8
BBE ON	0	0	0	0	0	0	10.94	0
BBE OFF	0	0	0	0	0	0	11.07	
PIN'S NUMBER	9	10	11	12	13	14	15	16
BBE ON	0	0	0	0	10.72	0	10.98	10.98
BBE OFF	0	0.00	0	0	0	0	11.11	11.11

IC501 M62495FP

PIN'S NUMBER	1	2	3	4	5	6	7	8	9	10	11	12
CD PLAY	0	0	0	0	0	0	0	0	0	0	0	2.61
PIN'S NUMBER	13	14	15	16	17	18	19	20	21	22	23	24
CD PLAY	0.27	-2.67	0	0	0	0	0	0	0	0	0	0

IC503 BA3880FS

PIN'S NUMBER	1	2	3	4	5	6	7	8	9	10	11	12
BBE ON	0	0	3.48	1.72	5.35	5.36	5.36	5.34	5.35	5.35	0	5.35
PIN'S NUMBER	13	14	15	16	17	18	19	20	21	22	23	24
BBE ON	5.34	5.35	5.35	0	5.34	5.36	0	5.36	4.39	3.61	0	0

IC801 LA4625

PIN'S NUMBER	1	2	3	4	5	6	7
	1.63	9.62	0	5.07	2.62	1.63	2.04
PIN'S NUMBER	8	9	10	11	12	13	14
	9.69	9.45	0	9.74	0	9.32	22.4

IC802 LC7805

PIN'S NUMBER	1	2	3
	4.15	0	5.08

TRANSISTOR	Q801(2SB1370E)			Q803(2SC2712)			Q804(2SC2712)		
	E	C	B	E	C	B	E	C	B
	15.57	11.90	15.16	0.17	13.66	0.82	0	0.81	0.61

TRANSISTOR	Q806(8550)			Q807(8050)			Q811(DTA144EK)		
	E	C	B	E	C	B	E	C	B
POWER ON	11.47	11.46	10.76	11.10	11.90	11.79	11.05	11.03	0.82
STANDBY	11.47	11.44	10.86	11.13	11.90	11.81	11.10	0	11.01

POWER TRANSFORMER SECTION
TEST CONDITION: TUNER ON OR CD PLAY

IC505 4558

PIN'S NUMBER	1	2	3	4	5	6	7	8
	5.41	0	5.34	0	5.33	5.38	5.41	10.75

TRANSISTOR	Q881(DTC114EK)			Q882(C1815)		
	E	C	B	E	C	B
POWER ON	0	0	8.87	0	0	0
STANDBY	0	0	8.87	1.61	1.59	0.99

ELECTRICAL ADJUSTMENT

< CD SECTION >

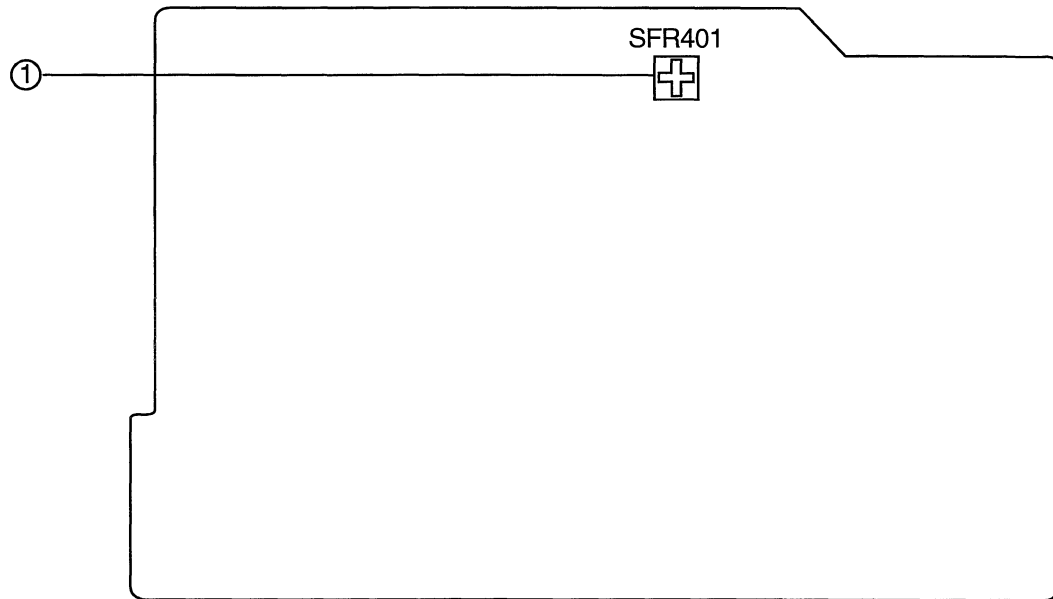

ZCL5/F-01-05 TOP VIEW

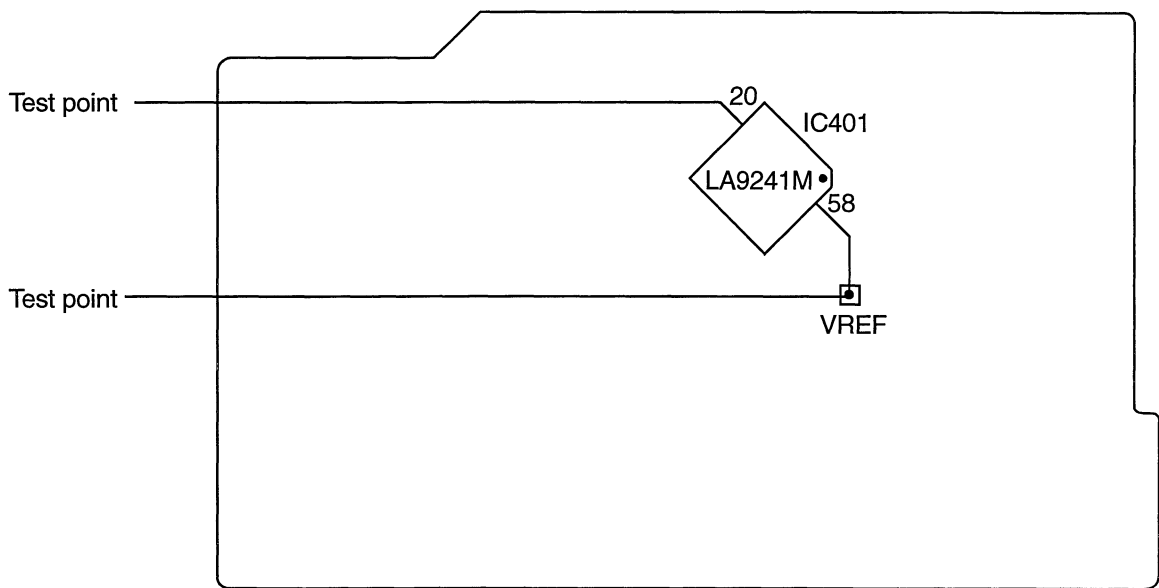

ZCL5/F-01-05 BOTTOM VIEW

- 1 FO Adjustment
Test point: IC401 (LA9241M) 20PIN and 58PIN.
- 1) Connect an oscilloscope to the test points.
- 2) Turn on the power switch.
- 3) Load the test disc (TCD-782) and play.
- 4) Adjust SFR401 so that level is 0dB.
- 5) Turn off the power switch and take out the disc.

< TUNER SECTION >

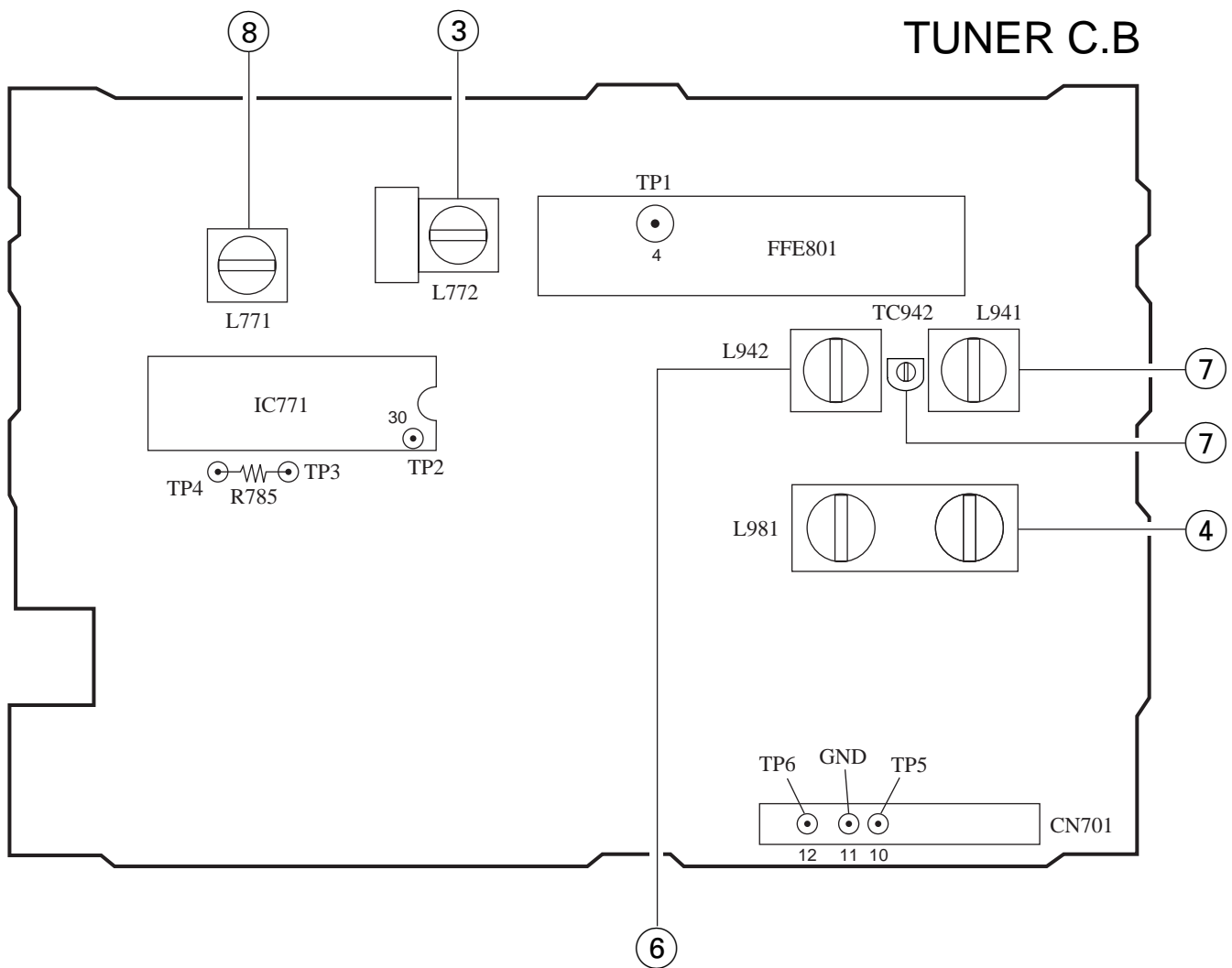

PRACTICAL SERVICE FIGURE

< TUNER SECTION >

< FM SECTION >

IHF Sensitivity: (THD 3%)	Less than 14dB (at 88.0/98.0MHz) Less than 16dB (at 108.0MHz)
Distortion: (input 66dB)	Less than 1.5% (98.0MHz)
Stereo separation:	More than 16dB (98.0MHz)
Intermediate frequency:	10.7MHz

< MW SECTION >

Sensitivity: (S/N 20dB)	Less than 60dB (at 603kHz) Less than 58dB (at 999/1404kHz)
Distortion: (input 74dB)	Less than 2% (at 999kHz)

< LW SECTION >

Sensitivity: (S/N 20dB)	Less than 76dB (at 153kHz) Less than 71dB (at 198kHz) Less than 69dB (at 279kHz)
Distortion: (input 80dB)	Less than 3% (at 198kHz)

- Clock Frequency Check**
 Settings: • Test point: TP2 (CLK IC770 pin30)
 Method: Set to MW 1602kHz and check that the test point becomes 2052kHz±45Hz (EZ).
- MW VT Check**
 Settings: • Test point: TP1 (VT)
 Method: Set to MW 1602kHz and check that the test point is less than 8.0V.
 Then set to MW 531kHz and check that the test point is more than 0.6V.
- MW IF Adjustment**
 Settings: • Test point: TP5, TP6
 L772 450kHz
- MW Tracking Adjustment**
 Settings: • Test point: TP5, TP6
 • Adjustment location: L981
 Method: Set to MW 999kHz and adjust L981 so that the test point becomes maximum.
- FM VT Check**
 Settings: • Test point: TP1 (VT)
 Method: Set to FM 87.5MHz, 108.0MHz and check that the test point is more than 0.5V (87.5MHz) and less than 8.0V (108.0MHz).
- LW VT Adjustment**
 Settings: • Test point: TP2 (VT)
 • Adjustment location: L942
 Method: Set to LW 144kHz and adjust L942 so that the test point becomes 1.3V±0.05V.
 Then set to LW 290kHz and check that the test point is less than 8.0V.
- LW Tracking Adjustment**
 Settings: • Test point: TP5, TP6
 • Adjustment location:
 L941 144kHz
 TC942 290kHz
 Method: Set up TC942 to center before adjustment.
 The level at 144kHz is adjusted to MAX by L941. Then the level at 290kHz is adjusted to MAX by TC942.
- DC Balance/Mono Distortion Adjustment**
 Settings: • Test point: TP3, TP4
 • Adjustment location: L771
 • Input level: 54dB
 Method: Set to FM 98.0MHz and adjust L771 so that the voltage between TP3 and TP4 becomes 0V±0.04V.
 Next, check that the distortion is less than 1.3%.

IC DESCRIPTION

IC, LC876564

Pin No.	Pin Name	I/O	Description
1	I-STEREO/DRF	I	Connected to stereo detection and tuner CD ASP LA9241ML pin-54 DRF.
2	I-TUDO/I-SQOUT	I	Connected to tuner PLL IC LC72131 pin-⑥ DO and connected to CD DSP LC78622ED pin-55 SQOUT.
3	I-RSDATA/O-COIN	I	Connected to RDS data input CD DSP LC78622ED pin-56 COIN and CD ASP LA9241ML pin-52 DAT.
4	O-F.LED	O	Function LED control output.
5	O-M.STB	O	Connected to main shift resistor 4094 pin-① STB.
6	O-CLK	O	Connected to front shift resistor BU2092 pin-③ CLK, main shift resistor 4094 pin-③ CLK, and tuner PLL IC LC72131 pin-⑤ CL.
7	O-DATA	O	Connected to front shift resistor BU2092 pin-② DATA, main shift resistor 4094 pin-② DATA, and tuner PLL IC LC72131 pin-④ DI.
8	O-VOLCTL	O	Connected to VOL/P.EQ IC M62439SP pin-⑪ CONT.
9	I-TMBASE	I	Reference clock input for clock PLL IC LC72131 pin-⑦.
10	O-CKSFT	O	Clock shift output is shifted: "L"
11	RESET	I/O	Microprocessor reset.
12	I-ACOFF	I	Hold status detection.
13	I-TU-SIG/I-MS	I	RDS signal level AD value input, and CD ASP LA9241ML pin-52 DAT.
14	VSS	—	GND.
15	CF1	—	Connected to 5.76 MHz oscillator
16	CF2	—	Connected to 5.76 MHz oscillator.
17	VDD1	—	Microprocessor power supply. (μ-com 5 V)
18	N.C	—	Not connected.
19	I-KEY1	I	Key AD value input.
20	I-KEY0	I	Key AD value input.
21	I-DSW	I	Deck MECA status detection input. (AD)
22	I-CDTSW	I	CD tray OPEN/CLOSE status detection input. (AD)
23	I-ENC1	I	AD value input from multiple jog rotary encoder outputs A and B.
24	M SENSOR	I	Electronic VOL's AD value input from rotary encoder outputs A and B.
25	O-CE	O	Connected to tuner PLL IC LC72131 pin-③ CE.
26	N.C.	—	Not connected.
27	I-LEVEL	I	Level meter input.
28	I-RDS-CLK/I-WRQ	I	Connected to RDS CLK input and CD DSP LC78622ED pin-53 WRQ.
29	I-RMC	I	Remote control input.
30-42	G1-G13	O	FL tube grid output.
43-45	P33-P35	O	FL tube anode output.
46	VDD3	—	Microprocessor power supply. (μ-com 5 V)
47-50	P29-P32	O	FL tube anode output.
51	VP	—	Connected to minus power supply for FL, -VFL.
52-63	P17-P28	O	FL tube anode output.
64	P16/BBE	O	FL tube anode output, and INT.DIODE MATRIX input.
65	P15/DOLBY	O	FL tube anode output, and INT.DIODE MATRIX input.

Pin No.	Pin Name	I/O	Description
66	P14/AM WIDE	O	FL tube anode output, and INT.DIODE MATRIX input.
67	P13/FM WIDE	O	FL tube anode output, and INT.DIODE MATRIX input.
68	P12/LW	O	FL tube anode output, and INT.DIODE MATRIX input.
69	P11/SW	O	FL tube anode output, and INT.DIODE MATRIX input.
70	P10/OIRT	O	FL tube anode output, and INT.DIODE MATRIX input.
71	P9/RDS	O	FL tube anode output, and INT.DIODE MATRIX input.
72	VDD4	—	Microprocessor power supply. (μ -com 5 V)
73-78	P3-P8	O	FL tube anode output. /SHOP
79	P2/CAM	O	Deck mechanism status detection input. (CAM)
80	P1/AUTO	O	Deck mechanism status detection input. (AUTO)
81	O-QSURR	O	Q-surround IC control output.
82	O-SWSCAN	O	Key scan detection timing switch.
83	O-MOTOR	O	Deck mechanism motor control output.
84	O-FSTB	O	Connected to front shift resistor IC BU2092 pin-⑤.
85	O-CDOPEN	O	CD tray open control output.
86	O-CDCLOSE	O	CD tray close control output.
87	O-POWER	O	Power supply ON/OFF control.
88	O-MDRST	O	MD unit 7ZG-9A reset signal output.
89	VSS2	—	GND.
90	VDD2	—	Microprocessor power supply. (μ -com 5 V)
91	O-RWC	O	Connected to CD DSP LC78622ED pin-54 RWC and CD ASP LA9241ML pin-53 CE.
92	O-CQCK	O	Connected to CD DSP LC78622ED pin-57 CQCK and CD ASP LA9241ML pin-51 CL.
93	O-MUTE	O	Main mute output.
94	O-PL	O	Deck mechanism plunger solenoid control output.
95-100	N.C.	—	Not connected.

IC, LA9241ML

Pin No.	Pin Name	I/O	Description
1	FIN2	I	Pin to which external pickup photo diode is connected. RF signal is created by adding with the FIN1 pin signal. FE signal is created by subtracting from the FIN1 pin signal.
2	FIN1	I	Pin to which external pickup photo diode is connected.
3	E	I	Pin to which external pickup photo diode is connected. TE signal is created by subtracting from the F pin signal.
4	F	I	Pin to which external pickup photo diode is connected.
5	TB	I	DC component of the TE signal is input.
6	TE-	I	Pin to which external resistor setting the TE signal gain is connected between the TE pin.
7	TE	O	TE signal output pin.
8	TESI	I	TES "Track Error Sense" comparator input pin. TE signal is passed through a band-pass filter then input.
9	SCI	I	Shock detection signal input pin.
10	TH	I	Tracking gain time constant setting pin.
11	TA	O	TA amplifier output pin.
12	TD-	I	Pin to which external tracking phase compensation constants are connected between the TD and VR pins.
13	TD	I	Tracking phase compensation setting pin.
14	JP	I	Tracking jump signal (kick pulse) amplitude setting pin.
15	TO	O	Tracking control signal output pin.
16	FD	O	Focusing control signal output pin.
17	FD-	I	Pin to which external focusing phase compensation constants are connected between the FD and FA pins.
18	FA	I	Pin to which external focusing phase compensation constants are connected between the FD- and FA- pins.
19	FA-	I	Pin to which external focusing phase compensation constants are connected between the FA and FE pins.
20	FE	O	FE signal output pin.
21	FE-	I	Pin to which external FE signal gain setting resistor is connected between the FE pin.
22	AGND	—	Analog signal GND.
23	NC	—	No connection.
24	SP	O	Single ended output of the CV+ and CV- pin input signal.
25	SPG	I	Pin to which external spindle gain setting resistor in 12 cm mode is connected.
26	SP-	I	Pin to which external spindle phase compensation constants are connected together with SPD pin.
27	SPD	O	Spindle control signal output pin.
28	SLEQ	I	Pin to which external sled phase compensation constants are connected.
29	SLD	O	Sled control signal output pin.
30, 31	SL-, SL+	I	Sled advance signal input pin from microprocessor.
32, 33	JP-, JP+	I	Tracking jump signal input pin from DSP.
34	TGL	I	Tracking gain control signal input from DSP. Low gain when TGL = H.
35	TOFF	I	Tracking off control signal input pin from DSP. Off when TOFF = H.

Pin No.	Pin Name	I/O	Description
36	TES	O	Pin from which TES signal is output to DSP.
37	HFL	O	“High Frequency Level” is used to judge whether the main beam position is on top of bit or on top of mirror.
38	SLOF	I	Sled servo off control input pin.
39, 40	CV-, CV+	I	CLV error signal input pin from DSP.
41	RFSM	O	RF output pin.
42	RFS-	I	RF gain setting and EFM signal 3T compensation constant setting pin together with RFSM pin.
43	SLC	O	“Slice Level Control” is the output pin which controls the RF signal data slice level by DSP.
44	SLI	I	Input pin which control the data slice level by the DSP.
45	DGND	—	Digital system GND.
46	FSC	O	Output pin to which external focus search smoothing capacitor is connected.
47	TBC	I	“Tracking Balance Control” EF balance variable range setting pin.
48	NC	—	No connection.
49	DEF	O	Disc defect detector output pin.
50	CLK	I	Reference clock input pin. 4.23 MHz of the DSP is input.
51	CL	I	Microprocessor command clock input pin.
52	DAT	I	Microprocessor command data input pin.
53	CE	I	Microprocessor command chip enable input pin.
54	DRF	O	“Detect RF” RF level detector output.
55	FSS	I	“Focus Search Select” focus search mode (\pm search/+ search) select pin.
56	VCC2	—	Servo system and digital system Vcc pin.
57	REFI	—	Pin to which external bypass capacitor for reference voltage is connected.
58	VR	O	Reference voltage output pin.
59	LF2	I	Disc defect detector time constant setting pin.
60	PH1	I	Pin to which external capacitor for RF signal peak holding is connected.
61	BH1	I	Pin to which external capacitor for RF signal bottom holding is connected.
62	LDD	O	APC circuit output pin.
63	LDS	I	APC circuit input pin.
64	VCC1	—	RF system Vcc pin.

IC, LC78622ED

Pin No.	Pin Name	I/O	Description	
1	DEFI	I	Defect sense signal (DEF) input pin. (Connect to 0V when not used).	
2	TAI	I	For PLL.	Test signal input pin with built-in pull-down resistor. Be sure to connect to 0V.
3	PDO	O		Phase comparator output pin to control external VCO.
4	VVSS	—		GND pin for built-in VCO. Be sure to connect to 0V.
5	ISET	I		Pin to which external resistor adjusting the PDO output current.
6	VVDD	—		Power supply pin for built-in VCO.
7	FR	I		Pin for VCO frequency range adjustment.
8	VSS	—	Digital system GND. Be sure to connect to 0V.	
9	EFMO	O	For slice level control.	EFM signal output pin.
10	EFMIN	I		EFM signal input pin.
11	TEST2	I	Test signal input pin with built-in pull-down resistor. Be sure to connect to 0V.	
12, 13	CLV+, CLV-	O	Disc motor control output. Three level output is possible using command.	
14	V/P	O	Rough servo or phase control automatic selection monitoring output pin. Rough servo at H. Phase servo at L.	
15	HFL	I	Track detect signal input pin. Schmidt input.	
16	TES	I	Tracking error signal input pin. Schmidt input.	
17	TOFF	O	Tracking OFF output pin.	
18	TGL	O	Tracking gain selection output pin. Gain boost at L.	
19, 20	JP+, JP-	O	Track jump control signal output pin. Three level output is possible using command.	
21	PCK	O	EFM data playback clock monitoring pin 4.3218 MHz when phase is locked in.	
22	FSEQ	O	Sync signal detection output pin. H when the sync signal which is detected from EFM signal and the sync signal which is internally generated agree.	
23	VDD	—	Digital system power supply pin.	
24-28	SL+ - PUIN	I/O	General purpose input/output pin 1 to 5.	The pin is controlled by the serial data command from microprocessor. When the pin is not used, set the pin to the input terminal and connect to 0V, or alternately set the pin to output terminal and leave the pin open.
29	EMPH	O	De-emphasis monitor output pin. De-emphasis disc is being played back at H.	
30	C2F	O	C2 flag output pin.	
31	DOUT	O	DIGITAL OUT output pin. (EIAJ format).	
32, 33	TEST3, TEST4	I	Test signal input pin with built-in pull-down resistor. Be sure to connect to 0V.	
34	N.C.	—	Not used. Set the pin to open.	
35	MUTEL	O	L-channel 1-bit DAC.	L-channel mute output pin.
36	LVDD	—		L-channel power supply pin.
37	LCHO	O		L-channel output pin.
38	LVSS	—		L-channel GND. Be sure to connect to 0V.
39	RVSS	—	R-channel 1-bit DAC.	R-channel GND. Be sure to connect to 0V.
40	RCHO	O		R-channel output pin.
41	RVDD	—		R-channel power supply pin.
42	MUTER	O		R-channel mute output pin.

Pin No.	Pin Name	I/O	Description
43	XVDD	—	Crystal oscillator power supply pin.
44	XOUT	O	Pin to which external 16.9344 MHz crystal oscillator is connected.
45	XIN	I	
46	XVSS	—	Crystal oscillator GND pin. Be sure to connect to 0V.
47	SBSY	O	Subcode block sync signal output pin.
48	EFLG	O	C1, C2, single and dual correction monitoring pin.
49	PW	O	Subcode P, Q, R, S, T, U and W output pin.
50	SFSY	O	Subcode frame sync signal output pin. Falls down when subcode enters standby.
51	SBCK	I	Subcode read clock input pin. Schmidt input. (Be sure to connected to 0V when not in use.)
52	FSX	O	Pin outputting the 7.35 kHz sync signal which is generated by dividing frequency of crystal oscillator.
53	WRQ	O	Subcode Q output standby output pin.
54	RWC	I	Read/write control input pin. Schmidt input.
55	SQOUT	O	Subcode Q output pin.
56	COIN	I	Command input pin from microprocessor.
57	\overline{CQCK}	I	Command input read clock or subcode read input clock from SQOUT pin
58	\overline{RES}	I	LC78622 reset input pin. Set this pin to L once when the main power is turned on.
59	TST11	O	Test signal output pin. Use this pin as open (normally L output).
60	16M	O	16.9344 MHz output pin.
61	4.2M	O	4.2336 MHz output pin.
62	TEST5	I	Test signal input pin with built-in pull-down resistor. Be sure to connect to 0V.
63	\overline{CS}	I	Chip select signal input pin with built-in pull-down resistor. Be sure to connect to 0V while it is not controlling.
64	TEST1	I	Test signal input pin without built-in pull-down resistor. Be sure to connect to 0V.

Note: The same potential must be applied to the respective power supply terminals. (VDD, VVDD, LVDD, RVDD, XVDD)

IC BLOCK DIAGRAM

IC, BU4094BCF

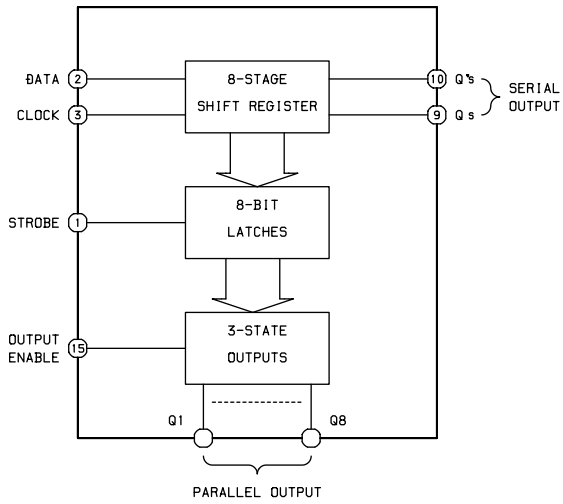

TRUTH TABLE

CLOCK	OUTPUT ENABLE	STROBE	DATA	PARALLEL OUTPUTS		SERIAL OUTPUTS	
				Q ₁	Q _n	Q _s	Q _s
$\overline{\text{Clock}}$	L	X	X	Z	Z	Q ₇	NO Chg.
$\overline{\text{Clock}}$	L	X	X	Z	Z	No Chg.	Q _s
$\overline{\text{Clock}}$	H	L	X	No Chg.	No Chg.	Q ₇	No Chg.
$\overline{\text{Clock}}$	H	H	L	L	Q _{n-1}	Q ₇	No Chg.
$\overline{\text{Clock}}$	H	H	H	H	Q _{n-1}	Q ₇	No Chg.
$\overline{\text{Clock}}$	H	X	X	No Chg.	No Chg.	No Chg.	Q _s

Z=High Impedance
X=Don't Care

IC, BA3880FS

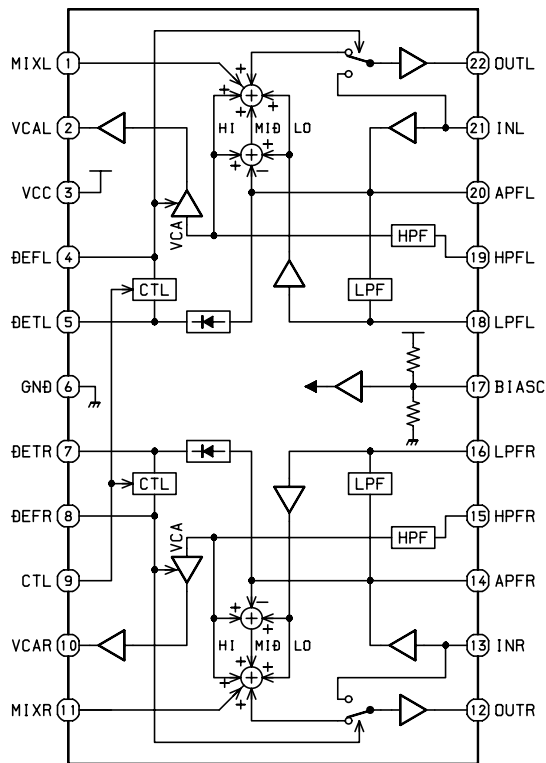

IC, BU2092

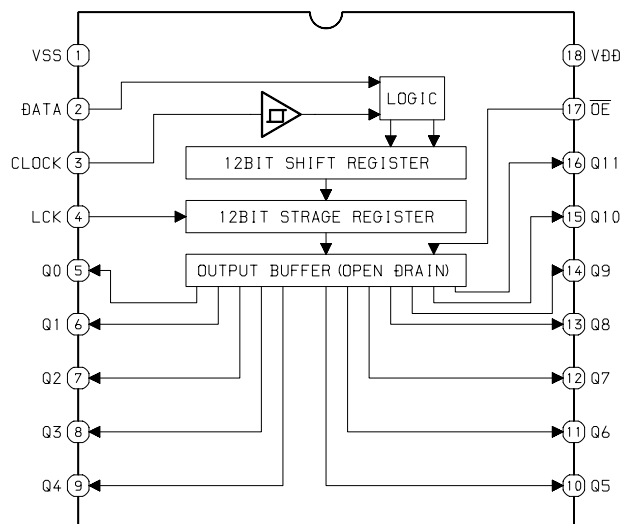

IC, LA4663

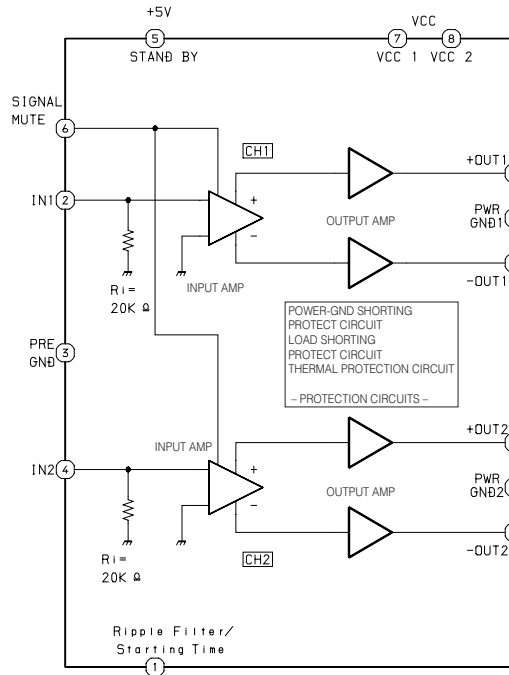

IC, M62495FP

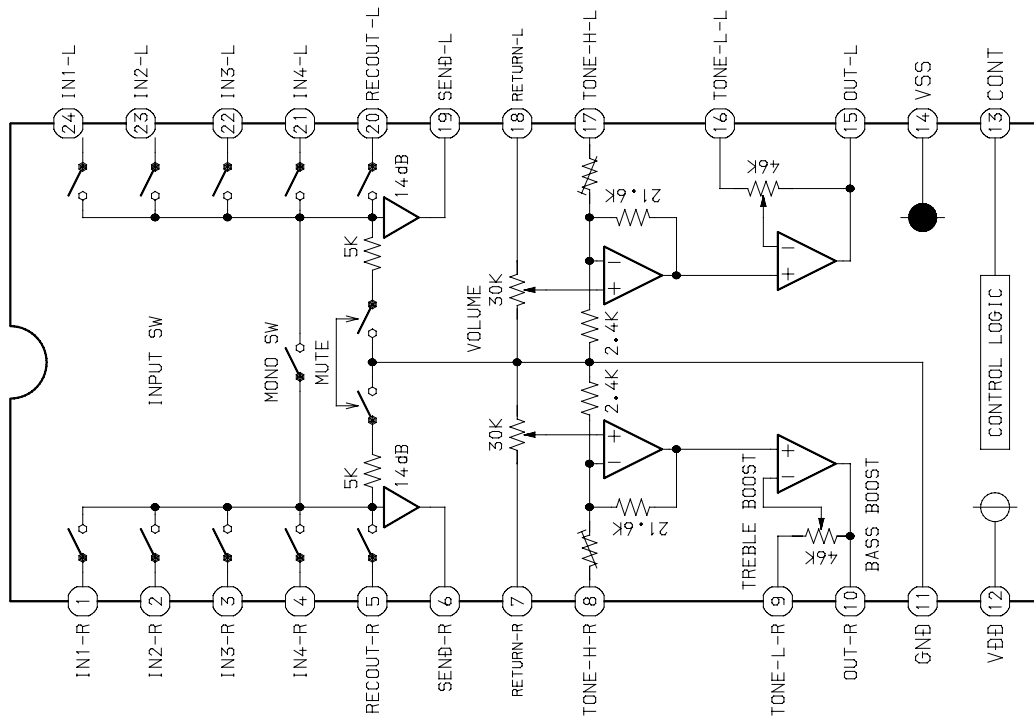

IC, BA5936

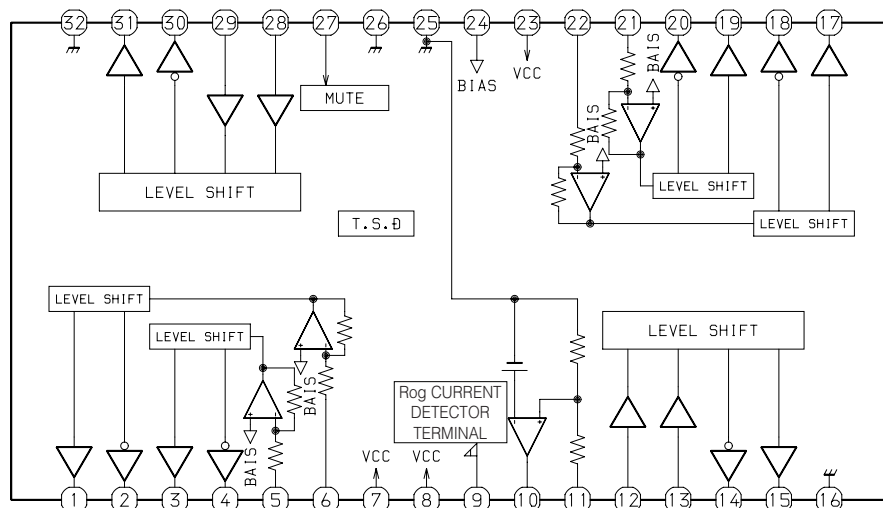

MECHANICAL PARTS LIST 1/1

DESCRIPTIONで判断できない物は "REFERENCE NAME LIST" を参照してください。
If can't understand for Description please kindly refer to "REFERENCE NAME LIST".

REF. NO	PART NO.	KANRI NO.	DESCRIPTION	REF. NO	PART NO.	KANRI NO.	DESCRIPTION
1	8Z-CL5-030-010		WINDOW, FL E<EVS>	39	8Z-NB8-240-010		COVER, PL
1	8Z-CL5-009-010		WINDOW, FL SUH<KS>	40	8Z-CL5-221-010		HLDR, BKT MOUNT
2	8Z-CL5-211-010		PANEL, CD	41	8Z-CL5-622-010		F-CABLE, 9P 2.5 250MM UL2468 AW
3	8Z-CLF-007-010		CABI, FRONT E<EVS>	42	8Z-CL5-621-010		FF-CABLE, 13P 1.0 220MM
3	8Z-CLF-006-010		CABI, FRONY UH<KS>	43	8Z-CL5-603-010		FF-CABLE, 7P 1.0 150MM UL2896
4	8Z-CL5-014-010		BTN, SET POWER	44	8Z-CL5-604-010		FF-CABLE, 16P 1.0 100MM
5	8Z-CL5-016-010		BTN, POWER	45	87-A80-092-010		AC CORD ASSY, E BLK SUN FAI<EVS>
6	8Z-CL5-020-010		BTN, CRYSTAL TU	45	87-A80-108-010		AC CORD ASSY, K BLK 3P<KS>
7	8Z-CL5-021-010		BTN, CRYSTAL AX	46	SZ-CL5-540-000		CD BRACKET COVER
8	8Z-CL5-022-010		BTN, CRYSTAL CD	47	8Z-CL5-037-010		BADGE, AIWA
9	8Z-CL5-023-010		BTN, CRYSTAL MD	48	8Z-CL5-215-010		PLATE, MTG TX
10	8Z-CL5-015-010		BTN, SET FUNC	49	SZ-CL5-63X-XX0		CD DOOR PLATE
11	8Z-CL5-013-010		BTN, SET CD	50	S0-075-380-000		MAGNET
12	8Z-CL5-018-010		BTN, CD OPEN	51	8Z-CLF-004-010		PLATE, DECO E<EVS>
13	8Z-CLF-018-010		BTN, SET ENTER	51	8Z-CLF-003-010		PLATE, DECO SUH<KS>
14	8Z-CLF-001-010		PANEL, CONT S FA	52	8Z-CL5-214-010		HLDR, (B) PWB TU
15	8Z-CL5-019-010		BTN, JOG	53	S3-026-060-400		WASHER, 2.6X6X0.4MM
16	8Z-CL5-217-010		BELT, PULLEY	54	86-CT4-228-010		WASHER, DIA: 3.2X8X1
17	8Z-CL5-205-010		PULLEY, GEAR CD	55	S3-035-080-400		WASHER, 3.5X8X0.4MM
18	8Z-CL5-206-010		GEAR, MID CD	56	88-CL1-215-010		WASHER, 4.4X10X1MM
19	8Z-CL5-207-010		GEAR, CD	57	SZ-CL5-590-000		PC COVER PLATE
20	8Z-CL5-203-010		HLDR, GEAR CD	A	87-743-074-410		ST2.6X8MM, PAB
21	8Z-CL5-208-010		PULLEY, MOTOR	B	87-251-092-410		SCREW M3X4
22	8Z-CLF-002-010		PANEL, FRONT S FA	C	87-741-096-410		SCREW, 3X10MM, KM BRASS BASED
23	88-CH6-220-010		CUSHION, CD A	D	87-741-095-410		ST3X8MM, BB HEAD
24	8Z-CL5-627-010		F-CABLE, 5P 2.5 250MM UL2468 AW	E	87-741-097-410		ST3X12MM, KAB
25	8Z-CL5-204-010		HLDR, CD CHUCK	F	87-741-172-410		ST4X12MM, PM
26	88-CD9-210-010		BASE, CHUCK	G	87-741-095-410		ST3X8MM, BB
27	88-CD9-211-010		RING, CHUCK	H	87-067-964-010		SCREW, 3X6MM PB
28	8Z-CL5-201-010		GUIDE, LED	I	87-253-035-101		SCREW, 2X6MM PB
29	8Z-CL5-210-010		CHAS, CD	J	87-641-101-410		SCREW 2.6X17MM BB
30	8Z-CL5-005-010		LID, CD	K	87-253-095-410		SCREW, 3X8 BB BRASS BASED
31	8Z-CL5-008-010		WINDOW, CD	L	87-254-033-410		SCREW, 2X4MM, BM
32	8Z-CL5-003-010		CABI, SIDE R	M	87-067-767-010		SCREW, 2.6X6MM, PM BRASS BASED
33	8Z-CL5-683-010		PT, E	N	87-B10-026-010		SCREW, 1.7X8MM
34	8Z-CL5-213-010		HLDR, (A) PWB TU	O	87-253-035-410		ST 2X6MM, PM BRASS BASED
35	8Z-CL5-216-010		FOOT, CABI				
36	8Z-CLF-010-010		CABI, REAR E				
37	8Z-CL5-004-010		CABI, SIDE L				
38	87-085-185-010		BUSHING, AC CORD (E)				

COLOR NAME TABLE

Basic color symbol	Color	Basic color symbol	Color	Basic color symbol	Color
B	Black	C	Cream	D	Orange
G	Green	H	Gray	L	Blue
LT	Transparent Blue	N	Gold	P	Pink
R	Red	S	Silver	ST	Titan Silver
T	Brown	V	Violet	W	White
WT	Transparent White	Y	Yellow	YT	Transparent Yellow
LM	Metallic Blue	LL	Light Blue	GT	Transparent Green
LD	Dark Blue	DT	Transparent Orange		

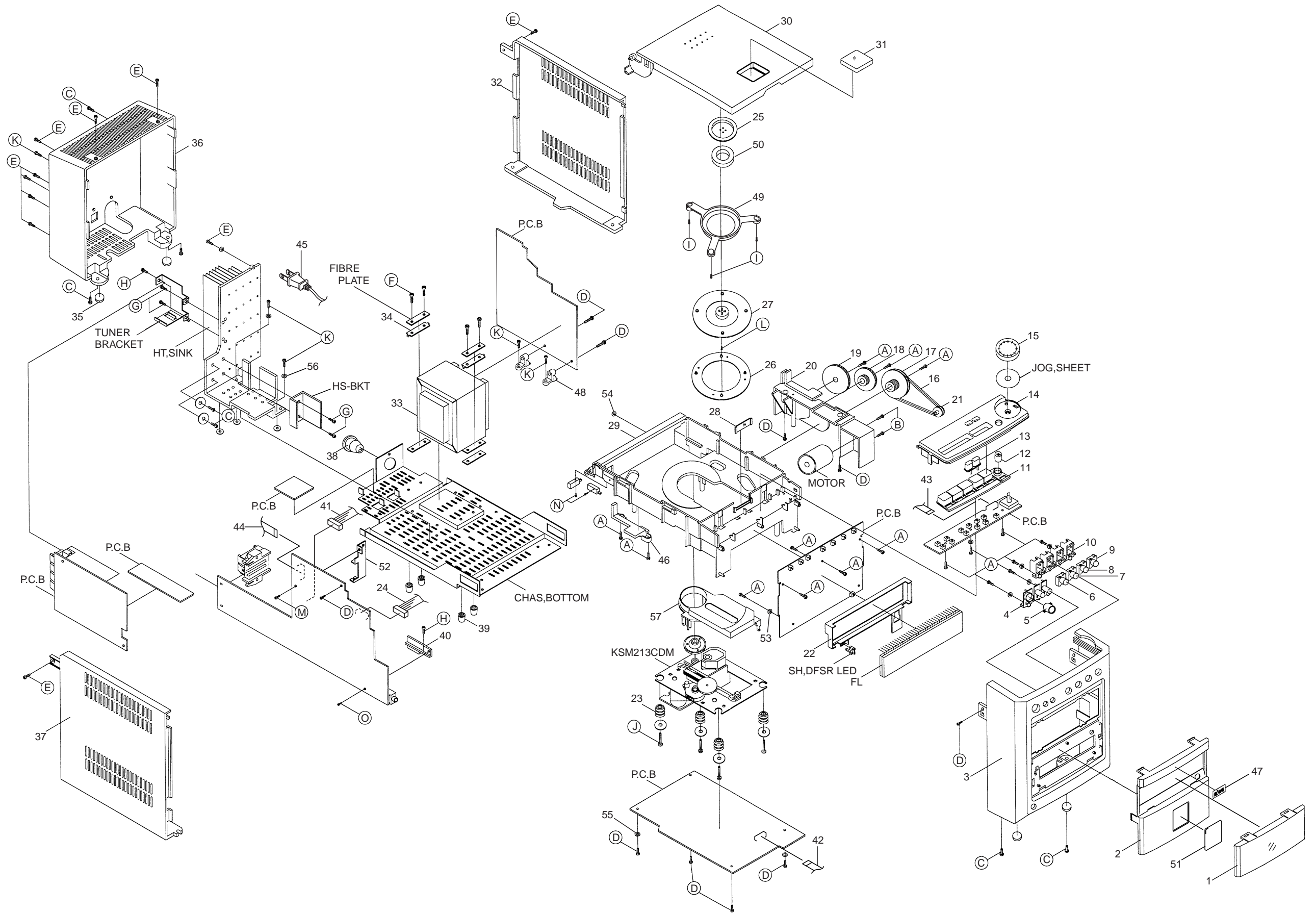

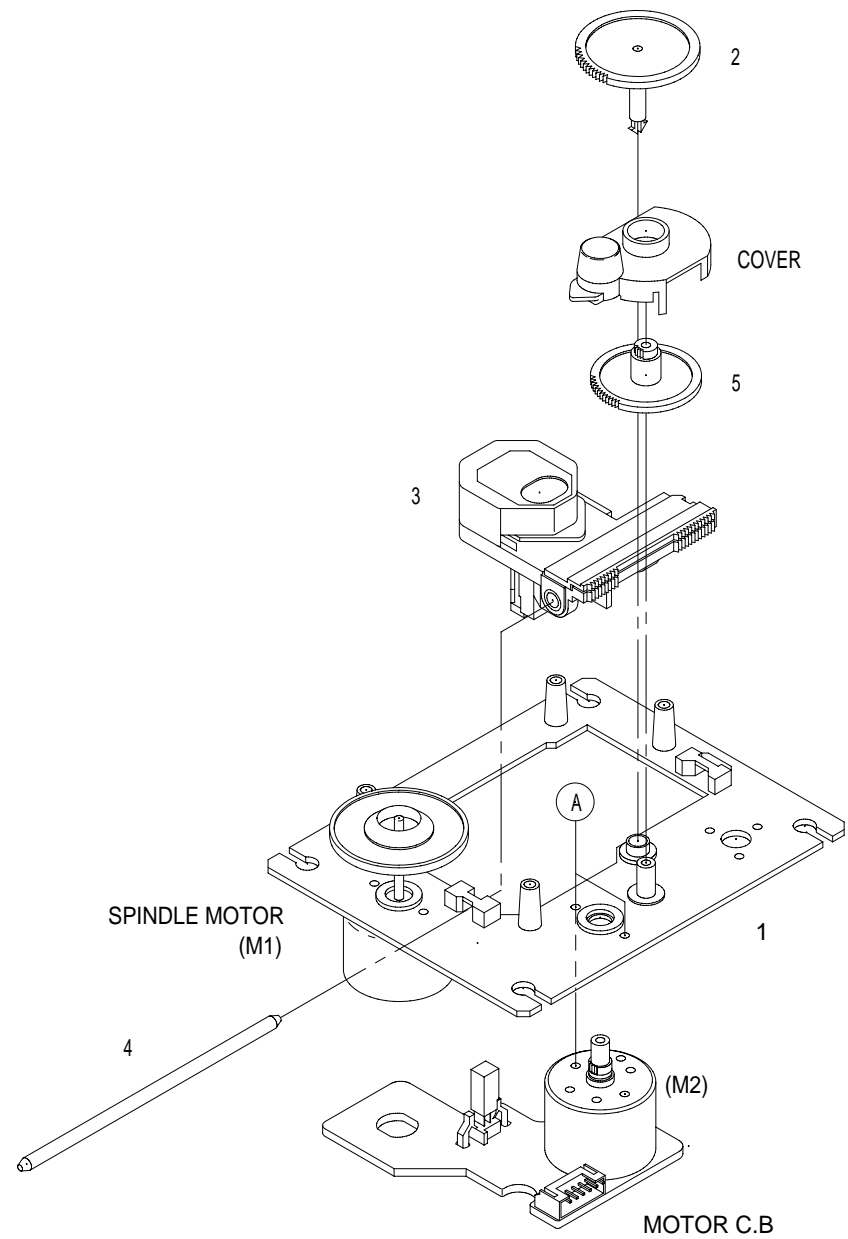

CD MECHANISM PARTS LIST 1/1

DESCRIPTIONで判断できない物は "REFERENCE NAME LIST" を参照してください。
If can't understand for Description please kindly refer to "REFERENCE NAME LIST".

REF. NO	PART NO.	KANRI NO.	DESCRIPTION
1	9X-262-620-210		MOTOR CHASSIS ASSY
2	92-626-907-010		GEAR (A)
3	87-A90-468-010		PICK UP KSS-213C
4	92-626-908-010		SHAFT SLED
5	92-627-003-020		GEAR (B) (RP)
A	97-621-255-150		SCREW+P2-3

SPEAKER DISASSEMBLY INSTRUCTIONS

Type.1

Insert a flat-bladed screwdriver into the position indicated by the arrows and remove the panel. Remove the screws of each speaker unit and then remove the speaker units.

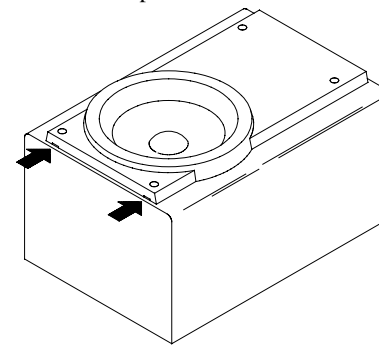

Type.2

Remove the grill frame and four pieces of rubber caps by pulling out with a flat-bladed screwdriver. Remove the screws from hold where installed rubber caps. Insert a flat-bladed screwdriver into the position indicated by the arrows and remove the panel. Remove the screws of each speaker unit and then remove the speaker units.

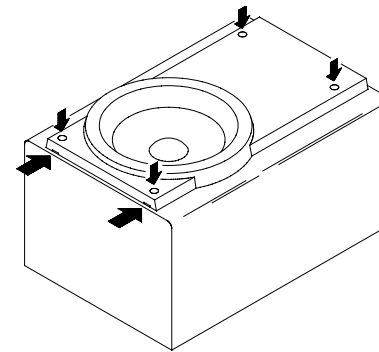

Type.3

Insert a flat-bladed screwdriver into the position indicated by the arrows and remove the panel. Turn the speaker unit to counter-clockwise direction while inserting a flat-bladed screwdriver into one of the hollows around speaker unit, and then remove the speaker unit. After replacing the speaker unit, install it turning to clockwise direction until "click" sound comes out.

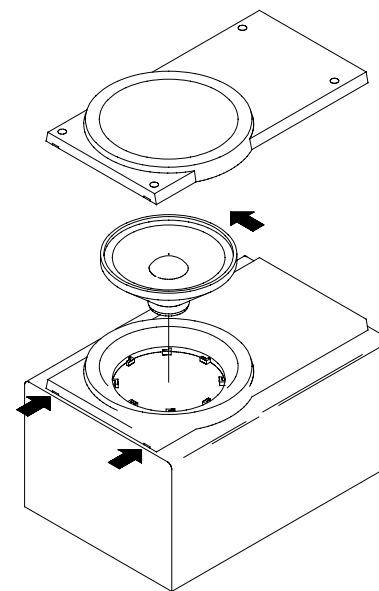

Type.4

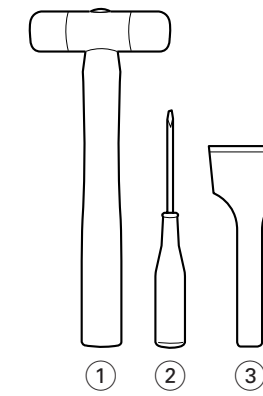

TOOLS

- ① Plastic head hammer
- ② (⊖) flat head screwdriver
- ③ Cut chisel

How to Remove the PANEL, FR

1. Insert the (⊖) flat head screwdriver tip into the gap between the PANEL, FR and the PANEL, SPKR. Tap the head of the (⊖) flat head screwdriver with the plastic hammer head, and create the clearance as shown in Fig-1.
2. Insert the cut chisel in the clearance, and tap the head of the cut chisel with plastic hammer as shown in Fig-2, to remove the PANEL, FR.
3. Place the speaker horizontally. Tap head of the cut chisel with plastic hammer as shown in Fig-3, and remove the PANEL, FR completely.

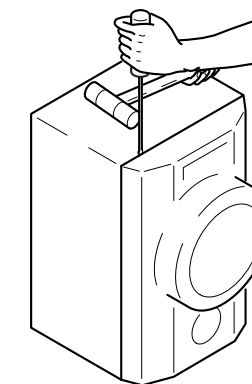

Fig-1

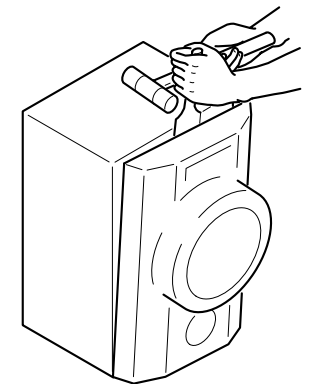

Fig-2

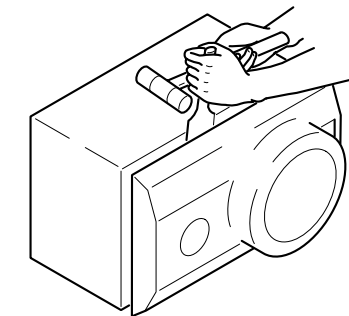

Fig-3

How to Attach the PANEL, FR

Attach the PANEL, FR to the PANEL, SPKR. Tap the four corners of the PANEL, FR with the plastic hammer to fit the PANEL, FR into the PANEL, SPKR completely.

SPEAKER PARTS LIST 1/1

DESCRIPTIONで判断できない物は "REFERENCE NAME LIST" を参照してください。
If can't understand for Description please kindly refer to "REFERENCE NAME LIST".

REF. NO	PART NO.	KANRI NO.	DESCRIPTION
1	8Z-CL5-543-010		CORD, SP
2	8Z-CL5-506-010		GRILLE, FRAME ASSY
3	8Z-CL5-503-010		PANEL, FR
4	8Z-CL5-505-010		PANEL, TW
5	8Z-CL5-542-010		SPKR, TW25
6	8Z-CL5-541-010		SPKR, W100



サービス技術ニュース	
番号	連絡内容
G- -	
G- -	
G- -	

アイワ株式会社 〒110-8710 東京都台東区池之端1-2-11 ☎03(3827)3111 (代表)
AIWA CO.,LTD. 2-11, IKENOHATA 1-CHOME, TAITO-KU, TOKYO 110-8710, JAPAN TEL:03 (3827) 3111