

SERVICE MANUAL

COMPACT DISC STEREO SYSTEM

- BASIC TAPE MECHANISM : TN-708C-128R
- BASIC CD MECHANISM : KSM-620AAA

SYSTEM	RECEIVER	CD/ CASSETTE	SPEAKER
XR-M88	RX-LM88	FD-LM88	SX-LM200

This Service Manual is the "Revision Publishing" and replaces "Simple Manual" (S/M Code No.09-996-333-3T3).

TABLE OF CONTENTS

SPECIFICATIONS.....	3
ACCESSORIES/PACKAGE LIST	3
PROTECTION OF EYES FROM LASER BEAM DURING SERVICING/ Precaution to replace Optical block	4
 MODEL NO. RX-LM88	
ELECTRICAL MAIN PARTS LIST	5, 6
TRANSISTOR ILLUSTRATION	7
FL (13-ST-36GNAK) GRID ASSIGNMENT/ANODE CONNECTION	8
WIRING-1 (POWER AMP)	9, 10
SCHEMATIC DIAGRAM-1 (POWER AMP)	11, 12
WIRING-2 (FRONT)	13, 14
SCHEMATIC DIAGRAM-2 (FRONT)	15, 16
WIRING-3 (TUNER)	17, 18
SCHEMATIC DIAGRAM-3 (TUNER)	19, 20
ELECTRICAL ADJUSTMENT	21
PRACTICAL SERVICE FIGURE	22
IC DESCRIPTION	23, 24
IC BLOCK DIAGRAM.....	25
MECHANICAL EXPLODED VIEW 1/1	26
MECHANICAL PARTS LIST 1/1	27
 MODEL NO. FD-LM88	
DISASSEMBLY INSTRUCTIONS	28-32
ELECTRICAL MAIN PARTS LIST	33-35
TRANSISTOR ILLUSTRATION	36
WIRING-1 (CD)	37-40
SCHEMATIC DIAGRAM-1 (CD 1/2)	41, 42
SCHEMATIC DIAGRAM-2 (CD 2/2)	43, 44
WIRING-2 (TAPE)	45, 46
WIRING-3 (KEY)	47, 48
WIRING-4 (FUNC)	49, 50
SCHEMATIC DIAGRAM-3 (TAPE/FUNC/KEY)	51, 52
TEST MODE	53
ELECTRICAL ADJUSTMENT	54, 55
PRACTICAL SERVICE FIGURE	56
IC DESCRIPTION	57-62
IC BLOCK DIAGRAM.....	63
MECHANICAL EXPLODED VIEW 1/1	64
MECHANICAL PARTS LIST 1/1	65
TAPE MECHANISM EXPLODED VIEW 1/1	66
TAPE MECHANISM PARTS LIST 1/1	67
CD MECHANISM EXPLODED VIEW 1/1	68
CD MECHANISM PARTS LIST 1/1	69
 MODEL NO. SX-LM200	
SPEAKER DISASSEMBLY INSTRUCTIONS	70
SPEAKER PARTS LIST 1/1	71

SPECIFICATIONS

STEREO RECEIVER RX-LM88

FM tuner section

Tuning range	87.5 MHz to 108 MHz
Usable sensitivity (IHF)	13.2 dBf
Antenna terminals	75 ohms (unbalanced)

AM tuner section

Tuning range	531 kHz to 1602 kHz (9 kHz step) 530 kHz to 1710 kHz (10 kHz step)
Usable sensitivity	350 μ V/m
Antenna	Loop antenna

Amplifier section

Power output	Rated 16 W + 16 W (6 ohms, T.H.D. 1%, 1kHz) Reference 20 W + 20 W (6 ohms, T.H.D 10%, 1 kHz)
Total harmonic distortion	0.1% (7W, 1 kHz, 6 ohms, DIN AUDIO)
Outputs	SUPER WOOFER: 1.4 V SPEAKERS: accept speakers of 6 ohms or more PHONES (stereo minijack): accepts headphones of 16 ohms or more

General

Power requirements	120 V/220-240 V AC, switchable 50/60 Hz
Power consumption	57 W
Standby power consumption	2.5 W (power economizing mode set to ON)
Dimensions (W x H x D)	144 x 100 x 206.5 mm
Weight	2.7 kg

STEREO CASSETTE DECK/COMPACTDISC PLAYER FD-LM88

Compact disc player section

Laser	Semiconductor laser ($\lambda = 780$ nm)
D-A converter	1 bit dual
Signal-to-noise ratio	85 dB (1 kHz, 0 dB)
Harmonic distortion	0.05 % (1 kHz, 0 dB)
Wow and flutter	Unmeasurable

Cassette deck section

Track format	4 tracks, 2 channels stereo
Frequency response	CrO ₂ tape: 50 Hz – 16000 Hz Normal tape: 50 Hz – 15000 Hz
Signal-to-noise ratio	54 dB (CrO ₂ tape peak level)
Recording system	AC bias
Heads	Recording/playback head x1 Erase head x2

General

Inputs	MD IN: 400 mV AUX IN: 470 mV
Outputs	DIGITAL OUT LINE OUT: 400 mV
Dimensions (W x H x D)	144 x 100.6 x 203 mm
Weight	1.5 kg

SPEAKER SYSTEM SX-LM200

Cabinet type	2 way, bass reflex (magnetic shielded type)
Speakers	Woofer: 100 mm cone type Tweeter: 25 mm balanced dome type
Impedance	6 ohms
Output sound pressure level	87 dB/W/m
Dimensions (W x H x D)	120 x 200 x 182 mm
Weight	1.6 kg

- Design and specifications are subject to change without notice.
- Dolby noise reduction manufactured under license from Dolby Laboratories Licensing Corporation. "DOLBY" and the double-D symbol  are trademarks of Dolby Laboratories Licensing Corporation.
- The word "BBE" and the "BBE symbol" are trademarks of BBE Sound, Inc. Under license from BBE Sound, Inc.

ACCESSORIES/PACKAGE LIST

DESCRIPTIONで判断できない物は "REFERENCE NAME LIST" を参照してください。
If can't understand for Description please kindly refer to "REFERENCE NAME LIST".

REF. NO	PART NO.	KANRI NO.	DESCRIPTION
1	8Z-CLB-911-010		IB,H(EC-K)M
2	87-043-115-010		ANT,FEEDER FM
3	87-A90-030-010		ANT,LOOP AM-NC C
4	8Z-CLB-955-010		RC UNIT,ZCL-11
	5	87-A90-786-010	PLUG,CONVERSION IR46

PROTECTION OF EYES FROM LASER BEAM DURING SERVICING

This set employs laser. Therefore, be sure to follow carefully the instructions below when servicing.

WARNING!

WHEN SERVICING, DO NOT APPROACH THE LASER EXIT WITH THE EYE TOO CLOSELY. IN CASE IT IS NECESSARY TO CONFIRM LASER BEAM EMISSION. BE SURE TO OBSERVE FROM A DISTANCE OF MORE THAN 30cm FROM THE SURFACE OF THE OBJECTIVE LENS ON THE OPTICAL PICK-UP BLOCK.

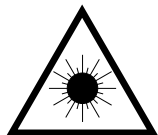

- Caution: Invisible laser radiation when open and interlocks defeated avoid exposure to beam.
- Advarsel: Usynlig laserstråling ved åbning, når sikkerhedsafbrydere er ude af funktion. Undgå udsættelse for stråling.

VAROITUS!

Laiteen Käyttäminen muulla kuin tässä käyttöohjeessa mainitulla tavalla saattaa altistaa käyttäjän turvallisuusluokan 1 ylitävälle näkymättömälle lasersäteilylle.

WARNING!

Om apparaten används på annat sätt än vad som specificeras i denna bruksanvisning, kan användaren utsättas för osynlig laserstråling, som överskrider gränsen för laserklass 1.

Precaution to replace Optical block (KSM-620AAA)

Body or clothes electrostatic potential could ruin laser diode in the optical block. Be sure ground body and workbench, and use care the clothes do not touch the diode.

- 1) After the connection, remove solder shown in the right figure.

CAUTION

Use of controls or adjustments or performance of procedures other than those specified herein may result in hazardous radiation exposure.

ATTENTION

L'utilisation de commandes, réglages ou procédures autres que ceux spécifiés peut entraîner une dangereuse exposition aux radiations.

ADVARSEL!

Usynlig laserstråling ved åbning, når sikkerhedsafbrydere er ude af funktion. Undgå udsættelse for stråling.

This Compact Disc player is classified as a CLASS 1 LASER product.

The CLASS 1 LASER PRODUCT label is located on the rear exterior.

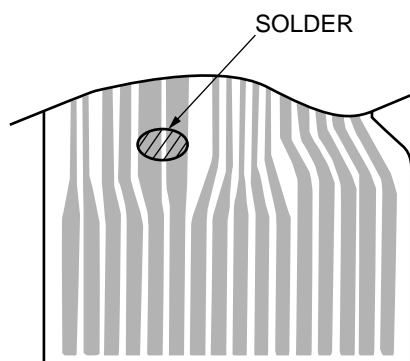
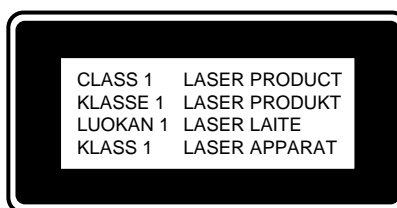

MODEL NO. RX-LM88

ELECTRICAL MAIN PARTS LIST

DESCRIPTIONで判断できない物は "REFERENCE NAME LIST" を参照してください。
 If can't understand for Description please kindly refer to "REFERENCE NAME LIST".

REF. NO	PART NO.	KANRI NO.	DESCRIPTION	REF. NO	PART NO.	KANRI NO.	DESCRIPTION
IC				C185	87-010-322-080		C-CAP,S 100P-50 J CH
	87-070-127-110	IC,LC72131 D		C186	87-010-322-080		C-CAP,S 100P-50 J CH
	87-A20-913-010	IC,LA1837NL		C187	87-010-322-080		C-CAP,S 100P-50 J CH
	8Z-CL1-627-010	IC,LC866532A-5L31RX		C191	87-A10-479-080		CAP,CER 2200P-250 M E KH
				C195	87-010-405-010		CAP, ELECT 10-50V
TRANSISTOR				C281	87-010-401-080		CAP, ELECT 1-50V
	89-213-702-010	TR,2SB1370 (1.8W)		C282	87-010-263-080		CAP, ELECT 100-10V
	87-026-610-080	TR,KTC3198GR		C283	87-010-380-080		CAP, ELECT 47-16V
	87-A30-076-080	C-TR,2SC3052F		C284	87-010-260-080		CAP, ELECT 47-25V
	87-A30-075-080	C-TR,2SA1235F		CN101	87-A60-813-010		CONN,8P H BLK TAC-L8X
	87-A30-234-080	TR,CSC4115BC		CN102	87-A60-813-010		CONN,8P H BLK TAC-L8X
	87-026-609-080	TR,KTA1266GR		CN104	87-A60-770-010		CONN,18P B TMC-D(X)
	87-A30-073-080	C-TR,RT1N 141C		CN203	87-A60-109-010		CONN,2P V S2M-2W
	87-A30-190-080	TR,CC5551		CN301	87-A60-778-010		CONN,18P B TMC-D(P)
	87-A30-307-010	TR,2SD2619		CN302	87-A60-058-010		CONN,10P V 9604S-10C
	87-A30-306-010	TR,2SB1677		CN305	8Z-CL1-665-010		CONN ASSY,5P FR
	87-A30-119-040	C-TR,2SC3906K R		J201	87-A60-420-010		JACK,3.5 ST (MSC)
	87-A30-047-080	TR,CSD655E		J202	87-099-801-010		JACK,PIN 1P BLK
	87-A30-107-070	C-TR,CMBT5401		J501	87-A60-782-010		CONN,19P H FG
	87-A30-074-080	C-TR,RT1P 141C		W101	8Z-CL1-656-010		F-CABLE,7P 2.5 150MM PWR
	87-A30-071-080	C-TR,RT1N 144C		W102	8Z-CL1-654-010		F-CABLE,2P 2.5 170MM SUBPT
	87-A30-087-080	C-FET,2SK2158		W103	8Z-CL1-655-010		F-CABLE,4P 2.5 100MM PWR
	87-A30-072-080	C-TR,RT1P 144C		WH102	87-A90-460-010		HLDR,WIRE 2.5-7P
	89-327-143-080	TR,2SC2714 (0.1W)		FRONT C.B			
	89-505-434-540	C-FET,2SK543(4/5)		C301	87-012-145-080		CAP, CHIP S 270P CH
	87-A30-086-070	C-TR,CSD1306E		C303	87-010-312-080		C-CAP,S 15P-50 CH
DIODE				C304	87-015-785-080		CHIP CAPACITOR, 0.1FZ-25Z
	87-070-345-080	DIODE,IN4148		C305	87-010-196-080		CHIP CAPACITOR,0.1-25
	87-070-178-090	DIODE,1N5402-BD54		C341	87-010-493-080		CAP,E 0.47-50 GAS
	87-070-274-080	DIODE,1N4003 SEM		C342	87-A10-189-040		CAP,E 220-10
	87-A40-345-080	ZENER,MTZJ10C		C343	87-010-196-080		CHIP CAPACITOR,0.1-25
	87-A40-269-080	C-DIODE,MC2836		C347	87-010-405-080		CAP, ELECT 10-50V
	87-A40-270-080	C-DIODE,MC2838		C351	87-010-194-080		CAP, CHIP 0.047
	87-A40-004-080	ZENER,MTZJ16A		C352	87-010-194-080		CAP, CHIP 0.047
	87-A40-312-080	ZENER,DZ33M		C358	87-010-263-080		CAP, ELECT 100-10V
	87-A40-313-080	C-DIODE,MC 2840		C371	87-010-404-080		CAP, ELECT 4.7-50V
	87-A40-488-080	DIODE,1SS244		C372	87-010-404-080		CAP, ELECT 4.7-50V
	87-A40-509-080	ZENER,MTZJ6.8C		C373	87-010-408-080		CAP, ELECT 47-50V
	87-017-149-080	ZENER,HZS6A2L		FL301	8Z-CL1-630-010		FL,13-ST-36GNAK
	87-020-465-080	DIODE,1SS133 (110MA)		HL301	8Z-CL1-204-010		HLDR,FL
POWER C.B				L301	87-A50-052-010		COIL,CLOCK 5.76MHZ T1
C101	87-010-387-080	CAP,E 470-25 SME		LED361	87-A40-568-010		LED,L-13HD RED
C102	87-016-051-090	CAP,E 2200-35 SMG		POWER AMP C.B			
C103	87-016-051-090	CAP,E 2200-35 SMG		C201	87-010-260-080		CAP, ELECT 47-25V
C106	87-010-196-080	CHIP CAPACITOR,0.1-25		C202	87-010-260-080		CAP, ELECT 47-25V
C107	87-010-196-080	CHIP CAPACITOR,0.1-25		C203	87-A10-946-080		C-CAP,S 220P-100 J CH
C108	87-010-196-080	CHIP CAPACITOR,0.1-25		C204	87-A10-946-080		C-CAP,S 220P-100 J CH
C109	87-010-196-080	CHIP CAPACITOR,0.1-25		C209	87-010-186-080		CAP,CHIP 4700P
C110	87-010-928-090	CAP,E 4700-25 SMG		C210	87-010-186-080		CAP,CHIP 4700P
C111	87-012-140-080	CAP 470P		C211	87-012-368-080		C-CAP,S 0.1-50 F
C113	87-010-384-080	CAP, ELECT 100-25V		C212	87-012-368-080		C-CAP,S 0.1-50 F
C114	87-010-060-080	CAP, ELECT 100-16V		C213	87-010-195-080		C-CAP,S 0.068-25 F
C115	87-010-235-080	CAP,E 470-16 SME		C214	87-010-195-080		C-CAP,S 0.068-25 F
C132	87-010-260-080	CAP, ELECT 47-25V		C215	87-010-544-080		CAP, ELECT 0.1-50V
C133	87-010-403-080	CAP, ELECT 3.3-50V		C216	87-010-544-080		CAP, ELECT 0.1-50V
C151	87-010-196-080	CHIP CAPACITOR,0.1-25		C217	87-010-182-080		C-CAP,S 2200P-50 B
C171	87-010-260-080	CAP, ELECT 47-25V		C218	87-010-182-080		C-CAP,S 2200P-50 B
C172	87-010-260-080	CAP, ELECT 47-25V		C221	87-010-186-080		CAP,CHIP 4700P
C173	87-010-260-080	CAP, ELECT 47-25V		C222	87-010-186-080		CAP,CHIP 4700P
C174	87-010-260-080	CAP, ELECT 47-25V		C223	87-010-403-080		CAP, ELECT 3.3-50V
C175	87-010-247-080	CAP, ELECT 100-50V		C224	87-010-403-080		CAP, ELECT 3.3-50V
C176	87-010-263-080	CAP, ELECT 100-10V		C263	88-266-610-810		CAP,SC 1000P-25 K SR DD400
C182	87-010-322-080	C-CAP,S 100P-50 J CH		C264	88-266-610-810		CAP,SC 1000P-25 K SR DD400
C183	87-010-322-080	C-CAP,S 100P-50 J CH		C265	87-010-546-080		CAP, ELECT 0.33-50V
C184	87-010-322-080	C-CAP,S 100P-50 J CH		C266	87-010-546-080		CAP, ELECT 0.33-50V
				C271	87-015-819-080		CAPACITOR,0.01

REF. NO	PART NO.	KANRI NO.	DESCRIPTION	REF. NO	PART NO.	KANRI NO.	DESCRIPTION
C277	87-010-197-080		CAP, CHIP 0.01 DM	C757	87-012-188-080		C-CAP,U 47P-50 CH
CN201	87-A60-812-010		CONN,8P V BLK TAC-L8P	C758	87-012-167-080		C-CAP,U 5P-50 CH
CN202	87-A60-812-010		CONN,8P V BLK TAC-L8P	C763	87-010-829-080		CAP, U 0.047-16
J203	87-YP6-608-010		TERMINAL,SPKR 4P	C764	87-012-337-080		C-CAP,U 56P-50 CH
L201	87-003-383-010		COIL,1UH-S	C765	87-012-286-080		CAP, U 0.01-25
L202	87-003-383-010		COIL,1UH-S	C768	87-012-286-080		CAP, U 0.01-25
R215	87-A00-258-080		RES,M/F 0.22-1W J	C769	87-010-260-080		CAP, ELECT 47-25V
R216	87-A00-258-080		RES,M/F 0.22-1W J	C770	87-010-829-080		CAP, U 0.047-16
R217	87-A00-258-080		RES,M/F 0.22-1W J	C771	87-010-383-080		CAP, ELECT 33-25V
R218	87-A00-258-080		RES,M/F 0.22-1W J	C772	87-010-829-080		CAP, U 0.047-16
R219	87-A00-258-080		RES,M/F 0.22-1W J	C773	87-010-196-080		CHIP CAPACITOR,0.1-25
R220	87-A00-258-080		RES,M/F 0.22-1W J	C774	87-010-263-080		CAP, ELECT 100-10V
TH201	87-A91-042-080		C-THMS,100K 55001	C775	87-010-404-080		CAP, ELECT 4.7-50V
TH202	87-A91-042-080		C-THMS,100K 55001	C776	87-012-286-080		CAP, U 0.01-25
				C777	87-010-400-080		CAP, ELECT 0.47-50V
MAIN PT C.B				C778	87-010-401-080		CAP, ELECT 1-50V
△C191	87-A10-479-080		CAP,CER 2200P-250 M E KH	C779	87-010-401-080		CAP, ELECT 1-50V
CNA107	8Z-CL1-657-010		CONN ASSY,7P 160MM PTPRI	C780	87-010-196-080		CHIP CAPACITOR,0.1-25
△PR151	87-A90-094-080		PROTECTOR,4A 491SERIES 60V	C781	87-010-405-080		CAP, ELECT 10-50V
△PT101	8Z-CL1-623-010		PT,E	C782	87-010-405-080		CAP, ELECT 10-50V
△RY101	87-A91-281-010		RELAY,AC12V OSA-SS-202DM5	C783	87-012-286-080		CAP, U 0.01-25
△T101	87-A60-317-010		TERMINAL, 1P MSC	C784	87-012-286-080		CAP, U 0.01-25
△T102	87-A60-317-010		TERMINAL, 1P MSC	C785	87-010-401-080		CAP, ELECT 1-50V
WH101	87-A90-460-010		HLD, WIRE 2.5-7P	C789	87-012-275-080		C-CAP,U 1200P-50 B
				C790	87-012-275-080		C-CAP,U 1200P-50 B
SUB PT C.B				C791	87-010-405-080		CAP, ELECT 10-50V
CNA108	8Z-CL1-657-010		CONN ASSY,7P 160MM PTPRI	C793	87-012-273-080		C-CAP,U 820P-50 B
△PT102	8Z-CL1-674-010		PT,SUB ZCL-1(H)	C794	87-010-406-080		CAP, ELECT 22-50
△SW101	87-A90-234-010		SW,SL 1-2-2 SWS2201	C795	87-010-596-080		CAP, S 0.047-16
				C796	87-010-403-080		CAP, ELECT 3.3-50V
TU INF C.B				C799	87-010-829-080		CAP, U 0.047-16
CN114	87-099-570-010		CONN,13P TUC-P13P-B1	C812	87-012-286-080		CAP, U 0.01-25
CN115	87-A60-114-010		CONN,4P H S2M-4WR	C820	87-010-260-080		CAP, ELECT 47-25V
CN116	87-A60-077-010		CONN,10P H 9604S-10F	C821	87-012-286-080		CAP, U 0.01-25
				C822	87-012-286-080		CAP, U 0.01-25
TUNER C.B				C823	87-012-286-080		CAP, U 0.01-25
C701	87-010-381-080		CAP, ELECT 330-16V	C828	87-010-196-080		CHIP CAPACITOR,0.1-25
C702	87-010-404-080		CAP, ELECT 4.7-50V	C829	87-010-196-080		CHIP CAPACITOR,0.1-25
C703	87-012-286-080		CAP, U 0.01-25	C959	87-010-196-080		CHIP CAPACITOR,0.1-25
C704	87-012-286-080		CAP, U 0.01-25	C960	87-010-196-080		CHIP CAPACITOR,0.1-25
C705	87-A10-592-080		C-CAP,S 0.015-50 J B	C961	87-012-174-080		CAP CHIP CERA SS 12P CHJ
C706	87-A10-592-080		C-CAP,S 0.015-50 J B	C963	87-010-196-080		CHIP CAPACITOR,0.1-25
C709	87-012-195-080		C-CAP,U 100P-50CH	CF801	87-008-261-010		FILTER, SFE10.7MA5-A
C711	87-010-260-080		CAP, ELECT 47-25V	CF802	87-008-261-010		FILTER, SFE10.7MA5-A
C712	87-010-831-080		C-CAP,U,0.1-16F	CN701	87-A60-700-010		CONN,13P H GRY TUC-P13X-C1
C714	87-012-286-080		CAP, U 0.01-25	FFE801	A8-8ZA-190-030		8ZA-1 FEUNM
C717	87-012-286-080		CAP, U 0.01-25	L771	87-A50-266-010		COIL,FM DET-2N(TOK)
C719	87-012-286-080		CAP, U 0.01-25	L772	87-A91-110-010		FLTR,PCFJZH-450 (TOK)
C720	87-012-195-080		C-CAP,U 100P-50CH	L981	8Z-ZA1-664-010		COIL,AM PACK 4(TOK)
C721	87-012-176-080		CAP 15P	X721	87-A70-061-010		VIB,XTAL 4.500MHZ CSA-309
C722	87-012-176-080		CAP 15P				
C723	87-012-274-080		CHIP CAP,U 1000P-50B				
C725	87-012-274-080		CHIP CAP,U 1000P-50B				
C727	87-010-196-080		CHIP CAPACITOR,0.1-25				
C728	87-010-248-080		CAP, ELECT 220-10V				
C729	87-012-274-080		CHIP CAP,U 1000P-50B				
C731	87-012-286-080		CAP, U 0.01-25				
C733	87-010-987-080		C-CAP,S 1500P-50 CH				
C734	87-010-987-080		C-CAP,S 1500P-50 CH				
C735	87-010-987-080		C-CAP,S 1500P-50 CH				
C736	87-010-987-080		C-CAP,S 1500P-50 CH				
C737	87-A10-592-080		C-CAP,S 0.015-50 J B				
C738	87-A10-592-080		C-CAP,S 0.015-50 J B				
C751	87-010-220-080		C-CAP,S 0.018-25 B				
C752	87-010-220-080		C-CAP,S 0.018-25 B				
C756	87-012-286-080		CAP, U 0.01-25				

- Regarding connectors, they are not stocked as they are not the initial order items.
The connectors are available after they are supplied from connector manufacturers upon the order is received.

○チップ抵抗部品コード/CHIP RESISTOR PART CODE

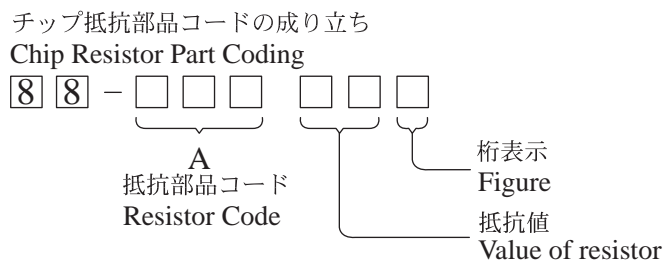

チップ抵抗
Chip resistor

容量 Wattage	種類 Type	許容誤差 Tolerance	記号 Symbol	寸法/Dimensions (mm)			抵抗コード : A Resistor Code : A	
				外形/Form	L	W		t
1/16W	1005	± 5%	CJ		1.0	0.5	0.35	104
1/16W	1608	± 5%	CJ		1.6	0.8	0.45	108
1/10W	2125	± 5%	CJ		2	1.25	0.45	118
1/8W	3216	± 5%	CJ		3.2	1.6	0.55	128

TRANSISTOR ILLUSTRATION

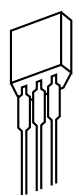

ECB

CSC4115



ECB

CC5551
CSD655
KTA1266
KTC3198

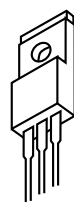

BCE

2SB1370
2SB1677
2SD2619

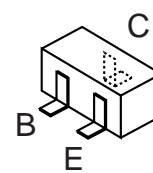

2SA1235
2SC2714
2SC3052
2SC3906
CMBT5401

CSD1306
RT1N141C
RT1N144C
RT1P141C
RT1P144C

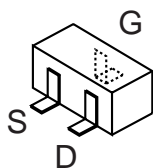

2SK543

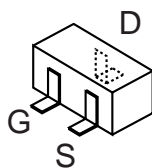

2SK2158

FL (13-ST-36GNAK) GRID ASSIGNMENT/ANODE CONNECTION

GRID ASSIGNMENT

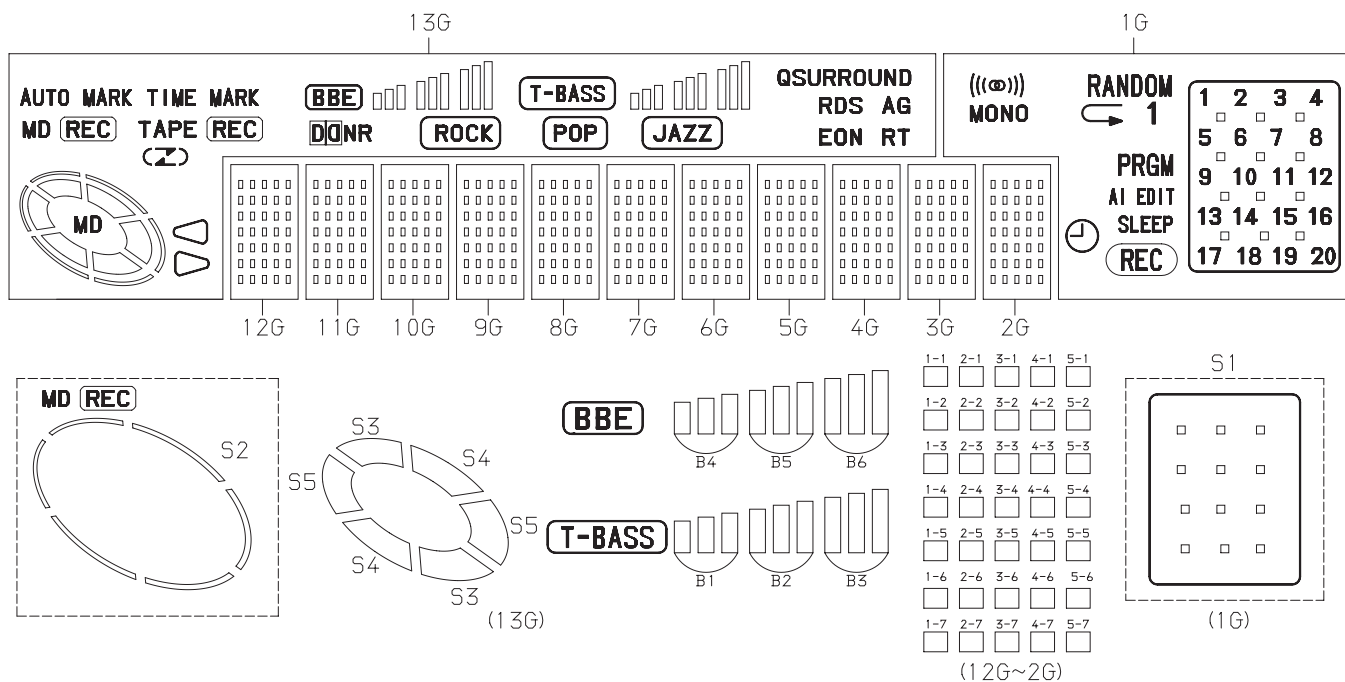

ANODE CONNECTION

	13G	12G~2G	1G		13G	12G~2G	1G
P1	JAZZ	1-1	1	P19)	4-4	8
P2	POP	2-1	↶	P20	⚡	5-4	9
P3	ROCK	3-1	MONO	P21	⌒	1-5	10
P4	DQ NR	4-1	RANDOM	P22	TAPE REC	2-5	11
P5	RT	5-1	((∞))	P23	S2	3-5	12
P6	EON	1-2	PRGM	P24	S3	4-5	13
P7	AG	2-2	AI	P25	S4	5-5	14
P8	RDS	3-2	EDIT	P26	S5	1-6	15
P9	B1	4-2	SLEEP	P27	MD	2-6	16
P10	B2	5-2	⌚	P28	TIME MARK	3-6	17
P11	B3	1-3	REC	P29	AUTO MARK	4-6	18
P12	T-BASS	2-3	(CALENDAR) 1	P30	QSURROUND	5-6	19
P13	B4	3-3	2	P31	-	1-7	20
P14	B5	4-3	3	P32	-	2-7	S1
P15	B6	5-3	4	P33	-	3-7	-
P16	BBE	1-4	5	P34	-	4-7	-
P17	▷	2-4	6	P35	-	5-7	-
P18	▷	3-4	7				

WIRING-1 (POWER AMP)

1 2 3 4 5 6 7 8 9 10 11 12 13 14

A
B
C
D
E
F
G
H
I
J
K

TO/FROM TU INF C.B
CN115

POWER C. B

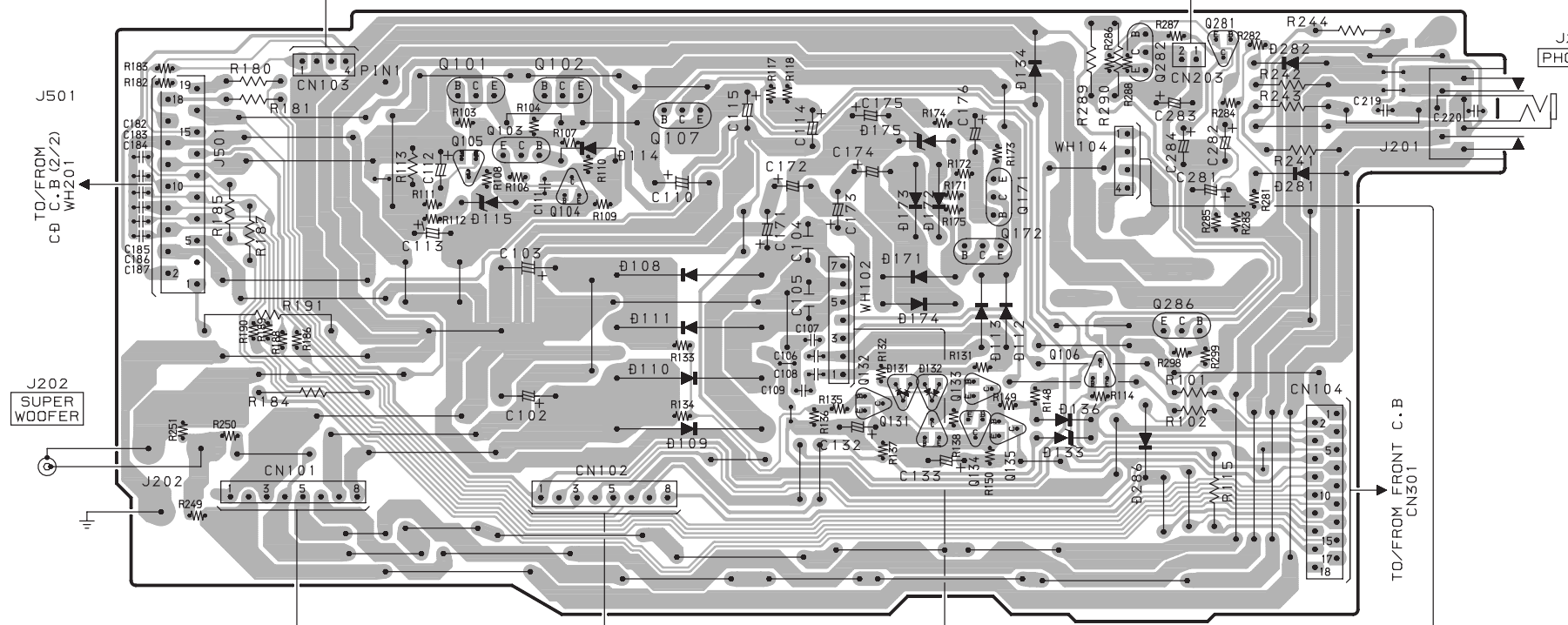

SUB PT C. B

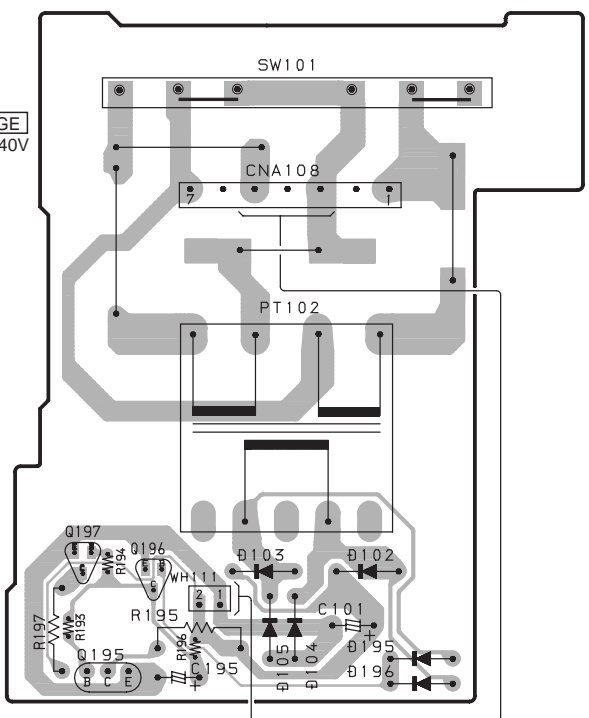

POWER AMP C. B

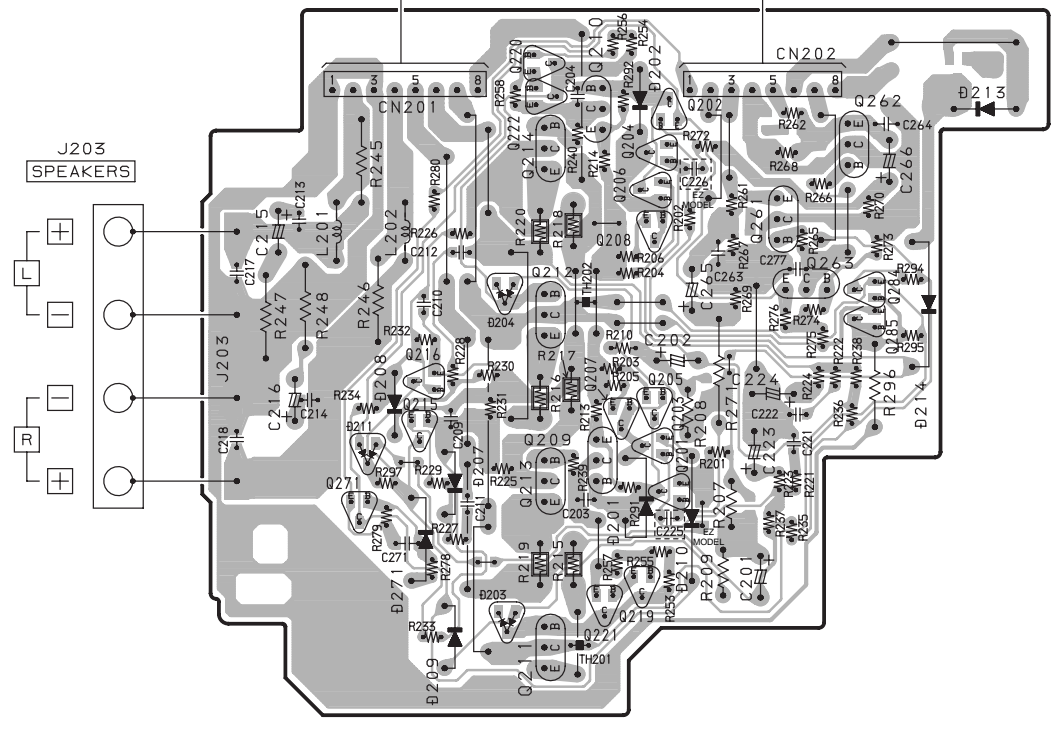

MAIN PT C. B

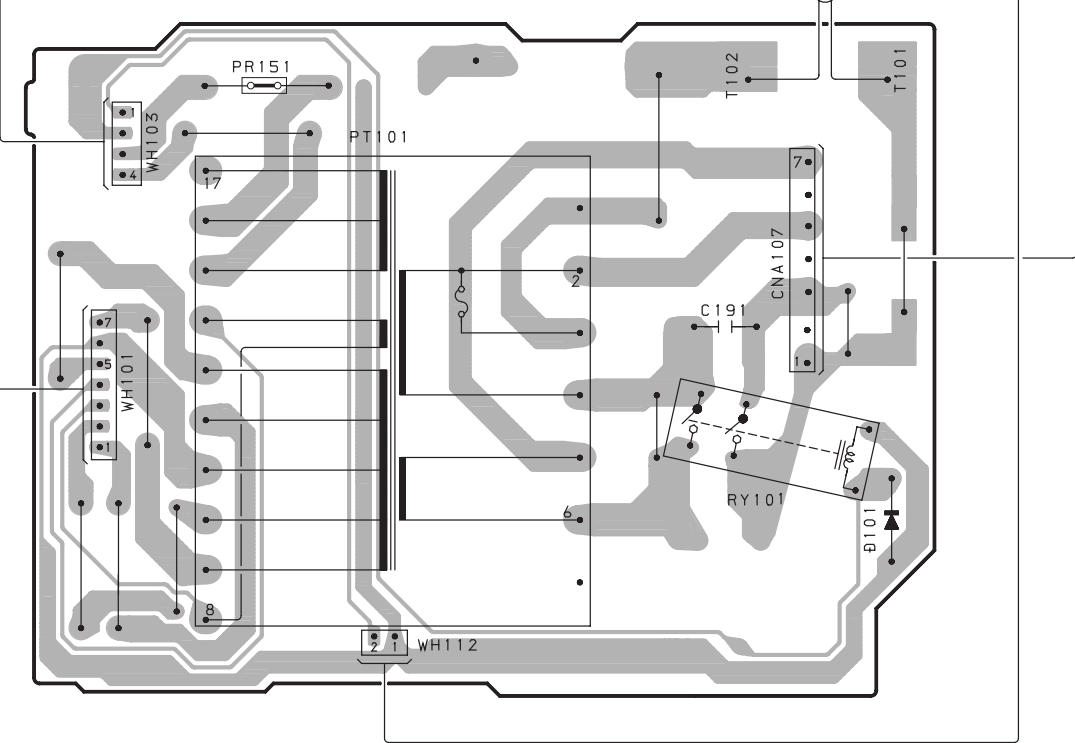

FRONT C.B

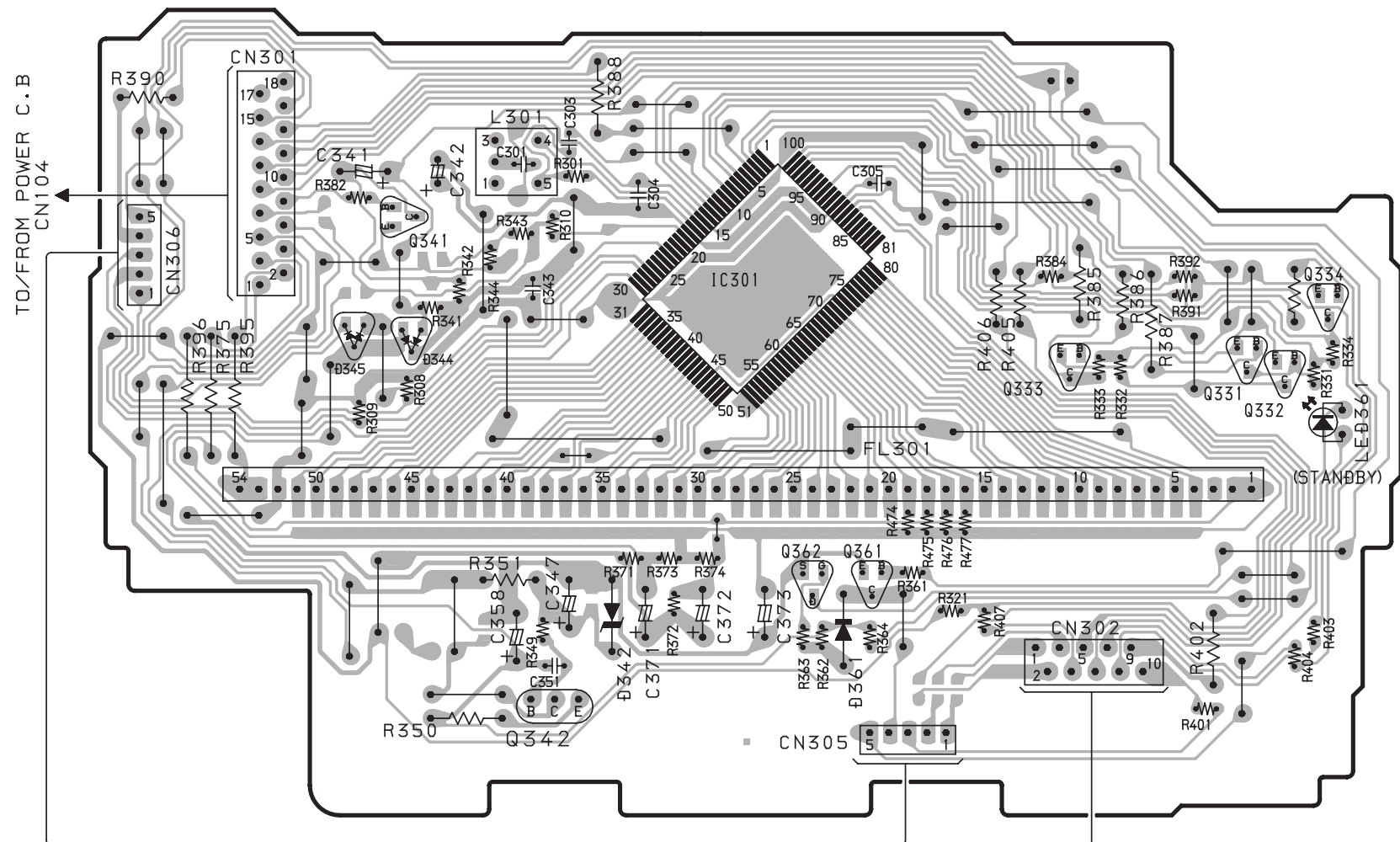

TU INF C.B

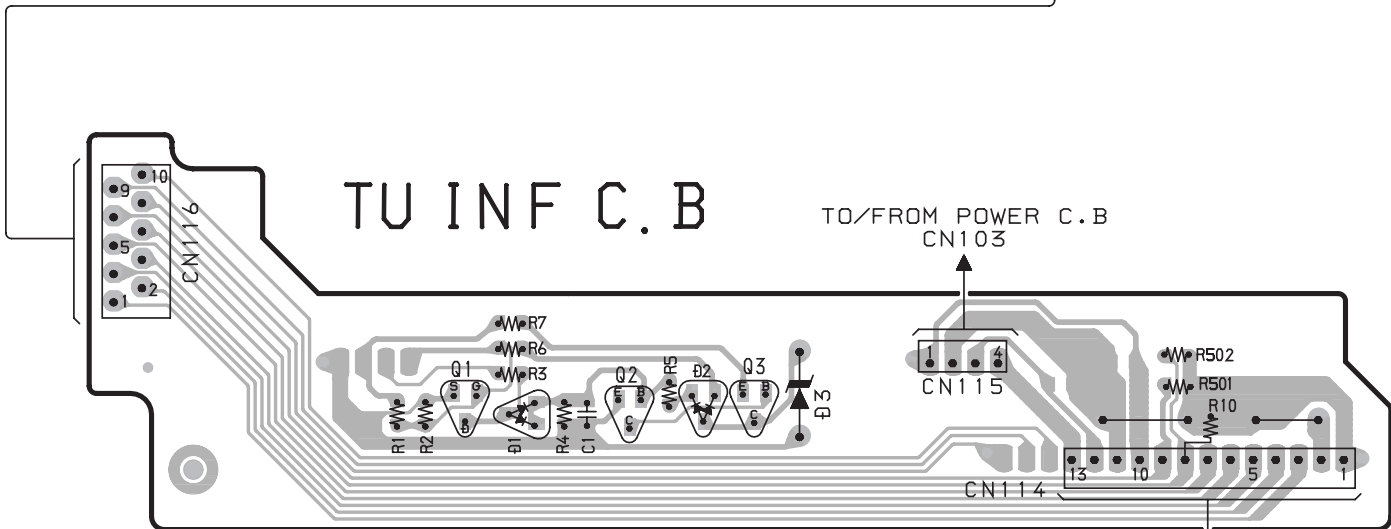

SCHEMATIC DIAGRAM-2 (FRONT)

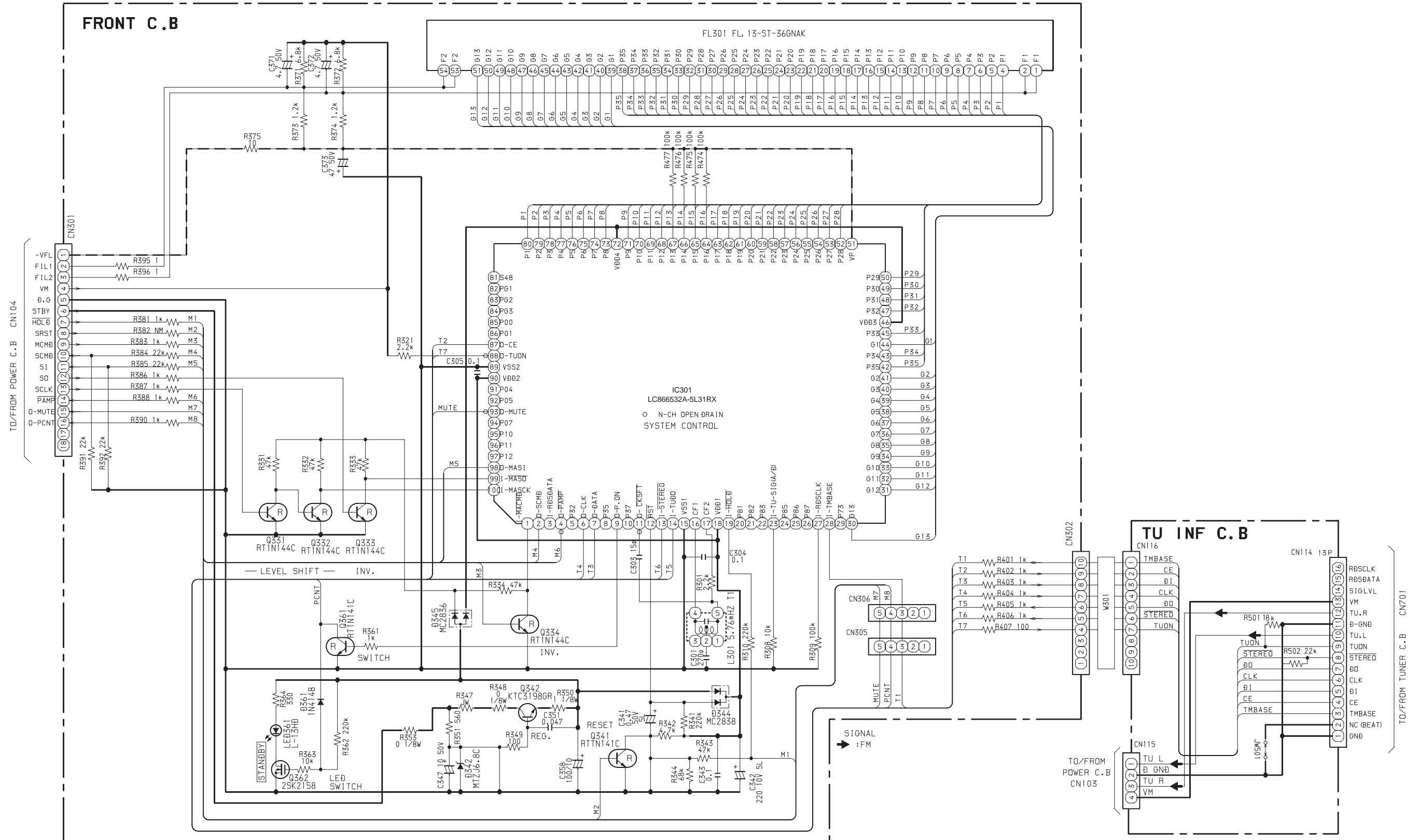

TUNER C. B

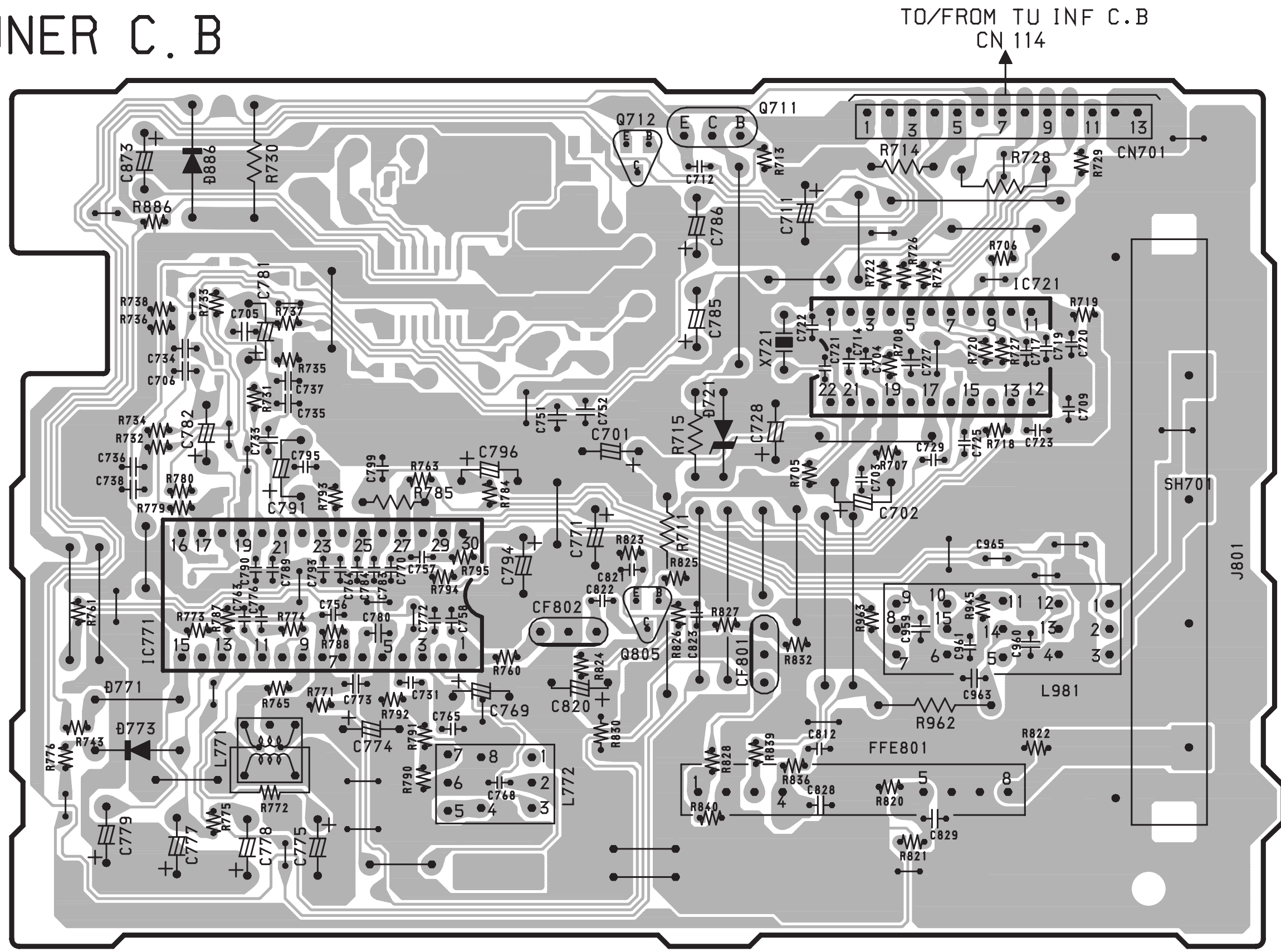

TO/FROM TU INF C.B
CN 114

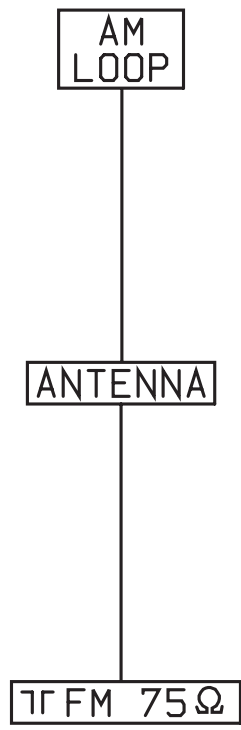

SCHEMATIC DIAGRAM-3 (TUNER)

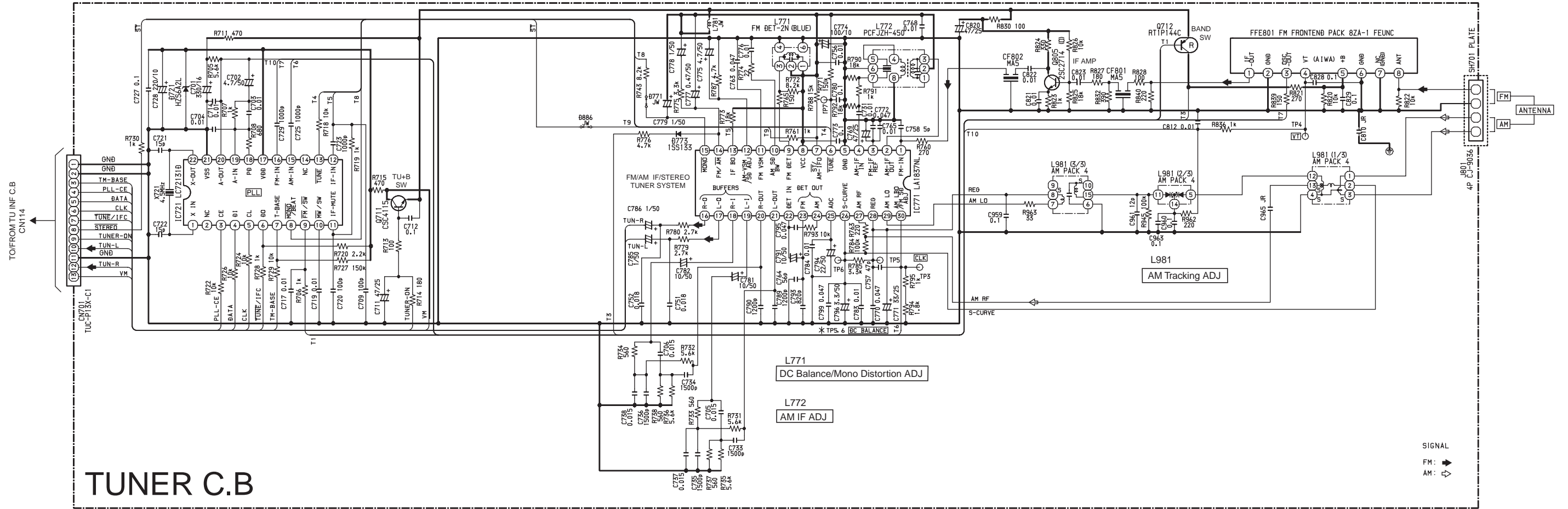

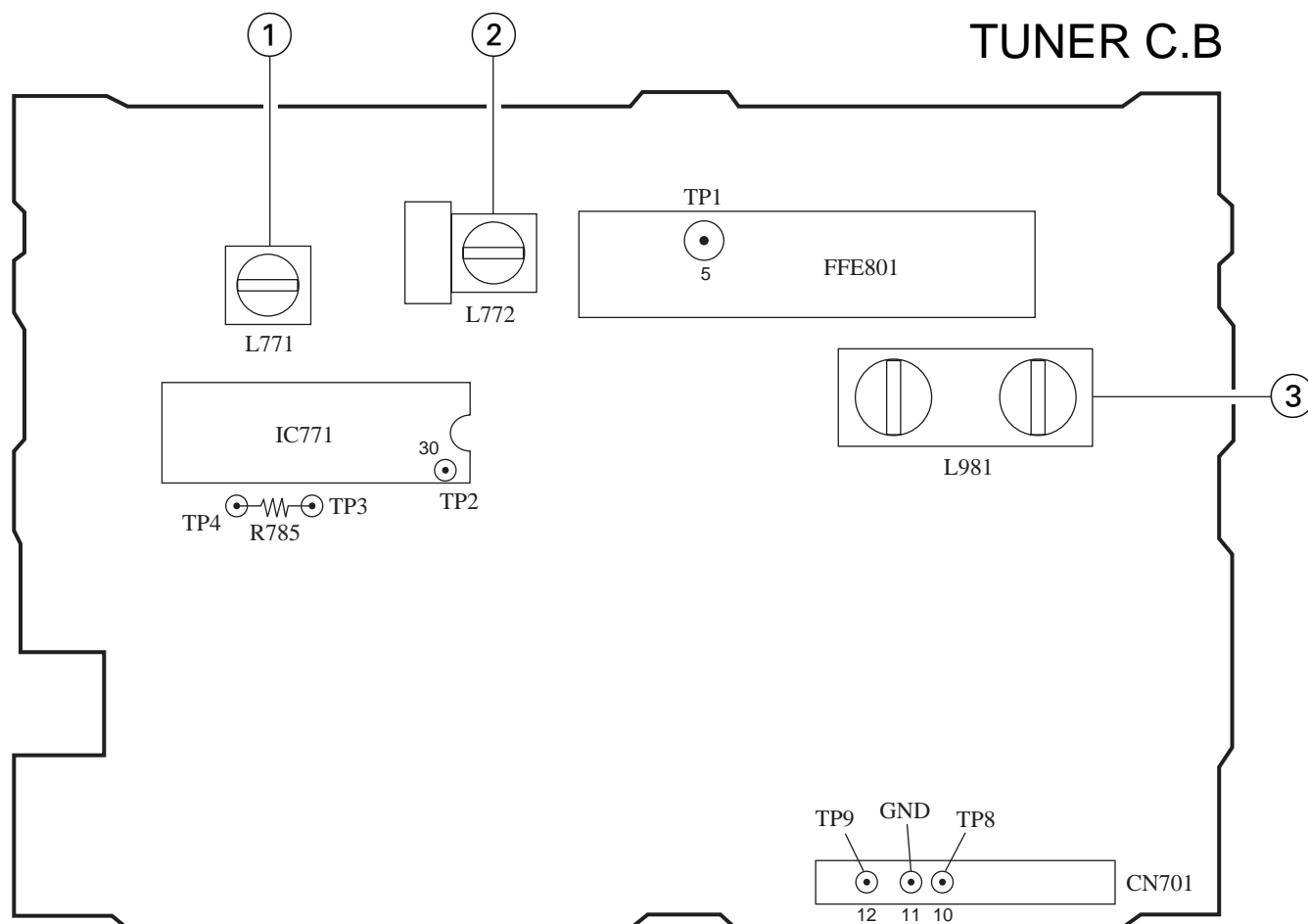

< TUNER SECTION >

1. DC Balance/Mono Distortion Adjustment
 - Settings:
 - Test point: TP3, TP4
 - Adjustment location: L771
 - Input level: 60dB μ V
 - Method: Set to FM 98.0MHz and adjust L771 so that the voltage between TP3 and TP4 becomes $0V \pm 0.04V$.
Next, check that the distortion is less than 1.3%.
2. AM IF Adjustment
 - Settings:
 - Test point: TP8, TP9
 - L772 455kHz
3. AM Tracking Adjustment
 - Settings:
 - Test point: TP8, TP9
 - Adjustment location: L981
 - Method: Set to AM 603kHz and adjust L981 so that the test point becomes maximum.
4. AM VT Check
 - Settings:
 - Test point: TP1 (VT)
 - Method: Set to AM 1602kHz and check that the test point is less than 8.0V.
Then set to AM 531kHz and check that the test point is more than 0.6V.
5. Clock Frequency Check
 - Settings:
 - Test point: TP2 (CLK IC771 pin30)
 - Method: Set to AM 1602kHz and check that the test point becomes $2052kHz \pm 45Hz$.
6. FM VT Check
 - Settings:
 - Test point: TP1 (VT)
 - Method: Set to FM 87.5MHz, 108.0MHz and check that the test point is more than 0.5V (87.5MHz) and less than 8.0V (108.0MHz).

PRACTICAL SERVICE FIGURE

< TUNER SECTION >

<FM SECTION>

IHF Sensitivity: (THD 3%)	4dB±6dB (at 87.5/98.0MHz) 5dB±6dB (at 108MHz)
Signal to noise ratio:	More than 65dB (at 98.0MHz)
Distortion: (Input: 66dB)	Less than 1.3% (at 98.0MHz)
Stereo separation:	More than 30dB (at 98.0MHz)
Intermediate frequency:	10.7MHz

<AM SECTION>

Sensitivity: (S/N 20dB)	54dB±6dB (at 603kHz) 52dB±6dB (at 999/1404kHz)
Signal to noise ratio: (Input: 100dB)	More than 34dB (at 999kHz)
Distortion:	Less than 1.5% (at 999kHz)
Intermediate frequency:	450kHz

IC DESCRIPTION

IC, LC866532A-5L31RX

Pin No.	Pin Name	I/O	Description
1	I-MACMD	I	Command input from master microprocessor.
2	O-SCMD	O	Serial data output to master microprocessor.
3	I-RDSDATA	I	RDS data input.
4	O-PAMP	O	Power supply control output (power supply ON/OFF of POWER AMP).
5	P32	—	NC.
6	O-CLK	O	Connected to TUNER PLL IC LC72131 pin-⑤ CL.
7	O-DATA	O	Connected to TUNER PLL IC LC72131 pin-④ DI.
8	P35	—	NC.
9	O-P.ON	O	Power save mode control output
10	P37	—	NC.
11	O-CKSFT	O	Clock shift output. "L" at clock shift.
12	RST	I	Microprocessor reset.
13	I-STEREO	I	TUNER, STEREO detection.
14	I-TUDO	I	Connected to TUNER PLL IC LC72131 pin-⑥ D0.
15	VSS1	—	GND.
16	CF1	I	5.76 MHz. Connected to oscillator.
17	CF2	O	
18	VDD1	—	Microprocessor power supply (μ -com 5V).
19	I-HOLD	I	Hold state detection. (Ignored by slave microprocessor)
20-22	P81-P83	—	NC.
23	I-TU-SIG	I	RDS signal level AD value input (A/D).
24-26	P85-P87	—	NC.
27	I-RDSCCLK	I	RDS CLK input.
28	I-TMBASE	I	Reference clock input for watch. Connected to PLL ICLC72131 pin-⑦.
29	P73	—	NC.
30-41	G13-G2	O	FL tube grid output. (13G-2G).
42, 43	P35, P34	O	FL tube anode output. (P35, P34).
44	G1	O	FL tube grid output. (1G).
45	P33	O	FL tube anode output. (P33).
46	VDD3	—	Microprocessor power supply. (μ -com 5V).
47-50	P32-P29	O	FL tube anode output. (P32-P29).
51	VP	—	Connected to minus power supply -VFL for FL.
52-71	P28-P9	O	FL tube anode output. (P28-P9).
72	VDD4	—	Microprocessor power supply. (μ -com 5V).
73-80	P8-P1	O	FL tube anode output. (P8-P1).
81	S48	—	NC.
82-84	PG1-PG3	—	
85, 86	P00, P01	—	
87	O-CE	O	Connected to TUNER PLL IC LC72131 pin-③ CE.
88	O-TUON	O	TUNER power supply. ON/OFF output.
89	VSS2	—	GND.

Pin No.	Pin Name	I/O	Description
90	VDD2	—	Microprocessor power supply. (μ -com 5V).
91, 92	P04, P05	—	NC.
93	O-MUTE	O	Main mute output.
94	P07	—	NC.
95-97	P10-12	—	
98	O-MASI	O	Serial data output to master microprocessor.
99	$\overline{\text{I-MASO}}$	I	Serial data input from master microprocessor.
100	I-MACLK	I	Transfer clock input from master microprocessor.

IC BLOCK DIAGRAM
IC, BU1920FS

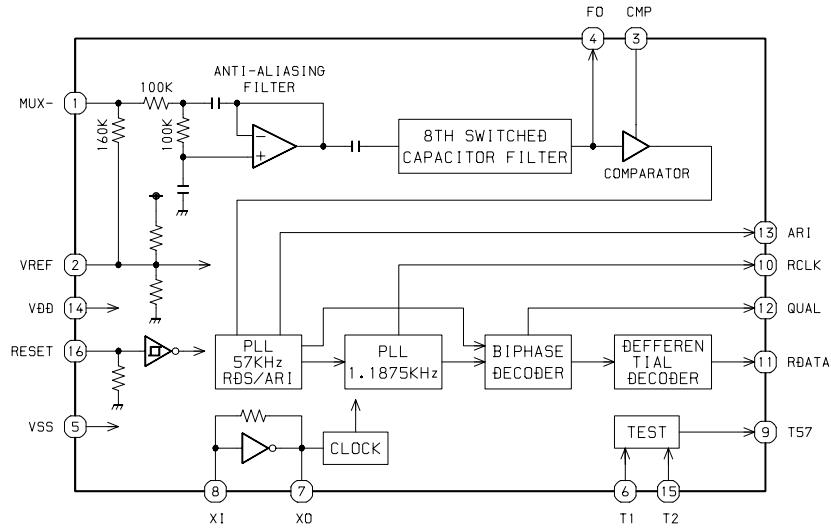

IC, LA1837

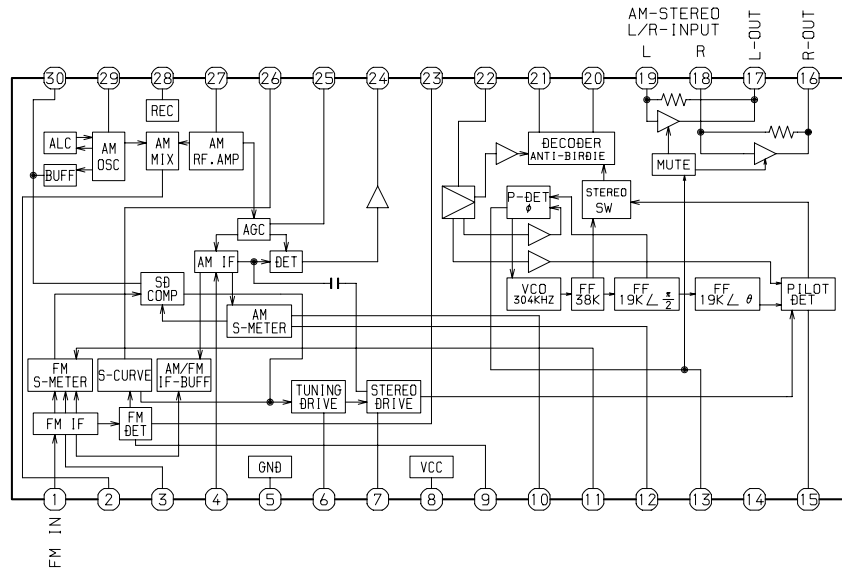

IC, LC72131

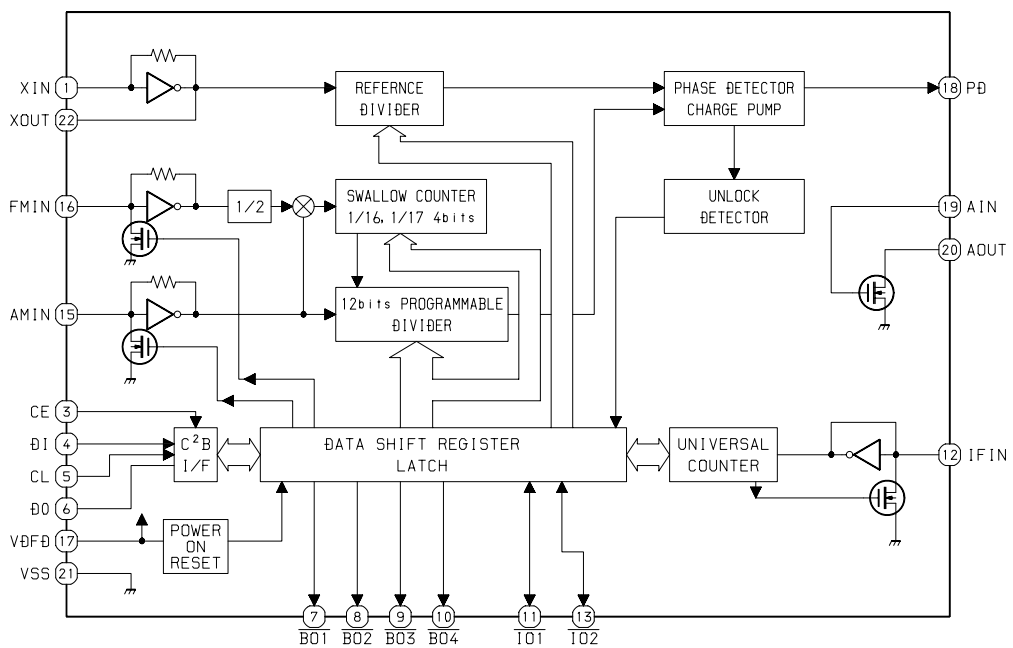

MECHANICAL EXPLODED VIEW 1/1

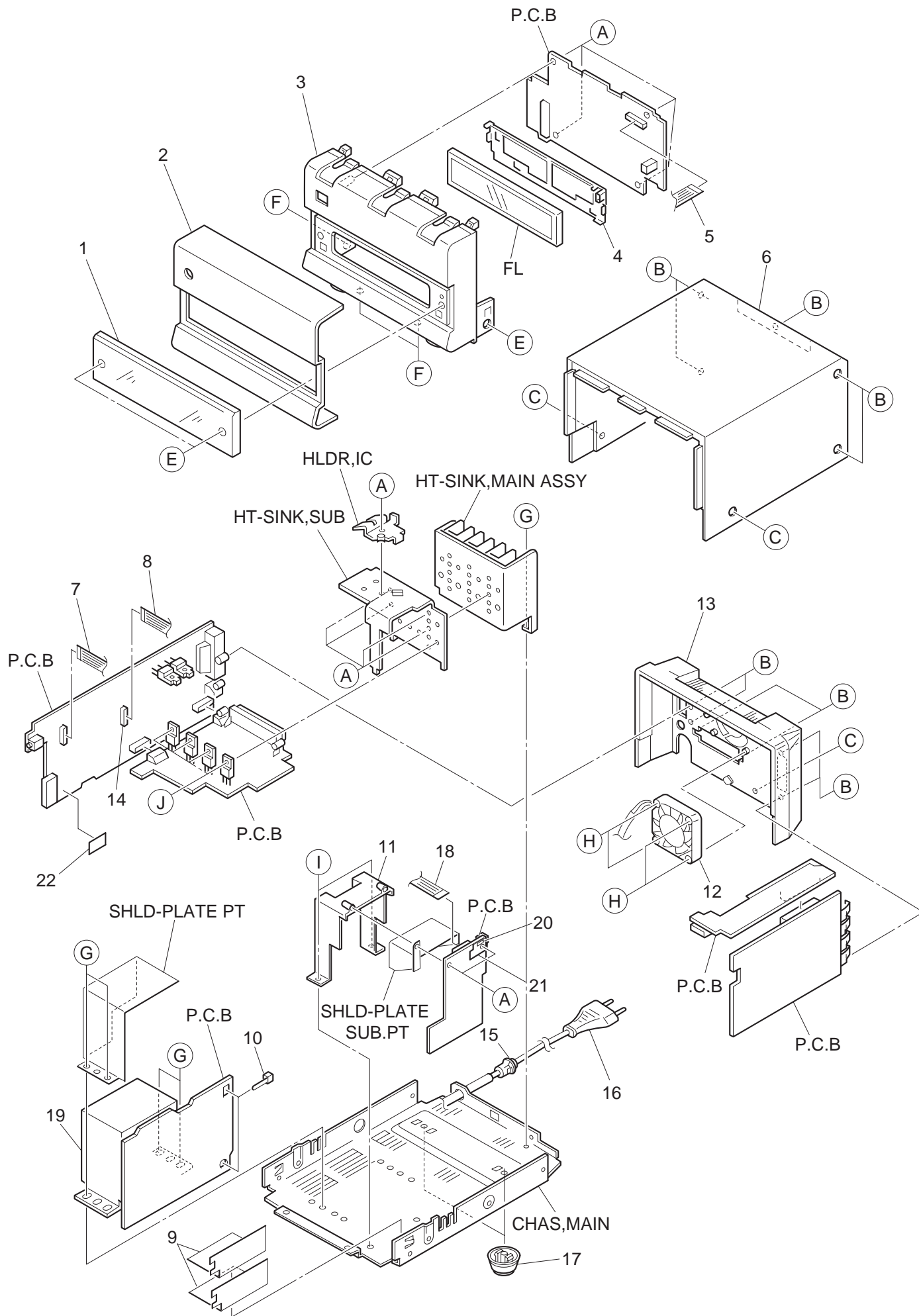

MECHANICAL PARTS LIST 1/1

DESCRIPTIONで判断できない物は "REFERENCE NAME LIST" を参照してください。
If can't understand for Description please kindly refer to "REFERENCE NAME LIST".

REF. NO	PART NO.	KANRI NO.	DESCRIPTION	REF. NO	PART NO.	KANRI NO.	DESCRIPTION
1	8Z-CL1-056-110		WINDOW,DISP EX	21	8Z-CL1-216-110		COVER, AC TERM
2	8Z-CLB-013-010		PANEL,RX CS	22	8Z-CLB-220-010		COVER, SCREW
3	8Z-CL1-001-110		CABI,FR RX	A	87-067-703-010		TAPPING SCREW, BVT2+3-10
4	8Z-CL1-204-010		HLDL,FL	B	87-744-095-410		UT2+3-8CR
5	88-910-131-110		FF-CABLE,10P 1.25	C	87-B10-068-010		UTT2+3-6 W/O SLOT CR
6	8Z-CL1-003-010		CABI, TOP RX	D	8Z-CL1-034-010		S-SCREW,ZCL1
7	8Z-CL1-655-010		F-CABLE,4P 2.5 100MM PWR	E	87-591-094-010		QIT+3-6 GOLD
8	8Z-CL1-656-010		F-CABLE,7P 2.5 150MM PWR	F	87-067-761-010		TAPPING SCREW, BVT2+3-10
9	8Z-CL1-215-110		COVER, PWB AC	G	87-067-585-010		TAPPING SCREW, BVTT+4-6
10	87-A90-193-010		HLDL,CV100 (B)	H	87-751-095-410		VT2+3-8
11	8Z-CL1-203-010		HLDL,SUB PT	I	87-067-584-010		TAPPING SCREW,BVT2+3-6
12	8Z-CL1-663-010		FAN,MF40D-12-200MM	J	87-067-981-010		BVT2+3-6 BLK
13	8Z-CLB-075-010		PANEL,REAR RX CS HC				
14	87-A90-460-010		HLDL,WIRE 2.5-7P				
15	87-085-185-010		BUSHING, AC CORD (E)				
▲	16	87-A80-092-010	AC CORD ASSY,E BLK SUN FAI				
	17	81-669-025-010	FOOT, H11				
	18	8Z-CL1-654-010	F-CABLE,2P 2.5 170MM SUBPT				
▲	19	8Z-CL1-624-010	PT,H				
	20	8Z-CL1-217-010	COVER, AC SUB				

COLOR NAME TABLE

Basic color symbol	Color	Basic color symbol	Color	Basic color symbol	Color
B	Black	C	Cream	D	Orange
G	Green	H	Gray	L	Blue
LT	Transparent Blue	N	Gold	P	Pink
R	Red	S	Silver	ST	Titan Silver
T	Brown	V	Violet	W	White
WT	Transparent White	Y	Yellow	YT	Transparent Yellow
LM	Metallic Blue	LL	Light Blue	GT	Transparent Green
LD	Dark Blue	DT	Transparent Orange		

MODEL NO. FD-LM88

DISASSEMBLY INSTRUCTIONS

1. Remove the two screws.

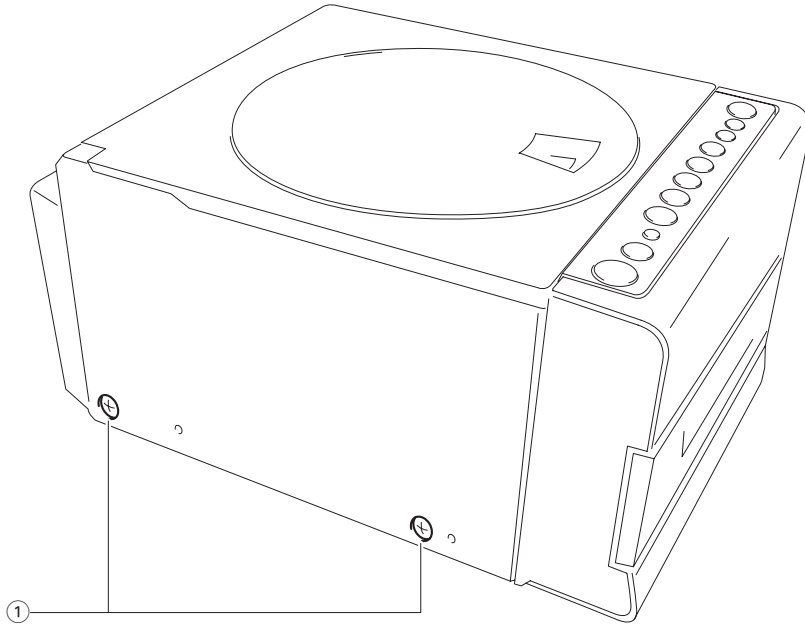

2. Remove the two screws.

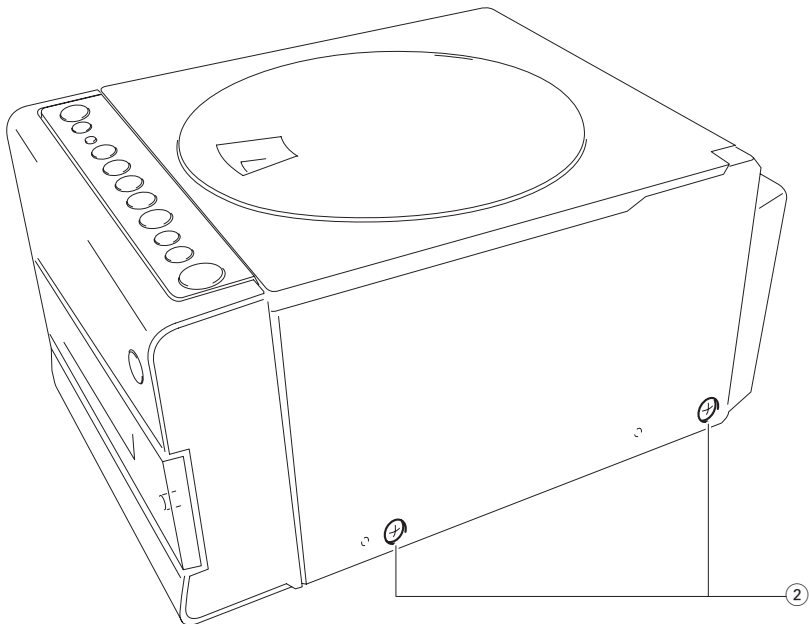

3. Remove the eight screws and remove the PANEL, REAR FD.

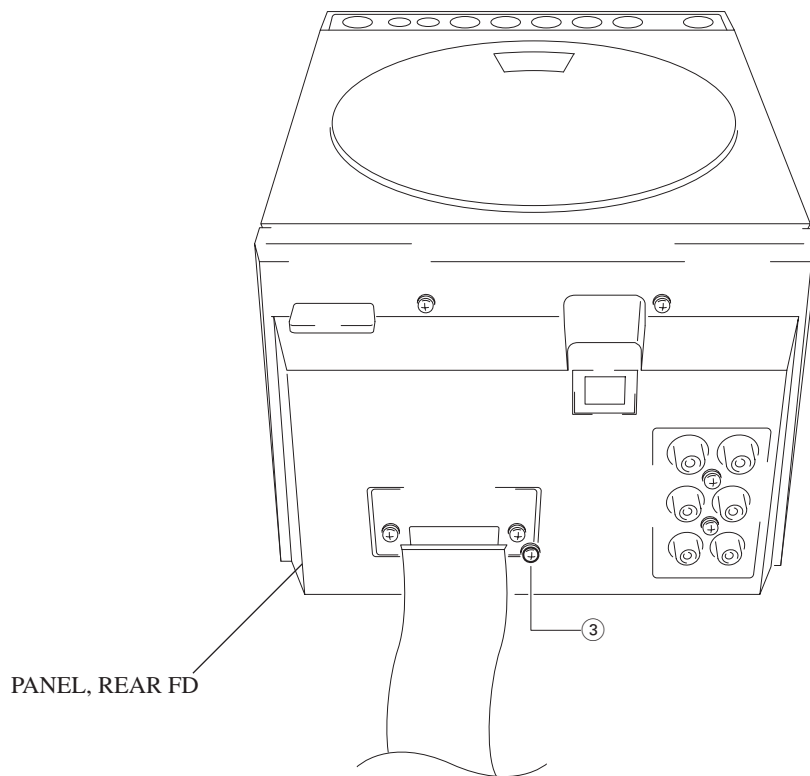

4. While moving up the rear of the PANEL, TOP, remove the PANEL, TOP by pulling it to the front.

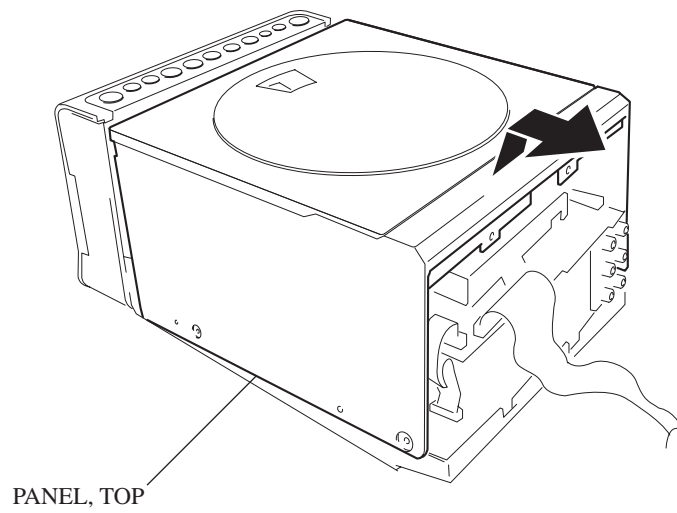

5. Remove the FFC and cord. Be careful that the FFC especially cannot be removed easily.

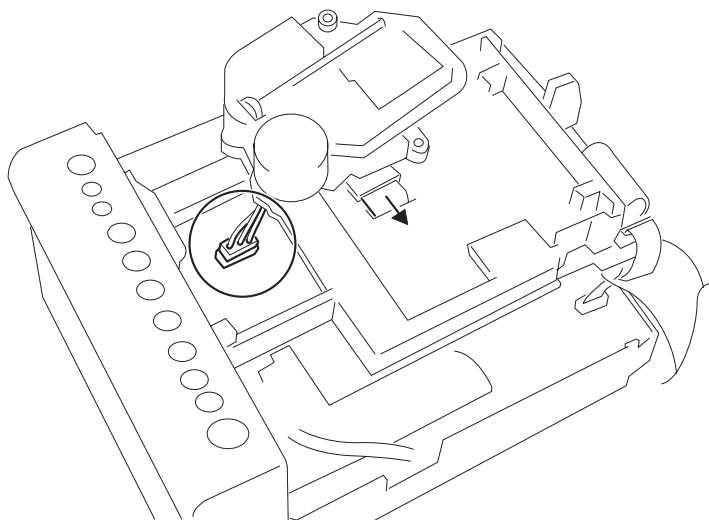

6. Remove the screws.

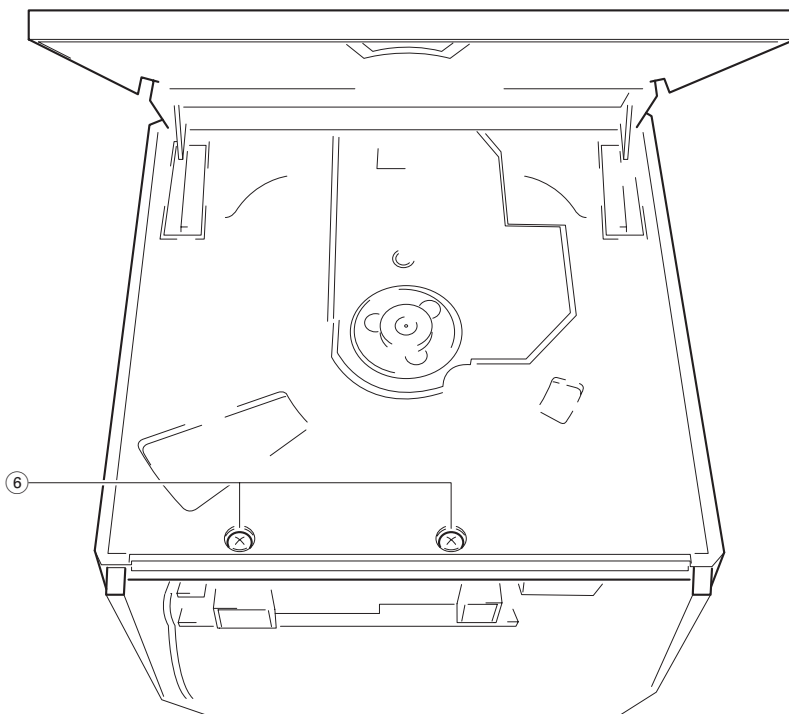

7. Remove the two FFCs.

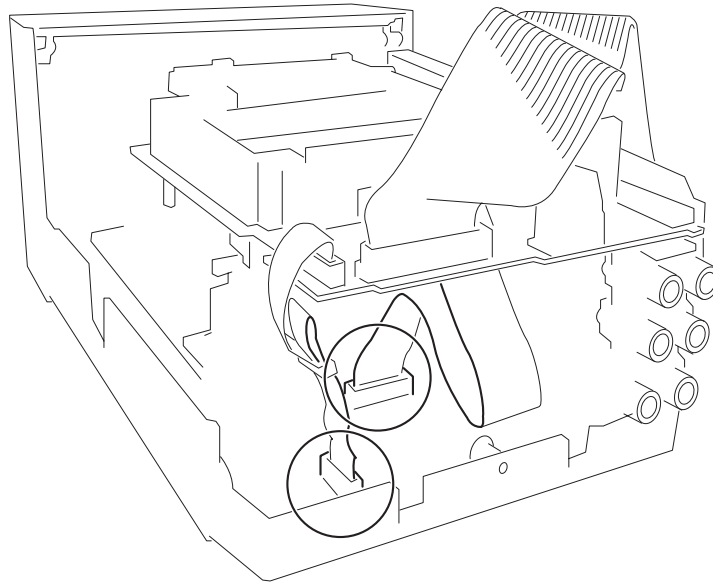

8. Remove the claw and remove the CABI FRFD together with the entire front board.

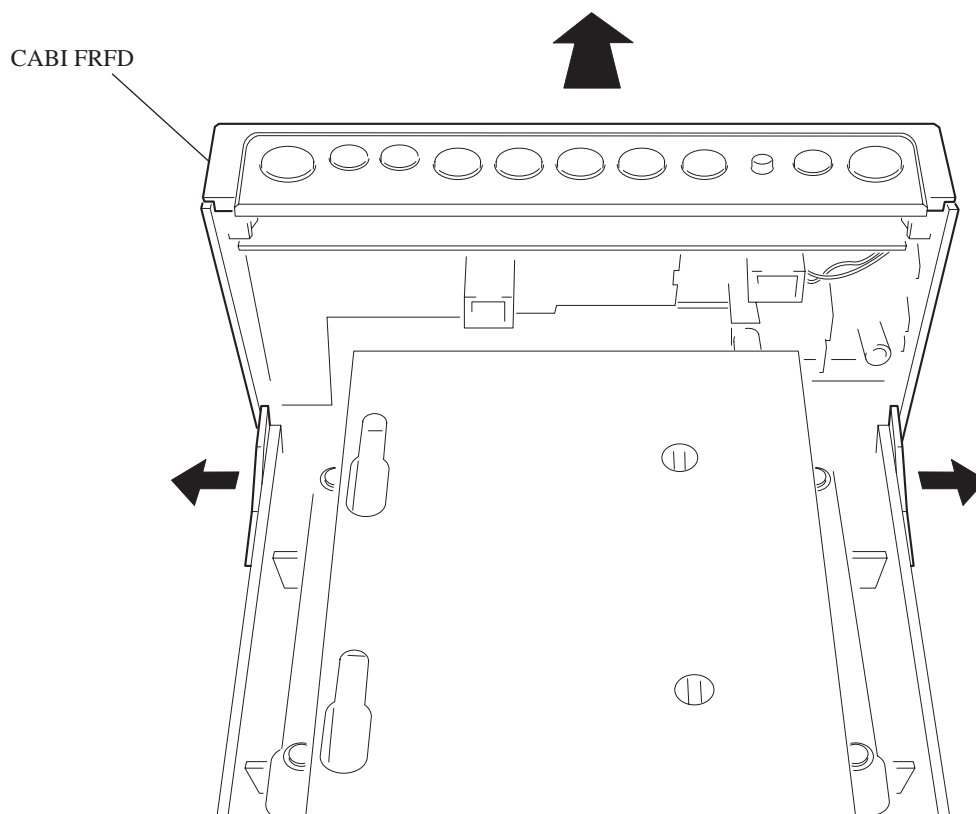

9. While moving up the CD board and the function board, remove the CD board and the function board. You can locate the mechanism deck.

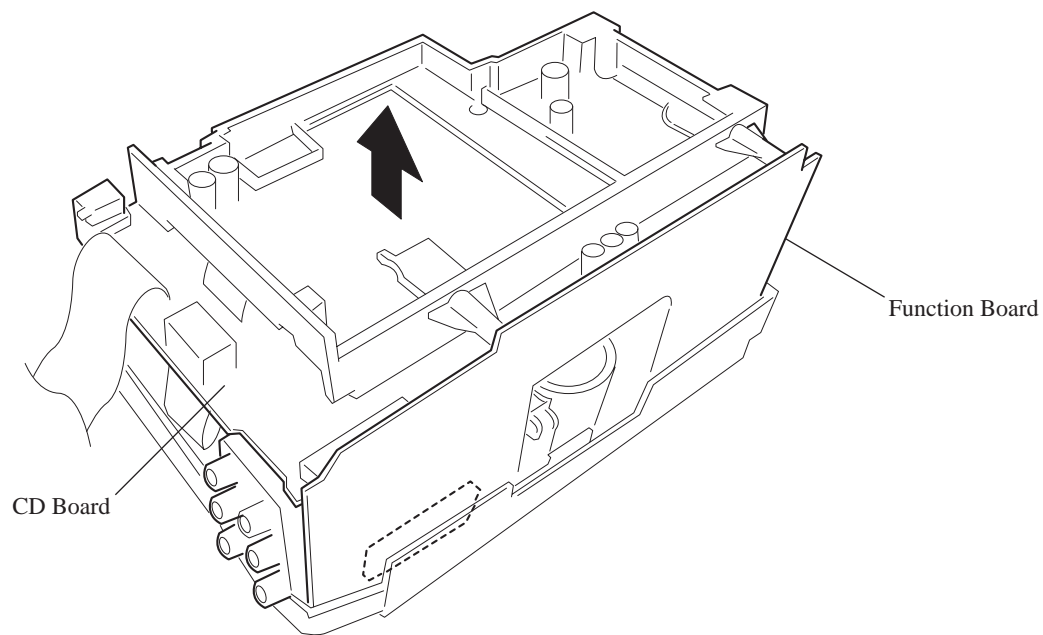

ELECTRICAL MAIN PARTS LIST

DESCRIPTIONで判断できない物は "REFERENCE NAME LIST" を参照してください。
 If can't understand for Description please kindly refer to "REFERENCE NAME LIST".

REF. NO	PART NO.	KANRI NO.	DESCRIPTION	REF. NO	PART NO.	KANRI NO.	DESCRIPTION
IC				C35	87-010-197-080		CAP, CHIP 0.01 DM
	87-A20-446-010	C-IC, LA9241ML		C36	87-010-553-040		CAP,E 47-16 GAS
	87-A20-459-010	C-IC, LC78622ED		C37	87-010-404-040		CAP,E 4.7-50 SME
	87-A20-445-010	IC, BA5936		C38	87-010-196-080		CHIP CAPACITOR, 0.1-25
	8Z-CLB-621-010	C-IC, LC866560-5M02FD		C40	87-010-145-080		C-CAP,S 1P-50 CH
	87-A20-455-010	IC, HA12211		C42	87-010-315-080		C-CAP,S 27P-50 CH
	87-001-982-010	IC, TA7291S		C45	87-010-196-080		CHIP CAPACITOR, 0.1-25
	87-A21-111-040	C-IC, M62495FP		C46	87-010-196-080		CHIP CAPACITOR, 0.1-25
	87-A21-022-040	C-IC, BA3880FS		C47	87-010-196-080		CHIP CAPACITOR, 0.1-25
	87-A21-103-040	C-IC, MM1454XFBE		C48	87-010-315-080		C-CAP,S 27P-50 CH
	87-017-888-080	IC, NJM4558MD		C50	87-012-140-080		CAP 470P
	87-A20-914-010	IC, SPS-442-1-F		C51	87-012-156-080		C-CAP,S 220P-50 CH
				C55	87-010-264-040		CAP,E 100-10 5L
				C57	87-010-316-080		C-CAP,S 33P-50 CH
				C58	87-010-316-080		C-CAP,S 33P-50 CH
TRANSISTOR				C59	87-010-264-040		CAP,E 100-10 5L
	87-026-463-080	TR, 2SA933S (0.3W)		C60	87-010-196-080		CHIP CAPACITOR, 0.1-25
	89-113-184-080	TR, 2SA1318T		C61	87-010-196-080		CHIP CAPACITOR, 0.1-25
	87-026-297-080	TR, DTA144TK		C62	87-010-370-040		CAP,E 330-6.3 SME
	87-026-239-080	TR, DTC114TK (0.2W)		C65	87-010-497-040		CAP,E 4.7-35 GAS
	87-A30-047-080	TR, CSD655E		C66	87-010-196-080		CHIP CAPACITOR, 0.1-25
	87-A30-075-080	C-TR, 2SA1235F		C67	87-010-264-040		CAP,E 100-10 5L
	87-026-610-080	TR, KTC3198GR		C68	87-010-322-080		C-CAP,S 100P-50 CH
	87-A30-083-080	TR, CSD1489B		C75	87-010-197-080		CAP, CHIP 0.01 DM
	87-A30-071-080	C-TR, RT1N 144C		C76	87-A10-102-080		CAP,E 1000-10 REA
	87-A30-087-080	C-FET, 2SK2158		C79	87-010-264-040		CAP,E 100-10 5L
	89-320-011-080	TR, 2SC2001K		C80	87-010-197-080		CAP, CHIP 0.01 DM
	87-026-609-080	TR, KTA1266GR		C81	87-010-560-040		CAP,E 10-50 GAS
	87-A30-076-080	C-TR, 2SC3052F		C82	87-010-560-040		CAP,E 10-50 GAS
				C83	87-012-157-080		C-CAP,S 330P-50 CH
DIODE				C84	87-012-157-080		C-CAP,S 330P-50 CH
	87-020-465-080	DIODE, 1SS133 (110MA)		C93	87-010-197-080		CAP, CHIP 0.01 DM
	87-A40-270-080	C-DIODE, MC2838		C94	87-010-197-080		CAP, CHIP 0.01 DM
	87-A40-509-080	ZENER, MTZJ6.8C		C98	87-012-154-080		C-CAP,S 150P-50 CH
	87-070-274-080	DIODE, 1N4003 SEM		C102	87-010-322-080		C-CAP,S 100P-50 CH
	87-A40-269-080	C-DIODE, MC2836		C104	87-010-322-080		C-CAP,S 100P-50 CH
	87-017-931-080	ZENER, MTZJ5.6B		C105	87-010-322-080		C-CAP,S 100P-50 CH
	87-A40-292-080	ZENER, DZ2.7L		C110	87-010-196-080		CHIP CAPACITOR, 0.1-25
	87-001-731-080	ZENER, HZS6C2L		C141	87-016-460-080		C-CAP,S 0.22-16 B
				C146	87-010-560-040		CAP,E 10-50 GAS
CD C.B				C150	87-010-264-040		CAP,E 100-10 5L
C1	87-010-496-040	CAP,E 3.3-50 GAS		C151	87-010-197-080		CAP, CHIP 0.01 DM
C2	87-010-197-080	CAP, CHIP 0.01 DM		C201	87-012-145-080		CAP, CHIP S 270P CH
C3	87-010-264-040	CAP,E 100-10 5L		C203	87-010-312-080		C-CAP,S 15P-50 CH
C4	87-A10-189-040	CAP,E 220-10		C204	87-015-785-080		CHIP CAPACITOR, 0.1FZ-25Z
C5	87-010-197-080	CAP, CHIP 0.01 DM		C205	87-010-196-080		CHIP CAPACITOR, 0.1-25
C6	87-010-553-040	CAP,E 47-16 GAS		C210	87-012-349-080		C-CAP,S 1000P-50 CH
C7	87-012-349-080	C-CAP,S 1000P-50 CH		C217	87-010-498-040		CAP,E 10-16 GAS
C8	87-010-198-080	CAP, CHIP 0.022		C220	87-010-197-080		CAP, CHIP 0.01 DM
C9	87-010-264-040	CAP,E 100-10 5L		C221	87-010-235-080		CAP,E 470-16 SME
C10	87-010-264-040	CAP,E 100-10 5L		C222	87-010-101-080		CAP, ELECT 220-16
C12	87-010-494-040	CAP,E 1-50 GAS		C223	87-010-381-080		CAP, ELECT 330-16V
C13	87-010-193-080	CHIP CAPACITOR, 0.033		C224	87-010-197-080		C\CAP,S 0.01-25 K B C2012
C14	87-010-560-040	CAP,E 10-50 GAS		C241	87-010-493-040		CAP,E 0.47-50 GAS
C16	87-010-491-040	CAP,E 0.22-50 GAS		C242	87-A10-759-040		CAP,E 330-6.3 SRM
C17	87-012-349-080	C-CAP,S 1000P-50 CH		C243	87-010-196-080		CHIP CAPACITOR, 0.1-25
C18	87-010-213-080	C-CAP,S 0.015-50 B		C246	87-010-196-080		CHIP CAPACITOR, 0.1-25
C20	87-010-193-080	CHIP CAPACITOR, 0.033		C251	87-010-194-080		CAP, CHIP 0.047
C22	87-010-184-080	CHIP CAPACITOR 3300P(K)		C254	87-010-264-040		CAP,E 100-10 5L
C23	87-010-992-080	C-CAP,S 0.047-25 B		C473	87-010-221-080		CAP, ELECT 470-10V
C25	87-012-349-080	C-CAP,S 1000P-50 CH		C474	87-010-197-080		CAP, CHIP 0.01 DM
C27	87-010-176-080	C-CAP,S 680P-50 SL		CN1	87-A60-429-010		CONN, 16P H TOC-A
C29	87-010-186-080	CAP, CHIP 4700P		CN2	87-009-411-010		CONN, 6P ZH V
C30	87-012-156-080	C-CAP,S 220P-50 CH		CN3	87-A60-111-010		CONN, 5P V S2M 5W
C31	87-010-493-040	CAP,E 0.47-50 GAS		CN201	87-A60-424-010		CONN, 16P V TOC-B
C32	87-010-553-040	CAP,E 47-16 GAS		CN202	87-A60-957-010		CONN, 9P V TOC-B
C33	87-010-494-040	CAP,E 1-50 GAS		CN203	87-A60-826-010		CONN, 6P B TMC-D(X)
C34	87-010-184-080	CHIP CAPACITOR 3300P(K)		CN204	87-099-559-010		CONN, 13P TUC-P13X-B1
				D150	87-A40-558-010		LED, SLZ-8128A-01-A
				L1	87-003-102-080		COIL, 10UH

REF. NO	PART NO.	KANRI NO.	DESCRIPTION	REF. NO	PART NO.	KANRI NO.	DESCRIPTION
L4	87-003-152-080		COIL, 100UH	SFR452	87-024-436-080		SFR,47K RH063EC
L150	87-003-171-010		COIL, 15UH FL5R100				
L201	87-A50-052-010		COIL,CLOCK 5.76MHZ T1				
SFR130	87-A90-787-080		SFR,100K H HOKU				FUNCTION C.B
W201	8Z-CL1-653-010		F-CABLE,19P 1.5 FG				
WH201	87-A90-878-010		HLDR,WIRE 19P 1.5 51016				
X1	87-A70-046-010		VIB,XTAL 16.934MHZ				
TAPE C.B							
C90	87-010-197-080		CAP, CHIP 0.01 DM	C501	87-010-197-080		CAP, CHIP 0.01 DM
C91	87-015-684-040		CAP,E 47-16 7L	C531	87-010-374-040		CAP,E 47-10
C92	87-015-686-040		CAP,E 22-25 M 7L SRA	C532	87-010-374-040		CAP,E 47-10
C303	87-012-157-080		C-CAP,S 330P-50 CH	C535	87-010-213-080		C-CAP,S 0.015-50 B
C304	87-012-157-080		C-CAP,S 330P-50 CH	C536	87-010-213-080		C-CAP,S 0.015-50 B
C307	87-010-196-080		CHIP CAPACITOR,0.1-25				
C311	87-010-198-080		CAP, CHIP 0.022	C537	87-010-400-040		CAP,E 0.47-50
C312	87-010-198-080		CAP, CHIP 0.022	C538	87-010-400-040		CAP,E 0.47-50
C315	87-010-182-080		C-CAP,S 2200P-50	C539	87-010-564-040		CAP,E 0.33-50 M
C316	87-010-182-080		C-CAP,S 2200P-50	C540	87-010-564-040		CAP,E 0.33-50 M
C321	87-A10-201-080		C-CAP,S0.33-16 KB	C541	87-010-401-040		CAP,E 1-50 SME
C322	87-A10-201-080		C-CAP,S0.33-16 KB				
C325	87-010-807-080		CAP,E 330-6.3 SR	C542	87-010-401-040		CAP,E 1-50 SME
C327	87-015-692-040		CAP,E 0,22-50 KB	C543	87-010-154-080		CAP CHIP 10P
C328	87-015-692-040		CAP,E 0,22-50 KB	C583	87-010-182-080		C-CAP,S 2200P-50 K B
C332	87-010-196-080		CHIP CAPACITOR,0.1-25	C584	87-010-182-080		C-CAP,S 2200P-50 K B
C335	87-015-695-040		E/CAP 1UF 50V TAPG	C591	87-010-180-080		C-CER 1500P
C336	87-015-695-040		E/CAP 1UF 50V TAPG				
C337	87-010-196-080		CHIP CAPACITOR,0.1-25	C592	87-010-180-080		C-CER 1500P
C351	87-012-140-080		CAP 470P	C603	87-010-402-040		CAP,E 2.2-50 SME
C352	87-012-140-080		CAP 470P	C604	87-010-402-040		CAP,E 2.2-50 SME
C354	87-010-175-080		CAP 560P	C605	87-010-408-040		CAP,E 47-50 SME
C355	87-010-176-080		C-CAP,S 680P-50 J	C607	87-010-405-040		CAP,E 10-50
C356	87-015-684-040		CAP,E 47-16 7L				
C358	87-010-187-080		C-CAP,S 5600P-50 K B	C608	87-010-405-040		CAP,E 10-50
C359	87-010-197-080		C-CAP,S 0.01-25 K B	C609	87-010-196-080		CHIP CAPACITOR,0.1-25
C360	87-010-187-080		C-CAP,S 5600P-50 J	C610	87-010-384-040		CAP,E 100-25 SME
C370	87-010-196-080		CHIP CAPACITOR,0.1-25	C611	87-010-197-080		CAP, CHIP 0.01 DM
C379	87-015-697-040		CAP,E 3.3-50 M 7L SRA	C612	87-010-197-080		CAP, CHIP 0.01 DM
C380	87-015-697-040		CAP,E 3.3-50 M 7L SRA				
C391	87-012-153-080		C-CAP,S 120P-50 J CH	C621	87-010-401-040		CAP,E 1-50 SME
C392	87-012-153-080		C-CAP,S 120P-50 J CH	C622	87-010-401-040		CAP,E 1-50 SME
C399	87-015-683-040		CAP,E 33-16 M 7L SRA	C653	87-010-404-040		CAP,E 4.7-50 SME
C401	87-010-197-080		CAP, CHIP 0.01 DM	C654	87-010-404-040		CAP,E 4.7-50 SME
C402	87-010-060-040		CAP,E 100-16	C655	87-010-404-040		CAP,E 4.7-50 SME
C403	87-015-684-040		CAP,E 47-16 7L				
C404	87-A10-924-040		CAP,E 47-16 BP SME	C656	87-010-404-040		CAP,E 4.7-50 SME
C441	87-015-677-040		CAP,E 100-6.3 7L	C657	87-010-188-080		CAP,CHIP 6800P
C442	87-018-211-080		CAP, CER 0.01-50	C658	87-010-188-080		CAP,CHIP 6800P
C454	87-010-175-080		CAP 560P	C659	87-012-140-080		CAP 470P
C455	87-010-176-080		C-CAP,S 680P-50 CH	C660	87-012-140-080		CAP 470P
C456	87-015-684-040		CAP,E 47-16 7L				
C458	87-010-187-080		C-CAP,S 5600P-50 KB	C662	87-010-260-040		CAP,E 47-25 SME
C459	87-010-197-080		C-CAP,S 0.01-25 KB	C665	87-010-197-080		CAP, CHIP 0.01 DM
C460	87-010-187-080		C-CAP,S 5600P-50 K B	C666	87-010-197-080		CAP, CHIP 0.01 DM
CN301	87-A60-957-010		CONN,9P V TOC-B	C667	87-010-598-080		C-CAP,S 0.068-16VRK
CN302	87-A60-057-010		CONN,11P V 9604S-11C	C668	87-010-598-080		C-CAP,S 0.068-16VRK
CN401	87-A60-424-010		CONN,16P V TOC-B				
CN402	87-A60-957-010		CONN,9P V TOC-B	C669	87-010-260-040		CAP,E 47-25 SME
CN403	87-099-668-010		CONN,9P TUC-P 9P-B1	C670	87-010-196-080		CHIP CAPACITOR,0.1-25
L301	87-A50-049-010		COIL,TRAP 85K(COI)	C671	87-010-545-040		CAP,E 0.22-50
L302	87-A50-049-010		COIL,TRAP 85K(COI)	C672	87-010-545-040		CAP,E 0.22-50
L351	87-A50-500-010		COIL,OSC BIAS 85KHZ	C677	87-010-404-040		CAP,E 4.7-50 SME
L451	87-A50-500-010		COIL,OSC BIAS 85KHZ				
RY301	87-A91-375-010		RELAY,AC DC12V G6S-2	C678	87-010-404-040		CAP,E 4.7-50 SME
RY302	87-A91-375-010		RELAY,AC DC12V G6S-2	C721	87-010-401-040		CAP,E 1-50 SME
RY303	87-A91-375-010		RELAY,AC DC12V G6S-2	C722	87-010-401-040		CAP,E 1-50 SME
SFR351	87-024-436-080		SFR,47K RH063EC	C723	87-012-154-080		C-CAP,S 150P-50 CH
SFR352	87-024-436-080		SFR,47K RH063EC	C724	87-012-154-080		C-CAP,S 150P-50 CH
SFR451	87-024-436-080		SFR,47K RH063EC				
				C725	87-012-154-080		C-CAP,S 150P-50 CH
				C726	87-012-154-080		C-CAP,S 150P-50 CH
				C727	87-010-404-040		CAP,E 4.7-50 SME
				C728	87-010-404-040		CAP,E 4.7-50 SME
				C733	87-010-197-080		CAP, CHIP 0.01 DM
				C734	87-010-381-080		CAP, ELECT 330-16V
				C735	87-010-197-080		CAP, CHIP 0.01 DM
				C851	87-A10-201-080		C-CAP,S0.33-16 KB
				C852	87-010-384-040		CAP,E 100-25 SME
				C853	87-010-400-040		CAP,E 0.47-50
				C854	87-010-402-040		CAP,E 2.2-50 SME
				CN503	87-099-670-010		CONN,9P TUC-P9X-B1
				CN504	87-099-570-010		CONN,13P TUC-P13P-B1
				J501	82-MA2-631-010		JACK PIN 4P RVS
				J701	87-A60-354-010		JACK,PIN 2P MSP -242V-05

TRANSISTOR ILLUSTRATION

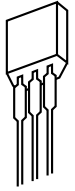

ECB

2SA933



ECB

2SA1318
2SC2001
CSD655E
CSD1489B
KTC3198



ECB

KTA1266

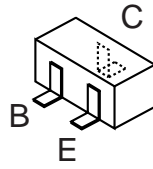

2SA1235
2SC3052
DTA144TK
DTC114TK
RT1N144C

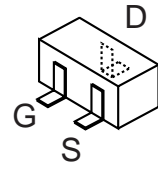

2SK2158

CD C.B (COMPONENT SIDE)

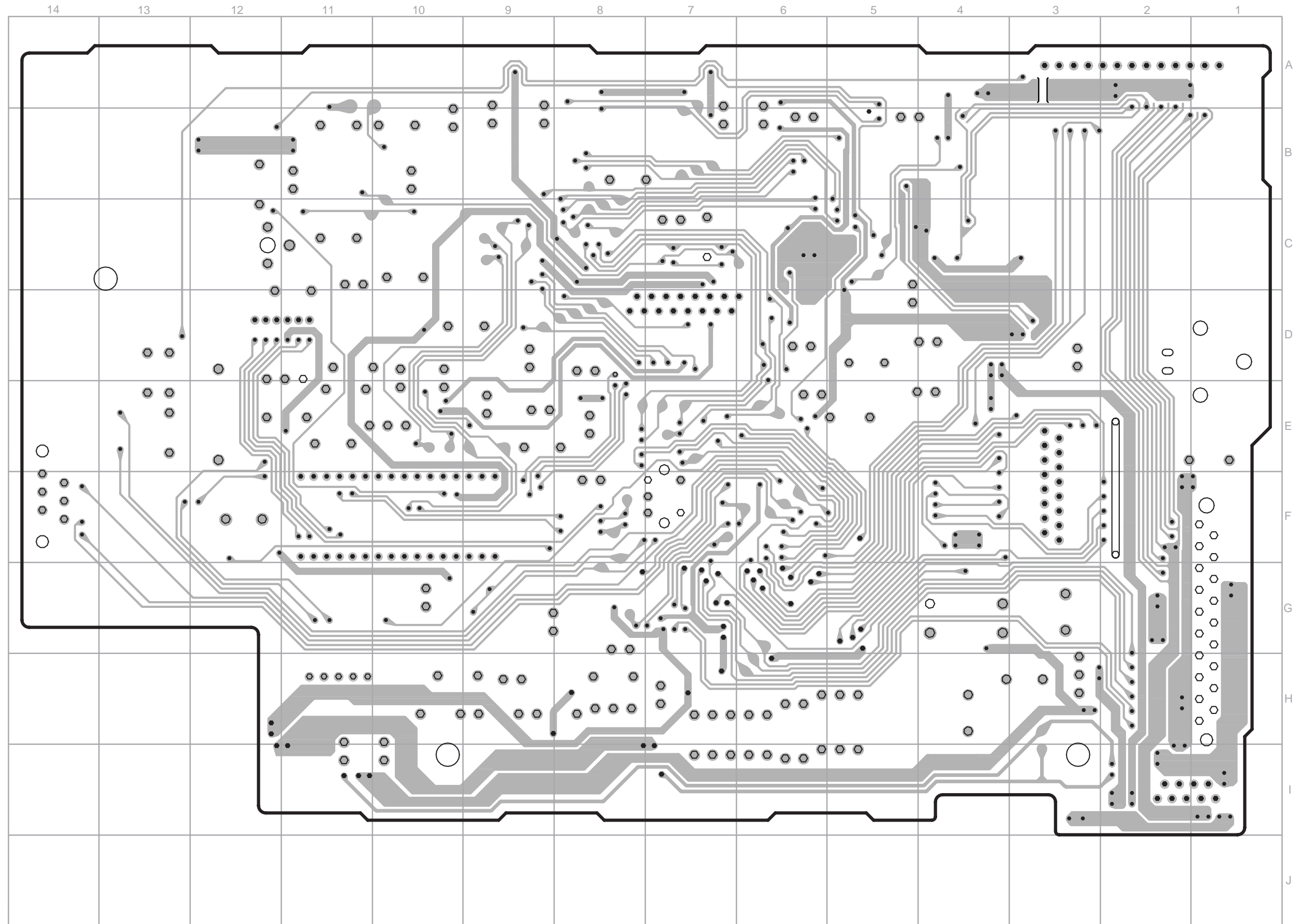

CD C.B (CONDUCTOR SIDE)

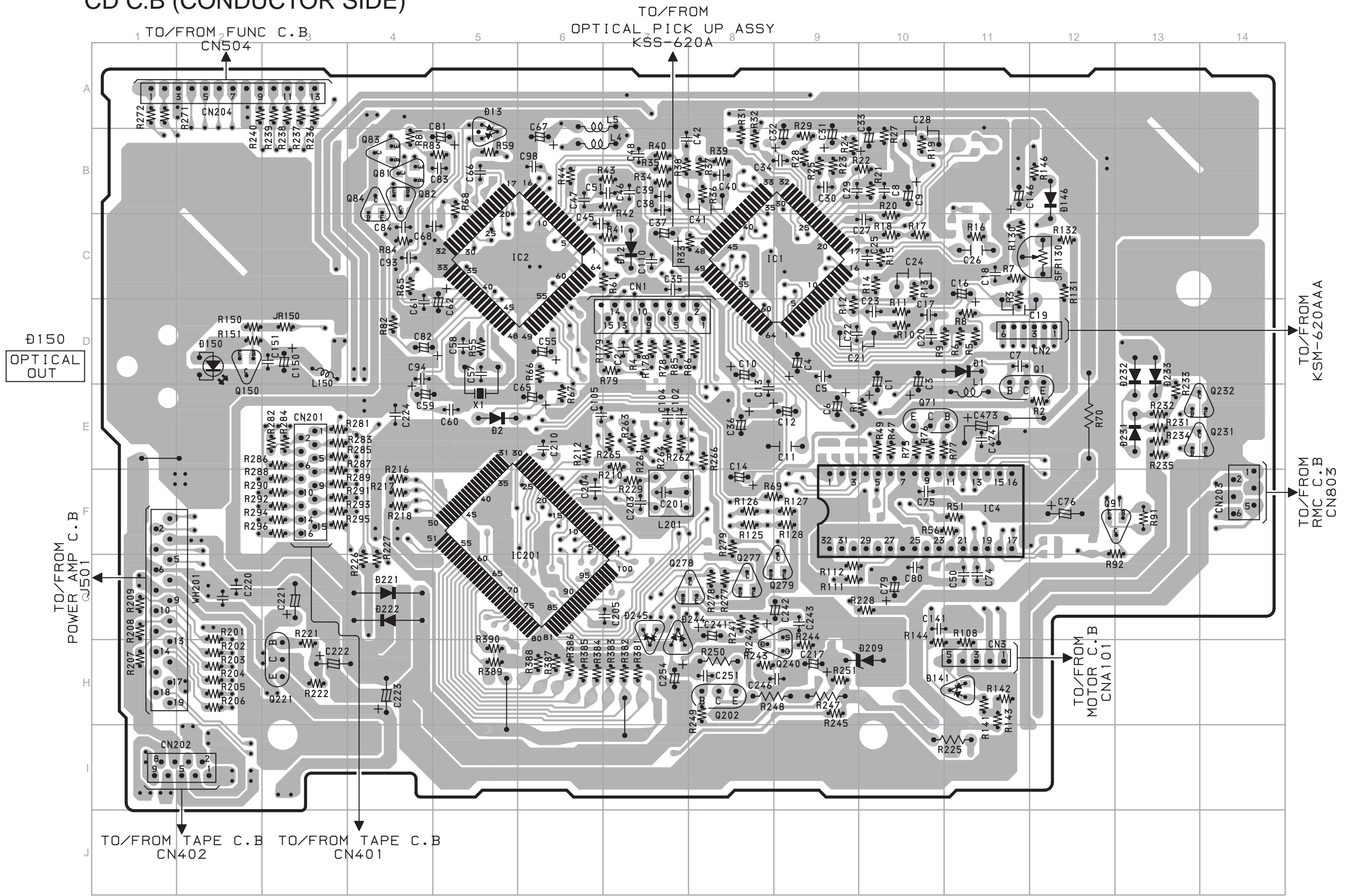

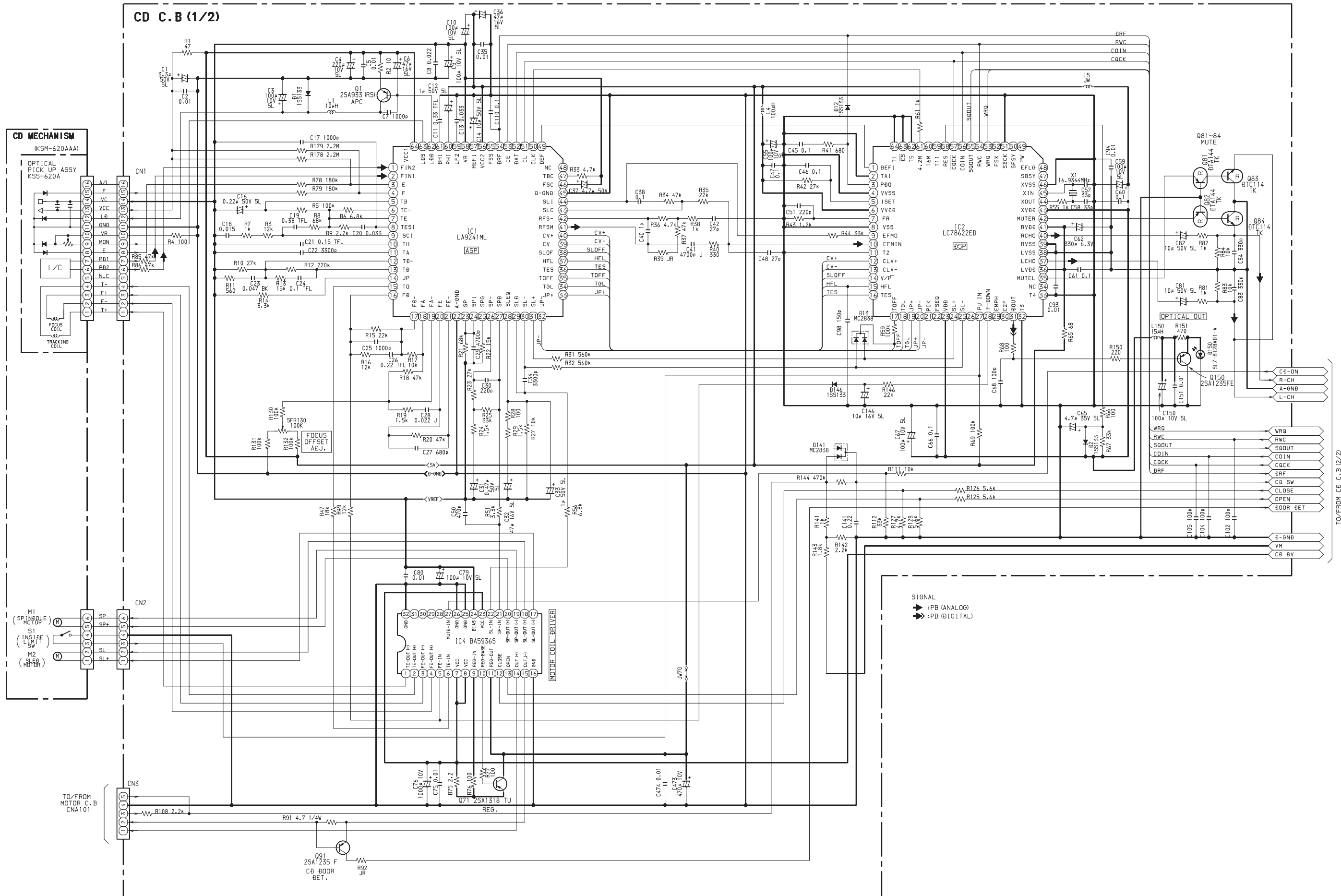

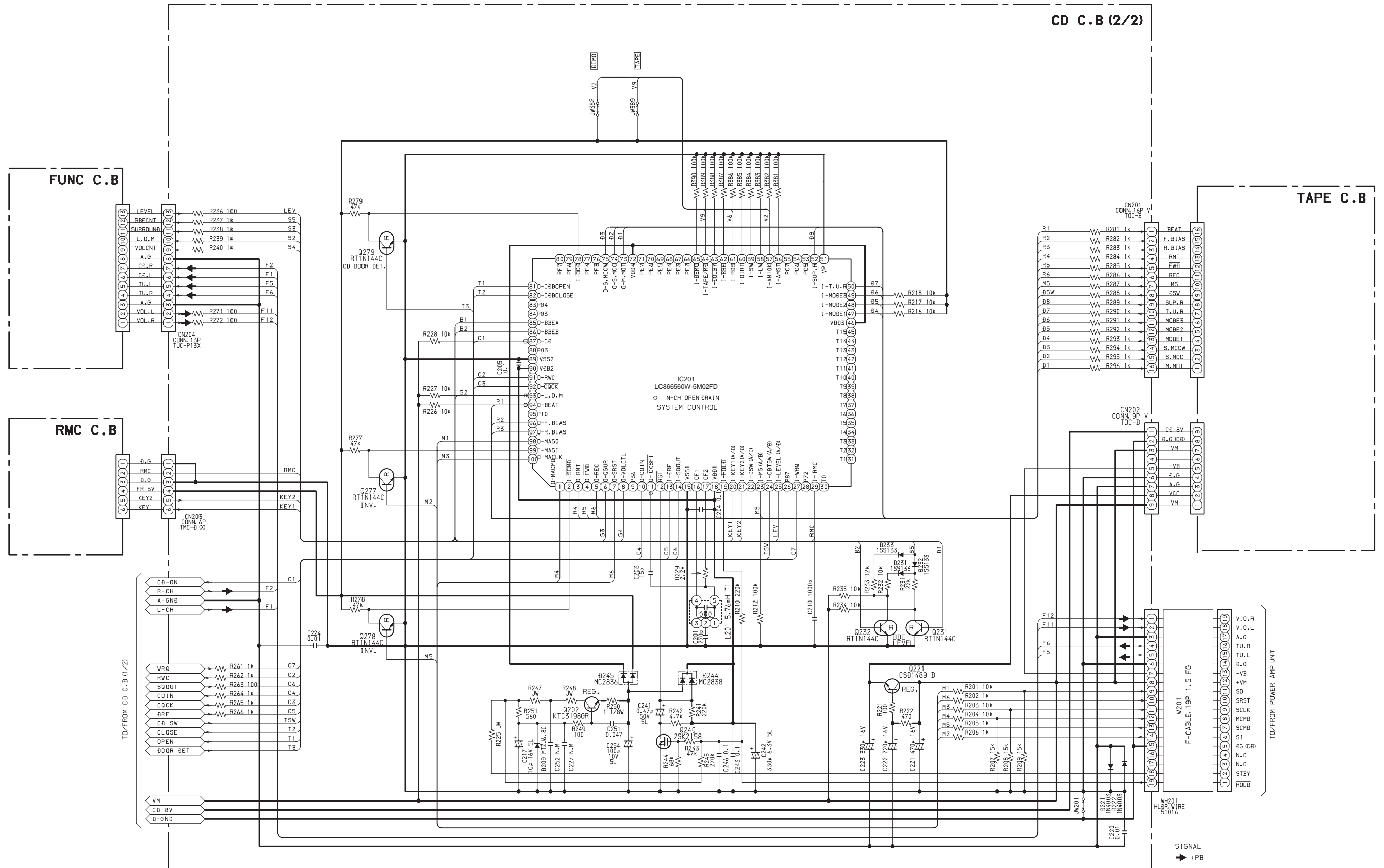

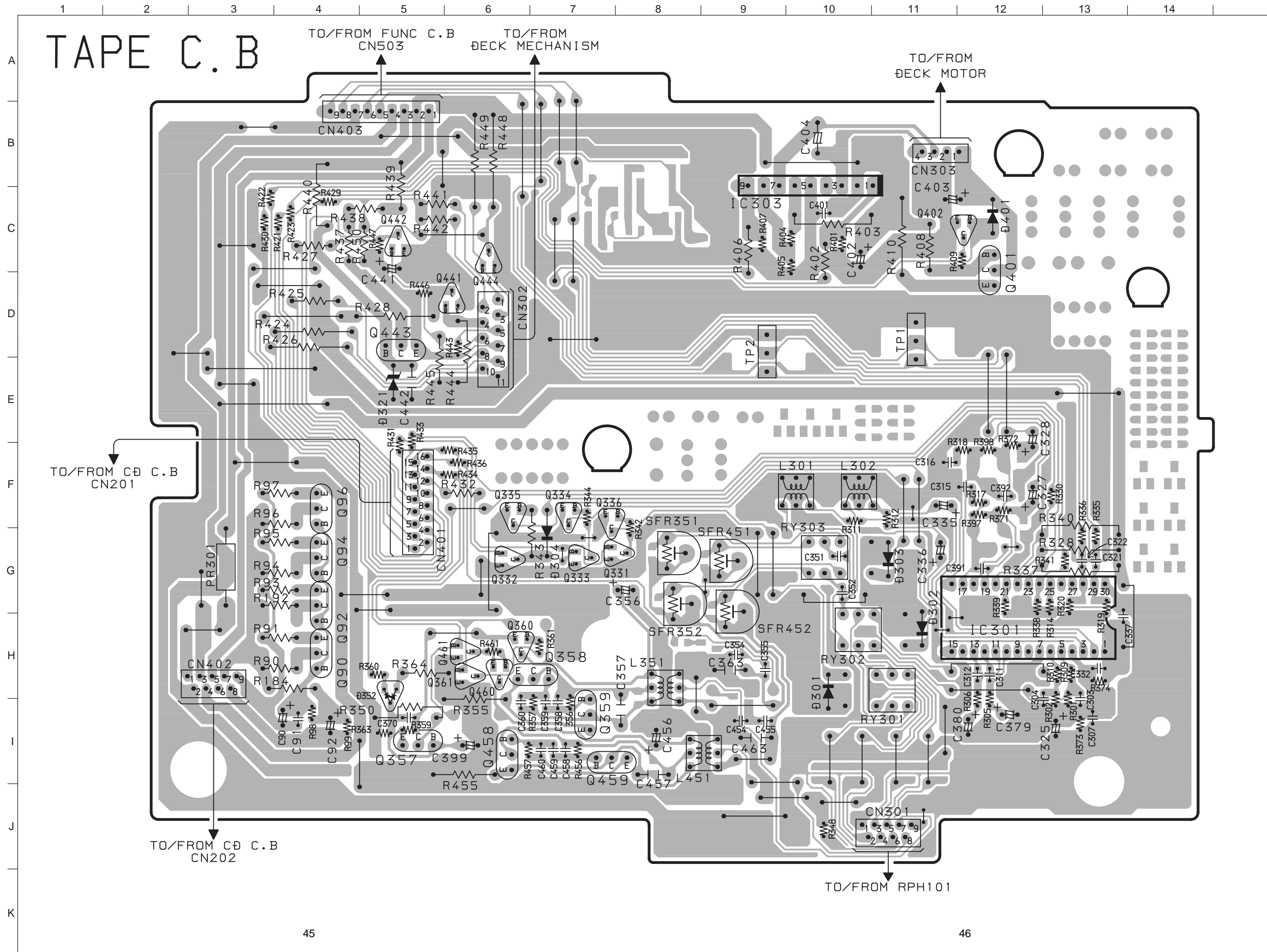

WIRING-3 (KEY)

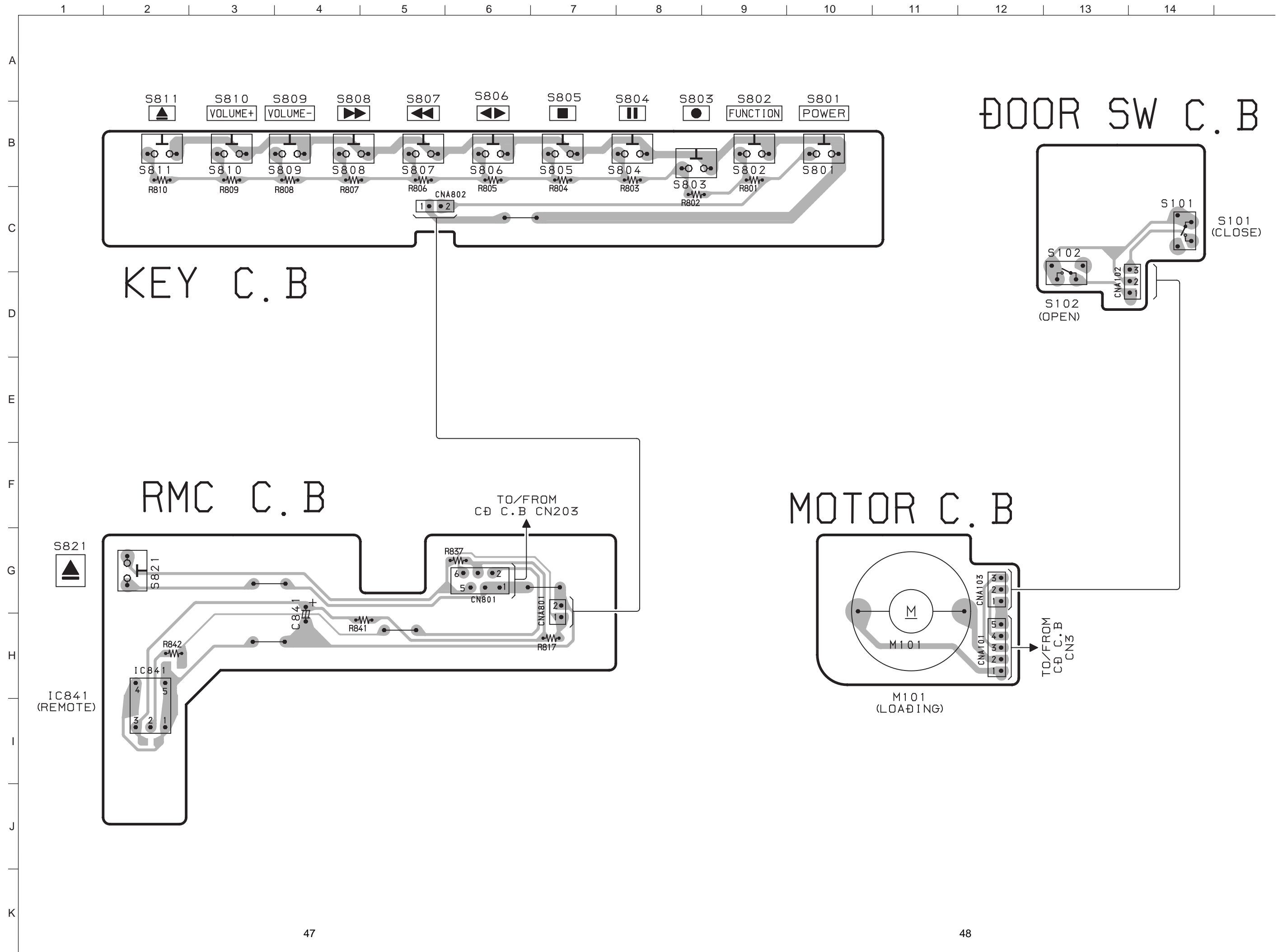

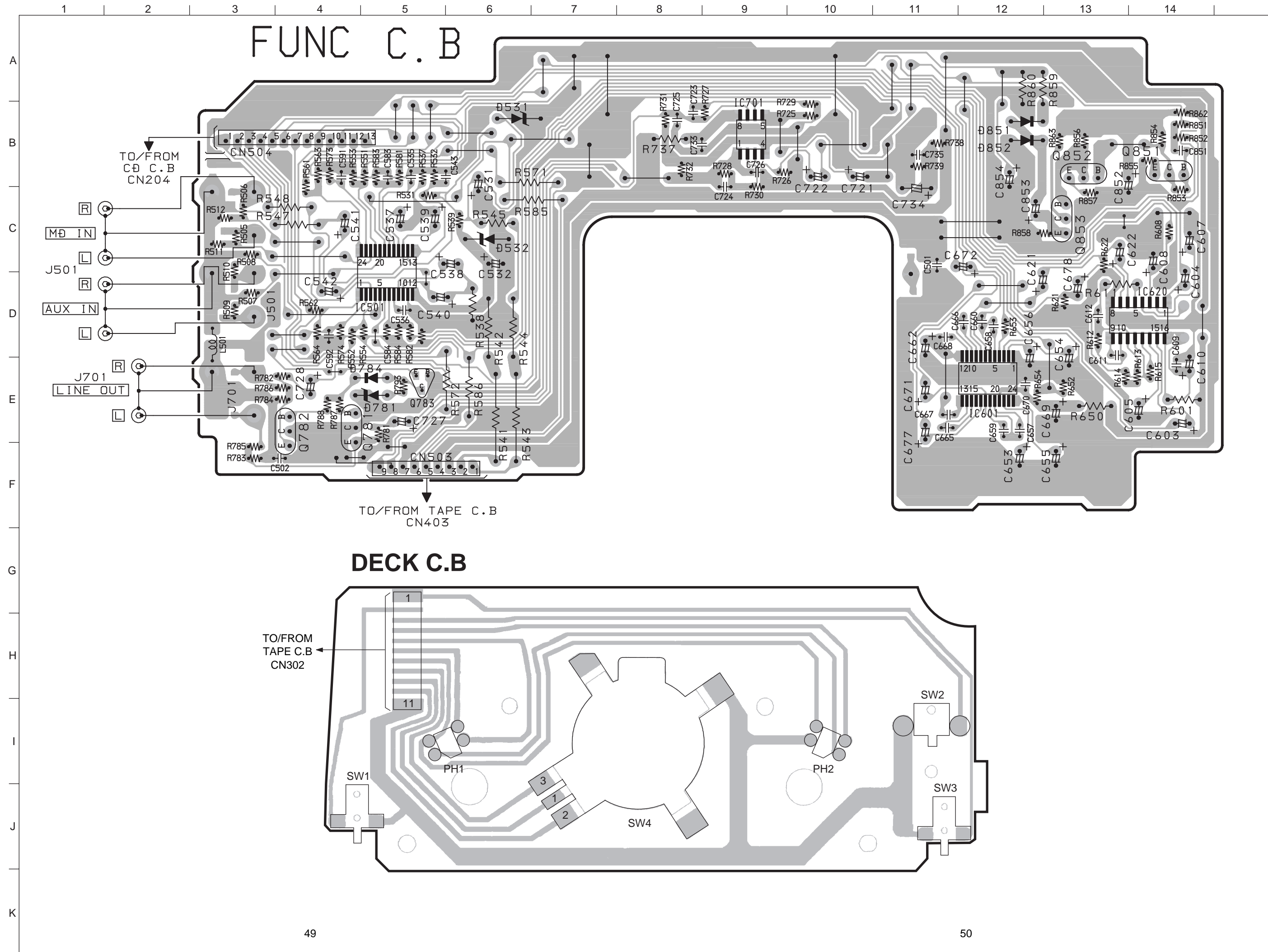

SCHEMATIC DIAGRAM-3 (TAPE/FUNC/KEY)

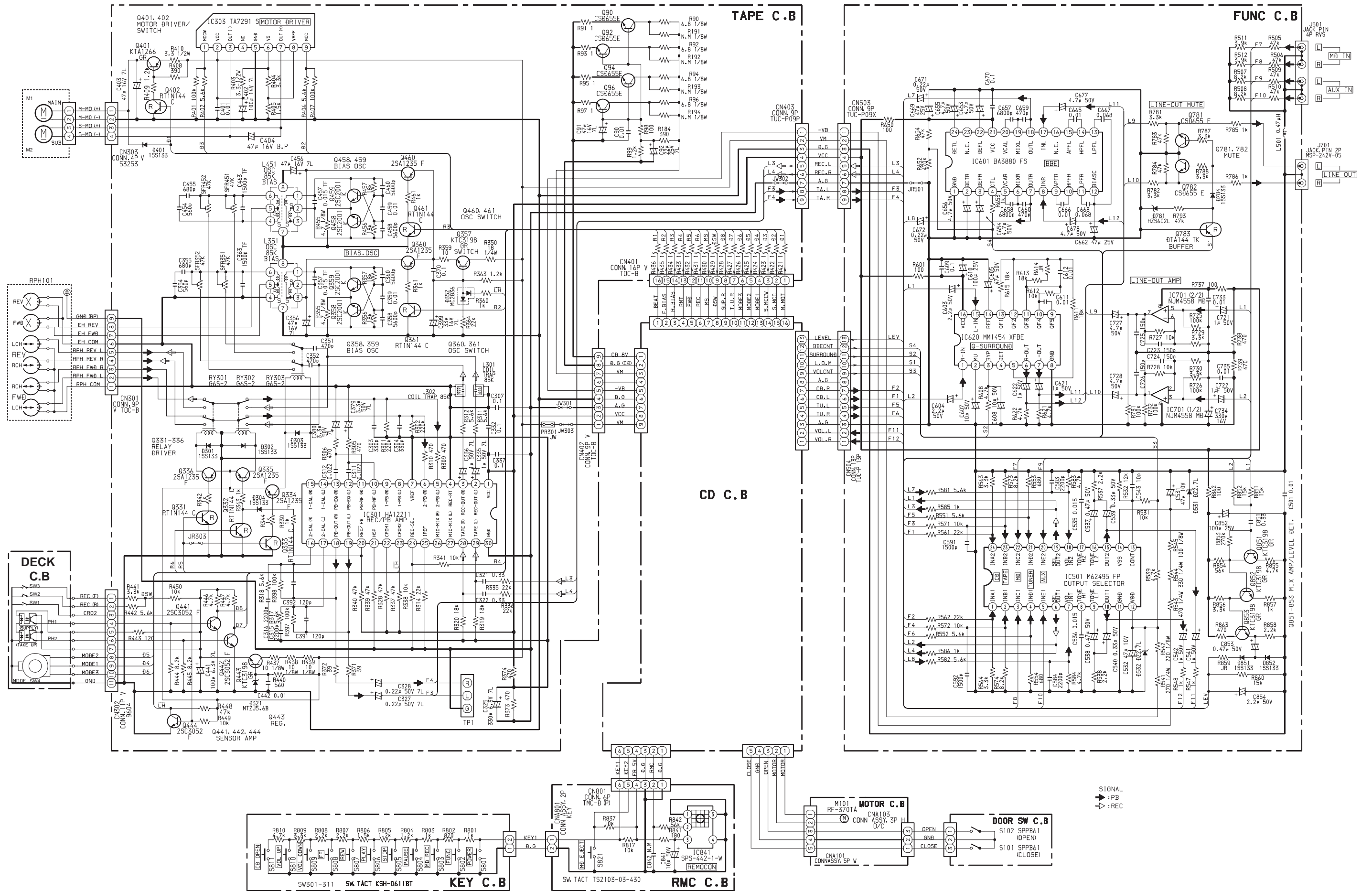

TEST MODE

1. CD Test Mode

1-1. How to Start Up the CD Test Mode

While pressing the “CD OPEN/CLOSE” button, connect the AC plug to the power outlet.
When the CD test mode is started up, When the CD test mode starts up, all displays turn on.

Note: When the PANEL, TOP has been removed for each CHAS, GEAR, be sure to short pin-4 and pin-5 of the connector CN3 on the CD board in order to recognize that the CD lid is closed.

1-2. Releasing the CD Test Mode

Remove the shorting between pin-4 and pin-5 of the connector CN3 on the CD board to return to the original setup.
Then press the POWER button or the FUNCTION button, or remove the AC plug from the power outlet to release the CD test mode.

1-3. Function Description of the Test Mode

MODE	Operation	Indication on display	Function	Contents
Start mode	Starting up the test mode	CD TEST		
Search mode	■	CD	Continuous focus searching. The pickup lens repeats the full-swing up-down motion * Note	Check APC circuit. Laser current measurement. Focus error waveform check.
Play mode	▶	Track No. and playing time are displayed	Normal playback. When the TOC reading is not possible, the same movement as in the search mode.	Focus servo. Tracking servo. CLV servo. Sled servo.
Traverse mode		Track No. and playing time flash	Playback PAUSE mode	Tracking servo OFF.
Sled mode	▶▶ ◀◀	CD TEST	The pickup moves to the innermost track The pickup moves to the outermost track	Sled servo. Check operation of the mechanism.

Note: If the focus search operation is continued for 10 minutes or longer, heating of the driver IC is accumulated to trigger the protection circuit that will stop operation of the CD system. Turn off the main power and re-start operation about 10 minutes later.

ELECTRICAL ADJUSTMENT

CD C.B

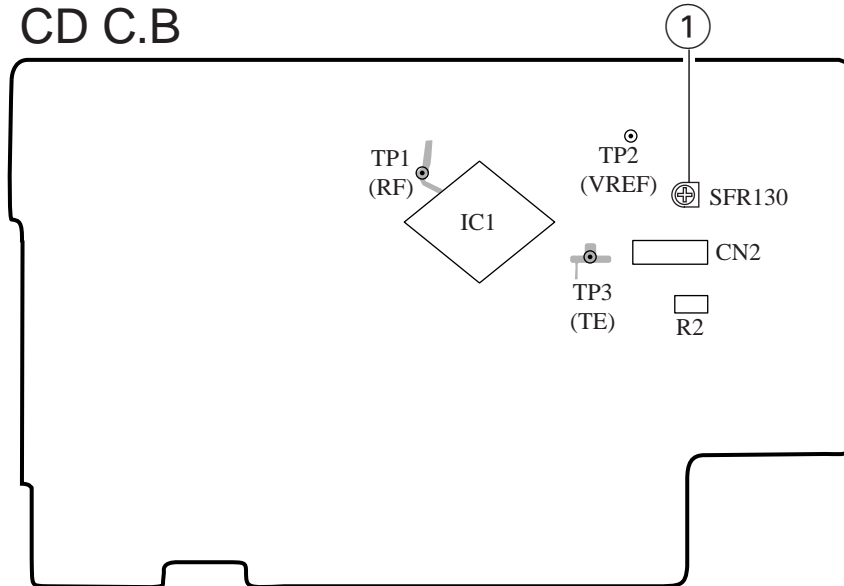

< CD SECTION >

- Note:
- Connect a probe (10: 1) of the oscilloscope test point for adjustment.
 - Connect ground (⊖) terminal of oscilloscope probe to TP3 (VREF) for all adjustment.

1. Focus Bias Adjustment

Make the focus bias adjustment when replacing and repairing the optical block.

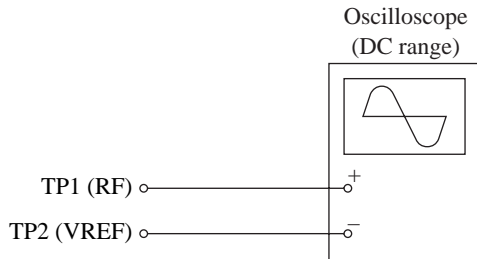

- 1) Connect an oscilloscope to test points TP1 (RF) and TP2 (VREF).
- 2) Turn on the power switch.
- 3) Insert test disc TCD-782 (YEDS-18) and play back the second program.
- 4) Adjust SFR103 so that RF signal of the test point TP1 (RF) is MAX and CLEARREST.

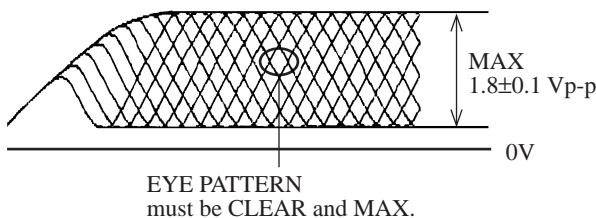

VOLT/DIV: 0.5V
TIME/DIV: 0.5μS

2. Tracking Balance Check

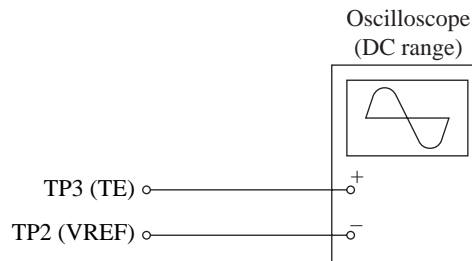

- 1) Connect an oscilloscope to test points TP3 (TE) and TP2 (VREF).
- 2) Start up the CD test mode.
- 3) Insert the test disc TCD-782 (YEDS-18) and enter the traverse mode of the CD test mode.
- 4) Confirm that the traverse waveform on an oscilloscope is vertically symmetrical as shown in the figure below.
- 5) After confirming the waveform, release the CD test mode.

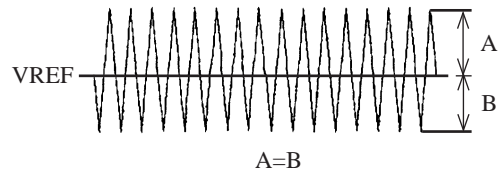

VOLT/DIV: 20mV
TIME/DIV: 1mS

3. Laser Current Check

The current of the laser signal can be checked with the voltages on both sides of R2 (voltage across 10Ω). The difference for the specified value shown on the label must be within ± 6.0mA.

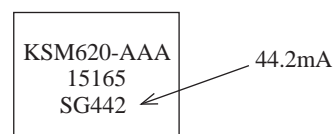

$$\text{Laser current } I_{op} = \frac{\text{Voltage across R2}}{10\Omega}$$

TAPE C.B

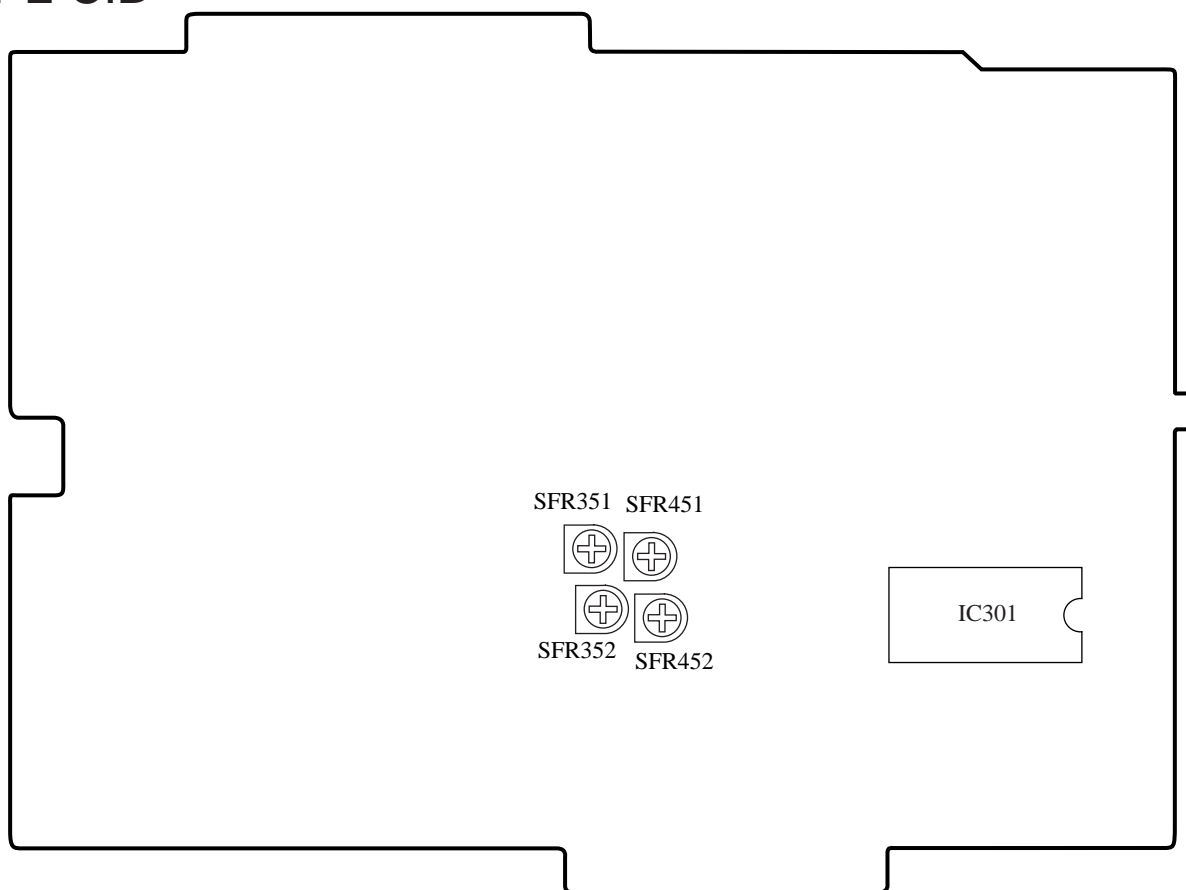

< DECK SECTION >

1. Record/Playback Frequency Response Characteristics Adjustment

Adjustment conditions

- Settings:
- Test tape: TTA-602
 - Test point: LINE OUT (J701)
 - Input signal: 1kHz/10kHz, AUX IN (J501)
 - Adjustment locations: FORWARD direction SFR351(Lch), SFR352 (Rch)
 - Adjustment locations: REVERSE direction SFR451 (Lch), SFR452 (Rch)

* Adjustment can be performed from the bottom of the cabinet.

- Method:
- 1) Input the 1kHz signal and adjust the input signal level for -20 dB.
 - 2) Set the XR-M88 into the record mode and record the 1kHz and 10kHz signals alternately.
 - 3) Play back the segment that is recorded in step 2) and adjust SFR351 and SFR352 so that both the 1kHz and 10kHz signals have the same level within 0 dB +3/-4dB.
 - 4) Perform the same adjustment by adjusting SFR451 and SFR452 in the REVERSE mode in the same way.

PRACTICAL SERVICE FIGURE

< TAPE SECTION >

Tape speed:	3000Hz±60Hz
Wow & Flutter: (W.R.M.S)	Less than 0.21%
Distortion (REC/PB):	Less than 2.5%
Noise level (PB):	Less than 3.5mV (DOLBY OFF, NORM)
Test tape:	NORMAL TTA-602

IC DESCRIPTION

IC, LC866560W-5M02FD

Pin No.	Pin Name	I/O	Description
1	O-MACMD	O	Command output to slave microprocessor.
2	I-SCMD	I	Command input from slave microprocessor.
3	O-ARDY	O	Serial data send/receive preparation completion output for MD UNIT control. (TAPE REC MUTE output).
4	O-SREQ	O	Serial data transfer request for MD UNIT control. (FWD/RWD switching output during TAPE PLAY/REC).
5	I-MREQ	I	Serial data transfer request for MD UNIT control. (REC/PB switching output).
6	O-SURROUND	O	QSURROUND ON/OFF output.
7	O-SRST	O	Reset signal output to slave microprocessor.
8	O-VOLCTL	O	Connected to VOL/P.EQ IC M62439SP pin-⑪ CONT.
9	P36	O	NC.
10	O-COIN	O	Connected to CD DSP LC78622E pin-56 COIN and CD ASP LA9240M pin-52 DAT.
11	O-CKSFT	O	Clock shift output. "L" at clock shift.
12	RST	I	Microprocessor reset.
13	I-DRF	I	Connected to CD ASP LA9240M pin-54 DRF.
14	I-SQOUT	I	Connected to CD DSP LC78622E pin-55 SQOUT.
15	VSS1	—	GND.
16	CF1	I	5.76 MHz. Connected to oscillator.
17	CF2	O	
18	VDD1	—	Microprocessor power supply. (μ-com 5V).
19	I-HOLD	I	Hold state detection. (A/D).
20, 21	I-KEY1, I-KEY2	I	KEY AD data input.
22	AN3	I	DECA MECA state detection input. (AD).
23	AN4	I	TAPE MUSIC SENSOR input. (A/D).
24	I-CDDSW	I	CD DOOR OPEN/CLOSE state detection input. (AD).
25	I-SPE	I	Spare level detection. (A/D).
26	P87	I	NC.
27	I-WRQ	I	Connected to CD DSP LC78622E pin-53 WRQ.
28	P72	I	NC.
29	I-RMC	I	Remote control signal input.
30-45	T0-T15	—	NC.
46	VDD3	—	Microprocessor power supply. (μ-com 5V).
47-49	MODE1-MODE3	I	DECK MECA state detection input.
50	T.U.R	I	Rotation detection of TAKE UP REEL of DECK MECA.
51	VP	—	Connected to negative polarity power supply -VFL for FL.
52	I-SUP.R	I	Rotation detection of TAKE UP REEL of DECK MECA.
53-55	PC5-PC7	I	NC.
56	I-AMST	I	INITIAL DIODE MATRIX input.
57	I-AM10K	I	
58	I-LW	I	
59	I-SW	I	

Pin No.	Pin Name	I/O	Description
60	I-OIRT	I	INITIAL DIODE MATRIX input.
61	I-RDS	I	
62	I-BBE	I	
63	I-DOLBY	I	
64	I-TAPE/MD	I	
65	I-DEMO	I	
66-71	PE2-PE7	I	NC.
72	VDD4	—	Microprocessor power supply. (μ -com 5V).
73	PF0	O	DECK MECA MAIN MOTOR control output.
74, 75	PF1, PF2	O	DECK MECA SUB control output.
76, 77	PF3, PF4	—	NC.
78	I-DOOR DET	I	Over-current detection input to the CD DOOR MOTOR.
79, 80	PF6, PF7	—	NC.
81	O-CDDOPEN	O	CD DOOR OPEN control output.
82	O-CDDCLOSE	O	CD DOOR CLOSE control output.
83, 84	PG2, PG3	—	NC.
85	O-BBEA	O	BBE LEVEL switching output.
86	O-BBEB	O	
87	O-CD	O	Power supply control output of CD block.
88	O-MDRST	O	MD UNIT 7ZG-9A reset signal output.
89	VSS2	—	GND.
90	VDD2	—	Microprocessor power supply. (μ -com 5V).
91	O-RWC	O	Connected to CD DSP LC78622E pin-59 RWC and CD ASP LA9240M pin-53 CF.
92	O-CQCK	O	Connected to CD DSP LC78622E pin-57 CQCK and CD ASP LA9240M pin-51 CL.
93	O-L.O.M	O	LINE OUT MUTE output.
94	P07	—	NC.
95	O-SIN	O	Serial data output for MD UNIT control.
96	I-SOUT	I	Serial data input for MD UNIT control.(FWD REC BIAS control output).
97	I-ACLK	I	Serial clock input for MD UNIT control. (RWD REC BIAS control output).
98	O-MASO	O	Serial data output to slave microprocessor.
99	I-MASI	I	Serial data input from slave microprocessor.
100	O-MACLK	O	Transfer clock output to slave microprocessor.

IC, LA9241ML

Pin No.	Pin Name	I/O	Description
1	FIN2	I	Pin to which external pickup photo diode is connected. RF signal is created by adding with the FIN1 pin signal. FE signal is created by subtracting from the FIN1 pin signal.
2	FIN1	I	Pin to which external pickup photo diode is connected.
3	E	I	Pin to which external pickup photo diode is connected. TE signal is created by subtracting from the F pin signal.
4	F	I	Pin to which external pickup photo diode is connected.
5	TB	I	DC component of the TE signal is input.
6	TE-	I	Pin to which external resistor setting the TE signal gain is connected between the TE pin.
7	TE	O	TE signal output pin.
8	TESI	I	TES "Track Error Sense" comparator input pin. TE signal is passed through a band-pass filter then input.
9	SCI	I	Shock detection signal input pin.
10	TH	I	Tracking gain time constant setting pin.
11	TA	O	TA amplifier output pin.
12	TD-	I	Pin to which external tracking phase compensation constants are connected between the TD and VR pins.
13	TD	I	Tracking phase compensation setting pin.
14	JP	I	Tracking jump signal (kick pulse) amplitude setting pin.
15	TO	O	Tracking control signal output pin.
16	FD	O	Focusing control signal output pin.
17	FD-	I	Pin to which external focusing phase compensation constants are connected between the FD and FA pins.
18	FA	I	Pin to which external focusing phase compensation constants are connected between the FD- and FA- pins.
19	FA-	I	Pin to which external focusing phase compensation constants are connected between the FA and FE pins.
20	FE	O	FE signal output pin.
21	FE-	I	Pin to which external FE signal gain setting resistor is connected between the FE pin.
22	AGND	—	Analog signal GND.
23	NC	—	No connection.
24	SP	O	Single ended output of the CV+ and CV- pin input signal.
25	SPG	I	Pin to which external spindle gain setting resistor in 12 cm mode is connected.
26	SP-	I	Pin to which external spindle phase compensation constants are connected together with SPD pin.
27	SPD	O	Spindle control signal output pin.
28	SLEQ	I	Pin to which external sled phase compensation constants are connected.
29	SLD	O	Sled control signal output pin.
30, 31	SL-, SL+	I	Sled advance signal input pin from microprocessor.
32, 33	JP-, JP+	I	Tracking jump signal input pin from DSP.
34	TGL	I	Tracking gain control signal input from DSP. Low gain when TGL = H.
35	TOFF	I	Tracking off control signal input pin from DSP. Off when TOFF = H.

Pin No.	Pin Name	I/O	Description
36	TES	O	Pin from which TES signal is output to DSP.
37	HFL	O	“High Frequency Level” is used to judge whether the main beam position is on top of bit or on top of mirror.
38	SLOF	I	Sled servo off control input pin.
39, 40	CV-, CV+	I	CLV error signal input pin from DSP.
41	RFSM	O	RF output pin.
42	RFS-	I	RF gain setting and EFM signal 3T compensation constant setting pin together with RFSM pin.
43	SLC	O	“Slice Level Control” is the output pin which controls the RF signal data slice level by DSP.
44	SLI	I	Input pin which control the data slice level by the DSP.
45	DGND	—	Digital system GND.
46	FSC	O	Output pin to which external focus search smoothing capacitor is connected.
47	TBC	I	“Tracking Balance Control” EF balance variable range setting pin.
48	NC	—	No connection.
49	DEF	O	Disc defect detector output pin.
50	CLK	I	Reference clock input pin. 4.23 MHz of the DSP is input.
51	CL	I	Microprocessor command clock input pin.
52	DAT	I	Microprocessor command data input pin.
53	CE	I	Microprocessor command chip enable input pin.
54	DRF	O	“Detect RF” RF level detector output.
55	FSS	I	“Focus Search Select” focus search mode (\pm search/+ search) select pin.
56	VCC2	—	Servo system and digital system Vcc pin.
57	REFI	—	Pin to which external bypass capacitor for reference voltage is connected.
58	VR	O	Reference voltage output pin.
59	LF2	I	Disc defect detector time constant setting pin.
60	PH1	I	Pin to which external capacitor for RF signal peak holding is connected.
61	BH1	I	Pin to which external capacitor for RF signal bottom holding is connected.
62	LDD	O	APC circuit output pin.
63	LDS	I	APC circuit input pin.
64	VCC1	—	RF system Vcc pin.

IC, LC78622ED

Pin No.	Pin Name	I/O	Description	
1	DEFI	I	Defect sense signal (DEF) input pin. (Connect to 0V when not used).	
2	TAI	I	For PLL.	Test signal input pin with built-in pull-down resistor. Be sure to connect to 0V.
3	PDO	O		Phase comparator output pin to control external VCO.
4	VVSS	—		GND pin for built-in VCO. Be sure to connect to 0V.
5	ISET	I		Pin to which external resistor adjusting the PDO output current.
6	VVDD	—		Power supply pin for built-in VCO.
7	FR	I		Pin for VCO frequency range adjustment.
8	VSS	—	Digital system GND. Be sure to connect to 0V.	
9	EFMO	O	For slice level control.	EFM signal output pin.
10	EFMIN	I		EFM signal input pin.
11	TEST2	I	Test signal input pin with built-in pull-down resistor. Be sure to connect to 0V.	
12, 13	CLV+, CLV-	O	Disc motor control output. Three level output is possible using command.	
14	V/P	O	Rough servo or phase control automatic selection monitoring output pin. Rough servo at H. Phase servo at L.	
15	HFL	I	Track detect signal input pin. Schmidt input.	
16	TES	I	Tracking error signal input pin. Schmidt input.	
17	TOFF	O	Tracking OFF output pin.	
18	TGL	O	Tracking gain selection output pin. Gain boost at L.	
19, 20	JP+, JP-	O	Track jump control signal output pin. Three level output is possible using command.	
21	PCK	O	EFM data playback clock monitoring pin 4.3218 MHz when phase is locked in.	
22	FSEQ	O	Sync signal detection output pin. H when the sync signal which is detected from EFM signal and thesync signal which is internally generated agree.	
23	VDD	—	Digital system power supply pin.	
24-28	SL+ - PUIN	I/O	General purpose input/output pin 1 to 5.	The pin is controlled by the serial data command from microprocessor. When the pin is not used, set the pin to the input terminal and connect to 0V, or alternately set the pin to output terminal and leave the pin open.
29	EMPH	O	De-emphasis monitor output pin. De-emphasis disc is being played back at H.	
30	C2F	O	C2 flag output pin.	
31	DOUT	O	DIGITAL OUT output pin. (EIAJ format).	
32, 33	TEST3, TEST4	I	Test signal input pin with built-in pull-down resistor. Be sure to connect to 0V.	
34	N.C.	—	Not used. Set the pin to open.	
35	MUTEL	O	L-channel 1-bit DAC.	L-channel mute output pin.
36	LVDD	—		L-channel power supply pin.
37	LCHO	O		L-channel output pin.
38	LVSS	—		L-channel GND. Be sure to connect to 0V.
39	RVSS	—	R-channel 1-bit DAC.	R-channel GND. Be sure to connect to 0V.
40	RCHO	O		R-channel output pin.
41	RVDD	—		R-channel power supply pin.
42	MUTER	O		R-channel mute output pin.

Pin No.	Pin Name	I/O	Description
43	XVDD	—	Crystal oscillator power supply pin.
44	XOUT	O	Pin to which external 16.9344 MHz crystal oscillator is connected.
45	XIN	I	
46	XVSS	—	Crystal oscillator GND pin. Be sure to connect to 0V.
47	SBSY	O	Subcode block sync signal output pin.
48	EFLG	O	C1, C2, single and dual correction monitoring pin.
49	PW	O	Subcode P, Q, R, S, T, U and W output pin.
50	SFSY	O	Subcode frame sync signal output pin. Falls down when subcode enters standby.
51	SBCK	I	Subcode read clock input pin. Schmidt input. (Be sure to connected to 0V when not in use.)
52	FSX	O	Pin outputting the 7.35 kHz sync signal which is generated by dividing frequency of crystal oscillator.
53	WRQ	O	Subcode Q output standby output pin.
54	RWC	I	Read/write control input pin. Schmidt input.
55	SQOUT	O	Subcode Q output pin.
56	COIN	I	Command input pin from microprocessor.
57	\overline{CQCK}	I	Command input read clock or subcode read input clock from SQOUT pin
58	\overline{RES}	I	LC78622 reset input pin. Set this pin to L once when the main power is turned on.
59	TST11	O	Test signal output pin. Use this pin as open (normally L output).
60	16M	O	16.9344 MHz output pin.
61	4.2M	O	4.2336 MHz output pin.
62	TEST5	I	Test signal input pin with built-in pull-down resistor. Be sure to connect to 0V.
63	\overline{CS}	I	Chip select signal input pin with built-in pull-down resistor. Be sure to connect to 0V while it is not controlling.
64	TEST1	I	Test signal input pin without built-in pull-down resistor. Be sure to connect to 0V.

Note: The same potential must be applied to the respective power supply terminals. (VDD, VVDD, LVDD, RVDD, XVDD)

IC BLOCK DIAGRAM
IC, BA5936

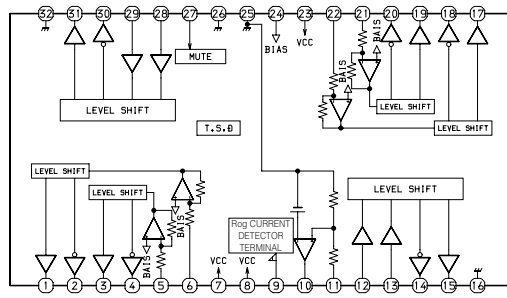

IC, M62495FP

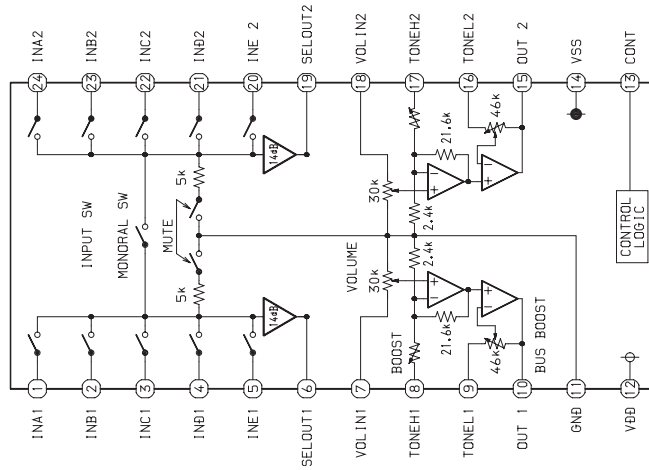

IC, BA3880FS

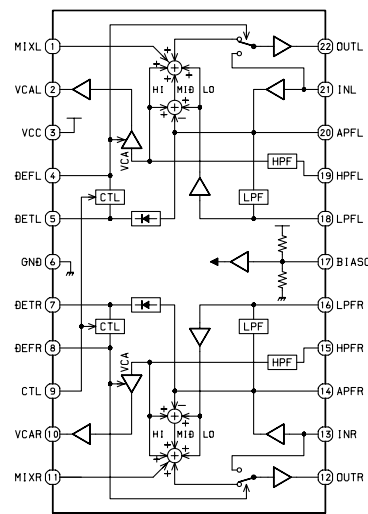

IC, MM1454XFBE

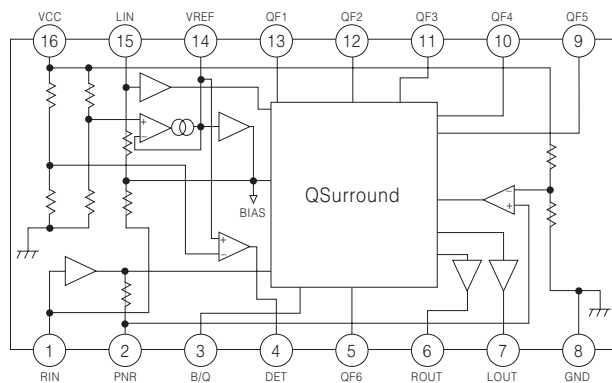

MECHANICAL EXPLODED VIEW 1/1

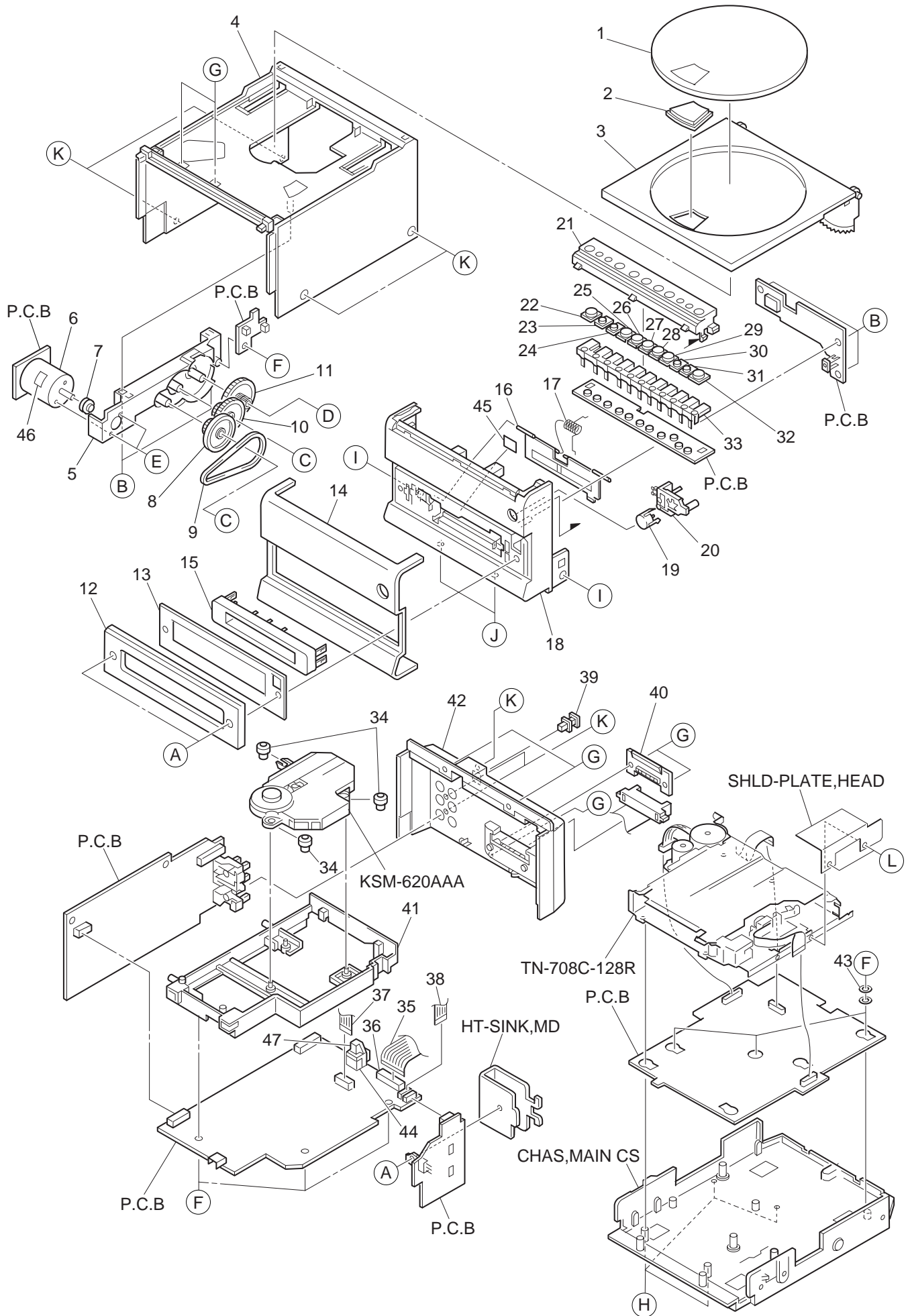

MECHANICAL PARTS LIST 1/1

DESCRIPTIONで判断できない物は "REFERENCE NAME LIST" を参照してください。
 If can't understand for Description please kindly refer to "REFERENCE NAME LIST".

REF. NO	PART NO.	KANRI NO.	DESCRIPTION	REF. NO	PART NO.	KANRI NO.	DESCRIPTION
1	8Z-CL1-014-010		PANEL, CD	31	8Z-CL1-025-010		CAP, UP
2	8Z-CL1-012-010		WINDOW, CD	32	8Z-CL1-026-010		CAP, OPEN
3	8Z-CL1-004-010		CABI, TOP FD	33	8Z-CL1-206-010		BTN, CONT
4	8Z-CL1-007-110		BOX, CD	34	88-HV1-207-010		DMPR, MECHA
5	8Z-CL1-205-210		HLDR, GEAR	35	8Z-CL1-653-110		F-CABLE, 19P 1.5 FG
6	87-A91-069-010		MOT, RF-370CA15370	36	87-A90-878-010		HLDR, WIRE 19P 1.5 51016
7	8Z-CL1-210-010		PULLEY, MOTOR	37	8Z-CLB-653-010		FF-CABLE, 16P 1.0 150MM
8	8Z-CL1-211-010		PULLEY, CD	38	8Z-CLB-651-010		FF-CABLE, 9P 1.0 150MM
9	8Z-CL1-212-010		BELT, CD	39	84-ZG1-245-210		CAP, OPTICAL
10	8Z-CL1-209-010		GEAR, B	40	8Z-CL1-029-010		LID, CORD
11	8Z-CL1-208-010		GEAR, A	41	8Z-CL1-202-110		CHAS, CD
12	8Z-CL1-011-110		WINDOW, MD	42	8Z-CLB-076-010		PANEL, REAR FD CS HC
13	8Z-CL1-033-010		PLATE, WINDOW FD	43	8Z-CLB-203-010		W, 3.2-12-0.7
14	8Z-CLB-012-010		PANEL, FD CS	44	84-ZG1-261-010		LID, OPTICAL
15	8Z-CLB-002-010		PANEL, CS	45	8Z-CLB-220-010		COVER, SCREW
16	8Z-CLB-004-010		PANEL, FLAP CS	46	87-CE1-214-010		FELT 10-40
17	8Z-CLB-005-010		SPR-T, FLAP	47	84-ZG1-244-310		CABI, OPTICAL
18	8Z-CLB-001-110		CABI, FR CS	A	8Z-CL1-034-010		S-SCREW, ZCL1
19	8Z-CL1-028-010		CAP, EJECT	B	87-067-703-010		TAPPING SCREW, BVT2+3-10
20	8Z-CL1-207-010		BTN, EJECT	C	87-761-096-410		VFT2+3-10 GLD
21	8Z-CLB-014-010		PANEL, CONT CS	D	87-B10-162-010		VFT2+2-6
22	8Z-CL1-016-010		CAP, POWER	E	87-261-092-410		V+3-4 GLD
23	8Z-CL1-017-010		CAP, FUNC	F	87-067-579-010		TAPPING SCREW, BVT2+3-8
24	8Z-CL1-018-010		CAP, REC	G	87-B10-269-010		UT2+3-12 W/O CR
25	8Z-CL1-019-010		CAP, PAUSE	H	87-261-101-410		V+3-18
26	8Z-CL1-020-010		CAP, STOP	I	87-721-095-410		QT2+3-8GLD W/O SLOT
27	8Z-CLB-003-010		CAP, PLAY CS	J	87-067-761-010		TAPPING SCREW, BVT2+3-10
28	8Z-CL1-022-010		CAP, REW	K	87-744-095-410		UT2+3-8CR
29	8Z-CL1-023-010		CAP, FF	L	87-067-421-010		VTT+2-4
30	8Z-CL1-024-010		CAP, DOWN				

COLOR NAME TABLE

Basic color symbol	Color	Basic color symbol	Color	Basic color symbol	Color
B	Black	C	Cream	D	Orange
G	Green	H	Gray	L	Blue
LT	Transparent Blue	N	Gold	P	Pink
R	Red	S	Silver	ST	Titan Silver
T	Brown	V	Violet	W	White
WT	Transparent White	Y	Yellow	YT	Transparent Yellow
LM	Metallic Blue	LL	Light Blue	GT	Transparent Green
LD	Dark Blue	DT	Transparent Orange		

TAPE MECHANISM EXPLODED VIEW 1/1

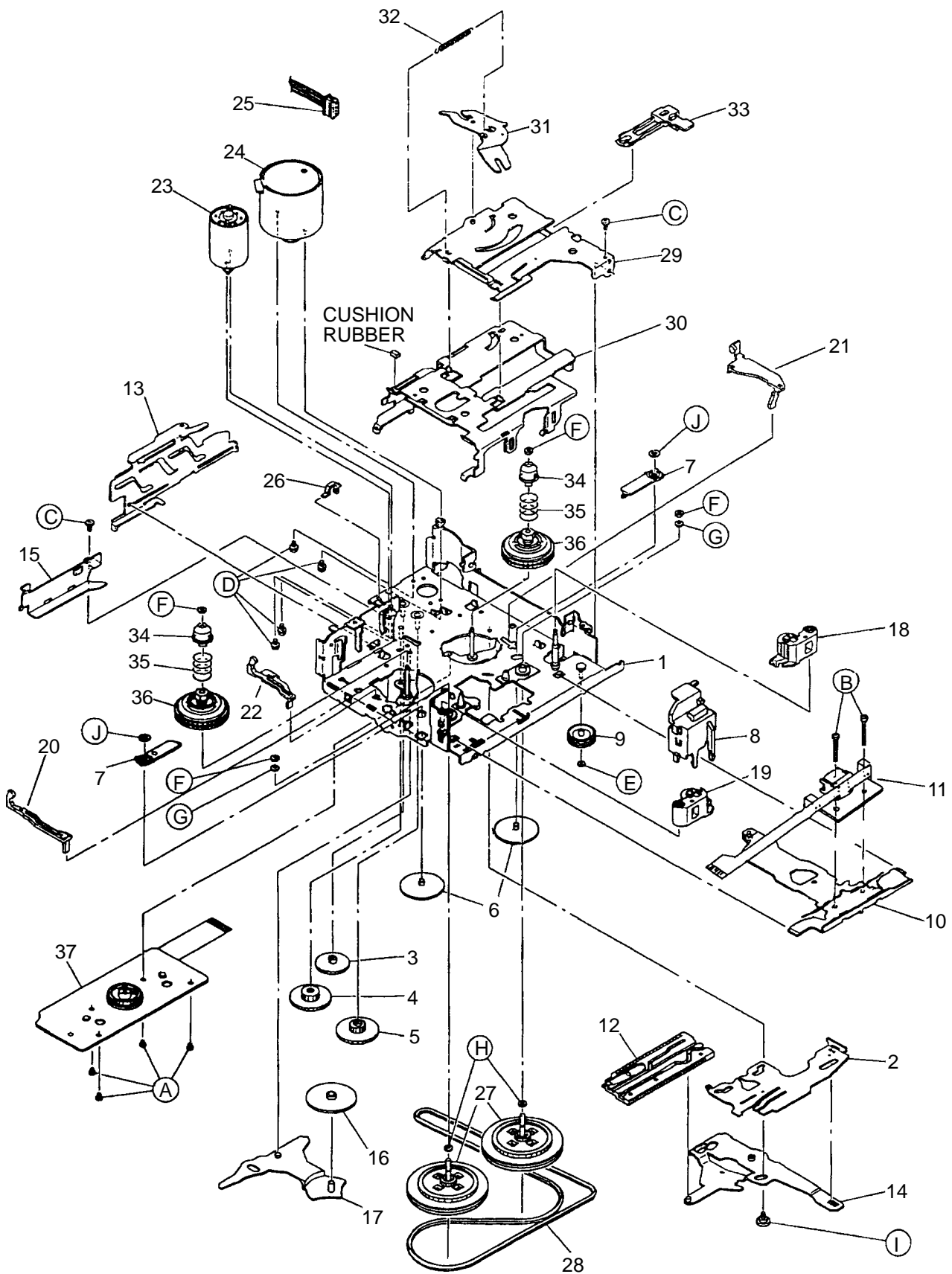

TAPE MECHANISM PARTS LIST 1/1

DESCRIPTIONで判断できない物は "REFERENCE NAME LIST" を参照してください。
 If can't understand for Description please kindly refer to "REFERENCE NAME LIST".

REF.NO	PART NO.	KANRI NO.	DESCRIPTION	REF.NO	PART NO.	KANRI NO.	DESCRIPTION
1	S1-970-015-070		CHASSIS RIVET ASY	26	S1-950-140-030		WIRE CLUMPER
2	S1-970-020-010		MAIN PLATE	27	S1-970-113-010		FL CAPSTAN ASSY
3	S1-970-020-020		B GEAR	28	S1-970-110-060		MAIN BELT(G)
4	S1-970-020-030		C GEAR	29	S1-970-120-010		CASE LIFTER B
5	S1-970-020-040		D GEAR	30	S1-970-120-160		CASSETTE CASE R
6	S1-970-020-120		P GEAR W	31	S1-970-120-040		P.S ACTUATOR PLATE
7	S1-970-020-060		P G PLATE	32	S1-970-120-050		P.S SPRING
8	S1-970-020-070		GUIDE BKT	33	S1-970-120-030		PACK SLIDER
9	S1-950-100-020		MIDDLE PULLEY	34	S1-950-080-220		RELL CAP
10	S1-970-033-030		HEAD PANEL ASSY	35	S1-970-080-120		REEL WING SPRING
11	S6-201-050-020		RPF AC-5544BM-5949	36	S1-970-083-020		REEL ASSY(K)
12	S1-970-043-010		O P PLATE ASSY	37	S1-970-133-070		REEL PWB ASSY
13	S1-970-045-040		EJECT LEVER RIVET ASSY	A	87-267-545-310		CAMERA TAPPING SCREW S 2.0-2.5
14	S1-970-045-020		S.B PLATE RIVET ASSY	B	87-263-033-010		SCREW,2.0-4.0
15	S1-970-047-070		O.P PLATE HOLDER	C	87-351-547-410		S TAPING SCREW(FOR CAMERA)M2-3
16	S1-970-060-020		FR GEAR	D	87-B10-255-010		TAMS SCREW M2-3
17	S1-970-060-010		FR PLATE	E	86-544-439-010		P.WASHER(CUT)0.85-2.8-0.25
18	S1-970-073-030		PINCH ROLLER ARM(F) ASSY	F	S9-W06-500-400		P.WASHER(CUT)1.55-3.5-0.5
19	S1-970-073-040		PINCH ROLLER ARM(R)ASSY	G	87-081-978-010		P.WASHER 2.1-3.5-0.2
20	S1-970-020-130		REC SENSOR F	H	87-067-529-010		P.WASHER 2.1-3.5-0.35
21	S1-970-020-140		REC SENSOR R	I	S1-821-120-230		PK COLLAR SCREW A
22	S1-970-020-150		CR DETECTIVE PLATE HOLDER	J	S9-W06-400-700		HLW WASHER(CUT)2.1-4.0-0.35
23	S1-970-093-010		SUB MOTOR ASSY				
24	S1-970-103-010		MAIN MOTOR ASSY				
25	S1-970-100-020		M CONNECTOR ASSY				

CD MECHANISM EXPLODED VIEW 1/1

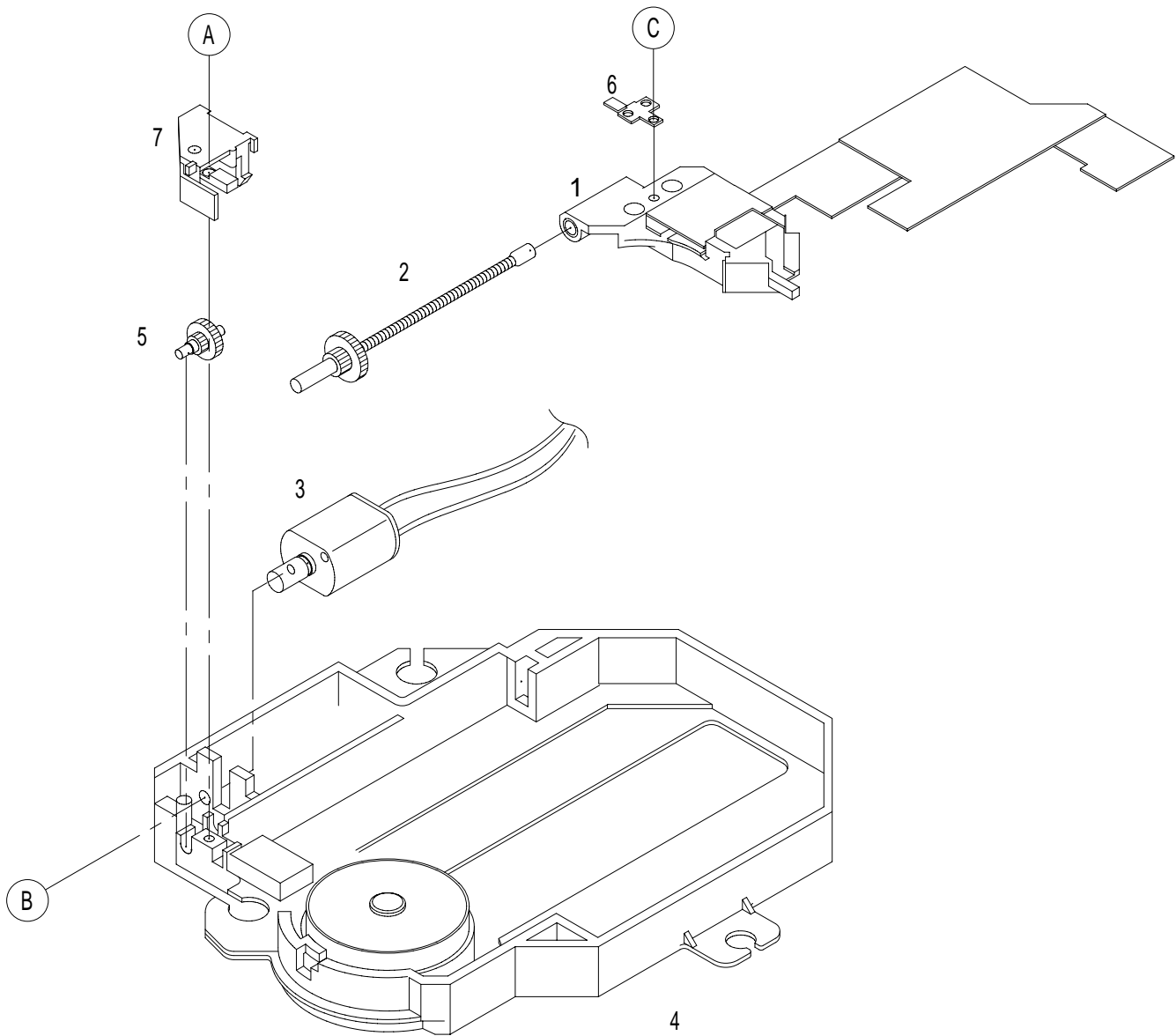

CD MECHANISM PARTS LIST 1/1

DESCRIPTIONで判断できない物は "REFERENCE NAME LIST" を参照してください。
If can't understand for Description please kindly refer to "REFERENCE NAME LIST".

REF.NO	PART NO.	KANRI NO.	DESCRIPTION
1	98-820-063-030		KSS-620A(RP)
2	9X-264-638-910		SLED SCREW ASSY
3	9A-491-219-9A0		SLED MOTOR ASSY
4	9X-264-648-210		MD ASSY
5	92-627-751-020		GEAR BN
6	92-646-914-010		LACK SPRING
7	92-646-913-010		HOLDER
A	92-646-352-010		TAPPING SCREW B2-8
B	92-627-668-010		SCREW M2-2.5
C	92-646-358-110		TAPPING SCREW B1.7-4

MODEL NO. SX-LM200

SPEAKER DISASSEMBLY INSTRUCTIONS

Type.1

Insert a flat-bladed screwdriver into the position indicated by the arrows and remove the panel. Remove the screws of each speaker unit and then remove the speaker units.

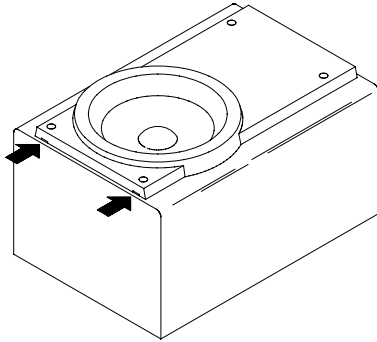

Type.2

Remove the grill frame and four pieces of rubber caps by pulling out with a flat-bladed screwdriver. Remove the screws from hold where installed rubber caps. Insert a flat-bladed screwdriver into the position indicated by the arrows and remove the panel. Remove the screws of each speaker unit and then remove the speaker units.

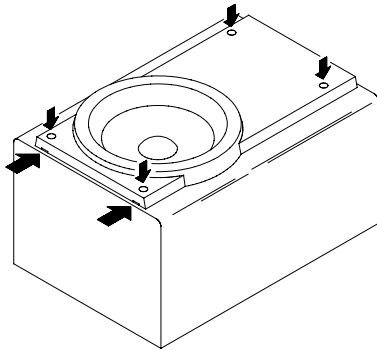

Type.3

Insert a flat-bladed screwdriver into the position indicated by the arrows and remove the panel. Turn the speaker unit to counter-clockwise direction while inserting a flat-bladed screwdriver into one of the hollows around speaker unit, and then remove the speaker unit. After replacing the speaker unit, install it turning to clockwise direction until "click" sound comes out.

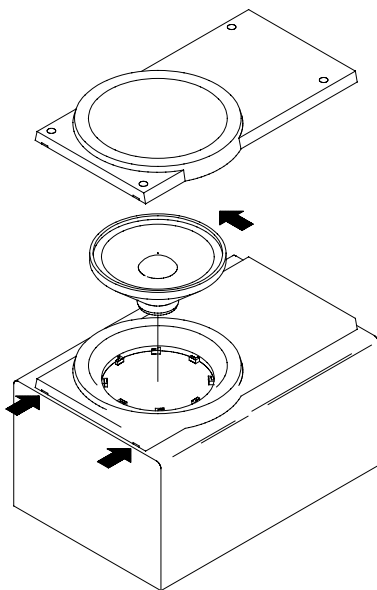

Type.4

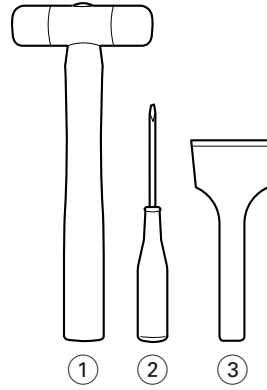

TOOLS

- ① Plastic head hammer
- ② (⊖) flat head screwdriver
- ③ Cut chisel

How to Remove the PANEL, FR

1. Insert the (⊖) flat head screwdriver tip into the gap between the PANEL, FR and the PANEL, SPKR. Tap the head of the (⊖) flat head screwdriver with the plastic hammer head, and create the clearance as shown in Fig-1.
2. Insert the cut chisel in the clearance, and tap the head of the cut chisel with plastic hammer as shown in Fig-2, to remove the PANEL, FR.
3. Place the speaker horizontally. Tap head of the cut chisel with plastic hammer as shown in Fig-3, and remove the PANEL, FR completely.

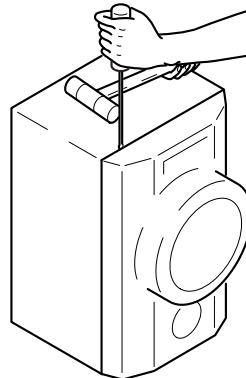

Fig-1

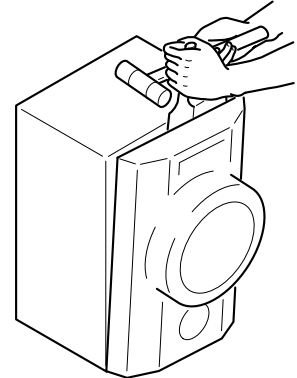

Fig-2

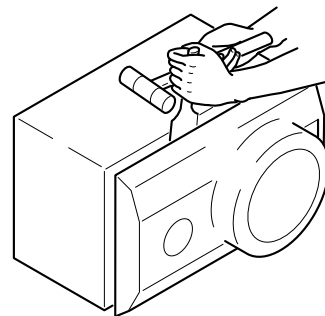

Fig-3

How to Attach the PANEL, FR

Attach the PANEL, FR to the PANEL, SPKR. Tap the four corners of the PANEL, FR with the plastic hammer to fit the PANEL, FR into the PANEL, SPKR completely.

SPEAKER PARTS LIST 1/1

DESCRIPTIONで判断できない物は "REFERENCE NAME LIST" を参照してください。
If can't understand for Description please kindly refer to "REFERENCE NAME LIST".

REF. NO	PART NO.	KANRI NO.	DESCRIPTION
1	8Z-CP1-012-010		CORD, SP
2	8Z-CP1-006-010		GRILLE, FRAME ASSY<YJTN>
2	8Z-CP1-017-010		GRILLE, FRAME ASSY B<YJBN>
3	8Z-CP1-003-010		PANEL, FR<YJTN>
3	8Z-CP1-015-010		PANEL, FR B<YJBN>
4	8Z-CP1-005-010		PANEL, TW<YJTN>
4	8Z-CP1-016-010		PANEL, TW B<YJBN>
5	8Z-CP1-601-010		SPKR, W 100
6	88-CL1-937-010		SPKR, TW 25

