

SERVICE MANUAL

COMPACT DISC STEREO SYSTEM

BASIC CD MECHANISM : 3ZG-3 E13NM

SYSTEM	STEREO TUNER	STEREO INTEGRATED AMPLIFIER	COMPACT DISC PLAYER	STEREO CASSETTE DECK	MINI DISC RECORDER	SPEAKER	REMOTE CONTROLLER
XR-M918	TX-LM918	MX-LM918	DX-LM918	FX-LM918	AM-LM918	SX-LM918	RC-BAT02
XR-M919	TX-LM919	MX-LM919		(OPTIONAL)	(OPTIONAL)		

- This Service Manual is the "Revision Publishing" and replaces "Simple Manual" XR-M919 (EZ), (S/M Code No. 09-014-444-6T1) and XR-M918 (K), (S/M Code No. 09-014-444-6T2).
- If requiring information about FX-LM918, see Service Manual of FX-LM918 (Y), (S/M Code No. 09-015-444-7R1).
- If requiring information about AM-LM918, see Service Manual of AM-LM918 (Y), (S/M Code No. 09-016-446-9R1).

TABLE OF CONTENTS

SPECIFICATIONS	3
PROTECTION OF EYES FROM LASER BEAM DURING SERVICING	4
MODEL NO. TX-LM918 / LM919	
ELECTRICAL MAIN PARTS LIST	5 ~ 7
TRANSISTOR ILLUSTRATION	8
WIRING - 1 (MAIN) <EZ>	9
WIRING - 2 (MAIN) <K>	10
WIRING - 3 (FRONT / CONN / AUX / TAPE - JACK / LED - L / LED - R / LCD - LED) <EZ>	11
WIRING - 4 (FRONT / CONN / AUX / TAPE - JACK / LED - L / LED - R / LCD - LED) <K>	12
SCHEMATIC DIAGRAM - 1 (MAIN / FRONT / CONN / AUX / TAPE - JACK / LED - L / LED - R / LCD - LED)	13
WIRING - 5 (TUNER)	14
SCHEMATIC DIAGRAM - 2 (TUNER)	15
IC BLOCK DIAGRAM	16
LCD DIAGRAM	17
IC DESCRIPTION	18, 19
ADJUSTMENT	20
MECHANICAL EXPLODED VIEW 1 / 1 <EZ>	21
MECHANICAL PARTS LIST 1 / 1 <EZ>	22
MECHANICAL EXPLODED VIEW 1 / 1 <K>	23
MECHANICAL PARTS LIST 1 / 1 <K>	24
MODEL NO. MX-LM918 / LM919	
ELECTRICAL MAIN PARTS LIST	25, 26
TRANSISTOR ILLUSTRATION	27
WIRING - 1 (PWB - AMP / HP)	28
WIRING - 2 (SPK / FRONT / LED - L / LED - R / AC)	29
SCHEMATIC DIAGRAM (PWB - AMP / SPK / FRONT / HP / LED - L / LED - R / AC)	30
MECHANICAL EXPLODED VIEW 1 / 1 <EZ>	31
MECHANICAL PARTS LIST 1 / 1 <EZ>	32
MECHANICAL EXPLODED VIEW 1 / 1 <K>	33
MECHANICAL PARTS LIST 1 / 1 <K>	34
MODEL NO. DX-LM918	
ELECTRICAL MAIN PARTS LIST	35, 36
TRANSISTOR ILLUSTRATION	37
WIRING (MAIN / SUB / FRONT / LED - L / LED - R / CD LOAD / CD DRIVE)	38
SCHEMATIC DIAGRAM (MAIN / SUB / FRONT / LED - L / LED - R / CD LOAD / CD DRIVE)	39
IC BLOCK DIAGRAM	40
IC DESCRIPTION	41 ~ 44
ELECTRICAL MEASUREMENT	45
CD TEST MODE	46
MECHANICAL EXPLODED VIEW 1 / 1	47
MECHANICAL PARTS LIST 1 / 1	48
CD MECHANISM EXPLODED VIEW 1 / 2 <3ZG-3 E13NM>	49
CD MECHANISM PARTS LIST 1 / 2 <3ZG-3 E13NM>	50
CD MECHANISM EXPLODED VIEW 2 / 2 <3ZG-2 E3NM>	51
CD MECHANISM PARTS LIST 2 / 2 <3ZG-2 E3NM>	51
GENERAL SPEAKER DISASSEMBLY INSTRUCTIONS (FOR REFERENCE)	52
SPEAKER PARTS LIST <SX-LM918 (YML, YJMN)>	53
ACCESSORIES / PACKAGE LIST	53

SPECIFICATIONS

<STEREO TUNER TX-LM918 / LM919>

<FM Tuner section>

Tuning range	87.5 MHz to 108 MHz
Usable sensitivity (IHF)	16.8 dBf
Antenna terminal	75 ohms (unbalanced)

<MW Tuner section>

Tuning range	531 kHz to 1602 kHz (9 kHz step) 530 kHz to 1710 kHz (10 kHz step)
Usable sensitivity	350 μ V/m
Antenna	Loop antenna

<LW Tuner section>

Tuning range	144 kHz to 290 kHz
Usable sensitivity	1400 μ V/m
Antenna	Loop antenna

<Input>

AUX IN	500 mV
---------------	--------

<General>

Dimensions (W x H x D)	210 x 82.5 x 248 mm
Weight	1.1 kg

<STEREO INTEGRATED AMPLIFIER MX-LM918 / LM919>

<Amplifier section>

Power output	Rated: 25 W + 25 W (6 ohms, T.H.D. 1 %, 1 kHz / DIN 45500) Reference: 30 W + 30 W (6 ohms, T.H.D. 10 %, 1 kHz / DIN 45324) DIN MUSIC POWER 72 W + 72 W
---------------------	---

<Outputs>

SUPER WOOFER	1.2 V
SPEAKERS	6 ohms or more
PHONES	47 kilohms or more

<General>

Power requirements	230 V AC, 50 Hz
Power consumption	85 W
Power consumption in standby mode	With ECO mode on : 1.7 W With ECO mode off : 12 W
Dimensions (W x H x D)	210 x 82.5 x 286 mm
Weight	3.9 kg

<COMPACT DISC PLAYER DX-LM918>

<Compact disc player section>

Laser	Semiconductor laser ($\lambda = 780$ nm)
D-A converter	1 bit dual
Signal-to-noise ratio	90 dB (1 kHz, 0 dB)
Harmonic distortion	1.05 % (1 kHz, 0 dB)
Wow and flutter	Unmeasurable

<Output>

DIGITAL OUT

<General>

Dimensions (W x H x D)	210 x 82.5 x 243 mm
Weight	1.3 kg

<SPEAKER SYSTEM SX-LM918>

Cabinet type	2 way, bass reflex (magnetic shielded type)
Speakers	Woofer: 130 mm cone type Tweeter: 25 mm dome type
Impedance	6 ohms
Dimensions (W x H x D)	166 x 324 x 232 mm
Weight	3.6 kg

- Design and specifications are subject to change without notice.
- The word "BBE" and the "BBE symbol" are trademarks of BBE Sound, Inc.
Under license from BBE Sound, Inc.

PROTECTION OF EYES FROM LASER BEAM DURING SERVICING

This set employs laser. Therefore, be sure to follow carefully the instructions below when servicing.

WARNING!!

WHEN SERVICING, DO NOT APPROACH THE LASER EXIT WITH THE EYE TOO CLOSELY. IN CASE IT IS NECESSARY TO CONFIRM LASER BEAM EMISSION. BE SURE TO OBSERVE FROM A DISTANCE OF MORE THAN 30cm FROM THE SURFACE OF THE OBJECTIVE LENS ON THE OPTICAL PICK-UP BLOCK.

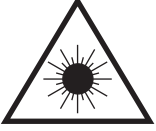

- Caution: Invisible laser radiation when open and interlocks defeated avoid exposure to beam.
- Advarsel: Usynlig laserstråling ved åbning, når sikkerhedsafbrydere er ude af funktion. Undgå udsættelse for stråling.

VAROITUS!

Laiteen Käyttäminen muulla kuin tässä käyttöohjeessa mainitulla tavalla saattaa altistaa käyt-täjän turvallisuusluokan 1 ylittävälle näkymättömälle lasersäteilylle.

WARNING!

Om apparaten används på annat sätt än vad som specificeras i denna bruksanvisning, kan användaren utsättas för osynlig laserstråling, som överskrider gränsen för laserklass 1.

CAUTION

Use of controls or adjustments or performance of procedures other than those specified herein may result in hazardous radiation exposure.

ATTENTION

L'utilisation de commandes, réglages ou procédures autres que ceux spécifiés peut entraîner une dangereuse exposition aux radiations.

ADVARSEL

Usynlig laserstråling ved åbning, når sikkerhedsafbrydere er ude af funktion. Undgå udsættelse for stråling.

This Compact Disc player is classified as a CLASS 1 LASER product.

The CLASS 1 LASER PRODUCT label is located on the rear exterior.

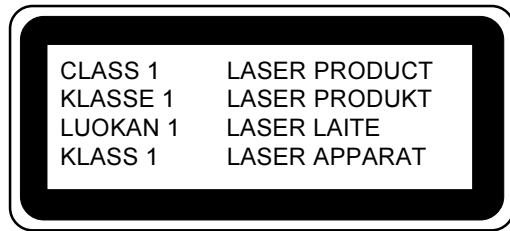

Precaution to replace Optical block

(KSS-213F)

Body or clothes electrostatic potential could ruin laser diode in the optical block. Be sure ground body and workbench, and use care the clothes do not touch the diode.

- 1) After the connection, remove solder shown in right figure.

CD PICK-UP Assy PWB

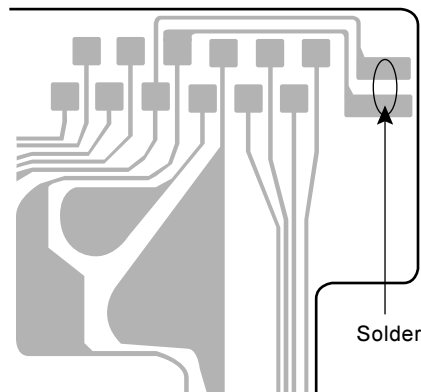

MODEL NO.

TX-LM918 / LM919

ELECTRICAL MAIN PARTS LIST

REF. NO.	PART NO.	KANRI NO.	DESCRIPTION	REF. NO.	PART NO.	KANRI NO.	DESCRIPTION
IC							
	87-A21-022-040		C-IC,BA3880FS	C133	87-010-759-080		C-CAP,U 0.1-25F
	87-A21-103-040		C-IC,MM1454XFBE	C135	87-012-195-080		C-CAP,U 100P-50 J CH<K>
	87-A21-443-040		C-IC,M62495AFP	C201	87-A12-090-080		CAP,E 4.7-50 SMG
	8B-CF1-609-010		C-IC,LC87F65C8A-BCF1<EZ>	C202	87-A12-090-080		CAP,E 4.7-50 SMG
	8B-CF1-610-010		C-IC,LC876596-BCJ1<K>	C203	87-010-785-080		C-CAP,U 0.015-25 KB
	87-A21-380-040		C-IC,PQ20WZ51	C204	87-012-270-080		CAP, U 470P-50
	87-A20-440-040		C-IC,BU1920FS<EZ>	C205	87-012-274-080		CHIP CAP,U 1000P-50B
	87-A21-831-010		IC,SPS-422-1-F1	C206	87-012-286-080		CAP, U 0.01-25
	87-A21-695-010		IC,LA1845L	C207	87-A11-993-080		C-CAP,U 0.056-16 K B
	87-A21-928-010		IC,LC72131D-N	C208	87-A12-066-080		CAP,E 47-16 SMG
TRANSISTOR							
	87-A30-468-080		C-TR,KRC102S-RTK	C209	87-A12-085-080		CAP,E 0.33-50 SMG
	87-A30-196-080		TR,2SC4115SRS	C210	87-A12-086-080		CAP,E 0.47-50 SMG
	89-113-184-080		TR,2SA1318T<EZ>	C211	87-A12-086-080		CAP,E 0.47-50 SMG
	87-A30-490-080		C-TR,KRC107S	C212	87-A12-085-080		CAP,E 0.33-50 SMG
	87-A30-047-080		TR,CSD655E	C213	87-A11-993-080		C-CAP,U 0.056-16 K B
	87-A30-087-080		C-FET,2SK2158	C214	87-012-286-080		C-CAP,U 0.01-25 K B
	87-A30-076-080		C-TR,2SC3052F	C215	87-012-274-080		CHIP CAP,U 1000P-50B
	87-026-610-080		TR,KTC3198GR	C216	87-012-270-080		C-CAP, U 470P-50
	87-A30-269-040		C-FET,2SJ461-T1<EZ>	C217	87-010-785-080		C-CAP,U 0.015-25K B
	89-327-143-080		C-TR,2SC27140	C218	87-A12-066-080		CAP,E 47-16 SMG
	87-A30-489-080		C-TR,KRA107S	C219	87-A12-090-080		CAP,E 4.7-50 SMG
	89-503-602-080		C-FET,2SK360E	C220	87-A12-090-080		CAP,E 4.7-50 SMG
	87-A30-086-040		C-TR,CSD1306E	C221	87-010-759-080		C-CAP,U, 0.1-25F
	87-A30-484-080		C-TR,KRA102S	C222	87-010-759-080		C-CAP,U, 0.1-25F
	87-A30-234-080		TR,CSC4115BC	C223	87-012-286-080		C-CAP,U 0.01-25 K B
	87-A30-515-080		TR,2SA19790/Y<K>	C224	87-012-286-080		C-CAP,U 0.01-25 K B
DIODE							
	87-A40-291-080		DIODE,1N4148M (CPT)	C225	87-A10-918-080		CAP,E 100-16 SMG
	87-A40-293-080		ZENER,DZ2.7M	C226	87-A12-066-080		CAP,E 47-16 SMG
	87-070-274-080		DIODE,1N4003 SEM	C227	87-A12-088-080		CAP,E 2.2-50 SMG
	87-A40-270-080		C-DIODE,MC2838	C228	87-A12-088-080		CAP,E 2.2-50 SMG
	87-A40-269-080		C-DIODE,MC2836	C229	87-A12-091-080		CAP,E 10-50 SMG
	87-020-465-080		DIODE,1SS133	C230	87-A12-091-080		CAP,E 10-50 SMG
	87-017-149-080		ZENER,HZS6A2L	C231	87-A12-068-080		CAP,E 470-16 SMG
				C232	87-A12-067-080		CAP,E 330-16 SMG
				C233	87-A12-066-080		CAP,E 47-16 SMG
				C234	87-012-195-080		C-CAP,U 100P-50 J CH<EZ>
				C234	87-012-199-080		C-CAP,U 220P-50 J CH<K>
				C301	87-012-276-080		C-CAP,U 1500P-50 K B
				C302	87-012-276-080		C-CAP,U 1500P-50 K B
				C305	87-012-268-080		C-CAP,U 330P-50 B
				C306	87-012-268-080		C-CAP,U 330P-50 B
				C307	87-010-785-080		C-CAP,U0.015-25BK
				C308	87-010-785-080		C-CAP,U0.015-25BK
				C309	87-012-278-080		C-CAP,U 2200P-50 B
				C310	87-012-278-080		C-CAP,U 2200P-50 B
				C311	87-A12-084-080		CAP,E 0.22-50 SMG
				C312	87-A12-084-080		CAP,E 0.22-50 SMG
				C313	87-A12-084-080		CAP,E 0.22-50 SMG
				C314	87-A12-084-080		CAP,E 0.22-50 SMG
				C315	87-A12-061-080		CAP,E 47-10 SMG
				C316	87-A12-061-080		CAP,E 47-10 SMG
				C317	87-012-172-080		C-CAP,U 10P-50 D CH
				C318	87-A12-090-080		CAP,E 4.7-50 SMG
				C319	87-A12-090-080		CAP,E 4.7-50 SMG
				C320	87-A12-065-080		CAP,E 33-16 SMG
				C321	87-A12-065-080		CAP,E 33-16 SMG
				C322	87-A12-090-080		CAP,E 4.7-50 SMG
				C323	87-A12-090-080		CAP,E 4.7-50 SMG
				C508	87-010-785-080		C-CAP,U0.015-25BK
				C509	87-A10-781-080		C-CAP,U 0.15-10 K B
				C510	87-A12-061-080		CAP,E 47-10 SMG
				C511	87-010-787-080		C-CAP,U 0.022-25 K B
				C512	87-010-759-080		C-CAP,U, 0.1-25F
				C513	87-012-178-080		C-CAP,U 18P-50 CH
				C514	87-012-184-080		C-CAP,U 33P-50 CH
MAIN C.B							
C101	87-012-286-080		C-CAP,U 0.01-25 K B1				
C107	87-012-286-080		C-CAP,U 0.01-25 K B				
C108	87-012-286-080		C-CAP,U 0.01-25 K B				
C109	87-012-286-080		C-CAP,U 0.01-25 K B				
C110	87-012-286-080		C-CAP,U 0.01-25 K B				
C112	87-012-286-080		C-CAP,U 0.01-25 K B				
C113	87-012-286-080		C-CAP,U 0.01-25 K B				
C114	87-012-195-080		C-CAP,U 100P-50CH				
C115	87-012-195-080		C-CAP,U 100P-50CH				
C117	87-012-195-080		C-CAP,U 100P-50CH				
C118	87-012-195-080		C-CAP,U 100P-50CH				
C119	87-012-195-080		C-CAP,U 100P-50CH				
C121	87-010-759-080		C-CAP,U, 0.1-25F				
C122	87-010-759-080		C-CAP,U, 0.1-25F				
C123	87-012-286-080		C-CAP,U 0.01-25 K B				
C124	87-012-286-080		C-CAP,U 0.01-25 K B				
C125	87-012-195-080		C-CAP,U 100P-50 J CH				
C126	87-012-195-080		C-CAP,U 100P-50 J CH				
C127	87-A10-730-080		CAP,E 1000-16 SMG				
C128	87-A12-069-080		CAP,E 22-25 SMG				
C132	87-010-759-080		C-CAP,U 0.1-25F				

REF. NO.	PART NO.	KANRI NO.	DESCRIPTION	REF. NO.	PART NO.	KANRI NO.	DESCRIPTION
C515	87-010-759-080		C-CAP,U, 0.1-25F	S708	87-A90-696-080		SW,TACT TS2103-03-430
C516	87-A12-063-080		CAP,E 220-10 SMG				
C517	87-012-274-080		CHIP CAP,U 1000P-50B				
C518	87-010-759-080		C-CAP,U, 0.1-25F	CONN C.B			
C519	87-010-759-080		C-CAP,U, 0.1-25F				
C520	87-012-195-080		C-CAP,U 100P-50CH	C610	87-012-274-080		C-CAP,U 1000P-50 K B<EZ>
C521	87-012-195-080		C-CAP,U 100P-50CH	CN603	87-A60-650-010		CONN,16P H GRY TUC-P16X-C1<EZ>
C522	87-012-195-080		C-CAP,U 100P-50CH	CN604	87-099-559-010		CONN,13P H TUC-P13X-B1<K>
C523	87-010-759-080		C-CAP,U, 0.1-25F	CN605	87-A60-189-010		CONN,16P V TUC-P16P-B1
C524	87-016-459-080		CAP,E 470-10 M SMG				
C525	87-012-286-080		CAP, U 0.01-25	AUX/TAPE-JACK C.B			
C526	87-010-759-080		C-CAP,U 0.1-25 Z F	C401	87-012-268-080		C-CAP,U 330P-50 B
C527	87-010-759-080		C-CAP,U 0.1-25 Z F	C402	87-012-268-080		C-CAP,U 330P-50 B
C528	87-010-759-080		C-CAP,U 0.1-25 Z F	C404	87-012-286-080		CAP, U 0.01-25
C529	87-010-759-080		C-CAP,U 0.1-25 Z F	C405	87-012-286-080		CAP, U 0.01-25
C530	87-010-759-080		C-CAP,U 0.1-25 Z F	C406	87-012-286-080		CAP, U 0.01-25
C531	87-012-274-080		C-CAP,U 1000P-50 K B	C407	87-012-286-080		CAP, U 0.01-25
C532	87-A10-706-080		C-CAP,U 0.33-16 Z F	C408	87-012-286-080		CAP, U 0.01-25
C650	87-012-180-080		C-CAP,U 22P-50 CH<EZ>	C409	87-012-195-080		C-CAP,U 100P-50CH
C651	87-012-184-080		C-CAP,U 33P-50 CH<EZ>	C410	87-012-195-080		C-CAP,U 100P-50CH
C652	87-012-286-080		CAP, U 0.01-25<EZ>	C411	87-012-195-080		C-CAP,U 100P-50CH
C653	87-012-286-080		CAP, U 0.01-25<EZ>	C412	87-012-286-080		CAP, U 0.01-25
C654	87-A12-091-080		CAP,E 10-50 SMG<EZ>	C413	87-012-286-080		CAP, U 0.01-25
C655	87-012-270-080		CAP, U 470P-50<EZ>	C414	87-012-286-080		CAP, U 0.01-25
C656	87-012-199-080		C-CAP,U 220P-50 J CH<EZ>	CN401	87-099-198-010		CONN,10P V BLK 6216
C657	87-012-199-080		C-CAP,U 220P-50 J CH<EZ>	CN403	87-099-194-010		CONN,6P V BLK 6216
C658	87-012-274-080		CHIP CAP,U 1000P-50B<EZ>	CN405	87-A61-044-010		CONN,19P H BLUE 52641-1914
C659	87-010-759-080		C-CAP,U, 0.1-25F<EZ>	CN406	87-099-212-010		CONN,5P V BLK 6216
C660	87-A12-091-080		CAP,E 10-50 SMG<EZ>	FC401	88-910-101-110		FF-CABLE, 10P 1.25 100MM
C661	87-012-286-080		CAP, U 0.01-25<EZ>	FC403	88-906-151-110		FF-CABLE,6P 1.25
C662	87-012-286-080		CAP, U 0.01-25<EZ>	FC406	88-905-151-110		FF-CABLE, 5P 1.25 150MM
CN101	87-A61-043-010		CONN,20P H BLK 52641-2011	J401	80-MT3-631-010		JACK,PIN 2P EARTH
CN102	87-A61-581-010		CONN,18P V BLK 52641-1811	JW403	87-008-372-080		FLTR, EMI BL01 RN1
CN103	87-A61-042-010		CONN,19P H BLK 52641-1911	JW404	87-008-372-080		FLTR, EMI BL01 RN1<K>
CN402	87-A60-058-010		CONN,10P V 9604S-10C				
CN404	87-A60-061-010		CONN,06P V 9604S-06C	L&ED-L C.B			
CN407	87-A60-062-010		CONN,05P V 9604S-05C				
CN601	87-A60-189-010		CONN,16P V TUC-P16P-B1<EZ>	C710	87-012-286-080		C-CAP,U 0.01-25 K B
CN607	87-099-570-010		CONN,13P V TUC-P13P-B1<K>	CN701	87-A60-619-010		CONN,2P V 2MM JMT
CN705	87-099-198-010		CONN,10P V BLK 6216	D701	87-A40-640-010		LED,SELU1E10CXM BLUE-EF
△ JW121	87-A90-645-080		PROTECTOR,0.2A 491-60V				
L501	87-A50-333-010		COIL,OSC 9.43MHZ	LED-R C.B			
L502	87-003-102-080		COIL, 10UH J LAL02				
L601	87-A50-027-010		COIL,1 POLE MPX(TOK)	C711	87-012-286-080		C-CAP,U 0.01-25 K B
L602	87-A50-027-010		COIL,1 POLE MPX(TOK)	CN702	87-A60-619-010		CONN,2P V 2MM JMT
L650	87-003-098-080		COIL,2.2UH K LAL02<EZ>	D702	87-A40-640-010		LED,SELU1E10CXM BLUE-EF
X601	87-A70-307-010		VIB,XTAL 4.332MHZ CSA-309ST<EZ>				
FRONT C.B				LCD-LED C.B			
C701	87-012-274-080		CHIP CAP,U 1000P-50B	C713	87-012-286-080		C-CAP,U 0.01-25 K B
C702	87-010-560-040		CAP,E 10-50 M 5L MA	C714	87-012-286-080		C-CAP,U 0.01-25 K B
C703	87-012-195-080		C-CAP,U 100P-50CH	C715	87-012-286-080		C-CAP,U 0.01-25 K B
C705	87-012-195-080		C-CAP,U 100P-50CH	C716	87-012-286-080		C-CAP,U 0.01-25 K B
C706	87-010-759-080		C-CAP,U, 0.1-25F	CN704	87-A60-619-010		CONN,2P V 2MM JMT
C707	87-010-759-080		C-CAP,U, 0.1-25F	D703	87-A41-092-080		LED,SMLU1DE16C BL/GR
C708	87-010-759-080		C-CAP,U, 0.1-25F	D704	87-A41-092-080		LED,SMLU1DE16C BL/GR
CN703	87-A60-058-010		CONN,10P V 9604S-10C	TUNER C.B			
CNA701	88-805-020-890		CONN ASSY,2P 80				
CNA702	88-805-020-890		CONN ASSY,2P 80	C772	87-012-286-080		CAP, U 0.01-25
CNA704	88-805-020-640		CONN ASSY,2P 60MM	C786	87-012-286-080		CAP, U 0.01-25
FC703	88-910-151-110		FF-CABLE, 10P 1.25 150MM	C788	87-012-167-080		C-CAP,U 5P-50 CH
LCD701	8B-CF1-611-010		LCD,RCM7160W-B	C789	87-A11-228-080		C-CAP,U 0.027-25 K B
S701	87-A90-696-080		SW,TACT TS2103-03-430	C790	87-A11-228-080		C-CAP,U 0.027-25 K B
S702	87-A90-696-080		SW,TACT TS2103-03-430	C791	87-010-831-080		C-CAP,U 0.1-16 Z F
S703	87-A90-696-080		SW,TACT TS2103-03-430	C792	87-012-286-080		CAP, U 0.01-25
S704	87-A90-696-080		SW,TACT TS2103-03-430	C793	87-A11-056-080		C-CAP,U 1-10 Z F
S705	87-A90-696-080		SW,TACT TS2103-03-430	C795	87-012-286-080		CAP, U 0.01-25
S706	87-A90-696-080		SW,TACT TS2103-03-430	C798	87-010-831-080		C-CAP,U 0.1-16 Z F
S707	87-A90-696-080		SW,TACT TS2103-03-430	C799	87-010-982-040		CAP,E 33-25 GAS

REF. NO.	PART NO.	KANRI NO.	DESCRIPTION	REF. NO.	PART NO.	KANRI NO.	DESCRIPTION
C800	87-012-191-080		C-CAP,U 68P-50 J CH-16	C984	87-012-286-080		CAP, U 0.01-25
C801	87-A11-056-080		C-CAP,U 1-10 Z F	C985	87-012-195-080		C-CAP,U 100P-50CH
C802	87-010-829-080		CAP, U 0.047-16 Z F	C987	87-012-286-080		CAP, U 0.01-25
C804	87-010-555-040		CAP,E 100-10 GAS	C989	87-012-286-080		CAP, U 0.01-25
C807	87-A10-463-080		C-CAP,U 0.47-10 Z F	C990	87-012-195-080		C-CAP,U 100P-50CH
C808	87-A11-056-080		C-CAP,U 1-10 Z F	C991	87-012-182-080		C-CAP,U 27P-50 J CH
C809	87-A11-056-080		C-CAP,U 1-10 Z F	C992	87-012-172-080		C-CAP,U 10P-50 D CH
C815	87-A10-463-080		C-CAP,U 0.47-10 Z F	C993	87-012-274-080		CHIP CAP,U 1000P-50B
C816	87-A10-463-080		C-CAP,U 0.47-10 Z F	C994	87-012-195-080		C-CAP,U 100P-50CH
C818	87-012-276-080		C-CAP,U 1500P-50 K B	C995	87-012-274-080		CHIP CAP,U 1000P-50B
C821	87-A11-063-080		C-CAP,S 4.7-10 Z F	C996	87-012-195-080		C-CAP,U 100P-50CH
C822	87-012-270-080		C-CAP,U 470P-50 K B	C997	87-010-831-080		C-CAP,U,0.1-16F
C823	87-012-274-080		CHIP CAP,U 1000P-50B	C998	87-010-553-040		CAP,E 47-16 GAS
C824	87-A11-063-080		C-CAP,S 4.7-10 Z F	C999	87-012-286-080		CAP, U 0.01-25
C825	87-A11-317-080		C-CAP,U 0.068U-16 K B	CF831	87-008-423-010		FLTR,SFE10.7MS3G-A
C831	87-010-552-040		CAP,E 22-16 GAS	CF832	82-785-747-010		CF,MS2 GHY,R
C837	87-A12-022-080		C-CAP,U 0.22-16 Z F	CN991	87-A60-650-010		CONN,16P H GRY TUC-P16X-C1
C842	87-010-831-080		C-CAP,U 0.1-16 Z F	D901	87-A41-048-040		C-VARI-CAP,HVM16-03 TL
C844	87-012-286-080		C-CAP,U 0.01-25	D902	87-A41-048-040		C-VARI-CAP,HVM16-03 TL
C850	87-A11-056-080		C-CAP,U 1-10 Z F	D903	87-A41-048-040		C-VARI-CAP,HVM16-03 TL
C851	87-012-286-080		CAP, U 0.01-25	J832	87-A61-534-010		TERMINAL,ANT PAL AJ-2021
C852	87-012-286-080		CAP, U 0.01-25	J940	87-A60-633-010		CONN,2P H 2.5MM JMT
C853	87-012-286-080		CAP, U 0.01-25	JW959	87-A11-132-080		CAP,TC U 0.01-50 K B
C859	87-010-831-080		C-CAP,U 0.1-16F	L801	87-A50-694-010		COIL,FM-DET 2 (COILS)
C860	87-012-286-080		CAP, U 0.01-25	L802	87-A91-551-010		FLTR,PCFZJH-450 L(TOK)
C899	87-018-134-080		CAP,TC U 0.01-16	L811	87-005-847-080		COIL,2.2UH (CECS)
C901	87-012-162-080		C-CAP,U 1P-50 CK	L832	87-005-847-080		COIL,2.2UH K (CECS)
C902	87-012-165-080		C-CAP,U 3P-50 CH	L901	86-ZA1-612-010		COIL,FM ANT/RF-1-Z
C903	87-012-164-080		C-CAP,U 2P-50 CK	L902	86-ZA1-613-010		COIL,FM ANT/RF-2-Z
C904	87-A12-348-080		C-CAP,U 560P-25 J CH	L903	87-003-098-080		COIL,2.2UH LAL02
C905	87-012-162-080		C-CAP,U 1P-50 CK	L904	86-ZA1-613-010		COIL,FM ANT/RF-2-Z
C906	87-012-172-080		C-CAP,U 10P-50 D CH	L905	86-ZA1-612-010		COIL,FM ANT/RF-1-Z
C907	87-012-166-080		C-CAP,U 4P-50 CH	L906	87-005-847-080		COIL,2.2UH K (CECS)
C908	87-012-165-080		C-CAP,U 3P-50 CH	L907	86-ZA1-614-010		COIL,FM OSC-Z
C909	86-ZA1-615-080		C-CAP,U 680P-25 J CH	L908	88-ZA1-624-010		COIL,FM IFT 7-6.2 (COILS)
C910	87-012-164-080		C-CAP,U 2P-50 CK	L941	87-A50-020-010		COIL,ANT LW(COI) 252KHZ
C911	87-012-166-080		C-CAP,U 4P-50 CH	L942	87-A50-019-010		COIL,OSC LW(COI) 856KHZ
C912	87-012-195-080		C-CAP,U 100P-50CH	L951	8A-NF8-668-010		COIL,AM PACK 2(TOK)
C913	86-ZA1-616-080		C-CAP,U 0.01-50 K B (MUR)	R790	87-012-286-080		CAP, U 0.01-25
C914	86-ZA1-616-080		C-CAP,U 0.01-50 K B (MUR)	TC942	87-A91-774-080		TRIMMER,PLY 30P 6.8X5.4 CDYL
C915	86-ZA1-616-080		C-CAP,U 0.01-50 K B (MUR)	X991	87-A70-061-010		VIB,XTAL 4.500MHZ CSA-309
C916	86-ZA1-616-080		C-CAP,U 0.01-50 K B (MUR)				
C917	87-012-178-080		C-CAP,U 18P-50 CH				
C918	87-012-172-080		C-CAP,U 10P-50 D CH				
C919	87-012-184-080		C-CAP,U 33P-50 CH				
C920	87-012-184-080		C-CAP,U 33P-50 CH				
C921	87-012-180-080		C-CAP,U 22P-50 CH				
C922	87-012-174-080		C-CAP,U 12P-50 J CH				
C923	86-ZA1-616-080		C-CAP,U 0.01-50 K B (MUR)				
C924	87-012-164-080		C-CAP,U 2P-50 CK				
C925	87-012-164-080		C-CAP,U 2P-50 CK				
C926	86-ZA1-616-080		C-CAP,U 0.01-50 K B (MUR)				
C927	87-012-195-080		C-CAP,U 100P-50CH				
C942	87-012-167-080		C-CAP,U 5P-50 CH				
C947	87-012-286-080		CAP, U 0.01-25				
C948	87-012-270-080		CAP, U 470P-50				
C952	87-012-286-080		CAP, U 0.01-25				
C957	87-012-174-080		C-CAP,U 12P-50 J CH				
C958	87-012-286-080		CAP, U 0.01-25				
C962	87-A11-056-080		C-CAP,U 1-10 Z F				
C963	87-010-831-080		C-CAP,U,0.1-16F				
C971	87-010-381-080		CAP, ELECT 330-16V				
C972	87-A11-063-080		C-CAP,S 4.7-10 Z F				
C973	87-012-286-080		CAP, U 0.01-25				
C974	87-012-286-080		CAP, U 0.01-25				
C976	87-010-831-080		C-CAP,U,0.1-16F				
C979	87-012-195-080		C-CAP,U 100P-50CH				
C981	87-010-553-040		CAP,E 47-16 GAS				
C982	87-010-831-080		C-CAP,U,0.1-16F				
C983	87-A11-132-080		CAP,TC U 0.01-50 K B				

○チップ抵抗部品コード/CHIP RESISTOR PART CODE

チップ抵抗部品コードの成り立ち

Chip Resistor Part Coding

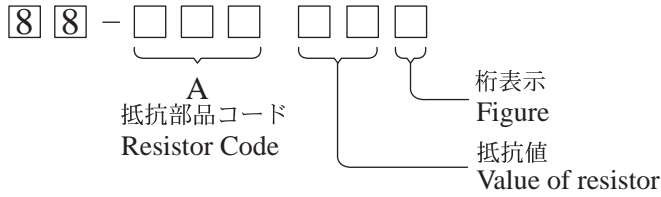

チップ抵抗
Chip resistor

容量 Wattage	種類 Type	許容誤差 Tolerance	記号 Symbol	寸法/Dimensions (mm)			抵抗コード : A Resistor Code : A	
				外形/Form	L	W		t
1/16W	1005	± 5%	CJ		1.0	0.5	0.35	104
1/16W	1608	± 5%	CJ		1.6	0.8	0.45	108
1/10W	2125	± 5%	CJ		2	1.25	0.45	118
1/8W	3216	± 5%	CJ		3.2	1.6	0.55	128

TRANSISTOR ILLUSTRATION



E C B

CSC4115BC
CSD655E
KTC3198GR



E C B

2SC4115SRS



E C B

2SA1318T



E C B

2SA1979O/Y

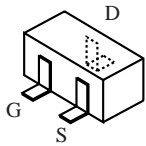

2SK2158
2SJ461-T1

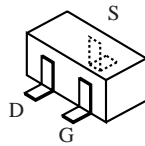

2SK360E

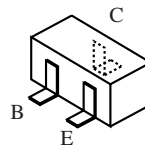

2SC2714O
2SC3052F
CSD1306E
KRA102S
KRA107S
KRC102S-RTK
KRC107S

A MAIN C.B <EZ>

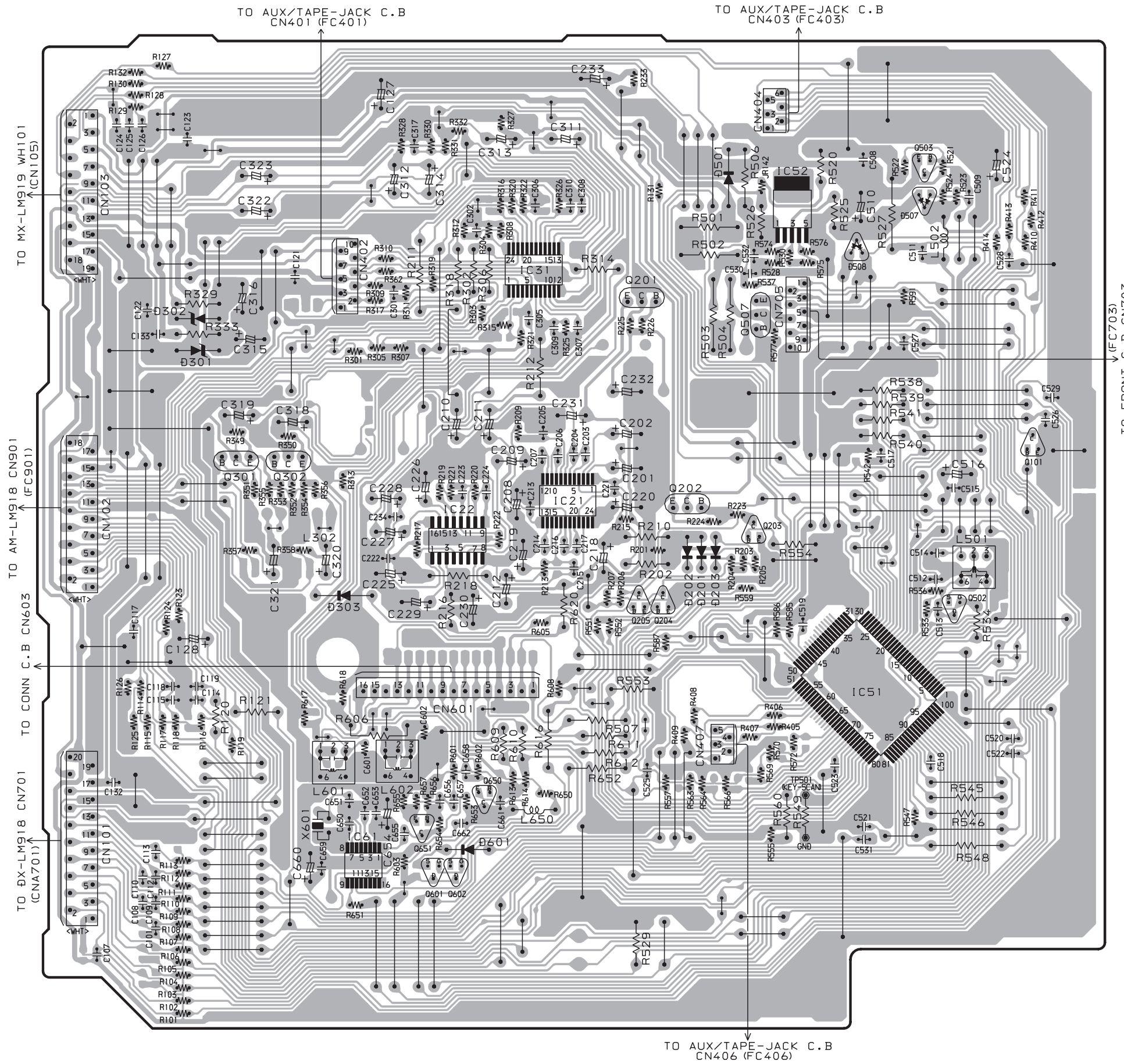

A MAIN C.B <K>

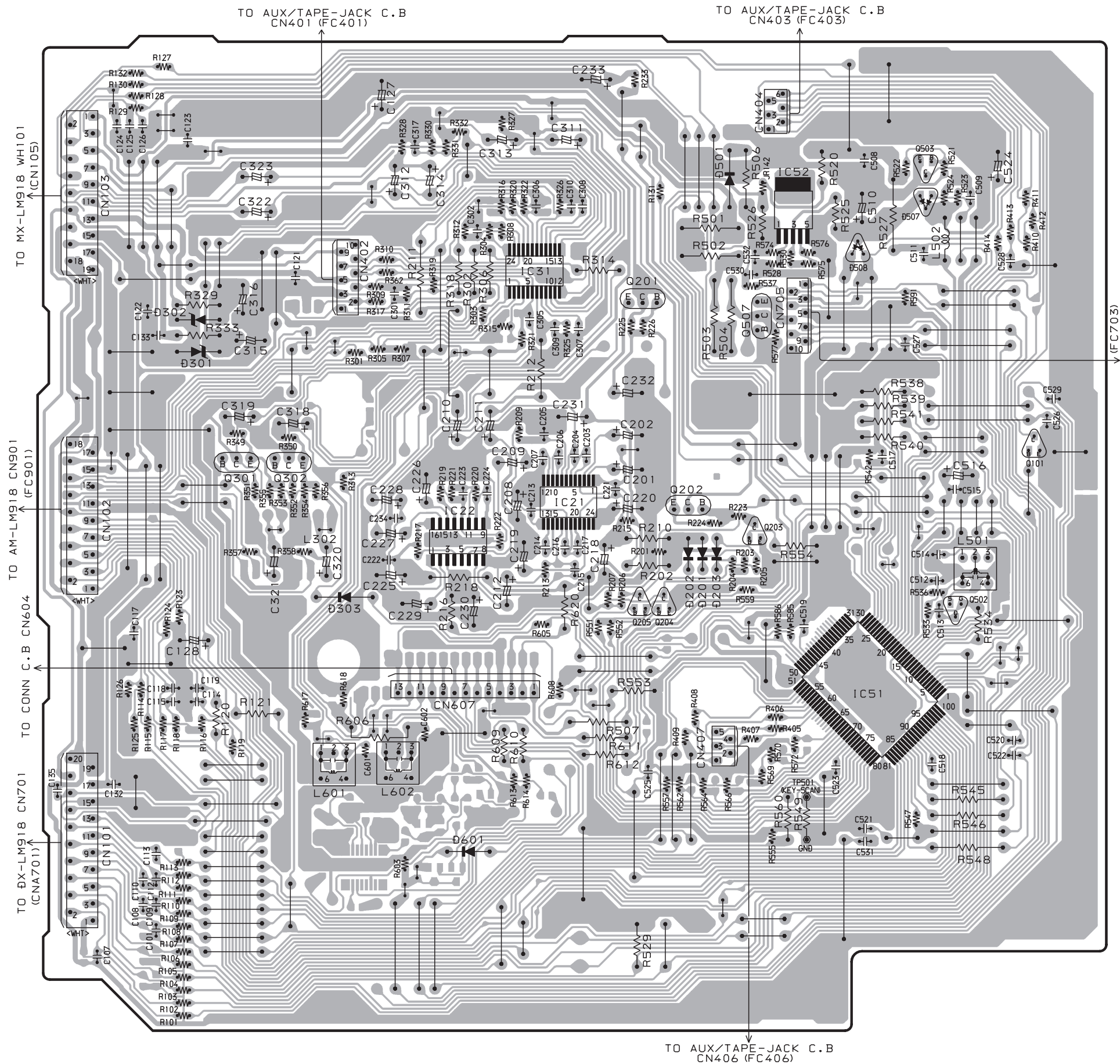

32	31	30	29	28	27	26	25	24	23	22	21	20	19	18	17	16	15	14	13	12	11	10	9	8	7	6	5	4	3	2	1
----	----	----	----	----	----	----	----	----	----	----	----	----	----	----	----	----	----	----	----	----	----	----	---	---	---	---	---	---	---	---	---

A
B
C
D
E
F
G
H
I
J
K
L
M
N
O
P
Q
R
S
T
U

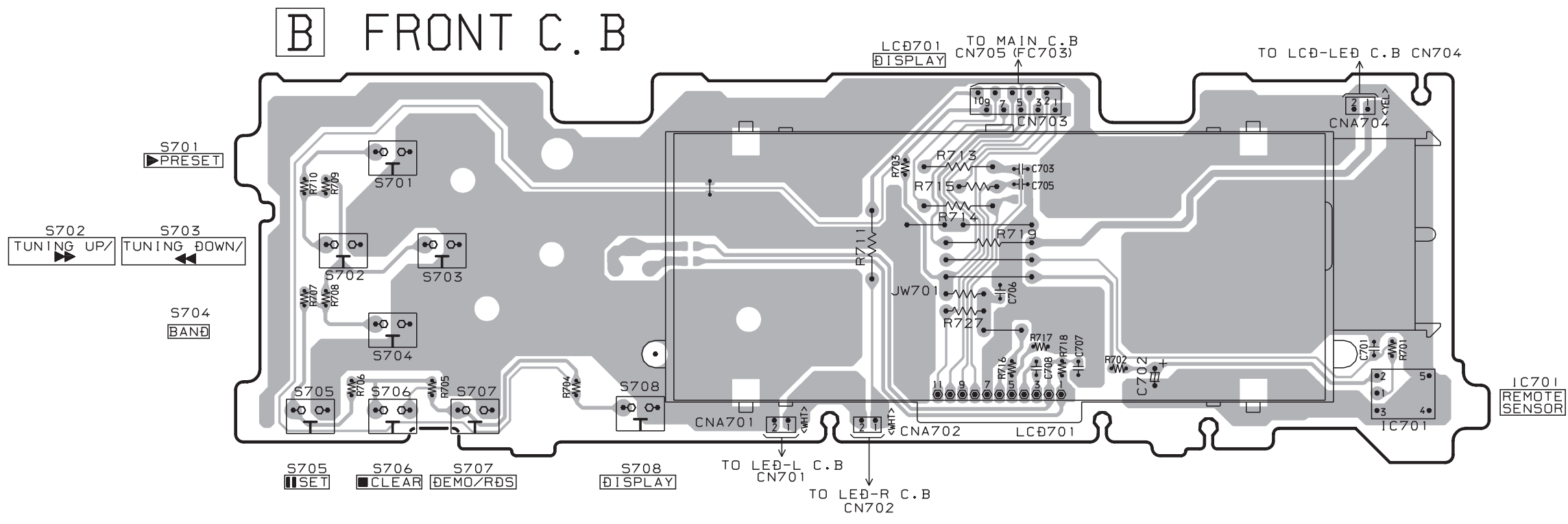
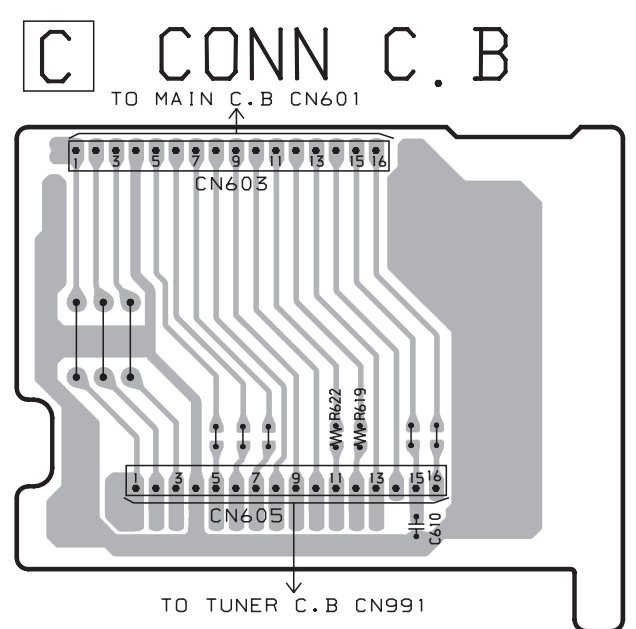
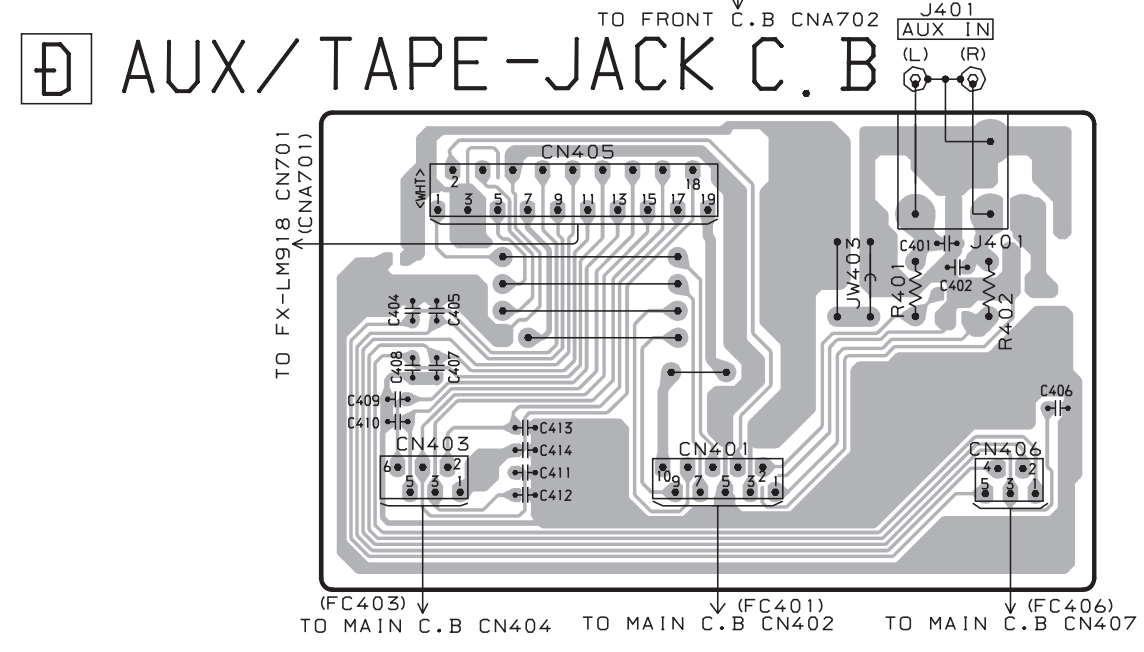
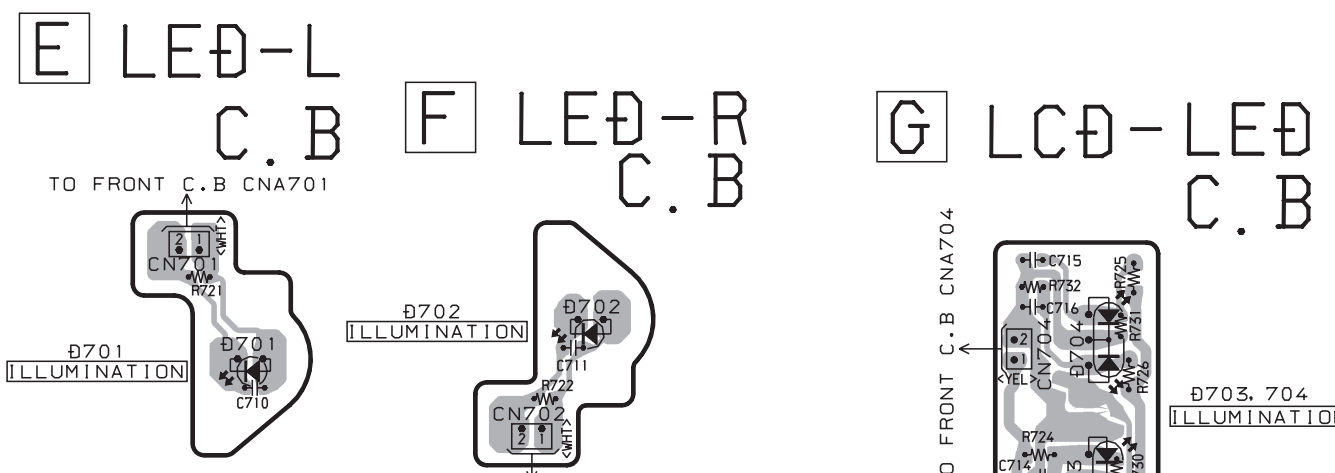

32	31	30	29	28	27	26	25	24	23	22	21	20	19	18	17	16	15	14	13	12	11	10	9	8	7	6	5	4	3	2	1
----	----	----	----	----	----	----	----	----	----	----	----	----	----	----	----	----	----	----	----	----	----	----	---	---	---	---	---	---	---	---	---

A
B
C
D
E
F
G
H
I
J
K
L
M
N
O
P
Q
R
S
T
U

E LED-L

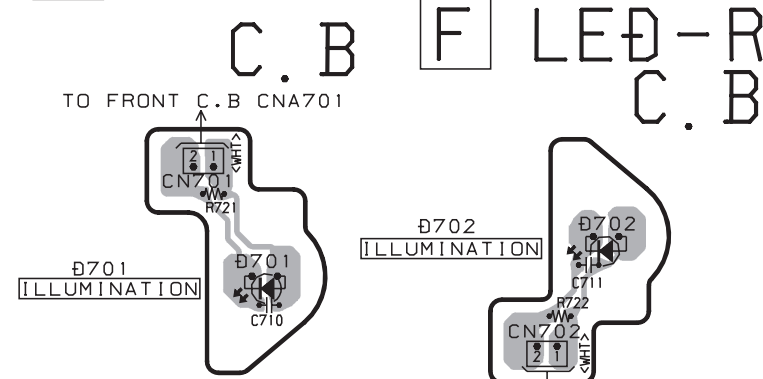

G LCD-LED

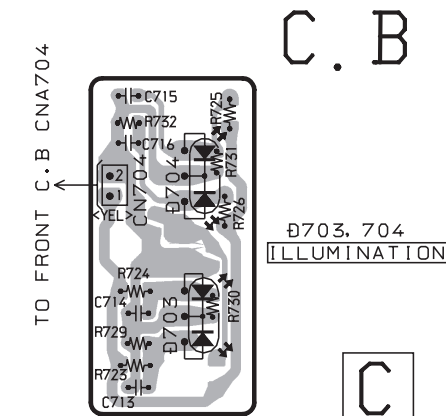

D AUX / TAPE - JACK C.B

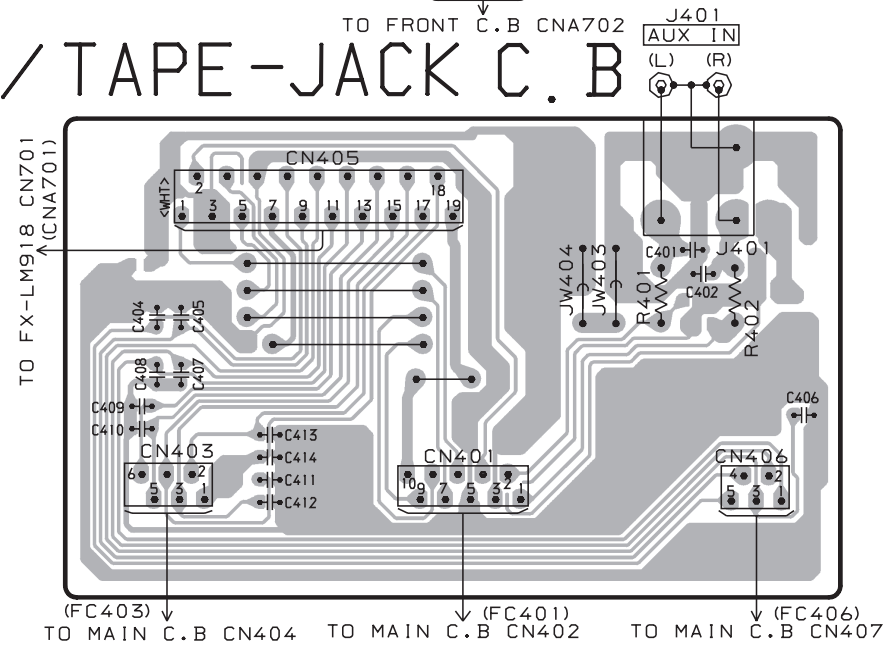

C CONN C.B

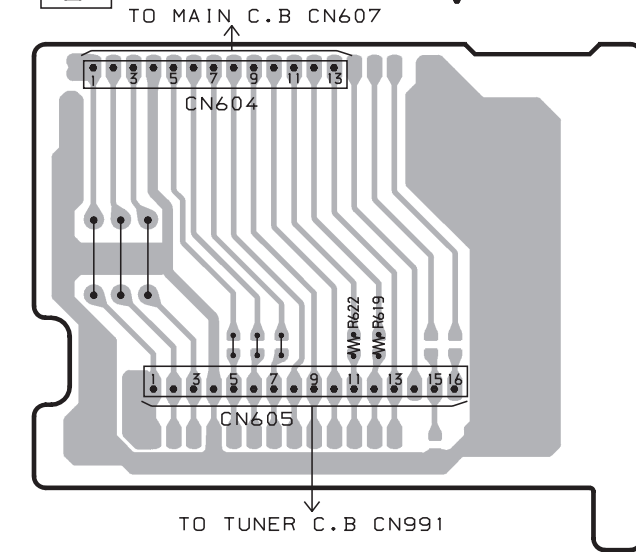

B FRONT C.B

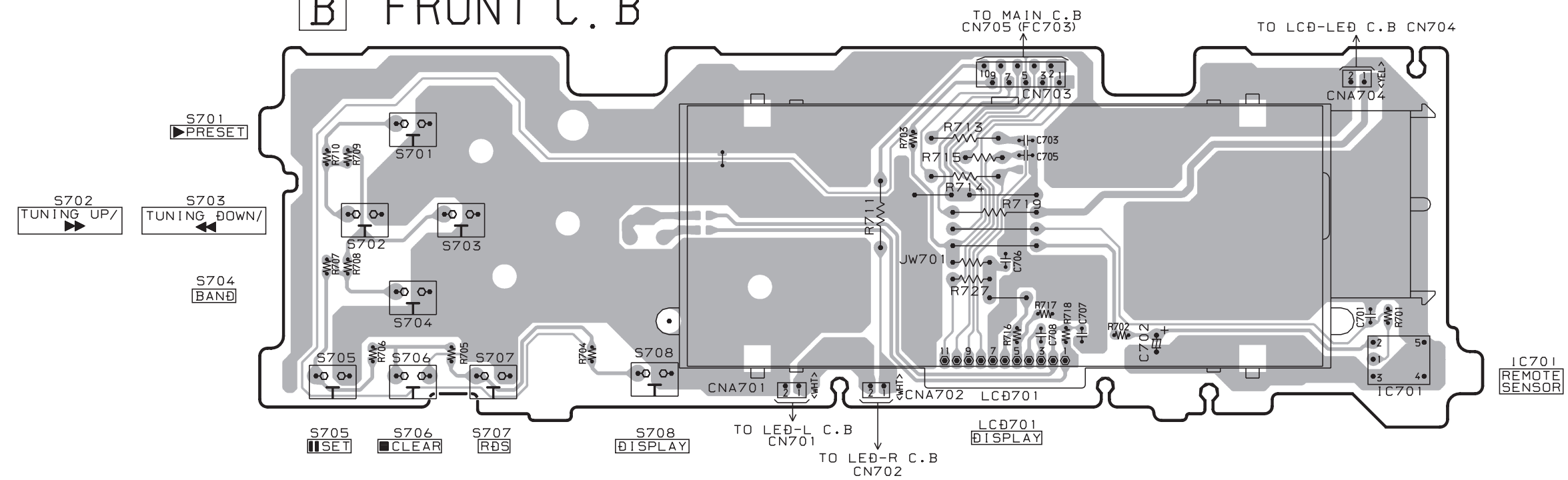

SCHEMATIC DIAGRAM - 1 (MAIN / FRONT / CONN / AUX / TAPE - JACK / LED - L / LED - R / LCD - LED)

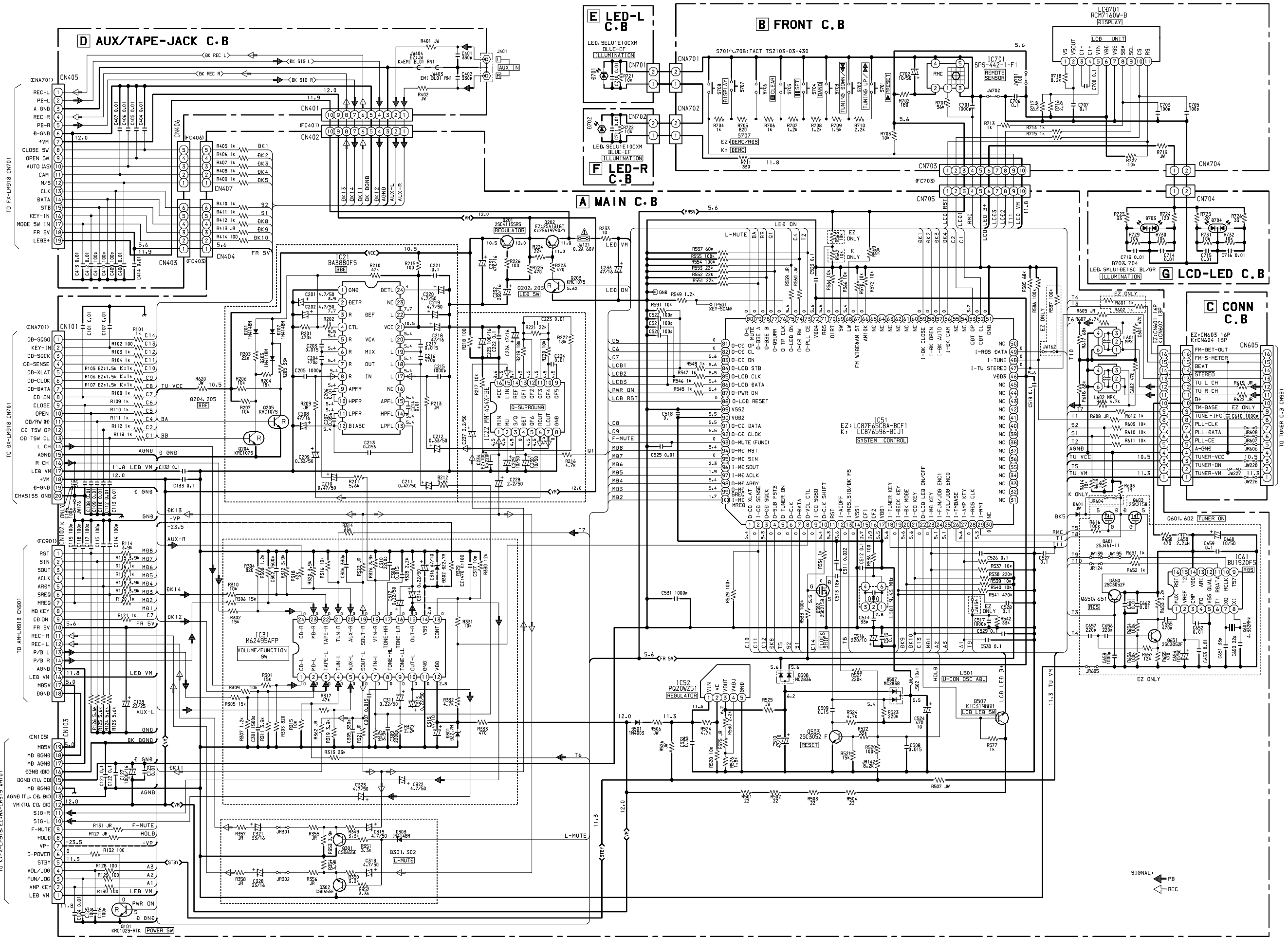

WIRING – 5 (TUNER)

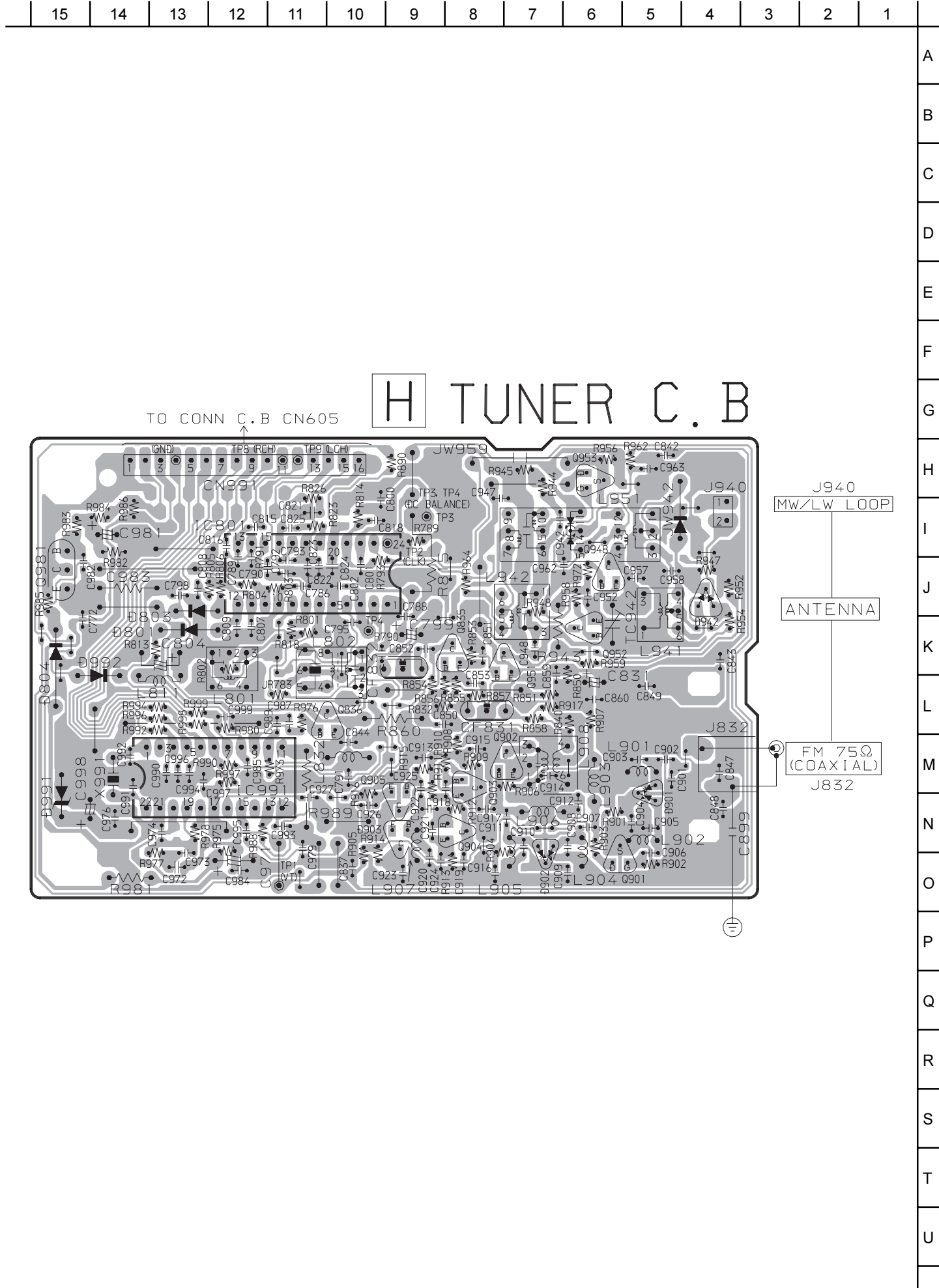

SCHEMATIC DIAGRAM-2 (TUNER)

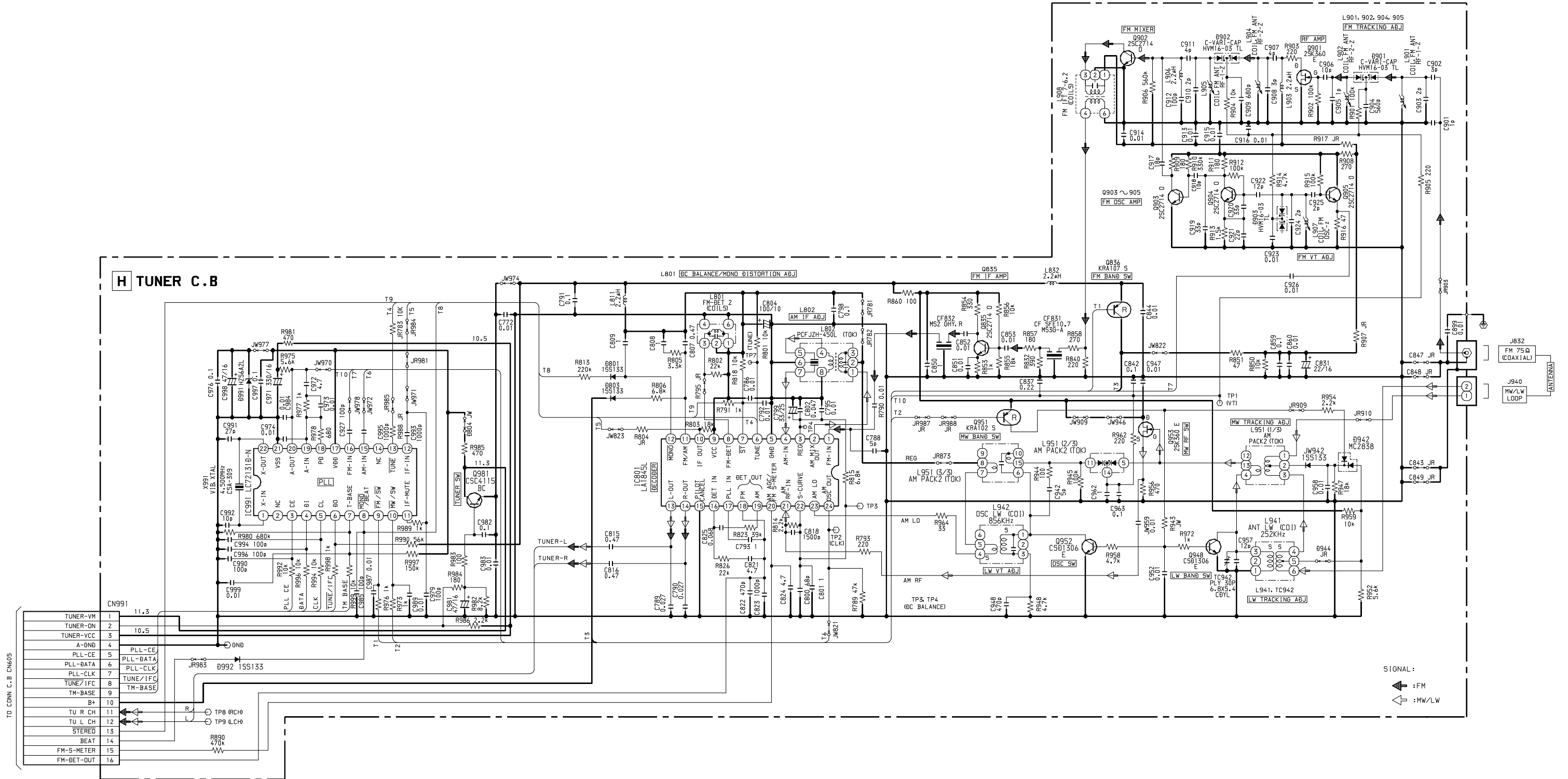

IC BLOCK DIAGRAM

IC, MM1454XFBE

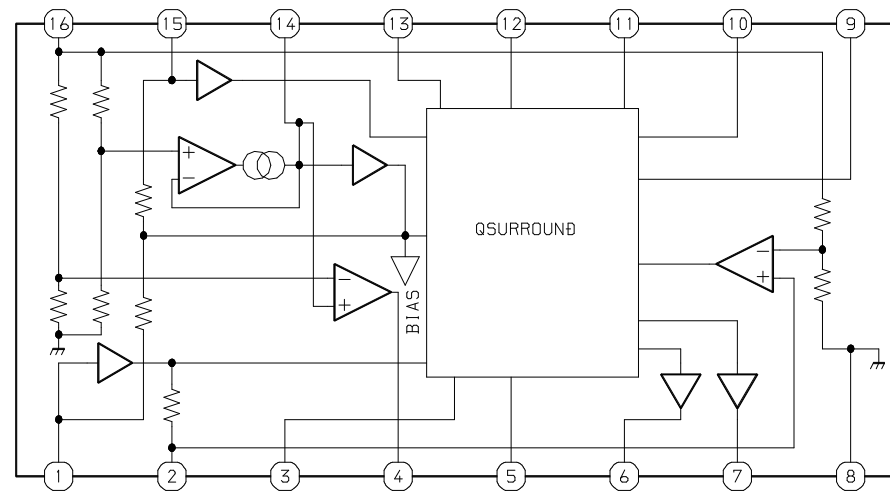

IC, BU1920FS

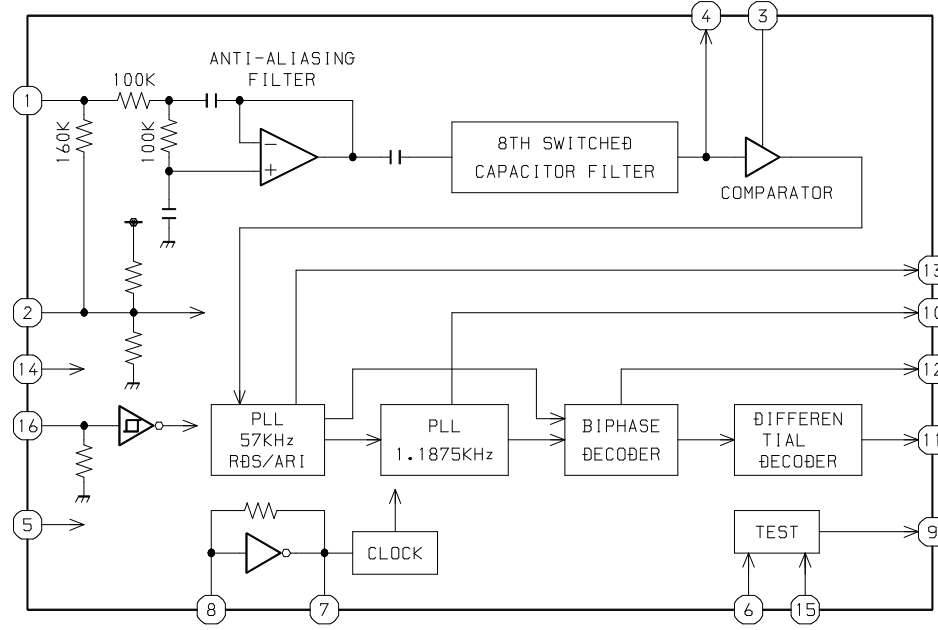

IC, LA1845L

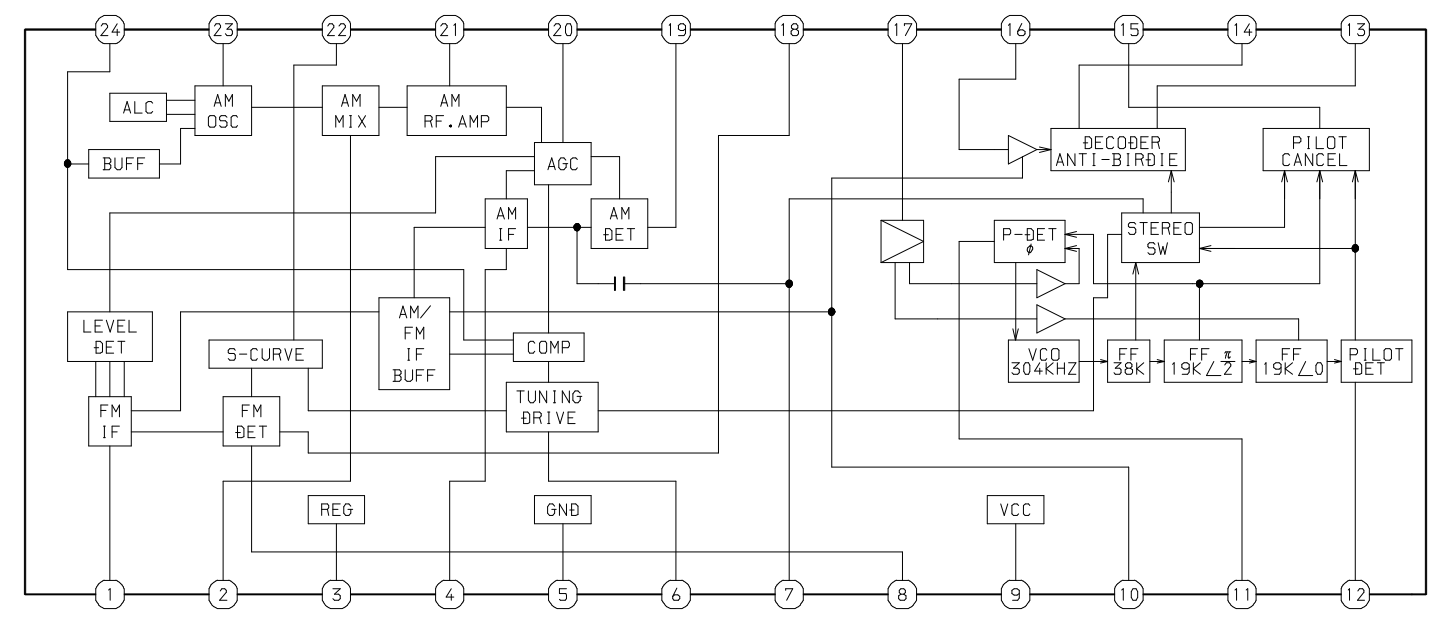

IC, BA3880FS

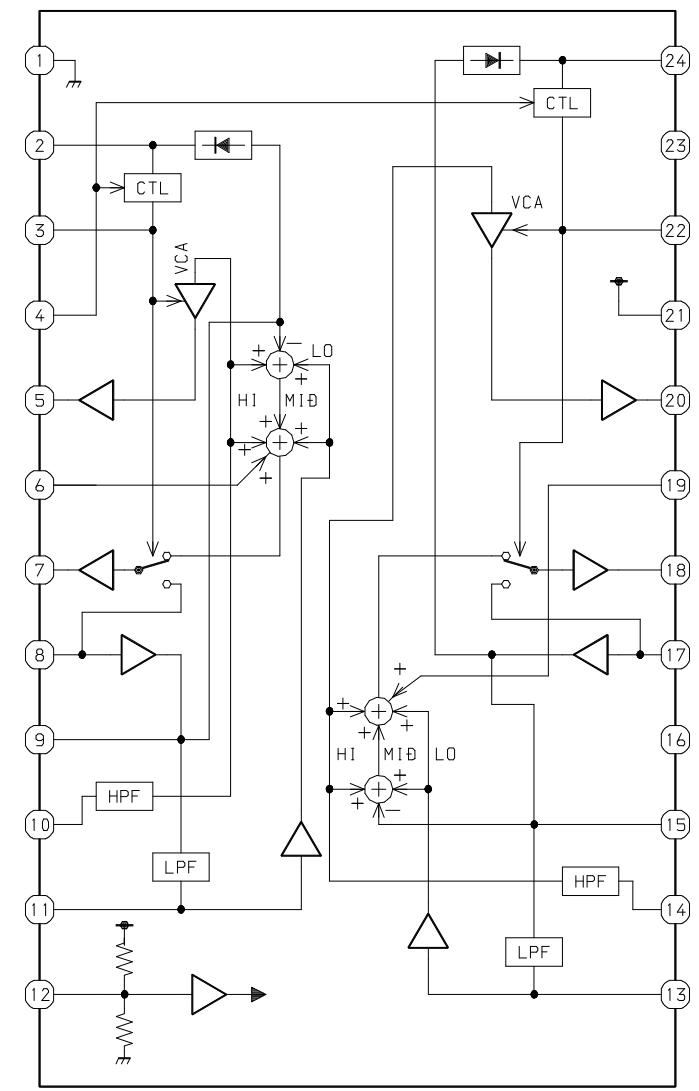

IC, LC72131D-N

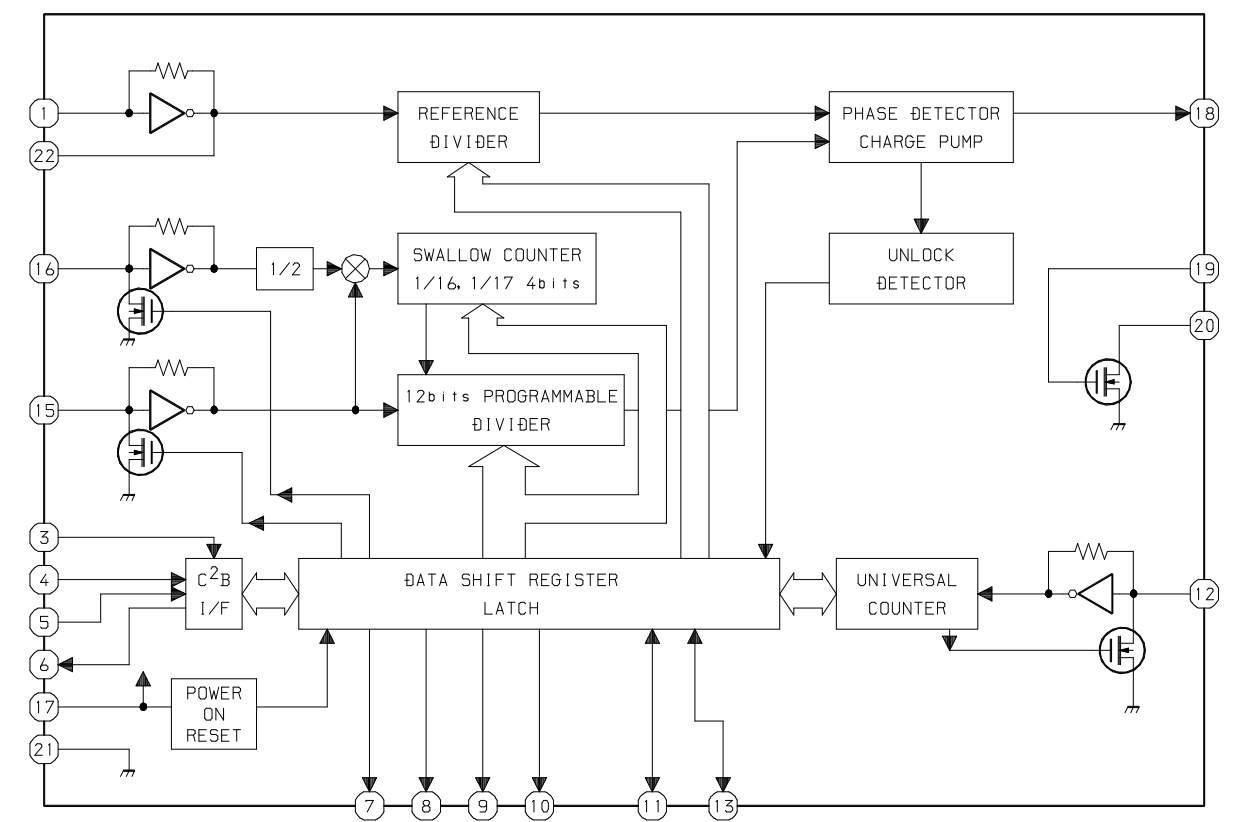

IC, M62495AFP

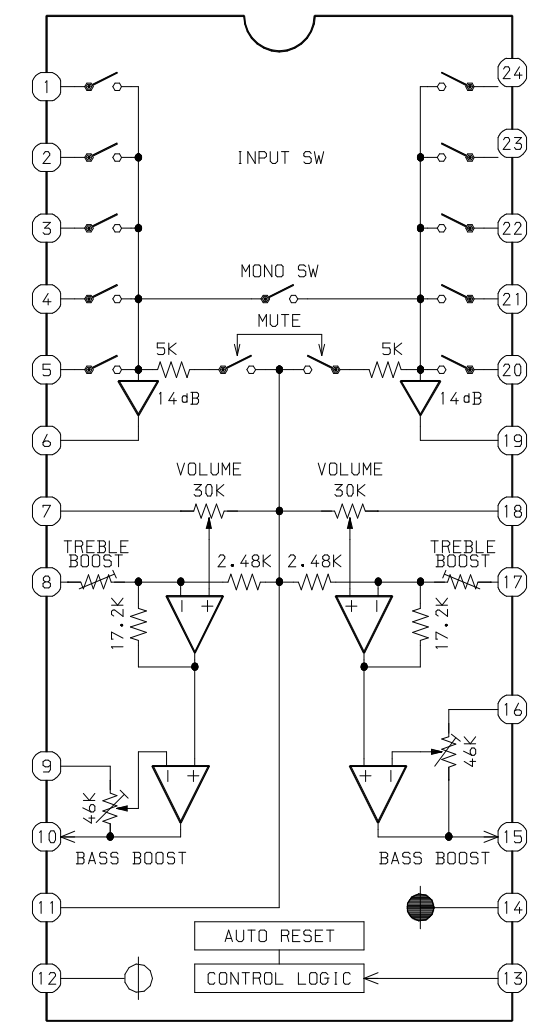

LCD DIAGRAM

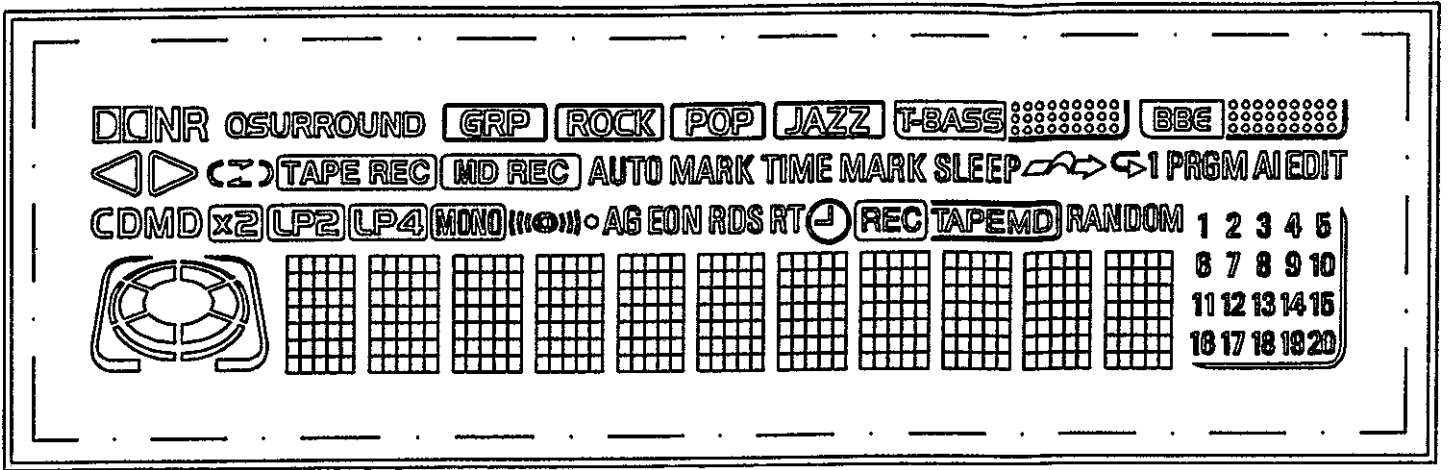

Segment side

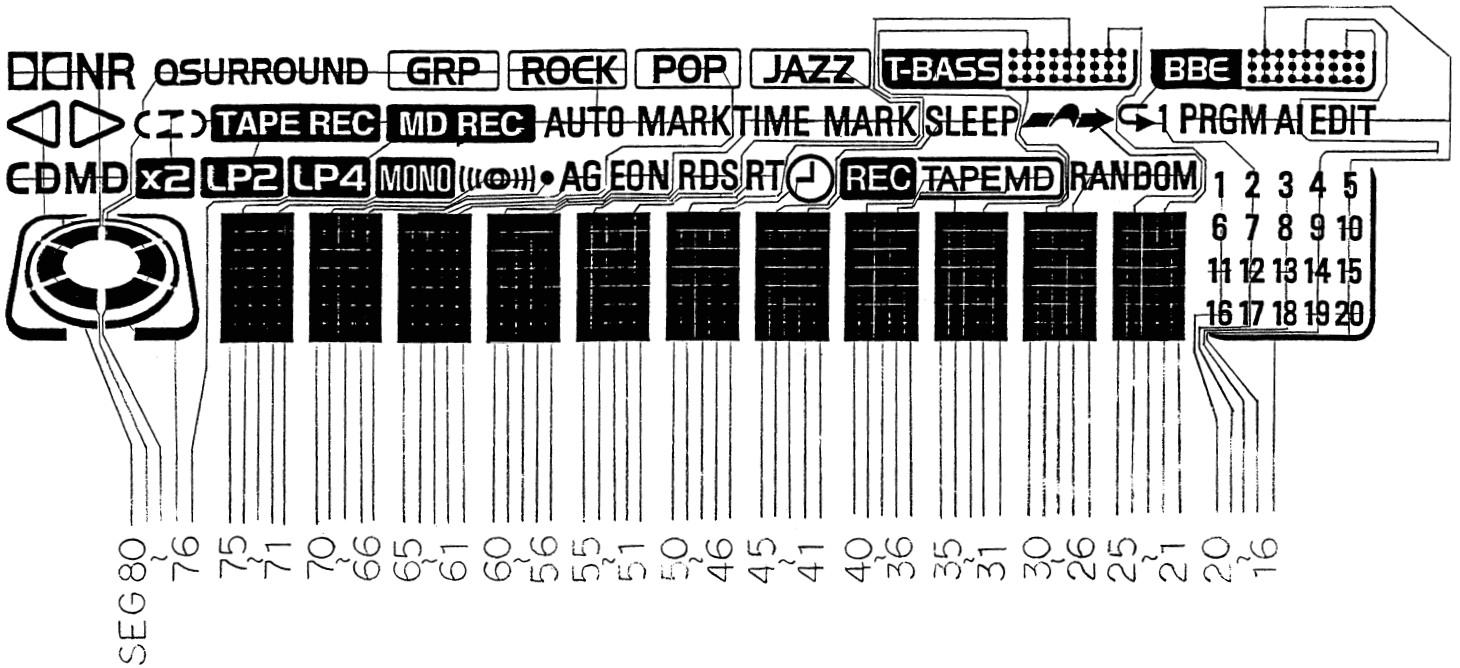

Common side

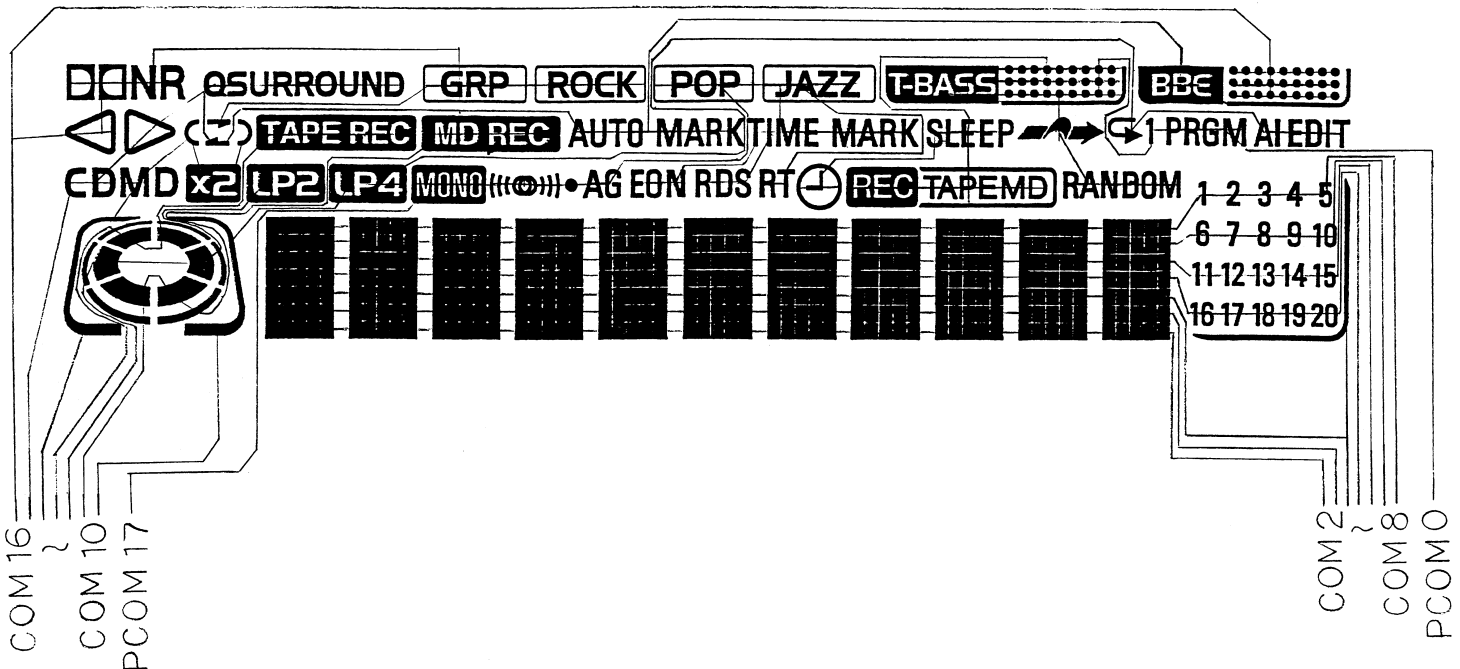

IC DESCRIPTION

EZ : IC, LC87F65C8A-BCF1, K : IC, LC876596-BCJ1

Pin No.	Pin Name	I/O	Description
1	O-CD XLAT	O	Latch output for CD DSP CXD2589Q 8pin.
2	I-CD SENSE	I	Sense input for CD DSP CXD2589Q 6pin.
3	O-CD SQCK	O	SQCK output for CD DSP CXD2589Q 4pin.
4	O-SUB FSTB	O	Strobe output for deck IC BU2092F 4pin.
5	O-TUNER ON	O	ON/OFF control for tuner block.
6	O-CLK	O	Clock output for deck IC BU2092F and tuner PLL IC, LC72131D-N.
7	O-DATA	O	Data output for deck IC BU2092F and tuner PLL IC, LC72131D-N.
8	O-VOL CTL	O	VOL/P.EQ IC M62495AFP control.
9	I-CD SQSO	I	SQSO input for CD DSP CXD2589Q.
10	O-CLK SHIFT	O	MICON clock shift control.
11	RST	I	Reset MICON.
12	I-ACOFF	I	AC OFF detect.
13	I-RDS-SIG/DK MS	I	RDS signal input (EZ only) / deck MS input.
14	VSS1	–	GND.
15	CF1	–	Connection of 9.43MHz oscillator.
16	CF2	–	Connection of 9.43MHz oscillator.
17	VDD1	–	μ-COM 5V.
18	I-TUNER KEY	I	AD input for tuner key.
19	I-DECK KEY	I	AD input for deck key.
20	I-DK MODE	I	AD input for mecha deck position.
21	I-CD KEY	I	AD input for CD key.
22	O-LCD LED ON/OFF	O	LCD back light control.
23	I-MD KEY	I	AD input for MD key.
24	I-FUNC/JOG ENC1	I	AD input for FUNC rotary encoder.
25	I-VOL/JOG ENC0	I	AD input for VOL rotary encoder.
26	I-TMBASE	I	Time base clock input.
27	I-AMP KEY	I	AD input for AMP key.
28	I-RDS CLK	I	RDS clock input. (EZ only)
29	I-RMT	I	System remote control signal input.
30 ~ 45	NC	–	Not connected.
46	VDD3	–	μ-COM 5V.
47	I-TU STEREO	I	Tuner stereo detect input.
48	I-TUNE	I	Data input for tuner PLL IC, LC72131D-N.
49	I-RDS DATA	I	RDS data input. (EZ only)
50	NC	–	Not connected.
51	GND	–	GND.
52	CDT CL	I	Input for CD tray close position.
53	CDT OP	I	Input for CD tray open position.
54, 55	NC	–	Not connected.
56	I-DK CAM	I	Input for mecha deck position (CAM).
57	I-DK AUTO	I	Input for mecha deck condition (AUTO).
58	I-DK OPEN	I	Input for mecha deck position (OPEN).

Pin No.	Pin Name	I/O	Description
59	I-DK CLOSE	I	Input for mecha deck position (CLOSE).
60 ~ 65	NC	–	Not connected.
66	AM10K	I	AM10K option. (Connected to GND through a resistor)
67	FM WIDE&AM ST	I	FM WIDE & AM ST option. (Connected to GND through a resistor)
68	LW	I	LW option. (Connected to FR5V through a resistor)
69	SW	I	SW option. (Connected to GND through a resistor)
70	OIRT	I	OIRT option. (Connected to GND through a resistor)
71	RDS	I	RDS option. (K : Connected to GND through a resistor) (EZ : Connected to FR5V through a resistor)
72	VDD4	–	μ-COM 5V.
73	O-PLL CE	O	Chip enable output for tuner PLL IC, LC72131D-N.
74	O-CD RW	O	CD RW switch control.
75	O-LED ON	O	Light LED control.
76	O-TP CLK	O	MICON clock test point. (Connected to GND through a resistor)
77	O-QSURR	O	Q-SURROUND IC ON/OFF control.
78	O-BBE B	O	BBE IC control output B.
79	O-BBE A	O	BBE IC control output A.
80	O-L MUTE	O	Line out mute control.
81	O-CD OP	O	Output for CD tray open control.
82	O-CD CL	O	Output for CD tray close control.
83	O-CD ON	O	Output for CD block ON/OFF control.
84	O-LCD STB	O	Strobe output for LCD driver.
85	O-LCD CLK	O	Clock for LCD driver control.
86	O-LCD DATA	O	Data for LCD driver control.
87	O-PWR ON	O	Set power ON/OFF output.
88	O-LCD RESET	O	Reset for LCD driver control.
89	VSS2	–	GND.
90	VDD2	–	μ-COM 5V.
91	O-CD DATA	O	Data for CD DSP CXD2589Q 7pin.
92	O-CD CLOK	O	Clock for CD SP CXD2589Q 9pin.
93	O-MUTE (FUNC)	O	Output of main mute.
94	O-MD RST	O	Reset control for MD unit.
95	O-MD SIN	O	Serial data output for MD unit.
96	I-MD SOUT	I	Serial data input for MD unit.
97	I-MD ACLK	I	Clock input for MD unit.
98	O-MD ARDY	O	Serial data standby for MD unit.
99	O-MD SREQ	O	Serial data request for MD unit.
100	I-MD MREQ	I	Serial data request from MD unit.

ADJUSTMENT

< TUNER SECTION >

1. Clock Frequency Check
Settings : • Test point : TP2 (CLK)
Method : Set to MW 1602kHz and check that the test point is 2052kHz \pm 45Hz.
2. MW VT Check
Settings : • Test point : TP1 (VT)
Method : Set to MW 1602kHz and check that the test point is less than 8.0V. Then set to MW 531kHz and check that the test point is more than 0.6V.
3. MW Tracking Adjustment
Settings : • Test point : TP8 (Rch), TP9 (Lch)
• Adjustment location : L951 (1/3)
Method : Set to MW 999kHz and adjust L951 (1/3) so that the test point becomes maximum.
4. LW VT Adjustment
Settings : • Test point : TP1 (VT)
• Adjustment location : L942
Method : Set to LW 144kHz and adjust L942 so that the test point becomes 1.3V \pm 0.05V. Then set to LW 290kHz and check that the test point is less than 8.0V.
5. LW Tracking Adjustment
Settings : • Test point : TP8 (Rch), TP9 (Lch)
• Adjustment location :
L941 144kHz
TC942 290kHz
Method : Set up TC942 to center before adjustment. The level at 144kHz is adjusted to MAX by L941. Then the level at 290kHz is adjusted to MAX by TC942.
6. AM IF Adjustment
Settings : • Test point : TP8 (Rch), TP9 (Lch)
• Adjustment location :
L802 450kHz
7. FM VT Adjustment
Settings : • Test point : TP1 (VT)
• Adjustment location : L907
Method : Set to FM 108.0MHz and adjust L907 so that the test point becomes 7.0V \pm 0.05V. Then set to FM 87.5MHz and check that the test point is more than 0.5V.

8. FM Tracking Adjustment
Settings : • Test point : TP8 (Rch), TP9 (Lch)
• Adjustment location : L901, L902, L904, L905
Method : Set to FM 108.0MHz and adjust L901, L902, L904, L905 so that the test point becomes maximum with minimum distortion. Then set to FM 98.0MHz and check that the test point is less than 13dB μ V.
9. DC Balance / Mono Distortion Adjustment
Settings : • Test point : TP3, TP4 (DC balance)
TP8 (Rch), TP9 (Lch)
(Mono Distortion)
• Adjustment location : L801
• Input level : 60dB μ V
Method : Set to FM 98.0MHz and adjust L801 so that the voltage between TP3 and TP4 becomes 0V \pm 500mV. Next, check that the distortion is less than 1.2%.

< MAIN SECTION >

10. μ -CON OSC Adjustment
Settings : • Test point : TP501 (KEY-SCAN) and (GND)
• Adjustment location : L501
Method : Insert AC plug while pressing POWER key and BAND function key. Then adjust L501 so that the frequency at the test point becomes 97.256 \pm 0.097Hz.

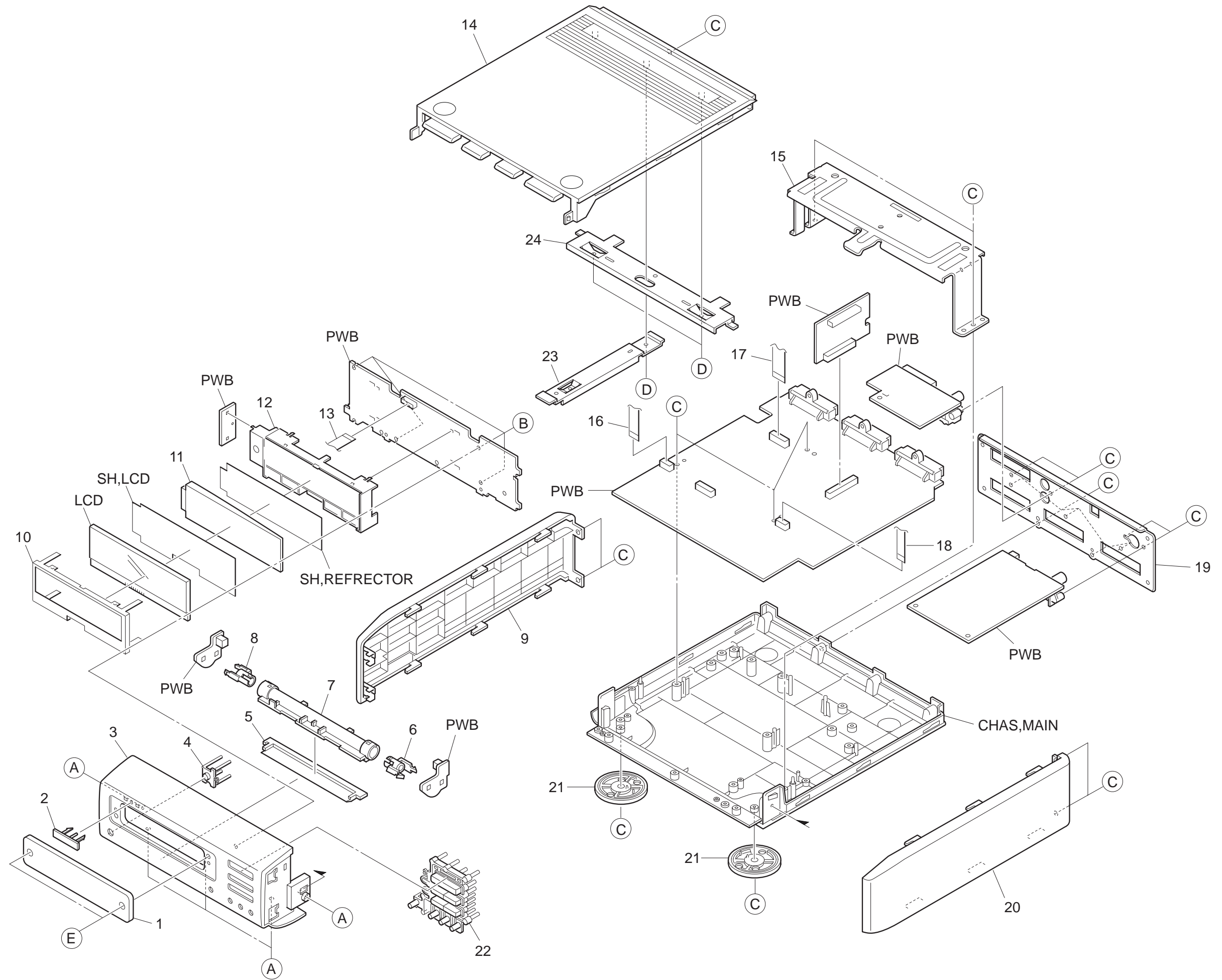

MECHANICAL PARTS LIST 1 / 1 <EZ>

REF. NO.	PART NO.	KANRI NO.	DESCRIPTION
1	8B-CF1-004-010		WINDOW,DISPLAY
2	8Z-CC3-007-010		BADGE,AIWA 27.5 ABS SIL
3	8B-CF1-012-010		CABI,FR TU EZ
4	8B-CF1-003-010		WINDOW,SENSOR
5	8B-CE1-018-010		REFLECTOR,FR
6	8Z-CE3-204-010		GUIDE,LED R
7	8B-CE1-208-010		GUIDE,LED CNT
8	8Z-CE3-203-010		GUIDE,LED L
9	8B-CF1-005-010		PANEL,SIDE L
10	8B-CF1-204-010		HLLDR,LCD
11	8B-CF1-007-010		REFLECTOR,LCD
12	8B-CF1-203-010		GUIDE,LCD
13	88-910-151-110		FF-CABLE, 10P 1.25 150MM
14	8B-CF1-011-010		PANEL, TOP
15	8B-CF1-205-010		PLATE, TOP
16	88-906-151-110		FF-CABLE, 6P 1.25
17	88-910-101-110		FF-CABLE, 10P 1.25 100MM
18	88-905-151-110		FF-CABLE, 5P 1.25 150MM
19	8B-CF1-009-010		PANEL, REAR TU EZ
20	8B-CF1-006-010		PANEL, SIDE R
21	8B-CE1-016-010		FOOT, DIA40 H4
22	8B-CF1-002-010		KEY, TUNER
23	8B-CE1-212-010		PLATE, TOP A
24	8B-CE1-213-010		PLATE, TOP B
A	87-721-096-410		QT2+3-10 GLD
B	87-B10-294-010		BVT2+2.6-8
C	87-067-703-010		TAPPING SCREW, BVT2+3-10
D	87-067-684-010		BVT2+2.6- W/O SLOT
E	8Z-CL1-034-010		S-SCREW, ZCL1

COLOR NAME TABLE

Basic color symbol	Color	Basic color symbol	Color	Basic color symbol	Color
B	Black	C	Cream	D	Orange
G	Green	H	Gray	L	Blue
LT	Transparent Blue	N	Gold	P	Pink
R	Red	S	Silver	ST	Titan Silver
T	Brown	V	Violet	W	White
WT	Transparent White	Y	Yellow	YT	Transparent Yellow
LM	Metallic Blue	LL	Light Blue	GT	Transparent Green
LD	Dark Blue	DT	Transparent Orange	GM	Metallic Green
YM	Metallic Yellow	DM	Metallic Orange	PT	Transparent Pink
LA	Aqua Blue	GL	Light Green	HT	Transparent Gray

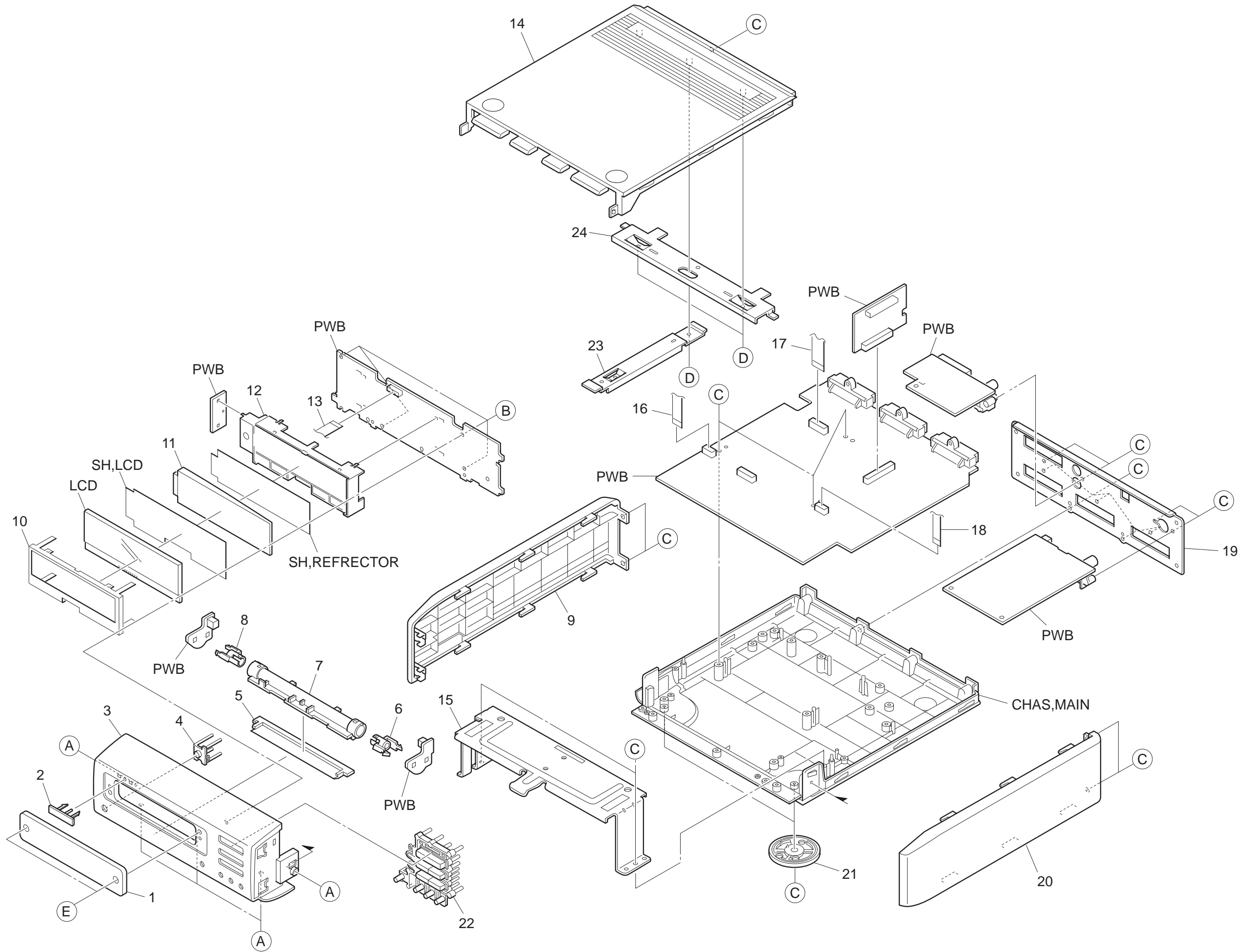

MECHANICAL PARTS LIST 1 / 1 <K>

REF. NO.	PART NO.	KANRI NO.	DESCRIPTION
1	8B-CF1-004-010		WINDOW,DISPLAY
2	8Z-CC3-007-010		BADGE,AIWA 27.5 ABS SIL
3	8B-CF1-001-010		CABI,FR TU
4	8B-CF1-003-010		WINDOW,SENSOR
5	8B-CE1-018-010		REFLECTOR,FR
6	8Z-CE3-204-010		GUIDE,LED R
7	8B-CE1-208-010		GUIDE,LED CNT
8	8Z-CE3-203-010		GUIDE,LED L
9	8B-CF1-005-010		PANEL,SIDE L
10	8B-CF1-204-010		HLDL,R LCD
11	8B-CF1-007-010		REFLECTOR,LCD
12	8B-CF1-203-010		GUIDE,LCD
13	88-910-151-110		FF-CABLE, 10P 1.25 150MM
14	8B-CF1-011-010		PANEL, TOP
15	8B-CF1-205-010		PLATE, TOP
16	88-906-151-110		FF-CABLE, 6P 1.25
17	88-910-101-110		FF-CABLE, 10P 1.25 100MM
18	88-905-151-110		FF-CABLE, 5P 1.25 150MM
19	8B-CF1-013-010		PANEL, REAR TU K
20	8B-CF1-006-010		PANEL, SIDE R
21	8B-CE1-016-010		FOOT, DIA40 H4
22	8B-CF1-002-010		KEY, TUNER
23	8B-CE1-212-010		PLATE, TOP A
24	8B-CE1-213-010		PLATE, TOP B
A	87-721-096-410		QT2+3-10 GLD
B	87-B10-294-010		BVT2+2.6-8
C	87-067-703-010		TAPPING SCREW, BVT2+3-10
D	87-067-684-010		BVT2+2.6- W/O SLOT
E	8Z-CL1-034-010		S-SCREW, ZCL1

COLOR NAME TABLE

Basic color symbol	Color	Basic color symbol	Color	Basic color symbol	Color
B	Black	C	Cream	D	Orange
G	Green	H	Gray	L	Blue
LT	Transparent Blue	N	Gold	P	Pink
R	Red	S	Silver	ST	Titan Silver
T	Brown	V	Violet	W	White
WT	Transparent White	Y	Yellow	YT	Transparent Yellow
LM	Metallic Blue	LL	Light Blue	GT	Transparent Green
LD	Dark Blue	DT	Transparent Orange	GM	Metallic Green
YM	Metallic Yellow	DM	Metallic Orange	PT	Transparent Pink
LA	Aqua Blue	GL	Light Green	HT	Transparent Gray

MODEL NO.

MX-LM918 / LM919

ELECTRICAL MAIN PARTS LIST

REF. NO.	PART NO.	KANRI NO.	DESCRIPTION	REF. NO.	PART NO.	KANRI NO.	DESCRIPTION
IC				C137	87-012-199-080		C-CAP,U 220P-50 J CH
	87-001-536-010	IC,NJM78M05FA		C138	87-012-199-080		C-CAP,U 220P-50 J CH
	87-A22-097-010	IC,KIA7812AP		C139	87-012-199-080		C-CAP,U 220P-50 J CH
				C140	87-012-199-080		C-CAP,U 220P-50 J CH
				C142	87-A12-317-080		C-CAP,U 0.1-50 Z F
TRANSISTOR				C143	87-A12-317-080		C-CAP,U 0.1-50 Z F
	87-026-609-080	TR,KTA1266GR		C146	87-A12-317-080		C-CAP,U 0.1-50 Z F
	87-A30-076-080	C-TR,2SC3052F		C147	87-A12-317-080		C-CAP,U 0.1-50 Z F
	87-A30-075-080	C-TR,2SA1235F		C148	87-012-282-080		C-CAP,U 4700P-50 K B
	87-A30-268-040	C-TR,2SA1514K(S)		C149	87-012-282-080		C-CAP,U 4700P-50 K B
	87-A30-074-080	C-TR,RT1P 141C		C150	87-010-831-080		C-CAP,U 0.1-16 Z F<EZ>
	87-A30-196-080	TR,2SC4115SRS		C401	87-A10-831-080		CAP,E 1000-25 M SMG
	89-406-555-080	TR,2SD655E		CN101	87-099-545-010		CONN,14P V BLK TKC-M
	87-A30-105-080	C-TR,RT1P 441C		CN102	87-A60-624-010		CONN,7P V 2MM JMT
	87-A30-190-080	TR,CC5551		CN103	87-A60-539-010		CONN,5P V TUC-P05P-B1
	87-A30-214-010	TR,2SB1344		CN104	87-049-469-010		CONN,4P V WHT EH
	87-A30-215-010	TR,2SD2025		J101	87-099-801-010		JACK,PIN 1P BLK W/O SW
	87-A30-106-070	C-TR,CMBT5551		L100	87-003-143-080		COIL,4.7UH K LAL02
	87-A30-087-080	C-FET,2SK2158		L101	87-003-098-080		COIL,2.2UH K LAL02
				R188	87-A00-258-080		RES,M/F 0.22-1W J
DIODE				R189	87-A00-258-080		RES,M/F 0.22-1W J
	87-A40-004-080	ZENER,MTZJ16A		R190	87-A00-258-080		RES,M/F 0.22-1W J
	87-A40-291-080	DIODE,1N4148M (CPT)		R191	87-A00-258-080		RES,M/F 0.22-1W J
	87-A40-269-080	C-DIODE,MC2836		R192	87-A00-258-080		RES,M/F 0.22-1W J
	87-A40-270-080	C-DIODE,MC2838		R193	87-A00-258-080		RES,M/F 0.22-1W J
	87-070-178-090	DIODE,1N5402-BD54		TH51	87-A91-042-080		C-THMS,100K 55001
	87-A40-488-080	DIODE,1SS244		TH52	87-A91-042-080		C-THMS,100K 55001
	87-A40-299-080	ZENER,DZ5.1M		WH101	87-A61-039-010		CONN,19P V WHT 52328
	87-070-274-080	DIODE,1N4003 SEM					
				SPK C.B			
PWB-AMP C.B				C600	87-010-384-040		CAP,E 100-25 M 11L SME
	C101	87-A12-066-080	CAP,E 47-16 SMG	C601	87-010-384-040		CAP,E 100-25 M 11L SME
	C103	87-A12-091-080	CAP,E 10-50 SMG	C602	87-010-384-040		CAP,E 100-25 M 11L SME
	C105	87-010-496-080	CAP,E 3.3-50 M 5L SRE	C603	87-012-278-080		C-CAP,U 2200P-50 B
	C106	87-010-555-080	CAP,E 100-10 GAS	C604	87-012-278-080		C-CAP,U 2200P-50 B
	C107	87-012-286-080	CAP,U 0.01-25 K B	C605	87-A11-174-090		CAP,E 4700-16 M SMG
	C108	87-010-494-080	CAP,E 1-50 M 5L SRE	C606	87-A12-755-000		CAP,E 4700-25 M 85 IV LELON<EZ>
	C110	87-A12-071-080	CAP,E 47-25 SMG	C606	87-A12-829-000		CAP,E 4700-25 M 85 GS<K>
	C111	87-A10-918-080	CAP,E 100-16 SMG	C607	87-A12-317-080		C-CAP,U 0.1-50 Z F
	C112	87-A10-918-080	CAP,E 100-16 SMG	C608	87-A12-317-080		C-CAP,U 0.1-50 Z F
	C113	87-012-286-080	CAP,U 0.01-25 K B<EZ>	C609	87-010-758-080		C-CAP,U 0.068-25 Z F CM/CB
	C114	87-012-284-080	CAP,U 6800P-50 K B	C610	87-010-758-080		C-CAP,U 0.068-25 Z F CM/CB
	C115	87-A12-066-080	CAP,E 47-16 SMG	C611	87-010-759-080		C-CAP,U 0.1-25F
	C116	87-012-284-080	CAP, U 6800P-50	C612	87-010-759-080		C-CAP,U 0.1-25F
	C117	87-012-278-080	C-CAP,U 2200P-50 B	C613	87-010-759-080		C-CAP,U 0.1-25F
	C118	87-012-278-080	C-CAP,U 2200P-50 B	C614	87-010-759-080		C-CAP,U 0.1-25F
	C119	87-A12-085-080	CAP,E 0.33-50 SMG	C615	87-010-759-080		C-CAP,U 0.1-25F
	C120	87-A12-085-080	CAP,E 0.33-50 SMG	C616	87-010-759-080		C-CAP,U 0.1-25F
	C121	87-012-272-080	C-CAP,U 680P-50 K B	CN600	87-009-799-010		CONN,14P H BLK TKC-M
	C122	87-012-272-080	C-CAP,U 680P-50 K B	CN601	87-049-469-010		CONN,4P V WHT EH
	C123	87-A12-440-000	CAP,E 3300-35 M 85 IV LELON	CN602	87-099-407-010		CONN,7P V WHT EH
	C124	87-A12-440-000	CAP,E 3300-35 M 85 IV LELON	J600	87-A60-659-010		TERMINAL,SPKR 4P HSP-134V-05Z
	C125	87-012-273-080	C-CAP,U 820P-50 B	L600	87-003-383-010		COIL,1UH K
	C126	87-012-273-080	C-CAP,U 820P-50 B	L601	87-003-383-010		COIL,1UH K
	C127	87-012-282-080	CAP, U 4700P-50	L602	87-003-098-080		COIL,2.2UH K LAL02
	C128	87-012-282-080	CAP, U 4700P-50	L603	87-003-098-080		COIL,2.2UH K LAL02
	C129	87-012-167-080	C-CAP,U 5P-50 CH	L604	87-003-098-080		COIL,2.2UH K LAL02
	C130	87-012-167-080	C-CAP,U 5P-50 CH	△ PR600	87-026-681-080		PROTECTOR,5A 491SERIES 60V
	C131	87-A12-091-080	CAP,E 10-50 SMG	△ PR601	87-026-681-080		PROTECTOR,5A 491SERIES 60V
	C132	87-A12-071-080	CAP,E 47-25 SMG	△ PR602	87-026-681-080		PROTECTOR,5A 491SERIES 60V
	C135	87-A12-091-080	CAP,E 10-50 SMG				
				FRONT C.B			
C136	87-A12-071-080	CAP,E 47-25 SMG		C300	87-A12-071-080		CAP,E 47-25 SMG

REF. NO.	PART NO.	KANRI NO.	DESCRIPTION	REF. NO.	PART NO.	KANRI NO.	DESCRIPTION
C301	87-012-286-080		C-CAP,U 0.01-25 K B				
C302	87-012-286-080		C-CAP,U 0.01-25 K B				
C303	87-012-286-080		C-CAP,U 0.01-25 K B				
C304	87-012-286-080		C-CAP,U 0.01-25 K B				
C305	87-012-286-080		C-CAP,U 0.01-25 K B				
C306	87-012-286-080		C-CAP,U 0.01-25 K B				
CNA301	88-805-072-090		CONN ASSY,7P 2.0 200MM				
CNA302	88-805-020-790		CONN ASSY,2P 70MM				
CNA303	88-805-020-790		CONN ASSY,2P 70MM				
D302	87-A40-317-080		LED,SLR-342VCT31 RED				
D303	87-A40-640-010		LED,SELU1E10CXM BLUE-EF				
D304	87-A40-640-010		LED,SELU1E10CXM BLUE-EF				
S301	87-A90-696-080		SW,TACT TS2103-03-430				
S302	87-A90-696-080		SW,TACT TS2103-03-430				
S303	87-A90-696-080		SW,TACT TS2103-03-430				
S304	87-A90-696-080		SW,TACT TS2103-03-430				
S305	87-A90-696-080		SW,TACT TS2103-03-430				
SW300	87-A92-202-010		SW,RTRY RE012302PVB25 FUNC				
SW301	87-A92-203-010		SW,RTRY RE012305PVB25 JOG				
HP C.B							
C617	87-012-280-080		C-CAP,U 3300P-50 K B				
C618	87-012-280-080		C-CAP,U 3300P-50 K B				
CNA501	8B-CE1-622-010		CONN ASSY,7P 240MM				
J501	87-A60-420-010		JACK,3.5 ST (MSC)				
				LED-L C.B			
				C701	87-012-286-080		C-CAP,U 0.01-25 K B
				CN702	87-A60-619-010		CONN,2P V 2MM JMT
				D700	87-A40-640-010		LED,SELU1E10CXM BLUE-EF
				LED-R C.B			
				C702	87-012-286-080		C-CAP,U 0.01-25 K B
				CN703	87-A60-619-010		CONN,2P V 2MM JMT
				D701	87-A40-640-010		LED,SELU1E10CXM BLUE-EF
				AC C.B			
				△ C404	87-A10-479-080		CAP,CER 2200P-250 M E KH
				CN401	87-A60-538-010		CONN,5P H TUC-P05X-B1
				CN402	87-A60-619-010		CONN,2P V 2MM JMT
				△ PT401	8B-NF9-665-010		PT,SUB BNF E (TAM)
				△ PT403	8B-CE1-613-010		PT, EZ
				△ RY401	87-A90-976-010		RELAY,AC12V SDT-S-112LMR
				△ TM401	87-A60-317-010		TERMINAL, 1P MSC
				△ TM402	87-A60-317-010		TERMINAL, 1P MSC

チップ抵抗部品コード/CHIP RESISTOR PART CODE

チップ抵抗部品コードの成り立ち

Chip Resistor Part Coding



A
抵抗部品コード
Resistor Code

桁表示
Figure
抵抗値
Value of resistor

チップ抵抗
Chip resistor

容量 Wattage	種類 Type	許容誤差 Tolerance	記号 Symbol	寸法/Dimensions (mm)			抵抗コード : A Resistor Code : A	
				外形/Form	L	W		t
1/16W	1005	± 5%	CJ		1.0	0.5	0.35	104
1/16W	1608	± 5%	CJ		1.6	0.8	0.45	108
1/10W	2125	± 5%	CJ		2	1.25	0.45	118
1/8W	3216	± 5%	CJ		3.2	1.6	0.55	128

TRANSISTOR ILLUSTRATION



E C B

CC5551
KTA1266GR



E C B

2SD655E



B C E

2SD2025



B C E

2SB1344

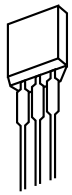

E C B

2SC4115SRS

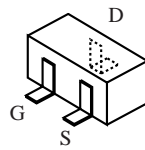

2SK2158

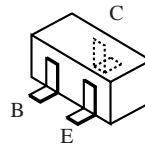

2SA1235F
2SA1514K(S)
2SC3052F
CMBT5551
RT1P141C
RT1P441C

32	31	30	29	28	27	26	25	24	23	22	21	20	19	18	17	16	15	14	13	12	11	10	9	8	7	6	5	4	3	2	1
----	----	----	----	----	----	----	----	----	----	----	----	----	----	----	----	----	----	----	----	----	----	----	---	---	---	---	---	---	---	---	---

A
B
C
D
E
F
G
H
I
J
K
L
M
N
O
P
Q
R
S
T
U

C FRONT C.B

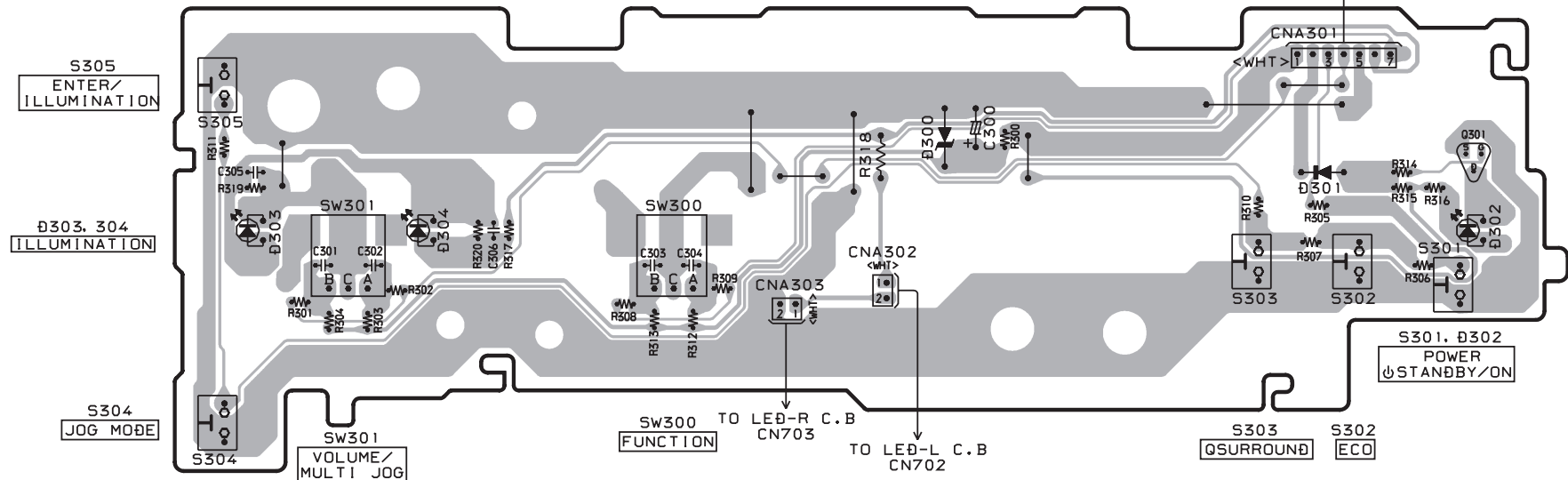

G AC C.B

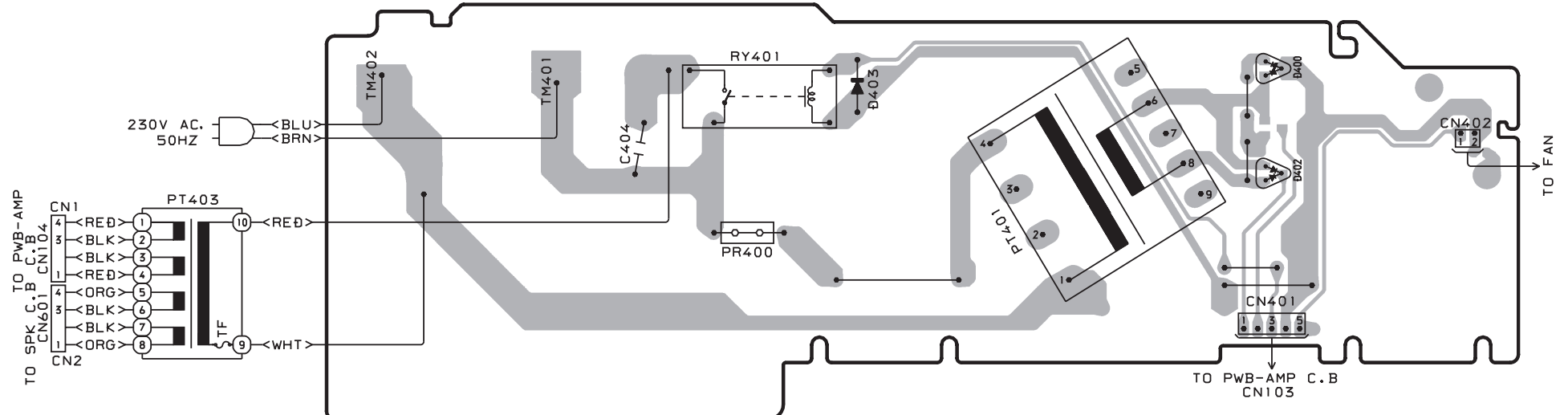

F LED-R C.B

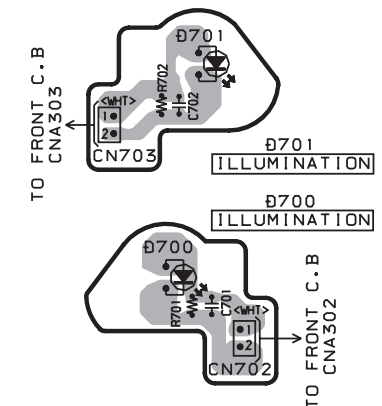

B SPK C.B

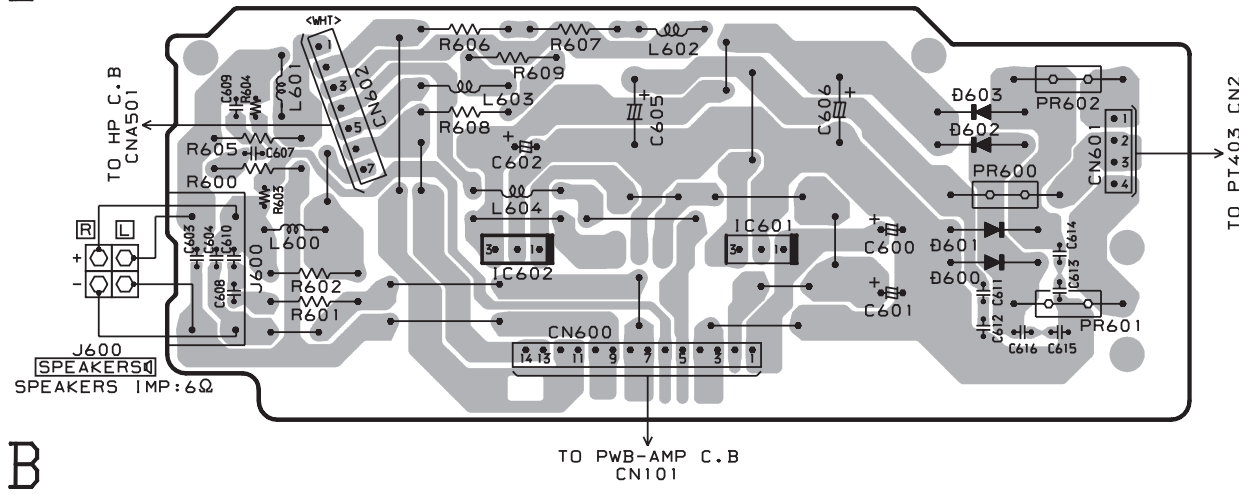

E LED-L C.B

SCHEMATIC DIAGRAM (PWB-AMP/SPK/FRONT/HP/LED-L/LED-R/AC)

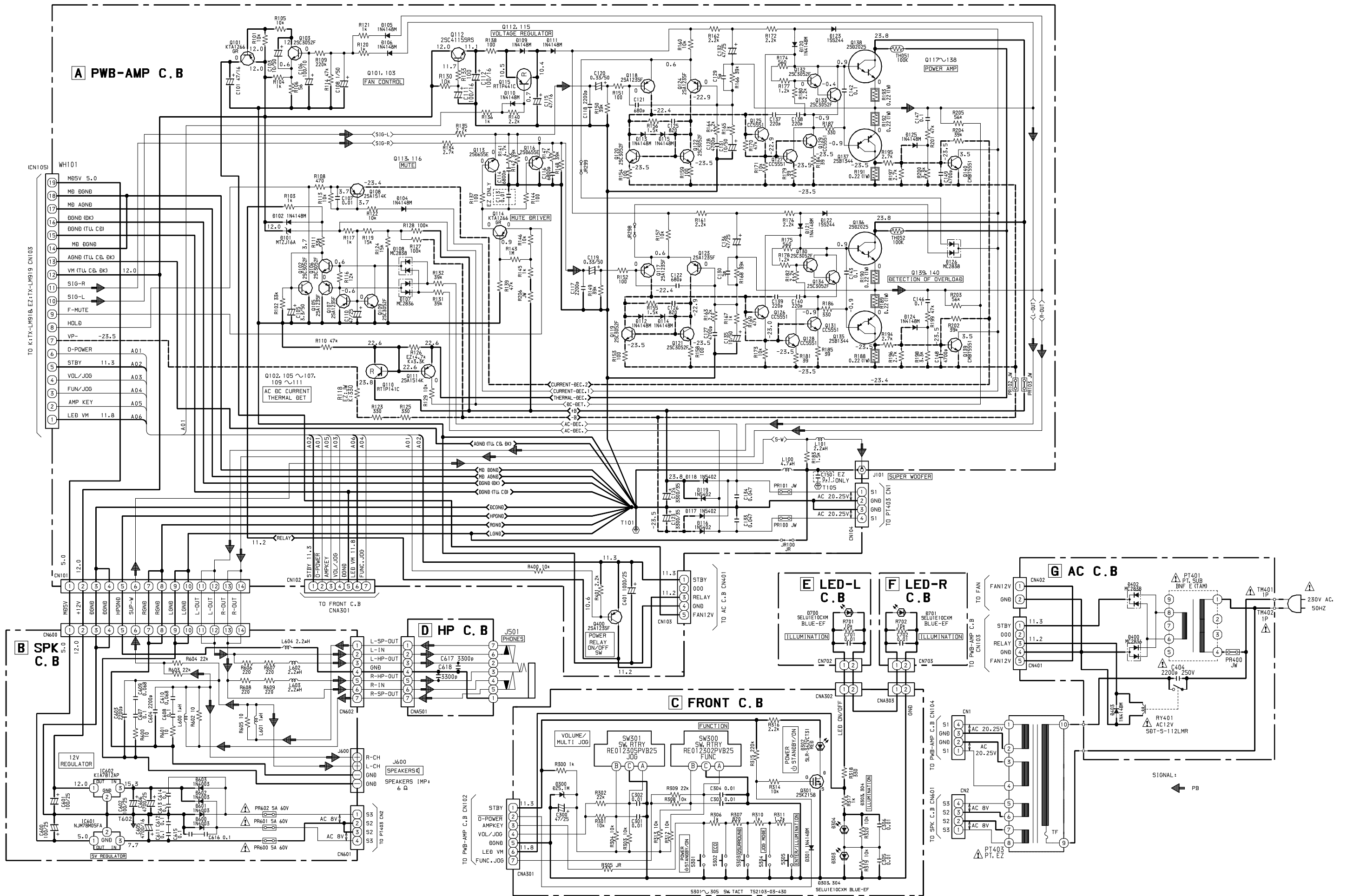

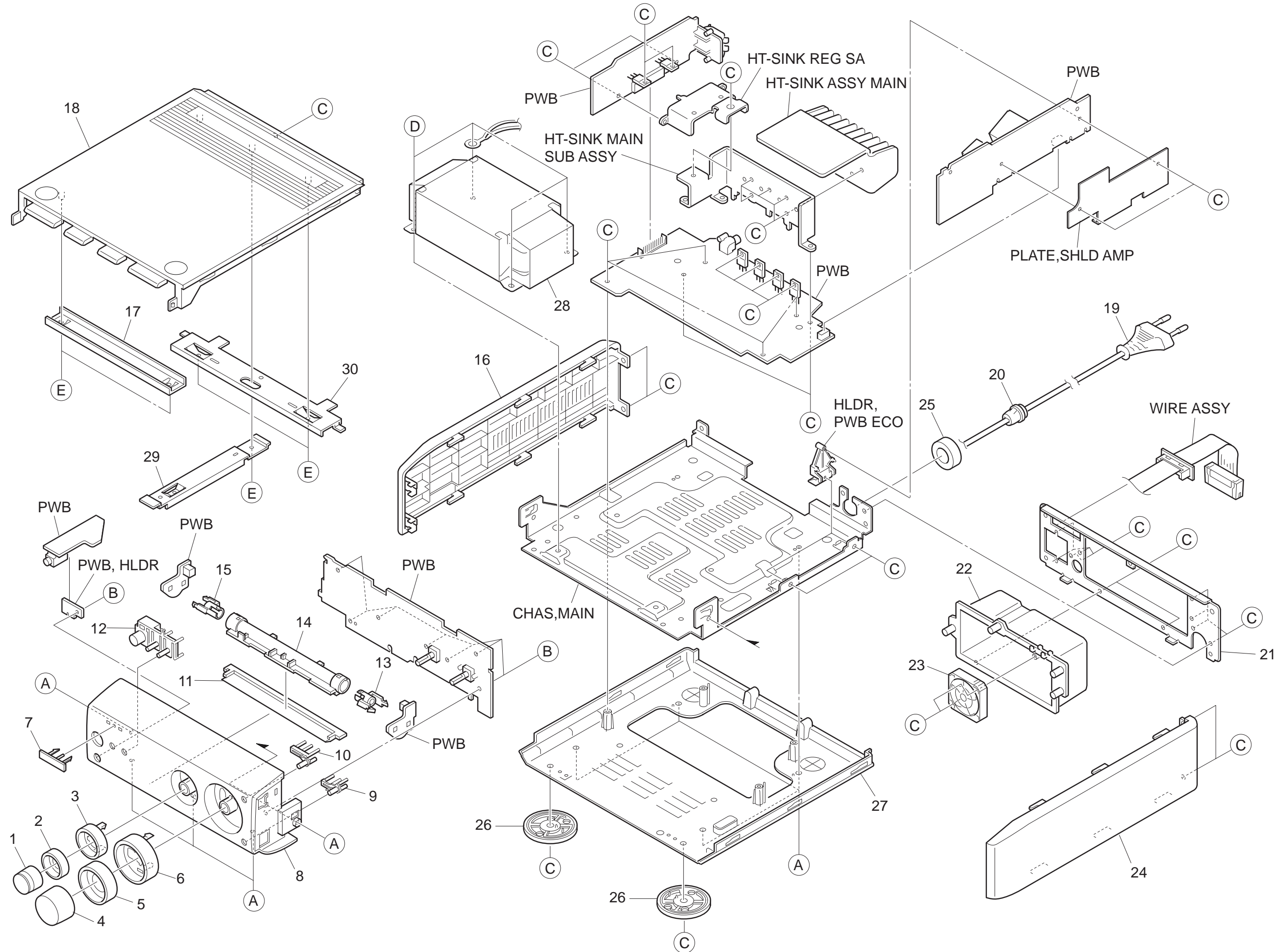

MECHANICAL PARTS LIST 1 / 1 <EZ>

REF. NO.	PART NO.	KANRI NO.	DESCRIPTION
1	8B-CE1-011-010		KNOB, RTRY FUN
2	8B-CE1-015-010		LENS, FUN
3	8B-CE1-006-010		RING, FUN
4	8B-CE1-012-010		KNOB, RTRY VOL
5	8B-CE1-008-010		REFLECTOR, VOL
6	8B-CE1-007-010		RING, VOL
7	8Z-CC3-007-010		BADGE, AIWA 27.5 ABS SIL
8	8B-CE1-023-010		CABI, FR AMP EZ
9	8B-CE1-014-010		KEY, JOG MODE
10	8B-CE1-013-010		KEY, ENTER
11	8B-CE1-018-010		REFLECTOR, FR
12	8B-CE1-025-010		KEY ASSY, POWER
13	8Z-CE3-204-010		GUIDE, LED R
14	8B-CE1-208-010		GUIDE, LED CNT
15	8Z-CE3-203-010		GUIDE, LED L
16	8B-CE1-002-010		PANEL, SIDE L AMP
17	8Z-CE3-208-010		PLATE, TOP AMP
18	8B-CE1-005-010		PANEL, TOP AMP
△	19	87-A80-157-010	AC CORD ASSY, E BLK CC
20	87-085-185-010		BUSHING, AC CORD (E)
21	8B-CE1-019-010		PANEL, REAR AMP
22	8B-CE1-017-010		COVER, FAN
23	8B-CL5-616-010		FAN, F410T-12LC-200MM
24	8B-CF1-006-010		PANEL, SIDE R
25	87-003-317-010		F-BEAD, F0H2515-LG7
26	8B-CE1-016-010		FOOT, DIA40 H4
△	27	8B-CE1-004-010	COVER, CHAS MAIN
28	8B-CE1-613-010		PT, EZ
29	8B-CE1-212-010		PLATE, TOP A
30	8B-CE1-213-010		PLATE, TOP B
A	87-591-095-410		TAPPING SCREW, QIT+3-8 (GLD)
B	87-B10-294-010		BVT2+2.6-8
C	87-067-703-010		TAPPING SCREW, BVT2+3-10
D	87-067-586-010		TAPPING SCREW, BVT2+4-8
E	87-067-684-010		BVT2+2.6-6 W/O SLOT

COLOR NAME TABLE

Basic color symbol	Color	Basic color symbol	Color	Basic color symbol	Color
B	Black	C	Cream	D	Orange
G	Green	H	Gray	L	Blue
LT	Transparent Blue	N	Gold	P	Pink
R	Red	S	Silver	ST	Titan Silver
T	Brown	V	Violet	W	White
WT	Transparent White	Y	Yellow	YT	Transparent Yellow
LM	Metallic Blue	LL	Light Blue	GT	Transparent Green
LD	Dark Blue	DT	Transparent Orange	GM	Metallic Green
YM	Metallic Yellow	DM	Metallic Orange	PT	Transparent Pink
LA	Aqua Blue	GL	Light Green	HT	Transparent Gray

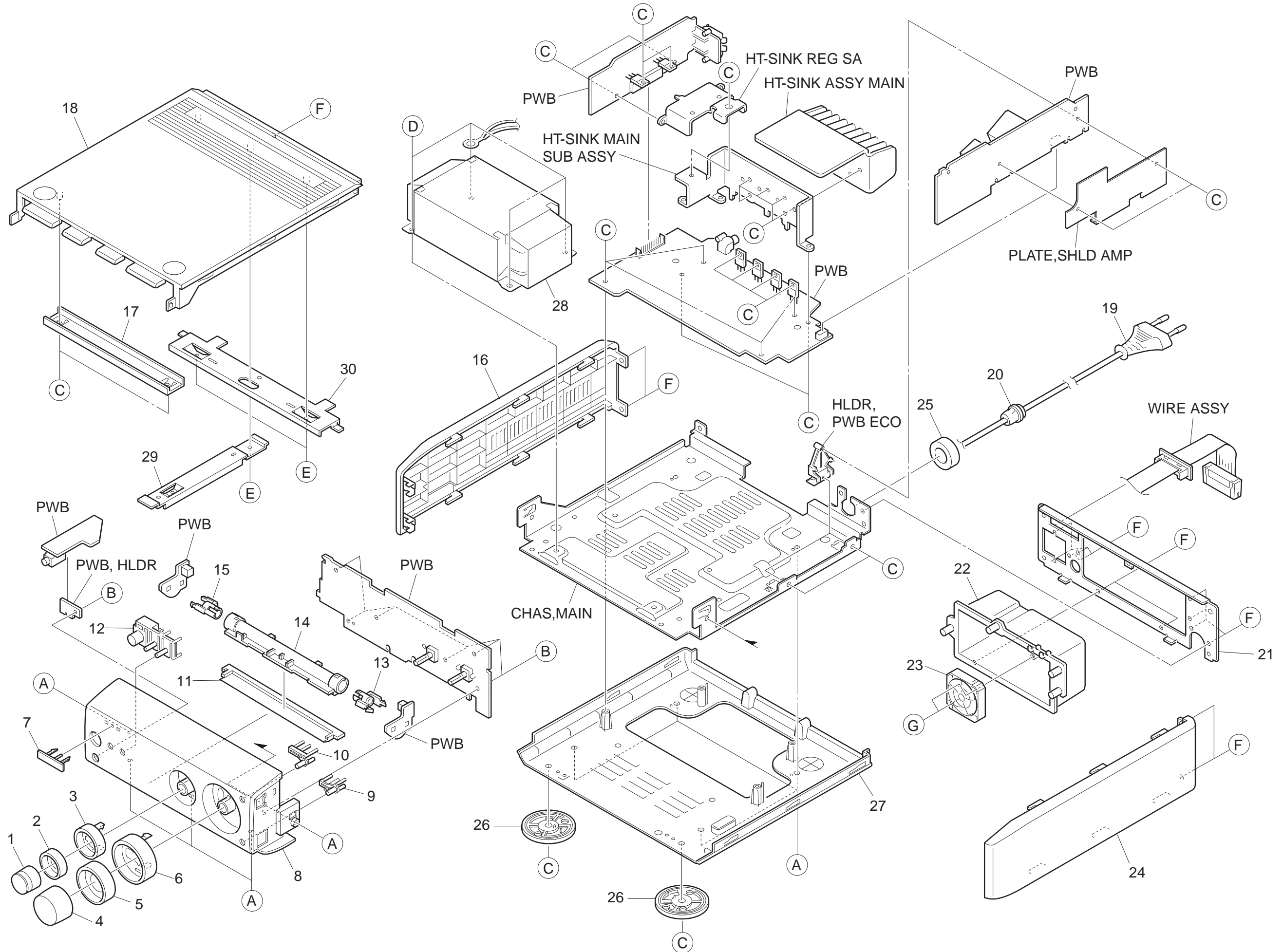

MECHANICAL PARTS LIST 1 / 1 <K>

REF. NO.	PART NO.	KANRI NO.	DESCRIPTION
1	8B-CE1-011-010		KNOB, RTRY FUN
2	8B-CE1-015-010		LENS, FUN
3	8B-CE1-006-010		RING, FUN
4	8B-CE1-012-010		KNOB, RTRY VOL
5	8B-CE1-008-010		REFLECTOR, VOL
6	8B-CE1-007-010		RING, VOL
7	8Z-CC3-007-010		BADGE, AIWA 27.5 ABS SIL
8	8B-CE1-001-010		CABI, FR AMP
9	8B-CE1-014-010		KEY, JOG MODE
10	8B-CE1-013-010		KEY, ENTER
11	8B-CE1-018-010		REFLECTOR, FR
12	8B-CE1-025-010		KEY ASSY, POWER
13	8Z-CE3-204-010		GUIDE, LED R
14	8B-CE1-208-010		GUIDE, LED CNT
15	8Z-CE3-203-010		GUIDE, LED L
16	8B-CE1-002-010		PANEL, SIDE L AMP
17	8Z-CE3-208-010		PLATE, TOP AMP
18	8B-CE1-005-010		PANEL, TOP AMP
△	19	87-A80-157-010	AC CORD ASSY, E BLK CC
20	87-085-185-010		BUSHING, AC CORD (E)
21	8B-CE1-019-010		PANEL, REAR AMP
22	8B-CE1-017-010		COVER, FAN
23	8B-CL5-616-010		FAN, F410T-12LC-200MM
24	8B-CF1-006-010		PANEL, SIDE R
25	87-003-317-010		F-BEAD, F0H2515-LG7
26	8B-CE1-016-010		FOOT, DIA40 H4
△	27	8B-CE1-004-010	COVER, CHAS MAIN
28	8B-CE1-613-010		PT, EZ
29	8B-CE1-212-010		PLATE, TOP A
30	8B-CE1-213-010		PLATE, TOP B
A	87-591-095-410		TAPPING SCREW, QIT+3-8 (GLD)
B	87-B10-294-010		BVT2+2.6-8
C	87-067-703-010		TAPPING SCREW, BVT2+3-10
D	87-067-586-010		TAPPING SCREW, BVT2+4-8
E	87-067-684-010		BVT2+2.6-6 W/O SLOT
F	87-067-761-010		BVT2+3-10 BLK
G	87-751-096-410		BVT2+3-10 W/O SLOT

COLOR NAME TABLE

Basic color symbol	Color	Basic color symbol	Color	Basic color symbol	Color
B	Black	C	Cream	D	Orange
G	Green	H	Gray	L	Blue
LT	Transparent Blue	N	Gold	P	Pink
R	Red	S	Silver	ST	Titan Silver
T	Brown	V	Violet	W	White
WT	Transparent White	Y	Yellow	YT	Transparent Yellow
LM	Metallic Blue	LL	Light Blue	GT	Transparent Green
LD	Dark Blue	DT	Transparent Orange	GM	Metallic Green
YM	Metallic Yellow	DM	Metallic Orange	PT	Transparent Pink
LA	Aqua Blue	GL	Light Green	HT	Transparent Gray

MODEL NO.

DX-LM918

ELECTRICAL MAIN PARTS LIST

REF. NO.	PART NO.	KANRI NO.	DESCRIPTION	REF. NO.	PART NO.	KANRI NO.	DESCRIPTION
IC				C748	87-012-199-080		C-CAP,U 220P-50 J CH
				C749	87-012-284-080		CAP, U 6800P-50
	87-A20-547-010		C-IC, CXA1992AR	C750	87-010-759-080		C-CAP,U, 0.1-25F
	87-A20-546-010		C-IC, CXD2589Q	C754	87-012-286-080		CAP, U 0.01-25
	87-A20-445-010		IC, BA5936S	C755	87-A12-068-080		CAP,E 470-16 SMG
	87-017-917-080		IC, BU4066BCF				
	87-001-792-080		IC, NJM2100M	C756	87-A12-319-080		C-CAP,U 0.1-25 K B
				C757	87-A11-049-080		C-CAP,U 1-6.3 K B
	87-017-760-080		IC, M51943BML	C758	87-010-560-040		CAP,E 10-50 M 5L SRE
	87-017-825-010		IC, GP1F32T	C759	87-010-759-080		C-CAP,U, 0.1-25F
				C760	87-A10-189-040		CAP,E 220-10 M 5L
TRANSISTOR				C761	87-012-180-080		C-CAP,U 22P-50 CH
				C762	87-010-553-040		CAP,E 47-16 GAS
	87-026-451-080		TR, 2SA933SR	C763	87-012-286-080		CAP, U 0.01-25
	89-113-184-080		TR, 2SA1318T	C764	87-010-759-080		C-CAP,U, 0.1-25F
	87-A30-273-040		C-TR, DTC124EKA	C765	87-010-981-040		CAP,E 22-35 5L SRE
	87-A30-047-080		TR, CSD655E				
DIODE				C766	87-012-286-080		CAP, U 0.01-25
				C767	87-012-197-080		C-CAP,U 150P-50 CH
	87-020-465-080		DIODE, 1SS133	C768	87-012-197-080		C-CAP,U 150P-50 CH
	87-A40-747-080		ZENER, UZ5.1BSB	C769	87-A10-759-040		CAP,E 330-6.3 SRM
				C770	87-012-286-080		CAP, U 0.01-25
MAIN C.B				C771	87-012-272-080		C-CAP,U 680P-50 B
C701	87-010-497-040		CAP,E 4.7-35 M 5L SRE	C772	87-012-272-080		C-CAP,U 680P-50 B
C702	87-012-164-080		C-CAP,U 2P-50 C CH	C773	87-012-172-080		C-CAP,U 10P-50 D CH
C704	87-A11-070-080		C-CAP,U 0.033-16 K B	C774	87-012-172-080		C-CAP,U 10P-50 D CH
C705	87-A11-070-080		C-CAP,U 0.033-16 K B	C776	87-012-172-080		C-CAP,U 10P-50 D CH
C706	87-A11-070-080		C-CAP,U 0.033-16 K B				
				C777	87-010-560-040		CAP,E 10-50 GAS
C707	87-A11-070-080		C-CAP,U 0.033-16 K B	C778	87-010-560-040		CAP,E 10-50 GAS
C710	87-A11-049-080		C-CAP,U 1-6.3 K B	C781	87-012-276-080		C-CAP,U 1500P-50 K B
C711	87-A10-504-080		C-CAP,U 0.047-16 K B	C782	87-012-276-080		C-CAP,U 1500P-50 K B
C712	87-A10-504-080		C-CAP,U 0.047-16 K B	C783	87-012-286-080		CAP, U 0.01-25
C713	87-012-270-080		C-CAP,U 470P-50				
				C786	87-010-759-080		C-CAP,U, 0.1-25 Z F
C714	87-010-785-080		C-CAP,U 0.015-25BK	C787	87-012-195-080		C-CAP,U 100P-50 J CH
C715	87-A10-504-080		C-CAP,U 0.047-16 K B	C788	87-012-274-080		C-CAP,U 1000P-50 K B
C716	87-A10-504-080		C-CAP,U 0.047-16 K B	C789	87-012-195-080		C-CAP,U 100P-50 J CH
C717	87-010-759-080		C-CAP,U, 0.1-25F	C791	87-012-188-080		C-CAP,U 47P-50 J CH
C718	87-010-787-080		CAP, U 0.022-25				
				C800	87-012-759-080		C-CAP,U 0.1-25 Z F
C719	87-010-555-040		CAP,E 100-10 M 5L SRE	C801	87-012-282-080		CAP, U 4700P-50
C720	87-010-981-040		CAP,E 22-35 M 5L SRE	C803	87-010-759-080		C-CAP,U, 0.1-25F
C721	87-010-555-040		CAP,E 100-10 M 5L SRE	C805	87-012-195-080		C-CAP,U 100P-50CH
C722	87-A12-319-080		C-CAP,U 0.1-25 K B	C806	87-012-195-080		C-CAP,U 100P-50CH
C723	87-A12-319-080		C-CAP,U 0.1-25 K B				
				C807	87-012-195-080		C-CAP,U 100P-50CH
C724	87-A12-319-080		C-CAP,U 0.1-25 K B	C808	87-012-195-080		C-CAP,U 100P-50CH
C725	87-A12-319-080		C-CAP,U 0.1-25 K B	C810	87-012-141-080		C-CAP,U 0.22-16 Z F
C726	87-012-278-080		C-CAP,U 2200P-50 B	C811	87-A10-189-040		CAP,E 220-10
C727	87-010-494-040		CAP,E 1-50 M 5L SRE	C812	87-012-286-080		CAP, U 0.01-25
C728	87-012-269-080		C-CAP,U 390P-50 B				
				C815	87-A10-730-080		CAP,E 1000-16 SMG
C729	87-010-555-040		CAP,E 100-10 M 5L SRE	C817	87-010-981-040		CAP,E 22-35 5L SRE
C730	87-012-286-080		CAP, U 0.01-25	C820	87-010-757-080		CAP, CHIP 0.047-25 Z F
C731	87-010-785-080		C-CAP,U 0.015-25BK	C860	87-A11-049-080		C-CAP,U 1-6.3 K B
C732	87-012-276-080		C-CAP,U 1500P-50 K B	CN701	87-A61-040-010		CONN,20P V WHT 52328
C733	87-010-555-040		CAP,E 100-10 M 5L SRE				
				CN702	87-099-564-010		CONN,4P V TUC-P4P-B1
C734	87-010-555-040		CAP,E 100-10 M 5L SRE	CN703	87-A60-586-010		CONN,4P V FE
C735	87-010-497-040		CAP,E 4.7-35 M 5L SRE	CN704	87-A60-130-010		CONN,5P V FE
C736	87-012-286-080		CAP, U 0.01-25	CN706	87-A60-131-010		CONN,6P V FE
C737	87-A10-189-040		CAP,E 220-10 M 5L	CN707	87-A60-424-010		CONN,16P V TOC-B
C739	87-012-280-080		CAP, U 3300P-50				
				CNA701	8Z-CX3-607-010		CONN ASSY,20P 52305-2011
C741	87-A12-319-080		C-CAP,U 0.1-25 K B	FC703	88-904-201-110		FF-CABLE,4P 1.25
C743	87-012-286-080		CAP, U 0.01-25	FC704	88-905-301-110		FF-CABLE,5P 300M
C744	87-A10-730-080		CAP,E 1000-16 SMG	FC706	88-906-151-110		FF-CABLE,6P 1.25
C745	87-A10-504-080		C-CAP,U 0.047-16 K B	FC707	8B-CX1-621-010		FF-CABLE,16P 1.0 200M
C746	87-012-286-080		CAP, U 0.01-25				
				JW727	87-003-152-080		COIL,100UH J LAL02
C747	87-A11-059-080		C-CAP,U 0.47-10 K B	JW729	87-008-372-080		FILTER, EMI BL01 RN1
				L701	87-003-102-080		COIL,10UH J LAL02
				L702	87-003-102-080		COIL,10UH J LAL02
				L703	87-008-372-080		FILTER, EMI BL01 RN1

REF. NO.	PART NO.	KANRI NO.	DESCRIPTION	REF. NO.	PART NO.	KANRI NO.	DESCRIPTION
L710	87-003-102-080		COIL,10UH J LAL02	LED-L C.B			
L801	87-008-372-080		FILTER, EMI BL01 RN1				
R700	87-022-255-080		C-RES,U47K-1/16WF	C792	87-012-286-080		CAP, U 0.01-25
R701	87-022-255-080		C-RES,U47K-1/16WF	CN705	87-A60-619-010		CONN,2P V 2MM JMT
R705	87-022-227-080		C-RES,U 3.3K-1/16W F	D2	87-A40-678-010		LED,SELU1E10CXM BLUE-DEF
R706	87-022-227-080		C-RES,U 3.3K-1/16W F	LED-R C.B			
R707	87-022-227-080		C-RES,U 3.3K-1/16W F				
R708	87-022-227-080		C-RES,U 3.3K-1/16W F				
R712	87-022-249-080		C-RES U27K 1/16W F	C793	87-012-286-080		CAP, U 0.01-25
R713	87-022-249-080		C-RES U27K 1/16W F	CN709	87-A60-619-010		CONN,2P V 2MM JMT
R714	87-022-257-080		C-RES,U 56K 1/16W F	D1	87-A40-678-010		LED,SELU1E10CXM BLUE-DEF
R715	87-022-257-080		C-RES,U 56K 1/16W F				
R789	87-008-372-080		FILTER, EMI BL01 RN1	CD LOAD C.B			
R797	87-003-152-080		COIL,100UH J LAL02				
X701	87-A70-005-080		VIB,XTAL 33.8688MHZ HC-49/U03	CON6	87-099-210-010		CONN,5P H BLK 6216
				M1	87-045-305-010		MOTOR,RF-500TB
				SW1	87-036-110-010		SW, MICRO SPPB62
				SW2	87-036-110-010		SW, MICRO SPPB62
SUB C.B				CD DRIVE C.B			
C814	87-012-286-080		CAP, U 0.01-25				
CN711	87-099-553-010		CONN,4P H TUC-P	CON3	87-A60-086-010		CONN,6P H 6216
				M20	87-045-358-010		MOT,RF-310TA 43
				M21	87-045-356-010		MOT,RF-310TA 30
				SW1	87-A90-042-010		SW,LEAF MSW-17310MVPO
FRONT C.B							
CN708	87-A60-586-010		CONN,4P V FE				
CNA705	88-805-020-790		CONN ASSY,2P 70MM				
CNA709	88-805-021-090		CONN ASSY,2P				
R833	87-022-283-080		CHIP RES U820-1/16W				
R834	87-022-283-080		CHIP RES U820-1/16W				
R835	87-022-215-080		CHIP RESISTOR U 1K-1/16W F				
R836	87-022-217-080		C-RES,U 1.2K-1/16W F				
R837	87-022-217-080		C-RES,U 1.2K-1/16W F				
R838	87-022-219-080		C-RES,U 1.5K-1/16W F				
R839	87-022-223-080		CHIP RES 2.2K 1/16W F				
S801	87-A90-696-080		SW,TACT TS2103-03-430				
S802	87-A90-696-080		SW,TACT TS2103-03-430				
S803	87-A90-696-080		SW,TACT TS2103-03-430				
S804	87-A90-696-080		SW,TACT TS2103-03-430				
S805	87-A90-696-080		SW,TACT TS2103-03-430				
S806	87-A90-696-080		SW,TACT TS2103-03-430				
S807	87-A90-696-080		SW,TACT TS2103-03-430				
S808	87-A90-696-080		SW,TACT TS2103-03-430				

○チップ抵抗部品コード/CHIP RESISTOR PART CODE

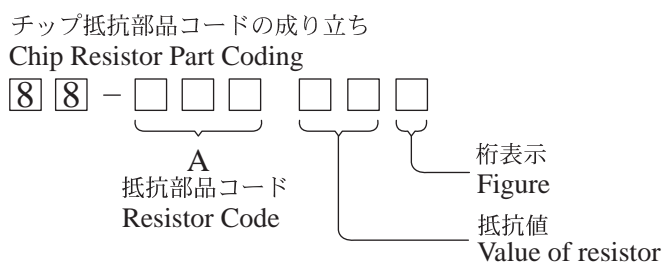

チップ抵抗
Chip resistor

容量 Wattage	種類 Type	許容誤差 Tolerance	記号 Symbol	寸法/Dimensions (mm)			抵抗コード : A Resistor Code : A	
				外形/Form	L	W		t
1/16W	1005	± 5%	CJ		1.0	0.5	0.35	104
1/16W	1608	± 5%	CJ		1.6	0.8	0.45	108
1/10W	2125	± 5%	CJ		2	1.25	0.45	118
1/8W	3216	± 5%	CJ		3.2	1.6	0.55	128

TRANSISTOR ILLUSTRATION

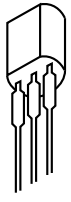

E C B

CSD655E

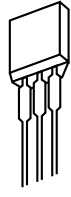

E C B

2SA933SR



E C B

2SA1318T

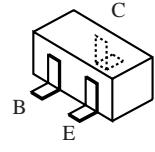

C
B
E

DTC124EKA

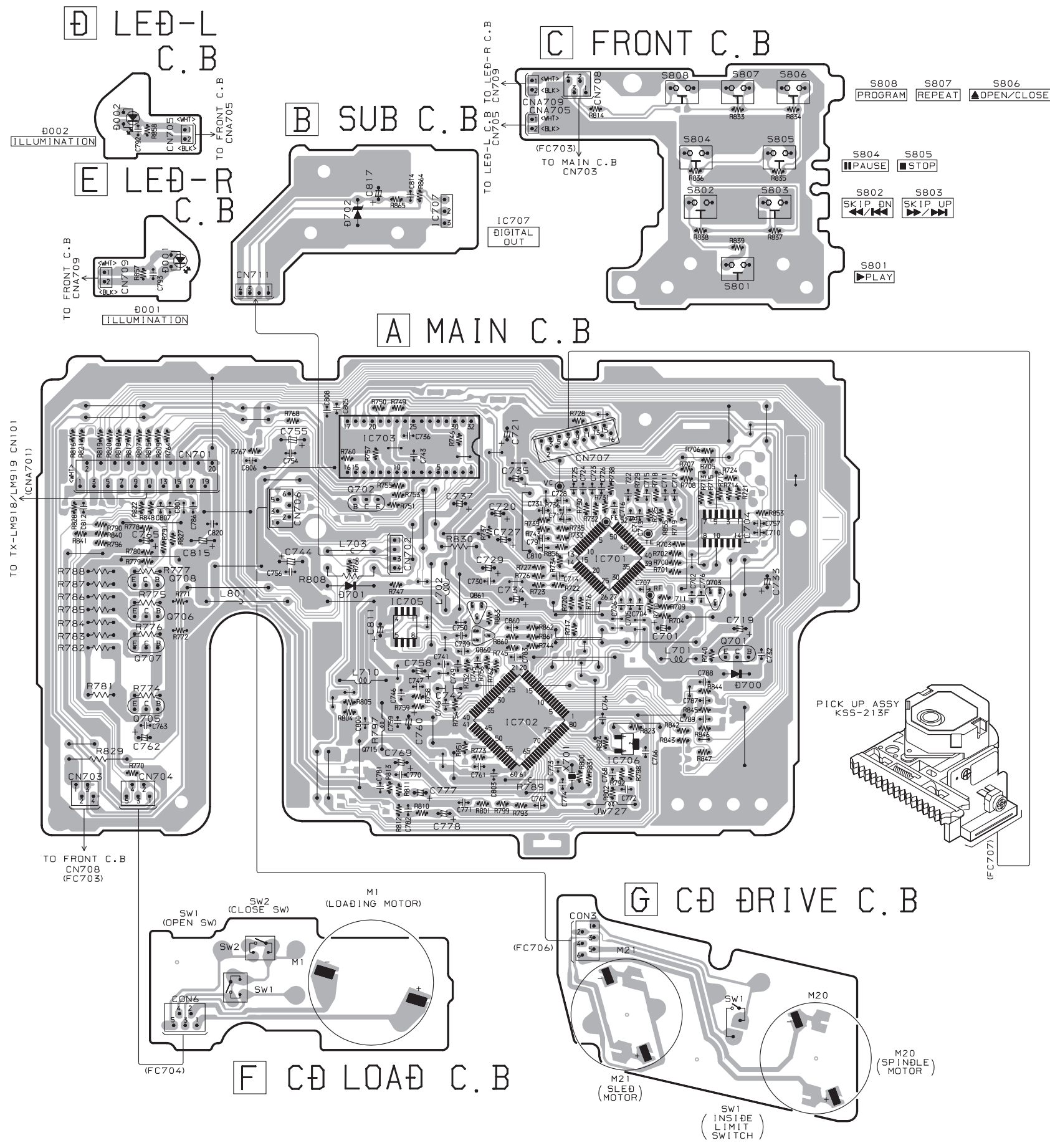

SCHEMATIC DIAGRAM (MAIN/SUB/FRONT/LED-L/LED-R/CD LOAD/CD DRIVE)

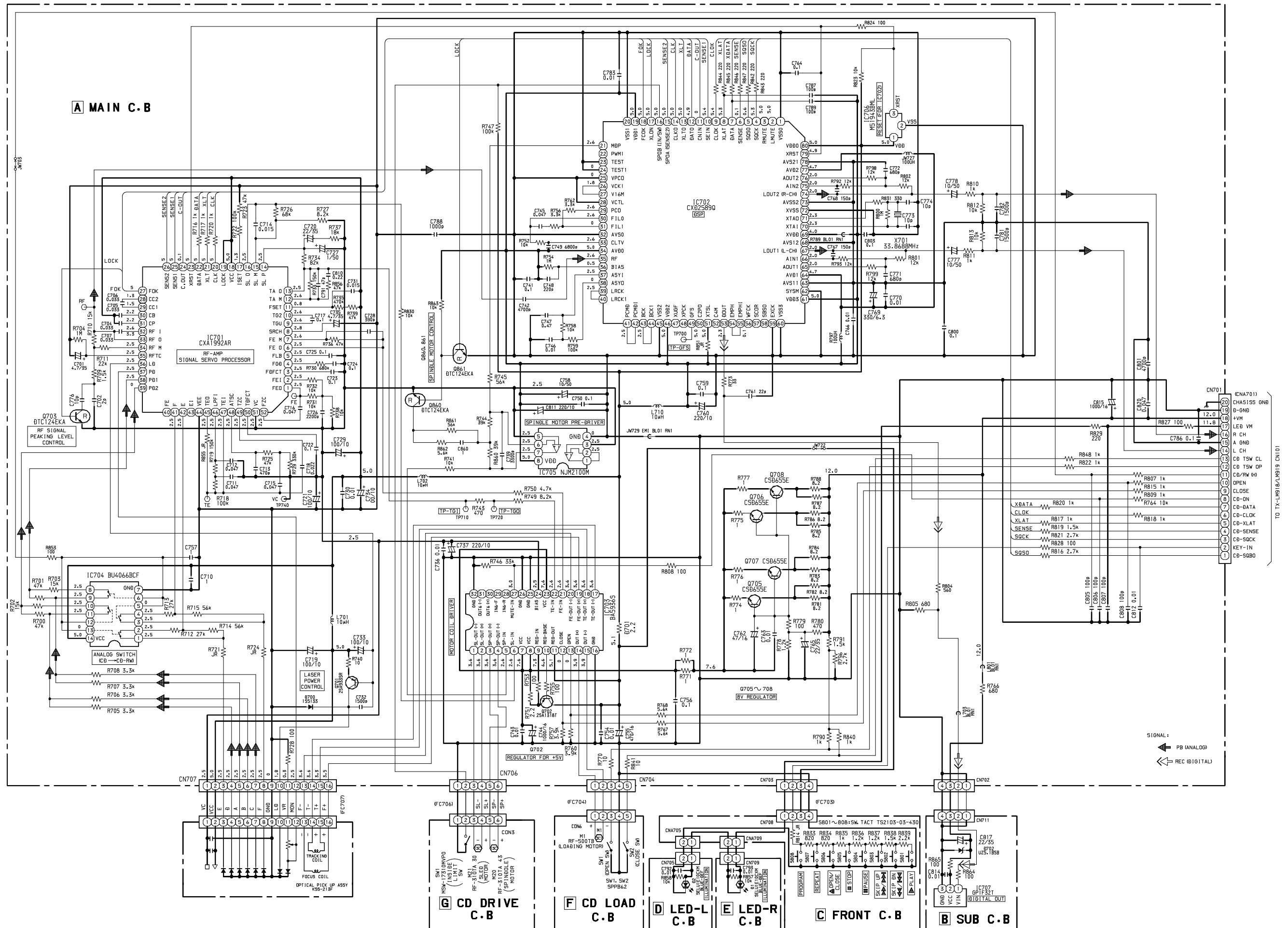

IC BLOCK DIAGRAM

IC, BA5936S

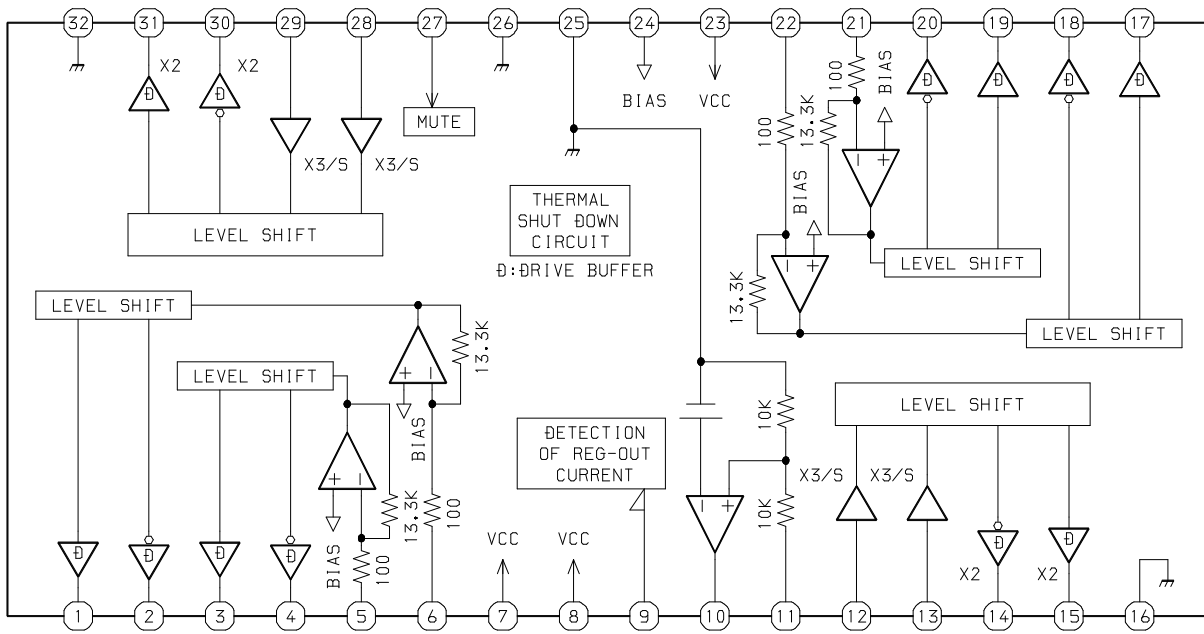

IC DESCRIPTION

IC, CXA1992AR

Pin No.	Pin Name	I/O	Description
1	FEO	O	Output terminal for focus error amplifier. Internally connected to window comparator input for bias condition.
2	FEI	I	Input terminal for focus error.
3	DFDCT	I	Capacitor connection terminal for time constant used when there is defect.
4	FGD	I	This pin is connected to GND via capacitor when high frequency gain of the focus servo is attenuated.
5	FLB	I	This is a pin where the time constant is externally connected to raise the low frequency gain of the focus servo.
6	FE O	O	Focus drive output.
7	FE M	I	Focus amplifier inverted input pin.
8	SRCH	I	This is a pin where the time constant is externally connected to generate the focus search waveform.
9	TGU	I	This is a pin where the selection time constant is externally connected to set the tracking servo the high frequency gain.
10	TG2	I	This is a pin where the selection time constant is externally connected to set the tracking high frequency gain.
11	FSET	I	Pin for setting peak of the phase compensator of the focus tracking.
12	TA M	I	Tracking amplifier inverted input pin.
13	TA O	O	Tracking drive output.
14	SL P	I	Sled amplifier non-inverted input pin.
15	SL M	I	Sled amplifier inverted input pin.
16	SL O	O	Sled drive output.
17	ISET	I	The current which determines height of the focus search, track jump and sled kick is input with external resistance connected.
18	VCC	I	Power supply.
19	LOCK	I	“L” setting starts sled disorder-prevention circuit. (Connected to VCC)
20	CLK	I	Clock input for serial data transfer from CPU.
21	XLT	I	Latch input from CPU.
22	DATA	I	Serial data input from CPU.
23	XRST	I	Reset system at “L” setting.
24	C.OUT	O	Signal output for track number counting.
25	SENS1	O	FZC, DFCT1, TZC, BALH, TGH, FOH, or ATSC is output depending on the command from CPU.
26	SENS2	O	DFCT2, MIRR, BALL, TGL or FOL is output depending on the command from CPU.
27	FOK	O	Output terminal for focus OK comparator.
28	CC2	I	Input pin where the DEFECT bottom hold output is capacitance coupled.
29	CC1	O	DEFECT bottom-hold output terminal. Internally connected to interruption comparator input.
30	CB	I	Connection terminal for DEFECT bottom-hold capacitor.
31	CP	I	Connection terminal for MIRR hold-capacitor. Anti-reverse input terminal for MIRR comparator.

Pin No.	Pin Name	I/O	Description
32	RF I	I	Input terminal by capacity combination of RF summing amplifier.
33	RF O	O	Output terminal of RF summing amplifier. Checkpoint of Eye pattern.
34	RF M	I	Anti-reverse input terminal for RF summing amplifier. The gain of RF amplifier is decided by the connection resistance between RF M and RF O terminals.
35	RFTC	I	This is a pin where the selection time constant is externally connected to control the RF level.
36	LD	O	APC amplifier output terminal.
37	PD	I	APC amplifier input terminal.
38, 39	PD1, PD2	I	RFI-V amplifier inverted input pin. These pins are connected to the A+C and B+C pins of the optical pickup, receiving by currents input.
40	FE	I/O	Bias adjustment pin of the focus error amplifier. (Not used)
41, 42	F, E	I	F and EIV amplifier inverted input pins. These pins are connected to the F and E of the optical pickup, receiving by current input.
43	EI	—	Gain adjustment pin of the I-V amplifier E. (When not in use of BAL automatic adjustment). (Not used)
44	VEE	—	GND connection pin.
45	TEO	O	Output terminal for tracking-error amplifier. Output E-F signal.
46	LPFI	I	BAL adjustment comparator input pin. (Input through LPF from TEO)
47	TEI	I	Input terminal for tracking error.
48	ATSC	I	Window-comparator input terminal for detecting ATSC.
49	TZC	I	Input terminal for tracking-zero cross comparator.
50	TDFCT	I	Capacitor connection pin for the time constant used when there is defect.
51	VC	O	Output terminal for DC voltage reduced to half of VCC+VEE.
52	FZC	I	Input terminal for focus-zero cross comparator.

IC, CXD2589Q

Pin No.	Pin Name	I/O	Description
1, 20, 45, 60	VSS	—	GND.
2	LMUTE	O	Lch-“0” detect flag. (Not used)
3	RMUTE	O	Rch-“0” detect flag. (Not used)
4	SQCK	I	Clock input for SQSO read out.
5	SQSO	O	SubQ 80 bit serial output.
6	SENSE	O	SENS signal output to CPU.
7	DATA	I	Serial data input from CPU.
8	XLAT	I	Latch input from CPU. Latch serial data at fall down.
9	CLOK	I	Clock input to serial data transfer from CPU.
10	SEIN	I	SENS input from SSP.
11	CNIN	I	Numbers of track jump are counted and input.
12	DATO	O	Serial data output to SSP.
13	XLTO	O	Serial-data latch output to SSP. Latch at fall down.
14	CLKO	O	Clock output for serial data transfer to SSP.
15	SPOA (SENSE2)	I	Microcomputer expansion interface. (Input A)
16	SPOB (IN/SW)	I	Microcomputer expansion interface. (Input B)
17	XLON	O	Microcomputer expansion interface. (Output)
18	FCOK	I	Focus OK input terminal. Used for SENSE output and servo-auto sequencer.
19, 46, 61, 80	VDD	—	Power supply. (+5V)
21	MDP	O	Servo control for spindle motor.
22	PWM1	I	External control input for spindle motor. (Not used)
23	TEST	I	TEST terminal. (Connected to GND)
24	TEST1	I	TEST terminal. (Connected to GND)
25	VPCO	O	Charge pump output for extensive EFM PLL. (Connected to GND)
26	VCK1	I	VCO2 oscillator input for extensive EFM PLL.
27	V16M	O	VCO2 oscillator output for extensive EFM PLL.
28	VCTL	I	VCO2 control voltage input for extensive EFM PLL. (Connected to GND)
29	PCO	O	Charge pump output for master PLL.
30	FIL0	O	Filter (slave = digital PLL) output for master PLL.
31	FIL1	I	Filter input for master PLL.
32	AVS0	—	Analog GND.
33	CLTV	I	VCO control voltage input for master.
34	AVD0	—	Analog power. (+5V)
35	RF	I	EFM signal input.
36	BIAS	I	Constant current input to asymmetry circuit.
37	ASYI	I	Comparison voltage input to asymmetry circuit.
38	ASYO	O	EFM full-swing output. (L=VSS, H=VDD)
39	LRCK	O	D/A interface, LR clock output f=FS.
40	LRCK1	I	LR clock input.
41	PCMD	O	D/A interface, serial data output. (2's COMP, MSB first)
42	PCMDI	I	D/A interface, serial data input. (2's COMP, MSB first)
43	BCK	O	D/A interface bit clock output.

Pin No.	Pin Name	I/O	Description
44	BCK1	I	D/A interface bit clock input.
47	XUGF	O	XUGF output, MNT1 or RPCK output by switching command. (Not used)
48	XPCK	O	XPLCK output, MNT0 output by switching command. (Not used)
49	GFS	O	GFS output, MNT3 or XRAOF output by switching command. (Not used)
50	C2PO	O	C2PO output, GTOP output by switching command. (Not used)
51	XTSL	I	Crystal select input terminal, Crystal: 16.9344MHz = "L", 33.8688MHz = "H". (Connected to VDD)
52	C4M	O	4.2336MHz output. Output 1/4 divided frequency of VCKI at CAV-W mode. (Not used)
53	DOUT	O	Digital out connector output signal.
54	EMPH	O	"H" when the playback disc has emphasis. "L" when it does not.
55	EMPHI	I	De-emphasis ON/OFF, "H" when ON, "L" when OFF.
56	WFCK	O	WFCK output. (Not used)
57	SCOR	O	H output when the subcode sync S0 or S1 is detected. (Not used)
58	SBSO	O	Serial output for SubP-W. (Not used)
59	EXCK	I	SBSO read out clock input. (Connected to GND)
62	YSM	I	Mute input terminal. Active the "H" setting. (Connected to GND)
63	AVS11	—	Analogue GND.
64	AVD1	—	Analogue power supply. (+5V)
65	AOUT1	O	Lch/analogue output terminal.
66	AIN1	I	Lch/OP AMP input terminal.
67	LOUT1 (L-CH)	O	Lch/LINE output terminal.
68	AVS12	—	Analogue GND.
69	XVDD	—	Power supply for master clock.
70	XTAI	I	Input terminal for crystal oscillator circuit. Input external master clock from this terminal.
71	XTAO	O	Output terminal for crystal oscillator circuit.
72	XVSS	—	GND terminal for master clock.
73	AVSS2	—	Analogue GND.
74	LOUT2 (R-CH)	O	Rch/LINE output terminal.
75	AIN2	I	Rch/OP AMP input terminal.
76	AOUT2	O	Rch/analogue output terminal.
77	AVD2	—	Analogue power supply. (+5V)
78	AVS21	—	Analogue GND.
79	XRST	I	Reset system at "L" setting.

Note:

- PCMD is the two's complement output with MSB first.
- GTOP monitors the protection status of the Frame Sync. (H: Sync protection window opened).
- XUGF is the Frame Sync negative pulse which is obtained from the EFM signal. This is the signal before the sync protection.
- XPLCK is the inverted signal of the EFM PLL clock. The PLL works so that the fall-down edge and the changed point of the EFM signal agree.
- GFS is the signal that goes "H" when the Frame Sync and the internally inserted timing agree.
- RFCK is the signal having 136 micro-seconds (during normal speed) that is generated to have the same accuracy as X'tal.
- C2PO is the signal indicating the error status of the data.
- XRAOF is the signal that is generated when the 16k RAM goes outside the jitter margin $\pm 4F$.

ELECTRICAL MEASUREMENT

PWB,CD

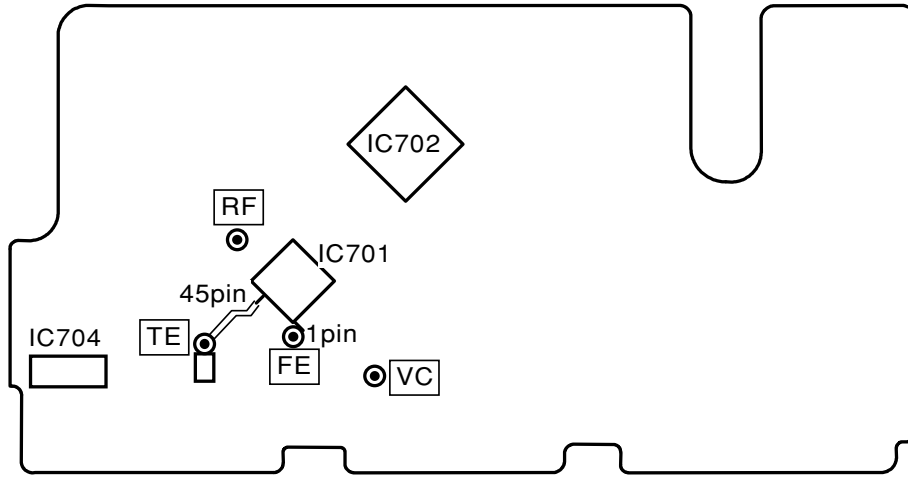

Method of Measuring CD

- Check that it is in the test mode.
- Place the CD mechanism on level ground.

Measuring Device: Oscilloscope (use 10:1 probe) Digital Multimeter (use DCV lens)
 Jitter Meter (KIKUSUI 6235) Test Disc: TCD-782, ATD-001

1. RF Waveform Check

- 1) Connect the test point (RF), (VREF) to the oscilloscope.
- 2) Play back the second track of TCD-782.
- 3) Check that the amplitude of RF waveform is $1.3V \pm 0.3V_{p-p}$ and the rhombus shape at the centre is sharp.

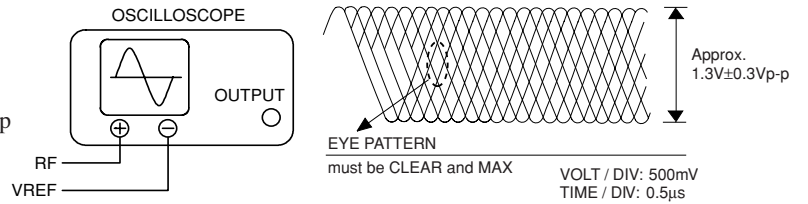

2. Jitter Value Check

- 1) With the oscilloscope connected in step 1, connect the output terminal to the input terminal of the jitter meter.
- 2) Align the voltage knob of the oscilloscope below 500mV.
- 3) Playback the second track of TCD-782.
- 4) Check that the display of jitter meter is below 28.0ns.

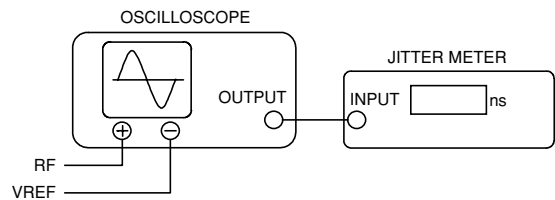

3. Tracking Balance Check

- 1) Connect the test point (TE), (VREF) to the oscilloscope.
- 2) Playback the second track of TCD-782 and press the PAUSE button.
- 3) Check that the traverse waveforms of the oscilloscope are up and down symmetrical.

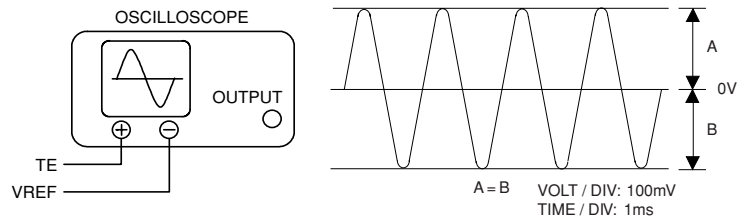

4. Play Ability Check

- 1) Playback track 3, 8, 13 of ATD-001 and check that there is no noise and audio skip.

5. Laser Current Check

- * Do not perform this measurement unless there is laser failure or when it is not as expected.
- 1) Connect both ends of R740(10Ω) to the multimeter.
 - 2) Play back TCD-782 and check the DC voltage value of the multimeter.
 - 3) Check that the laser current $I_{op} < DC$ voltage value of both end $\div 10\Omega(R740) >$ is below 60mA.

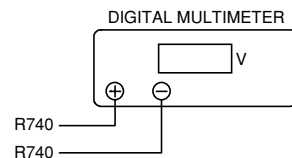

CD TEST MODE

1. How to Activate CD Test Mode

While pressing the CD PLAY button, insert the AC plug.
When the test mode starts, all lights on the display are lit.

2. How to Cancel CD Test Mode

Press the POWER button or remove the AC plug.
* The test mode is cancelled by other function keys during play.

3. Function and Usage of CD Test Mode

No	Mode	Button for Activation	Display	Operation	Contents
1	Start Mode		All lights are lit.		<ul style="list-style-type: none"> • Microcomputer check
2	Search Mode	STOP button	READING	<ul style="list-style-type: none"> • Laser diode is lit during the mode. • Focus search continuous operation. *1 	<ul style="list-style-type: none"> • APC circuit check • Laser current measurement • Focus search waveform check • Focus error waveform check
3	Play Mode	PLAY button	Normal	<ul style="list-style-type: none"> • Normal playback. • Focus search continues if TOC READ cannot be read. 	<ul style="list-style-type: none"> • All servo circuits check
4	Traverse Mode	PAUSE button	Normal	<ul style="list-style-type: none"> • Tracking Servo OFF/ON. STOP button to cancel. 	<ul style="list-style-type: none"> • Tracking balance check
5	Sled Mode	F.SKIP button	CD TEST	<ul style="list-style-type: none"> • PU moves to inner track. *2 	<ul style="list-style-type: none"> • Sled circuit check • Tracking circuit check • Mechanism operation check • PU check
		B.SKIP button	CD TEST	<ul style="list-style-type: none"> • PU is moves to outer track. *2 At the same time, the lens is kicked to outer track. 	

* 1 ... When focus search operates continuously for more than 10 minutes, the protection circuit may start due to generation of heat in the driver IC. If this happens, turn off the power, leave the unit for a while and then, restart.

* 2 ... Carefully monitor the gear against damage, as the sled motor rotates while the "FF" or "RWD" button is pressed even when the pickup is located at innermost or outermost.

* 3 ... The pickup is in the outer track position which prevents OPEN/CLOSE of the CD tray.

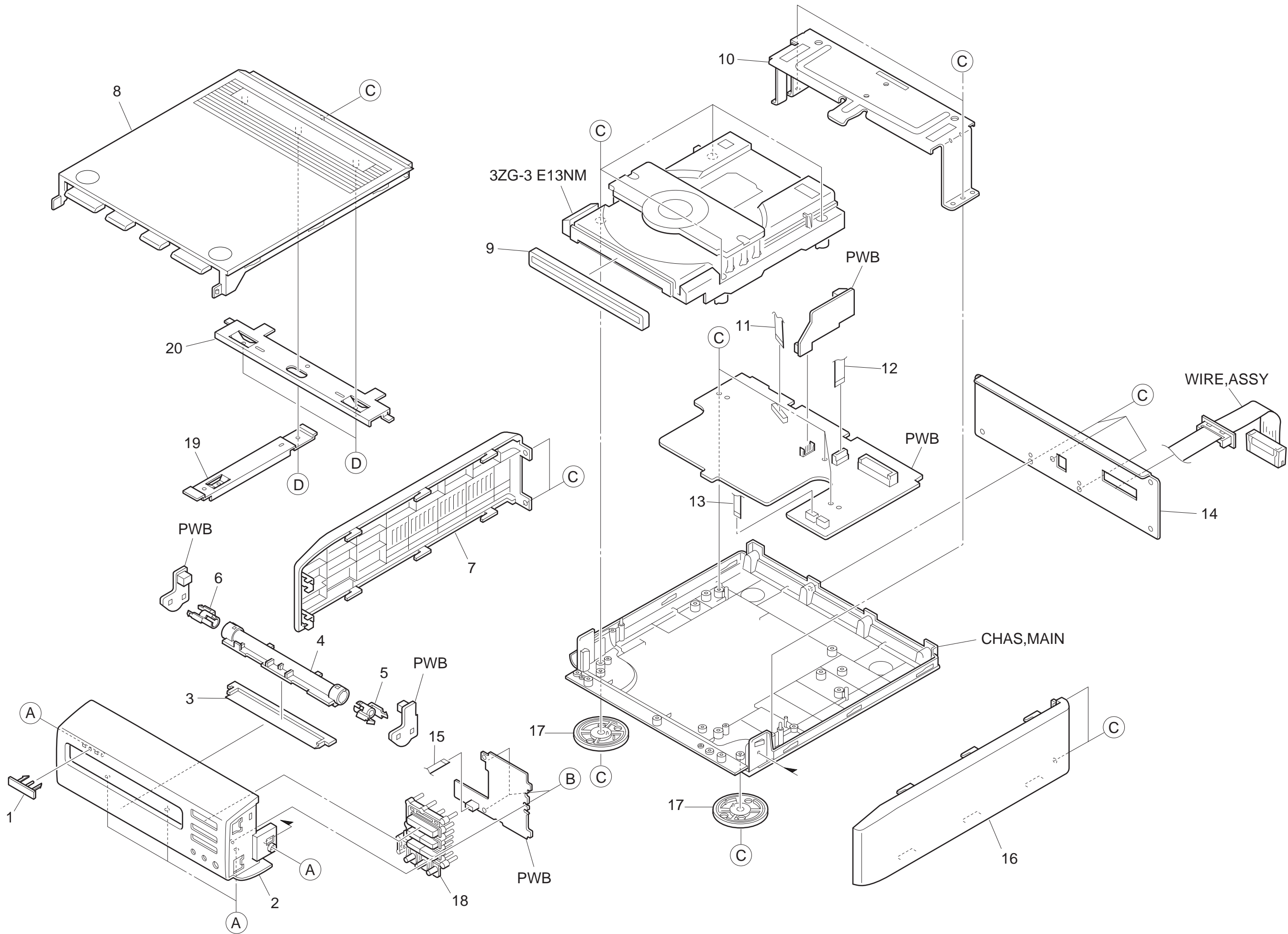

MECHANICAL PARTS LIST 1 / 1

REF. NO.	PART NO.	KANRI NO.	DESCRIPTION
1	8Z-CC3-007-010		BADGE,AIWA 27.5 ABS SIL
2	8B-CX1-001-010		CABI,FR CD
3	8B-CE1-018-010		REFLECTOR,FR
4	8B-CE1-208-010		GUIDE,LED CNT
5	8Z-CE3-204-010		GUIDE,LED R
6	8Z-CE3-203-010		GUIDE,LED L
7	8B-CF1-005-010		PANEL,SIDE L
8	8B-CF1-011-010		PANEL, TOP
9	8B-CX1-007-010		PANEL ASSY,TRAY CD
10	8B-CF1-205-010		PLATE, TOP
11	8B-CX1-621-010		FF-CABLE,16P 1.0 200MM
12	88-906-151-110		FF-CABLE,6P 1.25
13	88-905-301-110		FF-CABLE, 5P 300MM
14	8B-CX1-006-010		PANEL,REAR CD
15	88-904-201-110		FF-CABLE, 4P 1.25
16	8B-CF1-006-010		PANEL,SIDE R
17	8B-CE1-016-010		FOOT,DIA40 H4
18	8B-CX1-004-010		KEY,PLAY CD
19	8B-CE1-212-010		PLATE, TOP A
20	8B-CE1-213-010		PLATE, TOP B
A	87-721-096-410		QT2+3-10 GLD
B	87-B10-294-010		BVT2+2.6-8
C	87-067-703-010		TAPPING SCREW, BVT2+3-10
D	87-067-684-010		BVT2+2.6-6 W/O SLOT

COLOR NAME TABLE

Basic color symbol	Color	Basic color symbol	Color	Basic color symbol	Color
B	Black	C	Cream	D	Orange
G	Green	H	Gray	L	Blue
LT	Transparent Blue	N	Gold	P	Pink
R	Red	S	Silver	ST	Titan Silver
T	Brown	V	Violet	W	White
WT	Transparent White	Y	Yellow	YT	Transparent Yellow
LM	Metallic Blue	LL	Light Blue	GT	Transparent Green
LD	Dark Blue	DT	Transparent Orange	GM	Metallic Green
YM	Metallic Yellow	DM	Metallic Orange	PT	Transparent Pink
LA	Aqua Blue	GL	Light Green	HT	Transparent Gray

CD MECHANISM EXPLODED VIEW 1 / 2 < 3ZG-3 E13NM >

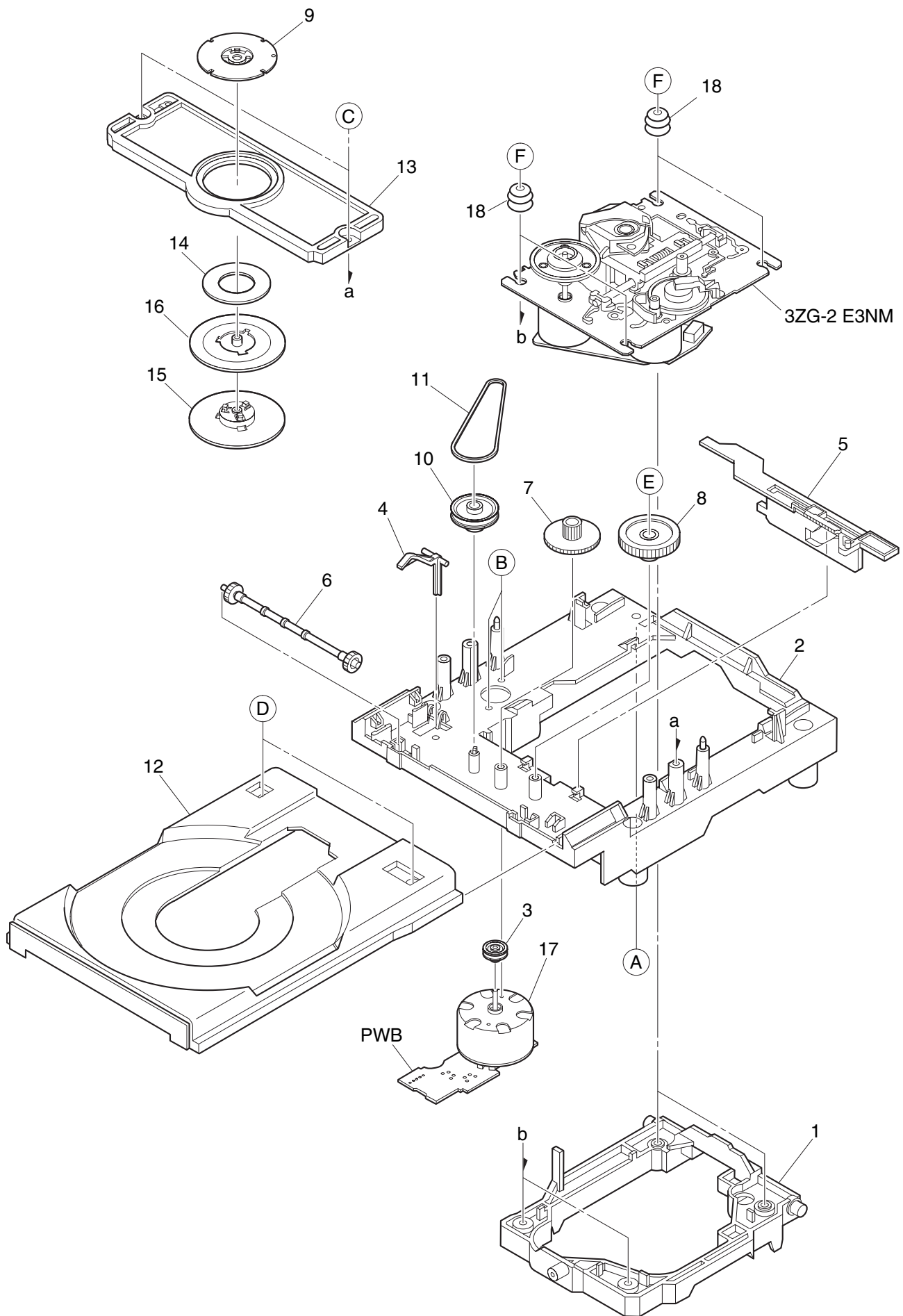

CD MECHANISM PARTS LIST 1 / 2 < 3ZG-3 E13NM >

REF. NO.	PART NO.	KANRI NO.	DESCRIPTION
1	83-ZG3-224-510		HLLDR M2
2	83-ZG3-228-610		CHAS, L6
3	83-ZG3-208-010		PULLEY, MOTOR
4	83-ZG3-213-010		LVR, SW
5	83-ZG3-209-610		CAM, SLIDE
6	83-ZG3-207-010		GEAR, TRAY
7	83-ZG3-204-210		GEAR, C
8	83-ZG3-205-010		GEAR, D
9	83-ZG3-219-010		PLATE, CLAMP
10	83-ZG3-220-210		GEAR, PULLEY 2
11	83-ZG3-214-010		BELT, L
12	83-ZG3-231-210		TRAY, CD 3
13	83-ZG3-230-110		HLLDR, CHUCK 2 (*)
14	86-ZG1-239-110		PLATE, DISC PC
15	83-ZG3-604-010		RING, MAG 2
16	86-ZG1-238-010		HLLDR, MAGNET 6ZG N
17	87-045-305-010		MOTOR, RF-500TB DC-5V (2MA)
18	83-ZG3-225-010		CUSH-G, MAIN A
A	87-067-945-110		VFT2+3-12 (F10)
B	87-251-071-410		U+2.6-4
C	83-ZG3-235-010		VFT2+2.6-8
D	87-352-075-210		VT2+2.6-10
E	83-ZG3-217-010		S-SCREW, GEAR D
F	81-ZG1-254-010		S-SCREW, MECH HLLDR

CD MECHANISM EXPLODED VIEW 2 / 2 < 3ZG-2 E3NM >

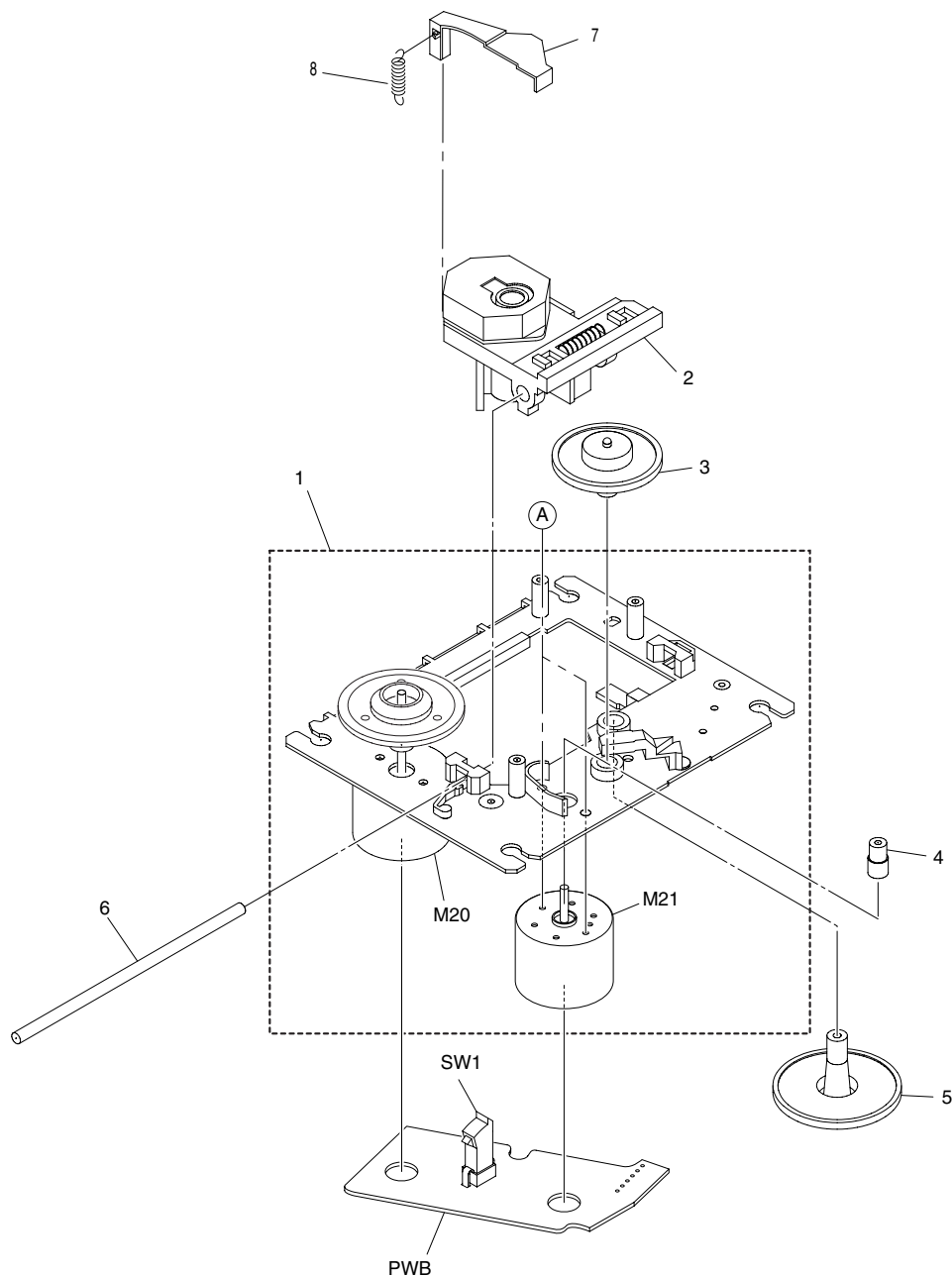

CD MECHANISM PARTS LIST 2 / 2 < 3ZG-2 E3NM >

REF. NO.	PART NO.	KANRI NO.	DESCRIPTION
1	83-ZG2-262-010		CHAS ASSY, E3
2	87-A90-836-010		PICKUP, KSS-213F
3	83-ZG2-235-010		GEAR, A3
4	83-ZG2-236-010		GEAR, MOTOR 3
5	83-ZG2-205-310		GEAR, B
6	83-ZG2-253-010		SHAFT, SLIDE 5
7	83-ZG2-245-510		LEVER, SHUTTER (*)
8	83-ZG2-250-210		SPR-E, SHT 2
A	87-261-032-210		V+2-3

GENERAL SPEAKER DISASSEMBLY INSTRUCTIONS (FOR REFERENCE)

Type.1

Insert a flat-bladed screwdriver into the position indicated by the arrows and remove the panel. Remove the screws of each speaker unit and then remove the speaker units.

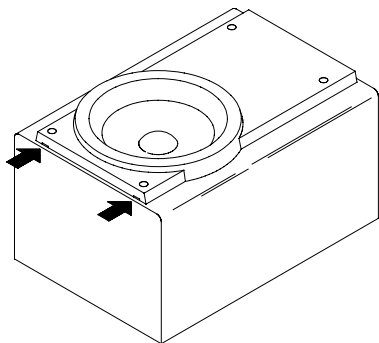

Type.2

Remove the grill frame and four pieces of rubber caps by pulling out with a flat-bladed screwdriver. Remove the screws from hole where installed rubber caps. Insert a flat-bladed screwdriver into the position indicated by the arrows and remove the panel. Remove the screws of each speaker unit and then remove the speaker units.

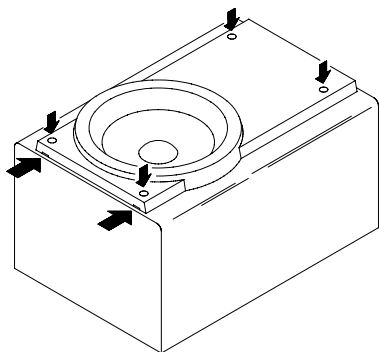

Type.3

Insert a flat-bladed screwdriver into the position indicated by the arrows and remove the panel. Turn the speaker unit to counter-clockwise direction while inserting a flat-bladed screwdriver into one of the hollows around speaker unit, and then remove the speaker unit. After replacing the speaker unit, install it turning to clockwise direction until "click" sound comes out.

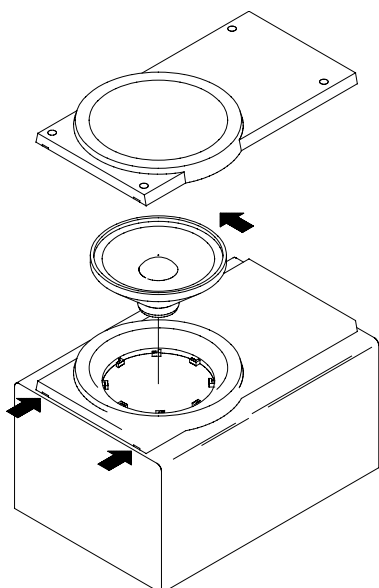

Type.4

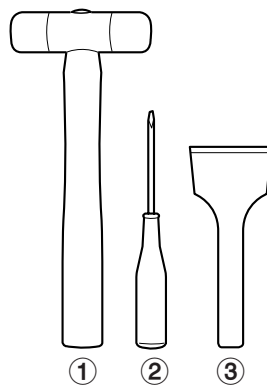

TOOLS

- ① Plastic head hammer
- ② (⊖) flat head screwdriver
- ③ Cut chisel

How to Remove the PANEL, FR

1. Insert the (⊖) flat head screwdriver tip into the gap between the PANEL, FR and the PANEL, SPKR. Tap the head of the (⊖) flat head screwdriver with the plastic hammer head, and create the clearance as shown in Fig-1.
2. Insert the cut chisel in the clearance, and tap the head of the cut chisel with plastic hammer as shown in Fig-2, to remove the PANEL, FR.
3. Place the speaker horizontally. Tap head of the cut chisel with plastic hammer as shown in Fig-3, and remove the PANEL, FR completely.

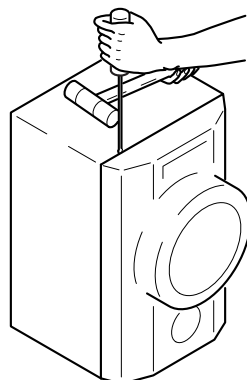

Fig-1

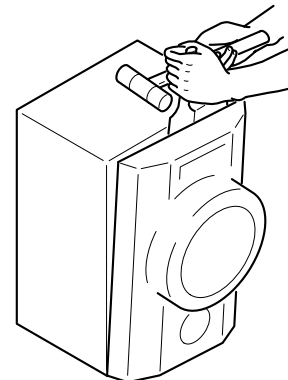

Fig-2

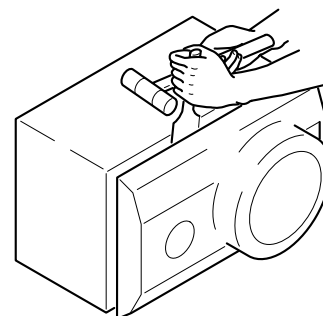

Fig-3

How to Attach the PANEL, FR

Attach the PANEL, FR to the PANEL, SPKR. Tap the four corners of the PANEL, FR with the plastic hammer to fit the PANEL, FR into the PANEL, SPKR completely.

SPEAKER PARTS LIST <SX-LM918 (YML, YJMN)>

REF. NO.	PART NO.	KANRI NO.	DESCRIPTION
1	8B-CP1-002-010		RING, W
2	8B-CP1-003-010		RING, TW A
3	8B-CP1-004-010		RING, TW B
4	8B-CP1-005-010		GRILLE, FRAME ASSY
5	8B-CP1-602-010		SPKR, W 140 25/2G
6	8B-CP1-604-010		SPKR, TW 25/2
7	8A-CJ5-415-010		TERMINAL
8	8B-CP5-610-010		CORD, SPKR

ACCESSORIES / PACKAGE LIST

REF. NO.	PART NO.	KANRI NO.	DESCRIPTION
1	8B-CE1-905-010		IB, K (E) M<K>
1	8B-CE1-906-010		IB, EZ (5L) M<EZ>
1	8B-CE1-907-010		IB, EZ (4L) M<EZ>
2	87-A90-118-010		ANT, WIRE FM (Z)
3	87-006-226-010		ANT, LOOP AM
4	8B-CE1-951-010		RC UNIT, RC-BAT02
△ 5	87-099-811-010		PLUG, ADPTR CONV (K) <K>

アイワ株式会社 〒110-8710 東京都台東区池之端1-2-11 ☎03(3827)3111 (代表)
AIWA CO.,LTD. 2-11, IKENOHATA 1-CHOME, TAITO-KU, TOKYO 110, JAPAN TEL:03 (3827) 3111