

SERVICE MANUAL

MD/CD STEREO SYSTEM

- BASIC MD MECHANISM : 7ZG-9B
- BASIC CD MECHANISM : KSM-620AAA

SYSTEM	RECEIVER	MD/CD	SPEAKER
XR-MD201	RX-LMD201	FD-LMD201	SX-LM200
XR-MD200	RX-LMD200	FD-LMD200	SX-LM200

This Service Manual is the "Revision Publishing" and replaces "Simple Manual" (S/M Code No.09-995-329-3T1).

TABLE OF CONTENTS

SPECIFICATIONS	3, 4
ACCESSORIES/PACKAGE LIST	3
PROTECTION OF EYES FROM LASER BEAM DURING SERVICING/ Precaution to replace Optical block	5
DISASSEMBLY INSTRUCTIONS	6-9
MODEL NO. RX-LMD200/LMD201	
ELECTRICAL MAIN PARTS LIST	10-12
TRANSISTOR ILLUSTRATION	12
BLOCK DIAGRAM	13, 14
WIRING-1 (POWER AMP)	15, 16
SCHEMATIC DIAGRAM-1 (POWER AMP)	17, 18
WIRING-2 (FRONT)	19, 20
SCHEMATIC DIAGRAM-2 (FRONT)	21, 22
WIRING-3 (TUNER)	23, 24
SCHEMATIC DIAGRAM-3 (TUNER)	25, 26
ELECTRICAL ADJUSTMENT	27, 28
PRACTICAL SERVICE FIGURE	28
IC DESCRIPTION	29, 30
IC BLOCK DIAGRAM	31
FL GRID ASSIGNMENT/ANODE CONNECTION	32
MECHANICAL EXPLODED VIEW 1/1	33
MECHANICAL PARTS LIST 1/1	34
MODEL NO. FM-LMD200/LMD201	
ELECTRICAL MAIN PARTS LIST	35-38
TRANSISTOR ILLUSTRATION	38
BLOCK DIAGRAM-1 (CD)	39, 40
BLOCK DIAGRAM-2 (MD)	41, 42
WIRING-1 (CD)	43-46
SCHEMATIC DIAGRAM-1 (CD 1/2)	47, 48
SCHEMATIC DIAGRAM-2 (CD 2/2)	49, 50
WIRING-2 (FUNCTION)	51, 52
SCHEMATIC DIAGRAM-3 (FUNCTION)	53, 54
WIRING-3 (MD)	55, 56
SCHEMATIC DIAGRAM-4 (MD)	57, 58
WIRING-4 (MECHANISM)	59
TEST MODE	60-64
ELECTRICAL ADJUSTMENT	65
IC DESCRIPTION	66-79
IC BLOCK DIAGRAM	80-83
MECHANICAL EXPLODED VIEW 1/1	84
MECHANICAL PARTS LIST 1/1	85
CD MECHANISM EXPLODED VIEW 1/1	86
CD MECHANISM PARTS LIST 1/1	86
MD MECHANISM EXPLODED VIEW 1/3	87
MD MECHANISM PARTS LIST 1/3	87
MD MECHANISM EXPLODED VIEW 2/3	88
MD MECHANISM PARTS LIST 2/3	89
MD MECHANISM EXPLODED VIEW 3/3	90
MD MECHANISM PARTS LIST 3/3	91
MODEL NO. SX-LMD200	
SPEAKER DISASSEMBLY INSTRUCTIONS	92
SPEAKER PARTS LIST 1/1	93

SPECIFICATIONS

K MODEL

STEREO RECEIVER RX-LMD200

FM tuner section

Tuning range	87.5 MHz to 108 MHz
Usable sensitivity (IHF)	13.2 dBf
Antenna terminals	75 ohms (unbalanced)

MW tuner section

Tuning range	531 kHz to 1602 kHz (9 kHz step) 530 kHz to 1710 kHz (10 kHz step)
Usable sensitivity	350 µV/m
Antenna	Loop antenna

LW tuner section

Tuning range	144 kHz to 290 kHz
Usable sensitivity	1400 µV/m
Antenna	Loop antenna

Amplifier section

Power output	Rated: 16 W + 16 W (6 ohms, T.H.D. 1%, 1kHz/DIN 45500) Reference: 20 W + 20 W (6 ohms, T.H.D. 10%, 1kHz/DIN 45324) DIN MUSIC POWER 30 W + 30 W
Outputs	SUPER WOOFER: 1.2 V SPEAKERS: accept speakers of 6 ohms or more PHONES (stereo minijack): accepts headphones of 32 ohms or more

General

Power requirements	230 V AC, 50 Hz
Power consumption	56 W
Standby power consumption	2.5 W (power economizing mode set to ON)
Dimensions (W × H × D)	144 × 100 × 206.5 mm
Weight	2.7 kg

STEREO MD RECORDER/COMPACTDISC PLAYER FM-LMD200

Compact disc player section

Laser	Semiconductor laser (λ = 780 nm)
D-A converter	1 bit dual
Signal-to-noise ratio	85 dB (1 kHz, 0 dB)
Harmonic distortion	0.05 % (1 kHz, 0 dB)
Wow and flutter	Unmeasurable

MD recorder section

Scanning method	Non-contact optical scanner (Semiconductor laser application)
Recording system	Magnetic polarity modulation overwrite system
Rotation speed	Approx. 400 - 900 rpm (CLV)
Sampling frequency	44.1 kHz
No. of channels	Stereo: 2 channels Monaural: 1 channel
A-D, D-A converter	1-bit
Frequency	20 - 20000 Hz +0.2 - -1.5 dB
Wow and flutter	Unmeasurable

General

Inputs	TAPE IN: 470 mV AUX IN: 400 mV DIGITAL IN
Output	LINE OUT: 400 mV
Dimensions (W × H × D)	144 × 100.6 × 203 mm
Weight	1.5 kg

SPEAKER SYSTEM SX-LM200

Cabinet type	2 way, bass reflex (magnetic shielded type)
Speakers	Woofer: 100 mm cone type Tweeter: 25 mm balanced dome type
Impedance	6 ohms
Output sound pressure level	87 dB/W/m
Dimensions (W × H × D)	120 × 200 × 182 mm
Weight	1.6 kg

- Design and specifications are subject to change without notice.
- Dolby noise reduction manufactured under license from Dolby Laboratories Licensing Corporation. "DOLBY" and the double-D symbol  are trademarks of Dolby Laboratories Licensing Corporation.
- The word "BBE" and the "BBE symbol" are trademarks of BBE Sound, Inc. Under license from BBE Sound, Inc.

ACCESSORIES/PACKAGE LIST

DESCRIPTIONで判断できない物は "REFERENCE NAME LIST" を参照してください。
If can't understand for Description please kindly refer to "REFERENCE NAME LIST".

REF. NO	PART NO.	KANRI NO.	DESCRIPTION
1	8Z-CL1-905-010		IB, K(E)I<200KS>
1	8Z-CL1-906-010		IB, EZ(9L)I<201EVS>
2	8Z-CL1-950-010		RC UNIT, ZCL-1
3	87-A90-118-010		ANT, WIRE FM (Z)
4	87-A90-030-010		ANT, LOOP AM-NC C

EZ MODEL

STEREO RECEIVER RX-LMD201

FM tuner section

Tuning range	87.5 MHz to 108 MHz
Usable sensitivity (IHF)	13.2 dBf
Antenna terminals	75 ohms (unbalanced)

MW tuner section

Tuning range	531 kHz to 1602 kHz (9 kHz step) 530 kHz to 1710 kHz (10 kHz step)
Usable sensitivity	350 μ V/m
Antenna	Loop antenna

LW tuner section

Tuning range	144 kHz to 290 kHz
Usable sensitivity	1400 μ V/m
Antenna	Loop antenna

Amplifier section

Power output	Rated: 16 W + 16 W (6 ohms, T.H.D. 1%, 1kHz/DIN 45500) Reference: 20 W + 20 W (6 ohms, T.H.D. 10%, 1kHz/DIN 45324) DIN MUSIC POWER 30 W + 30 W
Outputs	SUPER WOOFER: 1.2 V SPEAKERS: accept speakers of 6 ohms or more PHONES (stereo minijack): accepts headphones of 32 ohms or more

General

Power requirements	230 V AC, 50 Hz
Power consumption	56 W
Standby power consumption	2.5 W (power economizing mode set to ON)
Dimensions (W \times H \times D)	144 \times 100 \times 206.5 mm
Weight	2.7 kg

STEREO MD RECORDER/COMPACT DISC PLAYER FM-LMD201

Compact disc player section

Laser	Semiconductor laser ($\lambda = 780$ nm)
D-A converter	1 bit dual
Signal-to-noise ratio	85 dB (1 kHz, 0 dB)
Harmonic distortion	0.05 % (1 kHz, 0 dB)
Wow and flutter	Unmeasurable

MD recorder section

Scanning method	Non-contact optical scanner (Semiconductor laser application)
Recording system	Magnetic polarity modulation overwrite system
Rotation speed	Approx. 400 – 900 rpm (CLV)
Sampling frequency	44.1 kHz
No. of channels	Stereo: 2 channels Monaural: 1 channel
A-D, D-A converter	1-bit
Frequency	20 – 20000 Hz $^{+0.2}_{-1.5}$ dB
Wow and flutter	Unmeasurable

General

Inputs	TAPE IN: 470 mV AUX IN: 400 mV DIGITAL IN LINE OUT: 400 mV 144 \times 100.6 \times 203 mm
Output	
Dimensions (W \times H \times D)	
Weight	1.5 kg

SPEAKER SYSTEM SX-SML200

Cabinet type	2 way, bass reflex (magnetic shielded type)
Speakers	Woofer: 100 mm cone type Tweeter: 25 mm balanced dome type
Impedance	6 ohms
Output sound pressure level	87 dB/W/m
Dimensions (W \times H \times D)	120 \times 200 \times 182 mm
Weight	1.6 kg

- Design and specifications are subject to change without notice.
- Dolby noise reduction manufactured under license from Dolby Laboratories Licensing Corporation. "DOLBY" and the double-D symbol $\square\square$ are trademarks of Dolby Laboratories Licensing Corporation.
- The word "BBE" and the "BBE symbol" are trademarks of BBE Sound, Inc. Under license from BBE Sound, Inc.

PROTECTION OF EYES FROM LASER BEAM DURING SERVICING

This set employs laser. Therefore, be sure to follow carefully the instructions below when servicing.

WARNING!

WHEN SERVICING, DO NOT APPROACH THE LASER EXIT WITH THE EYE TOO CLOSELY. IN CASE IT IS NECESSARY TO CONFIRM LASER BEAM EMISSION. BE SURE TO OBSERVE FROM A DISTANCE OF MORE THAN 30cm FROM THE SURFACE OF THE OBJECTIVE LENS ON THE OPTICAL PICK-UP BLOCK.

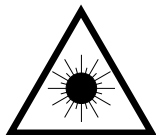

- Caution: Invisible laser radiation when open and interlocks defeated avoid exposure to beam.
- Advarsel: Usynlig laserstråling ved åbning, når sikkerhedsafbrydere er ude af funktion. Undgå udsættelse for stråling.

VAROITUS!

Laitteen Käyttäminen muulla kuin tässä käyttöohjeessa mainitulla tavalla saattaa altistaa käyttäjän turvallisuusluokan 1 ylittävälle näkymättömälle lasersäteilylle.

WARNING!

Om apparaten används på annat sätt än vad som specificeras i denna bruksanvisning, kan användaren utsättas för osynlig laserstrålning, som överskrider gränsen för laserklass 1.

CAUTION

Use of controls or adjustments or performance of procedures other than those specified herein may result in hazardous radiation exposure.

ATTENTION

L'utilisation de commandes, réglages ou procédures autres que ceux spécifiés peut entraîner une dangereuse exposition aux radiations.

ADVARSEL!

Usynlig laserstråling ved åbning, når sikkerhedsafbrydere er ude af funktion. Undgå udsættelse for stråling.

This Compact Disc player is classified as a CLASS 1 LASER product.

The CLASS 1 LASER PRODUCT label is located on the rear exterior.

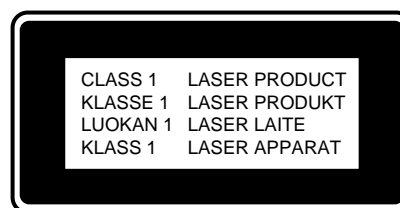

www.xiaoyu163.com

Precaution to replace Optical block (KSM-620AAA)

Body or clothes electrostatic potential could ruin laser diode in the optical block. Be sure ground body and workbench, and use care the clothes do not touch the diode.

- 1) After the connection, remove solder shown in the right figure.

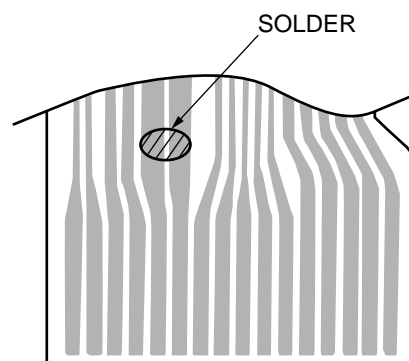

DISASSEMBLY INSTRUCTIONS

1. Remove the two screws.

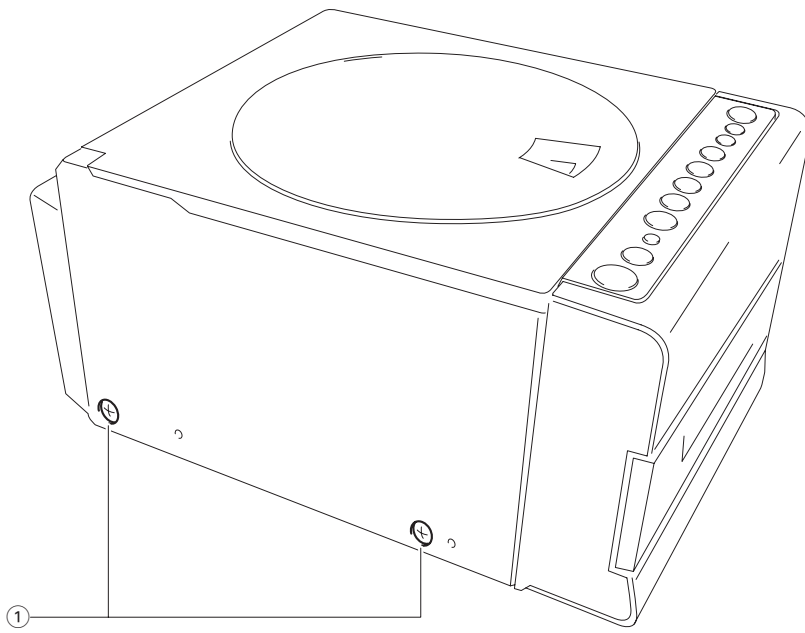

2. Remove the two screws.

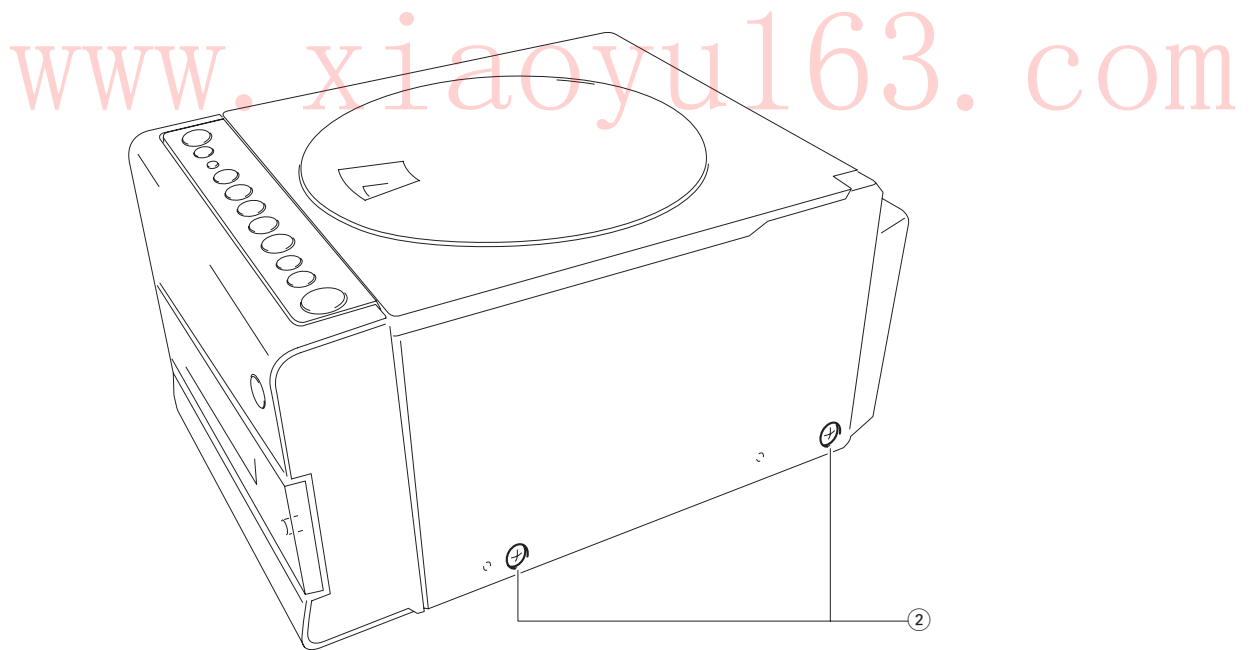

3. Remove the screw.

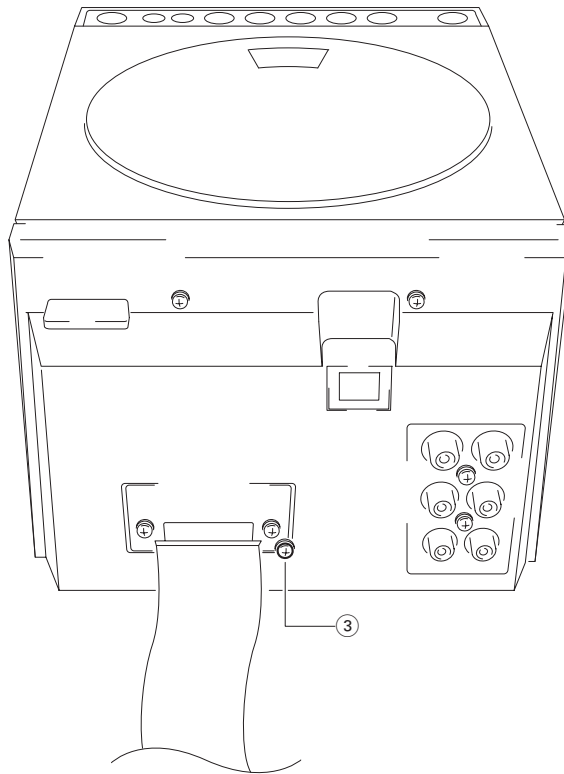

4. While moving up the rear in the direction as shown, remove the PANEL, TOP together with the entire CD MECA.

www.xiaoyu163.com

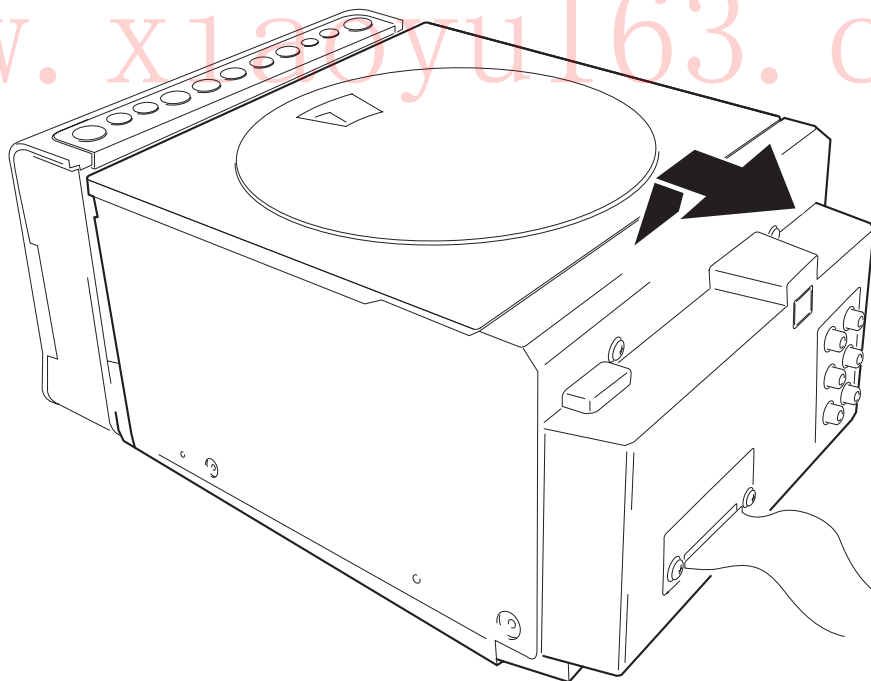

5. Remove the seven screws and remove the PANEL, REAR FD.

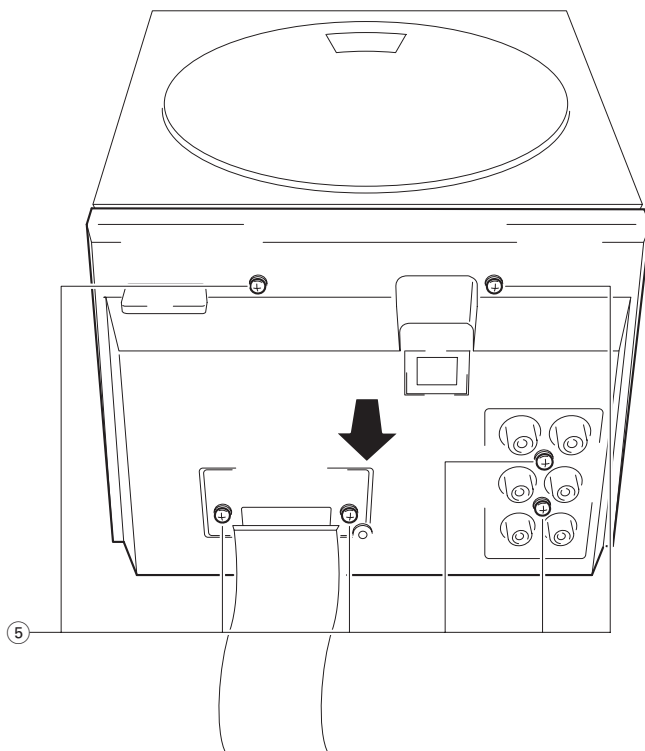

6. The CD MECA can be removed when the two screws are removed.

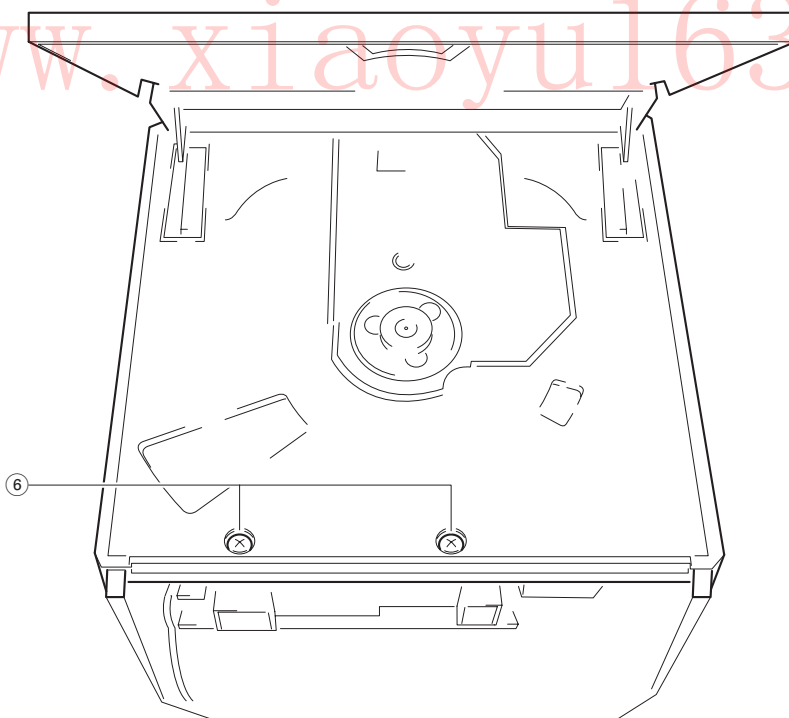

7. Remove the seven screws.

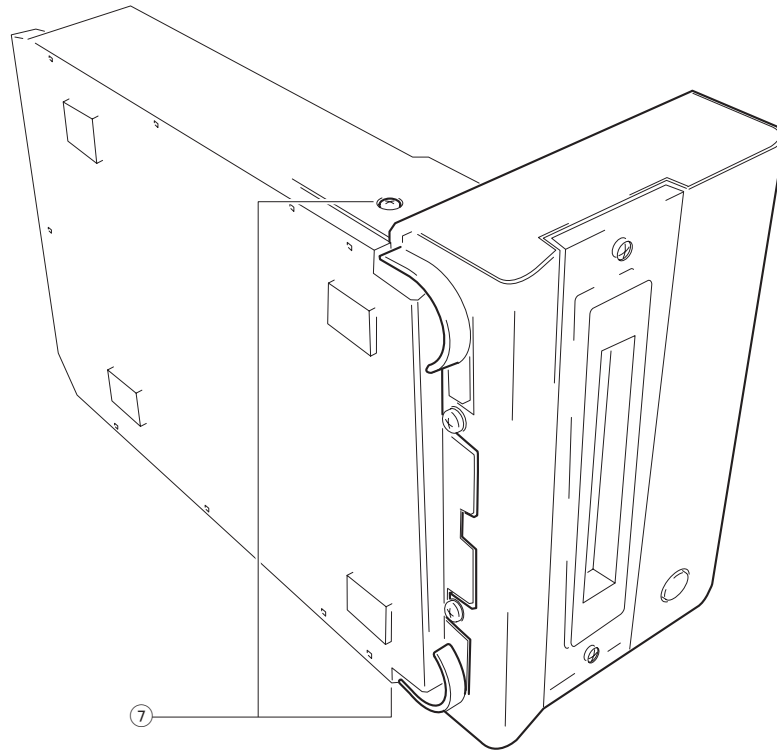

8. The CABI, FR FD can be removed when the claws on both sides are removed and are pulled to the front.

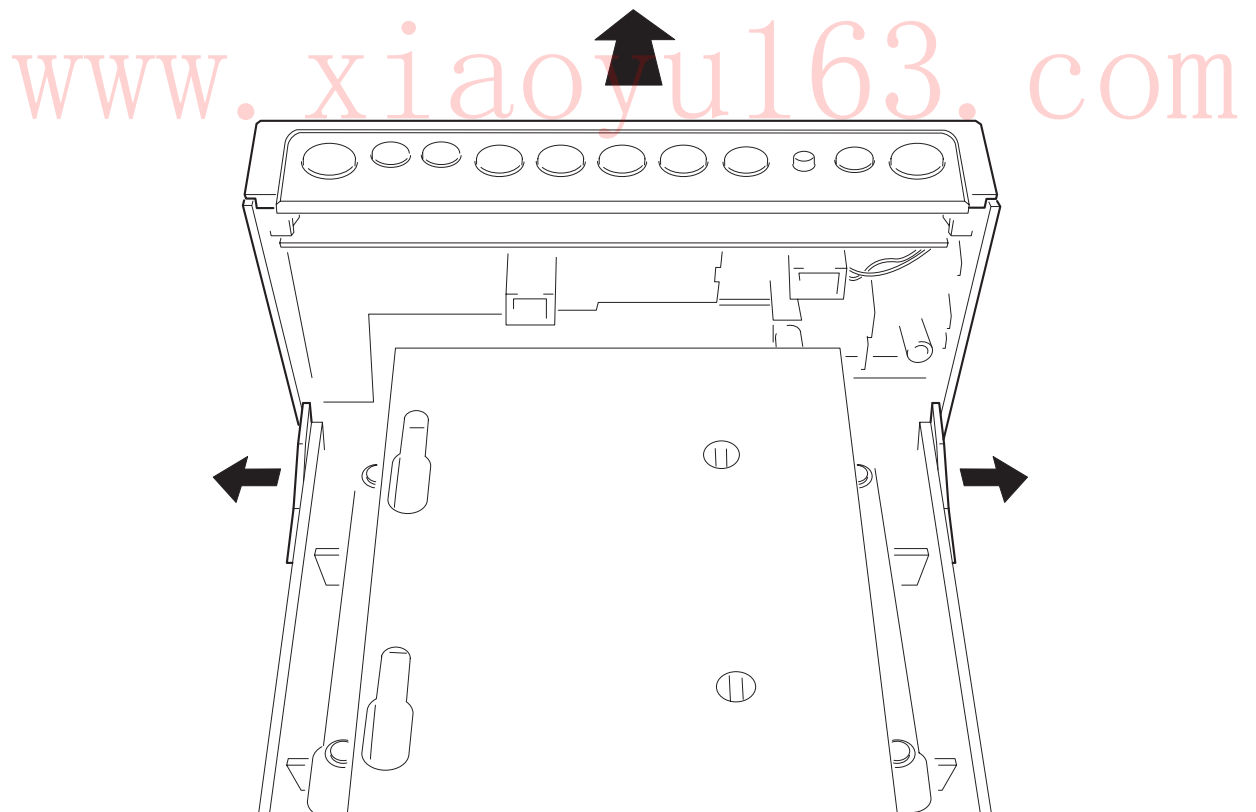

MODEL NO. RX-LMD200/LMD201

ELECTRICAL MAIN PARTS LIST

DESCRIPTIONで判断できない物は "REFERENCE NAME LIST" を参照してください。
If can't understand for Description please kindly refer to "REFERENCE NAME LIST".

REF. NO	PART NO.	KANRI NO.	DESCRIPTION	REF. NO	PART NO.	KANRI NO.	DESCRIPTION
IC				C183	87-010-322-080		C-CAP,S 100P-50 J CH
	87-070-127-110	IC,LC72131 D		C184	87-010-322-080		C-CAP,S 100P-50 J CH
	87-A20-913-010	IC,LA1837NL		C185	87-010-322-080		C-CAP,S 100P-50 J CH
	8Z-CL1-627-010	IC,LC866532A-5L31RX		C186	87-010-322-080		C-CAP,S 100P-50 J CH
	87-A20-440-040	C-IC,BU1920FS<EZ>		C187	87-010-322-080		C-CAP,S 100P-50 J CH
TRANSISTOR				C191	87-A10-479-080		CAP,CER 2200P-250 M E KH
	89-213-702-010	TR,2SB1370 (1.8W)		C195	87-010-405-080		CAP, ELECT 10-50V
	87-026-610-080	TR,KTC3198GR		C281	87-010-401-080		CAP, ELECT 1-50V
	87-A30-076-080	C-TR,2SC3052F		C282	87-010-263-080		CAP, ELECT 100-10V
	87-A30-075-080	C-TR,2SA1235F		C283	87-010-380-080		CAP, ELECT 47-16V
	87-A30-234-080	TR,CSC4115BC		C284	87-010-405-080		CAP, ELECT 10-50V
	87-026-609-080	TR,KTAL266GR		CN101	87-A60-813-010		CONN,8P H BLK TAC-L8X
	87-A30-073-080	C-TR,RT1N 141C		CN102	87-A60-813-010		CONN,8P H BLK TAC-L8X
	87-A30-190-080	TR,CC5551		CN104	87-A60-770-010		CONN,18P B TMC-D(X)
	87-A30-307-010	TR,2SD2619		CN114	87-099-570-010		CONN,13P TUC-P13P-B1<K>
	87-A30-306-010	TR,2SB1677		CN203	87-A60-109-010		CONN,2P V S2M-2W
	87-A30-119-040	C-TR,2SC3906K R		CN301	87-A60-778-010		CONN,18P B TMC-D(P)
	87-A30-047-080	TR,CSD655E		CN302	87-A60-058-010		CONN,10P V 9604S-10C
	87-A30-107-070	C-TR,CMBT5401		CN305	8Z-CL1-665-010		CONN ASSY,5P FR
	87-A30-074-080	C-TR,RT1P 141C		J201	87-A60-420-010		JACK,3.5 ST (MSC)
	87-A30-071-080	C-TR,RT1N 144C		J202	87-099-801-010		JACK,PIN 1P BLK
	87-A30-087-080	C-FET,2SK2158		J501	87-A60-782-010		CONN,19P H FG
	87-A30-072-080	C-TR,RT1P 144C		W101	8Z-CL1-656-010		F-CABLE,7P 2.5 150MM PWR
	89-327-143-080	TR,2SC2714 (0.1W)		W102	8Z-CL1-654-010		F-CABLE,2P 2.5 170MM SUBPT
	89-505-434-540	C-FET,2SK543(4/5)		W103	8Z-CL1-655-010		F-CABLE,4P 2.5 100MM PWR
	87-A30-086-070	C-TR,CSD1306E		WH102	87-A90-460-010		HLDL,WIRE 2.5-7P
FRONT C.B							
DIODE				C301	87-012-145-080		CAP, CHIP S 270P CH
	87-070-345-080	DIODE,IN4148		C303	87-010-312-080		C-CAP,S 15P-50 CH
	87-070-178-090	DIODE,1N5402-BD54		C304	87-015-785-080		CHIP CAPACITOR, 0.1FZ-25Z
	87-070-274-080	DIODE,1N4003 SEM		C305	87-010-196-080		CHIP CAPACITOR,0.1-25
	87-A40-345-080	ZENER,MTZJ10C		C341	87-010-493-080		CAP,E 0.47-50 GAS
	87-A40-269-080	C-DIODE,MC2836		C342	87-A10-189-040		CAP,E 220-10
	87-A40-270-080	C-DIODE,MC2838		C343	87-010-196-080		CHIP CAPACITOR,0.1-25
	87-A40-004-080	ZENER,MTZJ16A		C347	87-010-405-080		CAP, ELECT 10-50V
	87-A40-312-080	ZENER,DZ33M		C351	87-010-194-080		CAP, CHIP 0.047
	87-A40-313-080	C-DIODE,MC 2840		C352	87-010-194-080		CAP, CHIP 0.047
	87-A40-488-080	DIODE,1SS244		C358	87-010-263-080		CAP, ELECT 100-10V
	87-A40-509-080	ZENER,MTZJ6.8C		C371	87-010-404-080		CAP, ELECT 4.7-50V
	87-017-149-080	ZENER,HZS6A2L		C372	87-010-404-080		CAP, ELECT 4.7-50V
	87-020-465-080	DIODE,1SS133 (110MA)		C373	87-010-408-080		CAP, ELECT 47-50V
				FL301	8Z-CL1-630-010		FL,13-ST-36GNAK
MAIN C.B				HL301	8Z-CL1-204-010		HLDL,FL
	C101	87-010-387-080	CAP,E 470-25 SME	L301	87-A50-052-010		COIL,CLOCK 5.76MHZ T1
	C102	87-016-051-090	CAP,E 2200-35 SMG	LED361	87-A40-568-010		LED,L-13HD RED
	C103	87-016-051-090	CAP,E 2200-35 SMG	POWER AMP C.B			
	C106	87-010-196-080	CHIP CAPACITOR,0.1-25	C201	87-010-260-080		CAP, ELECT 47-25V
	C107	87-010-196-080	CHIP CAPACITOR,0.1-25	C202	87-010-260-080		CAP, ELECT 47-25V
	C108	87-010-196-080	CHIP CAPACITOR,0.1-25	C203	87-A10-946-080		C-CAP,S 220P-100 J CH
	C109	87-010-196-080	CHIP CAPACITOR,0.1-25	C204	87-A10-946-080		C-CAP,S 220P-100 J CH
	C110	87-010-928-090	CAP,E 4700-25 SMG	C209	87-010-186-080		CAP,CHIP 4700P
	C111	87-012-140-080	CAP 470P	C210	87-010-186-080		CAP,CHIP 4700P
	C113	87-010-247-080	CAP, ELECT 100-50V	C211	87-012-368-080		C-CAP,S 0.1-50 F
	C114	87-010-112-080	CAP, ELECT 100-16V	C212	87-012-368-080		C-CAP,S 0.1-50 F
	C115	87-010-235-080	CAP,E 470-16 SME	C213	87-010-195-080		C-CAP,S 0.068-25 F
	C132	87-010-260-080	CAP, ELECT 47-25V	C214	87-010-195-080		C-CAP,S 0.068-25 F
	C133	87-010-403-080	CAP, ELECT 3.3-50V	C215	87-010-544-080		CAP, ELECT 0.1-50V
	C151	87-010-196-080	CHIP CAPACITOR,0.1-25	C216	87-010-544-080		CAP, ELECT 0.1-50V
	C152	87-A11-174-090	CAP,E 4700-16 M SMG	C217	87-010-182-080		C-CAP,S 2200P-50 B
	C171	87-010-260-080	CAP, ELECT 47-25V	C218	87-010-182-080		C-CAP,S 2200P-50 B
	C172	87-010-260-080	CAP, ELECT 47-25V	C219	87-010-184-080		C-CAP,S 3300P-50 B
	C173	87-010-260-080	CAP, ELECT 47-25V	C220	87-010-184-080		C-CAP,S 3300P-50 B
	C174	87-010-260-080	CAP, ELECT 47-25V	C221	87-010-186-080		CAP,CHIP 4700P
	C175	87-010-247-080	CAP, ELECT 100-50V	C222	87-010-186-080		CAP,CHIP 4700P
	C176	87-010-263-080	CAP, ELECT 100-10V	C223	87-010-403-080		CAP, ELECT 3.3-50V
	C182	87-010-322-080	C-CAP,S 100P-50 J CH	C224	87-010-403-080		CAP, ELECT 3.3-50V

REF. NO	PART NO.	KANRI NO.	DESCRIPTION	REF. NO	PART NO.	KANRI NO.	DESCRIPTION
C225	87-012-157-080		C-CAP,S 330P-50 J CH	C755	87-012-286-080		CAP, U 0.01-25
C226	87-012-157-080		C-CAP,S 330P-50 J CH	C756	87-012-286-080		CAP, U 0.01-25
C265	87-010-546-080		CAP, ELECT 0.33-50V	C757	87-012-188-080		C-CAP,U 47P-50 CH
C266	87-010-546-080		CAP, ELECT 0.33-50V	C758	87-012-167-080		C-CAP,U 5P-50 CH
C271	87-015-819-080		CAPACITOR,0.01	C761	87-010-196-080		CHIP CAPACITOR,0.1-25
C277	87-010-197-080		CAP, CHIP 0.01 DM	C762	87-012-286-080		CAP, U 0.01-25
CN201	87-A60-812-010		CONN,8P V BLK TAC-L8P	C763	87-010-829-080		CAP, U 0.047-16
CN202	87-A60-812-010		CONN,8P V BLK TAC-L8P	C765	87-012-286-080		CAP, U 0.01-25
J203	87-YP6-608-010		TERMINAL,SPKR 4P	C766	87-010-197-080		CAP, CHIP 0.01 DM
L201	87-003-383-010		COIL,1UH-S	C768	87-012-286-080		CAP, U 0.01-25
L202	87-003-383-010		COIL,1UH-S	C769	87-010-260-080		CAP, ELECT 47-25V
R215	87-A00-258-080		RES,M/F 0.22-1W J	C770	87-010-829-080		CAP, U 0.047-16
R216	87-A00-258-080		RES,M/F 0.22-1W J	C771	87-010-383-080		CAP, ELECT 33-25V
R217	87-A00-258-080		RES,M/F 0.22-1W J	C772	87-010-829-080		CAP, U 0.047-16
R218	87-A00-258-080		RES,M/F 0.22-1W J	C773	87-010-196-080		CHIP CAPACITOR,0.1-25
R219	87-A00-258-080		RES,M/F 0.22-1W J	C774	87-010-263-080		CAP, ELECT 100-10V
R220	87-A00-258-080		RES,M/F 0.22-1W J	C775	87-010-404-080		CAP, ELECT 4.7-50V
TH201	87-A91-042-080		C-THMS,100K 55001	C776	87-012-286-080		CAP, U 0.01-25
TH202	87-A91-042-080		C-THMS,100K 55001	C777	87-010-493-080		CAP,E 0.47-50 GAS
				C778	87-010-401-080		CAP, ELECT 1-50V
MAIN PT C.B				C779	87-010-401-080		CAP, ELECT 1-50V
▲PR103	87-026-681-080		PROTECTOR,5A 60V 491	C780	87-010-196-080		CHIP CAPACITOR,0.1-25
▲PR104	87-026-681-080		PROTECTOR,5A 60V 491	C781	87-010-405-080		CAP, ELECT 10-50V
▲PR151	87-A90-094-080		PROTECTOR,4A 491SERIES 60V	C782	87-010-405-080		CAP, ELECT 10-50V
▲PT101	8Z-CL1-623-010		PT,E	C783	87-012-286-080		CAP, U 0.01-25
RY102	87-A90-976-010		RELAY,AC12V SDT-S-112LMR	C784	87-012-286-080		CAP, U 0.01-25
▲T101	87-A60-317-010		TERMINAL, 1P MSC	C785	87-010-405-080		CAP, ELECT 10-50V
▲T102	87-A60-317-010		TERMINAL, 1P MSC	C786	87-010-405-080		CAP, ELECT 10-50V
WH101	87-A90-460-010		HLDR,WIRE 2.5-7P	C787	87-012-275-080		C-CAP,U 1200P-50 B
				C788	87-012-275-080		C-CAP,U 1200P-50 B
SUB PT C.B				C789	87-012-275-080		C-CAP,U 1200P-50 B
				C790	87-012-275-080		C-CAP,U 1200P-50 B
▲PT102	8Z-CL1-673-010		PT,SUB ZCL-1(E)	C791	87-010-405-080		CAP, ELECT 10-50V
				C793	87-012-273-080		C-CAP,U 820P-50 B
				C794	87-010-406-080		CAP, ELECT 22-50
TU INF C.B				C795	87-010-596-080		CAP, S 0.047-16
				C796	87-010-403-080		CAP, ELECT 3.3-50V
C501	87-010-189-080		C-CAP,S 8200P-50 B	C797	87-012-276-080		CAP, CHIP SS 1500 PBK
C502	87-010-189-080		C-CAP,S 8200P-50 B	C798	87-012-276-080		CAP, CHIP SS 1500 PBK
CN115	87-A60-114-010		CONN,4P H S2M-4WR	C799	87-010-829-080		CAP, U 0.047-16
CN116	87-A60-077-010		CONN,10P H 9604S-10F				
CN117	87-A60-189-010		CONN,16P V TUC-P16P-B1<EZ>	C812	87-012-286-080		CAP, U 0.01-25
				C814	87-012-286-080		CAP, U 0.01-25
				C820	87-010-260-080		CAP, ELECT 47-25V
				C821	87-012-286-080		CAP, U 0.01-25
				C822	87-012-286-080		CAP, U 0.01-25
TUNER C.B				C823	87-012-286-080		CAP, U 0.01-25
C701	87-010-381-080		CAP, ELECT 330-16V	C828	87-010-196-080		CHIP CAPACITOR,0.1-25
C702	87-010-404-080		CAP, ELECT 4.7-50V	C829	87-010-196-080		CHIP CAPACITOR,0.1-25
C703	87-012-286-080		CAP, U 0.01-25	C859	87-012-286-080		CAP, U 0.01-25<EZ>
C704	87-012-286-080		CAP, U 0.01-25	C861	87-012-199-080		CAP 220P<EZ>
C709	87-012-195-080		C-CAP,U 100P-50CH				
C711	87-010-260-080		CAP, ELECT 47-25V	C862	87-012-199-080		CAP 220P<EZ>
C712	87-010-831-080		C-CAP,U,0.1-16F	C863	87-012-270-080		CAP, U 470P-50<EZ>
C713	87-012-286-080		CAP, U 0.01-25	C864	87-010-405-080		CAP, ELECT 10-50V<EZ>
C714	87-012-286-080		CAP, U 0.01-25	C865	87-010-196-080		CHIP CAPACITOR,0.1-25<EZ>
C715	87-012-195-080		C-CAP,U 100P-50CH	C866	87-010-405-080		CAP, ELECT 10-50V<EZ>
C717	87-012-286-080		CAP, U 0.01-25				
C719	87-012-286-080		CAP, U 0.01-25	C867	87-012-286-080		CAP, U 0.01-25<EZ>
C720	87-012-195-080		C-CAP,U 100P-50CH	C868	87-012-184-080		C-CAP,U 33P-50 CH<EZ>
C721	87-012-176-080		CAP 15P	C869	87-012-180-080		C-CAP,U 22P-50 CH<EZ>
C722	87-012-176-080		CAP 15P	C940	87-012-286-080		CAP, U 0.01-25
				C942	87-012-168-080		C-CAP,U 6P-50 CH
C723	87-012-274-080		CHIP CAP,U 1000P-50B				
C725	87-018-131-080		CAP, CER 1000P-50V	C947	87-012-286-080		CAP, U 0.01-25
C727	87-010-196-080		CHIP CAPACITOR,0.1-25	C949	87-A10-039-080		C-CAP,U 470P-50 J CH
C728	87-010-248-080		CAP, ELECT 220-10V	C952	87-012-286-080		CAP, U 0.01-25
C729	87-012-274-080		CHIP CAP,U 1000P-50B	C958	87-010-197-080		CAP, CHIP 0.01 DM
				C959	87-010-831-080		C-CAP,U,0.1-16F
C731	87-012-286-080		CAP, U 0.01-25				
C733	87-012-280-080		CAP, U 3300P-50	C960	87-010-196-080		CHIP CAPACITOR,0.1-25
C734	87-012-280-080		CAP, U 3300P-50	C962	87-010-401-080		CAP, ELECT 1-50V
C752	87-012-282-080		CAP, U 4700P-50	CF801	87-008-423-010		CERAMIC FILTER, SFE10.7
C753	87-012-195-080		C-CAP,U 100P-50CH	CF802	82-785-747-010		CF MS2 GHY R
				CN701	87-A60-700-010		CONN,13P H GRY TUC-P13X-C1<K>

REF. NO	PART NO.	KANRI NO.	DESCRIPTION	REF. NO	PART NO.	KANRI NO.	DESCRIPTION
CN701	87-A60-650-010		CONN,16P H GRY TUC-P16X-C1<EZ>	L941	87-A50-020-010		COIL,ANT LW(COI)
FFE801	A8-6ZA-191-130		6ZA-1 FEENM	L942	87-A50-019-010		COIL,OSC LW(COI)
J801	87-033-241-010		TERMINAL,ANT AJ-2039	L981	8Z-ZA1-665-010		COIL,AM PACK 2(TOK)
L771	87-A50-266-010		COIL,FM DET-2N(TOK)	TC942	87-011-164-010		CAPACITOR,TRIMMER 30P
L772	87-A91-110-010		FLTR,PCFJZH-450 (TOK)	X721	87-A70-061-010		VIB,XTAL 4.500MHZ CSA-309
L781	87-005-847-080		COIL,2.2UH(CECS)	X851	87-A70-091-010		VIB,XTAL 4.332MHZ CSA-309<EZ>
L791	87-A50-027-010		COIL,1 POLE MPX(TOK)				
L792	87-A50-027-010		COIL,1 POLE MPX(TOK)				
L832	87-005-847-080		COIL,2.2UH(CECS)				
L851	87-005-847-080		COIL,2.2UH(CECS)<EZ>				

- Regarding connectors, they are not stocked as they are not the initial order items. The connectors are available after they are supplied from connector manufacturers upon the order is received.

チップ抵抗部品コード/CHIP RESISTOR PART CODE

チップ抵抗部品コードの成り立ち

Chip Resistor Part Coding

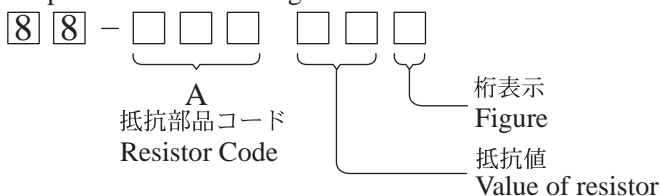

チップ抵抗 Chip resistor

容量 Wattage	種類 Type	許容誤差 Tolerance	記号 Symbol	寸法/Dimensions (mm)			抵抗コード : A Resistor Code : A	
				外形/Form	L	W		t
1/16W	1005	± 5%	CJ		1.0	0.5	0.35	104
1/16W	1608	± 5%	CJ		1.6	0.8	0.45	108
1/10W	2125	± 5%	CJ		2	1.25	0.45	118
1/8W	3216	± 5%	CJ		3.2	1.6	0.55	128

TRANSISTOR ILLUSTRATION

ECB	ECB	BCE	BCE	C
CSC4115	CC5551 CSD655 KTA1266 KTC3198	2SB1370 2SB1677 2SD2619	2SA1235 2SC2714 2SC3052 2SC3906 CMBT5401	CSD1306 RT1N141C RT1N144C RT1P141C RT1P144C
2SK543	2SK2158			

BLOCK DIAGRAM

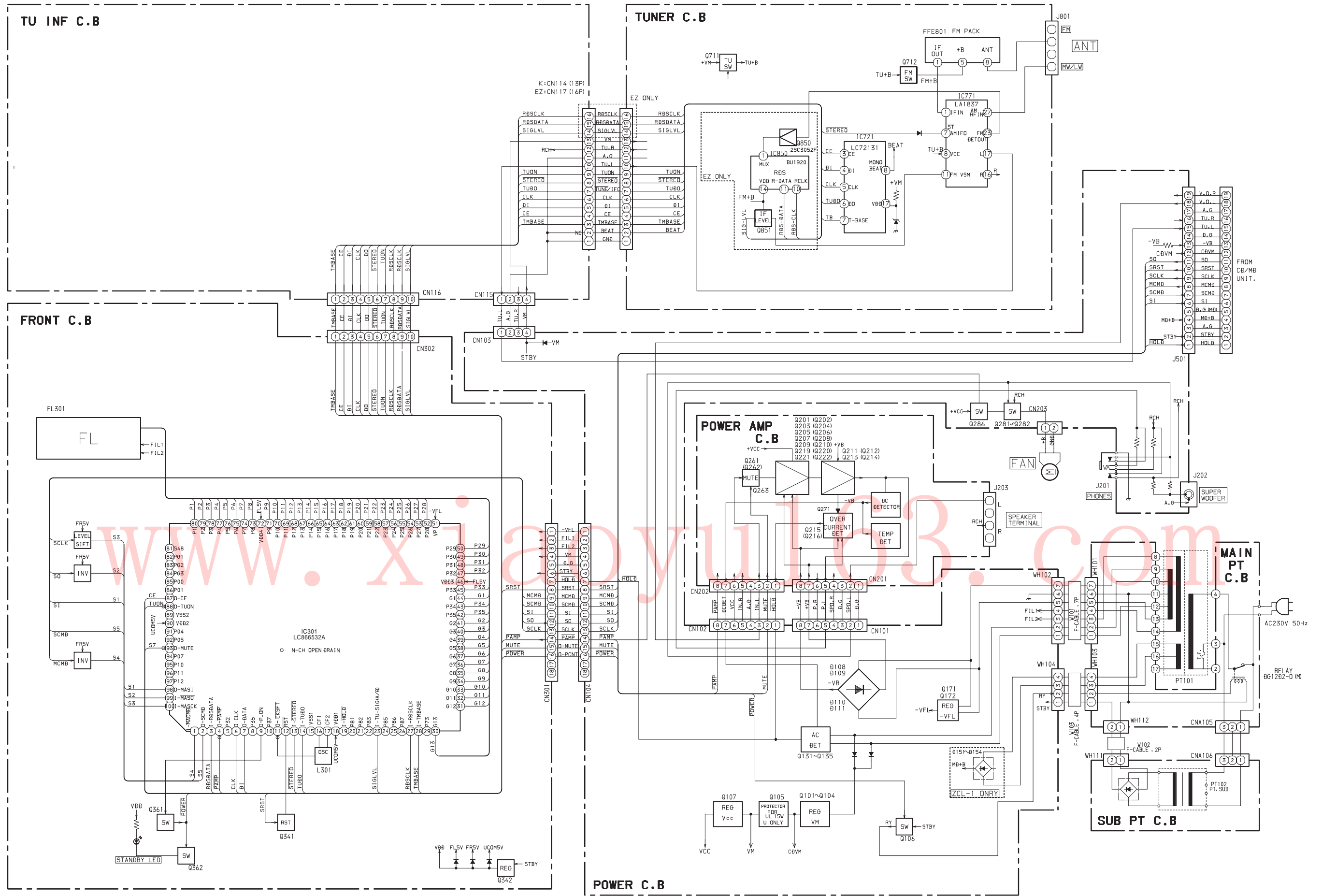

WIRING-1 (POWER AMP)

1 2 3 4 5 6 7 8 9 10 11 12 13 14

A
B
C
D
E
F
G
H
I
J
K

POWER C. B

SUB PT C. B

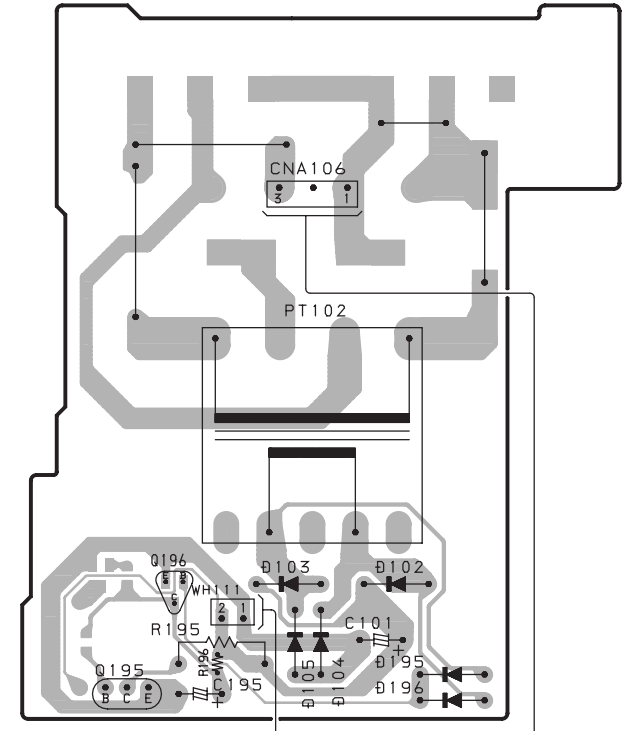
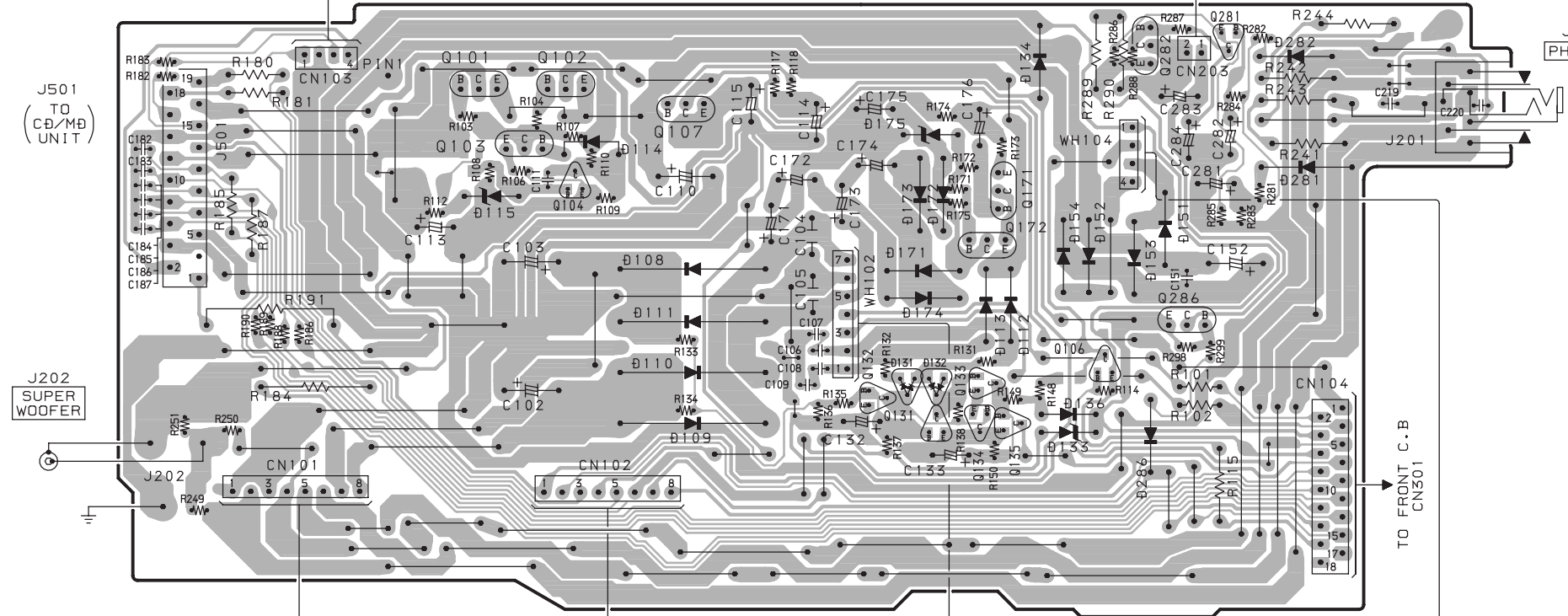

POWER AMP C. B

MAIN PT C. B

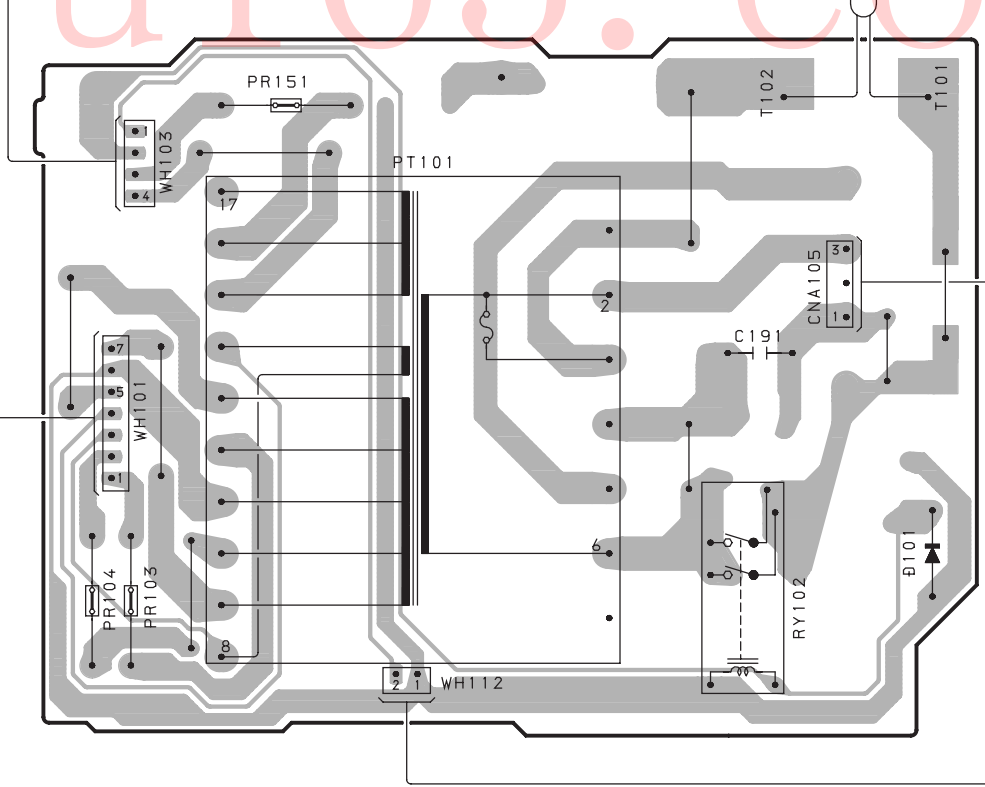
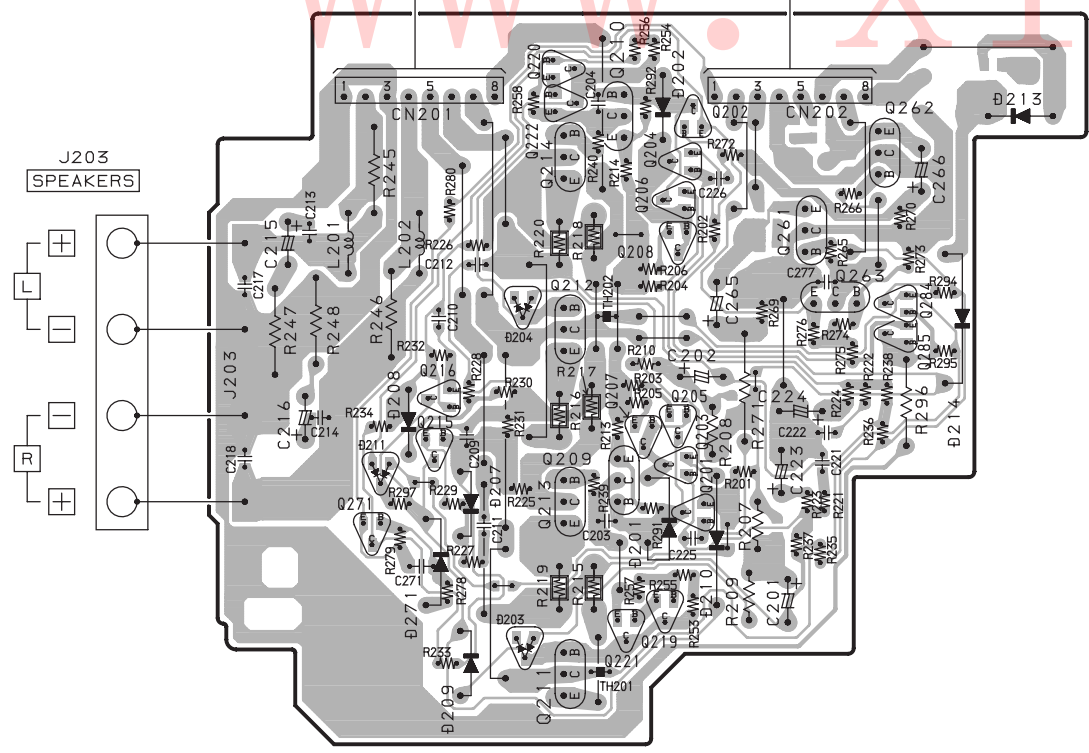

AC 230V 50Hz

SCHEMATIC DIAGRAM-1 (POWER AMP)

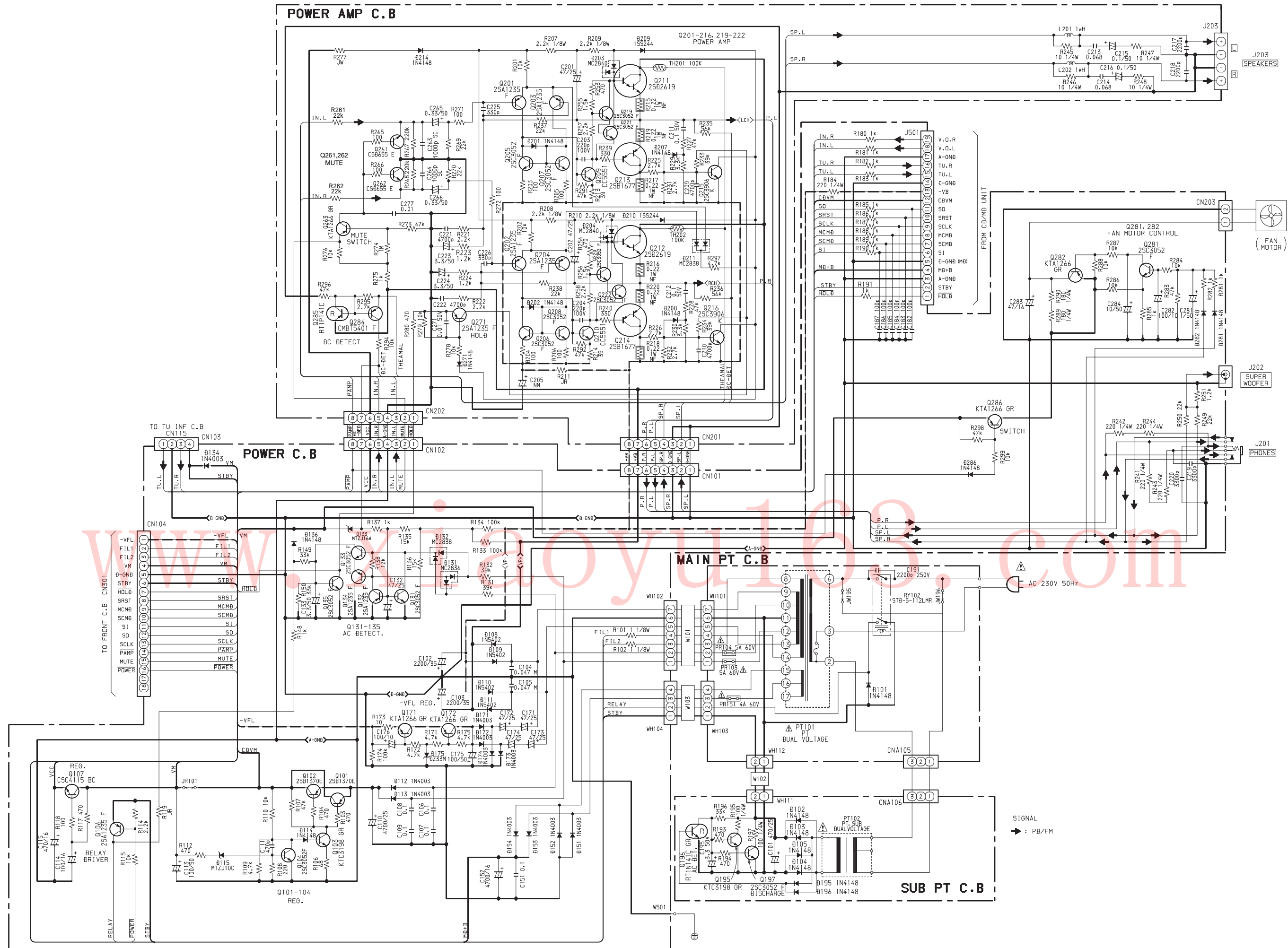

FRONT C.B

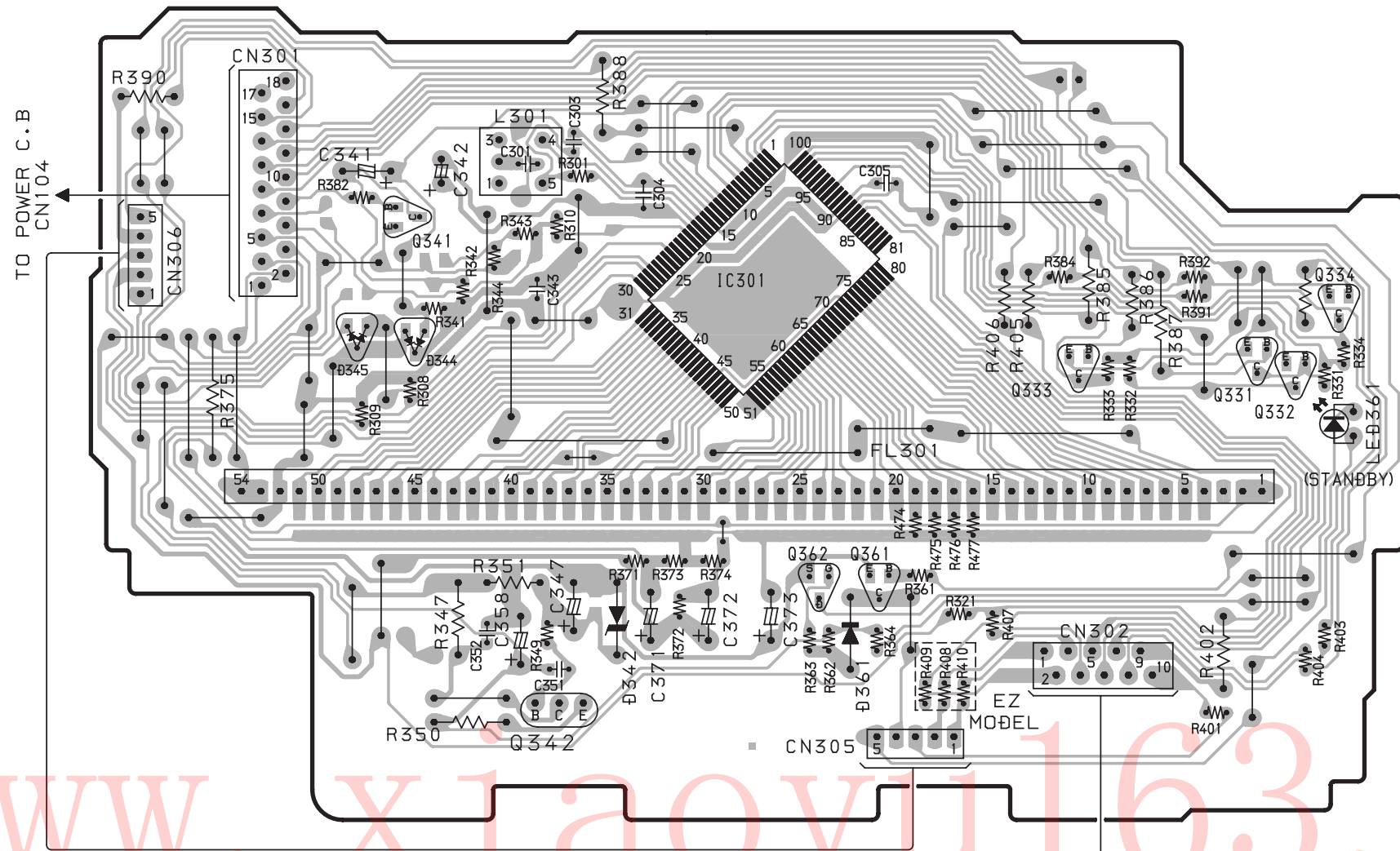

TU INF C.B

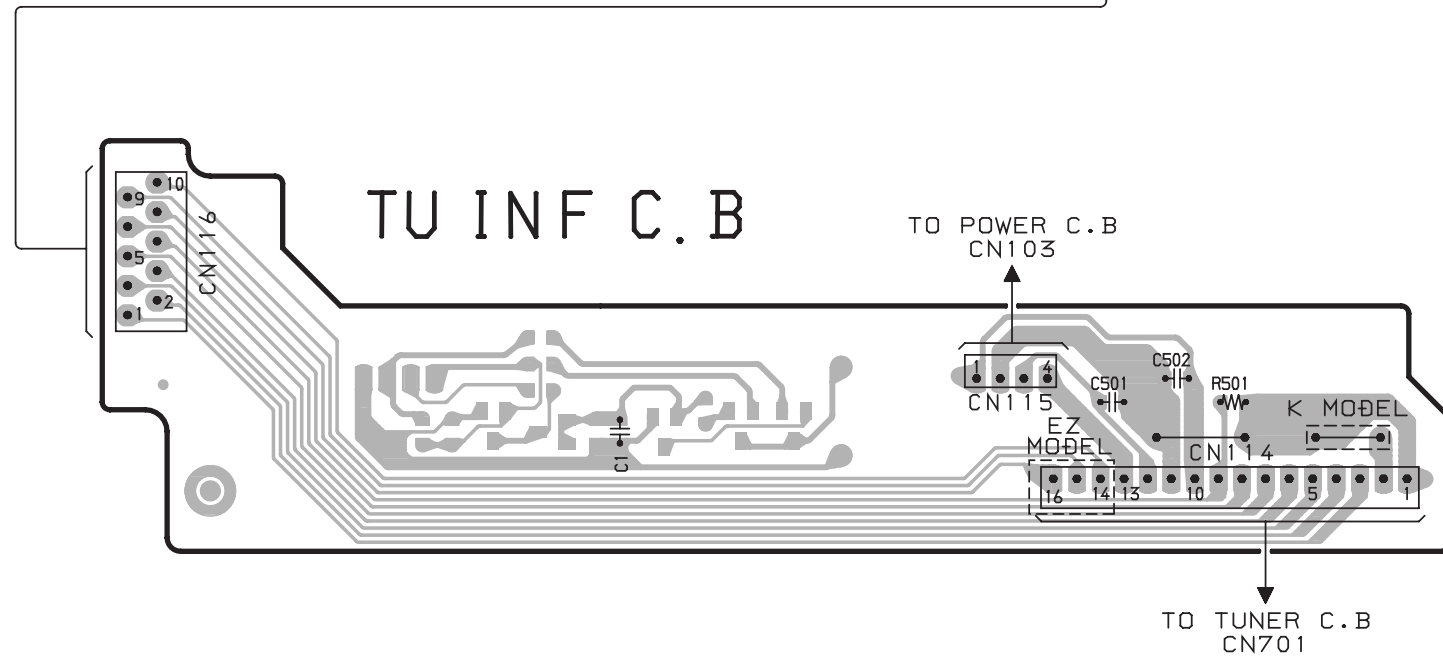

SCHEMATIC DIAGRAM-2 (FRONT)

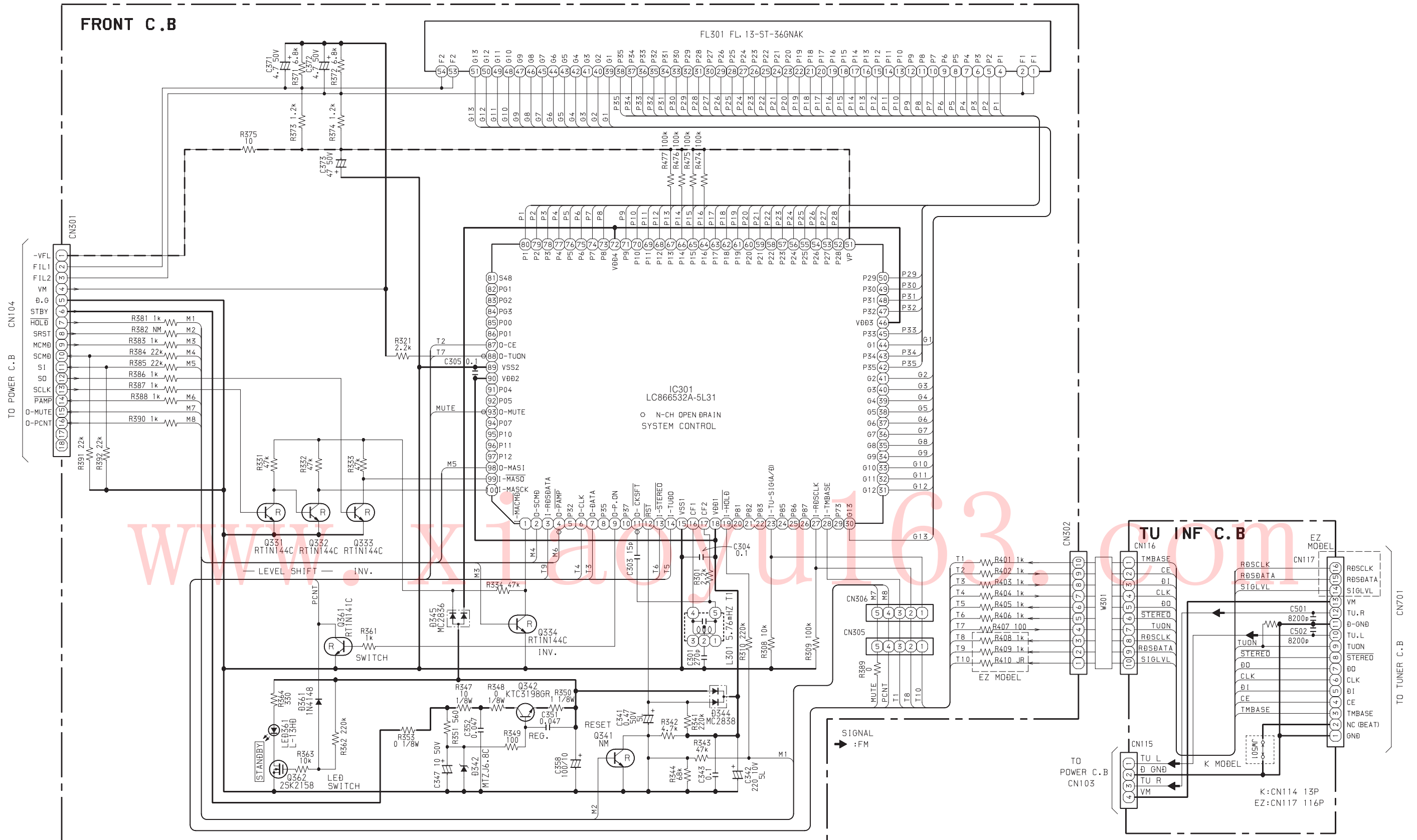

TUNER C.B

TO TU INF C.B
CN114 (K MODEL)
CN117 (EZ MODEL)

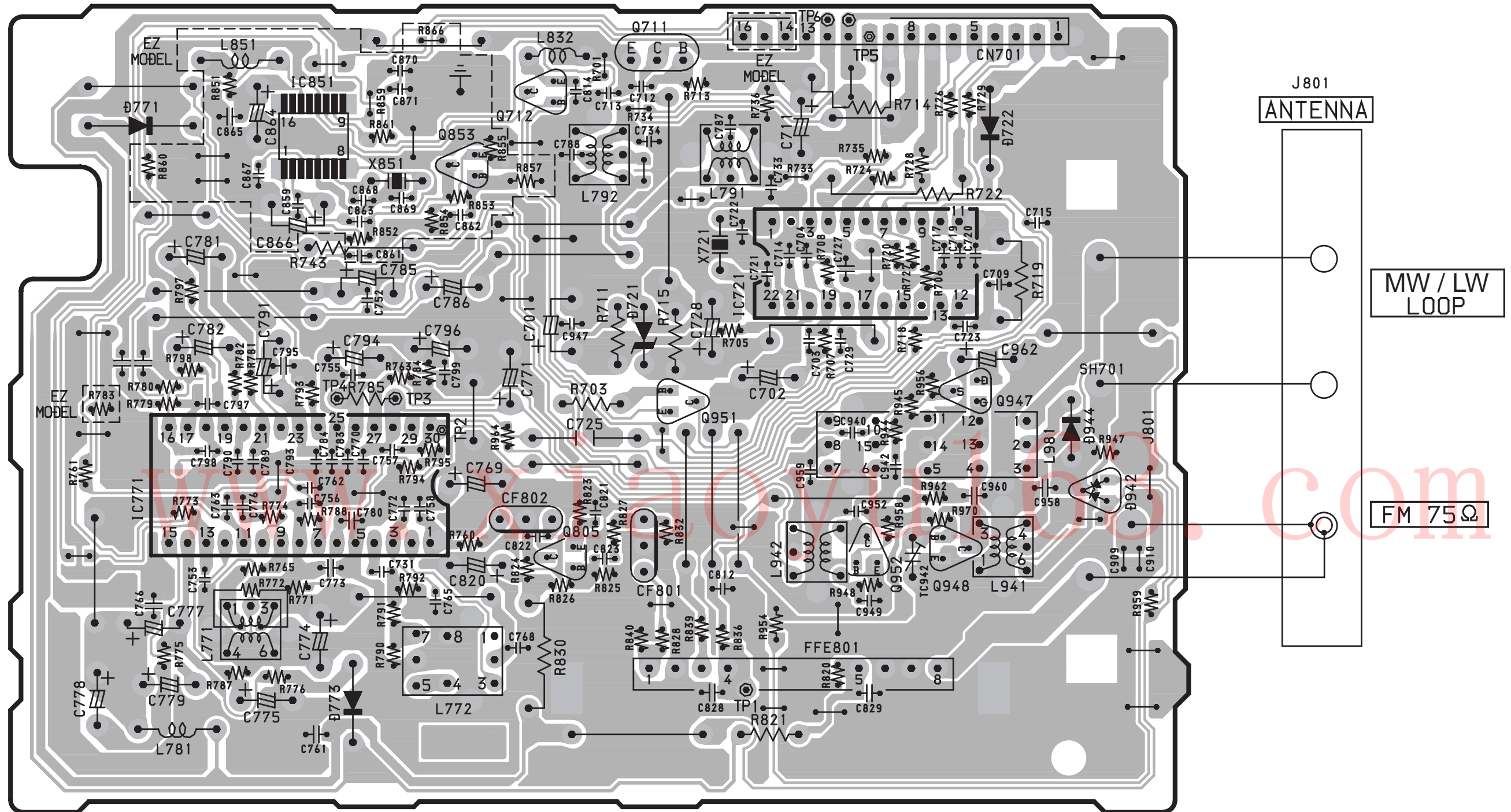

SCHEMATIC DIAGRAM-3 (TUNER)

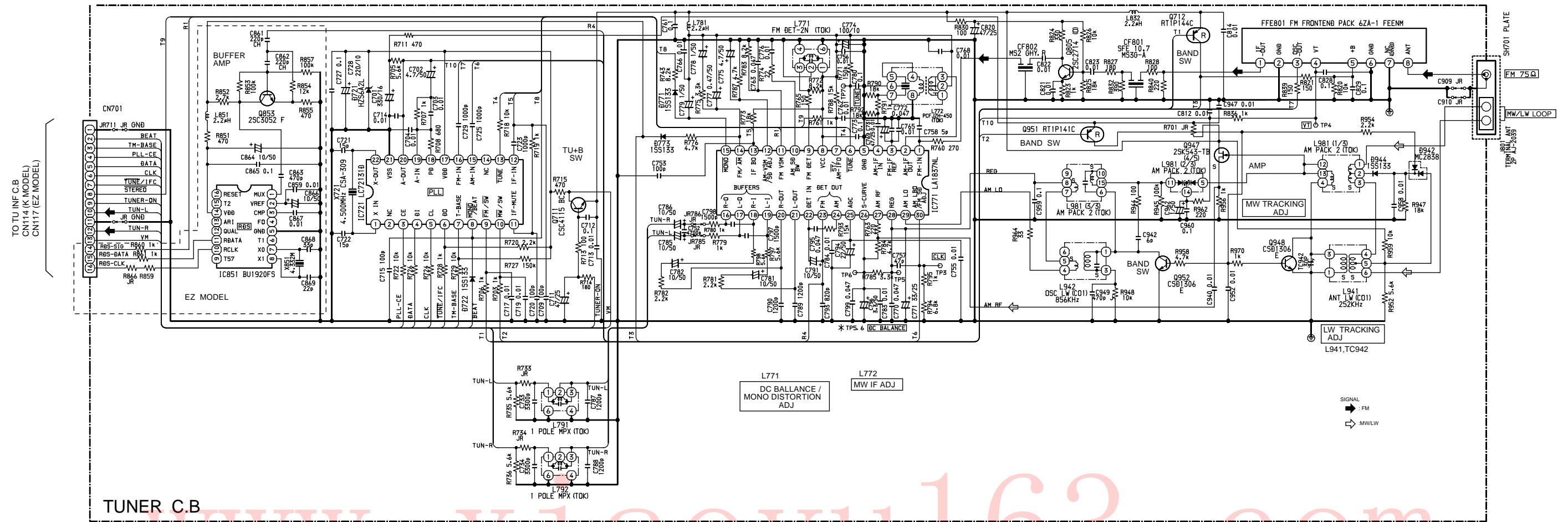

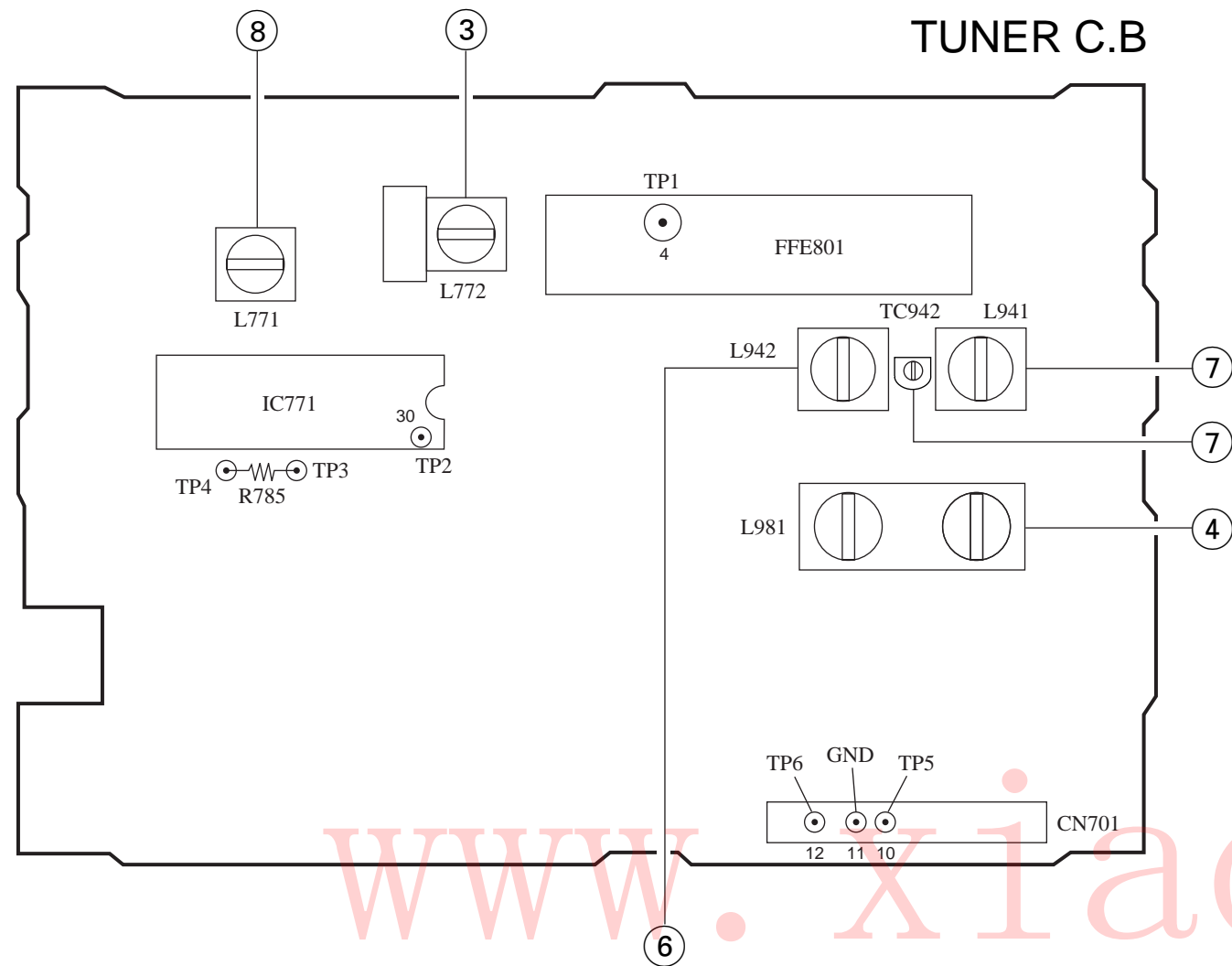

< TUNER SECTION >

1. Clock Frequency Check
 - Settings: • Test point: TP2 (CLK IC770 pin30)
 - Method: Set to MW 1602kHz and check that the test point becomes 2052kHz±45Hz (EZ).
2. MW VT Check
 - Settings: • Test point: TP1 (VT)
 - Method: Set to MW 1602kHz and check that the test point is less than 8.0V. Then set to MW 531kHz and check that the test point is more than 0.6V.
3. MW IF Adjustment
 - Settings: • Test point: TP5, TP6
 - L772 450kHz
4. MW Tracking Adjustment
 - Settings: • Test point: TP5, TP6
 - Adjustment location: L981
 - Method: Set to MW 999kHz and adjust L981 so that the test point becomes maximum.
5. FM VT Check
 - Settings: • Test point: TP1 (VT)
 - Method: Set to FM 87.5MHz, 108.0MHz and check that the test point is more than 0.5V (87.5MHz) and less than 8.0V (108.0MHz).
6. LW VT Adjustment
 - Settings: • Test point: TP2 (VT)
 - Adjustment location: L942
 - Method: Set to LW 144kHz and adjust L942 so that the test point becomes 1.3V±0.05V. Then set to LW 290kHz and check that the test point is less than 8.0V.
7. LW Tracking Adjustment
 - Settings: • Test point: TP5, TP6
 - Adjustment location:
 - L941 144kHz
 - TC942 290kHz
 - Method: Set up TC942 to center before adjustment. The level at 144kHz is adjusted to MAX by L941. Then the level at 290kHz is adjusted to MAX by TC942.
8. DC Balance/Mono Distortion Adjustment
 - Settings: • Test point: TP3, TP4
 - Adjustment location: L771
 - Input level: 54dB
 - Method: Set to FM 98.0MHz and adjust L771 so that the voltage between TP3 and TP4 becomes 0V±0.04V. Next, check that the distortion is less than 1.3%.

< TUNER SECTION >

- < FM SECTION >
- IHF Sensitivity: Less than 13dB (at 108.0/98.0MHz)
 - (THD 3%) Less than 14dB (at 98.0MHz)
 - Distortion: Less than 1.2% (98.0MHz)
 - Stereo separation: More than 12dB (98.0MHz)
 - Intermediate frequency: 10.7MHz
- < MW SECTION >
- Sensitivity: Less than 60dB (at 600kHz)
 - (S/N 20dB) Less than 58dB (at 1000/1400kHz)
 - Distortion: Less than 1.5% (at 1000kHz)
- < LW SECTION >
- Sensitivity: Less than 70dB (at 144kHz)
 - Less than 68dB (at 198kHz)
 - Less than 66dB (at 290kHz)

IC DESCRIPTION

IC, LC866532A-5L31RX

Pin No.	Pin Name	I/O	Description
1	I-MACMD	I	Command input from master microprocessor.
2	O-SCMD	O	Serial data output to master microprocessor.
3	I-RDSDATA	I	RDS data input.
4	O-PAMP	O	Power supply control output (power supply ON/OFF of POWER AMP).
5	P32	—	NC.
6	O-CLK	O	Connected to TUNER PLL IC LC72131 pin-⑤ CL.
7	O-DATA	O	Connected to TUNER PLL IC LC72131 pin-④ DI.
8	P35	—	NC.
9	O-P.ON	O	Power save mode control output
10	P37	—	NC.
11	O-CKSFT	O	Clock shift output. "L" at clock shift.
12	RST	I	Microprocessor reset.
13	I-STEREO	I	TUNER, STEREO detection.
14	I-TUDO	I	Connected to TUNER PLL IC LC72131 pin-⑥ D0.
15	VSS1	—	GND.
16	CF1	I	5.76 MHz. Connected to oscillator.
17	CF2	O	
18	VDD1	—	Microprocessor power supply (μ -com 5V).
19	I-HOLD	I	Hold state detection. (Ignored by slave microprocessor)
20-22	P81-P83	—	NC.
23	I-TU-SIG	I	RDS signal level AD value input (A/D).
24-26	P85-P87	—	NC.
27	I-RDSCCLK	I	RDS CLK input.
28	I-TMBASE	I	Reference clock input for watch. Connected to PLL ICLC72131 pin-⑦.
29	P73	—	NC.
30-41	G13-G2	O	FL tube grid output. (13G-2G).
42, 43	P35, P34	O	FL tube anode output. (P35, P34).
44	G1	O	FL tube grid output. (1G).
45	P33	O	FL tube anode output. (P33).
46	VDD3	—	Microprocessor power supply. (μ -com 5V).
47-50	P32-P29	O	FL tube anode output. (P32-P29).
51	VP	—	Connected to minus power supply -VFL for FL.
52-71	P28-P9	O	FL tube anode output. (P28-P9).
72	VDD4	—	Microprocessor power supply. (μ -com 5V).
73-80	P8-P1	O	FL tube anode output. (P8-P1).
81	S48	—	NC.
82-84	PG1-PG3	—	
85, 86	P00, P01	—	
87	O-CE	O	Connected to TUNER PLL IC LC72131 pin-③ CE.
88	O-TUON	O	TUNER power supply. ON/OFF output.
89	VSS2	—	GND.

Pin No.	Pin Name	I/O	Description
90	VDD2	—	Microprocessor power supply. (μ -com 5V).
91, 92	P04, P05	—	NC.
93	O-MUTE	O	Main mute output.
94	P07	—	NC.
95-97	P10-12	—	
98	O-MASI	O	Serial data output to master microprocessor.
99	$\overline{\text{I-MASO}}$	I	Serial data input from master microprocessor.
100	I-MACLK	I	Transfer clock input from master microprocessor.

www.xiaoyu163.com

IC BLOCK DIAGRAM
IC, BU1920FS

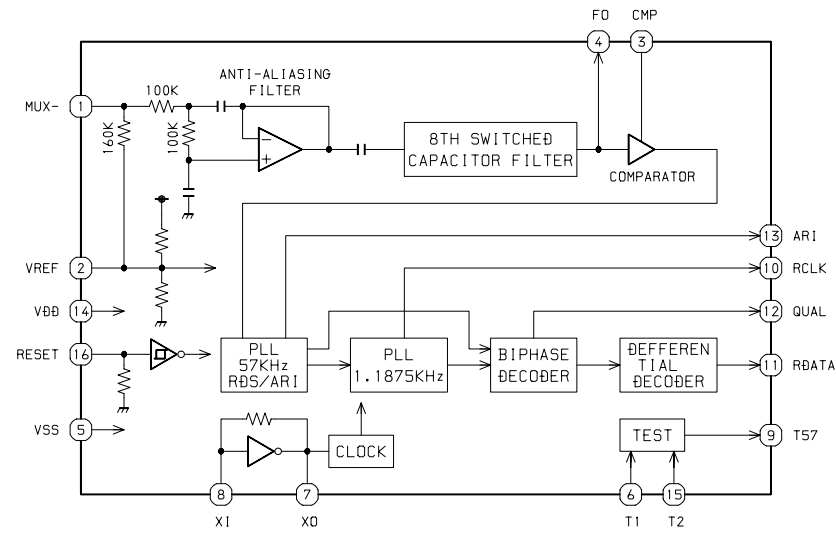

IC, LA1837

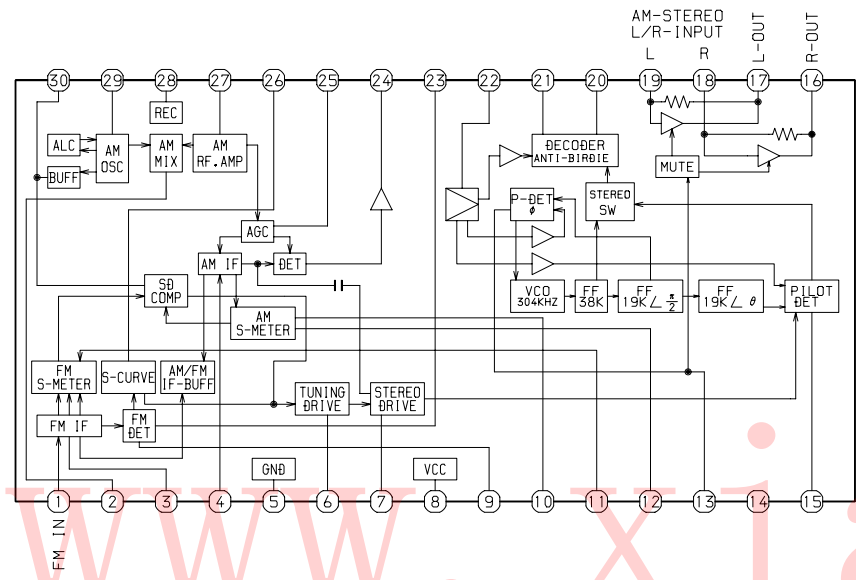

IC, LC72131

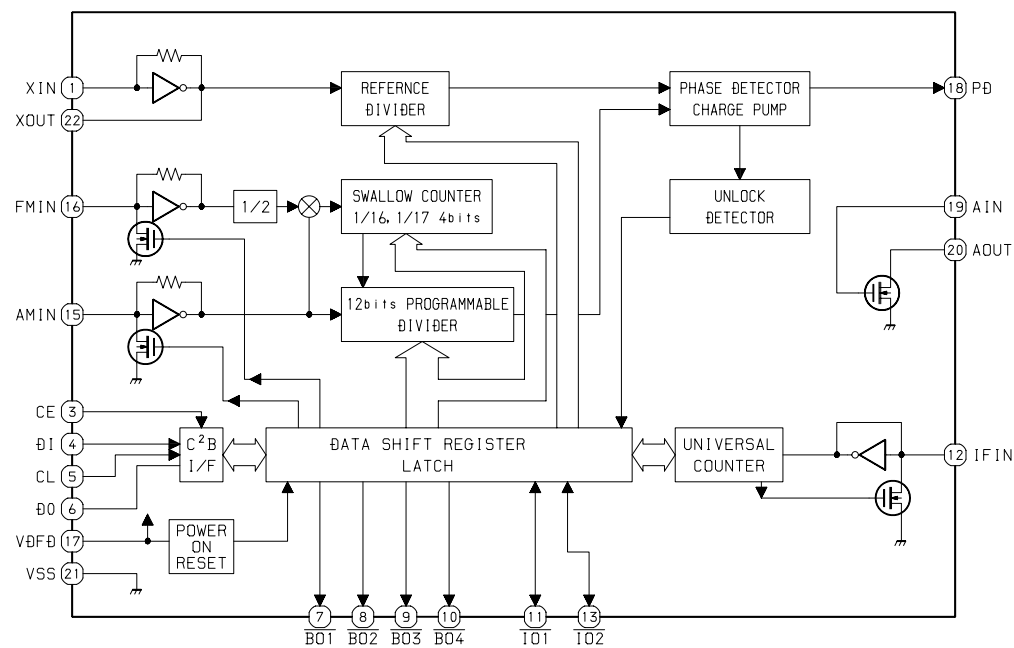

FL (13-ST-36GNAK) GRID ASSIGNMENT/ANODE CONNECTION

GRID ASSIGNMENT

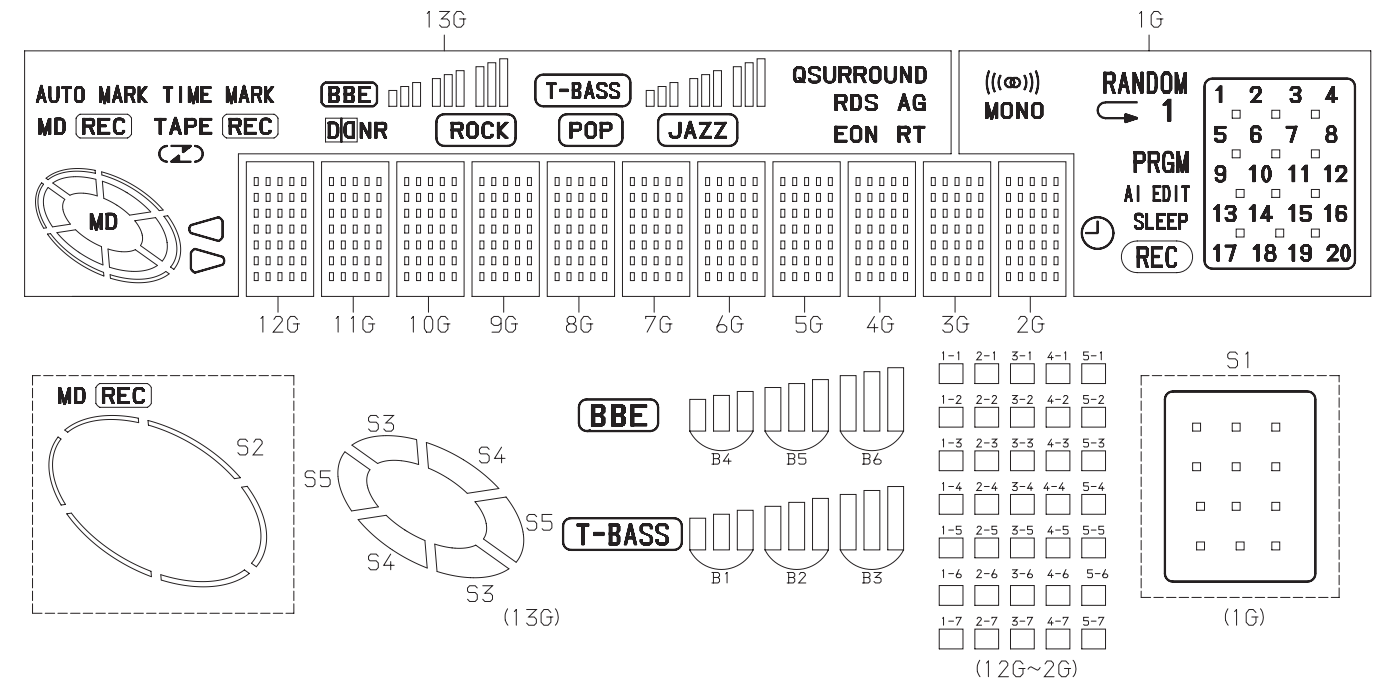

ANODE CONNECTION

	13G	12G~2G	1G		13G	12G~2G	1G
P1	JAZZ	1-1	1	P19	↷	4-4	8
P2	POP	2-1	↶	P20	↘	5-4	9
P3	ROCK	3-1	MONO	P21	↶	1-5	10
P4	DO NR	4-1	RANDOM	P22	TAPEREC	2-5	11
P5	RT	5-1	(((∞)))	P23	S2	3-5	12
P6	EON	1-2	PRGM	P24	S3	4-5	13
P7	AG	2-2	AI	P25	S4	5-5	14
P8	RDS	3-2	EDIT	P26	S5	1-6	15
P9	B1	4-2	SLEEP	P27	MD	2-6	16
P10	B2	5-2	⌚	P28	TIME MARK	3-6	17
P11	B3	1-3	REC	P29	AUTO MARK	4-6	18
P12	T-BASS	2-3	(CALENDAR) 1	P30	QSURROUND	5-6	19
P13	B4	3-3	2	P31	-	1-7	20
P14	B5	4-3	3	P32	-	2-7	S1
P15	B6	5-3	4	P33	-	3-7	-
P16	BBE	1-4	5	P34	-	4-7	-
P17	↷	2-4	6	P35	-	5-7	-
P18	↘	3-4	7				

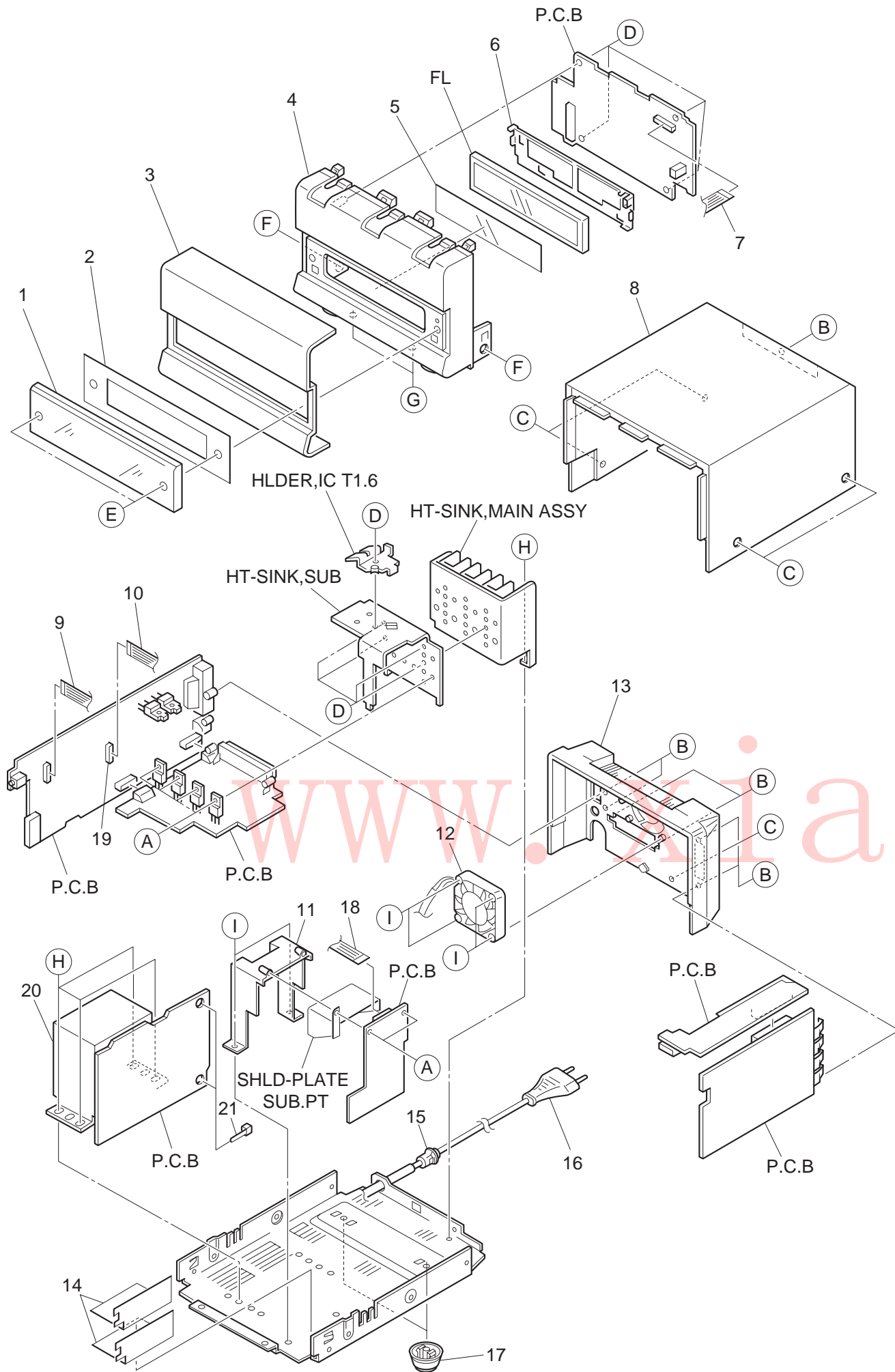

MECHANICAL PARTS LIST 1/1

DESCRIPTIONで判断できない物は "REFERENCE NAME LIST" を参照してください。
If can't understand for Description please kindly refer to "REFERENCE NAME LIST".

REF. NO	PART NO.	KANRI NO.	DESCRIPTION	REF. NO	PART NO.	KANRI NO.	DESCRIPTION
1	8Z-CL1-056-010		WINDOW,DISP EX<200KS>	18	8Z-CL1-654-010		F-CABLE,2P 2.5 170MM SUBPT
1	8Z-CL1-055-010		WINDOW,DISP EZ<201Ezs>	19	87-A90-460-010		HLD, WIRE 2.5-7P
2	8Z-CL1-031-010		PLATE, FL	20	8Z-CL1-623-010		PT, E
3	8Z-CL1-041-010		PANEL,FR RX EZ<201Ezs>	A	87-067-579-010		BVT2+3-8 W/O SLOT
4	8Z-CL1-001-010		CABI,FR RX	B	87-744-095-410		UT2+3-8 W/O SLOT CR2
5	8Z-CL1-030-010		PLATE,WINDOW RX	C	87-B10-068-010		UTT2+3-6 W/O SLOT CR
6	8Z-CL1-204-010		HLD, FL	D	87-067-703-010		TAPPING SCREW, BVT2+3-10
7	88-910-131-110		FF-CABLE,10P 1.25	E	8Z-CL1-034-010		S-SCREW,ZCL1
8	8Z-CL1-003-010		CABI, TOP RX	F	87-591-094-010		QIT+3-6 GOLD
9	8Z-CL1-655-010		F-CABLE, 4P 2.5 100MM PWR	G	87-067-761-010		TAPPING SCREW, BVT2+3-10
10	8Z-CL1-656-010		F-CABLE, 7P 2.5 150MM PWR	H	87-067-585-010		TAPPING SCREW, BVTT+4-6
11	8Z-CL1-203-010		HLD, SUB PT	I	87-751-095-410		UT2+3-8
12	8Z-CL1-663-010		FAN, MF40D-12-200MM				
13	8Z-CL1-052-010		PANEL, REAR RX E<201Ezs>				
13	8Z-CL1-042-010		PANEL, REAR RX K<200KS>				
14	8Z-CL1-213-010		COVER, PWB AC				
15	87-085-185-010		BUSHING, AC CORD (E)				
16	87-A80-092-010		AC CORD ASSY, E BLK SUN FAI<201Ezs>				
16	87-A80-007-010		AC CORD ASSY, K BLK<200KS>				
17	81-669-025-010		FOOT, H11				

COLOR NAME TABLE

Basic color symbol	Color	Basic color symbol	Color	Basic color symbol	Color
B	Black	C	Cream	D	Orange
G	Green	H	Gray	L	Blue
LT	Transparent Blue	N	Gold	P	Pink
R	Red	S	Silver	ST	Titan Silver
T	Brown	V	Violet	W	White
WT	Transparent White	Y	Yellow	YT	Transparent Yellow
LM	Metallic Blue	LL	Light Blue	GT	Transparent Green
LD	Dark Blue	DT	Transparent Orange		

MODEL NO. FM-LMD200/LMD201

ELECTRICAL MAIN PARTS LIST

DESCRIPTIONで判断できない物は "REFERENCE NAME LIST" を参照してください。
 If can't understand for Description please kindly refer to "REFERENCE NAME LIST".

REF. NO	PART NO.	KANRI NO.	DESCRIPTION	REF. NO	PART NO.	KANRI NO.	DESCRIPTION
IC				C6	87-010-553-040		CAP,E 47-16 GAS
	87-A20-707-010	C-IC, CXA2523AR		C7	87-012-349-080		C-CAP,S 1000P-50 CH
	87-A20-708-010	C-IC, CXD2652AR		C8	87-010-198-080		CAP, CHIP 0.022
	87-A20-709-040	C-IC, BD7910FV		C9	87-010-264-040		CAP,E 100-10
	87-ZG9-607-010	C-IC, CXP81952M-523R		C10	87-010-264-040		CAP,E 100-10
	87-ZG9-606-040	C-IC, MN41V4400SJ-08		C12	87-010-494-040		CAP,E 1-50 GAS
	87-A20-755-080	C-IC, AK93C45AF		C13	87-010-193-080		CHIP CAPACITOR, 0.033
	87-A20-710-040	C-IC, S-8110AMP		C14	87-010-560-040		CAP,E 10-50 GAS
	87-A20-711-040	C-IC, BA5970FP		C16	87-010-491-040		CAP,E 0.22-50 GAS
	87-A20-712-040	C-IC, BA6417F		C17	87-012-349-080		C-CAP,S 1000P-50 CH
	87-A21-110-040	C-IC, AK4519VF		C18	87-010-213-080		C-CAP,S 0.015-50 B
	87-017-853-040	IC, NJM2100V		C20	87-010-193-080		CHIP CAPACITOR, 0.033
	87-A20-797-040	C-IC, NJU7221U30		C22	87-010-184-080		CHIP CAPACITOR 3300P(K)
	87-A20-798-040	C-IC, NJU7221U35		C23	87-010-992-080		C-CAP,S 0.047-50 B
	87-A20-714-040	C-IC, NJM2370U33		C25	87-012-349-080		C-CAP,S 1000P-50 CH
	87-A20-446-010	C-IC, LA9241ML		C27	87-010-176-080		C-CAP,S 680P-50 SL
	87-A20-459-010	C-IC, LC78622ED		C29	87-010-186-080		CAP,CHIP 4700P
	87-A20-445-010	IC, BA5936		C30	87-012-156-080		C-CAP,S 220P-50 CH
	8Z-CL1-628-010	C-IC, LC866548-5M36		C31	87-010-493-040		CAP,E 0.47-50 GAS
	87-A20-914-010	IC, SPS-442-1-F		C32	87-010-553-040		CAP,E 47-16 GAS
	87-A20-870-010	IC, GP1F37R		C33	87-010-494-040		CAP,E 1-50 GAS
	87-A21-175-040	C-IC, TC74VHC14FT		C34	87-010-184-080		CHIP CAPACITOR 3300P(K)
	87-A21-111-040	C-IC, M62495FP		C35	87-010-197-080		CAP, CHIP 0.01 DM
	87-A21-022-040	C-IC, BA3880FS		C36	87-010-553-040		CAP,E 47-16 GAS
	87-A21-103-040	C-IC, MM1454XFBE		C37	87-010-404-040		CAP,E 4.7-50
	87-017-888-080	IC, NJM4558MD		C38	87-010-196-080		CHIP CAPACITOR, 0.1-25
TRANSISTOR				C40	87-010-145-080		C-CAP,S 1P-50 CH
	87-026-463-080	TR, 2SA933S (0.3W)		C42	87-010-315-080		C-CAP,S 27P-50 CH
	87-026-239-080	TR, DTC114TK (0.2W)		C45	87-010-196-080		CHIP CAPACITOR, 0.1-25
	89-113-184-080	TR, 2SA1318T		C46	87-010-196-080		CHIP CAPACITOR, 0.1-25
	87-026-297-080	TR, DTA144TK		C47	87-010-196-080		CHIP CAPACITOR, 0.1-25
	87-A30-047-080	TR, CSD655E		C48	87-010-315-080		C-CAP,S 27P-50 CH
	87-A30-075-080	C-TR, 2SA1235F		C50	87-012-140-080		CAP 470P
	87-026-610-080	TR, KTC3198GR		C51	87-012-156-080		C-CAP,S 220P-50 CH
	87-A30-083-080	TR, CSD1489B		C52	87-012-140-080		CAP 470P
	87-A30-071-080	C-TR, RT1N 144C		C55	87-010-264-040		CAP,E 100-10
	87-A30-087-080	C-FET, 2SK2158		C57	87-010-316-080		C-CAP,S 33P-50 CH
	89-327-143-080	TR, 2SC2714 (0.1W)		C58	87-010-316-080		C-CAP,S 33P-50 CH
	87-A30-074-080	C-TR, RT1P 141C		C59	87-010-264-040		CAP,E 100-10
	89-213-702-010	TR, 2SB1370 (1.8W)		C60	87-010-196-080		CHIP CAPACITOR, 0.1-25
	87-A30-152-080	TR, 2SC5395F		C61	87-010-196-080		CHIP CAPACITOR, 0.1-25
	87-026-423-080	C-TR RN2305		C62	87-010-370-040		CAP,E 330-6.3 SME
	89-115-884-080	CHIP -TRANSISTER 2SA1588Y		C65	87-010-497-040		CAP,E 4.7-35 GAS
	89-341-164-080	CHIP-TRANSISTOR, 2SC4116 Y		C66	87-010-196-080		CHIP CAPACITOR, 0.1-25
	87-026-412-080	C-TR RN1305		C67	87-010-264-040		CAP,E 100-10
DIODE				C68	87-010-322-080		C-CAP,S 100P-50 CH
	87-020-465-080	DIODE, 1SS133 (110MA)		C75	87-010-197-080		CAP, CHIP 0.01 DM
	87-A40-270-080	C-DIODE, MC2838		C76	87-A10-102-080		CAP,E 1000-10 REA
	87-A40-509-080	ZENER, MTZJ6.8C		C79	87-010-264-040		CAP,E 100-10
	87-070-274-080	DIODE, 1N4003 SEM		C80	87-010-197-080		CAP, CHIP 0.01 DM
	87-A40-269-080	C-DIODE, MC2836		C81	87-010-560-040		CAP,E 10-50 GAS
	87-A40-299-080	ZENER, DZ5.1M		C82	87-010-560-040		CAP,E 10-50 GAS
	87-017-083-080	ZENER, HZS4C2		C83	87-012-157-080		C-CAP,S 330P-50 CH
	87-A40-292-080	ZENER, DZ2.7L		C84	87-012-157-080		C-CAP,S 330P-50 CH
	87-001-731-080	ZENER, HZS6C2L		C93	87-010-197-080		CAP, CHIP 0.01 DM
	87-001-166-080	DIODE, 1SS301		C94	87-010-197-080		CAP, CHIP 0.01 DM
	87-A40-412-040	C-DIODE, SB05-05CP		C98	87-012-154-080		C-CAP,S 150P-50 CH
CD C.B				C102	87-010-322-080		C-CAP,S 100P-50 CH
C1	87-010-496-040	CAP,E 3.3-50 GAS		C104	87-010-322-080		C-CAP,S 100P-50 CH
C2	87-010-197-080	CAP, CHIP 0.01 DM		C105	87-010-322-080		C-CAP,S 100P-50 CH
C3	87-010-264-040	CAP,E 100-10		C110	87-010-196-080		CHIP CAPACITOR, 0.1-25
C4	87-A10-189-040	CAP,E 220-10		C141	87-010-992-080		C-CAP,S 0.047-25
C5	87-010-197-080	CAP, CHIP 0.01 DM		C146	87-010-498-040		CAP,E 10-16 M 5L
				C201	87-012-145-080		CAP, CHIP S 270P CH
				C203	87-010-312-080		C-CAP,S 15P-50 CH
				C204	87-015-785-080		CHIP CAPACITOR, 0.1FZ-25Z
				C205	87-010-196-080		CHIP CAPACITOR, 0.1-25
				C210	87-012-349-080		C-CAP,S 1000P-50 CH
				C217	87-010-498-040		CAP,E 10-16 GAS
				C220	87-010-197-080		CAP, CHIP 0.01 DM

REF. NO	PART NO.	KANRI NO.	DESCRIPTION	REF. NO	PART NO.	KANRI NO.	DESCRIPTION
C221	87-010-235-080		CAP,E 470-16 SME	C612	87-010-197-080		CAP, CHIP 0.01 DM
C222	87-010-101-080		CAP, ELECT 220-16	C621	87-010-401-080		CAP, ELECT 1-50V
C223	87-010-381-080		CAP, ELECT 330-16V	C622	87-010-401-080		CAP, ELECT 1-50V
C241	87-010-493-040		CAP,E 0.47-50 GAS	C653	87-010-404-040		CAP,E 4.7-50
C242	87-A10-759-040		CAP,E 330-6.3 SRM	C654	87-010-404-040		CAP,E 4.7-50
C243	87-010-196-080		CHIP CAPACITOR,0.1-25	C655	87-010-404-040		CAP,E 4.7-50
C246	87-010-197-080		CAP, CHIP 0.01 DM	C656	87-010-404-040		CAP,E 4.7-50
C251	87-010-194-080		CAP, CHIP 0.047	C657	87-010-188-080		CAP,CHIP 6800P
C252	87-010-194-080		CAP, CHIP 0.047	C658	87-010-188-080		CAP,CHIP 6800P
C254	87-010-264-040		CAP,E 100-10	C659	87-012-140-080		CAP 470P
C271	87-010-196-080		CHIP CAPACITOR,0.1-25	C660	87-012-140-080		CAP 470P
C354	87-010-495-040		CAP,E 2.2-50 GAS	C662	87-010-260-080		CAP, ELECT 47-25V
C401	87-010-178-080		CHIP CAP 1000P	C665	87-010-197-080		CAP, CHIP 0.01 DM
C402	87-010-178-080		CHIP CAP 1000P	C666	87-010-197-080		CAP, CHIP 0.01 DM
C403	87-010-196-080		CHIP CAPACITOR,0.1-25	C667	87-010-598-080		C-CAP,S 0.068-16VRK
C404	87-010-196-080		CHIP CAPACITOR,0.1-25	C668	87-010-598-080		C-CAP,S 0.068-16VRK
C411	87-012-140-080		CAP 470P	C669	87-010-260-080		CAP, ELECT 47-25V
C413	87-010-982-040		CAP,E 33-25 GAS	C670	87-010-196-080		CHIP CAPACITOR,0.1-25
C414	87-010-982-040		CAP,E 33-25 GAS	C671	87-010-404-040		CAP,E 4.7-50
C431	87-010-497-040		CAP,E 4.7-35 GAS	C672	87-010-404-040		CAP,E 4.7-50
C432	87-010-497-040		CAP,E 4.7-35 GAS	C677	87-010-404-040		CAP,E 4.7-50
C473	87-010-221-080		CAP,E 470-10 SME	C678	87-010-404-040		CAP,E 4.7-50
C474	87-010-197-080		CAP, CHIP 0.01 DM	C721	87-010-401-080		CAP, ELECT 1-50V
CN1	87-A60-429-010		CONN,16P H TOC-A	C722	87-010-401-080		CAP, ELECT 1-50V
CN2	87-009-411-010		CONN,6P ZH V	C723	87-012-154-080		C-CAP,S 150P-50 CH
CN3	87-A60-111-010		CONN,5P V S2M 5W	C724	87-012-154-080		C-CAP,S 150P-50 CH
CN202	87-A60-826-010		CONN,6P B TMC-D(X)	C725	87-012-154-080		C-CAP,S 150P-50 CH
CN203	87-099-558-010		CONN,12P TUC-P12X-B1	C726	87-012-154-080		C-CAP,S 150P-50 CH
CN204	87-099-670-010		CONN,9P TUC-P9X-B1	C727	87-010-404-080		CAP, ELECT 4.7-50V
CN205	87-099-554-010		CONN,6P TUC-P6X-B1	C728	87-010-404-080		CAP, ELECT 4.7-50V
CN401	87-A60-423-010		CONN,14P V TOC-B	C733	87-010-197-080		CAP, CHIP 0.01 DM
CN402	87-A60-476-010		CONN,8P H 6232 RADIP	C734	87-010-381-080		CAP, ELECT 330-16V
L1	87-003-102-080		COIL, 10UH	C735	87-010-197-080		CAP, CHIP 0.01 DM
L4	87-003-152-080		COIL, 100UH	CN503	87-099-569-010		CONN,12P TUC-P12P-B1
L5	87-003-152-080		COIL, 100UH	CN504	87-099-668-010		CONN,9P TUC-P 9P-B1
L201	87-A50-052-010		COIL,CLOCK 5.76MHZ T1	J501	82-MA2-631-010		JACK PIN 4P RVS
SFR130	87-A90-787-080		SFR,100K H HOKU	J701	87-A60-354-010		JACK,PIN 2P MSP -242V-05
W201	82-CL1-653-010		F-CABLE,19P 1.5 FG				
WH201	87-A90-878-010		HLDL,WIRE 19P 1.5 51016				
X1	87-A70-046-010		VIB,XTAL 16.934MHZ				
				POWER C.B			
				C90	87-018-211-080		CAP, CER 0.01-50
				C91	87-010-408-080		CAP, ELECT 47-50V
				C92	87-010-382-080		CAP, ELECT 22-25V
				C453	87-018-209-080		CAP, CER 0.1-50V
				C454	87-010-252-080		CAP, ELECT 1000-6.3V
				C455	87-010-235-080		CAP,E 470-16 SME
				CN402	87-099-565-010		CONN,6P TUC-P4P-B1
FUNC C.B				KEY C.B			
C351	87-012-142-080		CAP, S 0.33-16	S301	87-A91-024-080		SW,TACT KSH0611BT
C352	87-010-384-080		CAP, ELECT 100-25V	S302	87-A91-024-080		SW,TACT KSH0611BT
C353	87-010-400-080		CAP, ELECT 0.47-50V	S303	87-A91-024-080		SW,TACT KSH0611BT
C501	87-010-197-080		CAP, CHIP 0.01 DM	S304	87-A91-024-080		SW,TACT KSH0611BT
C531	87-010-374-080		CAP, ELECT 47-10V	S305	87-A91-024-080		SW,TACT KSH0611BT
C532	87-010-374-080		CAP, ELECT 47-10V	S306	87-A91-024-080		SW,TACT KSH0611BT
C535	87-010-213-080		C-CAP,S 0.015-50 B	S307	87-A91-024-080		SW,TACT KSH0611BT
C536	87-010-213-080		C-CAP,S 0.015-50 B	S308	87-A91-024-080		SW,TACT KSH0611BT
C537	87-010-400-080		CAP, ELECT 0.47-50V	S309	87-A91-024-080		SW,TACT KSH0611BT
C538	87-010-400-080		CAP, ELECT 0.47-50V	S310	87-A91-024-080		SW,TACT KSH0611BT
C539	87-010-400-080		CAP, ELECT 0.47-50V	S311	87-A91-024-080		SW,TACT KSH0611BT
C540	87-010-400-080		CAP, ELECT 0.47-50V				
C541	87-010-401-080		CAP, ELECT 1-50V				
C542	87-010-401-080		CAP, ELECT 1-50V				
C543	87-010-154-080		CAP CHIP 10P				
C583	87-012-283-080		CAP,CHIP 5600P				
C584	87-012-283-080		CAP,CHIP 5600P				
C591	87-010-180-080		C-CER 1500P				
C592	87-010-180-080		C-CER 1500P				
C603	87-010-402-080		CAP, ELECT 2.2-50V	REMO C.B			
C604	87-010-402-080		CAP, ELECT 2.2-50V	C341	87-010-405-080		CAP, ELECT 10-50V
C605	87-010-408-080		CAP, ELECT 47-50V	CN302	87-A60-827-010		CONN,6P B TMC-D(P)
C607	87-010-405-080		CAP, ELECT 10-50V	S321	87-A91-024-080		SW,TACT KSH0611BT
C608	87-010-405-080		CAP, ELECT 10-50V				
C609	87-010-196-080		CHIP CAPACITOR,0.1-25				
C610	87-010-384-080		CAP, ELECT 100-25V	MOTOR C.B			
C611	87-010-197-080		CAP, CHIP 0.01 DM				

BLOCK DIAGRAM-1 (CD)

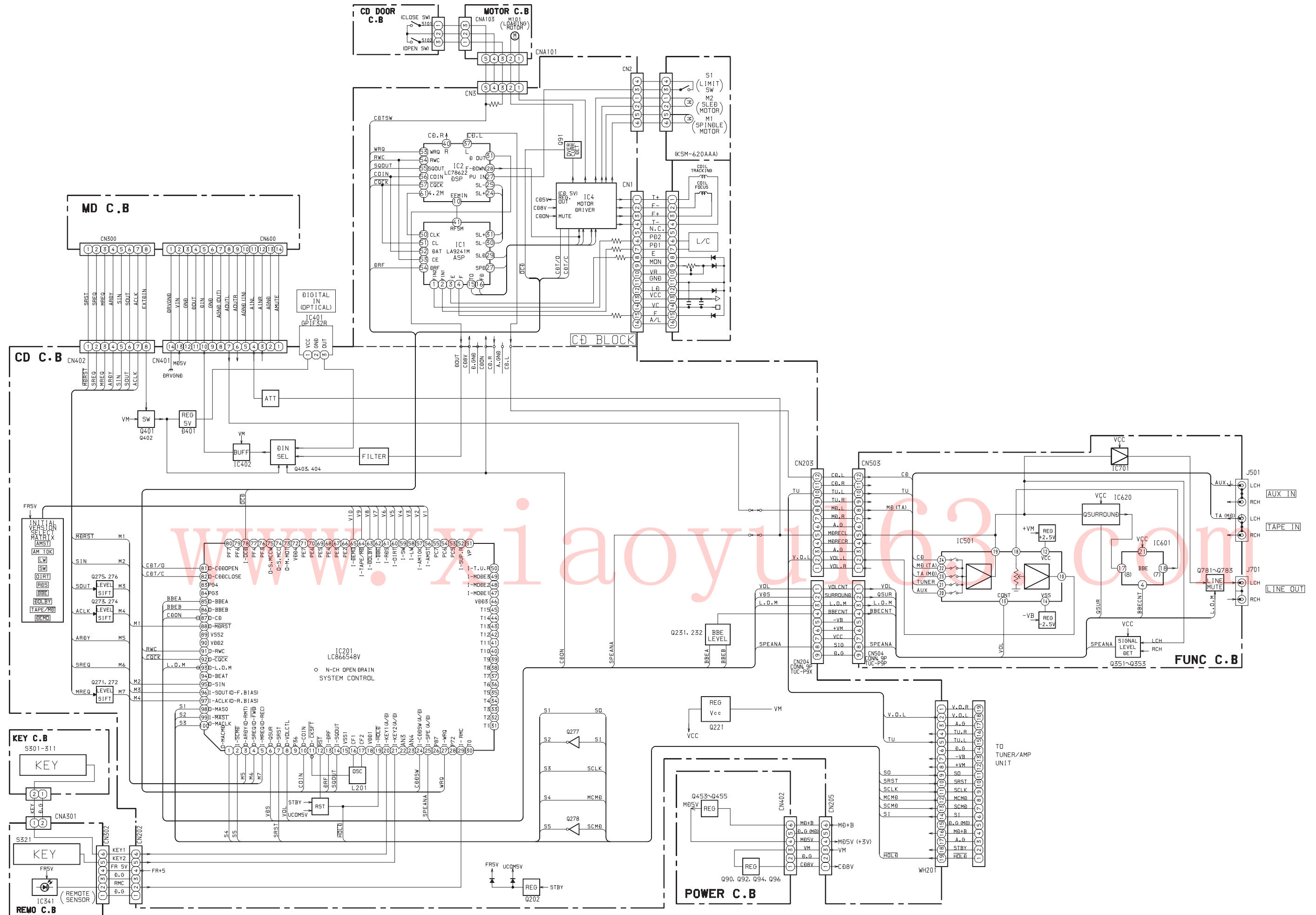

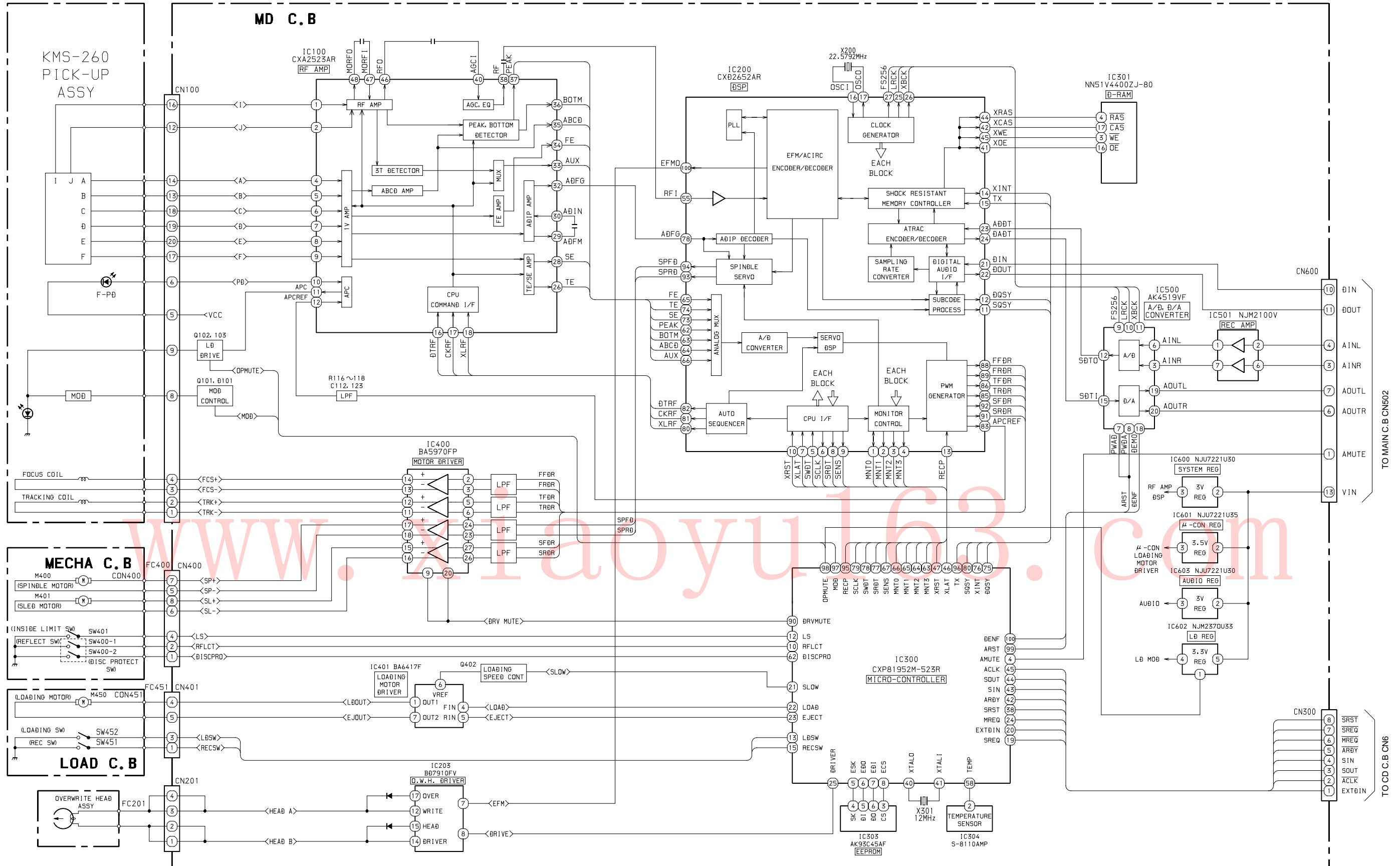

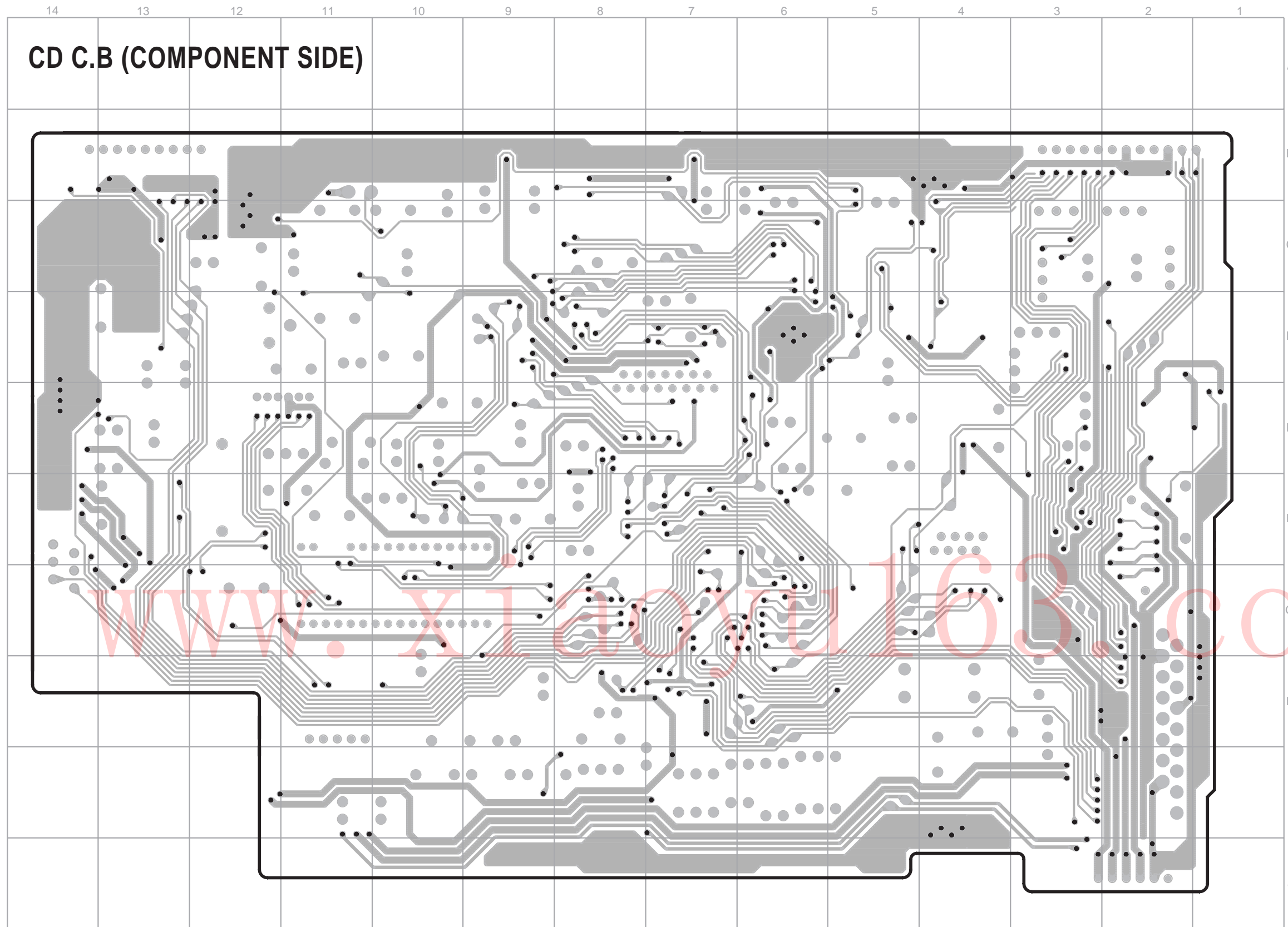

1 2 3 4 5 6 7 8 9 10 11 12 13 14

CD C.B (CONDUCTOR SIDE)

TO FUNC C.B
CN503

PICK UP
TO ASSY

TO FUNC C.B
CN504

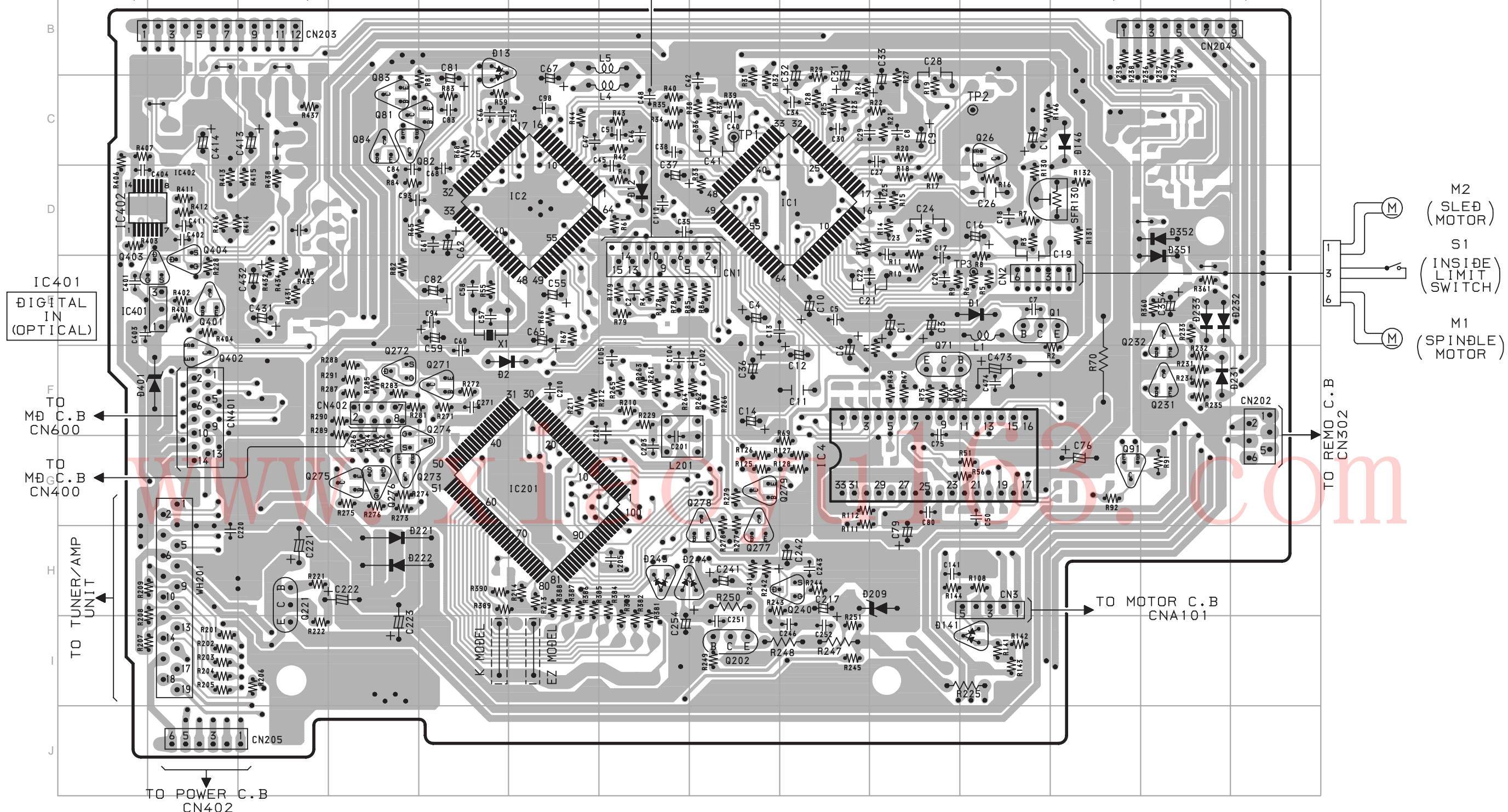

IC401
DIGITAL IN
(OPTICAL)

TO MB C.B
CN600

TO MB C.B
CN400

TO TUNER/AMP
UNIT

TO POWER C.B
CN402

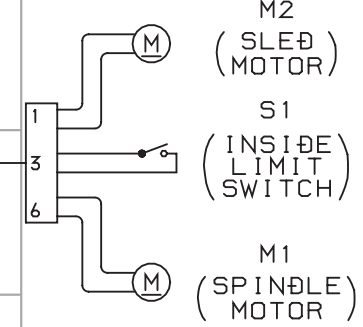

TO REMO C.B
CN302

TO MOTOR C.B
CNA101

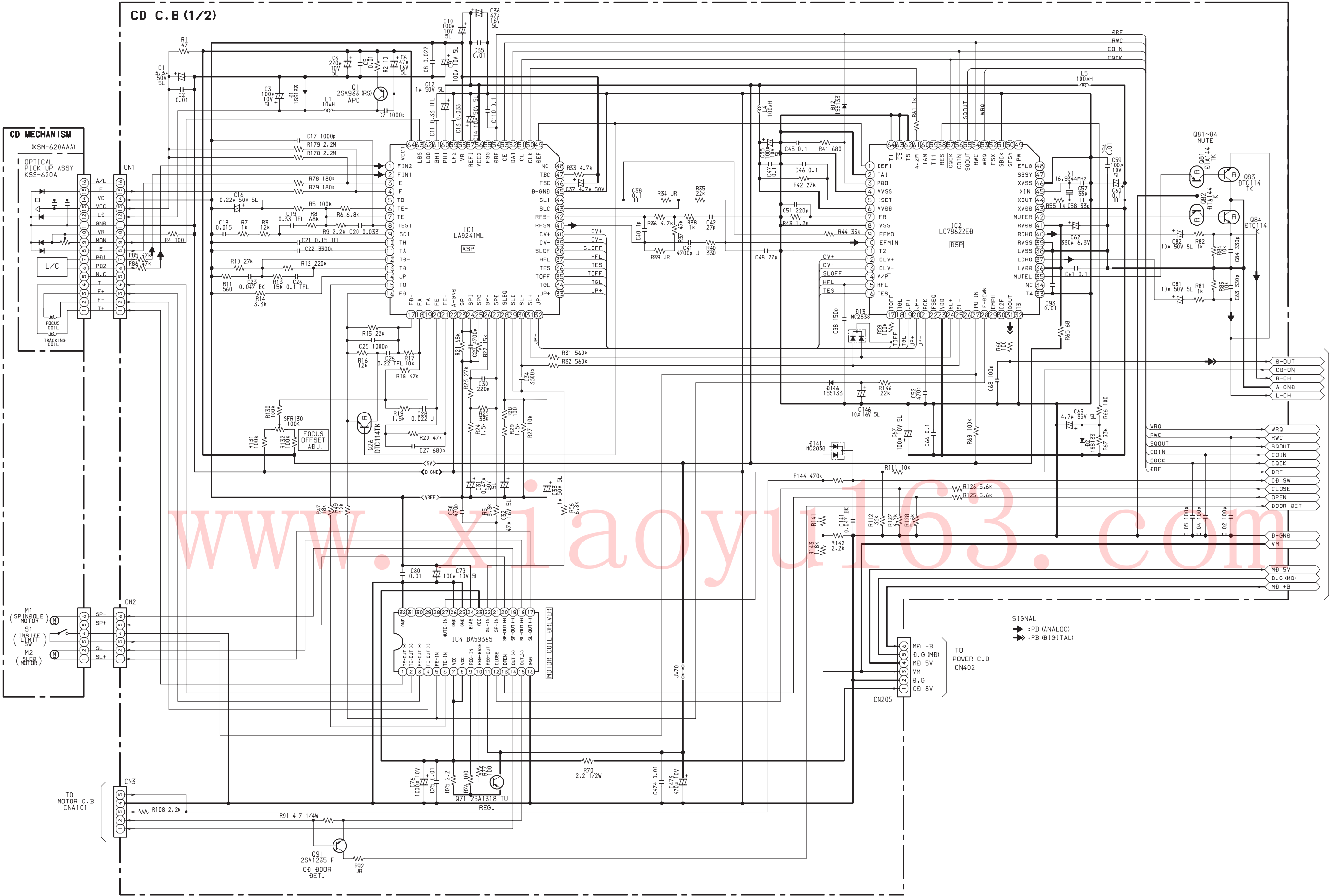

SCHEMATIC DIAGRAM-2 (CD 2/2)

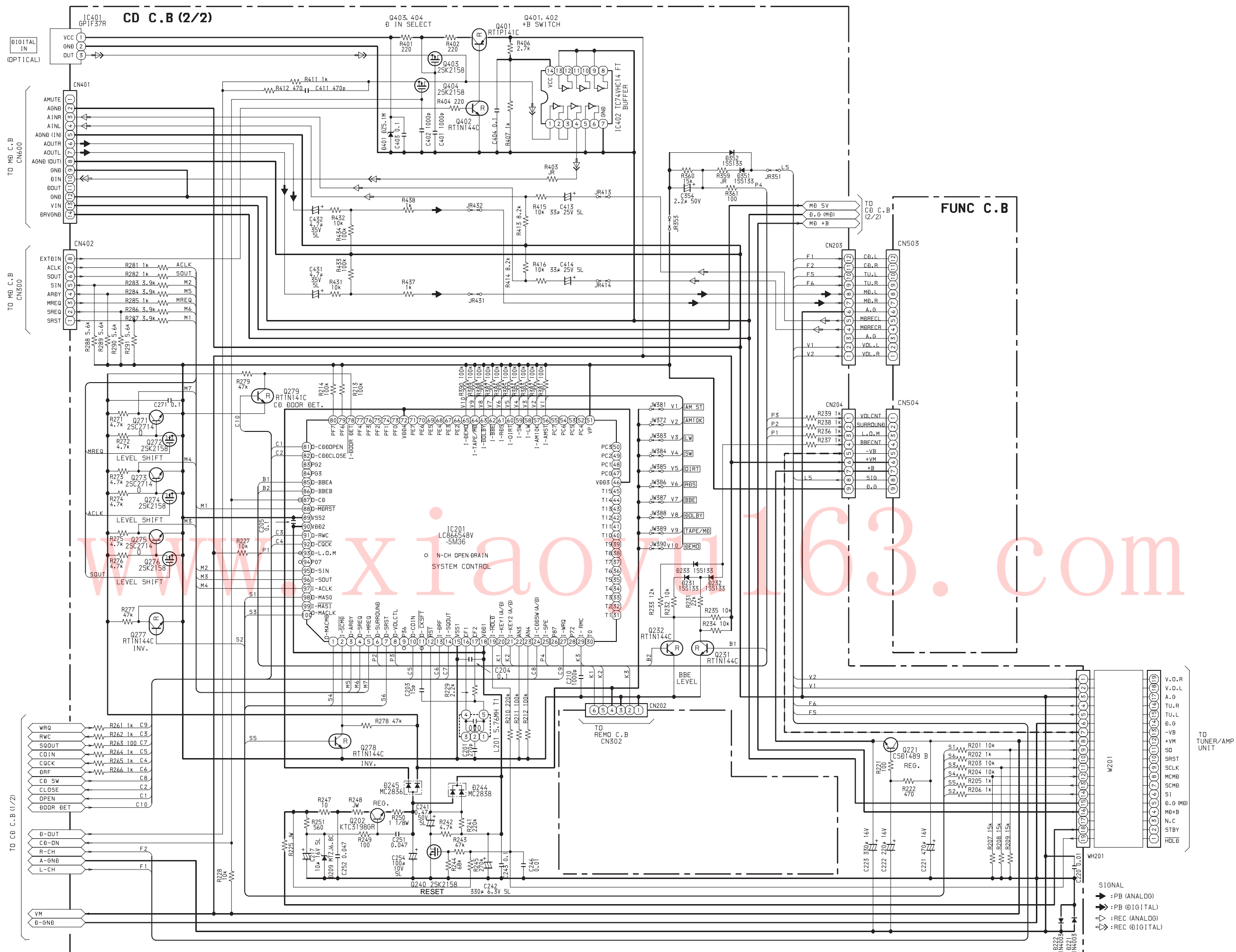

WIRING-2 (FUNCTION)

1 2 3 4 5 6 7 8 9 10 11 12 13 14

A
B
C
D
E
F
G
H
I
J
K

KEY C.B

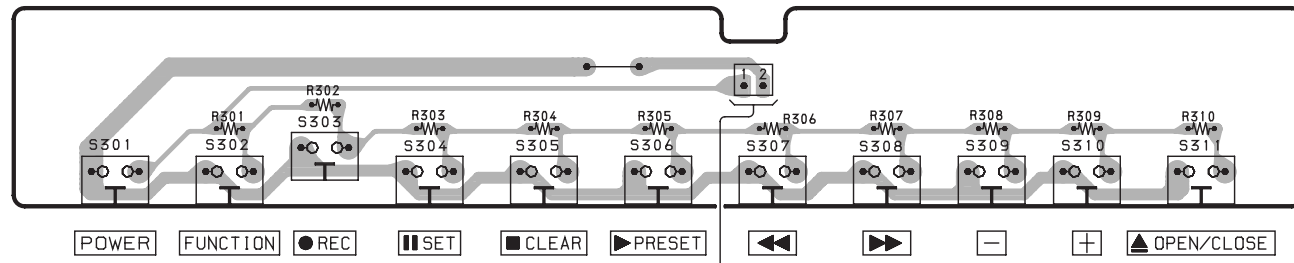

CD DOOR C.B

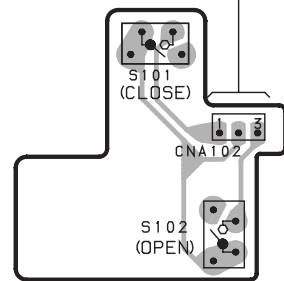

REMO C.B

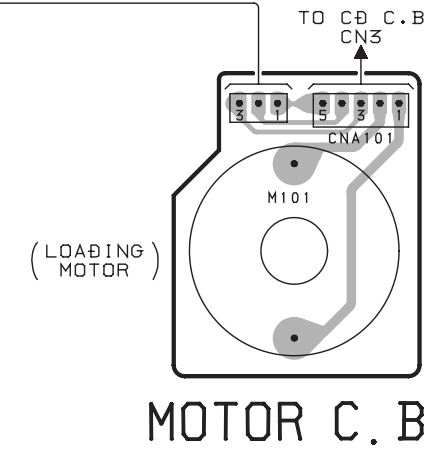
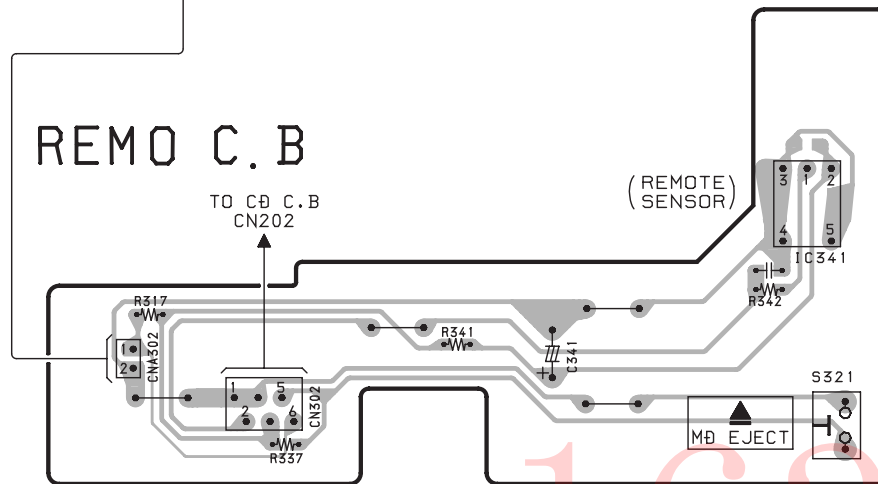

POWER C.B

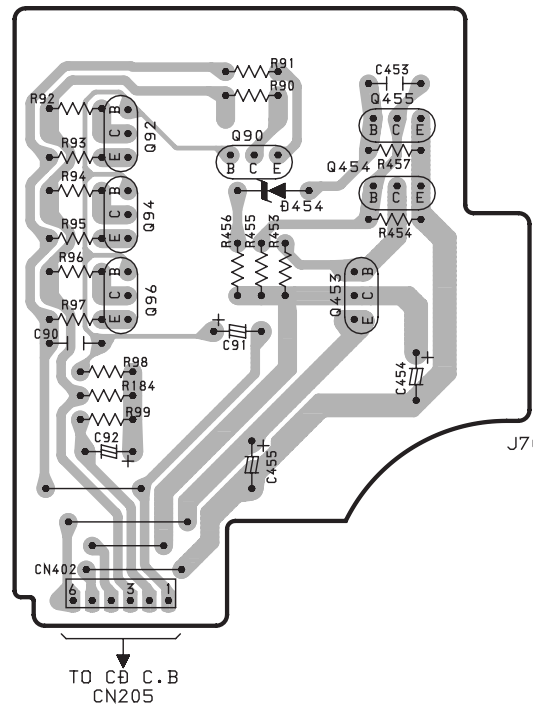

FUNC C.B

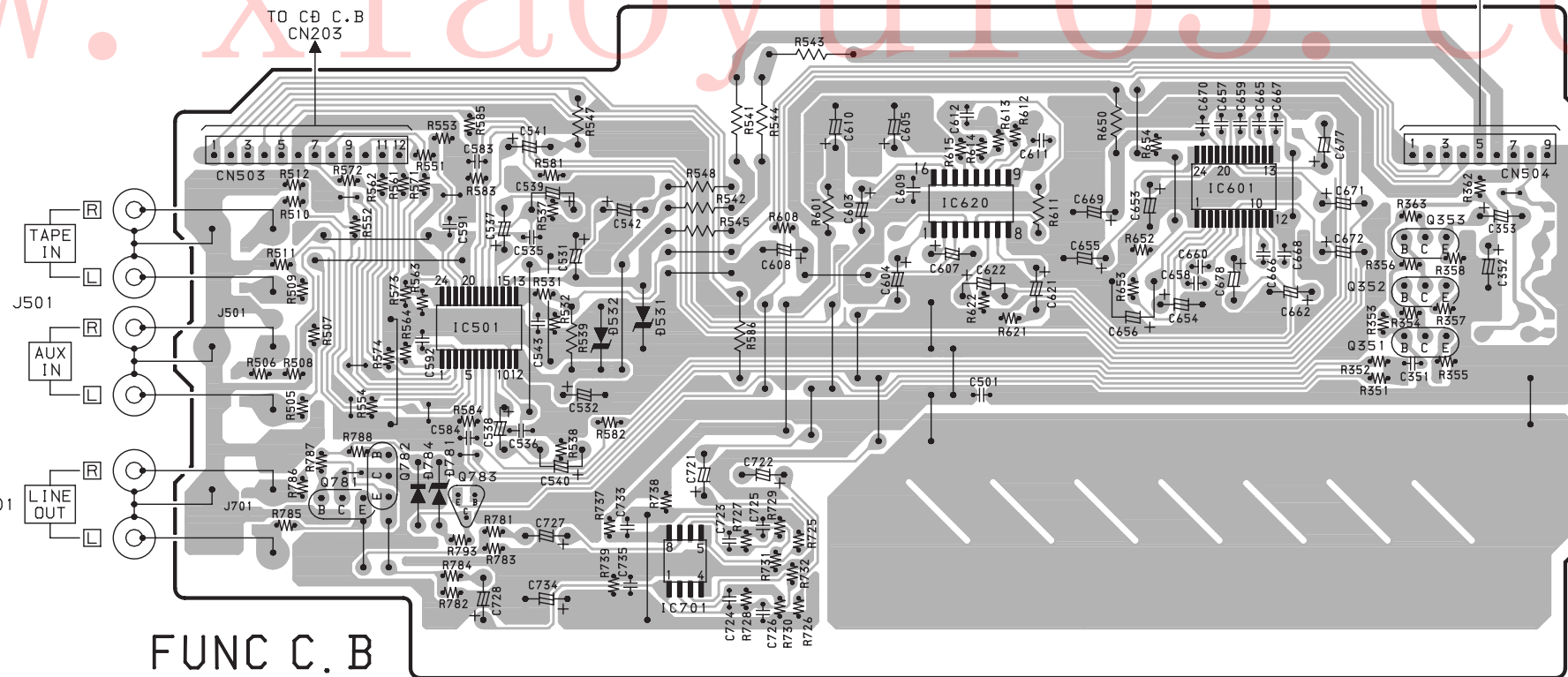

www.xiaoyu163.com

SCHEMATIC DIAGRAM-3 (FUNCTION)

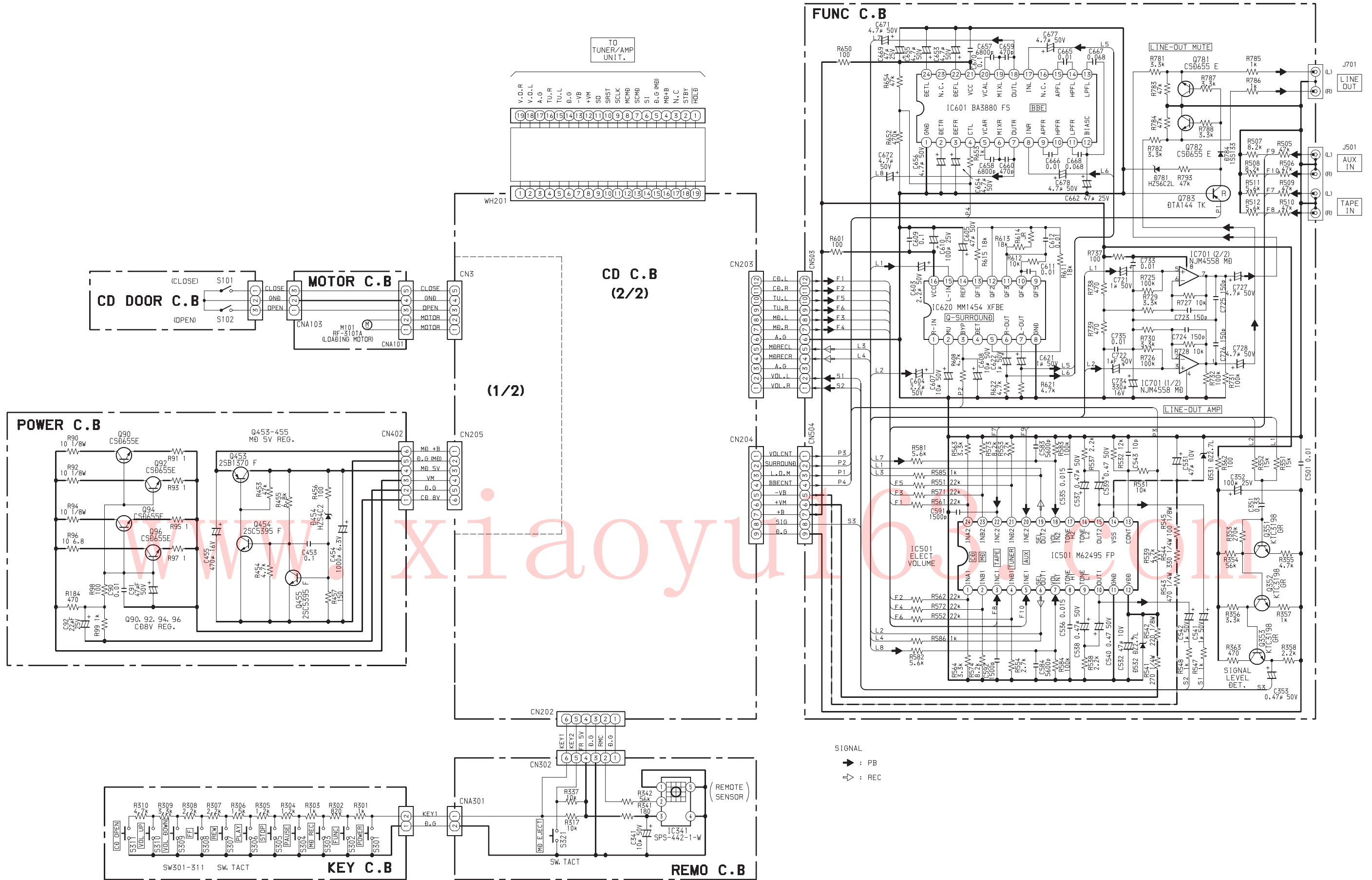

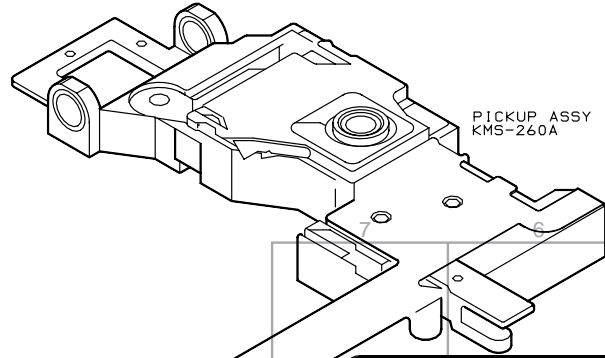

MĐ C. B (COMPONENT SIDE)

MĐ C. B (CONDUCTOR SIDE)

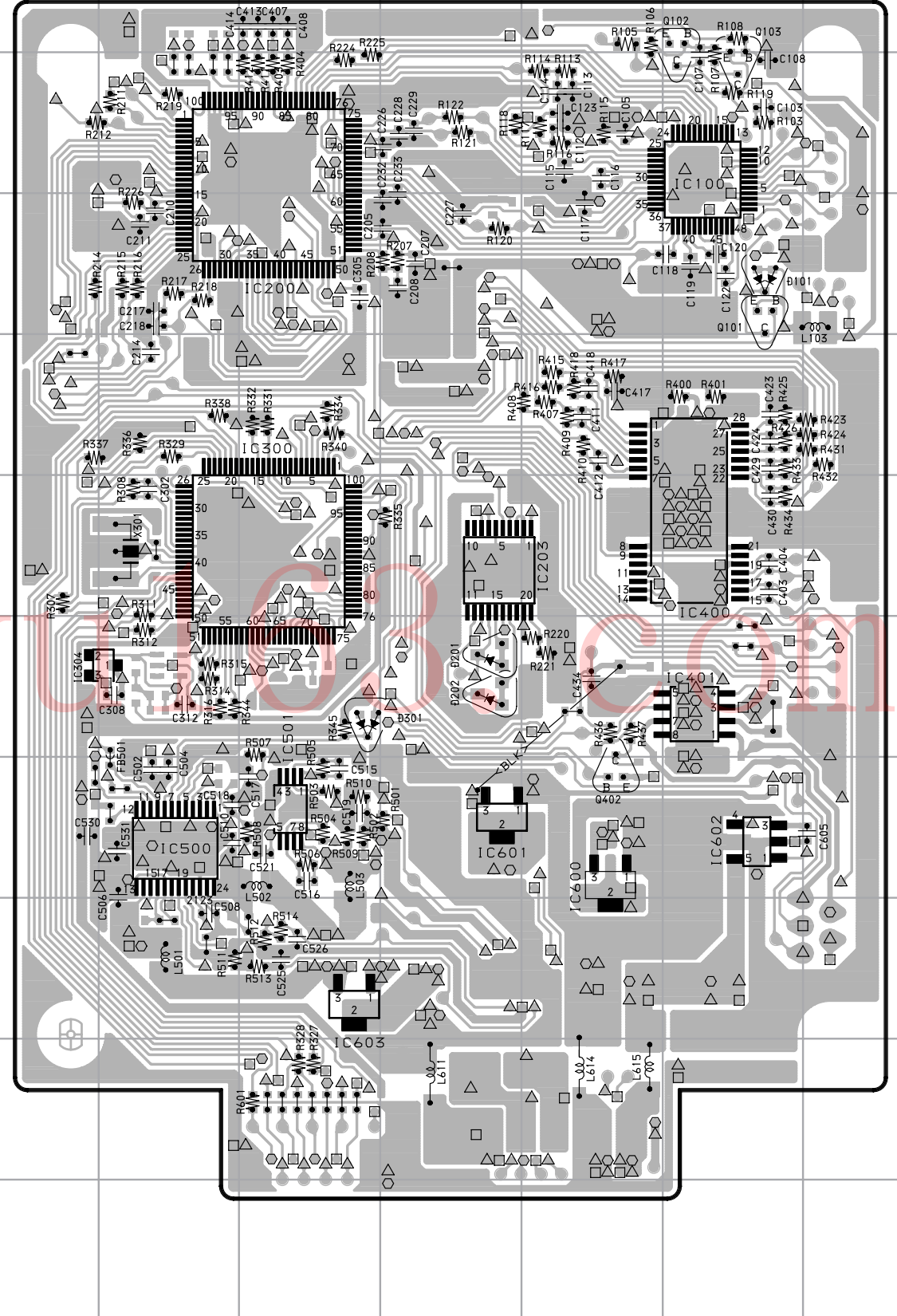
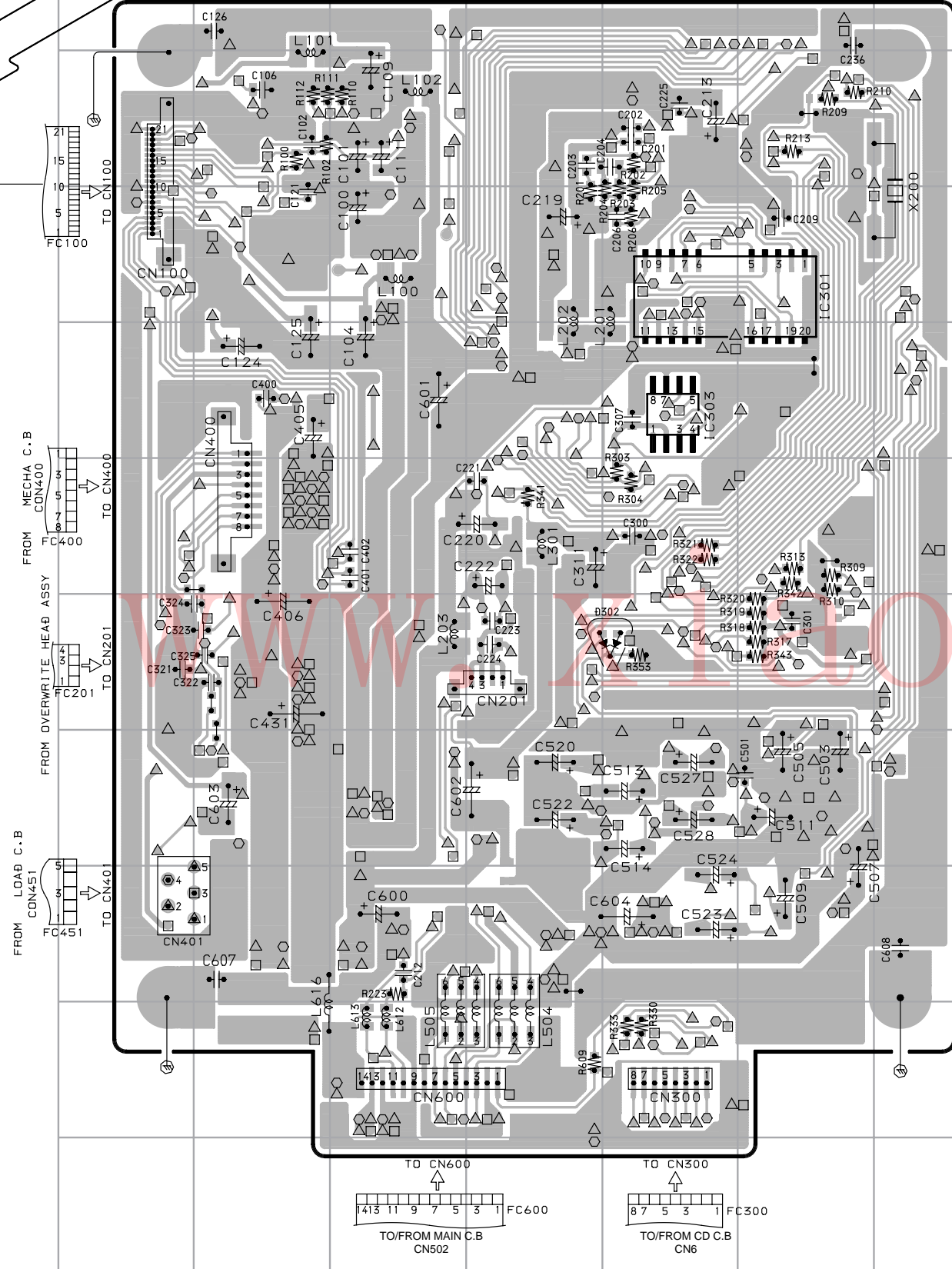

SCHEMATIC DIAGRAM-4 (MD)

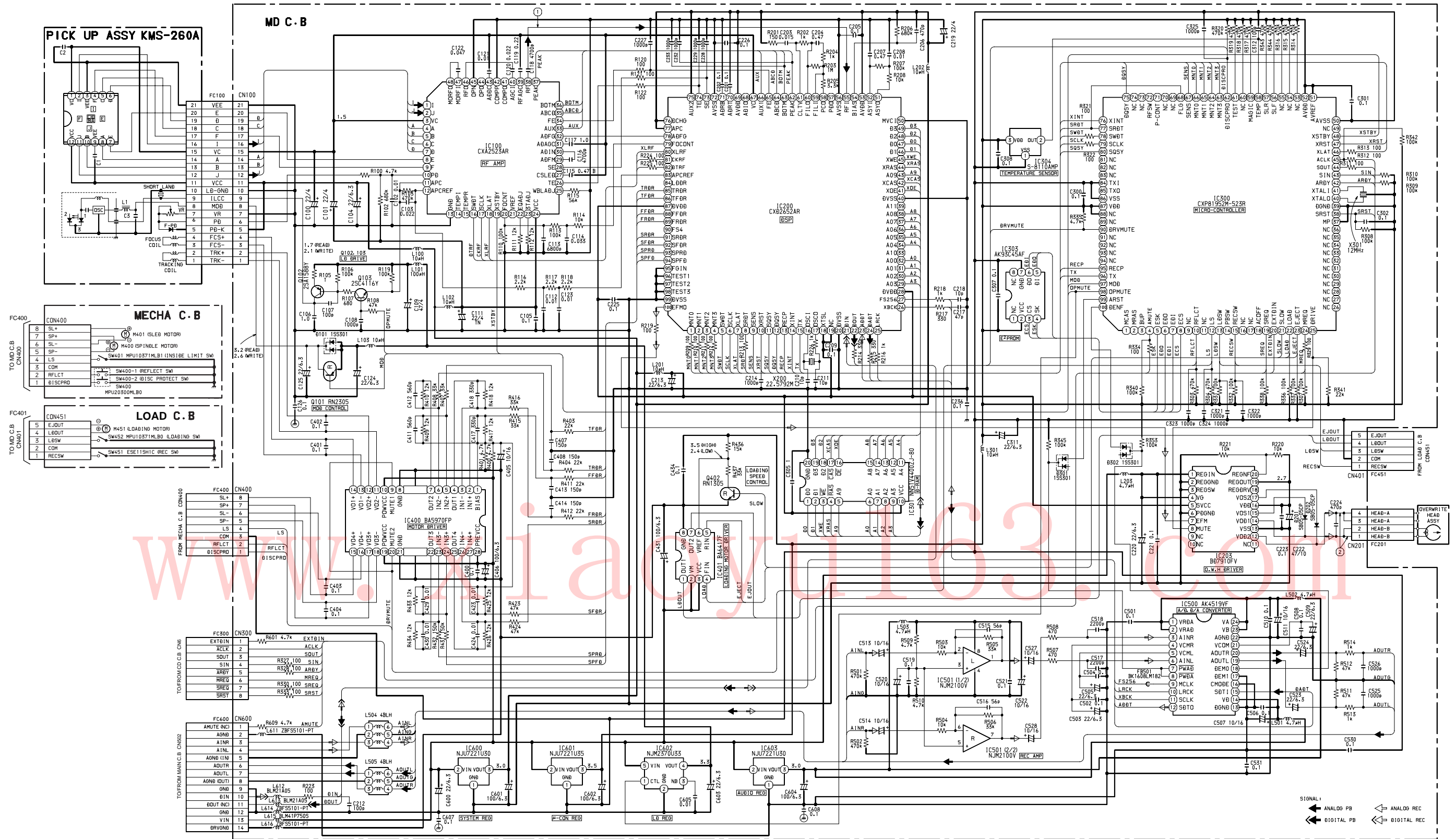

WIRING-4 (MECHANISM)

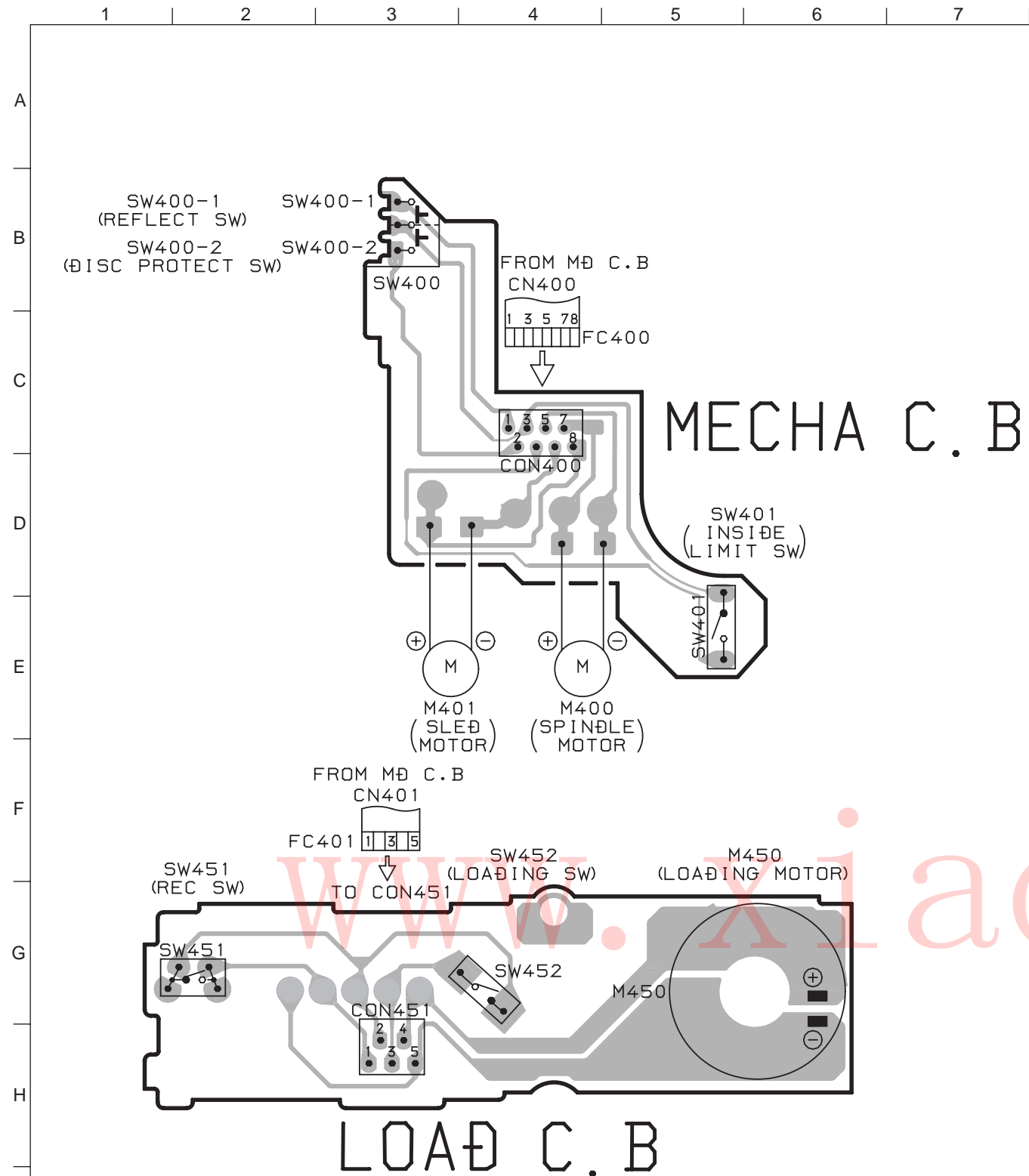

TEST MODE

1. CD Test Mode

1-1. How to Start Up the CD Test Mode

While pressing the "CD OPEN/CLOSE" button, connect the AC plug to the power outlet. When the CD test mode is started up, When the CD test mode starts up, all displays turn on.

Note: When the PANEL, TOP has been removed for each CHAS, GEAR, be sure to short pin-4 and pin-5 of the connector CN3 on the CD board in order to recognize that the CD lid is closed.

1-2. Releasing the CD Test Mode

Remove the shorting between pin-4 and pin-5 of the connector CN3 on the CD board to return to the original setup. Then press the POWER button or the FUNCTION button, or remove the AC plug from the power outlet to release the CD test mode.

1-3. Function Description of the Test Mode

MODE	Operation	Indication on display	Function	Contents
Start mode	Starting up the test mode	CD TEST		
Search mode	■	CD	Continuous focus searching. The pickup lens repeats the full-swing up-down motion * Note	Check APC circuit. Laser current measurement. Focus error waveform check.
Play mode	▶	Track No. and playing time are displayed	Normal playback. When the TOC reading is not possible, the same movement as in the search mode.	Focus servo. Tracking servo. CLV servo. Sled servo.
Traverse mode		Track No. and playing time flash	Playback PAUSE mode	Tracking servo OFF.
Sled mode	▶▶ ◀◀	CD TEST	The pickup moves to the innermost track The pickup moves to the outermost track	Sled servo. Check operation of the mechanism.

Note: If the focus search operation is continued for 10 minutes or longer, heating of the driver IC is accumulated to trigger the protection circuit that will stop operation of the CD system. Turn off the main power and re-start operation about 10 minutes later.

2. MD Test Mode

Note: Remote control unit is used to activate most of the MD TEST mode operations in the XR-MD200. (Only the two buttons are located in the XR-MD200 that cannot be found in the remote control unit. These two buttons are the "MD EJECT" button that is used to initiate the MD test mode and the ● button that is used to enter "REC Analog (digital)". Therefore, the MD test mode is described as follows on the premise of using a remote control unit.

2-1. How to Start Up the MD Test Mode

While pressing the "MD EJECT" button, connect the AC plug to the power outlet. About three seconds later after the MD test mode has started up, the following message appears and the MD test mode becomes operable.

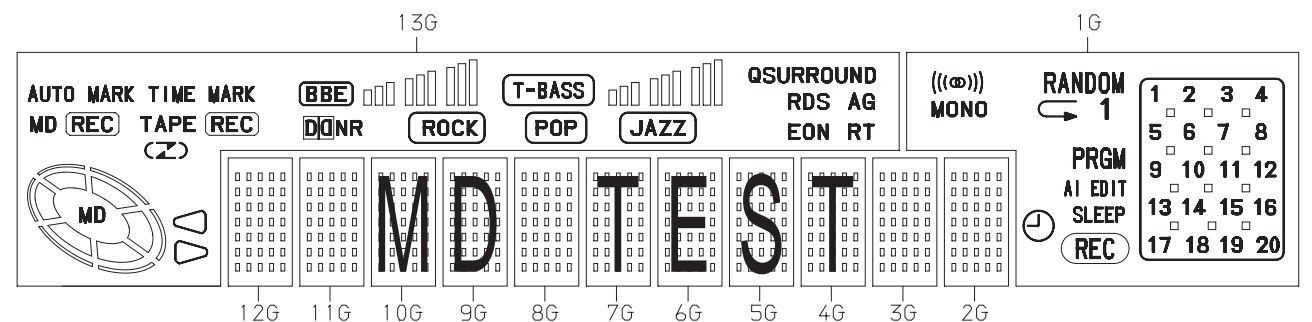

- Note:**
1. If operation of the mechanism shows any abnormality during the test mode, disconnect the AC plug immediately.
 2. The playback and recording operations are not possible during the test mode.
 3. There can be a case that a disc cannot be inserted. In such a case, insert the disc a little and press the “CD → MD DIRECT REC” button. The disc can be inserted to the very end.
 4. “REC Analog” is switched to “REC Digital” by pressing the following buttons in order: ■ button → || button → ● button (main unit).

2-2. How to Exit the CD Test Mode

- 1) Press the “MD EJECT” button to remove the disc.
 - 2) Disconnect the AC plug from the power outlet.
- * If the machine exits the MD test mode by any methods other than the procedure as described above, the machine may operate abnormally when the POWER is turned on next time.
In such a case, disconnect the AC plug.

2-3. Operation Check Mode

- 1) Checks after the test mode has started up
The following playback audio circuits can be checked.
 - The circuits that can be checked: DAC, LINE AMP, HEADPHONES AMP
 - Output level: 1 kHz, -23 dB
- 2) Switch status check
ON/OFF statuses of the respective switches of the machine and mechanism can be checked on display.

Switch Name	Switch State	Indication on Display	Usable disc
REC PROTECT	When the write-protection tab of a disc is closed to ON	ROCK	Record/playback disc
REFLECT	When the high reflection disc (CD) is used	POP	Playback only disc
INNER	When the pickup is the positioned at the innermost track (when the LIMIT switch is ON)	JAZZ	—

2-4. How to Switch to Servo Standby Mode

When the MD test mode has been established, the mode is changed to the servo standby mode and “ALL SV OFF” is displayed by pressing the ■ (CLEAR) button. The following various check modes can be entered from this mode. Returns to “ALL SV OFF” by pressing the ■ button.

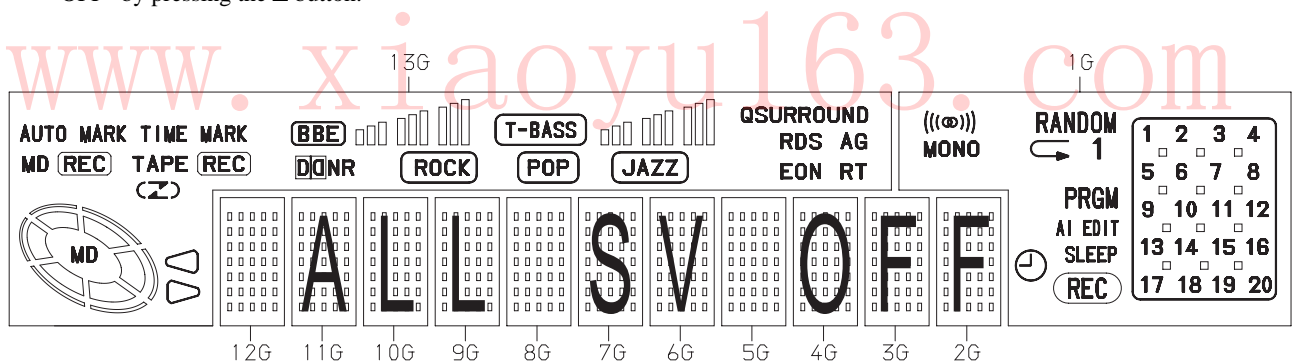

2-5. Checking the Sled Operation

- 1) Pickup moves to the outmost track by pressing the ►► (F.SKIP) in the “ALL SV OFF” state. The message “T.SLED FWD” is displayed.
- 2) Pickup moves to the innermost track by pressing the ◀◀ (B.SKIP) in the “ALL SV OFF” state. The message “T.SLED FWD” is displayed.

2-6. Checking the Laser Output

- 1) The laser power output level can be switched by every pressing of the “EDIT” (SHIFT+9) in the “ALL SV OFF state”. The laser power output is repeatedly changed in the following order of: OFF → LASER READ → LASER 1/2 → LASER WRITE → OFF. The displays are shown as described by the following table.

MODE	Indication on display
OFF	ALL SV OFF
LASER READ	LASER READ
LASER 1/2 WRITE	LASER 1/2
LASER WRITE	LASER WRITE

- 2) After confirming the message, press the ■ button to turn off the “ALL SV OFF” display.

2-7. Checking Operation of OWH (Over Write Head)

The OWH can be moved up and down by pressing the “CD → MD DIRECT REC” and the “EJECT” buttons in the state of loading-completed.

“CD → MD DIRECT REC” button OWH DOWN
 “EJECT” button OWH UP

Note: Do not move down the OWH down when the high reflection disc (CD) is in use.

2-8. Checking the Servo Operation

- Checking the focus search spindle kick
 - 1) The focus search operation and the spindle kick operation can be performed continually by pressing ◀▶ (PLAY) button from the “ALL SV OFF” state without inserting a disc. During this check, the message “FOCUS SRCH” is displayed.
 - 2) After checking these operations, press the ■ button to return to the “ALL SV OFF” state.

- Checking the focus servo

- 1) Insert the test DISC.
- 2) Move the optical pickup to the center track or its around of a disc using the ▶▶ and the ◀◀ buttons.
- 3) Press the “MODE” button until the following servo mode is selected in accordance with the inserted DISC.
 - * MO DISC (MO) Select the “SELECT GRV” indication on the display.
 - * PIT DISC (CD) Select the “SELECT PIT” indication on the display.
- 4) Press the ▶ button.

When the focus servo is operating normally, the message “FOCUS ON!” is displayed after “FOCUS SRCH”.

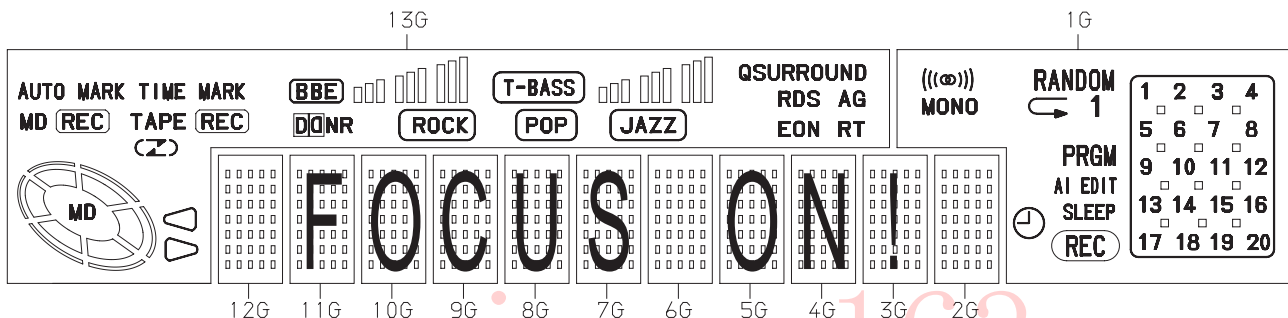

- 5) After the checking is completed, press the ■ button to return to the “ALL SV OFF” state.

- Checking that the all servo loops are turned ON

- 1) The tracking servo and the sled servo are turned on and all servo loops work when the “MD MARK” (SHIFT+10) button is pressed in the state of “FOCUS ON!”.

When all servo loops are normal, “ALL SV ON” is displayed.

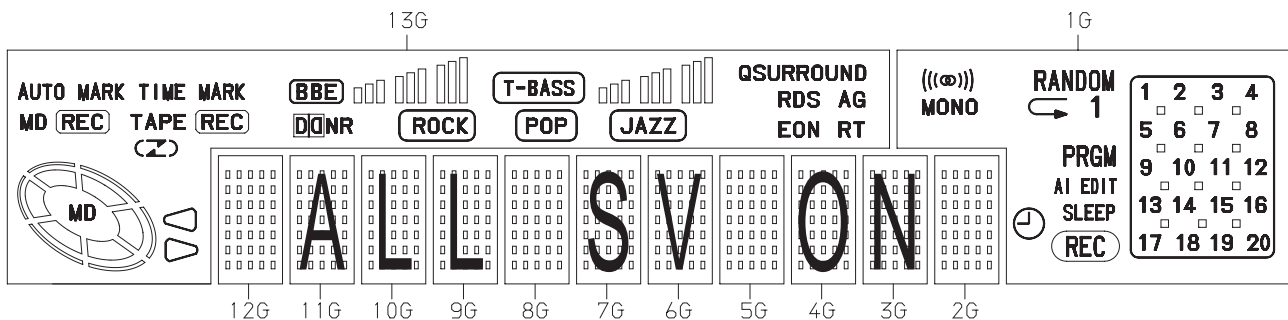

- 2) After the checking is completed, press the ■ button to return to the “ALL SV OFF” state.

2-9. Adjustment Mode

Name of adjustment: Temperature compensation adjustment

Test point: Check the indication on the display.

Jig: Thermometer

Adjustment procedure:

- 1) Start up the MD test mode and press the ■ button to show the message “ALL SV OFF” on display.
- 2) Press the “DISPLAY” (SHIFT+4) button to switch the display to “TEMP=\$◇◇”.
- 3) Press the || (PAUSE) button to switch the display to “TEMP + **: +00”.
- 4) Place the thermometer near the MD mechanism to measure the room temperature.
- 5) Adjust the indication value on display until the room temperature is the same as the indicated temperature ** on the display using the ►► and ◄◄ buttons. After adjustment is complete, press the “MD MARK” (SHIFT+10) button.
- 6) After the adjustment is completed, press the ■ button to return to the “ALL SV OFF” state.
- 7) After the above settings are completed, reduce or add the value indicated by the sharp sign (##) of “TEMP + **: +00” from or to the value indicated by the asterisk (**) of “TEMP + **: +00”. The calculated value must be the room temperature.

Note: If the room temperature cannot be measured, do not adjust the above item.

3. Laser Power Adjustment

Test point: Pickup laser output

Jig: Laser power meter

Adjusting procedure:

- 1) Press the “EDIT” (SHIFT+8) button three times in the state of “ALL SV OFF” in order to switch the display to “LASER WRITE”.
- 2) Press the || button once to show the “LASER = \$**”.
- 3) Measure the laser output of the pickup unit using a laser power meter. Adjust the laser output value for 6.8 ± 0.03 mW by pressing the ►► and ◄◄ buttons. After adjustment, press the “MD MARK” (SHIFT+10) button.
- 4) After the adjustment is completed, press the ■ button to return to the “ALL SV OFF” state.

Note: If the laser output exceeds 7.0 mW, the pickup may be damaged.

4. Auto Sequence Adjustment (EFB Adjustment, IVR Adjustment, Focus AGC Adjustment and Tracking AGC Adjustment)

Test disc: MDW-60, TGYS-1

When using the MO disc for adjustment:

- 1) Insert the test disc MDW-60.
- 2) Press the ■ button to show “ALL SV OFF” on display.
- 3) Press the “MODE” button to show “SELECT GRV” on display.
- 4) When the “MD” button is pressed, “AUTO ADJ” is displayed. When the adjustment is completed, “DONE” is displayed. (If “FAILED” is displayed, it shows that the adjustment has failed and is not performed.)
- 5) After the adjustment is completed, press the ■ button to return to the “ALL SV OFF” state.

Note: 1. Be sure to use the clean disc because the adjustment cannot be ensured if the dirty disc or the scratches on a disc is used.
2. Be sure to use an MO disc that is permitted to record a new data because the MO disc is tested by writing power and a part of the recorded data is erased.

How to check the IVR, EFB, Focus/Tracking/Sled Gains

- ① Move the optical pickup to the center track or its around of a disc using the ►► and the ◄◄ buttons.
- ② Press the ► button to show “FOCUS ON!” on display.
- ③ Press the “ENTER” button to switch the mode to “ALL SV ON”.
- ④ Press the ■ button and press twice the “DISPLAY” button.
Check that the indication value on the display “IV\$*:EF\$◇◇” is within the range as follows below.
“**” 03-07
“◇◇” 09-12
- ⑤ Press the “DISPLAY” (SHIFT+4) button again.
Check that the indication value on the display “Gf*t##s△△” is within the following ranges.
“**” 20 to 40
“##” 15 to 35
“△△” 15 to 35
- ⑥ After the checking is completed, press the ■ button to return to the “ALL SV OFF” state.

When using the PIT disc for adjustment:

- 1) Insert the test disc TGYS-1.
- 2) Press the ■ button to show “ALL SV OFF” on display.
- 3) When the “MD function” button is pressed, “AUTO ADJ” is shown on display. When adjustment is completed, “DONE” is displayed. (If “FAILED” is displayed, it shows that the adjustment has failed and is not performed.)
- 4) After the adjustment is completed, press the ■ button to return to the “ALL SV OFF” state.

Checking Method of IVR, EFB, Focus/Tracking/Sled Gain

Perform the same operation as that of the “When using the MO disc for adjustment” and confirm that the values on the display are within the following ranges.

- “IVR” 13 to 17
- “EFB” 09 to 12
- “Focus gain” 2A to 45
- “Tracking gain” 20 to 40
- “Sled gain” 20 to 40

5. Checking Focus Servo and Error Rate (PIT Disc)

- 1) Insert the test disc TGYS-1.
- 2) Move the optical pickup to the center track or its around of a disc using the ►► and the ◀◀ buttons.
- 3) Press the “MODE” button to show “SELECT PIT” on the display.
- 4) Press the ► button to show “FOCUS ON!” on the display..
- 5) Press the “MD MARK” (SHIFT+10) button to show “ALL SV ON” on the display. Then press the “DISPLAY” (SHIFT+4) button once to check that the address display advances with regularity.
- 6) Press the “DISPLAY” (SHIFT+4) button again to show the playback error rate on display and check that the value shown by the asterisks (****) of “Er****:000” is “0030” or less.
- 7) After the adjustment is completed, press the ■ button to return to the “ALL SV OFF” state.

6. Checking Record/Playback Error Rate (MO Disc)

- 1) Insert the test disc MDW-60.
- 2) Move the optical pickup to the center track or its around of a disc using the ►► and the ◀◀ buttons.
- 3) Press the “CD function” button to start recording from 600 cluster.
- 4) After about 15 seconds of recording, press the ■ button to show “ALL SV OFF” on display.
- 5) Press the “AUX/D-IN/TAPE” button to show “ADR****c##s”. When the address indication on display shows the record start position, press the “DISPLAY” button (SHIFT+4) to show “Er◇◇◇◇:◆◆◆◆”. Confirm that the value of ◇◇◇◇ is 0020 or less under this setup.
- 6) After adjustment, press the ■ button to show “ALL SV OFF” on display.

SERVICE JIG AND TOOLS

Use the following jigs when opening the C.B boards.

	NAME	PART NO
CD	JIG, P-CD BY TORIKOSHI	SV-J00-018-010
	FF-CABLE, 16P 1.0 250mm	87-CE1-640-010
MD	FFC, 8P-1.0P	SV-J00-043-010
	FFC, 14P-1.0P	SV-J00-044-010

ELECTRICAL ADJUSTMENT

CD C.B

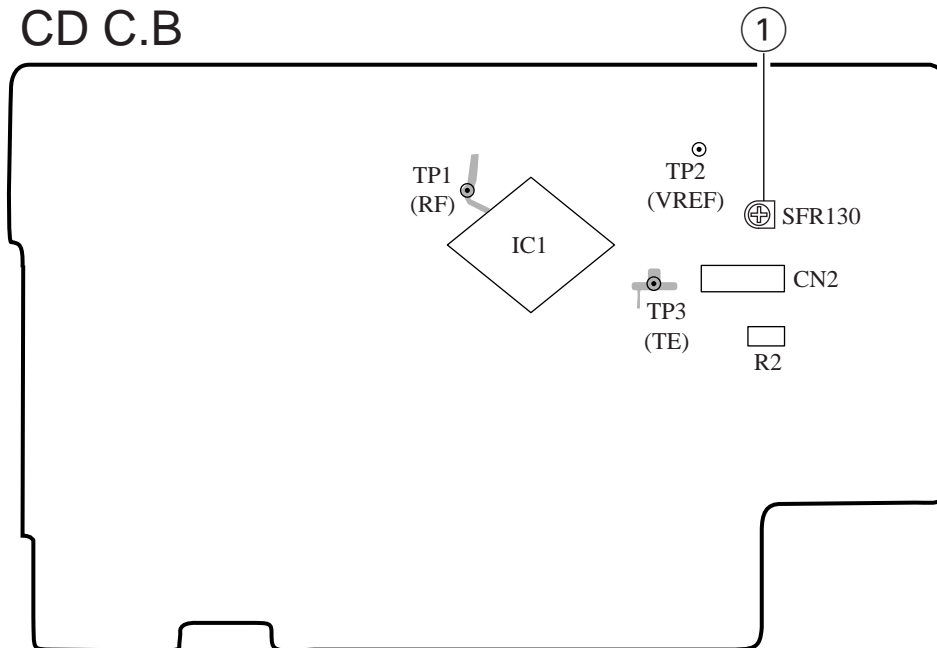

- Note:**
- Connect a probe (10: 1) of the oscilloscope test point for adjustment.
 - Connect ground (⊖) terminal of oscilloscope probe to TP3 (VREF) for all adjustment.

1. Focus Bias Adjustment

Make the focus bias adjustment when replacing and repairing the optical block.

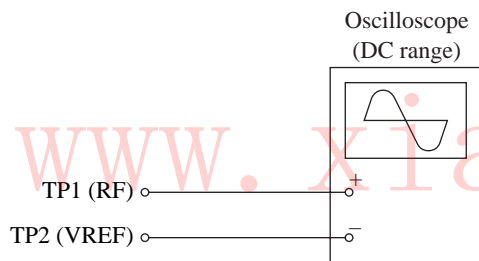

- 1) Connect an oscilloscope to test points TP1 (RF) and TP2 (VREF).
- 2) Turn on the power switch.
- 3) Insert test disc TCD-782 (YEDS-18) and play back the second program.
- 4) Adjust SFR103 so that RF signal of the test point TP1 (RF) is MAX and CLEARREST.

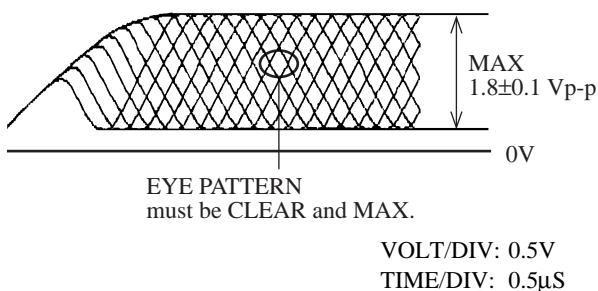

2. Tracking Balance Check

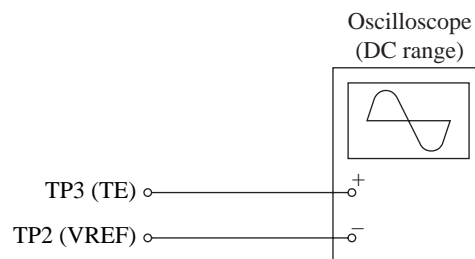

- 1) Connect an oscilloscope to test points TP3 (TE) and TP2 (VREF).
- 2) Start up the CD test mode.
- 3) Insert the test disc TCD-782 (YEDS-18) and enter the traverse mode of the CD test mode.
- 4) Confirm that the traverse waveform on an oscilloscope is vertically symmetrical as shown in the figure below.
- 5) After confirming the waveform, release the CD test mode.

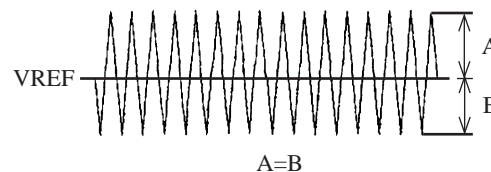

VOLT/DIV: 20mV
TIME/DIV: 1mS

3. Laser Current Check

The current of the laser signal can be checked with the voltages on both sides of R2 (voltage across 10Ω). The difference for the specified value shown on the label must be within ± 6.0mA.

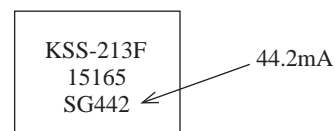

$$\text{Laser current } I_{op} = \frac{\text{Voltage across R2}}{10\Omega}$$

IC DESCRIPTION
IC, LC866548V-5M36

Pin No.	Pin Name	I/O	Description
1	O-MACMD	O	Command output to slave microprocessor.
2	I-SCMD	I	Command input from slave microprocessor.
3	O-ARDY	O	Serial data send/receive preparation completion output for MD UNIT control. (TAPE REC MUTE output).
4	O-SREQ	O	Serial data transfer request for MD UNIT control. (FWD/RWD switching output during TAPE PLAY/REC).
5	I-MREQ	I	Serial data transfer request for MD UNIT control. (REC/PB switching output).
6	O-SURROUND	O	QSURROUND ON/OFF output.
7	O-SRST	O	Reset signal output to slave microprocessor.
8	O-VOLCTL	O	Connected to VOL/P.EQ IC M62439SP pin-⑪ CONT.
9	P36	O	NC.
10	O-COIN	O	Connected to CD DSP LC78622E pin-56 COIN and CD ASP LA9240M pin-52 DAT.
11	O-CKSFT	O	Clock shift output. "L" at clock shift.
12	RST	I	Microprocessor reset.
13	I-DRF	I	Connected to CD ASP LA9240M pin-54 DRF.
14	I-SQOUT	I	Connected to CD DSP LC78622E pin-55 SQOUT.
15	VSS1	—	GND.
16	CF1	I	5.76 MHz. Connected to oscillator.
17	CF2	O	
18	VDD1	—	Microprocessor power supply. (μ -com 5V).
19	I-HOLD	I	Hold state detection. (A/D).
20, 21	I-KEY1, I-KEY2	I	KEY AD data input.
22	AN3	I	DECA MECA state detection input. (AD).
23	AN4	I	TAPE MUSIC SENSOR input. (A/D).
24	I-CDDSW	I	CD DOOR OPEN/CLOSE state detection input. (AD).
25	I-SPE	I	Spare level detection. (A/D).
26	P87	I	NC.
27	I-WRQ	I	Connected to CD DSP LC78622E pin-53 WRQ.
28	P72	I	NC.
29	I-RMC	I	Remote control signal input.
30-45	T0-T15	—	NC.
46	VDD3	—	Microprocessor power supply. (μ -com 5V).
47-49	PC0-PC2	I	DECK MECA state detection input.
50	PC3	I	Rotation detection of TAKE UP REEL of DECK MECA.
51	VP	—	Connected to negative polarity power supply -VFL for FL.
52	PC4	I	Rotation detection of TAKE UP REEL of DECK MECA.
53-55	PC5-PC7	I	NC.
56	I-AMST	I	INITIAL DIODE MATRIX input.
57	I-AM10K	I	
58	I-LW	I	
59	I-SW	I	

Pin No.	Pin Name	I/O	Description
60	I-OIRT	I	INITIAL DIODE MATRIX input.
61	I-RDS	I	
62	I-BBE	I	
63	I-DOLBY	I	
64	I-TAPE/MD	I	
65	I-DEMO	I	
66-71	PE2-PE7	I	NC.
72	VDD4	—	Microprocessor power supply. (μ -com 5V).
73	PF0	O	DECK MECA MAIN MOTOR control output.
74, 75	PF1, PF2	O	DECK MECA SUB control output.
76, 77	PF3, PF4	—	NC.
78	I-DOOR DET	I	Over-current detection input to the CD DOOR MOTOR.
79, 80	PF6, PF7	—	NC.
81	O-CDDOPEN	O	CD DOOR OPEN control output.
82	O-CDDCLOSE	O	CD DOOR CLOSE control output.
83, 84	PG2, PG3	—	NC.
85	O-BBEA	O	BBE LEVEL switching output.
86	O-BBEB	O	
87	O-CD	O	Power supply control output of CD block.
88	O-MDRST	O	MD UNIT 7ZG-9A reset signal output.
89	VSS2	—	GND.
90	VDD2	—	Microprocessor power supply. (μ -com 5V).
91	O-RWC	O	Connected to CD DSP LC78622E pin-59 RWC and CD ASP LA9240M pin-53 CF.
92	O-CQCK	O	Connected to CD DSP LC78622E pin-57 CQCK and CD ASP LA9240M pin-51 CL.
93	O-L.O.M	O	LINE OUT MUTE output.
94	P07	—	Not used.
95	O-SIN	O	Serial data output for MD UNIT control.
96	I-SOUT	I	Serial data input for MD UNIT control.(FWD REC BIAS control output).
97	I-ACLK	I	Serial clock input for MD UNIT control. (RWD REC BIAS control output).
98	O-MASO	O	Serial data output to slave microprocessor.
99	I-MASI	I	Serial data input from slave microprocessor.
100	O-MACLK	O	Transfer clock output to slave microprocessor.

IC, LA9241ML

Pin No.	Pin Name	I/O	Description
1	FIN2	I	Pin to which external pickup photo diode is connected. RF signal is created by adding with the FIN1 pin signal. FE signal is created by subtracting from the FIN1 pin signal.
2	FIN1	I	Pin to which external pickup photo diode is connected.
3	E	I	Pin to which external pickup photo diode is connected. TE signal is created by subtracting from the F pin signal.
4	F	I	Pin to which external pickup photo diode is connected.
5	TB	I	DC component of the TE signal is input.
6	TE-	I	Pin to which external resistor setting the TE signal gain is connected between the TE pin.
7	TE	O	TE signal output pin.
8	TESI	I	TES "Track Error Sense" comparator input pin. TE signal is passed through a band-pass filter then input.
9	SCI	I	Shock detection signal input pin.
10	TH	I	Tracking gain time constant setting pin.
11	TA	O	TA amplifier output pin.
12	TD-	I	Pin to which external tracking phase compensation constants are connected between the TD and VR pins.
13	TD	I	Tracking phase compensation setting pin.
14	JP	I	Tracking jump signal (kick pulse) amplitude setting pin.
15	TO	O	Tracking control signal output pin.
16	FD	O	Focusing control signal output pin.
17	FD-	I	Pin to which external focusing phase compensation constants are connected between the FD and FA pins.
18	FA	I	Pin to which external focusing phase compensation constants are connected between the FD- and FA- pins.
19	FA-	I	Pin to which external focusing phase compensation constants are connected between the FA and FE pins.
20	FE	O	FE signal output pin.
21	FE-	I	Pin to which external FE signal gain setting resistor is connected between the FE pin.
22	AGND	—	Analog signal GND.
23	NC	—	No connection.
24	SP	O	Single ended output of the CV+ and CV- pin input signal.
25	SPG	I	Pin to which external spindle gain setting resistor in 12 cm mode is connected.
26	SP-	I	Pin to which external spindle phase compensation constants are connected together with SPD pin.
27	SPD	O	Spindle control signal output pin.
28	SLEQ	I	Pin to which external sled phase compensation constants are connected.
29	SLD	O	Sled control signal output pin.
30, 31	SL-, SL+	I	Sled advance signal input pin from microprocessor.
32, 33	JP-, JP+	I	Tracking jump signal input pin from DSP.
34	TGL	I	Tracking gain control signal input from DSP. Low gain when TGL = H.
35	TOFF	I	Tracking off control signal input pin from DSP. Off when TOFF = H.

Pin No.	Pin Name	I/O	Description
36	TES	O	Pin from which TES signal is output to DSP.
37	HFL	O	“High Frequency Level” is used to judge whether the main beam position is on top of bit or on top of mirror.
38	SLOF	I	Sled servo off control input pin.
39, 40	CV-, CV+	I	CLV error signal input pin from DSP.
41	RFSM	O	RF output pin.
42	RFS-	I	RF gain setting and EFM signal 3T compensation constant setting pin together with RFSM pin.
43	SLC	O	“Slice Level Control” is the output pin which controls the RF signal data slice level by DSP.
44	SLI	I	Input pin which control the data slice level by the DSP.
45	DGND	—	Digital system GND.
46	FSC	O	Output pin to which external focus search smoothing capacitor is connected.
47	TBC	I	“Tracking Balance Control” EF balance variable range setting pin.
48	NC	—	No connection.
49	DEF	O	Disc defect detector output pin.
50	CLK	I	Reference clock input pin. 4.23 MHz of the DSP is input.
51	CL	I	Microprocessor command clock input pin.
52	DAT	I	Microprocessor command data input pin.
53	CE	I	Microprocessor command chip enable input pin.
54	DRF	O	“Detect RF” RF level detector output.
55	FSS	I	“Focus Search Select” focus search mode (\pm search/+ search) select pin.
56	VCC2	—	Servo system and digital system Vcc pin.
57	REFI	—	Pin to which external bypass capacitor for reference voltage is connected.
58	VR	O	Reference voltage output pin.
59	LF2	I	Disc defect detector time constant setting pin.
60	PH1	I	Pin to which external capacitor for RF signal peak holding is connected.
61	BH1	I	Pin to which external capacitor for RF signal bottom holding is connected.
62	LDD	O	APC circuit output pin.
63	LDS	I	APC circuit input pin.
64	VCC1	—	RF system Vcc pin.

IC, LC78622ED

Pin No.	Pin Name	I/O	Description	
1	DEFI	I	Defect sense signal (DEF) input pin. (Connect to 0V when not used).	
2	TAI	I	For PLL.	Test signal input pin with built-in pull-down resistor. Be sure to connect to 0V.
3	PDO	O		Phase comparator output pin to control external VCO.
4	VVSS	—		GND pin for built-in VCO. Be sure to connect to 0V.
5	ISET	I		Pin to which external resistor adjusting the PDO output current.
6	VVDD	—		Power supply pin for built-in VCO.
7	FR	I		Pin for VCO frequency range adjustment.
8	VSS	—	Digital system GND. Be sure to connect to 0V.	
9	EFMO	O	For slice level control.	EFM signal output pin.
10	EFMIN	I		EFM signal input pin.
11	TEST2	I	Test signal input pin with built-in pull-down resistor. Be sure to connect to 0V.	
12, 13	CLV+, CLV-	O	Disc motor control output. Three level output is possible using command.	
14	V/P	O	Rough servo or phase control automatic selection monitoring output pin. Rough servo at H. Phase servo at L.	
15	HFL	I	Track detect signal input pin. Schmidt input.	
16	TES	I	Tracking error signal input pin. Schmidt input.	
17	TOFF	O	Tracking OFF output pin.	
18	TGL	O	Tracking gain selection output pin. Gain boost at L.	
19, 20	JP+, JP-	O	Track jump control signal output pin. Three level output is possible using command.	
21	PCK	O	EFM data playback clock monitoring pin 4.3218 MHz when phase is locked in.	
22	FSEQ	O	Sync signal detection output pin. H when the sync signal which is detected from EFM signal and the sync signal which is internally generated agree.	
23	VDD	—	Digital system power supply pin.	
24-28	SL+ - PUIN	I/O	General purpose input/output pin 1 to 5.	The pin is controlled by the serial data command from microprocessor. When the pin is not used, set the pin to the input terminal and connect to 0V, or alternately set the pin to output terminal and leave the pin open.
29	EMPH	O	De-emphasis monitor output pin. De-emphasis disc is being played back at H.	
30	C2F	O	C2 flag output pin.	
31	DOUT	O	DIGITAL OUT output pin. (EIAJ format).	
32, 33	TEST3, TEST4	I	Test signal input pin with built-in pull-down resistor. Be sure to connect to 0V.	
34	N.C.	—	Not used. Set the pin to open.	
35	MUTEL	O	L-channel 1-bit DAC.	L-channel mute output pin.
36	LVDD	—		L-channel power supply pin.
37	LCHO	O		L-channel output pin.
38	LVSS	—		L-channel GND. Be sure to connect to 0V.
39	RVSS	—	R-channel 1-bit DAC.	R-channel GND. Be sure to connect to 0V.
40	RCHO	O		R-channel output pin.
41	RVDD	—		R-channel power supply pin.
42	MUTER	O		R-channel mute output pin.

Pin No.	Pin Name	I/O	Description
43	XVDD	—	Crystal oscillator power supply pin.
44	XOUT	O	Pin to which external 16.9344 MHz crystal oscillator is connected.
45	XIN	I	
46	XVSS	—	Crystal oscillator GND pin. Be sure to connect to 0V.
47	SBSY	O	Subcode block sync signal output pin.
48	EFLG	O	C1, C2, single and dual correction monitoring pin.
49	PW	O	Subcode P, Q, R, S, T, U and W output pin.
50	SFSY	O	Subcode frame sync signal output pin. Falls down when subcode enters standby.
51	SBCK	I	Subcode read clock input pin. Schmidt input. (Be sure to connected to 0V when not in use.)
52	FSX	O	Pin outputting the 7.35 kHz sync signal which is generated by dividing frequency of crystal oscillator.
53	WRQ	O	Subcode Q output standby output pin.
54	RWC	I	Read/write control input pin. Schmidt input.
55	SQOUT	O	Subcode Q output pin.
56	COIN	I	Command input pin from microprocessor.
57	\overline{CQCK}	I	Command input read clock or subcode read input clock from SQOUT pin
58	\overline{RES}	I	LC78622 reset input pin. Set this pin to L once when the main power is turned on.
59	TST11	O	Test signal output pin. Use this pin as open (normally L output).
60	16M	O	16.9344 MHz output pin.
61	4.2M	O	4.2336 MHz output pin.
62	TEST5	I	Test signal input pin with built-in pull-down resistor. Be sure to connect to 0V.
63	\overline{CS}	I	Chip select signal input pin with built-in pull-down resistor. Be sure to connect to 0V while it is not controlling.
64	TEST1	I	Test signal input pin without built-in pull-down resistor. Be sure to connect to 0V.

Note: The same potential must be applied to the respective power supply terminals. (VDD, VVDD, LVDD, RVDD, XVDD)

IC, CXD2652AR

Pin No.	Pin Name	I/O	Description
1	MNT0	O	Monitor output terminal.
2	MNT1	O	Monitor output terminal.
3	MNT2	O	Monitor output terminal.
4	MNT3	O	Monitor output terminal.
5	SWDT	I	Microprocessor serial interface data input.
6	SCLK	I	Microprocessor serial interface shift clock input.
7	XLAT	I	Microprocessor serial interface latch input. Latched at falling down edge.
8	SRDT	O	Microprocessor serial interface data output.
9	SENS	O	The terminal which outputs internal status in accordance with the address of the microprocessor serial interface.
10	XRST	I	Reset input. L: reset.
11	SQSY	O	Disc sub code Q sync/ADIP sync output.
12	DQSY	O	Subcode Q sync output of U-bit CD or MD format when the DIGITAL IN source is CD or MD.
13	RECP	I	Laser power selection input. H: Recording power, L: Playback power.
14	XINT	O	Interrupt request output terminal. L is output when interrupt status is generated.
15	TX	I	Record data output enable signal input terminal. H: enable.
16	OSCI	I	Crystal oscillator circuit input terminal.
17	OSCO	O	Crystal oscillator circuit output terminal. (Inverted output of OSCI).
18	XTSL	I	OSCI terminal input frequency selection. H: 512 Fs (22.5792 MHz), L: 1024 Fs (45.1584 MHz).
19	NC	—	Not connected.
20	DVSS	—	Digital GND.
21	DIN	I	Digital audio interface signal input.
22	DOUT	O	Digital audio interface signal output.
23	ADDT	I	Analog recording signal input terminal. (External A/D converter output is connected to this terminal).
24	DADT	O	RECORD monitor output/decode audio data output.
25	LRCK	O	LRCK (44.1 kHz) output terminal to external audio block.
26	XBCK	O	Bit clock output (2.8224 kHz) output terminal to external audio block.
27	FS256	O	256 Fs output. (11.2896 MHz).
28	DVDD	—	Digital power supply.
29	A03	O	Address output to external DRAM.
30	A02	O	Address output to external DRAM.
31	A01	O	Address output to external DRAM.
32	A00	O	Address output to external DRAM.
33	A10	O	Address output to external DRAM. (Not used).
34	A04	O	Address output to external DRAM.
35	A05	O	Address output to external DRAM.
36	A06	O	Address output to external DRAM.
37	A07	O	Address output to external DRAM.

Pin No.	Pin Name	I/O	Description
38	A08	O	Address output to external DRAM.
39	A11	O	Address output to external DRAM. (Not used).
40	DVSS	—	Digital GND.
41	XOE	O	External DRAM output enable.
42	XCAS	O	$\overline{\text{CAS}}$ output to external DRAM.
43	A09	O	Address output to external DRAM.
44	XRAS	O	$\overline{\text{RAS}}$ output to external DRAM.
45	XWE	O	Write enable for external DRAM.
46	D1	I/O	Data bus for external DRAM.
47	D0	I/O	Data bus for external DRAM.
48	D2	I/O	Data bus for external DRAM.
49	D3	I/O	Data bus for external DRAM.
50	MVCI	I	External VCO (784 fs) clock input.
51	ASYO	O	Playback EFM full swing output. (L: VSS, H: VDD).
52	ASYI	I	Playback EFM comparator slice voltage input.
53	AVDD	—	Analog GND.
54	BIAS	I	Playback EFM comparator bias current input.
55	RFI	I	Playback EFM RF signal input.
56	AVss	—	Analog power supply.
57	PDO	O	Phase comparison output to EFM decoder analog PLL.
58	PCO	O	Phase comparison output to the master PLL of playback digital PLL and to the recording EFM PLL.
59	FILI	I	Filter input to the master PLL of playback digital PLL and to the recording EFM PLL.
60	FILO	O	Filter output to the master PLL of playback digital PLL and to the recording EFM PLL.
61	CLTV	I	Internal VCO control voltage of the master PLL of playback digital PLL and of the recording EFM PLL.
62	PEAK	I	Optical light volume's peak hold signal input.
63	BOTM	I	Optical light volume's bottom hold signal input.
64	ABCD	I	Optical light volume signal input.
65	FE	I	Focus error signal input.
66	AUX1	I	Auxiliary input 1.
67	VC	I	Center terminal voltage input.
68	ADIO	O	Monitor output of A/D converter input signal.
69	AVDD	—	Analog power supply.
70	ADRT	I	Voltage input of the upper limit of the A/D converter operation range.
71	ADRB	I	Voltage input of the lower limit of the A/D converter operation range.
72	AVSS	—	Analog GND.
73	SE	I	Sled error signal input.
74	TE	I	Tracking error signal input.
75	AUX2	I	Auxiliary input 2.

Pin No.	Pin Name	I/O	Description
76	DCHG	I	Connected to the low impedance power supply.
77	APC	I	Error signal input to the laser digital APC.
78	ADFG	I	ADIP2 binary-converted FM signal (22.05±1 kHz) input.
79	F0CNT	O	Current source setting output terminal to CXA2523.
80	XLRF	O	Latch output for CXA2523 control. Latched at rise-up.
81	CKRF	O	Shift clock output for CXA2523 control.
82	DTRF	O	Data output for CXA2523 control.
83	APCREF	O	Reference PWM output to laser APC.
84	LDDR	O	PWM output to laser digital APC. (Not used).
85	TRDR	O	Tracking servo drive PWM output. (-).
86	TFDR	O	Tracking servo drive PWM output. (+).
87	DVDD	—	Digital power supply.
88	FFDR	O	Focus servo drive PWM output. (+).
89	FRDR	O	Focus servo drive PWM output. (-).
90	FS4	O	4 fs output. (176.4 kHz).
91	SRDR	O	Sled servo drive PWM output. (-).
92	SFDR	O	Sled servo drive PWM output. (+).
93	SPRD	O	Spindle servo drive PWM output. (PWM (-) or negative polarity).
94	SPFD	O	Spindle servo drive PWM output. (PWM (+) or PWM absolute value).
95	FGIN	I	FG input to spindle CAV servo.
96	TEST1	I	Test pin. Connected to GND.
97	TEST2	I	Test pin. Connected to GND.
98	TEST3	I	Test pin. Connected to GND.
99	DVSS	—	Digital GND.
100	EFMO	O	Low signal during playback. EFM (encode data) output: during recording.

IC, CXA2523AR

Pin No.	Pin Name	I/O	Description
1	I	I	Input "I" RF signal converted to I-V.
2	J	I	Input "J" RF signal converted to I-V.
3	VC	O	Output voltage for VCC/2.
4	A	I	Input current for main beam servo signal A.
5	B	I	Input current for main beam servo signal B.
6	C	I	Input current for main beam servo signal C.
7	D	I	Input current for main beam servo signal D.
8	E	I	Input current for side beam servo signal E.
9	F	I	Input current for side beam servo signal F.
10	PD	I	Input beam spectrum monitor signal.
11	APC	O	Output laser APC.
12	APCREF	I	Input reference voltage for laser power setting.
13	GND	—	GND.
14	TEMPI	I	Temperature sensor connection pin. (Not used)
15	TEMPR	I	Temperature sensor connection pin. Output reference voltage. (Not used)
16	SWDT	I	Input micro-processor serial interface data.
17	SCLK	I	Input micro-processor serial interface shift clock.
18	XLAT	I	Input micro-processor serial interface latch. "L": Latch.
19	XSTBY	I	Standby setting pin. "H": Normal mode, "L": Standby.
20	FOCNT	I	Internal current setting pin.
21	VREF	O	Output reference voltage. (Not used)
22	EQADJ	I/O	EQ central frequency setting pin.
23	3TADJ	I/O	BPF3T central frequency setting pin.
24	VCC	—	Power supply pin.
25	WBLADJ	I/O	BPF22 central frequency setting pin.
26	TE	O	Output tracking error signal.
27	CSLED	—	LPF capacitor connection pin for SLED error signal.
28	SE	O	Output SLED error signal.
29	ADFM	O	Output ADIP FM signal.
30	ADIN	I	Input ADIP signal comparator.
31	ADAGC	—	ADIPAGC capacitor connection pin.
32	ADFG	O	Output ADIP2 binary data signal.
33	AUX	O	13 output / Output temperature signal. Switched by serial command.
34	FE	O	Output focus error signal.
35	ABCD	O	Output beam spectrum signal for main beam servo detector.
36	BOTM	O	Output bottom hold signal for RF/ABCD.
37	PEAK	O	Output peak hold signal for RF/ABCD.
38	RF	O	RF equalizer output pin.
39	RF AGC	—	RFAGC capacitor connection pin.
40	AGCI	I	RFAGC input pin.
41	COMPO	O	User comparator output pin. (Not used)

Pin No.	Pin Name	I/O	Description
42	COMPP	I	User comparator non-inverted input pin. (Connected to GND)
43	ADDC	I/O	Capacitor connection pin for ADIP amplifier on return circuit.
44	OPO	O	Output pin for user operational amplifier. (Not used)
45	OPN	I	Non-inverted input pin for user operational amplifier.
46	RFO	O	RF amplifier output pin. Check point for eye pattern.
47	MORFI	I	Input pin where Groove RF signal is AC coupled.
48	MORFO	O	Output pin for Groove RF signal.

www.xiaoyu163.com

IC, CXP81952M

Pin No.	Pin Name	I/O	Description
1	MCAS	—	Not used.
2	MRAS	—	
3	BUP	—	
4	AMUTE	O	Audio mute signal output.
5	ESK	O	Serial clock output for EEPROM interface.
6	EDO	O	Serial data output for EEPROM interface.
7	EDI	I	Serial data input for EEPROM interface.
8	ECS	O	EEPROM interface chip select signal output.
9	—	—	Not used.
10	RFLCT	I	DISC reflectance factor detection switch input.
11	—	—	Not used.
12	LS	I	Optical pickup inner circumference detection switch input.
13	LDSW	I	Loading mechanism, EJECT position detection switch input.
14	PBSW	I	Loading mechanism, PB position detection switch input.
15	RECSW	I	Loading mechanism, RECORD position detection switch input.
16	—	—	Not used.
17	—	—	
18	ACOFF	—	
19	SREQ	I	System control send request signal input for system control interface.
20	EXTDIN	O	External DIGITAL-IN enable signal output.
21	SLOW	O	Loading mechanism speed control signal input.
22	LOAD	O	Loading mechanism operational direction control signal input 1.
23	EJECT	O	Loading mechanism operational direction control signal input 2.
24	MREQ	O	MD microprocessor send request signal output for system control interface.
25	DRIVE	O	EFM driver ON/OFF signal output.
26	—	—	Not used.
27	—	—	
28	—	—	
29	—	—	
30	—	—	
31	—	—	
32	—	—	
33	—	—	
34	—	—	
35	—	—	
36	—	—	
37	MP	—	Connected to VSS.
38	SRST	I	MD microprocessor reset signal input.
39	DGND	—	Connected to VSS.
40	XTALO	O	External system clock oscillation crystal connection terminal 1.
41	XTALI	I	External system clock oscillation crystal connection terminal 2.

Pin No.	Pin Name	I/O	Description
42	ARDY	I	Ready signal input for system control interface.
43	SIN	I	Serial data input for system control interface.
44	SOUT	O	Serial data output for system control interface.
45	ACLK	O	Serial clock output for system control interface.
46	XLAT	O	CXD2652 interface latch signal output.
47	XRST	O	CXD2652 reset signal output.
48	XSTBY	O	CXA2523 standby signal output.
49	—	—	Not used.
50	AVSS	—	Connected to VSS.
51	AVREF	—	Connected to VDD.
52	AVDD	—	
53	—	—	Not used. (PLL UP)
54	—	—	
55	—	—	
56	SLF	—	
57	SRF	—	
58	TEMP	—	
59	MAGIC	—	
60	—	—	
61	TEST	—	
62	DISCPRO	I	DISC write-protection switch input.
63	MNT3	I	CXD2652 monitor signal input 3.
64	MNT2	I	CXD2652 monitor signal input 2.
65	MNT1	I	CXD2652 monitor signal input 1.
66	MNT0	I	CXD2652 monitor signal input 0.
67	SENS	I	CXD2652 SENS signal input.
68	FLG	I	The terminal monitoring the flag included in the SRDT of the CXD2652 interface.
69	—	—	Not used.
70	—	—	
71	P-CONT	—	
72	RFSW	—	
73	—	—	
74	—	—	
75	DQSY	I	DIGITAL-IN SUB-Q sync input.
76	XINT	I	CXD2652 status sync input.
77	SRDT	I	CXD2652 interface serial data input.
78	SWDT	O	CXD2652 interface serial data output.
79	SCLK	O	CXD2652 interface serial clock output.
80	SQSY	I	SUB-Q, ADIP sync input.
81	—	—	Not used.
82	—	—	

Pin No.	Pin Name	I/O	Description
83	—	—	Not used.
84	TXI	—	Connected to VSS.
85	TXO	—	Open. (Not used)
86	VSS	—	Connected to VSS.
87	VDD	—	Connected to VDD.
88	NC	—	
89	—	—	Not used.
90	DRVMUTE	O	BA5970FP mute signal output.
91	—	—	Not used.
92	—	—	
93	—	—	
94	—	—	
95	RECP	O	Laser power selection signal output.
96	TX	O	Record data output enable signal output.
97	MOD	O	RF modulation circuit ON/OFF signal output.
98	OPMUTE	O	Laser mute signal output.
99	ARST	O	AK4512 reset signal output.
100	DENF	O	De-emphasis ON/OFF signal output.

www.xiaoyu163.com

IC BLOCK DIAGRAM
IC, BA3880FS

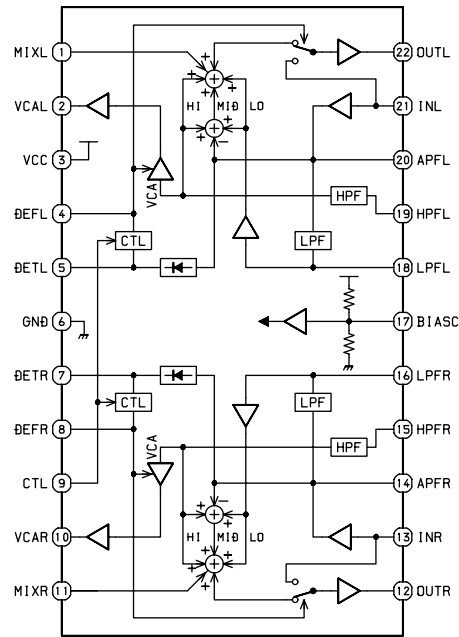

IC, MM1454XFBE

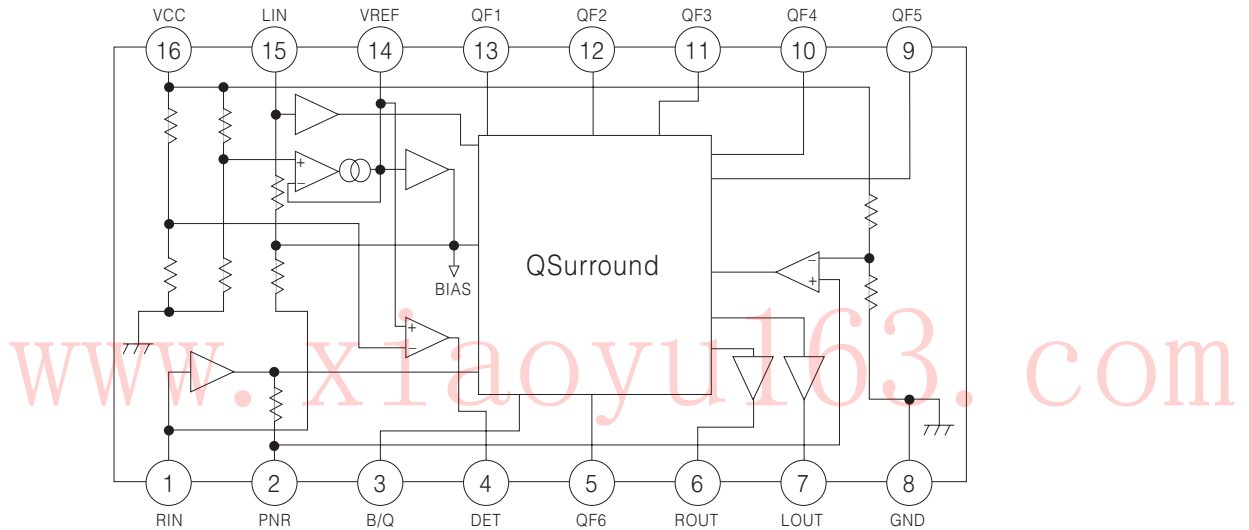

IC, M62495FP

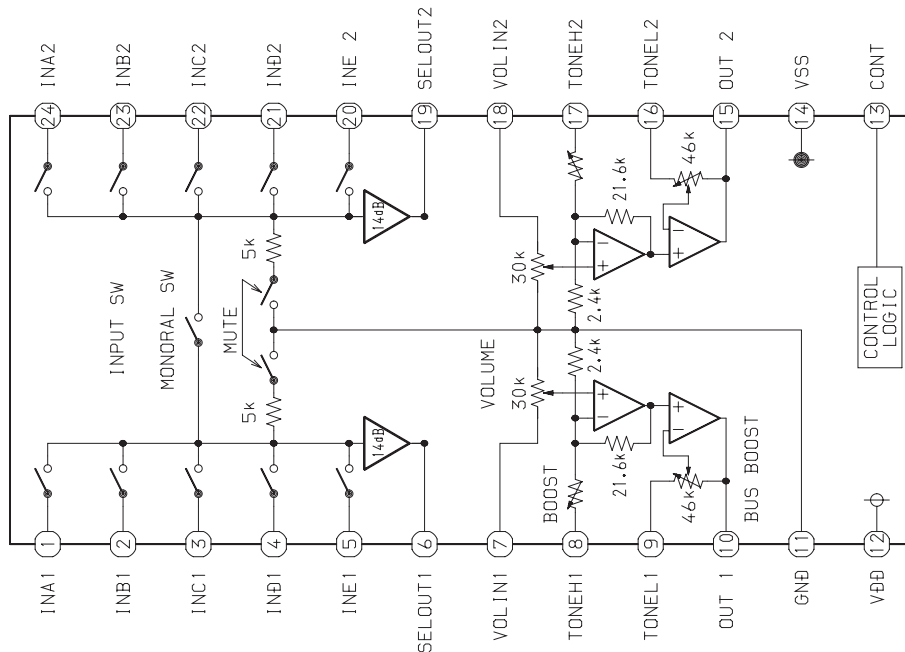

IC, BA5936

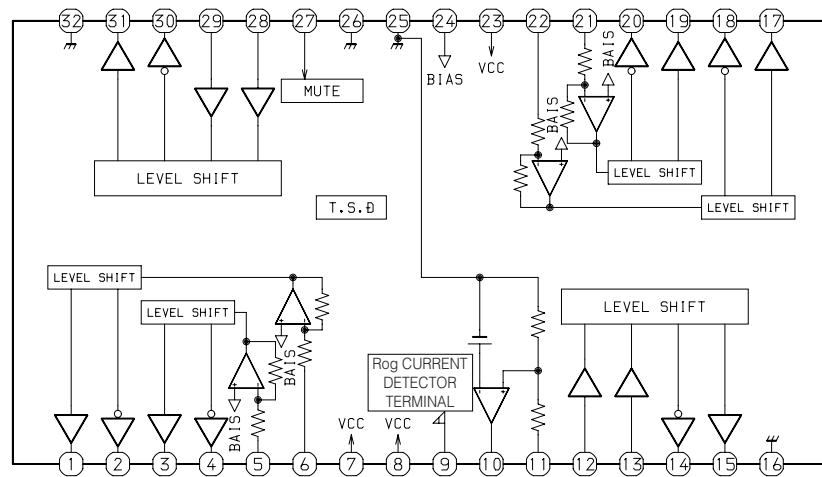

IC, BA5970FP

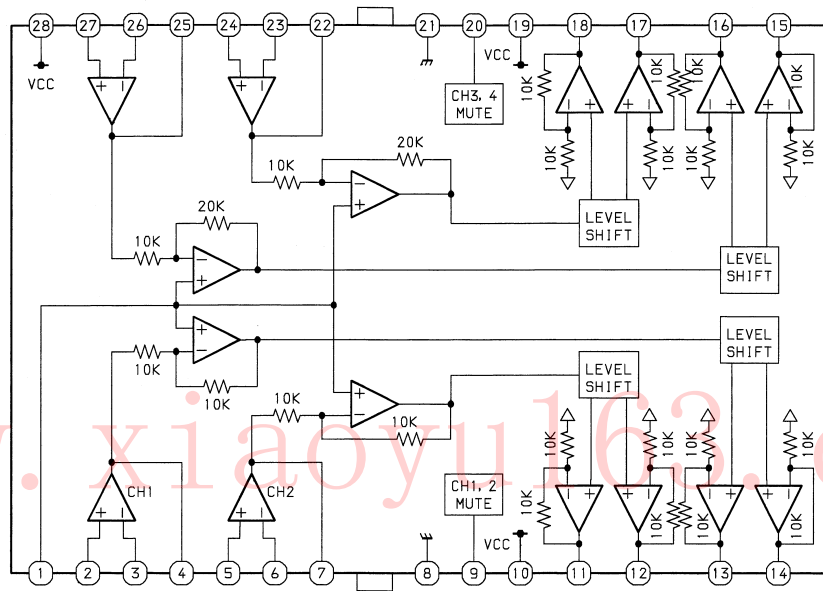

IC, BA6417F

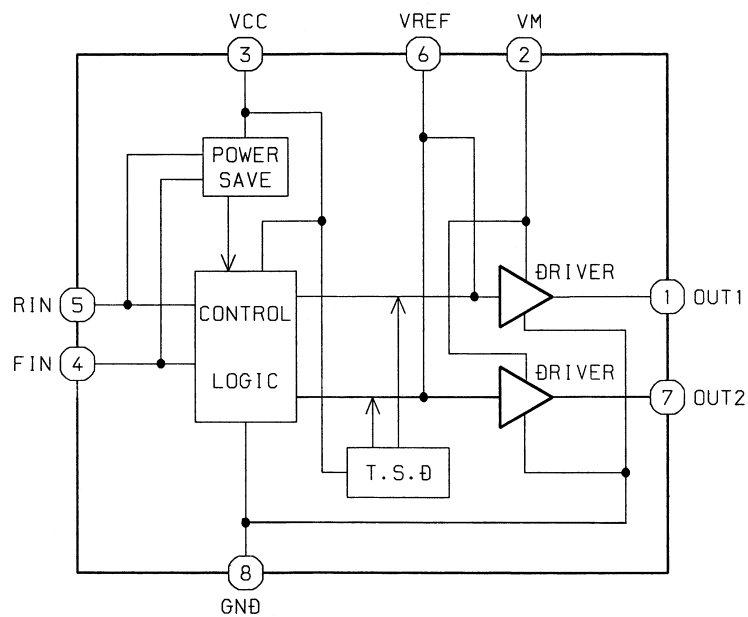

IC, BD7910FV

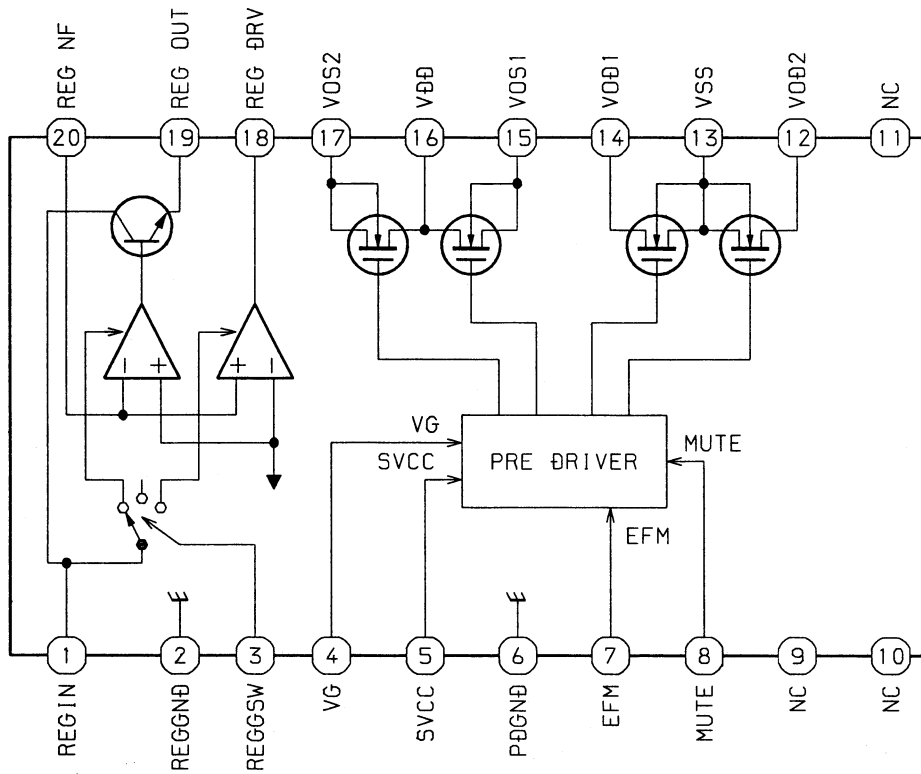

IC, AK4519VF

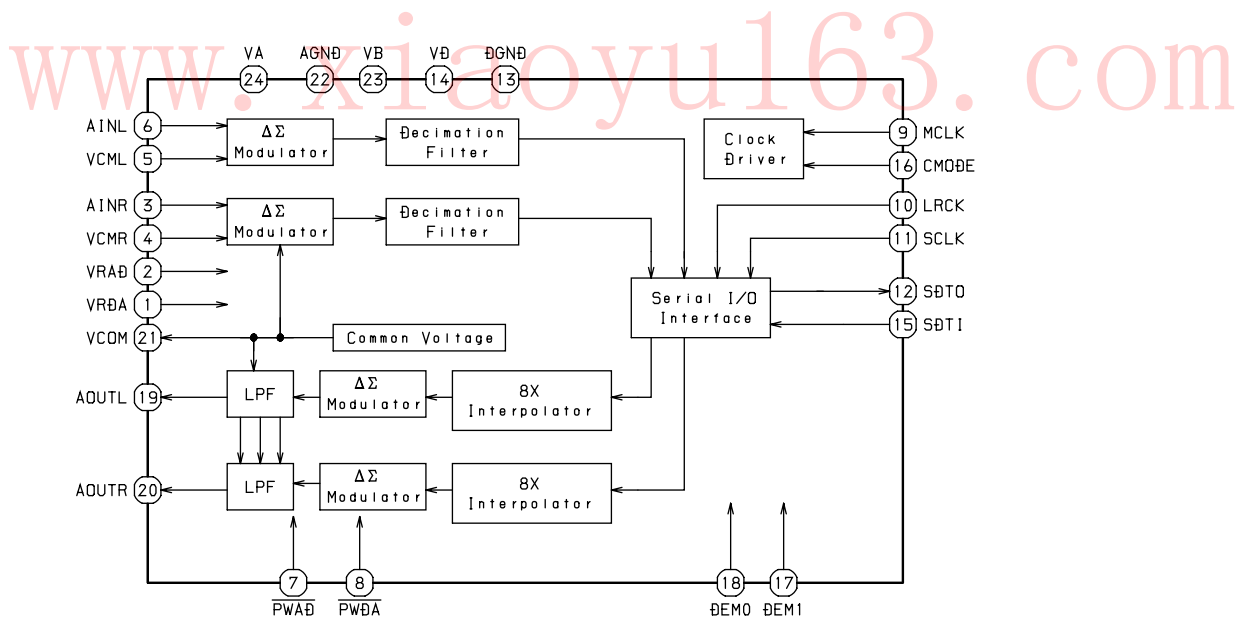

IC, CXA2523AR

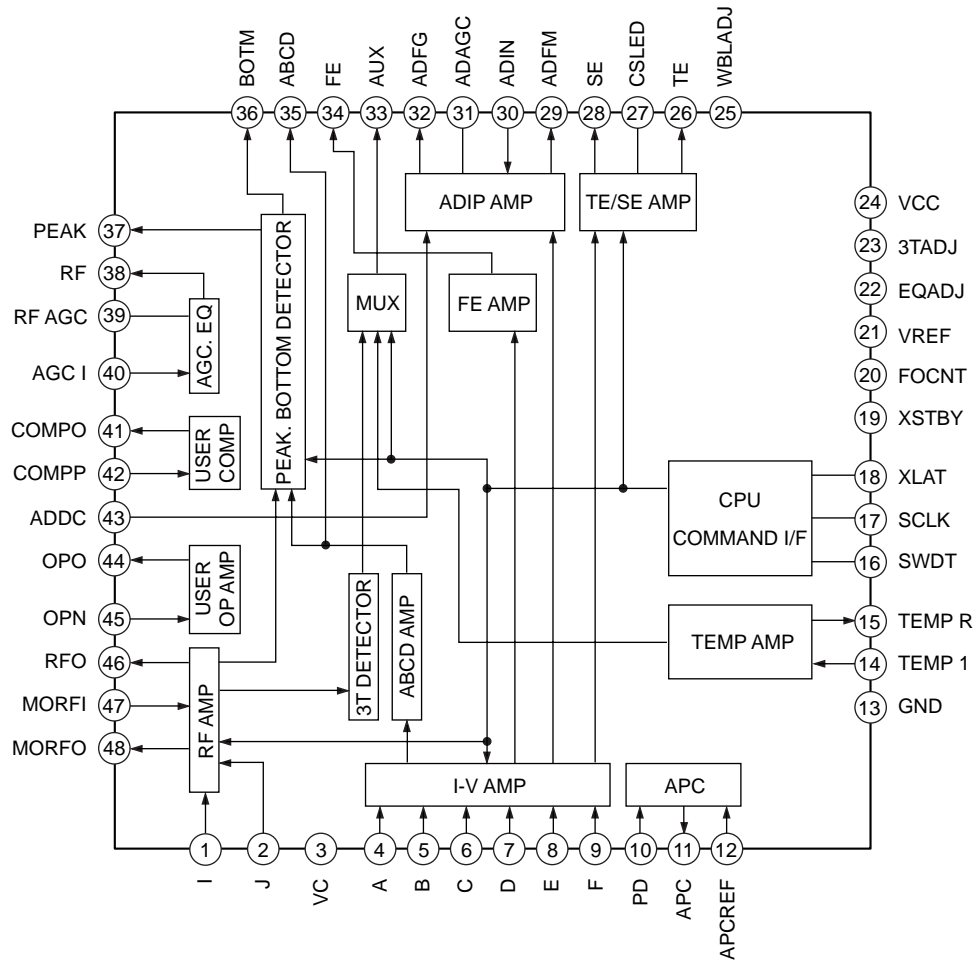

www.xiaoyu163.com

MECHANICAL EXPLODED VIEW 1/1

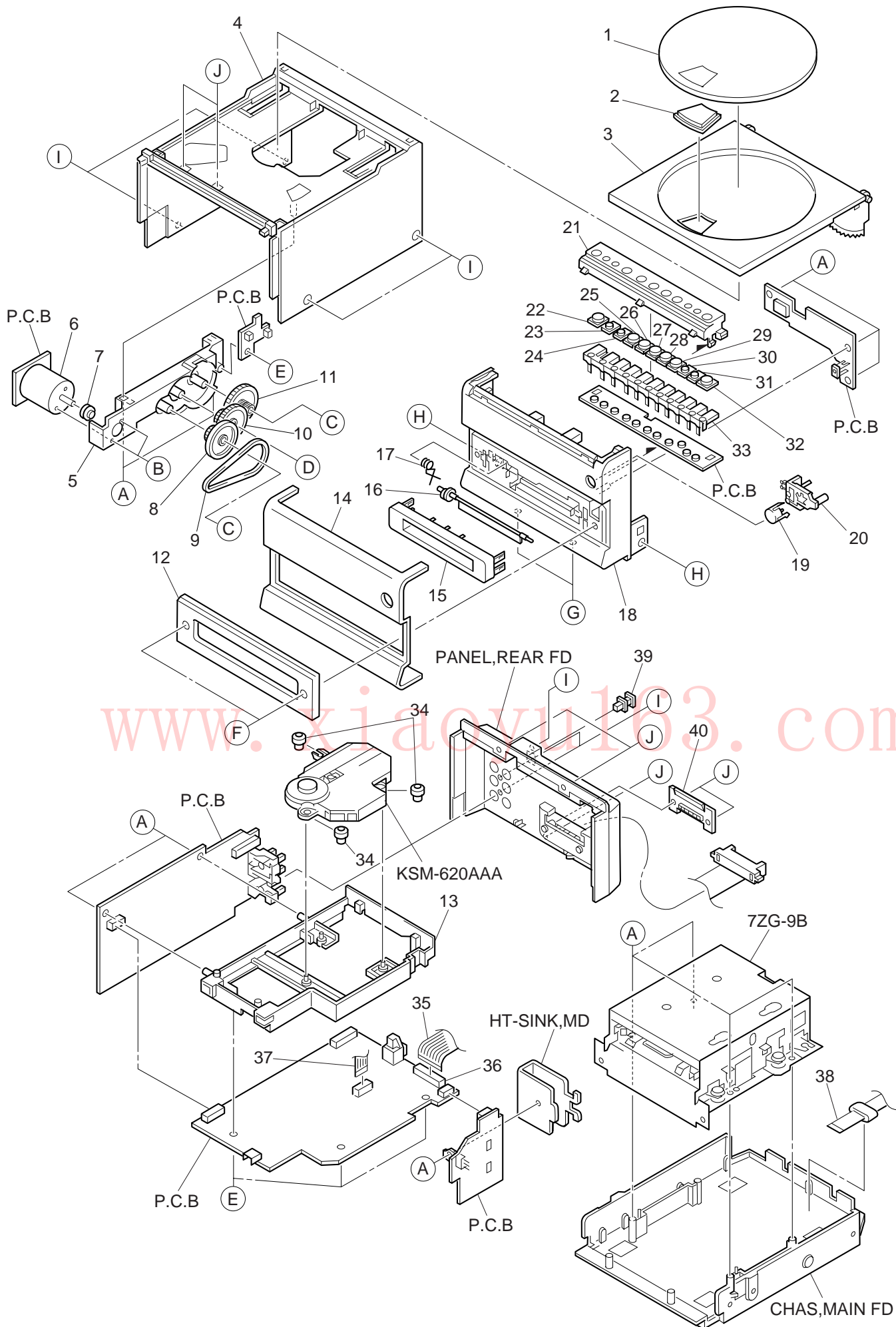

MECHANICAL PARTS LIST 1/1

DESCRIPTIONで判断できない物は "REFERENCE NAME LIST" を参照してください。
 If can't understand for Description please kindly refer to "REFERENCE NAME LIST".

REF. NO	PART NO.	KANRI NO.	DESCRIPTION	REF. NO	PART NO.	KANRI NO.	DESCRIPTION
1	8Z-CL1-014-010		PANEL,CD	26	8Z-CL1-020-010		CAP, STOP
2	8Z-CL1-012-010		WINDOW,CD	27	8Z-CL1-021-010		CAP, PLAY
3	8Z-CL1-004-010		CABI, TOP FD	28	8Z-CL1-022-010		CAP, REW
4	8Z-CL1-007-010		BOX,CD	29	8Z-CL1-023-010		CAP, FF
5	8Z-CL1-205-010		HLDR,GEAR	30	8Z-CL1-024-010		CAP, DOWN
6	87-A91-069-010		MOT,RF-370CA15370	31	8Z-CL1-025-010		CAP, UP
7	8Z-CL1-210-010		PULLEY,MOTOR	32	8Z-CL1-026-010		CAP, OPEN
8	8Z-CL1-211-010		PULLEY,CD	33	8Z-CL1-206-010		BTN,CONT
9	8Z-CL1-212-010		BELT,CD	34	88-HV1-207-010		DMPR,MECHA
10	8Z-CL1-209-010		GEAR,B	35	8Z-CL1-653-010		F-CABLE,19P 1.5 FG
11	8Z-CL1-208-010		GEAR,A	36	87-A90-878-010		HLDR,WIRE 19P 1.5 51016
12	8Z-CL1-011-010		WINDOW,MD	37	8Z-CL1-666-010		FF-CABLE, 8P 1.0
13	8Z-CL1-202-010		CHAS,CD	38	8Z-CL1-651-010		FF-CABLE, 14P 1.0
14	8Z-CL1-009-010		PANEL,FR FD	39	84-ZG1-245-210		CAP,OPTICAL
15	8Z-CL1-015-010		PANEL,MD	40	8Z-CL1-029-010		LID,CORD
16	88-CE2-012-010		PANEL,FLAP	A	87-067-703-010		TAPPING SCREW, BVT2+3-10
17	88-CE2-209-010		SPR-T,MD	B	87-261-092-210		V+3-4
18	8Z-CL1-002-010		CABI,FR FD	C	87-761-096-410		VFT2+3-10 GLD
19	8Z-CL1-028-010		CAP, EJECT	D	87-B10-162-010		VFT2+2-6
20	8Z-CL1-207-010		BTN,EJECT	E	87-067-579-010		BVT2+3-8
21	8Z-CL1-013-010		PANEL,CONT	F	8Z-CL1-034-010		S-SCREW,ZCL1
22	8Z-CL1-016-010		CAP, POWER	G	87-067-761-010		TAPPING SCREW, BVT2+3-10
23	8Z-CL1-017-010		CAP, FUNC	H	87-721-095-410		QT2+3-8GLD W/O SLOT
24	8Z-CL1-018-010		CAP, REC	I	87-744-095-410		UT2+3-8CR
25	8Z-CL1-019-010		CAP, PAUSE	J	87-B10-269-010		VT2+3-12

COLOR NAME TABLE

Basic color symbol	Color	Basic color symbol	Color	Basic color symbol	Color
B	Black	C	Cream	D	Orange
G	Green	H	Gray	L	Blue
LT	Transparent Blue	N	Gold	P	Pink
R	Red	S	Silver	ST	Titan Silver
T	Brown	V	Violet	W	White
WT	Transparent White	Y	Yellow	YT	Transparent Yellow
LM	Metallic Blue	LL	Light Blue	GT	Transparent Green
LD	Dark Blue	DT	Transparent Orange		

CD MECHANISM EXPLODED VIEW 1/1

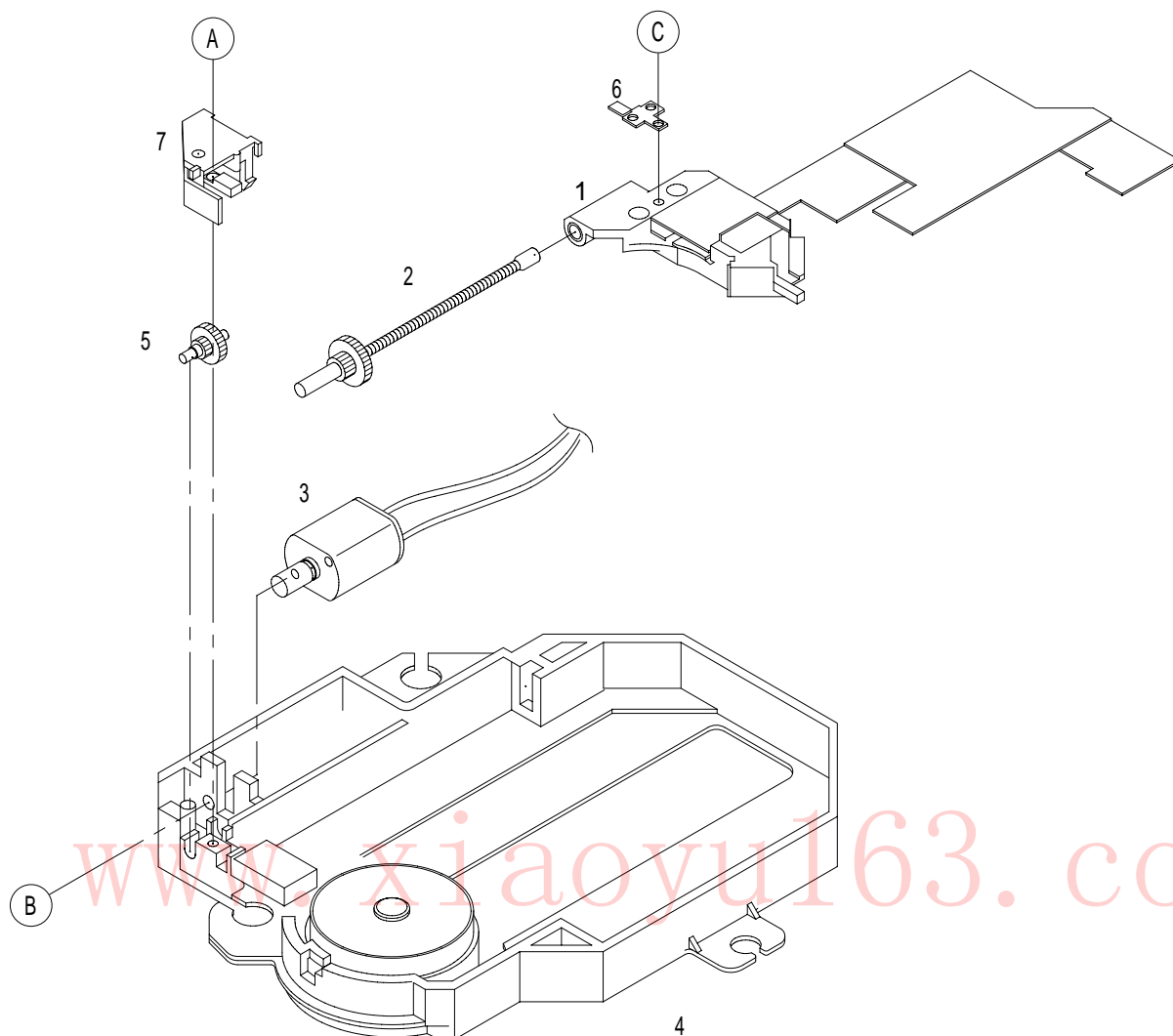

CD MECHANISM PARTS LIST 1/1

DESCRIPTIONで判断できない物は "REFERENCE NAME LIST" を参照してください。
 If can't understand for Description please kindly refer to "REFERENCE NAME LIST".

REF. NO	PART NO.	KANRI NO.	DESCRIPTION
1	98-820-063-030	KSS-620A(RP)	
2	9X-264-638-910	SLED SCREW ASSY	
3	9A-491-219-9A0	SLED MOTOR ASSY	
4	9X-264-648-210	MD ASSY	
5	92-627-751-020	GEAR BN	
6	92-646-914-010	LACK SPRING	
7	92-646-913-010	HOLDER	
A	92-646-352-010	TAPPING SCREW B2-8	
B	92-627-668-010	SCREW M2-2.5	
C	92-646-358-110	TAPPING SCREW B1.7-4	

MD MECHANISM EXPLODED VIEW 1/3

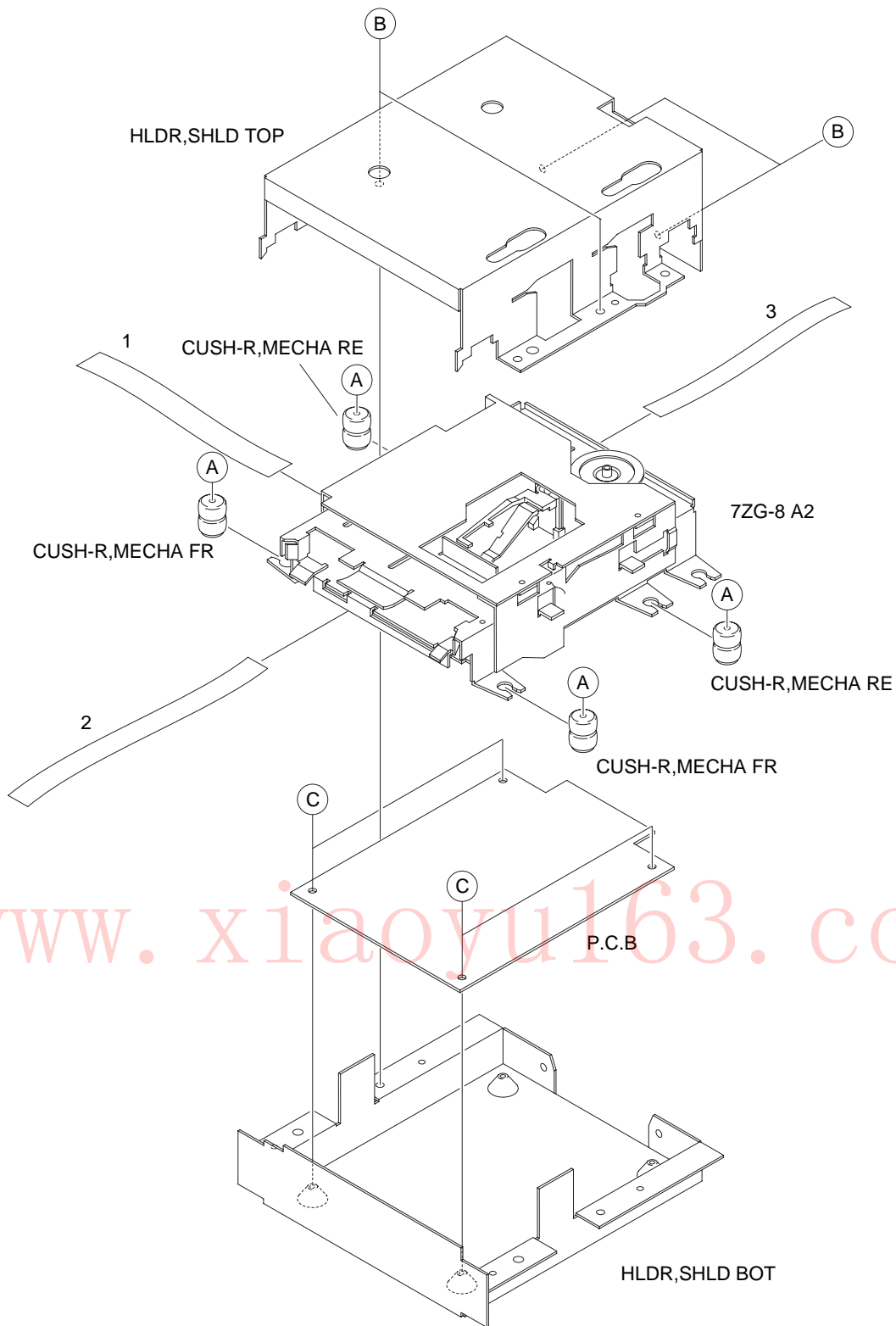

MD MECHANISM PARTS LIST 1/3

DESCRIPTIONで判断できない物は "REFERENCE NAME LIST" を参照してください。
 If can't understand for Description please kindly refer to "REFERENCE NAME LIST".

REF. NO	PART NO.	KANRI NO.	DESCRIPTION
1	87-ZG9-602-010		FF-CABLE,21P 0.5 90MM
2	87-ZG9-603-010		FF-CABLE,8P 1.0 120MM
3	87-ZG9-604-010		FF-CABLE,5P 1.25 100MM
A	87-ZG9-209-010		S-SCREW,MD TF
B	87-067-020-010		VTT+3-4
C	87-067-421-010		VTT+2-4

MD MECHANISM EXPLODED VIEW 2/3

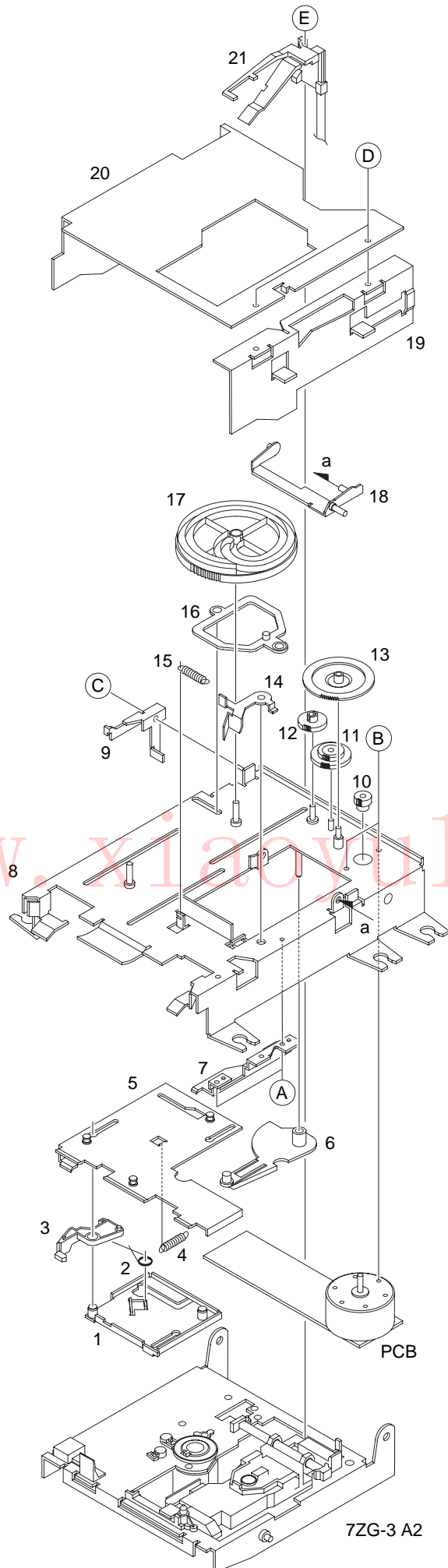

MD MECHANISM PARTS LIST 2/3

DESCRIPTIONで判断できない物は "REFERENCE NAME LIST" を参照してください。
 If can't understand for Description please kindly refer to "REFERENCE NAME LIST".

REF. NO	PART NO.	KANRI NO.	DESCRIPTION	REF. NO	PART NO.	KANRI NO.	DESCRIPTION
1	87-ZG8-220-110		PLATE ASSY,LATCH	16	87-ZG8-225-310		LEVER ASSY,CAM
2	87-ZG8-259-010		SPR-T,LATCH	17	87-ZG8-239-110		CAM,LOAD
3	87-ZG8-230-110		LEVER,LATCH	18	87-ZG8-257-210		LEVER ASSY,REC
4	87-ZG8-224-110		SPR-E,LATCH	19	87-ZG8-213-210		PLATE,SLIDE R
5	87-ZG8-214-210		HLDR ASSY,CARTRIGE	20	87-ZG8-209-210		PLATE ASSY,SLIDE L
6	87-ZG8-233-110		LEVER,SW H	21	87-A90-605-110		HEAD,OWH RF325-74A
7	87-ZG8-255-210		PLATE,CARTRIGE	A	87-B10-129-010		VTT+1.7-3.5 W/O MFZN2-C
8	87-ZG8-201-710		CHAS ASSY,MAIN	B	87-B10-128-010		V+1.7-2 W/O MFZN2-C
9	87-ZG8-256-110		LEVER,SW S2	C	87-B10-130-010		W-P,1.23-3.1-0.25 SLIT
10	87-ZG8-242-010		GEAR,MOT	D	87-067-421-010		VTT+2-4
11	87-ZG8-253-010		GEAR,REDUCTION S3	E	87-B10-131-010		VW+1.7-5 W/O MFZN2C
12	87-ZG8-246-010		GEAR,IDLER 2				
13	87-ZG8-252-010		GEAR,REDUCTION L3				
14	87-ZG8-231-010		LEVER,SHUTTER				
15	87-ZG8-232-110		SPR-E,SHUTTER				

www.xiaoyu163.com

MD MECHANISM EXPLODED VIEW 3/3

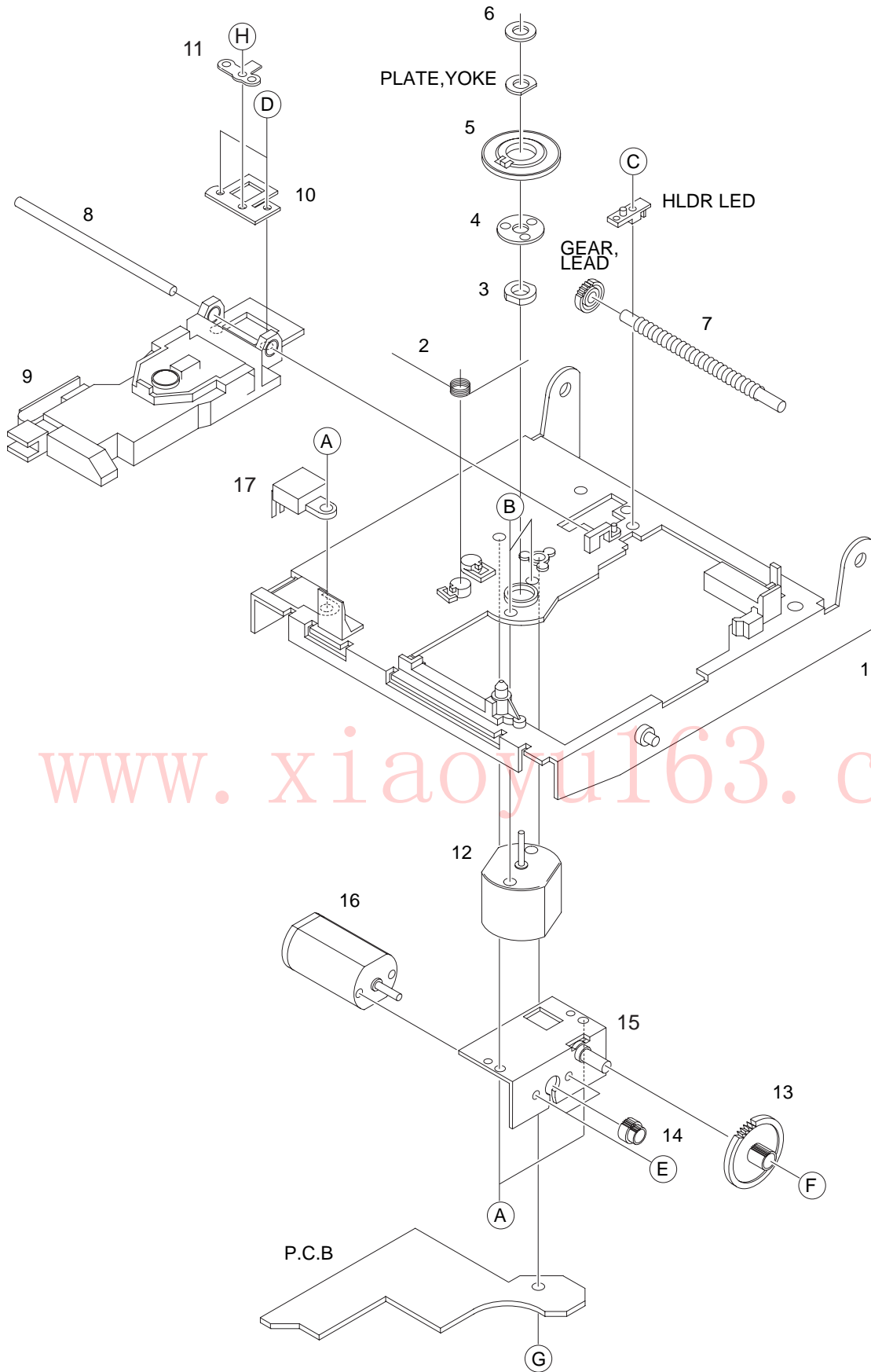

www.xiaoyu163.com

MD MECHANISM PARTS LIST 3/3

DESCRIPTIONで判断できない物は "REFERENCE NAME LIST" を参照してください。
 If can't understand for Description please kindly refer to "REFERENCE NAME LIST".

REF. NO	PART NO.	KANRI NO.	DESCRIPTION	REF. NO	PART NO.	KANRI NO.	DESCRIPTION
1	87-ZG3-202-510		CHAS ASSY,OUT-SERT	16	87-A90-616-010		MOT,FF-N30VA
2	87-ZG3-214-210		SPR-T,SPINDLE-A	17	87-A90-611-010		SW,PUSH 3-2-2 MPU20300MLB0
3	83-ZG5-308-010		BRG,1.5-2	A	87-261-547-310		V+2-3 BLK (1)
4	83-ZG5-302-110		TURN TABLE,MD1	B	87-263-523-310		SCREW, V+1.7-2
5	83-ZG5-305-210		SPR-P,DISC	C	87-261-509-310		SCREW, V+1.4-4
6	83-ZG5-605-010		MAGNET,CHUCK	D	87-067-393-010		SCREW +1.4-1.4
7	87-ZG3-212-110		SHAFT,LEAD	E	87-261-503-310		PRECISION SCREW, V+1.4-2
8	87-ZG3-211-010		SHAFT,GUIDE	F	87-078-033-010		PW 1.2-2.5-0.25 SLT
9	87-A90-613-010		PICKUP,KMS-260A	G	87-341-035-210		SCREW,UT1+2-6
10	87-ZG3-216-010		SPR-P,RACK	H	87-264-523-010		SCREW,V+1.7-2
11	87-ZG3-213-010		SPR-P,LEAD				
12	87-A90-413-010		MOT,FF-110PH 9				
13	87-ZG3-206-010		GEAR,A				
14	87-ZG3-205-010		GEAR,MOT SL				
15	87-ZG3-208-010		HLDR ASSY,MOTOR				

www.xiaoyu163.com

MODEL NO. SX-LMD200

SPEAKER DISASSEMBLY INSTRUCTIONS

Type.1

Insert a flat-bladed screwdriver into the position indicated by the arrows and remove the panel. Remove the screws of each speaker unit and then remove the speaker units.

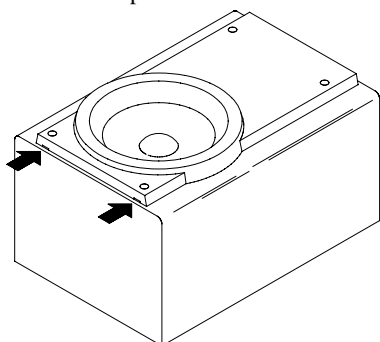

Type.2

Remove the grill frame and four pieces of rubber caps by pulling out with a flat-bladed screwdriver. Remove the screws from hold where installed rubber caps. Insert a flat-bladed screwdriver into the position indicated by the arrows and remove the panel. Remove the screws of each speaker unit and then remove the speaker units.

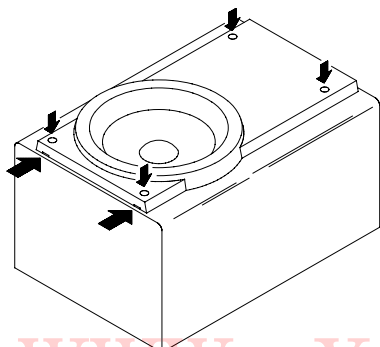

Type.3

Insert a flat-bladed screwdriver into the position indicated by the arrows and remove the panel. Turn the speaker unit to counter-clockwise direction while inserting a flat-bladed screwdriver into one of the hollows around speaker unit, and then remove the speaker unit. After replacing the speaker unit, install it turning to clockwise direction until "click" sound comes out.

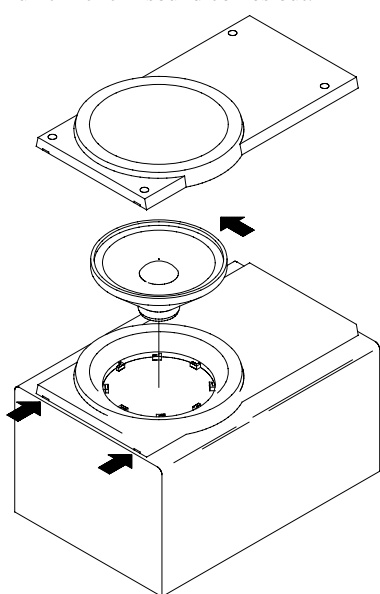

Type.4

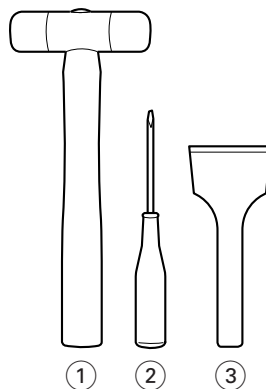

TOOLS

- ① Plastic head hammer
- ② (⊖) flat head screwdriver
- ③ Cut chisel

How to Remove the PANEL, FR

1. Insert the (⊖) flat head screwdriver tip into the gap between the PANEL, FR and the PANEL, SPKR. Tap the head of the (⊖) flat head screwdriver with the plastic hammer head, and create the clearance as shown in Fig-1.
2. Insert the cut chisel in the clearance, and tap the head of the cut chisel with plastic hammer as shown in Fig-2, to remove the PANEL, FR.
3. Place the speaker horizontally. Tap head of the cut chisel with plastic hammer as shown in Fig-3, and remove the PANEL, FR completely.

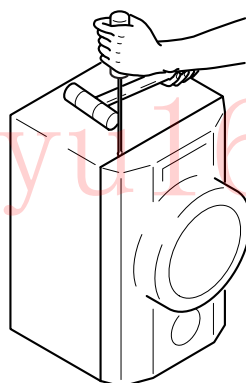

Fig-1

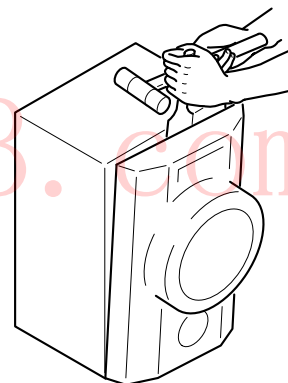

Fig-2

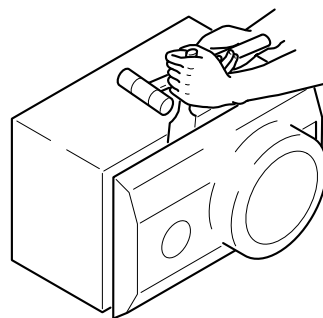

Fig-3

How to Attach the PANEL, FR

Attach the PANEL, FR to the PANEL, SPKR. Tap the four corners of the PANEL, FR with the plastic hammer to fit the PANEL, FR into the PANEL, SPKR completely.

SPEAKER PARTS LIST 1/1

DESCRIPTIONで判断できない物は "REFERENCE NAME LIST" を参照してください。
If can't understand for Description please kindly refer to "REFERENCE NAME LIST".

REF. NO	PART NO.	KANRI NO.	DESCRIPTION
1	8Z-CP1-012-010		CORD, SP
2	8Z-CP1-006-010		GRILLE, FRAME ASSY<YJTN>
2	8Z-CP1-017-010		GRILLE, FRAME ASSY B<YJBN>
3	8Z-CP1-003-010		PANEL, FR<YJTN>
3	8Z-CP1-015-010		PANEL, FR B<YJBN>
4	8Z-CP1-005-010		PANEL, TW<YJTN>
4	8Z-CP1-016-010		PANEL, TW B<YJBN>
5	8Z-CP1-601-010		SPKR, W 100
6	88-CL1-937-010		SPKR, TW 25

www.xiaoyu163.com

www.xiaoyu163.com

サービス技術ニュース	
番号	連絡内容
G- -	
G- -	
G- -	

アイワ株式会社 〒110 東京都台東区池之端1-2-11 ☎03 (3827) 3111 (代表)
AIWA CO.,LTD. 2-11, IKENOHATA 1-CHOME, TAITO-KU, TOKYO 110, JAPAN TEL:03 (3827) 3111