

aiwa



XR-MD700 XR-M99

MD/CD STEREO SYSTEM

- TYPE:MD700<D>
M99<LH,U>

SIMPLE MANUAL

TYPE	AMPLIFIER	TUNER	CD PLAYER	MD RECORDER	SPEAKERS
D	MX-LM700	TX-LM700	DX-LM700	AM-LM700	SX-LM99
LH	MX-LM99	TX-LM99	DX-LM99	—	SX-LM99
U	MX-LM99	TX-LM99	DX-LM99	—	SX-LM99

- Replace this Service Manual with "Revision Publishing" when it is issued.

ELECTRICAL MAIN PARTS LIST - 1/3(MX-LM700/99)

NOTE: The characters in the suffix column indicate the part usage.

REF.NO	PARTS NO.	KANRI NO.	DESCRIPTION	SUFFIX
D	OO	A
LH	XX	B
U	XX	C
C	302	87-010-197-080	0E CAP, CHIP 0.01 DM	ABC
C	301	87-010-197-080	0E CAP, CHIP 0.01 DM	ABC
C	303	87-010-260-080	0E CAP, ELECT 47-25V	ABC
CN	204	87-A60-131-010	0E CONN, 6P V FE	ABC
CN	304	87-A60-131-010	0E CONN, 6P V FE	ABC
CN	305	87-A60-619-010	0E CONN, 2P V 2MM JMT	ABC
CN	306	87-A60-619-010	0E CONN, 2P V 2MM JMT	ABC
CN	302	88-805-020-790	CONN ASSY, 2P 70MM	ABC
CN	301	88-805-020-790	CONN ASSY, 2P 70MM	ABC
D	307	87-A40-291-080	0E DIODE, 1N4148 (CPT)	ABC
D	301	87-A40-299-080	0E ZENER, DZ5.1M	ABC
D	302	87-A40-317-080	0E LED, SLR-342VCT31 RED	ABC
D	303	87-A40-640-010	1E LED, SELU1E10CXM BLUE-EF	ABC
D	304	87-A40-640-010	1E LED, SELU1E10CXM BLUE-EF	ABC
D	305	87-A40-640-010	1E LED, SELU1E10CXM BLUE-EF	ABC
D	306	87-A40-640-010	1E LED, SELU1E10CXM BLUE-EF	ABC
Q	302	87-A30-087-080	0E C-FET, 2SK2158	ABC
S	309	87-A90-696-080	0E SW, TACT TS2103-03-430	ABC
S	306	87-A90-696-080	0E SW, TACT TS2103-03-430	ABC
S	307	87-A90-696-080	0E SW, TACT TS2103-03-430	ABC
S	308	87-A90-696-080	0E SW, TACT TS2103-03-430	ABC
S	305	87-A90-696-080	0E SW, TACT TS2103-03-430	ABC
S	303	87-A90-696-080	0E SW, TACT TS2103-03-430	ABC
S	302	87-A90-696-080	0E SW, TACT TS2103-03-430	ABC
S	304	87-A90-696-080	0E SW, TACT TS2103-03-430	ABC
S	301	87-A91-402-010	SW, RTRY RE0121PVB25FINA1-T2	ABC
C	104	87-010-387-080	1A CAP, E 470-25 SME	ABC
C	105	87-010-403-080	0E CAP, ELECT 3.3-50V	ABC
C	101	87-A10-479-080	0E CAP, CER 2200P-250 M E KH	.B
C	102	87-A10-479-080	0E CAP, CER 2200P-250 M E KH	ABC
CN	104	87-A61-024-010	CONN, 4P H BLK TKC-M	ABC
D	106	87-A40-291-080	0E DIODE, 1N4148 (CPT)	ABC
D	103	87-A40-291-080	0E DIODE, 1N4148 (CPT)	ABC
D	104	87-A40-291-080	0E DIODE, 1N4148 (CPT)	ABC
D	105	87-A40-291-080	0E DIODE, 1N4148 (CPT)	ABC
D	102	87-A40-291-080	0E DIODE, 1N4148 (CPT)	ABC
D	107	87-A40-291-080	0E DIODE, 1N4148 (CPT)	ABC
D	101	87-A40-291-080	0E DIODE, 1N4148 (CPT)	ABC
F	101	87-A91-276-080	1B FUSE, 125MA 125V F 251	.C
PT	101	8Z-NF8-660-010	1C PT, SUB ZNF-8(D)	A
PT	101	8Z-NF8-661-010	1D PT, SUB ZNF-8(U)	.C
PT	101	8Z-NF8-663-010	1D PT, SUB ZNF-8(H)	.B
Q	101	87-026-245-080	0E TR, DTC114ES	ABC
Q	102	87-A30-198-080	0E TR, KTC3199GR	ABC
RY	101	87-A90-976-010	1B RELAY, AC12V SDT-S-112LMR	ABC
RY	101	87-A91-288-010	1E RELAY, AC12V DG12D2-O(M)	.B
S	101	87-A90-234-010	1A SW, SL 1-2-2 SW2201	.B
TM	102	87-A60-317-010	0E TERMINAL, 1P MSC	ABC
TM	101	87-A60-317-010	0E TERMINAL, 1P MSC	ABC
C	82	87-010-263-080	0E CAP, ELECT 100-10V	ABC
C	84	87-010-378-040	0E CAP, E 10-16	ABC
C	83	87-010-380-080	0E CAP, ELECT 47-16V	ABC
C	81	87-010-401-080	0E CAP, ELECT 1-50V	ABC
CN	202	87-A60-109-010	0E CONN, 2P V S2M-2W	ABC
D	81	87-A40-291-080	0E DIODE, 1N4148 (CPT)	ABC
D	82	87-A40-291-080	0E DIODE, 1N4148 (CPT)	ABC
D	83	87-A40-291-080	0E DIODE, 1N4148 (CPT)	ABC
D	85	87-A40-291-080	0E DIODE, 1N4148 (CPT)	ABC
Q	82	87-026-609-080	0E TR, KTA1266GR	ABC
Q	83	87-026-609-080	0E TR, KTA1266GR	ABC
Q	81	87-A30-076-080	0E C-TR, 2SC3052F	ABC
C	128	87-010-196-080	0E CHIP CAPACITOR, 0.1-25	ABC
C	126	87-010-196-080	0E CHIP CAPACITOR, 0.1-25	ABC
C	127	87-010-196-080	0E CHIP CAPACITOR, 0.1-25	ABC
C	125	87-010-196-080	0E CHIP CAPACITOR, 0.1-25	ABC
C	129	87-010-928-090	1B CAP, E 4700-25 SMG	ABC
C	124	87-A10-520-090	1B CAP, E 3300-35 M SMG	ABC
C	123	87-A10-520-090	1B CAP, E 3300-35 M SMG	ABC
C	131	87-010-384-080	0E CAP, ELECT 100-25V	ABC
C	130	87-010-384-080	0E CAP, ELECT 100-25V	ABC
C	153	87-010-196-080	0E CHIP CAPACITOR, 0.1-25	ABC
C	151	87-010-196-080	0E CHIP CAPACITOR, 0.1-25	ABC
C	154	87-A10-105-080	0E CAP, E 1000-6.3 REA	ABC
C	152	87-A11-233-090	1B CAP, E 4700-16 105 KMG	ABC
C	176	87-010-247-080	0E CAP, ELECT 100-50V	ABC
C	175	87-010-247-080	0E CAP, ELECT 100-50V	ABC
C	171	87-010-260-080	0E CAP, ELECT 47-25V	ABC
C	173	87-010-260-080	0E CAP, ELECT 47-25V	ABC
C	174	87-010-260-080	0E CAP, ELECT 47-25V	ABC
C	172	87-010-260-080	0E CAP, ELECT 47-25V	ABC
C	182	87-010-384-080	0E CAP, ELECT 100-25V	ABC
C	181	87-010-384-080	0E CAP, ELECT 100-25V	ABC
CN	103	87-049-469-010	0E CONN, 4P V	ABC
CN	102	87-099-186-010	0E CONN, 6P EH V WHT	ABC

ELECTRICAL MAIN PARTS LIST - 2/3(MX-LM700/99)

CN	101	87-A61-025-010	CONN,4P TKC-M4P-B1	ABC.....
D	122	87-070-178-090	0E DIODE,1N5402-BD54	ABC.....
D	123	87-070-178-090	0E DIODE,1N5402-BD54	ABC.....
D	124	87-070-178-090	0E DIODE,1N5402-BD54	ABC.....
D	121	87-070-178-090	0E DIODE,1N5402-BD54	ABC.....
D	126	87-070-274-080	0E DIODE,1N4003 SEM	ABC.....
D	125	87-070-274-080	0E DIODE,1N4003 SEM	ABC.....
D	153	87-017-083-080	0E ZENER,HZS4C2	ABC.....
D	152	87-070-274-080	0E DIODE,1N4003 SEM	ABC.....
D	151	87-070-274-080	0E DIODE,1N4003 SEM	ABC.....
D	172	87-070-274-080	0E DIODE,1N4003 SEM	ABC.....
D	174	87-070-274-080	0E DIODE,1N4003 SEM	ABC.....
D	171	87-070-274-080	0E DIODE,1N4003 SEM	ABC.....
D	173	87-070-274-080	0E DIODE,1N4003 SEM	ABC.....
D	175	87-A40-312-080	0E ZENER,DZ33M	ABC.....
D	181	87-A40-001-080	0E ZENER,MTZJ12C	ABC.....
D	182	87-A40-001-080	0E ZENER,MTZJ12C	ABC.....
IC	121	87-001-642-010	1B IC,NJM78M12FA	ABC.....
IC	122	87-001-642-010	1B IC,NJM78M12FA	ABC.....
PR	104	87-026-681-080	0E PROTECTOR,5A 60V 491	AB.....
PR	103	87-026-681-080	0E PROTECTOR,5A 60V 491	AB.....
PR	103	87-026-690-080	1A FUSE,5A 125V 251	..C.....
PR	104	87-026-690-080	1A FUSE,5A 125V 251	..C.....
PR	152	87-A90-094-080	0E PROTECTOR,4A 491SERIES 60V	AB.....
PR	151	87-A90-094-080	0E PROTECTOR,4A 491SERIES 60V	AB.....
PR	152	87-A90-113-080	1A PROTECTOR,4A 251	..C.....
PR	151	87-A90-113-080	1A PROTECTOR,4A 251	..C.....
Q	126	87-A30-075-080	0E C-TR,2SA1235F	ABC.....
Q	152	87-A30-076-080	0E C-TR,2SC3052F	ABC.....
Q	153	87-A30-076-080	0E C-TR,2SC3052F	ABC.....
Q	151	89-213-702-010	1A TR,2SB1370 (1.8W)	ABC.....
Q	172	87-026-609-080	0E TR,KTA1266GR	ABC.....
Q	171	87-026-609-080	0E TR,KTA1266GR	ABC.....
C	53	87-010-197-080	0E CAP,CHIP 0.01 DM	ABC.....
C	51	87-010-260-080	0E CAP,ELECT 47-25V	ABC.....
C	52	87-010-403-080	0E CAP,ELECT 3.3-50V	ABC.....
C	207	87-010-546-080	0E CAP,ELECT 0.33-50V	ABC.....
C	208	87-010-546-080	0E CAP,ELECT 0.33-50V	ABC.....
C	214	87-010-186-080	0E CAP,CHIP 4700P	ABC.....
C	213	87-010-186-080	0E CAP,CHIP 4700P	ABC.....
C	211	87-010-260-080	0E CAP,ELECT 47-25V	ABC.....
C	212	87-010-260-080	0E CAP,ELECT 47-25V	ABC.....
C	216	87-010-403-080	0E CAP,ELECT 3.3-50V	ABC.....
C	215	87-010-403-080	0E CAP,ELECT 3.3-50V	ABC.....
C	217	87-A10-946-080	0E C-CAP,S 220P-100 J CH	ABC.....
C	218	87-A10-946-080	0E C-CAP,S 220P-100 J CH	ABC.....
C	229	87-010-182-080	0E C-CAP,S 2200P-50 B	ABC.....
C	222	87-010-186-080	0E CAP,CHIP 4700P	ABC.....
C	221	87-010-186-080	0E CAP,CHIP 4700P	ABC.....
C	225	87-010-195-080	0E C-CAP,S 0.068-25 F	ABC.....
C	226	87-010-195-080	0E C-CAP,S 0.068-25 F	ABC.....
C	228	87-010-544-080	0E CAP,ELECT 0.1-50V	ABC.....
C	227	87-010-544-080	0E CAP,ELECT 0.1-50V	ABC.....
C	223	87-012-368-080	0E C-CAP,S 0.1-50 F	ABC.....
C	224	87-012-368-080	0E C-CAP,S 0.1-50 F	ABC.....
C	230	87-010-182-080	0E C-CAP,S 2200P-50 B	ABC.....
C	234	87-010-380-080	0E CAP,ELECT 47-16V	ABC.....
C	271	87-010-112-080	0E CAP,ELECT 100-16V	ABC.....
C	270	87-010-380-080	0E CAP,ELECT 47-16V	ABC.....
CN	205	87-009-802-010	CONN,20P H BLK TKC-M	ABC.....
CN	203	87-099-548-010	CONN,20P TKC-M020P-B	ABC.....
CN	206	87-A60-624-010	0E CONN,7P V 2MM JMT	ABC.....
CN	201	87-A61-039-010	CONN,19P V WHT 52328	ABC.....
CN	207	88-805-071-290	CONN ASSY,7P	ABC.....
CN	201	8Z-CE3-610-010	CONN ASSY,19P 52305-1911	ABC.....
D	53	87-A40-004-080	0E ZENER,MTZJ16A	ABC.....
D	52	87-A40-269-080	0E C-DIODE,MC2836	ABC.....
D	51	87-A40-270-080	0E C-DIODE,MC2838	ABC.....
D	54	87-A40-291-080	0E DIODE,1N4148 (CPT)	ABC.....
D	55	87-A40-291-080	0E DIODE,1N4148 (CPT)	ABC.....
D	209	87-A40-270-080	0E C-DIODE,MC2838	ABC.....
D	207	87-A40-291-080	0E DIODE,1N4148 (CPT)	ABC.....
D	208	87-A40-291-080	0E DIODE,1N4148 (CPT)	ABC.....
D	204	87-A40-291-080	0E DIODE,1N4148 (CPT)	ABC.....
D	202	87-A40-291-080	0E DIODE,1N4148 (CPT)	ABC.....
D	203	87-A40-291-080	0E DIODE,1N4148 (CPT)	ABC.....
D	201	87-A40-291-080	0E DIODE,1N4148 (CPT)	ABC.....
D	205	87-A40-488-080	0E DIODE,1SS244	ABC.....
D	206	87-A40-488-080	0E DIODE,1SS244	ABC.....
D	212	87-A40-291-080	0E DIODE,1N4148 (CPT)	ABC.....
D	210	87-A40-291-080	0E DIODE,1N4148 (CPT)	ABC.....
D	211	87-A40-291-080	0E DIODE,1N4148 (CPT)	ABC.....
J	202	87-099-801-010	0E JACK,PIN 1P BLK	ABC.....
J	201	87-A60-420-010	1A JACK,3.5 ST (MSC)	ABC.....
J	203	87-A60-659-010	1B TERMINAL,SPKR 4P HSP-134V-05Z	ABC.....
L	202	87-003-383-010	1A COIL,1UH-S	ABC.....
L	201	87-003-383-010	1A COIL,1UH-S	ABC.....
Q	58	87-A30-074-080	0E C-TR,RT1P 141C	ABC.....
Q	54	87-A30-075-080	0E C-TR,2SA1235F	ABC.....
Q	52	87-A30-075-080	0E C-TR,2SA1235F	ABC.....
Q	55	87-A30-076-080	0E C-TR,2SC3052F	ABC.....
Q	51	87-A30-076-080	0E C-TR,2SC3052F	ABC.....

ELECTRICAL MAIN PARTS LIST - 3/3(MX-LM700/99)

Q	53	87-A30-076-080	0E	C-TR, 2SC3052F	ABC.....
Q	56	87-A30-268-040	0E	C-TR, 2SA1514K(S)	ABC.....
Q	57	87-A30-268-040	0E	C-TR, 2SA1514K(S)	ABC.....
Q	201	87-A30-075-080	0E	C-TR, 2SA1235F	ABC.....
Q	202	87-A30-075-080	0E	C-TR, 2SA1235F	ABC.....
Q	203	87-A30-075-080	0E	C-TR, 2SA1235F	ABC.....
Q	204	87-A30-075-080	0E	C-TR, 2SA1235F	ABC.....
Q	208	87-A30-076-080	0E	C-TR, 2SC3052F	ABC.....
Q	206	87-A30-076-080	0E	C-TR, 2SC3052F	ABC.....
Q	207	87-A30-076-080	0E	C-TR, 2SC3052F	ABC.....
Q	205	87-A30-076-080	0E	C-TR, 2SC3052F	ABC.....
Q	209	87-A30-190-080	0E	TR, CC5551	ABC.....
Q	213	87-A30-076-080	0E	C-TR, 2SC3052F	ABC.....
Q	212	87-A30-076-080	0E	C-TR, 2SC3052F	ABC.....
Q	211	87-A30-076-080	0E	C-TR, 2SC3052F	ABC.....
Q	214	87-A30-076-080	0E	C-TR, 2SC3052F	ABC.....
Q	219	87-A30-106-070	0E	C-TR, CMBT5551	ABC.....
Q	210	87-A30-190-080	0E	TR, CC5551	ABC.....
Q	218	87-A30-214-010	1B	TR, 2SB1344	ABC.....
Q	217	87-A30-214-010	1B	TR, 2SB1344	ABC.....
Q	215	87-A30-215-010	1B	TR, 2SD2025	ABC.....
Q	216	87-A30-215-010	1B	TR, 2SD2025	ABC.....
Q	224	87-A30-105-080	0E	C-TR, RT1P 441C	ABC.....
Q	220	87-A30-106-070	0E	C-TR, CMBT5551	ABC.....
Q	221	87-A30-196-080	0E	TR, 2SC4115SRS	ABC.....
R	56	88-118-153-080	0E	C-RES 15K 1/10W	ABC.....
R	239	87-A00-258-080	0E	RES, M/F 0.22-1W J	ABC.....
R	241	87-A00-258-080	0E	RES, M/F 0.22-1W J	ABC.....
R	244	87-A00-258-080	0E	RES, M/F 0.22-1W J	ABC.....
R	240	87-A00-258-080	0E	RES, M/F 0.22-1W J	ABC.....
R	243	87-A00-258-080	0E	RES, M/F 0.22-1W J	ABC.....
R	242	87-A00-258-080	0E	RES, M/F 0.22-1W J	ABC.....

SCHEMATIC DIAGRAM - 1 (MAIN) <MX-LM700/99>

MAIN AMP ASS'Y

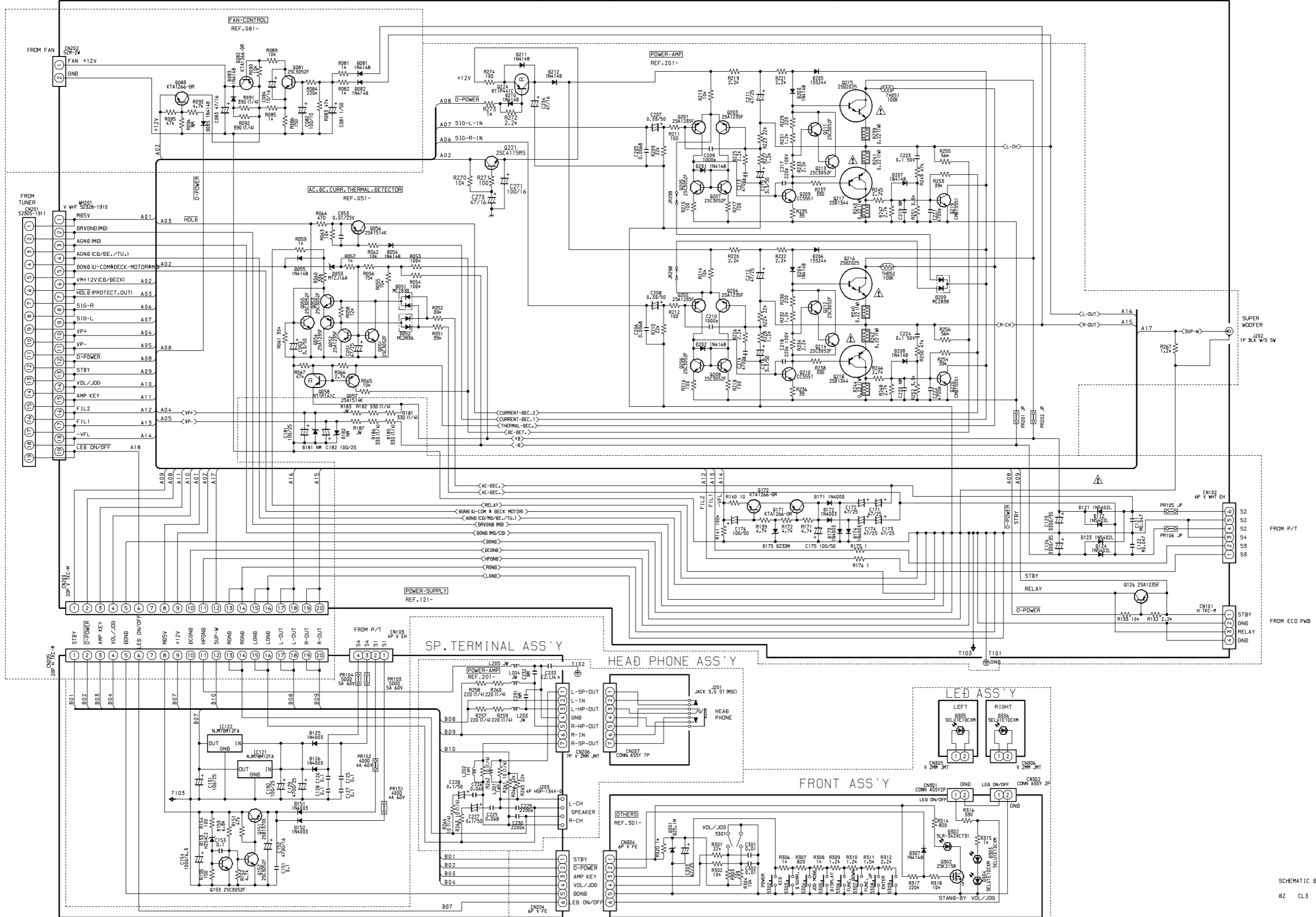

99/03/13
JINKO
SCHEMATIC DIAGRAM (AMP)
BZ CL3

SCHEMATIC DIAGRAM -2 (PT) <MX-LM700/99>

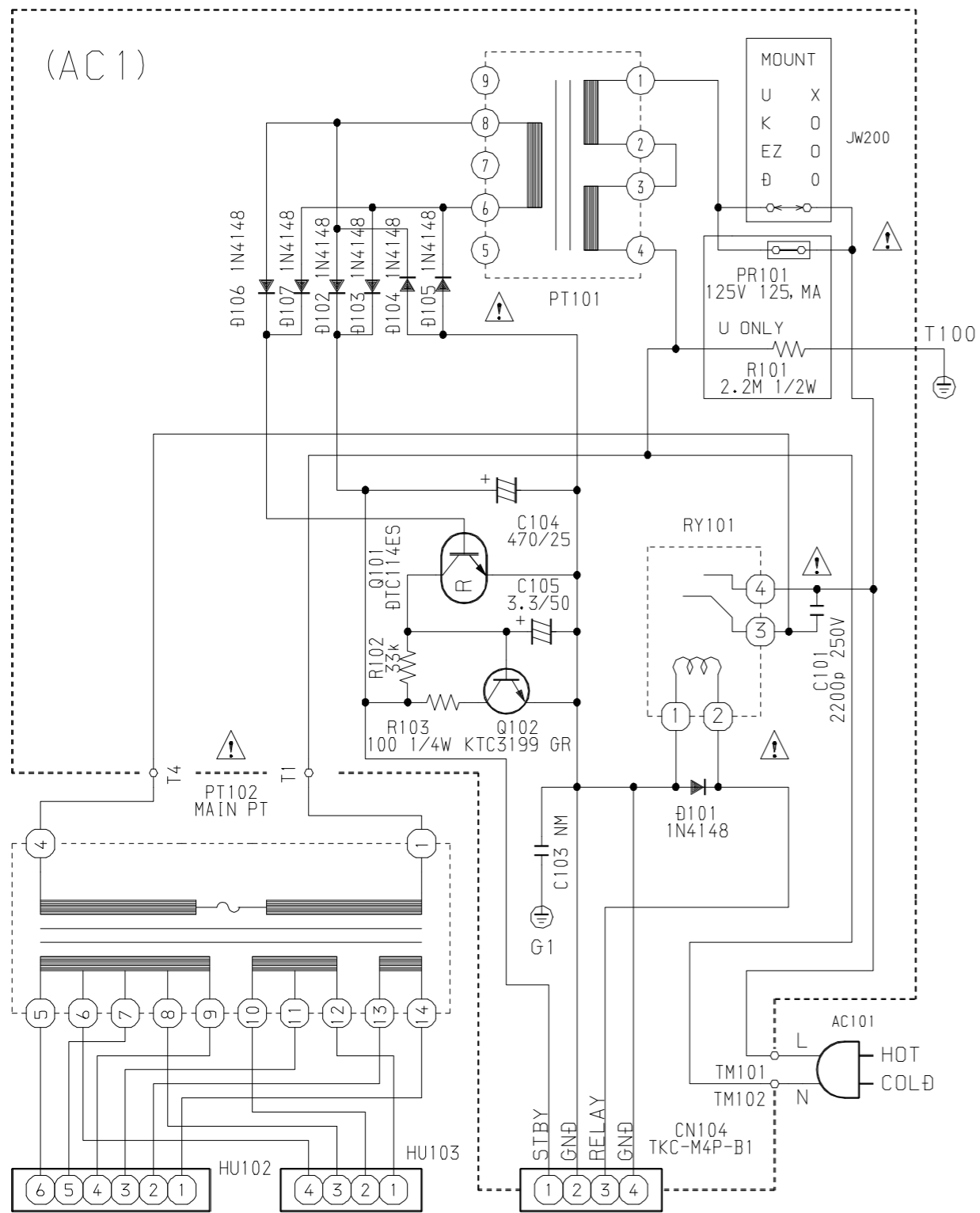

JINKO
99/03/04

PWB, EC1

8Z CL3

MECHANICAL PARTS LIST - 1/1(MX-LM700/99)

NOTE: The characters in the suffix column indicate the part usage.

DOO.....A.....
 LHXX.....B.....
 UXX.....C.....

REF.NO	PARTS NO.	KANRI NO.	DESCRIPTION	SUFFIX
	8Z-CC3-007-010		BADGE,AIWA 27.5 ABS SIL	ABC.....
	8Z-CE3-001-010		CABI,FR AMP	A.....
	8Z-CE3-002-010		PANEL,SIDE L HIGH	AB.....
	8Z-CE3-003-010		PANEL,SIDE R HIGH	AB.....
	8Z-CE3-004-010		PANEL,REAR AMP	A.....
	8Z-CE3-005-010		PANEL, TOP	AB.....
	8Z-CE3-006-010		FOOT,DIA40 H4	ABC.....
	8Z-CE3-007-010		REFLECTOR,FR	ABC.....
	8Z-CE3-008-010		REFLECTOR, JOG	ABC.....
	8Z-CE3-009-010		REFLECTOR, POWER	ABC.....
	8Z-CE3-014-010		COVER, FAN	ABC.....
	8Z-CE3-015-010		CABI,FR AMP (U)	..C.....
	8Z-CE3-016-010		PANEL,SIDE L HIGH (U)	..C.....
	8Z-CE3-017-010		PANEL,SIDE R HIGH (U)	..C.....
	8Z-CE3-018-010		PANEL, TOP (U)	..C.....
	8Z-CE3-019-010		PANEL,REAR AMP (U)	..C.....
	8Z-CE3-022-010		CABI,FR AMP (EZ)	.B.....
	8Z-CE3-025-010		PANEL,REAR AMP (LH)	.B.....
	8Z-CE3-010-010		KEY, POWER	ABC.....
	8Z-CE3-011-010		KEY, FUN	ABC.....
	8Z-CE3-012-010		KEY, ENTER	ABC.....
	8Z-CE3-013-010		KNOB, RTRY JOG	ABC.....
	8Z-CE3-202-010		GUIDE, LED CNT	ABC.....
	8Z-CE3-205-010		HLDR, PWB ECO	ABC.....
	8Z-CE3-207-010		PLATE, JOG	ABC.....
	8Z-CE3-208-010		PLATE, TOP AMP	ABC.....
	87-067-581-010	0E	TAPPING SCREW, BVT2+3-15	ABC.....
	87-067-586-010	0E	TAPPING SCREW, BVT2+4-8	ABC.....
	87-067-689-010	0E	TAPPING SCREW, BVTT+3-8	ABC.....
	87-067-703-010	0E	TAPPING SCREW, BVT2+3-10	ABC.....
	87-078-060-010	0E	BVIT3PB+3-10	ABC.....
	87-591-095-410	0E	TAPPING SCREW, QIT+3-8 (GLD)	ABC.....
	87-B10-230-010	0E	BVT2+3-10 W/O SLOT SILVER CR	ABC.....
	87-NF4-224-010	0E	S-SCREW, IT3B+3-8 CU	ABC.....
	88-AR1-217-010	0E	S-SCREW, BFT2+3-8	ABC.....
	85-XS3-604-010	2M	FAN, MF40D-12	A.C.....
	87-050-098-010	1B	AC CODE ASSY, D	A.....
	87-085-184-010	0E	BUSHING, AC CORD (D)	A.....
	87-085-185-010	0E	BUSHING, AC CORD (E)	.B.....
	87-085-189-010	0E	BUSHING, CORD (U)	..C.....
	87-A80-092-010	1C	AC CORD ASSY, E BLK SUN FAI	.B.....
	87-A80-110-010	1B	AC CORD ASSY, U SPT-2W	..C.....
	87-A90-193-010	0E	HLDR, CV100 (B)	.B.....
	87-A91-438-010		BUSHING, CABLE19P-1.5 SMK	ABC.....
	88-906-121-110	0E	FF-CABLE, 6P	ABC.....
	8Z-CE3-611-010		PT, D SEOUL	A.....
	8Z-CE3-612-010		PT, U	..C.....
	8Z-CE3-614-010		PT, H	.B.....
	8Z-CL1-663-010	2M	FAN, MF40D-12-200MM	.B.....
*	8Z-CE3-203-010		GUIDE, LED L	ABC.....
*	8Z-CE3-204-010		GUIDE, LED R	ABC.....

ELECTRICAL MAIN PARTS LIST - 1/2(TX-LM700/99)

NOTE: The characters in the suffix column indicate the part usage.

DOO.....A.....
 LHXX.....B.....
 UXX.....C.....

REF.NO	PARTS NO.	KANRI NO.	DESCRIPTION	SUFFIX
C	505	87-010-156-080	0E C-CAP,S 15P-50 SL	ABC.....
C	504	87-010-196-080	0E CHIP CAPACITOR,0.1-25	ABC.....
C	502	87-010-196-080	0E CHIP CAPACITOR,0.1-25	ABC.....
C	507	87-010-196-080	0E CHIP CAPACITOR,0.1-25	ABC.....
C	503	87-010-196-080	0E CHIP CAPACITOR,0.1-25	ABC.....
C	506	87-010-198-080	0E CAP, CHIP 0.022	ABC.....
C	501	87-010-408-080	0E CAP, ELECT 47-50V	ABC.....
C	508	87-012-145-080	0E CAP, CHIP S 270P CH	ABC.....
C	511	87-010-194-080	0E CAP, CHIP 0.047	ABC.....
C	512	87-010-194-080	0E CAP, CHIP 0.047	ABC.....
C	515	87-010-196-080	0E CHIP CAPACITOR,0.1-25	ABC.....
C	517	87-010-196-080	0E CHIP CAPACITOR,0.1-25	ABC.....
C	518	87-010-196-080	0E CHIP CAPACITOR,0.1-25	ABC.....
C	513	87-010-375-080	0E CAP,E 330-10 SME	ABC.....
C	510	87-010-378-080	0E CAP, ELECT 10-16V	ABC.....
C	514	87-010-400-040	0E CAP,E 0.47-50	ABC.....
C	516	87-A10-189-040	0E CAP,E 220-10	ABC.....
C	550	87-010-196-080	0E CHIP CAPACITOR,0.1-25	ABC.....
C	553	87-010-404-080	0E CAP, ELECT 4.7-50V	ABC.....
C	551	87-010-404-080	0E CAP, ELECT 4.7-50V	ABC.....
D	509	87-070-274-080	0E DIODE,1N4003 SEM	ABC.....
D	501	87-A40-269-080	0E C-DIODE,MC2836	ABC.....
D	506	87-A40-269-080	0E C-DIODE,MC2836	ABC.....
D	503	87-A40-270-080	0E C-DIODE,MC2838	ABC.....
D	508	87-A40-270-080	0E C-DIODE,MC2838	ABC.....
D	504	87-A40-270-080	0E C-DIODE,MC2838	ABC.....
D	507	87-A40-270-080	0E C-DIODE,MC2838	ABC.....
D	510	87-A40-291-080	0E DIODE,1N4148 (CPT)	ABC.....
D	511	87-A40-509-080	0E ZENER,MTZJ6.8C	ABC.....
IC	51	8Z-CF3-608-010	IC,LC876564-****	ABC.....
L	501	87-A50-052-010	0E COIL,CLOCK 5.76MHZ T1	ABC.....
Q	508	87-026-610-080	0E TR,KTC3198GR	ABC.....
Q	501	87-A30-076-080	0E C-TR,2SC3052F	ABC.....
Q	509	87-A30-087-080	0E C-FET,2SK2158	ABC.....
Q	502	87-A30-087-080	0E C-FET,2SK2158	ABC.....
Q	503	87-A30-087-080	0E C-FET,2SK2158	ABC.....
Q	504	87-A30-087-080	0E C-FET,2SK2158	ABC.....
Q	507	89-327-143-080	0E TR,2SC2714 (0.1W)	ABC.....
Q	505	89-327-143-080	0E TR,2SC2714 (0.1W)	ABC.....
Q	506	89-327-143-080	0E TR,2SC2714 (0.1W)	ABC.....
*		8Z-CE3-203-010	GUIDE,LED L	ABC.....
*		8Z-CE3-204-010	GUIDE,LED R	ABC.....
*		8Z-CF3-202-010	GUIDE,FL	ABC.....
C	701	87-010-178-080	0E CHIP CAP 1000P	ABC.....
C	702	87-010-405-080	0E CAP, ELECT 10-50V	ABC.....
CN	701	87-A60-041-010	CONN,30P V 9604S-30C	ABC.....
CN	702	87-A60-050-010	CONN,20P V 9604S-20C	ABC.....
CN	709	87-A60-619-010	0E CONN,2P V 2MM JMT	ABC.....
CN	708	87-A60-619-010	0E CONN,2P V 2MM JMT	ABC.....
CN	707	88-805-020-790	CONN ASSY,2P 70MM	ABC.....
CN	706	88-805-021-590	CONN ASSY,2P	ABC.....
CN	710	87-A60-059-010	0E CONN,08P V 9604S-08C	ABC.....
D	704	87-A40-291-080	0E DIODE,1N4148 (CPT)	ABC.....
D	702	87-A40-291-080	0E DIODE,1N4148 (CPT)	ABC.....
D	711	87-A40-640-010	1E LED,SELU1E10CXM BLUE-EF	ABC.....
D	710	87-A40-640-010	1E LED,SELU1E10CXM BLUE-EF	ABC.....
FL	701	8Z-CL4-621-010	2M FL,13-ST-36GNK	ABC.....
IC	701	87-070-246-010	1D IC,GPIU271X	ABC.....
S	707	87-A90-696-080	0E SW,TACT TS2103-03-430	ABC.....
S	706	87-A90-696-080	0E SW,TACT TS2103-03-430	ABC.....
S	705	87-A90-696-080	0E SW,TACT TS2103-03-430	ABC.....
S	702	87-A90-696-080	0E SW,TACT TS2103-03-430	ABC.....
S	701	87-A90-696-080	0E SW,TACT TS2103-03-430	ABC.....
S	704	87-A90-696-080	0E SW,TACT TS2103-03-430	ABC.....
S	703	87-A90-696-080	0E SW,TACT TS2103-03-430	ABC.....
C	307	87-010-187-080	0E CAP CHIP S5600P	ABC.....
C	306	87-010-187-080	0E CAP CHIP S5600P	ABC.....
C	311	87-010-182-080	0E C-CAP,S 2200P-50 B	ABC.....
C	310	87-010-182-080	0E C-CAP,S 2200P-50 B	ABC.....
C	313	87-010-213-080	0E C-CAP,S 0.015-50 B	ABC.....
C	312	87-010-213-080	0E C-CAP,S 0.015-50 B	ABC.....
C	314	87-010-400-080	0E CAP, ELECT 0.47-50V	ABC.....
C	317	87-010-400-080	0E CAP, ELECT 0.47-50V	ABC.....
C	316	87-010-400-080	0E CAP, ELECT 0.47-50V	ABC.....
C	315	87-010-400-080	0E CAP, ELECT 0.47-50V	ABC.....
C	322	87-010-154-080	0E CAP CHIP 10P	ABC.....
C	321	87-010-374-080	0E CAP, ELECT 47-10V	ABC.....
C	320	87-010-374-080	0E CAP, ELECT 47-10V	ABC.....
D	301	87-A40-293-080	0E ZENER,DZ2.7M	ABC.....
D	302	87-A40-293-080	0E ZENER,DZ2.7M	ABC.....
IC	32	87-A21-111-040	1C C-IC,M62495FP	ABC.....
C	209	87-010-188-080	0E CAP,CHIP 6800P	ABC.....
C	204	87-010-196-080	0E CHIP CAPACITOR,0.1-25	ABC.....
C	206	87-010-404-080	0E CAP, ELECT 4.7-50V	ABC.....

ELECTRICAL MAIN PARTS LIST - 2/2(TX-LM700/99)

C	205	87-010-404-080	0E	CAP, ELECT 4.7-50V	ABC.....
C	208	87-010-404-080	0E	CAP, ELECT 4.7-50V	ABC.....
C	207	87-010-404-080	0E	CAP, ELECT 4.7-50V	ABC.....
C	214	87-010-178-080	0E	CHIP CAP 1000P	ABC.....
C	213	87-010-178-080	0E	CHIP CAP 1000P	ABC.....
C	210	87-010-188-080	0E	CAP,CHIP 6800P	ABC.....
C	217	87-010-195-080	0E	C-CAP,S 0.068-25 F	ABC.....
C	218	87-010-195-080	0E	C-CAP,S 0.068-25 F	ABC.....
C	215	87-010-197-080	0E	CAP, CHIP 0.01 DM	ABC.....
C	216	87-010-197-080	0E	CAP, CHIP 0.01 DM	ABC.....
C	219	87-010-401-080	0E	CAP, ELECT 1-50V	ABC.....
C	211	87-012-140-080	0E	CAP 470P	ABC.....
C	212	87-012-140-080	0E	CAP 470P	ABC.....
C	220	87-010-401-080	0E	CAP, ELECT 1-50V	ABC.....
C	223	87-010-404-080	0E	CAP, ELECT 4.7-50V	ABC.....
C	222	87-010-404-080	0E	CAP, ELECT 4.7-50V	ABC.....
C	221	87-010-408-080	0E	CAP, ELECT 47-50V	ABC.....
C	234	87-010-408-080	0E	CAP, ELECT 47-50V	ABC.....
D	207	87-A40-291-080	0E	DIODE,1N4148 (CPT)	ABC.....
D	206	87-A40-291-080	0E	DIODE,1N4148 (CPT)	ABC.....
D	205	87-A40-291-080	0E	DIODE,1N4148 (CPT)	ABC.....
IC	21	87-A21-022-040	1D	C-IC,BA3880FS	ABC.....
Q	205	87-A30-071-080	0E	C-TR,RT1N 144C	ABC.....
Q	204	87-A30-071-080	0E	C-TR,RT1N 144C	ABC.....
Q	225	87-010-196-080	0E	CHIP CAPACITOR,0.1-25	ABC.....
Q	227	87-010-197-080	0E	CAP, CHIP 0.01 DM	ABC.....
Q	228	87-010-197-080	0E	CAP, CHIP 0.01 DM	ABC.....
Q	224	87-010-384-080	0E	CAP, ELECT 100-25V	ABC.....
Q	229	87-010-402-080	0E	CAP, ELECT 2.2-50V	ABC.....
Q	226	87-010-408-080	0E	CAP, ELECT 47-50V	ABC.....
Q	233	87-010-402-080	0E	CAP, ELECT 2.2-50V	ABC.....
Q	230	87-010-405-080	0E	CAP, ELECT 10-50V	ABC.....
Q	231	87-010-405-080	0E	CAP, ELECT 10-50V	ABC.....
IC	22	87-A21-103-040	1E	C-IC,MM1454XFBE	ABC.....
C	201	87-010-112-080	0E	CAP, ELECT 100-16V	ABC.....
C	202	87-010-235-080	0E	CAP,E 470-16 SME	ABC.....
C	235	87-010-237-080	1A	CAP, ELECT 1000-16V	ABC.....
C	232	87-016-268-080		CAP,E 22-10 M BP SME	ABC.....
C	304	87-010-196-080	0E	CHIP CAPACITOR,0.1-25	ABC.....
C	303	87-010-196-080	0E	CHIP CAPACITOR,0.1-25	ABC.....
C	301	87-010-401-080	0E	CAP, ELECT 1-50V	ABC.....
C	302	87-010-401-080	0E	CAP, ELECT 1-50V	ABC.....
C	358	87-010-197-080	0E	CAP, CHIP 0.01 DM	ABC.....
C	357	87-010-401-080	0E	CAP, ELECT 1-50V	ABC.....
C	356	87-010-401-080	0E	CAP, ELECT 1-50V	ABC.....
C	353	87-010-404-080	0E	CAP, ELECT 4.7-50V	ABC.....
C	352	87-010-404-080	0E	CAP, ELECT 4.7-50V	ABC.....
C	351	87-010-407-080	0E	CAP, ELECT 33-50V	ABC.....
C	350	87-010-407-080	0E	CAP, ELECT 33-50V	ABC.....
C	401	87-010-196-080	0E	CHIP CAPACITOR,0.1-25	ABC.....
C	403	87-010-322-080	0E	C-CAP,S 100P-50 CH	ABC.....
C	402	87-010-380-080	0E	CAP, ELECT 47-16V	ABC.....
C	519	87-010-196-080	0E	CHIP CAPACITOR,0.1-25	ABC.....
C	522	87-010-400-080	0E	CAP, ELECT 0.47-50V	ABC.....
C	521	87-010-402-080	0E	CAP, ELECT 2.2-50V	ABC.....
CN	205	87-099-545-010	1A	CONN,14P TKC-M14P-B1	ABC.....
CN	207	87-A60-041-010		CONN,30P V 9604S-30C	ABC.....
CN	206	87-A60-050-010		CONN,20P V 9604S-20C	ABC.....
CN	208	87-A60-059-010	0E	CONN,08P V 9604S-08C	ABC.....
CN	204	87-A61-025-010		CONN,4P TKC-M4P-B1	ABC.....
CN	203	87-A61-042-010		CONN,19P H BLK 52641-1911	ABC.....
CN	201	87-A61-043-010		CONN,20P H BLK 52641-2011	ABC.....
CN	202	87-A61-044-010		CONN,19P H BLUE 52641-1914	ABC.....
CN	704	87-099-570-010	1A	CONN,13P TUC-P13P-B1	ABC.....
CN	703	87-A61-024-010		CONN,4P H BLK TKC-M	ABC.....
D	304	87-001-731-080	0E	ZENER,HZS6C2L	ABC.....
D	303	87-A40-291-080	0E	DIODE,1N4148 (CPT)	ABC.....
D	513	87-A40-291-080	0E	DIODE,1N4148 (CPT)	ABC.....
D	512	87-A40-291-080	0E	DIODE,1N4148 (CPT)	ABC.....
IC	31	87-020-877-010	1B	IC,LC4966	ABC.....
IC	401	87-017-915-080	1B	IC,BU4094BCF	ABC.....
J	701	87-A60-354-010	1B	JACK,PIN 2P MSP -242V-05	ABC.....
Q	207	87-A30-072-080	0E	C-TR,RT1P 144C	ABC.....
Q	206	87-A30-072-080	0E	C-TR,RT1P 144C	ABC.....
Q	203	87-A30-073-080	0E	C-TR,RT1N 141C	ABC.....
Q	201	87-A30-196-080	0E	TR,2SC4115SRS	ABC.....
Q	306	87-026-297-080	0E	TR,DTA144TK	ABC.....
Q	309	87-026-609-080	0E	TR,KTA1266GR	ABC.....
Q	304	87-A30-047-080	0E	TR,CSD655E	ABC.....
Q	308	87-A30-047-080	0E	TR,CSD655E	ABC.....
Q	307	87-A30-047-080	0E	TR,CSD655E	ABC.....
Q	305	87-A30-047-080	0E	TR,CSD655E	ABC.....
Q	302	87-A30-072-080	0E	C-TR,RT1P 144C	ABC.....
Q	303	87-A30-073-080	0E	C-TR,RT1N 141C	ABC.....
Q	301	87-A30-073-080	0E	C-TR,RT1N 141C	ABC.....
Q	512	87-026-610-080	0E	TR,KTC3198GR	ABC.....
Q	511	87-026-610-080	0E	TR,KTC3198GR	ABC.....
Q	510	87-026-610-080	0E	TR,KTC3198GR	ABC.....

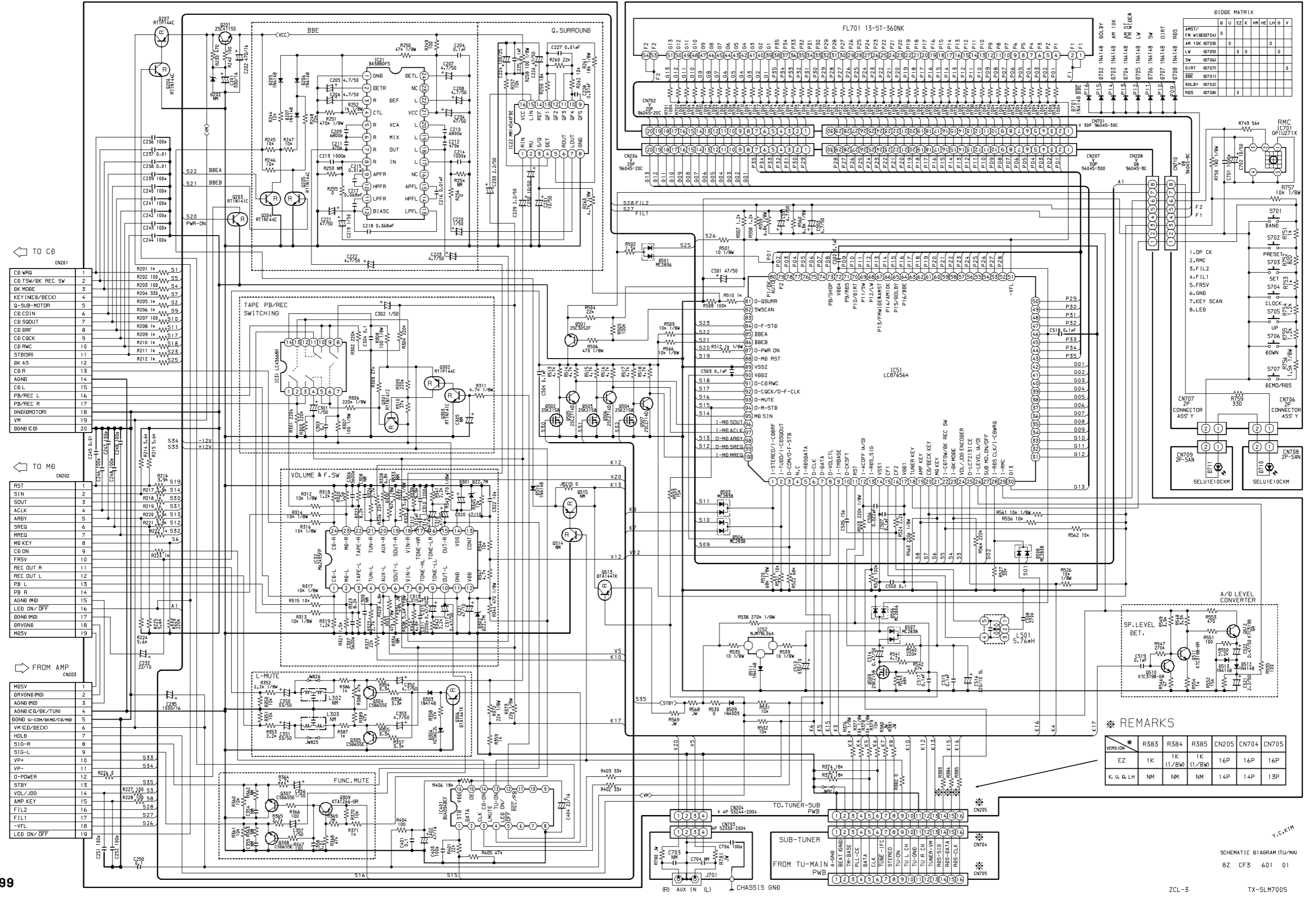

REMARKS

VERSION	R383	R384	R385	CN205	CN704	CN705
EZ	1K	1K (1/2W)	1K (1/2W)	16P	16P	16P
K, U, D, LH	NM	NM	NM	14P	14P	13P

MECHANICAL PARTS LIST - 1/1(TX-LM700/99)

NOTE: The characters in the suffix column indicate the part usage.

REF.NO	PARTS NO.	KANRI NO.	DESCRIPTION	SUFFIX
D	OO			A
LH	XX			B
U	XX			C
8Z-CC3-007-010			BADGE,AIWA 27.5 ABS SIL	ABC
8Z-CE3-005-010			PANEL, TOP	AB
8Z-CE3-006-010			FOOT, DIA40 H4	ABC
8Z-CE3-007-010			REFLECTOR, FR	ABC
8Z-CE3-018-010			PANEL, TOP (U)	.C
8Z-CF3-001-010			CABI, FR TUNER	AB
8Z-CF3-002-010			PANEL, SIDE L LOW	AB
8Z-CF3-003-010			PANEL, SIDE R LOW	AB
8Z-CF3-004-010			PANEL, REAR TUNER (H)	.B
8Z-CF3-005-010			WINDOW, DISPLAY	ABC
8Z-CF3-006-010			WINDOW, SENSOR	ABC
8Z-CF3-011-010			CABI, FR TUNER (U)	.C
8Z-CF3-012-010			PANEL, SIDE L LOW (U)	.C
8Z-CF3-013-010			PANEL, SIDE R LOW (U)	.C
8Z-CF3-014-010			PANEL, REAR TUNER (U)	.C
8Z-CF3-016-010			PANEL, REAR TUNER (D)	A
8Z-CF3-007-010			KEY, DEMO	ABC
8Z-CF3-008-010			KEY, TUNER	ABC
8Z-CE3-202-010			GUIDE, LED CNT	ABC
8Z-CF3-203-010			PLATE, TOP TUNER	ABC
87-067-660-010	0E		TAPPING SCREW, BVT2+3-8	.B
87-067-689-010	0E		TAPPING SCREW, BVTT+3-8	A.C
87-067-703-010	0E		TAPPING SCREW, BVT2+3-10	ABC
87-067-761-010	0E		TAPPING SCREW, BVT2+3-10	ABC
87-078-060-010	0E		BVIT3PB+3-10	ABC
87-721-096-410	0E		QT2+3-10 GLD	ABC
87-B10-230-010	0E		BVT2+3-10 W/O SLOT SILVER CR	A.C
88-908-151-110	0E		FF-CABLE, 8P 1.25-150MM	ABC
88-920-151-110			FF-CABLE, 20P 1.25	ABC
88-930-151-110			FF-CABLE, 30P 1.25	ABC

*

ELECTRICAL MAIN PARTS LIST - 1/2(DX-LM700/99)

NOTE: The characters in the suffix column indicate the part usage.

DOO.....A.....
 LHXX.....B.....
 UXX.....C.....

REF.NO	PARTS NO.	KANRI NO.	DESCRIPTION	SUFFIX
C	95	87-010-197-080	OE CAP, CHIP 0.01 DM	ABC.....
C	92	87-010-382-080	OE CAP, ELECT 22-25V	ABC.....
C	91	87-010-408-080	OE CAP, ELECT 47-50V	ABC.....
Q	92	87-A30-047-080	OE TR,CSD655E	ABC.....
Q	93	87-A30-047-080	OE TR,CSD655E	ABC.....
Q	91	87-A30-047-080	OE TR,CSD655E	ABC.....
Q	94	87-A30-047-080	OE TR,CSD655E	ABC.....
C	2	87-010-197-080	OE CAP, CHIP 0.01 DM	ABC.....
C	5	87-010-197-080	OE CAP, CHIP 0.01 DM	ABC.....
C	8	87-010-198-080	OE CAP, CHIP 0.022	ABC.....
C	4	87-010-248-080	OE CAP, ELECT 220-10V	ABC.....
C	9	87-010-248-080	OE CAP, ELECT 220-10V	ABC.....
C	3	87-010-263-080	OE CAP, ELECT 100-10V	ABC.....
C	6	87-010-374-080	OE CAP, ELECT 47-10V	ABC.....
C	1	87-010-403-080	OE CAP, ELECT 3.3-50V	ABC.....
C	7	87-012-349-080	OE C-CAP,S 1000P-50 CH	ABC.....
C	13	87-010-193-080	OE CHIP CAPACITOR,0.033	ABC.....
C	18	87-010-213-080	OE C-CAP,S 0.015-50 B	ABC.....
C	10	87-010-263-080	OE CAP, ELECT 100-10V	ABC.....
C	12	87-010-401-080	OE CAP, ELECT 1-50V	ABC.....
C	14	87-010-405-080	OE CAP, ELECT 10-50V	ABC.....
C	16	87-010-545-080	OE CAP, ELECT 0.22-50V	ABC.....
C	17	87-012-157-080	OE C-CAP,S 330P-50 CH	ABC.....
C	22	87-010-183-080	OE C-CAP,S 2700P-50 B	ABC.....
C	29	87-010-186-080	OE CAP,CHIP 4700P	ABC.....
C	20	87-010-193-080	OE CHIP CAPACITOR,0.033	ABC.....
C	28	87-010-197-080	OE CAP, CHIP 0.01 DM	ABC.....
C	23	87-010-956-080	OE CHIP-CAP,S 0.068-25B	ABC.....
C	25	87-010-994-080	OE C-CAP,S 680P-50 CH	ABC.....
C	34	87-010-184-080	OE CHIP CAPACITOR 3300P(K)	ABC.....
C	38	87-010-196-080	OE CHIP CAPACITOR,0.1-25	ABC.....
C	35	87-010-197-080	OE CAP, CHIP 0.01 DM	ABC.....
C	32	87-010-374-080	OE CAP, ELECT 47-10V	ABC.....
C	36	87-010-374-080	OE CAP, ELECT 47-10V	ABC.....
C	33	87-010-401-080	OE CAP, ELECT 1-50V	ABC.....
C	37	87-010-404-080	OE CAP, ELECT 4.7-50V	ABC.....
C	31	87-010-545-080	OE CAP, ELECT 0.22-50V	ABC.....
C	30	87-012-156-080	OE C-CAP,S 220P-50 CH	ABC.....
C	39	87-012-349-080	OE C-CAP,S 1000P-50 CH	ABC.....
C	40	87-010-145-080	OE C-CAP,S 1P-50 CH	ABC.....
C	45	87-010-196-080	OE CHIP CAPACITOR,0.1-25	ABC.....
C	47	87-010-196-080	OE CHIP CAPACITOR,0.1-25	ABC.....
C	46	87-010-196-080	OE CHIP CAPACITOR,0.1-25	ABC.....
C	42	87-010-314-080	OE C-CAP,S 22P-50V	ABC.....
C	48	87-010-315-080	OE C-CAP,S 27P-50 CH	ABC.....
C	55	87-010-263-080	OE CAP, ELECT 100-10V	ABC.....
C	59	87-010-263-080	OE CAP, ELECT 100-10V	ABC.....
C	58	87-010-316-080	OE C-CAP,S 33P-50 CH	ABC.....
C	57	87-010-316-080	OE C-CAP,S 33P-50 CH	ABC.....
C	53	87-010-322-080	OE C-CAP,S 100P-50 CH	AB.....
C	50	87-012-140-080	OE CAP 470P	ABC.....
C	52	87-012-140-080	OE CAP 470P	AB.....
C	54	87-012-153-080	OE C-CAP,S 120P-50 CH	AB.....
C	51	87-012-156-080	OE C-CAP,S 220P-50 CH	ABC.....
C	60	87-010-196-080	OE CHIP CAPACITOR,0.1-25	ABC.....
C	66	87-010-196-080	OE CHIP CAPACITOR,0.1-25	ABC.....
C	61	87-010-196-080	OE CHIP CAPACITOR,0.1-25	ABC.....
C	67	87-010-263-080	OE CAP, ELECT 100-10V	ABC.....
C	65	87-010-404-080	OE CAP, ELECT 4.7-50V	ABC.....
C	69	87-012-154-080	OE C-CAP,S 150P-50 CH	ABC.....
C	62	87-A10-373-080	OE CAP,E 220-6.3 M SSL	ABC.....
C	77	87-010-197-080	OE CAP, CHIP 0.01 DM	ABC.....
C	75	87-010-197-080	OE CAP, CHIP 0.01 DM	ABC.....
C	78	87-010-221-080	OE CAP, ELECT 470-10V	ABC.....
C	79	87-010-263-080	OE CAP, ELECT 100-10V	ABC.....
C	76	87-A10-102-080	OE CAP,E 1000-10 REA	ABC.....
C	83	87-010-181-080	OE CAP,CHIP S 1800P	ABC.....
C	84	87-010-181-080	OE CAP,CHIP S 1800P	ABC.....
C	80	87-010-197-080	OE CAP, CHIP 0.01 DM	ABC.....
C	81	87-010-405-080	OE CAP, ELECT 10-50V	ABC.....
C	82	87-010-405-080	OE CAP, ELECT 10-50V	ABC.....
C	90	87-010-196-080	OE CHIP CAPACITOR,0.1-25	ABC.....
C	94	87-010-197-080	OE CAP, CHIP 0.01 DM	ABC.....
C	93	87-010-197-080	OE CAP, CHIP 0.01 DM	ABC.....
C	110	87-010-196-080	OE CHIP CAPACITOR,0.1-25	ABC.....
D	1	87-A40-291-080	OE DIODE,1N4148 (CPT)	ABC.....
D	2	87-A40-291-080	OE DIODE,1N4148 (CPT)	ABC.....
D	3	87-A40-291-080	OE DIODE,1N4148 (CPT)	ABC.....
IC	3	87-A20-445-010	1F IC,BA5936	ABC.....
IC	1	87-A20-446-010	1E C-IC,LA9241ML	ABC.....
IC	2	87-A20-459-010	2A C-IC,LC78622ED	ABC.....
L	1	87-003-102-080	OE COIL, 10UH	ABC.....
L	5	87-003-152-080	OE COIL, 100UH	ABC.....
L	4	87-003-152-080	OE COIL, 100UH	AB.....

ELECTRICAL MAIN PARTS LIST - 2/2(DX-LM700/99)

L	3	87-008-372-080	0E	FILTER, EMI BL OIRNI	..C.....
Q	3	87-026-239-080	0E	TR,DTC114TK (0.2W)	ABC.....
Q	1	87-026-463-080	0E	TR,2SA933S (0.3W)	ABC.....
Q	71	88-NF9-637-010		TR,2SA1318T/U	ABC.....
Q	83	87-026-239-080	0E	TR,DTC114TK (0.2W)	ABC.....
Q	84	87-026-239-080	0E	TR,DTC114TK (0.2W)	ABC.....
Q	82	87-026-297-080	0E	TR,DTA144TK	ABC.....
Q	81	87-026-297-080	0E	TR,DTA144TK	ABC.....
R	68	87-A50-189-080	0E	C-COIL,S BLM21B272S	.BC.....
SFR	130	87-024-437-080	0E	SFR100K,RH063EC	ABC.....
X	1	87-A70-046-010	1B	VIB,XTAL 16.934MHZ	ABC.....
*		8Z-CE3-203-010		GUIDE,LED L	ABC.....
*		8Z-CE3-204-010		GUIDE,LED R	ABC.....
C	107	87-010-197-080	0E	CAP,CHIP 0.01 DM	ABC.....
C	101	87-010-322-080	0E	C-CAP,S 100P-50 CH	ABC.....
C	102	87-010-322-080	0E	C-CAP,S 100P-50 CH	ABC.....
C	106	87-010-322-080	0E	C-CAP,S 100P-50 CH	ABC.....
C	105	87-010-322-080	0E	C-CAP,S 100P-50 CH	ABC.....
C	104	87-010-322-080	0E	C-CAP,S 100P-50 CH	ABC.....
C	103	87-010-322-080	0E	C-CAP,S 100P-50 CH	ABC.....
C	109	87-010-322-080	0E	C-CAP,S 100P-50 CH	ABC.....
C	108	87-010-374-080	0E	CAP,ELECT 47-10V	ABC.....
C	111	87-010-197-080	0E	CAP,CHIP 0.01 DM	ABC.....
C	112	87-010-382-080	0E	CAP,ELECT 22-25V	ABC.....
C	113	87-010-382-080	0E	CAP,ELECT 22-25V	ABC.....
C	302	87-010-197-080	0E	CAP,CHIP 0.01 DM	ABC.....
C	301	87-010-374-080	0E	CAP,ELECT 47-10V	ABC.....
CN	2	87-A60-081-010	0E	CONN,06P H 9604S-06F	ABC.....
CN	3	87-A60-082-010	0E	CONN,05P H 9604S-05F	ABC.....
CN	1	87-A60-424-010	0E	CONN,16P V TOC-B	ABC.....
CN	101	87-099-562-010	1A	CONN,18P TUC-P18X-B1	ABC.....
CN	102	87-099-573-010	0E	CONN,18P TUC-P18P-B1	ABC.....
CN	103	87-A60-586-010	0E	CONN,4P V FE	ABC.....
CN	104	87-A61-040-010		CONN,20P V WHT 52328	ABC.....
CN	105	87-A61-041-010		CONN,15P H BLK 52303-1511	ABC.....
CN	202	87-A60-083-010	0E	CONN,04P H 9604S-04F	ABC.....
CN	204	88-805-020-790		CONN ASSY,2P 70MM	ABC.....
CN	203	88-805-020-790		CONN ASSY,2P 70MM	ABC.....
CN	303	87-099-555-010	0E	CONN,7P TUC-P	ABC.....
CN	304	87-099-566-010	0E	CONN,7P TUC-P7P-B1	ABC.....
CN	302	87-A60-619-010	0E	CONN,2P V 2MM JMT	ABC.....
CN	301	87-A60-619-010	0E	CONN,2P V 2MM JMT	ABC.....
D	101	87-017-931-080	0E	ZENER,MTZJ5.6B	ABC.....
D	102	87-A40-291-080	0E	DIODE,1N4148 (CPT)	ABC.....
D	201	87-A40-640-010	1E	LED,SELU1E10CXM BLUE-EF	ABC.....
D	202	87-A40-640-010	1E	LED,SELU1E10CXM BLUE-EF	ABC.....
IC	5	87-017-825-010	1E	IC,GPIF32T	ABC.....
IC	4	87-017-915-080	1B	IC,BU4094BCF	ABC.....
IC	301	87-A21-326-010		IC,TC74HC154AP	ABC.....
Q	102	87-026-213-080	0E	CHIP-TR,DTC114YK	ABC.....
Q	103	87-026-213-080	0E	CHIP-TR,DTC114YK	ABC.....
Q	101	87-026-580-080	0E	C-TR,DTA123JK	ABC.....
Q	306	87-026-233-080	0E	TR,DTA114TK-TP	ABC.....
Q	302	87-026-233-080	0E	TR,DTA114TK-TP	ABC.....
Q	307	87-026-233-080	0E	TR,DTA114TK-TP	ABC.....
Q	309	87-026-233-080	0E	TR,DTA114TK-TP	ABC.....
Q	304	87-026-233-080	0E	TR,DTA114TK-TP	ABC.....
Q	305	87-026-233-080	0E	TR,DTA114TK-TP	ABC.....
Q	303	87-026-233-080	0E	TR,DTA114TK-TP	ABC.....
Q	308	87-026-233-080	0E	TR,DTA114TK-TP	ABC.....
Q	313	87-026-233-080	0E	TR,DTA114TK-TP	ABC.....
Q	312	87-026-233-080	0E	TR,DTA114TK-TP	ABC.....
Q	311	87-026-233-080	0E	TR,DTA114TK-TP	ABC.....
Q	310	87-026-233-080	0E	TR,DTA114TK-TP	ABC.....
S	202	87-A90-696-080	0E	SW,TACT TS2103-03-430	ABC.....
S	200	87-A90-696-080	0E	SW,TACT TS2103-03-430	ABC.....
S	204	87-A90-696-080	0E	SW,TACT TS2103-03-430	ABC.....
S	201	87-A90-696-080	0E	SW,TACT TS2103-03-430	ABC.....
S	203	87-A90-696-080	0E	SW,TACT TS2103-03-430	ABC.....
S	205	87-A90-696-080	0E	SW,TACT TS2103-03-430	ABC.....

SCHEMATIC DIAGRAM - 4 (MAIN) <DX-LM700/99>

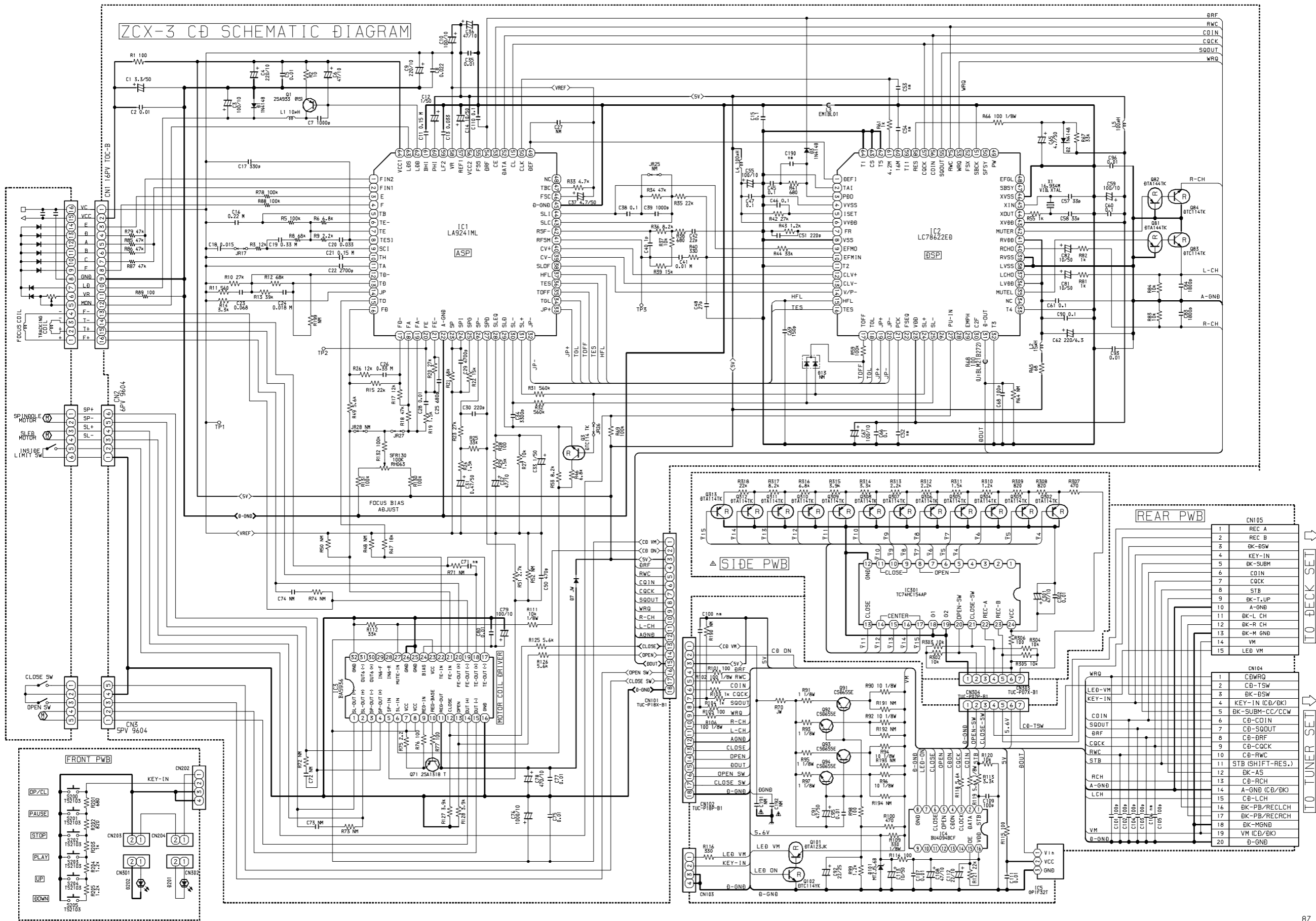

D.C. MUN
CD

82 CX3 601 01

ZCL-3

99 04 26

MECHANICAL PARTS LIST - 1/1(TX-LM700/99)

NOTE: The characters in the suffix column indicate the part usage.

DOO.....A.....
 LHXX.....B.....
 UXX.....C.....

REF.NO	PARTS NO.	KANRI NO.	DESCRIPTION	SUFFIX
	8Z-CC3-007-010		BADGE,AIWA 27.5 ABS SIL	ABC.....
	8Z-CE3-005-010		PANEL, TOP	AB.....
	8Z-CE3-006-010		FOOT, DIA40 H4	ABC.....
	8Z-CE3-007-010		REFLECTOR, FR	ABC.....
	8Z-CE3-018-010		PANEL, TOP (U)	..C.....
	8Z-CX3-001-010		CABI, FR CD	AB.....
	8Z-CX3-002-010		PANEL, REAR CD	A.....
	8Z-CX3-003-010		PANEL, TRAY	ABC.....
	8Z-CX3-004-010		RING, CD	ABC.....
	8Z-CX3-006-010		PANEL, SIDE L HIGH CD	AB.....
	8Z-CX3-007-010		PANEL, SIDE R HIGH CD	AB.....
	8Z-CX3-008-010		CABI, FR CD (U)	..C.....
	8Z-CX3-009-010		PANEL, SIDE L HIGH CD(U)	..C.....
	8Z-CX3-010-010		PANEL, SIDE R HIGH CD(U)	..C.....
	8Z-CX3-011-010		PANEL, REAR CD (U)	..C.....
	8Z-CX3-013-010		PANEL, REAR CD YLHS	.B.....
	8Z-CC3-005-010		KEY, UP DOWN	ABC.....
	8Z-CX3-005-010		KEY, PLAY CD	ABC.....
	8Z-CE3-202-010		GUIDE, LED CNT	ABC.....
	8Z-CX3-202-010		PLATE, TOP CD	ABC.....
	8Z-CX3-204-010		HLDR, PWB CD	.B.....
	87-067-584-010	0E	TAPPING SCREW, BVT2+3-6	.B.....
	87-067-660-010	0E	TAPPING SCREW, BVT2+3-8	.B.....
	87-067-689-010	0E	TAPPING SCREW, BVTT+3-8	A.C.....
	87-067-703-010	0E	TAPPING SCREW, BVT2+3-10	ABC.....
	87-067-761-010	0E	TAPPING SCREW, BVT2+3-10	ABC.....
	87-078-060-010	0E	BVIT3PB+3-10	ABC.....
	87-721-096-410	0E	QT2+3-10 GLD	ABC.....
*	87-B10-230-010	0E	BVT2+3-10 W/O SLOT SILVER CR	A.C.....
	88-904-261-110	0E	FF-CABLE, 4P 1.25 260MM	ABC.....
	88-905-111-110		FF-CABLE, 5P 1.25 110MM	ABC.....
	88-906-321-110		FF-CABLE, 6P 1.25 320MM	ABC.....
	8Z-CX3-607-010		CONN ASSY, 20P 52305-2011	ABC.....
	8Z-CX3-608-010		FF-CABLE, 16P 1.0 320MM	ABC.....

ELECTRICAL MAIN PARTS LIST - 1/1(AM-LM700)

NOTE: The characters in the suffix column indicate the part usage.

REF.NO	PARTS NO.	KANRI NO.	DESCRIPTION	SUFFIX
D		OO		A
LH		XX		B
U		XX		C
*	8Z-CE3-203-010		GUIDE,LED L	AB
*	8Z-CE3-204-010		GUIDE,LED R	AB
CN 905	87-A60-083-010	0E	CONN,04P H 9604S-04F	A
CN 903	87-A60-422-010	0E	CONN,8P V TOC-B	AB
CN 902	87-A60-423-010	0E	CONN,14P V TOC-B	AB
CN 904	87-A60-586-010	0E	CONN,4P V FE	AB
CN 905	87-A60-586-010	0E	CONN,4P V FE	AB
CN 907	87-A60-619-010	0E	CONN,2P V 2MM JMT	AB
CN 906	87-A60-619-010	0E	CONN,2P V 2MM JMT	AB
CN 901	87-A61-039-010		CONN,19P V WHT 52328	AB
CN 909	88-805-020-790		CONN ASSY,2P 70MM	.B
CN 909	88-805-021-090		CONN ASSY,2P	A
CN 908	88-805-021-590		CONN ASSY,2P	AB
D 901	87-A40-640-010	1E	LED,SELU1E10CXM BLUE-EF	AB
D 902	87-A40-640-010	1E	LED,SELU1E10CXM BLUE-EF	AB
S 909	87-A90-696-080	0E	SW,TACT TS2103-03-430	AB
S 905	87-A90-696-080	0E	SW,TACT TS2103-03-430	AB
S 901	87-A90-696-080	0E	SW,TACT TS2103-03-430	AB
S 904	87-A90-696-080	0E	SW,TACT TS2103-03-430	AB
S 908	87-A90-696-080	0E	SW,TACT TS2103-03-430	AB
S 903	87-A90-696-080	0E	SW,TACT TS2103-03-430	AB
S 906	87-A90-696-080	0E	SW,TACT TS2103-03-430	AB
S 907	87-A90-696-080	0E	SW,TACT TS2103-03-430	AB
S 902	87-A90-696-080	0E	SW,TACT TS2103-03-430	AB
S 910	87-A90-696-080	0E	SW,TACT TS2103-03-430	AB
C 903	87-010-178-080	0E	CHIP CAP 1000P	AB
C 906	87-010-178-080	0E	CHIP CAP 1000P	AB
C 907	87-010-196-080	0E	CHIP CAPACITOR,0.1-25	AB
C 901	87-010-196-080	0E	CHIP CAPACITOR,0.1-25	AB
C 904	87-010-196-080	0E	CHIP CAPACITOR,0.1-25	AB
C 902	87-010-374-080	0E	CAP, ELECT 47-10V	AB
C 905	87-010-374-080	0E	CAP, ELECT 47-10V	AB
IC 902	87-A20-625-010	1E	IC,RX178A	AB
IC 901	87-A20-625-010	1E	IC,RX178A	AB
IC 903	87-A21-175-040	1A	C-IC,TC74VHC14FT	AB
Q 904	87-A30-071-080	0E	C-TR,RT1N 144C	AB
Q 905	87-A30-071-080	0E	C-TR,RT1N 144C	AB
Q 903	87-A30-074-080	0E	C-TR,RT1P 141C	AB
Q 906	87-A30-074-080	0E	C-TR,RT1P 141C	AB
Q 901	87-A30-087-080	0E	C-FET,2SK2158	AB
Q 902	87-A30-087-080	0E	C-FET,2SK2158	AB

SCHEMATIC DIAGRAM - 5 (MAIN) <AM-LM700>

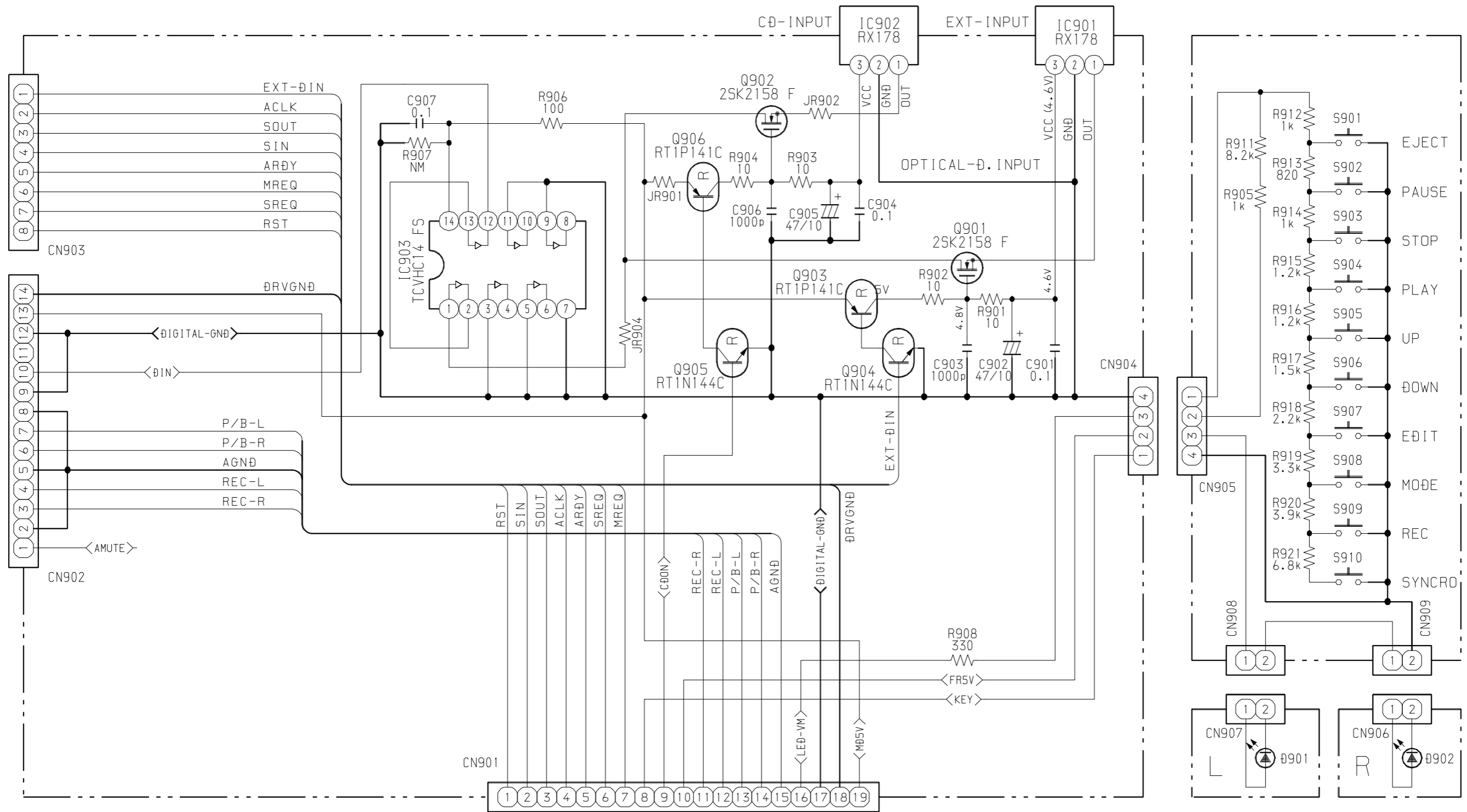

B. D. KIM

MD

8Z CC3 601 01

MECHANICAL PARTS LIST - 1/1(AM-LM700)

NOTE: The characters in the suffix column indicate the part usage.

REF.NO	PARTS NO.	KANRI NO.	DESCRIPTION	SUFFIX
D		OO		A
LH		XX		B
U		XX		C
8Z-CC3-001-010			CABI,FR MD	.B
8Z-CC3-002-010			PANEL,REAR MD	.B
8Z-CC3-003-010			RING,MD	AB
8Z-CC3-006-010			PLATE,DISC	AB
8Z-CC3-007-010			BADGE,AIWA 27.5 ABS SIL	AB
8Z-CC3-008-010			CABI,FR MD (U)	A
8Z-CC3-009-010			PANEL,REAR MD (U)	A
8Z-CC3-010-010			PANEL,REAR MD (Y)	
8Z-CE3-005-010			PANEL, TOP	.B
8Z-CE3-006-010			FOOT,DIA40 H4	AB
8Z-CE3-007-010			REFLECTOR,FR	AB
8Z-CE3-018-010			PANEL, TOP (U)	A
8Z-CF3-002-010			PANEL,SIDE L LOW	.B
8Z-CF3-003-010			PANEL,SIDE R LOW	.B
8Z-CF3-012-010			PANEL,SIDE L LOW (U)	A
8Z-CF3-013-010			PANEL,SIDE R LOW (U)	A
8Z-CC3-004-010			KEY,PLAY MD	AB
8Z-CC3-005-010			KEY,UP DOWN	AB
88-CE2-209-010		0E	SPR-T,MD	AB
8Z-CC3-203-010			CHAS,MAIN MD (U)	A
8Z-CE3-202-010			GUIDE,LED CNT	AB
8Z-CF3-203-010			PLATE, TOP TUNER	AB
* 8Z-CC3-202-010			GUIDE,MD	AB
87-067-689-010		0E	TAPPING SCREW, BVTT+3-8	AB
87-067-703-010		0E	TAPPING SCREW, BVT2+3-10	AB
87-067-761-010		0E	TAPPING SCREW, BVT2+3-10	AB
87-078-060-010		0E	BVIT3PB+3-10	AB
87-721-096-410		0E	QT2+3-10 GLD	AB
* 87-B10-230-010		0E	BVT2+3-10 W/O SLOT SILVER CR	AB
87-A91-438-010			BUSHING,CABLE19P-1.5 SMK	AB
CNA 0 8Z-CC3-606-010			CONN ASSY,19P 52305-1914	AB
W 0 88-904-261-110		0E	FF-CABLE, 4P 1.25 260MM	AB
W 0 8Z-CC3-607-010			FF-CABLE, 14P 1.0 100MM	AB
W 0 8Z-CC3-608-010			FF-CABLE, 8P 1.0 100MM	AB

ACCESSORIES / PACKAGE LIST - 1/1(AM-LM700/99)

NOTE: The characters in the suffix column indicate the part usage.

REF.NO	PARTS NO.	NO.	DESCRIPTION	SUFFIX
D		OO		A
LH		XX		B
U		XX		C
		KANRI		
	8Z-CL3-908-010		IB,D(J)I	A
	8Z-CLP-902-010		IB,LH(ESP)I	.B
	8Z-CLP-903-010		IB,U(ESF)I	.C
	87-A90-312-010		PLUG,CONVERSION WTN-1157R1	.B
	87-B30-024-010	1E	CABLE,OPTICAL MC-901	A
	87-043-115-010	1A	ANT,FEEDER FM	ABC
	87-A90-030-010	1B	ANT,LOOP AM-NC C	ABC
	8Z-CK4-962-010	1H	RC UNIT,RC-ZAT04 (VS)	ABC

サービス技術ニュース	
番号	連絡内容
G- -	
G- -	
G- -	

アイワ株式会社
AIWA CO.,LTD.

9820572

Tokyo Japan

〒110-8710 東京都台東区池之端1-2-11 ☎03(3827)3111 (代表)

Printed in Singapore