

aiwa



XR-MT1000

STEREO SYSTEM

- BASIC TAPE MECHANISM: 2ZM-3MK2 YPR4N
- BASIC CD MECHANISM: 4ZG-1 Z3DSHNM
- TYPE: U

SIMPLE MANUAL

AMPLIFIER	CASSETTE DECK	GRAPHIC EQUALIZER	CD PLAYER	SPEAKERS	REMOTE CONTROL
MX-NMT1000	FX-NM1000	GE-NMT1000	DX-NM1000	SX-NMT1000 SX-R275 SX-C605	RC-7AS09

- Replace this Service Manual with "Revision Publishing" when it is issued.
- If requiring information about the CD mechanism, see Service Manual of 4ZG-1, S/M Code No. 09-983-249-30T.

MANUAL
SERVICE

ELECTRICAL MAIN PARTS LIST - 1/8 (MX-NMT1000)

NOTE: The characters in the suffix column indicate the part usage.

REF.NO	PARTS NO.	DESCRIPTION	SUFFIX	
UXX	A.....	
C	209	87-010-071-040	CAP,E 1-50 5L	A.....
C	201	87-010-192-080	C-CAP,S 0.022-50 F	A.....
C	207	87-010-194-080	CAP, CHIP 0.047	A.....
C	205	87-010-194-080	CAP, CHIP 0.047	A.....
C	202	87-010-264-040	CAP,E 100-10 5L	A.....
C	206	87-010-405-040	CAP,E 10-50	A.....
C	203	87-010-490-040	CAP, ELECT 0.1-50	A.....
C	208	87-A10-189-040	CAP,E 220-10	A.....
C	204	87-A10-586-040	CAP,E 47-35 7L SR	A.....
C	211	87-012-140-080	CAP 470P	A.....
C	222	87-010-401-040	CAP,E 1-50 SME	A.....
C	220	87-016-669-080	C-CAP,S 0.1-25 K B	A.....
C	221	87-016-669-080	C-CAP,S 0.1-25 K B	A.....
C	241	87-010-178-080	CHIP CAP 1000P	A.....
C	248	87-010-192-080	C-CAP,S 0.022-50 F	A.....
C	243	87-010-312-080	C-CAP,S 15P-50 CH	A.....
C	244	87-010-316-080	C-CAP,S 33P-50 CH	A.....
C	242	87-010-318-080	C-CAP,S 47P-50 CH	A.....
C	247	87-016-669-080	C-CAP,S 0.1-25 K B	A.....
D	201	87-017-931-080	ZENER,MTZJ5.6B	A.....
D	202	87-A40-468-080	C-DIODE,HSM2836CTR	A.....
D	205	87-A40-470-080	DIODE,1SS254	A.....
D	203	87-A40-470-080	DIODE,1SS254	A.....
D	243	87-A40-470-080	DIODE,1SS254	A.....
D	241	87-A40-470-080	DIODE,1SS254	A.....
D	240	87-A40-470-080	DIODE,1SS254	A.....
D	244	87-A40-470-080	DIODE,1SS254	A.....
IC	202	87-A20-914-010	IC,SPS-442-1-F	A.....
IC	201	88-SP1-609-010	IC,UPD780228-XXXX	A.....
Q	201	87-A30-087-080	C-FET,2SK2158	A.....
Q	220	87-A30-071-080	C-TR,RT1N 144C	A.....
Q	241	87-026-263-080	C-TR,RN1410	A.....
Q	240	87-A30-074-080	C-TR,RT1P 141C	A.....
SW	201	87-A90-535-010	SW,RTRY EC16B24304	A.....
X	201	87-A70-075-080	VIB,CER 4.19MHZ CRHF	A.....
C	608	87-010-166-080	C-CAP,S 100P-50 SL	A.....
C	604	87-010-166-080	C-CAP,S 100P-50 SL	A.....
C	602	87-010-176-080	C-CAP,S 680P-50 SL	A.....
C	603	87-010-186-080	CAP,CHIP 4700P	A.....
C	605	87-010-321-080	CHIP CAPACITOR,82P(J)	A.....
C	601	87-010-405-040	CAP,E 10-50	A.....
C	609	87-010-545-040	CAP,E 0.22-50 SME	A.....
C	610	87-010-177-080	C-CAP,S 820P-50 SL	A.....
C	614	87-010-248-040	CAP,E 220-10 SME	A.....
C	615	87-010-378-040	CAP,E 10-16	A.....
C	611	87-010-406-040	CAP,E 22-50 SME	A.....
C	619	87-016-526-080	C-CAP,S 0.47-16 BK	A.....
CN	601	87-099-212-010	CONN,5P 6216 V	A.....
D	600	87-A40-470-080	DIODE,1SS254	A.....
FB	601	87-008-372-080	FILTER, EMI BL OIRNI	A.....
IC	601	87-017-888-080	IC,NJM4558MD	A.....
J	602	87-A60-284-010	JACK,3.5MO (MSC)	A.....
J	601	87-A60-284-010	JACK,3.5MO (MSC)	A.....
Q	600	87-A30-087-080	C-FET,2SK2158	A.....
C	804	87-010-159-080	C-CAP,S 27P-50 SL	A.....
C	805	87-010-159-080	C-CAP,S 27P-50 SL	A.....
C	802	87-010-196-080	CHIP CAPACITOR,0.1-25	A.....
C	801	87-010-263-040	CAP,E 100-10	A.....
C	803	87-010-405-040	CAP,E 10-50	A.....
C	806	87-016-526-080	C-CAP,S 0.47-16 BK	A.....
D	801	87-070-136-080	ZENER,MTZJ5.1B	A.....
D	802	87-A40-470-080	DIODE,1SS254	A.....
IC	801	88-NF5-615-040	C-IC,MSM6654A-521GS-KR1	A.....
X	801	87-A70-075-080	VIB,CER 4.19MHZ CRHF	A.....
C	0	87-010-374-080	CAP, ELECT 47-10V	A.....
C	503	87-010-180-080	C-CER 1500P	A.....
C	504	87-010-180-080	C-CER 1500P	A.....
C	513	87-010-404-080	CAP, ELECT 4.7-50V	A.....
C	514	87-010-404-080	CAP, ELECT 4.7-50V	A.....
C	511	87-010-405-080	CAP, ELECT 10-50V	A.....
C	512	87-010-405-080	CAP, ELECT 10-50V	A.....
C	519	87-012-142-080	CAP, S 0.33-16	A.....
C	522	87-010-183-080	C-CAP,S 2700P-50 B	A.....
C	521	87-010-194-080	CAP, CHIP 0.047	A.....
C	520	87-016-669-080	C-CAP,S 0.1-25 K B	A.....
C	523	87-016-669-080	C-CAP,S 0.1-25 K B	A.....
C	535	87-010-195-080	C-CAP,S 0.068-25 F	A.....
C	537	87-010-196-080	CHIP CAPACITOR,0.1-25	A.....
C	534	87-010-263-080	CAP, ELECT 100-10V	A.....
C	533	87-010-263-080	CAP, ELECT 100-10V	A.....
C	538	87-010-404-080	CAP, ELECT 4.7-50V	A.....
C	539	87-010-404-080	CAP, ELECT 4.7-50V	A.....
C	531	87-010-405-080	CAP, ELECT 10-50V	A.....
C	536	87-012-142-080	CAP, S 0.33-16	A.....
C	545	87-010-196-080	CHIP CAPACITOR,0.1-25	A.....
C	542	87-010-314-080	C-CAP,S 22P-50V	A.....

ELECTRICAL MAIN PARTS LIST - 2/8 (MX-NMT1000)

C	541	87-010-314-080	C-CAP,S 22P-50V	A
C	540	87-010-314-080	C-CAP,S 22P-50V	A
D	532	87-A40-438-080	ZENER,MTZJ4.7A	A
D	531	87-A40-438-080	ZENER,MTZJ4.7A	A
IC	501	87-A20-954-040	C-IC,M62445FP-601	A
		87-022-200-080	RESISTOR, METAL 0.56 1W	A
C	0	87-012-157-080	C-CAP,S 330P-50 CH	A
C	109	87-010-196-080	CHIP CAPACITOR,0.1-25	A
C	105	87-012-368-080	C-CAP,S 0.1-50 F	A
C	108	87-012-368-080	C-CAP,S 0.1-50 F	A
C	106	87-012-368-080	C-CAP,S 0.1-50 F	A
C	107	87-012-368-080	C-CAP,S 0.1-50 F	A
C	101	87-016-520-090	CAP,E 3300-65	A
C	102	87-016-520-090	CAP,E 3300-65	A
C	103	87-016-658-090	CAP,E 4700-35 SMG	A
C	104	87-016-658-090	CAP,E 4700-35 SMG	A
C	110	87-010-196-080	CHIP CAPACITOR,0.1-25	A
C	111	87-010-196-080	CHIP CAPACITOR,0.1-25	A
C	112	87-010-196-080	CHIP CAPACITOR,0.1-25	A
C	116	87-010-247-080	CAP, ELECT 100-50V	A
C	113	87-010-247-080	CAP, ELECT 100-50V	A
C	119	87-010-260-080	CAP, ELECT 47-25V	A
C	118	87-010-263-080	CAP, ELECT 100-10V	A
C	115	87-010-385-080	CAP, ELECT 220-25V	A
C	114	87-010-385-080	CAP, ELECT 220-25V	A
C	117	87-010-430-080	CAP, ELECT 100-63	A
C	124	87-010-112-080	CAP, ELECT 100-16V	A
C	121	87-010-174-080	CAP CHIP SL470P (K)	A
C	125	87-010-235-080	CAP,E 470-16 SME	A
C	123	87-010-247-080	CAP, ELECT 100-50V	A
C	122	87-010-263-080	CAP, ELECT 100-10V	A
C	120	87-010-403-080	CAP, ELECT 3.3-50V	A
C	130	87-010-399-010	CAP, ELECT 3300-35V	A
C	131	87-010-399-010	CAP, ELECT 3300-35V	A
C	132	87-012-368-080	C-CAP,S 0.1-50 F	A
C	133	87-012-368-080	C-CAP,S 0.1-50 F	A
C	900	87-010-178-080	CHIP CAP 1000P	A
C	908	87-010-190-080	S CHIP F 0.01	A
C	907	87-010-190-080	S CHIP F 0.01	A
C	904	87-010-196-080	CHIP CAPACITOR,0.1-25	A
C	906	87-010-196-080	CHIP CAPACITOR,0.1-25	A
C	905	87-010-196-080	CHIP CAPACITOR,0.1-25	A
C	903	87-010-196-080	CHIP CAPACITOR,0.1-25	A
C	909	87-012-368-080	C-CAP,S 0.1-50 F	A
C	910	87-012-368-080	C-CAP,S 0.1-50 F	A
C	942	87-010-196-080	CHIP CAPACITOR,0.1-25	A
C	941	87-010-196-080	CHIP CAPACITOR,0.1-25	A
C	945	87-010-196-080	CHIP CAPACITOR,0.1-25	A
C	944	87-010-993-080	C-CAP,S 0.056-25 B	A
C	943	87-010-993-080	C-CAP,S 0.056-25 B	A
C	946	87-010-993-080	C-CAP,S 0.056-25 B	A
CN	905	87-099-196-010	CONN,8P 6216 V	A
D	102	87-017-447-010	DIODE,GBU4DL	A
D	101	87-017-654-060	DIODE,GBU6J	A
D	107	87-070-274-080	DIODE,1N4003 SEM	A
D	109	87-070-274-080	DIODE,1N4003 SEM	A
D	108	87-070-274-080	DIODE,1N4003 SEM	A
D	106	87-070-274-080	DIODE,1N4003 SEM	A
D	104	87-A40-468-080	C-DIODE,HSM2836CTR	A
D	105	87-A40-469-080	C-DIODE,HSM2838CTR	A
D	103	87-A40-470-080	DIODE,1SS254	A
D	115	87-A40-004-080	ZENER,MTZJ16A	A
D	110	87-A40-341-080	ZENER,MTZJ 36 A	A
D	112	87-A40-345-080	ZENER,MTZJ10C	A
D	111	87-A40-468-080	C-DIODE,HSM2836CTR	A
D	130	87-017-447-010	DIODE,GBU4DL	A
FC	101	87-033-213-080	CLAMP, FUSE	A
FC	102	87-033-213-080	CLAMP, FUSE	A
J	901	87-A60-483-010	JACK,DIA6.3 BLK ST W/S KM	A
J	902	87-A60-617-010	TERMINAL,SP 4P (MSC)	A
J	903	87-A60-652-010	JACK,PIN 4P ORN/BLK	A
J	904	87-A60-658-010	JACK,PIN 6P WHITE/RED	A
J	905	87-A60-658-010	JACK,PIN 6P WHITE/RED	A
L	901	87-003-383-010	COIL,1UH-S	A
L	902	87-003-383-010	COIL,1UH-S	A
L	912	87-003-383-010	COIL,1UH-S	A
L	911	87-003-383-010	COIL,1UH-S	A
L	913	87-003-383-010	COIL,1UH-S	A
PR	105	87-026-681-080	PROTECTOR,5A 60V 491	A
PR	106	87-026-681-080	PROTECTOR,5A 60V 491	A
PR	103	87-026-682-080	PROTECTOR,10A 60V491	A
PR	104	87-026-682-080	PROTECTOR,10A 60V491	A
PR	106	87-026-690-080	FUSE,5A 125V 251	A
PR	105	87-026-690-080	FUSE,5A 125V 251	A
PR	104	87-026-691-080	FUSE,10A 125V 251	A
PR	103	87-026-691-080	FUSE,10A 125V 251	A
PR	101	87-A90-195-080	PROTECTOR 7A 125V 49	A
PR	102	87-A90-195-080	PROTECTOR 7A 125V 49	A
PR	102	87-A90-210-080	FUSE,7A 125V 251	A
PR	101	87-A90-210-080	FUSE,7A 125V 251	A
Q	103	87-026-610-080	TR,KTC3198GR	A
Q	109	87-A30-075-080	C-TR,2SA1235F	A

ELECTRICAL MAIN PARTS LIST - 3/8 (MX-NMT1000)

Q	107	87-A30-075-080	C-TR,2SA1235F	A
Q	106	87-A30-076-080	C-TR,2SC3052F	A
Q	108	87-A30-076-080	C-TR,2SC3052F	A
Q	104	87-A30-076-080	C-TR,2SC3052F	A
Q	105	87-A30-083-080	TR,CSD1489B	A
Q	101	89-213-702-010	TR,2SB1370 (1.8W)	A
Q	102	89-213-702-010	TR,2SB1370 (1.8W)	A
Q	111	87-026-609-080	TR,KTA1266GR	A
Q	112	87-026-609-080	TR,KTA1266GR	A
Q	115	87-A30-075-080	C-TR,2SA1235F	A
Q	114	87-A30-075-080	C-TR,2SA1235F	A
Q	110	87-A30-076-080	C-TR,2SC3052F	A
R	909	87-A00-126-080	RES M/F 220-1/WJ VIP	A
R	911	87-A00-126-080	RES M/F 220-1/WJ VIP	A
R	910	87-A00-126-080	RES M/F 220-1/WJ VIP	A
R	912	87-A00-126-080	RES M/F 220-1/WJ VIP	A
RY	101	87-A90-464-010	RELAY, DG12D2-O(M)	A
S	101	87-036-173-010	SW,SL 2-2-4 SDKG(*)	A
T	102	87-A60-317-010	TERMINAL, 1P MSC	A
T	101	87-A60-317-010	TERMINAL, 1P MSC	A
W	0	88-SP1-625-010	WIRE ASSY,1P (GRN)	A
W	0	88-SP1-626-010	WIRE ASSY,1P (YEL)	A
W	0	88-SP1-627-010	WIRE ASSY,1P (BLU)	A
W	0	88-SP1-628-010	WIRE ASSY,1P (BLK)	A
W	0	88-SP1-629-010	WIRE ASSY,1P (WHT)	A
W	101	85-NF5-628-010	F-CABLE 7P-2.5	A
C	201	87-010-322-080	C-CAP,S 100P-50 CH	A
C	202	87-010-322-080	C-CAP,S 100P-50 CH	A
C	209	87-010-403-080	CAP, ELECT 3.3-50V	A
C	213	87-010-186-080	CAP,CHIP 4700P	A
C	214	87-010-186-080	CAP,CHIP 4700P	A
C	211	87-010-187-080	CAP CHIP S5600P	A
C	212	87-010-187-080	CAP CHIP S5600P	A
C	217	87-010-260-080	CAP, ELECT 47-25V	A
C	218	87-010-260-080	CAP, ELECT 47-25V	A
C	215	87-010-403-080	CAP, ELECT 3.3-50V	A
C	216	87-010-403-080	CAP, ELECT 3.3-50V	A
C	210	87-010-403-080	CAP, ELECT 3.3-50V	A
C	219	87-A10-516-080	C-CAP,S 100P-200 J CH	A
C	223	87-010-405-080	CAP, ELECT 10-50V	A
C	227	87-010-407-080	CAP, ELECT 33-50V	A
C	220	87-A10-516-080	C-CAP,S 100P-200 J CH	A
C	231	87-010-186-080	CAP,CHIP 4700P	A
C	232	87-010-186-080	CAP,CHIP 4700P	A
C	235	87-010-196-080	CHIP CAPACITOR,0.1-25	A
C	234	87-010-401-080	CAP, ELECT 1-50V	A
C	233	87-010-401-080	CAP, ELECT 1-50V	A
D	207	87-A40-470-080	DIODE,1SS254	A
D	208	87-A40-470-080	DIODE,1SS254	A
D	209	87-A40-470-080	DIODE,1SS254	A
D	203	87-A40-470-080	DIODE,1SS254	A
D	201	87-A40-470-080	DIODE,1SS254	A
D	205	87-A40-470-080	DIODE,1SS254	A
D	206	87-A40-470-080	DIODE,1SS254	A
D	202	87-A40-470-080	DIODE,1SS254	A
D	204	87-A40-470-080	DIODE,1SS254	A
D	213	87-070-136-080	ZENER,MTZJ5.1B	A
D	214	87-070-136-080	ZENER,MTZJ5.1B	A
D	211	87-A40-370-090	DIODE,RK46-P20	A
D	212	87-A40-370-090	DIODE,RK46-P20	A
D	210	87-A40-470-080	DIODE,1SS254	A
D	218	87-A40-470-080	DIODE,1SS254	A
D	219	87-A40-470-080	DIODE,1SS254	A
D	216	87-A40-470-080	DIODE,1SS254	A
D	215	87-A40-470-080	DIODE,1SS254	A
D	217	87-A40-470-080	DIODE,1SS254	A
D	220	87-A40-345-080	ZENER,MTZJ10C	A
D	225	87-A40-470-080	DIODE,1SS254	A
D	221	87-A40-470-080	DIODE,1SS254	A
D	226	87-A40-470-080	DIODE,1SS254	A
D	227	87-A40-470-080	DIODE,1SS254	A
D	222	87-A40-470-080	DIODE,1SS254	A
D	223	87-A40-488-080	DIODE,1SS244	A
D	224	87-A40-488-080	DIODE,1SS244	A
D	295	87-A40-470-080	DIODE,1SS254	A
D	296	87-A40-470-080	DIODE,1SS254	A
Q	204	87-A30-075-080	C-TR,2SA1235F	A
Q	202	87-A30-086-040	C-TR,CSD1306E	A
Q	201	87-A30-086-040	C-TR,CSD1306E	A
Q	207	87-A30-107-080	C-TR,CMBT5401	A
Q	208	87-A30-107-080	C-TR,CMBT5401	A
Q	209	87-A30-107-080	C-TR,CMBT5401	A
Q	213	87-A30-076-080	C-TR,2SC3052F	A
Q	214	87-A30-076-080	C-TR,2SC3052F	A
Q	211	87-A30-076-080	C-TR,2SC3052F	A
Q	212	87-A30-076-080	C-TR,2SC3052F	A
Q	217	87-A30-097-010	TR, FN 1016	A
Q	218	87-A30-097-010	TR, FN 1016	A
Q	219	87-A30-098-010	TR, FP 1016	A
Q	210	87-A30-107-080	C-TR,CMBT5401	A
Q	216	87-A30-190-080	TR,CC5551	A
Q	215	87-A30-190-080	TR,CC5551	A

ELECTRICAL MAIN PARTS LIST - 4/8 (MX-NMT1000)

Q	227	87-A30-072-080	C-TR,RT1P 144C	A
Q	228	87-A30-073-080	C-TR,RT1N 141C	A
Q	226	87-A30-075-080	C-TR,2SA1235F	A
Q	225	87-A30-076-080	C-TR,2SC3052F	A
Q	220	87-A30-098-010	TR,FP 1016	A
Q	222	87-A30-106-080	C-TR,CMBT5551	A
Q	221	87-A30-106-080	C-TR,CMBT5551	A
Q	229	87-A30-107-080	C-TR,CMBT5401	A
Q	223	87-A30-162-010	FET,2SK2937	A
Q	224	87-A30-162-010	FET,2SK2937	A
Q	291	87-A30-074-080	C-TR,RT1P 141C	A
Q	295	87-A30-106-080	C-TR,CMBT5551	A
Q	290	87-A30-107-080	C-TR,CMBT5401	A
R	239	87-A00-262-080	RES,M/F 0.15-2W J	A
R	238	87-A00-262-080	RES,M/F 0.15-2W J	A
R	237	87-A00-262-080	RES,M/F 0.15-2W J	A
R	240	87-A00-262-080	RES,M/F 0.15-2W J	A
TH	201	87-A90-221-080	C-THMS,100K	A
TH	202	87-A90-221-080	C-THMS,100K	A
		88-SP1-211-010	GUIDE,FUN	A
		88-SX1-203-010	GUIDE,FL	A
C	101	87-010-196-080	CHIP CAPACITOR,0.1-25	A
C	301	87-010-404-080	CAP, ELECT 4.7-50V	A
C	302	87-010-404-080	CAP, ELECT 4.7-50V	A
D	304	87-A40-470-080	DIODE,1SS254	A
D	305	87-A40-470-080	DIODE,1SS254	A
D	302	87-A40-470-080	DIODE,1SS254	A
D	301	87-A40-470-080	DIODE,1SS254	A
D	303	87-A40-470-080	DIODE,1SS254	A
FL	301	88-SP1-610-010	FL,10-BT-208GK	A
LED	304	87-A40-497-080	LED,SML11516C	A
LED	305	87-A40-497-080	LED,SML11516C	A
LED	302	87-A40-497-080	LED,SML11516C	A
LED	301	87-A40-497-080	LED,SML11516C	A
LED	303	87-A40-497-080	LED,SML11516C	A
Q	307	87-026-226-080	CHIP-TR,DTA143EK	A
Q	303	87-A30-071-080	C-TR,RT1N 144C	A
Q	305	87-A30-071-080	C-TR,RT1N 144C	A
Q	304	87-A30-071-080	C-TR,RT1N 144C	A
Q	301	87-A30-071-080	C-TR,RT1N 144C	A
Q	302	87-A30-071-080	C-TR,RT1N 144C	A
Q	306	89-112-965-080	TR,2SA1296 (0.75W)	A
S	307	87-A90-809-080	SW,TACT TSTA-2	A
S	309	87-A90-809-080	SW,TACT TSTA-2	A
S	301	87-A90-809-080	SW,TACT TSTA-2	A
S	303	87-A90-809-080	SW,TACT TSTA-2	A
S	308	87-A90-809-080	SW,TACT TSTA-2	A
S	305	87-A90-809-080	SW,TACT TSTA-2	A
S	304	87-A90-809-080	SW,TACT TSTA-2	A
S	306	87-A90-809-080	SW,TACT TSTA-2	A
S	302	87-A90-809-080	SW,TACT TSTA-2	A
S	310	87-A90-809-080	SW,TACT TSTA-2	A
S	314	87-A90-809-080	SW,TACT TSTA-2	A
S	311	87-A90-809-080	SW,TACT TSTA-2	A
S	313	87-A90-809-080	SW,TACT TSTA-2	A
S	312	87-A90-809-080	SW,TACT TSTA-2	A
S	315	87-A90-809-080	SW,TACT TSTA-2	A
C	0	87-010-374-080	CAP, ELECT 47-10V	A
C	603	87-010-182-080	C-CAP,S 2200P-50 B	A
C	604	87-010-182-080	C-CAP,S 2200P-50 B	A
C	606	87-010-369-080	C-CAP,S 0.033-25 K B	A
C	605	87-010-369-080	C-CAP,S 0.033-25 K B	A
C	608	87-010-402-080	CAP, ELECT 2.2-50V	A
C	607	87-010-402-080	CAP, ELECT 2.2-50V	A
C	602	87-010-545-040	CAP,E 0.22-50 SME	A
C	601	87-010-545-040	CAP,E 0.22-50 SME	A
C	612	87-010-112-080	CAP, ELECT 100-16V	A
C	614	87-010-184-080	CHIP CAPACITOR 3300P(K)	A
C	613	87-010-184-080	CHIP CAPACITOR 3300P(K)	A
C	611	87-010-405-080	CAP, ELECT 10-50V	A
CN	611	87-099-212-010	CONN,5P 6216 V	A
IC	601	87-A20-804-040	C-IC,NJM2152M	A
C	0	87-010-544-080	CAP, ELECT 0.1-50V	A
C	701	87-010-402-080	CAP, ELECT 2.2-50V	A
C	702	87-010-402-080	CAP, ELECT 2.2-50V	A
C	709	87-010-956-080	CHIP-CAP,S 0.068-25B	A
C	708	87-012-365-080	C-CAP,S 0.027-25VBK	A
C	707	87-012-365-080	C-CAP,S 0.027-25VBK	A
C	705	87-016-460-080	C-CAP,S 0.22-16 B	A
C	706	87-016-460-080	C-CAP,S 0.22-16 B	A
C	703	87-016-669-080	C-CAP,S 0.1-25 K B	A
C	704	87-016-669-080	C-CAP,S 0.1-25 K B	A
C	719	87-010-178-080	CHIP CAP 1000P	A
C	716	87-010-183-080	C-CAP,S 2700P-50 B	A
C	715	87-010-183-080	C-CAP,S 2700P-50 B	A
C	717	87-010-188-080	CAP,CHIP 6800P	A
C	718	87-010-188-080	CAP,CHIP 6800P	A
C	711	87-010-197-080	CAP, CHIP 0.01 DM	A
C	712	87-010-197-080	CAP, CHIP 0.01 DM	A
C	713	87-010-198-080	CAP, CHIP 0.022	A
C	714	87-010-198-080	CAP, CHIP 0.022	A
C	710	87-010-956-080	CHIP-CAP,S 0.068-25B	A

ELECTRICAL MAIN PARTS LIST - 5/8 (MX-NMT1000)

C	720	87-010-178-080	CHIP CAP 1000P	A.....
C	721	87-010-182-080	C-CAP,S 2200P-50 B	A.....
C	722	87-010-182-080	C-CAP,S 2200P-50 B	A.....
C	731	87-010-112-080	CAP, ELECT 100-16V	A.....
C	738	87-010-196-080	CHIP CAPACITOR,0.1-25	A.....
C	736	87-010-322-080	C-CAP,S 100P-50 CH	A.....
C	735	87-010-322-080	C-CAP,S 100P-50 CH	A.....
C	737	87-010-322-080	C-CAP,S 100P-50 CH	A.....
C	730	87-010-404-080	CAP, ELECT 4.7-50V	A.....
IC	701	87-A20-869-040	C-IC,M62449FP	A.....
		88-AR1-625-010	PWB,TUNER HE HR 4M
C	701	87-010-260-080	CAP, ELECT 47-25V	A.....
C	702	87-010-404-080	CAP, ELECT 4.7-50V	A.....
C	709	87-012-195-080	C-CAP,U 100P-50CH	A.....
C	703	87-012-286-080	CAP, U 0.01-25	A.....
C	704	87-012-286-080	CAP, U 0.01-25	A.....
C	712	87-010-196-080	CHIP CAPACITOR,0.1-25	A.....
C	711	87-010-263-080	CAP, ELECT 100-10V	A.....
C	715	87-010-322-080	C-CAP,S 100P-50 CH
C	715	87-012-195-080	C-CAP,U 100P-50CH
C	717	87-012-286-080	CAP, U 0.01-25	A.....
C	714	87-012-286-080	CAP, U 0.01-25	A.....
C	713	87-012-286-080	CAP, U 0.01-25	A.....
C	719	87-012-286-080	CAP, U 0.01-25	A.....
C	727	87-010-196-080	CHIP CAPACITOR,0.1-25	A.....
C	728	87-010-248-080	CAP, ELECT 220-10V	A.....
C	721	87-012-176-080	CAP 15P	A.....
C	722	87-012-176-080	CAP 15P	A.....
C	720	87-012-195-080	C-CAP,U 100P-50CH
C	725	87-012-274-080	CHIP CAP,U 1000P-50B	A.....
C	723	87-012-274-080	CHIP CAP,U 1000P-50B	A.....
CN	601	87-099-028-010	CONN,11P 6216 H	A.....
D	710	87-A40-470-080	DIODE,1SS254
D	721	87-A40-234-080	ZENER,MTZJ5.6A	A.....
IC	721	86-NFZ-655-010	IC,LC72131D(Z)	A.....
	711	87-A30-083-080	TR,CSD1489B	A.....
X	721	87-A70-061-010	VIB,XTAL 4.500MHZ CSA-309	A.....
C	758	87-012-167-080	C-CAP,U 5P-50 CH	A.....
C	757	87-012-188-080	C-CAP,U 47P-50 CH	A.....
C	756	87-012-286-080	CAP, U 0.01-25	A.....
C	755	87-012-286-080	CAP, U 0.01-25	A.....
C	761	87-010-196-080	CHIP CAPACITOR,0.1-25	A.....
C	769	87-010-260-080	CAP, ELECT 47-25V
C	769	87-010-408-080	CAP, ELECT 47-50V	A.....
C	763	87-010-829-080	CAP, U 0.047-16	A.....
C	765	87-012-286-080	CAP, U 0.01-25	A.....
C	766	87-012-286-080	CAP, U 0.01-25	A.....
C	764	87-012-337-080	C-CAP,U 56P-50 CH	A.....
C	773	87-010-196-080	CHIP CAPACITOR,0.1-25	A.....
C	774	87-010-263-080	CAP, ELECT 100-10V	A.....
C	771	87-010-383-080	CAP, ELECT 33-25V	A.....
C	777	87-010-400-080	CAP, ELECT 0.47-50V	A.....
C	779	87-010-401-080	CAP, ELECT 1-50V	A.....
C	778	87-010-401-080	CAP, ELECT 1-50V	A.....
C	775	87-010-404-080	CAP, ELECT 4.7-50V	A.....
C	771	87-010-407-080	CAP, ELECT 33-50V
C	770	87-010-829-080	CAP, U 0.047-16	A.....
C	772	87-010-829-080	CAP, U 0.047-16	A.....
C	776	87-012-286-080	CAP, U 0.01-25	A.....
C	780	87-010-196-080	CHIP CAPACITOR,0.1-25	A.....
C	781	87-010-405-080	CAP, ELECT 10-50V	A.....
C	782	87-010-405-080	CAP, ELECT 10-50V	A.....
C	789	87-012-275-080	C-CAP,U 1200P-50 B	A.....
C	788	87-012-280-080	CAP, U 3300P-50	A.....
C	787	87-012-280-080	CAP, U 3300P-50	A.....
C	784	87-012-286-080	CAP, U 0.01-25	A.....
C	783	87-012-286-080	CAP, U 0.01-25	A.....
C	793	87-010-177-080	C-CAP,S 820P-50 SL
C	796	87-010-403-080	CAP, ELECT 3.3-50V	A.....
C	791	87-010-405-080	CAP, ELECT 10-50V	A.....
C	794	87-010-406-080	CAP, ELECT 22-50	A.....
C	795	87-010-596-080	CAP, S 0.047-16	A.....
C	799	87-010-829-080	CAP, U 0.047-16	A.....
C	793	87-012-273-080	C-CAP,U 820P-50 B	A.....
C	790	87-012-275-080	C-CAP,U 1200P-50 B	A.....
C	798	87-012-276-080	CAP, CHIP SS 1500 PBK
C	797	87-012-276-080	CAP, CHIP SS 1500 PBK
C	798	87-012-278-080	C-CAP,U 2200P-50 B	A.....
C	797	87-012-278-080	C-CAP,U 2200P-50 B	A.....
D	771	87-A40-470-080	DIODE,1SS254
D	773	87-A40-470-080	DIODE,1SS254	A.....
IC	771	87-A20-438-010	IC,LA1837	A.....
IC	771	87-A20-913-010	IC,LA1837NL
L	771	87-A50-266-010	COIL,FM DET-2N(TOK)	A.....
L	772	87-A90-052-010	FLTR,CFMT-450A(TOK)
L	772	87-A90-733-010	FLTR,PCFAZH-450 (TOK)	A.....
L	781	87-005-847-080	COIL,2.2UH(CECS)	A.....
L	791	87-A50-027-010	COIL,1 POLE MPX(TOK)
L	792	87-A50-027-010	COIL,1 POLE MPX(TOK)
L	791	87-A50-209-010	COIL,1POLE MPX(MIT)	A.....
L	792	87-A50-209-010	COIL,1POLE MPX(MIT)	A.....
X	771	87-030-354-010	VIB,CF BFU 450C

ELECTRICAL MAIN PARTS LIST - 6/8 (MX-NMT1000)

C	813	87-010-197-080	CAP, CHIP 0.01 DM	A
C	818	87-010-197-080	CAP, CHIP 0.01 DM	.
C	819	87-010-197-080	CAP, CHIP 0.01 DM	A
C	814	87-012-286-080	CAP, U 0.01-25	A
C	812	87-012-286-080	CAP, U 0.01-25	A
C	829	87-010-196-080	CHIP CAPACITOR,0.1-25	A
C	828	87-010-196-080	CHIP CAPACITOR,0.1-25	A
C	820	87-010-260-080	CAP, ELECT 47-25V	.
C	820	87-010-408-080	CAP, ELECT 47-50V	A
C	821	87-012-286-080	CAP, U 0.01-25	A
C	823	87-012-286-080	CAP, U 0.01-25	A
C	822	87-012-286-080	CAP, U 0.01-25	A
C	944	87-010-575-080	C-CAP,S 560P-50 UJ	.
C	942	87-012-172-080	CAPACITOR CHIP U 10P CH	.
C	941	87-012-180-080	C-CAP,U 22P-50 CH	.
C	947	87-012-286-080	CAP, U 0.01-25	.
C	943	87-012-286-080	CAP, U 0.01-25	.
C	945	87-012-286-080	CAP, U 0.01-25	.
C	940	87-012-286-080	CAP, U 0.01-25	.
C	949	87-A10-039-080	C-CAP,U 470P-50 J CH	.
C	959	87-010-196-080	CHIP CAPACITOR,0.1-25	A
C	956	87-010-263-080	CAP, ELECT 100-10V	.
C	957	87-010-311-080	CAP 12P	.
C	954	87-010-400-080	CAP, ELECT 0.47-50V	.
C	958	87-012-286-080	CAP, U 0.01-25	.
C	953	87-012-286-080	CAP, U 0.01-25	.
C	952	87-012-286-080	CAP, U 0.01-25	.
C	950	87-A10-913-080	C-CAP, 4700P-50 J CH	.
C	960	87-010-196-080	CHIP CAPACITOR,0.1-25	A
C	962	87-010-401-080	CAP, ELECT 1-50V	.
C	961	87-012-170-080	C-CAP,U 8P-50 CH	A
CF	802	82-785-747-010	CF MS2 GHY R	.
CF	801	87-008-261-010	FILTER, SFE10.7MA5-A	A
CF	802	87-008-261-010	FILTER, SFE10.7MA5-A	A
CF	801	87-008-423-010	CERAMIC FILTER, SFE10.7	.
D	942	87-A40-270-080	C-DIODE,MC2838	.
D	941	87-A40-470-080	DIODE,1SS254	.
D	944	87-A40-470-080	DIODE,1SS254	.
FFE	801	A8-6ZA-191-130	6ZA-1 FEENM	.
FFE	801	A8-8ZA-190-030	8ZA-1 FEUNM	A
FFE	801	A8-8ZA-193-070	8ZA-1 YFEUNC	.
J	801	87-A60-202-010	TERMINAL,ANT 4P MSP-154V-02	.
J	801	87-A60-657-010	TERMINAL,4P HSP-154V5-02	A
L	832	87-005-847-080	COIL,2.2UH(CECS)	A
L	943	87-005-372-080	COIL S 1MHM	.
L	942	87-A50-019-010	COIL,OSC LW(COI)	.
L	941	87-A50-020-010	COIL,ANT LW(COI)	.
L	945	87-A50-022-010	COIL,ANT SW(COI)	.
L	944	87-A50-159-010	COIL,10MH K C2B	.
L	946	87-A50-173-010	COIL,OSC SW-N(COI)	.
L	983	86-NF4-666-010	AM PACK 3(TOK)	.
L	981	87-NF4-650-010	COIL,AM PACK 4N(TOK)	A
L	981	87-NF4-651-010	COIL,AM PACK2N(TOM)	.
Q	807	87-A30-072-080	C-TR,RT1P 144C	.
Q	806	87-A30-072-080	C-TR,RT1P 144C	A
Q	805	89-327-143-080	TR,2SC2714 (0.1W)	A
Q	941	87-A30-074-080	C-TR,RT1P 141C	.
Q	943	87-A30-075-080	C-TR,2SA1235F	.
Q	942	87-A30-075-080	C-TR,2SA1235F	.
Q	945	87-A30-076-080	C-TR,2SC3052F	.
Q	944	87-A30-076-080	C-TR,2SC3052F	.
Q	949	87-A30-076-080	C-TR,2SC3052F	.
Q	946	87-A30-086-070	C-TR,CSD1306E	.
Q	948	87-A30-086-070	C-TR,CSD1306E	.
Q	947	89-503-602-080	C-FET,2SK360E	.
Q	951	87-A30-074-080	C-TR,RT1P 141C	.
Q	950	87-A30-086-070	C-TR,CSD1306E	.
Q	952	87-A30-086-070	C-TR,CSD1306E	.
TC	942	87-011-164-010	CAPACITOR,TRIMMER 30P	.
TC	943	87-011-164-010	CAPACITOR,TRIMMER 30P	.
TC	941	87-011-173-010	CERAMIC TRIMMER 20P	.
C	404	87-010-401-080	CAP, ELECT 1-50V	A
C	405	87-010-401-080	CAP, ELECT 1-50V	A
C	403	87-010-401-080	CAP, ELECT 1-50V	A
C	406	87-010-401-080	CAP, ELECT 1-50V	A
C	402	87-010-404-080	CAP, ELECT 4.7-50V	A
C	401	87-010-404-080	CAP, ELECT 4.7-50V	A
C	408	87-010-544-080	CAP, ELECT 0.1-50V	A
C	407	87-016-669-080	C-CAP,S 0.1-25 K B	A
C	419	87-010-401-080	CAP, ELECT 1-50V	A
C	410	87-010-401-080	CAP, ELECT 1-50V	A
C	412	87-012-349-080	C-CAP,S 1000P-50 CH	A
C	418	87-012-349-080	C-CAP,S 1000P-50 CH	A
C	420	87-010-401-080	CAP, ELECT 1-50V	A
C	427	87-010-404-080	CAP, ELECT 4.7-50V	A
C	426	87-010-404-080	CAP, ELECT 4.7-50V	A
C	425	87-016-460-080	C-CAP,S 0.22-16 B	A
C	428	87-016-460-080	C-CAP,S 0.22-16 B	A
C	429	87-016-460-080	C-CAP,S 0.22-16 B	A
C	424	87-016-460-080	C-CAP,S 0.22-16 B	A
C	423	87-A10-229-080	C-CAP,S 0.68-10 K W5	A
C	439	87-010-994-080	C-CAP,S 680P-50 CH	A

ELECTRICAL MAIN PARTS LIST - 7/8(MX-NMT1000)

C	438	87-010-994-080	C-CAP,S 680P-50 CH	A
C	430	87-016-669-080	C-CAP,S 0.1-25 K B	A
C	433	87-016-669-080	C-CAP,S 0.1-25 K B	A
C	434	87-016-669-080	C-CAP,S 0.1-25 K B	A
C	437	87-016-669-080	C-CAP,S 0.1-25 K B	A
C	436	88-710-839-810	CAP,M 0.022-50 J TFL	A
C	435	88-710-839-810	CAP,M 0.022-50 J TFL	A
C	446	87-010-374-080	CAP, ELECT 47-10V	A
C	444	87-A10-891-080	CAP,E 4.7-25 SME(K)	A
C	451	87-010-112-080	CAP, ELECT 100-16V	A
C	452	87-010-196-080	CHIP CAPACITOR,0.1-25	A
C	459	87-010-196-080	CHIP CAPACITOR,0.1-25	A
C	457	87-010-196-080	CHIP CAPACITOR,0.1-25	A
C	455	87-010-196-080	CHIP CAPACITOR,0.1-25	A
C	453	87-010-248-080	CAP, ELECT 220-10V	A
C	454	87-010-263-080	CAP, ELECT 100-10V	A
C	456	87-010-374-080	CAP, ELECT 47-10V	A
C	458	87-010-374-080	CAP, ELECT 47-10V	A
C	462	87-010-314-080	C-CAP,S 22P-50V	A
C	461	87-010-314-080	C-CAP,S 22P-50V	A
C	463	87-010-314-080	C-CAP,S 22P-50V	A
D	401	87-A40-470-080	DIODE,1SS254	A
D	402	87-A40-470-080	DIODE,1SS254	A
D	451	87-070-136-080	ZENER,MTZJ5.1B	A
D	452	87-A40-442-080	ZENER,MTZJ9.1A	A
IC	402	87-020-818-080	IC,TC4066BF	A
IC	403	87-020-818-080	IC,TC4066BF	A
IC	401	87-A20-853-010	C-IC,M62463FP	A
Q	401	87-A30-074-080	C-TR,RT1P 141C	A
Q	402	87-A30-104-080	C-TR,RT1N 441C	A
C	952	87-010-263-080	CAP, ELECT 100-10V	A
C	953	87-010-380-080	CAP, ELECT 47-16V	A
C	951	87-010-401-080	CAP, ELECT 1-50V	A
D	952	87-A40-470-080	DIODE,1SS254	A
D	951	87-A40-470-080	DIODE,1SS254	A
Q	952	87-026-609-080	TR,KTA1266GR	A
Q	951	87-A30-076-080	C-TR,2SC3052F	A
C	0	87-010-182-080	C-CAP,S 2200P-50 B	A
C	0	87-012-145-080	CAP, CHIP S 270P CH	A
C	304	87-010-178-080	CHIP CAP 1000P	A
C	303	87-010-178-080	CHIP CAP 1000P	A
C	308	87-010-322-080	C-CAP,S 100P-50 CH	A
C	307	87-010-322-080	C-CAP,S 100P-50 CH	A
C	301	87-010-402-080	CAP, ELECT 2.2-50V	A
C	302	87-010-402-080	CAP, ELECT 2.2-50V	A
C	306	87-010-404-080	CAP, ELECT 4.7-50V	A
C	305	87-010-404-080	CAP, ELECT 4.7-50V	A
C	309	87-010-405-080	CAP, ELECT 10-50V	A
C	312	87-010-184-080	CHIP CAPACITOR 3300P(K)	A
C	311	87-010-184-080	CHIP CAPACITOR 3300P(K)	A
C	313	87-010-260-080	CAP, ELECT 47-25V	A
C	314	87-010-260-080	CAP, ELECT 47-25V	A
C	310	87-010-405-080	CAP, ELECT 10-50V	A
C	317	87-010-544-080	CAP, ELECT 0.1-50V	A
C	318	87-010-544-080	CAP, ELECT 0.1-50V	A
C	316	87-A10-596-080	C-CAP,S 100P-100 J CH	A
C	315	87-A10-596-080	C-CAP,S 100P-100 J CH	A
C	352	87-010-178-080	CHIP CAP 1000P	A
C	356	87-010-184-080	CHIP CAPACITOR 3300P(K)	A
C	357	87-010-260-080	CAP, ELECT 47-25V	A
C	354	87-010-322-080	C-CAP,S 100P-50 CH	A
C	351	87-010-402-080	CAP, ELECT 2.2-50V	A
C	353	87-010-404-080	CAP, ELECT 4.7-50V	A
C	355	87-010-405-080	CAP, ELECT 10-50V	A
C	359	87-010-544-080	CAP, ELECT 0.1-50V	A
C	358	87-A10-596-080	C-CAP,S 100P-100 J CH	A
C	381	87-010-402-080	CAP, ELECT 2.2-50V	A
C	391	87-010-401-080	CAP, ELECT 1-50V	A
D	305	87-A40-470-080	DIODE,1SS254	A
D	306	87-A40-470-080	DIODE,1SS254	A
D	307	87-A40-470-080	DIODE,1SS254	A
D	303	87-A40-470-080	DIODE,1SS254	A
D	308	87-A40-470-080	DIODE,1SS254	A
D	301	87-A40-470-080	DIODE,1SS254	A
D	304	87-A40-470-080	DIODE,1SS254	A
D	302	87-A40-470-080	DIODE,1SS254	A
D	309	87-A40-470-080	DIODE,1SS254	A
D	315	87-A40-470-080	DIODE,1SS254	A
D	316	87-A40-470-080	DIODE,1SS254	A
D	317	87-A40-470-080	DIODE,1SS254	A
D	310	87-A40-470-080	DIODE,1SS254	A
D	318	87-A40-470-080	DIODE,1SS254	A
D	312	87-A40-488-080	DIODE,1SS244	A
D	311	87-A40-488-080	DIODE,1SS244	A
D	351	87-A40-470-080	DIODE,1SS254	A
D	355	87-A40-470-080	DIODE,1SS254	A
D	352	87-A40-470-080	DIODE,1SS254	A
D	354	87-A40-470-080	DIODE,1SS254	A
D	353	87-A40-470-080	DIODE,1SS254	A
D	356	87-A40-488-080	DIODE,1SS244	A
Q	303	87-A30-075-080	C-TR,2SA1235F	A
Q	306	87-A30-075-080	C-TR,2SA1235F	A

ELECTRICAL MAIN PARTS LIST - 8/8 (MX-NMT1000)

Q	305	87-A30-075-080	C-TR,2SA1235F	A.....
Q	304	87-A30-075-080	C-TR,2SA1235F	A.....
Q	307	87-A30-076-080	C-TR,2SC3052F	A.....
Q	308	87-A30-076-080	C-TR,2SC3052F	A.....
Q	309	87-A30-076-080	C-TR,2SC3052F	A.....
Q	301	87-A30-086-080	C-TR,CSD1306E	A.....
Q	302	87-A30-086-080	C-TR,CSD1306E	A.....
Q	310	87-A30-076-080	C-TR,2SC3052F	A.....
Q	318	87-A30-076-080	C-TR,2SC3052F	A.....
Q	317	87-A30-076-080	C-TR,2SC3052F	A.....
Q	316	87-A30-108-010	TR,2SB1626	A.....
Q	315	87-A30-108-010	TR,2SB1626	A.....
Q	314	87-A30-109-010	TR,2SD 2495	A.....
Q	313	87-A30-109-010	TR,2SD 2495	A.....
Q	312	87-A30-190-080	TR,CC5551	A.....
Q	311	87-A30-190-080	TR,CC5551	A.....
Q	353	87-A30-075-080	C-TR,2SA1235F	A.....
Q	352	87-A30-075-080	C-TR,2SA1235F	A.....
Q	355	87-A30-076-080	C-TR,2SC3052F	A.....
Q	354	87-A30-076-080	C-TR,2SC3052F	A.....
Q	359	87-A30-076-080	C-TR,2SC3052F	A.....
Q	351	87-A30-086-080	C-TR,CSD1306E	A.....
Q	358	87-A30-108-010	TR,2SB1626	A.....
Q	357	87-A30-109-010	TR,2SD 2495	A.....
Q	356	87-A30-190-080	TR,CC5551	A.....
Q	360	87-A30-107-080	C-TR,CMBT5401	A.....
Q	381	87-A30-086-080	C-TR,CSD1306E	A.....
R	331	87-022-050-080	RES,M/F 0.22-1W J	A.....
R	332	87-022-050-080	RES,M/F 0.22-1W J	A.....
R	333	87-022-050-080	RES,M/F 0.22-1W J	A.....
R	334	87-022-050-080	RES,M/F 0.22-1W J	A.....
R	367	87-022-050-080	RES,M/F 0.22-1W J	A.....
R	366	87-022-050-080	RES,M/F 0.22-1W J	A.....
C	805	87-010-154-080	CAP CHIP 10P	A.....
C	806	87-010-378-080	CAP, ELECT 10-16V	A.....
C	807	87-010-378-080	CAP, ELECT 10-16V	A.....
C	801	87-010-401-080	CAP, ELECT 1-50V	A.....
C	802	87-010-401-080	CAP, ELECT 1-50V	A.....
C	841	87-010-154-080	CAP CHIP 10P	A.....
C	857	87-010-196-080	CHIP CAPACITOR,0.1-25	A.....
C	856	87-010-196-080	CHIP CAPACITOR,0.1-25	A.....
C	853	87-010-196-080	CHIP CAPACITOR,0.1-25	A.....
C	854	87-010-196-080	CHIP CAPACITOR,0.1-25	A.....
C	858	87-010-374-080	CAP, ELECT 47-10V	A.....
C	851	87-010-374-080	CAP, ELECT 47-10V	A.....
C	852	87-010-374-080	CAP, ELECT 47-10V	A.....
C	855	87-010-374-080	CAP, ELECT 47-10V	A.....
C	881	87-010-260-080	CAP, ELECT 47-25V	A.....
D	802	87-A40-466-080	ZENER,MTZJ2.7A	A.....
D	801	87-A40-466-080	ZENER,MTZJ2.7A	A.....
IC	802	87-017-726-080	IC,BU4052 BCF	A.....
IC	801	87-A20-715-010	IC,M62439SP	A.....
Q	883	87-A30-075-080	C-TR,2SA1235F	A.....
Q	882	87-A30-076-080	C-TR,2SC3052F	A.....
Q	881	87-A30-087-080	C-FET,2SK2158	A.....

SCHEMATIC DIAGRAM – 1 (MX-NMT1000: MAIN)

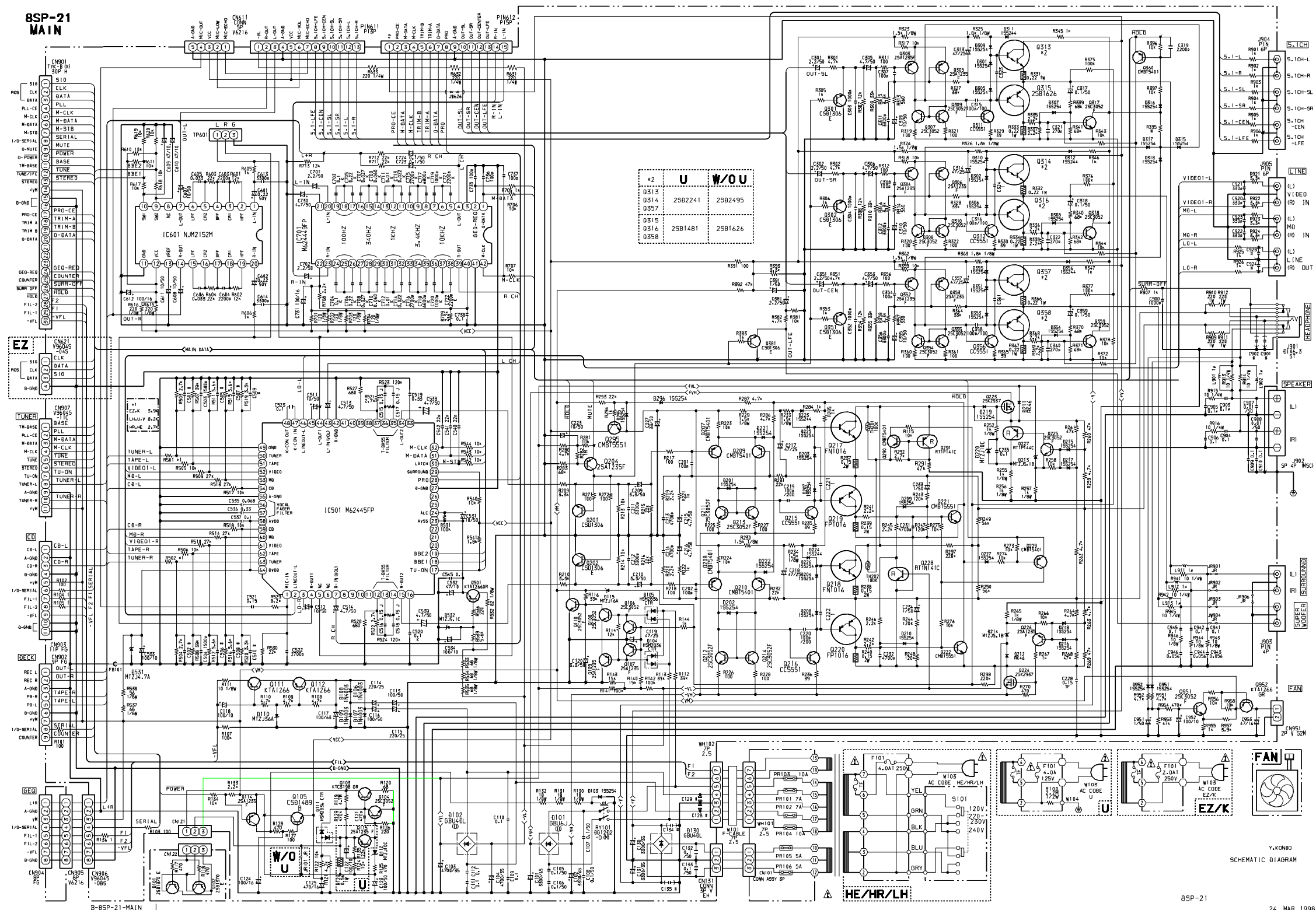

SCHEMATIC DIAGRAM - 2 (MX-NMT1000: FRONT)

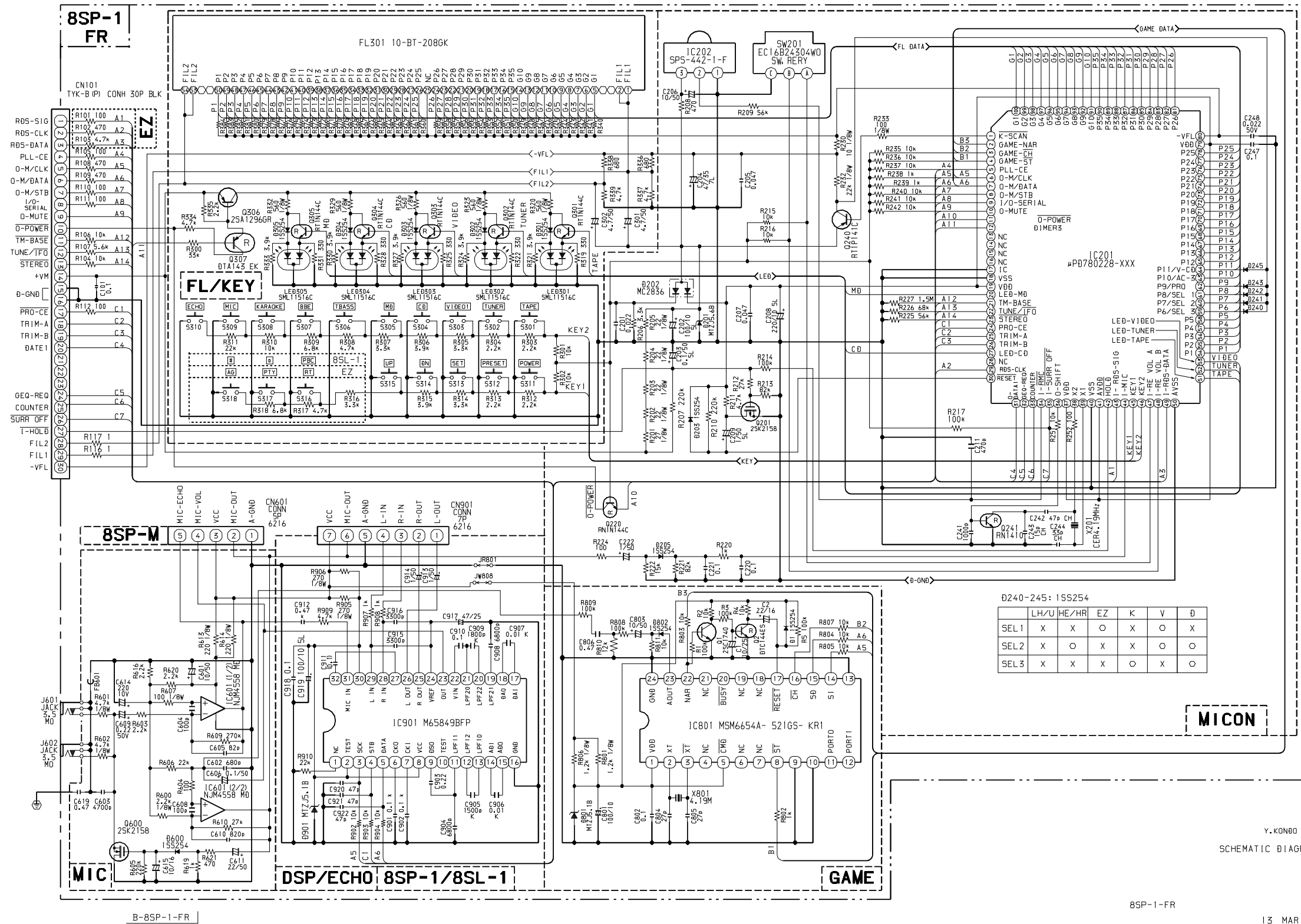

Y. KONDO
SCHEMATIC DIAGRAM

B-8SP-1-FR

8SP-1-FR

13 MAR 1998

SCHEMATIC DIAGRAM – 3 (MX-NMT1000: TUNER)

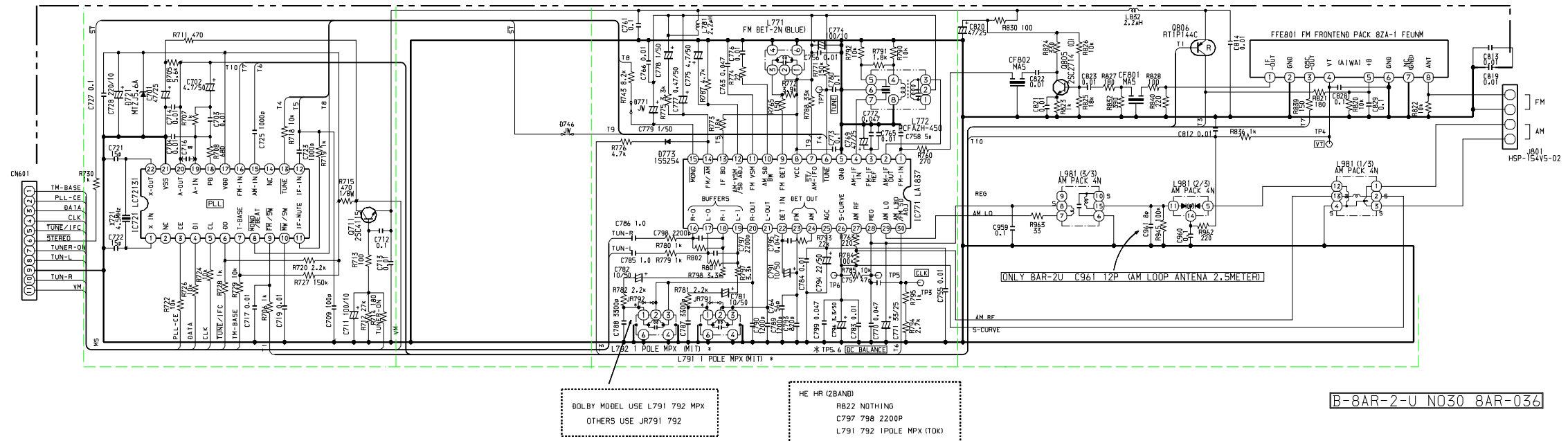

SCHEMATIC DIAGRAM - 4 (MX-NMT1000: PROLOGIC)

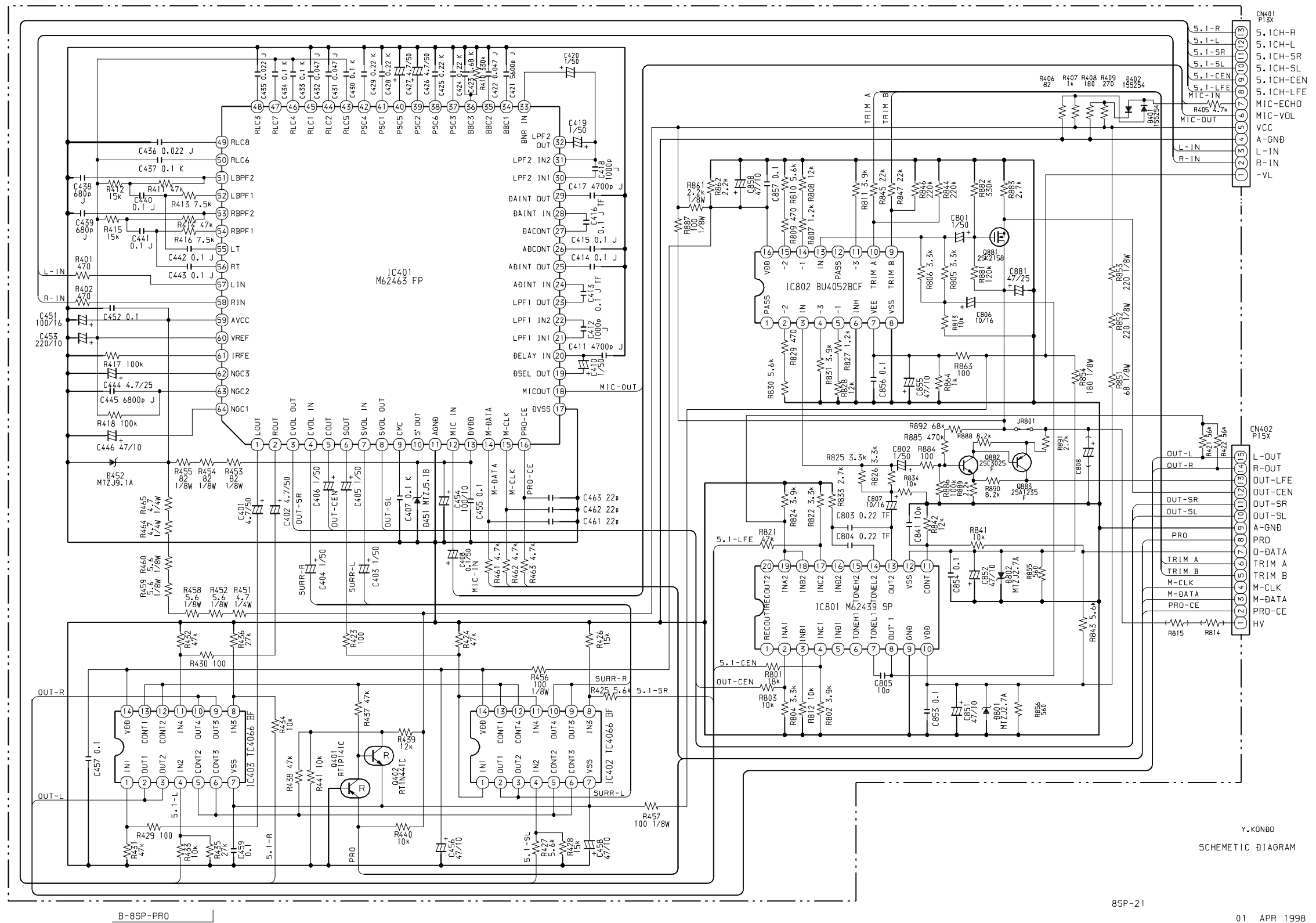

Y. KONDO
SCHEMATIC DIAGRAM

SCHMATIC DIAGRAM – 5 (MX-NMT1000: TUNER FRONT END)

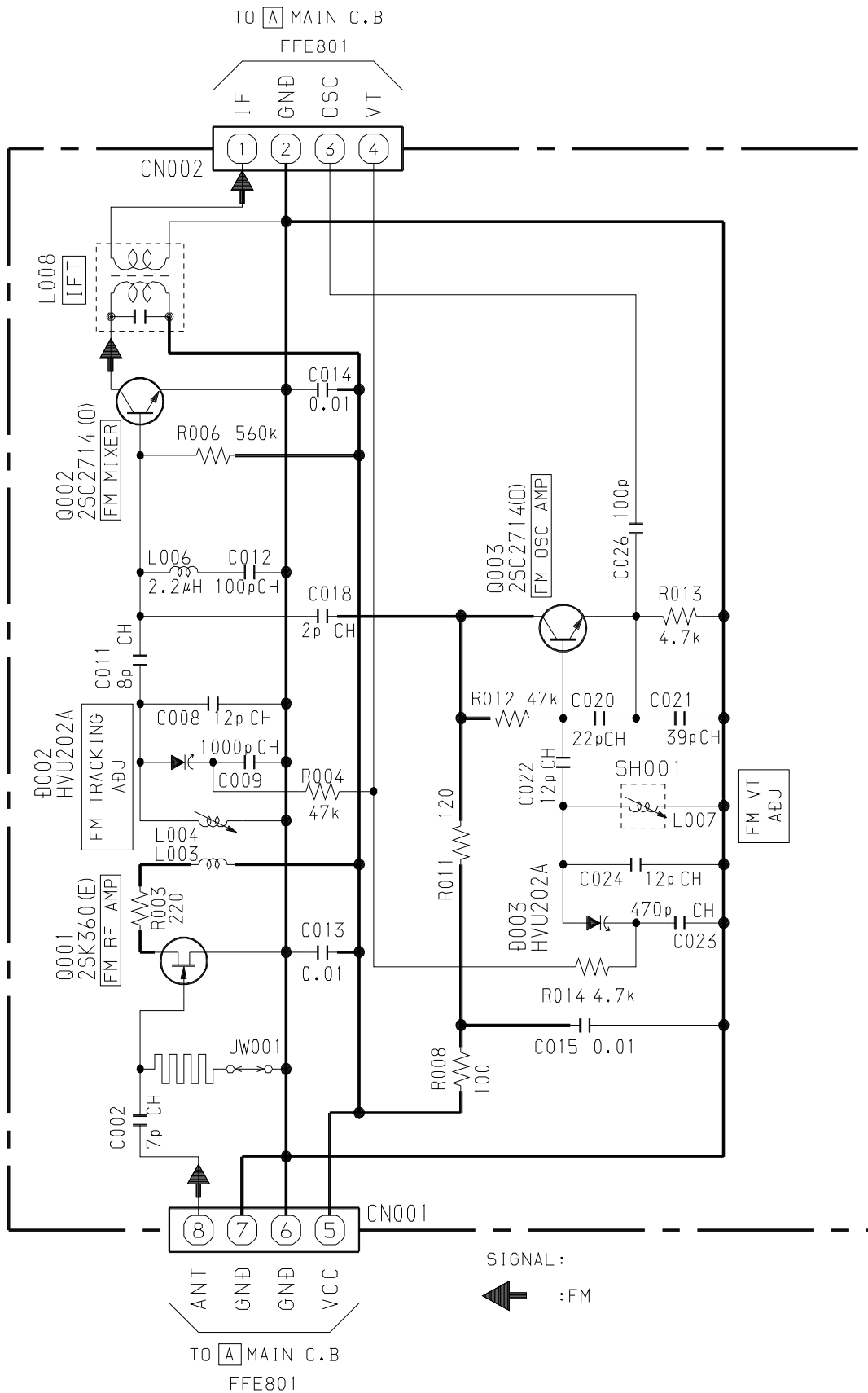

MECHANICAL PARTS LIST - 1 (MX-NMT1000)

NOTE: The characters in the suffix column indicate the part usage.

UXX.....A.....

REF.NO	PARTS NO.	DESCRIPTION	SUFFIX
	87-B00-002-010	BADGE,AIWA 30 ABS SIL	A.....
	88-SP1-002-010	CABI,STEEL	A.....
	88-SPM-001-010	CABI,FR
	88-SPM-003-010	PANEL,REAR USNM
	88-SPM-017-010	CABI,FR U	A.....
	88-SPM-022-010	PANEL,REAR HRJSNM
	88-SPM-024-010	PANEL,REAR KSNM
	88-SPM-030-010	PANEL,REAR USN	A.....
	88-SPM-034-010	PANEL,REAR KSN
	88-SPM-041-010	PANEL,REAR HES
	88-SU1-014-010	RING,FOOT	A.....
	88-SP1-005-010	KEY,FUN	A.....
	88-SP1-006-010	KEY,POWER	A.....
	88-SP1-007-010	KEY,BBE	A.....
	88-SP1-008-010	KEY,KARAOKE	A.....
	88-SP1-010-010	KNOB,RTRY VOL	A.....
	88-SP1-011-010	RING,VOL	A.....
	88-SP1-012-010	KEY,TUNING	A.....
	88-SP1-014-010	REFLECTOR,FUN	A.....
	88-SP1-015-010	KEY,ASSY FUN	A.....
	88-SP1-016-010	LENS,SENSOR
	88-SP1-004-010	WINDOW,DISPLAY	A.....
	87-085-213-010	FOOT,H12.5	A.....
	88-AR1-203-010	HLDR,TU	A.....
	88-SP1-208-010	COVER, FAN	A.....
	87-067-641-010	UTT2+3-8(W/O SLOT)BL	A.....
	87-067-688-010	BVTT+3-6	A.....
	87-067-703-010	TAPPING SCREW, BVT2+3-10	A.....
	87-067-822-010	BVT2+3-20 W/O SLOT	A.....
	87-078-019-010	S-SCREW,IT+4-6
	87-078-191-010	S-SCREW,IT+4-10	A.....
	87-591-094-410	TAPPING SCREW, QIT+3-6	A.....
	87-591-095-410	TAPPING SCREW, QIT+3-8 (GLD)	A.....
	87-085-185-010	BUSHING, AC CORD (E)
	87-085-189-010	BUSHING, CORD (U)	A.....
	88-905-281-110	FF-CABLE, 5P 1.25 280MM	A.....
	88-908-071-110	FF-CABLE, 8P 1.25 70MM	A.....
	88-911-121-110	FF-CABLE,11P 1.25	A.....
	0101 87-A90-796-010	FAN,F614R-12MC-15-300MM	A.....
F	101 87-035-364-010	FUSE, 1.6A 250V
F	101 87-035-367-010	FUSE, 3.15A 250V
F	101 87-035-488-010	FUSE,3.15A 125V D UL	A.....
PT	101 88-SPM-601-010	PT,U	A.....
PT	101 88-SPM-602-010	PT,HE
PT	101 88-SPM-606-010	PT,K
W	0 88-904-151-110	FF-CABLE, 4P 1.25 150MM
W	103 87-050-053-010	AC CORD ASSY,U-2	A.....
W	103 87-050-079-010	AC-CORD ASSY,E
	87-022-200-080	RESISTOR, METAL 0.56 1W	A.....
W	0 88-SP1-625-010	WIRE ASSY,1P (GRN)
W	0 88-SP1-626-010	WIRE ASSY,1P (YEL)
W	0 88-SP1-627-010	WIRE ASSY,1P (BLU)
W	0 88-SP1-628-010	WIRE ASSY,1P (BLK)
W	0 88-SP1-629-010	WIRE ASSY,1P (WHT)
W	101 85-NF5-628-010	F-CABLE 7P-2.5	A.....
	88-SP1-211-010	GUIDE,FUN	A.....
	88-SX1-203-010	GUIDE,FL	A.....

ELECTRICAL MAIN PARTS LIST - 1 (DX-NM1000)

NOTE: The characters in the suffix column indicate the part usage.

YUXX.....A.....

REF.NO	PARTS NO.	DESCRIPTION	SUFFIX
	88-SX1-202-010	GUIDE,LED OPE	AB.....
CN 101	87-099-194-010	CONN,6P 6216V	AB.....
LED 105	87-A40-521-040	LED,SEL6513C TP5 PGRN	AB.....
LED 106	87-A40-521-040	LED,SEL6513C TP5 PGRN	AB.....
LED 101	87-A40-521-040	LED,SEL6513C TP5 PGRN	AB.....
LED 104	87-A40-521-040	LED,SEL6513C TP5 PGRN	AB.....
LED 103	87-A40-521-040	LED,SEL6513C TP5 PGRN	AB.....
LED 102	87-A40-521-040	LED,SEL6513C TP5 PGRN	AB.....
S 102	87-A90-809-080	SW,TACT TSTA-2	AB.....
S 104	87-A90-809-080	SW,TACT TSTA-2	AB.....
S 103	87-A90-809-080	SW,TACT TSTA-2	AB.....
S 101	87-A90-809-080	SW,TACT TSTA-2	AB.....
S 105	87-A90-809-080	SW,TACT TSTA-2	AB.....
	88-SX1-203-010	GUIDE,FL	AB.....
	88-SX1-610-010	CORD,FG 11P	AB.....
C 5	87-010-190-080	S CHIP F 0.01	AB.....
C 6	87-010-196-080	CHIP CAPACITOR,0.1-25	AB.....
C 7	87-010-196-080	CHIP CAPACITOR,0.1-25	AB.....
C 4	87-010-197-080	CAP,CHIP 0.01 DM	AB.....
C 1	87-010-263-040	CAP,E 100-10	AB.....
C 8	87-010-312-080	C-CAP,S 15P-50 CH	AB.....
C 9	87-010-320-080	CHIP CAP 68P	AB.....
C 2	87-010-494-040	CAP,E 1-50 GAS	AB.....
C 3	87-010-496-040	CAP,E 3.3-50 GAS	AB.....
C 12	87-010-197-080	CAP,CHIP 0.01 DM	AB.....
C 13	87-010-246-040	CAP,E 47-35 SME	AB.....
C 10	87-010-316-080	C-CAP,S 33P-50 CH	AB.....
C 11	87-018-134-080	CAPACITOR,TC-U 0.01-16	AB.....
C 251	87-010-178-080	CHIP CAP 1000P	AB.....
C 255	87-010-178-080	CHIP CAP 1000P	AB.....
C 256	87-010-178-080	CHIP CAP 1000P	AB.....
C 253	87-010-178-080	CHIP CAP 1000P	AB.....
C 252	87-010-178-080	CHIP CAP 1000P	AB.....
C 254	87-010-178-080	CHIP CAP 1000P	AB.....
C 257	87-010-196-080	CHIP CAPACITOR,0.1-25	AB.....
CN 3	87-099-194-010	CONN,6P 6216V	AB.....
CN 303	87-099-015-010	CONN,13P 6216V	AB.....
CN 302	87-099-194-010	CONN,6P 6216V	AB.....
D 2	87-070-136-080	ZENER,MTZJ5.1B	AB.....
D 1	87-A40-470-080	DIODE,1SS254	AB.....
FB 304	87-008-474-080	F-BEAD,EMI BL02RN1	AB.....
FB 306	87-008-474-080	F-BEAD,EMI BL02RN1	AB.....
FB 307	87-008-474-080	F-BEAD,EMI BL02RN1	AB.....
FB 303	87-008-474-080	F-BEAD,EMI BL02RN1	AB.....
FB 305	87-008-474-080	F-BEAD,EMI BL02RN1	AB.....
FB 302	87-008-474-080	F-BEAD,EMI BL02RN1	AB.....
FB 301	87-008-474-080	F-BEAD,EMI BL02RN1	AB.....
FL 201	88-SX1-609-010	FL,6-BT-293GK	AB.....
IC 1	88-SX1-606-010	IC,UPD78045H-XXXX	AB.....
L 3	87-005-152-080	COIL,10UH	AB.....
L 2	87-005-152-080	COIL,10UH	AB.....
L 1	87-005-152-080	COIL,10UH	AB.....
L 5	87-005-152-080	COIL,10UH	AB.....
L 301	87-005-152-080	COIL,10UH	AB.....
LED 203	87-A40-446-040	LED,SLP-7131F-81H-S-T1 P-GRN	AB.....
LED 202	87-A40-446-040	LED,SLP-7131F-81H-S-T1 P-GRN	AB.....
LED 201	87-A40-446-040	LED,SLP-7131F-81H-S-T1 P-GRN	AB.....
LED 204	87-A40-446-040	LED,SLP-7131F-81H-S-T1 P-GRN	AB.....
Q 2	87-026-263-080	C-TR,RN1410	AB.....
Q 3	87-A30-074-080	C-TR,RT1P 141C	AB.....
Q 1	89-324-123-080	C-TR,2SC2412K S	AB.....
Q 302	87-A30-076-080	C-TR,2SC3052F	AB.....
Q 301	87-A30-076-080	C-TR,2SC3052F	AB.....
S 201	87-A90-809-080	SW,TACT TSTA-2	AB.....
S 202	87-A90-809-080	SW,TACT TSTA-2	AB.....
S 203	87-A90-809-080	SW,TACT TSTA-2	AB.....
S 204	87-A90-809-080	SW,TACT TSTA-2	AB.....
X 1	87-A70-075-080	VIB,CER 4.19MHZ CRHF	AB.....

SCHEMATIC DIAGRAM – 1 (DX-NM1000: MAIN / FRONT / KEY)

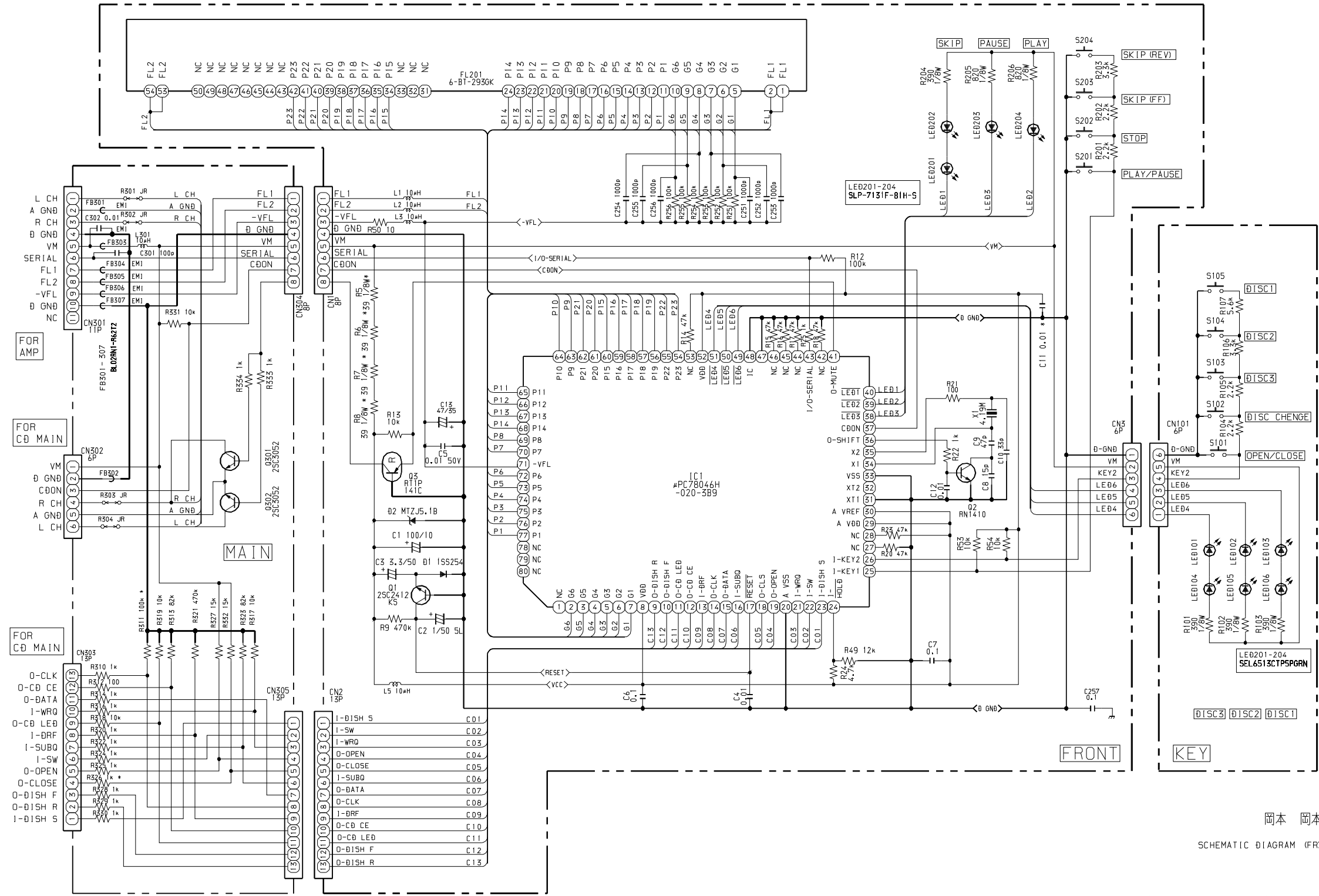

岡本 岡本
 SCHEMATIC DIAGRAM (FR)
 8SX-1-FR DX-SN1000
 01 APR 1998

MECHANICAL PARTS LIST - 1 (DX-NM1000)

NOTE: The characters in the suffix column indicate the part usage.

YUXX.....A.....

REF.NO	PARTS NO.	DESCRIPTION	SUFFIX	
	87-B00-002-010	BADGE,AIWA 30 ABS SIL	AB.....	
	88-SU1-014-010	RING,FOOT	AB.....	
	88-SX1-001-010	CABI,FR	.B.....	
	88-SX1-002-010	CABI,STEEL	AB.....	
	88-SX1-016-010	CABI,REAR YSNM	
	88-SX1-017-010	CABI,REAR YJSNM	
	88-SX1-018-010	CABI,REAR YUSNM	
	88-SX1-019-010	CABI,FR U	A.....	
	88-SX1-020-010	CABI,REAR YLSNM	
	88-SX1-021-010	CABI,REAR YS	
	88-SX1-022-010	CABI,REAR YLSN	.B.....	
	88-SX1-023-010	CABI,REAR YUSN	A.....	
	88-SX1-024-010	CABI,REAR YSN	
	88-SX1-005-010	KEY,OPEN	AB.....	
	88-SX1-006-010	KEY,OPE	AB.....	
	88-SX1-007-010	BTN,DISC 1	AB.....	
	88-SX1-008-010	BTN,DISC 2	AB.....	
	88-SX1-009-010	BTN,DISC 3	AB.....	
	88-SX1-010-010	KEY,ASSY DISC	AB.....	
	88-SX1-012-010	REFLECTOR,PLAY	AB.....	
	88-SX1-013-010	REFLECTOR,FF	AB.....	
	88-SX1-014-010	REFLECTOR,REW	AB.....	
	88-SX1-015-010	KEY,ASSY OPE	AB.....	
	88-SX1-201-010	GUIDE,LED DISC	AB.....	
	86-NF6-007-010	WINDOW,TOP	.B.....	
	86-NF6-101-010	WINDOW TOP UL	A.....	
	88-SX1-003-010	PANEL,TRAY	AB.....	
	88-SX1-004-010	WINDOW,DISPLAY	AB.....	
	84-ZG1-245-210	CAP,OPTICAL	AB.....	
	87-067-703-010	TAPPING SCREW, BVT2+3-10	AB.....	
	87-591-094-410	TAPPING SCREW, QIT+3-6	AB.....	
	88-906-201-110	FF-CABLE,6P 1.25	AB.....	
0003	88-906-481-110	FF-CABLE, 6P 1.25 480MM	AB.....	
W	2	88-913-121-110	FF-CABLE,P1.25	AB.....
W	1	88-SX1-202-010	GUIDE,LED OPE	AB.....
	88-SX1-203-010	GUIDE,FL	AB.....	
	88-SX1-610-010	CORD,FG 11P	AB.....	

ELECTRICAL MAIN PARTS LIST - 1/2 (FX-NM1000)

NOTE: The characters in the suffix column indicate the part usage.

MUSNXX.....A.....

REF.NO	PARTS NO.	DESCRIPTION	SUFFIX	
		88-SW1-201-010	GUIDE,LED OPE	AB.....
D	702	87-002-787-080	LED,SEL 6215S RED	AB.....
D	712	87-070-197-080	LED,SLP7118C-51-S-T1	AB.....
D	711	87-070-197-080	LED,SLP7118C-51-S-T1	AB.....
D	713	87-070-197-080	LED,SLP7118C-51-S-T1	AB.....
S	701	87-A90-809-080	SW,TACT TSTA-2	AB.....
S	704	87-A90-809-080	SW,TACT TSTA-2	AB.....
S	703	87-A90-809-080	SW,TACT TSTA-2	AB.....
S	702	87-A90-809-080	SW,TACT TSTA-2	AB.....
S	714	87-A90-809-080	SW,TACT TSTA-2	AB.....
S	711	87-A90-809-080	SW,TACT TSTA-2	AB.....
S	715	87-A90-809-080	SW,TACT TSTA-2	AB.....
S	712	87-A90-809-080	SW,TACT TSTA-2	AB.....
S	713	87-A90-809-080	SW,TACT TSTA-2	AB.....
C	603	87-010-101-080	CAP, ELECT 220-16	AB.....
C	609	87-010-196-080	CHIP CAPACITOR,0.1-25	AB.....
C	605	87-010-198-080	CAP, CHIP 0.022	AB.....
C	604	87-010-237-080	CAP, ELECT 1000-16V	AB.....
C	607	87-010-263-080	CAP, ELECT 100-10V	AB.....
C	602	87-010-381-080	CAP, ELECT 330-16V	AB.....
C	606	87-010-546-080	CAP, ELECT 0.33-50V	AB.....
C	601	87-015-997-010	CAP, ELECT 2200UF-16V	AB.....
C	614	87-010-197-080	CAP, CHIP 0.01 DM	AB.....
C	611	87-010-312-080	C-CAP,S 15P-50 CH	AB.....
C	612	87-010-316-080	C-CAP,S 33P-50 CH	AB.....
C	610	87-010-320-080	CHIP CAP 68P	AB.....
C	613	87-010-404-080	CAP, ELECT 4.7-50V	AB.....
D	603	87-017-931-080	ZENER,MTZJ5.6B	AB.....
D	602	87-017-931-080	ZENER,MTZJ5.6B	AB.....
D	604	87-A40-470-080	DIODE,1SS254	AB.....
FB	301	87-008-372-080	FILTER, EMI BL OIRNI	AB.....
FB	603	87-008-372-080	FILTER, EMI BL OIRNI	AB.....
FB	602	87-008-372-080	FILTER, EMI BL OIRNI	AB.....
FB	601	87-008-372-080	FILTER, EMI BL OIRNI	AB.....
IC	601	88-SW1-608-010	IC,M38503M2	AB.....
L	601	87-005-130-080	COIL,10UH	AB.....
L	603	87-005-130-080	COIL,10UH	AB.....
Q	603	87-026-263-080	C-TR,RN1410	AB.....
Q	609	87-A30-071-080	C-TR,RT1N 144C	AB.....
Q	605	87-A30-073-080	C-TR,RT1N 141C	AB.....
Q	604	87-A30-073-080	C-TR,RT1N 141C	AB.....
Q	606	87-A30-074-080	C-TR,RT1P 141C	AB.....
Q	608	87-A30-076-080	C-TR,2SC3052F	AB.....
Q	607	87-A30-076-080	C-TR,2SC3052F	AB.....
Q	602	89-318-155-080	TR,2SC1815 (0.4W)	AB.....
Q	601	89-318-155-080	TR,2SC1815 (0.4W)	AB.....
Q	610	87-A30-076-080	C-TR,2SC3052F	AB.....
W	601	88-SW1-607-010	CORD,FG9P	AB.....
X	601	87-A70-120-080	VIB,8.00MHZ	AB.....
C	307	87-010-196-080	CHIP CAPACITOR,0.1-25	AB.....
C	302	87-010-318-080	C-CAP,S 47P-50 CH	AB.....
C	301	87-010-318-080	C-CAP,S 47P-50 CH	AB.....
C	306	87-012-145-080	CAP, CHIP S 270P CH	AB.....
C	305	87-012-145-080	CAP, CHIP S 270P CH	AB.....
C	303	87-012-157-080	C-CAP,S 330P-50 CH	AB.....
C	304	87-012-157-080	C-CAP,S 330P-50 CH	AB.....
C	316	87-010-178-080	CHIP CAP 1000P	AB.....
C	315	87-010-178-080	CHIP CAP 1000P	AB.....
C	314	87-010-180-080	C-CER 1500P	AB.....
C	313	87-010-180-080	C-CER 1500P	AB.....
C	311	87-010-198-080	CAP, CHIP 0.022	AB.....
C	312	87-010-198-080	CAP, CHIP 0.022	AB.....
C	319	87-012-141-080	CHIP-CAPACITOR,0.22-16F	AB.....
C	317	87-012-142-080	CAP, S 0.33-16	AB.....
C	318	87-012-142-080	CAP, S 0.33-16	AB.....
C	324	87-010-260-080	CAP, ELECT 47-25V	AB.....
C	325	87-010-370-080	CAP,E 330-6.3 SME	AB.....
C	328	87-010-404-080	CAP, ELECT 4.7-50V	AB.....
C	327	87-010-404-080	CAP, ELECT 4.7-50V	AB.....
C	322	87-012-141-080	CHIP-CAPACITOR,0.22-16F	AB.....
C	321	87-012-141-080	CHIP-CAPACITOR,0.22-16F	AB.....
C	320	87-012-141-080	CHIP-CAPACITOR,0.22-16F	AB.....
C	339	87-010-196-080	CHIP CAPACITOR,0.1-25	AB.....
C	337	87-010-196-080	CHIP CAPACITOR,0.1-25	AB.....
C	332	87-010-196-080	CHIP CAPACITOR,0.1-25	AB.....
C	335	87-010-401-080	CAP, ELECT 1-50V	AB.....
C	336	87-010-401-080	CAP, ELECT 1-50V	AB.....
C	340	87-010-196-080	CHIP CAPACITOR,0.1-25	AB.....
C	359	87-010-183-080	C-CAP,S 2700P-50 B	AB.....
C	358	87-010-183-080	C-CAP,S 2700P-50 B	AB.....
C	357	87-010-197-080	CAP, CHIP 0.01 DM	AB.....
C	356	87-010-260-080	CAP, ELECT 47-25V	AB.....
C	351	87-012-140-080	CAP 470P	AB.....
C	352	87-012-140-080	CAP 470P	AB.....
C	360	87-010-183-080	C-CAP,S 2700P-50 B	AB.....
C	371	87-010-179-080	CAP,CHIP S B1200P	AB.....

ELECTRICAL MAIN PARTS LIST - 2/2 (FX-NM1000)

C	373	87-010-179-080	CAP,CHIP S B1200P	AB.....
C	372	87-010-179-080	CAP,CHIP S B1200P	AB.....
C	374	87-010-179-080	CAP,CHIP S B1200P	AB.....
C	378	87-010-196-080	CHIP CAPACITOR,0.1-25	AB.....
C	370	87-010-196-080	CHIP CAPACITOR,0.1-25	AB.....
C	376	87-010-545-080	CAP, ELECT 0.22-50V	AB.....
C	375	87-010-545-080	CAP, ELECT 0.22-50V	AB.....
C	388	87-010-154-080	CAP CHIP 10P	AB.....
C	385	87-010-184-080	CHIP CAPACITOR 3300P(K)	AB.....
C	386	87-010-196-080	CHIP CAPACITOR,0.1-25	AB.....
C	381	87-010-197-080	CAP, CHIP 0.01 DM	AB.....
C	383	87-010-197-080	CAP, CHIP 0.01 DM	AB.....
C	382	87-010-318-080	C-CAP,S 47P-50 CH	AB.....
C	384	87-010-402-080	CAP, ELECT 2.2-50V	AB.....
D	352	87-A40-269-080	C-DIODE,MC2836	AB.....
D	351	87-A40-470-080	DIODE,1SS254	AB.....
IC	302	87-A20-355-010	IC,CXA1553P	AB.....
IC	301	87-A20-455-010	IC,HA12211	AB.....
L	302	87-A50-049-010	COIL,TRAP 85K(COI)	AB.....
L	301	87-A50-049-010	COIL,TRAP 85K(COI)	AB.....
L	351	87-007-342-010	COIL,OSC 85K BIAS	AB.....
Q	358	87-026-610-080	TR,KTC3198GR	AB.....
Q	357	87-026-610-080	TR,KTC3198GR	AB.....
Q	359	87-026-610-080	TR,KTC3198GR	AB.....
Q	355	87-A30-074-080	C-TR,RT1P 141C	AB.....
Q	354	87-A30-087-080	C-FET,2SK2158	AB.....
Q	353	87-A30-087-080	C-FET,2SK2158	AB.....
Q	351	87-A30-087-080	C-FET,2SK2158	AB.....
Q	360	87-A30-073-080	C-TR,RT1N 141C	AB.....
Q	382	87-A30-076-080	C-TR,2SC3052F	AB.....
Q	381	87-A30-076-080	C-TR,2SC3052F	AB.....
SFR	302	87-A90-636-080	SFR,33K H RH0638C LG	AB.....
SFR	303	87-A90-636-080	SFR,33K H RH0638C LG	AB.....
SFR	301	87-A90-636-080	SFR,33K H RH0638C LG	AB.....
SFR	304	87-A90-636-080	SFR,33K H RH0638C LG	AB.....
SFR	306	87-A90-637-080	SFR,47K H RH0638C LG	AB.....
SFR	305	87-A90-637-080	SFR,47K H RH0638C LG	AB.....
SFR	351	87-A90-637-080	SFR,47K H RH0638C LG	AB.....
SFR	352	87-A90-637-080	SFR,47K H RH0638C LG	AB.....
D	501	87-A40-269-080	C-DIODE,MC2836	AB.....
Q	506	87-A30-073-080	C-TR,RT1N 141C	AB.....
Q	504	87-A30-073-080	C-TR,RT1N 141C	AB.....
Q	502	87-A30-085-070	C-TR,CSA1362GR	AB.....
Q	503	87-A30-085-070	C-TR,CSA1362GR	AB.....
Q	501	89-112-965-080	TR,2SA1296 (0.75W)	AB.....

SCHEMATIC DIAGRAM - 1 (FX-NM1000: MAIN / FRONT)

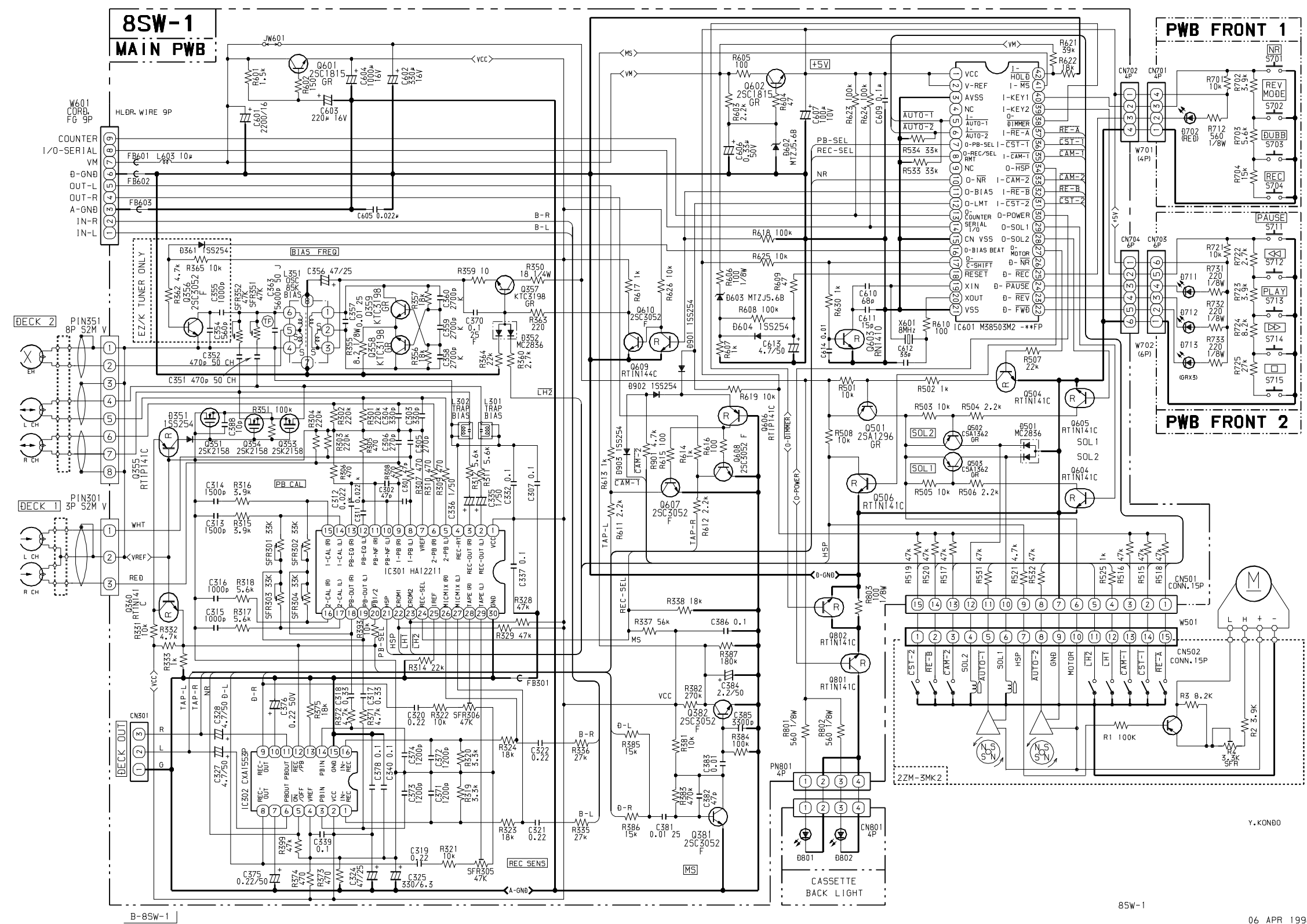

8SW-1

06 APR 1998

MECHANICAL PARTS LIST - 1 (FX-NM1000)

NOTE: The characters in the suffix column indicate the part usage.

MUSNXX.....A.....

REF.NO	PARTS NO.	DESCRIPTION	SUFFIX	
	87-B00-002-010	BADGE,AIWA 30 ABS SIL	AB.....	
	88-SU1-014-010	RING,FOOT	AB.....	
	88-SW1-001-010	CABI,FR	.B.....	
	88-SW1-002-010	CABI,STEEL	AB.....	
	88-SW1-003-010	BOX,CASS 1	.B.....	
	88-SW1-004-010	BOX,CASS 2	AB.....	
	88-SW1-007-010	CABI,REAR YSNM	
	88-SW1-016-010	CABI,REAR YJSNM	
	88-SW1-017-010	CABI,REAR YUSNM	
	88-SW1-018-010	CABI,FR U	A.....	
	88-SW1-021-010	CABI,REAR YLSNM	
	88-SW1-022-010	BOX,CASS 1 U	A.....	
	88-SW1-023-010	CABI,REAR YS	
	88-SW1-024-010	CABI,REAR YLSN	.B.....	
	88-SW1-025-010	CABI,REAR YUSN	A.....	
	88-SW1-026-010	CABI,REAR YSN	
	88-SW1-008-010	KEY,OPE	AB.....	
	88-SW1-009-010	KEY,REC	AB.....	
	88-SW1-010-010	REFLECTOR,PLAY	AB.....	
	88-SW1-012-010	REFLECTOR,PAUSE	AB.....	
	88-SW1-013-010	REFLECTOR,REC	AB.....	
	88-SW1-014-010	KEY,ASSY OPE	AB.....	
	88-SW1-015-010	KEY,ASSY REC	AB.....	
	81-532-080-010	LABEL, CASS. COMPT	AB.....	
	88-SW1-005-010	WINDOW,CASS 1	AB.....	
	88-SW1-006-010	WINDOW,CASS 2	AB.....	
	88-SW1-019-010	PLATE,CASS 1	AB.....	
	88-SW1-020-010	PLATE,CASS 2	AB.....	
	86-NF5-618-110	CONN ASSY,8P RPB	AB.....	
	82-NF5-218-010	SPR-T,EJECT 1 (SIN)	AB.....	
	82-NF5-219-010	SPR-T,EJECT 2 (SIN)	AB.....	
	82-NF5-229-010	PLATE,LOCK	AB.....	
	86-NF9-224-010	SPR-C,LOCK	AB.....	
	87-NF4-216-010	HLDR,LOCK 1	AB.....	
	87-NF4-217-010	HLDR,LOCK 2	AB.....	
	87-NF8-220-010	DMPR,150	AB.....	
	87-067-641-010	UTT2+3-8(W/O SLOT)BL	AB.....	
	87-067-703-010	TAPPING SCREW, BVT2+3-10	AB.....	
W	501	88-915-161-110	FF-CABLE, 15P 1.25	AB.....
W	701	88-904-331-110	FF-CABLE, 4P 1.25 330MM	AB.....
W	702	88-906-301-110	FF-CABLE,6P-1.25	AB.....
		88-SW1-201-010	GUIDE,LED OPE	AB.....
W	601	88-SW1-607-010	CORD,FG9P	AB.....

TAPE MECHANISM PARTS LIST - 1 (FX-NM1000)

REF.NO.	PARTNO.	KANRI NO	DESCRIPTION	REF.NO.	PARTNO.	KANRI NO	DESCRIPTION
1	82-ZM3-301-519		CHAS ASSY,M2	36	82-ZM1-236-019		CAPSTAN N 2-41.5
2	82-ZM1-258-110		SPR-T,PINCH L	37	82-ZM1-239-019		CAPSTAN N 2.2-41.7
3	82-ZM1-341-110		LVR ASSY,PINCH L2	38	82-ZM1-322-019		SPR-T,FR60
4	82-ZM1-333-010		PLATE, LINK 2	39	82-ZM1-220-219		GEAR, IDLER
5	82-ZM1-266-11K		LVR, DIR	40	82-ZM3-616-019		RING MAGNET 4
6	82-ZM1-214-010		SPR-T, DIR	41	82-ZM1-216-31K		GEAR, REEL
7	82-ZM1-206-81K		CHAS, HEAD	42	87-A90-319-010		HEAD, PH HADKH2 FPC
8	82-ZM3-307-019		CUSH-G, DIA3.7-8-3.2	42	87-A90-320-010		HEAD, RPH HADKH5 FPC
9	82-ZM1-269-219		SPR-T, BRG	43	82-ZM1-225-21K		GEAR, FR
10	82-ZM1-219-119		SPR-T, LINK	44	82-ZM1-226-019		GEAR, REW
11	82-ZM1-210-119		GEAR, H T	45	82-ZM3-333-310		SLIP DISK ASSY 2
12	82-ZM1-213-019		SPR-T, HEAD	46	82-ZM1-338-010		BELT FR4
13	82-ZM1-207-619		GUIDE, TAPE	47	82-ZM1-349-110		FLY-WHL, R W(DECK 2)
14	86-ZM4-206-010		S-SCREW, AZIMUTH	47	82-ZM3-338-110		FLY-WHL, R3 W(DECK 1)
15	82-ZM1-314-119		PLATE, HEAD	48	82-ZM1-348-010		FLY-WHL, L W(DECK 2)
16	82-ZM1-208-119		HLDR, HEAD	48	82-ZM1-348-010		FLY-WHL, L W(DECK 1)
17	82-ZM1-218-019		SPR-E, HB	49	82-ZM3-329-210		BELT, SBU R2
18	82-ZM1-263-110		LVR, EJECT L (DECK 1)	50	82-ZM1-245-210		HLDR, IC
18	82-ZM1-264-010		LVR, EJECT R (DECK 2)	51	87-045-347-019		MOT, SHU2L 70(M1)
19	82-ZM1-222-21K		LVR, PLAY	52	82-ZM3-221-010		PULLEY, MOT 2M
20	82-ZM1-217-319		REEL TABLE	53	82-ZM1-288-019		SH, 1.63-3.2-0.5 SLT
21	82-ZM1-244-510		SPR-C, BT	54	80-ZM6-243-019		SH, 1.75-3.6-0.5 SLT
22	82-ZM1-285-310		SPR-C, BT L	55	82-ZM3-335-210		PULLEY, COUPLER M3(DECK 1)
23	82-ZM1-257-019		SPR-T, CAS	56	82-ZM3-337-010		BELT, SBU MOT 2
24	82-ZM1-241-319		LVR, MC	57	82-ZM3-339-010		SHAFT, COUPLER N3(DECK 1)
25	82-ZM1-242-019		LVR, CAS	58	86-ZM1-206-010		BELT, MAIN L
26	82-ZM1-243-019		LVR, STOP	59	82-ZM3-340-010		SH, BELT D2
27	82-ZM1-344-110		LVR ASSY, PINCH R2	A	85-ZM3-202-010		S-SCREW, TG
28	82-ZM1-259-110		SPR-T, PINCH R	B	80-ZM6-207-019		V+1.6-7
29	82-ZM1-240-11K		LVR, REC (DECK 2)	C	82-ZM3-318-019		S-SCRW MOTOR M2
31	82-ZM1-255-319		SPR-E, LVR DIR	D	87-B10-043-010		W-P, 0.99-4-0.25 SLT
32	82-ZM3-305-01K		GEAR, CAM M2	E	82-ZM3-334-010		PW, 2.16-6-0.4
33	82-ZM1-227-21K		LVR, TRIG				
34	82-ZM3-306-11K		LVR, FR M2				
35	82-ZM1-265-119		SPR-E, TRIG				

ELECTRICAL MAIN PARTS LIST - 1 (GE-NMT1000)

NOTE: The characters in the suffix column indicate the part usage.

MUSNXX.....A.....

REF.NO	PARTS NO.	DESCRIPTION	SUFFIX	
C	301	87-010-196-080	CHIP CAPACITOR,0.1-25	A.....
S	301	87-A90-095-080	SW,TACT EVQ11G04M	A.....
S	306	87-A90-095-080	SW,TACT EVQ11G04M	A.....
S	307	87-A90-095-080	SW,TACT EVQ11G04M	A.....
S	304	87-A90-095-080	SW,TACT EVQ11G04M	A.....
S	309	87-A90-095-080	SW,TACT EVQ11G04M	A.....
S	302	87-A90-095-080	SW,TACT EVQ11G04M	A.....
S	305	87-A90-095-080	SW,TACT EVQ11G04M	A.....
S	308	87-A90-095-080	SW,TACT EVQ11G04M	A.....
S	303	87-A90-792-010	SW,RTRY EC12E12244 ENCODER	A.....
S	313	87-A90-095-080	SW,TACT EVQ11G04M	A.....
S	310	87-A90-095-080	SW,TACT EVQ11G04M	A.....
S	312	87-A90-095-080	SW,TACT EVQ11G04M	A.....
S	311	87-A90-095-080	SW,TACT EVQ11G04M	A.....
C	109	87-010-196-080	CHIP CAPACITOR,0.1-25	A.....
C	108	87-010-196-080	CHIP CAPACITOR,0.1-25	A.....
C	105	87-010-312-080	C-CAP,S 15P-50 CH	A.....
C	107	87-010-316-080	C-CAP,S 33P-50 CH	A.....
C	106	87-010-320-080	CHIP CAP 68P	A.....
C	103	87-010-497-040	CAP,E 4.7-35 GAS	A.....
C	101	87-010-550-040	CAP,E 100-6.3 GAS	A.....
C	110	87-012-368-080	C-CAP,S 0.1-50 F	A.....
C	120	87-010-196-080	CHIP CAPACITOR,0.1-25	A.....
D	101	87-070-136-080	ZENER,MTZJ5.1B	A.....
D	102	87-A40-337-080	ZENER,MTZJ 6.8B	A.....
D	103	87-A40-470-080	DIODE,1SS254	A.....
FB	101	87-008-372-080	FILTER, EMI BL OIRNI	A.....
IC	101	88-SU1-603-010	IC,LC866448W-	A.....
L	102	87-005-130-080	COIL,10UH	A.....
L	103	87-005-130-080	COIL,10UH	A.....
L	101	87-005-152-080	COIL,10UH	A.....
L	104	87-005-152-080	COIL,10UH	A.....
Q	101	87-026-263-080	C-TR,RN1410	A.....
W	101	88-SU1-608-010	CORD,FG 8P	A.....
X	101	87-A70-070-080	VIB,CER 5.76MHZ CRHF	A.....
		88-SU1-201-010	GUIDE,FL	A.....
C	203	87-010-497-040	CAP,E 4.7-35 GAS	A.....
C	204	87-012-369-080	C-CAP,S 0.047-50F	A.....
FL	201	88-SU1-605-010	FL,BJ624GK	A.....
LED	206	87-017-350-080	LED,SEL1550CM	A.....
LED	208	87-017-350-080	LED,SEL1550CM	A.....
LED	202	87-017-350-080	LED,SEL1550CM	A.....
LED	209	87-017-350-080	LED,SEL1550CM	A.....
LED	204	87-017-350-080	LED,SEL1550CM	A.....
LED	203	87-017-350-080	LED,SEL1550CM	A.....
LED	207	87-017-350-080	LED,SEL1550CM	A.....
LED	201	87-017-350-080	LED,SEL1550CM	A.....
LED	205	87-017-350-080	LED,SEL1550CM	A.....
LED	210	87-017-350-080	LED,SEL1550CM	A.....
LED	211	87-017-350-080	LED,SEL1550CM	A.....
LED	212	87-017-350-080	LED,SEL1550CM	A.....
LED	215	87-070-201-080	LED,SLP9118C-51-S-T1	A.....
LED	218	87-070-201-080	LED,SLP9118C-51-S-T1	A.....
LED	214	87-070-201-080	LED,SLP9118C-51-S-T1	A.....
LED	219	87-070-201-080	LED,SLP9118C-51-S-T1	A.....
LED	216	87-070-201-080	LED,SLP9118C-51-S-T1	A.....
LED	213	87-070-201-080	LED,SLP9118C-51-S-T1	A.....
LED	217	87-070-201-080	LED,SLP9118C-51-S-T1	A.....
LED	220	87-070-201-080	LED,SLP9118C-51-S-T1	A.....
Q	206	87-A30-073-080	C-TR,RT1N 141C	A.....
Q	207	87-A30-073-080	C-TR,RT1N 141C	A.....
C	403	87-010-196-080	CHIP CAPACITOR,0.1-25	A.....
C	405	87-010-196-080	CHIP CAPACITOR,0.1-25	A.....
C	402	87-010-196-080	CHIP CAPACITOR,0.1-25	A.....
C	404	87-010-196-080	CHIP CAPACITOR,0.1-25	A.....
C	401	87-010-196-080	CHIP CAPACITOR,0.1-25	A.....
C	406	87-010-196-080	CHIP CAPACITOR,0.1-25	A.....
C	407	87-012-158-080	C-CAP,S 390P-50 CH	A.....
IC	401	87-A20-083-010	IC,BA3835S	A.....

SCHEMATIC DIAGRAM – 1 (GE-NMT1000: MAIN)

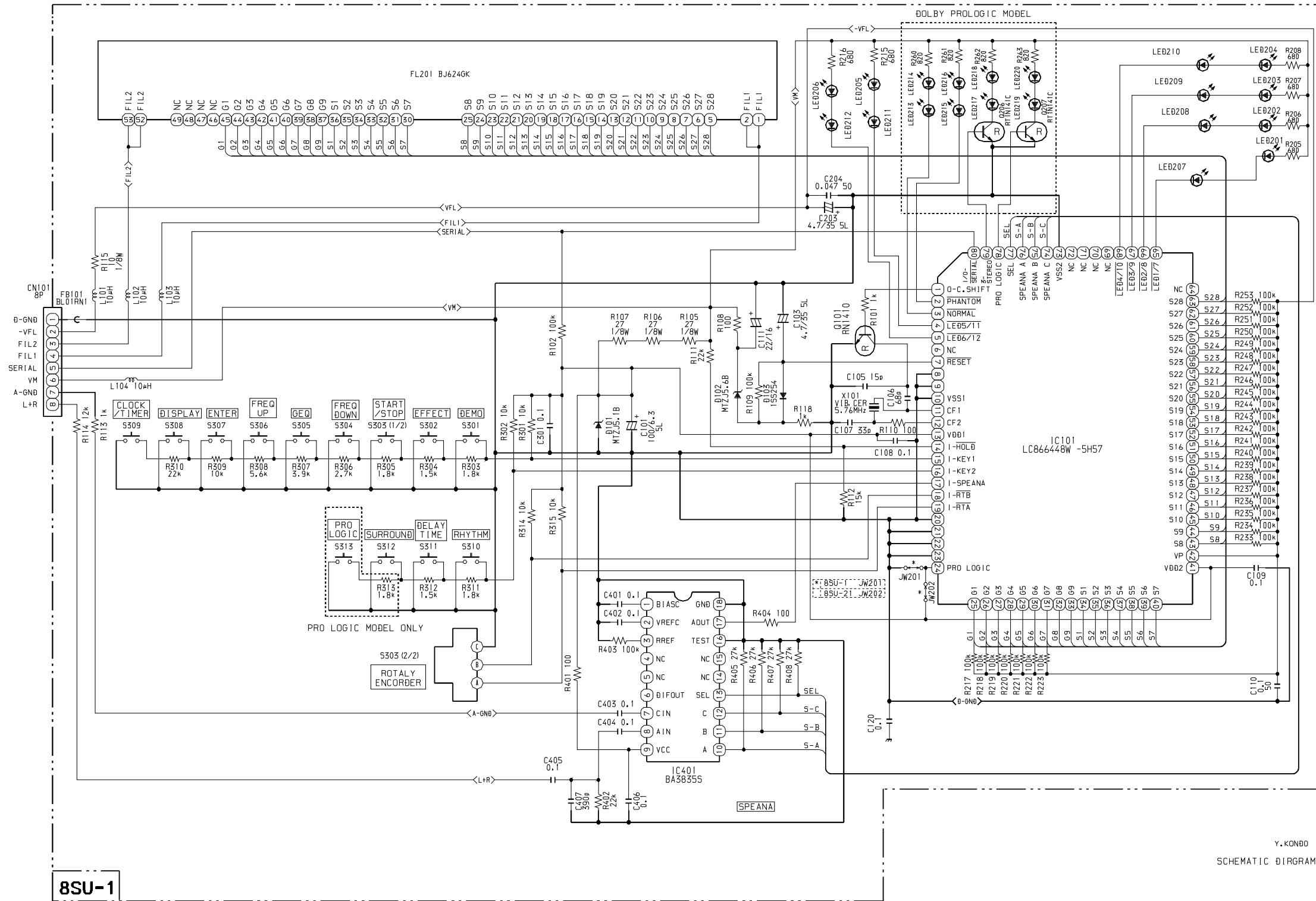

Y. KONDO
SCHEMATIC DIAGRAM

MECHANICAL PARTS LIST - 1 (GE-NMT1000)

NOTE: The characters in the suffix column indicate the part usage.

REF.NO	PARTS NO.	DESCRIPTION	SUFFIX
	87-B00-002-010	BADGE,AIWA 30 ABS SIL	A.....
	88-SU1-002-010	CABI,STEEL	A.....
	88-SU1-005-010	REFLECTOR,JOG	A.....
	88-SU1-006-010	PANEL,JOG	A.....
	88-SU1-014-010	RING,FOOT	A.....
	88-SUM-001-010	CABI,FR
	88-SUM-003-010	CABI,REAR YSNM
	88-SUM-017-010	CABI,FR U	A.....
	88-SUM-021-010	CABI,REAR YJSNM
	88-SUM-022-010	CABI,REAR YUSNM
	88-SUM-024-010	CABI,REAR YS
	88-SUM-026-010	CABI,REAR YUSN	A.....
	88-SUM-027-010	CABI,REAR YSN
	88-SU1-007-010	KNOB,RTRY JOG	A.....
	88-SU1-008-010	KEY,GEQ	A.....
	88-SU1-009-010	KEY,TIMER	A.....
	88-SU1-010-010	KEY,ENTER	A.....
	88-SU1-012-010	KEY,DEMO	A.....
	88-SUM-011-010	KEY,PRO	A.....
	88-SU1-004-010	WINDOW,DISPLAY	A.....
	88-SUM-202-010	GUIDE,PRO	A.....
	87-067-641-010	UTT2+3-8(W/O SLOT)BL	A.....
	87-067-703-010	TAPPING SCREW, BVT2+3-10	A.....
W 101	88-SU1-608-010	CORD,FG 8P	A.....
	88-SU1-201-010	GUIDE,FL	A.....

ACCESSORIES / PACKAGE LIST - 1

NOTE: The characters in the suffix column indicate the part usage.

REF.NO	PARTS NO.	DESCRIPTION	SUFFIX
			UXX.....A.....
	88-SPM-901-010	IB,H(ECA)I
	88-SPM-903-010	IB,U(ESF)M	A.....
	88-SPM-905-010	IB,K(E)M
	88-SPM-911-010	IB,H(ECA)M
	87-006-225-010	AM LOOP ANT NC2	A.....
	87-043-095-010	WIRE ANTENNA
	87-043-106-010	WIRE, FM ANT (Z)
	87-043-115-010	ANT,FEEDER FM	A.....
	87-A90-312-010	PLUG,CONVERSION WTN-1157R1
	87-NFR-610-010	RC UNIT,RC-7AS09	A.....
ANT 0	87-006-269-010	AM LOOP ANT (UN)

サービス技術ニュース	
番号	連絡内容
G- -	
G- -	
G- -	

アイワ株式会社
AIWA CO.,LTD.

9420208,9630472,9630466

Tokyo Japan