

XP-ZV700/ZV701/ZV702

SERVICE MANUAL

Ver. 1.0 2005.01

AEP Model
XP-ZV700/ZV701/ZV702

E Model
XP-ZV700/ZV701



Photo: XP-ZV700

US and foreign patents licensed from Dolby Laboratories.

- SonicStage and SonicStage logo are trademarks or registered trademarks of Sony Corporation.
- OpenMG, Net MD, ATRAC, ATRAC3plus and their logos are trademarks of Sony Corporation.
- "WALKMAN" is a registered trademark of Sony Corporation to represent Headphone Stereo products. **WALKMAN** is a trademark of Sony Corporation.
- Microsoft, Windows, Windows NT and Windows Media are trademarks or registered trademarks of Microsoft Corporation in the United States and /or other countries.
- IBM and PC/AT are registered trademarks of International Business Machines Corporation. Macintosh is a trademark of Apple Computer, Inc. in the United States and/or other countries.
- Pentium is a trademark or a registered trademark of Intel Corporation.
- All other trademarks and registered trademarks are trademarks or registered trademarks of their respective holders. TM and © marks are omitted in this manual.
- CD and music-related data from Gracenote, Inc., copyright © 2000-2003 Gracenote. Gracenote CDDb® Client software, copyright 2000-2003 Gracenote. This product and service may practice one or more of the following U.S. Patents: #5,987,525; #6,061,680; #6,154,773; #6,161,132; #6,230,192; #6,230,207; #6,240,459; #6,330,593, and other patents issued or pending. Gracenote and CDDb are registered trademarks of Gracenote. The Gracenote logo and logotype, the Gracenote CDDb logo, and the "Powered by Gracenote" logo are trademarks of Gracenote.

Program © 2001, 2002, 2003, 2004 Sony Corporation
Documentation © 2004 Sony Corporation

Model Name Using Similar Mechanism	NEW
CD Mechanism Type	CDM-3325ERV
Optical Pick-Up Name	DAX-25EV

SPECIFICATIONS

System

Compact disc digital audio system

Laser diode properties

Material: GaAlAs

Wavelength: $\lambda = 770 - 800 \text{ nm}$

Emission duration: Continuous

Laser output: Less than 44.6 μW

(This output is the value measured at a distance of 200 mm from the objective lens surface on the optical pick-up block with 7 mm aperture.)

D-A conversion

1-bit quartz time-axis control

Frequency response

20 - 20 000 Hz $\pm 1 \text{ dB}$ (measured by JEITA)

Output (at 3 V input level)

Headphones (stereo minijack)

Approx. 5 mW + Approx. 5 mW at 16 Ω

(Approx. 1.5 mW + Approx. 1.5 mW at 16 Ω)*

*For the customers in AEP model

Power requirements

- LR6 (size AA) battery: 1.5 V DC \times 1

- Sony NH-7WMAA rechargeable battery: 1.2 V DC \times 1*

- Sony NH-AA-B2D rechargeable battery: 2,300 mAh

- AC power adaptor (DC IN 3 V jack): 100 - 240 V, 50/60 Hz

* Except ZV700: AEP model. For the area code of the model you purchased, check the upper left side of the bar code on the package.

Battery life ¹⁾

When using one alkaline battery ²⁾

	E•A•S•S GP	
	"EASS GP 1"	"EASS GP 2"
Audio CD	22	20
ATRAC CD ³⁾	41	38
MP3 CD ⁴⁾	26	24

When using one NH-7WMAA rechargeable battery (charged for about 5 hours ^{5) 6)})

	E•A•S•S GP	
	"EASS GP 1"	"EASS GP 2"
Audio CD	10	9
ATRAC CD ³⁾	17	15
MP3 CD ⁴⁾	12	11

1) Measured value using the JEITA (Japan Electronics and Information Technology Industries Association)

Playing time shown is approximate hours, when you use the player on a flat and stable surface and "POWER SAVE" is set to "ON".

This value varies depending on how the player is used.

2) When using a Sony LR6 (SG) alkaline battery (produced in Japan)

– Continued on next page –

PORTABLE CD PLAYER

9-879-387-01
2005A0578-1
© 2005.01

Sony Corporation
Personal Audio Company
Published by Sony Engineering Corporation



- 3)Recorded at 48kbps
- 4)Recorded at 128kbps
- 5)Charging time varies depending on how the rechargeable battery is used.
- 6)Except ZV700: AEP model

Operating temperature

5°C - 35°C (41°F - 95°F)

Dimensions (w/h/d) (excluding projecting parts and controls)

Approx. 137.8 × 25.0 × 137.8 mm (5 1/2 × 1 × 5 1/2 in.)

Mass (excluding accessories)

Approx. 179 g (6.4 oz.)

Supplied Accessories

AC power adaptor (ZV700: AEP model*)

Earphones (ZV700: E18 and ZV701: E18 models only*)

Earphones (Other models)

Remote (ZV701: E18 and ZV702 models only*)

Clamp filter (ZV700: AEP model only*)

Rechargeable battery (ZV701: E18 model only*)

Battery carrying case (ZV701: E18 model only*)

CD-ROM (SonicStage)

Operating instructions

Installation/Operating Guide

* For the area code of the model you purchased, check the upper left side of the bar code on the package.

Design and specifications are subject to change without notice.

• Abbreviation

E18: Singapore model

TABLE OF CONTENTS

1. SERVICING NOTES	3
2. GENERAL	5
3. DISASSEMBLY	
3-1. Disassembly Flow	6
3-2. Cabinet (Upper) Assy, Cabinet (Lower)	6
3-3. JACK Board, Optical Pick-up Assy (CDM-3325ERV) ...	7
3-4. SWITCH Board	7
4. DIAGRAMS	
4-1. Printed Wiring Board – EGL Board –	9
4-2. Schematic Diagram – EGL Board –	10
4-3. Printed Wiring Board – JACK Board (Component Side) –	11
4-4. Printed Wiring Board – JACK Board (Conductor Side) –	12
4-5. Schematic Diagram – JACK Board –	13
4-6. Printed Wiring Board – SWITCH Board –	14
4-7. Schematic Diagram – SWITCH Board –	15
5. EXPLODED VIEWS	
5-1. Cabinet (Upper) Section	23
5-2. Cabinet (Upper) Assy Section	24
5-3. Cabinet (Lower) Section	25
5-4. Optical Pick-up Section (CDM-3325ERV)	26
6. ELECTRICAL PARTS LIST	27

Notes on the AC power adaptor

- Disconnect all power sources when the player is not to be used for a long time.
- Use only the AC power adaptor supplied. If your player is not supplied with the one, use an AC-E30HG AC power adaptor (not available in Australian and Argentina). If you use any other AC power adaptor, malfunction may occur.



Polarity of the plug

- Do not touch the AC power adaptor with wet hands.
- Connect the AC power adaptor to an easily accessible AC outlet. Should you notice an abnormality in the AC power adaptor, disconnect it from the AC outlet immediately.

Notes on chip component replacement

- Never reuse a disconnected chip component.
- Notice that the minus side of a tantalum capacitor may be damaged by heat.

Flexible Circuit Board Repairing

- Keep the temperature of the soldering iron around 270 °C during repairing.
- Do not touch the soldering iron on the same conductor of the circuit board (within 3 times).
- Be careful not to apply force on the conductor when soldering or unsoldering.

CAUTION

Use of controls or adjustments or performance of procedures other than those specified herein may result in hazardous radiation exposure.

SAFETY-RELATED COMPONENT WARNING!!

COMPONENTS IDENTIFIED BY MARK \triangle OR DOTTED LINE WITH MARK \triangle ON THE SCHEMATIC DIAGRAMS AND IN THE PARTS LIST ARE CRITICAL TO SAFE OPERATION. REPLACE THESE COMPONENTS WITH SONY PARTS WHOSE PART NUMBERS APPEAR AS SHOWN IN THIS MANUAL OR IN SUPPLEMENTS PUBLISHED BY SONY.

SECTION 1 SERVICING NOTES

NOTES ON HANDLING THE OPTICAL PICK-UP BLOCK OR BASE UNIT

The laser diode in the optical pick-up block may suffer electrostatic break-down because of the potential difference generated by the charged electrostatic load, etc. on clothing and the human body. During repair, pay attention to electrostatic break-down and also use the procedure in the printed matter which is included in the repair parts.
The flexible board is easily damaged and should be handled with care.

NOTES ON LASER DIODE EMISSION CHECK

The laser beam on this model is concentrated so as to be focused on the disc reflective surface by the objective lens in the optical pick-up block. Therefore, when checking the laser diode emission, observe from more than 30 cm away from the objective lens.

UNLEADED SOLDER

Boards requiring use of unleaded solder are printed with the lead-free mark (LF) indicating the solder contains no lead.
(Caution: Some printed circuit boards may not come printed with the lead free mark due to their particular size)

LF: LEAD FREE MARK

Unleaded solder has the following characteristics.

- Unleaded solder melts at a temperature about 40 °C higher than ordinary solder.
Ordinary soldering irons can be used but the iron tip has to be applied to the solder joint for a slightly longer time.
Soldering irons using a temperature regulator should be set to about 350 °C.
Caution: The printed pattern (copper foil) may peel away if the heated tip is applied for too long, so be careful!
- Strong viscosity
Unleaded solder is more viscous (sticky, less prone to flow) than ordinary solder so use caution not to let solder bridges occur such as on IC pins, etc.
- Usable with ordinary solder
It is best to use only unleaded solder but unleaded solder may also be added to ordinary solder.

OPERATION CHECK WHEN THE LID IS OPEN

In performing the repair with the power supplied to the set, removing the JACK board causes the set to be disabled.
In such a case, make a solder bridge to short SL501 (OPEN) on the JACK board in advance.

– JACK Board (Component Side) –

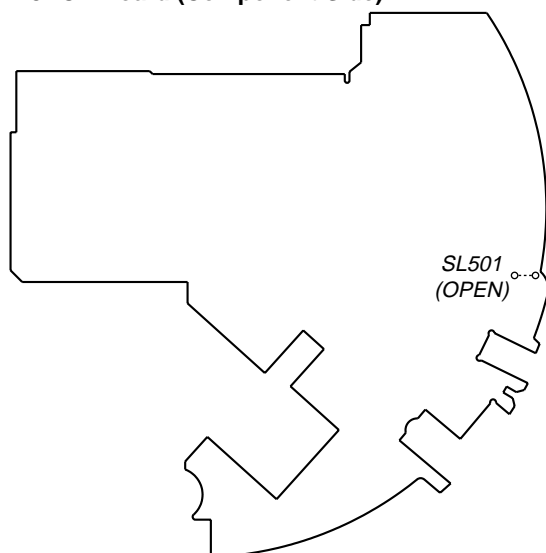

LASER DIODE AND FOCUS SEARCH OPERATION CHECK

During normal operation of the equipment, emission of the laser diode is prohibited unless the upper lid is closed while turning ON the S502. (push switch type)
The following checking method for the laser diode is operable.

- **Method:**
Emission of the laser diode is visually checked.
 1. Open the upper lid.
 2. With a disc not set, turn on the S502 with a screwdriver having a thin tip as shown in Fig. 1.
 3. Press the **▶|| ENTER** button.
 4. Observing the objective lens, check that the laser diode emits light.
When the laser diode does not emit light, automatic power control circuit or optical pick-up is faulty.
In this operation, the objective lens will move up and down 2 times along with inward motion for the focus search.

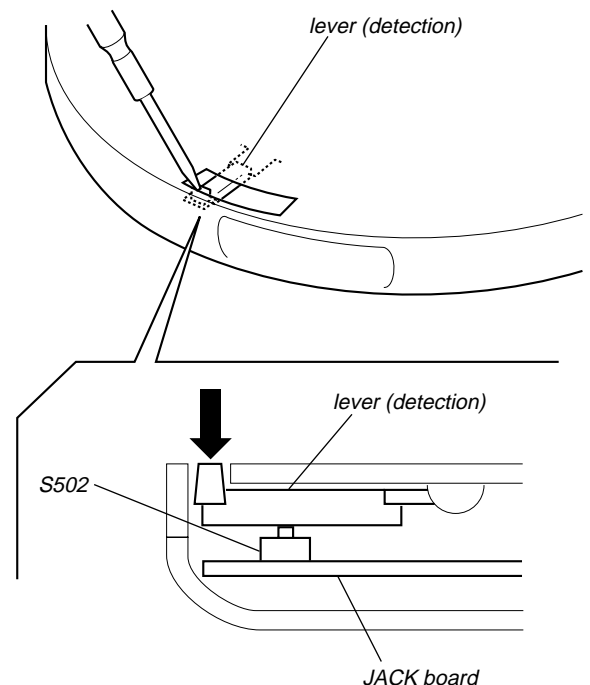

Fig. 1 Method to push the S502

NOTES ON REPLACEMENT OF CSP (CHIP SIZE PACKAGE) IC

Replacement of CXR711260-212H2 (IC603) used in this set requires a special tool.

Providing the required system environment

System requirements

The following system environment is required in order to use the SonicStage Ver. 2.3.

Computer	IBM PC/AT or Compatible <ul style="list-style-type: none"> • CPU: Pentium II 400 MHz or higher (Pentium III 450 MHz or higher is recommended.) • Hard disk drive space: 200 MB or more (1.5 GB or more is recommended) (The amount space will vary according to Windows version and the number of music files stored on the hard disk.) • RAM: 64 MB or more (128 MB or more is recommended) Others <ul style="list-style-type: none"> • CD drive (capable of digital playback by WDM) • Sound Board • USB port (supports USB (previously USB 1.1))
Operating System	Factory installed: Windows XP Media Center Edition 2005/Windows XP Media Center Edition 2004/Windows XP Media Center Edition/Windows XP Professional/Windows XP Home Edition/Windows 2000 Professional/Windows Millennium Edition/Windows 98 Second Edition
Display	High Color (16 bit) or higher, 800 × 600 dots or better (1024 × 768 dots or better is recommended)
Others	<ul style="list-style-type: none"> • Internet access: for Web registration, EMD services and CDDB • Windows Media Player (version 7.0 or higher) installed for playing WMA files

This software is not supported by the following environments:

- OSs other than the indicated above
- Personally constructed PCs or operating systems
- An environment that is an upgrade of the original manufacturer-installed operating system
- Multi-boot environment
- Multi-monitor environment
- Macintosh

Notes

- We do not ensure trouble-free operation on all computers that satisfy the system requirements.
- The NTFS format of Windows XP/Windows 2000 Professional can be used only with the standard (factory) settings.
- We do not ensure trouble-free operation of the system suspend, sleep, or hibernation function on all computers.
- For Windows 2000 Professional users, install Service Pack 3 or later before using the software.

COLOR VARIATION

Model	Destination	BLACK	WHITE
XP-ZV700	AEP	●	●
	E	●	●
XP-ZV701	AEP	●	●
	E	●	●
XP-ZV702	AEP	●	●

SECTION 2 GENERAL

This section is extracted from instruction manual.

Guide to Parts and Controls

CD player

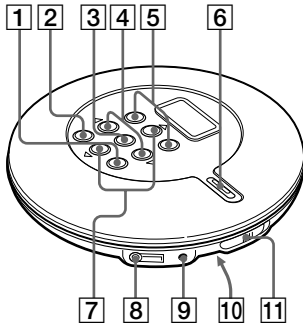

Remote (ZV702 and ZV701: E18 models only*)

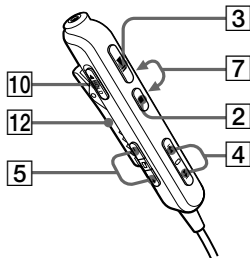

* For the area code of the model you purchased, check the upper left side of the bar code on the package.

- Abbreviation
E18: Singapore model

Display

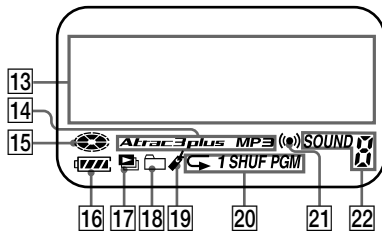

- 1 SEARCH button
- 2 CD player:
ZV700: AEP model:
■ button
Other models:
■/CHG button
26)
Remote:
■ button
- 3 CD player:
▶|| (play/pause)*/ENTER button
Remote:
▶|| (play/pause)* button
- 4 ◀◀/▶▶ buttons
- 5 ◻ +/- buttons
- 6 DISPLAY/MENU button
21, 23, 25)
- 7 CD player:
VOL +/-•Δ/▽ buttons
VOL +/-
Δ/▽
Remote:
VOL +/-
- 8 ◻ (headphones) jack
- 9 DC IN 3 V jack
- 10 HOLD switch (on the back of the CD player)
- 11 OPEN switch
- 12 Clip

* This button has a tactile dot.

- 13 Character information display
- 14 Atrac3plus/MP3 indicator
- 15 Disc indicator
- 16 Battery indicator
- 17 Play list indicator
- 18 Group indicator
- 19 Bookmark indicator
- 20 Play mode indicator
- 21 Timer indicator
- 22 Sound indicator

SECTION 3 DISASSEMBLY

• This set can be disassembled in the order shown below.

3-1. DISASSEMBLY FLOW

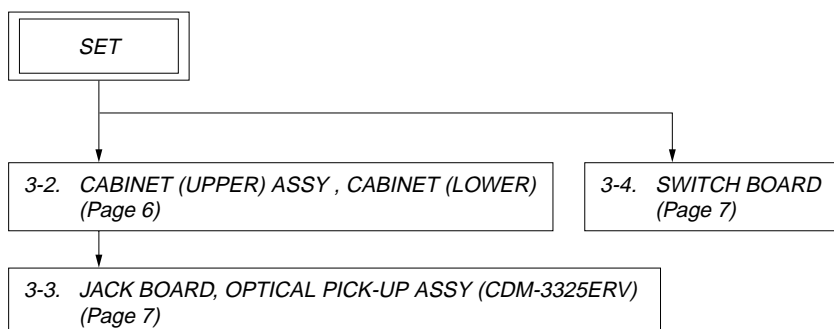

Note: Follow the disassembly procedure in the numerical order given.

3-2. CABINET (UPPER) ASSY, CABINET (LOWER)

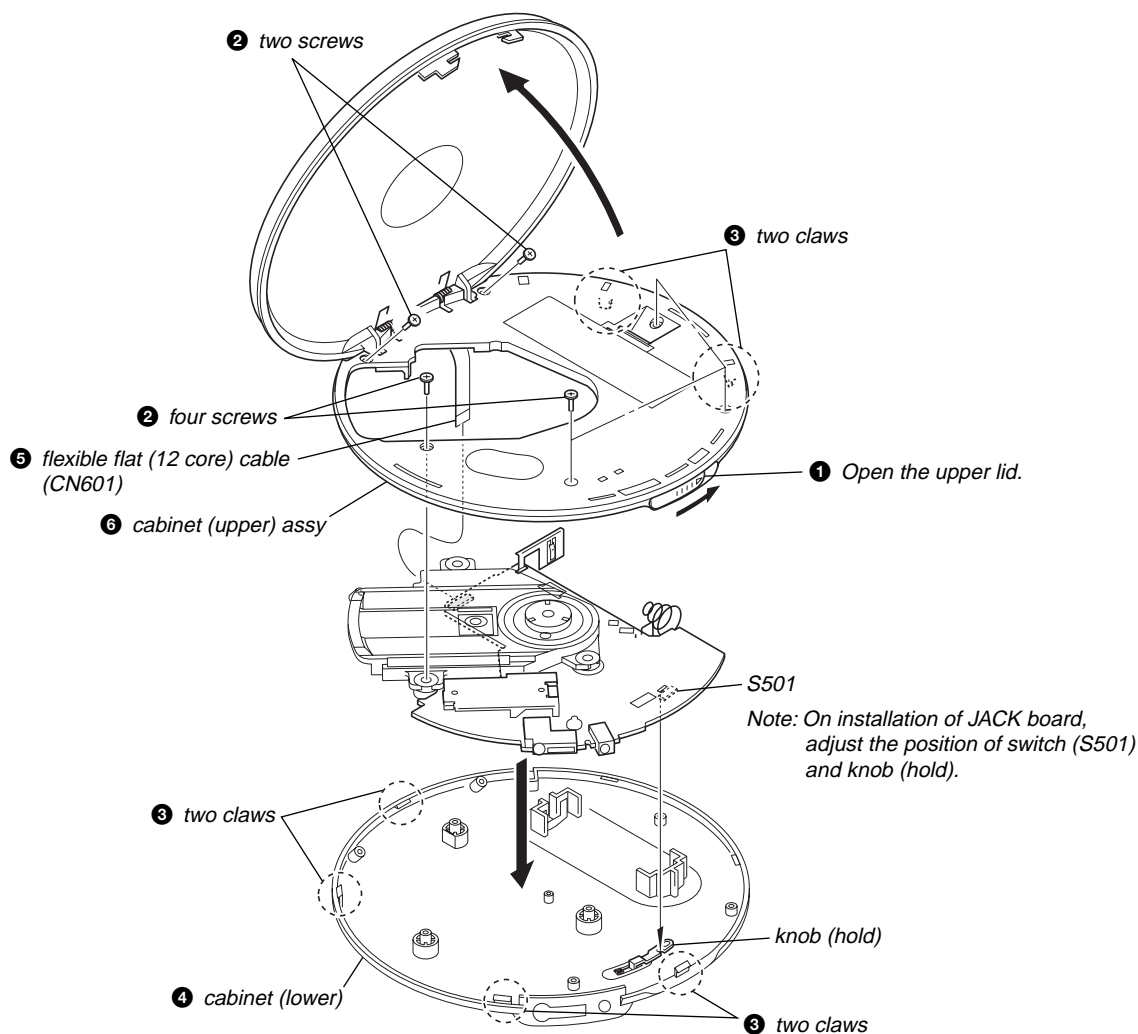

3-3. JACK BOARD, OPTICAL PICK-UP ASSY (CDM-3325ERV)

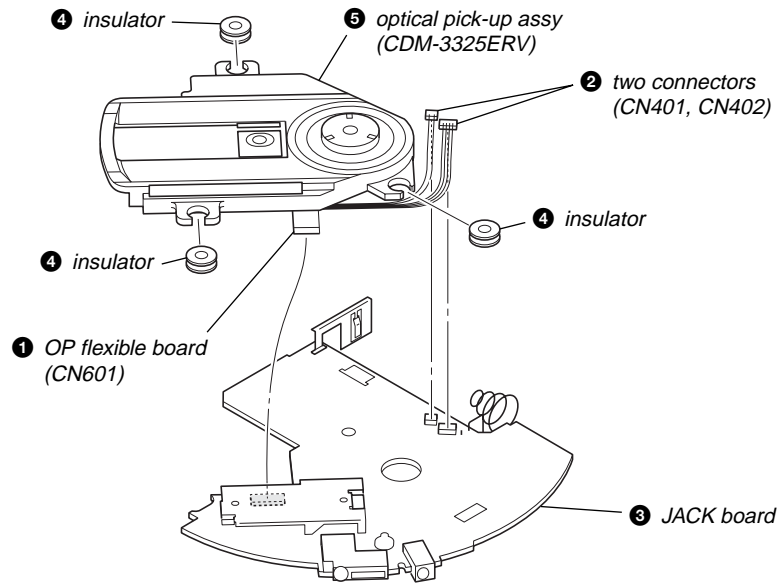



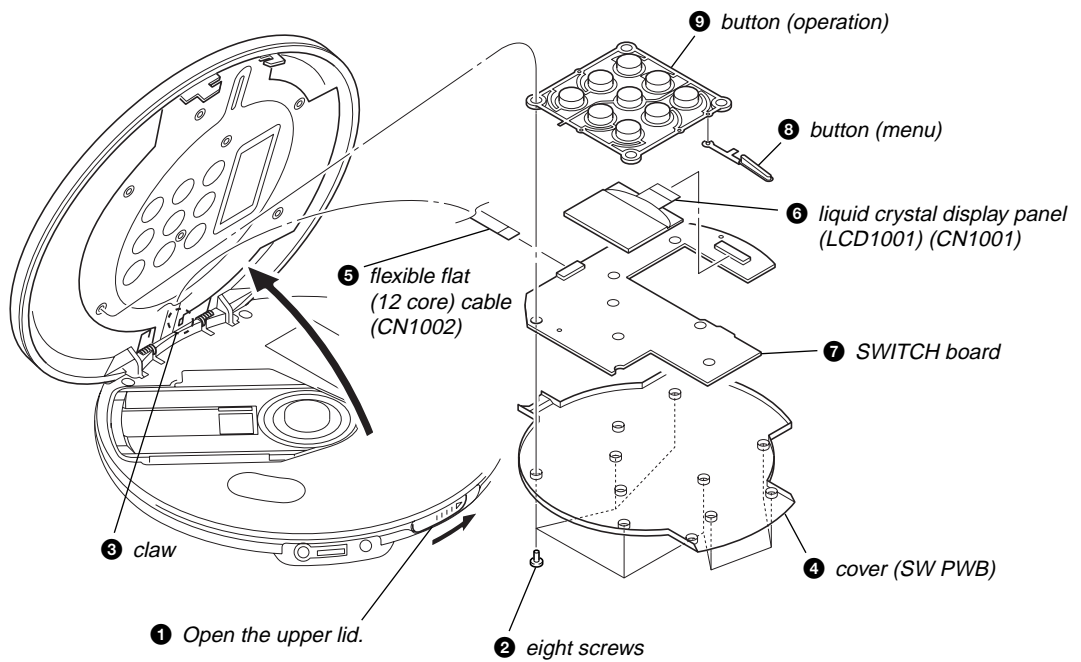

3-4. SWITCH BOARD



SECTION 4 DIAGRAMS

• **Note for Printed Wiring Boards and Schematic Diagrams**

Note on Printed Wiring Boards.

-  : parts extracted from the component side.
-  : parts extracted from the conductor side.
-  : Through hole.
-  : internal component
-  : Pattern from the side which enables seeing.
(The other layers' patterns are not indicated.)

Caution:
 Pattern face side: Parts on the pattern face side seen from the pattern face are indicated.
 (Conductor Side)
 Parts face side: Parts on the parts face side seen from the parts face are indicated.
 (Component Side)

Caution:
 Pattern face side: Parts on the pattern face side seen from the pattern face are indicated.
 (Side B)
 Parts face side: Parts on the parts face side seen from the parts face are indicated.
 (Side A)

- EGL board is multi-layer printed board. However, the patterns of intermediate-layer have not been included in the diagram.



* Replacement of IC603 used in this set requires a special tool.

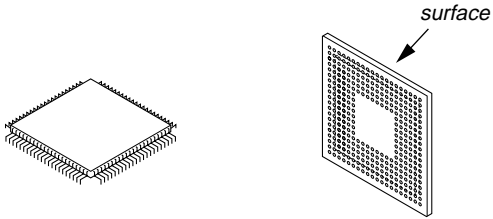

• Lead Layouts





Lead layout of conventional IC CSP (chip size package)

Note on Schematic Diagrams.

- All capacitors are in μF unless otherwise noted. (p: pF) 50 WV or less are not indicated except for electrolytics and tantalums.
- All resistors are in Ω and $1/4\text{W}$ or less unless otherwise specified.
-  : internal tolerance.
-  : panel designation.

Note: The components identified by mark  or dotted line with mark  are critical for safety. Replace only with part number specified.

-  : B+ Line.
- Power voltage is dc 1.5 V and fed with regulated dc power supply from battery terminal.
- Voltages and waveforms are dc with respect to ground under no-signal conditions.
no mark : CD PLAY
- Voltages are taken with a VOM (Input impedance 10 M Ω). Voltage variations may be noted due to normal production tolerances.
- Waveforms are taken with a oscilloscope. Voltage variations may be noted due to normal production tolerances.
- Circled numbers refer to waveforms.
- Signal path.
 : CD PLAY

* Replacement of IC603 used in this set requires a special tool.

4-1. PRINTED WIRING BOARD – EGL BOARD –  :Uses unleaded solder.

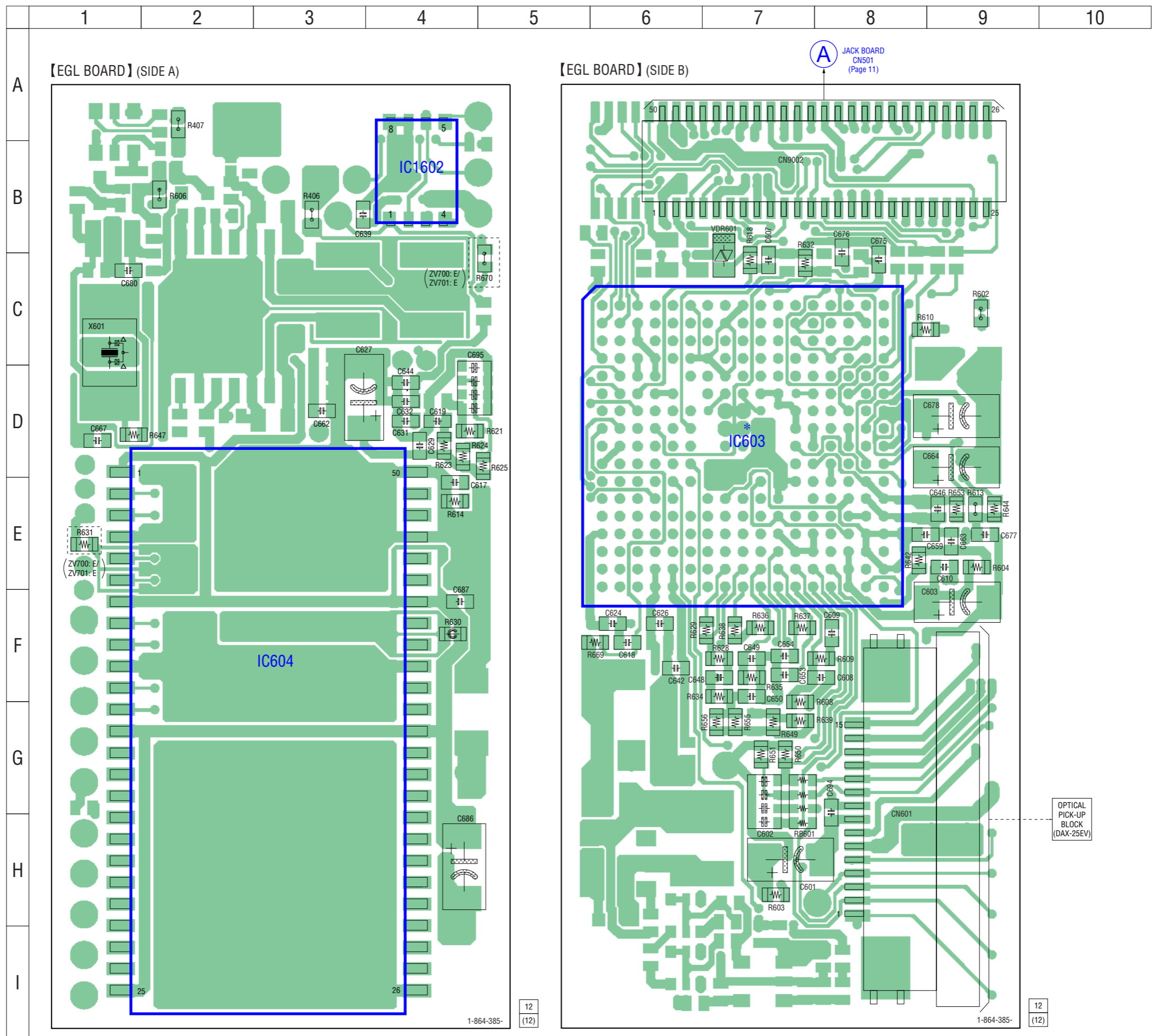

4-2. SCHEMATIC DIAGRAM – EGL BOARD – • See page 16 for Waveforms. • See page 16 for IC Pin Function Description.

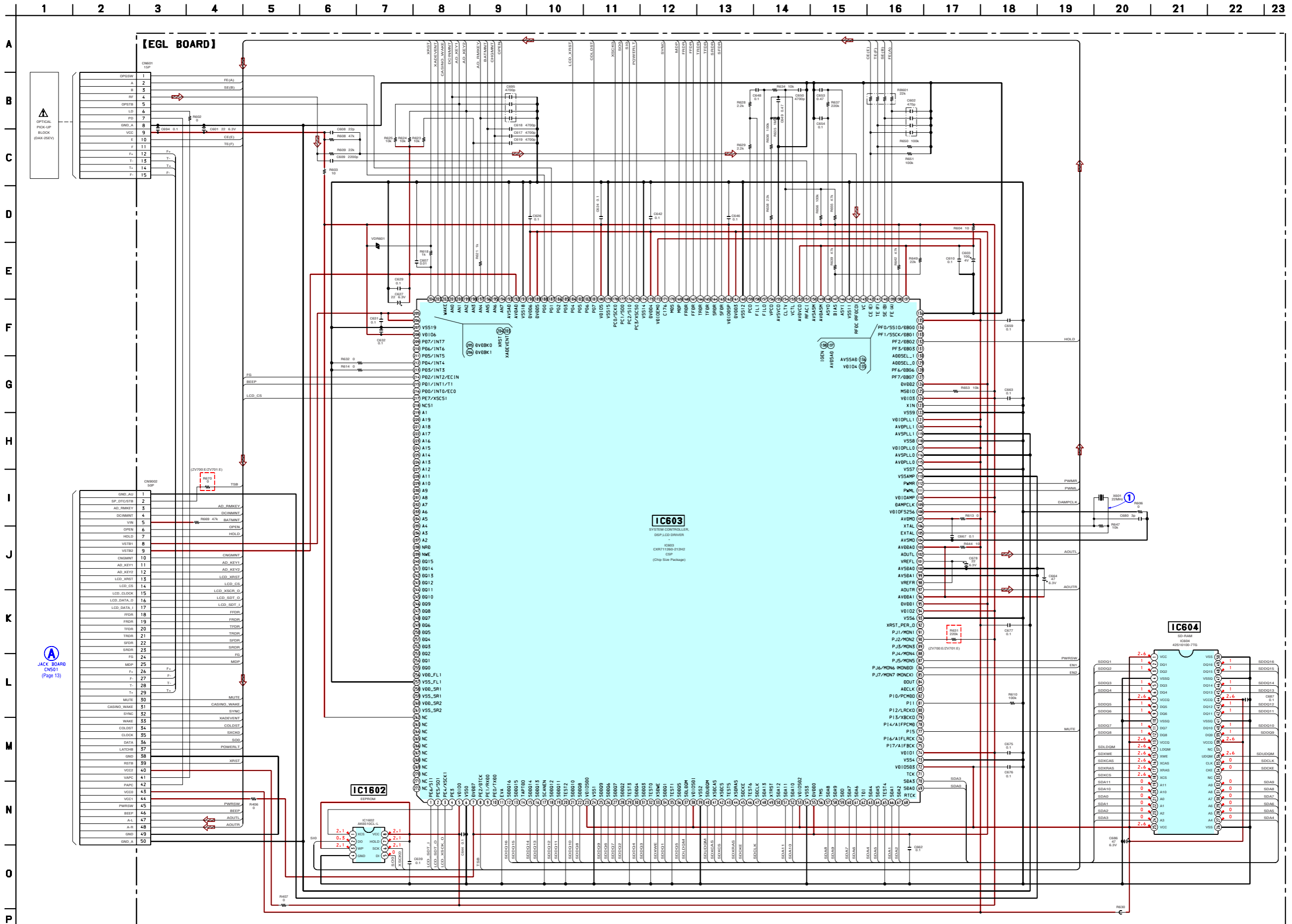

JACK BOARD
CN501
(Page 13)

The components identified by mark Δ or dotted line with mark Δ are critical for safety. Replace only with part number specified.

4-3. PRINTED WIRING BOARD – JACK BOARD (COMPONENT SIDE) –  :Uses unleaded solder.

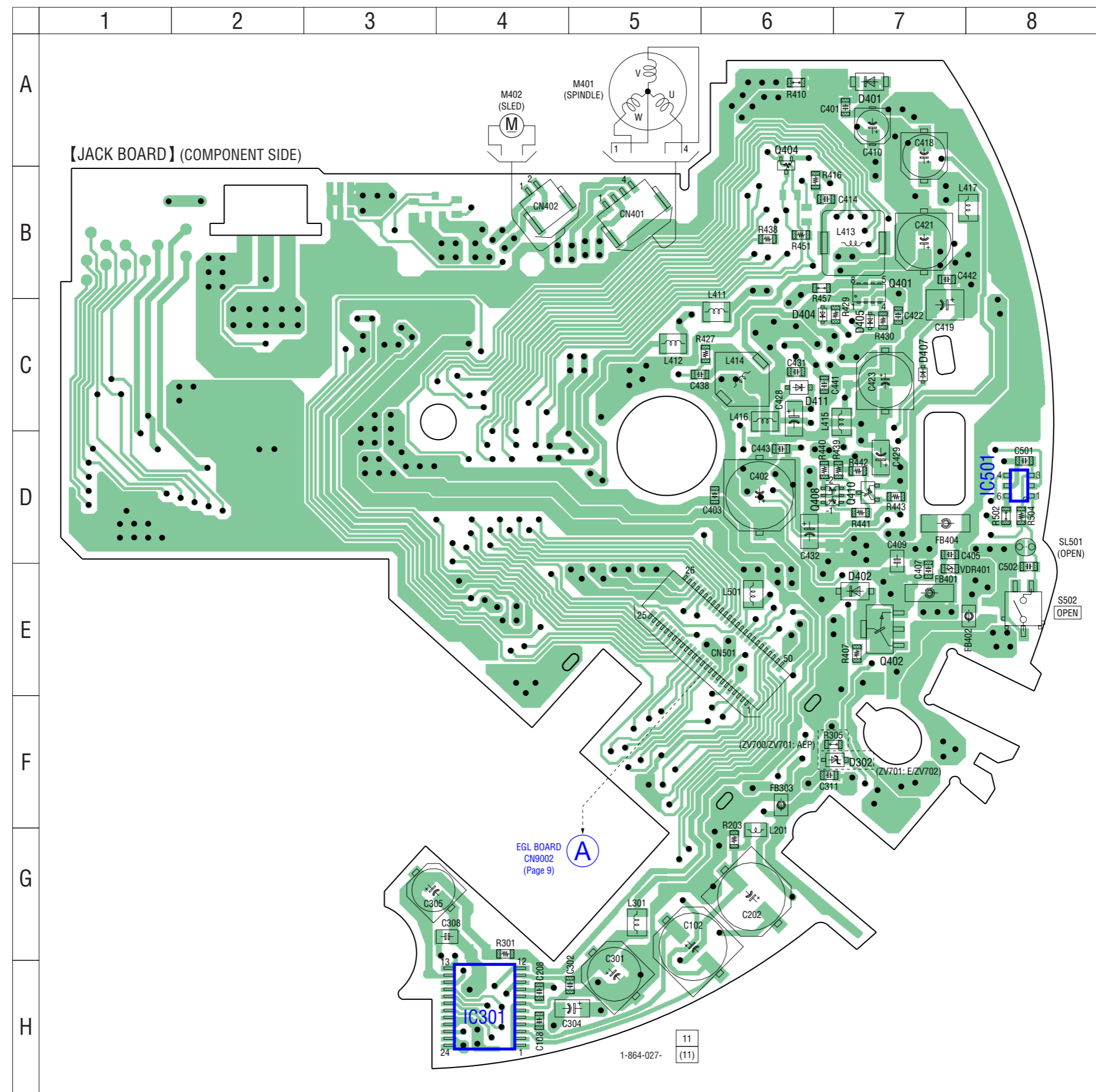

• Semiconductor Location

Ref. No.	Location
D302	F-7
D401	A-7
D402	E-7
D404	C-6
D405	C-7
D407	C-7
D411	C-6
IC301	H-4
IC501	D-8
Q401	B-7
Q402	E-7
Q401	B-7
Q402	E-7
Q404	A-6
Q408	D-6
Q410	D-7

4-4. PRINTED WIRING BOARD – JACK BOARD (CONDUCTOR SIDE) –  :Uses unleaded solder.

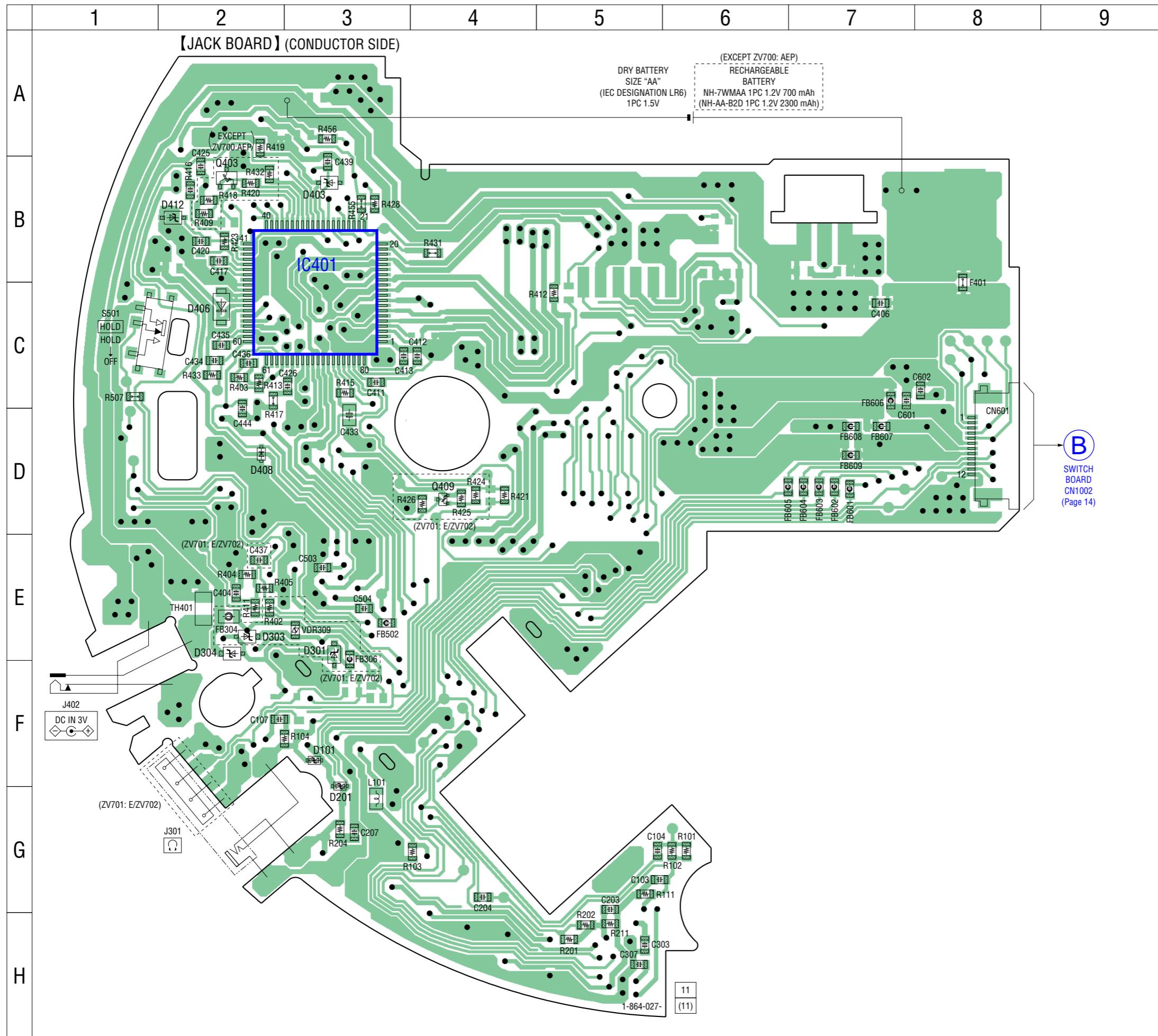

• Semiconductor Location

Ref. No.	Location
D101	F-3
D201	G-3
D301	E-3
D303	E-2
D304	E-2
D403	B-3
D406	C-2
D408	D-2
D412	B-2
IC401	C-3
Q403	B-2
Q409	D-4

B
SWITCH BOARD
CN1002
(Page 14)

4-5. SCHEMATIC DIAGRAM – JACK BOARD – • See page 16 for Waveforms. • See page 16 for IC Block Diagram. • See page 16 for IC Pin Function Description.

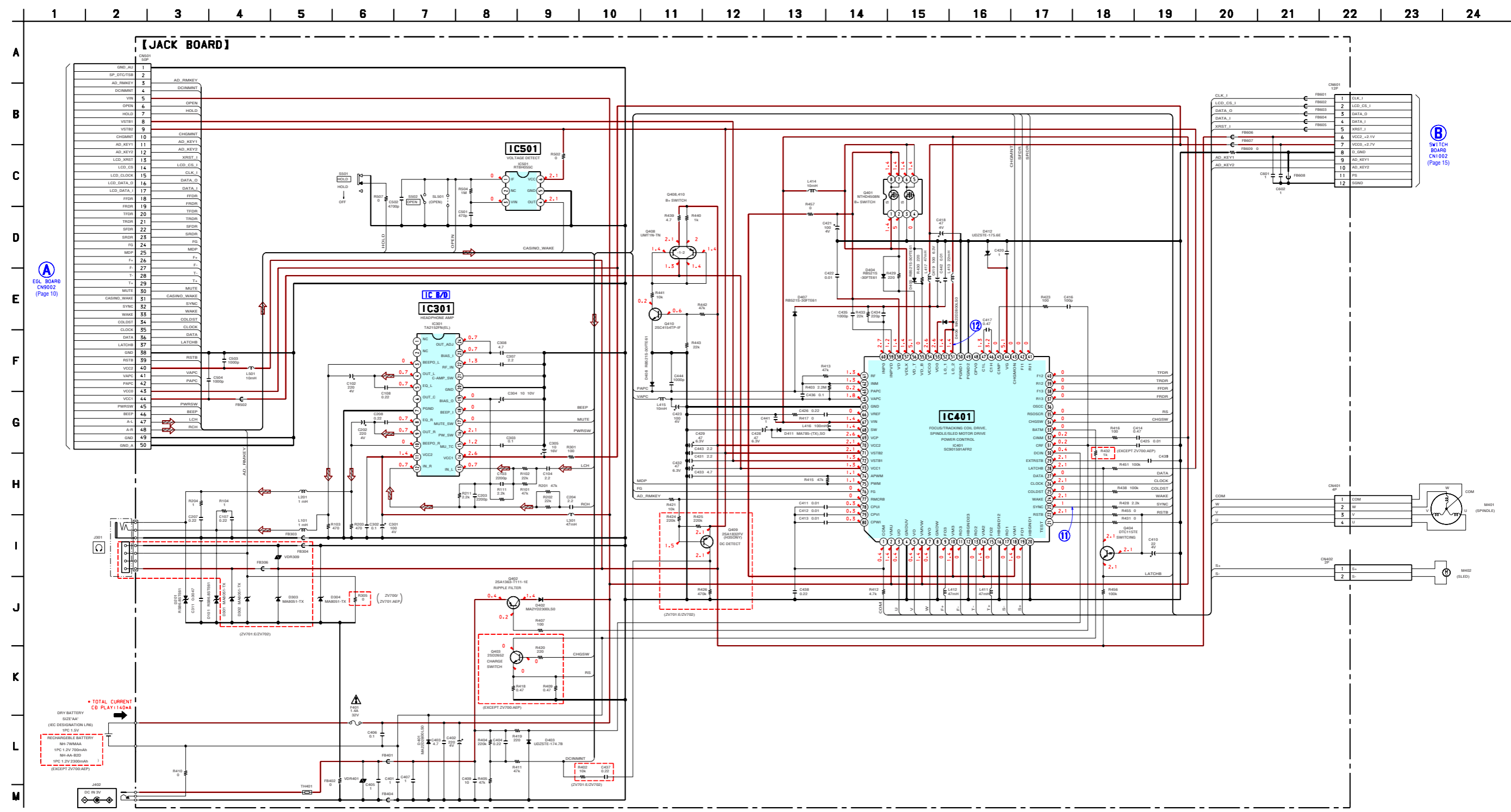

The components identified by mark Δ or dotted line with mark Δ are critical for safety. Replace only with part number specified.

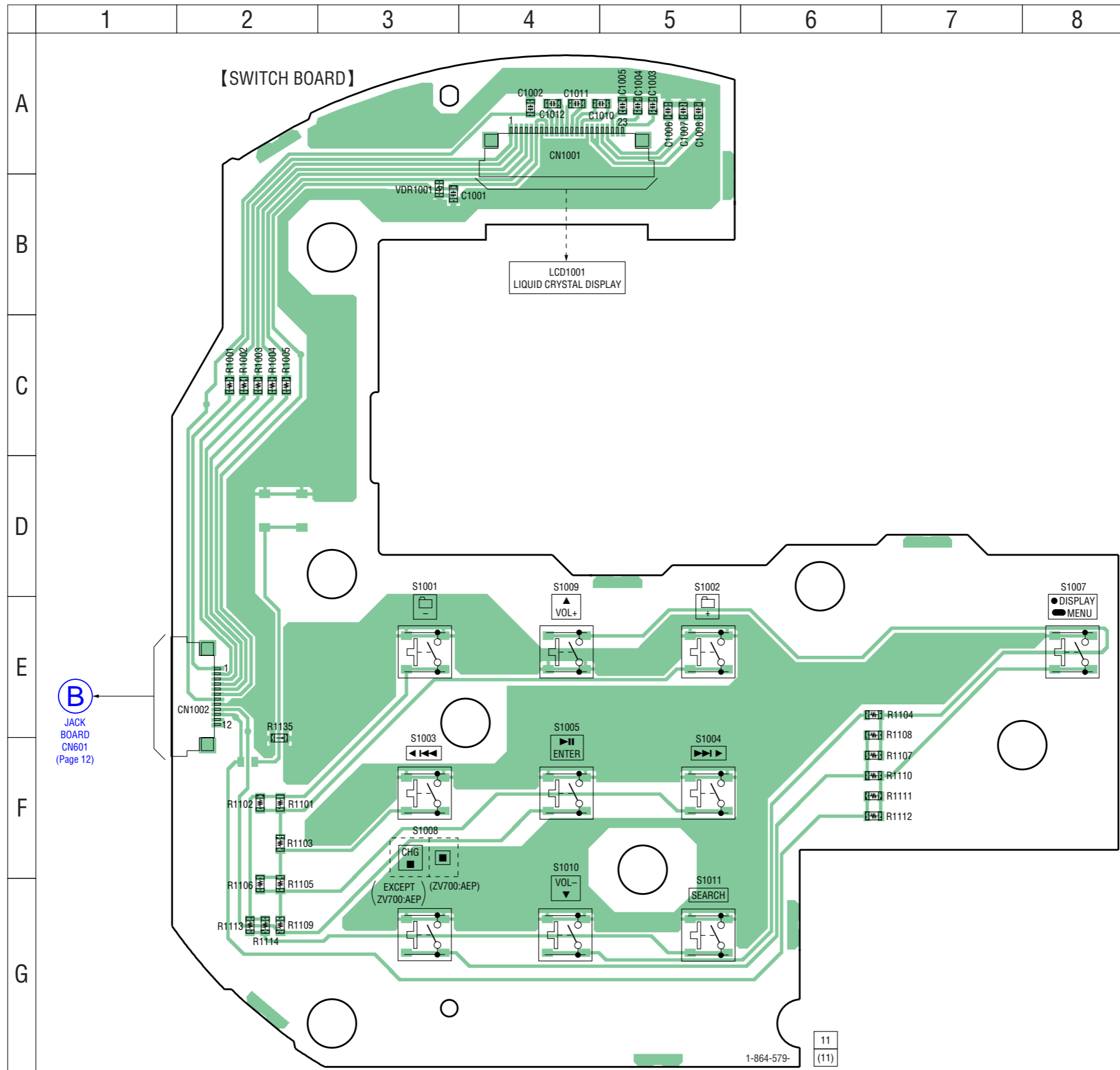

4-7. SCHEMATIC DIAGRAM – SWITCH BOARD –

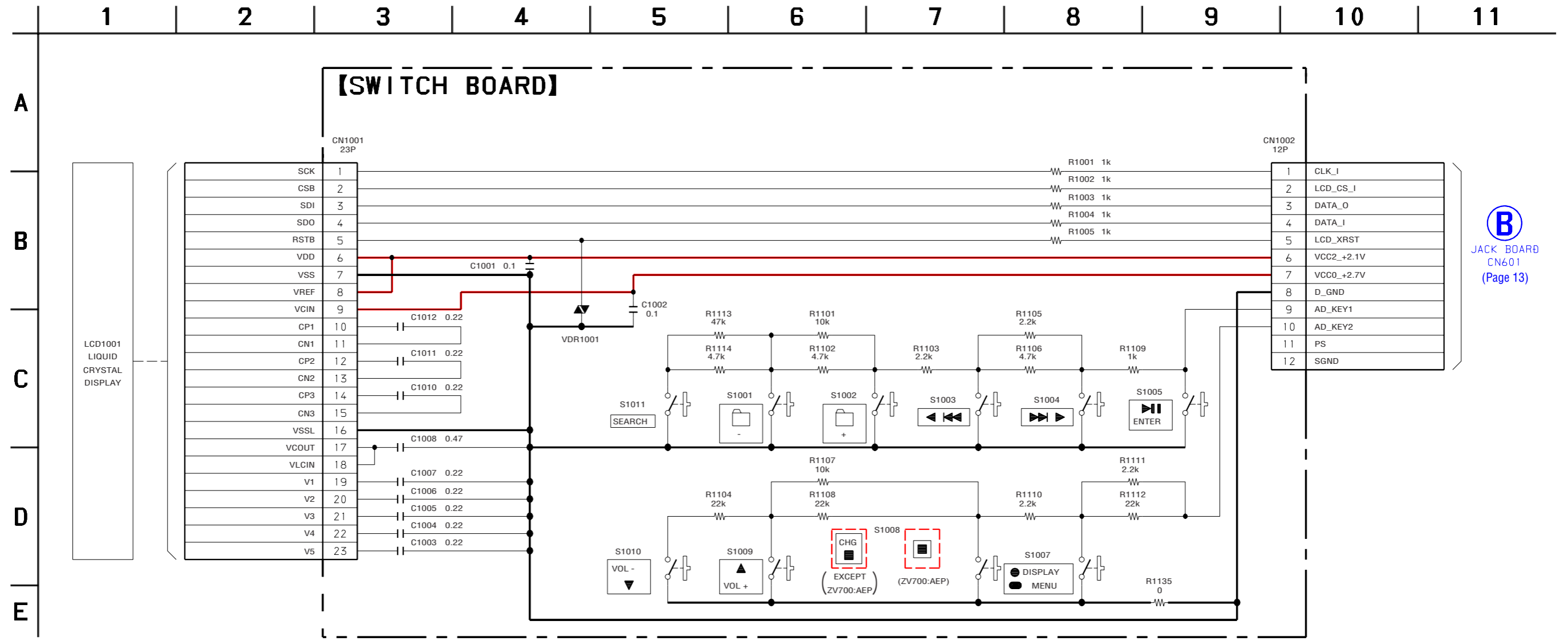

B
JACK BOARD
CN601
(Page 13)

• IC Block Diagram

– JACK Board –

IC301 TA2152FN (EL)

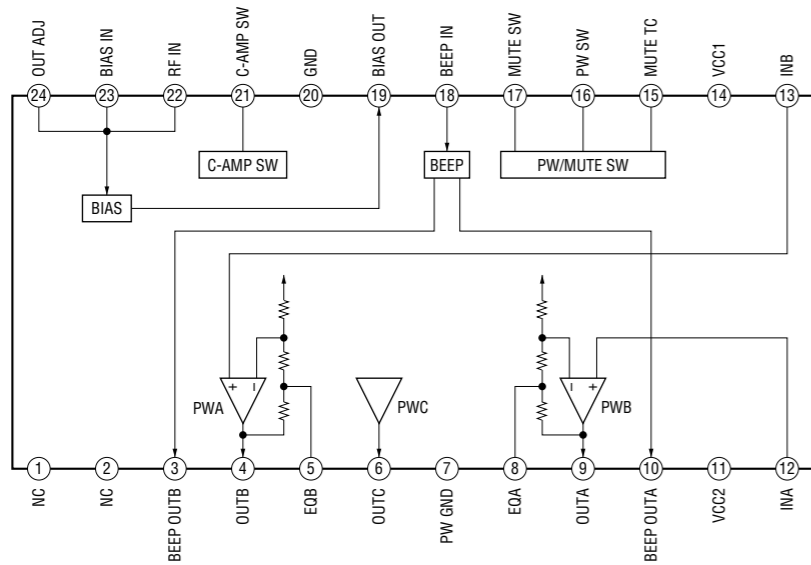

• Waveforms

– EGL Board –

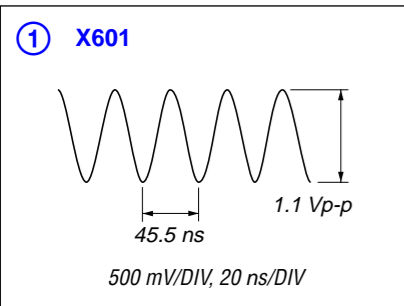

– JACK Board –

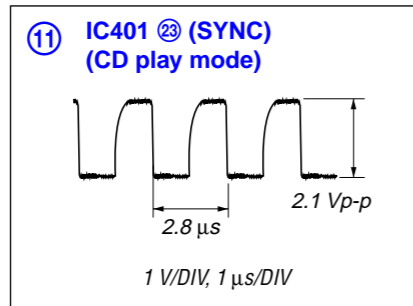

⑫ IC401 ㉑ (LO_2), ㉒ (LO_1)

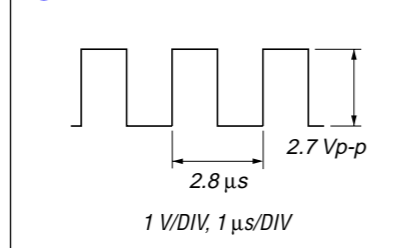

• IC Pin Function Description

EGL BOARD IC603 CXR711260-212H2 (SYSTEM CONTROLLER, DSP, LCD DRIVER)

Pin No.	Pin Name	I/O	Description
1	PE6/SI1	I	Serial data input from the liquid crystal display
2	PE5/SO1	O	Serial data output to the liquid crystal display
3	PE4/XSCK1	O	Serial clock signal output to the liquid crystal display
4	PE3	O	Chip select signal output to the EEPROM
5	VDIO0	—	Power supply terminal (+2.1V)
6	VSS0	—	Ground terminal
7	DVDD7	—	Power supply terminal (+1.3V)
8	PE2/DTCK	I/O	Not used
9	PE1/RXD0	I	Not used
10	PE0/TXD0	O	Not used
11	EVA	—	Not used
12, 13	SDDQ16, SDDQ15	I/O	Two-way data bus with the SD-RAM
14	TAPTDO	—	Not used
15, 16	SDDQ14, SDDQ13	I/O	Two-way data bus with the SD-RAM
17	SCANEN	—	Not used
18, 19	SDDQ12, SDDQ11	I/O	Two-way data bus with the SD-RAM
20	TEST2	—	Not used
21, 22	SDDQ10, SDDQ8	I/O	Two-way data bus with the SD-RAM
23	VDIOSD0	—	Power supply terminal (+2.7V)
24	VSS1	—	Ground terminal
25 to 28	SDDQ9, SDDQ6, SDDQ7, SDDQ2	I/O	Two-way data bus with the SD-RAM
29	TEST3	—	Not used
30, 31	SDDQ4, SDDQ3	I/O	Two-way data bus with the SD-RAM
32	TEST0	—	Not used
33	XSDWE	O	Write enable signal output to the SD-RAM
34	SDDQ1	I/O	Two-way data bus with the SD-RAM
35	TEST1	—	Not used
36	SDDQ5	I/O	Two-way data bus with the SD-RAM
37	SDLDQM	O	Lower byte input/output mask signal to the SD-RAN
38	VDIOSD1	—	Power supply terminal (+2.7V)
39	VSS2	—	Ground terminal
40	SDUDQM	O	Upper byte input/output mask signal to the SD-RAN
41	XSDCAS	O	Column address strobe signal to the SD-RAN
42	XSDCS	O	Chip select signal to the SD-RAN
43	TEST5	—	Not used
44	XSDRAS	O	Row address strobe signal to the SD-RAN
45	SDCKE	O	Clock enable signal to the SD-RAN
46	TEST6	—	Not used
47	SDCLK	O	Clock signal to the SD-RAN
48	SDA13	O	Address signal to the SD-RAN
49	XTRST	—	Not used
50 to 52	SDA12 to SDA10	O	Address signal to the SD-RAN
53	VDIOSD2	—	Power supply terminal (+2.7V)
54	VSS3	—	Ground terminal
55	DVDD0	—	Power supply terminal (+1.3V)
56	TMS	—	Not used

Pin No.	Pin Name	I/O	Description
57, 58	SDA8, SDA9	O	Address signal to the SD-RAN
59	TDO	—	Not used
60, 61	SDA7, SDA6	O	Address signal to the SD-RAN
62	TDI	—	Not used
63, 64	SDA5, SDA4	O	Address signal to the SD-RAN
65	TEST4	—	Not used
66, 67	SDA1, SDA2	O	Address signal to the SD-RAN
68	RTCK	—	Not used
69, 70	SDA0, SDA3	O	Address signal to the SD-RAN
71	TCK	—	Not used
72	VDIOSD3	—	Power supply terminal (+2.7V)
73	VSS4	—	Ground terminal
74	VDIO1	—	Power supply terminal (+2.1V)
75	PI7/AIFBCK	—	Not used
76	PI6/AIFLRCK	—	Not used
77	PI5	O	Muting on/off control signal output to the headphone amplifier “H”: muting on
78	PI4/AIFPCMD	—	Not used
79	PI3/XBCKO	—	Not used
80	PI2/LRCKO	—	Not used
81	PI1	—	Not used
82	PI0/PCMDO	—	Not used
83	ADCLK	—	Not used
84	DOUT	—	Not used
85	PJ7/MON7 (MONCK)	—	Not used
86	PJ6/MON6 (MONDO)	—	Not used
87	PJ5/MON5	O	Amplifier power on/off control signal output to the headphone amplifier “H”: amplifier power on
88 to 91	PJ4/MON4 to PJ1/MON1	—	Not used
92	XRST_PWR_O	—	Not used
93	VSS6	—	Ground terminal
94	VDIO2	—	Power supply terminal (+2.1V)
95	DVDD1	—	Power supply terminal (+1.3V)
96	AVDDA1	—	Power supply terminal (+2.7V)
97	AOUTR	O	Analog audio signal output to the headphone amplifier (R-ch)
98	VREFR	O	Reference voltage output terminal (R-ch)
99, 100	AVSDA1, AVSDA0	—	Ground terminal
101	VREFL	O	Reference voltage output terminal (L-ch)
102	AOUTL	O	Analog audio signal output to the headphone amplifier (L-ch)
103	AVDDA0	—	Power supply terminal (+2.7V)
104	AVSMO	—	Ground terminal
105	EXTAL	O	System clock output terminal (22MHz)
106	XTAL	I	System clock input terminal (22MHz)
107	AVDMO	—	Power supply terminal (+2.7V)
108	VDIOFS256	—	Power supply terminal (+2.1V)
109	DAMPCLK	—	Not used
110	VDIOAMP	—	Power supply terminal (+2.1V)
111	PWML	—	Not used
112	PWMR	—	Not used
113	VSSAMP	—	Ground terminal

Pin No.	Pin Name	I/O	Description
114	VSS7	—	Ground terminal
115	AVDPLL0	—	Power supply terminal (+2.7V)
116	AVSPLL0	—	Ground terminal
117	VDIOPLL0	—	Power supply terminal (+2V)
118	VSS8	—	Ground terminal
119	AVSPLL1	—	Ground terminal
120	AVDPLL1	—	Power supply terminal (+2.7V)
121	VDIOPLL1	—	Power supply terminal (+2V)
122	VSS9	—	Ground terminal
123	XIN	—	Not used
124	VDIO3	—	Power supply terminal (+2.1V)
125	MSDIO	—	Not used
126	DVDD2	—	Power supply terminal (+1.3V)
127, 128	PF7/DBG7, PF6/DBG6	—	Not used
129, 130	ADDSEL_0, ADDSEL_1	—	Not used
131	PF3/DBG3	—	Not used
132	PF2/DBG2	I	HOLD switch input terminal “L”: hold on
133	PF1/SSCK/DBG1	—	Not used
134	PF0/SSIO/DBG0	—	Not used
135	VDIO4	—	Power supply terminal (+2V)
136	AVSSAD	—	Ground terminal
137	AVDSAD	—	Power supply terminal (+2.1V)
138	IGEN	I	Stabilized current input for operational amplifiers
139	FE (A)	I	A signal input from the optical pick-up block
140	SE (B)	I	B signal input from the optical pick-up block
141	TE (F)	I	F signal input from the optical pick-up block
142	CE (E)	I	E signal input from the optical pick-up block
143	VC	I	Middle point voltage input terminal Not used
144	RFDC (RFDCO)	I	RF signal input from the optical pick-up block
145	VSS11	—	Ground terminal
146	ASYI	I	Asymmetry comparator voltage input terminal
147	BIAS	I	Asymmetry circuit constant current input terminal
148	ASYO	O	EFM full-swing output terminal
149	AVDASM	—	Power supply terminal (+2.1V)
150	AVSASM	—	Ground terminal
151	RFACI	I	EFM signal input from the optical pick-up
152	AVDVCO	—	Power supply terminal (+2.1V)
153	VCTL	I	VCO control voltage input terminal for the wideband EFM PLL
154	CLTV	I	Internal VCO control voltage input terminal
155	AVSVCO	—	Ground terminal
156	VPCO	O	Charge pump output terminal for the wideband EFM PLL
157	FILO	O	Filter output for master PLL
158	FILI	I	Filter input for master PLL
159	PCO	O	Charge pump output for master PLL
160	VSS12	—	Ground terminal
161	DVDD3	—	Power supply terminal (+1.3V)
162	VDIODSP	—	Power supply terminal (+2V)
163	SFDR	O	Sled servo drive signal (+) output to the motor/coil drive
164	SRDR	O	Sled servo drive signal (-) output to the motor/coil drive

Pin No.	Pin Name	I/O	Description
165	TFDR	O	Tracking servo drive signal (+) output to the motor/coil drive
166	TRDR	O	Tracking servo drive signal (-) output to the motor/coil drive
167	FFDR	O	Focus servo drive signal (+) output to the motor/coil drive
168	FRDR	O	Focus servo drive signal (-) output to the motor/coil drive
169	MDP	O	Spindle motor servo drive signal output to the motor/coil drive
170	MDS	—	Not used
171	C176	O	176.4 kHz clock signal output to the motor/coil drive
172	VDIOEM0	—	Power supply terminal (+2V)
173	DVDD4	—	Power supply terminal (+1.3V)
174	VSS14	—	Ground terminal
175	PC3/XSCS0	O	Command latch signal output to the power control
176	PC2/SI0	I	Serial data input from the EEPROM
177	PC1/SO0	O	Serial data output to the power control and EEPROM
178	PC0/SCK0	O	Serial clock signal output to the power control and EEPROM
179	VSS15	—	Ground terminal
180	VDIO5	—	Power supply terminal (+2V)
181	PG7	O	Cold start flag input from the power control
182, 183	PG6, PG5	—	Not used
184	PG4	O	Reset signal output to the liquid crystal display
185, 186	PG3, PG2	—	Not used
187	PG1	O	Standby signal output to the optical pick-up block
188	PG0	O	RF gain-up signal output for CD-RW to the optical pick-up block
189, 190	DVDD5, DVDD6	—	Power supply terminal (+1.3V)
191	VSS18	—	Ground terminal
192	AVDAD	—	Power supply terminal (+2V)
193	AVSAD	—	Ground terminal
194	AN7	I	CD lid open/close switch input terminal “L”: close, “H”: open
195	AN6	I	Charge voltage monitor input from the power control
196	AN5	I	Battery voltage monitor input terminal
197	AN4	I	Wake up signal input from the power control Remote commander key input terminal (ZV701: E/ZV702 models only)
198	AN3	—	Not used
199, 200	AN2, AN1	I	Top panel key input terminal (A/D input)
201	AN0	I	DCIN voltage monitor input terminal
202	WAKE	I	Wake up signal input terminal
203	XADEVENT	O	Wake up signal output to the power control
204	XRST	I	System reset signal input from the power control
205, 206	DVDBK0, DVDBK1	—	Power supply terminal (+1.2V)
207	VSS19	—	Ground terminal
208	VDIO6	—	Power supply terminal (+2V)
209 to 213	PD7/INT7 to PD3/INT3	—	Not used
214	PD2/INT2/ECIN	I	FG signal input from the motor/coil drive
215	PD1/INT1/T1	O	Beep signal output to the headphone amplifier
216	PD0/INT0/EC0	—	Not used
217	PE7/XSCS1	O	Command latch signal output to the liquid crystal display
218	NCS1	—	Not used
219 to 237	A0, A19 to A1	—	Not used
238	NRD	—	Not used
239	NWE	—	Not used

XP-ZV700/ZV701/ZV702

Pin No.	Pin Name	I/O	Description
240 to 255	DQ15 to DQ0	—	Not used
256	VDD_FL1	—	Power supply terminal Not used
257	VSS_FL1	—	Ground terminal
258	VDD_SR1	—	Power supply terminal Not used
259	VSS_SR1	—	Ground terminal
260	VDD_SR2	—	Power supply terminal Not used
261	VSS_SR2	—	Ground terminal
262 to 272	NC	—	Not used

**JACK BOARD IC401 SC901591AFR2
(FOCUS/TRACKING COIL DRIVE, SPINDLE/SLED MOTOR DRIVE, POWER CONTROL)**

Pin No.	Pin Name	I/O	Description
1	COM	I	Comparator (U/V/W) negative pole input terminal
2	VMU	—	Power supply terminal (for spindle motor drive U phase)
3	UO	O	Spindle motor drive U phase output terminal
4	GNDUV	—	Ground terminal (for spindle motor drive U/V phase)
5	VO	O	Spindle motor drive V phase output terminal
6	VMVW	—	Power supply terminal (for spindle motor drive V/W phase)
7	WO	O	Spindle motor drive V phase output terminal
8	GNDW	—	Ground terminal (for spindle motor drive W phase)
9	FO3	O	Focus coil drive signal (+) output terminal
10	VM3	—	Power supply terminal (for focus coil drive)
11	RO3	O	Focus coil drive signal (-) output terminal
12	HBGND23	—	Ground terminal (for focus/tracking coil drive)
13	RO2	O	Tracking coil drive signal (-) output terminal
14	VM2	—	Power supply terminal (for tracking coil drive)
15	FO2	O	Tracking coil drive signal (+) output terminal
16	HBGND12	—	Ground terminal (for tracking coil drive and sled motor drive)
17	RO1	O	Sled motor drive signal (-) output terminal
18	VM1	—	Power supply terminal (for sled motor drive)
19	FO1	O	Sled motor drive signal (+) output terminal
20	HBGND1	—	Ground terminal (for sled motor drive)
21	TEST	—	Test mode terminal
22	RSTB	O	System reset signal output to the system controller
23	SYNC	I	176.4 kHz clock signal input from the system controller
24	WAKE	I	Wake up signal input from the system controller
25	COLDST	O	Cold start flag output to the system controller
26	CLOCK	I	Serial clock signal input from the system controller
27	DATA	I	Serial data input from the system controller
28	LATCHB	I	Command latch signal input from the system controller
29	EXTRSTB	I	External reset signal input terminal Not used
30	DCIN	—	AC adapter power supply connection terminal
31	CRF	O	Battery charge circuit error amplifier output for rechargeable battery
32	CINM	I	Battery charge circuit error amplifier invert input for rechargeable battery
33	BATM	—	Rechargeable battery minus terminal (Except ZV700: AEP models only)
34	CHGSW	O	Battery charge control transistor drive signal output for rechargeable battery (Except ZV700: AEP models only)
35	RSOSCR	—	Connection terminal of sense resistor and external resistor for internal oscillation circuit (Except ZV700: AEP models only)
36	OSCC	—	External capacitor connection terminal for internal oscillation circuit
37	RI3	I	Focus servo drive signal (-) input from the system controller
38	FI3	I	Focus servo drive signal (+) input from the system controller
39	RI2	I	Tracking servo drive signal (-) input from the system controller
40	FI2	I	Tracking servo drive signal (+) input from the system controller
41	RI1	I	Sled servo drive signal (-) input from the system controller
42	FI1	I	Sled servo drive signal (+) input from the system controller
43	CHGMON	O	Charge voltage monitor output to the system controller
44	VG	O	VG power supply output terminal (+5V) Not used
45	CINP	I	Battery charge circuit error amplifier non-invert input for rechargeable battery

Pin No.	Pin Name	I/O	Description
46	C1H	—	Capacitor connection terminal for charge pump (high side) of VG power supply circuit
47	C1L	—	Capacitor connection terminal for charge pump (low side) of VG power supply circuit
48	CPVO	I	Check terminal for phase compensation VCC0 power supply phase
49, 50	PGND2, PGND1	—	Ground terminal (for VCC0 switching power supply circuit)
51, 52	LO_2, LO_1	—	Coil connection terminal for VCC0 switching power supply circuit
53	VO0	O	VO0 voltage output terminal of switching power supply circuit Not used
54	VCC0	O	VCC0 power supply voltage output terminal (+2.7V)
55	VD_B	O	FET (bottom side) drive signal output for VD switching power supply circuit
56	VD_T	O	FET (top side) drive signal output for VD switching power supply circuit
57	VDLX	—	Coil connection terminal for VD switching power supply circuit
58	VD	I	Feed back voltage input terminal of VD switching power supply circuit
59	INPVD	I	Error amplifier non-invert input of VD switching power supply circuit
60	INP0	I	Error amplifier non-invert input of VCC0 switching power supply circuit
61	RF	—	Error amplifier connection terminal of APC circuit
62	INM	O	Error amplifier output terminal of APC circuit
63	PAPC	I	Feed back voltage input terminal of APC circuit
64	VAPC	O	Voltage output terminal of APC circuit
65	GND	—	Ground terminal
66	VREF	O	Reference voltage output terminal
67	VIN	—	Dry battery connection terminal
68	SW	—	Coil connection terminal for VCP power supply circuit
69	VCP	O	Voltage output terminal of VCP power supply circuit
70	VCC2	O	VCC2 power supply voltage output terminal (+2.1V)
71	VSTB2	O	Standby power supply (2) output terminal (+2V)
72	VSTB1	O	Standby power supply (1) output terminal (+1.2V)
73	VCC1	O	VCC1 power supply voltage output terminal (+1.3V)
74, 75	APWM, PWM	I	Spindle motor servo drive signal input from the system controller
76	FG	O	FG signal output to the system controller
77	RMCRB	O	Wake up signal output to the system controller
78	CPUI	I	Comparator (U) positive pole input terminal
79	CPVI	I	Comparator (V) positive pole input terminal
80	CPWI	I	Comparator (W) positive pole input terminal

SECTION 5 EXPLODED VIEWS

NOTE:

- -XX and -X mean standardized parts, so they may have some difference from the original one.
- Items marked “*” are not stocked since they are seldom required for routine service. Some delay should be anticipated when ordering these items.
- The mechanical parts with no reference number in the exploded views are not supplied.

- Color Indication of Appearance Parts
Example:
KNOB, BALANCE (WHITE) . . . (RED)
↑ ↑
Parts of Color Cabinet's Color
- Accessories are given in the last of the electrical parts list.
- Refer to “COLOR VARIATION” in the “SERVICING NOTES” (page 4) about color variation of model and destination.

The components identified by mark Δ or dotted line with mark Δ are critical for safety. Replace only with part number specified.

5-1. CABINET (UPPER) SECTION

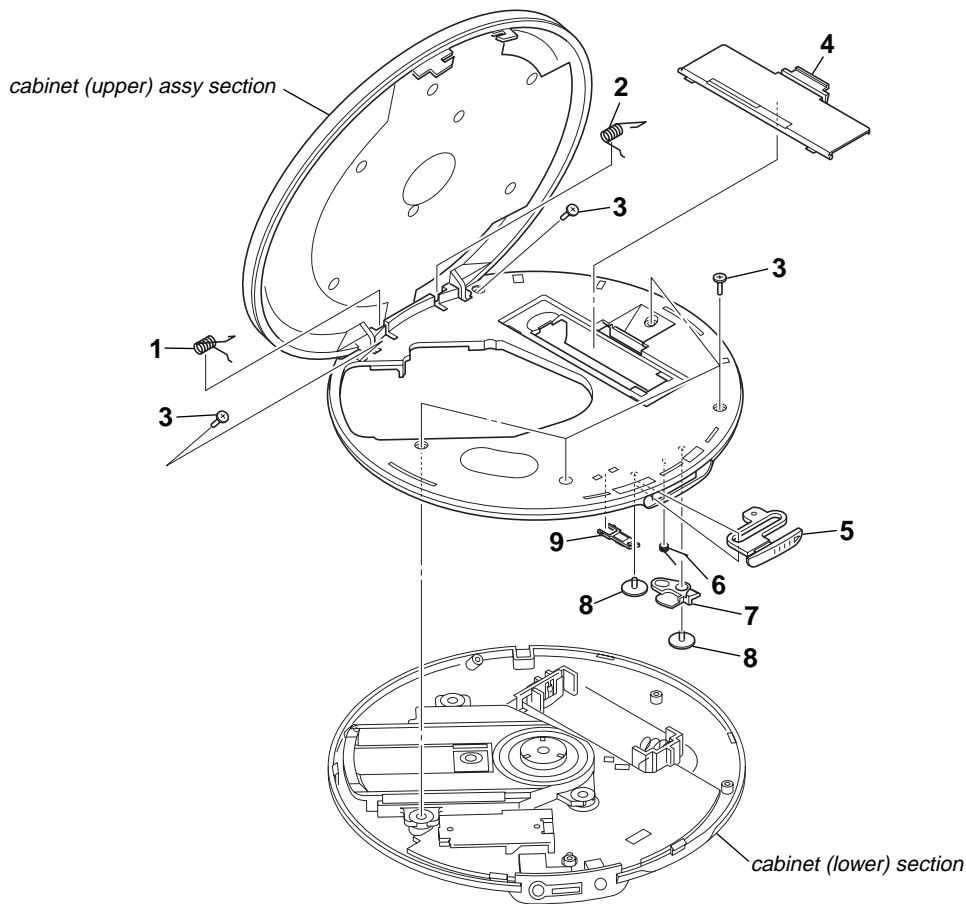

<u>Ref. No.</u>	<u>Part No.</u>	<u>Description</u>	<u>Remark</u>	<u>Ref. No.</u>	<u>Part No.</u>	<u>Description</u>	<u>Remark</u>
1	2-342-680-01	SPRING (FULL OPEN L)		5	2-187-912-31	KNOB (OPEN) (BLACK)	
2	2-342-679-01	SPRING (FULL OPEN R)		6	2-187-914-01	SPRING (OPEN)	
3	3-254-058-11	SCREW		7	2-187-913-01	LEVER (OPEN)	
4	2-188-316-21	LID, BATTERY CASE (WHITE)		8	3-034-792-11	SCREW, TAPPING (B2.0)	
4	2-188-316-31	LID, BATTERY CASE (BLACK)		9	3-261-240-02	LEVER (DETECTION)	
5	2-187-912-21	KNOB (OPEN) (WHITE)					

5-2. CABINET (UPPER) ASSY SECTION

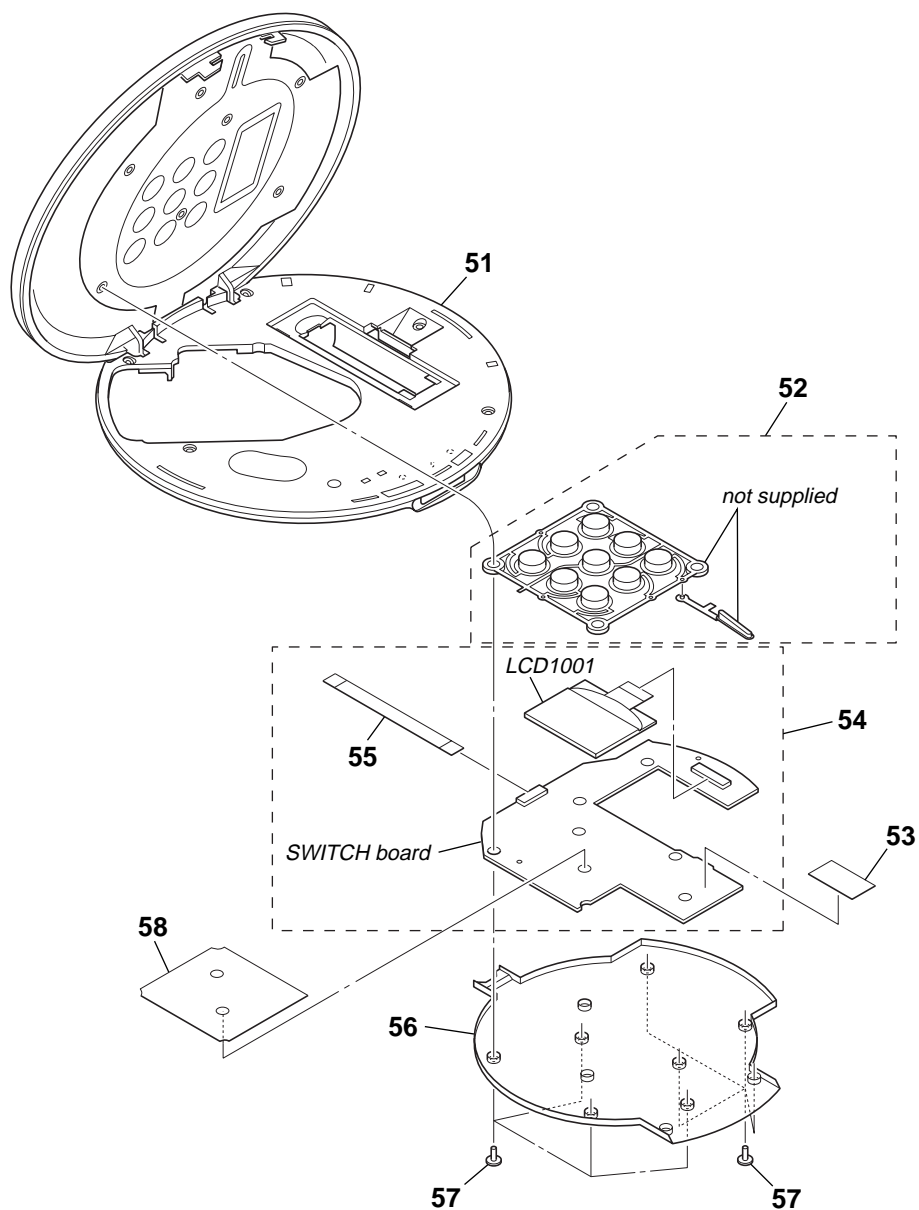

Ref. No.	Part No.	Description	Remark	Ref. No.	Part No.	Description	Remark
51	X-2050-970-1	CABINET (UPPER) SUB ASSY (W) (WHITE)	(ZV700: E)	51	X-2050-978-1	CABINET (UPPER) SUB ASSY (B) (BLACK)	(ZV700: AEP)
51	X-2050-971-1	CABINET (UPPER) SUB ASSY (B) (BLACK)	(ZV700: E)	52	2-189-517-01	BUTTON (OPERATION) (GROUP -, VOL +, GROUP +, ◀▶, ▶▶ ENTER, ▶▶▶, ■, VOL -, SEARCH)	
51	X-2050-973-1	CABINET (UPPER) SUB ASSY (W) (WHITE)	(ZV701)	53	2-342-711-01	SHEET (MENU), INSULATING	
51	X-2050-974-1	CABINET (UPPER) SUB ASSY (B) (BLACK)	(ZV701: AEP)	54	A-1083-828-A	SWITCH BOARD, COMPLETE	
51	X-2050-975-1	CABINET (UPPER) SUB ASSY (W) (WHITE)	(ZV702)	55	1-829-981-11	CABLE, FLEXIBLE FLAT (12 CORE)	
51	X-2050-976-1	CABINET (UPPER) SUB ASSY (B) (BLACK)	(ZV702)	56	2-189-518-01	COVER (SW PWB) (WHITE)	
51	X-2050-977-1	CABINET (UPPER) SUB ASSY (W) (WHITE)	(ZV700: AEP)	56	2-189-518-11	COVER (SW PWB) (BLACK)	
				57	3-254-082-01	SCREW	
				58	2-342-710-01	SHEET (OPERATION), INSULATING	
				LCD1001	1-805-689-11	DISPLAY PANEL, LIQUID CRYSTAL	

5-3. CABINET (LOWER) SECTION

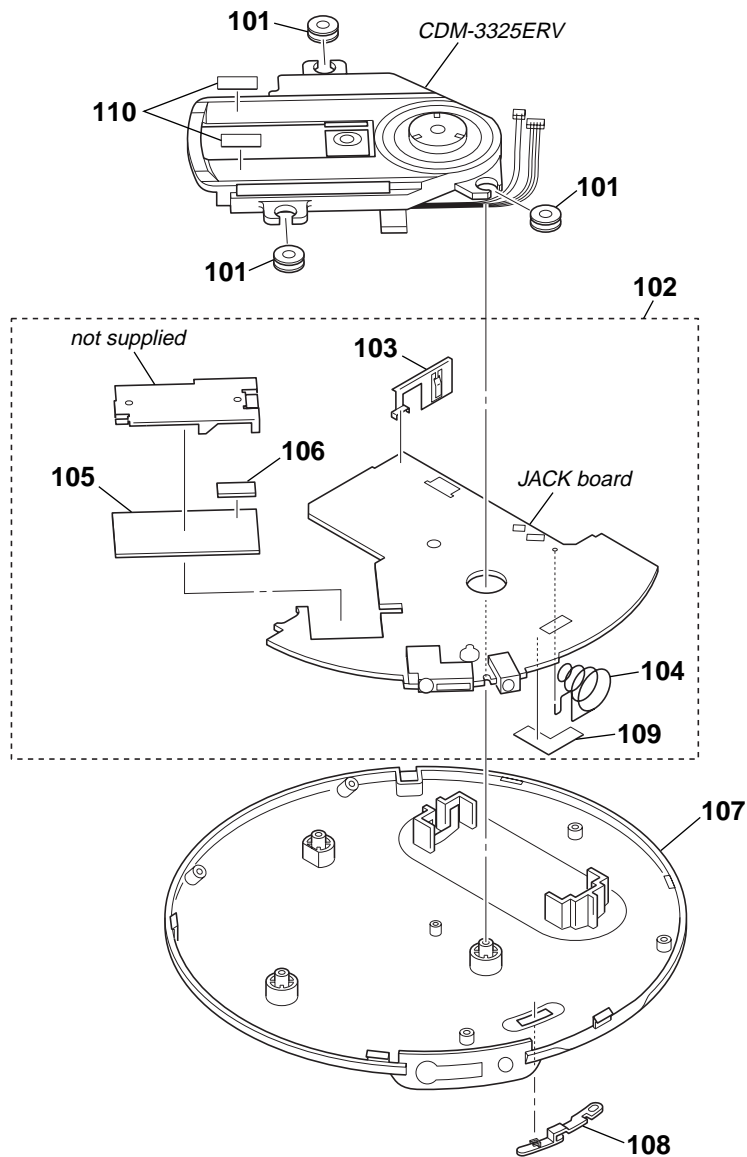

Ref. No.	Part No.	Description	Remark	Ref. No.	Part No.	Description	Remark
101	3-245-331-02	INSULATOR		104	2-187-917-11	SPRING (-), COIL (ZV700: AEP)	
102	A-1083-829-A	JACK BOARD, COMPLETE (Including EGL BOARD, COMPLETE) (ZV702)		105	A-1083-904-A	EGL BOARD, COMPLETE (Included in JACK BOARD, COMPLETE) (ZV700: AEP/ZV701: AEP/ZV702)	
102	A-1083-831-A	JACK BOARD, COMPLETE (Including EGL BOARD, COMPLETE) (ZV700: E)		105	A-1083-905-A	EGL BOARD, COMPLETE (Included in JACK BOARD, COMPLETE) (ZV700: E/ZV701: E)	
102	A-1083-832-A	JACK BOARD, COMPLETE (Including EGL BOARD, COMPLETE) (ZV701: AEP)		106	2-589-207-01	SHIELD, CUSHION	
102	A-1083-833-A	JACK BOARD, COMPLETE (Including EGL BOARD, COMPLETE) (ZV700: AEP)		107	2-187-915-51	CABINET (LOWER) (WHITE)	
102	A-1083-835-A	JACK BOARD, COMPLETE (Including EGL BOARD, COMPLETE) (ZV701: E)		107	2-187-915-61	CABINET (LOWER) (BLACK)	
103	2-187-916-01	TERMINAL BOARD (+) (EXCEPT ZV700: AEP)		108	2-188-315-21	KNOB (HOLD) (WHITE)	
103	2-187-916-11	TERMINAL BOARD (+) (ZV700: AEP)		108	2-188-315-31	KNOB (HOLD) (BLACK)	
104	2-187-917-01	SPRING (-), COIL (EXCEPT ZV700: AEP)		109	2-590-110-01	INSULATING SHEET (HOLD)	
				110	3-266-622-01	SHEET (CDM)	

5-4. OPTICAL PICK-UP SECTION (CDM-3325ERV)

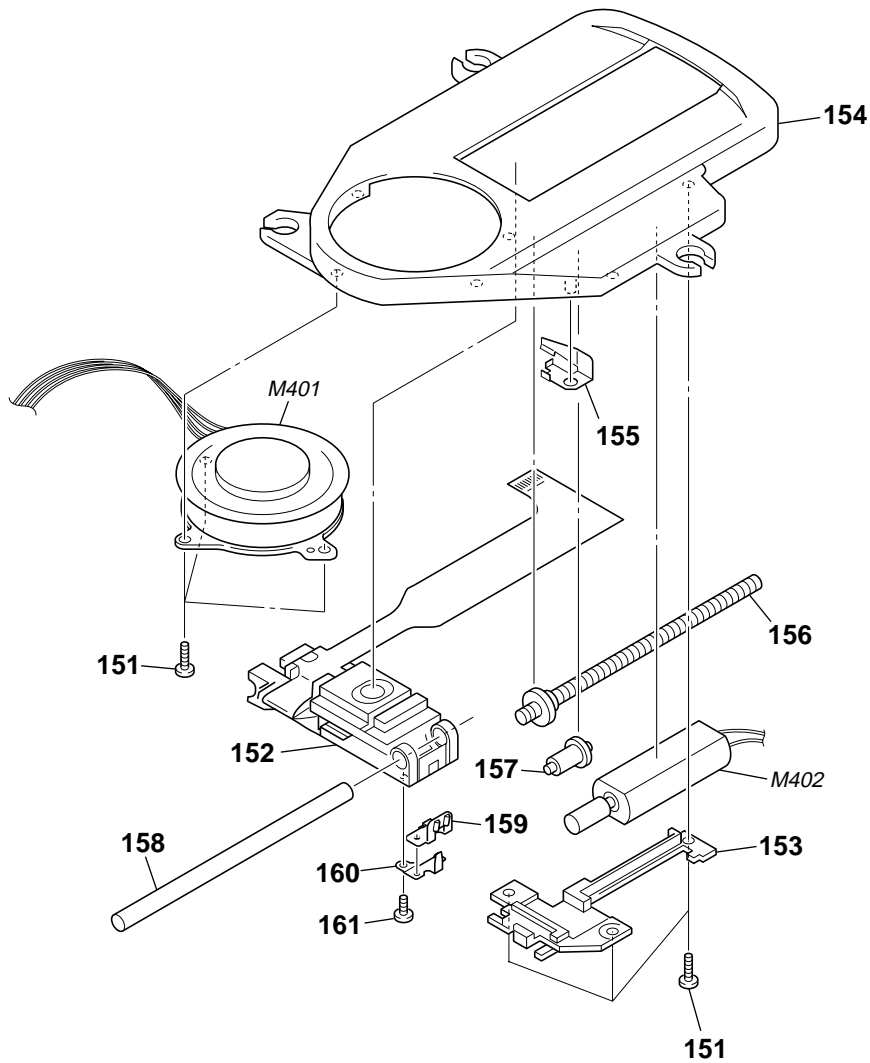

Ref. No.	Part No.	Description	Remark	Ref. No.	Part No.	Description	Remark
151	3-318-203-61	SCREW (B1.7X4), TAPPING		158	3-221-475-01	SHAFT, STANDARD	
△ 152	X-3383-995-1	OPTICAL PICK-UP (DAX-25EV)		159	3-222-298-01	RACK	
153	3-221-473-01	COVER, GEAR		160	3-222-299-01	SPRING, RACK RETAINER	
154	3-221-472-02	CHASSIS		161	3-348-998-31	SCREW (M1.4X2.5), TAPPING, PAN	
155	3-221-474-01	SPRING, SLED		M401	A-1061-632-A	TABLE ASSY, TURN (SPINDLE)	
156	A-1061-631-A	SCREW (FEED) ASSY		M402	A-1061-630-A	MOTOR ASSY, SLED	
157	3-221-268-01	GEAR (B)					

The components identified by mark △ or dotted line with mark △ are critical for safety. Replace only with part number specified.

SECTION 6 ELECTRICAL PARTS LIST

EGL

NOTE:

- Due to standardization, replacements in the parts list may be different from the parts specified in the diagrams or the components used on the set.
- -XX and -X mean standardized parts, so they may have some difference from the original one.
- RESISTORS
All resistors are in ohms.
METAL: Metal-film resistor.
METAL OXIDE: Metal oxide-film resistor.
F: nonflammable

- Items marked “*” are not stocked since they are seldom required for routine service. Some delay should be anticipated when ordering these items.
- SEMICONDUCTORS
In each case, u: μ , for example:
uA. . : μ A. . . uPA. . : μ PA. .
uPB. . : μ PB. . . uPC. . : μ PC. .
uPD. . : μ PD. . .
- CAPACITORS
uF: μ F
- COILS
uH: μ H

When indicating parts by reference number, please include the board name.

The components identified by mark \triangle or dotted line with mark \triangle are critical for safety. Replace only with part number specified.

- Abbreviation
E18 : Singapore model
E33 : Chilean and Peruvian model
- Refer to “COLOR VARIATION” in the “SERVICING NOTES” (page 4) about color variation of model and destination.

Ref. No.	Part No.	Description	Remark
	A-1083-904-A	EGL BOARD, COMPLETE (ZV700: AEP/ZV701: AEP/ZV702: AEP)	
	A-1083-905-A	EGL BOARD, COMPLETE (ZV700: E/ZV701: E) ***** (Included in JACK BOARD, COMPLETE)	
< CAPACITOR >			
C601	1-119-750-11	TANTALUM CHIP 22uF	20% 6.3V
C602	1-112-063-11	CERAMIC CHIP 470PF	10% 50V
C603	1-100-661-11	TANTALUM CHIP 100uF	20% 4V
C607	1-164-943-11	CERAMIC CHIP 0.01uF	10% 16V
C608	1-164-858-11	CERAMIC CHIP 22PF	5% 50V
C609	1-164-939-11	CERAMIC CHIP 0.0022uF	10% 50V
C610	1-107-820-11	CERAMIC CHIP 0.1uF	16V
C617	1-164-941-11	CERAMIC CHIP 0.0047uF	10% 16V
C618	1-164-941-11	CERAMIC CHIP 0.0047uF	10% 16V
C619	1-164-941-11	CERAMIC CHIP 0.0047uF	10% 16V
C624	1-107-820-11	CERAMIC CHIP 0.1uF	16V
C626	1-107-820-11	CERAMIC CHIP 0.1uF	16V
C627	1-119-750-11	TANTALUM CHIP 22uF	20% 6.3V
C629	1-107-820-11	CERAMIC CHIP 0.1uF	16V
C631	1-107-820-11	CERAMIC CHIP 0.1uF	16V
C632	1-107-820-11	CERAMIC CHIP 0.1uF	16V
C639	1-107-820-11	CERAMIC CHIP 0.1uF	16V
C642	1-107-820-11	CERAMIC CHIP 0.1uF	16V
C644	1-107-820-11	CERAMIC CHIP 0.1uF	16V
C646	1-107-820-11	CERAMIC CHIP 0.1uF	16V
C648	1-125-777-11	CERAMIC CHIP 0.1uF	10% 10V
C649	1-100-415-11	CERAMIC CHIP 0.47uF	10% 6.3V
C650	1-164-941-11	CERAMIC CHIP 0.0047uF	10% 16V
C653	1-100-415-11	CERAMIC CHIP 0.47uF	10% 6.3V
C654	1-125-777-11	CERAMIC CHIP 0.1uF	10% 10V
C659	1-107-820-11	CERAMIC CHIP 0.1uF	16V
C662	1-107-820-11	CERAMIC CHIP 0.1uF	16V
C663	1-107-820-11	CERAMIC CHIP 0.1uF	16V
C664	1-100-539-11	TANTALUM CHIP 47uF	20% 6.3V
C667	1-107-820-11	CERAMIC CHIP 0.1uF	16V
C675	1-107-820-11	CERAMIC CHIP 0.1uF	16V
C676	1-107-820-11	CERAMIC CHIP 0.1uF	16V
C677	1-107-820-11	CERAMIC CHIP 0.1uF	16V
C678	1-119-750-11	TANTALUM CHIP 22uF	20% 6.3V
C680	1-164-843-11	CERAMIC CHIP 3PF	0.25PF 50V
C686	1-100-539-11	TANTALUM CHIP 47uF	20% 6.3V
C687	1-107-820-11	CERAMIC CHIP 0.1uF	16V
C694	1-125-777-11	CERAMIC CHIP 0.1uF	10% 10V
C695	1-100-945-11	CERAMIC CHIP 4700PF	10% 25V

Ref. No.	Part No.	Description	Remark
< CONNECTOR >			
CN601	1-818-130-11	CONNECTOR, FFC/FPC (ZIF) 15P	
CN9002	1-818-892-11	CONNECTOR, BOARD TO BOARD 50P	
< IC >			
@ IC603	1-789-071-21	MOUNTED PC BOARD (CXR711260-212H2)	
IC604	6-707-833-01	IC 42S16100-TTG	
IC1602	6-702-355-01	IC AK6510CL-L	
< RESISTOR/FERRITE BEAD >			
R406	1-218-990-11	SHORT CHIP	0
R407	1-218-990-11	SHORT CHIP	0
R602	1-218-990-11	SHORT CHIP	0
R603	1-218-929-11	RES-CHIP	10 5% 1/16W
R604	1-218-929-11	RES-CHIP	10 5% 1/16W
R606	1-218-990-11	SHORT CHIP	0
R608	1-218-973-11	RES-CHIP	47K 5% 1/16W
R609	1-218-969-11	RES-CHIP	22K 5% 1/16W
R610	1-218-977-11	RES-CHIP	100K 5% 1/16W
R613	1-218-990-11	SHORT CHIP	0
R614	1-218-990-11	SHORT CHIP	0
R618	1-218-953-11	RES-CHIP	1K 5% 1/16W
R621	1-218-953-11	RES-CHIP	1K 5% 1/16W
R623	1-208-911-11	METAL CHIP	10K 0.5% 1/16W
R624	1-208-911-11	METAL CHIP	10K 0.5% 1/16W
R625	1-208-911-11	METAL CHIP	10K 0.5% 1/16W
R628	1-218-957-11	RES-CHIP	2.2K 5% 1/16W
R629	1-218-957-11	RES-CHIP	2.2K 5% 1/16W
R630	1-400-461-21	FERRITE, EMI (SMD) (1005)	
R631	1-208-943-11	METAL CHIP	220K 0.5% 1/16W (ZV700: E/ZV701: E)
R632	1-218-990-11	SHORT CHIP	0
R634	1-218-965-11	RES-CHIP	10K 5% 1/16W
R635	1-218-989-11	RES-CHIP	1M 5% 1/16W
R636	1-218-977-11	RES-CHIP	100K 5% 1/16W
R637	1-218-981-11	RES-CHIP	220K 5% 1/16W
R638	1-218-969-11	RES-CHIP	22K 5% 1/16W
R639	1-218-973-11	RES-CHIP	47K 5% 1/16W
R642	1-218-973-11	RES-CHIP	47K 5% 1/16W
R644	1-218-929-11	RES-CHIP	10 5% 1/16W
R647	1-218-965-11	RES-CHIP	10K 5% 1/16W
R649	1-218-969-11	RES-CHIP	22K 5% 1/16W
R650	1-218-977-11	RES-CHIP	100K 5% 1/16W
R651	1-218-977-11	RES-CHIP	100K 5% 1/16W
R653	1-218-965-11	RES-CHIP	10K 5% 1/16W

@ Replacement of IC603 used in this set requires a special tool.

XP-ZV700/ZV701/ZV702

EGL **JACK**

Ref. No.	Part No.	Description	Remark
R655	1-218-973-11	RES-CHIP 47K 5%	1/16W
R656	1-218-977-11	RES-CHIP 100K 5%	1/16W
R669	1-218-973-11	RES-CHIP 47K 5%	1/16W
R670	1-218-990-11	SHORT CHIP 0 (ZV700: E/ZV701: E)	
< COMPOSITION CIRCUIT BLOCK >			
RB601	1-233-969-11	RES, NETWORK (CHIP TYPE) 22K	
< VARISTOR >			
VDR601	1-801-862-11	VARISTOR, CHIP (1608)	
< VIBRATOR >			
X601	1-795-392-21	VIBRATOR, CERAMIC (22MHz)	

A-1083-829-A	JACK BOARD, COMPLETE (ZV702)		
A-1083-831-A	JACK BOARD, COMPLETE (ZV700: E)		
A-1083-832-A	JACK BOARD, COMPLETE (ZV701: AEP)		
A-1083-833-A	JACK BOARD, COMPLETE (ZV700: AEP)		
A-1083-835-A	JACK BOARD, COMPLETE (ZV701: E)		

(Including EGL BOARD, COMPLETE)			
2-187-916-01	TERMINAL BOARD (+) (EXCEPT ZV700: AEP)		
2-187-916-11	TERMINAL BOARD (+) (ZV700: AEP)		
2-187-917-01	SPRING (-), COIL (EXCEPT ZV700: AEP)		
2-187-917-11	SPRING (-), COIL (ZV700: AEP)		
2-589-207-01	SHIELD, CUSHION		
2-590-110-01	INSULATING SHEET (HOLD)		
< CAPACITOR >			
C102	1-126-246-11	ELECT CHIP 220uF 20%	4V
C103	1-162-966-11	CERAMIC CHIP 0.0022uF 10%	50V
C104	1-165-884-11	CERAMIC CHIP 2.2uF 10%	6.3V
C107	1-115-467-11	CERAMIC CHIP 0.22uF 10%	10V
C108	1-115-467-11	CERAMIC CHIP 0.22uF 10%	10V
C202	1-126-246-11	ELECT CHIP 220uF 20%	4V
C203	1-162-966-11	CERAMIC CHIP 0.0022uF 10%	50V
C204	1-165-884-11	CERAMIC CHIP 2.2uF 10%	6.3V
C207	1-115-467-11	CERAMIC CHIP 0.22uF 10%	10V
C208	1-115-467-11	CERAMIC CHIP 0.22uF 10%	10V
C301	1-126-209-11	ELECT CHIP 100uF 20%	4V
C302	1-107-826-11	CERAMIC CHIP 0.1uF 10%	16V
C303	1-107-826-11	CERAMIC CHIP 0.1uF 10%	16V
C304	1-104-851-11	TANTALUM CHIP 10uF 20%	10V
C305	1-124-779-00	ELECT CHIP 10uF 20%	16V
C307	1-165-884-11	CERAMIC CHIP 2.2uF 10%	6.3V
C308	1-127-760-11	CERAMIC CHIP 4.7uF 10%	6.3V
C311	1-162-968-11	CERAMIC CHIP 0.0047uF 10%	50V
C401	1-115-156-11	CERAMIC CHIP 1uF	10V
C402	1-126-246-11	ELECT CHIP 220uF 20%	4V
C403	1-100-507-11	CERAMIC CHIP 4.7uF 20%	6.3V
C404	1-115-467-11	CERAMIC CHIP 0.22uF 10%	10V
C405	1-115-156-11	CERAMIC CHIP 1uF	10V
C406	1-107-826-11	CERAMIC CHIP 0.1uF 10%	16V
C407	1-125-837-11	CERAMIC CHIP 1uF 10%	6.3V
C409	1-137-710-11	CERAMIC CHIP 10uF 20%	6.3V

Ref. No.	Part No.	Description	Remark
C410	1-128-003-11	ELECT CHIP 22uF 20%	4V
C411	1-162-970-11	CERAMIC CHIP 0.01uF 10%	25V
C412	1-162-970-11	CERAMIC CHIP 0.01uF 10%	25V
C413	1-162-970-11	CERAMIC CHIP 0.01uF 10%	25V
C414	1-117-863-11	CERAMIC CHIP 0.47uF 10%	6.3V
C416	1-162-927-11	CERAMIC CHIP 100PF 5%	50V
C417	1-117-863-11	CERAMIC CHIP 0.47uF 10%	6.3V
C418	1-126-208-21	ELECT CHIP 47uF 20%	4V
C419	1-128-964-11	TANTALUM CHIP 100uF 20%	6.3V
C420	1-125-837-11	CERAMIC CHIP 1uF 10%	6.3V
C421	1-126-209-11	ELECT CHIP 100uF 20%	4V
C422	1-162-970-11	CERAMIC CHIP 0.01uF 10%	25V
C423	1-126-209-11	ELECT CHIP 100uF 20%	4V
C425	1-162-970-11	CERAMIC CHIP 0.01uF 10%	25V
C426	1-115-467-11	CERAMIC CHIP 0.22uF 10%	10V
C428	1-100-539-11	TANTALUM CHIP 47uF 20%	6.3V
C429	1-100-539-11	TANTALUM CHIP 47uF 20%	6.3V
C431	1-165-884-11	CERAMIC CHIP 2.2uF 10%	6.3V
C432	1-100-539-11	TANTALUM CHIP 47uF 20%	6.3V
C433	1-127-760-11	CERAMIC CHIP 4.7uF 10%	6.3V
C434	1-162-960-11	CERAMIC CHIP 220PF 10%	50V
C435	1-162-964-11	CERAMIC CHIP 0.001uF 10%	50V
C436	1-107-826-11	CERAMIC CHIP 0.1uF 10%	16V
C437	1-115-467-11	CERAMIC CHIP 0.22uF 10%	10V (ZV701: E/ZV702)
C438	1-115-467-11	CERAMIC CHIP 0.22uF 10%	10V
C439	1-125-837-11	CERAMIC CHIP 1uF 10%	6.3V
C441	1-125-837-11	CERAMIC CHIP 1uF 10%	6.3V
C442	1-162-970-11	CERAMIC CHIP 0.01uF 10%	25V
C443	1-165-884-11	CERAMIC CHIP 2.2uF 10%	6.3V
C444	1-162-964-11	CERAMIC CHIP 0.001uF 10%	50V
C501	1-162-962-11	CERAMIC CHIP 470PF 10%	50V
C502	1-162-968-11	CERAMIC CHIP 0.0047uF 10%	50V
C503	1-162-964-11	CERAMIC CHIP 0.001uF 10%	50V
C504	1-162-964-11	CERAMIC CHIP 0.001uF 10%	50V
C601	1-125-837-11	CERAMIC CHIP 1uF 10%	6.3V
C602	1-125-837-11	CERAMIC CHIP 1uF 10%	6.3V
< CONNECTOR >			
CN401	1-785-877-21	HOUSING, CONNECTOR 4P	
CN402	1-784-342-21	HOUSING, CONNECTOR 2P	
CN501	1-818-893-11	CONNECTOR, BOARD TO BOARD 50P	
CN601	1-573-352-11	CONNECTOR, FFC/FPC 12P	
< DIODE >			
D101	8-719-083-04	DIODE RSB6.8STE61	
D201	8-719-083-04	DIODE RSB6.8STE61	
D301	8-719-422-37	DIODE MA8051 (ZV701: E/ZV702)	
D302	8-719-422-37	DIODE MA8051 (ZV701: E/ZV702)	
D303	8-719-422-37	DIODE MA8051 (ZV701: E/ZV702)	
D304	8-719-422-37	DIODE MA8051	
D401	6-500-483-01	DIODE MA22D2800LS0	
D402	8-719-085-43	DIODE MA2YD2300LS0	
D403	8-719-083-60	DIODE UDZSTE-174.7B	
D404	6-500-540-01	DIODE RB521S-30FTE61	
D405	6-500-540-01	DIODE RB521S-30FTE61	
D406	6-500-483-01	DIODE MA22D2800LS0	
D407	6-500-540-01	DIODE RB521S-30FTE61	

Ref. No.	Part No.	Description	Remark	Ref. No.	Part No.	Description	Remark
D408	6-500-540-01	DIODE RB521S-30FTE61		Q409	6-550-232-01	TRANSISTOR 2SA2029T2LQ/R	(ZV701: E/ZV702)
D411	8-719-071-87	DIODE MA785- (TX), SO		Q410	8-729-602-21	TRANSISTOR 2SC4154-F	
D412	8-719-069-55	DIODE UDZSTE-175.6B				< RESISTOR >	
		< FUSE >		R101	1-216-841-11	METAL CHIP 47K 5%	1/10W
△F401	1-576-406-21	FUSE (1.4A/32V)		R102	1-216-837-11	METAL CHIP 22K 5%	1/10W
		< FERRITE BEAD/SHORT >		R103	1-216-817-11	METAL CHIP 470 5%	1/10W
FB303	1-414-813-11	FERRITE, EMI (SMD) (2012)		R104	1-218-446-11	METAL CHIP 1 5%	1/10W
FB304	1-414-553-11	FERRITE, EMI (SMD) (2012) (ZV701: E/ZV702)		R111	1-216-825-11	METAL CHIP 2.2K 5%	1/10W
FB306	1-500-234-22	BEAD, FERRITE (CHIP) (1608)(ZV701: E/ZV702)		R201	1-216-841-11	METAL CHIP 47K 5%	1/10W
FB401	1-500-451-11	FERRITE, EMI (SMD) (4516)		R202	1-216-837-11	METAL CHIP 22K 5%	1/10W
FB402	1-216-295-00	SHORT CHIP 0		R203	1-216-817-11	METAL CHIP 470 5%	1/10W
FB404	1-500-451-11	FERRITE, EMI (SMD) (4516)		R204	1-218-446-11	METAL CHIP 1 5%	1/10W
FB502	1-500-234-22	BEAD, FERRITE (CHIP) (1608)		R211	1-216-825-11	METAL CHIP 2.2K 5%	1/10W
FB601	1-414-760-21	FERRITE, EMI (SMD) (1608)		R301	1-216-809-11	METAL CHIP 100 5%	1/10W
FB602	1-414-760-21	FERRITE, EMI (SMD) (1608)		R305	1-216-864-11	SHORT CHIP 0 (ZV700/ZV701: AEP)	
FB603	1-414-760-21	FERRITE, EMI (SMD) (1608)		R402	1-216-833-11	METAL CHIP 10K 5%	1/10W (ZV701: E/ZV702)
FB604	1-414-760-21	FERRITE, EMI (SMD) (1608)		R403	1-216-861-11	METAL CHIP 2.2M 5%	1/10W
FB605	1-414-760-21	FERRITE, EMI (SMD) (1608)		R404	1-216-849-11	METAL CHIP 220K 5%	1/10W
FB606	1-414-760-21	FERRITE, EMI (SMD) (1608)		R405	1-216-841-11	METAL CHIP 47K 5%	1/10W
FB607	1-414-760-21	FERRITE, EMI (SMD) (1608)		R407	1-216-809-11	METAL CHIP 100 5%	1/10W
FB608	1-414-760-21	FERRITE, EMI (SMD) (1608)		R409	1-245-455-21	METAL CHIP 0.47 1%	1/5W (EXCEPT ZV700: AEP)
FB609	1-216-864-11	SHORT CHIP 0		R410	1-216-864-11	SHORT CHIP 0	
		< IC >		R411	1-216-841-11	METAL CHIP 47K 5%	1/10W
IC301	6-700-702-01	IC TA2152FN (EL)		R412	1-216-829-11	METAL CHIP 4.7K 5%	1/10W
IC401	6-707-304-01	IC SC901591AFR2		R413	1-216-841-11	METAL CHIP 47K 5%	1/10W
IC501	6-707-315-01	IC RT8H055C-T1		R415	1-216-841-11	METAL CHIP 47K 5%	1/10W
		< JACK >		R416	1-216-809-11	METAL CHIP 100 5%	1/10W
J301	1-818-805-11	JACK (♁) (ZV701: E/ZV702)		R417	1-216-864-11	SHORT CHIP 0	
J301	1-818-810-11	JACK (♁) (ZV700/ZV701: AEP)		R418	1-245-455-21	METAL CHIP 0.47 1%	1/5W (EXCEPT ZV700: AEP)
J402	1-816-936-41	JACK, DC (DC IN 3V)		R419	1-216-813-11	METAL CHIP 220 5%	1/10W
		< COIL >		R420	1-216-813-11	METAL CHIP 220 5%	1/10W (EXCEPT ZV700: AEP)
L101	1-400-135-11	INDUCTOR 1uH		R421	1-218-871-11	METAL CHIP 10K 0.50%	1/10W
L201	1-400-135-11	INDUCTOR 1uH		R423	1-216-809-11	METAL CHIP 100 5%	1/10W
L301	1-400-145-21	INDUCTOR 47uH		R424	1-216-849-11	METAL CHIP 220K 5%	1/10W (ZV701: E/ZV702)
L411	1-400-145-21	INDUCTOR 47uH		R425	1-216-849-11	METAL CHIP 220K 5%	1/10W (ZV701: E/ZV702)
L412	1-400-145-21	INDUCTOR 47uH		R426	1-216-853-11	METAL CHIP 470K 5%	1/10W (ZV701: E/ZV702)
L413	1-416-669-61	INDUCTOR 22uH (ZV701: E/ZV702)		R428	1-216-825-11	METAL CHIP 2.2K 5%	1/10W
L413	1-419-354-21	INDUCTOR 22uH (ZV700/ZV701: AEP)		R429	1-216-813-11	METAL CHIP 220 5%	1/10W
L414	1-428-912-21	INDUCTOR 10uH		R430	1-216-813-11	METAL CHIP 220 5%	1/10W
L415	1-469-967-21	INDUCTOR 10uH		R431	1-216-864-11	SHORT CHIP 0	
L416	1-400-317-21	INDUCTOR 100uH		R432	1-216-821-11	METAL CHIP 1K 5%	1/10W (EXCEPT ZV700: AEP)
L417	1-400-145-21	INDUCTOR 47uH		R433	1-216-837-11	METAL CHIP 22K 5%	1/10W
L501	1-469-967-21	INDUCTOR 10uH		R438	1-216-845-11	METAL CHIP 100K 5%	1/10W
		< TRANSISTOR >		R439	1-216-793-11	METAL CHIP 4.7 5%	1/10W
Q401	6-550-859-01	FET NTHD4508NT1G		R440	1-216-821-11	METAL CHIP 1K 5%	1/10W
Q402	6-550-760-01	TRANSISTOR 2SA1363-T111-1E		R441	1-216-833-11	METAL CHIP 10K 5%	1/10W
Q403	6-550-364-01	TRANSISTOR 2SD2652T106	(EXCEPT ZV700: AEP)	R442	1-216-841-11	METAL CHIP 47K 5%	1/10W
Q404	6-551-139-01	TRANSISTOR DTC115TE-TL		R443	1-216-837-11	METAL CHIP 22K 5%	1/10W
Q408	8-729-055-85	TRANSISTOR UMT1N-TN		R451	1-216-845-11	METAL CHIP 100K 5%	1/10W

The components identified by mark △ or dotted line with mark △ are critical for safety. Replace only with part number specified.

XP-ZV700/ZV701/ZV702

JACK **SWITCH**

Ref. No.	Part No.	Description	Remark		
R455	1-216-864-11	SHORT CHIP	0		
R456	1-216-845-11	METAL CHIP	100K	5%	1/10W
R457	1-216-864-11	SHORT CHIP	0		
R502	1-216-864-11	SHORT CHIP	0		
R504	1-216-857-11	METAL CHIP	1M	5%	1/10W
R507	1-216-864-11	SHORT CHIP	0		
< SWITCH >					
S501	1-572-922-11	SWITCH, SLIDE (HOLD)			
S502	1-762-805-41	SWITCH, PUSH (1 KEY) (OPEN)			
< THERMISTOR >					
TH401	1-805-719-11	THERMISTOR, POSITIVE			
< VARISTOR >					
VDR309	1-801-862-11	VARISTOR, CHIP (1608) (ZV701: E/ZV702)			
VDR401	1-801-864-21	VARISTOR, CHIP (1608)			

A-1083-828-A		SWITCH BOARD, COMPLETE			

1-829-981-11		CABLE, FLEXIBLE FLAT (12 CORE)			
< CAPACITOR >					
C1001	1-107-826-11	CERAMIC CHIP	0.1uF	10%	16V
C1002	1-107-826-11	CERAMIC CHIP	0.1uF	10%	16V
C1003	1-127-715-11	CERAMIC CHIP	0.22uF	10%	16V
C1004	1-127-715-11	CERAMIC CHIP	0.22uF	10%	16V
C1005	1-127-715-11	CERAMIC CHIP	0.22uF	10%	16V
C1006	1-127-715-11	CERAMIC CHIP	0.22uF	10%	16V
C1007	1-127-715-11	CERAMIC CHIP	0.22uF	10%	16V
C1008	1-125-891-11	CERAMIC CHIP	0.47uF	10%	10V
C1010	1-127-715-11	CERAMIC CHIP	0.22uF	10%	16V
C1011	1-127-715-11	CERAMIC CHIP	0.22uF	10%	16V
C1012	1-127-715-11	CERAMIC CHIP	0.22uF	10%	16V
< CONNECTOR >					
CN1001	1-778-171-21	CONNECTOR, FFC/FPC (ZIF) 23P			
CN1002	1-778-160-11	CONNECTOR, FFC/FPC (ZIF) 12P			
< LIQUID CRYSTAL DISPLAY >					
LCD1001	1-805-689-11	DISPLAY PANEL, LIQUID CRYSTAL			
< RESISTOR >					
R1001	1-216-821-11	METAL CHIP	1K	5%	1/10W
R1002	1-216-821-11	METAL CHIP	1K	5%	1/10W
R1003	1-216-821-11	METAL CHIP	1K	5%	1/10W
R1004	1-216-821-11	METAL CHIP	1K	5%	1/10W
R1005	1-216-821-11	METAL CHIP	1K	5%	1/10W
R1101	1-216-833-11	METAL CHIP	10K	5%	1/10W
R1102	1-216-829-11	METAL CHIP	4.7K	5%	1/10W
R1103	1-216-825-11	METAL CHIP	2.2K	5%	1/10W
R1104	1-216-837-11	METAL CHIP	22K	5%	1/10W
R1105	1-216-825-11	METAL CHIP	2.2K	5%	1/10W
R1106	1-216-829-11	METAL CHIP	4.7K	5%	1/10W
R1107	1-216-833-11	METAL CHIP	10K	5%	1/10W

Ref. No.	Part No.	Description	Remark		
R1108	1-216-837-11	METAL CHIP	22K	5%	1/10W
R1109	1-216-821-11	METAL CHIP	1K	5%	1/10W
R1110	1-216-825-11	METAL CHIP	2.2K	5%	1/10W
R1111	1-216-825-11	METAL CHIP	2.2K	5%	1/10W
R1112	1-216-837-11	METAL CHIP	22K	5%	1/10W
R1113	1-216-841-11	METAL CHIP	47K	5%	1/10W
R1114	1-216-829-11	METAL CHIP	4.7K	5%	1/10W
R1135	1-216-864-11	SHORT CHIP	0		
< SWITCH >					
S1001	1-786-650-21	SWITCH, TACTILE (GROUP -)			
S1002	1-786-650-21	SWITCH, TACTILE (GROUP+)			
S1003	1-786-650-21	SWITCH, TACTILE (◀, ▶)			
S1004	1-786-650-21	SWITCH, TACTILE (▶▶, ▶▶)			
S1005	1-786-650-21	SWITCH, TACTILE (▶▶, ENTER)			
S1007	1-786-650-21	SWITCH, TACTILE (DISPLAY, MENU)			
S1008	1-786-650-21	SWITCH, TACTILE (CHG, ■)			
(EXCEPT ZV700: AEP)					
S1008	1-786-650-21	SWITCH, TACTILE (■) (ZV700: AEP)			
S1009	1-786-650-21	SWITCH, TACTILE (▲, VOL +)			
S1010	1-786-650-21	SWITCH, TACTILE (VOL -, ▼)			
S1011	1-786-650-21	SWITCH, TACTILE (SEARCH)			
< VARISTOR >					
VDR1001	1-801-862-11	VARISTOR, CHIP (1608)			

MISCELLANEOUS					

△ 152	X-3383-995-1	OPTICAL PICK-UP (DAX-25EV)			
M401	A-1061-632-A	TABLE ASSY, TURN (SPINDLE)			
M402	A-1061-630-A	MOTOR ASSY, SLED			

ACCESSORIES					

△	1-569-007-12	ADAPTOR, CONVERSION 2P (ZV700: E33)			
	2-348-288-11	MANUAL, INSTRUCTION (ENGLISH)			
	2-348-288-21	MANUAL, INSTRUCTION (FRENCH, SPANISH)			
(EXCEPT ZV700: E18/ZV701: E18)					
	2-348-288-31	MANUAL, INSTRUCTION			
(GERMAN, ITALIAN, HUNGARIAN)					
(ZV700: AEP/ZV701: AEP/ZV702)					
	2-348-288-41	MANUAL, INSTRUCTION			
(POLISH, CZECH, RUSSIAN)					
(ZV700: AEP/ZV701: AEP/ZV702)					
	2-348-288-51	MANUAL, INSTRUCTION			
(SIMPLIFIED CHINESE)					
(ZV700: E18/ZV701: E18)					
	2-348-289-11	MANUAL (SS), INSTRUCTION			
(Installation/Operating Guide) (ENGLISH)					
	2-348-289-21	MANUAL (SS), INSTRUCTION			
(Installation/Operating Guide) (SPANISH)					
(EXCEPT ZV700: E18/ZV701: E18)					
	2-348-289-31	MANUAL (SS), INSTRUCTION			
(Installation/Operating Guide) (FRENCH)					
(ZV700: AEP/ZV701: AEP/ZV702)					
	2-348-289-41	MANUAL (SS), INSTRUCTION			
(Installation/Operating Guide)					
(GERMAN, ITALIAN, HUNGARIAN)					
(ZV700: AEP/ZV701: AEP/ZV702)					

The components identified by mark △ or dotted line with mark △ are critical for safety. Replace only with part number specified.

Ref. No.	Part No.	Description	Remark
	2-348-289-51	MANUAL (SS), INSTRUCTION (Installation/Operating Guide) (POLISH, CZECH, RUSSIAN) (ZV700: AEP/ZV701: AEP/ZV702)	
	2-348-289-61	MANUAL (SS), INSTRUCTION (Installation/Operating Guide) (SIMPLIFIED CHINESE) (ZV700: E18/ZV701: E18)	
△ 501	1-478-848-11	ADAPTOR, AC (AC-ES3010K2) (ZV700: E18/ZV701/ZV702)	
△ 501	1-478-853-12	ADAPTOR, AC (AC-ES3010K2) (ZV700: E33)	
502	1-542-514-13	HEADPHONE (HP-M070) (for BLACK) (ZV700: E18)	
502	1-542-514-21	HEADPHONE (HP-M070) (for WHITE) (ZV700: E18)	
502	1-542-529-21	HEADPHONE (HP-M170) (for WHITE)(ZV701: E)	
503	8-912-734-90	EARPHONES HP-SC021SP/WC SET (for WHITE) (ZV702)	
503	8-912-737-90	EARPHONES HP-SC021LP/WC SET (for WHITE) (ZV700: E33, AEP/ZV701: AEP)	
503	8-912-739-90	HEADPHONE HP-SC021SP/BC SET (for BLACK) (ZV702)	
503	8-912-740-90	HEADPHONE HP-SC021LP/BC SET (for BLACK) (ZV700: E33, AEP/ZV701: AEP)	
504	1-478-544-11	REMOTE COMMANDER (RM-Z1C006) (for BLACK) (ZV702)	
504	1-478-544-21	REMOTE COMMANDER (RM-Z1C006) (for WHITE) (ZV701: E18/ZV702)	
505	1-543-798-31	FILTER, CLAMP (FERRITE CORE) (ZV700: AEP)	
506	1-756-317-22	BATTERY, NICKEL HYDROGEN (NH-7WMAA) (ZV701: E18)	
507	3-223-571-01	CASE, BATTERY CARRYING (ZV701: E18)	
508	X-2055-011-1	APPLICATION (SS2.3) (CD-ROM) ASSY (SonicStage)(in envelope)	
508	X-2055-012-1	APPLICATION (SS2.3) (CD-ROM) ASSY (SonicStage)(in polyethylene bag)	

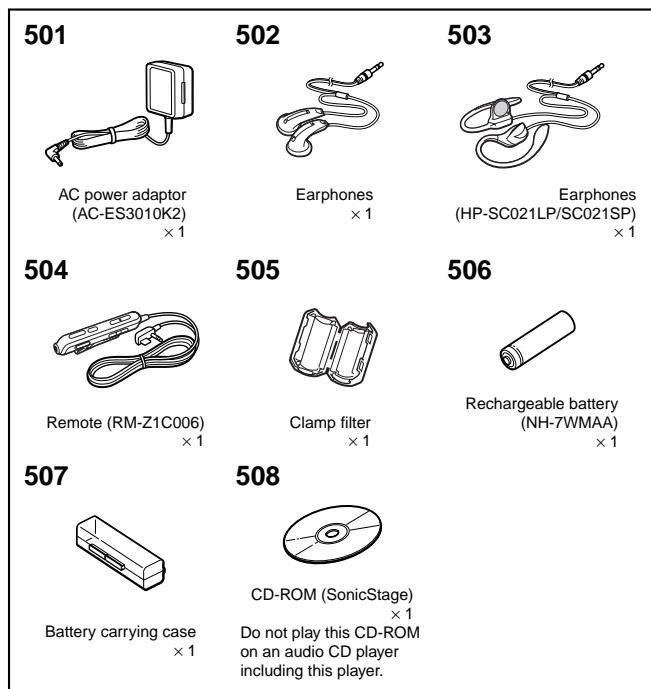

The components identified by mark △ or dotted line with mark △ are critical for safety. Replace only with part number specified.

