

XP-ZV71/ZV71C/ZV77/ ZV77C/ZV77D

SERVICE MANUAL

Ver 1.3 2003.12



Photo : XP-ZV77

US Model
XP-ZV71/ZV71C

Canadian Model
XP-ZV77

AEP Model
XP-ZV77/ZV77D

UK Model
XP-ZV77

E Model
XP-ZV77/ZV77C/ZV77D

Australian Model
XP-ZV77

Chinese Model
XP-ZV77D

Model Name Using Similar Mechanism	D-EJ760
CD Mechanism Type	CDM-3325ER
Optical Pick-up Name	DAX-25E

SPECIFICATIONS

System

Compact disc digital audio system

Laser diode properties

Material: GaAlAs

Wavelength: $\lambda = 780 \text{ nm}$

Emission duration: Continuous

Laser output: Less than $44.6 \mu\text{W}$

(This output is the value measured at a distance of 200 mm from the objective lens surface on the optical pick-up block with 7 mm aperture.)

D-A conversion

1bit DAC

Frequency response

20 – 20 000 Hz $\pm 1/2$ dB (measured by JEITA CP-307)

Power requirements

- Two Ni-MH rechargeable batteries (size AA, 700 mAh): 2.4 V DC
- Two LR6 (size AA) batteries: 3 V DC
- AC power adaptor (DC IN 4.5 V jack): 120 V, 60 Hz

Battery life* (approx. hours)

(When you use the CD player on a flat and stable surface.)

Playing time varies depending on how the CD player is used.

Using two Sony alkaline batteries LR6 (SG) (produced in Japan)

	EASS 1	EASS 2
Audio disc	30	26
MP3 disc	—	32

* Measured value by the standard of JEITA (Japan electronics and Information Technology Industries Association).

Operating temperature

5°C – 35°C (41°F – 95°F)

Dimensions (w/h/d) (excluding projecting parts and controls)

Approx. 136 × 22.7 × 139 mm
(5 $\frac{3}{8}$ × 29/32 × 5 $\frac{1}{2}$ in.)

Mass (excluding accessories)

Approx. 222 g (7.8 oz)

Design and specifications are subject to change without notice.

PORTABLE CD PLAYER

9-877-193-04
2003L16-1
© 2003.12

Sony Corporation
Personal Audio Company
Published by Sony Engineering Corporation



TABLE OF CONTENTS

1. SERVICING NOTE 3

2. GENERAL 6

3. DISASSEMBLY 7

3-1. Lower Cabinet Section 8

3-2. CD Mechanism Section (CDM-3325ER) 9

3-3. Cabinet (front) Sub Assy 10

3-4. Upper Lid Sub Assy 11

3-5. MAIN Board 12

3-6. Optical Pick-up (DAX-25E) 12

4. ELECTRICAL CHECKING 13

5. DIAGRAMS 14

5-1. Block Diagram 15

5-2. Printed Wiring Board – MAIN Board (Side A) – 16

5-3. Printed Wiring Board – MAIN Board (Side B) – 17

5-4. Printed Wiring Board – LID Board – 18

5-5. Schematic Diagram – MAIN Board (1/4) – 19

5-6. Schematic Diagram – MAIN Board (2/4),
LID Board – 20

5-7. Schematic Diagram – MAIN Board (3/4) – 21

5-8. Schematic Diagram – MAIN Board (4/4) – 22

5-9. IC Block Diagrams 23

5-10. IC Pin Function Descriptions 24

6. EXPLODED VIEWS

6-1. Cabinet (upper) Section 26

6-2. Cabinet (lower) Section 27

6-3. CD Mechanism Deck Section (CDM-3325ER) 28

7. ELECTRICAL PARTS LIST 29

This appliance is classified as a CLASS 1 LASER product. The CLASS 1 LASER PRODUCT MARKING is located on the rear exterior.

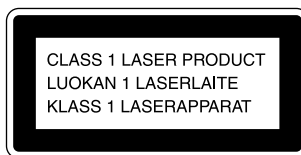

CAUTION
Use of controls or adjustments or performance of procedures other than those specified herein may result in hazardous radiation exposure.

Flexible Circuit Board Repairing

- Keep the temperature of the soldering iron around 270 °C during repairing.
- Do not touch the soldering iron on the same conductor of the circuit board (within 3 times).
- Be careful not to apply force on the conductor when soldering or unsoldering.

Notes on chip component replacement

- Never reuse a disconnected chip component.
- Notice that the minus side of a tantalum capacitor may be damaged by heat.

On AC power adaptor

- Use only the commercially-available AC power adaptor whose rated output is 4.5 V DC, 500 mA. Do not use any other AC power adaptor. It may cause a malfunction.

Polarity of the plug



SAFETY-RELATED COMPONENT WARNING!!

COMPONENTS IDENTIFIED BY MARK \triangle OR DOTTED LINE WITH MARK \triangle ON THE SCHEMATIC DIAGRAMS AND IN THE PARTS LIST ARE CRITICAL TO SAFE OPERATION. REPLACE THESE COMPONENTS WITH SONY PARTS WHOSE PART NUMBERS APPEAR AS SHOWN IN THIS MANUAL OR IN SUPPLEMENTS PUBLISHED BY SONY.

ATTENTION AU COMPOSANT AYANT RAPPORT À LA SÉCURITÉ!

LES COMPOSANTS IDENTIFÉS PAR UNE MARQUE \triangle SUR LES DIAGRAMMES SCHÉMATIQUES ET LA LISTE DES PIÈCES SONT CRITIQUES POUR LA SÉCURITÉ DE FONCTIONNEMENT. NE REMPLACER CES COMPOSANTS QUE PAR DES PIÈCES SONY DONT LES NUMÉROS SONT DONNÉS DANS CE MANUEL OU DANS LES SUPPLÉMENTS PUBLIÉS PAR SONY.

SECTION 1 SERVICING NOTE

NOTES ON HANDLING THE OPTICAL PICK-UP BLOCK OR BASE UNIT

The laser diode in the optical pick-up block may suffer electrostatic breakdown because of the potential difference generated by the charged electrostatic load, etc. on clothing and the human body. During repair, pay attention to electrostatic breakdown and also use the procedure in the printed matter which is included in the repair parts.

The flexible board is easily damaged and should be handled with care.

NOTES ON LASER DIODE EMISSION CHECK

The laser beam on this model is concentrated so as to be focused on the disc reflective surface by the objective lens in the optical pick-up block. Therefore, when checking the laser diode emission, observe from more than 30 cm away from the objective lens.

BEFORE REPLACING THE OPTICAL PICK-UP BLOCK

Please be sure to check thoroughly the parameters as per the "Optical Pick-Up Block Checking Procedures" (Part No.: 9-960-027-11) issued separately before replacing the optical pick-up block.

LASER DIODE AND FOCUS SEARCH OPERATION CHECK

During normal operation of the equipment, emission of the laser diode is prohibited unless the upper lid is closed while turning ON the S301. (push switch type)

The following checking method for the laser diode is operable.

• Method:

Emission of the laser diode is visually checked.

1. Open the upper lid.
2. With a disc not set, turn on the S301 with a screwdriver having a thin tip as shown in Fig.1.
3. Press the  button.
4. Observing the objective lens, check that the laser diode emits light.

When the laser diode does not emit light, automatic power control circuit or optical pickup is faulty.

In this operation, the objective lens will move up and down 4 times along with inward motion for the focus search.

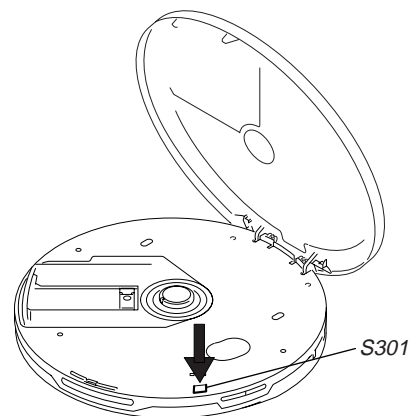

Fig. 1 Method to push the S301

SERVICE MODE

The following confirmation can be performed when the Service Mode is set.

1. How to set the Service Mode.

To set the Service Mode, the following method is available.

- 1) Confirm the set is not powered on.
- 2) Confirm the following settings.
 Solder Land (SL301) SHORT
 [HOLD] switch (S309) OFF
- 3) Short the solder land SL302 (TEST) on the MAIN board.
- 4) Turn on the main power.

– MAIN Board (SIDE A) –

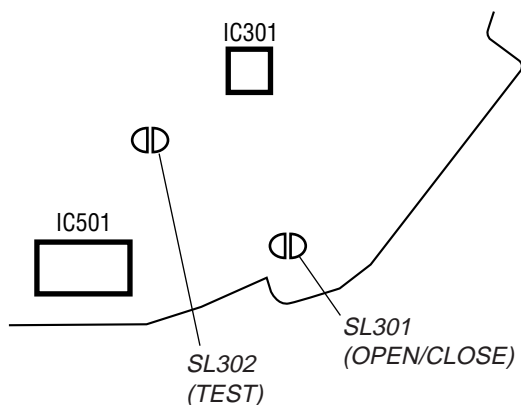

2. Operation when the Service Mode is set.

When the Service Mode becomes active, “READING” is displayed and then TOC of the CD is displayed.
 If CD is not set, “ERROR” is displayed and LCD on the remote control is lit off.

3. Operations by buttons or Rotary control in the Service Mode (Stop status)[TOC is displayed]

The following confirmations can be performed by operating buttons (on the CD player or the remote control) or Rotary control.

• SLED Movement Mode

By pressing the [▶▶] / [◀◀] button on the set or the [▶▶] / [◀◀] button on the remote control for few seconds, the optical pick-up is moved to outside or inside.
 (LCD display on the remote control is not changed.)

Note : Be sure to keep your eyes apart from the direct emission of the Laser diode.
 Do not move the optical pick-up over outermost or innermost.

• CD-DA/RW Change Over Function

By short pressing the [▶▶] button on the set or the [▶▶] button on the remote control, the terminal control for gain control is changed and gain for playing of CD-DA or CD-RW is changed over.
 (LCD display on the remote control is not changed.)

• Focus Search Mode

By short pressing the [VOL+] button on the set or the [VOL+] button on the remote control, focus search is performed.

• Laser ON/OFF Selection Function

By short pressing the [VOL-] button on the set or the [VOL-] button on the remote control, laser is switched on or off.
Note : Be sure to keep your eyes apart from the direct emission of the Laser diode.

• Menu Mode

By short pressing the [■] button on the set or the [■] button on the remote control, the Menu mode is activated. The menu mode is not used for service, therefore press the [■] button on the set or the [■] button on the remote control for short time to exit this mode. (TOC is displayed)

4. Operations by buttons or Rotary control in the Service Mode (Play status)

Note : [▶▶] / [■] / [▶▶] / [◀◀] buttons are available.

• Tracking/Sled Servo ON/OFF Change Over Function

By short pressing the [VOL+] button on the set or the [VOL+] button on the remote control during play back, Tracking/Sled Servo is switched on or off.
 (Track number is displayed on the LCD display.)

• **Microcomputer Halt Function**

By short pressing the **[VOL-]** button on the set or the **[VOL-]** button on the remote control during play back, the operation of the microcomputer is stopped.

After the microcomputer stopped, any key operation or display operation is not performed. Communication with the DSP is not performed. This mode is used only for checking the operation/function of servo.

(LCD on the remote control is lit off)

Note : To exit this mode , switch off and then switch on.

5. How to exit the Service Mode

- 1) Turn off the power.
- 2) Open the solder land SL302 (TEST) on the MAIN board.

Note : The solder should be removed clean.

This section is extracted from instruction manual.

Locating the controls

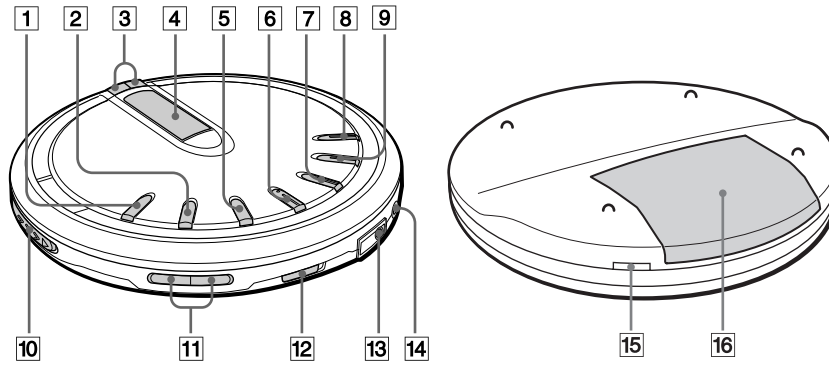

- 1 P-MODE/↩ button
 - 2 SOUND button
 - 3 FOLDER SKIP - /+ buttons
 - 4 Display
 - 5 DISPLAY buttons
 - 6 ca /ENTER button*
 - 7 s /OFF/CHARGE button
 - 8 r button
 - 9 t button
 - 0 OPEN switch
 - ! VOL + */- switch
 - @ HOLD switch
 - # \ (headphones) jack
 - § DC IN 4.5V jack
- ⊗ Hand strap hole
 - > Battery compartment
- * The button has a tactile dot.

SECTION 3 DISASSEMBLY

Note : Disassemble the unit in the order as shown below.

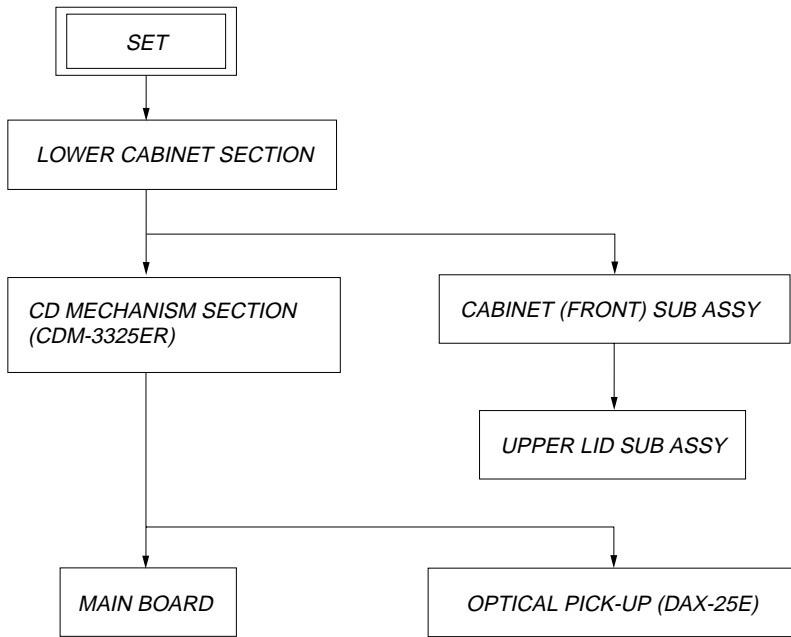

Note : Follow the disassembly procedure in the numerical order given.

3-1. Lower Cabinet Section

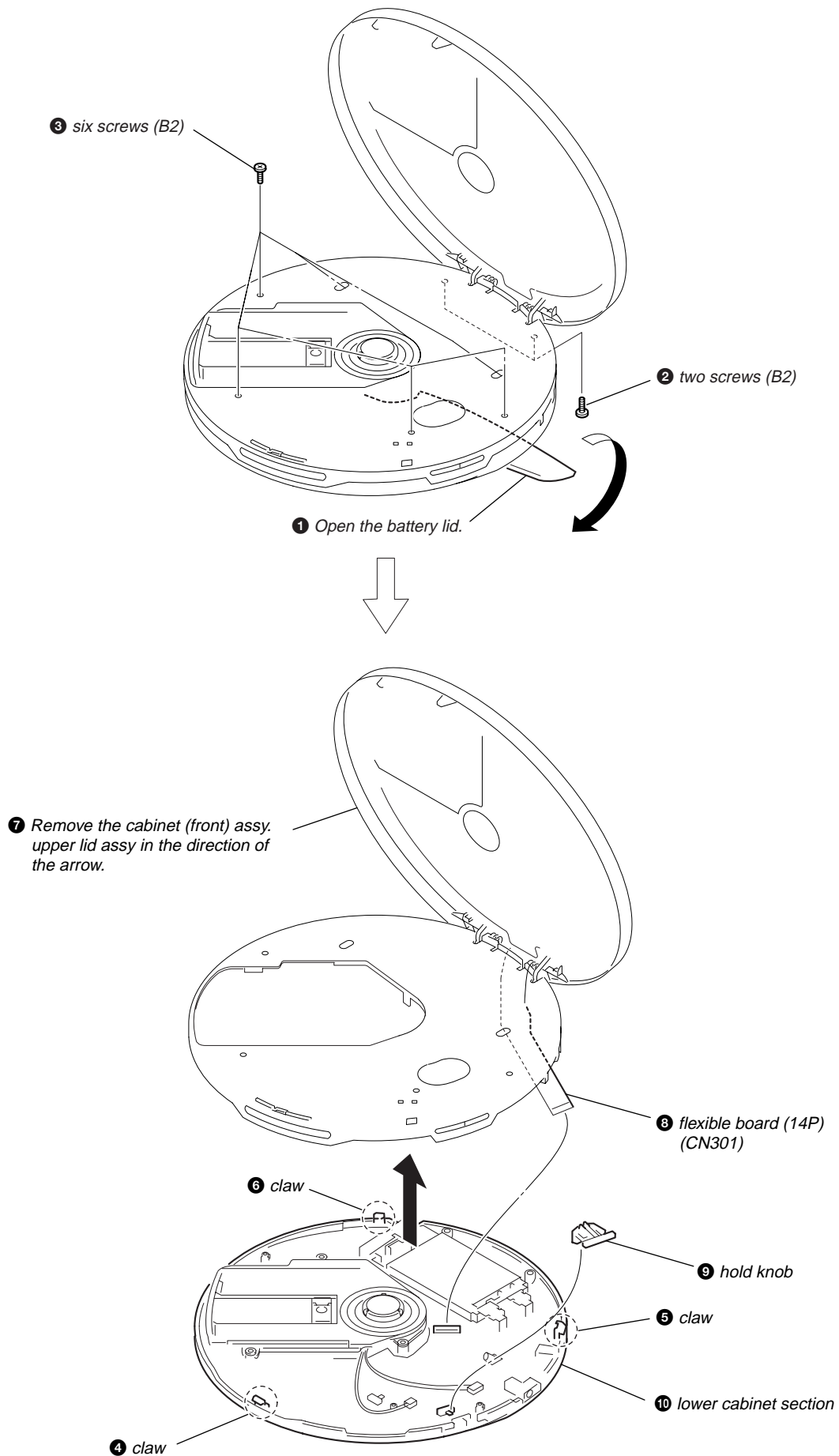

3-2. CD Mechanism Section (CDM-3325ER)

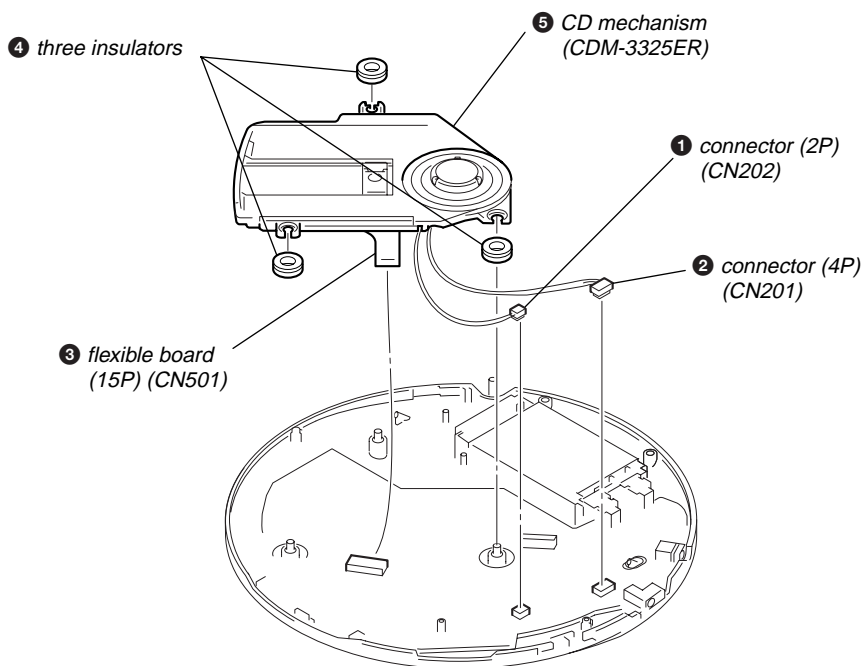

3-3. Cabinet (front) Sub Assy

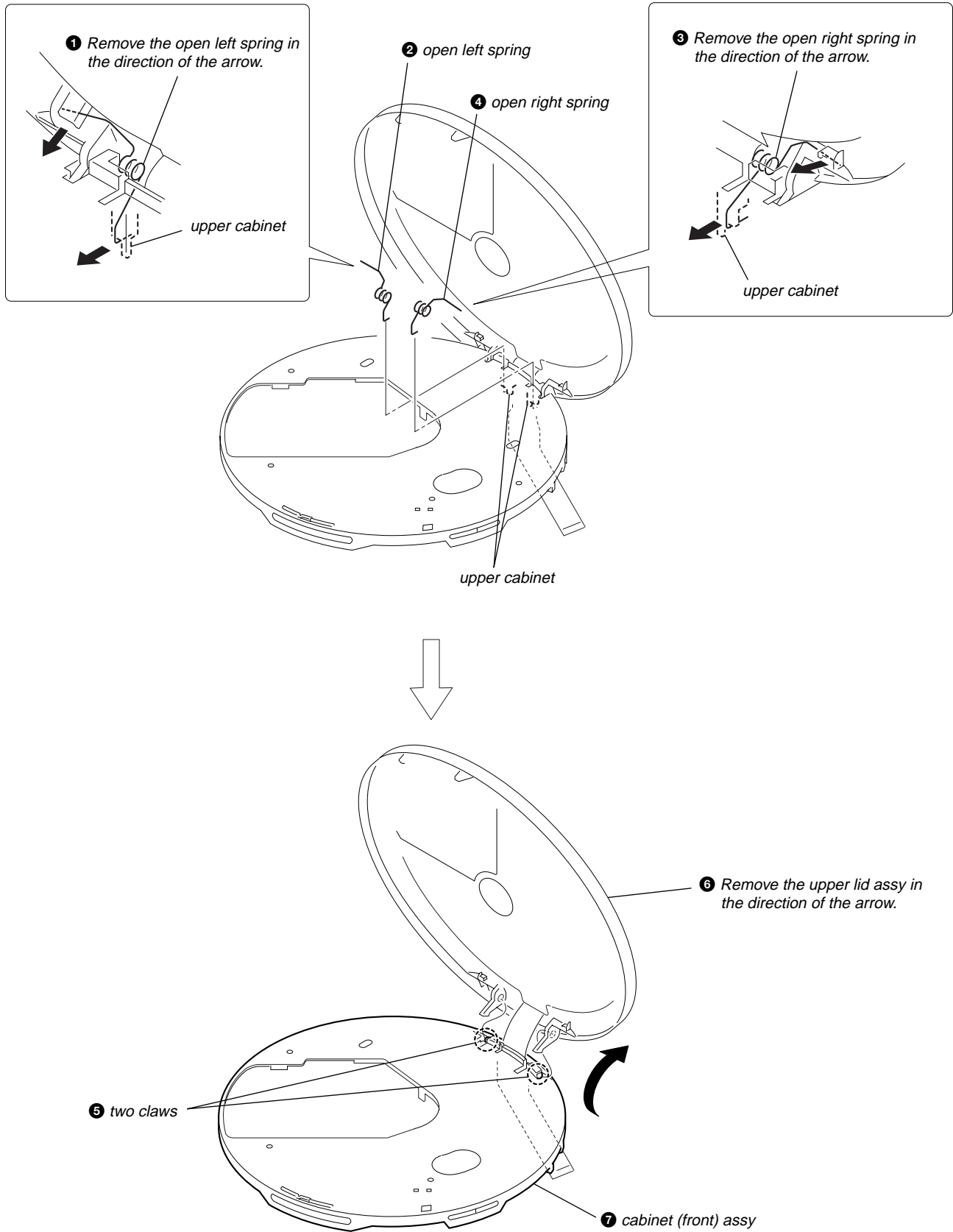

3-4. Upper Lid Sub Assy

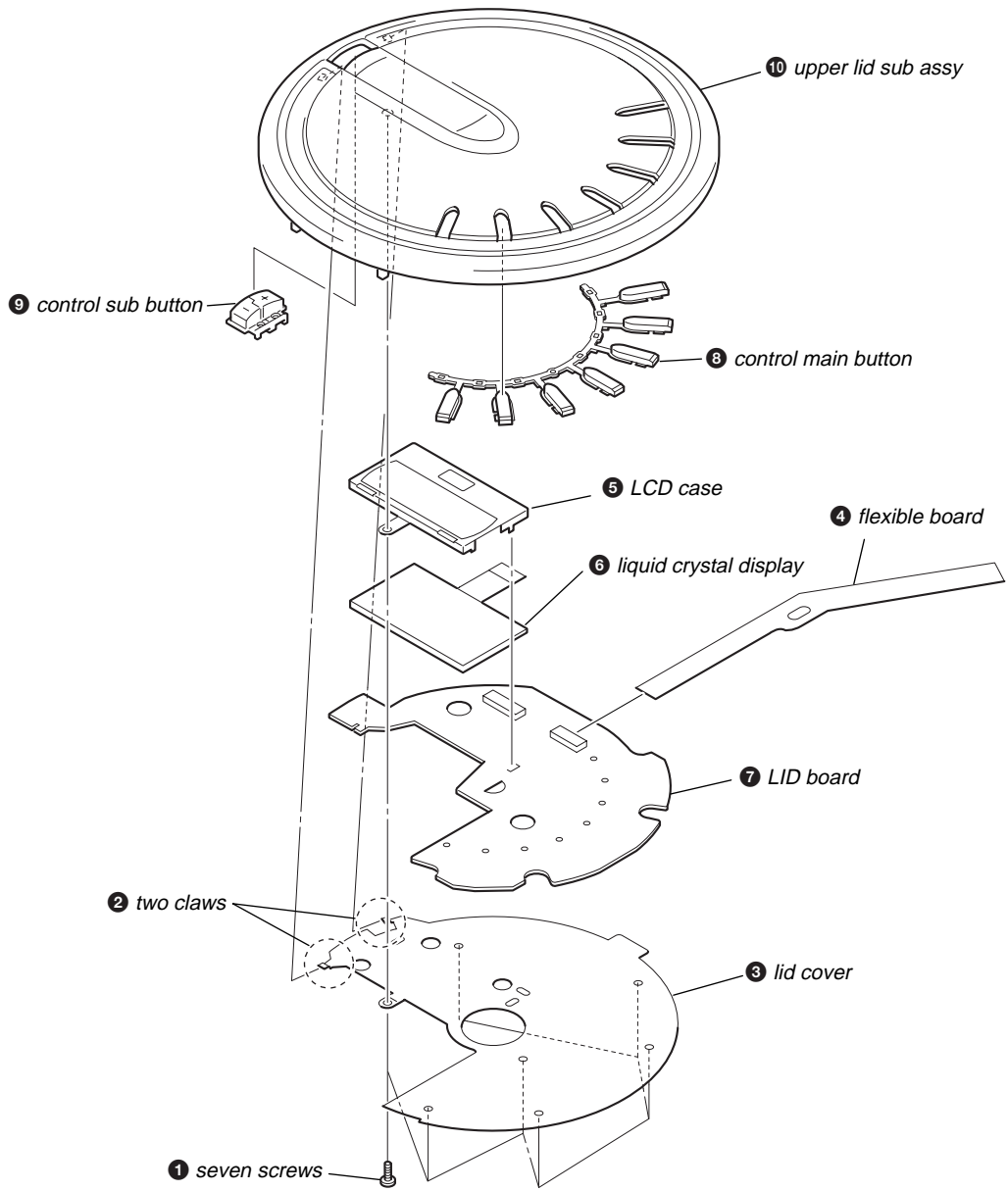

3-5. MAIN Board

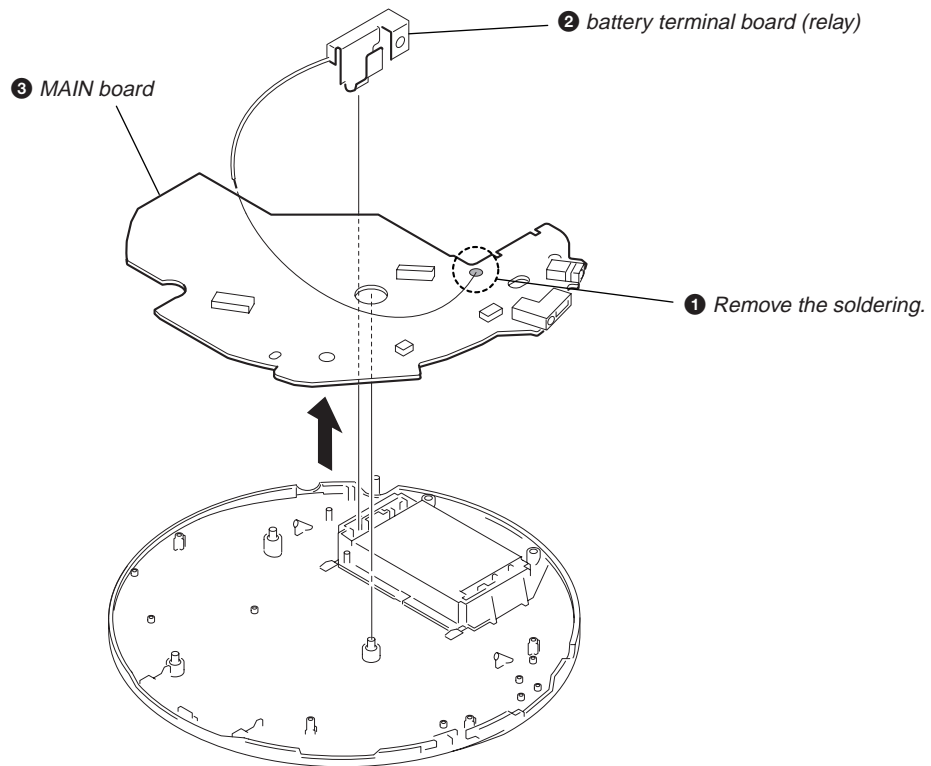

3-6. Optical Pick-up (DAX-25E)

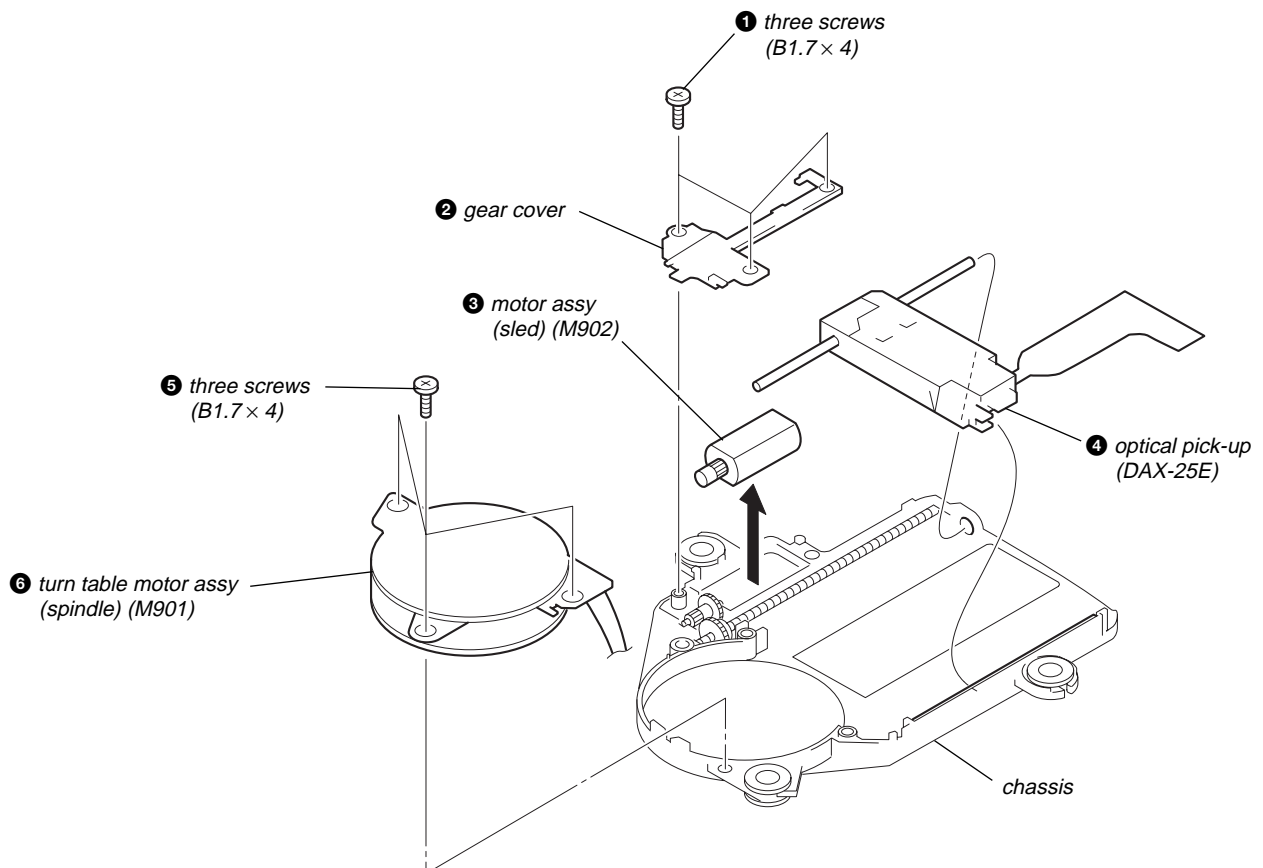

SECTION 4 ELECTRICAL CHECKING

The CD section adjustments are done automatically in this set.
In case of operation check, confirm that RF level.

Precautions for Check

1. Perform check in the order given.
2. Use YEDS-18 disc (Part No.: 3-702-101-01) unless otherwise indicated.
3. Power supply voltage requirement : DC4.5 V in DC IN jack.

(J101)

VOLUME button : Minimum
HOLD switch : OFF

Checking Location:

– MAIN board (SIDE A) –

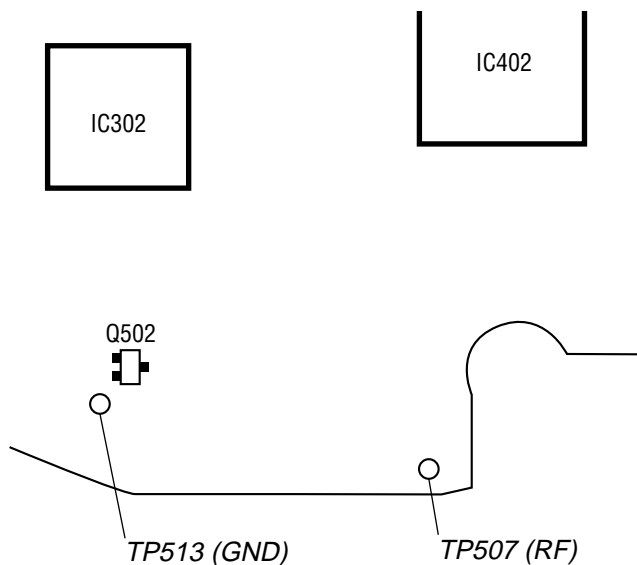

RF Level Check

Condition:

- Hold the set in horizontal state.

Connection:

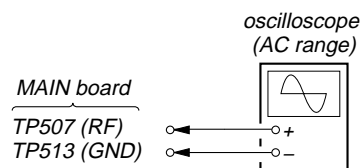

Procedure:

1. Connect the oscilloscope to the test points TP507 (RF) and TP513 (GND) on the MAIN board.
2. Set a disc. (YEDS-18)
3. Press the button.
4. Check the oscilloscope waveform is as shown below.
A good eye pattern means that the diamond shape (◊) in the center of the waveform can be clearly distinguished.

RF Signal reference Waveform (Eye Pattern)

VOLT/DIV : 100 mV (With the 10:1 probe in use)
TIME/DIV : 500 ns

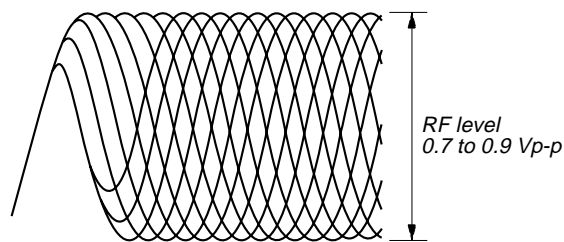

To watch the eye pattern, set the oscilloscope to AC range and increase the vertical sensitivity of the oscilloscope for easy watching.

5. Stop revolving of the disc motor by pressing the button.

NOTE FOR PRINTED WIRING BOARDS AND SCHEMATIC DIAGRAMS

Note on Printed Wiring Board

- — : parts extracted from the component side.
- : parts extracted from the conductor side.
- : Pattern from the side which enables seeing.
(The other layers' patterns are not indicated.)

Caution:
 Pattern face side: Parts on the pattern face side seen from the pattern face are indicated.
 Parts face side: Parts on the parts face side seen from the parts face are indicated.

- MAIN board is multi-layer printed board. However, the patterns of intermediate-layer have not been included in the diagram.

Note on Schematic Diagram:

- All capacitors are in μF unless otherwise noted. pF: μF 50 WV or less are not indicated except for electrolytics and tantalums.
- All resistors are in Ω and $\frac{1}{4} \text{W}$ or less unless otherwise specified.
- % : indicates tolerance.
- : panel designation.

<p>Note: The components identified by mark \triangle or dotted line with mark \triangle are critical for safety. Replace only with part number specified.</p>	<p>Note: Les composants identifiés par une marque \triangle sont critiques pour la sécurité. Ne les remplacer que par une pièce portant le numéro spécifié.</p>
--	---

- : B+ Line.
- Total current is measured with CD installed.
- Power voltage is dc 4.5 V and fed with regulated dc power supply from DC IN jack (J101).
- Voltages and waveforms are dc with respect to ground in playback mode.
no mark : CD PLAY
- Voltages are taken with a VOM (Input impedance 10 M Ω).
Voltage variations may be noted due to normal production tolerances.
- Waveforms are taken with a oscilloscope.
Voltage variations may be noted due to normal production tolerances.
- Circled numbers refer to waveforms.
- Signal path.
⇒ : CD PLAY (ANALOG OUT)
- Abbreviation
 CH : Chinese model
 KR : Korean model
 HK : Hong Kong model
 TW : Taiwan model
 E18 : 100-240V AC Area in E model

• WAVEFORMS

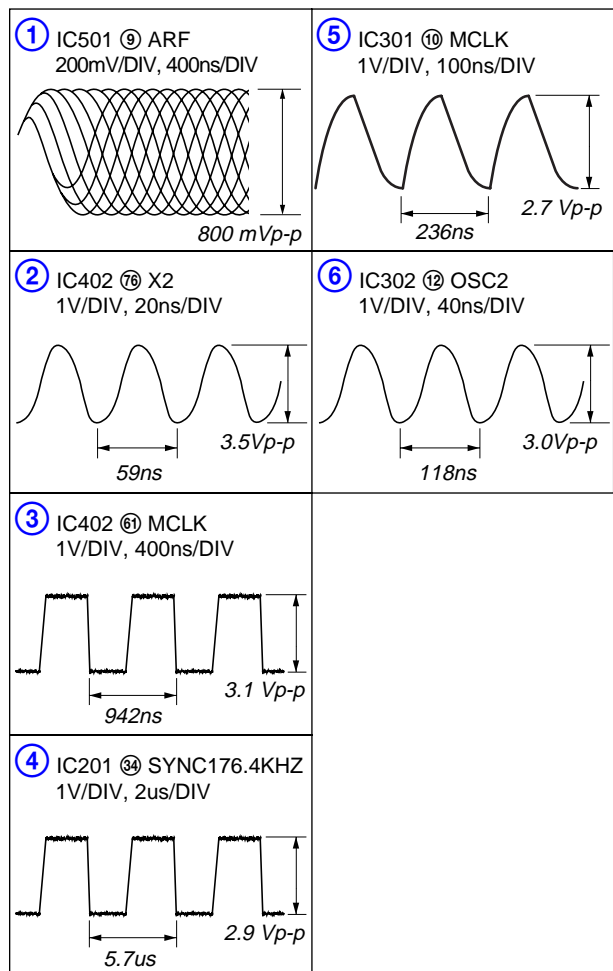

5-1. Block Diagram

OPTICAL PICK-UP BLOCK (DAX-25E)

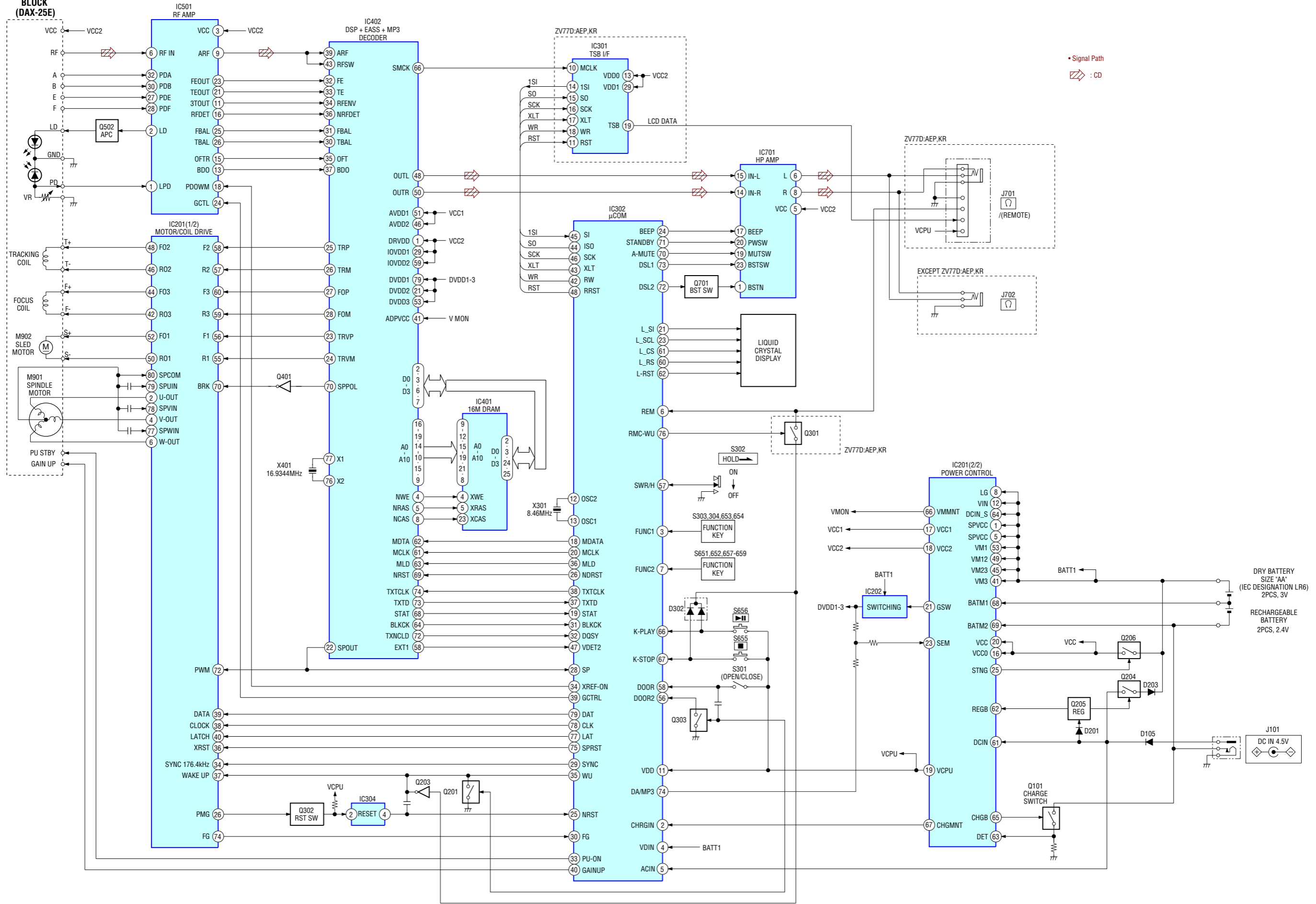

5-2. Printed Wiring Board – MAIN Board (Side A) –

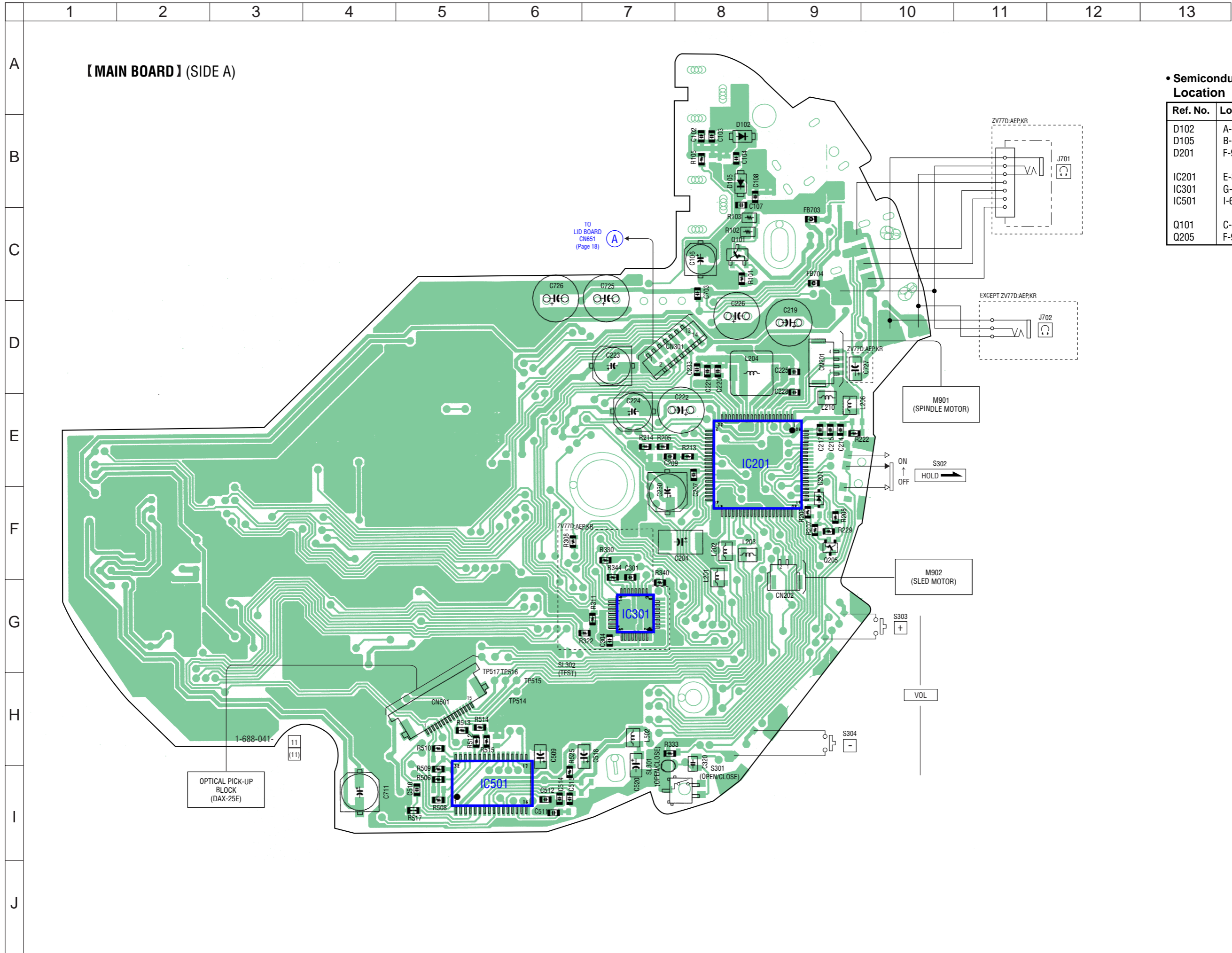

• Semiconductor Location

Ref. No.	Location
D102	A-8
D105	B-8
D201	F-9
IC201	E-8
IC301	G-7
IC501	I-6
Q101	C-8
Q205	F-9

5-3. Printed Wiring Board – MAIN Board (Side B) –

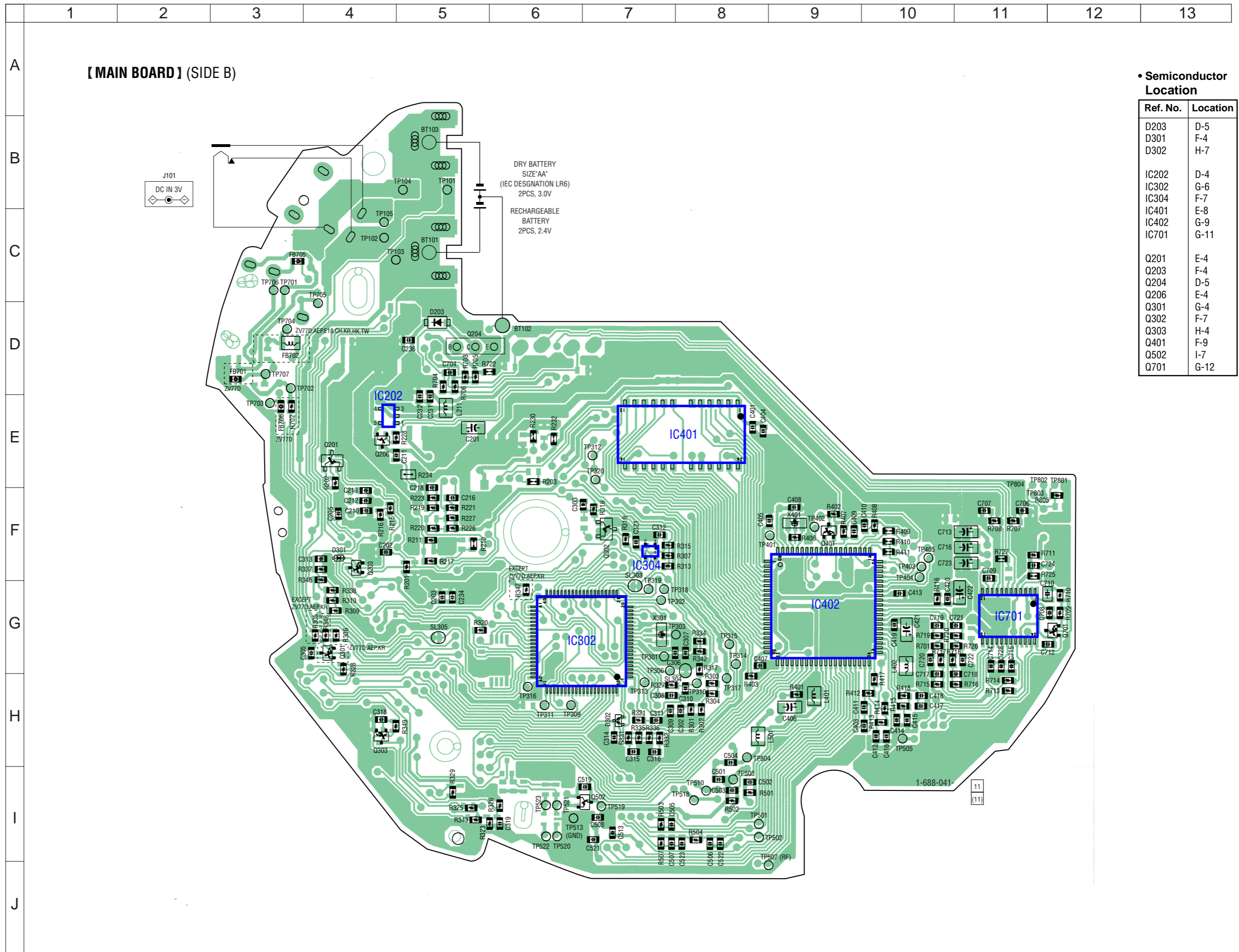

• Semiconductor Location

Ref. No.	Location
D203	D-5
D301	F-4
D302	H-7
IC202	D-4
IC302	G-6
IC304	F-7
IC401	E-8
IC402	G-9
IC701	G-11
Q201	E-4
Q203	F-4
Q204	D-5
Q206	E-4
Q301	G-4
Q302	F-7
Q303	H-4
Q401	F-9
Q502	I-7
Q701	G-12

5-4. Printed Wiring Board – LID Board –

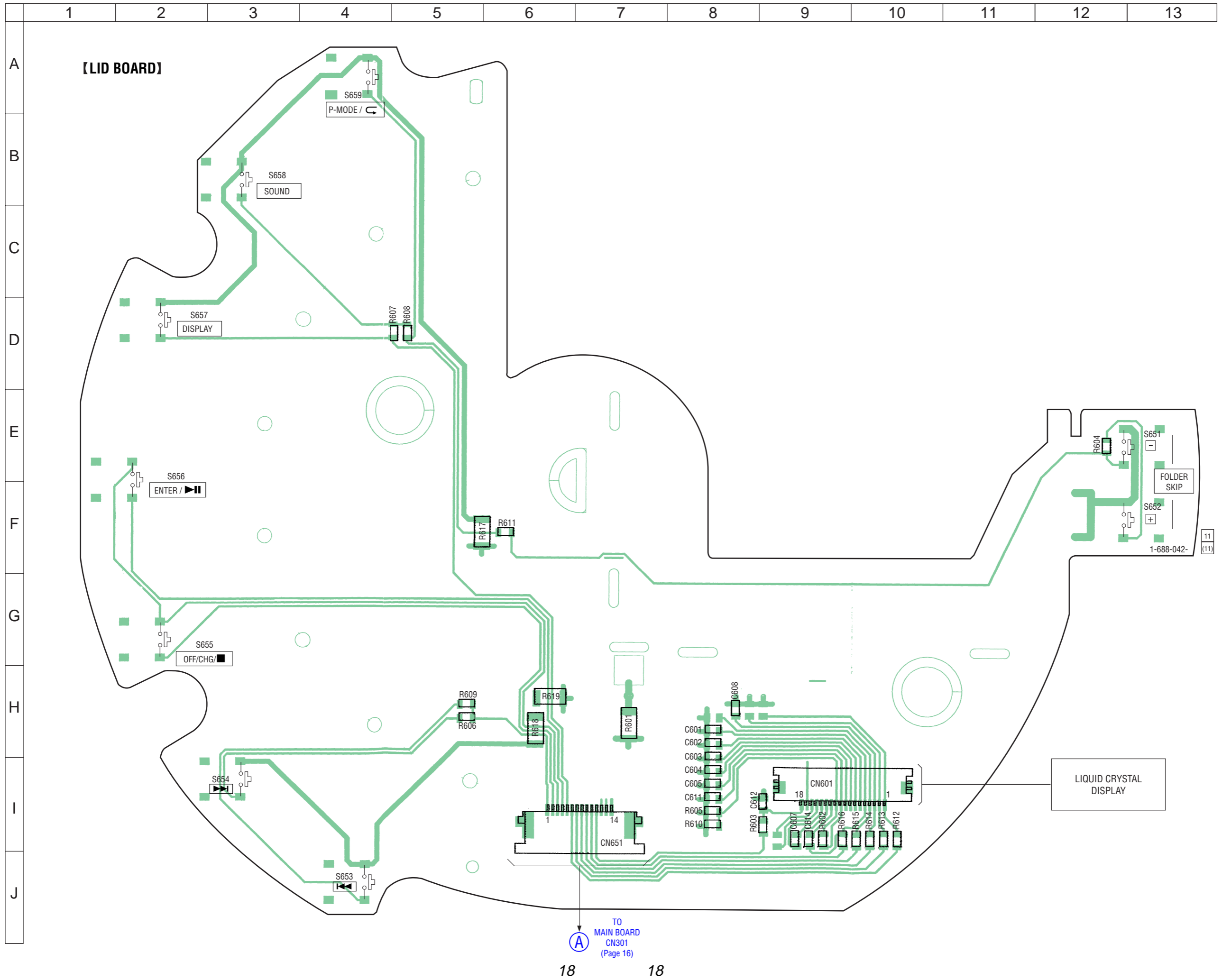

5-5. Schematic Diagram – MAIN Board (1/4) – • See page 14 for Waveforms. • See page 23 for IC Block Diagram.

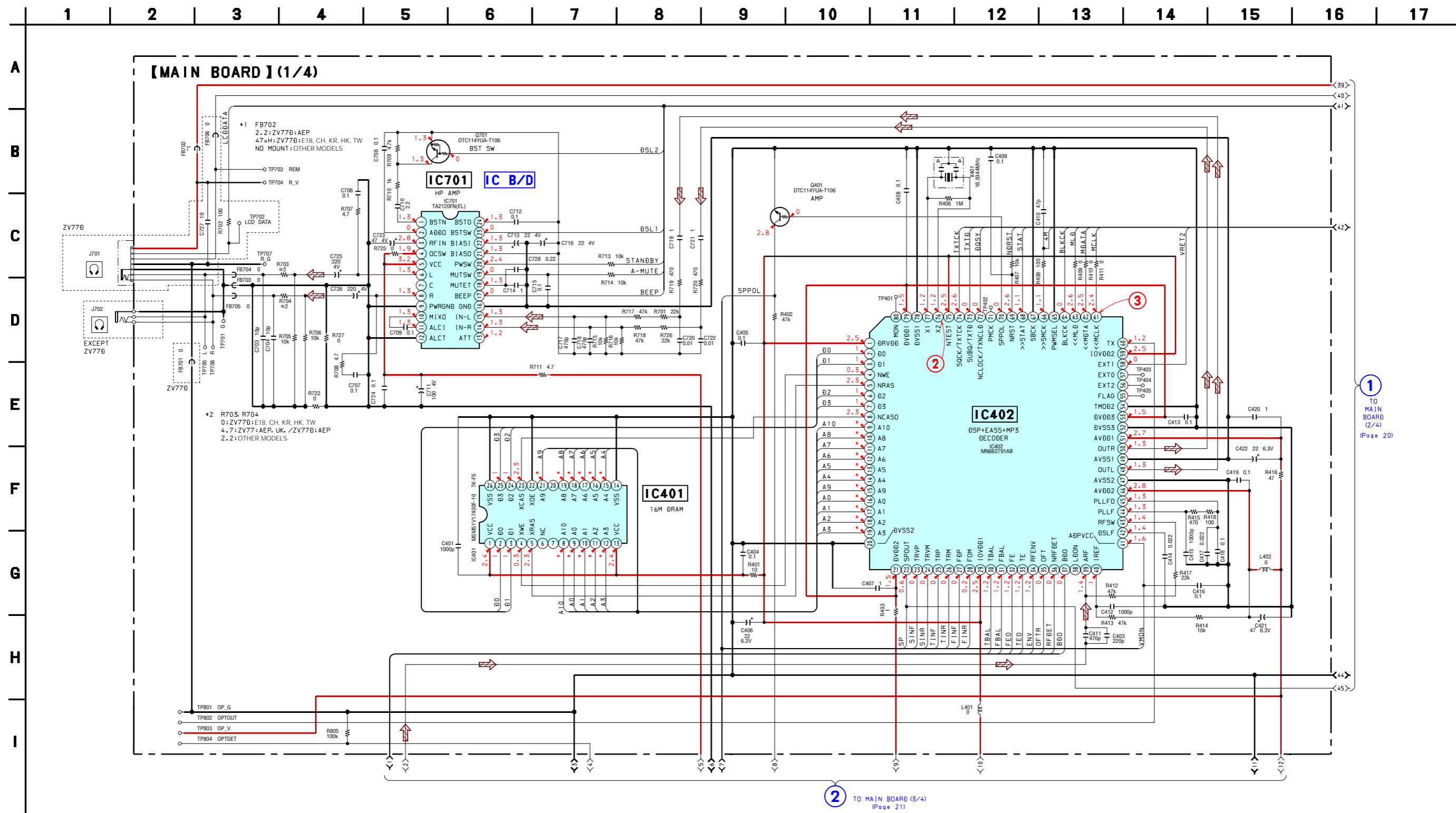

1
TO MAIN BOARD (2/4)
(Page 20)

2 TO MAIN BOARD (3/4)
(Page 21)

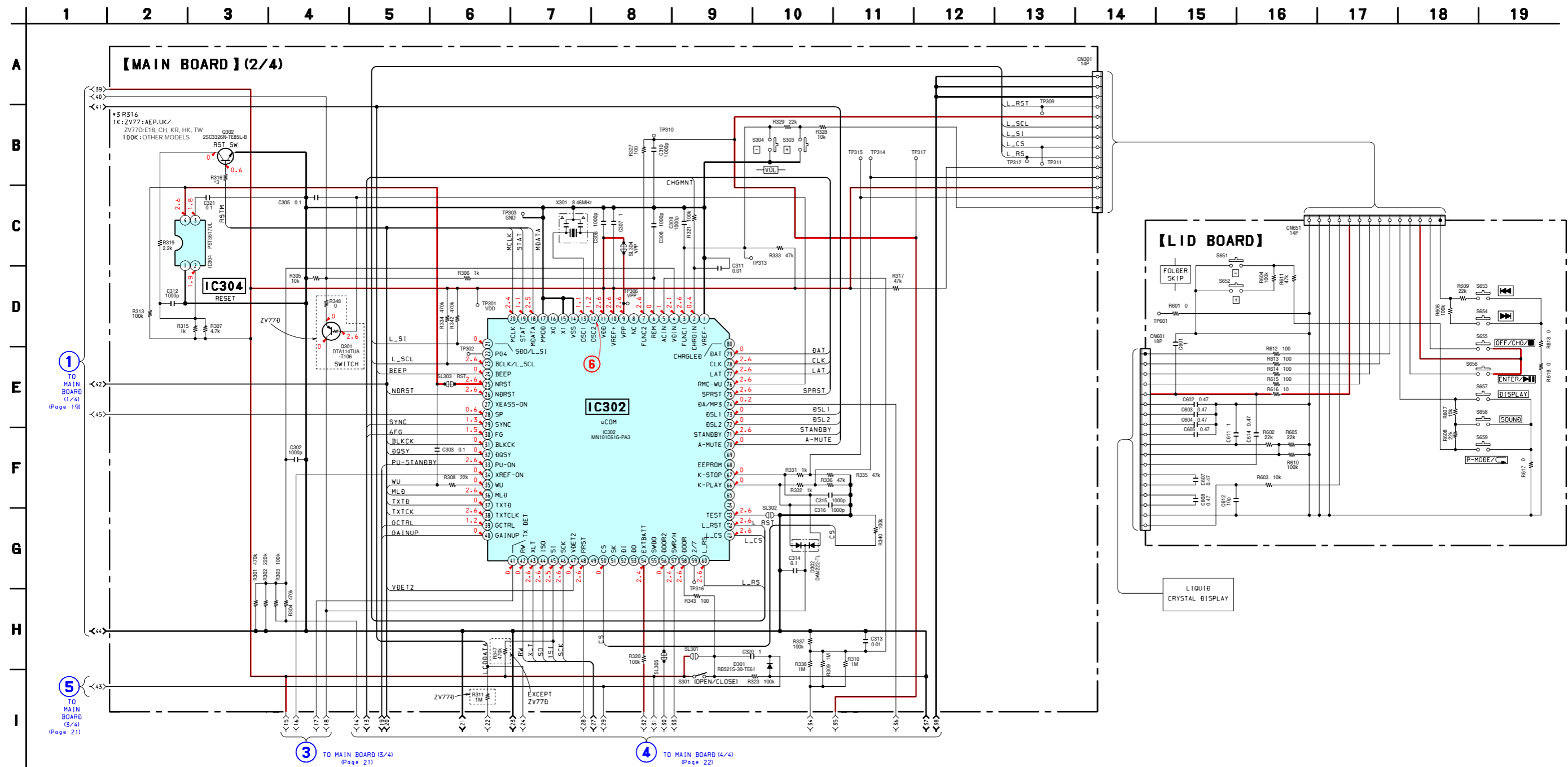

5-7. Schematic Diagram – MAIN Board (3/4) – • See page 14 for Waveforms. • See page 23 for IC Block Diagram.

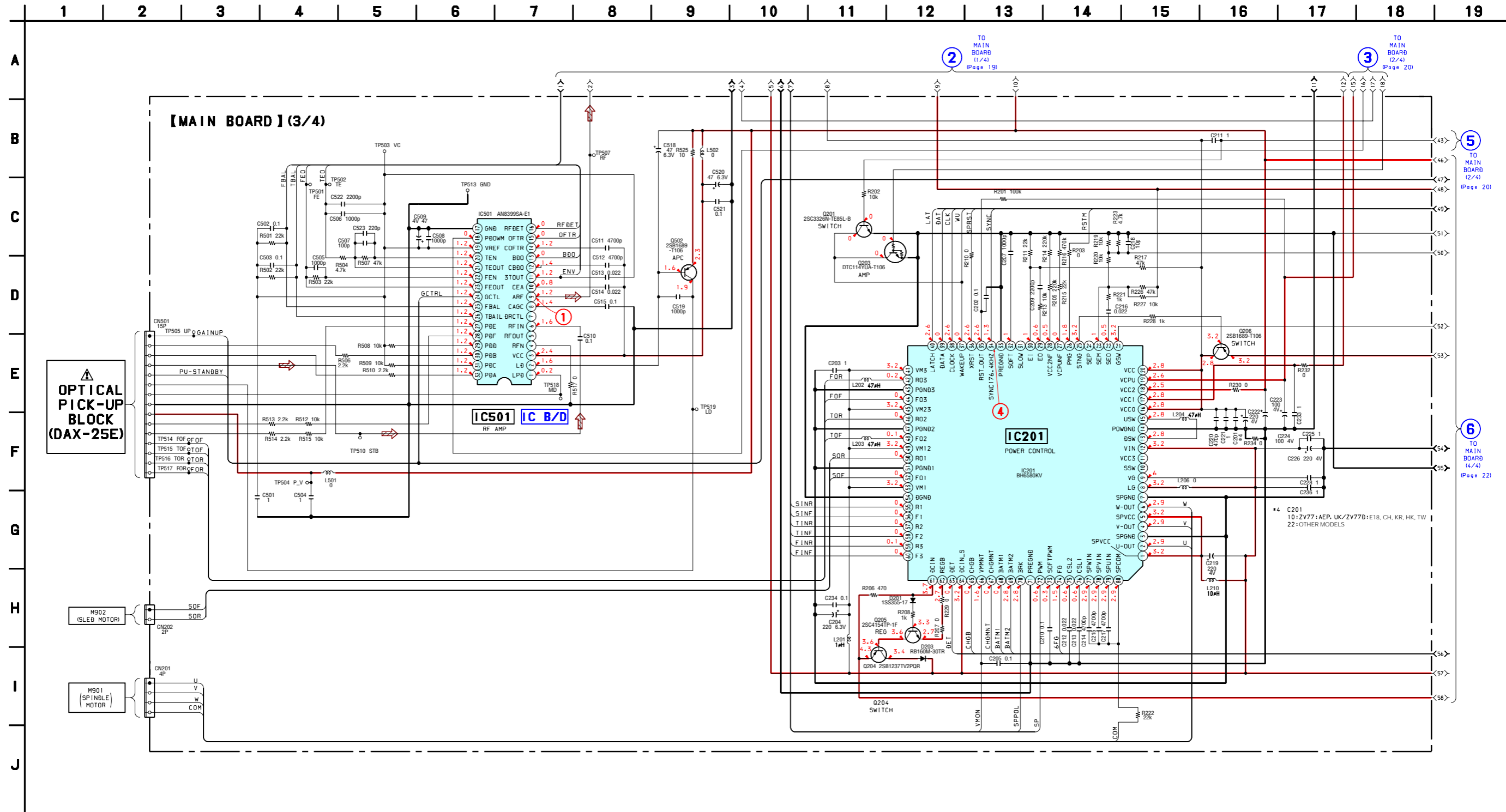

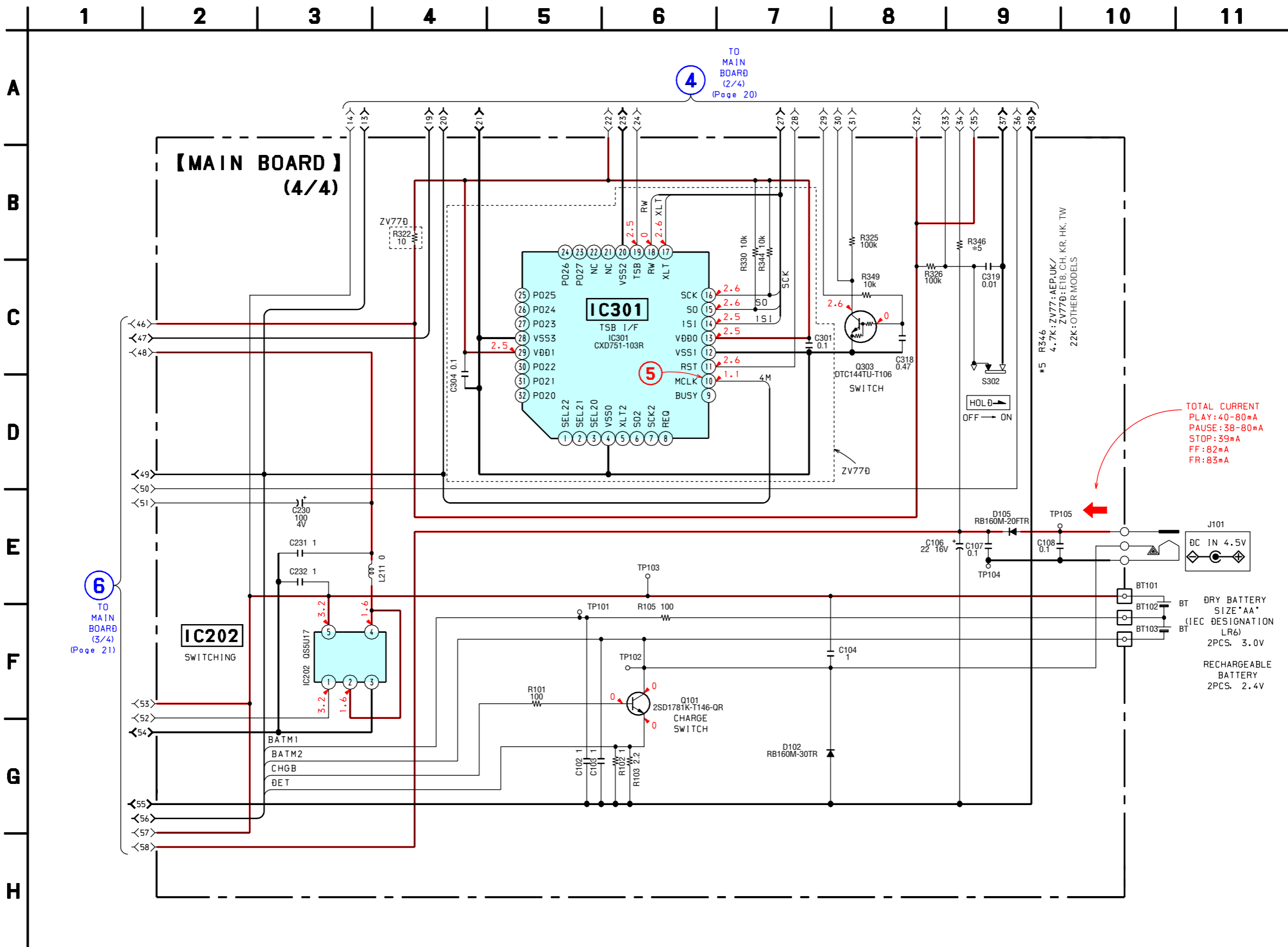

5-9. IC Block Diagrams

IC501 AN8399SA-E1

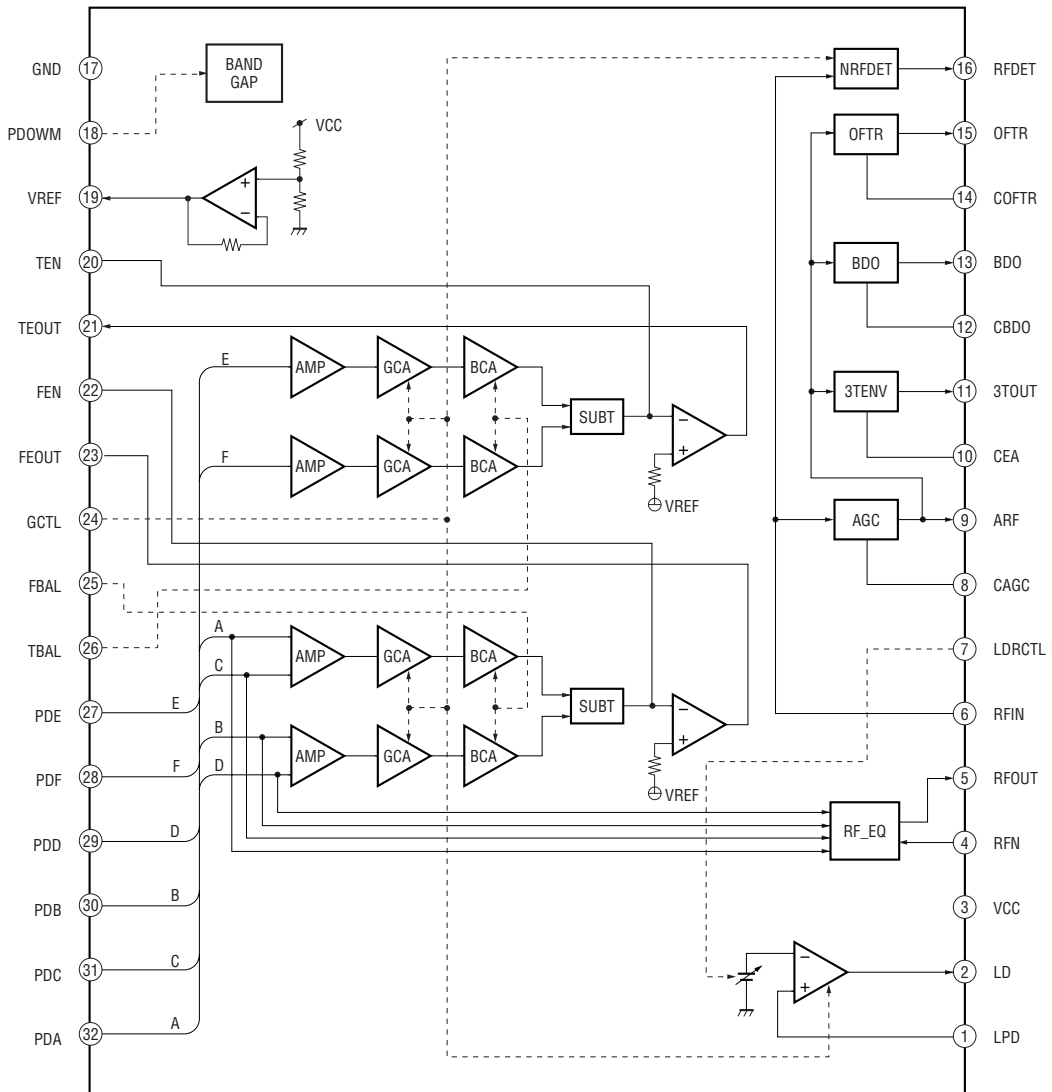

IC701 TA2120FN (EL)

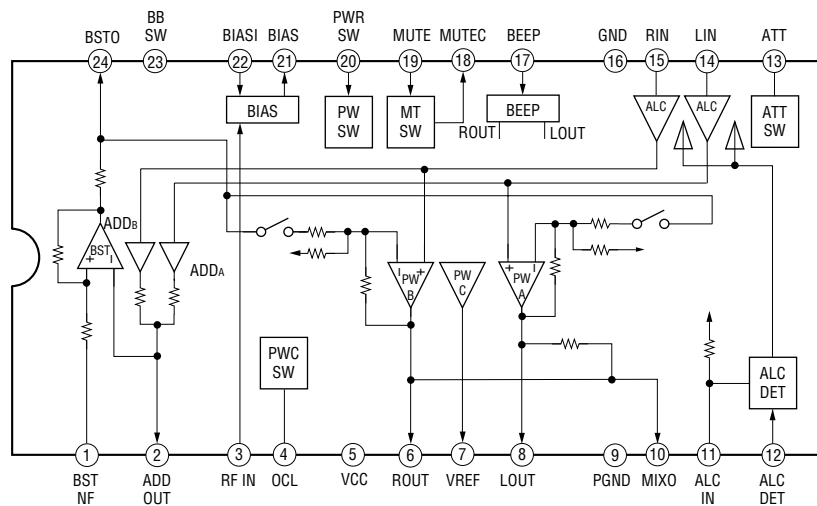

5-10. IC Pin Function Descriptions

• IC302 MN101C61G-PA3 (SYSTEM CONTROLLER)

Pin No.	Pin Name	I/O	Description
1	VREF-	—	Reference voltage terminal for A/D converter (connected to the ground)
2	CHRGIN	I	Charge voltage A/D input
3	FUNC1	I	Function key (S303, 304, 653, 654) signal input
4	VDIN	I	Battery voltage A/D input
5	ACIN	I	AC adaptor detection signal input (HIDCIN detection)
6	REM	I	Remote commander key A/D input
7	FUNC2	I	Function key (S651, 652, 657-659) signal input
8	NC	—	Not used (open)
9	VPP	—	Connected to VDD (supply 5V to VPP at writing the flash memory)
10	VREF+	—	Reference voltage terminal for A/D converter (connected to VDD)
11	VDD	—	Power supply terminal (microcomputer)
12	OSC2	O	Clock output (8.4672MHz)
13	OSC1	I	Clock input (8.4672MHz)
14	VSS	—	Ground terminal (microcomputer)
15	XI	—	Not used (connected to the ground)
16	XO	—	Not used (open)
17	MMOD	—	Not used (connected to the ground)
18	MDATA	O	MDATA output to the DSP (IC402)
19	STAT	I	STAT input from the DSP (IC402)
20	MCLK	O	MCLK output to the DSP (IC402)
21	SDO/L_SI	O	Data output to the liquid crystal display
22	P04	O	Not used (open)
23	BCLK/L_SCL	O	Clock output to the liquid crystal display
24	BEEP	O	Beep signal output
25	NRST	I	Microcomputer reset signal input "L" : reset
26	NDRST	O	Reset signal output to the DSP (IC402) "L" : reset
27	XEASS-ON	O	Equalizer selection signal output in case of MP3 "H" : on
28	SP	I	PWM signal input from the DSP (IC402)
29	SYNC	O	Clock (176.4kHz) output to the driver/power controller (IC201)
30	FG	I	FG pulse input from the driver/power controller (IC201)
31	BLKCK	I	BLKCK input from the DSP (IC402)
32	DQSY	I	DQSY input from the DSP (IC402)
33	PU-ON	O	Pick-up standby control signal output "H" : on
34	XREF-ON	O	Standby control signal output to the RF amplifier (IC501) "L" : on
35	WU	O	WAKEUP signal output to the driver/power controller (IC201) "L" : wakeup
36	MLD	O	MLD signal output to the DSP (IC402)
37	TXTD	I	CD text data input from the DSP (IC402)
38	TXTCK	O	Clock for CD text output to the DSP (IC402)
39	GCTRL	O	Gain control and LD auto power control signal output to the RF amplifier (IC501) "Hi-z" : LD on, "L" : off
40	GAINUP	O	RF amplifier gain control signal to the optical pick-up "H" : up
41	TX DET	I	TX connector detection signal input "H" : connector in Not used (fixed at "L")
42	RW	O	TSB RW signal output to the TSB interface (IC301)
43	XLT	O	TSB XLT signal output to the TSB interface (IC301)
44	ISO	O	Serial data output to the TSB interface (IC301)
45	SI	I	Serial data input to the TSB interface (IC301)
46	SCK	O	Serial clock output to the TSB interface (IC301)
47	VDET2	I	VDET2 signal input from the DSP (IC402)
48	RRST	O	Reset signal output to the TSB interface (IC301)
49	NC	O	Not used (open)
50	CS	O	Chip select signal output to the EEPROM Not used (open)

Pin No.	Pin Name	I/O	Description
51	SK	O	Serial clock output to the EEPROM Not used (open)
52	DI	O	Serial data output to the EEPROM Not used (open)
53	DO	I	Serial data input from the EEPROM Not used (open)
54	EXTBATT	I	External battery connection detection signal input "L" : external battery is set Not used (fixed at "H")
55	SWDO	I	TX output changeover signal input (fixed at "L")
56	DOOR2	I	Door (open to close) detection signal input "L" just after cancellation of reset : door open to close
57	SWR/H	I	Hold switch signal input "L" : hold switch on
58	DOOR	I	CD door switch detection signal input "L" : door close
59	2/7	I	CHP-2/DHP-7 detection input "L" : CHP-2 (open)
60	L_RS	O	Register selection signal output to the liquid crystal display
61	L_CS	O	Chip selection signal output to the liquid crystal display
62	L_RST	O	Reset signal output to the liquid crystal display
63	TEST	I	Test mode setting input terminal "L" : test mode
64, 65	NC	O	Not used (open)
66	K-PLAY	I	Play key on the set signal input "H" : play key on
67	K-STOP	I	Stop key on the set signal input "H" : stop key on
68	EEPROM	I	EEPROM discrimination signal input terminal Not used (open)
69	NC	I	Not used (open)
70	A-MUTE	O	Muting control signal output to the headphone amplifier (IC701) "H" : muting on
71	STANDBY	O	Standby control signal output to the headphone amplifier (IC701) "L" : standby
72	DSL2	O	Bass boost control 2 signal output "H" : DSL2 on
73	DSL1	O	Bass boost control 1 signal output "H" : DSL1 on
74	DA/MP3	O	DSP output voltage changeover signal output "L" : MP3, "Hi-z" : DA
75	SPRST	O	Reset signal output to the driver/power controller (IC201)
76	RMC-WU	O	Remote commander AD line changeover signal output "L" : on
77	LAT	O	Latch signal output to the driver/power controller (IC201)
78	CLK	O	Clock output to the driver/power controller (IC201)
79	DAT	O	Data output to the driver/power controller (IC201)
80	CHRGLED	O	Charge LED control signal output "L" : on Not used (open)

SECTION 6 EXPLODED VIEWS

NOTE:

- -XX, -X mean standardized parts, so they may have some differences from the original one.
- Items marked "*" are not stocked since they are seldom required for routine service. Some delay should be anticipated when ordering these items.
- Accessories and packing materials are given in the last of this parts list.
- The mechanical parts with no reference number in the exploded views are not supplied.

- Abbreviation
 AUS : Australian model
 CH : Chinese model
 E18 : 100-240V AC Area in E model
 E33 : 100-240V AC Area in E model
 (without VS)
 CND : Canadian model
 KR : Korean model
 HK : Hong Kong model
 TW : Taiwan model

The components identified by mark \triangle or dotted line with mark \triangle are critical for safety. Replace only with part number specified.

Les composants identifiés par une marque \triangle sont critiques pour la sécurité. Ne les remplacer que par une pièce portant le numéro spécifié.

6-1. Cabinet (upper) Section

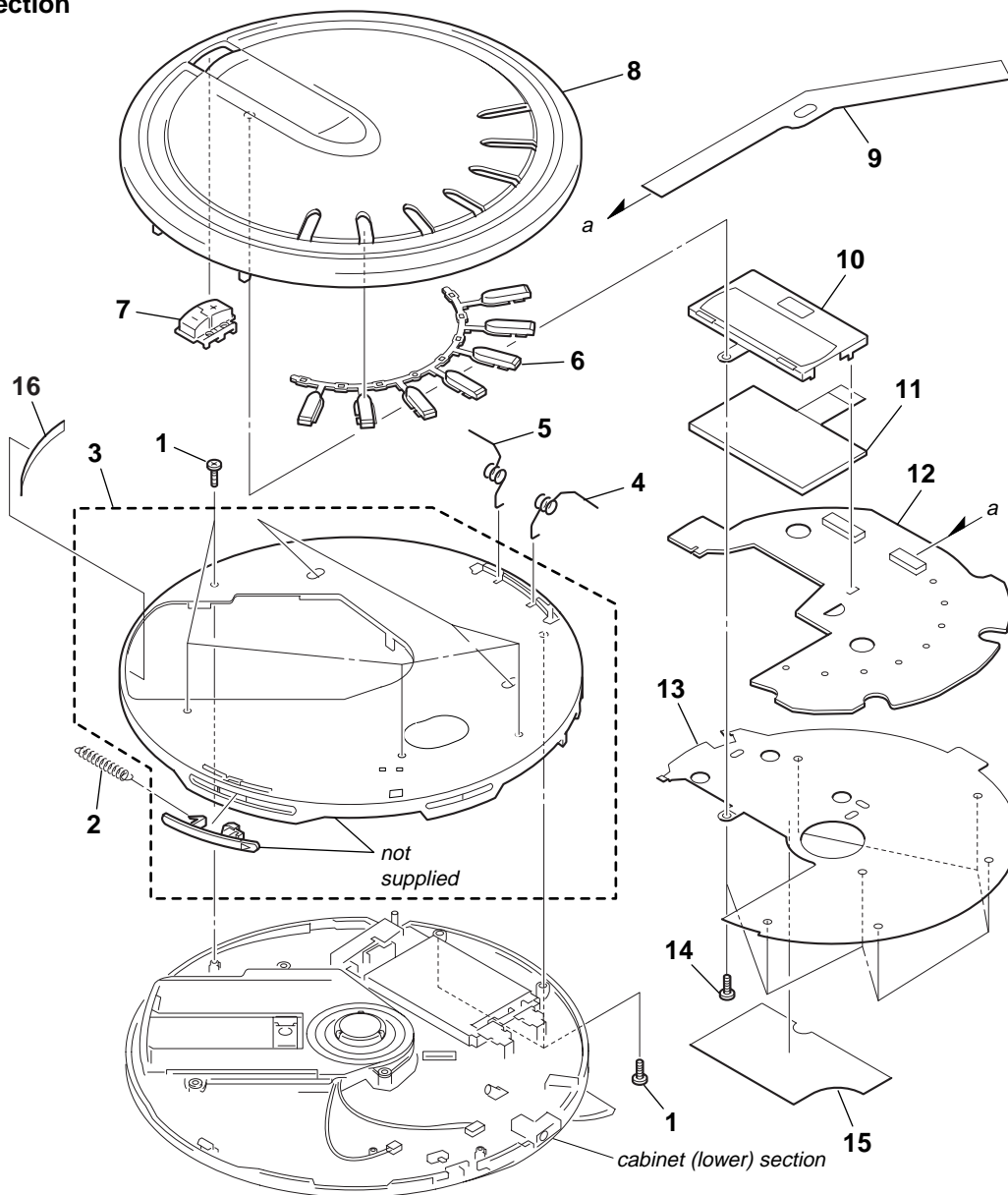

Ref. No.	Part No.	Description	Remarks	Ref. No.	Part No.	Description	Remarks
1	3-245-862-31	SCREW (B2), TAPPING		8	X-3383-426-1	LID SUB ASSY, UPPER (ZV77/ZV77D:E18,E33)	
2	3-249-069-01	SPRING, TENSION		8	X-3383-427-1	LID SUB ASSY, UPPER (ZV77D:AEP,CH,KR)	
3	X-3383-301-1	CABINET (FRONT) SUB ASSY (EXCEPT ZV77D:AEP,CH,KR)		8	X-3383-461-1	LID SUB ASSY, UPPER (ZV77C)	
3	X-3383-428-1	CABINET (FRONT) SUB ASSY (ZV77D:AEP,CH,KR)		9	1-688-839-11	PWB, FLEXIBLE	
4	3-249-954-01	SPRING, FULL OPEN RIGHT		10	3-249-956-01	CASE, LCD	
5	3-249-953-01	SPRING, FULL OPEN LEFT		11	1-805-178-11	DISPLAY PANEL, LIQUID CRYSTAL	
6	3-249-948-01	BUTTON, CONTROL MAIN		* 12	A-3683-496-A	LID BOARD COMPLETE	
7	3-249-951-01	BUTTON, CONTROL SUB		13	3-249-949-01	COVER, LID	
8	X-3383-302-1	LID SUB ASSY, UPPER (ZV71)		14	3-355-424-81	SCREW, TAPPING	
8	X-3383-377-1	LID SUB ASSY, UPPER (ZV71C)		15	3-255-466-01	SHEET (COVER, LID), ADH	
				16	3-254-597-01	CUSHON, CABI	

6-2. Cabinet (lower) Section

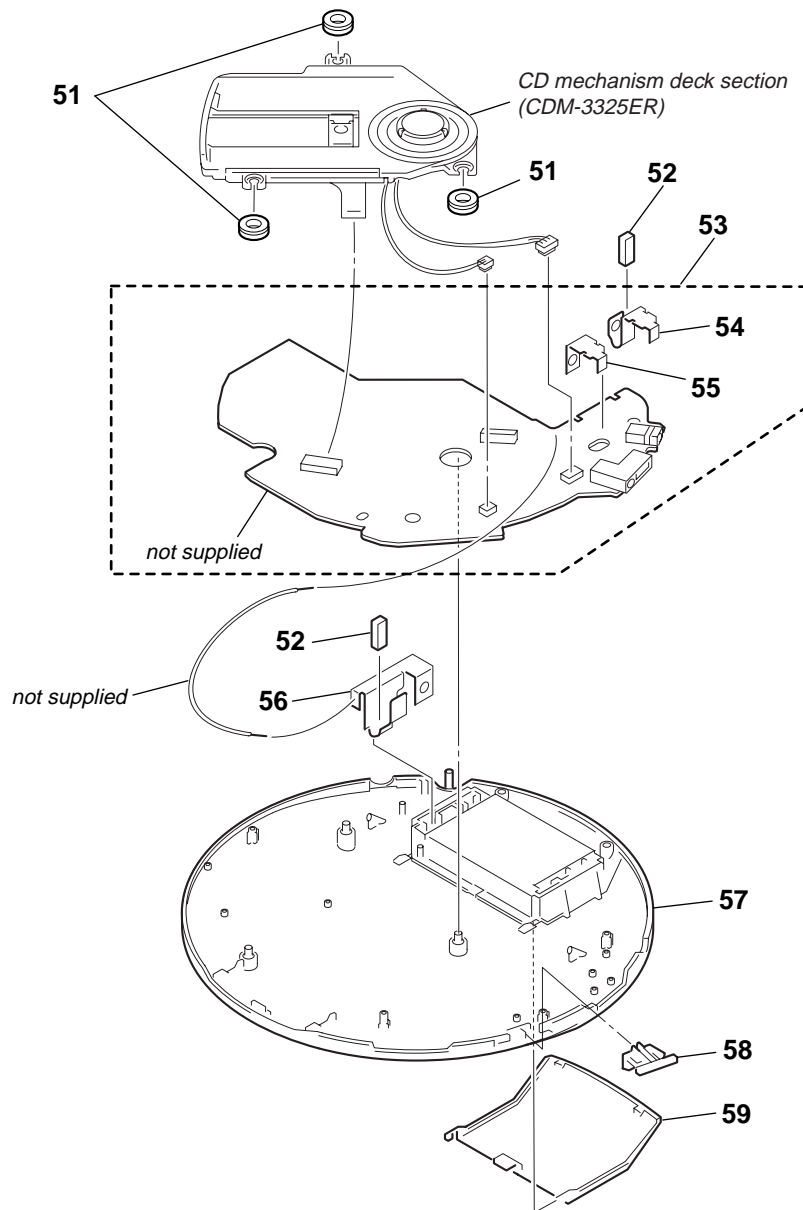

Ref. No.	Part No.	Description	Remarks	Ref. No.	Part No.	Description	Remarks
51	3-245-331-02	INSULATOR		54	3-249-065-01	TERMINAL BOARD (-), BATTERY	
52	3-254-581-01	CUSHON, CONTACT		55	3-249-064-01	TERMINAL BOARD (+), BATTERY	
* 53	A-3683-561-A	MAIN BOARD COMPLETE (ZV71/ZV71C/ZV77:CND, E18,E33,AUS/ZV77C)		56	3-249-066-01	TERMINAL BOARD (RELAY), BATTERY	
* 53	A-3683-662-A	MAIN BOARD COMPLETE (ZV77D:AEP)		57	3-249-054-31	CABINET, LOWER (EXCEPT ZV77D:AEP,CH,KR)	
* 53	A-3683-688-A	MAIN BOARD COMPLETE (ZV77:AEP,UK)		57	3-249-054-41	CABINET, LOWER (ZV77D:AEP,CH,KR)	
* 53	A-3683-692-A	MAIN BOARD COMPLETE (ZV77D:E18,CH,KR,HK,TW)		58	3-249-059-11	KNOB, HOLD	
				59	3-249-055-11	LID, BATTERY	

6-3. CD Mechanism Deck Section (CDM-3325ER)

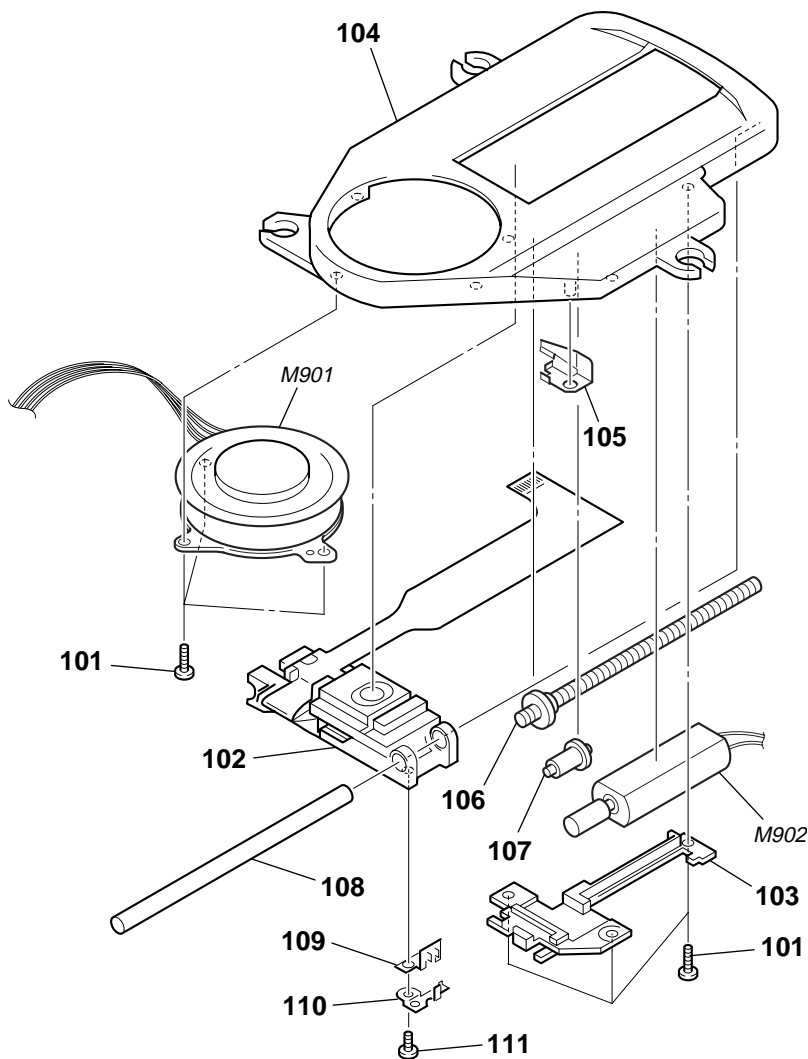

Ref. No.	Part No.	Description	Remarks	Ref. No.	Part No.	Description	Remarks
101	3-318-203-61	SCREW (B1.7X4), TAPPING		108	3-221-475-01	SHAFT, STANDARD	
△ 102	X-3380-950-1	OPTICAL PICK-UP (DAX-25E)		109	3-222-298-01	RACK	
103	3-221-473-01	COVER, GEAR		110	3-222-299-01	SPRING, RACK RETAINER	
104	3-221-472-02	CHASSIS		111	3-348-998-31	SCREW (M1.4X2.5), TAPPING, PAN	
105	3-221-474-01	SPRING, SLED		M901	A-3180-965-A	MOTOR ASSY, TURN TABLE (SPINDLE)	
106	A-3180-967-A	FEED ASSY, SCREW		M902	A-3180-966-A	MOTOR ASSY, SLED (SLED)	
107	3-221-268-01	GEAR (B)					

<p>The components identified by mark △ or dotted line with mark △ are critical for safety. Replace only with part number specified.</p>	<p>Les composants identifiés par une marque △ sont critiques pour la sécurité. Ne les remplacer que par une pièce portant le numéro spécifié.</p>
---	---

SECTION 7

ELECTRICAL PARTS LIST

LID MAIN

NOTE:

- Due to standardization, replacements in the parts list may be different from the parts specified in the diagrams or the components used on the set.
- -XX and -X mean standardized parts, so they may have some difference from the original one.
- RESISTORS
All resistors are in ohms.
METAL: Metal-film resistor.
METAL OXIDE: Metal oxide-film resistor.
F: nonflammable
- Items marked "*" are not stocked since they are seldom required for routine service. Some delay should be anticipated when ordering these items.

- SEMICONDUCTORS
In each case, u: μ , for example:
uA. . . : μ A. . . uPA. . . : μ PA. . .
uPB. . . : μ PB. . . uPC. . . : μ PC. . .
uPD. . . : μ PD. . .
- Abbreviation
AUS : Australian model
CH : Chinese model
E18 : 100-240V AC Area in E model
E33 : 100-240V AC Area in E model
(without VS)
CND: Canadian model
KR : Korean model
HK : Hong Kong model
TW : Taiwan model

- CAPACITORS
uF: μ F
• COILS
uH: μ H

When indicating parts by reference number, please include the board name.

The components identified by mark Δ or dotted line with mark Δ are critical for safety. Replace only with part number specified.

Les composants identifiés par une marque Δ sont critiques pour la sécurité. Ne les remplacer que par une pièce portant le numéro spécifié.

Ref. No.	Part No.	Description	Remarks	Ref. No.	Part No.	Description	Remarks
*	A-3683-496-A	LID BOARD, COMPLETE *****		S655	1-771-138-21	SWITCH, KEY BOARD (■)	
		< CAPACITOR >		S656	1-771-138-21	SWITCH, KEY BOARD (▶▶)	
C601	1-115-156-11	CERAMIC CHIP 1uF	10V	S657	1-771-138-21	SWITCH, KEY BOARD (DISPLAY)	
C602	1-113-619-11	CERAMIC CHIP 0.47uF	10V	S658	1-771-138-21	SWITCH, KEY BOARD (SOUND)	
C603	1-113-619-11	CERAMIC CHIP 0.47uF	10V	S659	1-771-138-21	SWITCH, KEY BOARD (↩)	
C604	1-113-619-11	CERAMIC CHIP 0.47uF	10V	*****			
C605	1-113-619-11	CERAMIC CHIP 0.47uF	10V	*	A-3683-561-A	MAIN BOARD, COMPLETE (ZV71/ZV71C/ZV77:CND,E18,E33,AUS/ZV77C) *****	
C607	1-113-619-11	CERAMIC CHIP 0.47uF	10V	*	A-3683-662-A	MAIN BOARD, COMPLETE (ZV77D:AEP) *****	
C608	1-113-619-11	CERAMIC CHIP 0.47uF	10V	*	A-3683-688-A	MAIN BOARD, COMPLETE (ZV77:AEP,UK) *****	
C611	1-115-156-11	CERAMIC CHIP 1uF	10V	*	A-3683-692-A	MAIN BOARD, COMPLETE (ZV77D:E18,CH,KR,HK,TW) *****	
C612	1-162-915-11	CERAMIC CHIP 10PF	0.5PF 50V				
C614	1-113-619-11	CERAMIC CHIP 0.47uF	10V				
		< CONNECTOR >					
CN601	1-816-276-21	CONNECTOR, FPC (ZIF) 18P					
CN651	1-817-459-11	CONNECTOR, FFC/FPC (ZIF)					
		< RESISTOR >		3-249-064-01		TERMINAL BOARD (+), BATTERY	
R601	1-216-295-91	SHORT CHIP 0		3-249-065-01		TERMINAL BOARD (-), BATTERY	
R602	1-216-837-11	METAL CHIP 22K	5% 1/16W			< CAPACITOR >	
R603	1-216-833-11	METAL CHIP 10K	5% 1/16W	C102	1-115-156-11	CERAMIC CHIP 1uF	10V
R604	1-216-845-11	METAL CHIP 100K	5% 1/16W	C103	1-115-156-11	CERAMIC CHIP 1uF	10V
R605	1-216-837-11	METAL CHIP 22K	5% 1/16W	C104	1-115-156-11	CERAMIC CHIP 1uF	10V
R606	1-216-845-11	METAL CHIP 100K	5% 1/16W	C106	1-126-395-11	ELECT 22uF	20% 16V
R607	1-216-833-11	METAL CHIP 10K	5% 1/16W	C107	1-107-826-11	CERAMIC CHIP 0.1uF	10.00% 16V
R608	1-216-837-11	METAL CHIP 22K	5% 1/16W	C108	1-107-826-11	CERAMIC CHIP 0.1uF	10.00% 16V
R609	1-216-837-11	METAL CHIP 22K	5% 1/16W	C201	1-165-897-11	TANTAL. CHIP 22uF	20% 10V
R610	1-216-845-11	METAL CHIP 100K	5% 1/16W			(EXCEPT ZV77:AEP,UK/ZV77D:E18,CH,KR,HK,TW)	
R611	1-216-841-11	METAL CHIP 47K	5% 1/16W	C201	1-127-692-11	CERAMIC CHIP 10uF	10.00% 6.3V
R612	1-216-809-11	METAL CHIP 100	5% 1/16W			(ZV77:AEP,UK/ZV77D:E18,CH,KR,HK,TW)	
R613	1-216-809-11	METAL CHIP 100	5% 1/16W	C202	1-107-826-11	CERAMIC CHIP 0.1uF	10.00% 16V
R614	1-216-809-11	METAL CHIP 100	5% 1/16W	C203	1-115-156-11	CERAMIC CHIP 1uF	10V
R615	1-216-809-11	METAL CHIP 100	5% 1/16W	C204	1-128-829-91	TANTAL. CHIP 220uF	20% 6.3V
R616	1-216-797-11	METAL CHIP 10	5% 1/16W	C205	1-164-156-11	CERAMIC CHIP 0.1uF	25V
R617	1-216-295-91	SHORT CHIP 0		C207	1-162-964-11	CERAMIC CHIP 0.001uF	10% 50V
R618	1-216-295-91	SHORT CHIP 0		C209	1-162-966-11	CERAMIC CHIP 0.0022uF	10% 50V
R619	1-216-295-91	SHORT CHIP 0		C210	1-107-826-11	CERAMIC CHIP 0.1uF	10.00% 16V
		< SWITCH >		C211	1-125-837-91	CERAMIC CHIP 1uF	10% 6.3V
S651	1-771-138-21	SWITCH, KEY BOARD (-)		C212	1-164-227-11	CERAMIC CHIP 0.022uF	10% 25V
S652	1-771-138-21	SWITCH, KEY BOARD (+)		C213	1-164-227-11	CERAMIC CHIP 0.022uF	10% 25V
S653	1-771-138-21	SWITCH, KEY BOARD (◀◀)		C214	1-162-968-11	CERAMIC CHIP 0.0047uF	10% 50V
S654	1-771-138-21	SWITCH, KEY BOARD (▶▶)		C215	1-162-968-11	CERAMIC CHIP 0.0047uF	10% 50V

XP-ZV71/ZV71C/ZV77/ZV77C/ZV77D

Ver 1.1 2003.06

MAIN

Ref. No.	Part No.	Description	Remarks	Ref. No.	Part No.	Description	Remarks
C216	1-164-227-11	CERAMIC CHIP	0.022uF 10% 25V	C501	1-115-156-11	CERAMIC CHIP	1uF 10V
C217	1-162-968-11	CERAMIC CHIP	0.0047uF 10% 50V	C502	1-164-156-11	CERAMIC CHIP	0.1uF 25V
C218	1-162-915-11	CERAMIC CHIP	10PF 0.5PF 50V	C503	1-164-156-11	CERAMIC CHIP	0.1uF 25V
C219	1-124-434-00	ELECT	220uF 20.00% 4V	C504	1-125-837-91	CERAMIC CHIP	1uF 10% 6.3V
C220	1-164-315-11	CERAMIC CHIP	470PF 5.00% 50V	C505	1-162-964-11	CERAMIC CHIP	0.001uF 10% 50V
C221	1-125-837-91	CERAMIC CHIP	1uF 10% 6.3V	C506	1-162-964-11	CERAMIC CHIP	0.001uF 10% 50V
C222	1-124-434-00	ELECT	220uF 20.00% 4V	C507	1-162-927-11	CERAMIC CHIP	100PF 5% 50V
C223	1-126-209-11	ELECT CHIP	100uF 20.00% 4V	C508	1-162-964-11	CERAMIC CHIP	0.001uF 10% 50V
C224	1-126-209-11	ELECT CHIP	100uF 20.00% 4V	C509	1-131-862-91	TANTAL. CHIP	47uF 20% 4V
C225	1-125-837-91	CERAMIC CHIP	1uF 10% 6.3V	C510	1-107-826-11	CERAMIC CHIP	0.1uF 10.00% 16V
C226	1-124-434-00	ELECT	220uF 20.00% 4V	C511	1-162-968-11	CERAMIC CHIP	0.0047uF 10% 50V
C228	1-125-837-91	CERAMIC CHIP	1uF 10% 6.3V	C512	1-162-968-11	CERAMIC CHIP	0.0047uF 10% 50V
C230	1-126-209-11	ELECT CHIP	100uF 20.00% 4V	C513	1-164-227-11	CERAMIC CHIP	0.022uF 10% 25V
C231	1-125-837-91	CERAMIC CHIP	1uF 10% 6.3V	C514	1-164-227-11	CERAMIC CHIP	0.022uF 10% 25V
C232	1-115-156-11	CERAMIC CHIP	1uF 10V	C515	1-107-826-11	CERAMIC CHIP	0.1uF 10.00% 16V
C233	1-125-837-91	CERAMIC CHIP	1uF 10% 6.3V	C518	1-100-539-91	TANTAL. CHIP	47uF 20% 6.3V
C234	1-107-826-11	CERAMIC CHIP	0.1uF 10.00% 16V	C519	1-162-964-11	CERAMIC CHIP	0.001uF 10% 50V
C236	1-125-837-91	CERAMIC CHIP	1uF 10% 6.3V	C520	1-100-539-91	TANTAL. CHIP	47uF 20% 6.3V
C301	1-164-156-11	CERAMIC CHIP	0.1uF 25V	C521	1-107-826-11	CERAMIC CHIP	0.1uF 10.00% 16V
C302	1-162-964-11	CERAMIC CHIP	0.001uF 10% 50V	C522	1-162-966-11	CERAMIC CHIP	0.0022uF 10% 50V
C303	1-107-826-11	CERAMIC CHIP	0.1uF 10.00% 16V	C523	1-164-230-11	CERAMIC CHIP	220PF 5.00% 50V
C304	1-164-156-11	CERAMIC CHIP	0.1uF 25V	C703	1-162-915-11	CERAMIC CHIP	10PF 0.5PF 50V
C305	1-107-826-11	CERAMIC CHIP	0.1uF 10.00% 16V	C704	1-162-915-11	CERAMIC CHIP	10PF 0.5PF 50V
C306	1-162-964-11	CERAMIC CHIP	0.001uF 10% 50V	C706	1-107-826-11	CERAMIC CHIP	0.1uF 10.00% 16V
C307	1-115-156-11	CERAMIC CHIP	1uF 10V	C707	1-107-826-11	CERAMIC CHIP	0.1uF 10.00% 16V
C308	1-162-964-11	CERAMIC CHIP	0.001uF 10% 50V	C708	1-107-826-11	CERAMIC CHIP	0.1uF 10.00% 16V
C309	1-162-964-11	CERAMIC CHIP	0.001uF 10% 50V	C709	1-107-826-11	CERAMIC CHIP	0.1uF 10.00% 16V
C310	1-162-964-11	CERAMIC CHIP	0.001uF 10% 50V	C710	1-125-838-11	CERAMIC CHIP	2.2uF 10% 6.3V
C311	1-162-970-11	CERAMIC CHIP	0.01uF 10% 25V	C711	1-126-209-11	ELECT CHIP	100uF 20.00% 4V
C312	1-162-964-11	CERAMIC CHIP	0.001uF 10% 50V	C712	1-107-826-11	CERAMIC CHIP	0.1uF 10.00% 16V
C313	1-162-970-11	CERAMIC CHIP	0.01uF 10% 25V	C713	1-104-847-11	TANTAL. CHIP	22uF 20.00% 4V
C314	1-107-826-11	CERAMIC CHIP	0.1uF 10.00% 16V	C714	1-125-837-91	CERAMIC CHIP	1uF 10% 6.3V
C315	1-162-964-11	CERAMIC CHIP	0.001uF 10% 50V	C715	1-164-156-11	CERAMIC CHIP	0.1uF 25V
C316	1-162-964-11	CERAMIC CHIP	0.001uF 10% 50V	C716	1-104-847-11	TANTAL. CHIP	22uF 20.00% 4V
C318	1-117-863-11	CERAMIC CHIP	0.47uF 10.00% 6.3V	C717	1-162-962-11	CERAMIC CHIP	470PF 10% 50V
C319	1-162-970-11	CERAMIC CHIP	0.01uF 10% 25V	C718	1-162-962-11	CERAMIC CHIP	470PF 10% 50V
C320	1-125-837-91	CERAMIC CHIP	1uF 10% 6.3V	C719	1-125-837-91	CERAMIC CHIP	1uF 10% 6.3V
C321	1-164-156-11	CERAMIC CHIP	0.1uF 25V	C720	1-162-970-11	CERAMIC CHIP	0.01uF 10% 25V
C401	1-162-964-11	CERAMIC CHIP	0.001uF 10% 50V	C721	1-125-837-91	CERAMIC CHIP	1uF 10% 6.3V
C403	1-164-230-11	CERAMIC CHIP	220PF 5.00% 50V	C722	1-162-970-11	CERAMIC CHIP	0.01uF 10% 25V
C404	1-107-826-11	CERAMIC CHIP	0.1uF 10.00% 16V	C723	1-131-862-91	TANTAL. CHIP	47uF 20% 4V
C405	1-164-156-11	CERAMIC CHIP	0.1uF 25V	C724	1-164-156-11	CERAMIC CHIP	0.1uF 25V
C406	1-119-750-11	TANTAL. CHIP	22uF 20.00% 6.3V	C725	1-124-434-00	ELECT	220uF 20.00% 4V
C407	1-125-837-91	CERAMIC CHIP	1uF 10% 6.3V	C726	1-124-434-00	ELECT	220uF 20.00% 4V
C408	1-107-826-11	CERAMIC CHIP	0.1uF 10.00% 16V	C727	1-135-259-11	TANTAL. CHIP	10uF 20.00% 6.3V
C409	1-107-826-11	CERAMIC CHIP	0.1uF 10.00% 16V	C728	1-115-467-11	CERAMIC CHIP	0.22uF 10.00% 10V
C410	1-162-923-11	CERAMIC CHIP	47PF 5% 50V			< CONNECTOR >	
C411	1-164-315-11	CERAMIC CHIP	470PF 5.00% 50V	* CN201	1-785-877-21	HOUSING, CONNECTOR 4P	
C412	1-162-964-11	CERAMIC CHIP	0.001uF 10% 50V	CN202	1-784-342-21	HOUSING, CONNECTOR 2P	
C413	1-164-156-11	CERAMIC CHIP	0.1uF 25V	CN301	1-779-331-11	CONNECTOR, FFC/FPC 14P	
C414	1-164-227-11	CERAMIC CHIP	0.022uF 10% 25V	CN501	1-573-355-11	CONNECTOR, FFC/FPC (ZIF) 15P	
C415	1-162-964-11	CERAMIC CHIP	0.001uF 10% 50V			< DIODE >	
C416	1-164-156-11	CERAMIC CHIP	0.1uF 25V	D102	8-719-081-34	DIODE RB160M-30TR	
C417	1-164-227-11	CERAMIC CHIP	0.022uF 10% 25V	D105	6-500-220-11	DIODE RB161M-20FTR	
C418	1-107-826-11	CERAMIC CHIP	0.1uF 10.00% 16V	D201	8-719-988-61	DIODE 1SS355TE-17	
C419	1-107-826-11	CERAMIC CHIP	0.1uF 10.00% 16V	D203	8-719-081-34	DIODE RB160M-30TR	
C420	1-115-156-11	CERAMIC CHIP	1uF 10V	D301	8-719-071-34	DIODE RB521S-30-TE61	
C421	1-100-539-91	TANTAL. CHIP	47uF 20% 6.3V	D302	8-719-989-03	DIODE DAN222-TL	
C422	1-119-750-11	TANTAL. CHIP	22uF 20.00% 6.3V				

Ref. No.	Part No.	Description	Remarks	Ref. No.	Part No.	Description	Remarks
< FERRITE BEAD >				< RESISTOR >			
FB701	1-216-864-11	METAL CHIP	0 5% 1/16W (ZV77D)	R101	1-216-809-11	METAL CHIP	100 5% 1/16W
FB702	1-216-298-00	METAL CHIP	2.2 5% 1/10W (ZV77D:AEP)	R102	1-217-671-11	METAL CHIP	1 5% 1/10W
FB702	1-400-145-21	INDUCTOR	47uH (ZV77D:E18,CH,KR,HK,TW)	R103	1-216-298-00	METAL CHIP	2.2 5% 1/10W
FB703	1-500-234-22	FERRITE	0uH	R105	1-216-809-11	METAL CHIP	100 5% 1/16W
FB704	1-500-234-22	FERRITE	0uH	R201	1-216-845-11	METAL CHIP	100K 5% 1/16W
FB705	1-500-234-22	FERRITE	0uH	R202	1-216-833-11	METAL CHIP	10K 5% 1/16W
FB706	1-216-864-11	METAL CHIP	0 5% 1/16W (ZV77D)	R203	1-216-864-11	METAL CHIP	0 5% 1/16W
< IC >				R205	1-216-849-11	METAL CHIP	220K 5% 1/16W
IC201	6-703-034-01	IC BH6580KV		R206	1-216-817-11	METAL CHIP	470 5% 1/16W
IC202	6-550-573-01	TRANSISTOR QS5U17		R207	1-216-864-11	METAL CHIP	0 5% 1/16W
IC301	8-752-397-55	IC CXD751-103R (ZV77D)		R208	1-216-821-11	METAL CHIP	1K 5% 1/16W
IC302	6-802-688-04	IC MN101C61G-PA3		R210	1-216-864-11	METAL CHIP	0 5% 1/16W
IC304	6-703-959-01	IC PST3617UL		R211	1-218-879-11	METAL CHIP	22K 0.5% 1/10W
IC401	6-700-195-01	IC MSM51V17400F-10TK-FS		R213	1-216-833-11	METAL CHIP	10K 5% 1/16W
IC402	6-703-713-01	IC MN662791AB		R214	1-216-849-11	METAL CHIP	220K 5% 1/16W
IC501	6-703-626-01	IC AN8399SA-E1		R215	1-218-879-11	METAL CHIP	22K 0.5% 1/10W
IC701	8-759-681-65	IC TA2120FN(EL)		R216	1-218-911-11	METAL CHIP	470K 0.5% 1/10W
< JACK >				R217	1-218-887-11	METAL CHIP	47K 0.5% 1/10W
J101	1-778-153-51	JACK,DC(POLARITY UNIFIED TYPE)	(DC IN 4.5V)	R219	1-218-871-11	METAL CHIP	10K 0.5% 1/10W
J701	1-793-288-23	JACK (♁) (ZV77D)		R220	1-218-871-11	METAL CHIP	10K 0.5% 1/10W
J702	1-815-135-42	JACK, HEADPHONE (♁) (EXCEPT ZV77D)		R221	1-216-821-11	METAL CHIP	1K 5% 1/16W
< COIL >				R222	1-216-837-11	METAL CHIP	22K 5% 1/16W
L201	1-469-966-21	INDUCTOR	1uH	R223	1-216-829-11	METAL CHIP	4.7K 5% 1/16W
L202	1-400-145-21	INDUCTOR	47uH	R226	1-216-841-11	METAL CHIP	47K 5% 1/16W
L203	1-400-145-21	INDUCTOR	47uH	R227	1-218-871-11	METAL CHIP	10K 0.5% 1/10W
L204	1-419-368-21	INDUCTOR	47uH	R228	1-216-821-11	METAL CHIP	1K 5% 1/16W
L206	1-400-416-21	INDUCTOR	0uH	R229	1-216-864-11	METAL CHIP	0 5% 1/16W
L210	1-469-967-21	INDUCTOR	10uH	R230	1-216-864-11	METAL CHIP	0 5% 1/16W
L211	1-400-416-21	INDUCTOR	0uH	R232	1-216-864-11	METAL CHIP	0 5% 1/16W
L401	1-400-417-21	INDUCTOR	0uH	R234	1-216-295-91	SHORT CHIP	0
L402	1-400-416-21	INDUCTOR	0uH	R301	1-218-911-11	METAL CHIP	470K 0.5% 1/10W
L501	1-400-416-21	INDUCTOR	0uH	R302	1-218-903-11	METAL CHIP	220K 0.5% 1/10W
L502	1-400-416-21	INDUCTOR	0uH	R303	1-218-895-11	METAL CHIP	100K 0.5% 1/10W
< TRANSISTOR >				R304	1-218-911-11	METAL CHIP	470K 0.5% 1/10W
Q101	8-729-921-73	TRANSISTOR	2SD1781K-T146-QR	R305	1-216-833-11	METAL CHIP	10K 5% 1/16W (EXCEPT ZV77D)
Q201	8-729-202-38	TRANSISTOR	2SC3326N-TE85L-B	R305	1-218-871-11	METAL CHIP	10K 0.5% 1/10W (ZV77D)
Q203	8-729-028-99	TRANSISTOR	DTC114YUA-T106	R306	1-216-821-11	METAL CHIP	1K 5% 1/16W
Q204	6-550-070-01	TRANSISTOR	2SB1237TV2PQR	R307	1-218-863-11	METAL CHIP	4.7K 0.5% 1/10W
Q205	8-729-602-21	TRANSISTOR	2SC4154TP-1F	R308	1-216-837-11	METAL CHIP	22K 5% 1/16W
Q206	6-550-044-01	TRANSISTOR	2SB1689-T106	R309	1-216-857-11	METAL CHIP	1M 5% 1/16W
Q301	8-729-028-74	TRANSISTOR	DTA114TUA-T106 (ZV77D)	R310	1-216-857-11	METAL CHIP	1M 5% 1/16W
Q302	8-729-202-38	TRANSISTOR	2SC3326N-TE85L-B	R311	1-216-857-11	METAL CHIP	1M 5% 1/16W (ZV77D)
Q303	8-729-029-15	TRANSISTOR	DTC144TU-T106	R313	1-216-845-11	METAL CHIP	100K 5% 1/16W
Q401	8-729-028-99	TRANSISTOR	DTC114YUA-T106	R315	1-218-847-11	METAL CHIP	1K 0.5% 1/10W
Q502	6-550-044-01	TRANSISTOR	2SB1689-T106	R316	1-216-845-11	METAL CHIP	100K 5% 1/16W (EXCEPT ZV77:AEP,UK/ZV77D:E18,CH,KR,HK,TW)
Q701	8-729-028-99	TRANSISTOR	DTC114YUA-T106	R316	1-216-821-11	METAL CHIP	1K 5% 1/16W (ZV77:AEP,UK/ZV77D:E18,CH,KR,HK,TW)
				R317	1-216-841-11	METAL CHIP	47K 5% 1/16W
				R319	1-218-855-11	METAL CHIP	2.2K 0.5% 1/10W
				R320	1-216-845-11	METAL CHIP	100K 5% 1/16W
				R321	1-216-845-11	METAL CHIP	100K 5% 1/16W

MAIN

Ref. No.	Part No.	Description	Quantity	Percentage	Remarks
R322	1-216-797-11	METAL CHIP	10	5%	1/16W (ZV77D)
R323	1-216-845-11	METAL CHIP	100K	5%	1/16W
R325	1-216-845-11	METAL CHIP	100K	5%	1/16W
R326	1-216-845-11	METAL CHIP	100K	5%	1/16W
R327	1-216-809-11	METAL CHIP	100	5%	1/16W
R328	1-216-833-11	METAL CHIP	10K	5%	1/16W
R329	1-216-837-11	METAL CHIP	22K	5%	1/16W
R330	1-216-833-11	METAL CHIP	10K	5%	1/16W (ZV77D)
R331	1-216-821-11	METAL CHIP	1K	5%	1/16W
R332	1-216-821-11	METAL CHIP	1K	5%	1/16W
R333	1-216-841-11	METAL CHIP	47K	5%	1/16W
R334	1-216-853-11	METAL CHIP	470K	5%	1/16W
R335	1-216-841-11	METAL CHIP	47K	5%	1/16W
R336	1-216-841-11	METAL CHIP	47K	5%	1/16W
R337	1-218-895-11	METAL CHIP	100K	0.5%	1/10W
R338	1-216-857-11	METAL CHIP	1M	5%	1/16W
R340	1-216-845-11	METAL CHIP	100K	5%	1/16W
R342	1-216-853-11	METAL CHIP	470K	5%	1/16W
R343	1-216-809-11	METAL CHIP	100	5%	1/16W
R344	1-216-833-11	METAL CHIP	10K	5%	1/16W (ZV77D)
R346	1-216-837-11	METAL CHIP	22K	5%	1/16W (EXCEPT ZV77:AEP,UK/ZV77D:E18,CH,KR,HK,TW)
R346	1-216-829-11	METAL CHIP	4.7K	5%	1/16W (ZV77:AEP,UK/ZV77D:E18,CH,KR,HK,TW)
R347	1-216-853-11	METAL CHIP	470K	5%	1/16W (EXCEPT ZV77D)
R348	1-216-864-11	METAL CHIP	0	5%	1/16W (ZV77D)
R349	1-216-833-11	METAL CHIP	10K	5%	1/16W
R401	1-216-797-11	METAL CHIP	10	5%	1/16W
R402	1-216-841-11	METAL CHIP	47K	5%	1/16W
R403	1-218-446-11	METAL CHIP	1	5%	1/10W
R406	1-216-857-11	METAL CHIP	1M	5%	1/16W
R407	1-216-833-11	METAL CHIP	10K	5%	1/16W
R408	1-216-809-11	METAL CHIP	100	5%	1/16W
R409	1-216-864-11	METAL CHIP	0	5%	1/16W
R410	1-216-864-11	METAL CHIP	0	5%	1/16W
R411	1-216-864-11	METAL CHIP	0	5%	1/16W
R412	1-216-841-11	METAL CHIP	47K	5%	1/16W
R413	1-216-841-11	METAL CHIP	47K	5%	1/16W
R414	1-216-833-11	METAL CHIP	10K	5%	1/16W
R415	1-216-817-11	METAL CHIP	470	5%	1/16W
R416	1-216-805-11	METAL CHIP	47	5%	1/16W
R417	1-216-837-11	METAL CHIP	22K	5%	1/16W
R418	1-216-809-11	METAL CHIP	100	5%	1/16W
R501	1-216-837-11	METAL CHIP	22K	5%	1/16W
R502	1-216-837-11	METAL CHIP	22K	5%	1/16W
R503	1-216-837-11	METAL CHIP	22K	5%	1/16W
R504	1-216-829-11	METAL CHIP	4.7K	5%	1/16W
R506	1-216-825-11	METAL CHIP	2.2K	5%	1/16W
R507	1-216-841-11	METAL CHIP	47K	5%	1/16W
R508	1-216-833-11	METAL CHIP	10K	5%	1/16W
R509	1-216-833-11	METAL CHIP	10K	5%	1/16W
R510	1-216-825-11	METAL CHIP	2.2K	5%	1/16W
R512	1-218-871-11	METAL CHIP	10K	0.5%	1/10W
R513	1-216-825-11	METAL CHIP	2.2K	5%	1/16W
R514	1-216-825-11	METAL CHIP	2.2K	5%	1/16W
R515	1-218-871-11	METAL CHIP	10K	0.5%	1/10W
R517	1-216-864-11	METAL CHIP	0	5%	1/16W

Ref. No.	Part No.	Description	Quantity	Percentage	Remarks
R525	1-216-797-11	METAL CHIP	10	5%	1/16W
R701	1-216-837-11	METAL CHIP	22K	5%	1/16W
R702	1-216-809-11	METAL CHIP	100	5%	1/16W (ZV77D)
R703	1-216-789-11	METAL CHIP	2.2	5%	1/16W (ZV71/ZV71C/ZV77:CND,E18,E33,AUS/ZV77C)
R703	1-216-864-11	METAL CHIP	0	5%	1/16W (ZV77D:E18,CH,KR,HK,TW)
R703	1-216-793-11	METAL CHIP	4.7	5%	1/10W (ZV77:AEP,UK/ZV77D:AEP)
R704	1-216-789-11	METAL CHIP	2.2	5%	1/16W (ZV71/ZV71C/ZV77:CND,E18,E33,AUS/ZV77C)
R704	1-216-864-11	METAL CHIP	0	5%	1/16W (ZV77D:E18,CH,KR,HK,TW)
R704	1-216-793-11	METAL CHIP	4.7	5%	1/10W (ZV77:AEP,UK/ZV77D:AEP)
R705	1-216-833-11	METAL CHIP	10K	5%	1/16W
R706	1-216-833-11	METAL CHIP	10K	5%	1/16W
R707	1-216-793-11	METAL CHIP	4.7	5%	1/10W
R708	1-216-793-11	METAL CHIP	4.7	5%	1/10W
R709	1-216-829-11	METAL CHIP	4.7K	5%	1/16W
R710	1-216-821-11	METAL CHIP	1K	5%	1/16W
R711	1-216-793-11	METAL CHIP	4.7	5%	1/10W
R713	1-216-833-11	METAL CHIP	10K	5%	1/16W
R714	1-216-833-11	METAL CHIP	10K	5%	1/16W
R715	1-216-833-11	METAL CHIP	10K	5%	1/16W
R716	1-216-833-11	METAL CHIP	10K	5%	1/16W
R717	1-216-841-11	METAL CHIP	47K	5%	1/16W
R718	1-216-841-11	METAL CHIP	47K	5%	1/16W
R719	1-216-817-11	METAL CHIP	470	5%	1/16W
R720	1-216-817-11	METAL CHIP	470	5%	1/16W
R722	1-216-864-11	METAL CHIP	0	5%	1/16W
R725	1-216-864-11	METAL CHIP	0	5%	1/16W
R726	1-216-837-11	METAL CHIP	22K	5%	1/16W
R727	1-216-864-11	METAL CHIP	0	5%	1/16W
R805	1-216-845-11	METAL CHIP	100K	5%	1/16W
< SWITCH >					
S301	1-762-805-41	SWITCH, PUSH (1 KEY)			
S302	1-572-922-11	SWITCH, SLIDE (HOLD )			
S303	1-771-248-11	SWITCH, TACTILE (VOL+)			
S304	1-771-248-11	SWITCH, TACTILE (VOL-)			
< VIBRATOR >					
X301	1-795-909-11	VIBRATOR, CERAMIC (SMD) 8.46MHz			
X401	1-795-561-21	VIBRATOR, CERAMIC 16.9344MHz			

MISCELLANEOUS					

9	1-688-839-11	PWB, FLEXIBLE			
11	1-805-178-11	DISPLAY PANEL, LIQUID CRYSTAL			
△ 102	X-3380-950-1	OPTICAL PICK-UP (DAX-25E)			
M901	A-3180-965-A	MOTOR ASSY, TURN TABLE (SPINDLE)			
M902	A-3180-966-A	MOTOR ASSY, SLED (SLED)			

The components identified by mark △ or dotted line with mark △ are critical for safety. Replace only with part number specified.	Les composants identifiés par une marque △ sont critiques pour la sécurité. Ne les remplacer que par une pièce portant le numéro spécifié.
--	--

Ref. No.	Part No.	Description	Remarks
		ACCESSORIES *****	
	1-417-362-11	CONNECTING PACK, CAR (ZV71C,ZV77C)	
△	1-477-496-21	ADAPTOR, AC (AC-ES455K) (E33)	
△	1-477-497-21	ADAPTOR, AC (AC-ES455K) (ZV77D:KR)	
△	1-477-499-21	ADAPTOR, AC (AC-ES455K) (CH)	
△	1-477-500-21	ADAPTOR, AC (AC-ES455K) (ZV77:AEP,E18/ZV77D:AEP,E18)	
△	1-477-501-21	ADAPTOR, AC (AC-ES455K) (ZV77:UK/ZV77D:HK)	
△	1-477-502-21	ADAPTOR, AC (AC-ES455K) (ZV77:CND/ZV77D:TW)	
△	1-477-503-21	ADAPTOR, AC (AC-ES455K) (ZV77:AUS)	
	1-477-744-12	REMOTE COMMANDER (RC-Z1C002) (ZV77D)	
	1-542-514-11	HEADPHONE (HP-M070) (ZV77/ZV77C)	
	1-542-516-11	HEADPHONE (HP-M061) (ZV71C)	
	1-542-517-11	HEADPHONE (HP-M046S) (ZV71)	
	1-542-529-11	HEADPHONE (HP-170) (ZV77D)	
△	1-569-007-12	ADAPTOR, CONVERSION 2P (E33)	
	1-792-970-41	CORD, CAR BATTERY (DCC-E2455) (ZV71C,ZV77C)	
	3-252-375-01	TAPE,MAGIC (ZV71C,ZV77C)	
	3-252-434-11	MANUAL, INSTRUCTION (CAR KIT) (ZV71C,ZV77C)	
	3-253-769-11	MANUAL, INSTRUCTION(A) (ENGLISH,FRENCH) (ZV77:AEP,UK,E33,AUS/ZV77C/ZV77D:AEP)	
	3-253-769-21	MANUAL, INSTRUCTION(A) (GERMAN,ITALIAN) (ZV77:AEP/ZV77D:AEP)	
	3-253-769-31	MANUAL, INSTRUCTION(A) (SPANISH,PORTUGUESE) (ZV77:AEP,E33/ZV77C/ZV77D:AEP)	
	3-253-769-41	MANUAL, INSTRUCTION(A) (HUNGARIAN,POLISH) (ZV77:AEP/ZV77D:AEP)	
	3-253-769-51	MANUAL, INSTRUCTION(A) (CZECH,RUSSIAN) (ZV77:AEP/ZV77D:AEP)	
	3-253-771-11	MANUAL, INSTRUCTION(C) (ENGLISH,FRENCH) (ZV77:CND)	
	3-253-771-21	MANUAL, INSTRUCTION(C) (ENGLISH) (ZV71/ZV71C)	
	3-253-910-11	MANUAL, INSTRUCTION (TRADITIONAL CHINESE) (HK,TW)	
	3-253-910-21	MANUAL, INSTRUCTION (CHINESE) (ZV77:E18/ZV77D:E18,CH)	
	3-253-910-31	MANUAL, INSTRUCTION (KOREAN) (ZV77D:KR)	

The components identified by mark △ or dotted line with mark △ are critical for safety. Replace only with part number specified.

Les composants identifiés par une marque △ sont critiques pour la sécurité. Ne les remplacer que par une pièce portant le numéro spécifié.

