

# **SERVICE MANUAL**

**AKAI AMPLIFIER**

**MODEL AA-8000**



## TABLE OF CONTENTS

I.	SPECIFICATIONS .....	1
II.	CONTROLS AND CONNECTIONS.....	2
III.	TUNER AND AMPLIFIER ADJUSTMENT....	4
	1. POWER AMPLIFIER CIRCUIT ADJUSTMENTS	
	2. ADJUSTMENT OF PROTECTIVE CIRCUIT FOR POWER TRANSISTORS	
	3. TUNER SECTION ADJUSTMENTS	
IV.	TROUBLE SHOOTING CHART .....	9
V.	REMOVALS DISASSEMBLE & DIAL CORD STRINGS .....	11
VI.	COMPOSITE VIEW OF COMPONENTS .....	12
VII.	CONNECTION DIAGRAM .....	17
VIII.	SCHEMATIC DIAGRAM	

# I. SPECIFICATIONS

## TUNER SECTION

- FREQUENCY RANGE : FM : 88 to 108 MHz.  
AM : 530 to 1605 KHz.
- SENSITIVITY : FM : 2.0  $\mu$ V (98 MHz, 100% Mod.  
3% Dis. at 300 $\Omega$ ).  
AM : 20  $\mu$ V (1000 KHz, 30% Mod.  
10% Dis. with external antenna).
- S/N RATIO : FM : Better than 60 dB.  
AM : Better than 40 dB.
- HARMONIC DISTORTION : FM : Less than 0.8% (400 Hz, 100% Mod.)  
AM : Less than 3%.
- IMAGE FREQUENCY REJECTION : FM : Better than 60 dB (98 MHz).  
AM : Better than 60 dB (1000 KHz).
- FM MULTI-SEPARATION : Better than 30 dB (400 Hz).
- ANTENNA : FM : 300 $\Omega$ , 75 $\Omega$  (with external antenna).  
AM : Ferrite bar antenna  
(with external terminal).

## POWER AMPLIFIER SECTION

- POWER OUTPUT : Music power : 120W (60W/60W) at 8 $\Omega$ .  
Rated power : 90W (45W/45W) at 8 $\Omega$ .
- FREQUENCY RESPONSE : Phono : RIAA ( $\pm$ 1.5 dB).  
Tape, AUX : 20 to 50,000 Hz - 3 dB.
- S/N RATIO : Phono : Better than 60 dB.  
Tape, AUX : Better than 70 dB.
- HARMONIC DISTORTION : Less than 0.3% (45W/8 $\Omega$  1 KHz).
- INTER MODULATION : 0.3% (45W/8 $\Omega$ ).
- INPUT SENSITIVITY : Phono : 3.0 mV with 50 K $\Omega$ .  
Tape, AUX : 150 mV with 100 K $\Omega$ .
- OUTPUT TERMINALS : REC. Out : -15  $\pm$  2 dB (140 mV).  
DIN. Out : -30  $\pm$  2 dB (24 mV).  
SPEAKER OUT : (A.B).
- TONE CONTROL : Bass : 100 Hz  $\pm$  10 dB.  
Treble : 10 KHz  $\pm$  10 dB.
- LOUDNESS CONTROL : 100 Hz + 6 dB.  
10 KHz + 6 dB.

## OTHER

	Qty.
FE Transistor	1
Silicon Transistor	51
Silicon Diode	14
Germanium Diode	21
V.C. Diode	1
Thermistor	2

## POWER SUPPLY

- POWER SOURCE : 100V/110V/120V/200V/220V/240V,  
50/60 Hz.
- POWER CONSUMPTION : 30W no signal  
200W maximum

## DIMENSIONS

- DIMENSIONS : 5-1/2" x 18-1/8" x 14"  
(140 x 460 x 355 mm)
- WEIGHT : 33 lbs. (15 kg) without case.

## II. CONTROLS & CONNECTION

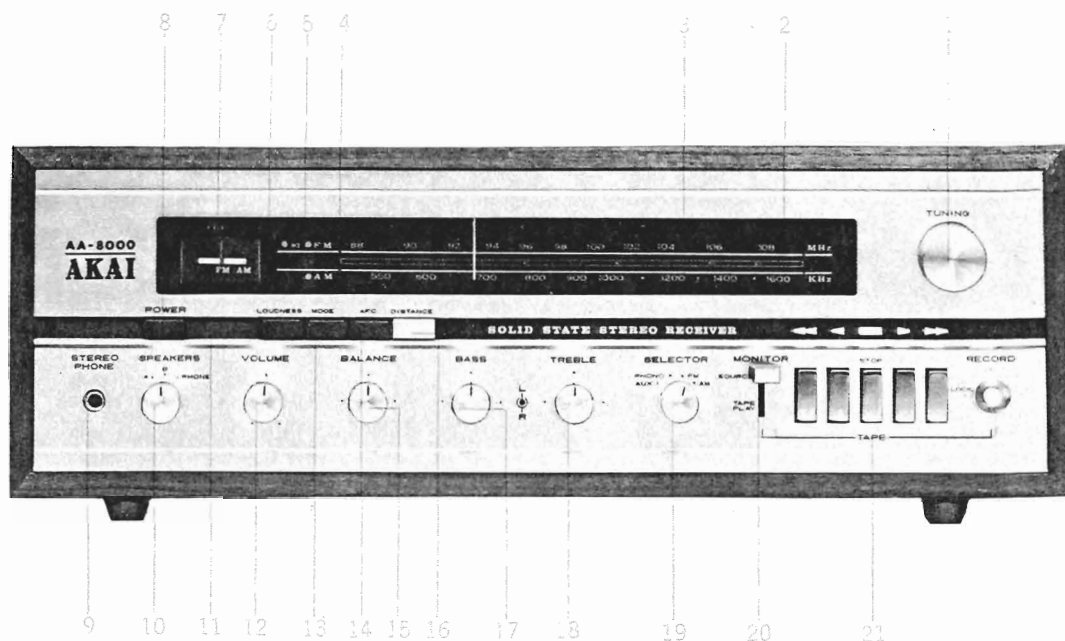

### CONTROLS

- ① TUNING KNOB : Select the channel.
- ② FM DIAL SCALE : Choose FM broadcast, Unit MHz (mega hertz).
- ③ AM DIAL SCALE : Choose AM broadcast. Unit in KHz (kilo hertz).
- ④ AM INDICATOR : The pilot lamp lighting, the reception of AM broadcast will be possible.
- ⑤ FM INDICATOR : The pilot lamp lighting, the reception of FM broadcast will be possible.
- ⑥ STEREO INDICATOR : On receiving FM broadcast, indicating stereo broadcast, by the pilot lamp.
- ⑦ TUNING METER : Indicate the tuning effect ;  
AM : The pointer stands still at the right limit of the meter, meaning the tuning is perfect.  
FM : The pointer stands still at the center of the meter, meaning the tuning is perfect.
- ⑧ POWER SWITCH : Switch in the power by soft finger touch.
- ⑨ ST. PHONE JACK : Insert the headphone plug as far in as it can go.
- ⑩ SPEAKER SYSTEMS SELECTOR : Select speaker system. At the PHONE position, SPEAKER is off and only PHONE remains. PHONE always can be listened, not in connection with this switch.
- ⑪ LOUDNESS SWITCH : Compensate for insufficient sound volume of bass and treble, during low-volume operation.
- ⑫ VOLUME CONTROL : Adjust the volume.
- ⑬ ST. MODE SWITCH : Shift from monaural to stereo in ON position.
- ⑭ AFC SWITCH : Eliminate the FM tuning distortion. Set this switch in OFF position at the beginning of the performance, and afterward in ON position so as to avoid distortion.
- ⑮ BALANCE CONTROL : Balance the volume of each of the left and right speakers.
- ⑯ DISTANCE : ON reception distant broadcast or weakwave broadcast, raise sensibility by setting to ON position.
- ⑰ BASS CONTROL : Strengthen the bass, and adjust the damping. (outside-R, inside-L)
- ⑱ TREBLE CONTROL : Strengthen the treble and adjust the damping. (outside-R, inside-L)
- ⑲ SELECTOR SWITCH : Select the input.
- ⑳ MONITOR SWITCH : Monitor the progress of recording with a three-head tape recorder when this switch is set in "TAPE PLAY" position. Used also for playback.
- ㉑ TAPE RECORDER REMOTE CONTROL : To operate this amplifier connecting with AKAI MODEL X-360 (D), a tape recorder can be remotely controlled by the side of the amplifier by connecting the REMOTE CABLE.

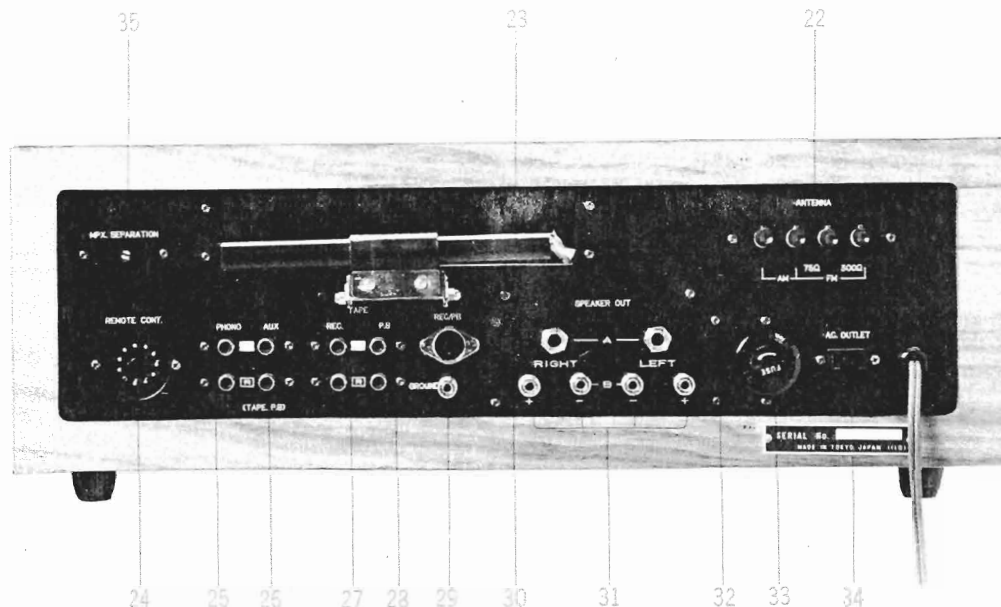

## CONTROLS

- ②② ANT. TERMINAL : AM ; (a-b) Used, for example, with the radio wave not strong enough to be caught by BAR ANTENNA ②③.  
FM ; Receive FM broadcast. Connected directly with a 300 ohms antenna (c-d). Where the wave is strong enough, the feeder antenna will do. On the occasion of connecting with antenna by using 75  $\Omega$  coaxial cable instead of the feeder, connect to (b-c). (center line→c)
- ②③ AM BAR ANTENNA : Receive AM broadcast. Before use pull it out. When moving the amplifier elsewhere, set it back so as to protect it from possible failure.
- ②④ REMOTE CONTROL CONNECTOR : To operate AKAI MODEL X-360(D) using this amplifier, connect the special cord (accessory) to this connector.
- ②⑤ PHONO JACK : Used with the low input cartridge (2 to 5 mV) inserted. Keep this jack in inserted position by a short pin when not in use.
- ②⑥ AUX JACK : Inserted by relatively high voltage input, such as radio tuner, output from the amplifier of a tape recorder and record player with ceramic or crystal cartridge. (150 mV)
- ②⑦ TAPE-REC. JACK : Connected to the input terminal of a tape recorder. The recording source selected by SELECTOR SWITCH ①⑨ .
- ②⑧ TAPE-P.B. JACK : Connected to the output terminal of a tape recorder, there-by monitoring the progress of performance by MONITOR SWITCH ②⑩ .
- ②⑨ GROUNDING TERMINAL : Ground the phono motor and arm of a record player. This ground connection occasionally invites noise ; choose either this or the ground connection of PHONO JACK ②⑤ , as the case may be.
- ③⑩ DIN CONNECTOR : Capable of the functions of both TAPEREC. JACK ②⑦ and TAPE-P.B. JACK ②⑧ , if jointly used with a tape recorder furnished with the corresponding connections.
- ③① SPEAKER OUTPUT TERMINAL : Supply the output to the speaker. Fit the plus and minus terminal to the corresponding polarity of the speaker. Use a speaker with the impedance preferably of more than 8 ohms.
- ③② SPEAKER OUTPUT JACK : Connected by the 2P plug to the speaker, not allowing the output into SPEAKER OUTPUT TERMINAL ③① .
- ③③ VOLTAGE SELECTOR & FUSE : The power voltage can be switched in six steps ranging from AC 100 to 240 volts. Fuse must be as follows :
- ③④ AC OUTLET : Power supply for record player or tape recorder. This power supply provides up to 300 watts. Note that this power is not interlocked with POWER SWITCH
- ③⑤ FM SEPARATION CONTROL : Adjust the separation of the volume of each of the left and right speakers. Do not turn it unless positively necessary, as it is completely adjusted when shipped.

### III. TUNER & AMPLIFIER ADJUSTMENT

#### 1. POWER AMPLIFIER CIRCUIT ADJUSTMENTS

In case power amplifier circuit has been repaired or power transistors have been replaced, the following adjustments are necessary for each channel :

##### 1-1 No-signal Current Adjustment of Power Amplifier

- Connect a 1.5 A full scale DC Ammeter in place of the protector fuse in the left channel amplifier. An Ammeter with range selector covering 1.5 ~ 0.1 A is recommended.
- Set VOLUME Knob (VR-404) on the front panel to the full counterclockwise (minimum) position.
- Turn Potentiometer VR-202 (1 K $\Omega$ B, L. CH.) of the power amplifier printed board full counterclockwise, and VR-201 (100 K $\Omega$ B, L. CH.) to the half way position of its movable range.
- Depress the power switch to "ON" position, and adjust VR-202 so that the Ammeter indicates 50 mA (0.05 A).
- Adjust VR-252 of the right channel amplifier in the same way.

##### 1-2 DC Balance Adjustments

Adjust the DC Balance after completing current adjustment of the power amplifier.

- Connect the audio oscillator to the AUX. input terminals of both the left and right channel amplifiers, and supply a 1,000 Hz sine wave, setting the oscillator output to zero.
- Connect an 8  $\Omega$  60 W resistor to the left and right channel speaker terminals, and connect the oscilloscope across this resistor (see Fig. 1).
- Set VOLUME Knob on the front panel to the full clockwise (maximum position).
- Gradually increase the output of the audio oscillator until the wave form on the oscilloscope (see Fig. 2) begins to be clipped. Adjust the left channel potentiometer VR-201 (100 K $\Omega$ ) and the right channel VR-251 (100 K $\Omega$ ) so that both upper and lower peaks of the wave forms begin to be clipped simultaneously at the same point of the curve. In case an audio oscillator or an oscilloscope is not available, adjust Potentiometer VR-201 (L.CH.) and VR-251 (R.CH.) so that the voltage between the plus side of the large capacity condenser which is connected to the speaker and ground is half of the supply voltage (80 V). At this time, the VOLUME knob on the front panel should be kept at minimum position

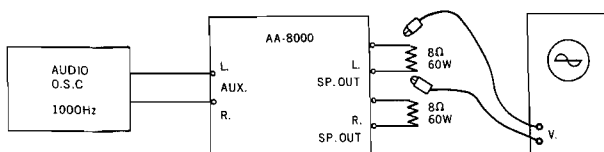

Fig. 1

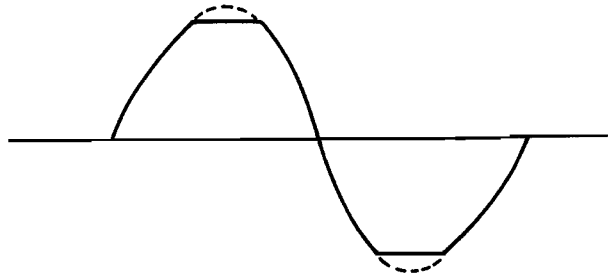

Fig. 2

#### 2. ADJUSTMENT OF PROTECTIVE CIRCUIT FOR POWER TRANSISTORS

Power transistors will be destroyed by an over-current when the output terminals of the speaker are shorted. To protect them, a protective circuit automatically operates to cut off the supply voltage in the driver stage and control the current to the power transistors.

- Connect instruments as shown in Fig. 1 and use a VTVM in place of the oscilloscope.
- Turn VOLUME knob on the front panel to the fully wound clockwise (maximum position).
- Connect a 4  $\Omega$  60 W resistor to the speaker output terminals as a load, and a VTVM across the resistor.
- Set Potentiometer VR-101 (100 K $\Omega$ B), the adjusting operation point of the protective circuit, to the fully wound counterclockwise position.
- Gradually increase the output of audio oscillator, which is connected to AUX terminals, until the VTVM indicates 11.5 V. At this position, adjust Potentiometer VR-101 to obtain the speaker output critical point of zero.
- Then, exchange the load resistor at the speaker output terminals with an 8  $\Omega$  45 W resistor. Adjust the output of the audio oscillator so that the speaker output is 60 W (the indication of VTVM : 19 V). Make sure that the protective circuit does not operate.
- Then, adjust the oscillator output so that the VTVM indicates 8 V. At this position, check to see whether the protective circuit operates properly while shorting speaker terminals.

#### 3. TUNER SECTION ADJUSTMENTS

3-1 FM IF Circuit (AA-506 printed board) Adjustment  
FM-IF circuit adjustment should be made with calibrated instruments because this adjustment has a great influence on tone quality, separation, S/N, etc. in Stereo FM reception.

##### (1) Instrument Connection

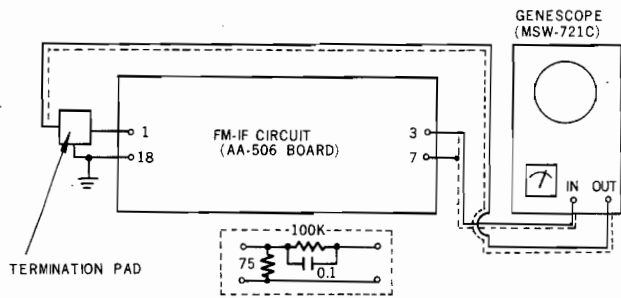

Fig. 3

- Connect the output lead of the Genescope to test points (1) and (18) on the IF printed board (AA-506).
  - Connect the input lead of the Genescope to test points (3) and (7).
  - Set FREQUENCY BAND of the Genescope to B (9.5 MHz ~ 11.5 MHz).
  - Adjust V-POSITION, SWEEP-WIDTH and CENTER-FREQUENCY respectively so that the wave forms are in the center of the oscilloscope.
  - Set STEREO MODE switch on the front panel of AA-8000 to OUT (MONO) position. DISTANCE switch to IN position.
- (2) IF Transformers (10.7 MHz) Adjustments

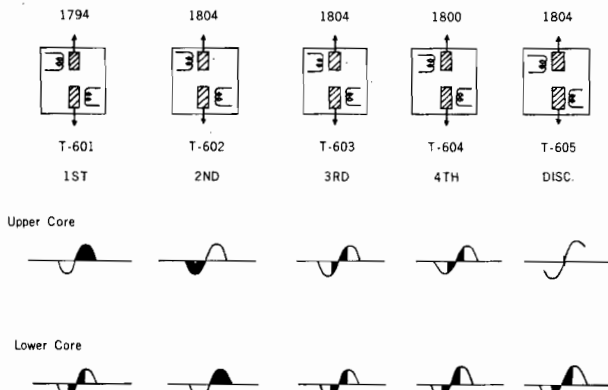

Fig. 4

Adjustment of cores of FM-IF (10.7 MHz) transformers Adjust with 40 dB (100  $\mu$ V) output level of the Genescope. Adjust the upper and lower cores of T-601 to T-605 to obtain the wave form shown in Fig. 5 (A). Since this wave form adjustment affects the maximum sensitivity and distortion, make the linearity and peak wave-form value as high as possible. Then set the Genescope output level to 100 dB, and make sure that the waveform is symmetrical on both sides.

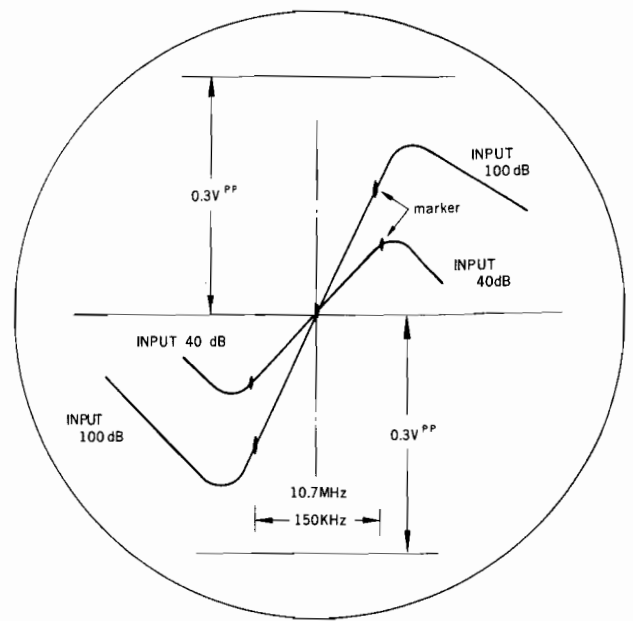

Fig. 5

### 3-2 Connection with Front End

#### (1) Instrument Connections

Use the same instruments as used in item 1), and connect the Genescope output lead to test points (3) and (5) on the front end.

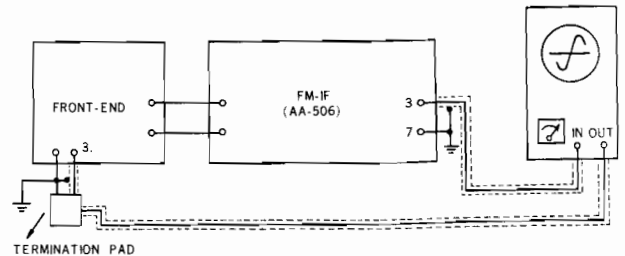

Fig. 6

- Turn the core of the output transformer T<sub>2</sub> on the front end so that the horizontal stripes visible in the center of the waveform in Fig. 8 are maximum in width and are located in the center of the S-shaped curve. At this time, the horizontal stripe width should be symmetrical about the center line.

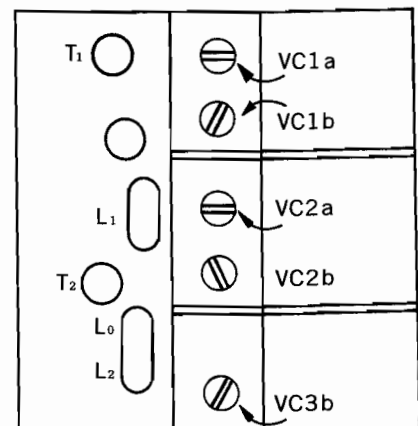

Fig. 7

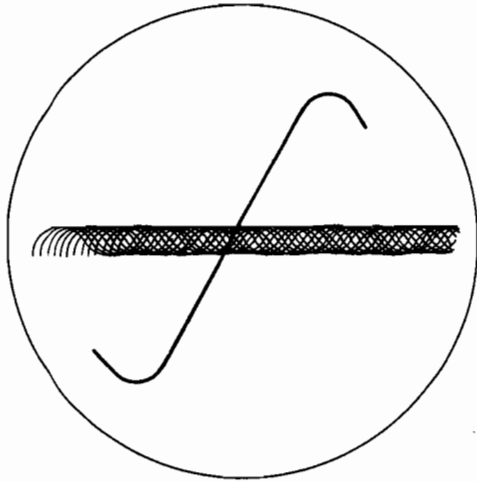

Fig. 8

### 3-3 Adjustment of FM Reception Frequency Range

#### (1) Instrument Connections

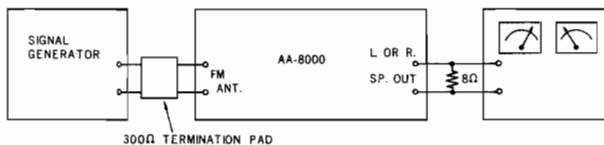

Fig. 9

- Connect the Signal Generator (MSG-276A) output lead to the FM antenna terminals of AA-8000 through the 300  $\Omega$  terminal pad.
- Set SELECTOR switch of AA-8000 to the FM position, STEREO MODE switch to IN and AFC to OUT.
- Connect an 8  $\Omega$  60 W dummy load to the speaker output terminals of both R and L channels, and connect a distortion meter to the dummy load of either L or R channel.

#### (2) Adjustments

- Set the Signal Generator frequency to 87.5 MHz (internal modulation 400 Hz, 100%), and the output to 60 dB (1 mV).
- Set the tuning dial of AA-8000 to the left end. Turn VOLUME half-way and adjust  $L_2$  of the front end (see Fig. 7) so that the Distortion meter level indicates maximum.
- Set the Signal Generator frequency to 108.5 MHz. Set the tuning dial of AA-8000 to the right end. Adjust  $C_0$  (see Fig. 7) on the front end so that the Distortion meter level indicates maximum.
- Repeat procedures b) and c) two or three times.

### 3-4 FM Tuner Tracking Adjustment

#### (1) Instrument Connections

Use the same instruments as used in item 3-3 (Fig. 9), and connect them in the same way.

#### (2) Adjustments

- Set the signal generator frequency to 90.0 MHz (internal modulation 400 Hz, 100%), and the output to 60 dB (1 mV).

- Turn the tuning dial of AA-8000 to receive the 90.0 MHz signal. (Set SIGNAL GENERATOR to the position where the distortion factor on the meter is approximately 3%.)
- Adjust the cores of  $L_1$  and  $T_1$  (see Fig. 7) on front end of AA-8000 so that the Distortion meter level indicates maximum and the distortion factor is minimum.
- Set the Signal Generator frequency to 105 MHz, then turn the tuning dial of AA-8000 to receive this signal. Adjust the trimmer condensers VC1a and VC2a of the tuning variable condenser in the front end so that the Distortion meter level indicates maximum and minimum distortion factors.
- Repeat procedures c) and d) two or three times.

### 3-5 Tuning Indicator Check

Use the same instruments as used in item 3-3 and connect them in the same way. (Fig. 9) Set the signal generator frequency to 98 MHz, and the output to 60 dB (1 mV). Turn the tuning dial of AA-8000 to receive this signal and make sure that the tuning indicator deflects more than 5 mm to both sides from beginning to end of signal reception.

### 3-6 S.C.A. Filter Adjustment

#### Instrument Connections

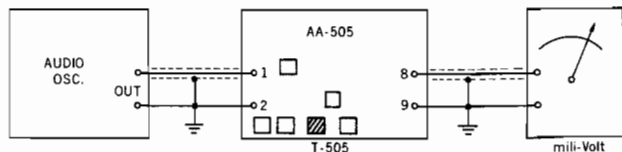

Fig. 10

- Connect the audio oscillator output to terminals (1) and (2) of MPX printed board (AA-505) and a milli-voltmeter to terminals (8) and (9).
- Set the audio oscillator frequency to 67 KHz, and the output to 0.35 V.
- Adjust the core of T-505 so that the milli-voltmeter indicates minimum.

### 3-7 19 KHz Filter and Pilot Lamp Sensitivity Adjustment Instrument Connections

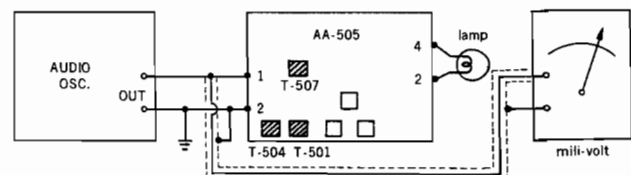

Fig. 11

- Connect the AM signal generator to the and the milli-voltmeter to terminals (1) and (2) of MPX printed Board AA-505.
- Watch the red lamp (12V, 20 mA) on the front panel of AA-8000 (on the right side of the tuning indicator).



- c) Set the audio oscillator frequency to 19 KHz and increase the oscillator output until the lamp lights.
- d) Decrease the oscillator output so that the lamp lights at the minimum output by adjustment of the core of T-507.
- e) Then, adjust T-501 and T-504 as outlined above.
- f) When adjustments outlined above are complete, the light begins to light at approximately 5 ~ 6 mV of the oscillator output. The lamp should be lit below 10 mV.

### 3-8 Separation Adjustment Instrument Connections

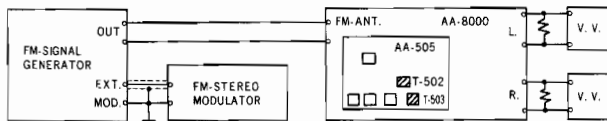

Fig. 12

- a) The PILOT signal 19 KHz of an FM stereo modulator set to 10% modulation and the MAIN signal (L + R) set to 400 Hz, 90%. Then connect output to EXT. MOD. terminals of the FM signal generator.
- b) Set the FM Signal Generator to EXT. MOD., and its modulation at 100%
- c) Set the FM Signal Generator frequency to 98 MHz and the output voltage to 60 dB (1 mV). Connect output to the FM-ANT terminals of AA-8000.
- d) Connect an  $8 \Omega$  60 W dummy load resistor to the speaker terminal of AA-8000 and a milli-voltmeter (VTVM) to both terminal ends.
- e) Receive signal from the FM Generator by tuning the AA-8000. Adjust VOLUME on the front panel so that the milli-voltmeter indicates +10 dBm. (Stereo Mode)
- f) Turn MPX-SEPARATION variable resistor VR-501 located at the left end of the rear panel of AA-8000 fully clockwise.
- g) Set the FM stereo modulator signal to "MAIN" (L + R), and check whether the outputs of both channels are balanced. If they are out of balance, adjust by turning BALANCE knob on the front panel.
- h) Set the FM stereo modulator signal to "L" and adjust T-502 and T-503 so that the milli-voltmeter connect to R CH. indicates minimum. Then adjust VR-501 so that R CH. output becomes minimum.
- i) Set the FM stereo modulator signal to R and note the indication of the milli-voltmeter connected to L CH. Then re-adjust T-502 and VR-501 so that the leakages of R CH. and L CH. are as closely balanced as possible.

### 3-9 AM-IF Circuit Adjustment Instrument Connections

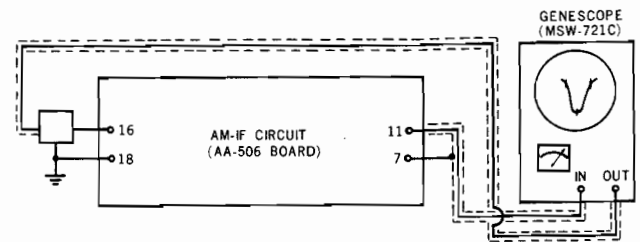

Fig. 13

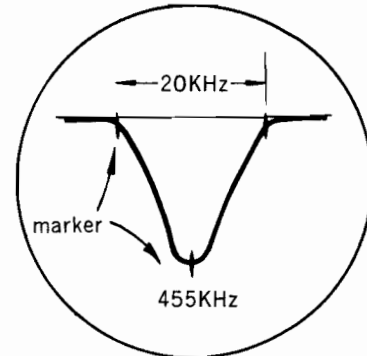

Fig. 14

- a) Connect the Genescope output lead to test points (16) and (18) of the IF printed circuit board (AA-506).
- b) Connect the Genescope input lead to test points (11) and (7).
- c) Set the Genescope FREQUENCY BAND to A (400-500 KHz). Adjust V-POSITION, SWEEP-WIDTH and CENTER FREQUENCY respectively so that the wave form is at the center of the oscilloscope.
- d) Turn SELECTOR switch on the front panel of AA-8000 to AM position, and VOLUME to minimum position.
- e) Adjust the Genescope output to approximately 50 dB ( $310 \mu V$ ). Then adjust the upper and lower cores of T-652, T-653 and T-654 so that the wave forms shown in Fig. 14 are obtained. Adjust them so that the center marker of the three markers divide the wave forms into two symmetrical parts, and the highest peak value is obtained.

### 3-10 AM Receiving Frequency Range Adjustment (1) Instrument Connections

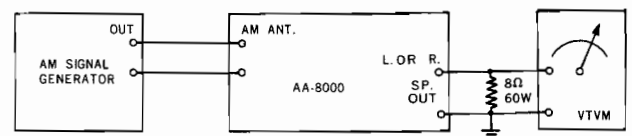

Fig. 15

- a) Connect the AM signal generator to the AA-8000 AM antenna terminals. Connect an  $8 \Omega$  60 W dummy load resistor to left and

right channel speaker terminals and connect a milli-voltmeter (VTVM) to both ends. Keep the VOLUME turned half-way.

- b) After setting AA-8000 to AM, set the dial to the left end. Set the AM signal generator to 400 Hz, 30% internal modulation, frequency to 525 KHz, and output to 40 dB (100  $\mu$ V).
- c) Adjust the core of AM local oscillator transformer T-651 on AM-IF printed board (AA-506) so that the milli-voltmeter indicates maximum.
- d) Then, turn the tuning dial of the AA-8000 to the right end. Set the AM signal generator frequency to 1,630 KHz and adjust trimmer condenser VC3b of the AM local oscillator variable condenser of the front end so that the milli-voltmeter indicates maximum.
- e) Repeat procedures c) and d) two or three times.

### 3-11 AM Tuner Tracking Adjustment

#### (1) Instrument Connections

Use the same instruments and connections as shown in 3-10 (Fig. 15).

#### (2) Adjustment

- a) Set the AM signal generator frequency to 600 KHz (internal modulation 400 Hz, 30%) and the output to 50 dB (310  $\mu$ V).
- b) Turn the dial of AA-8000 to receive the 600 KHz signal.
- c) Adjust the RF transformer to T-650 on the AM-IF printed board (AA-506) and core of the Ferrite Bar Antenna so that the milli-voltmeter which is connected to the speaker terminals indicates maximum.
- d) Next, set the AM signal generator frequency to 1,400 KHz, and turn the tuning dial of AA-8000 to receive the 1,400 KHz signal. Adjust trimmer condensers VC1b and VC2b which are variable condensers on the front end so that the milli-voltmeter indicates maximum.
- e) Repeat procedures c) and d) two or three times.

# IV. TROUBLE SHOOTING CHART

## NO SOUND

Symptom	REMARKS	
Defective speaker system.	<ul style="list-style-type: none"> <li>• Speaker cables open or shorted.</li> <li>• Speaker voice coil open.</li> </ul>	<ul style="list-style-type: none"> <li>• Check speaker terminals for looseness.</li> <li>• Repair or replace speaker.</li> </ul>
No electrical supply.	<ul style="list-style-type: none"> <li>• Absence of power supply.</li> <li>• Defective power switch.</li> <li>• Line cord plug has faulty contact or is disconnected.</li> <li>• Line fuse blown.</li> </ul>	
Blown fuse upon replacement.	<ul style="list-style-type: none"> <li>• Short in power transformer.</li> <li>• Shorted diodes for AA-501A or AA-501B.</li> <li>• Shorted electrolytic capacitors : C-101 ~ 108.</li> </ul>	<ul style="list-style-type: none"> <li>• Replace transformer.</li> <li>• Replace defective diodes.</li> <li>• Replace defective capacitors.</li> </ul>
Pilot lamp lights, but no sound from speaker.	<ul style="list-style-type: none"> <li>• Protection circuit in operation.</li> <li>• Speaker changeover switch at "PHONE".</li> <li>• "TAPER MONITOR" switch at "TAPE PLAY".</li> </ul>	<ul style="list-style-type: none"> <li>• Check speaker output terminals and leads for short.</li> <li>• Set to "A" or "B" position.</li> <li>• Set switch to "SOURCE".</li> </ul>
Internal Failure.	<ul style="list-style-type: none"> <li>• Inoperative B power source circuit.</li> <li>• Fuses F-102 and F-103 (protecting power transistors) blown.</li> </ul>	<ul style="list-style-type: none"> <li>• Secondary winding in power transformer open. Resistors R-101, R102 and R103 open.</li> <li>• Shorted power transistors TR-205, TR-206, TR-255 and TR-256.</li> </ul>
Sound from one channel only.	<ul style="list-style-type: none"> <li>• Improper position of balance control.</li> <li>• Defective audio circuit of the channel.</li> </ul>	<ul style="list-style-type: none"> <li>• Adjust balance control.</li> <li>• Check for defect by measuring voltages at check points, comparing them with normal channel.</li> </ul>

## LOW SOUND LEVEL

Symptom	REMARKS	
Low sound on both channels.	<ul style="list-style-type: none"> <li>• Defective power supply circuit.</li> </ul>	<ul style="list-style-type: none"> <li>• Check wiring and voltage.</li> </ul>
Low sound on one channel.	<ul style="list-style-type: none"> <li>• Defective speaker.</li> <li>• Discharged coupling capacitor.</li> </ul>	<ul style="list-style-type: none"> <li>• Replace Speaker.</li> <li>• Replace defective capacitor (s).</li> </ul>

## DISTORTION

Symptom	REMARKS	
Distorted sound on both channels.	<ul style="list-style-type: none"> <li>• Defective power supply circuit.</li> </ul>	<ul style="list-style-type: none"> <li>• Check AA-501A and AA-502B.</li> </ul>
Distorted sound on one channel.	<ul style="list-style-type: none"> <li>• Defective Speaker.</li> <li>• Leaky coupling capacitor (s).</li> <li>• Defective or unbalanced power transistors.</li> </ul>	<ul style="list-style-type: none"> <li>• Replace Speaker.</li> <li>• Replace defective capacitor (s).</li> <li>• Adjust or replace.</li> </ul>

## HUM AND NOISE

Symptom	REMARKS	
Excessive hum.	<ul style="list-style-type: none"> <li>• Discharged capacitor in power supply circuit.</li> <li>• Defective rectifying diodes in power supply circuit.</li> <li>• Defective transistor in power supply filter circuit.</li> </ul>	<ul style="list-style-type: none"> <li>• Check C-101 ~ C-108.</li> <li>• Check D-101 ~ D-104 and DD-101 ~ DD-104.</li> <li>• Replace TR-101 if shorted.</li> </ul>

Symptom	REMARKS	
Excessive noise.	<ul style="list-style-type: none"> <li>Defective transistor in pre-amplifier circuit.</li> <li>Defective volume control variable resistor.</li> </ul>	<ul style="list-style-type: none"> <li>Check TR-301 ~ TR-304, TR-351 ~ TR-354, TR-401, TR-451, TR-201 ~ TR-204 and TR-251 ~ TR-254.</li> <li>Check VR-404.</li> </ul>
Inoperative loudness control.	<ul style="list-style-type: none"> <li>Defective loudness circuit AA-504B.</li> </ul>	<ul style="list-style-type: none"> <li>Check C-407-8, C-457-8, R-409, R-459, and VR 404.</li> </ul>
Inoperative tone control.	<ul style="list-style-type: none"> <li>At "TREBLE"</li> <li>At "BASS"</li> </ul>	<ul style="list-style-type: none"> <li>Check C-403-4, CR-453-4, and VR-401.</li> <li>Check R-407, R-457, C-405-6, C455-6, and R-402.</li> </ul>

#### FM RECEPTION TROUBLE

Symptom	REMARKS	
No FM reception.	<ul style="list-style-type: none"> <li>FM front-end, FM-IF or MPX circuit defective.</li> </ul>	<ul style="list-style-type: none"> <li>Check SELECTOR switch. Check voltage of TR-601 ~ TR-605, and TR-501 ~ TR-507.</li> </ul>
Sound satisfactory but stereo indicator lamp not lit.	<ul style="list-style-type: none"> <li>Defective operation of stereo beacon circuit or defective lamp.</li> </ul>	<ul style="list-style-type: none"> <li>Check voltage of TR-508 ~ TR-511 on printed board AA-505. Replace lamp if defective.</li> </ul>
Incomplete separation during FM reception.	<ul style="list-style-type: none"> <li>Defective FM multiplex circuit.</li> </ul>	<ul style="list-style-type: none"> <li>Defective circuit of TR-501 ~ TR-507 on printed board AA-505.</li> <li>Adjust VR-501 with measuring equipment or stereo FM wave.</li> </ul>
Excessive noise.	<ul style="list-style-type: none"> <li>Weak broadcasting signal or weak input signal to amplifier.</li> </ul>	<ul style="list-style-type: none"> <li>Orient or replace antenna with a higher gain. Antenna feeder open or loosely connected.</li> </ul>
Intermittent noises.	<ul style="list-style-type: none"> <li>Due to automobile ignition noises.</li> </ul>	<ul style="list-style-type: none"> <li>Install FM antenna as far away from streets as possible.</li> </ul>
Noise increases during FM reception.	<ul style="list-style-type: none"> <li>Due to peculiar FM receiver noise when signal is very weak.</li> </ul>	<ul style="list-style-type: none"> <li>Set DISTANCE switch to ON. If sensitivity of FM receiver decreases, check or re-adjust FM-IF circuit.</li> </ul>

#### AM RECEPTION TROUBLE

Symptom	REMARKS	
No AM reception.	<ul style="list-style-type: none"> <li>Defective AM IF circuit AA-506.</li> </ul>	<ul style="list-style-type: none"> <li>Check voltage of TR-651 ~ TR-653. Check selector switch.</li> </ul>
Excessive Noise.	<ul style="list-style-type: none"> <li>Weak signal.</li> </ul>	<ul style="list-style-type: none"> <li>Use external antenna.</li> </ul>
Hum when tuned to broadcasting station.	<ul style="list-style-type: none"> <li>Due to transmission lines or generating noise of electrical apparatuses (e.g. fluorescent lamps, motors, etc.) nearby.</li> </ul>	<ul style="list-style-type: none"> <li>When bar antenna is used, reposition until noise is minimized. Reset AC cord plug.</li> </ul>
Buzzing Noise.	<ul style="list-style-type: none"> <li>Due to a TV set nearby.</li> </ul>	<ul style="list-style-type: none"> <li>Relocate amplifier.</li> </ul>

#### WHEN EXTERNAL INPUT IS USED (Tape recorder, recorder, etc.)

Symptom	REMARKS	
No sound or Increase of noise or Hum.	<ul style="list-style-type: none"> <li>Faulty connection.</li> </ul>	<ul style="list-style-type: none"> <li>Check connections and polarity referring to operator's manual.</li> <li>Check selector switch.</li> </ul>

# V.REMOVALS DISASSEMBLE & DIAL CORD STRINGS

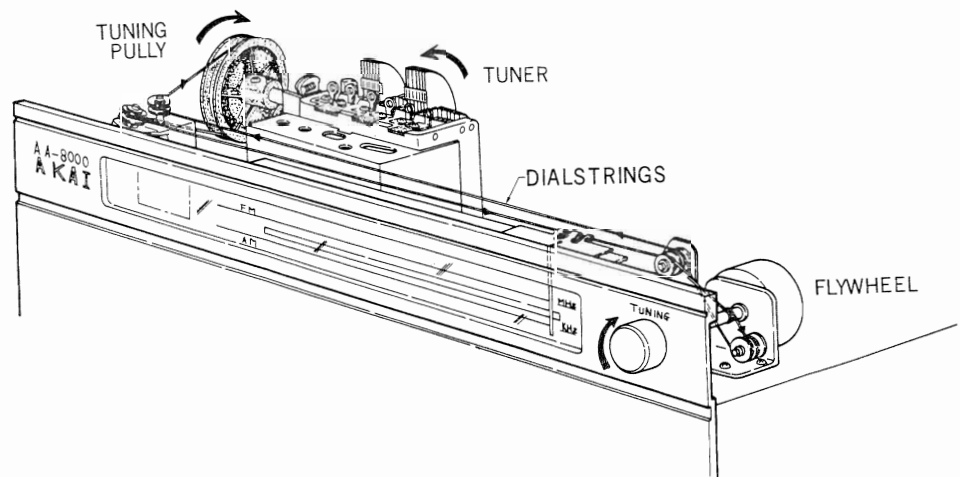
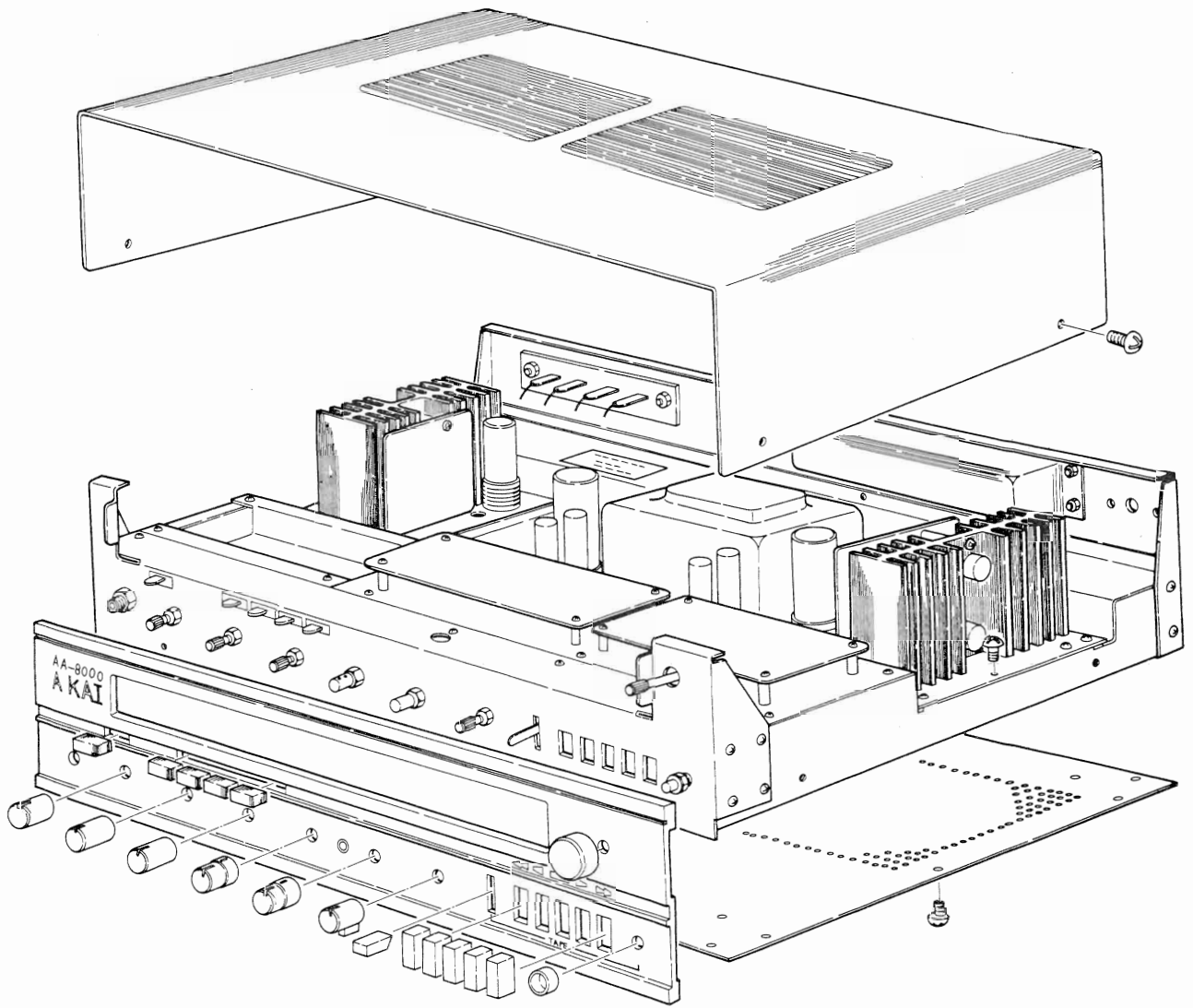

# VI. COMPOSITE VIEW OF COMPONENTS

POWER PRINTED CARD (AA-501A)

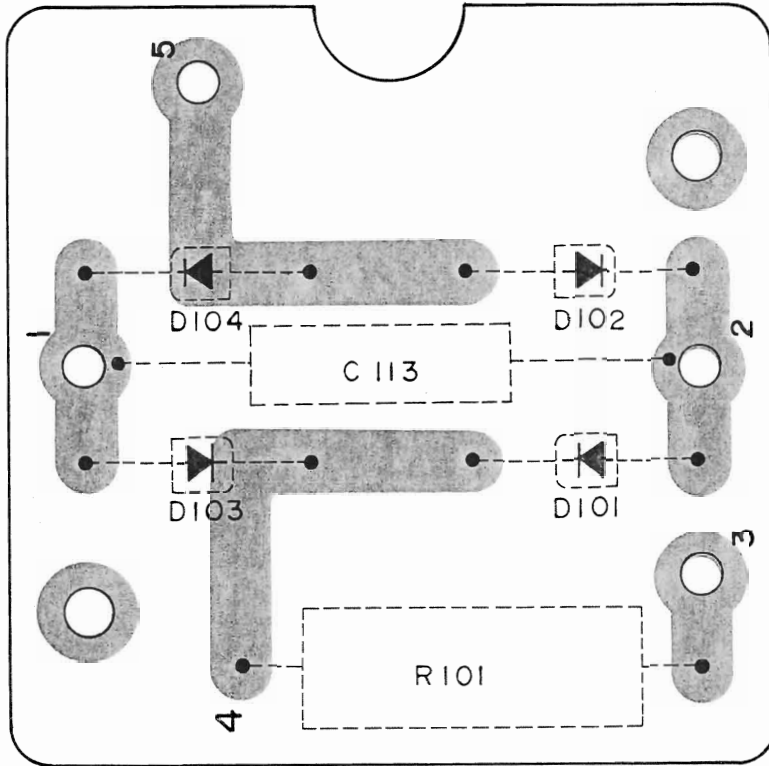

POWER PRINTED CARD (AA-501B)

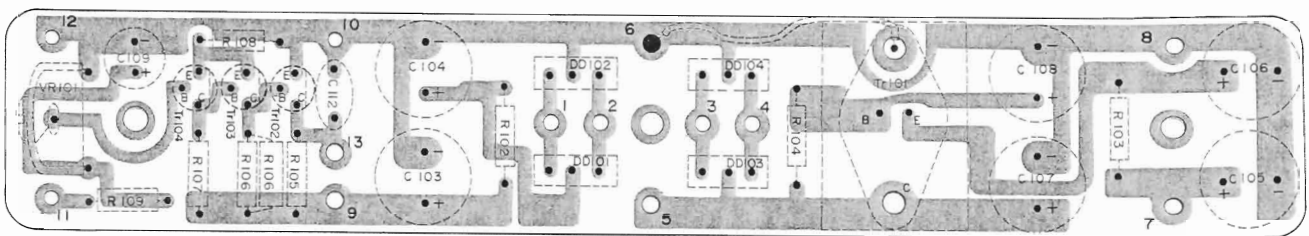

MAIN AMP. PRINTED CARD (AA-502)

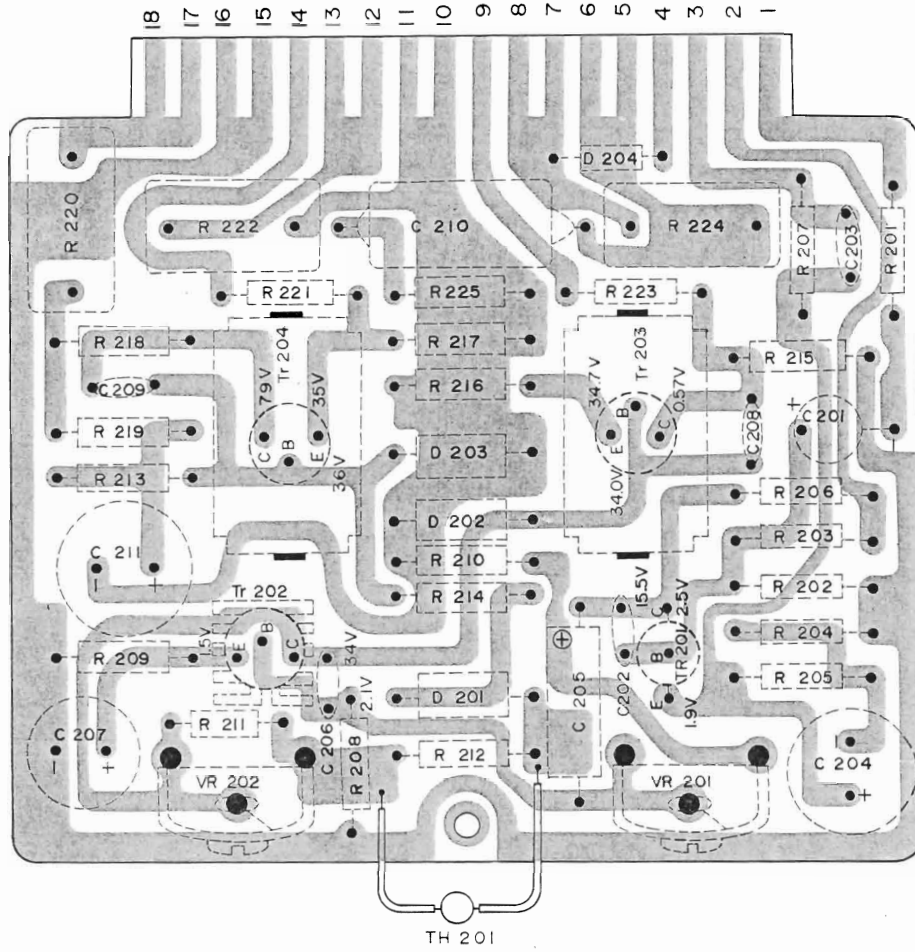

EQUALIZATION PRINTED CARD (AA-503)

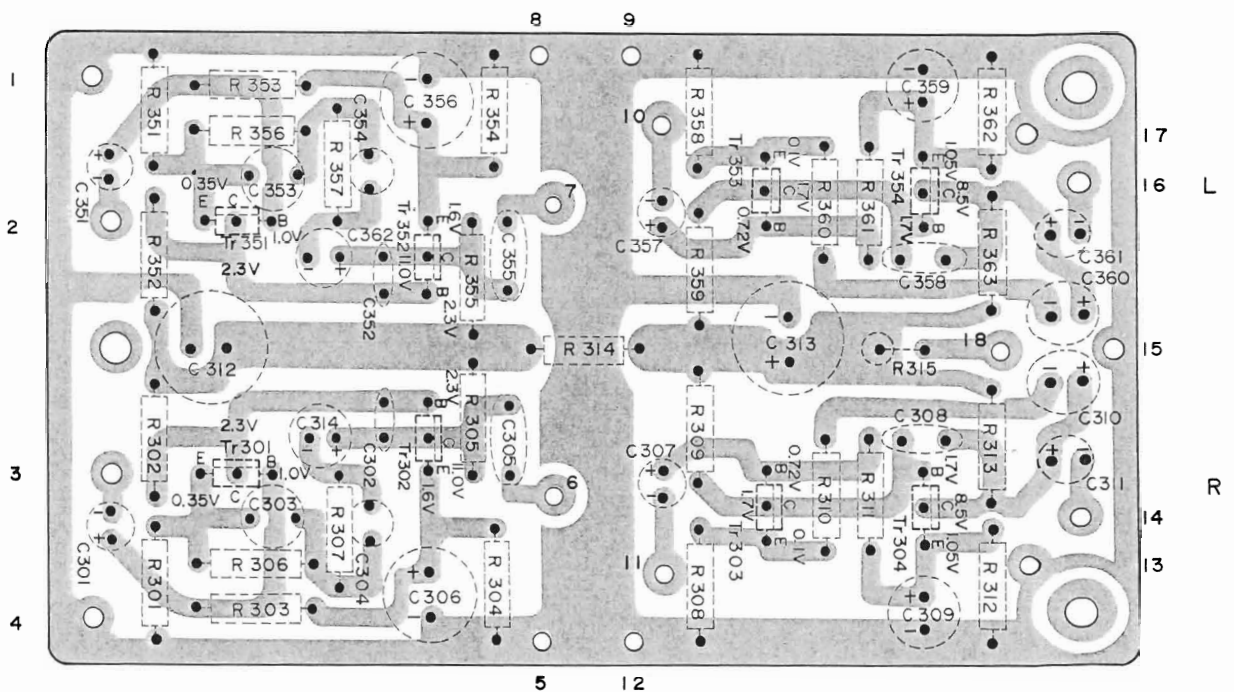

PRINTED CARD, FRONT CHASSIS (AA-504A)

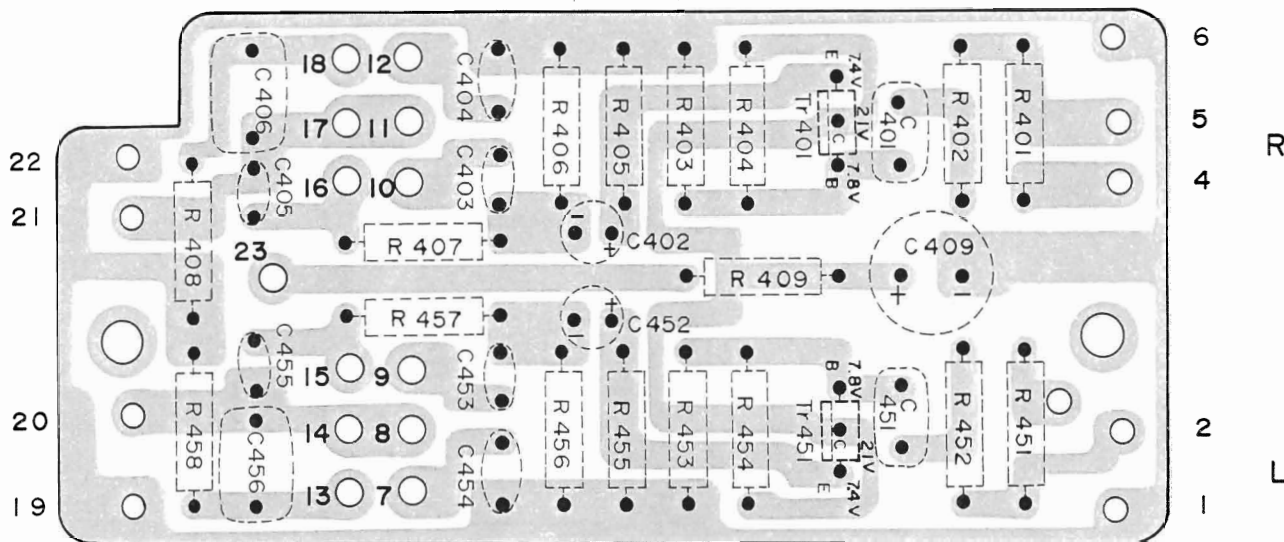

PRINTED CARD, FRONT CHASSIS (AA-504B)

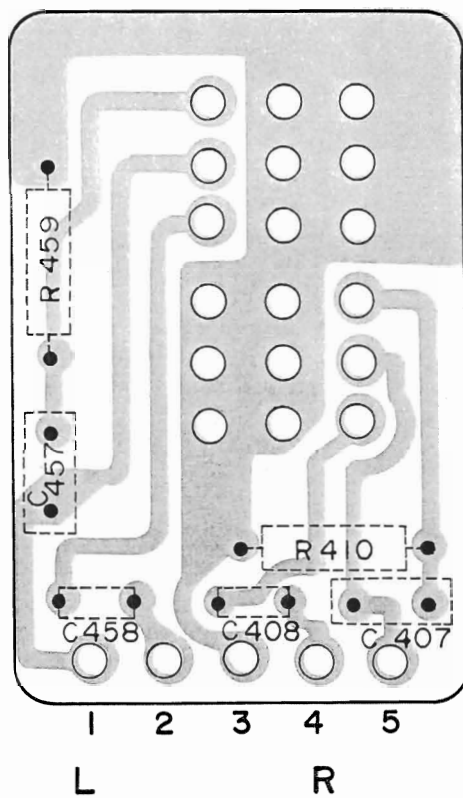



IFT PRINTED CARD (AA-506)

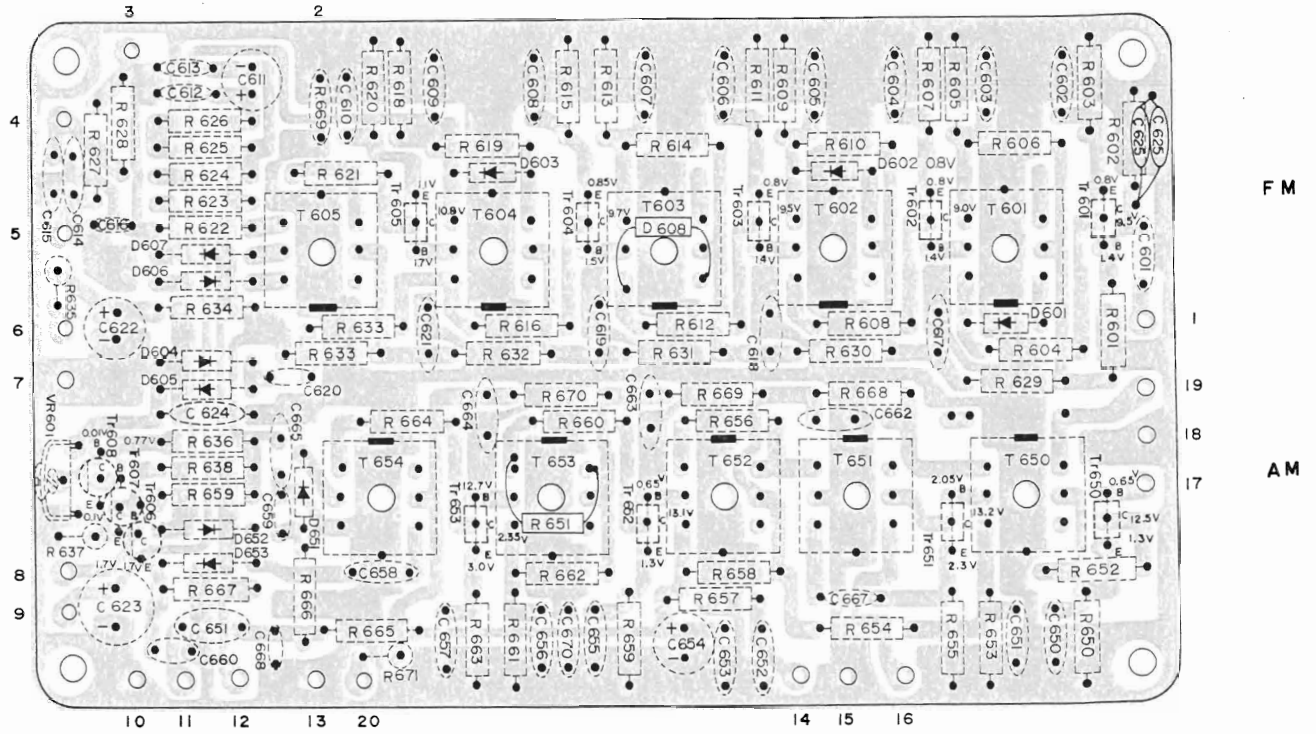

MPX PRINTED CARD (AA-507)

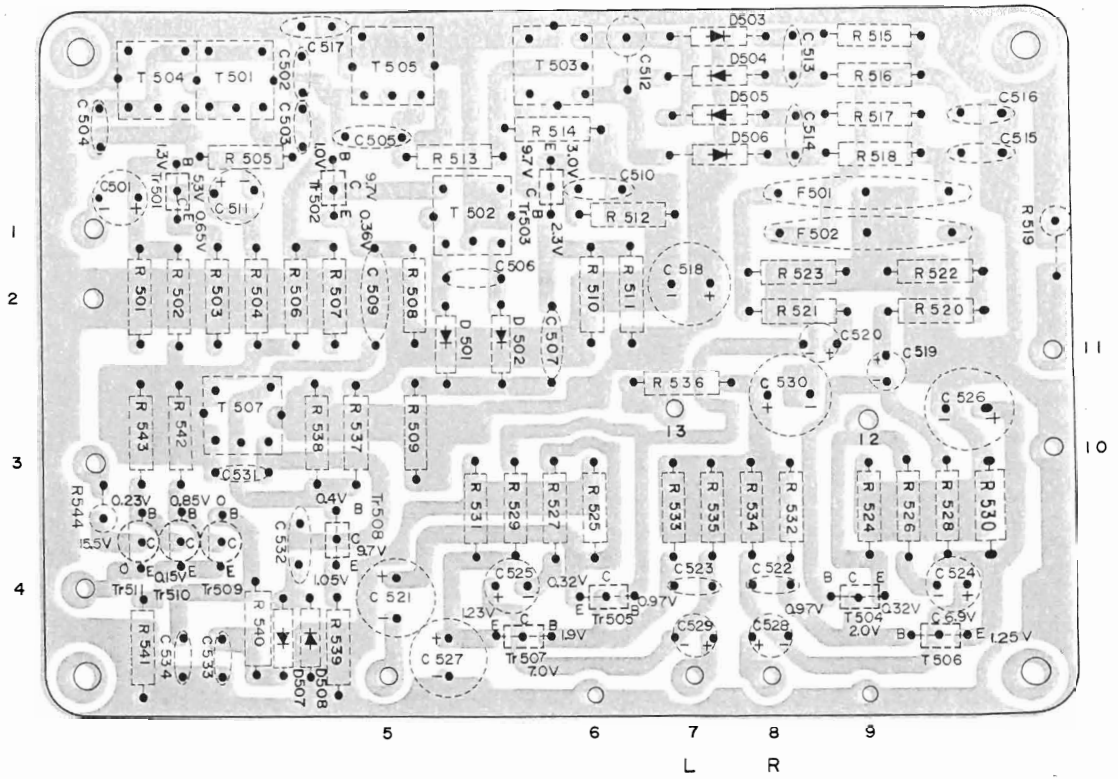

SPEAKER (Right)

VII. CONNECTING DIAGRAM

SPEAKER (Left)

STEREO TUNER AMP

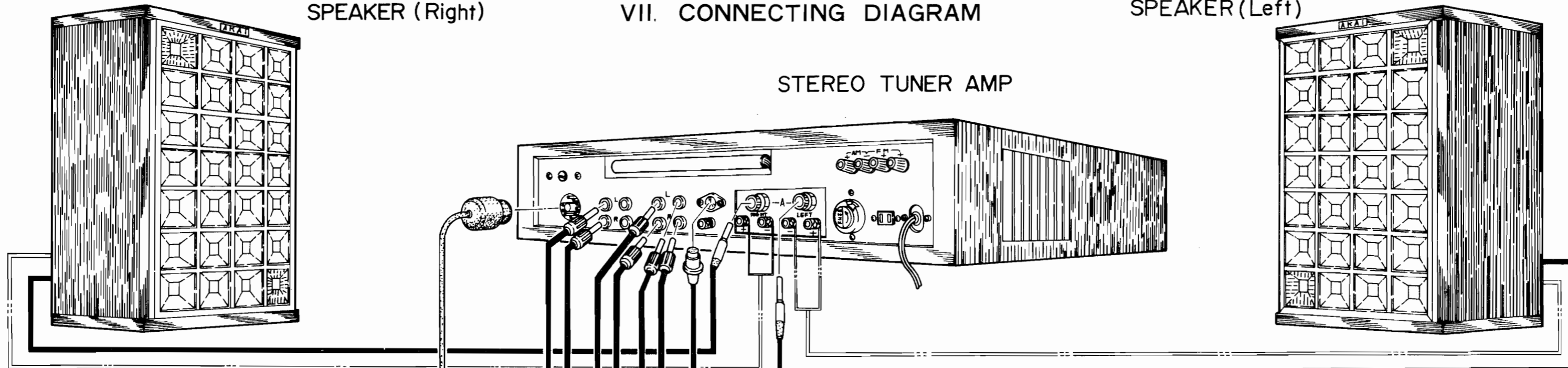

REMOTE CONTROL

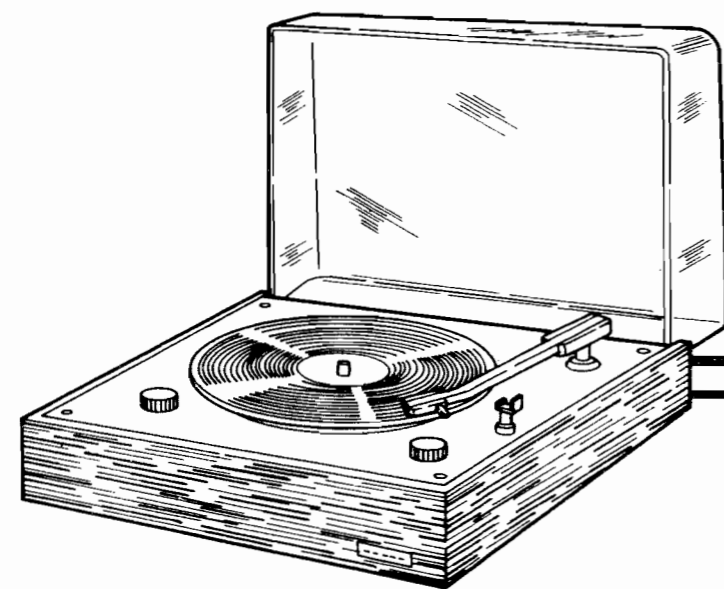
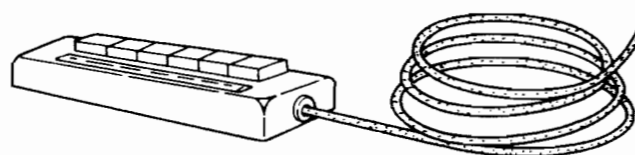

STEREO PLAYER

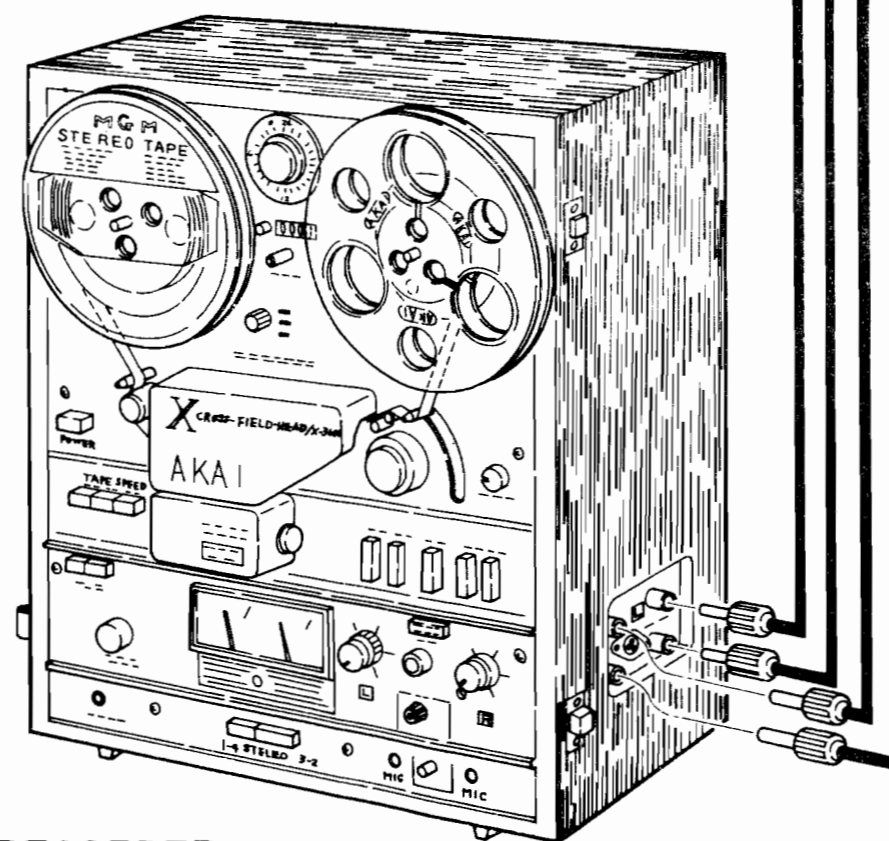

TAPE RECORDER

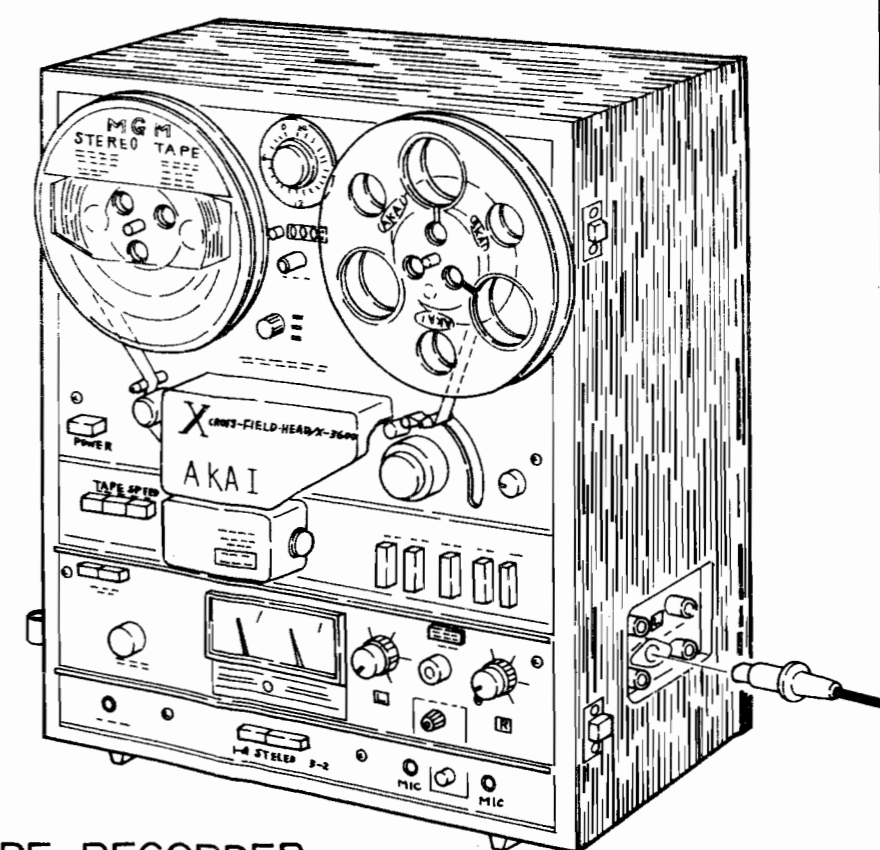

TAPE RECORDER

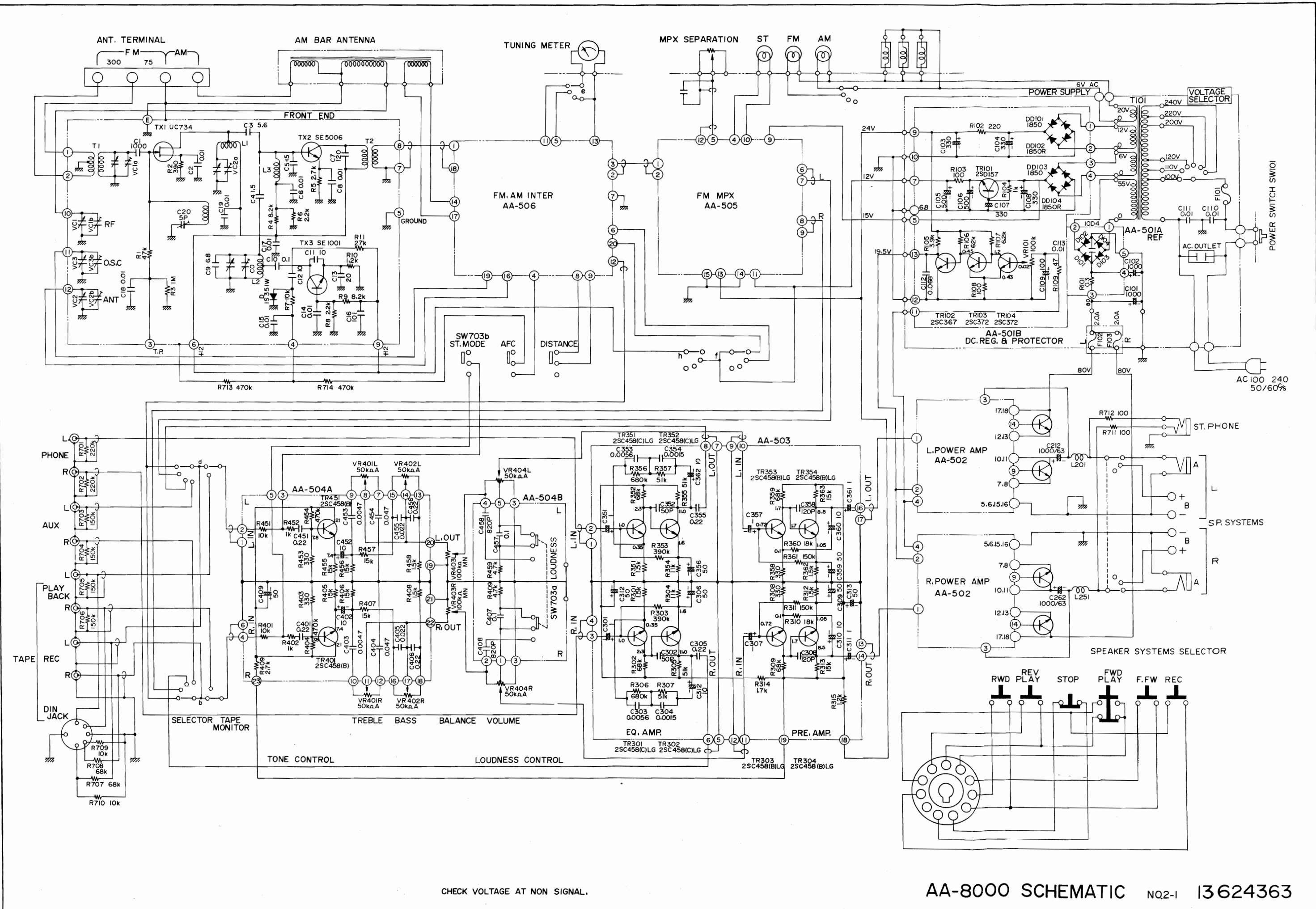

CHECK VOLTAGE AT NON SIGNAL.

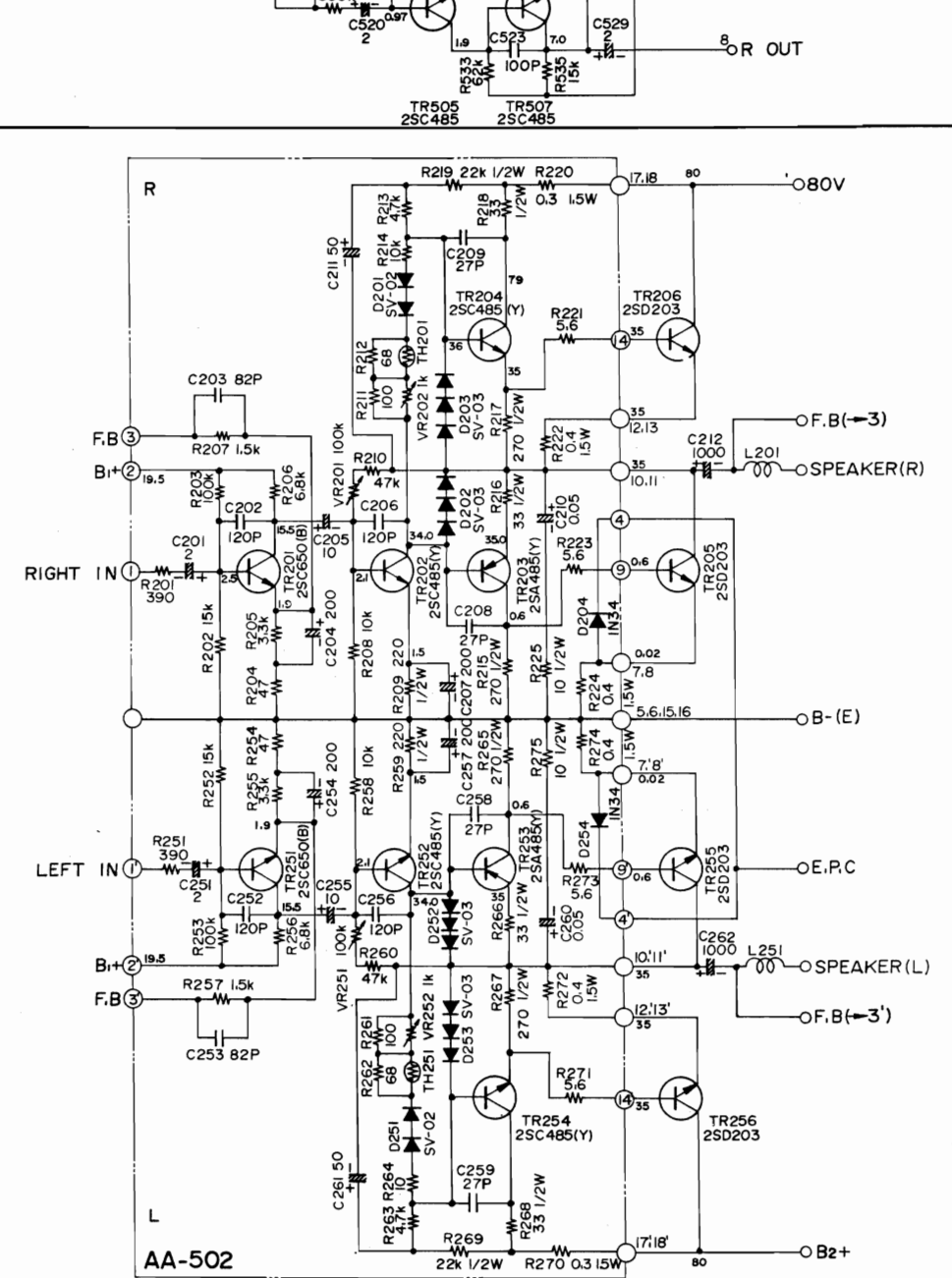
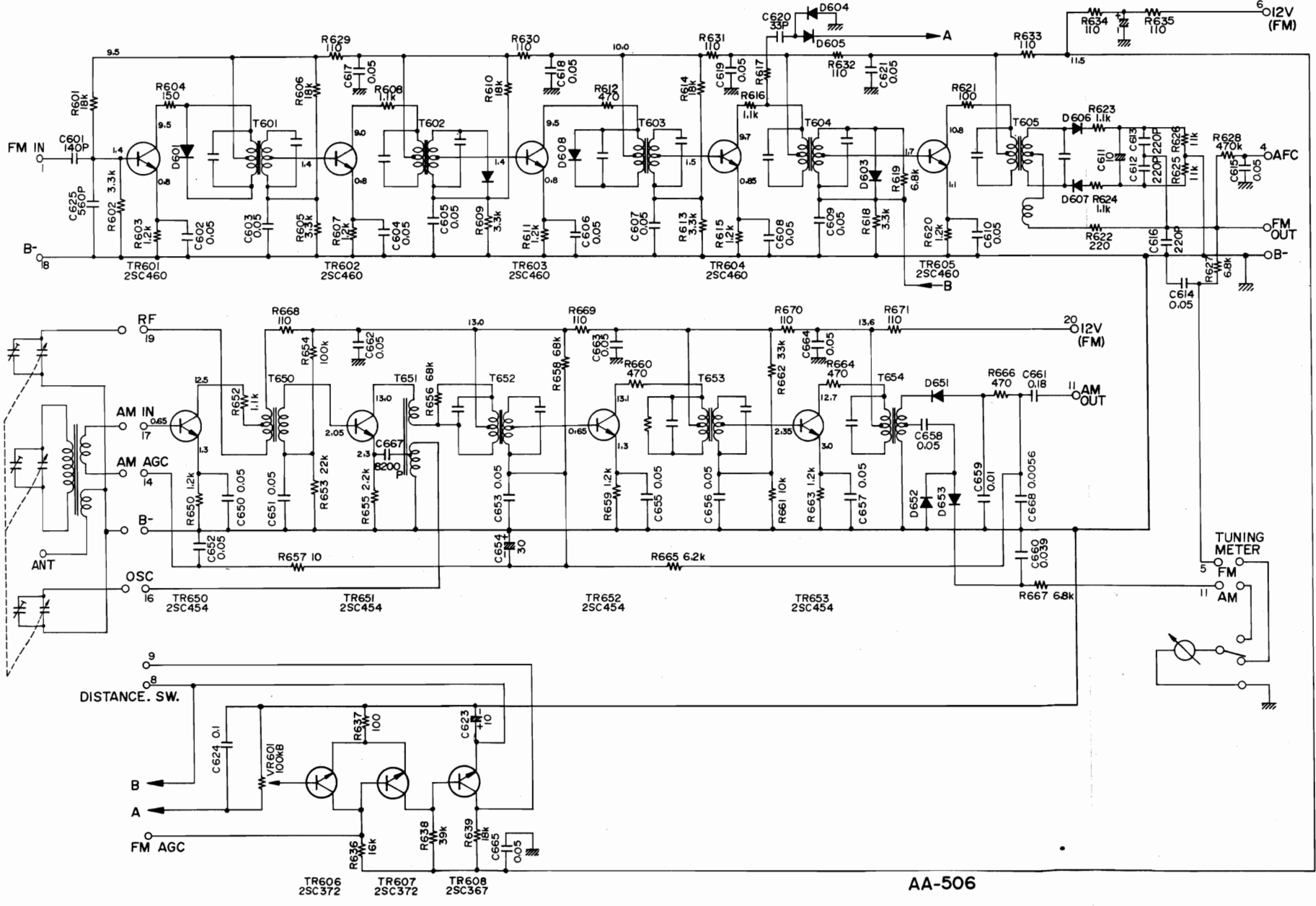
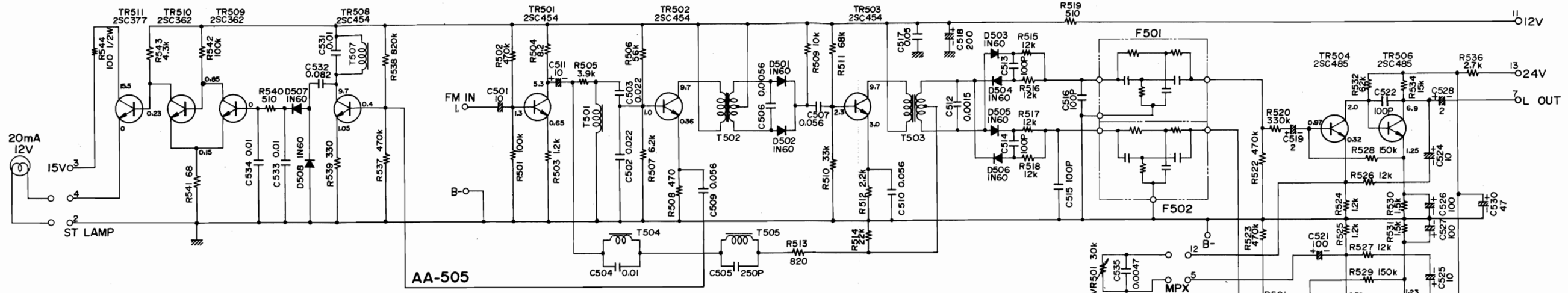

TERMINALS WITH MARK (NO 2-7-10-13-15-18) ARE B

\* R & L BOARDS (-AA-502) HAVE THE SAME ARTICLES ON IT THOUGH PARTS # ARE DIFFERENT  
 \* THE TERMINAL ON CIRCUIT ARE IDENTIFIED WITH CONNECTORS (CN201 AND CN251)

CHECK VOLTAGE AT NON SIGNAL,  
 AND DISTANCE SWITCH SHOULD BE "ON" IN FM CIRCUIT.

AA-502 POWER AMP, AA-505 FM-MPX, AA-506 INTER,

AA-8000 CARD SCHEMATIC NO2-2 13624383