

AA-A25/Y1  
AA-A25L

# AKAI SERVICE MANUAL

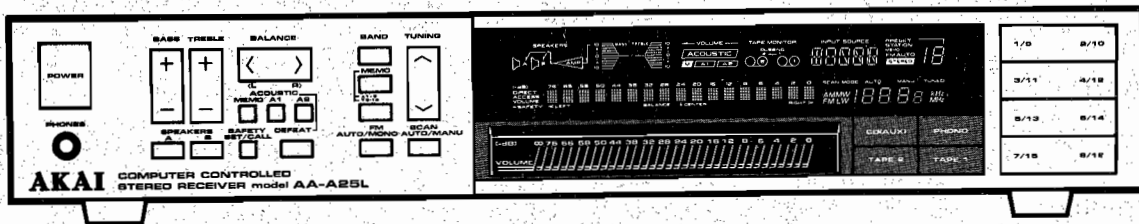

COMPUTER CONTROLLED STEREO RECEIVER

**AA-A25/Y1**  
**MODEL AA-A25L**

## ABBREVIATIONS FOR SERVICE MANUAL MODEL AA-A25/Y1, AA-A25L

ABBREVIATION	EXPLANATION	ABBREVIATION	EXPLANATION
AC	Alternating Current	LW	Long Wave
A/D	Analog/Digital	MOD	MODulation
AFC	Auto Frequency Control	MW	Middle Wave
AGC	Auto Gain Control	MPX	Multi PleX
ALC	Auto Level Control	OSC	OSCillator
AM	Amplitude Modulation	PB	Play Back
ANT	ANTenna	PLL	Phase Locked Loop
A-SW	Analog SWitch	REC	RECORD
BUF	BUFFer	RF	Radio Frequency
CK	ClOCK	RST	ReSeT
D/A	Digital/Analog	SEG	SEGment
DC	Direct Current	SENS	SENSitivity
DET	DETECTOR	SM	Signal Meter
FF	Flip Flop	SSG	Standard Signal Generator
FLD (FL DISPLAY)	FLuorescent Display	ST	STrob
FM	Frequency Modulation	SW	SWitch
FREQ	FREQUENCY	T.H.D	Total Harmonic Distortion
GND	GrouND	VCO	Voltage Controlled Oscillator
IF	Intermediate Frequency	VR	Variable Resistor

AA-A25/Y1  
AA-A25L

46 456



# SERVICE MANUAL

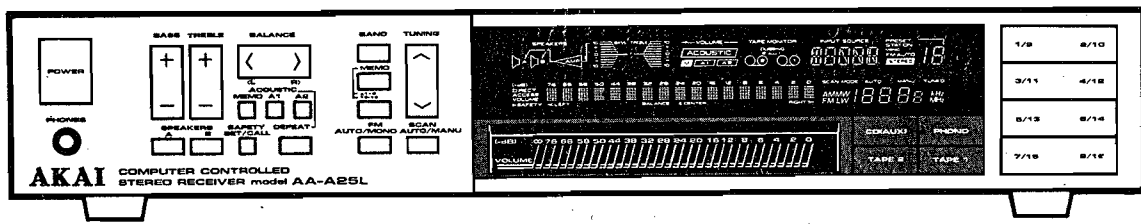

COMPUTER CONTROLLED STEREO RECEIVER

**AA-A25/Y1**  
**MODEL AA-A25L**



**COMPUTER CONTROLLED STEREO RECEIVER**

**AA-A25/Y1**

**MODEL AA-A25L**

<b>SECTION 1</b>	<b>SERVICE MANUAL .....</b>	<b>3</b>
<b>SECTION 2</b>	<b>PARTS LIST .....</b>	<b>19</b>



# SAFETY INSTRUCTIONS

## SAFETY CHECK AFTER SERVICING

Confirm the specified insulation resistance between power cord plug prongs and externally exposed parts of the set is greater than 10 Mohms, but for equipment with external antenna terminals (tuner, receiver, etc.) and is intended for [C] or [A], specified insulation resistance should be more than 2.2 Mohms (ground terminals, microphone jacks, headphone jacks, line-in-out jacks etc.)

## PRECAUTIONS DURING SERVICING

1. Parts identified by the  $\Delta$  symbol parts are critical for safety.  
Replace only with parts number specified.
2. In addition to safety, other parts and assemblies are specified for conformance with such regulations as those applying to spurious radiation. These must also be replaced only with specified replacements.  
Examples: RF converters, tuner units, antenna selector switches, RF cables, noise blocking capacitors, noise blocking filters, etc.
3. Use specified internal wiring. Note especially:
  - 1) Wires covered with PVC tubing
  - 2) Double insulated wires
  - 3) High voltage leads
4. Use specified insulating materials for hazardous live parts. Note especially:
  - 1) Insulation Tape
  - 2) PVC tubing
  - 3) Spacers (Insulating Barriers)
  - 4) Insulation sheets for transistors
  - 5) Plastic screws for fixing microswitch (especially in turntable)
5. When replacing AC primary side components (transformers, power cords, noise blocking capacitors, etc.), wrap ends of wires securely about the terminals before soldering.

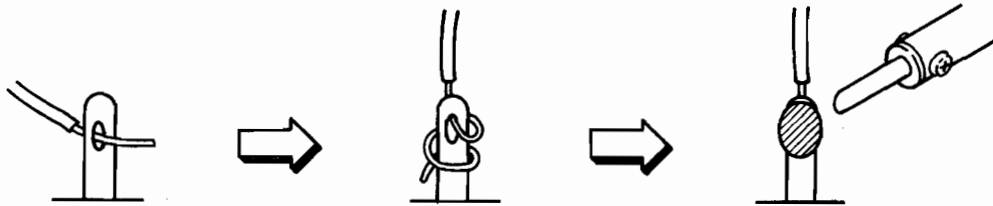

6. Observe that wires do not contact heat producing parts (heatsinks, oxide metal film resistors, fusible resistors, etc.).
7. Check that replaced wires do not contact sharp edged or pointed parts.
8. Also check areas surrounding repaired locations.
9. Use care that foreign objects (screws, solder droplets, etc.) do not remain inside the set.

## VOLTAGE CONVERSION

Models for Canada, USA, Europe, UK and Australia are not equipped with this facility. Each machine is preset at the factory according to destination, but some machines can be set to 110V, 120V, 220V or 240V as required. If your machine's voltage can be converted:

Before connecting the power cord, turn the VOLTAGE SELECTOR located on the rear panel with a screwdriver until the correct voltage is indicated.

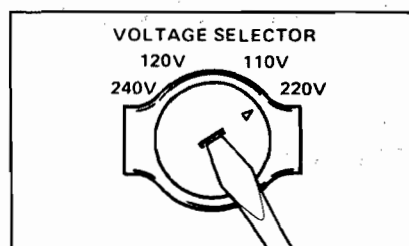

# I. SPECIFICATIONS

## FM TUNER SECTION

TUNING FREQUENCY RANGE	87.5MHz to 108.0MHz
USABLE SENSITIVITY (IHF)	11.2dBf (300 ohms)
QUIETING SENSITIVITY (IHF) (S/N = 50dB)	16.2dBf (Mono)/37.2dBf (Stereo)
CAPTURE RATIO	1.5dB
SELECTIVITY (IHF)	60dB (400kHz)
IMAGE REJECTION	85dB
IF REJECTION	90dB
SPURIOUS REJECTION	90dB
AM SUPPRESSION	60dB
S/N (IHF)	75dB (Mono)/65dB (Stereo)
HARMONIC DISTORTION	0.1% (Mono)/0.3% (Stereo)
STEREO SEPARATION	45dB (1kHz)

## LW TUNER SECTION (AA-A25L Only)

TUNING FREQUENCY RANGE	146kHz to 353kHz
USABLE SENSITIVITY (IHF)	800 $\mu$ V/m
SELECTIVITY (IHF)	30dB
IMAGE REJECTION	45dB
IF REJECTION	55dB
S/N	35dB
T.H.D.	2.0%
ANTENNA	Loop antenna

## AM TUNER SECTION (MW for AA-A25L)

TUNING FREQUENCY RANGE	530kHz to 1610kHz for USA and Canada 531kHz to 1602kHz for other countries
USABLE SENSITIVITY (IHF)	300 $\mu$ V/m
SELECTIVITY (IHF)	25dB
IMAGE REJECTION	40dB
IF REJECTION	55dB
S/N	40dB
T.H.D.	1.0%
ANTENNA	Loop antenna

## AMPLIFIER SECTION

RATED POWER OUTPUT		8 ohms 30WX2/0.05% 33WX2/0.05%
	20Hz to 20kHz 1kHz	
MUSIC POWER		60W
POWER BANDWIDTH (IHF, -3dB, 8ohms)		5Hz to 60kHz/0.1%
S/N	PHONO AUX	75dB 98dB
RESIDUAL NOISE (8 ohms)		0.5mV
CHANNEL SEPARATION (IHF)	PHONO/AUX	65dB (1kHz)
DAMPING FACTOR (1kHz, 8 ohms)		50
OUTPUT	SPEAKER	A or B 4 to 16 ohms A + B 8 to 16 ohms
INPUT SENSITIVITY/IMPEDANCE	PHONO AUX/TAPE	2.5mV/100kohms 150mV/47kohms
OUTPUT LEVEL/IMPEDANCE	TAPE REC	150mV/3kohms
FREQUENCY RESPONSE	PHONO (RIAA) AUX/TAPE	$\pm$ 0.5dB (30Hz to 15kHz) 5Hz to 100kHz -3dB
TONE CONTROL	BASS TREBLE	$\pm$ 8dB (100Hz) $\pm$ 8dB (10kHz)
PHONO MAX. INPUT (MM)		150mV (1kHz)
POWER REQUIREMENTS		120V, 60Hz for USA & Canada 220V, 50Hz for Europe except UK 240V, 50Hz for UK & Australia 110V/120V/220V/240V, 50/60Hz switchable for other countries
DIMENSIONS		440(W) x 80(H) x 318(D) mm
WEIGHT		6.2kg

\* For improvement purposes, specifications and design are subject to change without notice.



### III. CONTROLS

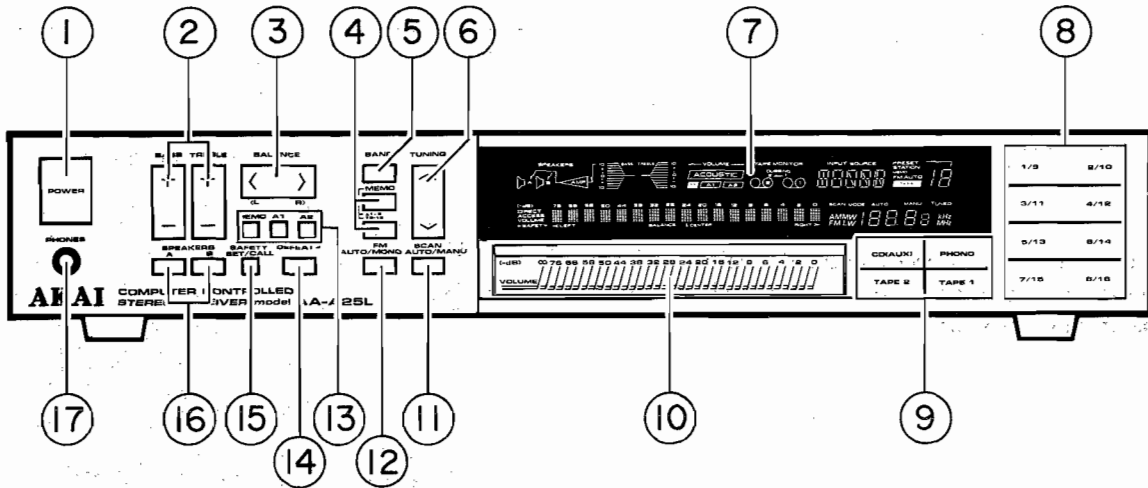

Fig. 3-1 Front View

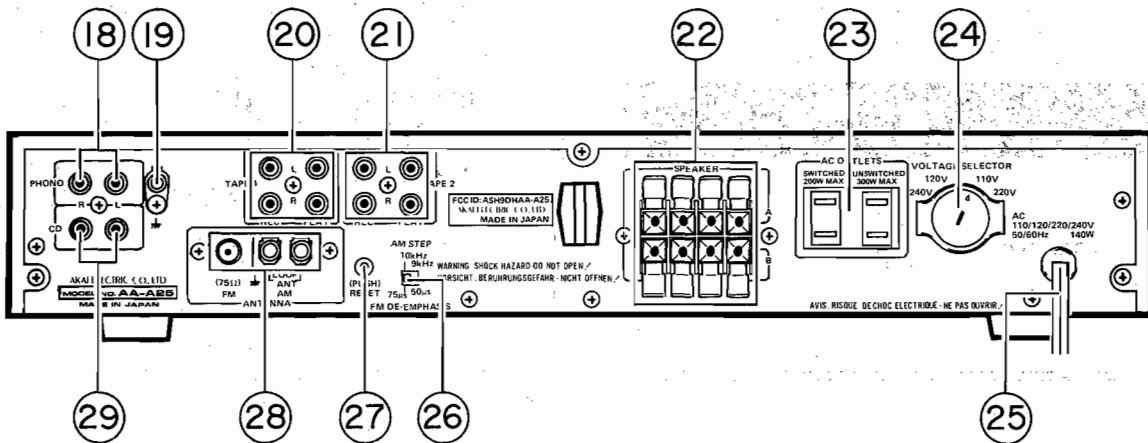
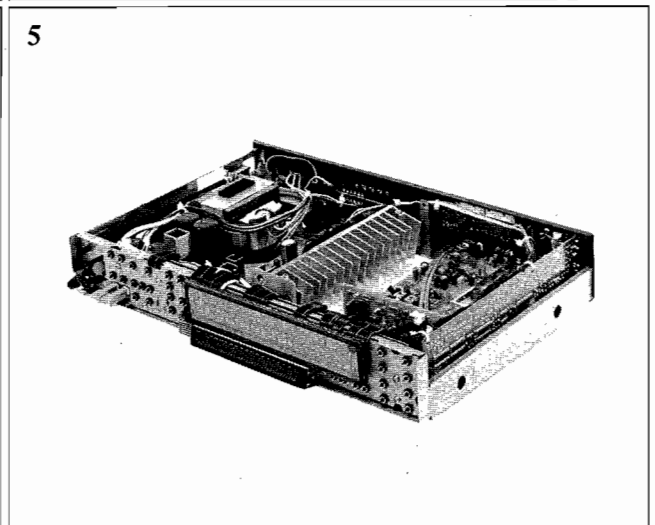
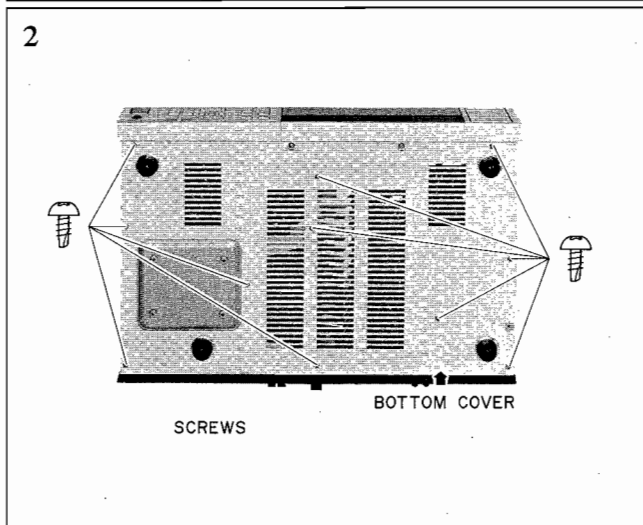
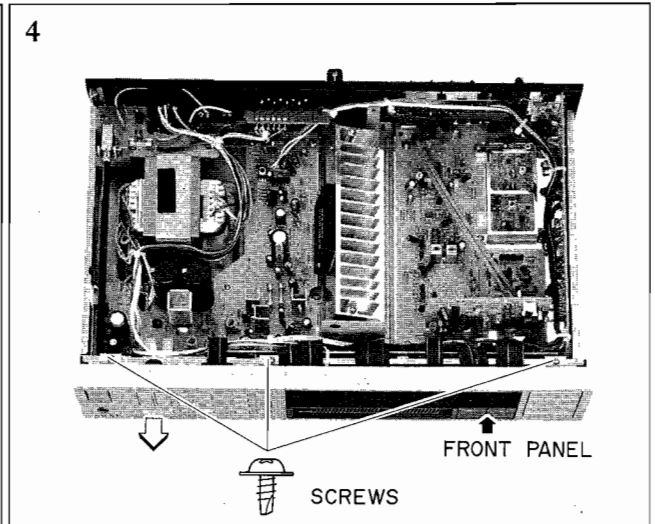
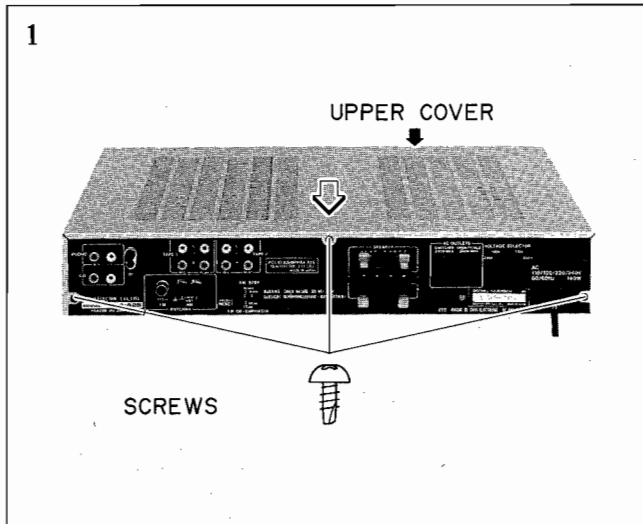

Fig. 3-2 Rear View

- |   |  |
|---|--|
| <ol style="list-style-type: none"> <li>1. POWER SWITCH</li> <li>2. TONE CONTROL (BASS, TREBLE) BUTTONS</li> <li>3. BALANCE BUTTON</li> <li>4. STATION MEMO BUTTONS (1 to 8 &amp; 9 to 16)</li> <li>5. BAND SELECTOR BUTTON</li> <li>6. TUNING CONTROL BUTTON</li> <li>7. FL DISPLAY</li> <li>8. PRESET STATION BUTTONS</li> <li>9. INPUT SOURCE SELECTORS BUTTON (PHONO, CD-(AUX), TAPE1 and TAPE2)</li> <li>10. DIRECT ACCESS VOLUME CONTROL</li> <li>11. SCAN AUTO/MANU SELECTOR BUTTON</li> <li>12. FM MODE AUTO/MONO BUTTON</li> <li>13. ACOUSTIC MEMO, A1 and A2 BUTTONS</li> <li>14. DEFEAT BUTTON</li> <li>15. SAFETY SET/CALL BUTTON</li> </ol> | <ol style="list-style-type: none"> <li>16. SPEAKERS SELECTOR (A and B) SWITCH</li> <li>17. PHONES JACK</li> <li>18. PHONO JACKS</li> <li>19. GROUND TERMINAL</li> <li>20. TAPE 1 (REC/PLAY) JACKS</li> <li>21. TAPE 2 (REC/PLAY) JACKS</li> <li>22. SPEAKER TERMINALS (A and B)</li> <li>23. AC OUTLETS</li> <li>24. VOLTAGE SELECTOR (U, Y<sub>1</sub> model only)</li> <li>25. AC POWER CORD</li> <li>26. AM STEP/FM DE-EMPHASIS SELECTOR (U, Y<sub>1</sub> model only)</li> <li>27. RESET BUTTON</li> <li>28. ANTENNA TERMINAL</li> <li>29. CD (AUX) JACKS</li> </ol> |
|---|--|

## II. DISMANTLING OF UNIT

In case of trouble, etc. necessitating dismantling, please dismantle in the order shown in the photographs. Reassemble in reverse order.



# V. DESCRIPTION OF THE CIRCUIT OPERATION

## 5-1 AMPLIFIER PERFORMANCE

### 5-1-1 General Description

#### (1) Functions

- a) **Input Selector Control**  
This microcomputer is capable of controlling analog switch TC9164N that serves as the input selector. Three input systems that include PHONO, CD, and TUNER, and two monitoring systems that include TAPE 1 and TAPE 2 may be controlled.
- b) **Direct Access Volume Control**  
Reads voltages detected out of the sound-volume touch control through an A/D converter, and sets the electronic potentiometer in accordance with the read data. In this process, any designated setting will be reached from the earlier potentiometer position by fading in or out.
- c) **Balance Control**  
By setting various level differences between Lch and Rch on the main control, up to a maximum of 30dB L-R level offsets may be created.
- d) **Tone (BASS/TREBLE) Control**  
Operates the tone control potentiometer (TC9156P) in 2dB steps up to a maximum of  $\pm 10$ dB, and thereby performs as an electronically controlled tone circuit.
- f) **Acoustic Pattern Storage**  
By this function, stores in the microcomputer two patterns of the tone control circuit settings, and enables the instant loading of either of the stored patterns.
- g) **Volume Control Safety Function**  
With the touch control operated direct access sound volume system that enables the instant setting of any preferred sound volume level, the danger exists that the inadvertent touch of a higher position of the control will cause a sudden emission of unexpectedly high sounds from speakers. A time lag measure in the form of fade-in's has been provided to enable coping with the above danger, but as an added and positive precaution, this safety function has been added on that suppresses all sounds louder than a level set in advance.
- h) **TUNER Direct Function**  
This function will set the input selector at TUNER upon receiving data from the microcomputer (A1007T) for the tuner that is output as soon as the tuner has been operated.

### 5-1-2 Key Input and Dynamic FL Display Strokes

Key inputs and FL displays are both handled dynamically, and their basic clock signals generated by the ITMR interrupt (1,024 Hz) for the output of strobe signals.

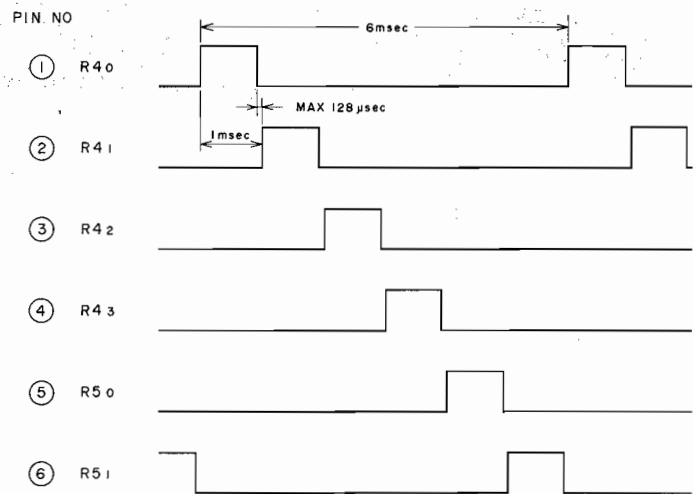

Fig. 5-1

### 5-1-3 Acceptance of Key Inputs

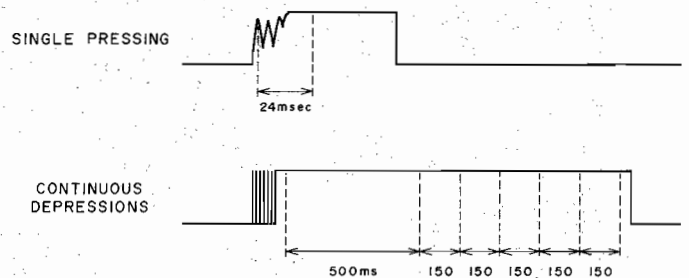

Fig. 5-2

- Chatterings will be absorbed for 24 msec.
- Continuous depressions will be accepted first at 24 msec after the depression start, second at 500 msec after the first, and then at every 150 msec thereafter.
- All multiple depressions shall be inhibited. Once a multiple depression is made, no key inputs will be accepted until after all of the depressed keys have been released.

### 5-1-4 Key Processings

#### (1) [PHONO], [CD]

Sets the input selector (TC9164N) for either of the input modes keyed in, and makes due indications for it. Nothing, however, will occur when the depressed key mode has already been engaged.

When either TAPE 1 or TAPE 2 has been keyed on, the displays for a tape monitored input will be flashed on and off for 10 times at a 1/2 duty and once every second, to alert the operator of the ongoing tape monitoring. In addition, when serial data is being transferred to the analog switch, the

# IV. PRINCIPAL PARTS LOCATION

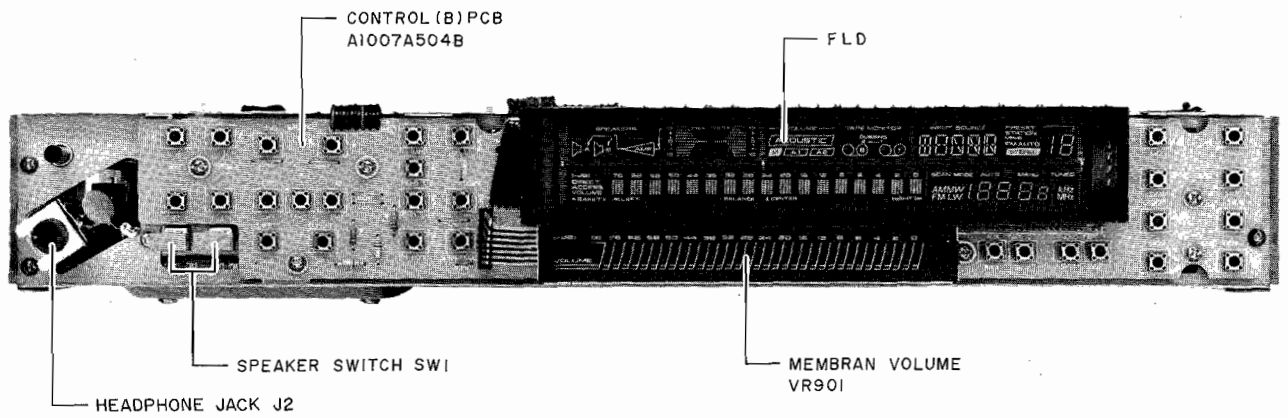

Fig. 4-1 Front View

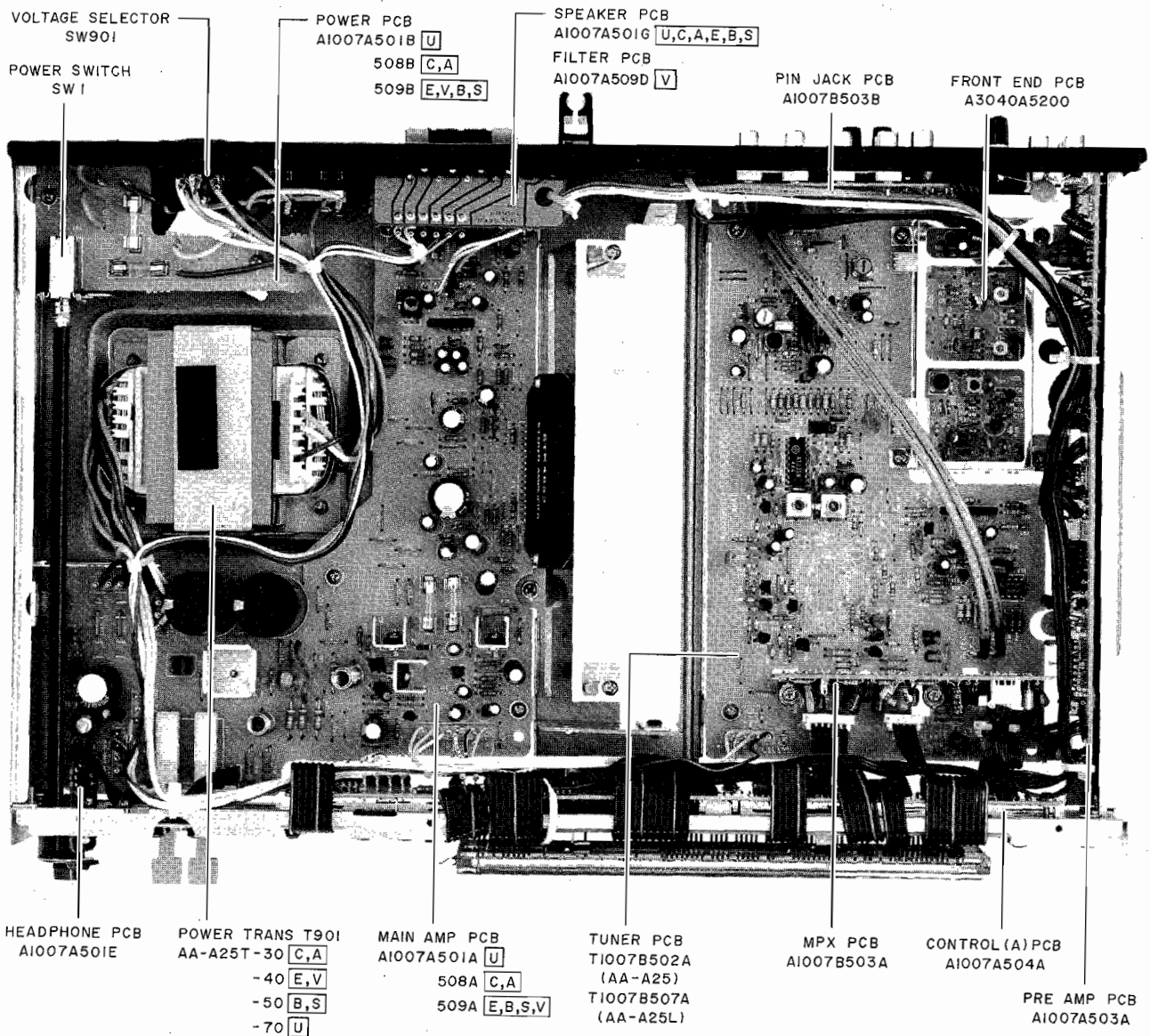

Fig. 4-2 Upper View



### 5-1-5 Input Selector Analog Switch (TC9164N)

Controls the electronic potentiometer (TC9176P) and the tone potentiometer (TC9156P).

#### (1) Serial Data Structure

The serial data is composed of 3 parallel bits that include DATA, CK, and ST, and the numbers of serial bits of the individual potentiometers have been made as follows:

- TC9164N → 14 bits
- TC9176P → 20 bits
- TC9156P → 18 bits

Control lines DATA and CK for the TC9176P and TC9156P have been made common with control lines ST-WR and CE for A/D converter LC7910, because A/D conversion and data transfers to the potentiometers will never occur simultaneously, and no changes in the status of potentiometers will take place as long as no ST are issued.

[Data Timing Schematic Diagram]

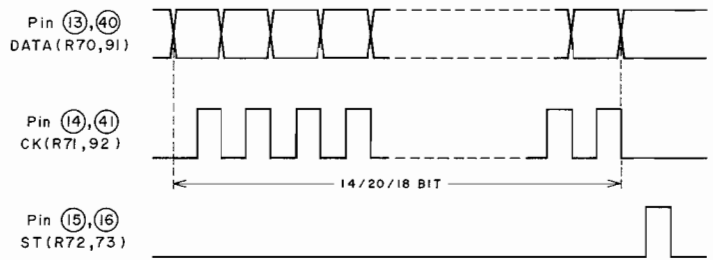

Fig. 5-3

#### (2) Data Buffers

Data buffers for the TC9146N are formed in RAMs MFSRD0 through MFSRD3, and those for the TC9176P and TC9156P in RAMs MVSRD0 through MVSRD4. Their allocation charts are shown in Tables 5-1 to 5-3.

#### a) Buffers for the Input Selector Switch (TC9164N)

MFSRD3				MFSRD2				MFSRD1		MFSRD0			
Unused	PHONO	CD	TUNER	SOURCE 1	TAPE1 P.B.	SOURCE 2	TAPE2 P.B.	L	R	C <sub>1</sub>	C <sub>2</sub>	C <sub>3</sub>	C <sub>4</sub>
0				0	1	1	0	1	1	0	1	0	0

→ Fixed Data

ON      OFF

Table 5-1

Bits 2 and 3 of MFSRD1 will not be transmitted.

#### b) Buffers for the Master Potentiometer (TC9176P)

MVSRD4			MVSRD3				MVSRD2				MVSRD1				MVSRD0			
L	R	0	2	4	6	8	0	10	20	30	40	50	60	70	C <sub>1</sub>	C <sub>2</sub>	C <sub>3</sub>	C <sub>4</sub>
		0													0	0	0	1

→ Fixed Data

Table 5-2

#### c) Buffers for the Tone Potentiometer (TC9156P)

MVSRD4				MVSRD3		MVSRD2				MVSRD1		MVSRD0				
+5	+4	+3	+2	+1	0	1	-2	-3	-4	-5	L	R	C <sub>1</sub>	C <sub>2</sub>	C <sub>3</sub>	
				0	0					1			1	0	1	0
				0	0					1			1	1	0	0

→ For BASS

→ For TREBLE

Table 5-3

electronic potentiometer will be muted, to prevent the leakage of switching noises to the output circuit. (The AA-A25/L has no "TUBER" key, but the necessary input selection will be made by command data from the micro-computer (A1007T) incorporated in the tuner.)

(2) [TAPE 1], [TAPE 2]

Each single pressing of either key will switch its monitoring status between ON and OFF from one to the other, and its indication also turn ON and OFF accordingly. In addition, during the transfer of serial data to the analog switch, the electronic potentiometer will be muted to prevent the leakage of switching noises to the output.

This, however, does not apply to TAPE 1 key operations with TAPE 2 in an ON mode.

(3) [VOLUME]

When the sound volume display is being made, either fades the sound volume display is being made, either fades in or fades out to the touched position from an immediately preceding level. The phasing speed will be 2 dB per 60 msec. However, when the touched position is above the "Safety" engaged position, the foregoing operation will be made only up to that "Safety" position. As for the display, the touched position (within the "Safety" range) will instantantly be displayed upon touching.

When either the Balance or the Safety Level is being displayed, the display will be switched to the Volume. Operations thereafter will conform with the above process.

(4) [BALANCE L], [BALANCE R]

When the Balance is being displayed, data will be transferred to provide the designated level offsets between Lch and Rch of the electronic potentiometer, and the display will also synchronize therewith. When continuously depressed, however, the potentiometer setting will start varying at 500 msec after the depression start, and will thereafter vary at 2 dB per 150 msec, but linger for 750 msec at the center position when passing through it. (The display will vary at 2 dB per step in the immediate vicinity of the center position, but at 4 dB per step in all other areas.)

When these keys are pushed while either the Volume or the Safety Level is being displayed, the display will be switched to the Balance.

(5) [SAFETY]

- When either the Volume or Balance position is being displayed:

A single press of the key will first have the Safety Level position at the time displayed. This display will revert to the Volume position display 5 seconds later, but if the Safety key is depressed continuously for one second or longer, the display will be switched to that of the Volume, and the

Safety indicator will flash on and off every second at a 1/2 duty. This signifies a Safety changing mode to have been engaged, where any Volume level up to Max may be selected, and the mode will be sustained for one minute. In other words, the one minute after the beginning of the Safety flashing represents a Safety Level setting time duration.

- When the Safety indicator is flashing on and off: The Volume position touched in this duration will be set as the Safety Level that represents the sound volume level not be exceeded by any subsequent acoustic output. As long as the Safety Level set is other than the maximum potentiometer position, the Safety indicator will be lit steadily, but when it is at the maximum position, the indicator will go off.

(6) [BASS+], [BASS-], [TREBLE+], [TREBLE-]

Each single pressing of one of these keys will either raise or lower the electronic potentiometer for either BASS or TREBLE. When it is depressed continuously, the first potentiometer up/down shifting operation will be performed when 500 msec have elapsed since the depression start, and the subsequent operation at the rate of 150 msec per step. When the shifting passes through the center position, it will linger there for 750 msec before moving further on. The display will also vary conforming with individual key operations.

(7) [DEFEAT]

Restores the BASS/TREBLE positions all at the center, regardless of their earlier potentiometer positionings.

(8) [MEMO]

Engages an acoustic pattern storage standby mode. At this time, the ACOUSTIC MEMO indicator will turn on, and the A1 and A2 indicators flash on and off for 10 times at a 1/2 duty in 1-second cycles (at 1 Hz).

Even before 5 seconds are up, the standby mode may be disengaged by pushing any other key than [A1] and [A2].

(9) [A1], [A2]

- When at Standby for Acoustic Pattern Storage: Stores the current BASS/TREBLE positions in the memory, and will disengage the storage standby mode.
- When in any other mode than Acoustic Pattern Storage Standby: Loads the stored BASS/TREBLE positions, that is, sets the potentiometers instantly at those positions and their displays at the same time.

## (2) Non-Active Mode

This is a mode where the tuner performance has been partially constrained. It is engaged by detecting an [H] level of the line connected to R7<sub>2</sub> (A1007T Pin 15) of the subject microcomputer, which has been brought about by the microcomputer of AMP in switching the input selector of AMP to other than TUNER, either PHONO or CD, and by judging the tuner thereby not to be listened to.

Relative to the display, the frequency display will be extinguished, and bars displayed instead, to signify a non-active mode.

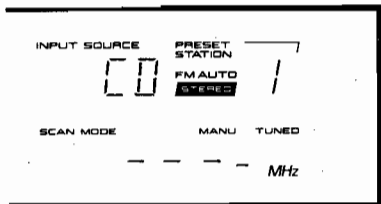

Fig. 5-7

Relative to the operating performance, will accept only the BAND, UP/DOWN, and Preset CH keys, and reject all the other keys.

## 5-2-6 Auto-Tuning

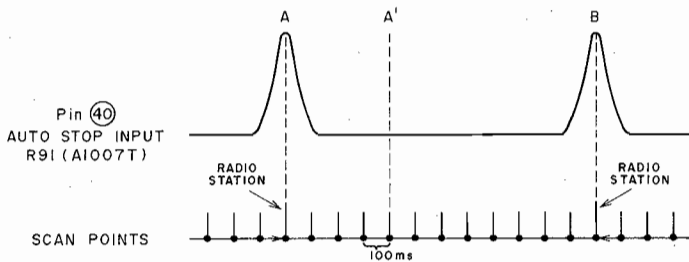

Fig. 5-8

The starting point in auto tuning modes may either be a broadcast receiving point or a point where no broadcast is received.

Since stopping the scan merely at an [H] level of the auto-stop signal may therefore cause nonconformities, the process employed is to stop scanning only when the auto-stop signal has first dropped to an [L] level after the scanning start and then has climbed to an [H] level.

The scanning speed is about 100 msec per step. The step will be a single channel spacing in the receiving band that varies by destination. Auto-scanning of LW, however, is an exception to this rule and 9 kHz steps have been assigned to it, where fixed points  $9N+2$  or  $9N$  ( $N = \text{an integer}$ ) will be scanned.

In other words, against any given point selected earlier by a manual scan, the scanning start when an auto-scanning mode is engaged will always be at a point  $9N+2$  or  $9N$ .

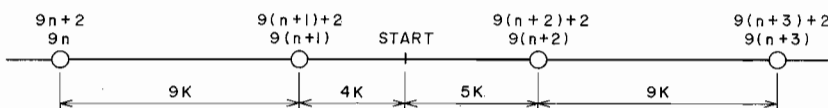

Fig. 5-9

## 5-2-7 Tuner Output Muting

This microcomputer will mute the tuner signal when the BAND data or PLL data is changed by the [BAND], [UP], [DOWN], [MODE], or Preset CH key, or when the receiving-mode is changed.

In the muting process, when 50 msec have elapsed since the initial muting start, data transfer and other processings will be made, and then, 450 msec after these processes have been concluded, the muting will be disengaged. We will call the initial part "pre-muting" and the latter trailing part "after-muting".

The diagram below illustrates the above arrangement.

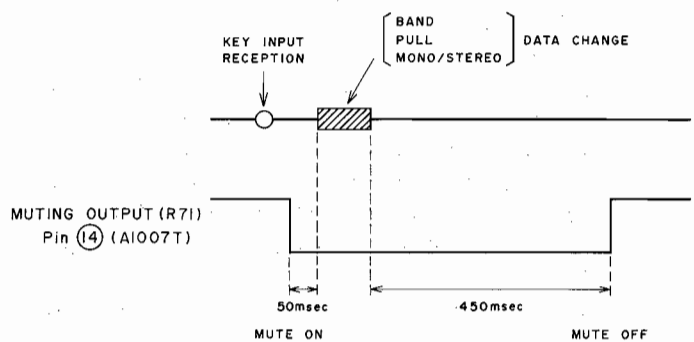

Fig. 5-10

As exceptional cases, when an earlier muting process is still ongoing upon receipt of another key input, the 50 msec pre-muting will be omitted.

## 5-2-8 Key Processing

### (1) [BAND]

Each single press of this key will switch the band. The selecting sequences will be as follows:

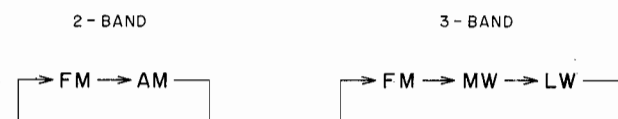

Fig. 5-11

### (2) [UP], [DOWN]

In a manual scan mode, each single pressing of either of these keys will shift the receiving frequency by a step, and its continuous depression will have the band scanned at 50 msec per step. In a AUTO scan mode, the band will be scanned at 100 msec per step until a station is captured, at which time an auto-stop of the scanning will be exercised. In an auto-scan mode, as soon as any other key than [UP] and [DOWN] is pushed, the scanning will be stopped at that point.

## 5-2 TUNER PERFORMANCE

### 5-2-1 General Description

#### (1) Functions

- a) 20-Ch or 16-Ch Random Presetting of Stations  
When initialized, discriminates between A45 and A35/25, and against A45, enables 10 stations each front (1 to 10) and back (11 to 20) or a total of 20 stations to be preset, while against A35/25, enables 8 stations each front (1 to 8) and back (9 to 16) or a total of 16 stations to be preset. The presetting permits the random storage of station data irrespective of band, and for FM stations, the MONO/STEREO segregating data will also be contained in the storage.
- b) Two Tuning Styles: AUTO and MANUAL  
The AUTO Scan Tuning that once the UP/DOWN key is pushed, will continue scanning until a station is captured, and once it is captured, will stop scanning, and the MANUAL Tuning that will scan only when the key is held down, and when it is released, will stop scanning, are the two tuning styles enabled.  
(LW is shifted in 1K steps for MANUAL and 9K steps for AUTO.)
- c) Switching of MONO and STEREO Receiving Modes  
The MONO/STEREO mode switching function has been incorporated for FM reception, and is also included in the stored station presetting data.

### 5-2-2 Acceptance of Key Input

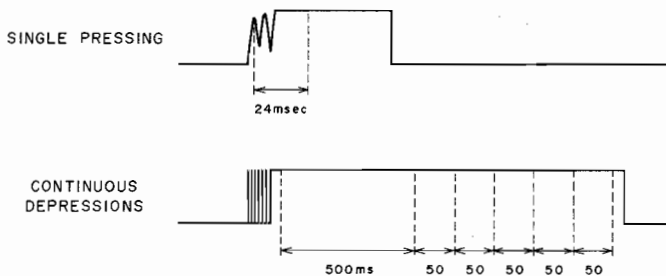

Fig. 5-4

- Chatterings will be absorbed for 24 msec.
- Continuous depressions will be accepted first at 24 msec after the depression start, second at 500 msec after the first, and then at every 50 msec thereafter.
- All multiple depressions shall be inhibited. Once a multiple depression is made, no key inputs will be accepted until after all of the depressed keys have been released.

### 5-2-3 Initial Setting (RST Mode)

- a) FL Display:

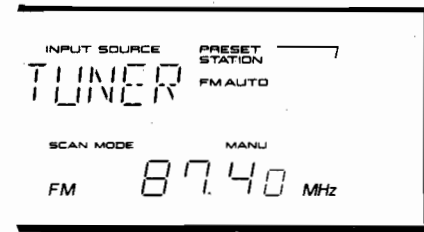

Fig. 5-5

- b) The received frequency will be at the lowest in the FM band for each destination:
- c) The mode will be STEREO (FM AUTO).
- d) The scan mode will be MANUAL.
- e) All the preset channels will be at the lowest FM frequency.
- f) The last frequencies of individual bands of the tuner will be the lowest frequencies.

### 5-2-4 Status in a Backup Mode

Basically, the status immediately before engaging the backup will all be sustained, but slight deviations will be involved, as listed below.

- a) When a backup mode is engaged during AUTO SCAN, the scanning will stop.
- b) When a backup mode is engaged in a storage standby mode, the standby will be disengaged.
- c) The pre-backup status will be sustained for about 3 weeks.

### 5-2-5 Active and Non-Active Modes at Tuner

#### (1) Active Mode

This is a mode after the data has been transmitted to the microcomputer (A1007A) of AMP to have the input selector of AMP switched to TUNER, that is, a mode where all the tuner performance has been enabled.

The data for the microcomputer of AMP will be transmitted from port R4<sub>1</sub> (A1007T Pin 2) when the BAND, UP/DOWN, and Preset CH keys have been pushed, and its timing will be as illustrated below.

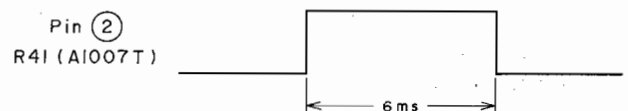

Fig. 5-6

# IV. TUNER ADJUSTMENT

## 6-1 THE INSTRUMENT CONNECTIONS

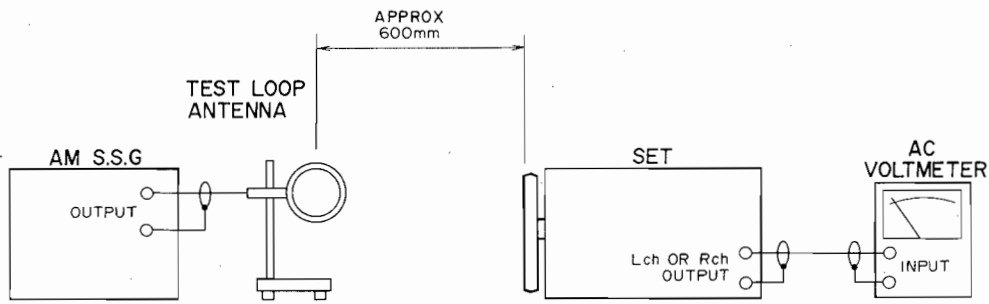

Fig. 6-1 Instrument Connections for AM (MW, LW) Section Adjustment

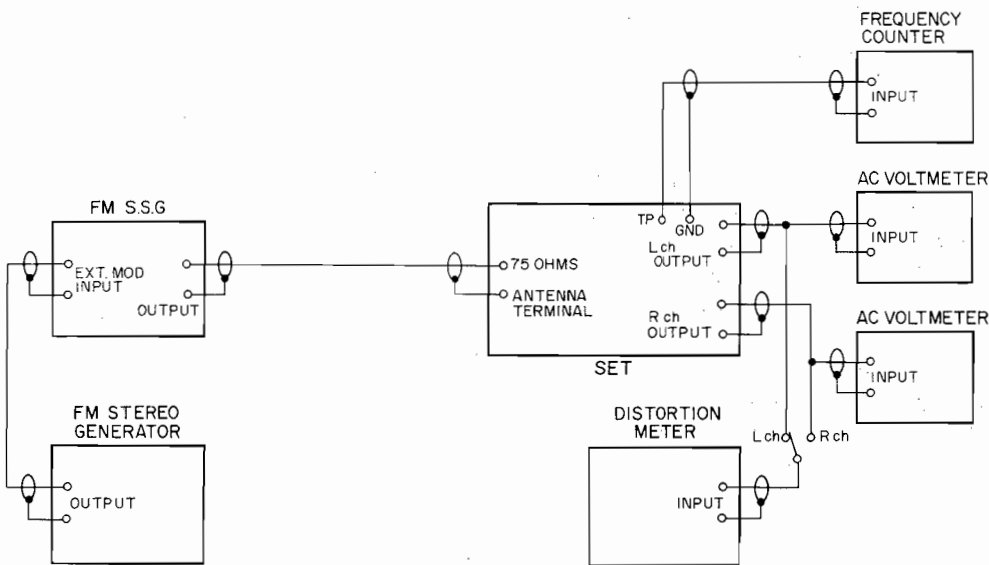

Fig. 6-2 Instrument Connections for FM Section Adjustment

## 6-2 TUNER, FRONT END, MPX PC BOARD ADJUSTMENT POINTS

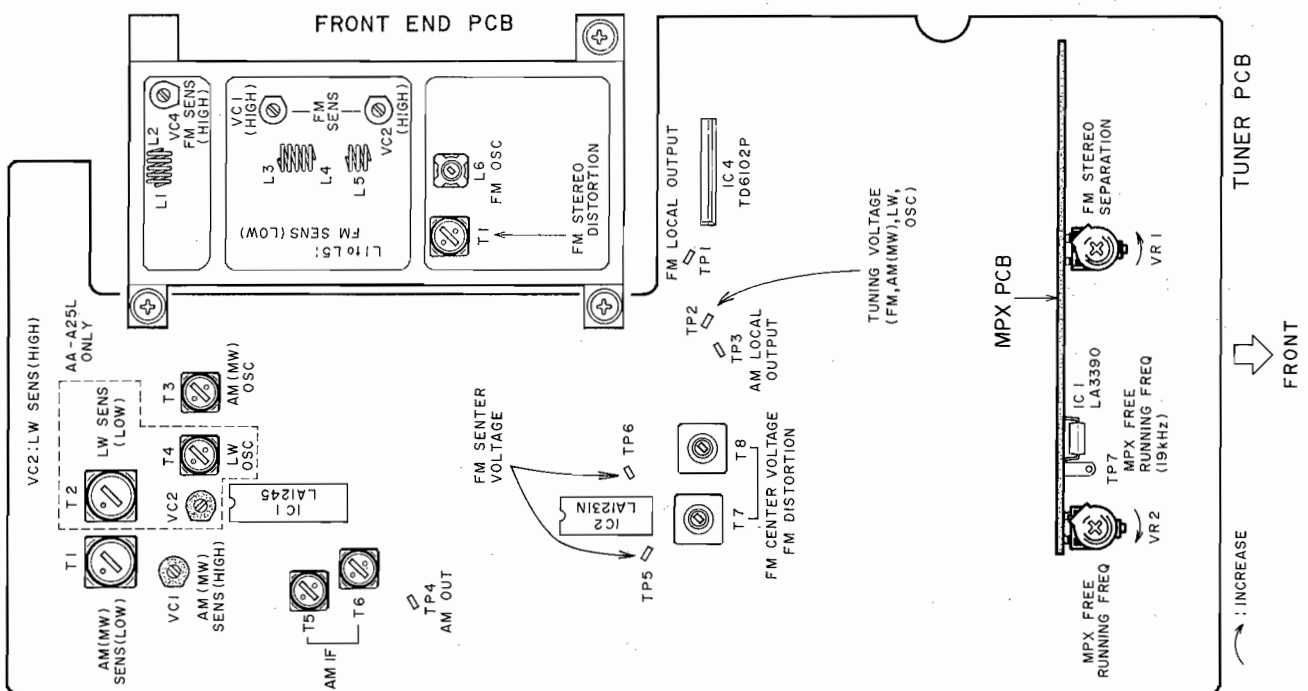

Fig. 6-3

**(3) Preset CH Key**

a) When the Tuner is in an Active Mode:

Except when at standby for storage, a single pressing of one of the preset channel keys will load the front (1 to 8) and back (9 to 16) side channels under that key alternately, and the FLD will display the number of the channel thus loaded.

When at standby for storage, the frequency currently being received will be stored in either the front (1 to 8) or back (9 to 16) side memory until under the key that has been pushed, and the storage standby mode will then be disengaged.

b) When the Tuner is in a Non-Active Mode:

A push of one of the keys will have the front side preset channel (1 to 8) under that key loaded, and have data transmitted to the microcomputer of AMP to switch the input selector of AMP to TUNER.

However, when in the last active mode of the tuner, a back side (9 to 16) channel had been listened to, and that channel key is now pushed, the loading effected will not be that of the front side (1 to 8) but of the back side (9 to 16) channel.

**(4) [MEMO 1 – 8], [MEMO 9 – 16]**

These are the keys for storing a channel frequency data in the Preset CH, and used for channels 1 to 8 and 9 to 16, respectively. Specifically, when either of the keys is pushed, the MEMO Indicator will be lit, and the channel number display flashed on and off, to alert the operator as to which side of the Preset CH key, 1 to 8 or 9 to 16, is being operated.

For 1 to 8:



For 9 to 16:

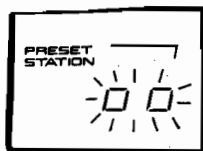

Fig. 5-12

The above mode will be sustained for 5 seconds, and the flashing repeated for 10 times at a 1/2 duty. When, however, the Preset CH key is pushed for data storage, or when any other key is pushed, the storage standby mode will be instantly disengaged.

When the tuner is in a non-active mode, nothing will occur.

**(5) [MODE]**

Each single pressing of this key will switch the FM reception between MONO and STEREO from one to the other.

When the tuner is in a non-active mode, nothing will occur.

**(6) [SCAN MODE]**

Each single pressing of this key will switch the scan mode between AUTO and MANUAL from one to the other, and due indications made at the same time.

## 6-4 FM SECTION ADJUSTMENT

Step	Adjustment Item	Adjustment Point	Result	Remarks
1	FM OSC	L6 (in FRONT END PCB)	12V at 108.1MHz	Band SW to FM 108.1MHz Mono input. Display to 108.1MHz. Connect DC Voltmeter to TP2.
2	Low Range Sensitivity	L1 to L5 (in FRONT END PCB)	Less than 10dB input from SSG	FM mode SW to Mono 90MHz, Mono input. Display to 90MHz. 3% Distortion Factor.
3	High Range Sensitivity	VC1, 2, 4 (in FRONT END PCB)	Less than 10dB input from SSG	106MHz, Mono input. Display to 106MHz. 3% Distortion Factor.
4	For best Result, Repeat Steps 2 and 3 two or three times			
5	Middle Range Sensitivity (Confirmation)	None	Less than 10dB input from SSG	98MHz, Mono input. Display to 98MHz. 3% Distortion Factor.
6	FM Center Voltage	T7, T8	0V indication	DC Voltmeter between TP5 and TP6. Tune only noise without interference from broadcasting.
7	Distortion (Mono)	T7, T8	Less than 0.3%	98MHz, 60dB, Mono input. Display to 98MHz. Confirm that the DC Voltage between TP5 and TP6 is within $0 \pm 0.025V$ .
8	MPX Free Running Frequency	VR2 (in MPX PCB)	19kHz	98MHz, 60dB Stereo input. Display to 98MHz. Connect Frequency Counter to TP7 (in MPX PCB).
9	Stereo Separation	VR1 (in MPX PCB)	More than 38dB	98MHz, 60dB, Stereo L-CH (R-CH) input: Display to 98MHz. Minimum output of R-CH (L-CH)
10	Distortion (Stereo)	T1 (in FRONT END PCB), T7, T8	Less than 0.5%	98MHz, 60dB Stereo (L-CH or R-CH) input. Display to 98MHz. Confirm that the DC voltage between TP5 and TP6 within $0 \pm 0.025V$ .

- NOTES:**
1. Set the internal modulation signal generator to 100% (75kHz dev. (in Europe) 40kHz dev.), 1kHz of each.
  2. Adjust T1 (Front End), if the proper distortion (STEREO) could not obtained in step 10. (Confirm FM Sensitivity in case is turned more than a half turn).



### 6-3 HOW TO CALL THE PRESET FREQUENCY FOR THE TUNER ADJUSTMENT

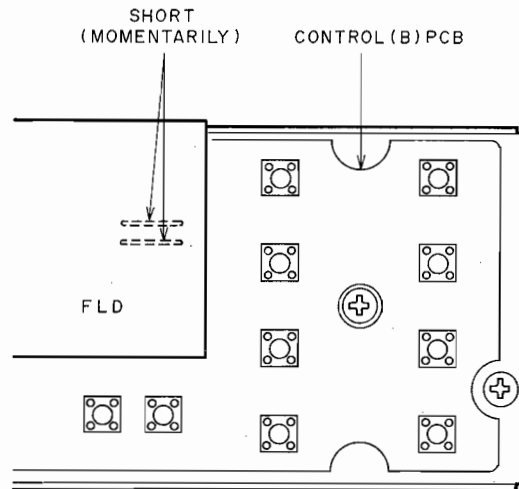

Fig. 6-4

Tuner preset frequencies for adjusting RF, IF and FM demodulator are able to preset as follows instead of operating TUNING control button to get the test frequencies from Signal Generator.

Short-circuit momentarily two test points shown in Fig. 6-4. Then select required test frequency by pushing one of the Preset Station buttons according to Chart 6-1.

	PRESET STATION CH								
	Buttons CH	1/9	2/10	3/11	4/12	5/13	6/14	7/15	8/16
USA & CANADA	1 to 8	AM 600kHz	AM 1000kHz	AM 1400kHz	FM 88.0MHz	FM 90.0MHz	FM 98.0MHz	FM 105.0MHz	FM 108.0MHz
	9 to 16	AM 530kHz	AM 1000kHz	AM 1611kHz	FM 87.4MHz	FM 90.0MHz	* FM 98.0MHz	FM 106.0MHz	FM 108.1MHz
EUROPE 3 BAND	1 to 8	MW 603kHz	MW 999kHz	MW 1404kHz	FM 88.0MHz	FM 90.0MHz	FM 98.0MHz	FM 106.0MHz	FM 108.0MHz
	9 to 16	MW 522kHz	MW 999kHz	MW 1611kHz	LW 146kHz	LW 160kHz	LW 200kHz	LW 300kHz	LW 353kHz
EUROPE 2 BAND UNIVERSAL AREA	1 to 8	AM 603kHz	AM 999kHz	AM 1404kHz	FM 88.0MHz	FM 90.0MHz	FM 98.0MHz	FM 106.0MHz	FM 108.0MHz
	9 to 16	AM 522kHz	AM 999kHz	AM 1611kHz	FM 87.4MHz	FM 90.0MHz	* FM 98.0MHz	FM 106.0MHz	FM 108.1MHz
SOUTH AFRICA	1 to 8	AM 603kHz	AM 999kHz	AM 1404kHz	FM 88.0MHz	FM 90.0MHz	FM 98.0MHz	FM 106.0MHz	FM 108.0MHz
	9 to 16	AM 522kHz	AM 999kHz	AM 1011kHz	FM 87.4MHz	FM 90.0MHz	* FM 98.0MHz	FM 100.0MHz	FM 108.1MHz

\* = FM AUTO

Chart 6-1

NOTE: For U, Y1 model only, Set AM STEP SW to 9kHz, which located on the rear panel.

## VII. PC BOARD TITLES AND IDENTIFICATION NUMBERS

### MODEL AA-A25

PC Board Title		PC Board Number	Remarks
MAIN AMP	PC BOARD	A1007A501A	U, Y <sub>1</sub>
		A1007A508A	C, A
		A1007A509A	E, V, S
POWER	PC BOARD	A1007A501B	U, Y <sub>1</sub>
		A1007A508B	C, A
		A1007A509C	E, V, S
HEAD PHONE	PC BOARD	A1007A501E	
SPEAKER	PC BOARD	A1007A501G	U, C, A, E, S, Y <sub>1</sub>
FILTER	PC BOARD	A1007A509D	V
CONTROL (A)	PC BOARD	A1007A504A	
CONTROL (B)	PC BOARD	A1007A504B	
PRE AMP	PC BOARD	A1007B503A	
PIN JACK	PC BOARD	A1007B503B	
TUNER	PC BOARD	A1007B502A	U, C, A, E, V, S, Y <sub>1</sub>
MPX	PC BOARD	A1007B507B	
FRONT END	PC BOARD	A3040A5200	

### MODEL AA-A25/L

PC Board Title		PC Board Number	Remarks
MAIN AMP	PC BOARD	A1007A509A	B, E
POWER	PC BOARD	A1007A509C	B, E
HEAD PHONE	PC BOARD	A1007A501E	
SPEAKER	PC BOARD	A1007A501G	
CONTROL (A)	PC BOARD	A1007A504A	
CONTROL (B)	PC BOARD	A1007A504B	
PRE AMP	PC BOARD	A1007B503A	
PIN JACK	PC BOARD	A1007B503B	
TUNER	PC BOARD	A1007B507A	B, E
MPX	PC BOARD	A1007B507B	
FRONT END	PC BOARD	A3040A5200	

## 6-5 LW SECTION ADJUSTMENT (for AA-A25L)

Step	Adjustment Item	Adjustment Point	Result	Remarks
1	LW OSC	T4	7.0V at 353kHz	Band SW to LW. 353kHz input. Display to 353kHz. Connect DC Voltmeter to TP2.
2	Low Range Sensitivity	T2	Less than 65 dB input from SSG	160kHz input. Display to 160kHz. 10% Distortion Factor.
3	High Range Sensitivity	VC2	Less than 65dB input from SSG	300kHz input. Display to 300kHz. 10% Distortion Factor.
4	For best Result, Repeat steps 2 and 3 two or three times			
5	Middle Range Sensitivity (Confirmation)	None	Less than 65dB input from SSG	200kHz input. Display to 200kHz. 10% Distortion Factor.
6	Distortion (Confirmation)	None	Less than 2.5%	200kHz, 74dB input. Display to 200kHz.

**NOTE:** Set the internal modulation signal generator to 30%, 1kHz of each.

## 6-6 AM (MW) SECTION ADJUSTMENT

Step	Adjustment Item	Adjustment Point	Result	Remarks
1	AM (MW) OSC (See NOTE 3)	T3	6.7V at 1400kHz (1404kHz)	Band SW to AM (MW) 1400kHz, (1404kHz) input. Display to 1400kHz (1404kHz). Connect DC Voltmeter to TP2.
2	Low Range Sensitivity	T1	Less than 60dB input from SSG	600kHz (603kHz) input. Display to 600kHz (603kHz) 10% Distortion Factor.
3	High Range Sensitivity	VC1	Less than 60dB input from SSG	1400kHz (1404kHz) input. Display to 1400kHz (1404kHz). 10% Distortion Factor.
4	For best Result, Repeat steps 2 and 3 two or three times			
5	Middle Range Sensitivity (Confirmation)	None	Less than 60dB input from SSG	1000kHz (999kHz) input. Display to 1000kHz (999kHz) 10% Distortion Factor.
6	Distortion (Confirmation)	None	Less than 2.0%	1000kHz, (999kHz) 74dB input. Display to 1000kHz (999kHz).
7	AM IF	T5, T6	Maximum output Minimum Distortion	1000kHz (999kHz) 74dB input. Display to 1000kHz (999kHz).

- NOTES:**
1. Set the internal modulation signal generator to 30%, 1kHz of each.
  2. ( kHz) in Result & Remarks indicates the test frequencies in AM 9kHz STEP area.
  3. For the model AA-A25L, adjust LW OSC prior to this adjustment for the best result.

### ATTENTION

1. When placing an order for parts, be sure to list the parts no., model no., and description. There are instances in which if any of this information is omitted, parts cannot be shipped or the wrong parts will be delivered.
2. Please be careful not to make a mistake in the parts no. If the parts no. is in error, a part different from the one ordered may be delivered.
3. Because parts number and parts unit supply in the Preliminary Parts List may be partially changed, please use this parts list for all future reference.

### HOW TO USE THIS PARTS LIST

1. This Parts List shows the parts that are considered necessary for repairs. Other parts, such as resistors and capacitors, are shown in the "Common List for Service Parts". Select and order such parts from the "Common List for Service Parts".
2. The Recommended Spare Parts shows those parts in the Parts List which are considered particularly important for service.
3. Parts not shown in the Parts List and "Common List for Service Parts" will not be supplied in principle.

#### 4. How to read list

a) Mechanism Block

b) P.C Board Block

#### 2. HEAD BASE BLOCK

REF. NO.	PARTS NO.	DESCRIPTION
2-1x	BH-T2023A320A	HEAD BASE BLOCK GX-F66R
2-2	HP-H2206A010A	HEAD R/P PR4-8FU C
2-3	ZS-477876	PAN20x03STL CMT
2-4	ZS-536488	BID20x08STL CMT
2-5	ZG-402895	CS ANGLE ADJUST SPRING

SP (Service Parts) Classification

A small "x" indicates the inability to show that particular part in the Photo or Illustration.

This number corresponds with the individual parts index number in that figure

This number corresponds with the Figure Number

#### 6. SYS. CON. P.C BOARD BLOCK

REF. NO.	PARTS NO.	DESCRIPTION
6-1	BA-T2034A070A	PC SYS CON BLK GX-F44R
6-IC1	EI-324536	IC HD14049BP
6-IC2	EI-336801	IC MB8841-564M
6-IC3	EI-331661	IC SN7405N
6-IC4	EI-336725	IC M54527P
6-TR1to4	ET-200985	TR 2SC2603 F,G
6-TR5to28	ET-554657	TR 2SA733A P,Q
6-D1	ED-318292	D SILICON H 1S2473T-77 T26
6-D2to4	ED-308952	D GERMA V 1K34A-LR F07
6-D5to10	ED-318292	D SILICON H 1S2473T-77 T26
6-X1	EI-318384	OSC X'TAL NC-18C 3.579545MHZ

SP (Service Parts) Classification

This reference numbers corresponds with symbol numbers of Schematic Diagrams.

5. Both the kind of part and installation position can be determined by the Parts Number. To determine where a parts number is listed, utilize Parts Index at end of Parts List. It is necessary first of all to find the Parts Number. This can be accomplished by using the Reference Number listed at right of parts number in the Parts Index.

### WARNING

⚠ INDICATES SAFETY CRITICAL COMPONENTS. FOR CONTINUED SAFETY, REPLACE SAFETY CRITICAL COMPONENTS ONLY WITH MANUFACTURER'S RECOMMENDED PARTS.

### AVERTISSEMENT

⚠ IL INDIQUE LES COMPOSANTS CRITIQUES DE SURETE. POUR MAINTENIR LE DEGRE DE SECURITE DE L'APPAREIL NE REMPLACER LES COMPOSANTS DONT LE FONCTIONNEMENT EST CRITIQUE POUR LA SECURITE QUE PAR DES PIECES RECOMMANDEES PAR LE FABRICANT.



---

SECTION 2

**PARTS LIST**

TABLE OF CONTENTS

RECOMMENDED SPARE PARTS .....	21
1. TUNER PC BOARD BLOCK .....	22
2. FRONT END PC BOARD BLOCK .....	22
3. PRE AMP PC BOARD BLOCK .....	23
4. MAIN AMP PC BOARD BLOCK .....	23
5. CONTROL PC BOARD BLOCK .....	23
6. ASSEMBLY BLOCK .....	24
7. FINAL ASSEMBLY BLOCK .....	26
INDEX .....	27

Resistors and Capacitors which are not listed in this parts list, please refer to COMMON LIST FOR SERVICE PARTS.

# 1. TUNER PC BOARD BLOCK

REF. NO.	PARTS NO.	DESCRIPTION
1-1U	BA-A1007A060A	PC TUNER BLK AA-A25(U,Y1)
1-1C	BA-A1007A060B	PC TUNER BLK AA-A25(C,A)
1-1E	BA-A1007A060C	PC TUNER BLK AA-A25(E,S)
1-1V	BA-A1007A060D	PC TUNER BLK AA-A25(V)
1-1LE	BA-A1007A060E	PC TUNER BLK AA-A25L(E)
1-1LB	BA-A1007A060F	PC TUNER BLK AA-A25L(B)
<b>TUNER PC BOARD</b>		
1-IC1	EI-202218	IC LA1245
1-IC2	EI-322248	IC LA1231N
1-IC3	EI-336717	IC TC9125BP
1-IC4	EI-315381	IC TD6102P
1-TR1	ET-338410	TR 2SC2878 A,B (LE,LB)
1-TR2to4	ET-403413	TR 2SC536NP H (LE,LB)
1-TR5	ET-423224	TR FET 2SK19 BL (LE,LB)
1-TR6	ET-336935	TR 2SC3000 D2,E,F
1-TR7	ET-322244	TR 2SA608K-NP F,G
1-TR8to10	ET-403413	TR 2SC536NP H
1-TR11,12	ET-353366	TR 2SC3112 A,B
1-TR13,14	ET-403413	TR 2SC536NP H
1-TR15	ET-322244	TR 2SA608K-NP F,G
1-TR16	ET-308141	TR 2SC2603 G (V)
1-TR17	ET-349081	TR 2SC3383 S,T
1-TR18	ET-336864	TR FET 2SK223 F
1-TR19	ET-349081	TR 2SC3383 S,T
1-D1,2	ED-349460	D VARACTOR SVC321 C,D
1-D3,4	ED-344280	D SILICON H GMA-01-FY2 F05 (LE,LB)
1-D5	ED-348205	D SILICON V MC931 DOUBLE
1-D6	ED-301911	D SILICON H DS448
1-D7,8	ED-344280	D SILICON H GMA-01-FY2 F05
1-D9	ED-301911	D SILICON H DS448
1-D10	ED-344280	D SILICON H GMA-01-FY2 F05
1-D11	ED-301911	D SILICON H DS448
1-D12	ED-302295	D ZENER H HZ7 C3
1-SW1	ES-344445	SW TACT EVQ-QHR12B
1-SW2	ES-347122	SW SLIDE 00420569 2-04-2S (U,Y1)
1-T1	EO-337598	COIL VARI 2 25A-1353-01
1-T2	EO-337599	COIL VARI 2 25A-1354-03 (LE,LB)
1-T3U	EO-348209	COIL OSC 2 7NR-8646Y 115.0 UH (U,Y1,C,A,E,V,S)
1-T3L	EO-349456	COIL OSC 2 7NRS-9153Z 150.0UH (LE,LB)
1-T4	EO-352089	COIL OSC 2 7BRS-9098X 580.0UH (LE,LB)
1-T5	EO-353176	COIL IFT PEGK0008B-01 455.0KHZ
1-T6	EO-202216	COIL IFT 7MC-6733C 460.0KHZ
1-T7	EO-349452	COIL DET 2 78-1045-01
1-T8	EO-349453	COIL DET 2 78-1046-01
1-FL1	EH-315407	FILTER CE SFE10.7MMKA 10.7MHZ
1-FL2U	EH-336804	FILTER CE SFE10.7MA8 10.7MHZ (U,Y1,C,A,E,S,LB)
1-FL2V	EH-338338	FILTER CE MS3GKY-A 10.700MHZ (V,LE)
1-FL3U	EH-343352	FILTER CE SFU459B9 0.459MHZ (EXCEPT C,A)
1-FL3C	EH-343353	FILTER CE SFU460B9 0.460MHZ (C,A)
1-FL4U	EH-337327	FILTER CE BFU459C4N 0.459MHZ (EXCEPT C,A)
1-FL4C	EH-337328	FILTER CE BFU460C4N 0.46MHZ (C,A)
1-FL5	EH-336830	FILTER LC LP BL-34HD (V)
1-X1	EI-327074	OSC X'TAL HC-18/U 9.000000MHZ
1-VC1	EC-330692	C S-FIX H TZ03R200E 4.2-20
1-VC2	EC-330692	C S-FIX H TZ03R200E 4.2-20 (LE,LB)
1-R5	ER-324185	△ R CB H S10 FS RDS 1/4W 221J
1-R6	ER-315046	△ R CB H F10 RDS 1/4W 121J
1-R34,35	ER-324337	△ R CB H S10 FS RDS 1/4W 560J

REF. NO.	PARTS NO.	DESCRIPTION
1-R36,37	ER-324480	△ R CB H S10 FS RDS 1/4W 470J
1-R52,53	ER-324337	△ R CB H S10 FS RDS 1/4W 560J
1-R86	ER-328067	△ R CB H S10 FS RDS 1/4W 331J (V)
1-R96	ER-315046	△ R CB H F10 RDS 1/4W 121J
1-R97	ER-324934	△ R CB H S10 FS RDS 1/4W 220J
1-C22	EC-351134	C PP V F05 PP 4300G 50DC
1-C23	EC-352097	C PP V F05 PP 2700G 50DC (LE,LB)
1-C59	EC-347591	C MMY V F05 MMH 474M 100DC
1-TM1	EJ-344423	TERMINAL W/SCREW YKD31-0133 P 2P

## MPX PC BOARD

REF. NO.	PARTS NO.	DESCRIPTION
1-IC1B	EI-343349	IC LA3390
1-TR1Bto3B	ET-349081	TR 2SC3383 S,T
1-D1B	ED-346603	D ZENER H HZ6 A1
1-D2Bto5B	ED-301911	D SILICON H DS448
1-VR1B	EV-344828	R S-FIX V RVF8 W01 3P 203
1-VR2B	EV-352088	R S-FIX V RVF8W01 3P 103
1-FL1B	EH-341654	FILTER LC LP 42W-1001
1-R1B,2B	ER-324337	△ R CB H S10 FS RDS 1/4W 560J
1-C4BU	EC-344486	C PP V F05 PP 391J 50DC (EXCEPT C,A)
1-C4BC	EC-344478	C PP V F05 PP 561J 50DC (C,A)
1-C5BU	EC-344486	C PP V F05 PP 391J 50DC (EXCEPT C,A)
1-C5BC	EC-344478	C PP V F05 PP 561J 50DC (C,A)
1-C6B,7B	EC-344155	C PP V F05 PP 181J 50DC (U,Y1)
1-C12B,13B	EC-344484	C PP V F05 PP 392J 50DC
1-C15B	EC-344483	C PP V F05 PP 102J 50DC

# 2. FRONT END PC BOARD BLOCK

REF. NO.	PARTS NO.	DESCRIPTION
2-1U	BA-A3040A040A	PC FRONT END BLK AT-M77 (U,C,A,E,S,LE,LB)
2-1V	BA-A3040A040D	PC FRONT END BLK AA-A25(V)
2-1Y1	BA-A3040A040F	PC FRONT END BLK AA-A25(Y1)
<b>FRONT END PC BOARD</b>		
2-TR1	ET-337743	TR FET 3SK107 E
2-TR2	ET-336869	TR 2SC2999 C,D
2-TR3	ET-328265	TR 2SC930 F
2-TR4	ET-349449	TR FET 2SK161 O,Y
2-D1to4	ED-336832	D VARACTOR SVC211SP
2-L1	EO-349461	COIL FIX 2 LINK
2-L2	EO-349462	COIL FIX 2 U147
2-L3	EO-349461	COIL FIX 2 LINK
2-L4,5	EO-349462	COIL FIX 2 U147
2-L6U	EO-349446	COIL OSC 2 TFE2-OSC-U (EXCEPT Y1)
2-L6Y1	EO-349447	COIL OSC 2 TFE2-OSC-J(Y1)
2-L7	EO-336934	COIL FIX 1 LAL03KH 2R2M
2-T1	EO-337640	COIL IFT 119AC-15533X 10.7MHZ
2-VC1,2	EC-352419	C S-FIX H TZ03N100E 2.1-10
2-VC4	EC-352419	C S-FIX H TZ03N100E 2.1-10
2-C26	EC-349083	C STY V CUT CQ09S2B 101J 125DC

## RECOMMENDED SPARE PARTS

Because, if the parts listed below are on hand, almost any repair can be accomplished, we suggest that you stock these Recommended Spare Parts Items.

NO.	PARTS NO.	DESCRIPTION
1	N BT-351481	△ TRANS POWER AA-A25T-30(C,A)
2	N BT-351482	△ TRANS POWER AA-A25T-40 (E,V,LE)
3	N BT-351483	△ TRANS POWER AA-A25T-50 (S,LB)
4	N BT-351484	△ TRANS POWER AA-A25T-70 (U,Y1)
5	EC-352419	C S-FIX H T203N100E 2.1-10
6	EC-330692	C S-FIX H T203R200E 4.2-20
7	ED-200213	D SILICON DBA40C-K15 200/2.6A
8	ED-345555	D SILICON DBB10C 200/1.0A
9	ED-301911	D SILICON H DS448
10	ED-344280	D SILICON H GMA-01-FY2 F05
11	ED-348205	D SILICON V MC931 DOUBLE
12	ED-349460	D VARACTER SVC321 C,D
13	ED-336832	D VARACTER SVC211SP
14	ED-328486	D ZENER H HZ15 3
15	ED-316540	D ZENER H HZ20 1
16	ED-346624	D ZENER H HZ30 2
17	ED-337292	D ZENER H HZ5 B1
18	ED-346603	D ZENER H HZ6 A1
19	ED-331617	D ZENER H HZ6 A3
20	ED-319167	D ZENER H HZ6 C3
21	ED-346604	D ZENER H HZ7 B2
22	ED-302295	D ZENER H HZ7 C3
23	EF-668474	△ FUSE SEMKO T 250V 0.40A (E,V,S,LE,LB)
24	EF-602550	△ FUSE SEMKO T 250V 1.25A (E,V,S,LE,LB)
25	EF-601301	△ FUSE SEMKO T 250V 2.00A (E,V,S,LE,LB)
26	EF-311839	△ FUSE TSC A 250V 1.60A (U,Y1)
27	EF-306951	△ FUSE TSC A 250V 2.50A (U,Y1)
28	EF-309390	△ FUSE TSC 125V 0.50A (C,A)
29	EF-306956	△ FUSE TSC 125V 2.50A (C,A)
30	EF-306957	△ FUSE TSC 125V 4.00A (C,A)
31	EH-337327	FILTER CE BFU459C4N 0.459MHZ (EXCEPT C,A)
32	EH-337328	FILTER CE BFU460C4N 0.46MHZ (C,A)
33	EH-338338	FILTER CE MS3GKY-A 10.700MHZ (V,LE)
34	EH-336804	FILTER CE SFE10.7MA8 10.7MHZ (U,Y1,C,A,E,S,LB)
35	EH-315407	FILTER CE SFE10.7MMKA 10.7MHZ
36	EH-343352	FILTER CE SFU459B9 0.459MHZ (EXCEPT C,A)
37	EH-343353	FILTER CE SFU460B9 0.460MHZ (C,A)
38	EH-336830	FILTER LC LP BL-34HD (V)
39	EH-341654	FILTER LC LP 42W-1001
40	N EI-353059	IC A1007A2
41	N EI-351969	IC A1007T
42	EI-322248	IC LA1231N
43	EI-202218	IC LA1245
44	EI-343349	IC LA3390
45	EI-343417	IC LB1294
46	EI-345479	IC LC7910
47	EI-349719	IC M5218P
48	EI-344764	IC M5218P-21
49	EI-348785	IC M5220L
50	EI-346122	IC STK4833
51	EI-336717	IC TC9125BP
52	EI-343373	IC TC9156P
53	EI-349392	IC TC9164N
54	N EI-351966	IC TC9176P
55	EI-315381	IC TD6102P
56	EI-327074	OSC X'TAL HC-18/U 9.000000MHZ
57	N EM-351967	IND FL BG-214ZK DOUBLE
58	EO-353176	COIL IFT PEGK0008B-01 455.0KHZ

NO.	PARTS NO.	DESCRIPTION
59	EO-337640	COIL IFT 119AC-15533X 10.7MHZ
60	EO-202216	COIL IFT 7MC-6733C 460.0KHZ
61	EO-337598	COIL VARI 2 25A-1353-01
62	EO-337599	COIL VARI 2 25A-1354-03
63	ER-326169	△ R FUSE ERD2FC S10 1/4W 22R0G
64	ER-328278	△ R FUSE ERD2FC 1/4W 10R0G
65	ES-349070	△ SW SELECT YKS11-0002 02-4(U,Y1)
66	N ES-351965	SW PUSH ESB8215V
67	N ES-351964	SW PUSH SUL221A 2-THROW
68	ES-347122	SW SLIDE 00420569 2-04-2S (U,Y1)
69	ES-344445	SW TACT EVQ-QHR12B
70	ES-336780	SW TACT KHH10902
71	ET-349449	TR FET 2SK161 O,Y
72	ET-423224	TR FET 2SK19 BL
73	ET-336864	TR FET 2SK223 F
74	ET-337759	TR FET 2SK246 GR
75	ET-337743	TR FET 3SK107 E
76	ET-345626	TR 2SA1248 S,T
77	ET-322244	TR 2SA608K-NP F,G
78	ET-308141	TR 2SC2603 G
79	ET-338410	TR 2SC2878 A,B
80	ET-336869	TR 2SC2999 C,D
81	ET-336935	TR 2SC3000 D2,E,F
82	N ET-353366	TR 2SC3112 A,B
83	ET-345625	TR 2SC3116 S,T
84	ET-349081	TR 2SC3383 S,T
85	ET-403413	TR 2SC536NP H
86	ET-328265	TR 2SC930 F
87	ET-349459	TR 2SD1406 O,Y,GR
88	ET-208012	TR 2SD571 K
89	N EV-344828	R S-FIX V RVF8 W01 3P 203
90	N EV-352088	R S-FIX V RVF8 W01 3P 103

"NOTE" N: New Parts

### SYMBOL FOR DESTINATION

- A : AAL (U.S.A)
- B : UK (England)
- C : CSA (Canada)
- E : CEE (Europe)
- S : SAA (Australia)
- U : U/T (Universal Area)
- V : VDE (West Germany)



**ASSEMBLY BLOCK**

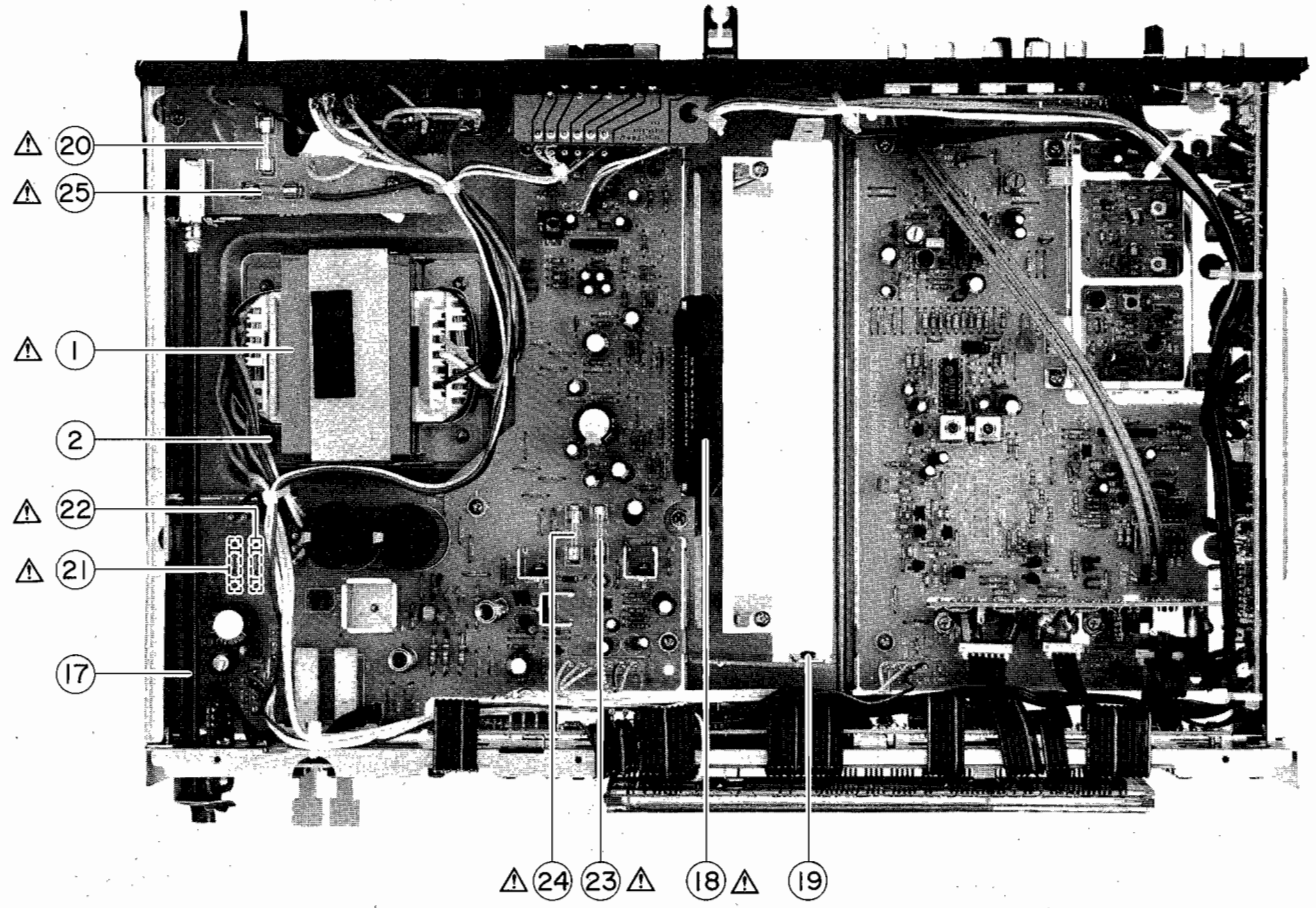
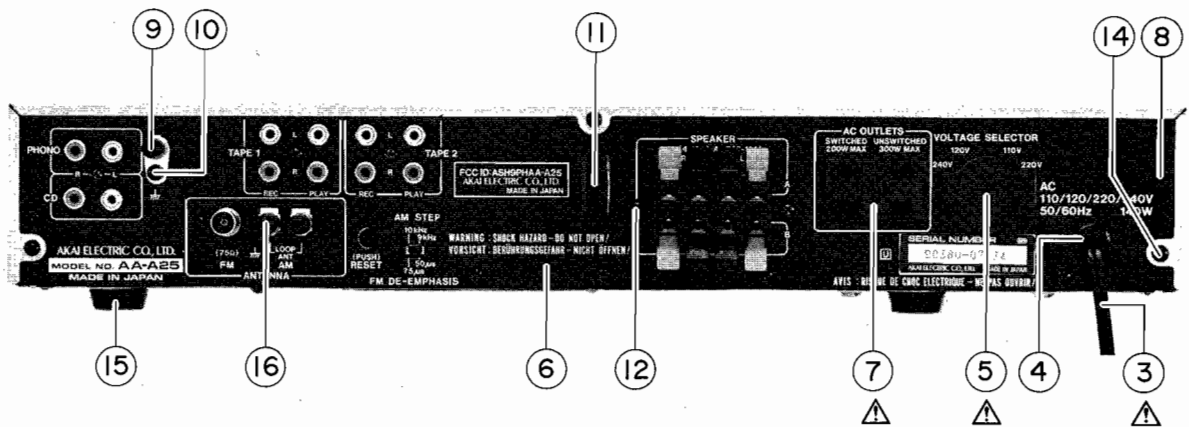

### 3. PRE AMP PC BOARD BLOCK

REF. NO.	PARTS NO.	DESCRIPTION
3-1U	BA-A1007A070A	PC PRE AMP BLK AA-A25 (U,C,A,E,B,S,L,Y1)
3-1V	BA-A1007A070B	PC PRE AMP BLK AA-A25(V)
<b>PRE AMP PC BOARD</b>		
3-IC1	EI-344764	IC M5218P-21
3-IC2	EI-349392	IC TC9164N
3-IC3	EI-349719	IC M5218P
3-IC4	EI-351966	IC TC9176P
3-IC5,6	EI-343373	IC T9156P
3-D1,2	ED-346603	Δ D ZENER H HZ6 A1
3-VL1	EO-337684	COIL FIX 2 FL12R751E 751K(V)
3-VL2	EO-345918	COIL FIX 1 LAL03KH 220K(V)
3-R12,13	ER-200944	Δ R CB H S10 FS RDS 1/4W 152J
3-J1	EJ-336905	PIN J AJC-035-ACB P 4P
<b>PIN JACK PC BOARD</b>		
3-VL1 Bto4B	EO-345918	COIL FIX 1 LAL03KH 220K(V)
3-J1B,2B	EJ-336915	PIN J AJC-054-ABB P 4P

### 4. MAIN AMP PC BOARD BLOCK

REF. NO.	PARTS NO.	DESCRIPTION
4-1U	BA-A1007A040A	PC MAIN AMP BLK AA-A25(U,Y1)
4-1C	BA-A1007A040B	PC MAIN AMP BLK AA-A25(C,A)
4-1E	BA-A1007A040C	PC MAIN AMP BLK AA-A25 (E,S,LE,LB)
4-1V	BA-A1007A040D	PC MAIN AMP BLK AA-A25(V)
<b>MAIN AMP PC BOARD</b>		
4-IC2	EI-348785	IC M5220L
4-TR1	ET-322244	Δ TR 2SA608K-NP F,G
3-TR2	ET-345625	Δ TR 2SC3116 S,T
4-TR3,4	ET-345626	Δ TR 2SA1248 S,T
4-TR5	ET-349459	Δ TR 2SD1406 O,Y,GR
4-TR6	ET-208012	Δ TR 2SD571 K
4-TR7	ET-345625	Δ TR 2SC3116 S,T
4-TR8	ET-403413	TR 2SC536NP H
4-TR9	ET-337759	TR FET 2SK246 GR
4-D1	ED-200213	Δ D SILICON DBA40C-K15 200/2.6A
4-D2	ED-345555	Δ D SILICON DBB10C 200/1.0A
4-D3,4	ED-328486	Δ D ZENER H HZ15 3
4-D5	ED-346624	Δ D ZENER H HZ30 2
4-D6	ED-316540	Δ D ZENER H HZ20 1
4-D7	ED-328486	Δ D ZENER H HZ15 3
4-D8	ED-319167	Δ D ZENER H HZ6 C3
4-D9	ED-331617	Δ D ZENER H HZ6 A3
4-D10,11	ED-301911	D SILICON H DS448
4-D12	ED-337292	D ZENER H HZ5 B1
4-D13	ED-301911	D SILICON H DS448
4-D14	ED-337292	D ZENER H HZ5 B1
4-D15,16	ED-301911	D SILICON H DS448
4-SW1	ES-351964	SW PUSH SUL221A 2-THROW
4-L1	EO-337880	COIL FIX 2 202AK-018 2R2K
4-FR1	ER-328278	Δ R FUSE ERD2FC 1/4W 10R0G
4-FR2,3	ER-326169	Δ R FUSE ERD2FC S10 1/4W 22R0G
4-R9	ER-311685	Δ R CB H S15 FS RDS 1/2W 4R7J
4-R13	ER-200940	Δ R CB H S10 FS RDS 1/4W 671J
4-R17	ER-311685	Δ R CB H S15 FS RDS 1/2W 4R7J
4-R18	ER-308028	Δ R OMF H S15 FS 1W 181J
4-R28	ER-353359	Δ R OMF H S15 FS 1W 392J
4-R32	ER-327710	Δ R CB H S10 FS RDS 1/4W 151J
4-R35	ER-345659	R OMF H S15 FS 1W 272J
4-C9	EC-343855	C EC V F05 NP SM R22M 50.0DC
4-C10,11	EC-333971	C EC V F05 NP SM 2R2M 50DC
4-C19,20	EC-345605	C EC V S10 682M 45.0DC

REF. NO.	PARTS NO.	DESCRIPTION
4-C22	EC-326583	C MMY V CUT CF921 473K 400DC
4-C25	EC-325109	C EC V CUT SM 102M 50DC
4-C28	EC-201751	C EC V CUT USM 102M 50DC
<b>POWER PC BOARD (U,C,A,Y1)</b>		
4-SW1B	ES-351965	Δ SW PUSH ESB8215V(U,Y1,C,A)
4-R1B	ER-672816	Δ R CB H RD 1/2W 225J(C,A)
4-C1B	EC-338411	Δ C CE V FZ 103P 400AC (U,Y1,C,A)
<b>POWER PC BOARD(E,S,V,LE,LB)</b>		
4-SW1C	ES-351965	Δ SW PUSH ESB8215V (E,S,V,LE,LB)
4-L1C	EO-338409	COIL LF FKOB160MH02 250UH (V)
4-C1C	EC-338411	Δ C CE V FZ 103P 400AC (E,S,V,LE,LB)
<b>FILTER PC BOARD</b>		
4-L1D,2D	EO-342936	COIL BALUN (V)
<b>HEAD PHONE PC BOARD</b>		
4-VL1E	EO-345918	COIL FIX 1 LAL03KH 220K (V)
4-J2E	EJ-351963	PHONE J 3P YKB21-5060 6.3
<b>SPEAKER PC BOARD</b>		
4-TM1G	EJ-349401	TERMINAL LEVER YKD21-0027 8P (EXCEPT V)

### 5. CONTROL PC BOARD BLOCK

REF. NO.	PARTS NO.	DESCRIPTION
5-1U	BA-A1007A020A	PC CONTROL BLK AA-A25(U)
5-1C	BA-A1007A020B	PC CONTROL BLK AA-A25(C,A)
5-1E	BA-A1007A020C	PC CONTROL BLK AA-A25(E,V,S)
5-1L	BA-A1007A020D	PC CONTROL BLK AA-A25L(E,B)
5-1Y1	BA-A1007A020E	PC CONTROL BLK AA-A25(Y1)
<b>CONTROL (A) PC BOARD</b>		
5-IC1	EI-353059	IC A1007A2
5-IC2	EI-351969	IC A1007T
5-IC3,4	EI-343417	IC LB1294
5-IC5	EI-345479	IC LC7910
5-TR1,2	ET-322244	TR 2SA608K-NP F,G
5-TR3	ET-403413	TR 2SC536NP H(U)
5-D1	ED-346604	D ZENER H HZ7 B2
5-D2	ED-301911	D SILICON H DS448
5-D2	ED-301911	D SILICON H DS448
5-D3	ED-301911	D SILICON H DS448(U,C,A)
5-D4	ED-301911	D SILICON H DS448(U,E,V,S)
5-D5	ED-301911	D SILICON H DS448(LE,LB,Y1)
5-D6to16	ED-301911	D SILICON H DS448
5-D17	ED-301911	D SILICON H DS448(U)
5-D18	ED-301911	D SILICON H DS448(Y1)
5-X1,2	EI-352673	OSC X'TAL HC-49/U 4.1MHZ
5-SR1	EH-352048	COMP R RKC1/8B6 4.7K J
5-SR2,3	EH-352059	COMP R RKC1/8B6D 100K J
5-SR4	EH-352060	COMP R RKC1/8B3 4.7K J
5-SR5	EH-352061	COMP R RKC1/8B8D 100K J
5-SR6	EH-352062	COMP R RKC1/8B6 100K J
5-SR7	EH-352063	COMP R RKC1/8B4D 100K J
5-SR8,9	EH-351973	COMP R RKC1/8B4 4.7K J
5-SR10	EH-352064	COMP R RKC1/8B4 100K J
5-SR11	EH-351976	COMP R RKC1/8B7 4.7K J
5-C1	EC-344157	C DOUBLE LAYER 473Z 5.5DC
<b>CONTROL (B) PC BOARD</b>		
5-SW1to30	ES-336780	SW TACT KHH10902
5-IN1	EM-351967	IND FL BG-214ZK DOUBLE

## FINAL ASSEMBLY BLOCK

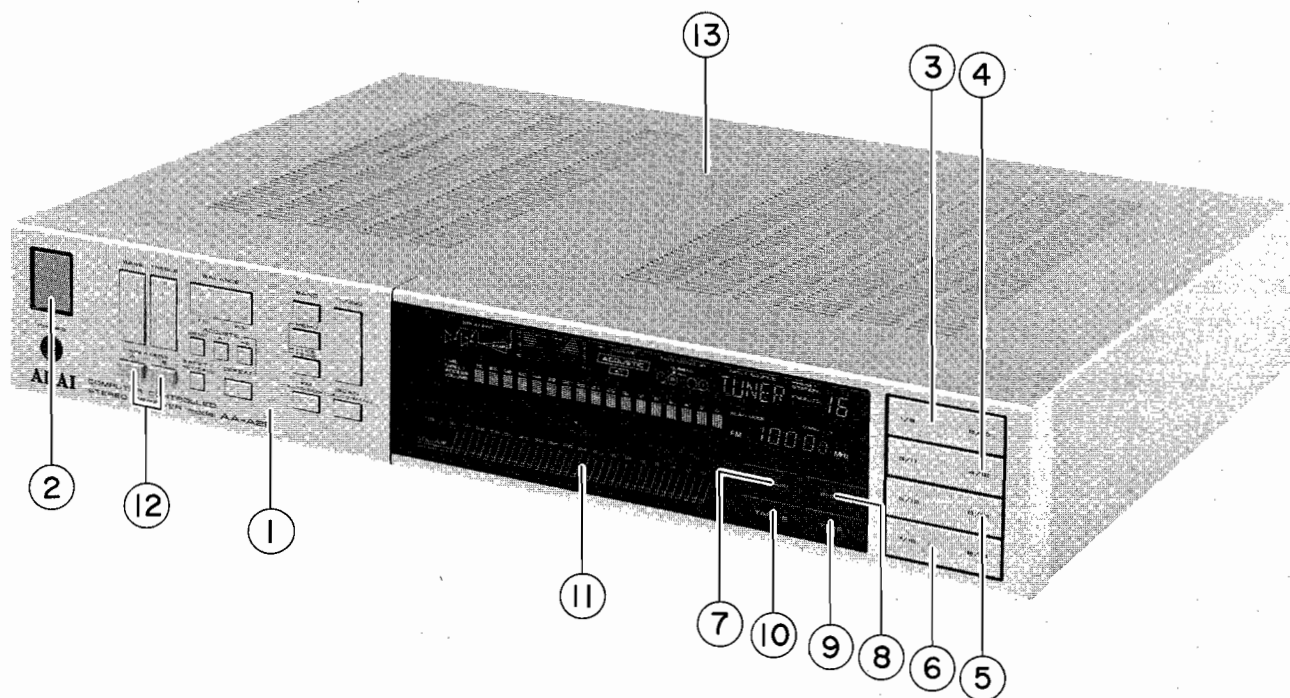

### 7. FINAL ASSEMBLY BLOCK

REF. NO.	PARTS NO.	DESCRIPTION
----------	-----------	-------------

#### PANEL FRONT BLOCK

7-1	BD-A1007A050A	PANEL FRONT BLK AA-A25
7-1L	BD-A1007A050B	PANEL FRONT BLK AA-A25L
7-1P	BD-A1007A050C	PANEL FRONT BLK AA-A25-P
7-1LP	BD-A1007A050D	PANEL FRONT BLK AA-A25L-P
7-2	SK-343017C	KNOB POWER (2)
7-2P	SK-343017D	KNOB POWER (2)-P
7-3	SK-351445A	KNOB (A)
7-3P	SK-351445E	KNOB (A)-P
7-4	SK-351445B	KNOB (B)
7-4P	SK-351445F	KNOB (B)-P
7-5	SK-351445C	KNOB (C)
7-5P	SK-351445G	KNOB (C)-P
7-6	SK-351445D	KNOB (D)
7-6P	SK-351445H	KNOB (D)-P
7-7	SK-351446A	KNOB CD
7-8	SK-351446B	KNOB PHONO

REF. NO.	PARTS NO.	DESCRIPTION
----------	-----------	-------------

7-9	SK-351446C	KNOB TAPE (1)
7-10	SK-351446D	KNOB TAPE (2)

#### FINAL ASSEMBLY BLOCK

7-11	EV-351497	VR SPL MEMBRANE VS-115-2 B105
7-12	SK-351443A	KNOB PUSH (B)
7-12P	SK-351443B	KNOB PUSH (B)-P
7-13	SP-351455A	COVER UPPER
7-13P	SP-351455B	COVER UPPER-P
7-14x	SA-356540	ROUND FOOT SET

#### SYMBOL FOR COLOR VARIATION

NON : STANDARD COLOR  
P : PEARL SHADOW

## 6. ASSEMBLY BLOCK

REF. NO.	PARTS NO.	DESCRIPTION
6-1U	BT-351484	△ TRANS POWER AA-A25T-70 (U,Y1)
6-1C	BT-351481	△ TRANS POWER AA-A25-T-30 (C,A)
6-1E	BT-351482	△ TRANS POWER AA-A25T-40 (E,V,LE)
6-1B	BT-351483	△ TRANS POWER AA-A25T-50 (S,LB)
6-2	ZS-300519	ST PAN40×08STL CMT
6-3U	EW-374894	△ AC CORD 2 CORES VM-0129A, VFF U/T (U,Y1)
6-3C	EW-349427	△ AC CORD 2 CORES KP-8W, SPT-2 UC (C,A)
6-3E	EW-346251	△ AC CORD 2 CORES VM0364, NR N/815 EV (E,V,LE)
6-3S	EW-336924	△ AC CORD 2 CORES KP-560, LTSA-2F S (S)
6-3B	EW-346249	△ AC CORD 2 CORES LCFL2×0.75 B (L-B)
6-4	EZ-631945	STRAIN RELIEF SR-4N-4
6-5	ES-349070	△ SW SELECT YKS11-0002 02-4 (U,Y1)(SW901)
6-6U	SP-351450A	PANEL REAR AA-A25(U,Y1)
6-6C	SP-351450B	PANEL REAR AA-A25(A,C)
6-6E	SP-351450E	PANEL REAR AA-A25(V,E)
6-6S	SP-351450D	PANEL REAR AA-A25(S)
6-6LE	SP-351450G	PANEL REAR AA-A25L(E)
6-6LB	SP-351450F	PANEL REAR AA-A25L(B)
6-7U	EJ-343362	△ SOCKET OUTLET S2T732T174 JUC 2×2P (U,Y1)
6-7C	EJ-349837	△ SOCKET OUTLET S2T732T124 JUC (C,A)
6-8	ZS-308846	T2BR30×08STL BZN PROJECTION
6-9	EJ-329610	TERMINAL W/SCREW UB-0067 L 1P
6-10	ZS-308846	T2BR30×08STL BZN PROJECTION
6-11	SZ-332739	HOLDER ANTENNA
6-12	ZS-351886	PT BR30×10STL BNI
6-13x	EE-337976	ANT LOOP LA-200A
6-14	ZS-308846	T2BR30×08STL BZN PROJECTION
6-15	SA-202118	FOOT
6-16	EJ-344423	TERMINAL W/SCREW YKD31-0133 P 2P
6-17	TC-351442	JOINT POWER
6-18	EI-346122	△ IC STK4833
6-19	ZW-698308	RV NYL30×055 BL
6-20U	EF-311839	△ FUSE TSC A 250V 1.60A (U,Y1)(F1)
6-20C	EF-306957	△ FUSE TSC 125V 4.00A(C,A)(F1)
6-20E	EF-602550	△ FUSE SEMKO T 250V 1.25A (E,V,S,LE,LB)(F1)
6-21C	EF-309390	△ FUSE TSC 125V 0.50A(C,A)(F2)
6-21E	EF-668474	△ FUSE SEMKO T 250V 0.40A (E,V,S,LE,LB)(F2)
6-22C	EF-309390	△ FUSE TSC 125V 0.50A(C,A)(F3)
6-22E	EF-668474	△ FUSE SEMKO T 250V 0.40A (E,V,S,LE,LB)(F3)
6-23U	EF-306951	△ FUSE TSC A 250V 2.50A (U,Y1)(F4)
6-23C	EF-306956	△ FUSE TSC 125V 2.50A(C,A)(F4)
6-23E	EF-601301	△ FUSE SEMKO T 250V 2.00A (E,V,S,LE,LB)(F4)
6-24U	EF-306951	△ FUSE TSC A 250V 2.50A (U,Y1)(F5)
6-24C	EF-306956	△ FUSE TSC 125V 2.50A(C,A)(F5)
6-24E	EF-601301	△ FUSE SEMKO T 250V 2.00A (E,V,S,LE,LB)(F5)
6-25	EF-311839	△ FUSE TSC A 250V 1.60A (U,Y1)(F6)
6-26x	ZW-305013	RV POP32(C,A)

# INDEX

PARTS NO.	REF. NO.	PARTS NO.	REF. NO.	PARTS NO.	REF. NO.	PARTS NO.	REF. NO.
SA-202118	6-15						
SA-356540	7-14x						
SK-343017C	7-2						
SK-343017D	7-2P						
SK-351443A	7-12						
SK-351443B	7-12P						
SK-351445A	7-3						
SK-351445B	7-4						
SK-351445C	7-5						
SK-351445D	7-6						
SK-351445E	7-3P						
SK-351445F	7-4P						
SK-351445G	7-5P						
SK-351445H	7-6P						
SK-351446A	7-7						
SK-351446B	7-8						
SK-351446C	7-9						
SK-351446D	7-10						
SP-351450A	6-6U						
SP-351450B	6-6C						
SP-351450D	6-6S						
SP-351450E	6-6E						
SP-351450F	6-6LB						
SP-351450G	6-6LE						
SP-351455A	7-13						
SP-351455B	7-13P						
SZ-332739	6-11						
TC-351442	6-17						
ZS-300519	6-2						
ZS-308846	6-14						
ZS-308846	6-10						
ZS-308846	6-8						
ZS-351886	6-12						
ZW-305013	6-26x						
ZW-698308	6-19						

# INDEX

PARTS NO.	REF. NO.	PARTS NO.	REF. NO.	PARTS NO.	REF. NO.	PARTS NO.	REF. NO.
BA-A1007A020A	5-1U	ED-301911	5-D7	EI-345479	5-IC5	ES-336780	5-SW25
BA-A1007A020B	5-1C	ED-301911	5-D17	EI-346122	6-18	ES-336780	5-SW18
BA-A1007A020C	5-1E	ED-301911	5-D12	EI-348785	4-IC2	ES-336780	5-SW17
BA-A1007A020D	5-1L	ED-301911	5-D15	EI-349392	3-IC2	ES-336780	5-SW5
BA-A1007A020E	5-1Y1	ED-301911	5-D16	EI-349719	3-IC3	ES-336780	5-SW8
BA-A1007A040A	4-1U	ED-301911	5-D3	EI-351966	3-IC4	ES-336780	5-SW3
BA-A1007A040B	4-1C	ED-301911	5-D13	EI-351969	5-IC2	ES-336780	5-SW24
BA-A1007A040C	4-1E	ED-302295	1-D12	EI-352673	5-X2	ES-336780	5-SW2
BA-A1007A040D	4-1V	ED-316540	4-D6	EI-352673	5-X1	ES-336780	5-SW29
BA-A1007A060A	1-1U	ED-319167	4-D8	EI-353059	5-IC1	ES-336780	5-SW22
BA-A1007A060B	1-1C	ED-328486	4-D4	EJ-329610	6-9	ES-336780	5-SW15
BA-A1007A060C	1-1E	ED-328486	4-D3	EJ-336905	3-J1	ES-336780	5-SW4
BA-A1007A060D	1-1V	ED-328486	4-D7	EJ-336915	3-J1B	ES-336780	5-SW6
BA-A1007A060E	1-1LE	ED-331617	4-D9	EJ-336915	3-J2B	ES-336780	5-SW13
BA-A1007A060F	1-1LB	ED-336832	2-D2	EJ-343362	6-7U	ES-336780	5-SW28
BA-A1007A070A	3-1U	ED-336832	2-D1	EJ-344423	1-TM1	ES-336780	5-SW27
BA-A1007A070B	3-1V	ED-336832	2-D4	EJ-344423	6-16	ES-336780	5-SW23
BA-A3040A040A	2-1U	ED-336832	2-D3	EJ-349401	4-TM1D	ES-336780	5-SW7
BA-A3040A040D	2-1V	ED-337292	4-D14	EJ-349401	4-TM1G	ES-336780	5-SW21
BA-A3040A040F	2-1Y1	ED-337292	4-D12	EJ-349837	6-7C	ES-336780	5-SW26
BD-A1007A050A	7-1	ED-344280	1-D4	EJ-351963	4-J2E	ES-336780	5-SW30
BD-A1007A050B	7-1L	ED-344280	1-D3	EM-351967	5-IN1	ES-336780	5-SW12
BD-A1007A050C	7-1P	ED-344280	1-D8	EO-202216	1-T6	ES-336780	5-SW19
BD-A1007A050D	7-1LP	ED-344280	1-D7	EO-336934	2-L7	ES-336780	5-SW20
BT-351481	6-1C	ED-344280	1-D10	EO-337598	1-T1	ES-336780	5-SW1
BT-351482	6-1E	ED-345555	4-D2	EO-337599	1-T2	ES-336780	5-SW9
BT-351483	6-1B	ED-346603	1-D1B	EO-337640	2-T1	ES-336780	5-SW11
BT-351484	6-1U	ED-346603	3-D2	EO-337684	3-VL1	ES-344445	1-SW1
EC-201751	4-C28	ED-346603	3-D1	EO-337880	4-L1	ES-347122	1-SW2
EC-325109	4-C25	ED-346604	5-D1	EO-338409	4-L1C	ES-349070	6-5
EC-326583	4-C22	ED-346624	4-D5	EO-342936	4-L2D	ES-351964	4-SW1
EC-330692	1-VC2	ED-348205	1-D5	EO-342936	4-L1D	ES-351965	4-SW1B
EC-330692	1-VC1	ED-349460	1-D1	EO-345918	3-VL1B	ES-351965	4-SW1C
EC-333971	4-C11	ED-349460	1-D2	EO-345918	3-VL2	ET-208012	4-TR6
EC-333971	4-C10	EE-337976	6-13x	EO-345918	3-VL3B	ET-308141	1-TR16
EC-338411	4-C1C	EF-306951	6-23U	EO-345918	3-VL2B	ET-322244	1-TR7
EC-338411	4-C1B	EF-306951	6-24U	EO-345918	3-VL4B	ET-322244	1-TR15
EC-343855	4-C9	EF-306956	6-23C	EO-345918	4-VL1E	ET-322244	4-TR1
EC-344155	1-C7B	EF-306956	6-24C	EO-348209	1-T3U	ET-322244	5-TR2
EC-344155	1-C6B	EF-306957	6-20C	EO-349446	2-L6U	ET-322244	5-TR1
EC-344157	5-C1	EF-309390	6-22C	EO-349447	2-L6Y1	ET-328265	2-TR3
EC-344478	1-C4BC	EF-309390	6-21C	EO-349453	1-T7	ET-336864	1-TR18
EC-344478	1-C5BC	EF-311839	6-20U	EO-349453	1-T8	ET-336869	2-TR2
EC-344483	1-C15B	EF-311839	6-25	EO-349456	1-T3L	ET-336935	1-TR6
EC-344484	1-C12B	EF-601301	6-23E	EO-349461	2-L3	ET-337743	2-TR1
EC-344484	1-C13B	EF-601301	6-24E	EO-349461	2-L1	ET-337759	4-TR9
EC-344486	1-C4BU	EF-602550	6-20E	EO-349462	2-L2	ET-338410	1-TR1
EC-344486	1-C5BU	EF-668474	6-22E	EO-349462	2-L5	ET-345625	4-TR2
EC-345605	4-C20	EF-668474	6-21E	EO-349462	2-L4	ET-345625	4-TR7
EC-345605	4-C19	EH-315407	1-FL1	EO-352089	1-T4	ET-345626	4-TR3
EC-347591	1-C59	EH-336804	1-FL2U	EO-353176	1-T5	ET-345626	4-TR4
EC-349083	2-C26	EH-336830	1-FL5	ER-200940	4-R13	ET-349081	1-TR19
EC-351134	1-C22	EH-337327	1-FL4U	ER-200944	3-R12	ET-349081	1-TR1B
EC-352097	1-C23	EH-337328	1-FL4C	ER-200944	3-R13	ET-349081	1-TR3B
EC-352419	2-VC1	EH-338338	1-FL2V	ER-308028	4-R18	ET-349081	1-TR2B
EC-352419	2-VC4	EH-341654	1-FL1B	ER-311685	4-R17	ET-349081	1-TR17
EC-352419	2-VC2	EH-343352	1-FL3U	ER-311685	4-R9	ET-349449	2-TR4
ED-200213	4-D1	EH-343353	1-FL3C	ER-315046	1-R96	ET-349459	4-TR5
ED-301911	1-D9	EH-351973	5-SR8	ER-315046	1-R6	ET-353366	1-TR11
ED-301911	1-D6	EH-351973	5-SR9	ER-324185	1-R5	ET-353366	1-TR12
ED-301911	1-D11	EH-351976	5-SR11	ER-324337	1-R53	ET-403413	1-TR2
ED-301911	1-D2B	EH-352048	5-SR1	ER-324337	1-R35	ET-403413	1-TR14
ED-301911	1-D3B	EH-352059	5-SR3	ER-324337	1-R34	ET-403413	1-TR13
ED-301911	1-D5B	EH-352059	5-SR2	ER-324337	1-R1B	ET-403413	1-TR3
ED-301911	1-D4B	EH-352060	5-SR4	ER-324337	1-R2B	ET-403413	1-TR4
ED-301911	4-D11	EH-352061	5-SR5	ER-324337	1-R52	ET-403413	1-TR8
ED-301911	4-D15	EH-352062	5-SR6	ER-324480	1-R36	ET-403413	1-TR10
ED-301911	4-D10	EH-352063	5-SR7	ER-324480	1-R37	ET-403413	1-TR9
ED-301911	4-D16	EH-352064	5-SR10	ER-324934	1-R97	ET-403413	4-TR8
ED-301911	4-D13	EI-202218	1-IC1	ER-326169	4-FR2	ET-403413	5-TR3
ED-301911	5-D11	EI-315381	1-IC4	ER-326169	4-FR3	ET-423224	1-TR5
ED-301911	5-D14	EI-322248	1-IC2	ER-327710	4-R32	EV-344828	1-VR1B
ED-301911	5-D5	EI-327074	1-X1	ER-328067	1-R86	EV-351497	7-11
ED-301911	5-D18	EI-336717	1-IC3	ER-328278	4-FR1	EV-352088	1-VR2B
ED-301911	5-D8	EI-343349	1-IC1B	ER-345659	4-R35	EW-336924	6-3S
ED-301911	5-D4	EI-343373	3-IC6	ER-353359	4-R28	EW-346249	6-3B
ED-301911	5-D9	EI-343373	3-IC5	ER-672816	4-R1B	EW-346251	6-3E
ED-301911	5-D2	EI-343417	5-IC3	ES-336780	5-SW16	EW-349427	6-3C
ED-301911	5-D10	EI-343417	5-IC4	ES-336780	5-SW10	EW-374894	6-3U
ED-301911	5-D6	EI-344764	3-IC1	ES-336780	5-SW14	EZ-631945	6-4

A1007A

Pin No.	Functions	Pin No.	Functions	
1	DIGIT 0	29	CARTRIDGE (MM/MC) SELECTION INPUT MC → "H" MM → "L"	
2	DIGIT 1			
3	DIGIT 2			
4	DIGIT 3			
5	DIGIT 4			
6	DIGIT 5			
	} STROBE FOR KEY MATRIX CONVERTER FL DISPLAY	30	TEST	
		31	X <sub>IN</sub>	
		32	X <sub>OUT</sub>	
		33	RESET INPUT	
7		SEG 12	34	HOLD INPUT (BACK UP)
8		SEG 13	35	INPUT STATUS OUTPUT, TUNER → "L" PHONO/CD → "H"
9	SEG 11			
10	SEG 10	36	TUNER OPERATION PULSE INPUT, Switching input selector to TUNER whenever receives the pulse (6 m sec) from Tuner MI-COM (IC A1007T)	
11	SEG 9			
12	SEG 8			
13	INPUT SELECTOR DATA FOR ANALOGUE SW			
	} FL DISPLAY SEGMENT DRIVE	37	MM/MC CIRCUIT SWITCHING OUTPUT.	
14		INPUT SELECTOR CLOCK FOR ANALOGUE SW	38	DATA DETECTION FROM A/D CONVERTER
15		INPUT SELECTOR STROBE FOR ANALOGUE SW	39	END DETECTION FROM A/D CONVERTER
16	STROBE FOR ELECTRONIC VOLUME (MAIN, BASS, TREBLE VOLUME)	40	ST-WR (CONVERSION START) OUTPUT FOR A/D CONVERTER (LC-7910) DATA OUTPUT FOR MAIN, BASS, TREBLE CONTROL VOLUME IC (TC9176P, TC9156P × 2)	
17	SEG 7			
18	SEG 6			
19	SEG 5			
20	SEG 4			
21	GND	41	CE (DATA CLOCK) OUTPUT FOR A/D CONVERTER (LC7910) CLOCK OUTPUT FOR MAIN, BASS TREBLE, CONTROL VOLUME IC (IC9176P, TC9150P × 2)	
22	SEG 3			
23	SEG 2			
24	SEG 1			
25	SEG 0			
26	} KEY MATRIX INPUT	42	VDD +5V	
27				
28				



---

# AKAI

## AA-A25/Y1 MODEL AA-A25L

### TABLE OF CONTENTS

1. SCHEMATIC DIAGRAM OF ICs .....	2
2. CONTROL BLOCK DIAGRAM AA-A25/L .....	6
3. TUNER BLOCK DIAGRAM AA-A25/L .....	7
4. CONNECTION DIAGRAM AA-A25/L .....	8
5. MAIN AMP PC BOARD, CONTROL (B) PC BOARD AND OTHERS AA-A25/L ...	9
6. CONTROL (A) SCHEMATIC DIAGRAM AA-A25/L .....	10
7. CONTROL (A) PC BOARD AA-A25/L .....	11
8. TUNER SCHEMATIC DIAGRAM AA-A25 .....	12
9. TUNER PC BOARD AA-A25 .....	13
10. TUNER SCHEMATIC DIAGRAM AA-A25L .....	14
11. TUNER PC BOARD AA-A25L .....	15
12. PRE AMP SCHEMATIC DIAGRAM AA-A25/L .....	16
13. PRE AMP PC BOARD AA-A25/L .....	17
14. MPX SCHEMATIC DIAGRAM AA-A25/L .....	18
15. MPX PC BOARD AA-A25/L .....	18
16. FRONT END SCHEMATIC DIAGRAM AA-A25/L .....	18
17. FRONT END PC BOARD AA-A25/L .....	18

LA3390

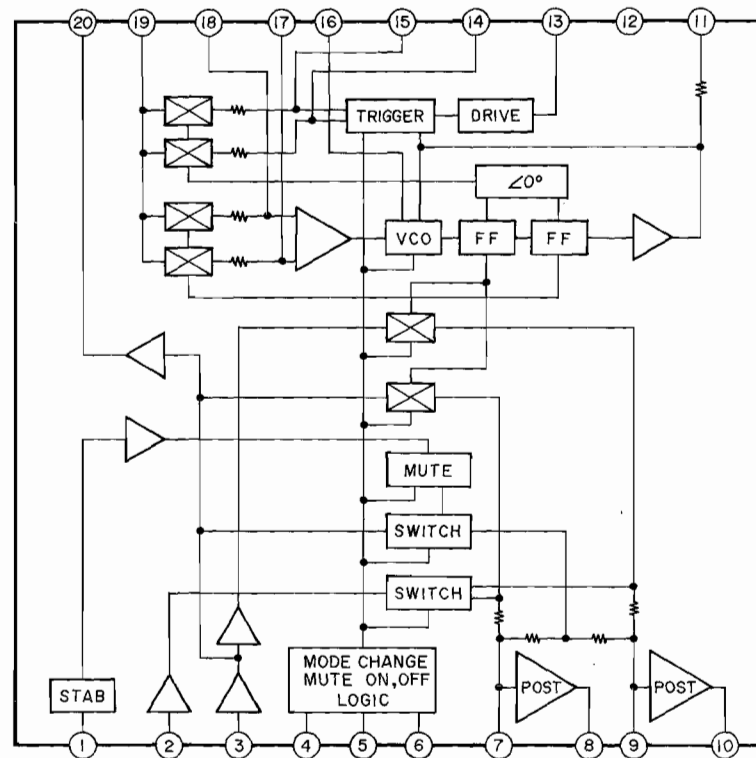

TC9125BP

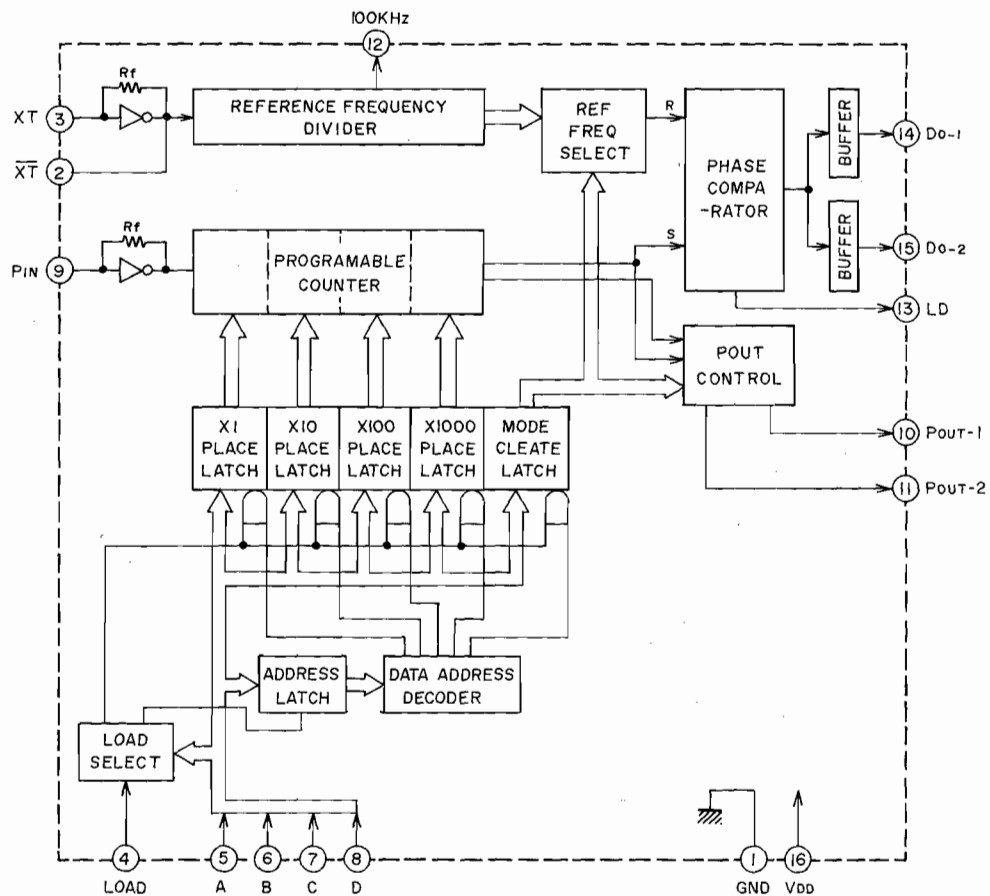

# A1007T

Pin No.	Functions	Pin No.	Functions
1	NOT USED	17	SEG e
2	TUNER OPERATION PULSE OUTPUT, Output 6 msec pulse to switch the input selector of Amp MI-COM (A1007A) to Tuner when operating Tuner section by depressing BAND, TUNER UP/DOWN or PRESET CH buttons.	18	SEG f
		19	SEG g
		20	SEG n
		21	GND
3	DIGIT 0 } DIGIT 1 } DIGIT 2 } STROBE FOR KEY DIGIT 3 } MATRIX CONVERTER DIGIT 4 } & FL DISPLAY DIGIT 5 }	22	A
		23	B
		24	C
		25	D
		26	KEY MATRIX INPUT and AREA JUDGEMENT INPUT
27			
28			
9	SEG a } SEG b } FL DISPLAY SEG c } SEGMENT DRIVE SEG d }	29	
		30	GND
		31	X <sub>IN</sub>
		32	X <sub>OUT</sub>
10		33	RESET INPUT
11		34	HOLD INPUT (BACK UP)
12		35	DETECTOR INPUT FOR THE PRESET CH NUMBER, 20CH → "L", 16CH → "H"
13	FM MODE SELECTOR OUTPUT FORCED MONO → "H"	36	FM Band Designation Output
14	TUNER OUT (L & R) MUTE OUTPUT, MUTE at "L"	37	MW Band Designation Output
		38	LW Band Designation Output
		39	LOAD OUTPUT TERMINAL to PLL IC (T9125BP)
		40	DETECTOR INPUT FOR THE AUTO STOP AT SCAN MODE
15	DETECTOR INPUT FOR THE STATUS OF AMP SECTION MI-COM (A1007A) INPUT SELECTOR. PHONO/CD → "H", TUNER → "L"	41	Not used and Connect to +B LINE
		42	VDD (+5V)
		43	
		44	
16	Becomes level "H" 1 second after power is turned on ("H" after Reset/Back up cancellation) For the models AA-A35/A45, this terminal is used for the synchronization between static display (Bar meter) and Dynamic display when power is turned on.	45	
		46	
		47	
		48	

# M5218P, M5218P-21, M5220L

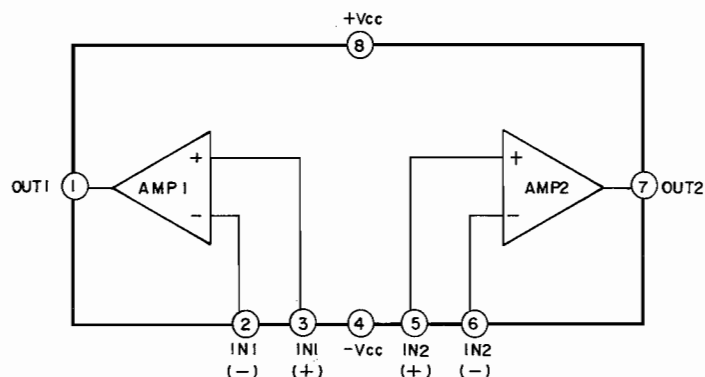

TC9156P

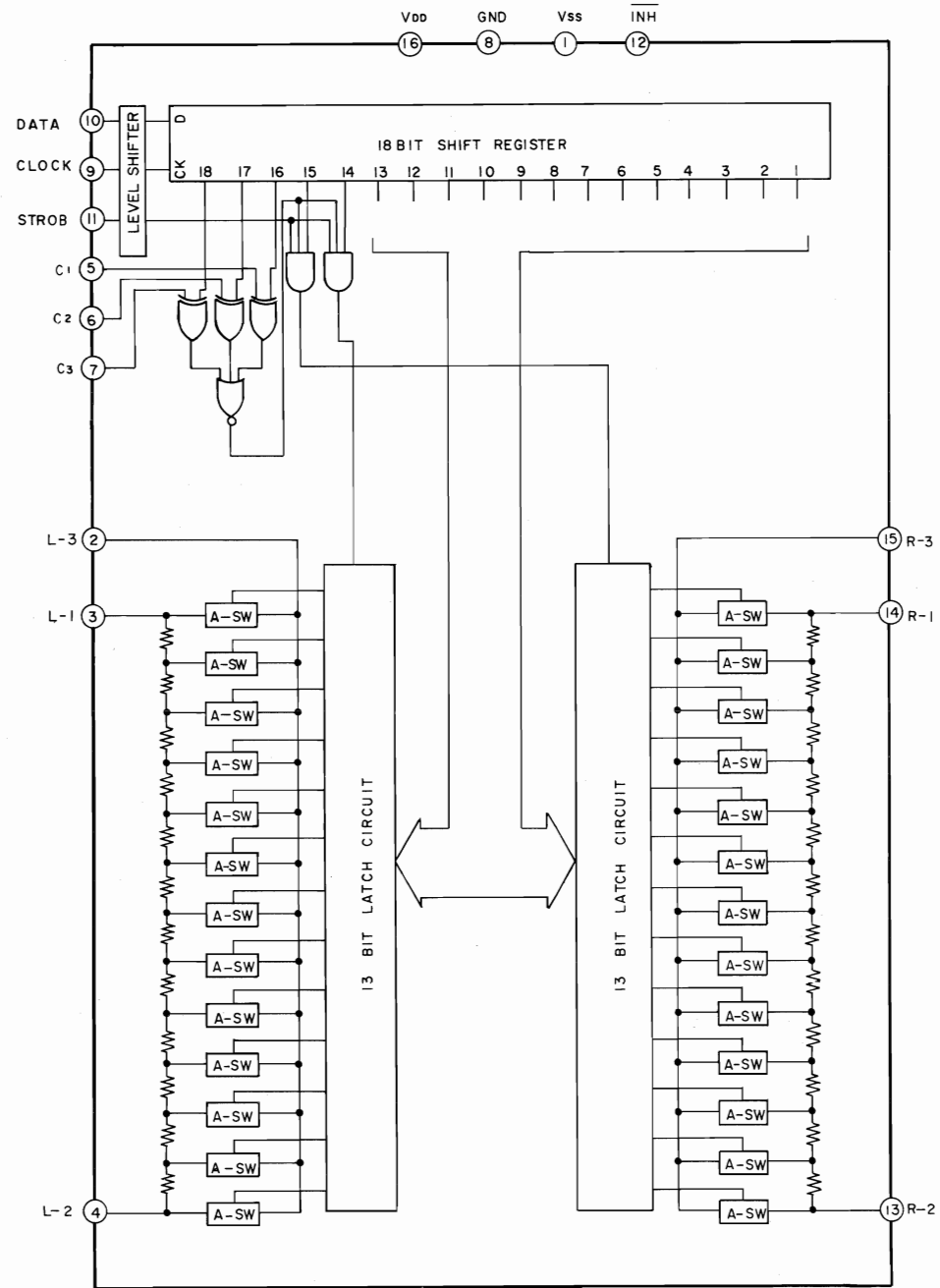

STK4833

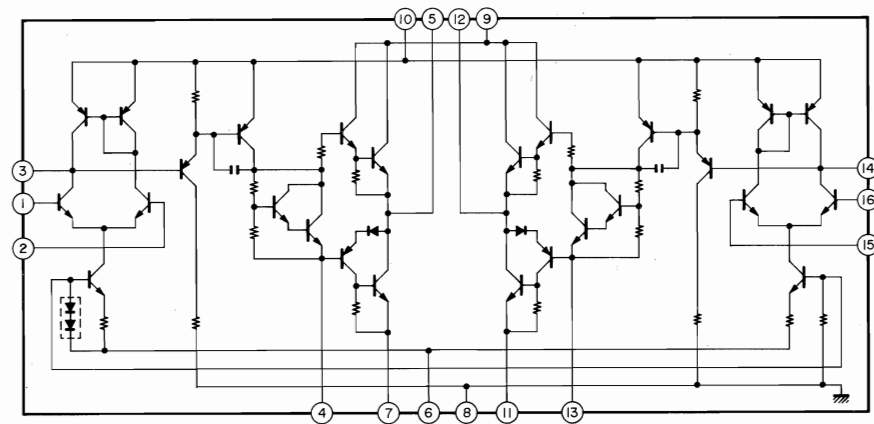

TC9176

Pin No.	Symbol	Functions	Remarks
1	V <sub>SS</sub>	-15V	
2	L-OUT <sub>1</sub>	10dB STEPS ATTENUATOR OUTPUT (Lch) Audio signal attenuate 0 to 70dB (10dB steps)	
3	L-IN <sub>1</sub>	10 dB STEPS ATTENUATOR INPUT (Lch)	
4	A-GND	AC GND (Lch)	
5	L-IN <sub>2</sub>	2dB STEPS ATTENUATOR INPUT (Lch)	
6	L-OUT <sub>2</sub>	2dB STEPS ATTENUATOR OUTPUT (Lch) Audio signal attenuate 0 to 8db (2dB steps)	
7	GND	GND	
8	CK	CLOCK INPUT, This terminal is the CLOCK INPUT to read data of the DATA terminal.	
9	DATA	DATA INPUT FOR THE ATTENUATION LEVEL AND CHANNEL (Lch and Rch) SELECTION DATA, Data is composed to 20 bits and input by clock signal.	
10	ST	STROBE INPUT Attenuation Levels and channel (Lch and Rch) selection are read DATA, CK terminal that is latch to activate "H" at this terminal. Holding the previous data, when "H" level doesn't apply to this terminal.	
11	R-OUT <sub>2</sub>	2dB STEPS ATTENUATOR OUTPUT (Rch) Audio signal attenuate 0 to 8dB (2dB steps)	
12	R-IN <sub>2</sub>	2dB STEPS ATTENUATOR INPUT (Rch)	
13	A-GND	AC GND (Rch)	
14	R-IN <sub>1</sub>	10dB STEPS ATTENUATOR INPUT (Rch)	
15	R-OUT <sub>1</sub>	10dB STEPS ATTENUATOR OUTPUT (Rch) Audio signal attenuate 0 to 70dB (10dB steps)	
16	V <sub>DD</sub>	+15V	

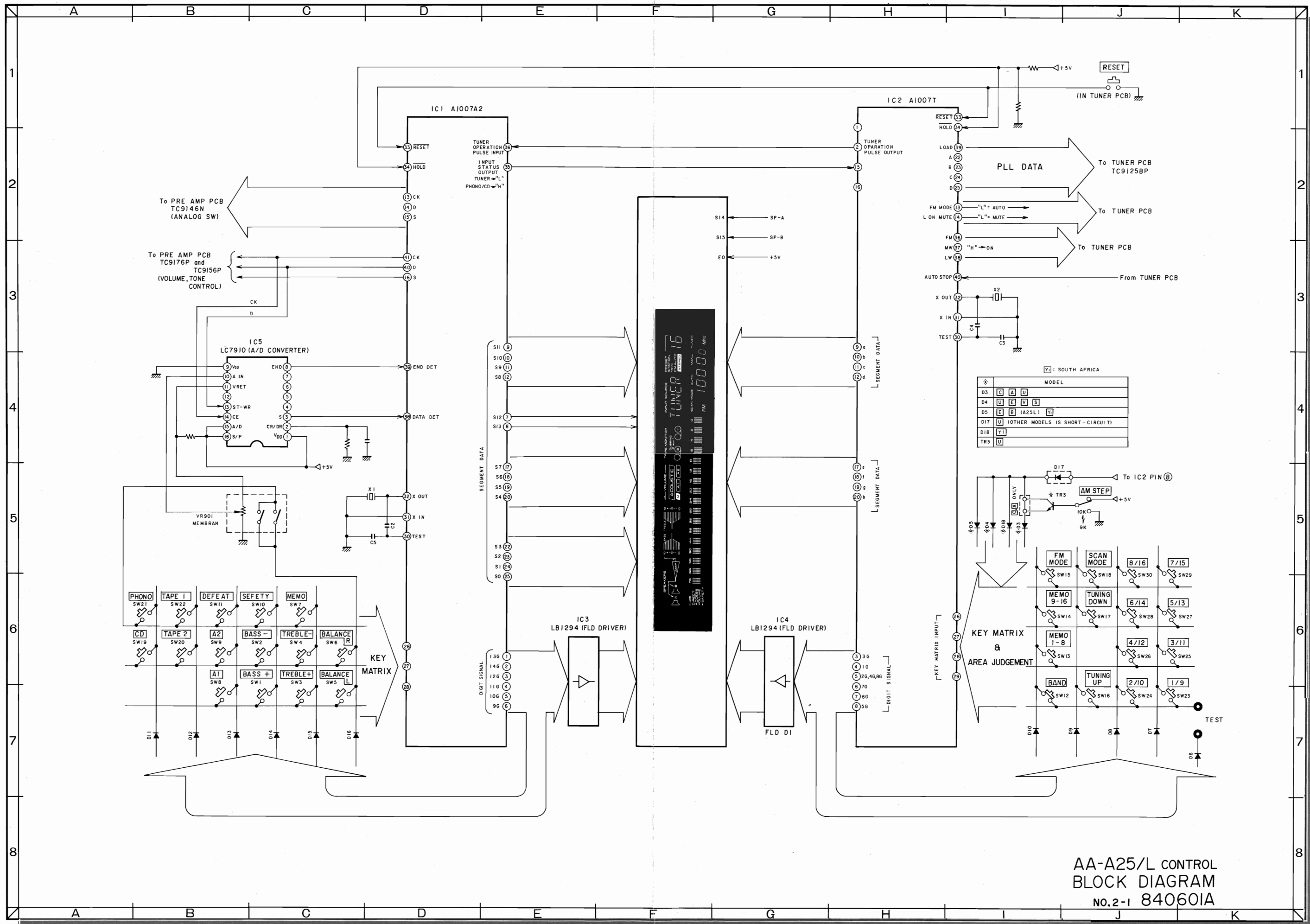

Y: SOUTH AFRICA

MODEL			
D3	C	A	U
D4	U	E	V
D5	E	B	(A25L) Y
D17	U (OTHER MODELS IS SHORT-CIRCUIT)		
D18	Y		
TR3	U		

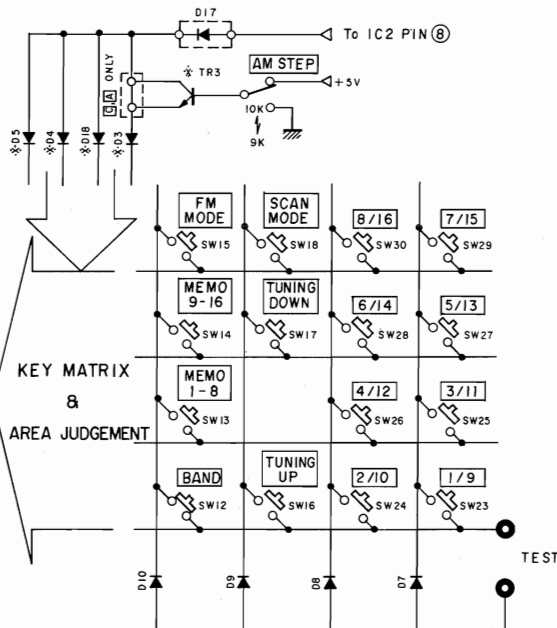

AA-A25/L CONTROL  
BLOCK DIAGRAM  
NO.2-1 84060IA



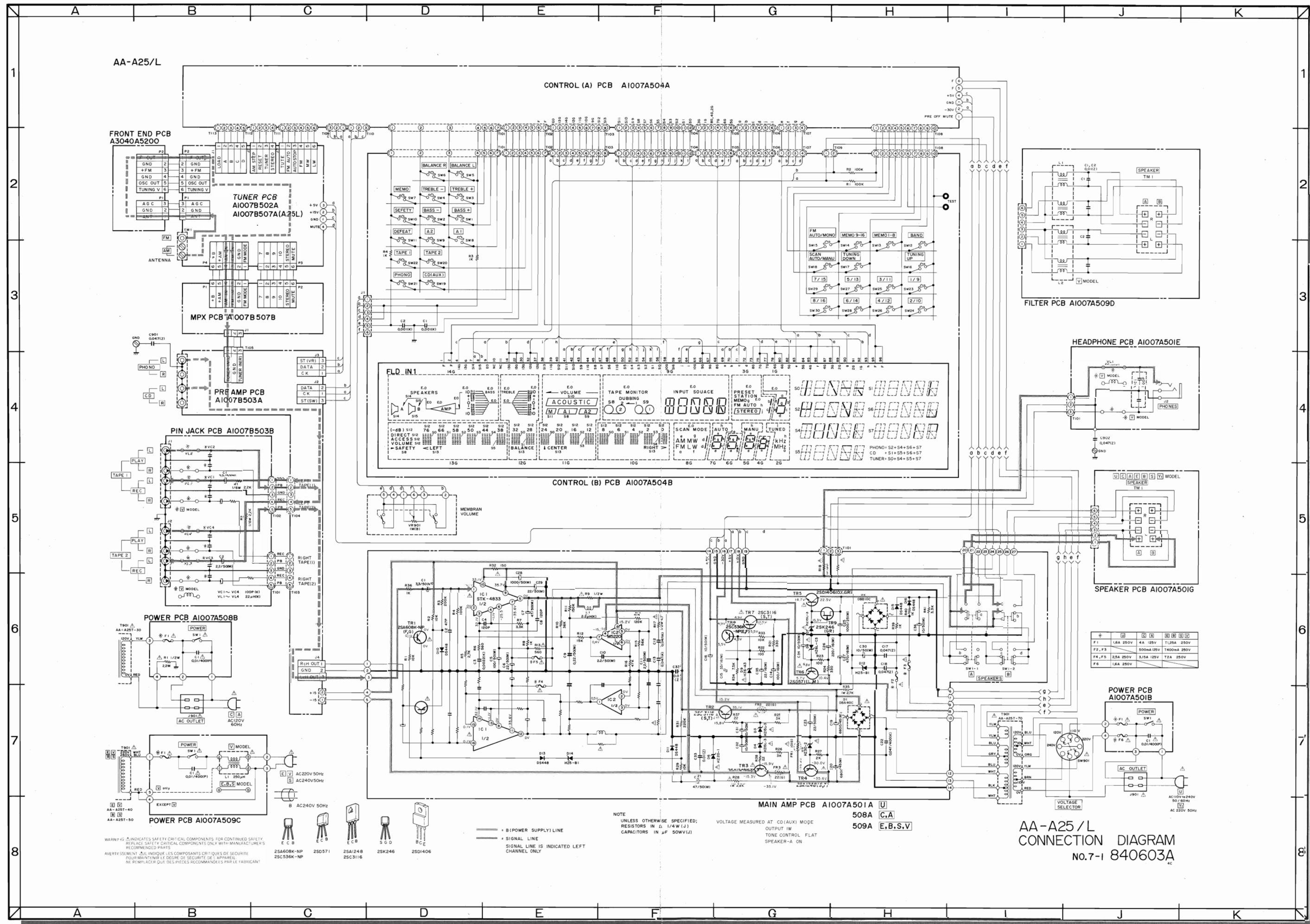

AA-A25/L

CONTROL (A) PCB A1007A504A

FRONT END PCB A3040A5200

TUNER PCB A1007B502A A1007B507A(A25L)

MPX PCB A1007B507B

PRE AMP PCB A1007B503A

PIN JACK PCB A1007B503B

POWER PCB A1007A508B

POWER PCB A1007A509C

CONTROL (B) PCB A1007A504B

MAIN AMP PCB A1007A501A

FILTER PCB A1007A509D

HEADPHONE PCB A1007A501E

SPEAKER PCB A1007A501G

POWER PCB A1007A501B

WARNING: A INDICATES SAFETY CRITICAL COMPONENTS FOR CONTINUED SAFETY. REPLACE SAFETY CRITICAL COMPONENTS ONLY WITH MANUFACTURER'S RECOMMENDED PARTS.  
 AVERTISSEMENT: AIL INDIQUE LES COMPOSANTS CRITIQUES DE SECURITE. REMPLACEZ SEULEMENT LES COMPOSANTS CRITIQUES DE SECURITE DE L'APPAREIL NE REMPLACEZ QUE DES PIECES RECOMMANDEES PAR LE FABRICANT.

25A06R-NP 25C536K-NP

25D571

25A1248

25C3116

25K246

25D1406

NOTE: UNLESS OTHERWISE SPECIFIED, RESISTORS IN  $\Omega$ , 1/4W (J), CAPACITORS IN  $\mu$ F 50WV(U)

VOLTAGE MEASURED AT CD(AUX) MODE OUTPUT IN TONE CONTROL FLAT SPEAKER-A ON

508A C.A.  
509A E.B.S.V.

AA-A25/L CONNECTION DIAGRAM No.7-1 840603A

4C





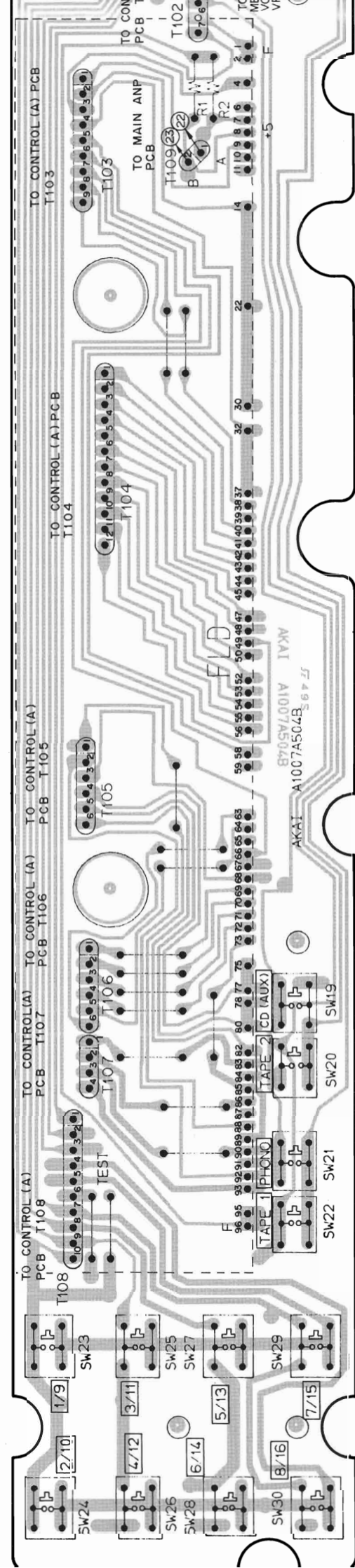

CONTROL (B) PCB A1007A504B

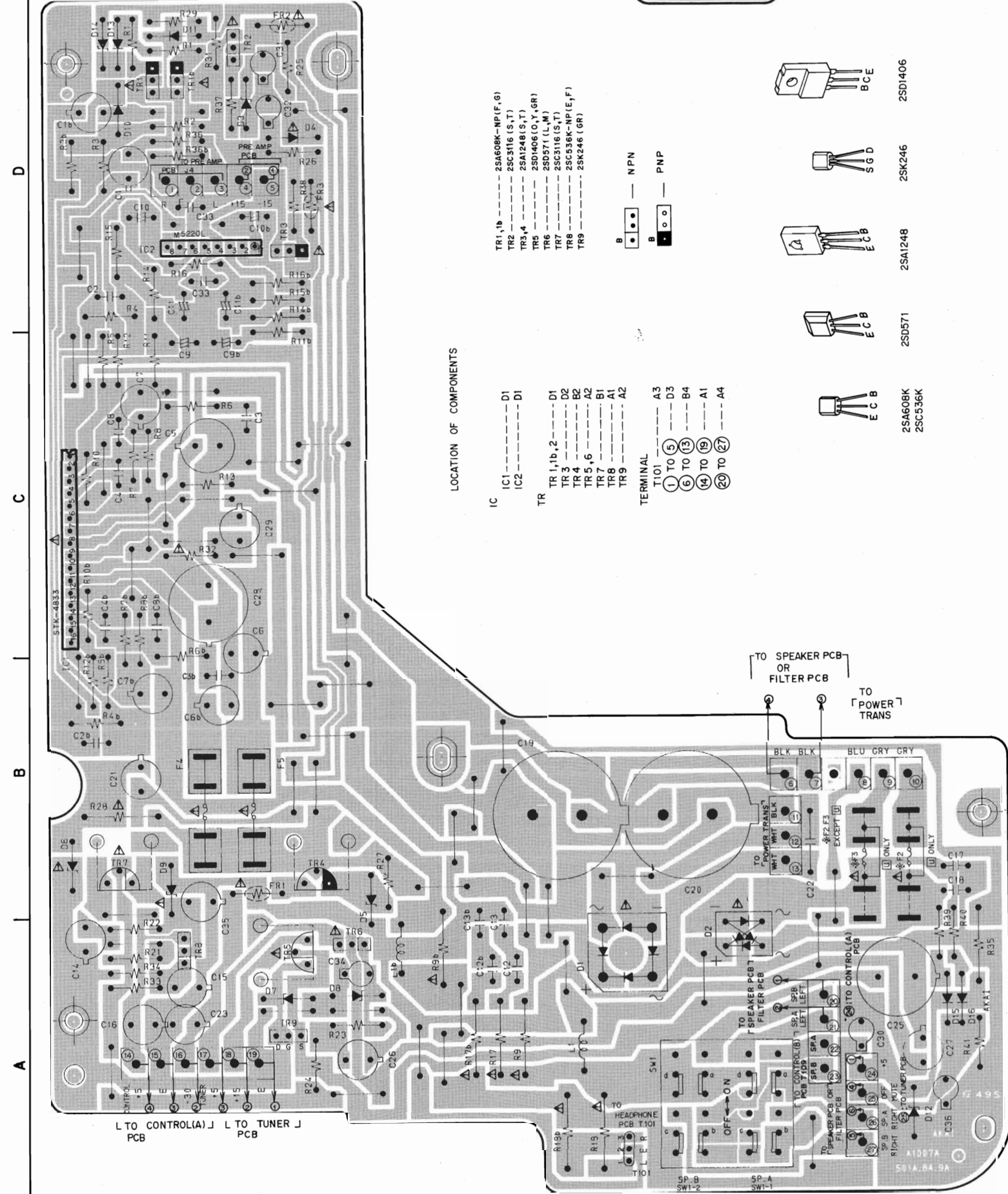

LOCATION OF COMPONENTS

- IC  
IC1 --- D1  
IC2 --- D1
- TR  
TR 1,1b,2 --- D1  
TR 3 --- D2  
TR 4 --- B2  
TR 5,6 --- A2  
TR 7 --- B1  
TR 8 --- A1  
TR 9 --- A2
- TERMINAL  
T101 --- A3  
1 TO 5 --- D3  
6 TO 13 --- B4  
14 TO 18 --- A1  
20 TO 27 --- A4

- TR 1,1b --- 2SA608K-NP(F,G)  
TR 2 --- 2SC316 (S,T)  
TR 3,4 --- 2SA1248 (S,T)  
TR 5 --- 2SD1406 (O,Y,GR)  
TR 6 --- 2SD571 (L,M)  
TR 7 --- 2SC3116 (S,T)  
TR 8 --- 2SC536K-NP (E,F)  
TR 9 --- 2SK246 (GR)

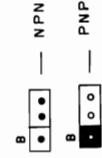

- E C B  
E C B  
E C B  
E C B  
E C B
- 2SA608K  
2SC536K
- 2SD571  
2SA1248
- 2SK246  
2SD1406
- B C E  
S G D

MAIN AMP PCB A1007A501A 508A 509A

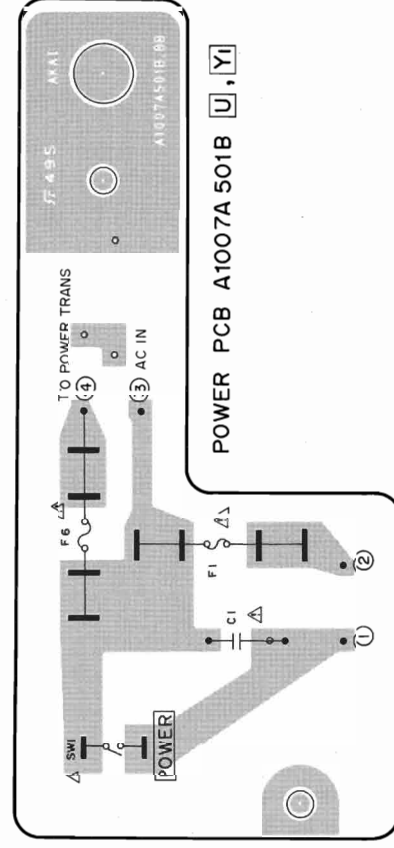

WARNING: Δ INDICATES SAFETY CRITICAL COMPONENTS FOR CONTINUED SAFETY. REPLACE SAFETY CRITICAL COMPONENTS ONLY WITH MANUFACTURER'S RECOMMENDED PARTS.  
AVERTISSEMENT: Δ IL INDIQUE LES COMPOSANTS CRITIQUES DE SÉCURITÉ. POUR MAINTENIR LE DEGRÉ DE SÉCURITÉ DE L'APPAREIL, NE REMPLACER QUE DES PIÈCES RECOMMANDÉES PAR LE FABRICANT.

PIN JACK PCB A100

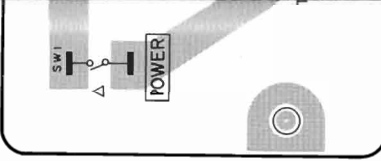
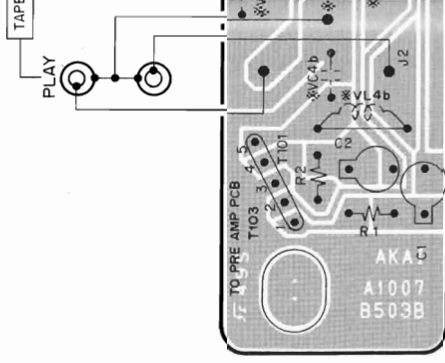

1 2 3 4 5 6 7 8

F G H J K

MODEL	K
D 4 U, E, V, S	
D 5 L, E, B (AA 225L), Y	
D 3 C, A, U	
D 18 V	
D 17 U	

Y = SOUTH AFRICA

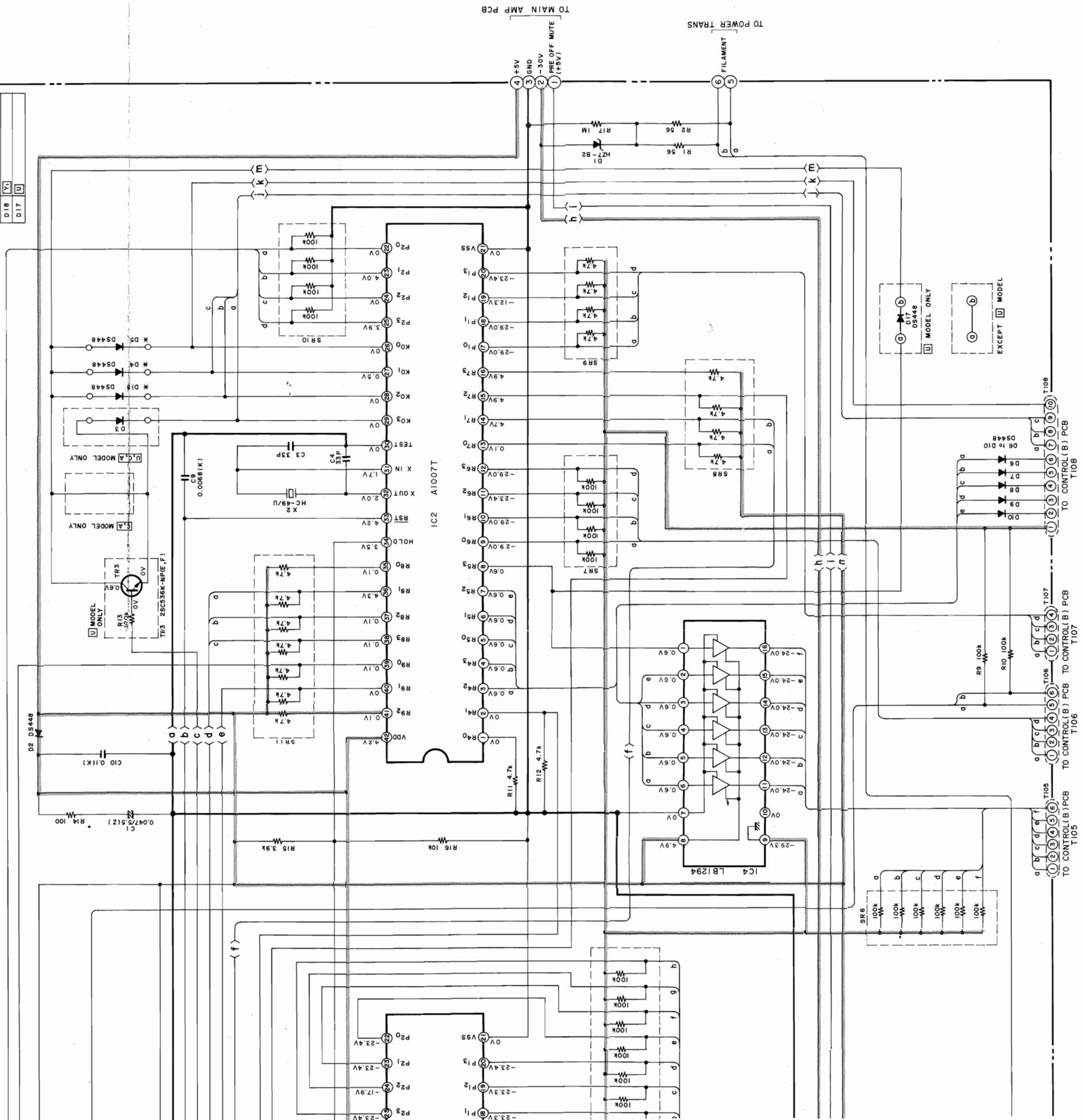

NOTE  
UNLESS OTHERWISE SPECIFIED  
ALL RESISTORS IN OHMS 1/6W(J)  
ALL CAPACITORS IN  $\mu$ F 50 WV(J)

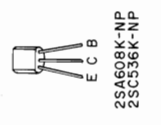

AA-A25/L  
CONTROL (A)  
SCHEMATIC DIAGRAM  
NO. 7-2 840604A<sub>3c</sub>

F G H J K



	TR3	D3	D4	D5	D17	R13	D18
U	○	○	○	/	○	○	/
C,A	/	○	/	/	/	/	/
E,V,S	/	/	○	/	/	/	/
A25L	/	/	/	○	/	/	/
Y1	/	/	/	○	/	/	○

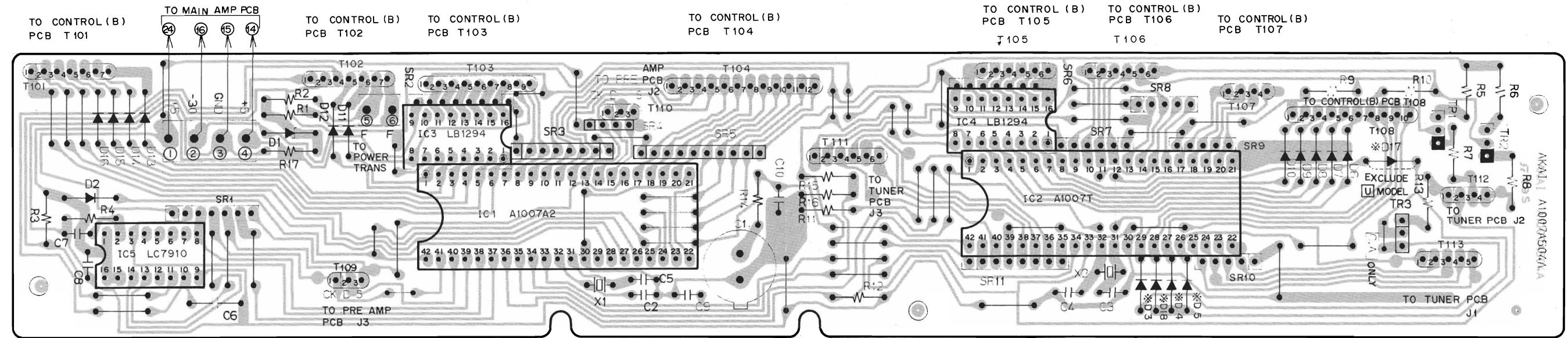

TR 1,2 ---- 2SA608K-NP (E,F,G)  
 TR 3 ---- 2SC536K-NP (E,F)

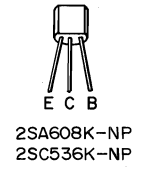

CONTROL (A) PCB A1007A504A



AA-A25

TUNER PCB A1007B502A

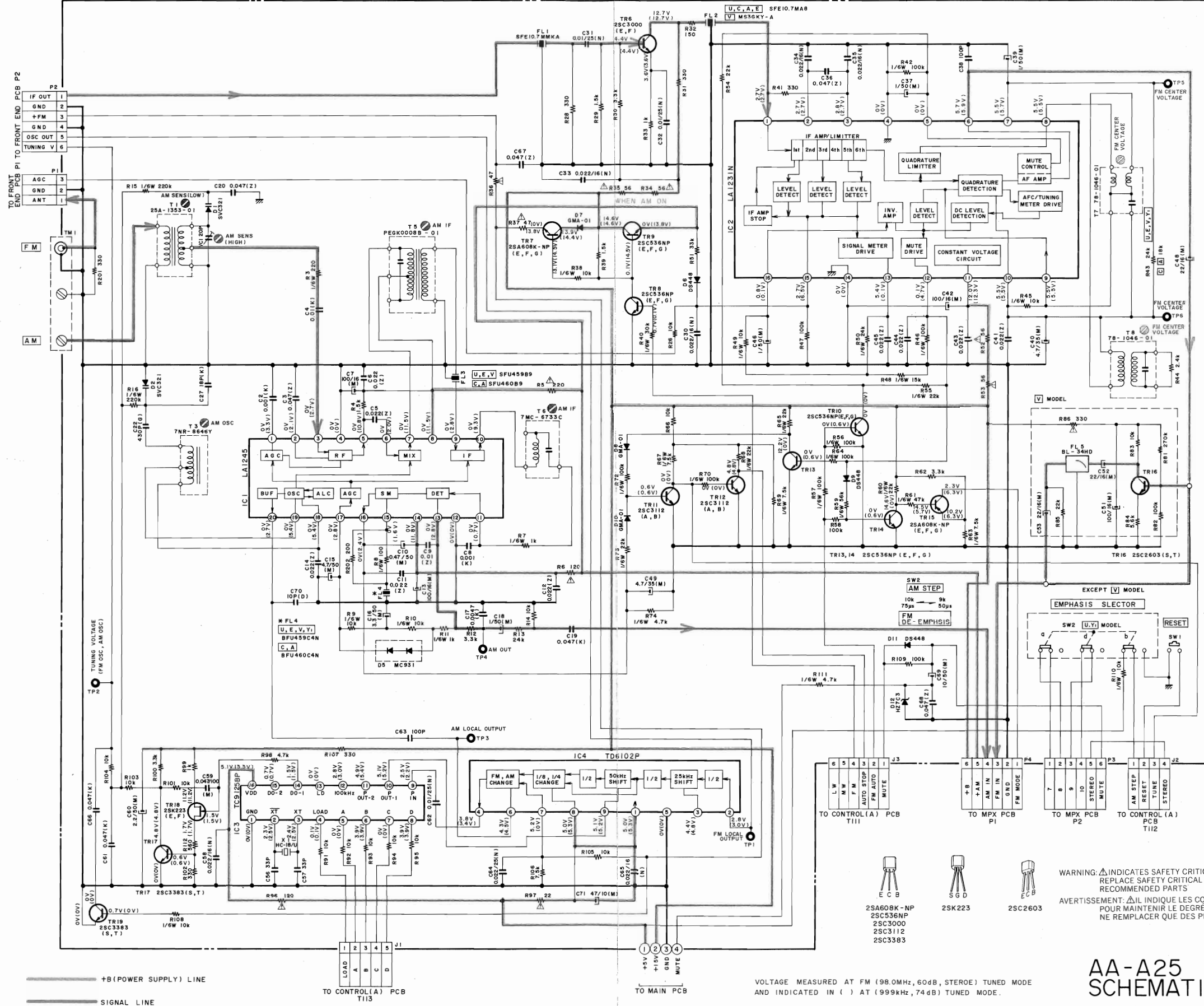

[V] = SOUTH AFRICA

NOTE  
 UNLESS OTHERWISE SPECIFIED  
 ALL RESISTORS IN OHMS 1/4W(J)  
 ALL CAPACITORS IN μF 50WV(J)

WARNING: Δ INDICATES SAFETY CRITICAL COMPONENTS. FOR CONTINUED SAFETY, REPLACE SAFETY CRITICAL COMPONENTS ONLY WITH MANUFACTURER'S RECOMMENDED PARTS.  
 AVERTISSEMENT: Δ IL INDIQUE LES COMPOSANTS CRITIQUES DE SÉCURITÉ. POUR MAINTENIR LE DEGRÉ DE SÉCURITÉ DE L'APPAREIL, NE REMPLACER QUE DES PIÈCES RECOMMANDÉES PAR LE FABRICANT.

- 2SA608K-NP
- 2SC536NP
- 2SC3000
- 2SC3112
- 2SC3383
- SGD
- 2SK223
- 2SC2603

VOLTAGE MEASURED AT FM (98.0MHz, 60dB, STEREO) TUNED MODE AND INDICATED IN ( ) AT (99.9kHz, 74dB) TUNED MODE.

AA-A25 TUNER  
 SCHEMATIC DIAGRAM  
 NO.7-3 840605A<sub>4c</sub>

ADJUSTMENT ITEM	POINT
AM SENS (HIGH)	VC1
AM SENS (LOW)	T1
AM OSC	T3
AM IF	T5,T6
FM CENTER VOLTAGE	T7,T8
FM LOCAL OUTPUT	TP1
TUNING VOLTAGE (FM, AM OSC)	TP2
AM LOCAL OUTPUT	TP3
AM OUT PUT	TP4
FM CENTER VOLTAGE	TP5,6

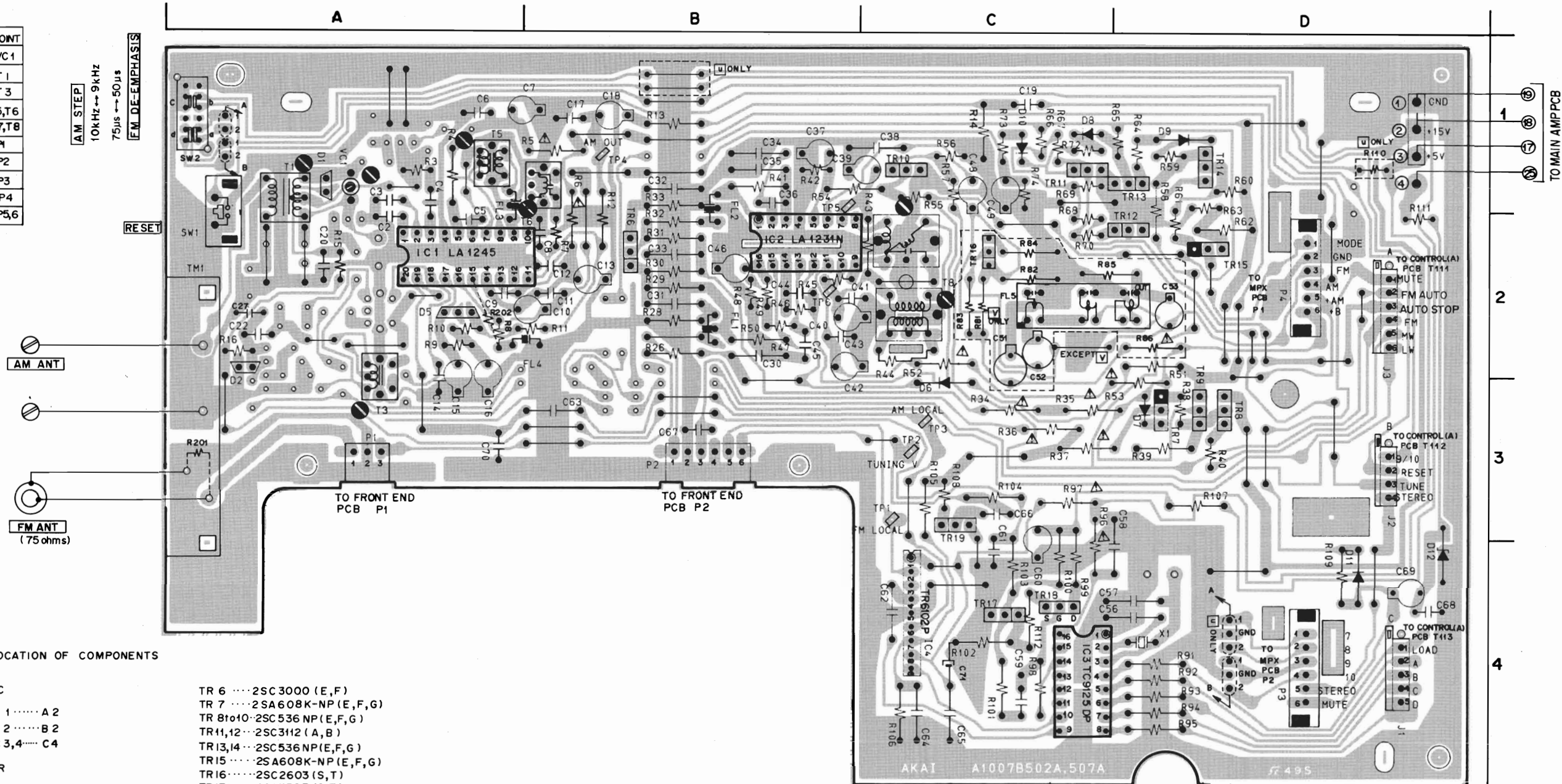

LOCATION OF COMPONENTS

IC

- IC 1..... A 2
- IC 2..... B 2
- IC 3,4..... C 4

TR

- TR 6..... B 2
- TR 7 to 9... D 3
- TR 10,11... C 1
- TR 12..... D 2
- TR 13,14... D 1
- TR 15..... D 2
- TR 16..... C 2
- TR 17,18... C 4
- TR 19..... C 3

TERMINAL

- P1..... A 3
- P2..... B 3
- P3..... D 4
- P4..... D 2
- J1..... D 4
- J2..... D 3
- J3..... D 2
- ①,④... D 1

- TR 6 ..... 2SC3000 (E,F)
- TR 7 ..... 2SA608K-NP (E,F,G)
- TR 8 to 10... 2SC536 NP (E,F,G)
- TR 11,12... 2SC3112 (A, B)
- TR 13,14... 2SC536 NP (E,F,G)
- TR 15 ..... 2SA608K-NP (E,F,G)
- TR 16..... 2SC2603 (S,T)
- TR 17..... 2SC3383 (S,T)
- TR 18..... 2SK223 (E)
- TR 19..... 2SC338 (S,T)



- !SA608K.NP
- 2SK223
- 2SC2603
- 2SC536.NP
- 2SC3000
- 2SC3112
- 2SC3383

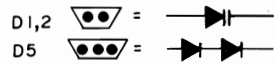
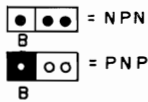

WARNING:  $\Delta$  INDICATES SAFETY CRITICAL COMPONENTS FOR CONTINUED SAFETY. REPLACE SAFETY CRITICAL COMPONENTS ONLY WITH MANUFACTURER'S RECOMMENDED PARTS  
 AVERTISSEMENT:  $\Delta$  IL INDIQUE LES COMPOSANTS CRITIQUES DE SÉCURITÉ. POUR MAINTENIR LE DEGRÉ DE SÉCURITÉ DE L'APPAREIL, NE REMPLACER QUE DES PIÈCES RECOMMANDÉES PAR LE FABRICANT

TUNER PCB AI007B507A

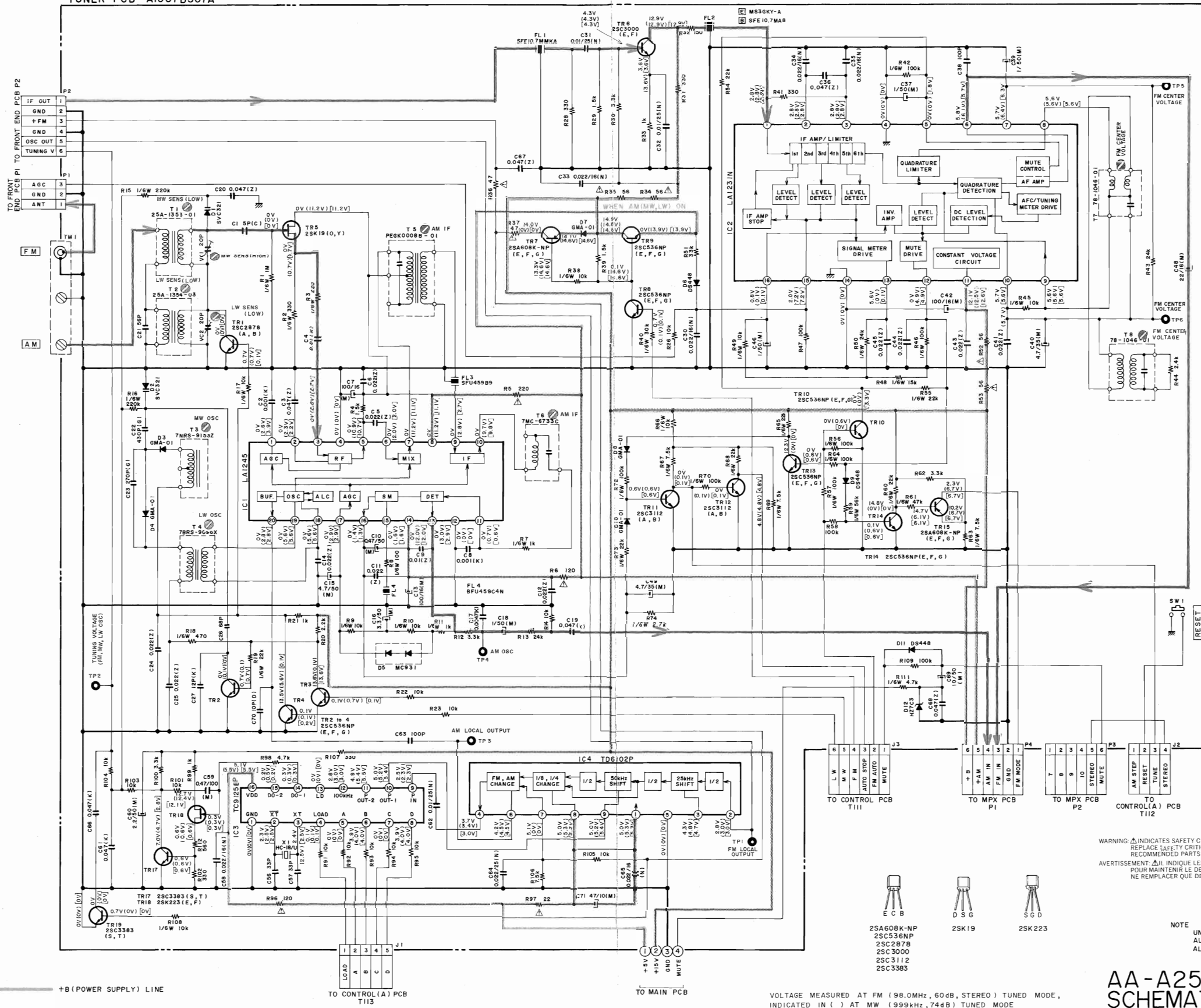

AA-A25L TUNER SCHEMATIC DIAGRAM NO. 7-4 840606A



ADJUSTMENT ITEM	POINT
MW SENS (LOW)	T 1
MW SENS (HIGH)	VC 1
LW SENS (LOW)	T 2
LW SENS (HIGH)	VC 2
LW OSC	T 4
MW OSC	T 3
AM IF	T 5, T 6
FM CENTER VOLTAGE	T 7, T 8
FM LOCAL OUTPUT	TP 1
TUNING VOLTAGE (FM, LW, MW OSC)	TP 2
AM LOCAL OUTPUT	TP 3
AM OUT PUT	TP 4
FM CENTER VOLTAGE	TP 5, 6

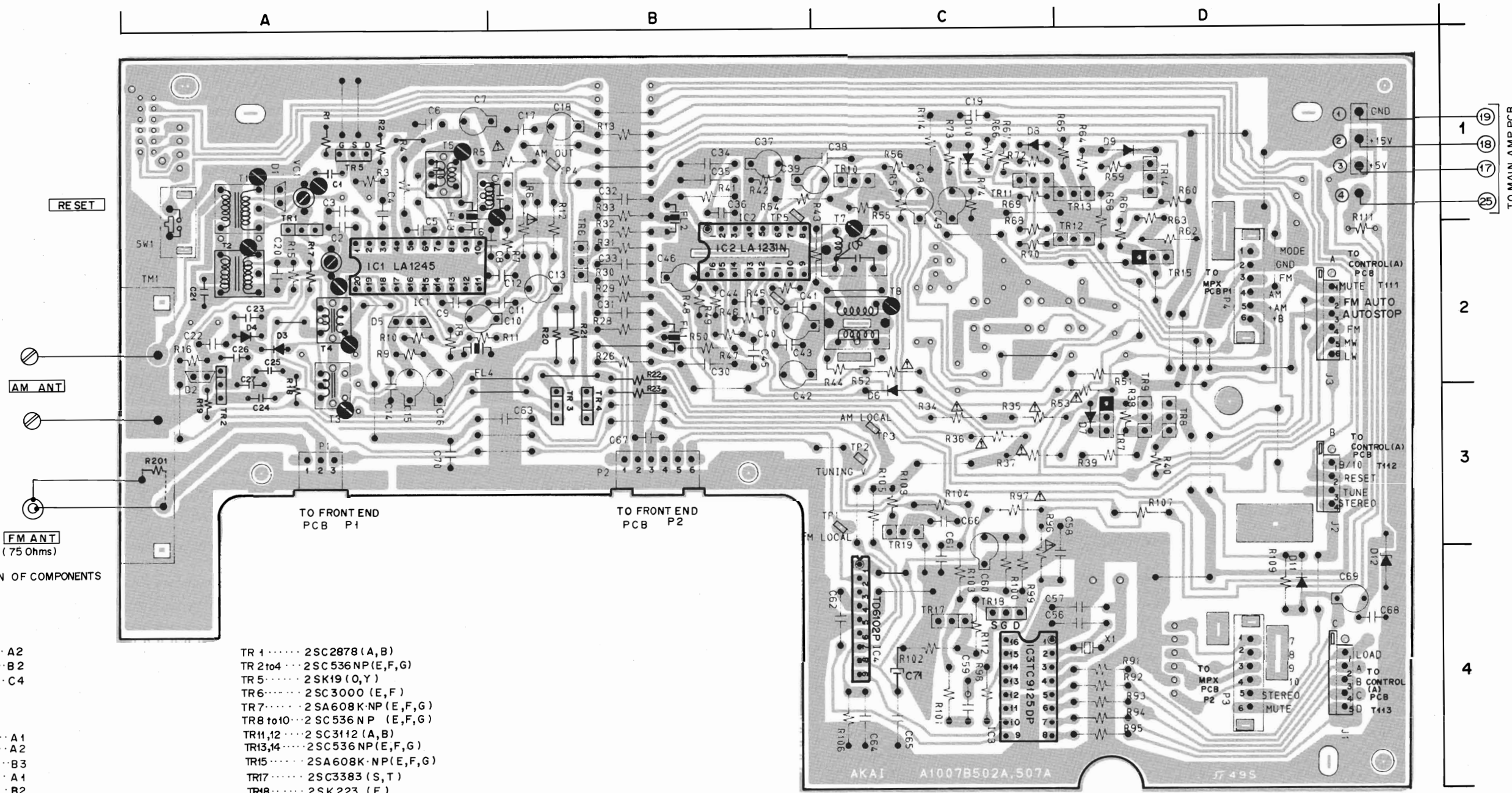

LOCATION OF COMPONENTS

IC

- IC 1.....A2
- IC 2.....B2
- IC 3,4.....C4

TR

- TR 1.....A1
- TR 2.....A2
- TR 3,4.....B3
- TR 5.....A1
- TR 6.....B2
- TR 7 to 9.....D3
- TR 10,11.....C1
- TR 12.....D2
- TR 13,14.....D1
- TR 15.....D2
- TR 17,18.....C4
- TR 19.....C3

TERMINAL

- P1.....A3
- P2.....B3
- P3.....D4
- P4.....D2
- J1.....D4
- J2.....D3
- J3.....D2
- ① to ④.....D1

- TR 1.....2SC2878 (A,B)
- TR 2 to 4.....2SC536NP (E,F,G)
- TR 5.....2SK19 (O,Y)
- TR 6.....2SC3000 (E,F)
- TR 7.....2SA608K-NP (E,F,G)
- TR 8 to 10.....2SC536NP (E,F,G)
- TR 11,12.....2SC3112 (A,B)
- TR 13,14.....2SC536NP (E,F,G)
- TR 15.....2SA608K-NP (E,F,G)
- TR 17.....2SC3383 (S,T)
- TR 18.....2SK223 (E)
- TR 19.....2SC3383 (S,T)

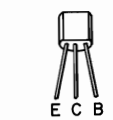

2SA608K-NP  
2SC536NP  
2SC2878  
2SC3000  
2SC3112  
2SC3383



2SK19



2SK223

● ● ● = NPN

● ○ ○ = PNP

D1,2 =

D5 =

WARNING: Δ INDICATES SAFETY CRITICAL COMPONENTS. FOR CONTINUED SAFETY, REPLACE SAFETY CRITICAL COMPONENTS ONLY WITH MANUFACTURER'S RECOMMENDED PARTS.  
AVERTISSEMENT: Δ IL INDIQUE LES COMPOSANTS CRITIQUES DE SÉCURITÉ. POUR MAINTENIR LE DEGRÉ DE SÉCURITÉ DE L'APPAREIL, NE REMPLACER QUE DES PIÈCES RECOMMANDÉES PAR LE FABRICANT.



AA-A25/L

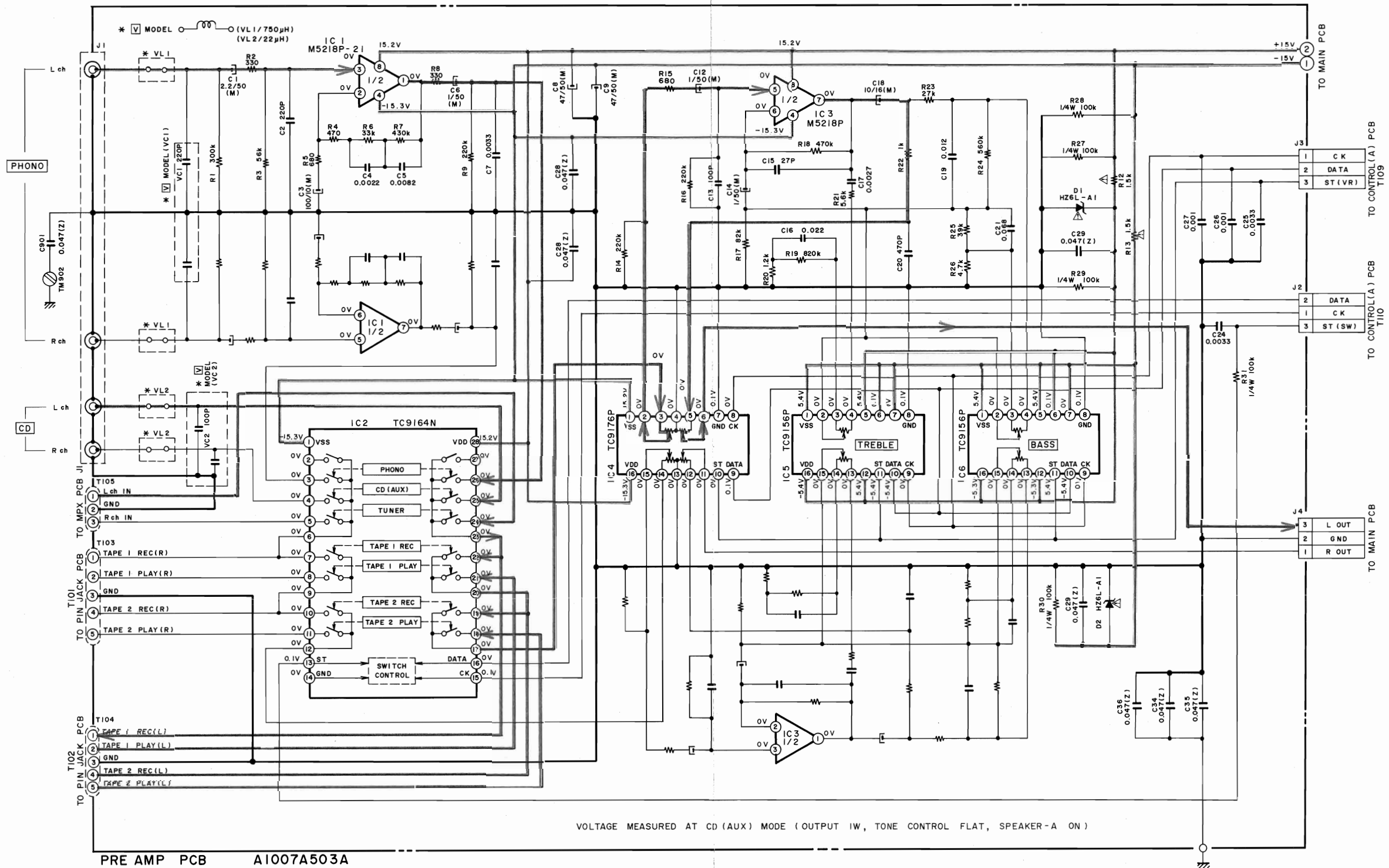

PRE AMP PCB A1007A503A

VOLTAGE MEASURED AT CD (AUX) MODE (OUTPUT 1W, TONE CONTROL FLAT, SPEAKER - A ON)

--- +B (POWER SUPPLY) LINE  
 --- SIGNAL LINE  
 --- SIGNAL LINE IS INDICATED LEFT CHANNEL ONLY.

WARNING: ⚠ INDICATES SAFETY CRITICAL COMPONENTS FOR CONTINUED SAFETY. REPLACE SAFETY CRITICAL COMPONENTS ONLY WITH MANUFACTURER'S RECOMMENDED PARTS.  
 AVERTISSEMENT: ⚠ IL INDIQUE LES COMPOSANTS CRITIQUES DE SÉCURITÉ. POUR MAINTENIR LE DEGRÉ DE SÉCURITÉ DE L'APPAREIL, NE REMPLACER QUE DES PIÈCES RECOMMANDÉES PAR LE FABRICANT.

NOTE  
 UNLESS OTHERWISE SPECIFIED  
 ALL RESISTORS IN OHMS 1/6W(J)  
 ALL CAPACITORS IN µF 50 WV(J)

AA-A25/L PRE AMP  
 SCHEMATIC DIAGRAM  
 NO. 7-5 840607A (A2)

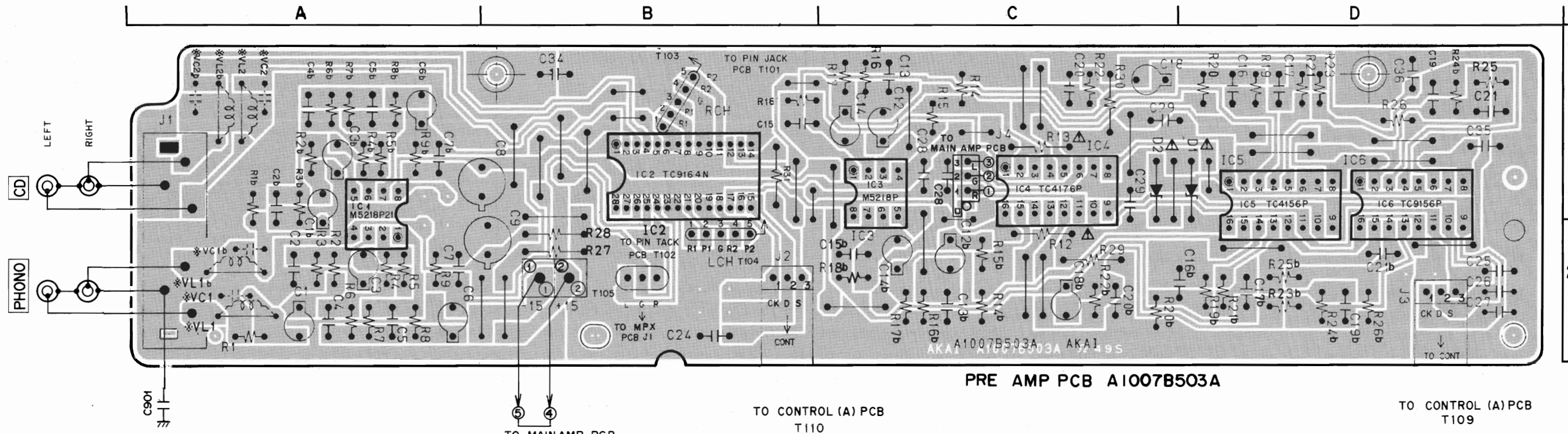

VL1, 1b, 2, 2b }  model only  
 VC1, 1b, 2, 2b }

LOCATION OF COMPONENTS

IC	TERMINAL	
IC1	A1	T103 B1
IC2	B1	T104,105 B2
IC3,4	C1	J2 B2
IC5,6	D1	J3 D2
		J4 C2
		①② B2

WARNING:  $\Delta$  INDICATES SAFETY CRITICAL COMPONENTS. FOR CONTINUED SAFETY, REPLACE SAFETY CRITICAL COMPONENTS ONLY WITH MANUFACTURER'S RECOMMENDED PARTS.  
 AVERTISSEMENT:  $\Delta$  IL INDIQUE LES COMPOSANTS CRITIQUES DE SÉCURITÉ. POUR MAINTENIR LE DEGRÉ DE SÉCURITÉ DE L'APPAREIL, NE REMPLACER QUE DES PIÈCES RECOMMANDÉES PAR LE FABRICANT.

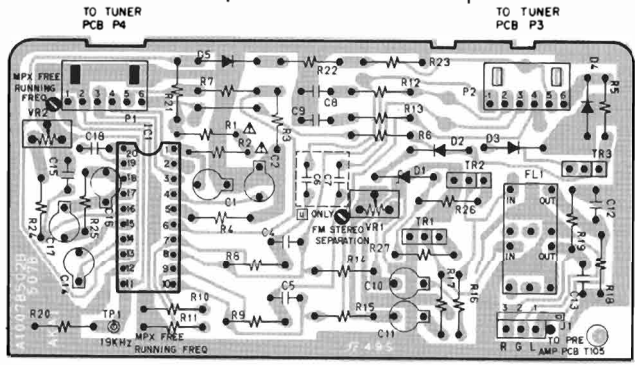

MPX PCB A1007B507B

TR1,2,3 --- 2SC3383(S,T)

□ = NPN

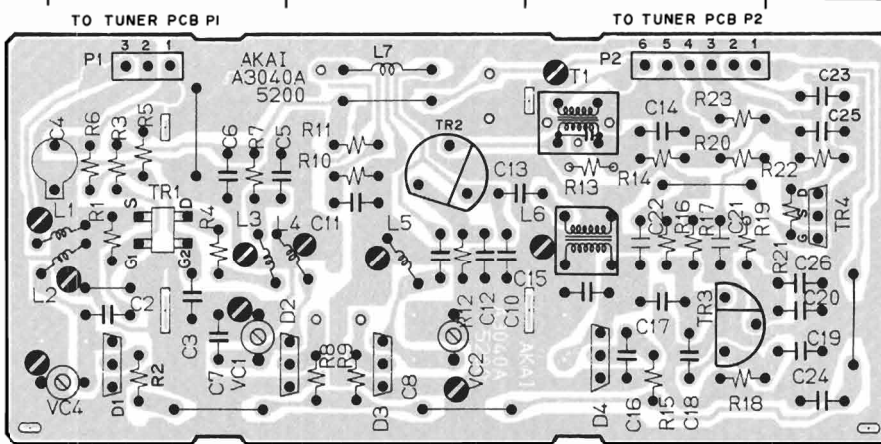

FRONT END PCB A3040C 5200

ADJUSTMENT POINT	
L1 to 5	FM SENS (LOW)
VC1,2,4	FM SENS (HIGH)
L6	FM OSC (LOW)
T1	FM SENS (LOW)
	FM STEREO DISTORTION

TR1-----3SK107 (E)  
 TR2-----2SC2999 (C,D)  
 TR3-----2SC930 (E,F)  
 TR4-----2SK161 (O,Y)

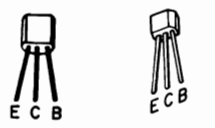
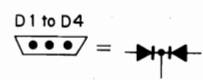

25C930 25C2999

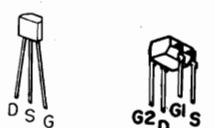

2SK161 3SK107

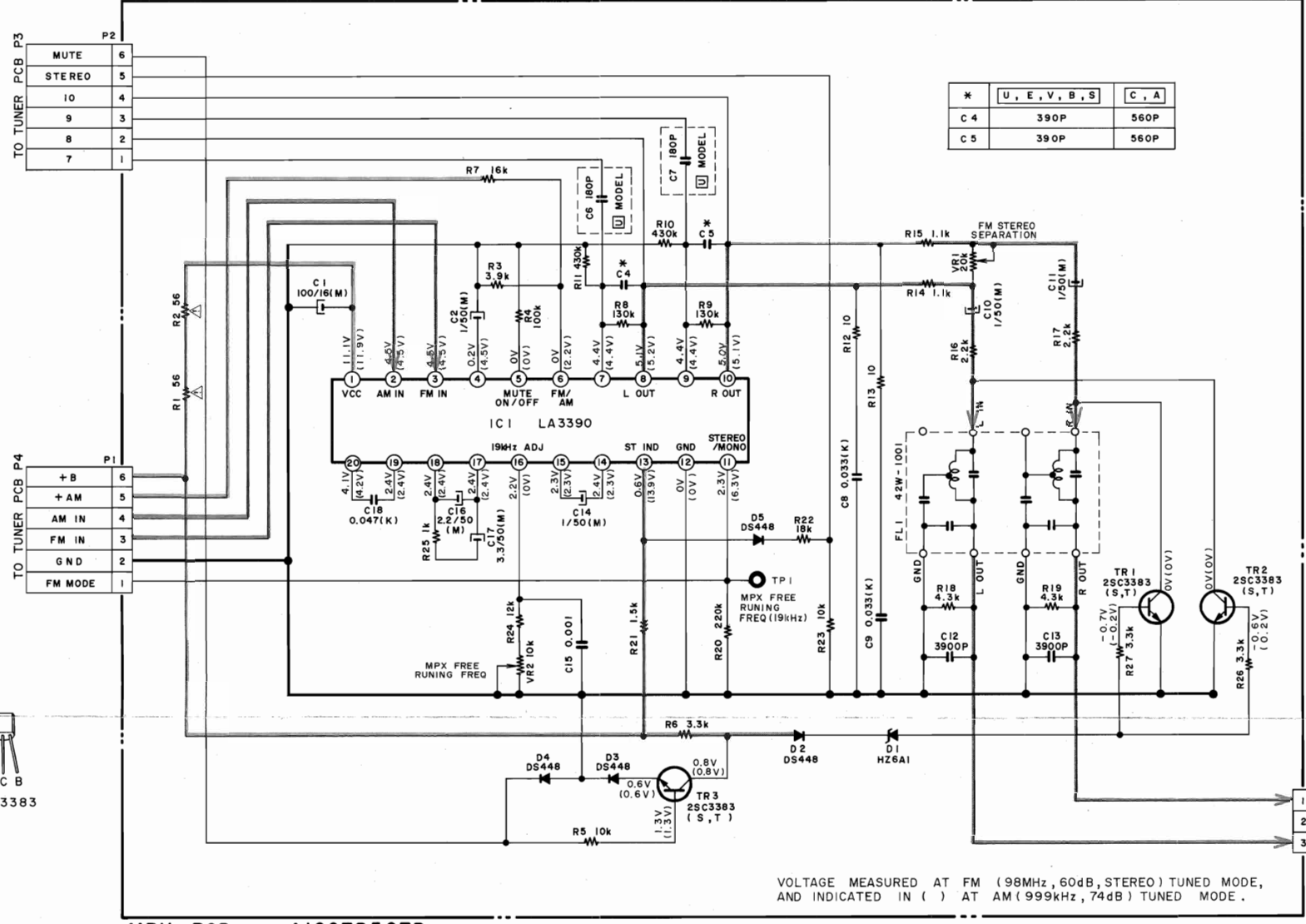

MPX PCB A1007B507B

*	U, E, V, B, S	C, A
C4	390P	560P
C5	390P	560P

VOLTAGE MEASURED AT FM (98MHz, 60dB, STEREO) TUNED MODE, AND INDICATED IN ( ) AT AM (999kHz, 74dB) TUNED MODE.

— +B (POWER SUPPLY) LINE  
 — SIGNAL LINE

NOTE  
 UNLESS OTHERWISE SPECIFIED  
 ALL RESISTORS IN OHMS 1/4W(J)  
 ALL CAPACITORS IN μF 50 WV(J)

AA-A25/L MPX SCHEMATIC DIAGRAM 840608A (A3)

NO. 7-6

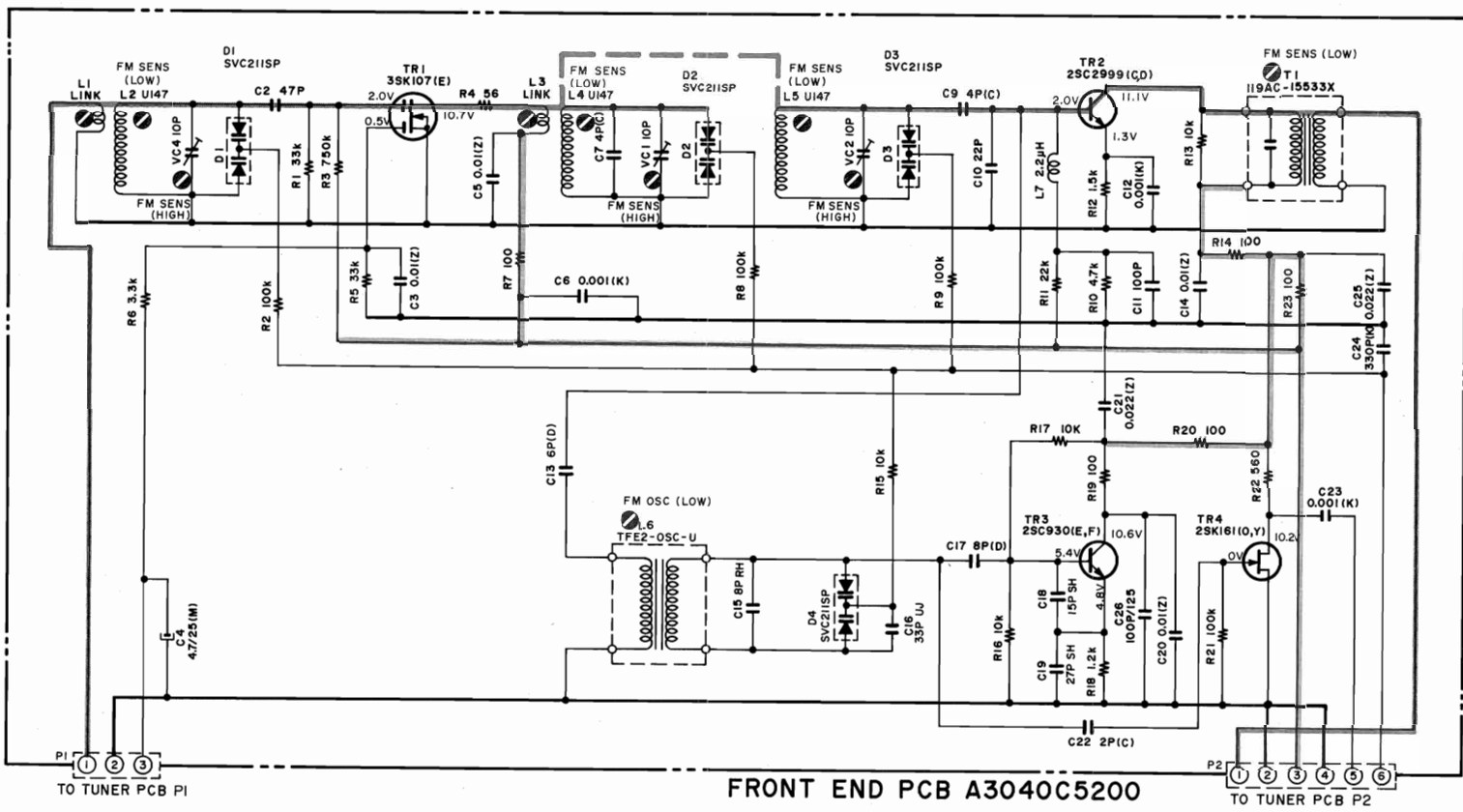

FRONT END PCB A3040C5200

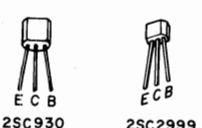

25C930 25C2999

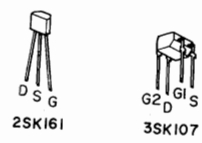

2SK161 3SK107

— +B (POWER SUPPLY) LINE  
 — FM SIGNAL LINE

NOTE  
 UNLESS OTHERWISE SPECIFIED  
 ALL RESISTORS IN OHMS 1/4W(J)  
 ALL CAPACITORS IN μF 50WV(J)

AA-A25/L FRONT END SCHEMATIC DIAGRAM 840224B (A3)

NO. 7-7