

AKAI SERVICE MANUAL

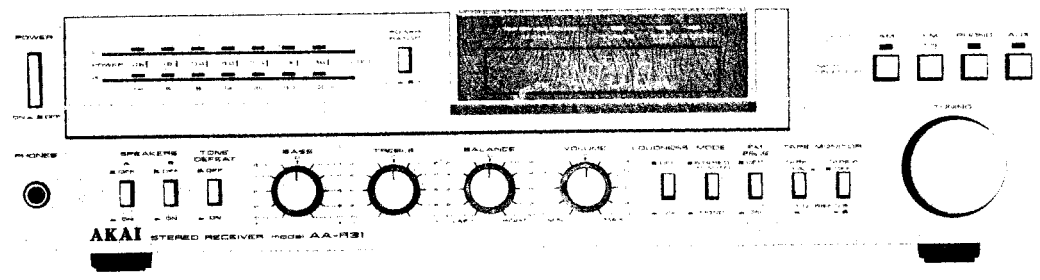
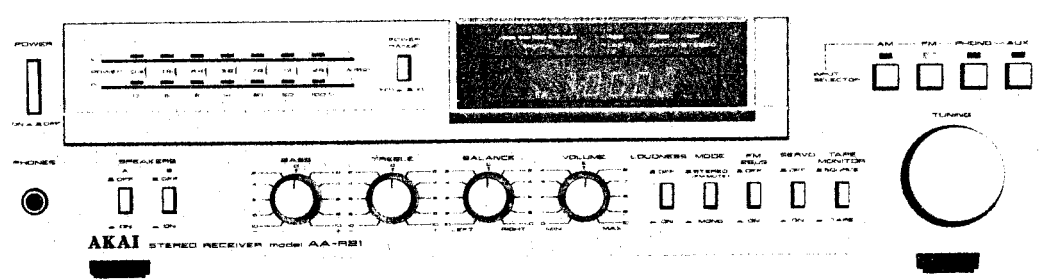

AA-R21
AA-R31

STEREO RECEIVER

MODEL **AA-R21**

MODEL **AA-R31**

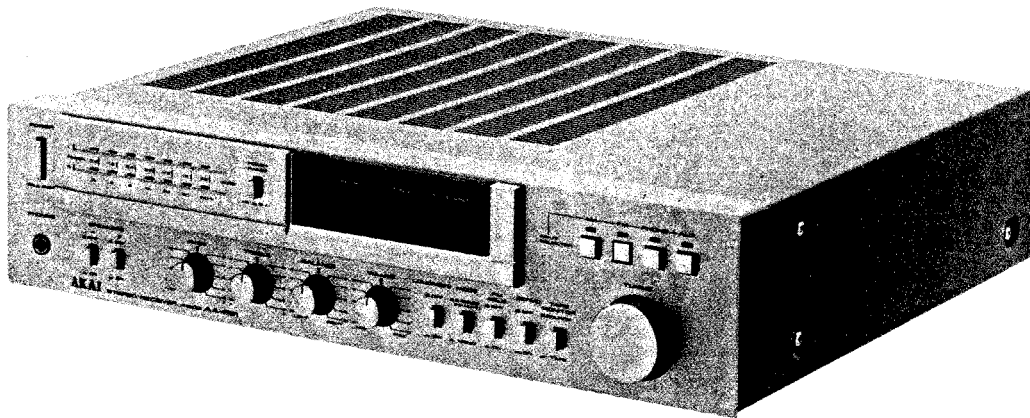

AA-R21

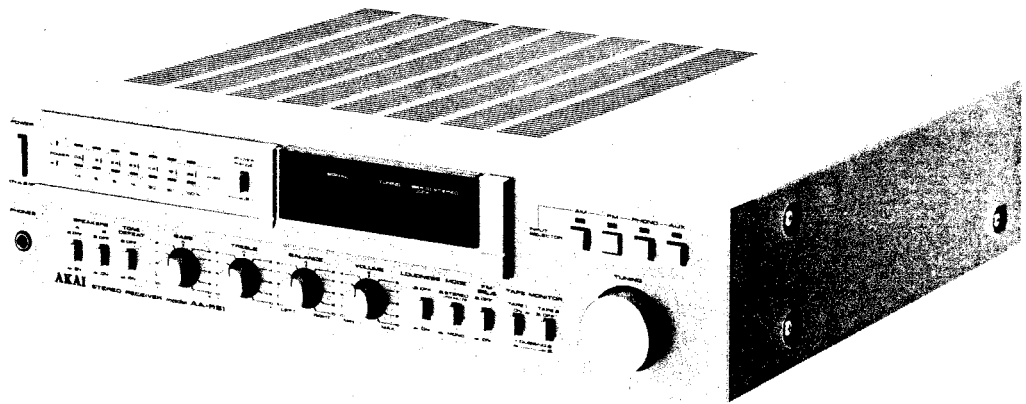

AA-R31

STEREO RECEIVER

AA-R21
MODEL AA-R31

SECTION 1	SERVICE MANUAL	3
SECTION 2	PARTS LIST	31
SECTION 3	SCHEMATIC DIAGRAM	42

SECTION 1

SERVICE MANUAL

TABLE OF CONTENTS

I.	TECHNICAL DATA	4
	1. MODEL AA-R21	4
	2. MODEL AA-R31	5
II.	DISMANTLING OF UNIT	6
III.	CONTROLS	7
	1. MODEL AA-R21	7
	2. MODEL AA-R31	8
IV.	PRINCIPAL PARTS LOCATION	9
V.	VOLTAGE CONVERSION	11
VI.	AMPLIFIER ADJUSTMENTS	12
VII.	TUNER ADJUSTMENTS	14
	1. FM SECTION ADJUSTMENTS	16
	2. AM SECTION ADJUSTMENTS	19
VIII.	CLASSIFICATION OF VARIOUS P.C BOARDS	19
	1. P.C BOARD TITLES AND IDENTIFICATION NUMBERS	19
	2. COMPOSITION OF VARIOUS P.C BOARDS	20

For basic adjustments, measuring methods, and operating principles, refer to GENERAL TECHNICAL MANUAL.

I. TECHNICAL DATA

1. MODEL AA-R21

FM TUNER SECTION

FREQUENCY RANGE		88 MHz to 108 MHz
SENSITIVITY (IHF)		1.9 μ V
CAPTURE RATIO		More than 1.5 dB
SELECTIVITY (IHF)		More than 60 dB
IMAGE REJECTION		More than 50 dB
IF REJECTION		More than 90 dB
SPURIOUS REJECTION		More than 70 dB
AM SUPPRESSION		50 dB
SIGNAL TO NOISE RATIO		65 dB
HARMONIC DISTORTION	MONO	Less than 0.2% (100% modulation)
	STEREO	Less than 0.3% (100% modulation)
MUTING		Switchable to ON-OFF
STEREO SEPARATION		More than 40 dB (1 kHz)
PILOT SIGNAL SUPPRESSION		More than 50 dB
SUB CARRIER SUPPRESSION		More than 50 dB
ANTENNA INPUT IMPEDANCE		300 ohms balanced, 75 ohms unbalanced

AM TUNER SECTION

FREQUENCY RANGE		525 kHz to 1,605 kHz
SENSITIVITY (IHF)		300 μ V/m (Bar Antenna), 20 μ V (External Antenna)
SELECTIVITY (IHF)		More than 30 dB
IMAGE REJECTION		More than 45 dB
IF REJECTION		More than 35 dB
SIGNAL TO NOISE RATIO		More than 40 dB
ANTENNA		Built-in ferrite bar antenna

POWER AMPLIFIER SECTION

RATED POWER OUTPUT (2-channel driven)		26 watts per channel, minimum RMS, at 8 ohms from 20 to 20,000 Hz with no more than 0.05% total harmonic distortion.
POWER BANDWIDTH (IHF)		10 Hz to 30 kHz/8 ohms (Total harmonic distortion: 0.05%)
SIGNAL TO NOISE RATIO (IHF)	PHONO	Better than 78 dB
	AUX	Better than 93 dB
RESIDUAL NOISE		Less than 0.8 mV at 8 ohms
CHANNEL SEPARATION (IHF)	PHONO	Better than 50 dB at 1,000 Hz
	AUX	Better than 50 dB at 1,000 Hz
DAMPING FACTOR		More than 40 (1 kHz, 8 ohms)
OUTPUT	SPEAKERS	A, B (4 to 16 ohms) / A+B (8 to 16 ohms)
	HEADPHONE	4 to 16 ohms
INPUT SENSITIVITY/IMPEDANCE	PHONO	2.5 mV/47 kohms
	AUX	150 mV/47 kohms
	TUNER	150 mV/47 kohms
	TAPE	PIN: 150 mV/47 kohms, DIN: 150 mV/47 kohms
OUTPUT LEVEL/FREQUENCY RESPONSE	TAPE REC	PIN: 150 mV/5 kohms, DIN: 30 mV/80 kohms
	PHONO	30 Hz to 15 kHz +1 dB, -1 dB (RIAA)
	AUX	10 Hz to 50 kHz +1 dB, -2 dB
TONE CONTROL	BASS	\pm 9 dB at 100 Hz
	TREBLE	\pm 9 dB at 10 kHz
LOUDNESS CONTROL		+10 dB at 100 Hz, +6 dB at 10 kHz

MISCELLANEOUS

POWER CONSUMPTION		140 Watts: AAL, CSA and U/T Models 250 Watts: SAA Model
POWER REQUIREMENTS		120V, 60 Hz for U.S.A. and Canada 240V, 50 Hz for Australia 110V/120V/220V/240V, 50/60 Hz for other countries
DIMENSIONS		440(W) \times 105(H) \times 370(D) mm (17.3 \times 4.2 \times 14.8 inches)
WEIGHT		9 kg (19.8 lbs)

* For improvement purposes, specifications and design are subject to change without notice.

2. MODEL AA-R31

FM TUNER SECTION

FREQUENCY RANGE	88 MHz to 108 MHz
SENSITIVITY (IHF)	1.9 μ V
CAPTURE RATIO	More than 1.5 dB
SELECTIVITY (IHF)	More than 60 dB
IMAGE REJECTION	More than 50 dB
IF REJECTION	More than 90 dB
SPURIOUS REJECTION	More than 70 dB
AM SUPPRESSION	50 dB
SIGNAL TO NOISE RATIO	70 dB
HARMONIC DISTORTION	MONO STEREO
	Less than 0.15% (100% modulation)
	Less than 0.25% (100% modulation)
MUTING	Switchable to ON-OFF
STEREO SEPARATION	More than 40 dB (1 kHz)
PILOT SIGNAL SUPPRESSION	More than 50 dB
SUB CARRIER SUPPRESSION	More than 50 dB
ANTENNA INPUT IMPEDANCE	300 ohms balanced, 75 ohms unbalanced

AM TUNER SECTION

FREQUENCY RANGE	525 kHz to 1,605 kHz
SENSITIVITY (IHF)	300 μ V/m (Bar Antenna), 20 μ V (External Antenna)
SELECTIVITY (IHF)	More than 30 dB
IMAGE REJECTION	More than 45 dB
IF REJECTION	More than 35 dB
SIGNAL TO NOISE RATIO	More than 40 dB
ANTENNA	Built-in ferrite bar antenna

POWER AMPLIFIER SECTION

RATED POWER OUTPUT (2-channel driven)	38 watts per channel, minimum RMS, at 8 ohms from 20 to 20,000 Hz with no more than 0.05% total harmonic distortion.
POWER BANDWIDTH (IHF)	10 Hz to 30 kHz/8 ohms (Total harmonic distortion: 0.05%)
SIGNAL TO NOISE RATIO (IHF)	PHONO AUX
	Better than 80 dB Better than 95 dB
RESIDUAL NOISE	Less than 0.7 mV at 8 ohms
CHANNEL SEPARATION (IHF)	PHONO AUX
	Better than 50 dB at 1,000 Hz Better than 50 dB at 1,000 Hz
DAMPING FACTOR	More than 40 (1 kHz, 8 ohms)
OUTPUT	SPEAKERS HEADPHONE
	A, B (4 to 16 ohms) / A+B (8 to 16 ohms) 4 to 16 ohms
INPUT SENSITIVITY/IMPEDANCE	PHONO AUX TUNER TAPE
	2.5 mV/47 kohms 150 mV/47 kohms 150 mV/47 kohms PIN: 150 mV/47 kohms, DIN: 150 mV/47 kohms
OUTPUT LEVEL/FREQUENCY RESPONSE	TAPE REC PHONO AUX
	PIN: 150 mV/5 kohms, DIN: 30 mV/80 kohms 30 Hz to 15 kHz +1 dB, -1 dB (RIAA) 10 Hz to 50 kHz +1 dB, -2 dB
TONE CONTROL	BASS TREBLE
	\pm 9 dB at 100 Hz \pm 9 dB at 10 kHz
LOUDNESS CONTROL	+10 dB at 100 Hz, +6 dB at 10 kHz

MISCELLANEOUS

POWER CONSUMPTION	180 Watts: AAL, CSA and U/T Models 290 Watts: SAA Model
POWER REQUIREMENTS	120V, 60 Hz for U.S.A. and Canada 240V, 50 Hz for Australia 110V/120V/220V/240V, 50/60 Hz for other countries
DIMENSIONS	440(W) \times 105(H) \times 370(D) mm (17.3 \times 4.2 \times 14.8 inches)
WEIGHT	9.5 kg (20.9 lbs)

* For improvement purposes, specifications and design are subject to change without notice.

II. DISMANTLING OF UNIT

In case of trouble, etc. necessitating dismantling, please dismantle in the order shown in the photographs. Reassemble in reverse order.

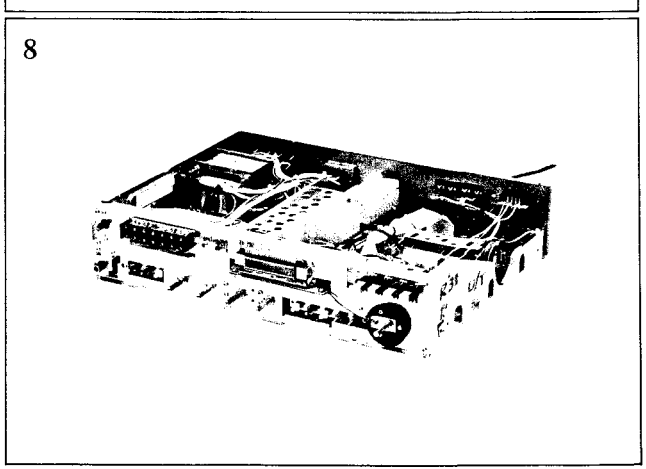
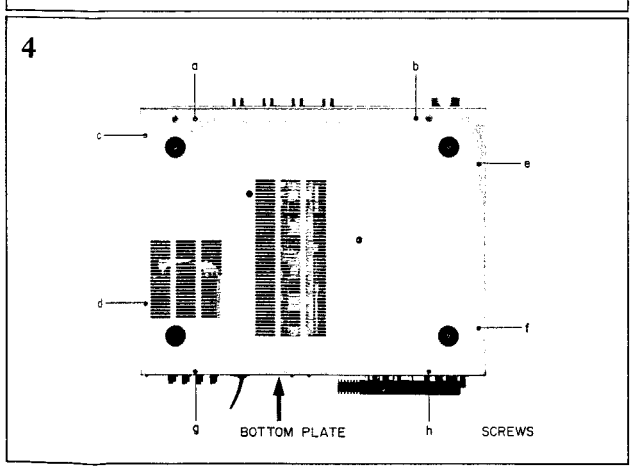
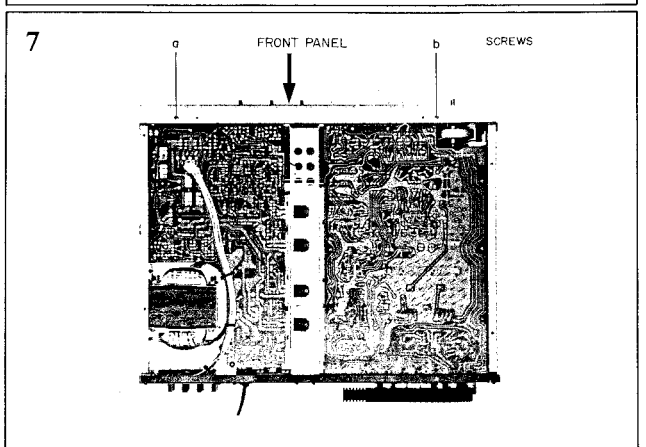
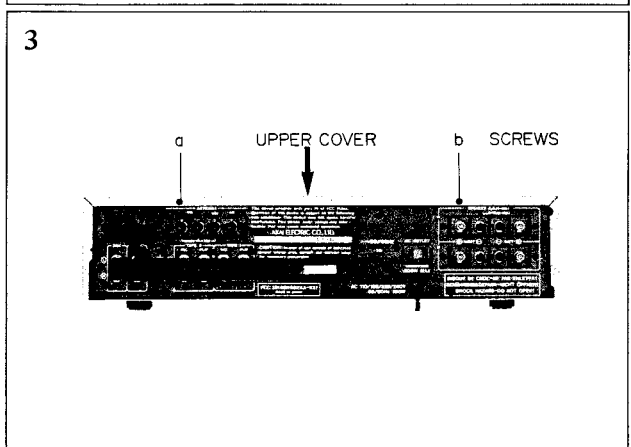
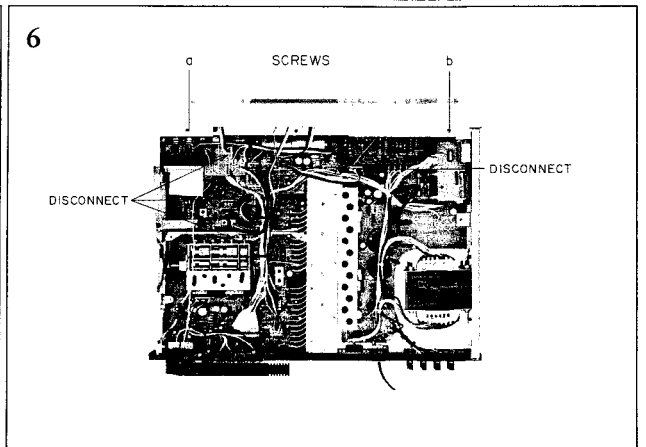
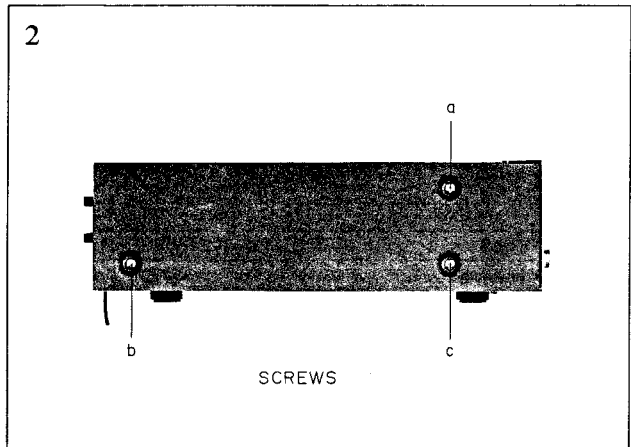
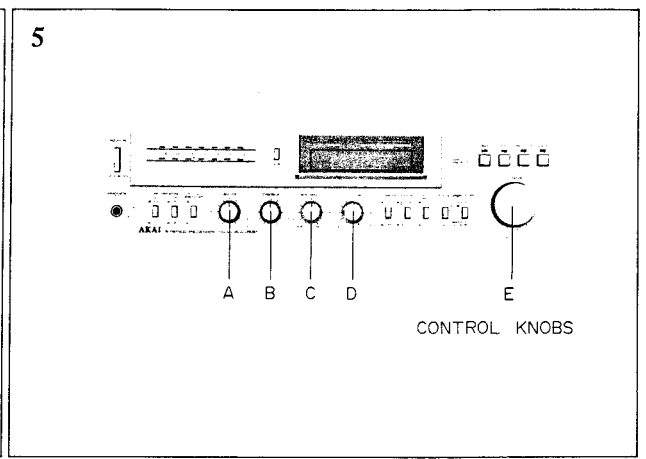
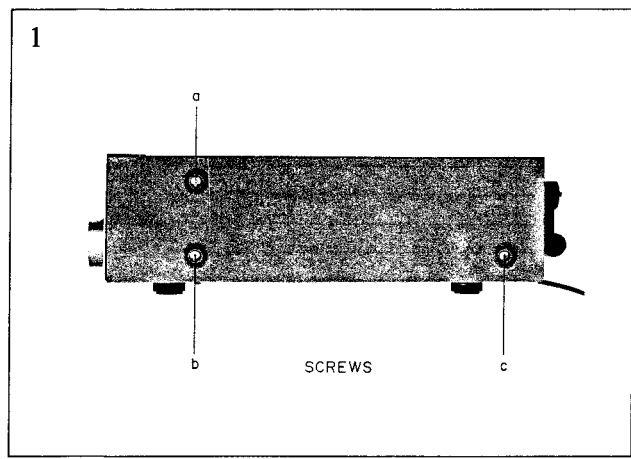

III. CONTROLS

1. MODEL AA-R21

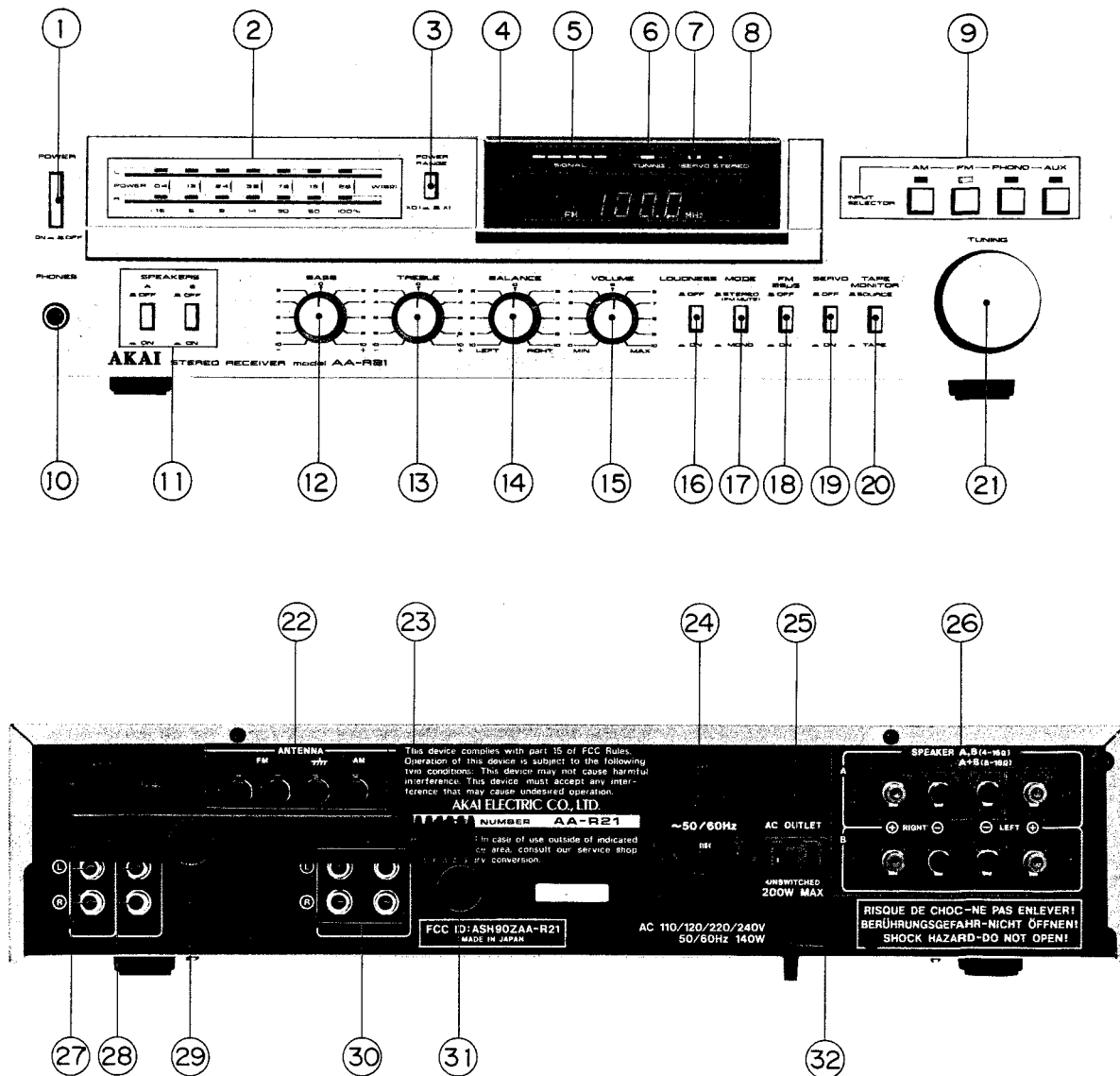

Fig. 1 Controls (AA-R21)

- | | |
|--------------------------------------|--|
| 1. POWER SWITCH | 17. MODE SELECTOR |
| 2. LED OUTPUT BAR METER | 18. FM 25 μ SEC SWITCH |
| 3. POWER RANGE SELECTOR | 19. SERVO SWITCH |
| 4. DIGITAL LED DISPLAY | 20. TAPE MONITOR SWITCH |
| 5. LED SIGNAL STRENGTH INDICATOR | 21. TUNING KNOB |
| 6. FM CENTER TUNING INDICATOR | 22. FM AND AM ANTENNA TERMINALS |
| 7. FM SERVO INDICATOR | 23. AM FERRITE BAR ANTENNA |
| 8. FM STEREO INDICATOR | 24. VOLTAGE SELECTOR (U/T Model Only) |
| 9. INPUT SELECTOR AND INDICATORS | 25. AC OUTLET (AAL, CSA and U/T Models Only) |
| 10. HEADPHONE JACK (PHONES) | 26. A AND B SPEAKER SYSTEM TERMINALS |
| 11. SPEAKER SYSTEM SELECTOR SWITCHES | 27. AUX JACKS |
| 12. BASS CONTROL | 28. PHONO JACKS |
| 13. TREBLE CONTROL | 29. GROUND TERMINAL |
| 14. STEREO BALANCE CONTROL | 30. TAPE SYSTEM REC/PLAY JACKS |
| 15. VOLUME CONTROL | 31. DIN JACK (SAA Model Only) |
| 16. LOUDNESS SWITCH | 32. AC CORD |

2. MODEL AA-R31

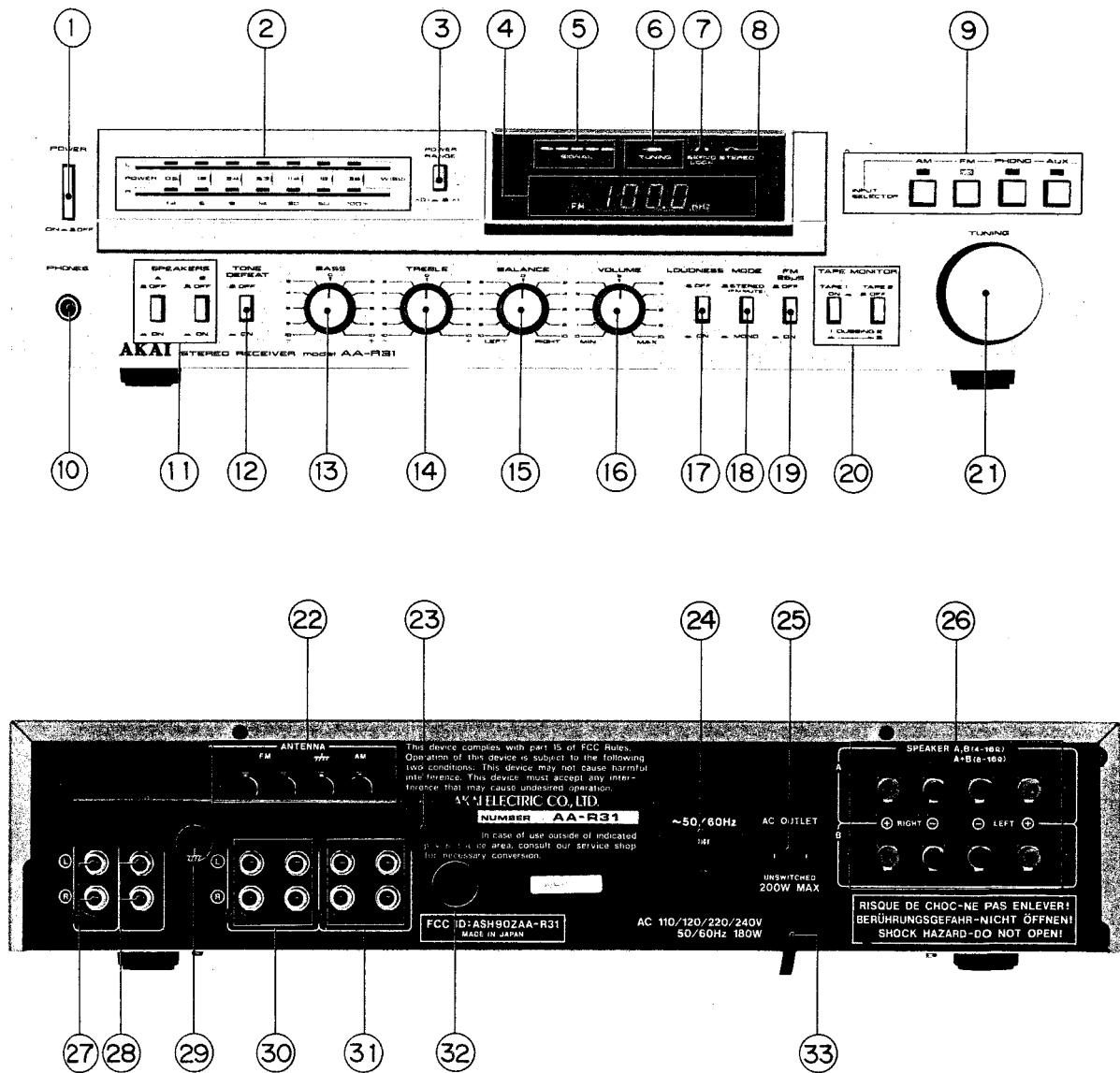

Fig. 2 Controls (AA-R31)

- | | |
|--------------------------------------|--|
| 1. POWER SWITCH | 18. MODE SELECTOR |
| 2. LED OUTPUT BAR METER | 19. FM 25 μ SEC SWITCH |
| 3. POWER RANGE SELECTOR | 20. TAPE MONITOR SWITCHES |
| 4. DIGITAL LED DISPLAY | 21. TUNING KNOB |
| 5. LED SIGNAL STRENGTH INDICATOR | 22. FM AND AM ANTENNA TERMINALS |
| 6. FM CENTER TUNING INDICATOR | 23. AM FERRITE BAR ANTENNA |
| 7. FM SERVO LOCK INDICATOR | 24. VOLTAGE SELECTOR (U/T Model Only) |
| 8. FM STEREO INDICATOR | 25. AC OUTLET (AAL, CSA and U/T Models Only) |
| 9. INPUT SELECTOR AND INDICATORS | 26. A AND B SPEAKER SYSTEM TERMINALS |
| 10. HEADPHONE JACK (PHONES) | 27. AUX JACKS |
| 11. SPEAKER SYSTEM SELECTOR SWITCHES | 28. PHONO JACKS |
| 12. TONE DEFEAT SWITCH | 29. GROUND TERMINAL |
| 13. BASS CONTROL | 30. TAPE 2 SYSTEM REC/PLAY JACKS |
| 14. TREBLE CONTROL | 31. TAPE 1 SYSTEM REC/PLAY JACKS |
| 15. STEREO BALANCE CONTROL | 32. DIN JACK (SAA Model Only) |
| 16. VOLUME CONTROL | 33. AC CORD |
| 17. LOUDNESS SWITCH | |

IV. PRINCIPAL PARTS LOCATION

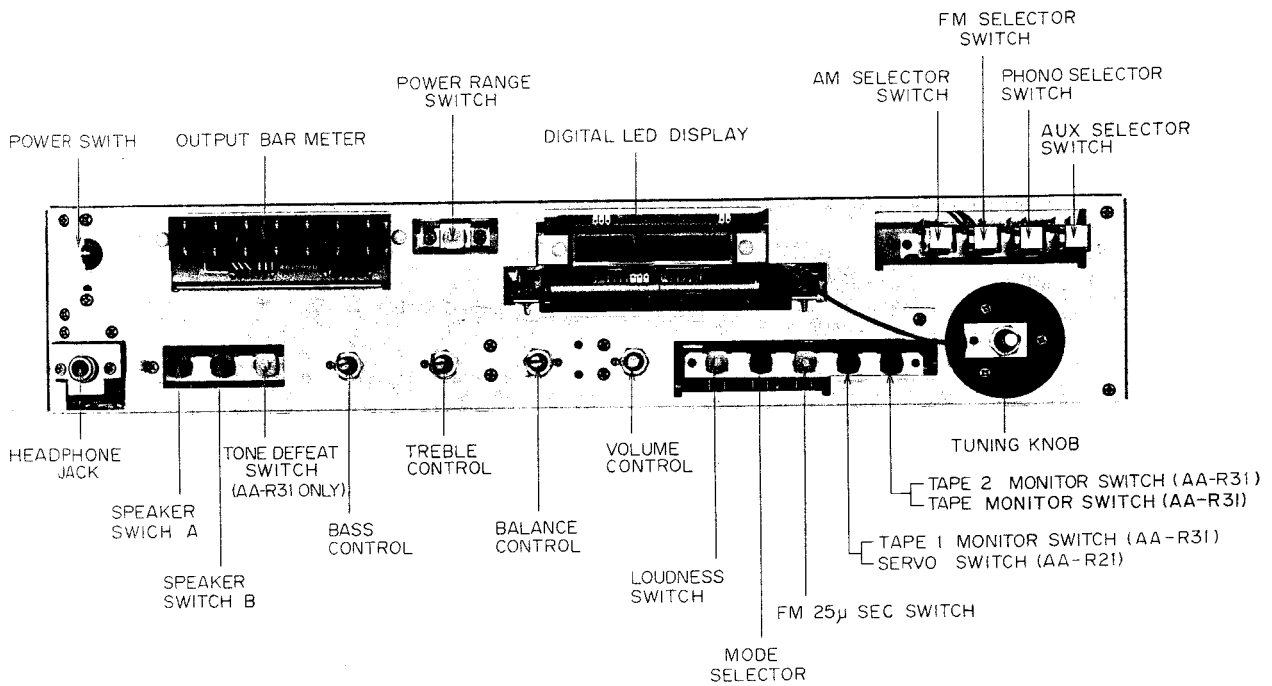

Fig. 3 Front View

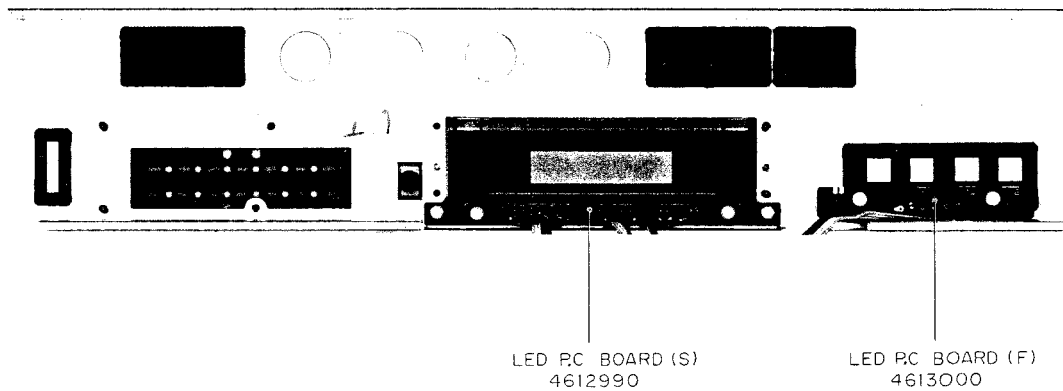

Fig. 4 Back View of Front Panel

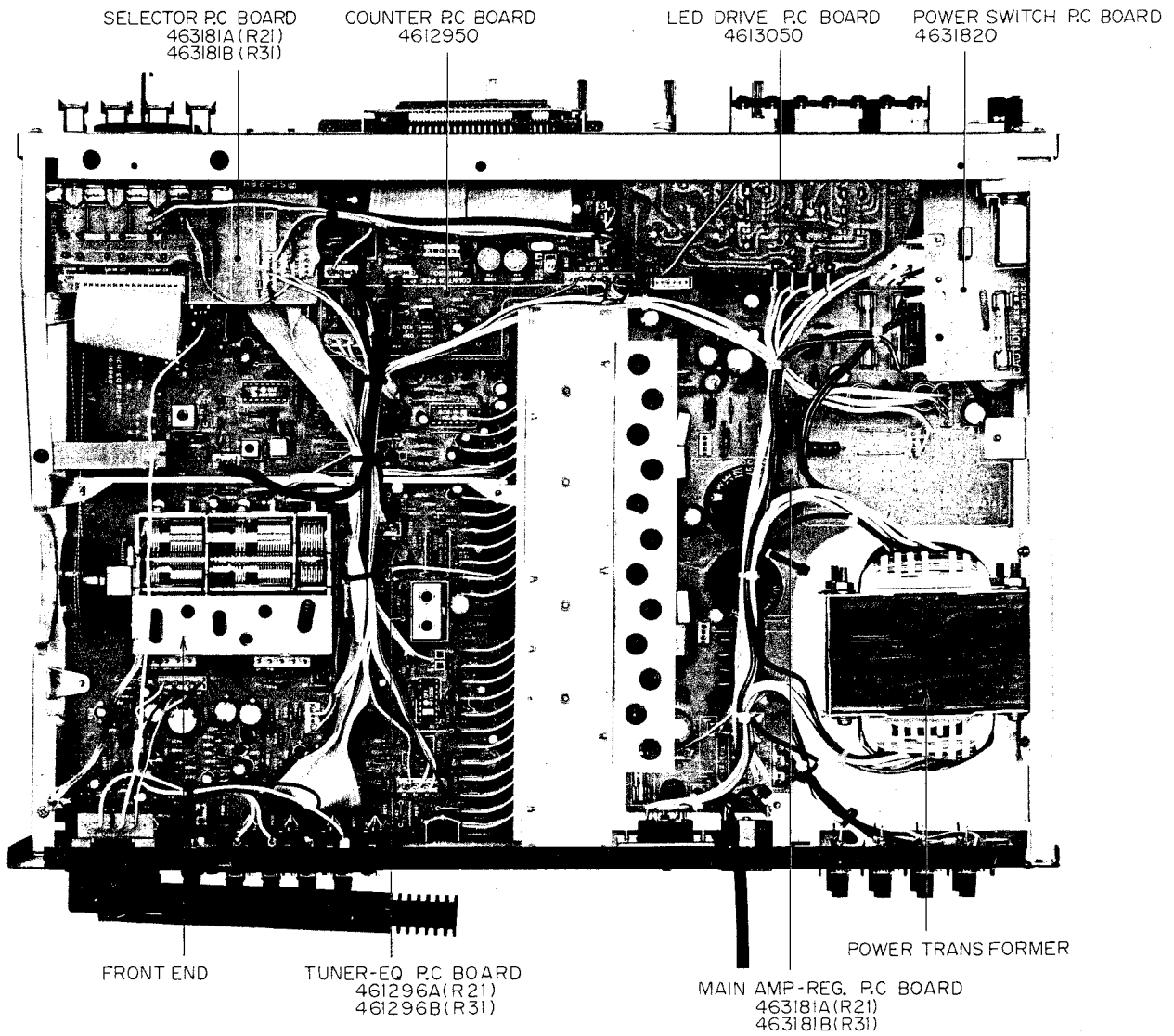

Fig. 5 Top View

V. VOLTAGE CONVERSION

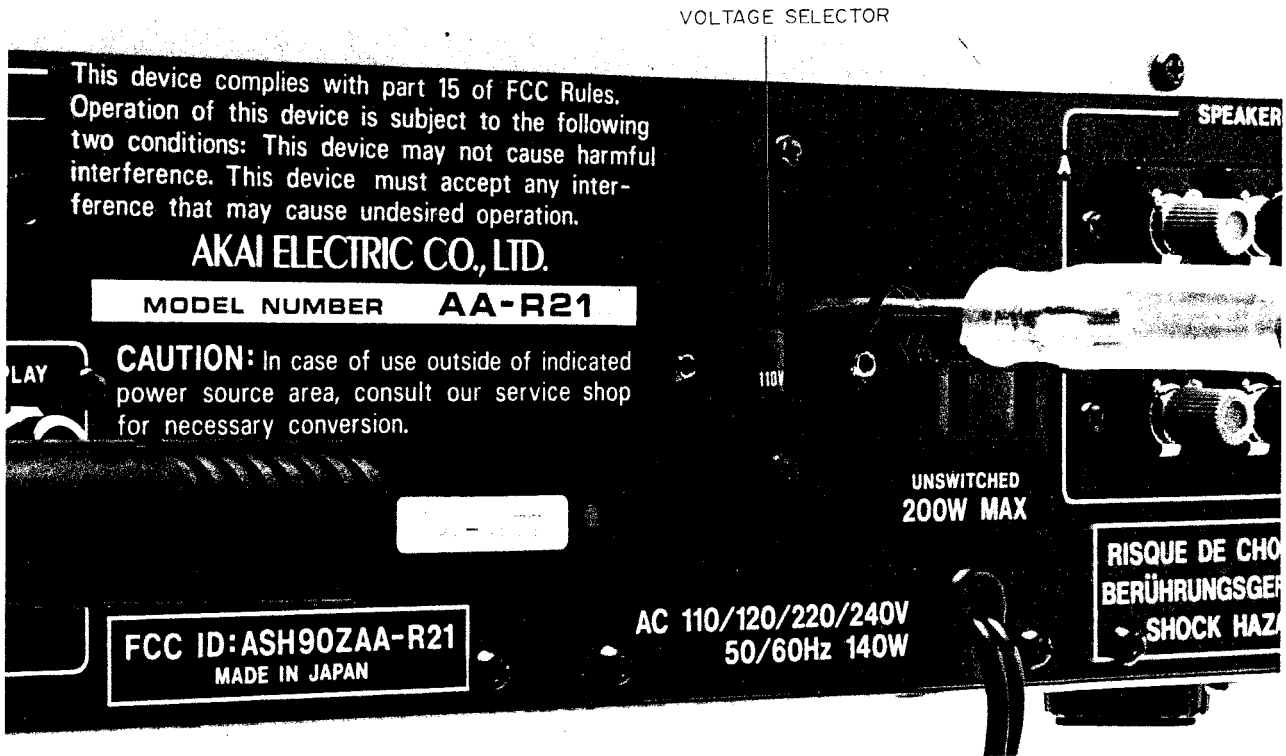

Fig. 6 Voltage Conversion (U/T Model Only)

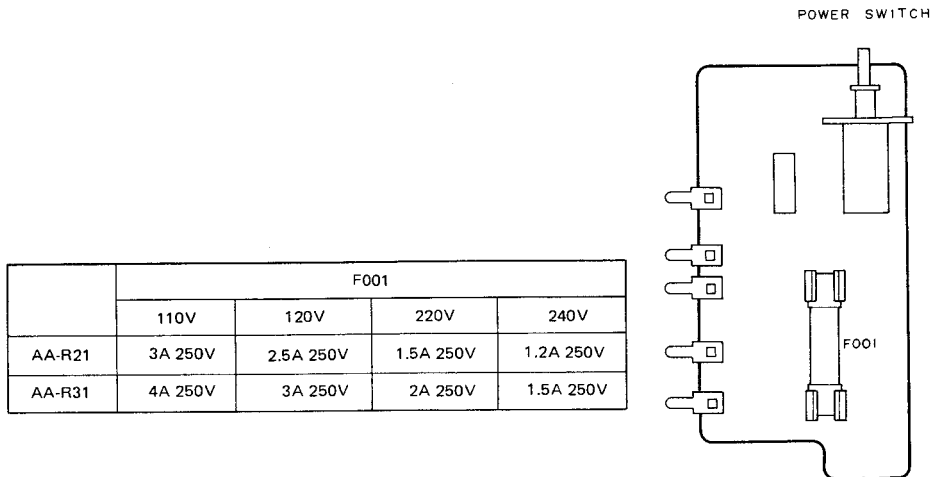

Fig. 7 Power Switch P.C Board

Models for Canada, U.S.A. and Australia are not equipped with this facility. Each machine is preset at the factory according to destination but some machines can be set to 110V, 120V, 220V or 240V as required. If voltage change is necessary, this can be accomplished as follows.

1. Disconnect power cord.
2. Loosen holding screws and remove the plate of the Voltage Selector above the voltage indication.
3. Turn with a screwdriver until the correct voltage for your area is shown. (Refer to Fig. 6)
4. Loosen holding screws and remove the upper cover.
5. Change the fuse (F001) located on the Power Switch P.C Board. (Refer to Fig. 5 and Fig. 7)

VI. AMPLIFIER ADJUSTMENT

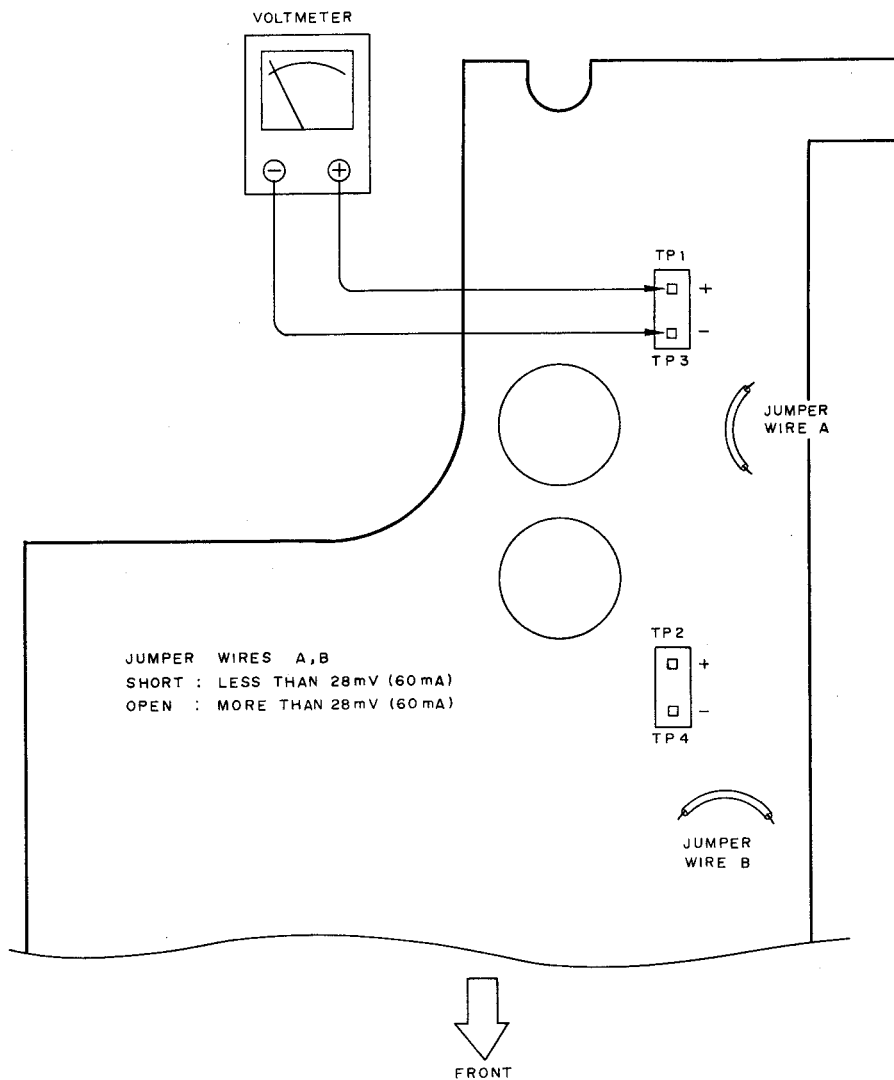

Fig. 8 Main Amp-Reg. P.C Board 463181A (AA-R21), 463181B (AA-R31)

1. IDLING CURRENT ADJUSTMENT

(Refer to Fig. 8)

Connect a high-sensitivity voltmeter between TP1 and TP3 (left channel) and between TP2 and TP4 (right channel). If the measured voltage is more than 28 mV (60 mA) with no input signal, cut the jumper wires A (left channel) and B (right channel).

If it is less than 28 mV (60 mA), do not cut the jumper wire, and confirm that the voltage lies between 1.5 mV (6 mA) and 28 mV (60 mA).

NOTE: It takes about 5 minutes for the idling current to stabilize.

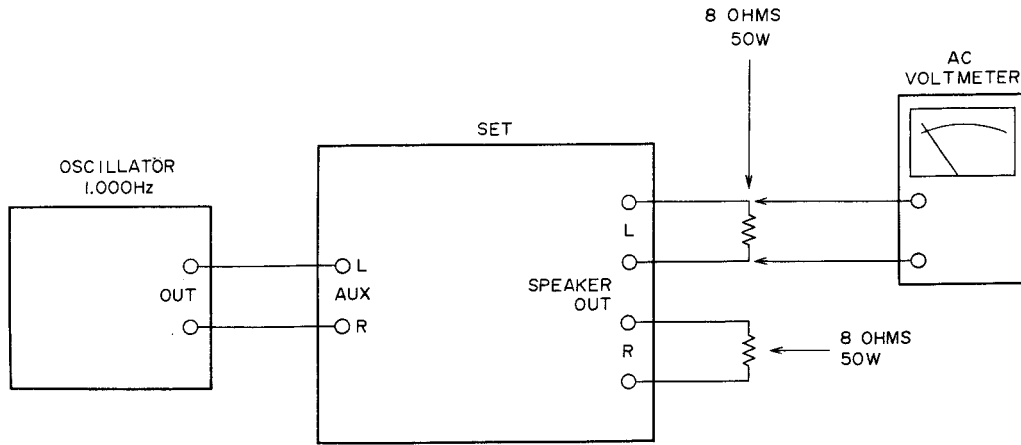

Fig. 9 Instrument Connections

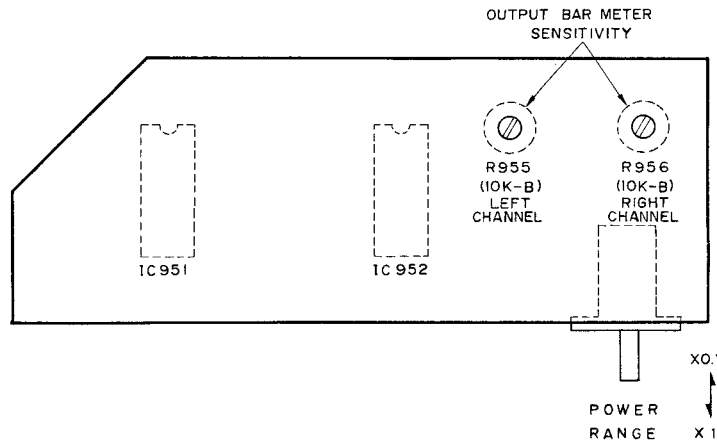

Fig. 10 LED Drive P.C Board 4613050 (Pattern Side View)

2. OUTPUT BAR METER SENSITIVITY ADJUSTMENT (Refer to Figs. 9, 10)

Set the Power Range switch to "X1", and connect the RL (8 ohms) resistors to Speaker Out. Then apply a 1 kHz signal to the AUX input terminals, adjusting the input level so as to obtain the rated output voltage level at Speaker Out.

(AA-R21: 14.42V, AA-R31: 17.43V)

Adjust R955 (left) and R956 (right) on the LED Drive P.C Board so that the 7th LED in the output bar meter lights up. Next decrease the input level by 10 dB and check that the 3rd LED remains on. Then switch the Power Range switch to "X0.1", and check that the 6th LED light up.

VII. TUNER ADJUSTMENT

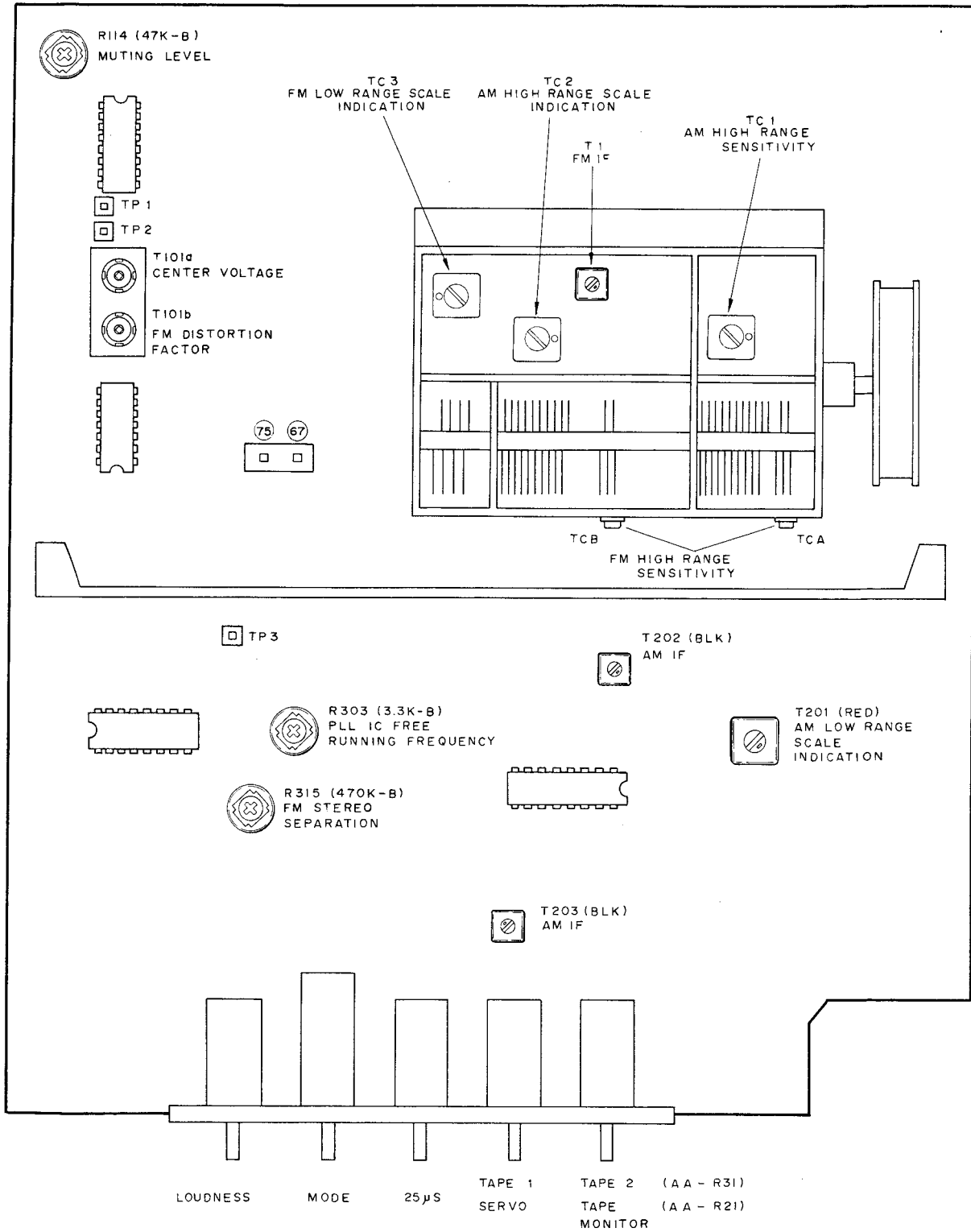

Fig. 11 Tuner-EQ P.C Board 461296A (AA-R21), 461296B (AA-R31)

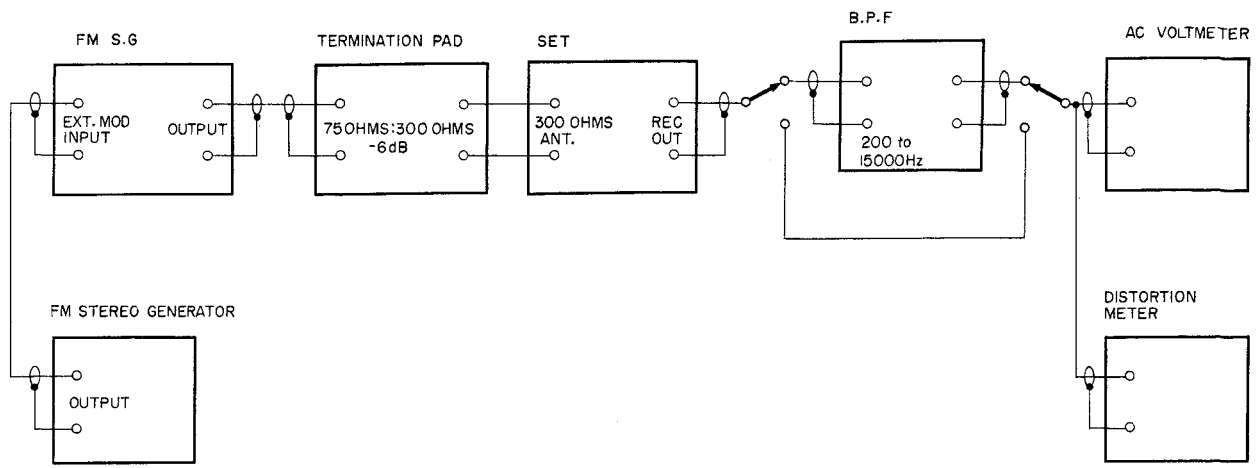

Fig. 12 Instrument Connections

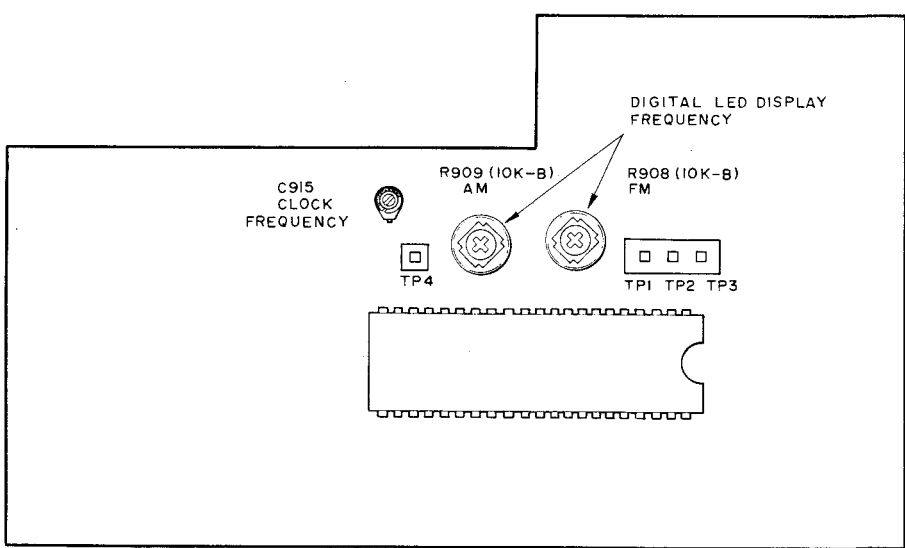

Fig. 13 Counter P.C Board 4612950

1. FM SECTION ADJUSTMENTS (Refer to Figs. 11, 12, 13)

Unless otherwise specified, use the adjustment points provided on the Tuner-EQ P.C Board (Fig. 11).

Step	Adjustment Item	Adjustment Point	Result	Remarks
1	Front-end IF Coil	T1 (Front-end)	Maximum Noise Level	Switch SELECTOR to FM, and MODE to MONO. Turns only noise without interference from broadcasting.
2	Center Voltage	T101a	Centered Tuning Meter Indication	Connect a Center Tuning Meter between TP1 and TP2. (See Note 1) Turns only noise without interference from broadcasting.
3	Distortion Factor	T101b	Less than 0.15% Distortion Factor	108 MHz, 60 dB, 400 Hz (mono 100%) input. Switch MODE to MONO, and SERVO to OFF (AA-R31: See Note 2). Less than 0.15% in both channels.
4				Readjust in Steps 2 and 3.
5	Confirmation of AFC (AA-R21 Only)			Switch SERVO to OFF. Tune away from station by ± 20 kHz to 30 kHz, and switch SERVO to ON. The center tuning meter will indicate center position, and the SERVO LED light up.
6	Muting Level	R114 (47KB)	30 dB \pm 6 dB	Switch MODE to STEREO. 108 MHz, 30 dB, 400 Hz (mono 100%) input. Adjust R114 until the output signal is reduced to zero. Vary the SSG output by ± 6 dB and check muting operation.
7	Confirmation of Signal LED Sensitivity			108 MHz, 50 dB \pm 10 dB input. Check that all 5 signal meter LEDs light up.
8	Confirmation of Output Level and Channel Balance		Output Level: 150 mV \pm 2 dB Channel Balance: Within 1.5 dB	108 MHz, 60 dB, 400 Hz (mono 100%) input.
9	Digital LED Display Clock Frequency	C915 (Counter P.C Board Fig. 13)	4,000,000 Hz \pm 9 Hz	Connect a Frequency Counter between TP4 and GND on the Counter P.C Board. Adjust C915 to obtain a reading of 4,000,000 Hz \pm 9 Hz in the frequency counter.
10	Digital LED Display Frequency	R908 (10KB) (Counter P.C Board Fig. 13)		Apply a 92 MHz, 60 dB input signal. Short TP1 to TP3 on the Counter P.C Board. Adjust VR908 (10KB) until 3rd numeral display becomes stable position. (See Note 3)
11	Low Range Scale Indication	TC3 (Front-end)	87.4 MHz	Turn tuning knob fully counterclockwise. Display 87.4 MHz by adjusting TC3.
12	Confirmation of High Range Scale Indication			Turn tuning knob fully clockwise. Confirm that 109 MHz \pm 0.5 MHz is displayed.

Step	Adjustment Item	Adjustment Point	Result	Remarks
13	High Range Sensitivity	TC-A, TC-B (Front-end)	Less than 3% Distortion Factor	Switch MODE to MONO. 108 MHz, Less than 8 dB, 400 Hz (mono) input.
14	Confirmation of Low Range Sensitivity		Less than 3% Distortion Factor	Switch MODE to MONO. 88 MHz, Less than 8 dB, 400 Hz (mono) input. See Notes 4 and 5.
15	PLL IC Free Running Frequency	R303 (3.3KB)	76 kHz \pm 0.1 kHz	Switch MODE to STEREO. 98 MHz, 60 dB input. Connect a Frequency Counter between TP3 and GND.
16	Stereo Separation	R315 (470KB)	More than 40 dB	98 MHz, 60 dB 1 kHz (stereo) input. Adjust stereo separation to optimum position.
17	Confirmation of Stereo Indicator Lighting			98 MHz, 60 dB (stereo) input. Stereo Indicator should light up. Check that the stereo indicator turns off when the MODE selector is switched to MONO.
18	Confirmation of Stereo Distortion Factor		Less than 0.25% Distortion Factor	100 MHz, 60 dB, 1 kHz (stereo) input. If distortion exceeds 0.25%, first check according to Steps 2, 3, 14 and 15, and then readjust according to Step 1.

- NOTES:**
1. For the Center Meter should be used the tuning meter and the like available as a part of the other models.
 2. Adjust AA-R31 while touching the tuning knob or terminal (75) on the Tuner-EQ P.C Board. Then after completing the adjustment, release the hand and check that the SERVO LOCK LED lights up and that the center tuning meter indicates center position.

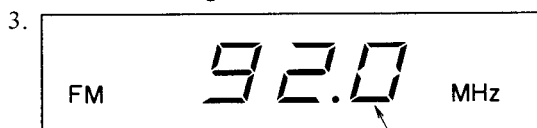

The optimum point of adjustment is when the indicated figure stops flashing.

4. When the specified sensitivity of 8 dB cannot be obtained at the two frequency points, 88 MHz and 108 MHz, repeat the adjustment as described in Step 13.
5. When the sensitivity distortion factor still does not comply with the data specifications, adjust by tuning the Front-end IF coil core, but by not more than 1/2 turn.

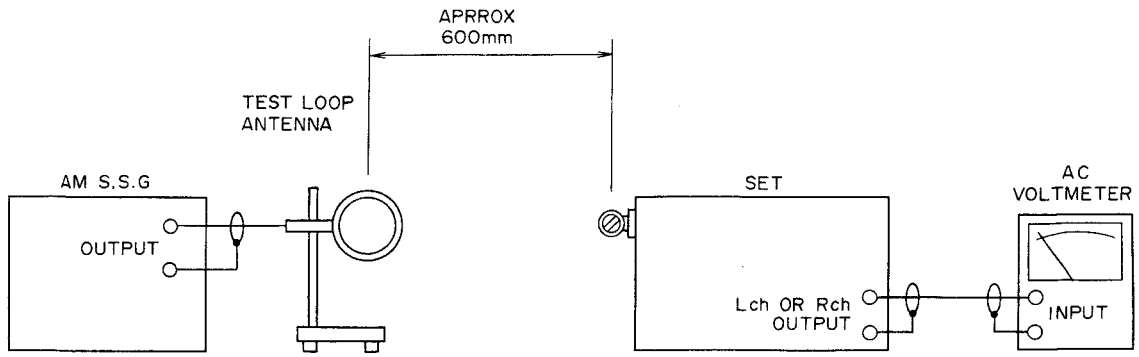

Fig. 14 Instrument Connections

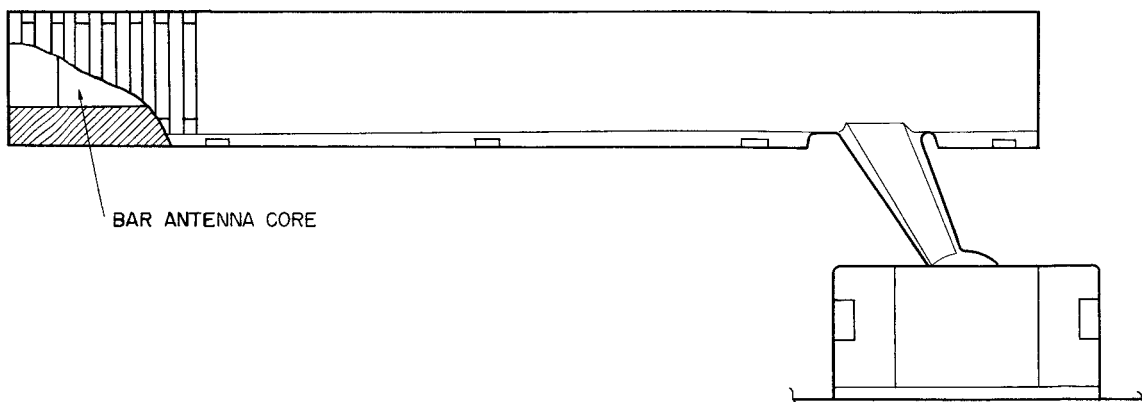

Fig. 15 Bar Antenna

VIII. CLASSIFICATION OF VARIOUS P.C BOARDS

2. AM SECTION ADJUSTMENTS (Refer to Figs. 11, 13, 14, 15)

Unless otherwise specified, use the adjustment points provided on the Tuner-EQ P.C Board (Fig. 11)

Step	Adjustment Item	Adjustment Point	Result	Remarks
1	AM IF Coil	T202 (BLK) T203 (BLK)	Maximum Output	1,000 kHz, 50 dB, 400 Hz (30%) input.
2	Low Range Scale Indication	T201 (RED)		Turn tuning knob fully counterclockwise. Display 520 kHz by adjusting T201.
3	High Range Scale Indication	TC2 (Front-end)		Turn tuning knob fully clockwise. Display 1,650 kHz by adjusting TC2.
4				Readjust in Steps 2 and 3.
5	Low Range Sensitivity	Bar Antenna Core	Maximum Output	600 kHz, 50 dB, 400 Hz (30%) input.
6	High Range Sensitivity	TC1 (Front-end)	Maximum Output	1,400 kHz, 50 dB, 400 Hz (30%) input.
7	Digital LED Display Frequency	R909 (10KB) (Counter P.C Board Fig. 13)		Apply a 1,000 kHz, 50 dB input signal. Short TP1 to TP3, and TP2 to TP3 on the Counter P.C Board. Adjust VR909 (10KB) until 4th numeral display becomes stable position. (See Note 1)
8	Confirmation of Output Level		150 mV \pm 2 dB	1,000 kHz, 74 dB, 1 kHz (100%) input.
9	Confirmation of Signal LED Sensitivity			1,000 kHz, 74 dB input. Check that at least 4 signal LEDs light up.

NOTES: 1.

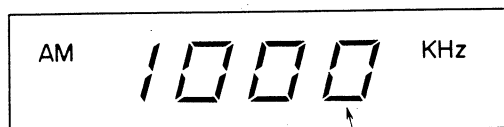

The optimum point of adjustment is when the indicated figure stops flashing.

2. For best result, repeat Steps 1 through 6 two or three times.

1. P.C BOARD TITLES AND IDENTIFICATION NUMBERS

P.C Board TITLE	P.C Board Number
Tuner-EQ P.C Board	461296A (AA-R21) 461296B (AA-R31)
Main Amp-Reg. P.C Board	463181A (AA-R21) 463181B (AA-R31)
Selector P.C Board	463181A (AA-R21) 463181B (AA-R31)
Power Switch P.C Board	4631820
Counter P.C Board	4612950
LED P.C Board (S)	4612990
LED P.C Board (F)	4613000
Balance VR P.C Board	4613010
Sub P.C Board (F)	4613020
Sub P.C Board (L)	4613030
LED Drive P.C Board	4612050

2. COMPOSITION OF VARIOUS P.C BOARDS

1) TUNER-EQ P.C BOARD 461296A (AA-R21) and BALANCE VR P.C BOARD 4613010

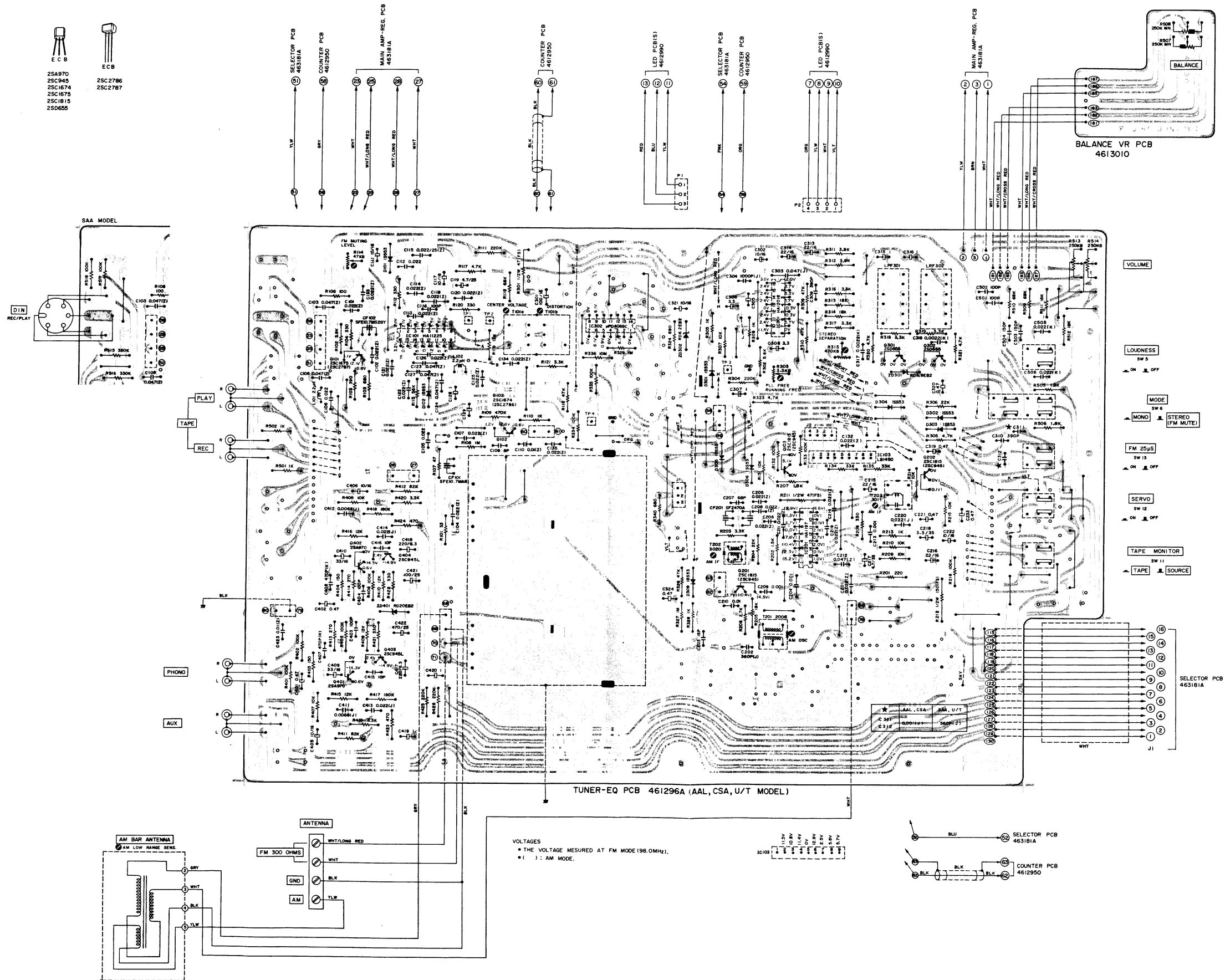

2) TUNER-EQ P.C BOARD 461296B (AA-R31) and BALANCE VR P.C BOARD 4613010

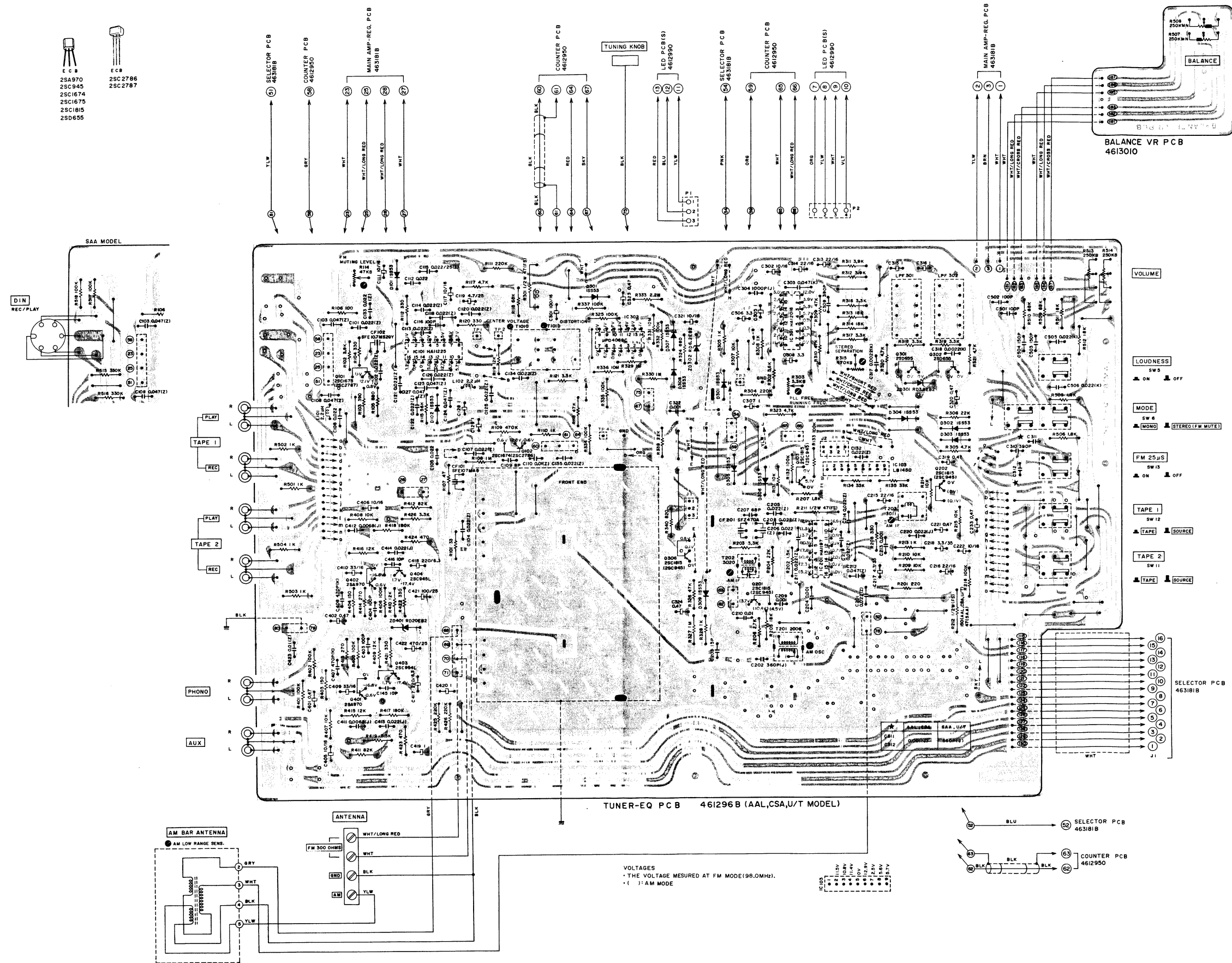

3) MAIN AMP-REG. P.C BOARD 463181A (AA-R21), 463181B (AA-R31)

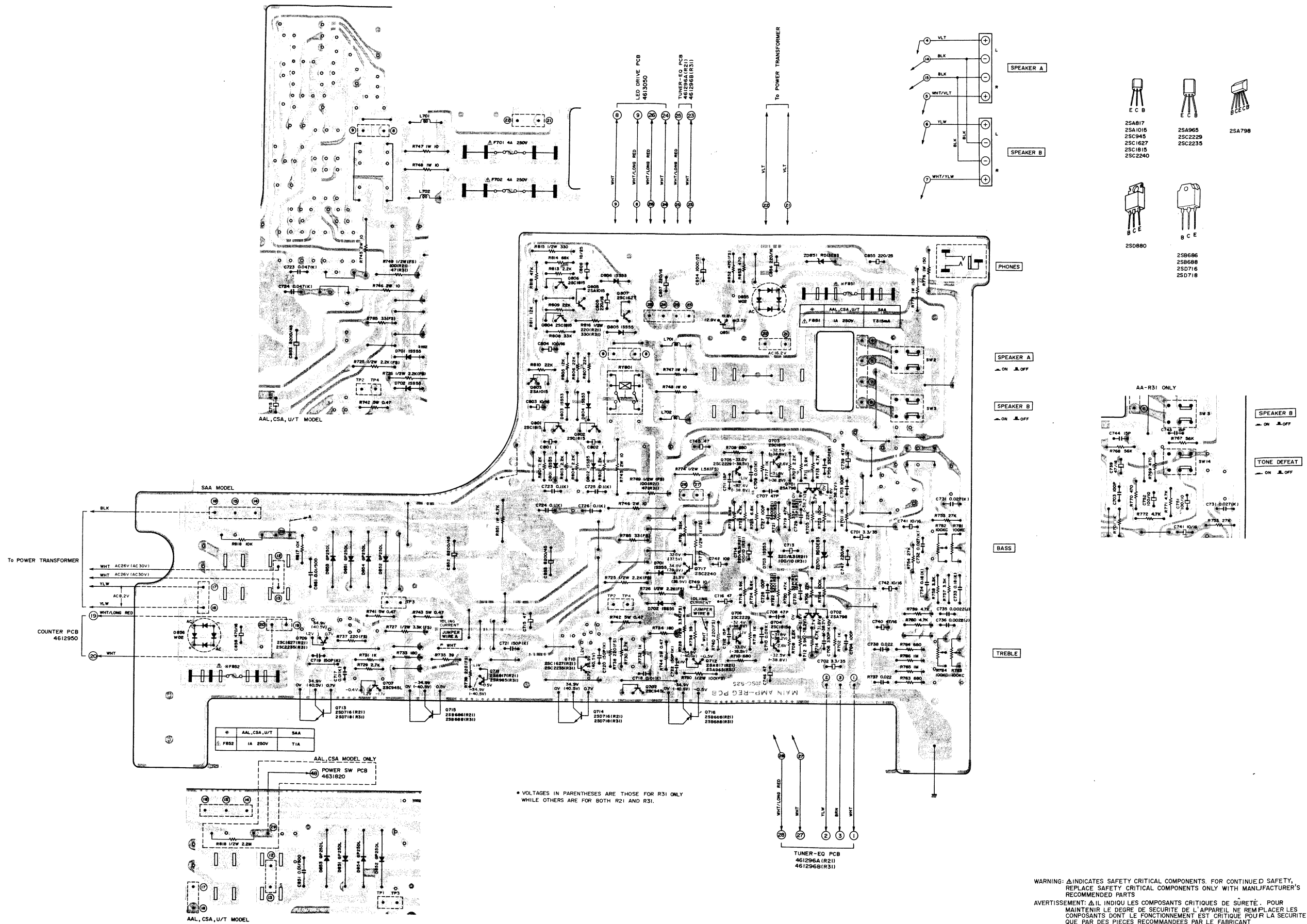

4) SELECTOR P.C BOARD 463181A (AA-R21), 463181B (AA-R31), LED P.C BOARD (F) 4613000 and SUB P.C BOARD (F) 4613020

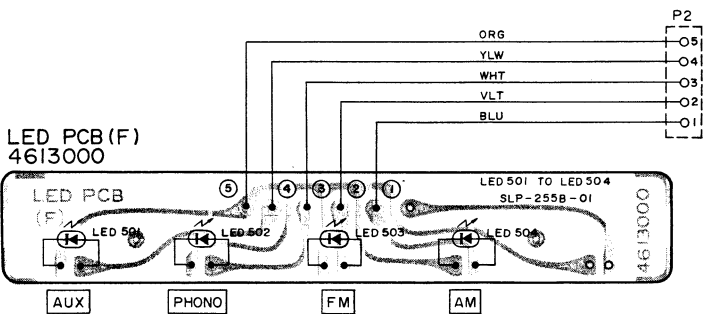
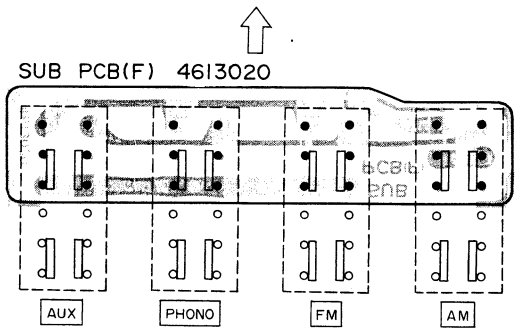
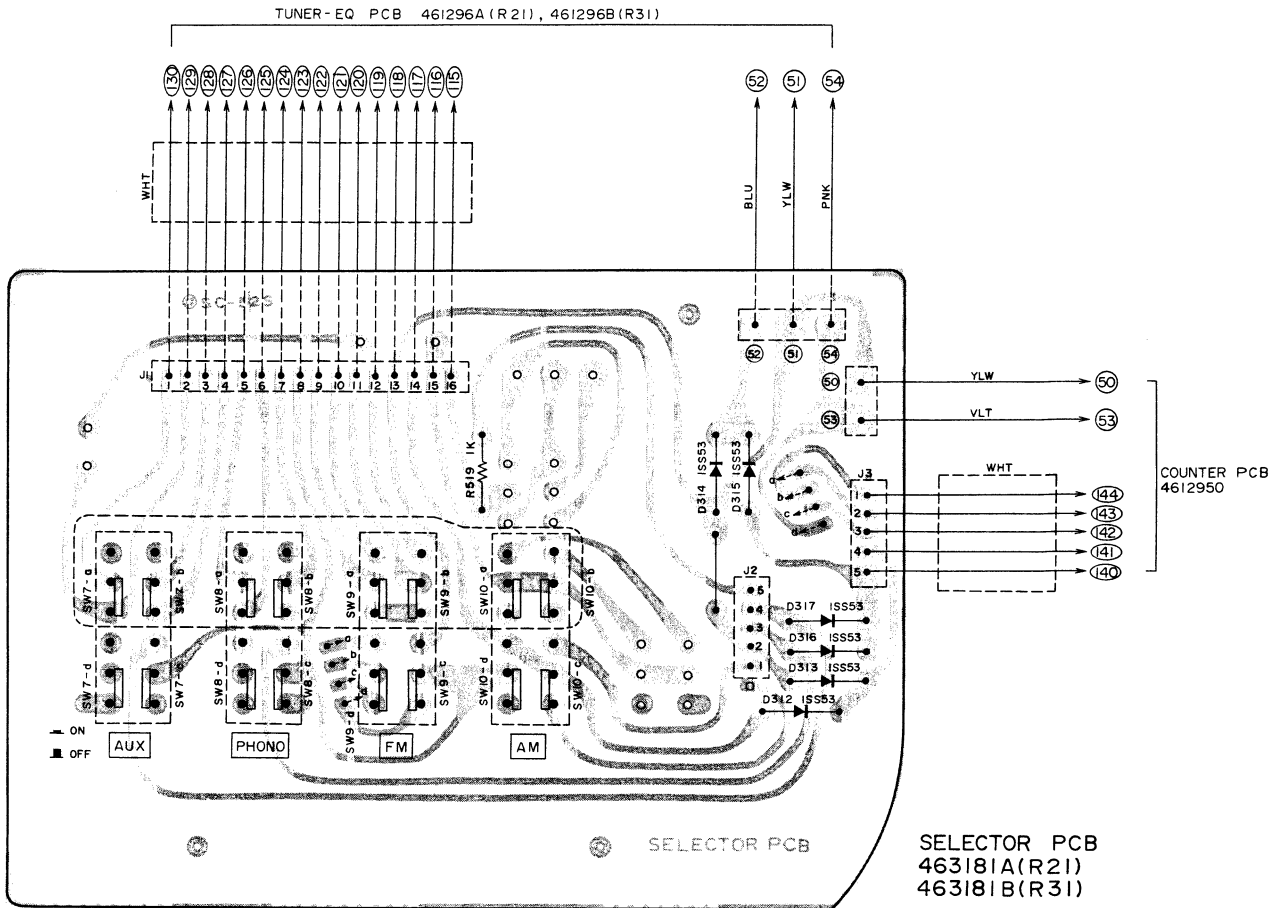

5) COUNTER P.C BOARD 4612950, LED P.C BOARD (S) 4612990 and SUB P.C BOARD (L) 4613030

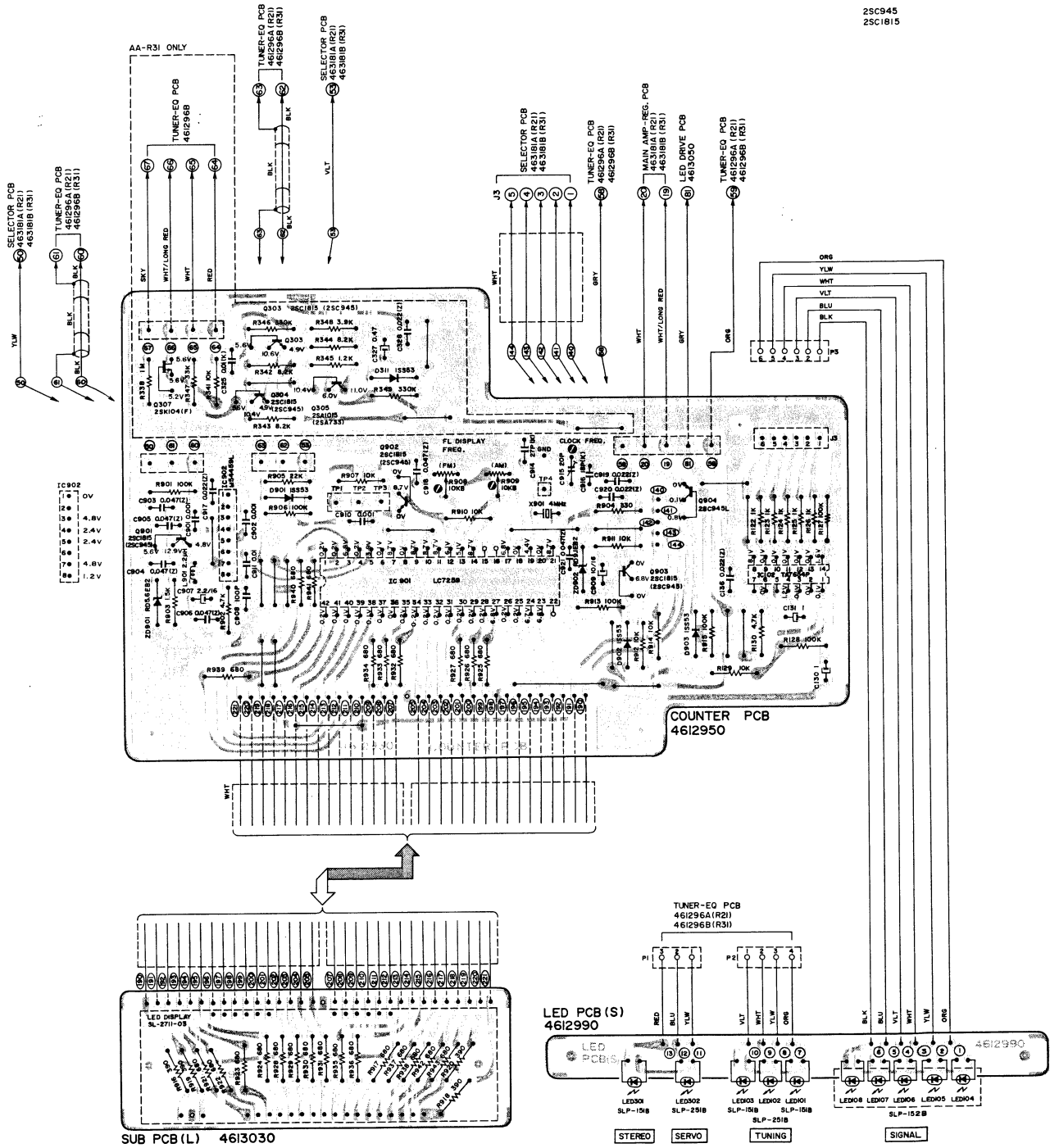

6) LED DRIVE P.C BOARD 4613050

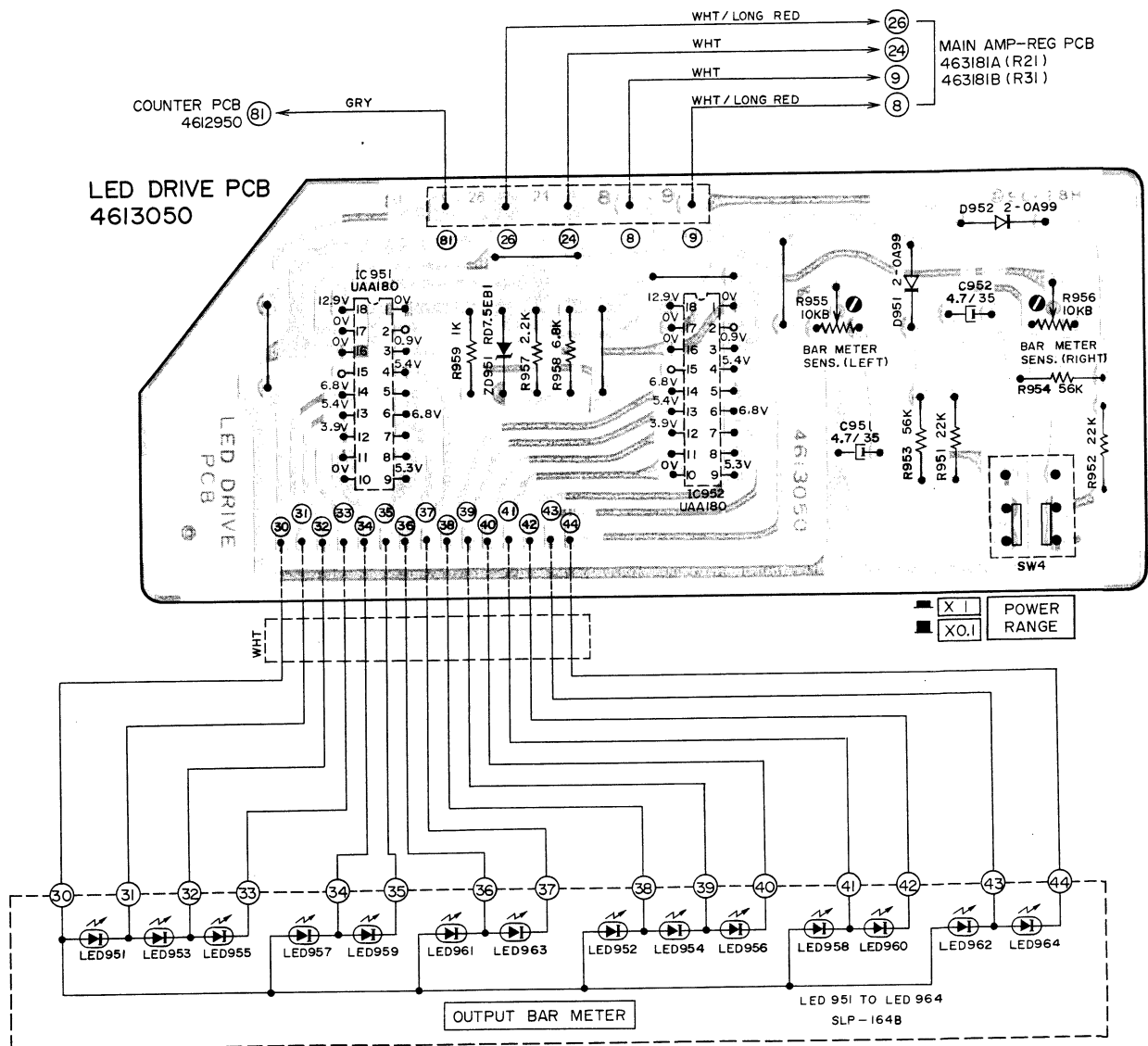

7) POWER SWITCH P.C BOARD 4631820

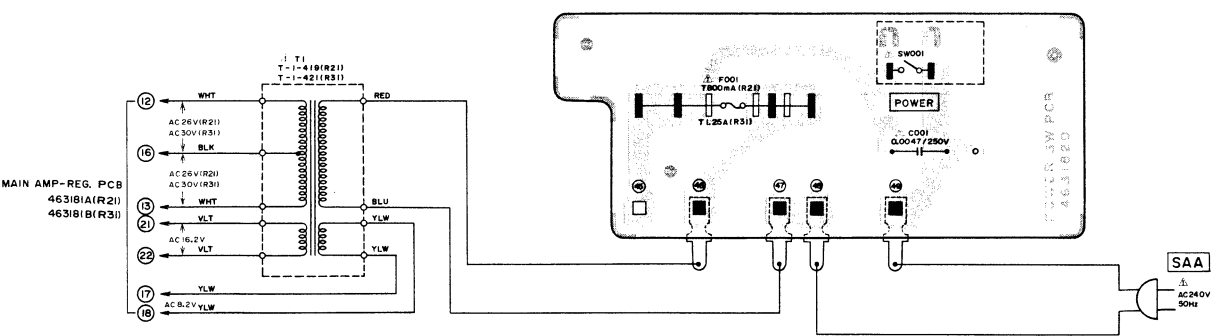
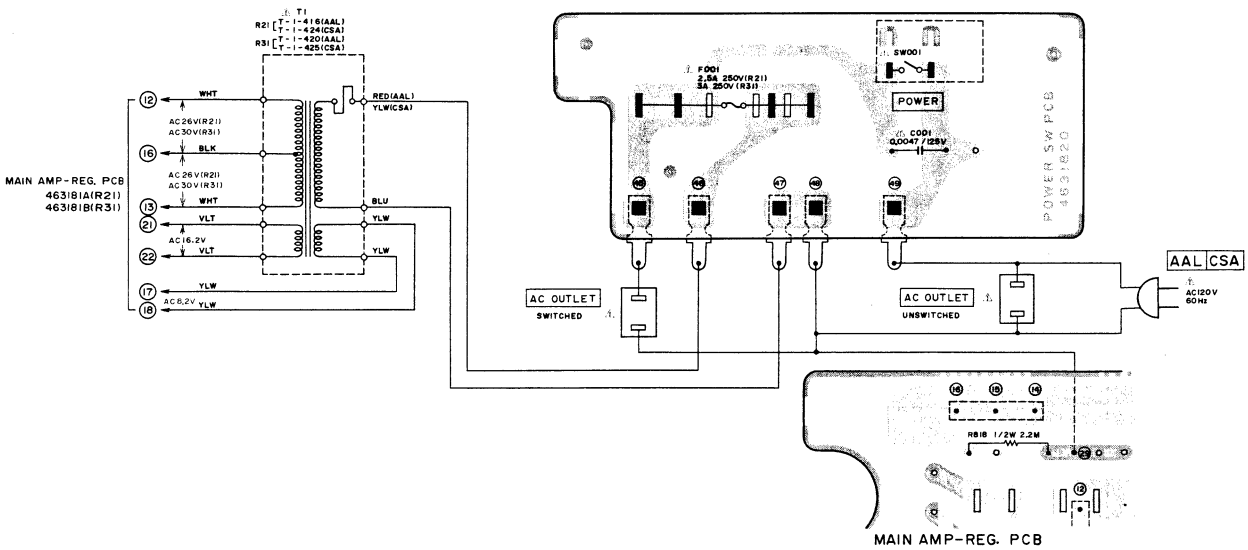
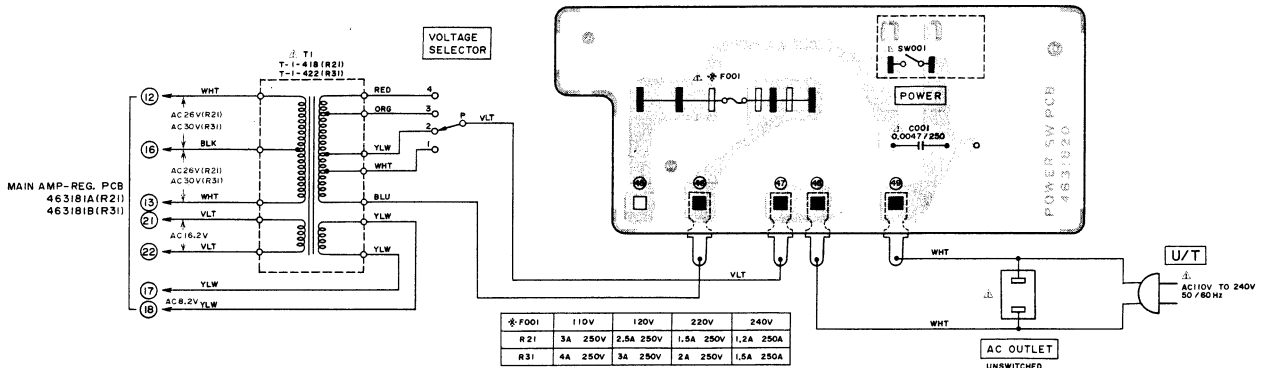

WARNING: Δ INDICATES SAFETY CRITICAL COMPONENTS. FOR CONTINUED SAFETY, REPLACE SAFETY CRITICAL COMPONENTS ONLY WITH MANUFACTURER'S RECOMMENDED PARTS

AVERTISSEMENT: Δ IL INDIQUE LES COMPOSANTS CRITIQUES DE SÛRETÉ. POUR MAINTENIR LE DEGRÉ DE SÛRETÉ DE L'APPAREIL, NE REMPLACER LES COMPOSANTS DONT LE FONCTIONNEMENT EST CRITIQUE POUR LA SÛRETÉ QUE PAR DES PIÈCES RECOMMANDÉES PAR LE FABRICANT

SECTION 2

PARTS LIST

TABLE OF CONTENTS

1. RECOMMENDED SPARE PARTS LIST	34
2. TUNER P.C BOARD BLOCK	36
3. MAIN AMP P.C BOARD BLOCK	36
4. COUNTER P.C BOARD BLOCK	37
5. LED DRIVE P.C BOARD BLOCK	37
6. ASSEMBLY BLOCK	38
7. FINAL ASSEMBLY BLOCK	40
INDEX	41

Resistor and Capacitor which is not listed in this parts list, please refer to COMMON LIST FOR SERVICE PARTS.

HOW TO USE THIS PARTS LIST

1. This parts list is compiled by various individual blocks based on assembly process.
2. When ordering parts, please describe parts number, serial number, and model number in detail.
3. How to read List

The reference number corresponds with illustration or photo number of that particular parts list.

This number corresponds with the Figure Number.

This number corresponds with the individual parts index number in that figure.

A small "x" indicates the inability to show that particular part in the Photo or Illustration.

Schematic Diagram Number of individual manufactured part.
(not required for parts order)

Quantity of particular part required.

Ref. No.	Parts No.	Description	Schematic No.	Q'ty
FLYWHEEL BLOCK #13				
12-115x	800425	Flywheel Block Assy. Comp.	RDG #13	1
12-116	244506	Flywheel Only	RD-233	1
12-117x	244754	Felt, Flywheel	RD-275	1
12-118	251324	Main Metal Case	RD-236	1
12-119	253080	Main Metal	RD-237	1

4. The symbol numbers shown on the P.C. Board list can be matched with the Composite Views of Components of the Schematic Diagram or Service Manual.
5. Please utilize separate "Common List for Service Parts" for Resistor Parts orders.
6. The shape of the parts and parts name, etc. can be confirmed by comparing them with the parts shown on the Electrical Parts Table of P.C. Board.
7. Both the kind of part and installation position can be determined by the Parts Number. To determine where a parts number is listed, utilize Parts Index at end of Parts List.
It is necessary first of all to find the Parts Number. This can be accomplished by using the Reference Number listed at right of parts number in the Parts Index. (meaning of ref. no. outlined in Item 3 above).
8. Utilize separate "Price List for Parts" to determine unit price. The most simple method of finding parts Price is to utilize the reference number.

CAUTION:

1. When placing an order for parts, be sure to list the parts no. model no., and description. There are instances in which if any of this information is omitted, parts cannot be shipped or the wrong parts will be delivered.
2. Please be careful not to make a mistake in the parts no. If the parts no. is in error, a part different from the one ordered may be delivered.
3. Because parts number and parts unit supply in the Preliminary Service Manual (Basic Parts List) may be partially changed, please use this parts list for all future reference.

WARNING: \triangle INDICATES SAFETY CRITICAL COMPONENTS. FOR CONTINUED SAFETY, REPLACE SAFETY CRITICAL COMPONENTS ONLY WITH MANUFACTURER'S RECOMMENDED PARTS.

AVERTISSEMENT: \triangle IL INDIQU LES COMPOSANTS CRITIQUES DE SURETE. POUR MAINTENIR LE DEGRE DE SECURITE DE L'APPAREIL NE REMPLACER LES COMPOSANTS DONT LE FONCTIONNEMENT EST CRITIQUE POUR LA SECURITE QUE PAR DES PIECES RECOMMANDEES PAR LE FABRICANT.

AC INLET SYSTEM

This model is equipped with an AC INLET SYSTEM. Please refer to the AC INLET SYSTEM CHART below for the specific type. By the AC INLET SYSTEM, AC (mains) cord can be connected to and disconnected from the model because the model is provided with socket exclusively for AC (mains) cord on its main body. Please note, however, that certain models are not equipped with this system and has a built-in AC (mains) cord as before.

AC INLET SYSTEM CHART

CLASS I

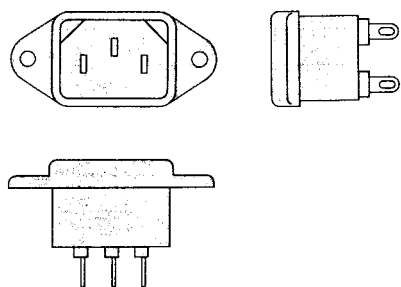

Picture 1
AC INLET
to be
installed
on machines

CLASS II

☐ This mark indicating double insulation will be attached to machine's rear panel

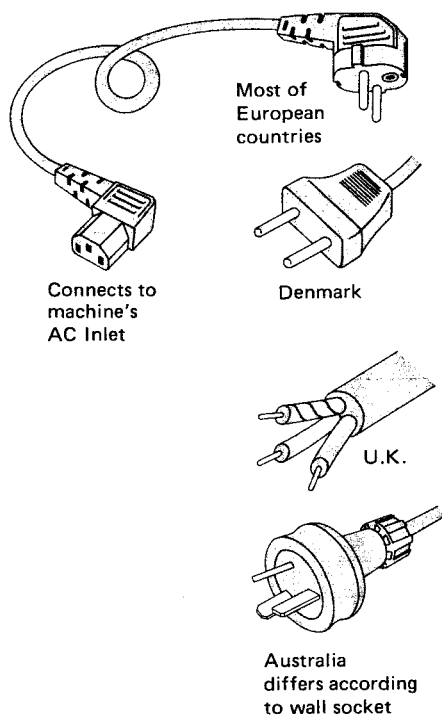
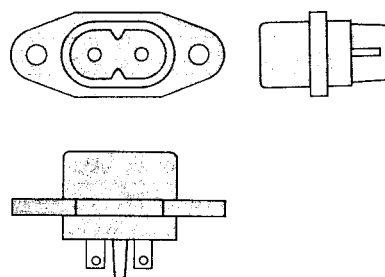

Picture 2
AC (mains)
cord

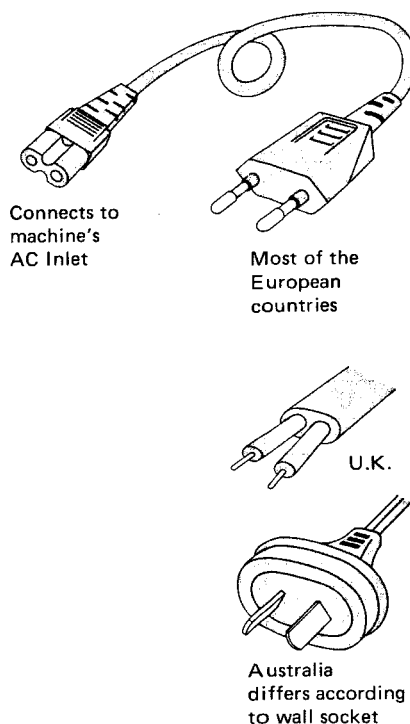

Parts List for AC (mains) Cord Set

	Standard	Description	Type of AC Inlet	Parts No.
Class I	CEE	Cord Set CEE (3 cores)	3P	EW302993
	UK	Cord Set UK (3 cores)	3P	EW302994
	SAA	Cord Set SAA (3 cores)	3P	EW302996
	U/T	Cord Set U/T (3 cores)	3P	EW302646
Class II	CEE	Cord Set CEE (2 cores)	2P	EW638144
	UK	Cord Set UK (2 cores)	2P	EW302995
	SAA	Cord Set SAA (2 cores)	2P	EW302991
	U/T	Cord Set U/T (2 cores)	2P	EW302899

1. RECOMMENDED SPARE PARTS LIST

Because, if the parts listed below are on hand, almost any repair can be accomplished, we suggest that you stock these Recommended Spare Parts Items.

Parts No.	Description	Notes
BA701786	Counter PC Assy AA-R21	
BA701787	Counter PC Assy AA-R31	
BA701797	Main Amp PC Assy AA-R21 (A, C, U)	U/T, CSA, AAL
BA701799	Main Amp PC Assy AA-R21 (S)	SAA
BA701798	Main Amp PC Assy AA-R31 (A, C, U)	U/T, CSA, AAL
BA701800	Main Amp PC Assy AA-R31 (S)	SAA
BA701777	Tuner PC Assy AA-R21 (A, C)	CSA, AAL
BA701781	Tuner PC Assy AA-R21 (S)	SAA
BA701779	Tuner PC Assy AA-R21 (U)	U/T
BA701778	Tuner PC Assy AA-R31 (A, C)	CSA, AAL
BA701782	Tuner PC Assy AA-R31 (S)	SAA
BA701780	Tuner PC Assy AA-R31 (U)	U/T
BT701817	△ Trans Power T-1-416	AAL (AA-R21)
BT701821	△ Trans Power T-1-418	U/T (AA-R21)
BT701822	△ Trans Power T-1-419	SAA (AA-R21)
BT701764	△ Trans Power T-1-420	AAL (AA-R31)
BT701766	△ Trans Power T-1-422	U/T (AA-R31)
BT701767	△ Trans Power T-1-423	SAA (AA-R31)
BT701794	△ Trans Power T-1-424	CSA (AA-R21)
BT701795	△ Trans Power T-1-425	CSA (AA-R31)
EC701725	△ C MMY 472 125DC	U/T, SAA
EC701724	△ C MMY 472 250DC	CSA, AAL
ED701756	D LED SLP 151B RED	
ED701755	D LED SLP 152B RED	
ED701791	D LED SLP 164B	
ED701806	D LED SLP 255B-01	
ED703896	D Silicon GP25D-L	
ED302379	D Silicon H 1SS53	
ED704088	D Silicon W02	
ED704062	D Silicon 1SS55	
ED704108	D Germa 2-0A99	
ED200967	D Zener H RD5.6E B2	
ED704089	D Zener RD13E B3	
ED703883	D Zener RD20E B3	
ED701744	D Zener RD3.9E B1	
ED309869	D Zener RD6.2E B	
ED704104	D Zener RD7.5E B1	
ED322410	D Zener RD9.1E B3	
EE701836	ANT Bar AM	
EE701736	Front End FF132U15	(AA-R21)
EE701737	Front End FF135U12	(AA-R31)
EF701723	△ Fuse EAK T0.80A	SAA
EF701726	△ Fuse EAWK T315mA	SAA
EF704083	△ Fuse 1A 250V U/L	U/T, CSA, AAL
EF700273	△ Fuse 1AT 250V	SAA
EF700286	△ Fuse 2A 250V	U/T

Parts No.	Description	Notes
EF701721	△ Fuse 250V 1.50A	U/T
EF701720	△ Fuse 250V 2.50A	CSA, AAL
EF703830	△ Fuse 3A 250V U/L	CSA, AAL
EF703906	△ Fuse 4A 250V U/L	U/T, CSA, AAL
EI703843	IC HA11225	
EI299700	IC HA1197	
EI701742	IC HA12016	
EI701856	IC LB1450	
EI328850	IC LC7259	
EI701740	IC MPD4069C	
EI328849	IC M54459L	
EI701770	IC TA7654P	
EI704102	IC UAA180	
EI701768	OSC X'TAL HC-18U 4MHz	
EJ701835	△ Socket Outlet	
EJ700279	△ SW Selector	U/T
EM701788	IND FL SL-2711-03	
EP701729	Relay FBR323D024	
ES701719	△ SW Push ESB-7041S	U/T, SAA
ES701718	△ SW Push ESB-70405T	CSA, AAL
ES701716	SW Push	
ES701710	SW Push SUF23	
ES701772	SW Push SUF43	
ES701734	SW Push SUF53	
ET701771	TR FET 2SK104 F	
ET325501	TR 2SA1015 (O) (Y)	
ET308867	TR 2SA1015 (O) (Y) (GR)	
ET703875	TR 2SA798	
ET703878	TR 2SA817	
ET703887	TR 2SA965	
ET704040	TR 2SA970 (GR) (BL)	
ET703873	TR 2SB686	
ET703879	TR 2SB688	
ET703874	TR 2SC1627	
ET701738	TR 2SC1674	
ET703844	TR 2SC1675	
ET307234	TR 2SC1815 (Y) (GR)	
ET703881	TR 2SC2229	
ET307195	TR 2SC2240 (GR) (BL)	
ET703854	TR 2SC945 (L)	
ET701743	TR 2SD655 (E) (F)	
ET703867	TR 2SD716	
ET703872	TR 2SD718	
ET703894	TR 2SD880	
EW701832	△ AC Cord	SAA
EW703828	△ AC Cord	U/T, CSA, AAL

2. TUNER P.C BOARD BLOCK

Symbol No.	Parts No.	Description	Schematic No.
2-1	BA701779	Tuner PC Assy AA-R21(U) (U/T)	9493600
2-2	BA701777	Tuner PC Assy AA-R21(A,C)(CSA,AAL)	9493590
2-3	BA701781	Tuner PC Assy AA-R21(S) (SAA)	9493700
2-4	BA701780	Tuner PC Assy AA-R31(U) (U/T)	9493620
2-5	BA701778	Tuner PC Assy AA-R31(A,C)(CSA,AAL)	9493610
2-6	BA701782	Tuner PC Assy AA-R31(S) (SAA)	9493710
2-7	EE701736	Front End FF132U15 (AA-R21)	4910210
2-8	EE701737	Front End FF135U12 (AA-R31)	4910230
2-IC101	EI703843	IC HA11225	518070S
2-IC103	EI701856	IC LB1450	518114S
2-IC201	EI299700	IC HA1197	45-8-218
2-IC301	EI701742	IC HA12016	518109S
2-IC302	EI701740	IC MPD4069C	518072S
2-Q101	ET703844	TR 2SC1675	515082S
2-Q102	ET701738	TR 2SC1674	515083S
2-Q103	ET307234	TR 2SC1815(Y)(GR)	45-1-299
2-Q301,302	ET701743	TR 2SD655(E)(F)	513115S
2-Q401,402	ET704040	TR 2SA970(GR)(BL)	510103S
2-Q403,404	ET703854	TR 2SC945(L)	515077S
2-Q306	ET307234	TR 2SC1815(Y)(GR)	45-1-299
2-D101,102	ED302379	D Silicon H 1SS53	45-3-43
2-D301to306	ED302379	D Silicon H 1SS53 (AA-R21)	45-3-43
2-D309	ED302379	D Silicon H 1SS53 (AA-R21)	45-3-43
2-D301to310	ED302379	D Silicon H 1SS53 (AA-R31)	45-3-43
2-ZD301	ED701744	D Zener RD3.9EB1	502085S
2-ZD302	ED309869	D Zener H RD6.2E B	45-6-72
2-ZD401	ED703883	D Zener RD20E B3	502069S
2-SW6	ES701734	SW Push SUF53	4041720
2-T101	EO701739	Coil FM DET 1037D	1240450
2-T201	EO703808	Coil OSC AM	1220060
2-T202	EO701747	Coil IFT AM	1230200
2-T203	EO701852	Coil DET AM	1230210
2-L101,102	EO703849	Coil RC-855 2.2μH M	1210860
2-CF101	ER701751	Filter CE KMFC200-M	128072A
2-CF201	ER701753	Filter CE AM SFZ470A	1280630
2-LF301,302	ER701745	Filter LC FB22F01	1280710
2-C136	EC249794	C EC V CUT 04W 102 16.0DC	24-12-16
2-C202	EC701854	C STY V 361J 50DC	223361V
2-C304	EC469708	C STY V 102J 50DC	24-11-3
2-C311,312	EC435690	C STY V 561J 50.0DC	24-11-3
2-R114	EV483377	R S-Fix H SR19R 3P 0.15W 473	36-19-10
2-R211	ER668586	R CB H FS RDS 1/2W 470J	35-11-13
2-R212	ER668564	R CB H FS RDS 1/2W 151J	35-11-13
2-R301	ER668586	R CB H FS RDS 1/2W 470J	35-11-13
2-R303	EV701746	R S-Fix H1021A010 B332	4301320
2-R315	EV310090	R S-Fix H SR19R 3P 0.15W 474	36-19-10
2-R507	EV703841	VR Rotary 254MN	4321010
2-R513	EV703885	VR Rotary 254B	4320990
2-9	EJ703842	Pin J	4444070
2-10	EJ701735	Connector DIN M0088 5P	4530580

3. MAIN AMP P.C BOARD BLOCK

Symbol No.	Parts No.	Description	Schematic No.
3-1	BA701797	Main Amp PC Assy AA-R21(A,C,U) (U/T, CSA, AAL)	9431140
3-2	BA701799	Main Amp PC Assy AA-R21(S) (SAA)	9431160
3-3	BA701798	Main Amp PC Assy AA-R31(A,C,U) (U/T, CSA, AAL)	9431170
3-4	BA701800	Main Amp PC Assy AA-R31(S) (SAA)	9431190
3-Q701,702	ET703875	TR 2SA798	514086S
3-Q703,704	ET307234	TR 2SC1815(Y)(GR)	45-1-299
3-Q705,706	ET703881	TR 2SC2229	512108S
3-Q707,708	ET703854	TR 2SC945(L)	515077S
3-Q709,710	ET703874	TR 2SC1627	511017S
3-Q711,712	ET703878	TR 2SA817 (AA-R21)	510047S
3-Q711,712	ET703887	TR 2SA965 (AA-R31)	510106S
3-Q713,714	ET703867	TR 2SD716 (AA-R21)	513114S
3-Q713,714	ET703872	TR 2SD718 (AA-R31)	513106S
3-Q715,716	ET703873	TR 2SB686 (AA-R21)	511113S
3-Q715,716	ET703879	TR 2SB688 (AA-R31)	511106S
3-Q717	ET307195	TR 2SC2240(GR)(BL)	45-1-302
3-Q801,802	ET307234	TR 2SC1815(Y)(GR)(SAA)	45-1-299
3-Q803	ET325501	TR 2SA1015(O)(Y) (SAA)	45-1-328
3-Q804	ET307234	TR 2SC1815(Y)(GR)(SAA)	45-1-299
3-Q805	ET325501	TR 2SA1015(O)(Y) (SAA)	45-1-328
3-Q806	ET307234	TR 2SC1815(Y)(GR)(SAA)	45-1-299
3-Q807	ET703874	TR 2SC1627 (SAA)	511017S
3-Q851	ET703894	TR 2SD880	513106S
3-D312to317	ED302379	D Silicon H 1SS53	45-3-43
3-D701,702	ED704062	D Silicon 1SS55	5101024S
3-D703	ED302379	D Silicon H 1SS53	45-3-43
3-D801,802	ED704062	D Silicon 1SS55 (SAA)	501024S
3-D803to805	ED302379	D Silicon H 1SS53 (SAA)	45-3-43
3-D806	ED704062	D Silicon 1SS55 (SAA)	501024S
3-D851to854	ED703896	D Silicon GP25D-L	560062S
3-D855,856	ED704088	D Silicon W02	560061S
3-ZD701	ED704089	D Zener RD13E B3	502063S
3-ZD851	ED704089	D Zener RD13E B3	502063S
3-SW2	ES701710	SW Push SUF23 (AA-R21)	4041690
3-SW8	ES701772	SW Push SUF43	4041710
3-RY801	EP701729	Relay FBR323D024(SAA)	1700370
3-L701,702	EO701714	Coil CH	1210960
3-C804	EC701731	C EC NP 101M 16.0DC (SAA)	215230C
3-C852,853	EC703902	C EC V 682 42V (AA-R21)	217947Q
3-C852,853	EC703898	C EC V 822 45V (AA-R31)	2100090
3-C854	EC316184	C EC V CUT H 102M 25.0DC	24-12-46
3-R725,726	ER302240	R CB H SNP FS RDS 1/2W 222J	35-11-27
3-R727,728	ER704091	R CB FS 1/2W 332	329332L
3-R737to740	ER664852	R CB H RD 1/4W 221J	35-11-12
3-R741to744	ER653567	R CT W SW R47K	35-16-3
3-R745,746	ER281338	R OMF H FS 2W 100J	35-19-2
3-R747,748	ER658124	R OMF H FS 1W 100J	35-19-1
3-R749	ER651532	R CB H FS RDS 1/2W 101J (AA-R21)	35-11-13
3-R749	ER704039	R CB 1/2W 470 (AA-R31)	329470L
3-R750	ER651532	R CB H FS RDS 1/2W 101J	35-11-13
3-R773	ER669330	R CB H FS RDS 1/2W 102J	35-11-13
3-R774	ER675077	R CB H FS RDS 1/2W 152J	35-11-13
3-R775,776	ER703871	R OMF 1W 151	361151L
3-R781	EV701712	VR GM70EF60E-104X2(S) (AA-R21)	4321210
3-R781	EV703880	VR Rotary 104C (AA-R31)	4321000
3-R783	EV701713	VR GM70EF61E-104X2(O) (AA-R21)	4321220
3-R783	EV703880	VR Rotary 104C (AA-R31)	4321000
3-R785	ER281305	R CB H FS RD 1/4W 330J	35-11-12
3-R851	ER672221	R CB H FS RDS 1/2W 331J (SAA) (AA-R21)	35-11-13

When ordering parts, please quote Parts Number, Description and Model Number.

Symbol No.	Parts No.	Description	Schematic No.
3-R852	ER666854	R CB H FS RDS 1/2W 221J (SAA) (AA-R21)	35-11-13
3-R815,816	ER672221	R CB H FS RDS 1/2W 331J (SAA) (AA-R31)	35-11-13
3-R851	ER313774	R OMF H FS 1W 472J	35-19-1
3-R852	ER301461	R CB H FS RD 1/4W 471J	35-11-12
3-5	EJ703868	Phone J	4550260
3-6	EJ701769	Socket Jumper V-D0616	4570510
3-7	EJ323264	Socket Jumper W-D0605 5P	31-1-253

4. COUNTER P.C BOARD BLOCK

Symbol No.	Parts No.	Description	Schematic No.
4-1	BA701786	Counter PC Assy AA-R21	9493650
4-2	BA701787	Counter PC Assy AA-R31	9493660
4-IC102	EI701770	IC TA7654P	518090S
4-IC901	EI328850	IC LC7259	45-8 582
4-IC902	EI328849	IC M54459L	45-8 583
4-Q303,304	ET307234	TR 2SC1815(Y)(GR) (AA-R31)	45-1-299
4-Q305	ET308867	TR 2SA1015(O)(Y)(GR) (AA-R31)	45-1-328
4-Q307	ET701771	TR FET 2SK104 F (AA-R31)	516026S
4-Q901to903	ET307234	TR 2SC1815(Y)(GR)	45-1-299
4-Q904	ET703854	TR 2SC945(L)	515077S
4-D311	ED302379	D Silicon H 1SS53 (AA-R31)	45-3-43
4-D901to903	ED302379	D Silicon H 1SS53	45-3-43
4-ZD901	ED200967	D Zener H RD5.6E B2	45-6-72
4-ZD902	ED322410	D Zener RD9.1E B3	45-6-72
4-X901	EI701768	OSC X'TAL HC-18U 4MHz	1280650
4-L901	EO703849	Coil RC-855 2.2μH M	1210860
4-C915	EC701790	C S-Fix ECV1ZW 200	4241060
4-R908,909	EV483388	R S-Fix H SR19R 3P 0.15W 103	36-19-10
4-3	EM701788	IND FL SL-2711-03	5060360

5. LED DRIVE P.C BOARD BLOCK

Symbol No.	Parts No.	Description	Schematic No.
5-IC951,952	EI704102	IC UAA180	518066S
5-D951,952	ED704108	D Germa 2-0A99	500014G
5-ZD951	ED704104	D Zener RD7.5E B1	502062S
5-LED951	ED701791	D LED SLP 164B to 964	5060400
5-SW4	ES701716	SW Push	4041680
5-R955,956	EV704107	R S-Fix SR29R 103	4301220
5-1	ZW703815	RV NYL30x055	7400840

6. ASSEMBLY BLOCK

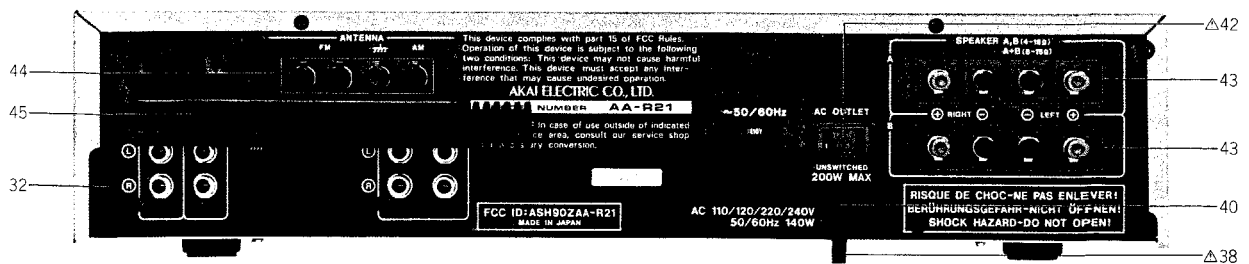
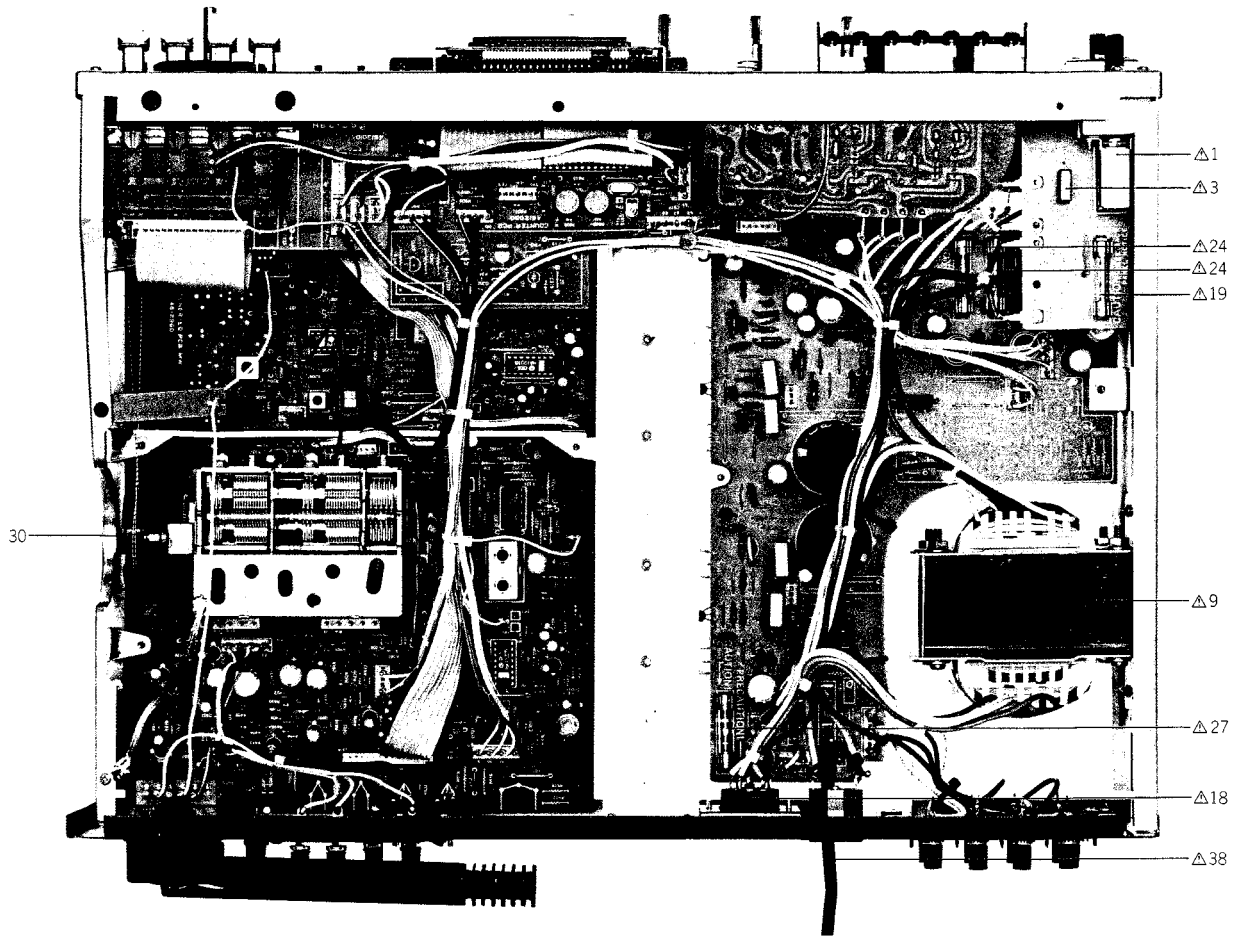

ASSEMBLY BLOCK

Ref. No.	Parts No.	Description	Schematic No.	Ref. No.	Parts No.	Description	Schematic No.
POWER SW PC BLK				6-45	EE701836	ANT Bar AM	1200400
6-1	ES701719	△ SW Push ESB-70414S (U/T, SAA)	4041550	6-46x	ZS701839	GND NUT 1P	4450570
6-2x	ES701718	△ SW Push ESB-70405T (CSA, AAL)	4041780				
6-3	EC701725	△ C MMY 472 125DC (U/T, SAA)	283472M				
6-4x	EC701724	△ C MMY 472 250DC (CSA, AAL)	284472M				
FRONT PLATE BLK							
6-5x	MI701825	Tuning Wheel 2131	7152590				
6-6x	MS703806	Pulley Shaft	7121120				
6-7x	MR703805	Pulley D=9	7400790				
6-8x	ZS701810	RV Push 30x045	7401240				
CHASSIS BLK							
6-9	BT701821	△ Trans Power T-1-418 (U/T) (AA-R21)	1104180				
6-10x	BT701794	△ Trans Power T-1-424 (CSA) (AA-R21)	1104240				
6-11x	BT701817	△ Trans Power T-1-416 (AAL) (AA-R21)	1104160				
6-12x	BT701822	△ Trans Power T-1-419 (SAA) (AA-R21)	1104190				
6-13x	BT701766	△ Trans Power T-1-422 (U/T) (AA-R31)	1104220				
6-14x	BT701795	△ Trans Power T-1-425 (CSA) (AA-R31)	1104250				
6-15x	BT701764	△ Trans Power T-1-420 (AAL) (AA-R31)	1104200				
6-16x	BT701767	△ Trans Power T-1-423 (SAA) (AA-R31)	1104230				
6-17x	ZS304022	ST PAN40x06STL CMT					
6-18	EJ700279	△ SW Selector (U/T)	4530540				
6-19	EF701721	△ Fuse 250V 1.50A (U/T) (AA-R21)	4700610				
6-20x	EF701720	△ Fuse 250V 2.50A (CSA, AAL) (AA-R21)	4700740				
6-21x	EF701723	△ Fuse EAK T0.80A (SAA) (AA-R21)	4720320				
6-22x	EF700286	△ Fuse 2A 250V (U/T)(AA-R31)	4700620				
6-23x	EF703830	△ Fuse 3A 250V U/L (CSA, AAL) (AA-R31)	4700630				
6-24	EF703906	△ Fuse 4A 250V U/L (U/T, CSA, AAL)	4700550				
6-25x	EF704083	△ Fuse 1A 250V U/L (U/T, CSA, AAL)	4700590				
6-26x	EF701726	△ Fuse EAWK T315mA (SAA)	4720500				
6-27	EF704083	△ Fuse 1A 250V U/L (U/T, CSA, AAL)	4700590				
6-28x	EF700273	△ Fuse 1AT 250V (SAA)	4720330				
6-29x	ZS463353	T2BR30x08STL BNI					
6-30	MI701823	Dial Wheel	7400860				
6-31x	ZG701824	SP (R)	7440380				
REAR PANEL BLK							
6-32	SP701828	Panel Rear AA-R21(U) (U/T)	7326770				
6-33x	SP701826	Panel Rear AA-R21(A,C) (CSA, AAL)	7326730				
6-34x	SP701829	Panel Rear AA-R21(S) (SAA)	7326790				
6-35x	SP701844	Panel Rear AA-R31(U) (U/T)	7326780				
6-36x	SP701841	Panel Rear AA-R31(A,C) (CSA, AAL)	7326740				
6-37x	SP701845	Panel Rear AA-R31(S) (SAA)	7326800				
6-38	EW703828	△ AC Cord (U/T, CSA, AAL)	606007A				
6-39x	EW701832	△ AC Cord (SAA)	600516A				
6-40	EZ703829	Strain Relief SR-3P-4 (U/T, CSA, AAL)	7400620				
6-41x	EZ701834	Strain Relief SR4N-4 (SAA)	7400690				
6-42	EJ701835	△ Socket Outlet	4500190				
6-43	EJ703832	Speaker Terminal	4450470				
6-44	EJ703834	ANT Terminal	4450440				

When ordering parts, please quote Parts Number, Description and Model Number.

7. FINAL ASSEMBLY BLOCK

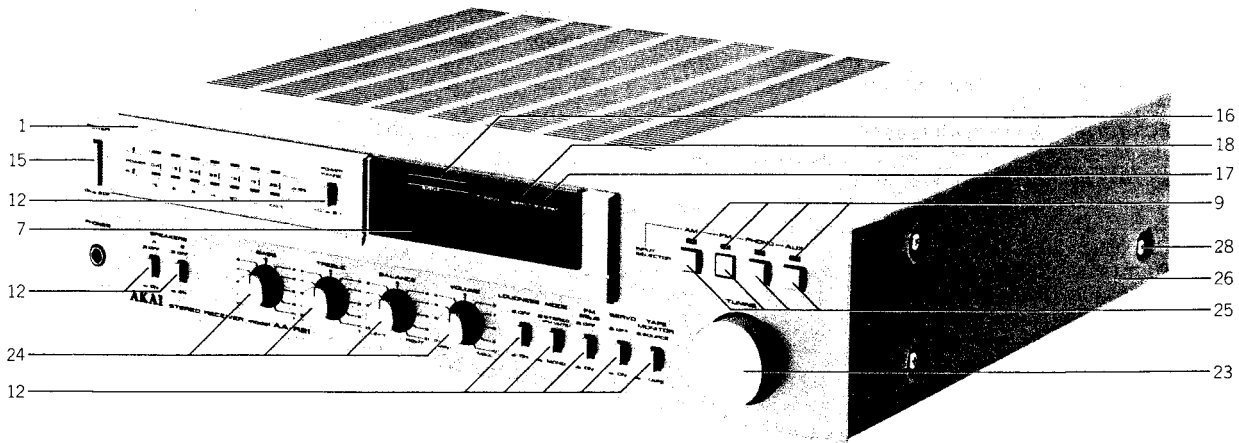

FINAL ASSEMBLY BLOCK

Ref. No.	Parts No.	Description	Schematic No.
7-1	BD701848	Panel Front Assy AA-R21(U,S) (U/T, SAA)	7885660
7-2x	BD701846	Panel Front Assy AA-R21(A,C) (CSA, AAL)	7885640
7-3x	BD701851	Panel Front Assy AA-R31(U,S) (U/T, SAA)	7885690
7-4x	BD701849	Panel Front Assy AA-R31(A,C) (CSA, AAL)	7885670
7-5x	SE701840	Escutcheon Panel	7870580
7-6x	ZW302909	RV NYL30x035 BL	2-7-54
7-7	SP701805	Panel Smoke	7403320
7-8x	ZW703815	RV NYL30x055	7400840
7-9	ED701806	D LED SLP 255B-01	5060440
7-10x	EJ701808	Mini Connect Assy 5P	4570660
7-11x	ZS701810	RV Push 30x045	7401240
7-12	SB703817	Button (C) AA-R20	7852130
7-13x	ZG701811	SP C8001	7441410
7-14x	ZW703819	Button Stopper AA-R20	7401460
7-15	SB703794	Button (A) AA-R20	7852120
7-16	ED701755	D LED SLP 152B RED	5060370
7-17	ED701756	D LED SLP 151B RED	5060380
7-18	ED701757	D LED SLP 251B GRN	5060390
7-19x	ZW703815	RV NYL30x055	7400840
7-20x	EJ701812	Mini Connect Assy 3P	4570580
7-21x	EJ701813	Mini Connect Assy 4P	4570590
7-22x	EJ701809	Mini Connect Assy 6P	4570600
7-23	SK701814	Knob RSL-38	7841460
7-24	SK701759	Knob RSL-18D	7852650
7-25	SK701815	Knob 99SQ	7852560
7-26	SP701761	Cover 231G (U/T, SAA)	7821170
7-27x	SP701760	Cover 231 (CSA, AAL)	7821160
7-28	ZS322570	ST BID40x08STL NI3 (U/T,SAA)	7121220
7-29x	ZS322580	ST BID40x08STL BNI (CSA,AAL)	
7-30x	SP701762	Cover Bottom	7326630
7-31x	SA703922	Foot	7402080
7-32x	ZS565942	T2PAN40x08STL CMT	
7-33x	ZS666336	T2PAN30x08STL CMT	

When ordering parts, please quote Parts Number, Description and Model Number.

INDEX

Parts No.	Ref. No. & Symbol No.	Parts No.	Ref. No. & Symbol No.	Parts No.	Ref. No. & Symbol No.	Parts No.	Ref. No. & Symbol No.
BA701777	2-2	EI701742	2-IC301	ET703874	3-Q709,710		
BA701778	2-5	EI701768	4-X901	ET703874	3-Q807		
BA701779	2-1	EI701770	4-IC102	ET703875	3-Q701,702		
BA701780	2-4	EI701856	2-IC103	ET703878	3-Q711,712		
BA701781	2-4	EI703843	2-IC101	ET703879	3-Q715,716		
BA701782	2-6	EI704102	5-IC951,952	ET703881	3-Q705,706		
BA701786	4-1	EJ323264	3-7	ET703887	3-Q711,712		
BA701787	4-2	EJ700279	6-18	ET703894	3-Q851		
BA701797	3-1	EJ701735	2-10	ET704040	2-Q401,402		
BA701798	3-3	EJ701769	3-6	EV310090	2-R315		
BA701799	3-2	EJ701808	7-10x	EV483377	2-R114		
BA701800	3-4	EJ701809	7-22x	EV483388	4-R908,909		
BD701846	7-2x	EJ701812	7-20x	EV701712	3-R781		
BD701848	7-1	EJ701813	7-21x	EV701713	3-R783		
BD701849	7-4x	EJ701835	6-42	EV701746	2-R303		
BD701851	7-3x	EJ703832	6-43	EV703841	2-R507		
BT701764	6-15x	EJ703834	6-44	EV703880	3-R781		
BT701766	6-13x	EJ703842	2-9	EV703880	3-R783		
BT701767	6-16x	EJ703868	3-5	EV703885	2-R513		
BT701794	6-10x	EM701788	4-3	EV704107	5-R955,956		
BT701795	6-14x	EO701714	3-L701,702	EW701832	6-39x		
BT701817	6-11x	EO701739	2-T101	EW703828	6-38		
BT701821	6-9	EO701747	2-T202	EZ701834	6-41x		
BT701822	6-12x	EO701852	2-T203	EZ703829	6-40		
EC249794	2-C136	EO703808	2-T201	MI701823	6-30		
EC316184	3-C854	EO703849	2-L101,102	MI701825	6-5x		
EC435690	2-C311,312	EO703849	4-L901	MR703805	6-7x		
EC469708	2-C304	EP701729	3-RY801	MS703806	6-6x		
EC701724	6-4x	ER281305	3-R785	SA703922	7-31x		
EC701725	6-3	ER281338	3-R745,746	SB703794	7-15		
EC701731	3-C804	ER301461	3-R852	SB703817	7-12		
EC701790	4-C915	ER302240	3-R725,726	SE701840	7-5x		
EC701854	2-C202	ER313774	3-R851	SK701759	7-24		
EC703898	3-C852,853	ER651532	3-R749	SK701814	7-23		
EC703902	3-C852,853	ER651532	3-R750	SK701815	7-25		
ED200967	4-ZD901	ER653567	3-R741to744	SP701760	7-27x		
ED302379	2-D101,102	ER658124	3-R747,748	SP701761	7-26		
ED302379	2-D301to306	ER664852	3-R737to740	SP701762	7-30x		
ED302379	2-D309	ER666854	3-R852	SP701805	7-7		
ED302379	2-D301to310	ER668564	2-R212	SP701826	6-33x		
ED302379	3-D312to317	ER668586	2-R211	SP701828	6-32		
ED302379	3-D703	ER668586	2-R301	SP701829	6-34x		
ED302379	3-D803to805	ER669330	3-R773	SP701841	6-36x		
ED302379	4-D311	ER672221	3-R851	SP701844	6-35x		
ED302379	4-D901to903	ER672221	3-R815,816	SP701845	6-37x		
ED309869	2-ZD302	ER675077	3-R774	ZG701811	7-13x		
ED322410	4-ZD902	ER701745	2-LF301,302	ZG701824	6-31x		
ED701744	2-ZD301	ER701751	2-CF101	ZS304022	6-17x		
ED701755	7-16	ER701753	2-CF201	ZS322570	7-28		
ED701756	7-17	ER703871	3-R775,776	ZS322580	7-29x		
ED701757	7-18	ER704039	3-R749	ZS463353	6-29x		
ED701791	5-LED951to964	ER704091	3-R727,728	ZS565942	7-32x		
ED701806	7-9	ES701710	3-SW2	ZS666336	7-33x		
ED703883	2-ZD401	ES701716	5-SW4	ZS701810	6-8x		
ED703896	3-D851to854	ES701718	6-2x	ZS701810	7-11x		
ED704062	3-D701,702	ES701719	6-1	ZS701839	6-46x		
ED704062	3-D801,802	ES701734	2-SW6	ZW302909	7-6x		
ED704062	3-D806	ES701772	3-SW8	ZW703815	5-1		
ED704088	3-D855,856	ET307195	3-Q717	ZW703815	7-8x		
ED704089	3-ZD701	ET307234	2-Q103	ZW703815	7-19x		
ED704089	3-ZD851	ET307234	2-Q306	ZW703819	7-14x		
ED704104	5-ZD951	ET307234	3-Q703,704				
ED704108	5-D951,952	ET307234	3-Q801,802				
EE701736	2-7	ET307234	3-Q804				
EE701737	2-8	ET307234	3-Q806				
EE701836	6-45	ET307234	4-Q303,304				
EF700273	6-28x	ET307234	4-Q901to903				
EF700286	6-22x	ET308867	4-Q305				
EF701720	6-20x	ET325501	3-Q803				
EF701721	6-19	ET325501	3-Q805				
EF701723	6-21x	ET701738	2-Q102				
EF701726	6-26x	ET701743	2-Q301,302				
EF703830	6-23x	ET701771	4-Q307				
EF703906	6-24	ET703844	2-Q101				
EF704083	6-25x	ET703854	2-Q403,404				
EF704083	6-27	ET703854	3-Q707,708				
EI299700	2-IC201	ET703854	4-Q904				
EI328849	4-IC902	ET703867	3-Q713,714				
EI328850	4-IC901	ET703872	3-Q713,714				
EI701740	2-IC302	ET703873	3-Q715,716				

SECTION 3

SCHEMATIC DIAGRAM

1. SCHEMATIC DIAGRAM OF ICs
2. AA-R21 NO. 2-1 1602236A MAIN, POWER SCHEMATIC DIAGRAM
3. AA-R21 NO. 2-2 1602237A TUNER SCHEMATIC DIAGRAM
4. AA-R31 NO. 2-1 1602238A MAIN, POWER SCHEMATIC DIAGRAM
5. AA-R31 NO. 2-2 1602239A TUNER SCHEMATIC DIAGRAM

HA1197

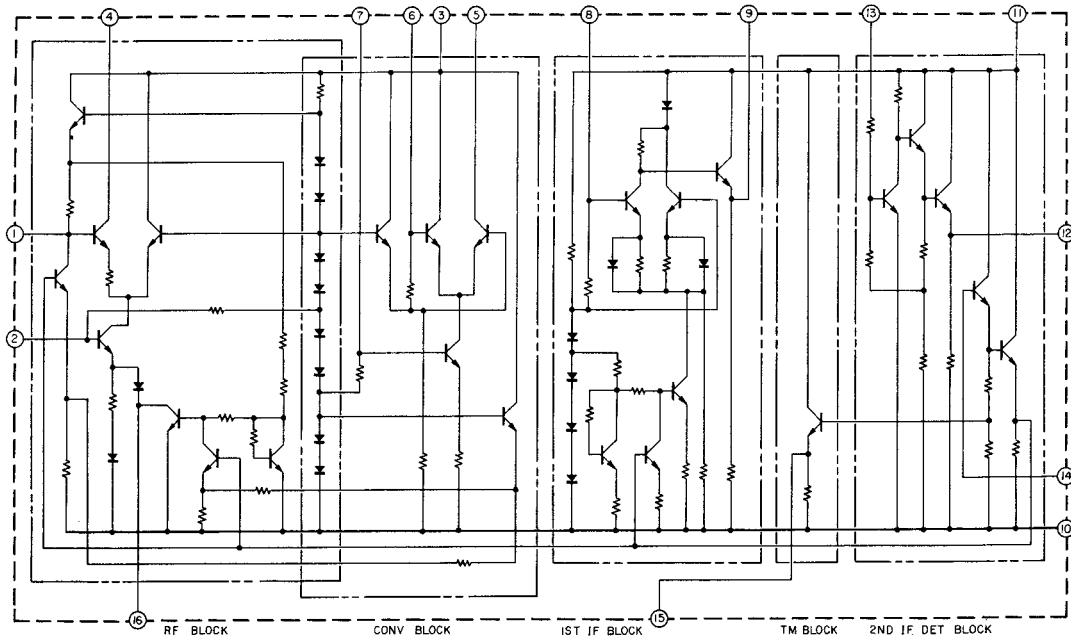

HA11225

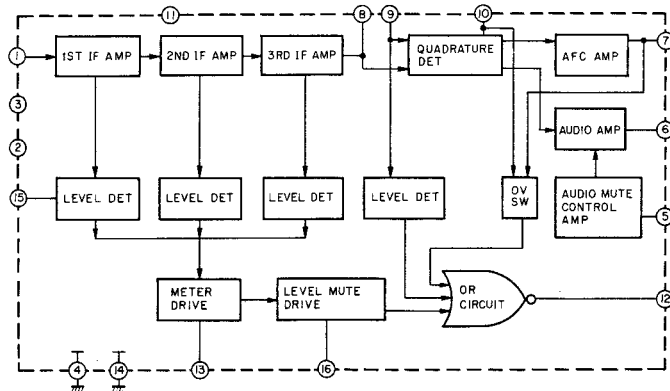

HA12016

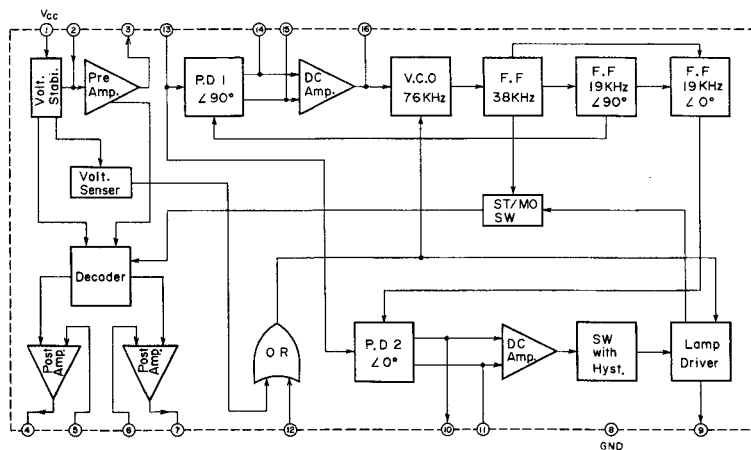

LB1450

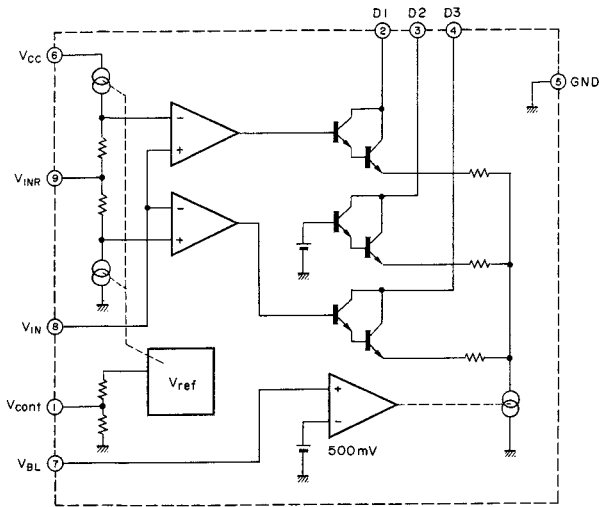

M54459L

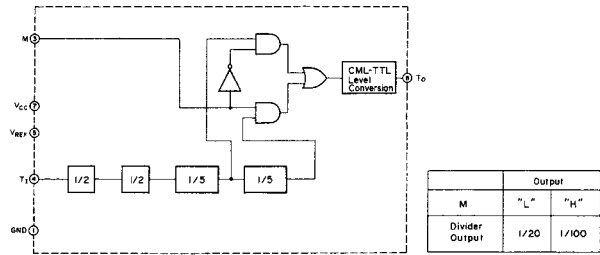

TA7654P

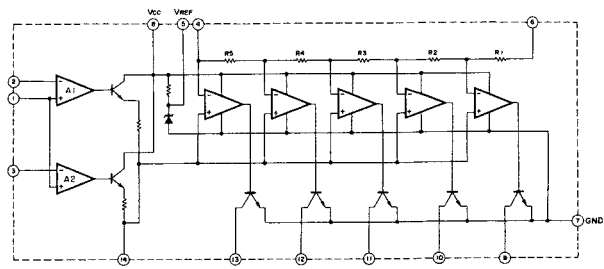

LC7259

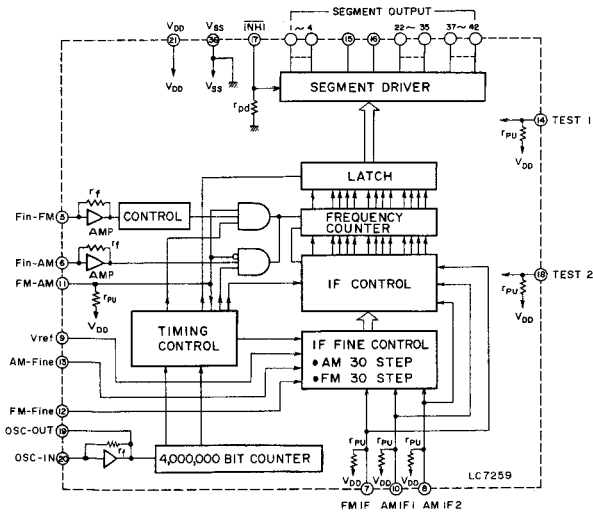

NOTE: rPU is a special-type resistor whose resistance will become the rated value at "H" level, and high at "L" level.

UAA180

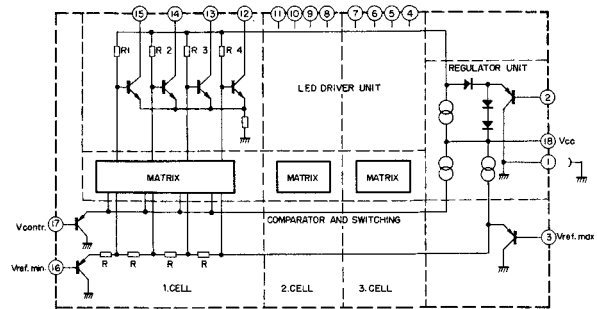

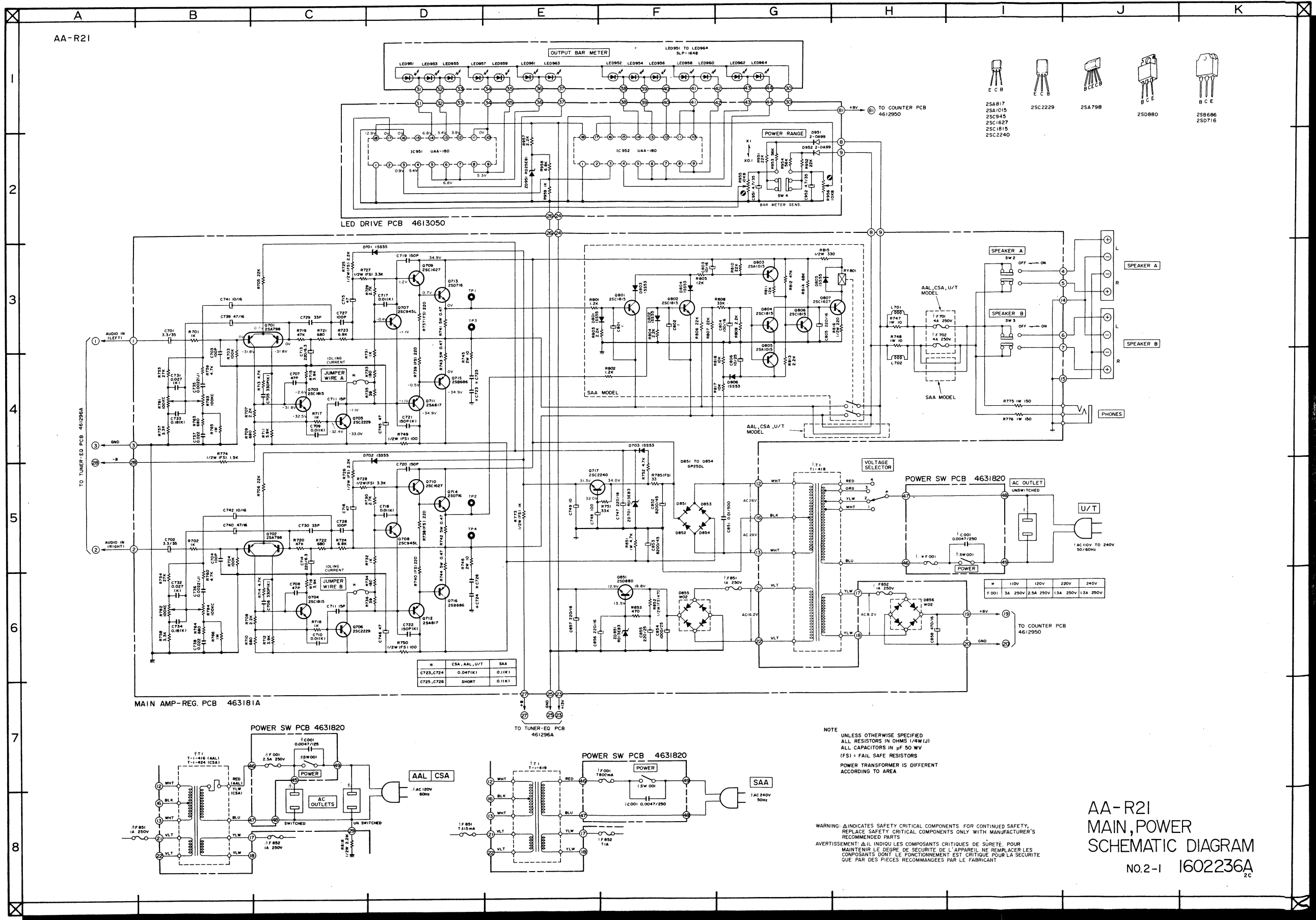

AA-R21
 MAIN, POWER
 SCHEMATIC DIAGRAM
 No.2-1 1602236A
 2C

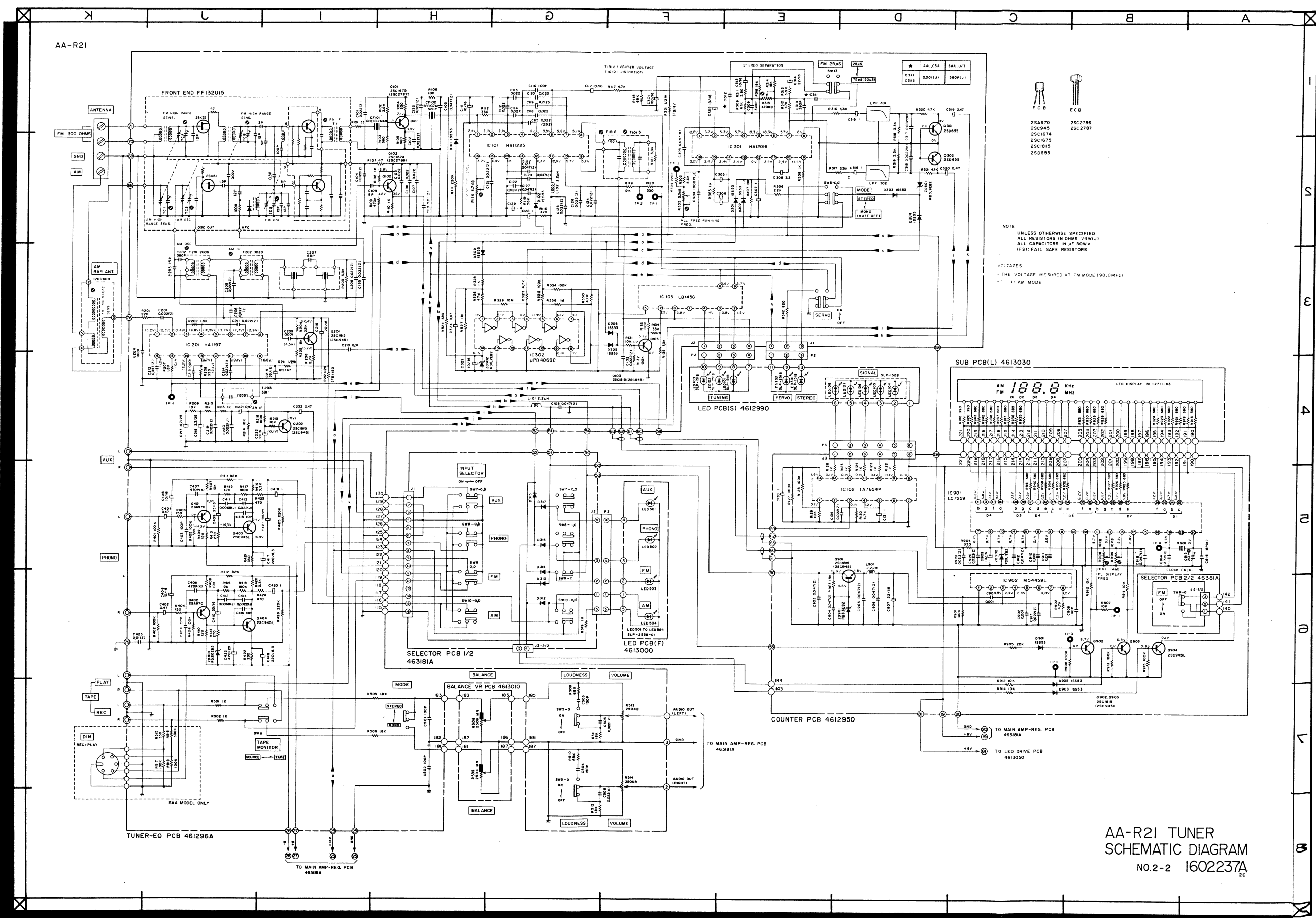

- E C B
 E C B
 25A970
 25C945
 25C1674
 25C1675
 25C1815
 25D655

NOTE
 UNLESS OTHERWISE SPECIFIED
 ALL RESISTORS IN OHMS (1/4W/1J)
 ALL CAPACITORS IN uF 50WV
 (F51) FAIL SAFE RESISTORS

VOLTAGES
 * THE VOLTAGE MEASURED AT FM MODE (98.0MHz)
 † : AM MODE

AA-R21 TUNER
 SCHEMATIC DIAGRAM
 NO.2-2 1602237A

AA-R31

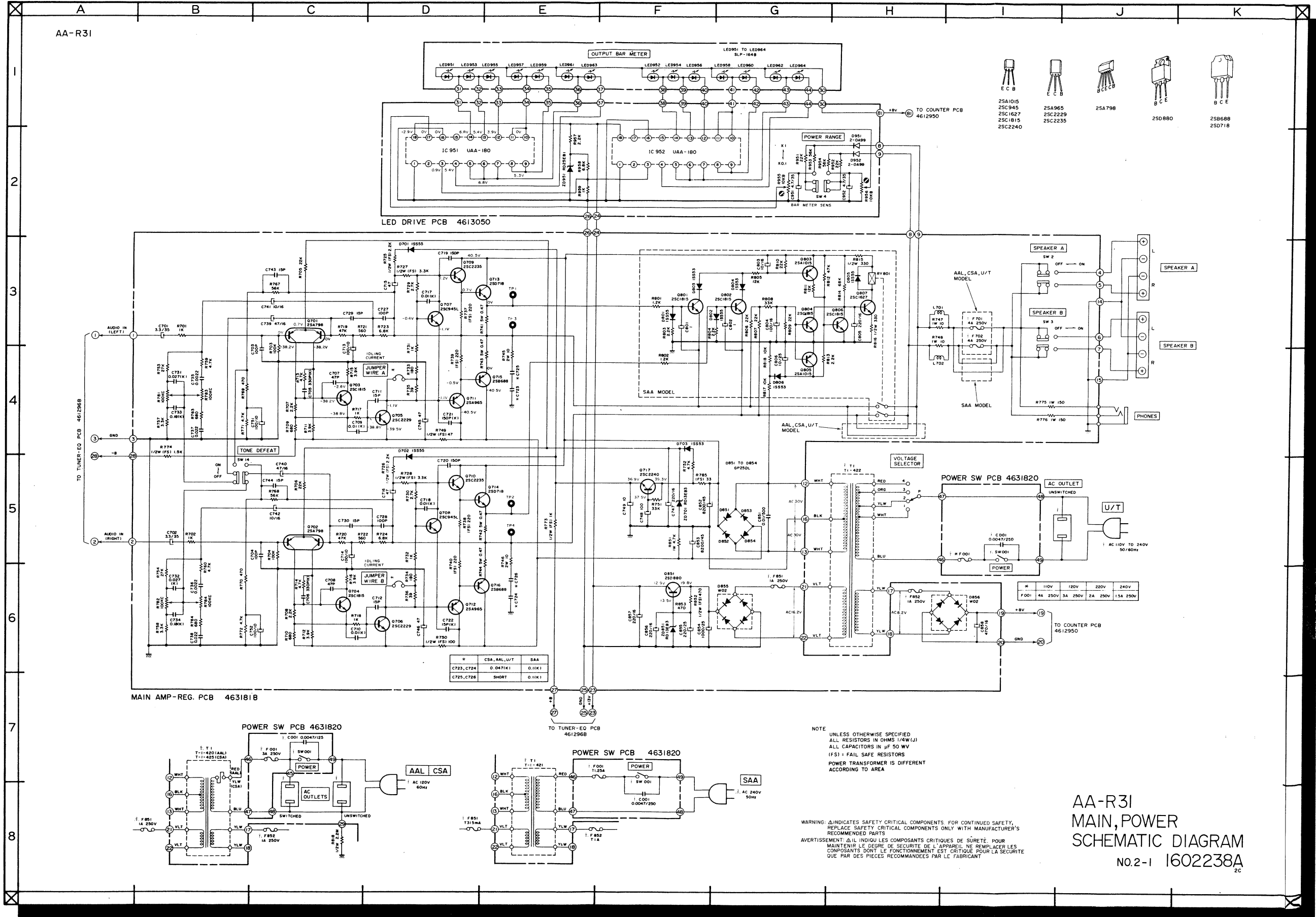

- 25A1015
- 25C945
- 25C1627
- 25C1815
- 25C2240
- 25A965
- 25C2229
- 25C2235
- 25A798
- 25D880
- 25B688
- 25D718

MAIN AMP-REG. PCB 463181B

POWER SW PCB 4631820

POWER SW PCB 4631820

*	CSA, AAL, U/T	SAA
C723, C724	0.047(1K)	0.1(1K)
C725, C726	SHORT	0.1(1K)

NOTE
 UNLESS OTHERWISE SPECIFIED,
 ALL RESISTORS IN OHMS (1/4W U)
 ALL CAPACITORS IN μ F 50 WV
 (FS) = FAIL SAFE RESISTORS
 POWER TRANSFORMER IS DIFFERENT
 ACCORDING TO AREA

WARNING: Δ INDICATES SAFETY CRITICAL COMPONENTS. FOR CONTINUED SAFETY,
 REPLACE SAFETY CRITICAL COMPONENTS ONLY WITH MANUFACTURER'S
 RECOMMENDED PARTS
 AVERTISSEMENT: Δ IL INDIQUE LES COMPOSANTS CRITIQUES DE SURETE. POUR
 MAINTENIR LE DEGRE DE SECURITE DE L'APPAREIL, NE REMPLACER LES
 COMPOSANTS DONT LE FONCTIONNEMENT EST CRITIQUE POUR LA SECURITE
 QUE PAR DES PIECES RECOMMANDEES PAR LE FABRICANT

AA-R31
 MAIN, POWER
 SCHEMATIC DIAGRAM
 NO.2-1 1602238A
 2c

AA-R31

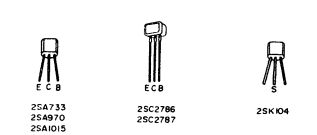
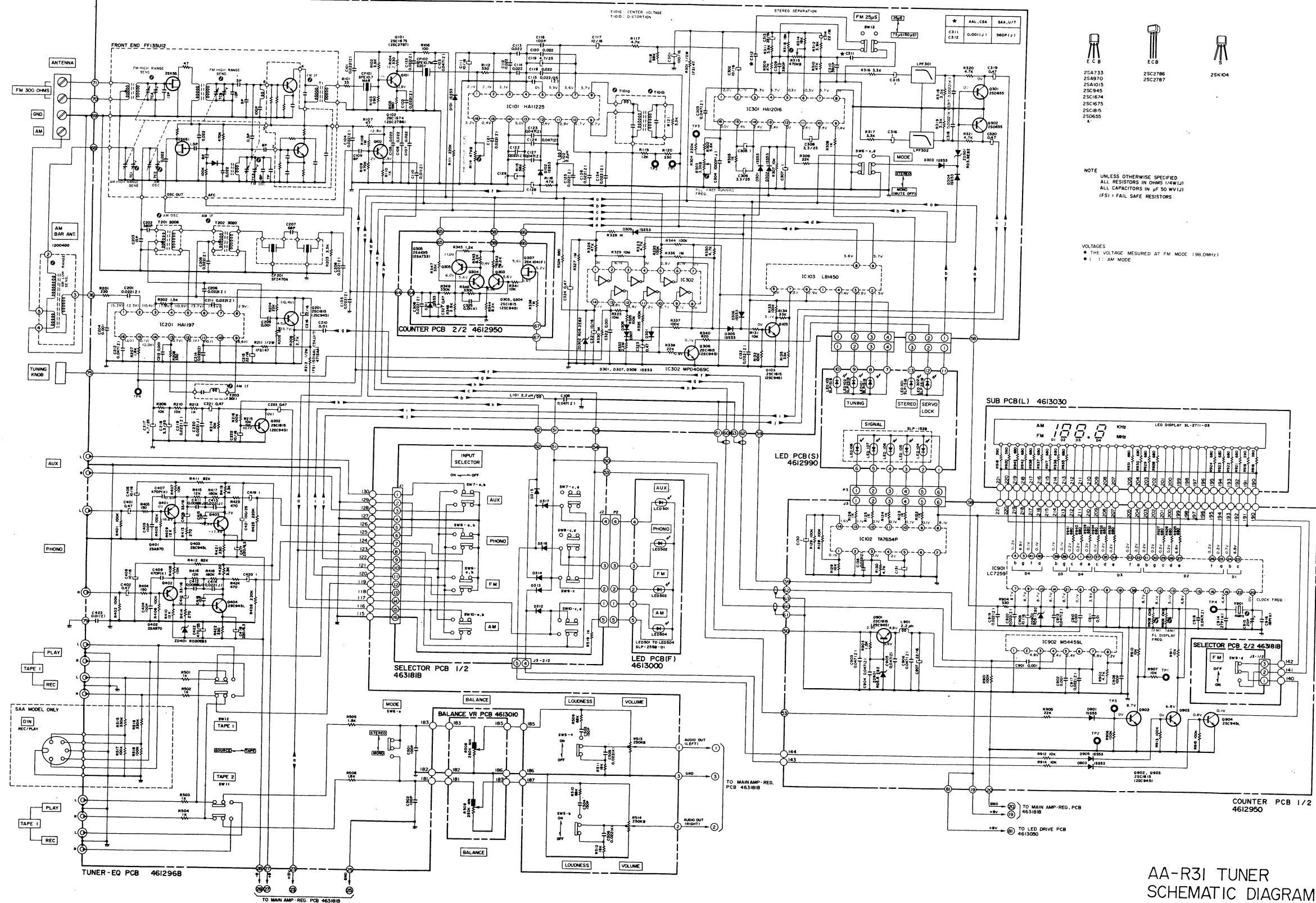

NOTE
UNLESS OTHERWISE SPECIFIED
ALL RESISTORS IN OHMS (AW/L)
ALL CAPACITORS IN pF (50 WV/L)
(FS) = FAIL SAFE RESISTORS

VOLTAGES
• THE VOLTAGE MEASURED AT FM MODE (98.0MHz)
• 1: AM MODE

AA-R31 TUNER
SCHEMATIC DIAGRAM
NO2-2 1602239A
2C