

AA-R40

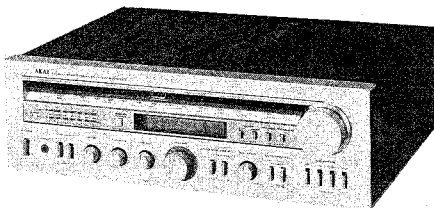

AA-R50

FM AM STEREO RECEIVER

MODEL **AA-R40**

MODEL **AA-R50**

SECTION 1	SERVICE MANUAL	3
SECTION 2	PARTS LIST	29
SECTION 3	SCHEMATIC DIAGRAM	39

SECTION 1

SERVICE MANUAL

TABLE OF CONTENTS

I.	TECHNICAL DATA	4
1.	MODEL AA-R40	4
2.	MODEL AA-R50	5
II.	DISMANTLING OF UNIT	6
III.	CONTROLS	7
IV.	PRINCIPAL PARTS LOCATION	9
V.	BLOCK DIAGRAM	11
VI.	LEVEL DIAGRAM	12
VII.	AMPLIFIER ADJUSTMENT	13
1.	CENTER VOLTAGE ADJUSTMENT	14
2.	IDLING CURRENT ADJUSTMENT	14
3.	POWER INDICATOR LED ADJUSTMENT	14
VIII.	TUNER ADJUSTMENT	15
1.	FM ADJUSTMENT	17
2.	AM ADJUSTMENT	18
IX.	TUNING CORD THREADING	19
X.	CLASSIFICATION OF VARIOUS P.C BOARDS	20
1.	P.C BOARD TITLES AND IDENTIFICATION NUMBERS	20
2.	COMPOSITION OF VARIOUS P.C BOARDS	21

For basic adjustments, measuring methods, and operating principles, refer to GENERAL TECHNICAL MANUAL.

I. TECHNICAL DATA

1. MODEL AA-R40

RATED POWER OUTPUT 2-CHANNEL DRIVEN		50 watts per channel, minimum RMS, at 8 ohms from 20 to 20,000 Hz with no more than 0.04% total harmonic distortion.
POWER BANDWIDTH (IHF)		5 Hz to 40 kHz/8 ohms (Total harmonic distortion 0.04%)
SIGNAL-TO-NOISE RATIO (IHF)	PHONO	Better than 75 dB
	AUX	Better than 90 dB
RESIDUAL NOISE		Less than 0.6 mV at 8 ohms
CHANNEL SEPARATION (IHF)	PHONO	Better than 50 dB at 1,000 Hz
	AUX	Better than 55 dB at 1,000 Hz
DAMPING FACTOR		More than 40 (1 kHz, 8 ohms)
OUTPUT	SPEAKERS	A, B (4 to 16 ohms)/A+B (8 to 16 ohms)
	HEADPHONE	4 to 16 ohms
INPUT SENSITIVITY IMPEDANCE	PHONO	2.5 mV/47 kohms
	AUX	150 mV/47 kohms
	TUNER	150 mV/47 kohms
	TAPE	PIN: 150 mV/47 kohms
OUTPUT LEVEL	TAPE REC	PIN: 150 mV/3 kohms
FREQUENCY RESPONSE	PHONO	30 Hz to 15 kHz, +1 dB, -1 dB (RIAA)
	AUX	5 Hz to 60 kHz, +1 dB, -2 dB
TONE CONTROL	BASS	±10 dB at 100 Hz
	TREBLE	±10 dB at 10 kHz
LOUDNESS CONTROL		+10 dB at 100 Hz, +6 dB at 10 kHz
FILTER	HIGH	-3 dB at 5 kHz
	LOW	-3 dB at 100 Hz

FM TUNER SECTION

FREQUENCY RANGE		88 MHz to 108 MHz
SENSITIVITY (IHF)		1.7 μ V
CAPTURE RATIO		More than 1.3 dB
SELECTIVITY (IHF)		More than 70 dB
IMAGE REJECTION		More than 70 dB
IF REJECTION		More than 100 dB
SPURIOUS REJECTION		More than 80 dB
AM SUPPRESSION		50 dB
SIGNAL-TO-NOISE RATIO		75 dB
HARMONIC DISTORTION	MONO	Less than 0.15% (100% modulation)
	STEREO	Less than 0.3% (100% modulation)
MUTING		Switchable to ON-OFF
STEREO SEPARATION		More than 42 dB (1 kHz)
PILOT SIGNAL SUPPRESSION		More than 50 dB
SUB CARRIER SUPPRESSION		More than 50 dB
ANTENNA INPUT IMPEDANCE		300 ohms balanced, 75 ohms unbalanced

AM TUNER SECTION

FREQUENCY RANGE		525 kHz to 1,605 kHz
SENSITIVITY (IHF)		300 μ V/m (Bar Antenna), 20 μ V (External Antenna)
SELECTIVITY (IHF)		More than 30 dB
IMAGE REJECTION		More than 55 dB
IF REJECTION		More than 40 dB
ANTENNA		Built in ferrite bar antenna
SIGNAL-TO-NOISE RATIO		More than 40 dB
POWER REQUIREMENTS		120 V, 50 Hz
DIMENSIONS		480 (W) x 150 (H) x 360 (D) mm (18.9 x 5.9 x 14.1 inches)
WEIGHT		11 kg (24.2 lbs)

* For improvement purposes, specifications and design are subject to change without notice.

2. MODEL AA-R50

RATED POWER OUTPUT		2-CHANNEL DRIVEN	62 watts per channel, minimum RMS, at 8 ohms from 20 to 20,000 Hz with no more than 0.04% total harmonic distortion.
POWER BANDWIDTH (IHF)			
SIGNAL-TO-NOISE RATIO (IHF)		PHONO	Better than 75 dB
		AUX	Better than 90 dB
RESIDUAL NOISE		Less than 0.5 mV at 8 ohms	
CHANNEL SEPARATION (IHF)		PHONO	Better than 50 dB at 1,000 Hz
		AUX	Better than 55 dB at 1,000 Hz
DAMPING FACTOR		More than 40 (1 kHz, 8 ohms)	
OUTPUT		SPEAKERS	A, B (4 to 16 ohms)/A+B (8 to 16 ohms)
		HEADPHONE	4 to 16 ohms
INPUT SENSITIVITY/IMPEDANCE		PHONO	2.5 mV/47 kohms
		AUX	150 mV/47 kohms
		TUNER	150 mV/47 kohms
		TAPE	PIN: 150 mV/47 kohms
OUTPUT LEVEL		TAPE REC	PIN: 150 mV/3 kohms
FREQUENCY RESPONSE		PHONO	30 Hz to 15 kHz, +1 dB, -1 dB (RIAA)
		AUX	5 Hz to 70 kHz, +1 dB, -2 dB
TONE CONTROL		BASS	±10 dB at 100 Hz
		MID	±6 dB at 1 kHz
		TREBLE	±10 dB at 10 kHz
LOUDNESS CONTROL		+10 dB at 100 Hz, +6 dB at 10 kHz	
FILTER		HIGH	-3 dB at 5 kHz
		LOW	-3 dB at 100 Hz

FM TUNER SECTION

FREQUENCY RANGE	88 MHz to 108 MHz
SENSITIVITY (IHF)	1.8 μ V
CAPTURE RATIO	More than 1.3 dB
SELECTIVITY (IHF)	More than 70 dB
IMAGE REJECTION	More than 70 dB
IF REJECTION	More than 100 dB
SPURIOUS REJECTION	More than 80 dB
AM SUPPRESSION	50 dB
SIGNAL-TO-NOISE RATIO	70 dB
HARMONIC DISTORTION	MONO Less than 0.13% (100% modulation)
	STEREO Less than 0.25% (100% modulation)
MUTING	Switchable to ON-OFF
STEREO SEPARATION	More than 43 dB (1 kHz)
PILOT SIGNAL SUPPRESSION	More than 55 dB
SUB CARRIER SUPPRESSION	More than 55 dB
ANTENNA INPUT IMPEDANCE	300 ohms balanced, 75 ohms unbalanced

AM TUNER SECTION

FREQUENCY RANGE	525 kHz to 1,605 kHz
SENSITIVITY (IHF)	300 μ V/m (Bar Antenna) 20 μ V (External Antenna)
SELECTIVITY (IHF)	More than 30 dB
IMAGE REJECTION	More than 55 dB
IF REJECTION	More than 40 dB
ANTENNA	Built in ferrite bar antenna
SIGNAL-TO-NOISE RATIO	More than 40 dB
POWER REQUIREMENTS	120 V, 50 Hz
DIMENSIONS	480 (W) x 150 (H) x 360 (D) mm (18.9 x 5.9 x 14.1 inches)
WEIGHT	11.5 kg (25.3 lbs)

* For improvement purposes, specifications and design are subject to change without notice.

II. DISMANTLING OF UNIT

In case of trouble, etc. necessitating dismantling, please dismantle in the order shown in the photographs, Reassemble in reverse order.

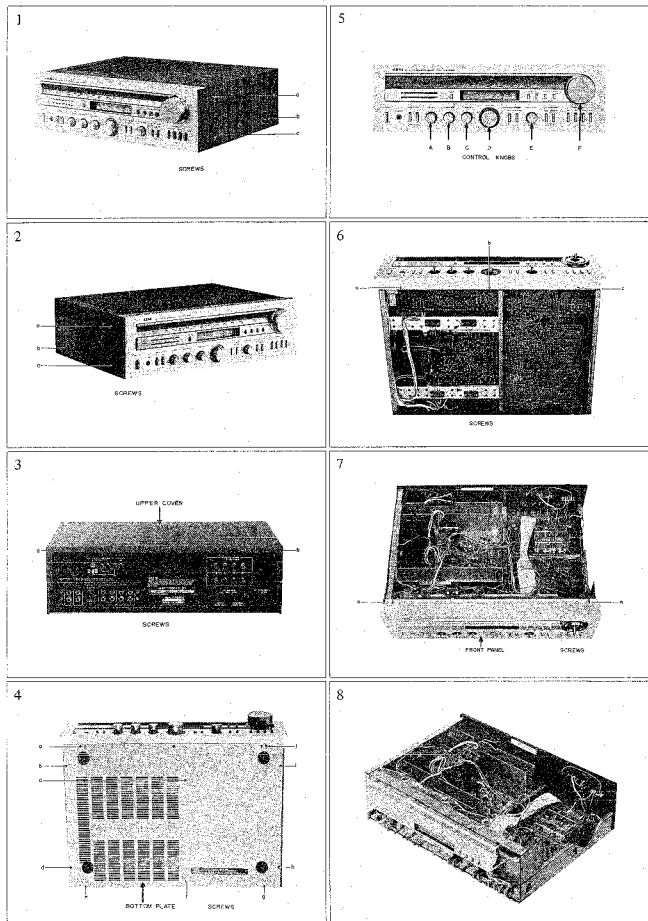

III. CONTROLS

I. MODEL AA-R40

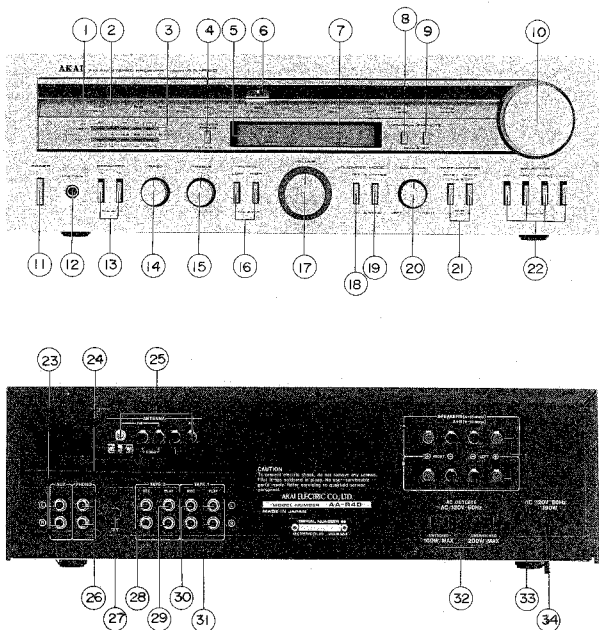

Fig. 1 Controls

- | | |
|---|--------------------------------------|
| 1. AM DIAL SCALE | 18. LOUDNESS SWITCH |
| 2. FM DIAL SCALE | 19. MODE SELECTOR |
| 3. LEFT AND RIGHT CHANNEL OUTPUT POWER INDICATORS | 20. STEREO BALANCE CONTROL |
| 4. RANGE SWITCH | 21. TAPE MONITOR SWITCHES |
| 5. SIGNAL STRENGTH METER | 22. SOURCE SELECTOR |
| 6. DIAL SCALE NEEDLE/FM STEREO INDICATOR | 23. AUX TERMINALS |
| 7. FM TUNING METER | 24. AM FERRITE BAR ANTENNA |
| 8. FM 25 μ SECS SWITCH | 25. FM AND AM ANTENNA TERMINAL |
| 9. FM MUTE SWITCH | 26. PHONO JACKS |
| 10. TUNING KNOB | 27. GROUND TERMINAL |
| 11. POWER SWITCH | 28. TAPE 2 SYSTEM REC JACKS |
| 12. HEADPHONE LACK | 29. TAPE 2 SYSTEM PLAY JACKS |
| 13. SPEAKER SWITCHES | 30. TAPE 1 SYSTEM REC JACKS |
| 14. BASS CONTROL | 31. TAPE 1 SYSTEM |
| 15. TREBLE CONTROL | 32. AC OUTLETS |
| 16. FILTER BUTTONS | 33. A AND B SYSTEM SPEAKER TERMINALS |
| 17. VOLUME CONTROL | 34. AC CORD |

2. MODEL AA-R50

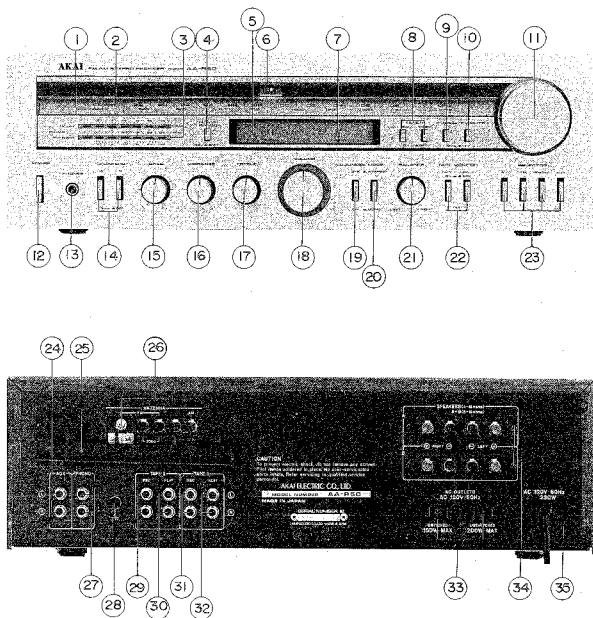

Fig. 2 Controls

- | | |
|---|--------------------------------------|
| 1. AM DIAL SCALE | 18. VOLUME CONTROL |
| 2. FM DIAL SCALE | 19. LOUDNESS SWITCH |
| 3. LEFT AND RIGHT CHANNEL OUTPUT POWER INDICATORS | 20. MODE SELECTOR |
| 4. RANGE SWITCH | 21. STEREO BALANCE CONTROL |
| 5. SIGNAL STRENGTH METER | 22. TAPE MONITOR SWITCHES |
| 6. DIAL SCALE NEEDLE/FM STEREO INDICATOR | 23. SOURCE SELECTOR |
| 7. FM TUNING METER | 24. AUX TERMINALS |
| 8. FILTER BUTTONS | 25. AM FERRITE BAR ANTENNA |
| 9. FM 25 μ SECS SWITCH | 26. FM AND AM ANTENNA TERMINALS |
| 10. FM MUTE SWITCH | 27. PHONO JACKS |
| 11. TUNING KNOB | 28. GROUND TERMINAL |
| 12. POWER SWITCH | 29. TAPE 2 SYSTEM REC JACKS |
| 13. HEADPHONE JACK | 30. TAPE 2 SYSTEM PLAY JACKS |
| 14. SPEAKER SWITCHES | 31. TAPE 1 SYSTEM REC JACKS |
| 15. BASS CONTROL | 32. TAPE 1 SYSTEM PLAY JACKS |
| 16. MID-RANGE CONTROL | 33. AC OUTLETS |
| 17. TREBLE CONTROL | 34. A AND B SYSTEM SPEAKER TERMINALS |
| | 35. AC CORD |

IV. PRINCIPAL PARTS LOCATION

I. MODEL AA-R40

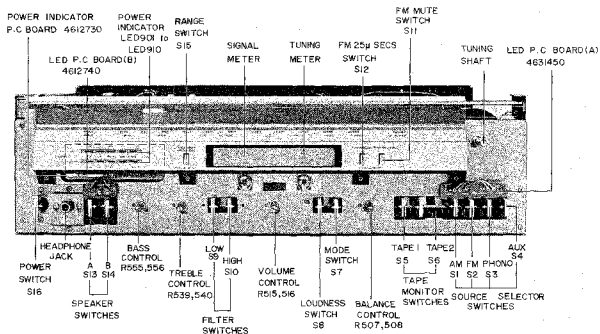

Fig. 3 Front View

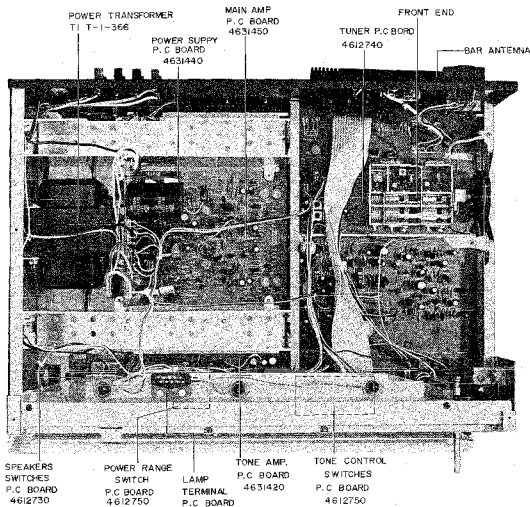

Fig. 4 Top View

2. MODEL AA-R50

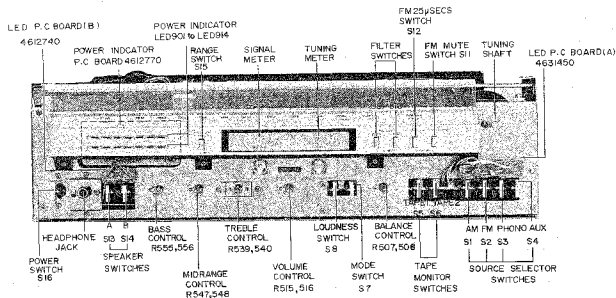

Fig. 5 Front View

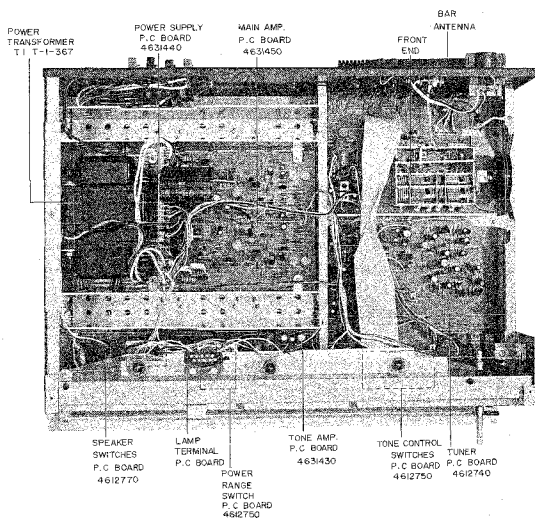

Fig. 6 Top View

V. BLOCK DIAGRAM

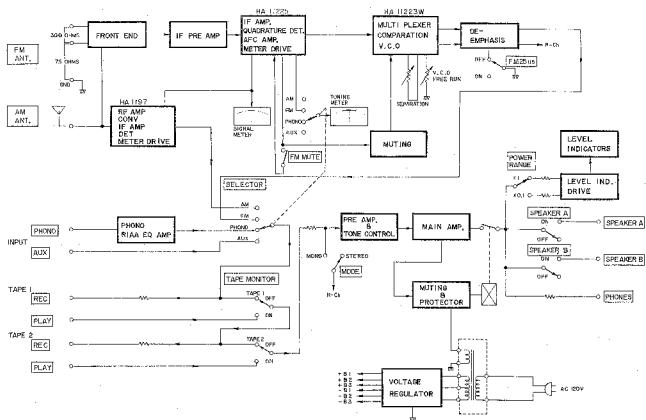

Fig. 7 Block Diagram

VI. LEVEL DIAGRAM

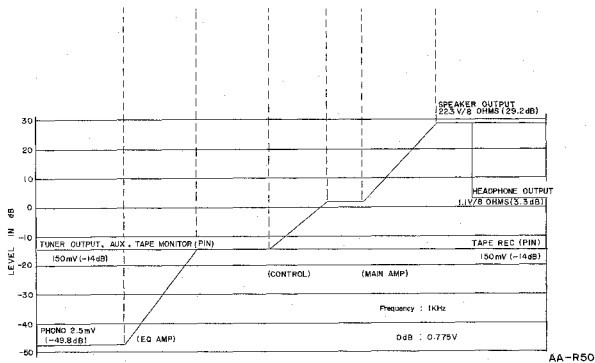
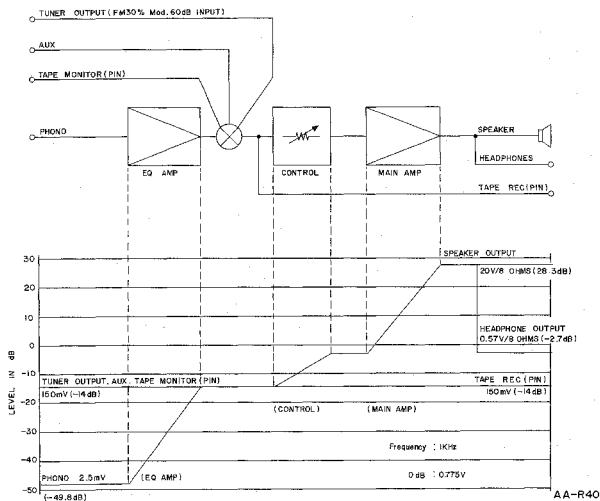

Fig. 8 Level Diagram

VII. AMPLIFIER ADJUSTMENT

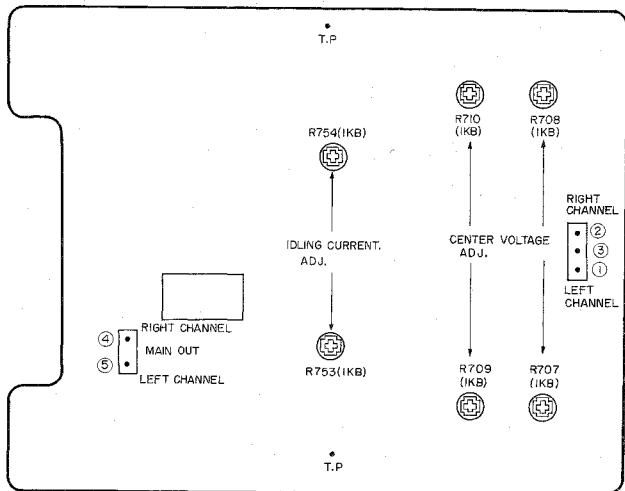

Fig. 9 Main Amp. P.C Board 4631450

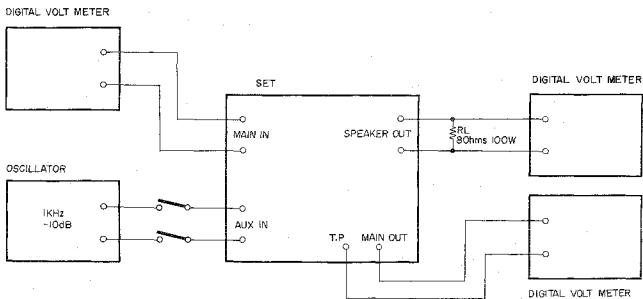

Fig. 10 Instrument Connections

1. CENTER VOLTAGE ADJUSTMENT (Refer to Figs. 9, 10)

- 1) Set the VOLUME control to the minimum position ("0") and LOW FILTER switch to OFF position.
- 2) Connect the digital volt meter to the MAIN IN (① - ③; left channel, ② - ③; right channel) inputs of Main Amp. P.C. Board.
- 3) Adjust the R707 (1 k Ω , left channel), R708 (1 k Ω , right channel), so that the digital volt meter reads 0 ± 1 mV.
- 4) Connect the digital volt meter to the SPEAKER output.
- 5) Adjust the R709 (22 k Ω , left channel), R710 (22 k Ω , right channel), so that the digital volt meter reads 0 ± 15 mV.

2. IDLING CURRENT ADJUSTMENT (Refer to Figs. 9, 10)

- 1) Connect the digital volt meter to the terminals between T.P. and Main Amp's output.
- 2) At non-signal input, adjust the R753 (1 kHz, left channel), R754 (1 kHz, right channel), so that the digital volt meter reads 7 to 15 mV.

NOTE: It takes about 5 minutes for the idling become stable.

3. POWER INDICATOR LED ADJUSTMENT (Refer to Figs. 10, 11)

- 1) Connect the O.S.C. to the AUX input.
- 2) Set the POWER RANGE switch to "x1" position, BALANCE control to mechanical center position.
- 3) Connect the resistor RL (8 ohms, 100 watts) to SPEAKER output.
- 4) Using the VOLUME, set to the rated output voltage. (AA-R40: 20.78 V, AA-R50: 22.63 V)
- 5) Turn the R905 (1 k Ω , left channel), R906 (1 k Ω , right channel) clockwise direction, so that all LEDs (AA-R40: 5 LEDs, AA-R50: 7 LEDs) become light up.

NOTE: Before adjustment, turn R905 and R906 fully counter clockwise direction.

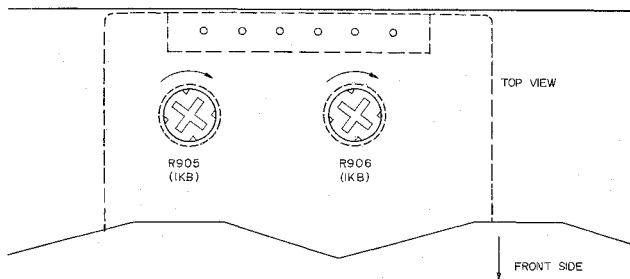

Fig. 11 Power Range Switch P.C Board 4612750

VIII. TUNER ADJUSTMENT

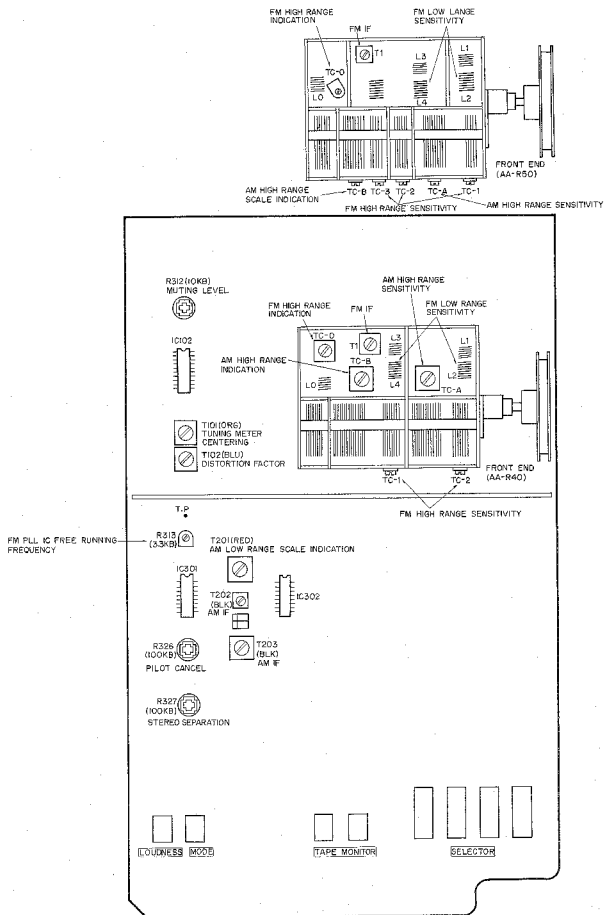

Fig. 12 Tuner P.C Board 4612740

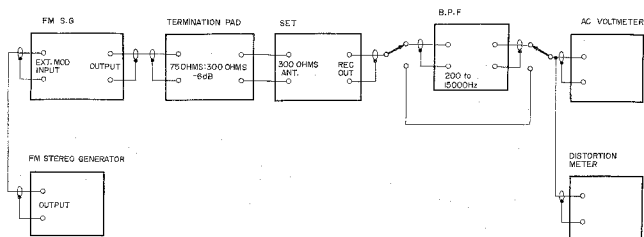

Fig. 13 Instrument Connections

1. FM ADJUSTMENT (Refer to Figs. 12, 13)

Step	Adjustment Item	Adjustment Point	Result	Remarks
1	Front End IF Coil	T1 (Front End)	Maximum Noise Level	SELECTOR to FM. Tune only noise without interference from broadcasting.
2	Tuning Meter Centering	T101 (ORG)	Centered Tuning Meter Indication	Same as above.
3	Distortion Factor	T102 (BLU)	Less than 0.3% Distortion Factor	98 MHz, 60 dB (mono) input. Less than 0.3% on both channels.
4	Confirmation of Tuning Meter Indication			If Tuning Meter Indication is not centered, re-adjust STEP 2 and 3 above.
5	High Range Scale Indication	TC-O (Front End)	Maximum Output	108 MHz, 60 dB (mono) input. TUNING INDICATOR to 108 MHz Error: Within ± 250 kHz
6	Confirmation of Low Range Scale Indication		Maximum Output	88 MHz, 60 dB (mono) input. TUNING INDICATOR to 88 MHz. Error: Within ± 250 kHz.
7	High Range Sensitivity	TC-1, TC-2 (AA-R40) TC-1 to TC-3 (AA-R50)	Less than 3% Distortion Factor	108 MHz, Less than 6 dB (mono) input. See NOTE 1, 2.
8	Low Range Sensitivity	L2, L4 (AA-R40) L2, L4, L5 (AA-R50)	Less than 3% Distortion Factor	88 MHz, Less than 6 dB (mono) input. See NOTE 1, 2.
9	Mute Level	R312 (10 kB)	No signal emitted from output	MUTE SW to ON 98 MHz, 30 dB (mono) input.
10	PLL IC Free Running Frequency	R313 (3.3 kB)	76 kHz	Frequency Counter to Test Point. See NOTE 3.
11	Stereo Indicator Lighting Confirmation			Stereo Indicator must be light.
12	Pilot cancel	R326 (100 kB)	Minimum output	Modulate FM SG only pilot signal. Disconnect the B.P.F.
13	Stereo Separation (Left→Right)	R327 (100 kB)	More than 40 dB	98 MHz, 60 dB (stereo), L ch input. Minimum output of R ch.
14	Stereo Separation (Right→Left)	R327 (100 kB)	More than 40 dB	98 MHz, 60 dB (stereo), R ch input. Maximum output of L ch.

Chart-1

- NOTES: 1. When the specified sensitivity of 6 dB cannot be obtained at the both frequency points 88 MHz and 108 MHz, repeat adjustment as in Step 7.
2. When the distortion factor of the sensitivity still does not comply shown on the result, adjust by turning the Front End FM IF coil core but not by more than 1/2 turn.
3. The free Running Frequency of the PLL IC must be exactly 76.00 kHz.

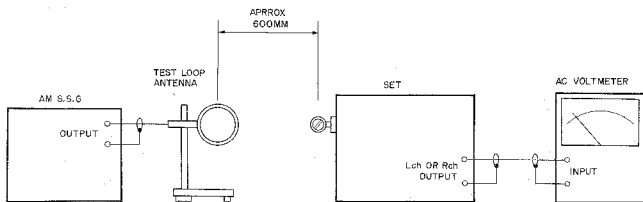

Fig. 14 Instrument Connections

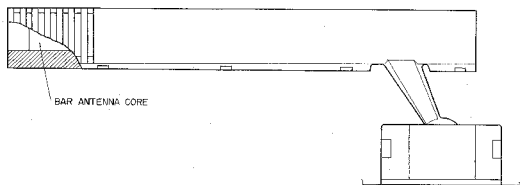

Fig. 15 Bar Antenna

2. AM ADJUSTMENT (Refer to Figs. 12, 14, 15)

Step	Adjustment Item	Adjustment Point	Result	Remarks
1	AM IF Coil	T202 (BLK) T203 (BLK)	Maximum Output	1,400 kHz, 50 dB input.
2	Low Range Scale Indication	T201 (RED)	Maximum Output	SELECTOR to AM 520 kHz, 50 dB input. TUNING INDICATOR to 520 kHz. Error: Within 2%
3	High Range Scale Indication	TC-B (Front End)	Maximum Output	1,650 kHz, 50 dB input. TUNING INDICATOR to 1,650 kHz. Error: Within 2%
4	Low Range Sensitivity	Bar Antenna core	Maximum Output Minimum Distortion Factor	600 kHz, 50 dB input. Distortion Factor: Less than 10%.
5	High Range Sensitivity	TC-A (Front End)	Maximum Output Minimum Distortion Factor	1,400 kHz, 50 dB input. Distortion Factor: Less than 10%.

Chart-2

NOTE: For the best result, repeat STEPs 1 through 5 two or three times.

IX. TUNING CORD THREADING

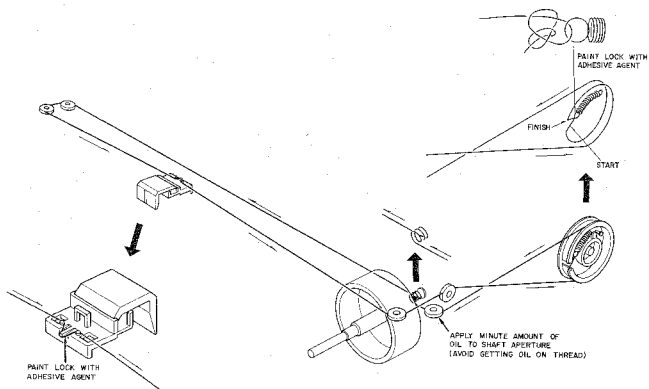

Fig. 16 Tuning Cord Threading

X. CLASSIFICATION OF VARIOUS P.C BOARDS

I. P.C BOARD TITLES AND IDENTIFICATION NUMBERS

P.C Board Title	P.C Board Number
Tone Amp. P.C Board	4631420 (AA-R40) 4631430 (AA-R50)
Power Supply P.C Board	4631440
Main Amp. P.C Board	4631450
LED P.C Board (A)	4631450
Power Indicator P.C Board	4612730 (AA-R40) 4631770 (AA-R50)
Speaker Switches P.C Board	4631730 (AA-R40) 4631770 (AA-R50)
Tuner P.C Board	4612740
LED P.C Board (B)	4612740
Tone Control Switches P.C Board	4612750
Power Range Switch P.C Board	4612750
Selector Switches P.C Board	4612750

Chart-3

2) Tone Amp. P.C Board 4631420 (AA-R40)

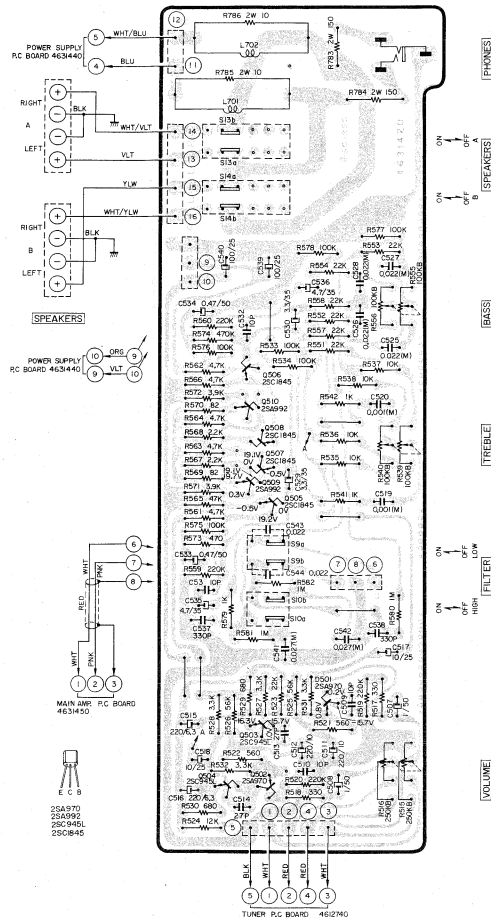

3) Tone Amp. P.C Board 4631430 (AA-R50)

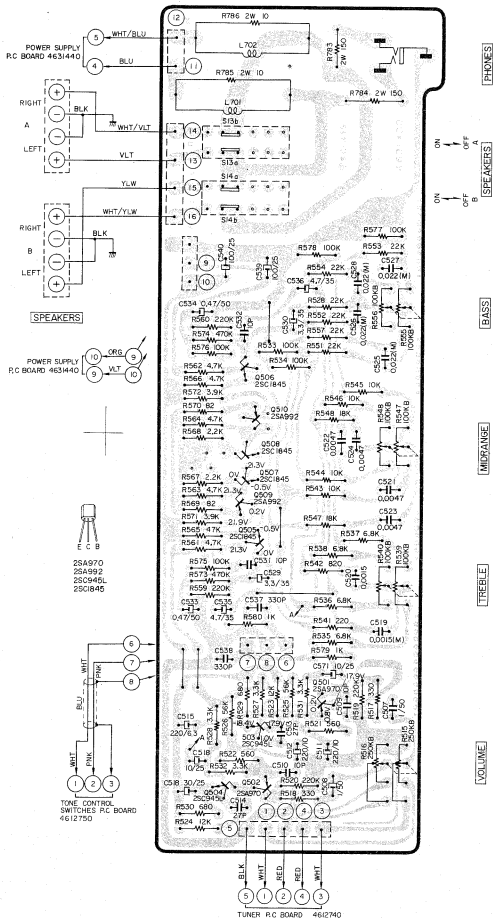

4) Main Amp. P.C Board 4631450

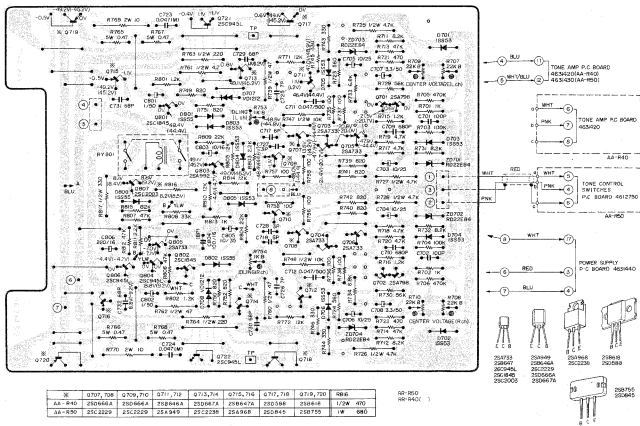

5) Power Supply P.C Board 4631440

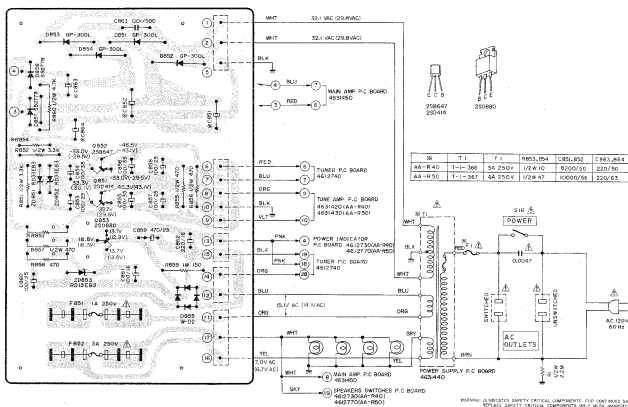

WARNING: INDICATES SAFETY CRITICAL COMPONENTS FOR CONTINUED SAFETY.
 *ALL SAFETY CRITICAL COMPONENTS SHOWN WITH MANUFACTURER'S
 INFORMATION DATA.
 **REPLACEMENT PARTS SHOULD BE PURCHASED IN QUANTITY FROM
 QUALIFIED SUPPLIER TO MAINTAIN THE QUALITY OF THE ORIGINAL PARTS.
 USE THE PARTS RECOMMENDED FOR THE PRODUCT.

6) Power Indicator P.C Board 4612730 (AA-R40)

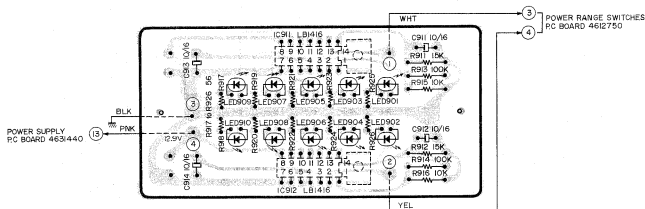

7) Power Indicator P.C Board 4612770 (AA-R50)

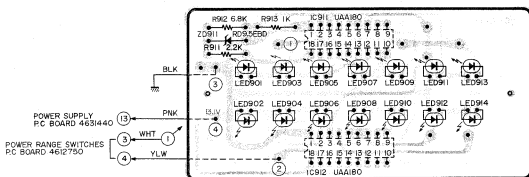

8) Power Range Switch P.C Board 4612750

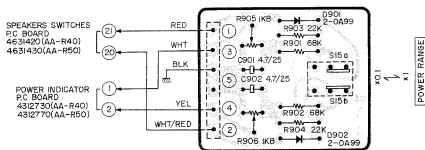

9) Speakers Switches P.C Board 4612730 (AA-R40)/4612740 (AA-R50) and LED P.C Board (B) 4612740

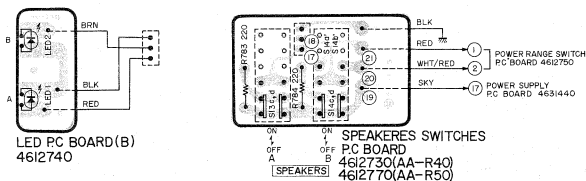

SECTION 2

PARTS LIST

TABLE OF CONTENTS

1. RECOMMENDED SPARE PARTS LIST	32
2. TUNER P.C BOARD BLOCK	34
3. MAIN AMP P.C BOARD BLOCK	34
4. TONE CONTROL P.C BOARD BLOCK	35
5. POWER SUPPLY P.C BOARD BLOCK	35
6. POWER RANGE P.C BOARD BLOCK	35
7. POWER INDICATOR P.C BOARD BLOCK	35
8. FINAL ASSEMBLY BLOCK	36
INDEX	38

Resistor and Capacitor which is not listed in this parts list, please refer to COMMON LIST FOR SERVICE PARTS.

HOW TO USE THIS PARTS LIST

1. This parts list is compiled by various individual blocks based on assembly process.
2. When ordering parts, please describe parts number, serial number, and model number in detail.
3. How to read list.

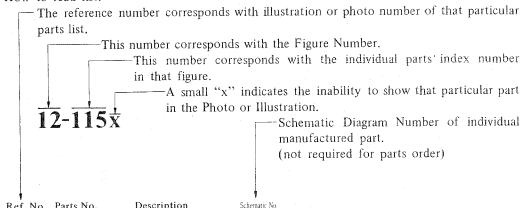

4. The symbol numbers shown on the P.C. Board list can be matched with the Composite Views of components of the Schematic Diagram or Service Manual.
5. The indications of Resistors and Capacitors in the photos of P.C. Board are being eliminated.
6. The shape of the parts and parts name, etc. can be confirmed by comparing them with the parts shown on the Electrical Parts Table of P.C. Board.
7. Both the kind of part and installation position can be determined by the Parts Number. To determine where a parts number is listed, utilize Parts Index at end of Parts List.
It is necessary first of all to find the Parts Number. This can be accomplished by using the Reference Number listed at right of parts number in the Parts Index. (meaning of ref. no. outlined in Item 3 above).
8. Utilize separate "Price List for Parts" to determine unit price. The most simple method of finding parts Price is to utilize the reference number.

CAUTION:

1. When placing an order for parts, be sure to list the parts no., model no., and description. There are instances in which if any of this information is omitted, parts cannot be shipped or the wrong parts will be delivered.
2. Please be careful not to make a mistake in the parts no. If the parts no. is in error, a part different from the one ordered may be delivered.
3. Because parts number and parts unit supply in the Preliminary Service Manual (Basic Parts List) may be partially changed, please use this parts list for all future reference.

WARNING: Δ INDICATES SAFETY CRITICAL COMPONENTS. FOR CONTINUED SAFETY, REPLACE SAFETY CRITICAL COMPONENTS ONLY WITH MANUFACTURER'S RECOMMENDED PARTS.

AVERTISSEMENT: Δ IL INDIQUE LES COMPOSANTS CRITIQUES DE SURETE. POUR MAINTENIR LE DEGRE DE SECURITE DE L'APPAREIL NE REMPLACER LES COMPOSANTS DONT LE FONCTIONNEMENT EST CRITIQUE POUR LA SECURITE QUE PAR DES PIECES RECOMMANDEES PAR LE FABRICANT.

AC INLET SYSTEM

This model is equipped with an AC INLET SYSTEM. Please refer to the AC INLET SYSTEM CHART below for the specific type. By the AC INLET SYSTEM, AC (mains) cord can be connected to and disconnected from the model because the model is provided with socket exclusively for AC (mains) cord on its main body.

Please note, however, that certain models are not equipped with this system and has a built-in AC (mains) cord as before.

AC INLET SYSTEM CHART

CLASS I

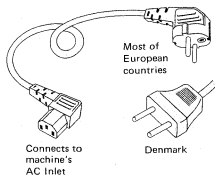
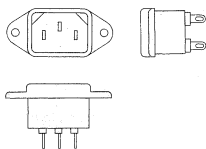

Most of European countries

Denmark

Connects to machine's AC Inlet



U.K.

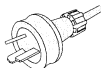

Australia differs according to wall socket

CLASS II

☐ This mark indicating double insulation will be attached to machine's rear panel

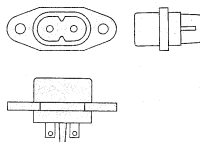

Picture 1
AC INLET
to be
installed
on machines

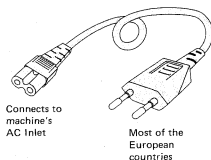

Connects to machine's AC Inlet

Most of the European countries



U.K.



Australia differs according to wall socket

Picture 2
AC (mains)
cord

Parts List for AC (mains) Cord Set

	Standard	Description	Type of AC Inlet	Parts No.
Class I	CEE	Cord Set CEE (3 cores)	3P	EW302993
	BEAB	Cord Set BEAB (3 cores)	3P	EW302994
	SAA	Cord Set SAA (3 cores)	3P	EW302996
	U/T	Cord Set U/T (3 cores)	3P	EW302646
Class II	CEE	Cord Set CEE (2 cores)	2P	EW638144
	BEAB	Cord Set BEAB (2 cores)	2P	EW302995
	SAA	Cord Set SAA (2 cores)	2P	EW302991
	U/T	Cord Set U/T (2 cores)	2P	EW302899

1. RECOMMENDED SPARE PARTS LIST

Because, if the parts listed below are on hand, almost any repair can be accomplished, we suggest that you stock these Recommended Spare Parts Items.

Parts No.	Description	Notes
BA704044	Main Amp PCB Comp. AA-R40	
BA704045	Main Amp PCB Comp. AA-R50	
BA704080	Power Supply PCB Comp. AA-R40	
BA704082	Power Supply PCB Comp. AA-R50	
BA704095	Tone Control PCB Comp. AA-R40	
BA704096	Tone Control PCB Comp. AA-R50	
BA704021	Tuner PCB Comp. AA-R40	
BA704022	Tuner PCB Comp. AA-R50	
BT704003	△ Power Trans. AA-R40	
BT704004	△ Power Trans. AA-R50	
ED704086	Diode GP 30D-L	
ED704089	Diode RD13EB3	
ED704060	Diode RD-22EB4	
ED704087	Diode RD-33EB3	
ED704104	Diode RD-7.5FB1	
ED704061	Diode VD-1212	
ED704088	Diode W02	
ED704062	Diode 1SS-55	
ED704108	Diode 2-0A99	
ED704000	LED PG5531KY	
ED704115	LED TLG-205	
ED302379	Silicon Diode 1SS53	
EE703864	AM Bar Ant AA-R20	
EE703845	Front End FF111U	(AA-R40)
EE704025	Front End FF611U	(AA-R50)
EF704083	△ Fuse 1A 250V U/L	
EF703830	△ Fuse 3A 250V U/L	
EF703906	△ Fuse 4A 250V U/L	
EF704019	△ Fuse 5A 250V U/L	
EI704030	IC HA11223W	
EI703843	IC HA11225	
EI299700	IC HA1197	
EI703907	IC LB1416	
EI704102	IC UAA180	
EI704026	IC μPC555H	
EL703807	Lamp 5V 75mA (WHT)	
EL703810	Lamp (Cord Type) 8V 0.3A L-190	
EL703812	Lamp (Cord Type) 8V 0.3A L-70	
EM703824	Meter AA-R20	
EP704075	Relay G2Z	
ER703891	Cement/R. 5W 0.47 ohms	

Parts No.	Description	Notes
ES704015	△ Push SW. SDV-1P TV-5 U/L	
ES704113	Push SW. AA-R40	
ES704106	Push SW. AA-R50	
ES704116	Push SW. SUF12	
ES704097	Push SW. SUF22	
ES704023	Push SW. SUF62	
ES703839	Push SW. (B) SUF22	
ES703839	Push SW. (B) SUF22	
ET704031	Transistor 2SA733	
ET703875	Transistor 2SA798	
ET704055	Transistor 2SA949	
ET704051	Transistor 2SA968	
ET704040	Transistor 2SA970 (GR)(BL)	
ET704041	Transistor 2SA992	
ET704049	Transistor 2SB618	
ET704056	Transistor 2SB646A	
ET704084	Transistor 2SB647	
ET704053	Transistor 2SB647A	
ET704047	Transistor 2SB775	
ET704042	Transistor 2SC1845	
ET704076	Transistor 2SC2003	
ET703881	Transistor 2SC2229	
ET704052	Transistor 2SC2238	
ET703854	Transistor 2SC945 (L)	
ET704400	Transistor 2SD414	
ET704050	Transistor 2SD588	
ET704058	Transistor 2SD666A	
ET704054	Transistor 2SD667A	
ET704048	Transistor 2SD845	
ET703894	Transistor 2SD880	
EV704098	Vol. GM70E 666C-100 kB	(Treble, Mid, Bass)
EV703841	Vol. GM70E 674C 250 kMN	(Balance)
EV703885	Vol. GM80E 775A-250kB	(Volume)

2. TUNER P.C BOARD BLOCK

Symbol No.	Parts No.	Description	Schematic No.
2-1	BA704021	Tuner PCB Comp. AA-R40	9460170
2-2	BA704022	Tuner PCB Comp. AA-R50	9460180
2-3	EE703845	Front End FF111U (AA-R40)	4910150
2-4	EE704025	Front End FF611U (AA-R50)	4910170
2-IC101	EI704026	IC μ PC555H	5180295
2-IC102	EI703843	IC HA11225	5180705
2-IC201	EI299700	IC HA1197	45-8-218
2-IC301	EI704030	IC HA11223W	518054S
2-Q301	ET703854	Transistor 2SC945 (L)	515077S
2-Q302	ET704031	Transistor 2SA733	514074S
2-Q303to305	ET703854	Transistor 2SC945 (L)	515077S
2-Q401,402	ET704040	Transistor 2SA970 (GR) (BL)	510103S
2-Q403,404	ET704042	Transistor 2SC1845	512115S
2-Q405,406	ET704041	Transistor 2SA992	510110S
2-D301to305	ED302379	Silicon Diode 1SS53	45-3-43
2-T101	EO703846	FM DET Coil (1) AA-R20	1240340
2-T102	EO703847	FM DET Coil (2) AA-R20	1240350
2-T201	EO703808	AM OSC Coil AA-R20	1230060
2-T202	EO703932	AM IFT Coil AA-R20	1230160
2-T203	EO703931	AM DET Coil AA-R20	1230110
2-L101to103	EO703849	Inductor RC-855 2.2 μ H (M)	1210660
2-L104	EO703848	Inductor 22 μ H	1210630
2-L301,302	EO704032	Inductor RX-9P-393K 39 μ H	1260120
2-CF101to103	ER704027	Ceramic Filter 10.70MHz (RED)	128058A
2-CF101to103	ER704028	Ceramic Filter 10.74MHz (WHT)	128058B
2-CF101to103	ER704029	Ceramic Filter 10.66MHz (BLK)	128058C
2-CF201	ER703863	Ceramic Filter SF2455A	1280310
2-R201	ER704038	Carbon/R. F 1/2W 150 ohms	329151L
2-R202	ER704039	Carbon/R. F 1/2W 47 ohms	329470L
2-R312	EV483388	Semi-Fixed/Vol. (Solid Type) SR19R 10kB	36-19-10
2-R313	EV704034	Semi-Fixed/Vol. RVG-10B 3.3kB	4300820
2-R326,327	EV704033	Semi-Fixed/Vol. SR19R 100kB	4301140
2-R337	ER704037	Carbon/R. F 1/2W 680 ohms	329681L
2-R340	ER704037	Carbon/R. F 1/2W 680 ohms	329681L
2-R419,420	ER704043	Carbon/R. F 1/2W 4.7k	329472L
2-R508	EV703841	Vol. GM70E 674C 250KMN (Balance)	4321010
2-C307	EC704036	Styrol/C. 1000pF(J) 50WV	223102V
2-C323,324	EC703861	Styrol/C. 470pF (J) 50WV	223471V
2-5	ES703839	Push SW. (B) SUF22 (Mode, Loudness)	4041240
2-6	ES704023	Push SW. SUF62 (Selector, Tape)	4041350
2-7	EJ703842	Pin Jack AA-R20	4444070
LED P.C BOARD (B) BLOCK			
2-8	ED704000	LED PG5531KY	5060170
2-9	ZW703815	Nylon Rivet 3x5.5	7408840
CUT P.C BOARD BLOCK			
2-10	ES704113	Push SW. AA-R40 (EM Mute)(AA-R40)	4041290
2-11	ES704106	Push SW. AA-R50 (Filter)(AA-R50)	4041390

3. MAIN AMP P.C BOARD BLOCK

Symbol No.	Parts No.	Description	Schematic No.
3-1	BA704044	Main Amp PCB Comp. AA-R40	9430930
3-2	BA704045	Main Amp PCB Comp. AA-R50	9430940
3-3	ZS666336	Tapping Screw #2 3x8 (Pan)	514086S
3-Q701,702	ET703875	Transistor 2SA798	514074S
3-Q703to706	ET704031	Transistor 2SA733	514074S
3-Q707to710	ET703881	Transistor 2SC2229 (AA-R50)	512108S
3-Q707to710	ET704058	Transistor 2SD666A (AA-R40)	511620S
3-Q711,712	ET704055	Transistor 2SA949 (AA-R50)	510112S
3-Q711,712	ET704056	Transistor 2SB646A (AA-R40)	511115S
3-Q713,714	ET704052	Transistor 2SC2238 (AA-R50)	512118S
3-Q713,714	ET704054	Transistor 2SD667A (AA-R40)	511022S
3-Q715,716	ET704051	Transistor 2SA958 (AA-R50)	510113S
3-Q715,716	ET704053	Transistor 2SB647A (AA-R40)	510046S
3-Q717,718	ET704048	Transistor 2SD845 (AA-R50)	513116S
3-Q717,718	ET704050	Transistor 2SD588 (AA-R40)	513109S
3-Q719,720	ET704047	Transistor 2SB775 (AA-R50)	511114S
3-Q719,720	ET704049	Transistor 2SB618 (AA-R40)	511109S
3-Q801,802	ET704042	Transistor 2SC1845	512115S
3-Q803	ET704041	Transistor 2SA992	510110S
3-Q804	ET703854	Transistor 2SC945 (L)	515077S
3-Q805	ET704031	Transistor 2SA733	514074S
3-Q806	ET703854	Transistor 2SC945 (L)	515077S
3-Q807	ET704076	Transistor 2SC2003	512114S
3-ZD701to704	ED704060	Diode RD-2E24B	502095S
3-D701to706	ED302379	Silicon Diode 1SS53	45-3-43
3-D707,708	ED704061	Diode VD-1212	505016S
3-D801,802	ED704062	Diode 1SS-55	501024S
3-D803to805	ED302379	Silicon Diode 1SS53	45-3-43
3-D806	ED704062	Diode 1SS-55	501024S
3-RY801	EP704075	Relay G2Z	1700300
3-R707to710	EV704063	Semi-Fixed/Vol. SR19R 22kB	4301170
3-R725to728	ER704043	Carbon/R. F 1/2W 4.7k	329472L
3-R747,748	ER704072	Carbon/R. F 1/2W 10k	329103L
3-R753,754	EV704064	Semi-Fixed/Vol. SR19R 1kB	4300720
3-R759to762	ER704039	Carbon/R. F 1/2W 47 ohms	329470L
3-R763,764	ER704073	Carbon/R. F 1/2W 220 ohms	329221L
3-R765to768	ER703891	Cement/R. SW 0.47 ohms	384479W
3-R769,770	ER704074	Metal Oxide Film/R. 2W 10 ohms	362100L
3-R801,802	ER704079	Carbon/R. F 1/2W 330 ohms (AA-R50)	329331L
3-R801,802	ER704078	Carbon/R. F 1/2W 1.2k (AA-R40)	329122L
3-R816,817	ER704078	Carbon/R. F 1/2W 1.2k (AA-R50)	329122L
3-R816,817	ER704079	Carbon/R. F 1/2W 330 ohms (AA-R40)	329331L
3-C711,712	EC704071	Mylar/C. 0.047 μ F 200WV	227473K
3-C713,714	EC704067	Ceramic/C. 6pF 500WV	234609D
3-C717,718	EC704066	Ceramic/C. 7pF 500WV	234709D
3-C723,724	EC704071	Mylar/C. 0.047 μ F 200WV	227473K
3-C727,728	EC704069	Ceramic/C. 3pF 500WV	234305D
3-C729to732	EC704065	Ceramic/C. 68pF 500WV	234680K

When ordering parts, please quote Parts Number, Description and Model Number.

Symbol No.	Parts No.	Description	Schematic No.
3-C804	EC704077	NP/C. 100 μ F 16WV	215230N
3-4	ZS421806	Screw, pan 3x8	
LED P.C BOARD (A) BLOCK			
3-5	ED704000	LED PG5531KY	5060170
3-6	ZW703815	Nylon Rivet 3x5.5	7400640

4. TONE CONTROL P.C BOARD BLOCK

Symbol No.	Parts No.	Description	Schematic No.
4-1	BA704095	Tone Control PCB Comp. AA-R40	9441550
4-2	BA704096	Tone Control PCB Comp. AA-R50	9441560
4-Q501,502	ET704040	Transistor 2SA970 (GR)(BL)	510103S
4-Q503,504	ET703854	Transistor 2SC945 (L)	515007S
4-Q505to508	ET704042	Transistor 2SC1845	512115S
4-Q509,510	ET704041	Transistor 2SA992	510110S
4-L701,702	EO704099	Choke Coil AA-R40	1210820
4-R515	EV703885	Vol. GM80E 775A-250kB (Volume)	4320990
4-R535	EV704098	Vol. GM70E 666C 100kB (Treble)	4321020
4-R547	EV704098	Vol. GM70E 666C 100kB (Mid)(AA-R50)	4321020
4-R555	EV704098	Vol. GM70E 666C 100kB (Bass)	4321020
4-R783,784	ER704101	Metal Oxide Film/R. 2W 150 ohms	362151B
4-R785,786	ER704100	Metal Oxide Film/R. 2W 10 ohms	362100B
4-3	ES704097	Push SW. SUF22 (Speaker)	4041340
4-4	ES703839	Push SW. (B) SUF22 (Filter)(AA-R40)	4041240
4-5	EJ703868	Headphone Jack AA-R20	4530260

5. POWER SUPPLY P.C BOARD BLOCK

Symbol No.	Parts No.	Description	Schematic No.
5-1	BA704080	Power Supply PCB Comp. AA-R40	9451030
5-2	BA704082	Power Supply PCB Comp. AA-R50	9451040
5-3	ZS666336	Tapping Screw #2 3x8 (Pan)	
5-Q851	ET704400	Transistor 2SD414	515074S
5-Q852	ET704084	Transistor 25B647	510045S
5-Q853	ET703894	Transistor 2SD880	513106S
5-D851to854	ED704086	Diode GP 30D-L	560063S
5-D855	ED704088	Diode W02	560061S
5-ZD851,852	ED704087	Diode RD-33EB3	502067S
5-ZD853	ED704089	Diode RD-13EB3	502063S
5-R851,852	ER704091	Carbon/R. F 1/2W 3.3k	329332L
5-R853,854	ER704094	Carbon/R. F 1/2W 100 ohms (AA-R50)	328101L
5-R853,854	ER704109	Carbon/R. F 1/2W 47 ohms (AA-R40)	328470L
5-R855to858	ER704093	Carbon/R. F 1/2W 470 ohms	329471L
5-R859	ER704038	Carbon/R. F 1/2W 150 ohms	329151L
5-C851,852	EC704110	Elect./C 10000 μ F 56WV (AA-R50)	2100070
5-C851,852	EC704090	Elect./C 8200 μ F 50WV (AA-R40)	2100080
5-F851	EF704083	Δ Fuse 1A 250V U/L	4700590
5-F852	EF703830	Δ Fuse 3A 250V U/L	4700630

6. POWER RANGE P.C BOARD BLOCK

Symbol No.	Parts No.	Description	Schematic No.
6-D901,902	ED704108	Diode 2-0A99	500014G
6-S15	ES704116	Push SW. SUF12 (Power Range)	4041260
6-R905,906	EV704107	Semi-Fixed/Vol. SR29R 10kB (AA-R50)	4301220
6-R905,906	EV703909	Semi-Fixed/Vol. SR29R 207 1kB (AA-R40)	4300620

7. POWER INDICATOR P.C BOARD BLOCK

Symbol No.	Parts No.	Description	Schematic No.
7-IC911,912	EI704102	IC UAA180 (AA-R50)	518066S
7-IC911,912	EI703907	IC LB1416 (AA-R40)	518075S
7-ZD911	ED704104	Diode RD-7.5FB1 (AA-R50)	502062S
7-LED901to914	ED704115	LED TLG-205	5060220

8. FINAL ASSEMBLY BLOCK

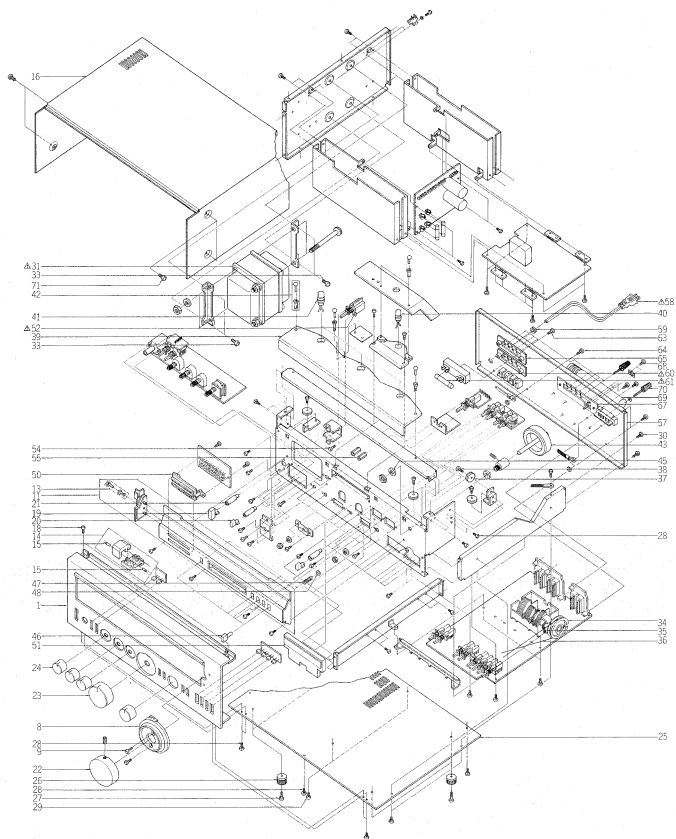

FINAL ASSEMBLY BLOCK

Ref. No.	Parts No.	Description	Schematic No.	Ref. No.	Parts No.	Description	Schematic No.
FRONT PANEL BLOCK				8-71	ZS537006	Screw, Bind 4x8 (Black)	
8-1	BD703994	Front Panel BLK AA-R50	7884700				
8-2x	BD703993	Front Panel BLK AA-R40	7884690				
8-3x	MS703786	Button Guide AA-R20	7401920				
8-4x	MS703788	Button Guide (2) AA-R20	7401940				
8-5x	MS703995	Button Guide LED-2 AA-R40	7401960				
8-6x	MS703996	Button Guide LED-4 AA-R40	7401950				
8-7x	ZW703997	Vol. Ring AA-R40	7401910				
8-8	ZW703998	Tuning Ring AA-R40	7402040				
8-9	ZS666336	Tapping Screw #2 3x8 (Pan)					
8-10x	TA703999	Panel Washer AA-R40	7401900				
8-11	TA704011	Dial Scale Assy AA-R50	7802530				
8-12x	TA704010	Dial Scale Assy AA-R40	7802520				
8-13	ZW703815	Nylon Rivet 3x5.5	7400840				
8-14	TA704007	Pointer Part AA-R40	7860580				
8-15	EL703807	Lamp 5V 75mA (WHT)	5805080				
8-16	BC704112	Upper Cover AA-R40	7821010				
8-17x	ZS609197	Tapping Screw #2 3x6					
Pan head							
8-18	ZS666336	Tapping Screw #2 3x8 (Pan)					
8-19	SB703794	Button (A) AA-R20	7852120				
8-20	SB703795	Button (B) AA-R20	7852110				
8-21	MS703796	Button Shaft AA-R20	7401890				
8-22	SK704059	Knob RSL-54 AA-R40	7841330				
8-23	SK703792	Knob RSL-33D AA-R20	7841340				
8-24	SK703793	Knob RSL-20D AA-R20	7841350				
8-25	SP704001	Bottom Plate AA-R40	7325860				
8-26	SA703922	Foot AA-R20	7402080				
8-27	ZS565942	Tapping Screw, #2 pan 4x8					
8-28	ZS609120	Tapping Screw, #2 3x6 (Pan)					
8-29	ZS666336	Tapping Screw, #2 3x8 (Pan)					
8-30	ZS609197	Tapping Screw, #2 3x6					
Pan head							
8-31	BT704004	△ Power Trans. AA-R50	1103670				
8-32x	BT704003	△ Power Trans. AA-R40	1103660				
8-33	ZS313796	S-Tight Screw, bind 4x6					
8-34	TA704005	Dial Drum D50 AA-R40	7401020				
8-35	ZG704006	Spring (J) AA-R40	7440290				
8-36	TA207347	Thread D05					
8-37	MR703805	Pulley D9=9 AA-R20	7400790				
8-38	MS703806	Pulley Shaft AA-R20	7121120				
8-39	TA704008	Illumination Plate AA-R40	7402020				
8-40	EL703810	Lamp (Cord Type) 8V 0.3A L-190	5808170				
8-41	EL703812	Lamp (Cord Type) 8V 0.3A					
L-70							
8-42	ZW703813	Nylon Rivet 3x8	5808180				
8-43	TA704009	Dial Wheel AA-R40	7401430				
8-44x	ZW272722	Toothed Lock Washer M9	7152460				
D9.3x13x0.5t							
8-45	ZW436026	Washer (SPC) D9.2x15x0.5t					
8-46	SB703817	Button (C) AA-R20	7852130				
8-47	ZG703818	Spring (V) AA-R20	7440400				
8-48	ZW703819	Button Stopper AA-R20	7401460				
8-49x	TA704012	Power Indicator AA-R40	7402050				
8-50	TA704014	Power Indicator AA-R50	7402060				
8-51	EM703824	Meter AA-R20	4582550				
8-52	ES704015	△ Push Sw. SDV-1P TV-5					
U/L							
8-53x	EC704016	△ Ceramic/C. 0.0047μF 125VAC	4041140				
8-54	ZS379350	Screw, pan 3x6					
8-55	ZS703823	Stud AA-R20	7121030				
8-56x	SP704017	Rear Panel AA-R40	7325790				
8-57	SP704018	Rear Panel AA-R50	7325800				
8-58	EW703828	△ AC Cord (BLK) AA-R20	606007A				
8-59	EZ703829	Strain Relief SR-3P-4	7400620				
8-60	EJ703831	△ AC Socket AA-R20	4500150				
8-62x	EF704019	△ Fuse 5A 250V U/L	4700540				
8-63	ZS609208	Tapping Screw #2 3x8 (Pan)					
8-64	ZS417407	Screw, pan head 3x10 (Black)					
8-65	EJ703832	AP Terminal AA-R20	4450470				
8-66x	ZS609208	Tapping Screw #2 3x8 (Pan)					
8-67	EJ704020	Ant Terminal AA-R40	4450520				
8-68	ZS355522	Screw, pan head 3x6 (Black)					
8-69	EE703864	AM Bar Ant AA-R20	1200410				
8-70	EJ306940	Earth Terminal	32-1-87				

When ordering parts, please quote Parts Number, Description and Model Number.

INDEX

Parts No.	Ref. No. & Symbol No.	Parts No.	Ref. No. & Symbol No.	Parts No.	Ref. No. & Symbol No.	Parts No.	Ref. No. & Symbol No.	Parts No.	Ref. No. & Symbol No.
BA704021	2-1	E1704026	2-IC101	ES703839	4-4	EV704098	4-R555	ZS703823	8-55
BA704022	2-2	E1704030	2-IC301	ES704015	8-52	EV704107	6-R905,906	ZW272722	8-44x
BA704044	3-1	E1704102	7-IC911,912	ES704023	2-6	EW703828	8-58	ZW436026	8-45
BA704045	3-2	EJ306940	8-70	ES704097	4-3	EZ703829	8-59	ZW703813	8-42
BA704080	5-1	EJ703831	8-60	ES704106	2-11	MR703805	8-37	ZW703815	2-9
BA704082	5-2	EJ703832	8-65	ES704113	2-10	MS703786	8-3x	ZW703815	3-6
BA704095	4-1	EJ703842	2-7	ES704116	6-515	MS703788	8-4x	ZW703815	8-13
BA704096	4-2	EJ703868	4-5	ET703854	2-Q301	MS703796	8-21	ZW703819	8-48
BC704112	8-16	EJ704020	8-67	ET703854	2-Q303to305	MS703806	8-38	ZW703997	8-7x
BD703993	8-2x	EL703807	8-15	ET703854	3-Q804	MS703995	8-5x	ZW703998	8-8
BD703994	8-1	EL703810	8-40	ET703854	3-Q806	MS703996	8-6x		
BT704003	8-32x	EL703812	8-41	ET703854	4-Q503,504	SA703922	8-26		
BT704004	8-31	EM703824	8-51	ET703875	3-Q701,702	SB703794	8-19		
EC703861	2-C323,324	EO703808	2-T201	ET703881	3-Q707to710	SB703795	8-20		
EC704016	8-53x	EO703846	2-T101	ET703881	5-Q853	SB703817	8-46		
EC704036	2-C307	EO703847	2-T102	ET704031	2-Q302	SK703792	8-23		
EC704065	3-C729to732	EO703848	2-L104	ET704031	3-Q703to706	SK703793	8-24		
EC704066	3-C717,718	EO703849	2-L101to103	ET704031	3-Q805	SK704059	8-22		
EC704067	3-C713,714	EO703931	2-T203	ET704040	2-Q401,402	SP704001	8-25		
EC704069	3-C727,728	EO703932	2-T202	ET704040	4-Q501,502	SP704017	8-56x		
EC704071	3-C711,712	EO704032	2-L301,302	ET704041	2-Q405,406	SP704018	8-57		
EC704071	3-C723,724	EO704099	4-L701,702	ET704041	3-Q803	TA207347	8-36		
EC704077	3-C804	EP704075	3-RY801	ET704041	4-Q509,510	TA703999	8-10x		
EC704090	5-C851,852	ER703863	2-CF201	ET704042	2-Q403,404	TA704005	8-34		
ED704110	5-C851,852	ER703891	3-R765to768	ET704042	3-Q801,802	TA704007	8-14		
ED302379	2-D301to305	ER704027	2-CF101to103	ET704042	4-Q505to508	TA704008	8-39		
ED302379	3-D701to706	ER704028	2-CF101to103	ET704047	3-Q719,720	TA704009	8-43		
ED302379	3-D803to805	ER704029	2-CF101to103	ET704048	3-Q717,718	TA704010	8-12x		
ED704000	2-8	ER704037	2-R337	ET704049	3-Q719,720	TA704011	8-11		
ED704000	3-5	ER704037	2-R340	ET704050	3-Q717,718	TA704012	8-49x		
ED704060	3-ZD701to704	ER704038	2-R201	ET704051	3-Q715,716	TA704014	8-50		
ED704061	3-D707,708	ER704038	5-R859	ET704052	3-Q713,714	ZG703818	8-47		
ED704062	3-D801,802	ER704039	2-R202	ET704053	3-Q715,716	ZG704006	8-35		
ED704062	3-D806	ER704039	3-R759to762	ET704054	3-Q713,714	ZS13796	8-33		
ED704086	5-D851to854	ER704043	2-R419,420	ET704055	3-Q711,712	ZS35522	8-68		
ED704087	5-ZD851,852	ER704043	3-R725to728	ET704056	3-Q711,712	ZS37950	8-54		
ED704088	5-D855	ER704072	3-R747,748	ET704058	3-Q707to710	ZS417407	8-64		
ED704089	5-ZD853	ER704073	3-R763,764	ET704076	3-Q807	ZS421806	3-4		
ED704104	7-ZD911	ER704074	3-R769,770	ET704084	5-Q852	ZS537006	8-71		
ED704108	6-D901,902	ER704078	3-R801,802	ET704400	5-Q851	ZS65942	8-27		
ED704115	7-LED901to914	ER704078	3-R816,817	EV483388	2-R312	ZS609120	8-28		
EE703845	2-3	ER704079	3-R801,802	EV703841	2-R508	ZS609197	8-17x		
EE703864	8-69	ER704079	3-R816,817	EV703885	4-R515	ZS609197	8-30		
EE704025	2-4	ER704091	5-R851,852	EV703909	6-R905,906	ZS609208	8-63		
EF703830	5-F852	ER704093	5-R855to858	EV704033	2-R326,327	ZS609208	8-66x		
EF704019	8-62x	ER704094	5-R853,854	EV704034	2-R313	ZS666336	3-3		
EF704083	5-F851	ER704100	4-R785,786	EV704063	3-R707to710	ZS666336	5-3		
EI299700	2-IC201	ER704101	4-R783,784	EV704064	3-R753,754	ZS666336	8-9		
EI703843	2-IC102	ER704109	5-R853,854	EV704098	4-R535	ZS666336	8-18		
EI703907	7-IC911,912	ES703839	2-5	EV704098	4-R547	ZS666336	8-29		

SECTION 3

SCHEMATIC DIAGRAM

1. SCHEMATIC DIAGRAM OF ICs
2. AA-R40/R50 NO. 1582216A SCHEMATIC DIAGRAM

HA1197

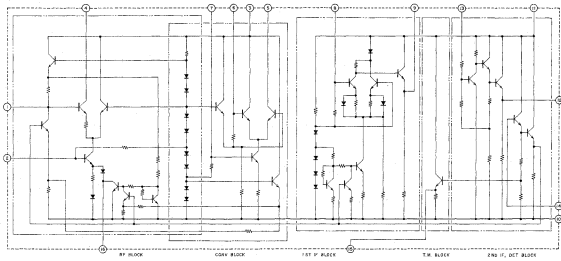

HA11223

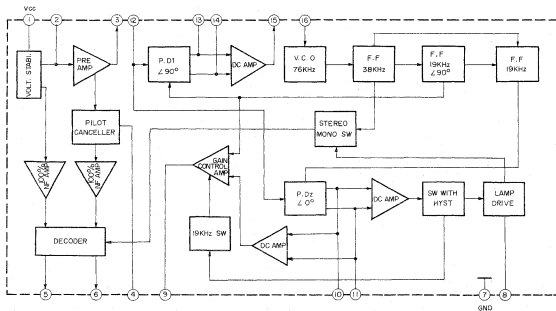

HA11225

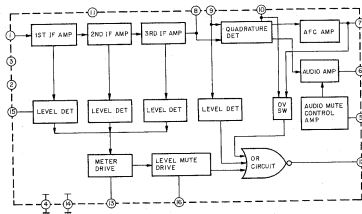

LB1416

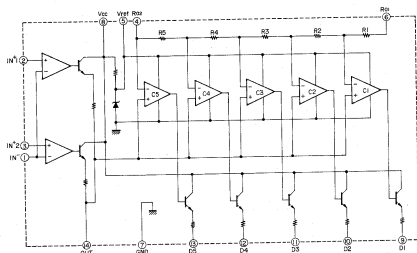

UA180

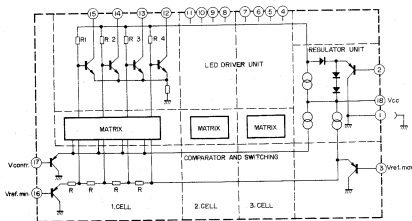

μPC555H

