

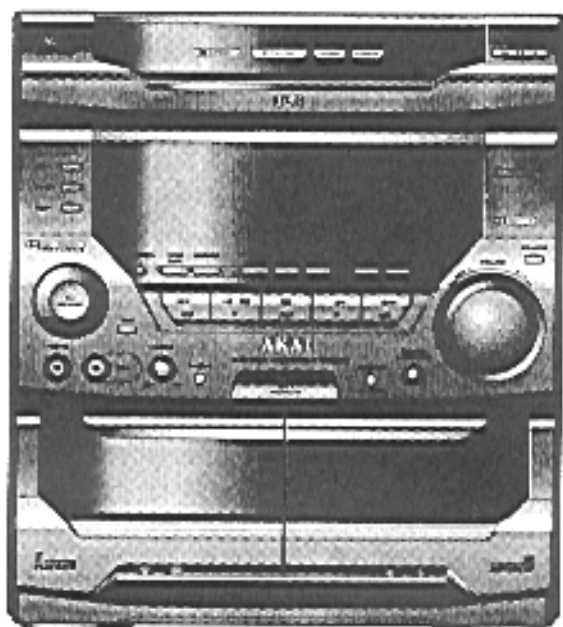

AKAI SERVICE MANUAL



- The above illustration shows the AC-620 model.

COMPACT
disc
DIGITAL AUDIO

 DOLBY B NR

 DOLBY SURROUND
PRO • LOGIC

MINI STEREO COMPONENT SYSTEM

MODEL **AC-420/423R/425K**

MODEL **AC-620/623R/625K**

MODEL **SR-425**

CONTENTS

SAFETY INSTRUCTIONS	2
INFORMATIONS	3
SPECIFICATIONS	4
CONTROLS	6
I. DISASSEMBLY	8
II. PRINCIPAL PARTS LOCATION.....	9
III. DISASSEMBLY OF MAIN COMPONENTS	11
IV. MECHANICAL ADJUSTMENT	16
V. ELECTRICAL ADJUSTMENT	17
VI. PARTS LIST	19
VII. ABBREVIATIONS	35

SAFETY INSTRUCTIONS

PRECAUTIONS DURING SERVICING

1. Parts identified by the \triangle (*) symbol parts are critical for safety. Replace them only with parts whose numbers are specified.
2. In addition to safety, other parts and assemblies are specified for conformance with such regulations as those applying to spurious radiation. These must also be replaced only with specified replacements.
Examples: RF converters, tuner units, antenna selection switches, RF cables, noise-blocking capacitors, noise-blocking filters, etc.
3. Use specified internal Wiring. Note especially:
 - 1) Wires covered with PVC tubing
 - 2) Double insulated wires
 - 3) High voltage leads
4. Use specified insulating materials for hazardous live parts. Note especially:
 - 1) Insulating Tape
 - 2) PVC tubing
 - 3) Spacers (insulating barriers)
 - 4) Insulating sheets for transistors
 - 5) Plastic screws for fixing micro switches
5. When replacing AC primary side components (transformers, power cords, noise blocking capacitor, etc.), wrap ends of wires securely about the terminals before soldering.



6. Make sure that wires do not contact heat generating parts (heat sinks, oxide metal film resistors, fusible resistors, etc.)
7. Check if replaced wires do not contact sharply edged or pointed parts.
8. Also check areas surrounding repaired parts.
9. Make sure that foreign objects (screws, solder droplets, etc.) do not remain inside the set.

MAKE YOUR CONTRIBUTION TO PROTECT THE ENVIRONMENT

Used batteries with the ISO symbol for recycling as well as small accumulators (rechargeable batteries), mini-batteries (cells) and starter batteries should not be thrown into the garbage can.



Please leave them at an appropriate depot.

SAFETY CHECK AFTER SERVICING

After servicing, make measurements of leakage-current or resistance in order to check if exposed parts are acceptably insulated from the supply circuit.

The leakage-current measurement should be done between accessible metal parts, (such as chassis, ground terminal, microphone jacks, signal input/output connectors, etc.) and the earth ground through a resistor of 1500 ohm paralleled with a 0.15 μ F capacitor, under the unit's normal working condition.

The leakage-current should be less the 0.5mA rms AC. The resistance measurement should be done between accessible exposed metal parts and power cord plug prongs with the power switch "ON" (if included). The resistance should be more than 2.2Mohms.

PRECAUTIONS IN REPAIRING

When repairing or adjusting the unit, please note the following points

1. Do not put excessive pressure on the mechanical part (operation part), including the pick-up block, as extremely high mechanical precision is required in these parts.
2. When the base is removed for repair or adjustment. Make sure that there are no metal objects between the P.C board or the mecha parts and the base.
3. The Micro-Computer and the CD signal processing ICs may be damaged by static electricity or leakage from a soldering iron during repairing. While soldering, please take the precautions against leakage as in the illustration.

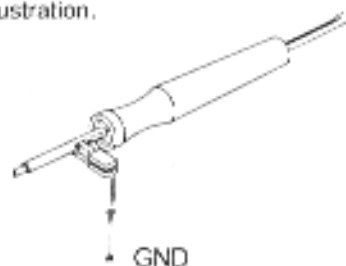

4. Do not loosen any screws in the pick-up block. Please refer to NOTE when replacing the pick up block.
5. To avoid hazardous invisible Laser Radiation, do not look at the Laser Beam (Objective lens) directly.
6. On model for some countries, laser warning labels are affixed on and inside of the unit as shown below. For your safety, read these labels carefully before repairing or adjusting the unit.

CAUTION

The use of controls or adjustments or the performance of procedures other than those specified herein may result in hazardous radiation.

[EUROPE, SCANDINAVIA, UK and AUSTRALIA]

CLASS 1 LASER PRODUCT
KLASSE 1 LASER PRODUKT
LUOKAN 1 LASER LAITE
KLASS 1 LASER APPARAT

Label affixed on the rear panel of the unit.

CAUTION: INVISIBLE LASER RADIATION WHEN OPEN.
ME: INTERLOCK DEFEATED AVOID EXPOSURE TO BEAM
ADVARSEL: USYNLIG LASERSTRÅLNING VED ÖP-
NING. SÄKERHETSÅFBRYDARE ER LÖSE ÅPPNINGEN
UNDGÅDDETTELSE FÖR STRÅLNING
VARNING: AVATTÄESSEN JA SUOJALUKITUS OHITET,
TÄESKÄ OLE* ALTTINA NÄKYVÄTÖMÄLLÄ LASERSTRÄ-
MÄLLE
ÄLÄ KÄYTSÄTSEESSEN
VARNING: ÖPNING LASERSTRÅLNING NÄR DENNA
DEL ÄR ÖPPNAD OCH SPÄRREN ÄR LÖSLÖSLAD *
BETRÄKTA EJ STRÅLEN

Label affixed on the CD MECHA BLOCK

INFORMATION

SYMBOLS FOR PRIMARY DESTINATION

Alphabet indicates the destination of the units as listed below.

Symbol	Principal Destination
[A]	USA
[B]	UK
[E]	Europe (except, UK)
[S]	Australia
[Y]	Germany
[U]	Universal
[Y*]	Custom version

VOLTAGE CONVERSION([U] [Y] Model only)

Before connecting the power cord, set the VOLTAGE SELECTOR located on the rear panel of the AC-425K/625K so that the correct voltage for your area is indicated.

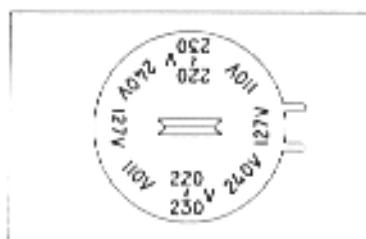

[U5,U8, Y6, Y7]

TEST MODE

Various kind of test modes are installed in this unit's microcomputer in order to test them on the production line. Following test modes among the various test modes can be used for adjustment, operation check or maintenance. To terminate the test mode, simply press the "POWER ON/STANDBY" button or disconnect the AC power cord from the AC outlet.

1. DECK TEST MODE

This test mode can be used for tape speed adjustment as well as bias oscillator frequency adjustment in TAPE DECK section.

While pressing and holding the "TAPE II" and "▶" (F) buttons, connect the AC power cord to AC outlet. The function turns to "TAPE I" and "DUBX1" as well as "T P I 0 0 0" indicators on the FLD light when this mode is engaged.

2. DECK CLEANING MODE

This test mode can be used for cleaning of the TAPE DECK mechanism.

Because, this mode enables engaging of the playback, fast forward (FF), and rewind (RWD) modes without a cassette tape, it makes the cleaning (such as the capstan shaft, magnetic head, pinch roller etc.) easier. While pressing and holding the "TAPE I" and "◀ II" (F) button, connect the AC power cord to the AC outlet. The tape run indicator light without the cassette tape when this mode is engaged.

SPECIFICATIONS

[Tuner Section]

Frequency range

FM	87.5-108MHz(50KHz step)
MW	530-1710KHz(U8) 531-1602KHz (except U8)
LW	144-288KHz(1KHz step) (E1/E2/E3/B1 only)
SW	3.8-12.5MHz(5KHz step) (Y7 only)

USABLE SENSITIVITY

FM	16.2dBf IHF,3%THD (except E1/E2/E3/B1) 20.2dBf IHF,3%THD (E1/E2/E3/B1)
MW	500uV/m
LW	800uV/m
SW	800uV/m

S/N Ratio(IHF)

FM	MONO 75dB. STEREO 65dB
MW	40dB
LW	30dB
SW	30dB
Stereo separation	40dB(at 1KHz)

[AMPLIFIER Section]

Power output	(AC-420/423R/425K) 50W+50W(6ohms, 10%THD, EIAJ) 40W+40W (6ohms, 1%THD, DIN) (AC-620/623R/625K) 30W+30W(6ohms, 10%THD, EIAJ) 25W+25W (6ohms, 1%THD, DIN)
--------------	--

Input sensitivity (AUX IN)..... 310mV/47K Ω

channel separation 70dB

Frequency response..... 10Hz-100KHz(-3dB)

[DECK SECTION]

Track system 4track, 2channel system

Frequency response 40Hz-15KHz (Normal tape, ± 3 dB)

40Hz-16KHz(Cro2 tape, ± 3 dB)

Wow & Flutter 0.09% (WRMS), 0.15%(DIN)

S/N ratio Dolby B 63dB (5KHz)

Dolby off 53dB (Cro2 tape)

Total harmonic distortion less than 0.5%(normal tape at 315Hz)

Channel separation 43dB

[CD SECTION]

Pick up system 3Beam Laser
 Sampling frequency 44.1KHz
 Error correction system Cross interleave read solomon
 Number of channels 2Channe
 Frequency response 20Hz-20KHz
 Wow & Flutter Below measurable limits

S/N ratio 83dB
 Total harmonic distortion 0.035% (at 1KHz)
 Channel separation 73dB(at 1KHz)
 Dynamic range 82dB (at 1KHz)

[GENERAL]

Power requirement AC 220-230V/50Hz
 E1/E2/E3/B1/S1 AC110/127/220-230/240V, 50/60Hz
 U5/U8/Y6/Y7 110W/AC-420/423R/425K, 130W/AC-620/623R/625K
 Weight 8.2Kg/AC-420/423R/425K, 8.2Kg/AC-620/623R/625K

[SPEAKER SECTION]

ITEM SR-425
 System Constructions 3-way 3-speakers
 Woofer Unit 135mm Cone type
 Midrange Unit 65mm Cone type
 Tweeter Unit 20mm dome type (piezo)
 System Impedance 6Ω
 Maxium Power Input 80w
 Sensitivity more than 87dB/w/m
 Frequency Response 60Hz-20KHz
 Harmonic Distortion less than 3%
 Enclosure Type bass reflex type
 Units Layout L/R mirror layout
 Dimension 200(W)X305(H)X265(D)
 Net Weight 3.6Kg/pc

For improvement purposes, specifications and design are subject to change without notice.
 Manufactured under license from Dolby Laboratories Licensing Corporation. "DOLBY" and the  symbol are trademarks of Dolby Laboratories Licensing Corporation.

CONTROLS

A MAIN UNIT

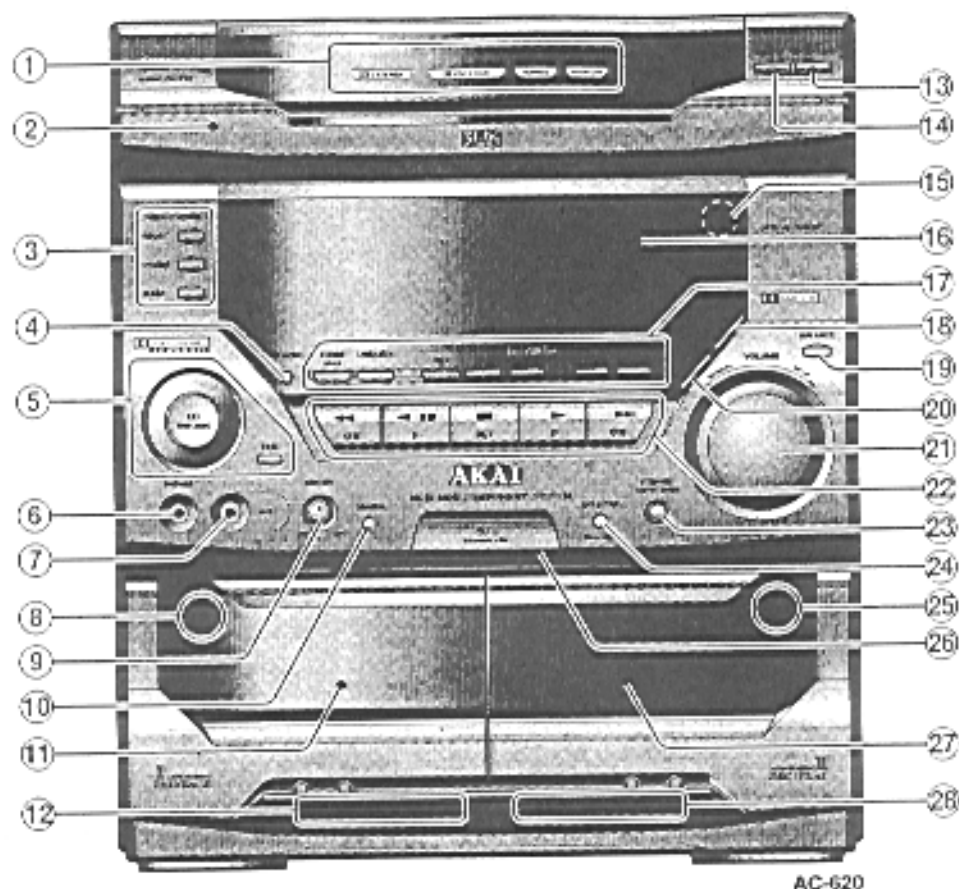

AC-620

- | | |
|---|---|
| <p>1. PRO LOGIC mode indicators (AC-620/623R/625K)</p> <ul style="list-style-type: none"> <input type="checkbox"/> 3 STEREO indicators <input type="checkbox"/> PRO LOGIC - NORMAL indicators <input type="checkbox"/> PRO LOGIC - PHANTOM indicators <p>2. Disc tray</p> <p>3. TIMER CONTROL buttons</p> <ul style="list-style-type: none"> PROG button ON/OFF button SLEEP button <p>4. CH MEMO button</p> <p>5. DOLBY PRO LOGIC operation buttons(AC-620/623R/625K only)</p> <ul style="list-style-type: none"> <input type="checkbox"/> PRO LOGIC on/off button TEST button <p>6. PHONES jack</p> <p>7. MIC jack</p> <p>8. Tape deck I PUSH OPEN button</p> <p>9. Mixing control</p> <p>10. Dimmer button</p> <p>11. Tape deck I cassette compartment</p> <p>12. Tape deck I direction indicator and transportation indicator</p> | <p>13. TRAY OPEN/CLOSE button</p> <p>14. DISC CHANGE button</p> <p>15. Remote sensor</p> <p>16. System FL display</p> <p>17. Input source select buttons(AUX is not included on the AC-420/423R/425K models)</p> <ul style="list-style-type: none"> TUNER BAND, LINE/AUX, CD1, CD2, CD3, TAPE I, TAPE II <p>18. DUB SPEEDx1/x2 button</p> <p>19. BALANCE button</p> <p>20. REC button</p> <p>21. Volume control</p> <p>22. Multi-function buttons</p> <p>23. DYNAMIC SUPER BASS button</p> <p>24. DOLBY NR button</p> <p>25. Tape deck II PUSH OPEN button</p> <p>26. STANDBY/ POWER ON button</p> <p>27. Tape deck II cassette compartment</p> <p>28. Tape deck II direction indicator and transportation indicator</p> |
|---|---|

B Remote Control

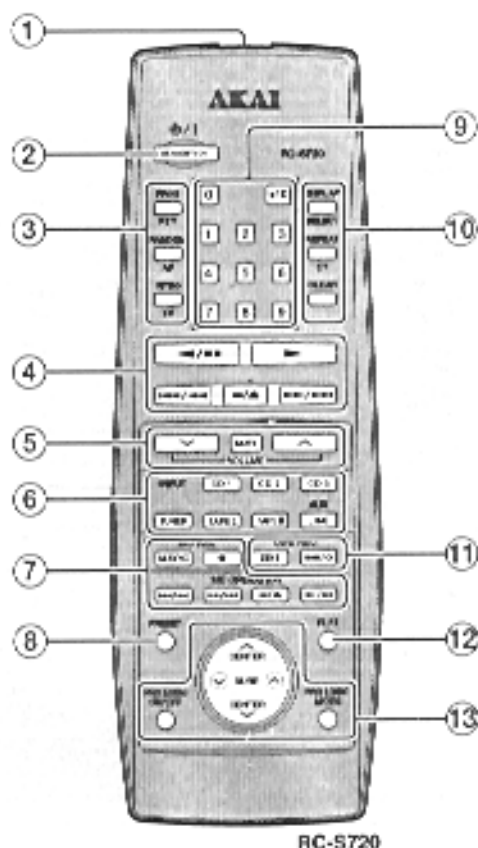

When using the remote control for operation, make sure that it is pointing to the remote sensor window on the main unit.

- | | |
|---|--|
| 1. Transmitting window | 8. PRESET button |
| 2. POWER ON/STANDBY button | 9. CD/TUNER 11 KEY buttons |
| 3. CD operation buttons/RDS buttons
(The RDS function is only available on the AC-423R/623R) | 10. CD operation buttons/RDS buttons
(The RDS function is only available on the AC-423R/623R) |
| 4. Multi-function buttons | 11. TAPE REC buttons |
| 5. VOLUME buttons | I/O REC/PAUSE button |
| 6. Input source select buttons | EDIT button |
| 7. MD operation buttons | 12. FLAT button |
| M-SYNC buttons | 13. PRO LOGIC operation buttons |
| ● REC button | PROG LOGIC ON/OFF buttons |
| ◀◀/▶▶ buttons | PROG LOGIC MODE button |
| ▶▶/▶▶▶ buttons | CENTER ^/~ buttons |
| ■/▲ buttons | SURROUND ^/~ buttons |
| ▶/ buttons | |

* These PROG LOGIC operation buttons are not included on the RC-S520 remote control (for AC-420/423R/425K model operation)

These MD operation buttons can only be used if you have connected the optional MD recorder (MD-720).

Note:

The remote control can not be used for some functions that require the combined pressing of two tape transportation buttons (intro scan or auto play for example). Please Use the Main unit's multi-function buttons for the operation of such functions.

II. PRINCIPAL PARTS LOCATION

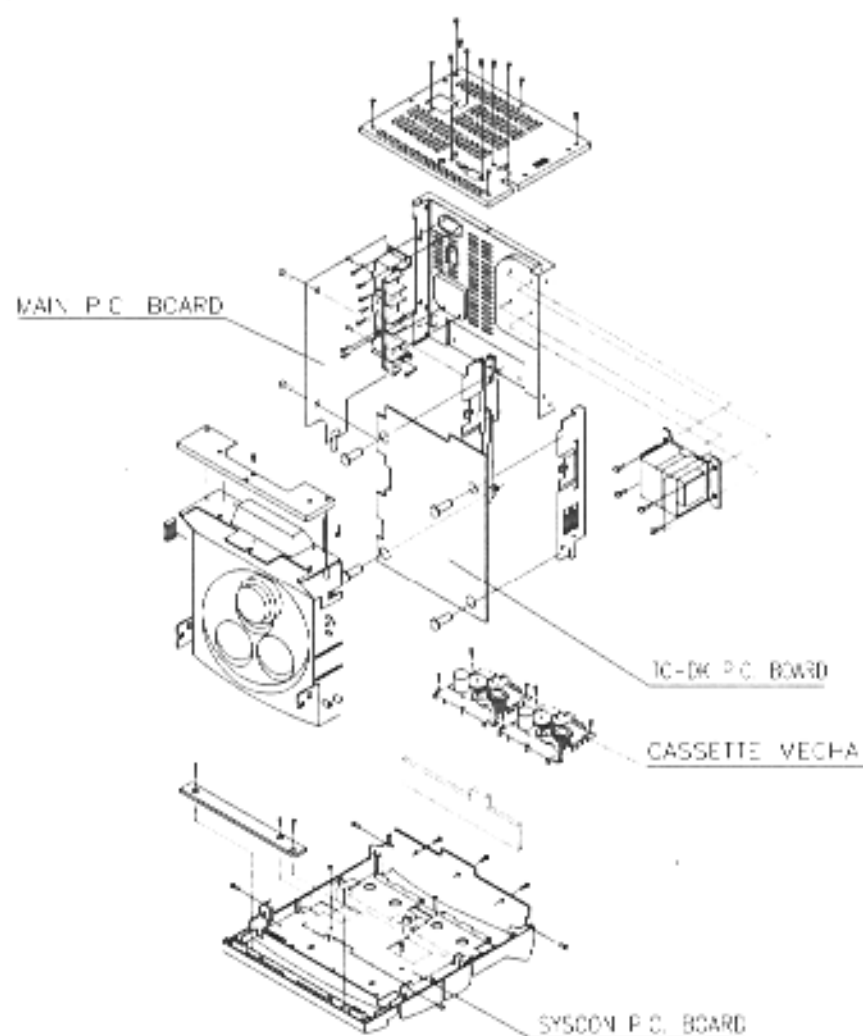

Fig. 2-1

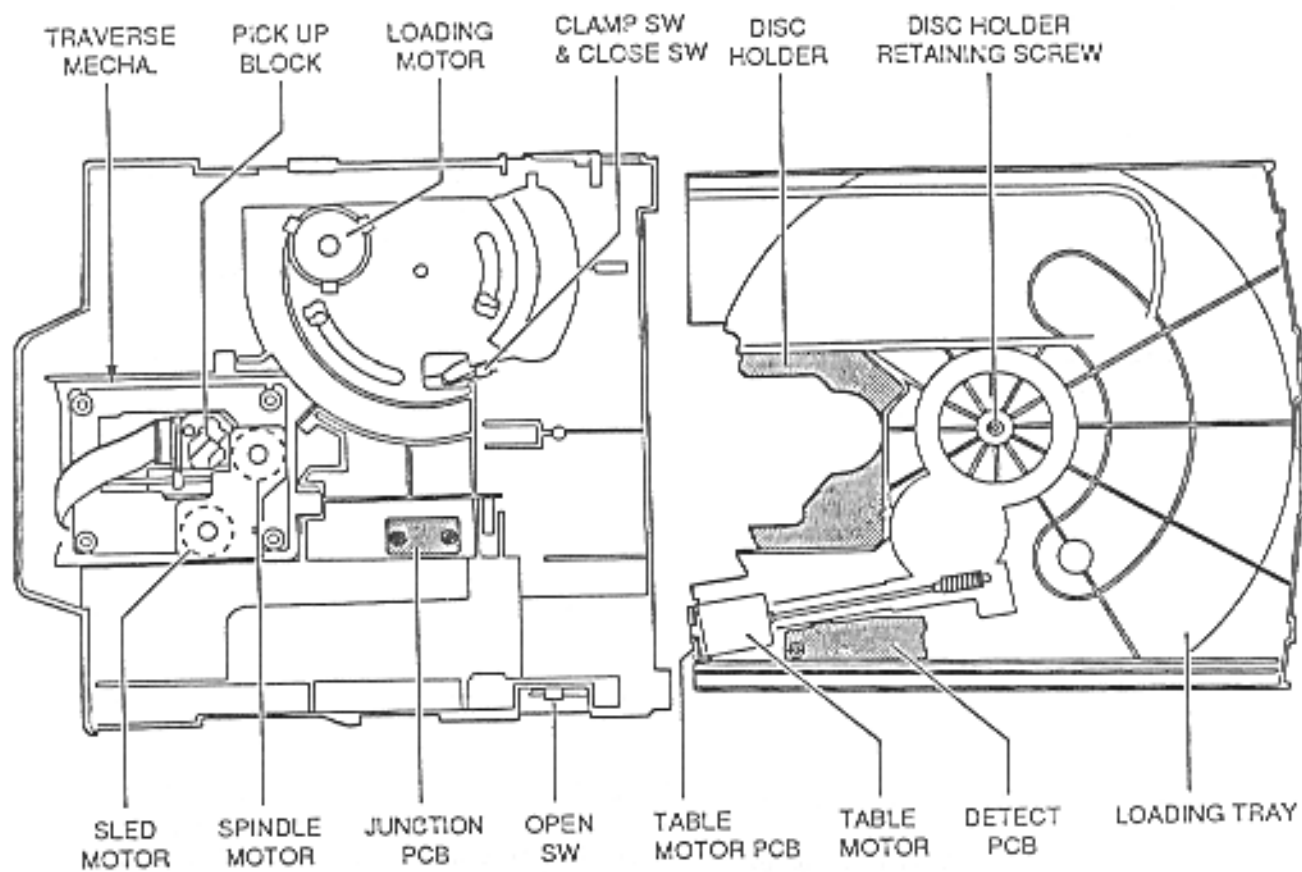

Fig. 2-2 CD PLAYER BLOCK

III. DISASSEMBLY OF THE MAIN COMPONENTS

3-1. CD PLAYER BLOCK

* Remove the CD PLAYER BLOCK before proceeding.

3-1-1. Removal of the TRAVERSE MECHA.

1) Remove the TRAVERSE COVER by releasing the two tabs in the direction of the arrow as shown in Fig. 3-1.

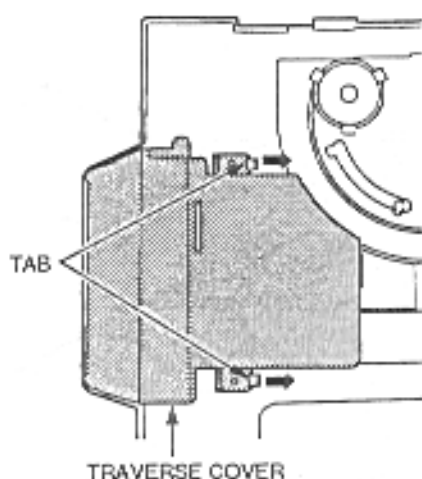

Fig. 3-1

2) Short the circuit on the PICK UP BLOCK with solder as shown in Fig. 3-2.

Note: To protect the laser diode from damage caused by high voltage static electricity, a part of the PCB on the PICK UP BLOCK has to be shorted before disconnecting the connectors. After replacement, be sure to connect the two connectors and then remove the solder of the shorted circuit before turning the power ON.

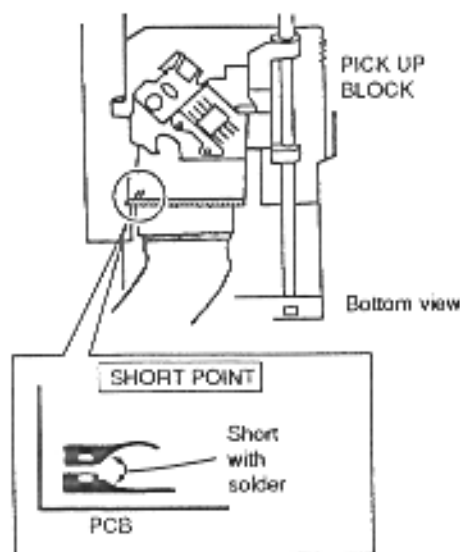

Fig. 3-2

3) Disconnect the two connectors carefully.

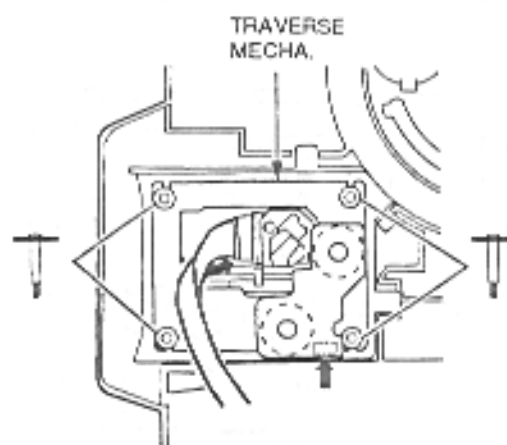

Fig. 3-3

4) Remove the four retaining screws, then remove the TRAVERSE MECHA.

5) Proceed in the reverse order for installation but never unsolder the shorted circuit before connecting the three connectors.

3-1-2. Replacement of the SLED MOTOR

1) Remove the TRAVERSE MECHA (refer to section 3-1-1).

2) Unsolder the leads of the SLED and SPINDLE MOTORS then remove the MOTOR PCB.

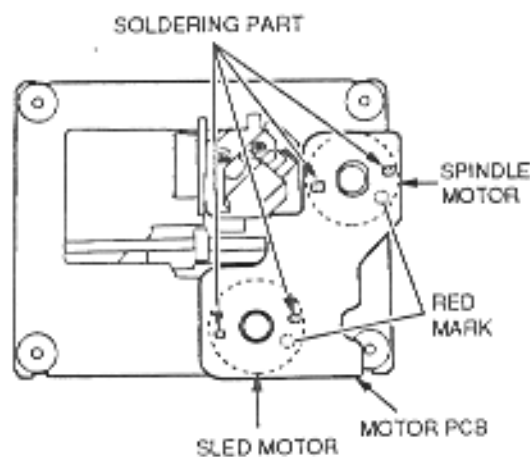

Fig. 3-4

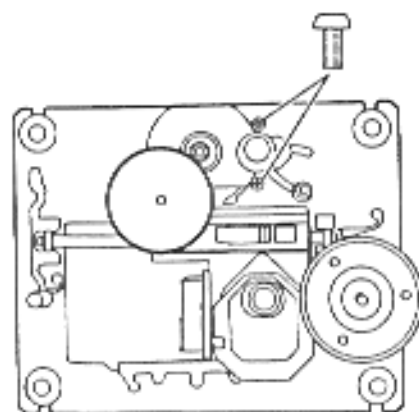

Fig. 3-5

3) Remove the two retaining screws, then remove the SLED MOTOR.

Next, extract the plastic gear from the motor shaft and attach it onto the new motor's shaft.

4) Reassemble in the reverse order.

About the SPINDLE MOTOR:

Replacement of the SPINDLE MOTOR itself is not recommended, because adjustment of the TURN TABLE height is quite critical and requires the use of a special jig.

3-1-3. Replacement of the PICK UP BLOCK

1) Remove the TRAVERSE MECHA (refer to section 3-1-1).

2) While pressing the (A) stopper upwards, pull the SLIDE SHAFT to the right to remove the PICK UP BLOCK, then replace the PICK UP BLOCK.

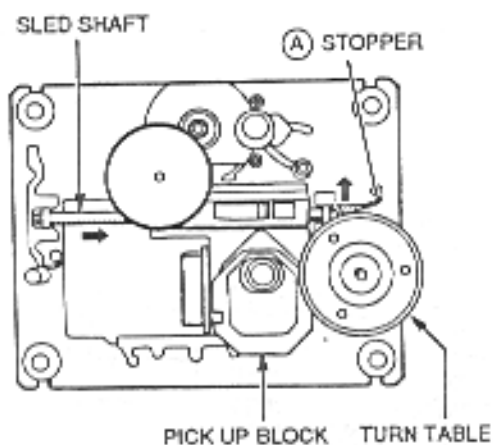

Fig. 3-6

3) Reassemble in the reverse order.

3-1-4. Replacement of the LOADING MOTOR

1) Slide the protruding part of the GEAR HOLDER PART in the direction of the arrow, then pull out the TRAY BLOCK.

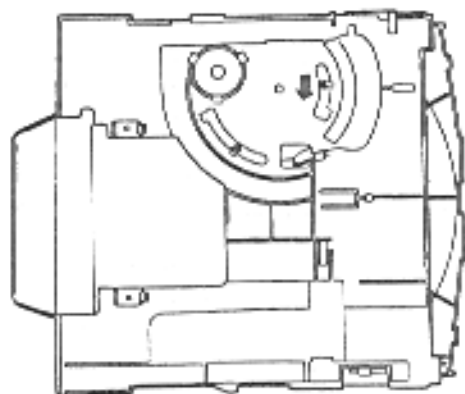

Fig. 3-7

2) Unhook the LOADING BELT with tweezers.

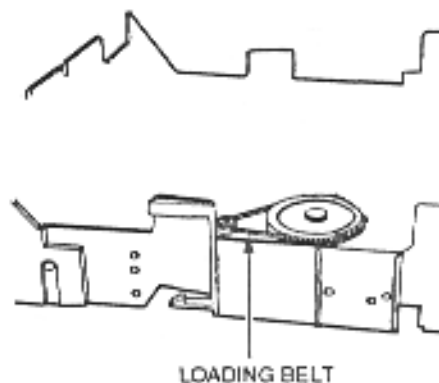

Fig. 3-8

3) Unsolder the lead wires of the LOADING MOTOR with a soldering iron.

4) While releasing the LOADING MOTOR's three retaining hooks, push the motor pulley part down with your middle finger to remove the LOADING MOTOR, then replace it.

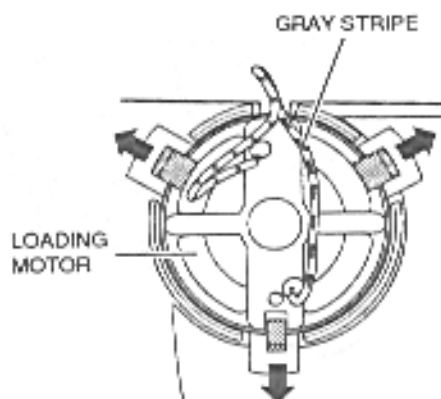

Fig. 3-9

5) Reassemble in the reverse order. Make sure that the wire with the gray stripe is connected to the motor's O marked terminal when soldering.

3-1-5. Removal of the TRAY BLOCK

1) If the TRAY BLOCK is in the "in" position, slide the protruding part of the GEAR HOLDER PART in the direction of the arrow and pull out the TRAY BLOCK slowly (refer to Fig. 3-7).

2) In order to disengage the two stoppers, carefully press the (B) part of the TRAY BLOCK downwards while pulling the TRAY BLOCK out as shown in Fig. 3-10.

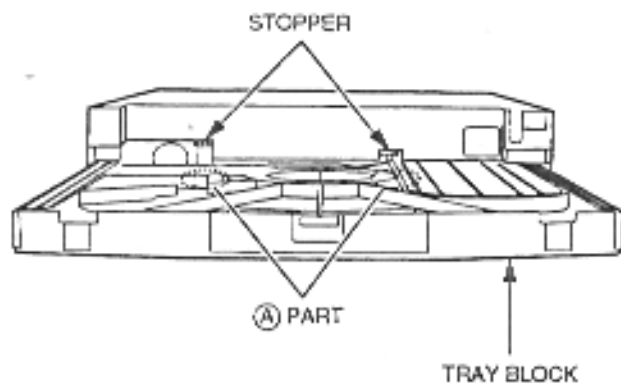

Fig. 3-10

- 4) Remove the TRAY BLOCK by pulling it out carefully.
- 5) Reassemble in the reverse order for installation. When reattaching the TRAY BLOCK to the chassis, carefully align the guides on both sides of the TRAY BLOCK with their corresponding rails on the chassis. Also, make sure that any one of the reference marks on the DISC HOLDER aligns with the reference mark on the LOADING TRAY.

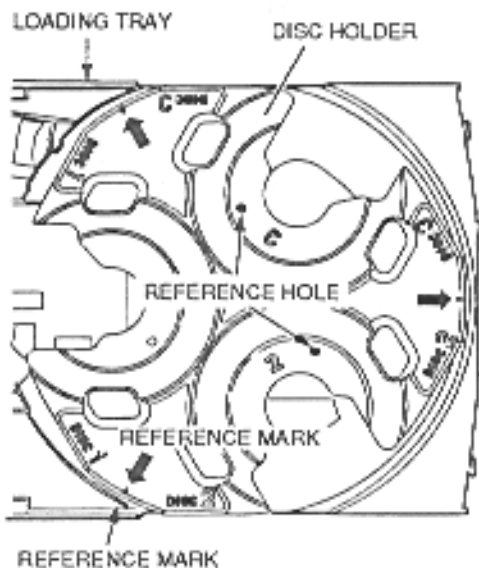

Fig. 3-11

Next, move the head of the GEAR HOLDER PART in the direction of the arrow before engaging the stoppers as shown in Fig. 3-12.

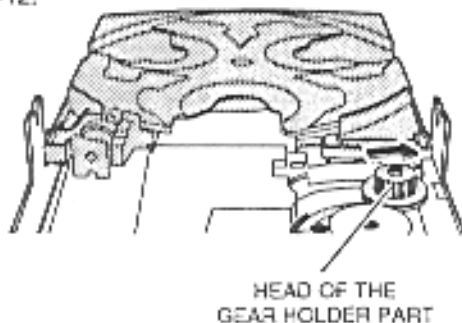

Fig. 3-12

3-1-6. Replacement of the TABLE MOTOR

- 1) Remove the TRAY BLOCK (refer to section 3-1-5).
- 2) Remove the DISC HOLDER retaining screw then remove the DISC HOLDER.

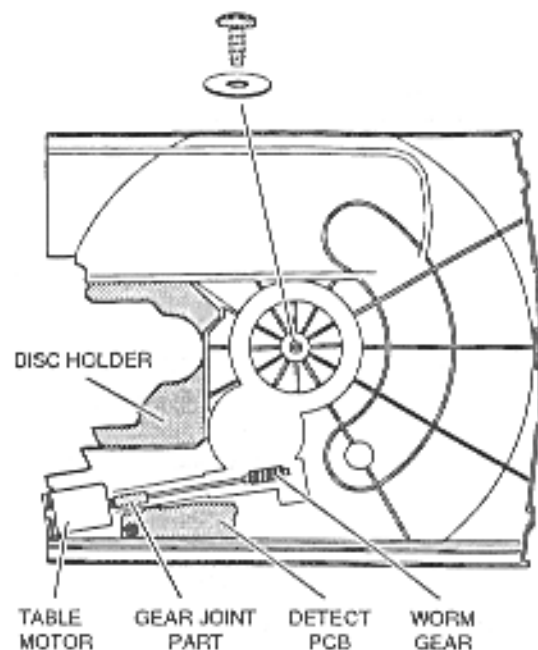

Fig. 3-13

- 3) Unsolder the leads of the TABLE MOTOR and remove the TABLE MOTOR PCB.

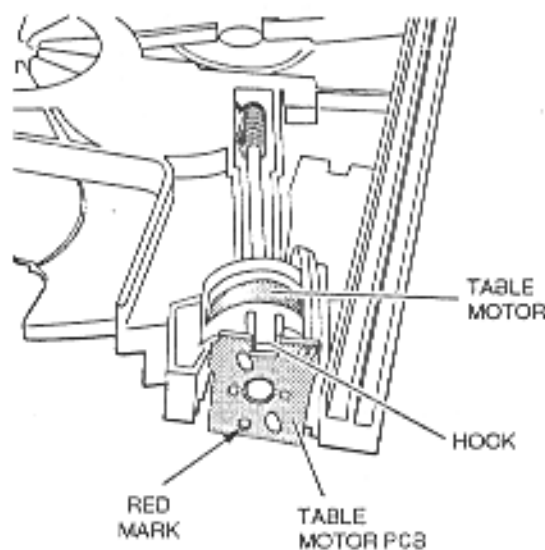

Fig. 3-14

- 4) Remove the TABLE MOTOR by pulling it out while opening the TABLE MOTOR retaining hook. Next, remove the WORM GEAR BLOCK by pulling the GEAR JOINT PART out and attach it to the new motor as shown in Fig. 3-13.
- 5) Reassemble in the reverse order.
 - When soldering the TABLE MOTOR PCB on the TABLE MOTOR, the TABLE MOTOR's red mark must be visible through the hole on the TABLE MOTOR PCB.
 - When attaching the DISC HOLDER on the LOADING TRAY, make sure to place the DISC HOLDER so that any one of the three reference marks aligns with the reference mark on the LOADING TRAY (any two reference holes on the DISC HOLDER align with the corresponding reference holes on the LOADING TRAY accordingly). (Refer to Fig. 3-11)

3-2. TAPE-I & TAPE-II MECHANISM BLOCK

* If CASSETTE MECHANISM BLOCK removal is intended, press both the "EJECT" buttons on the FRONT PANEL to open the CASSETTE HOLDERS and CASSETTE DOOR before proceeding (AC-600/603R/605K only).

3-2-1. Removal of the MECHANISM BLOCK

- 1) Remove the FRONT PANEL BLOCK.
- 2) Remove the four screws for each of the TAPE-I and TAPE-II MECHANISM BLOCKs then remove the MECHANISM BLOCKs from the FRONT PANEL BLOCK.

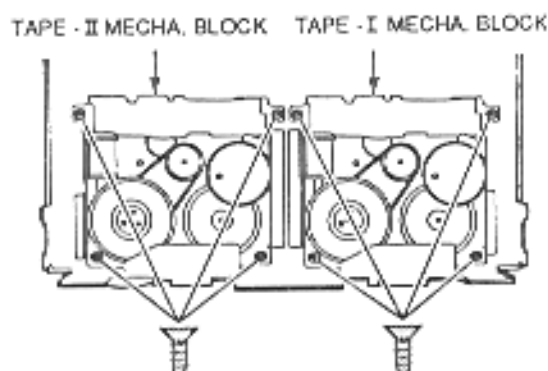

Fig. 3-15

3-2-2. Replacement of the CAPSTAN MOTOR

NOTE :After replacement, tape speed adjustment must be performed.

- 1) Unsolder the flat cable on the CAPSTAN MOTOR with a soldering iron.
- 2) While pressing the INTER-LOCK LEVER in the direction of the arrow, remove the two (B) screws and then remove the CAPSTAN MOTOR.

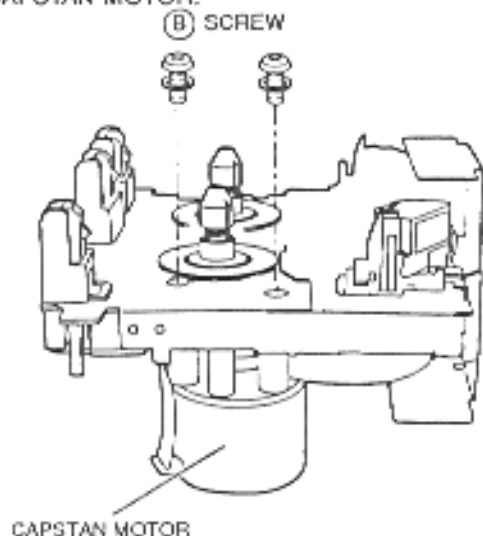

Fig. 3-16

- 3) Install a new motor and re-assemble in the reverse order for installation.

3-2-3. Replacement of the FR BELT

- 1) Unthread the MAIN BELT and replace the FR BELT as shown in Fig. 3-17.
- 2) Proceed in the reverse order for installation.

3-2-4. Replacement of the MAIN BELT

- 1) Remove the CAPSTAN MOTOR
- 2) Replace the MAIN BELT and re-assemble in the reverse order for installation.

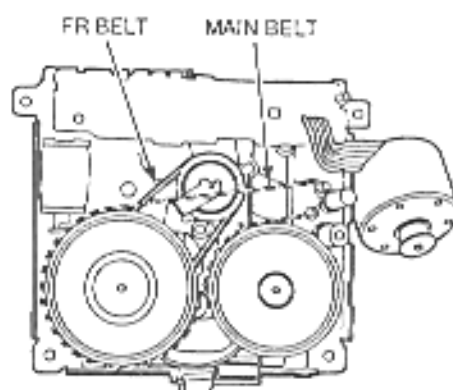

Fig. 3-17

- 3) After replacement, check the tape speed and if the result is not satisfactory, tape speed adjustment must be performed.

3-2-5. Replacement of the PINCH ROLLER BLOCK

- 1) Extract the PINCH ROLLER BLOCK upwards while releasing the pinch roller retaining hook in the direction of the arrow.

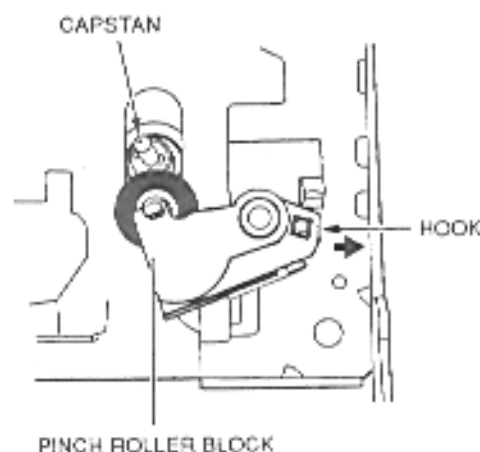

Fig. 3-18

- 2) Replace the PINCH ROLLER BLOCK and re-assemble in the reverse order. Attach the spring in the correct position when placing the PINCH ROLLER BLOCK.

3-2-6. Replacement of the PB HEAD OR REC/PB HEAD

- 1) Remove the two (A) screws and remove the HEAD SHIELD PLATE.

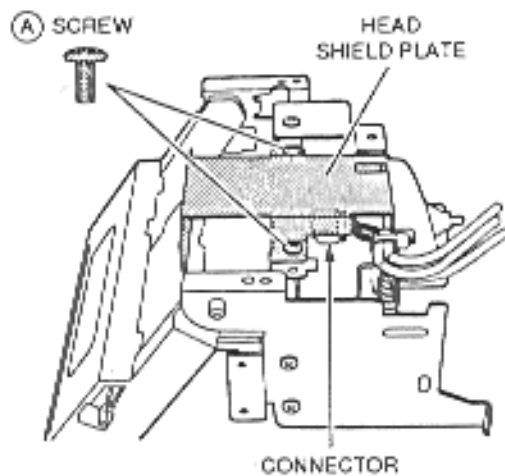

Fig. 3-19

- 2) Disconnect the connector on the CONNECTOR PCB and remove the PCB retaining screw.

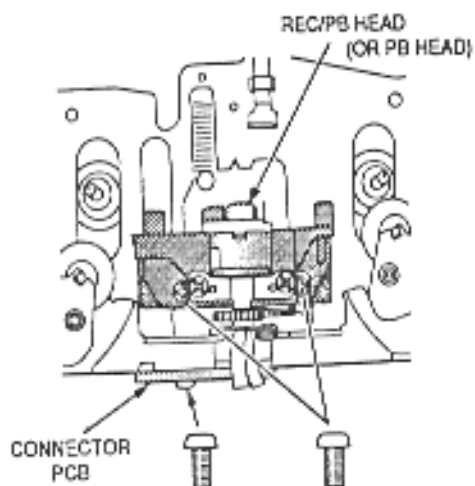

Fig. 3-20

- 3) Remove the two head retaining screws and remove the HEAD BLOCK.
- 4) Reassemble in the reverse order. After replacement, demagnetize the HEAD then perform head azimuth adjustment.

IV. MECHANICAL ADJUSTMENT

4-1. ADJUSTMENT OF THE HEAD AZIMUTH ALIGNMENT

- 1) Connect an oscilloscope to the L-ch and R-ch LINE terminals of the unit.
- 2) Play back a 10 kHz (-15 dB), HEAD AZIMUTH ALIGNMENT TEST TAPE (TF-106CH) then adjust the HEAD AZIMUTH ALIGNMENT Ⓐ (FWD PLAY) and Ⓑ (REV PLAY) SCREWS respectively so that the waveform level of both the L-ch and R-ch are at maximum and also they are in the same phase in both FWD and REV directions. (Use a sharp edge philips type screwdriver that is de-magnetized for adjustment.)
Perform the adjustment on both the TAPE-I and TAPE-II heads if necessary.

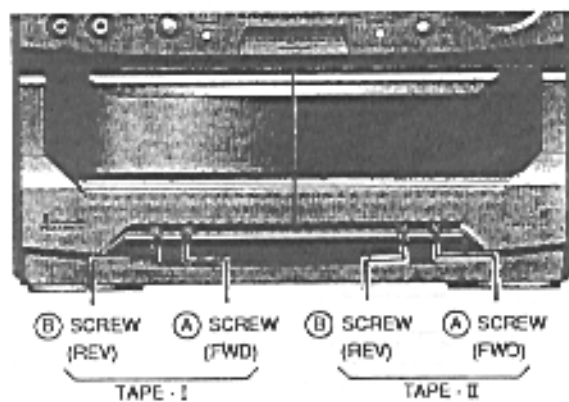

Fig. 4-1

V. ELECTRICAL ADJUSTMENT

5-1. TAPE DECK SECTION

NOTE :

- The following adjustment should be performed in the "DECK test mode".
To engage the DECK test mode, connect the AC power cord to the AC outlet while pressing the "TAPE-II" and "▶ (F)" buttons together.
When the "DECK test mode" is engaged, the "DUBX1" indicator on the FL display will light.
- When performing the tape speed adjustment, observe the following notes.
 - Adjustment should be started more than 30 seconds after the power is switched ON.
 - Adjustment should be made on X2 speed mode first then adjust the normal speed mode.
 - Adjustment should be made in the forward direction.
- To disengage the "DECK test mode", press the "POWER" button or unplug the AC power cord from the AC outlet.

STEP	ADJUSTMENT
1.	Test tape/input signal
2.	Mode
3.	Check point, adjustment part
4.	Remarks (•) and result (*):

Adjustment Part

Test Point

1	TAPE-I (X2) TAPE SPEED
1.	3,150 Hz test tape (TF-110CT)
2.	TAPE-I, PLAY
3.	LINE OUT, VR3100
4.	• Connect a frequency counter to the LINE OUT (L or R) and press the "DUBBING" button to engage double speed. * 6,340 ± 20 Hz

2	TAPE-I NORMAL TAPE SPEED
1.	3,150 Hz test tape (TF-110CT)
2.	TAPE-I, PLAY
3.	LINE OUT, VR3101
4.	• Connect a frequency counter to the LINE OUT and press the "▶ (F)" button again to resume normal tape speed. * 3,150 ± 10 Hz

3	TAPE-II (X2) TAPE SPEED
1.	3,150 Hz test tape (TF-110CT)
2.	TAPE-II, PLAY
3.	LINE OUT, VR3102
4.	• Press the "TAPE-II" button and play back the test tape. • Connect a frequency counter to the LINE OUT and press the "DUBBING" button to engage double speed. * 6,320 ± 20 Hz

4	TAPE-II NORMAL TAPE SPEED
1.	3,150 Hz test tape (TF-110CT)
2.	TAPE-II, PLAY
3.	LINE OUT, VR3103
4.	• Connect a frequency counter to the LINE OUT and press the "▶ (F)" button again to resume normal tape speed. * 3,140 ± 10 Hz

5	BIAS OSC FREQUENCY
1.	CrO2 type blank tape
2.	TAPE-II, REC
3.	P1004 @ pin, T1731
4.	• Connect a frequency counter between P1004 pin and GND. (10 : 1 probe should be used to avoid affecting the measurement.) • Start a recording (press the "REC" button then press the "▶" button). The "AUX" source indicator appears automatically. * 100.0 ± 0.2 kHz

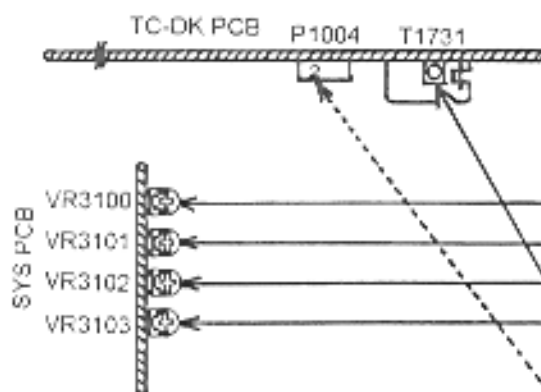

5-2.CD PLAYER SECTION

TEST MODE FOR CD PLAYER'S OPERATION

Some adjustments of the CD PLAYER section are automatically carried out by the micro computer.

If the CD player section is defective and it is necessary to partially check the operation, "CD TEST" mode can be used while repairing.

Engaging the "CD TEST" MODE

While pressing and holding both the "CD1" and "E-F" buttons, plug in the AC power cord to the AC outlet

Note :

- During "CD TEST" mode, only the DISC1 \blacktriangle open/close button can be used for loading. So, place a disc on "TRAY 1".
- Proceed testing by pressing the "CD1" button once for each testing step
- To disengage the "CD TEST" mode, press the "POWER ON/STANDBY" button or disconnect the AC power cord from the AC outlet.

DISPLAY	FUNCTION
T0 (TEST-0)	Initial condition of the "CD TEST" mode.
T1 (TEST-1)	Perform "focus search"
T2 (TEST-2)	Turn on the "focus servo".
T3 (TEST-3)	Mode of the "E-F balance" adjustment.
T4 (TEST-4)	E-F balance adjustment is carried out automatically and its data value is displayed on the FLD.
T5 (TEST-5)	Mode of the "Tracking gain" adjustment.
T6 (TEST-6)	Tracking gain adjustment is carried out automatically and its data value is displayed on the FLD.
T7 (TEST-7)	Normal playback mode is engaged.

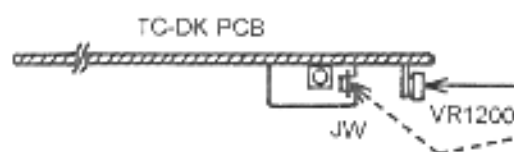

1	FOCUS OFFSET
1.	Test disc (SONY TYPE-III)
2.	Play back
3.	JW and VR1200
4.	Connect the hot side probe of an AC millivoltmeter to JW on the BIAS OSC PCB and GND side probe to the chassis. Adjust the VR1200 on the TC-DK PCB until indication of the AC millivoltmeter is maximum.

VI. PARTS LIST

ATTENTION

1. When placing an order for parts, be sure to list the part No. , Model No. and the description of each part. Otherwise, the nondelivery of the part or the delivery of a wrong part may result.
2. Please make sure that part No. is correct when ordering.
If not, a part different from the one you ordered may be delivered.
3. Since the parts shown in parts list of preliminary service manual may have been the subject of changes, please use this parts list for all future reference.

[NOTE]

1. This parts list lists those parts which are considered necessary for repairs. Other common parts, such as resistors and capacitors, are listed in the "Common List for Service Parts" from which these parts should be selected and stocked.
2. The Recommended Spare Parts list shows those parts in the parts list which are considered particularly important for service.
3. Parts not shown in the parts list and "Common List for Service Parts" will not in principle be supplied.

WARNING

 (*) INDICATED SAFETY CRITICAL COMPONENTS. FOR CONTINUED SAFETY, REPLACE SAFETY CRITICAL COMPONENTS ONLY WITH MANUFACTURE'S RECOMMENDED PARTS.

AVEERTISSEMENT

 (*) IL INDIQUE LES COMPOSANTS CRITIQUES DE SÉCURITÉ POUR MAINTENIR LE DEGRÉ DE SÉCURITÉ DE L'APPAREIL, NE REMPLACER QUE DES PIÈCES RECOMMANDÉES PAR LE FABRICANT.

1. REMOTE P.C. BOARD

REF. NO.	PARTS No.	DESCRIPTION
CF001	007-300455-46	RESONATOR CRK455 455KHz
IC001	033-806122-13	REMOTE TRANSMITTER UPD6122G-001
LED001	130-670303-00	INFRA RED EMITINT DIODE EL-1L1
PCB	090-010302-04	REMOTE BOARD T=1.6mm 94HB(46X119mm)
Q001	031-278050-03	TRANSISTOR NPN KTC8050C
D001-004	030-134148-00H	D SILICON IN4148
	210-010301-01S	REMOTE BATTERY COVER

2. SYS CON P.C. BOARD

REF. NO	PARTS No.	DESCRIPTION
D3001-3015/3080-3087	030-320131-01H	D SILICON H 1SS131T T52
D3102-3112/3121-3124		
D3016/3017/3120(for AC-620)	030-320131-01H	D SILICON H 1SS131T T52
D3113(AC-420/620 S1 AC-425K/625K Y7)	030-320131-01H	D SILICON H 1SS131T T52
D3114/3117(for AC-425/625K)	030-320131-01H	D SILICON H 1SS131T T52
D3115(for AC-420/620 S1)	030-320131-01H	D SILICON H 1SS131T T52
D3116(for AC-423/623RE1)	030-320131-01H	D SILICON H 1SS131T T52
D3119(AC-420/620 E1/E2/E3/B1/RE1)	030-320131-01H	D SILICON H 1SS131T T52
D3027-3031/3037/3038/3040-3044/3052/ D3053/3055/3056	030-560034-10	D LED MYB34C YELLOW
D3026-3029/3036/3039/3042/3051/3054 D3200-3211	030-540034-04	D LED MGB34D GREEN
D3020/3024/3025/3032-3035/3045-3049 D3021-3023	030-560031-00	D LED MYB31CA YELLOW
D3301/3302/3305-3307 (for AC-620/623R/625K)	030-510031-00	D LED MSB31TA RED
D3303/3304(for AC-620/623R/625K)	030-540034-04	D LED MGB34D GREEN
IC3001	030-560034-10	D LED MYB34C YELLOW
IC3002	034-801901-12	IC M38197MA-173FP TX3-SYS74-1
IC3003	033-509121-29	IC PST-9121 T05
IC3004	033-002401-42	IC XL24C01AP
IC3005-3007/3200	033-202011-14	IC TA2011S
IC3301(for AC-620/623R/625K)	034-304094-18	IC BU4094BCF
IC3100	034-304094-18	IC BU4094BCF
IC3101(for AC-423/623R)	033-304094-18A	IC BU4094BC
IC3102(for AC-423/623R)	034-106579-33	IC SAA6579T-T
IN3001	034-307073-16	IC LC7073M
J 3401	035-131610-00	IND FL SVA-16MM1D
J 3402(for AC-425/625K)	061-121406-00	PHONE J H5J1406-01-010 3.5
J 3003/3033	061-121406-00	PHONE J H5J1406-01-010 3.5
J 3022	060-406123-99	SOCKET 00 6216 006 000 6P
J3906-3907	060-423124-99	SOCKET 00 6216 023 100 23P
P 3301(AC-420/423R/425K)	060-615125-07	SOCKET 15FE-BT-VK-N 15P
P 3301A(AC-620/623R/625K)	060-103204-07	PLUG S3B-PH-K WHT 3P
P 3011	060-108204-07	PLUG S8B-PH-K WHT 8P
PH3001	060-422124-99	PLUG TKC-V22P-A1 22P
SW3001	036-600446-01	DETECTOR SPS-446-1
SW3002	040-002410-20	SW ROTARY EC16B24304
TR3003-3005/3125-3126	046-080001-00	SW PUSH VPS-800
TR3101/3103/3113-3120/3122-3123	031-440144-05V	DTR DTC144ES(47-47) T05
TR3100/3102/3104-3106	031-211048-25V	TR 2SA1048 Y,GR T05
TR3111(for AC-423RE1/623RE1)	031-224682-00V	TR 2SC4682
TR3112(for AC-423RE1/623RE1)	031-211048-25V	TR 2SA1048 Y,GR T05
TS3001-3004/3011-3301	031-440144-05V	DTR DTC144ES(47-47) T05
TS3005/3009	046-110201-00	SW TACT 1.T-1102A 160GM
VR3001	046-110201-00	SW TACT 1.T-1102A 160GM
VR3101/3103	011-202298-00	VR ROTARY RK11K1140 L17.5 B202
VR3100/3102	112-102311-05	R S-FIX V T05 EVND CAA 30.10W 102
	112-222311-05	R S-FIX V T05 EVND CAA 30.10W 222

W 3001(AC-420/423R/425K)
 W 3001A(AC-620/623R/625K)
 W 3007
 W 3008
 W 3011
 W 3401
 X 3001
 X 3002
 X 3100(for AC-423/623R)
 X 3101(for AC-423/623R)

063-552701-03
 063-552701-03
 077-622107-16
 077-622107-15
 077-622107-05
 078-125021-00
 007-208000-06
 037-032768-10M
 007-204000-06
 037-004332-10Z

WA PH-SAN L270 3P
 WA PH-SAN L270 3P
 WF 2468#26 P2.0 C09 L100 16P
 WF 2468#26 P2.0 C09 L100 15P
 WF 2468#26 P2.0 C09 L100 5P
 WA EARTH LUG L=200
 OSC CE CST8.00MTW 8 000MHZ
 OSC X'TAL C-002RX 32.768KHZ
 OSC CE CST4.00MGW 4.000MHZ
 OSC X'TAL HC-49/U-S 4.33200MHZ

3. MAIN P.C. BOARD

REF. NO.

PARTS No.

DESCRIPTION

D 001(AC-620/623R/625K)	△ 030-310040-02	D SILICON DBF40C 200/4 0A
D 002(AC-620/623R/625K)	△ 030-310040-02	D SILICON DBF40C 200/4 0A
D 003-004/025(AC-620/623R/625K)	030-410056-30H	D ZENER MTZJ5.6C T52
D 005-008(AC-620/623R/625K)	△ 030-310152-06	D SILICON RL152M11S15 100/1.5A
D 006-009(AC-420/423R/425K)	△ 030-310152-06	D SILICON RL152M11S15 100/1.5A
D 021/023/081/086/087/	030-314002-10H	D SILICON 1N4002-F T52 100/1A
D 231/232(AC-420/423R/425K)		
D 021/023/081-083/141(AC-620/623R/625K)	030-314002-10H	D SILICON 1N4002-F T52 100/1A
D 001/022/024/042/044/046/083/	030-320131-01H	D SILICON H 1SS131T T52
D 121-124/141-143/221/724 (AC-420/423R/425K)		
D 022/024/041-042/047/130-131/135-136	030-320131-01H	D SILICON H 1SS131T T52
D 133/142/153-154/156-157		
D 322/724(AC-620/623R/625K)		
D 025/063/066/145/721-723/	030-410062-10H	D ZENER MTZJ6.2A T52
D 751-753(AC-420/423R/425K)		
D 043/062/721-723(AC-620/623R/625K)	030-410062-10H	D ZENER MTZJ6.2A T52
D 041	030-410075-10H	D ZENER MTZJ7.5C T52
D 044/151-152(AC-620/623R/625K)	030-410075-10H	D ZENER MTZJ7.5C T52
D 004/005/043/085/144 (AC-420/423R/425K)	030-410051-20H	D ZENER MTZJ5.1B T52
D 045(AC-620/623R/625K)	030-410051-20H	D ZENER MTZJ5.1B T52
D 046(AC-620/623R/625K)	030-410015-03H	D ZENER MTZJ15B T52
D 084	030-410330-00H	D ZENER MTZJ33B T52
D 085(AC-620/623R/625K)	030-410056-20H	D ZENER MTZJ5.6A T52
D 132/134(AC-620/623R/625K)	030-410220-00H	D ZENER MTZJ22D T52
D 155(AC-620/623R/625K)	030-410051-10H	D ZENER MTZJ5.1A T52
D 531-533/551-554(for AC-625K)	030-320131-01H	D SILICON H 1SS131T T52
D 551-554(for AC-425K)	030-320131-01H	D SILICON H 1SS131T T52
F1(for AC-420/423R/425K)	△ 082-221600-06	FUSE TIME 218 250V 1.6A
F2(for AC-425K)	△ 082-221600-06	FUSE TIME 218 250V 1.6A
F1(for AC-620/623R/625K)	△ 082-222000-06	FUSE TIME 218 250V 2.00A
F2(for AC-625K)	△ 082-222000-06	FUSE TIME 218 250V 2.00A
F3(for AC-620/623R/625K)	△ 082-225000-06	FUSE TIME 218 250V 5.00A
F4(for AC-620/623R/625K)	△ 082-225000-06	FUSE TIME 218 250V 5.00A
IC 021	033-507805-00B	IC ML7805FA 5V/1A
IC 201(AC-420/423R/425K)	030-404142-16	IC STK4142-2
IC 202/203/204(AC-620/623R/625K)	033-218751-38	IC S118751
IC 501	033-K65843-12	IC M65843AFP
IC 581	033-904558-30A	IC NJM4558L
IC 602(for AC-620/623R/625K)	034-K02177-74	IC NJM2177AFB3
IC 701	034-262422-12	IC M62422FP
IC 751/761 (for AC-620/623R/625K)	033-209412-14	IC TC9412P
IC 761 (for AC-420/423R/425K)	033-209260-14	IC TC9260P
IC 101(for AC-420/423R/425K)	033-304094-18A	IC BU4094BC
IC 801	033-304094-18A	IC BU4094BC

IC 802 (for AC-620/623R/625K)	033-304094-18A	IC BU4094BC
J 011	060-422122-99	SOCKET TKC-V22X-A1 22P
J 201	061-123000-00	PHONE J HSJ3000-01-010 3.5
J 301 (only for AC-620/623R/625K)	061-780243-00	PIN J HSP-243V-06 3P
L 201/251(AC-420/423R/425K)	004-285103-08	COIL 202AK018K COILS
L 281(AC-420/423R)	0844-070410-00	COIL BALUM OPW/S-8-14-5H2
L 202(for 620/623R)	084-070410-00	COIL BALUM OPW/S-8-14-5H2
L 203(for AC-620/623R)	084-070410-00	COIL BALUM OPW 15-8-14-5H2
L 801	002-300002-09	COIL LF LF-4D-102 102UH
P 006(for AC-420/423R/425K)	060-112204-07	PLUG S12B-PH-K WHT 12P
P 006(for AC-620/623R/625K)	060-116204-07	PLUG S16B-PH-K WHT 16P
P 012(AC-420/423R/425K)	060-102045-20	PLUG B2P-3-VH P7.92 2P
P 012(for AC-620/623R/625K)	060-107204-07	PLUG S7B-PH-KWHT 7P
P 013(for AC-420/423R/425K)	060-403001-17	PLUG RB-115-3P 3P
P 013(for AC-620/623R/625K)	060-107045-20	PLUG PS2438-7 7P
P 014(AC-420/423R/425K)	060-104205-27	PLUG B4B-PH-K WHT 4P
P 801(AC-620/623R/625K)	060-102045-20	PLUG B2P-3-VH P7.92 2P
P 902(AC-420/423R/425K)	060-403001-17	PLUG RTB-1.5-SP 3P
R 004-005/043	⚠ 013-478205-75	R OMF H S10FLR ERG12SP1/2WR47J
R 021/103/106/109/112	⚠ 013-109205-75	R OMF H S10FLR ERG12SP1/2W1R0J
R 080(AC-620/623R/625K)	⚠ 013-109205-75	R OMF H S10FLR ERG12SP1/2W1R0J
R 081(AC-420/423R/425K)	⚠ 013-478205-75	R OMF H S10FLR ERG12SP1/2WR47J
R 047-048	⚠ 013-221205-75	R OMF H S10FLR ERG12SP1/2W221J
R 060-063(AC-620/623R/625K)	⚠ 013-392205-75	R OMF H S10FLR ERG12SP1/2W392J
R 061/062-064(AC-420/423R/425K)	⚠ 013-102205-2A	R OMF H S10FLR ERG12SP1/2W102J
R 132/135-136/141(AC-620/623R/625K)	⚠ 013-151205-75	R OMF H S10FLR ERG12SP1/2W151J
R 137(AC-620/623R/625K)	⚠ 013-478205-75	R OMF H S10FLR ERG12SP1/2W562J
R 213/263/233/283 (for AC-620/623R/625K)	⚠ 013-479305-75	R OMF H S12 FLR ERG1SP 1W 4R7J
R 209/210/259/260(AC-420/423R/425K)	013-478205-075	R OEM H SLOFER ERG15P 1W 100J
RL001	⚠ 066-110212-04	RELAY POWOSA-SS 212DM5 TV-3
TM 201	061-780401-00	TERMINAL PUSH C.J-9007-060 4P
TR 022/024/026/043	031-440114-05V	DTR DTC114ES(10-10) T05
TR 131(AC-620/623R/625K)	031-440114-05V	DTR DTC114ES(10-10) T05
TR 221(AC-420/423R/425K)	031-440114-05V	DTR DTC114ES(10-10) T05
TR 023(for AC-420/423R/425K)	031-221443-00V	TR 2SB1443 TV2
TR 023(for AC-620/623R/625K)	031-220621-00V	TR2SB621 R,S T05
TR 025	031-220621-00V	TR 2SB621 R,S T05
TR 021/041/082/101-104	031-211048-25V	TR 2SA1048 Y,GR T05
TR 130/132(AC-620/623R/625K)	031-211048-25V	TR 2SA1048 Y,GR T05
TR 044/081	031-221375-00	TR 2SB1375
TR 061(AC-620/623R/625K)	031-440114-60V	DTR DTC114TS(10) T05
TR 121-124(AC-420/423R/425K)	031-440114-60V	TR DTC114JS107 T05
TR 134(for AC-610/613R/615K)	031-241785-00	TR 2SD1785
TR 045/135/151/152/154/155/201/251	031-232458-25V	TR 2SC2458 Y,GR T05
TR 221/271(AC-620/623R/625K)		
TR 045/141/201-203/251-253 (for AC-420/423R/425K)	031-232458-25V	TR 2SC2458 Y,GR T05
TR 137(for AC-620/623R/625K)	031-221258-00	TR 2SB1258
TR 153(for AC-620/623R/625K)	031-430114-19V	DTR DTA114TS(10) T05
TR 158(for AC-620/623R/625K)	031-440114-60V	DTR DTC114TS(10) T05
TR 320/321(for AC-620/623R/625K)	031-430114-05V	DTR DTA114ES(10-10) T05
TR 322(for AC-620/623R/625K)	031-440114-60V	DTR DTC114TS(10) T05
TR 531(for AC-625K)	031-430114-19V	DTR DTA114TS(10) T05
TR 532/533/535/536/539-541 (for AC-625K)	031-440144-60	DTR DTC144TS(47) T05
TR 534/537/538(for AC-625K)	031-440114-60V	DTR DTC114TS(10) T05
TR 551/552(for AC-425K/625K)	031-440114-60V	DTR DTC114TS(10) T05

TR 601-604(AC-620/623R/625K)
 W 014(AC-420/423R/425K)
 W 801(for AC-425K/625K)
 W 913(for AC-620/623R/625K)
 X 501(only for AC-620/623R/625K)
 X 551(for AC-425K/625K)

031-430114-19V
 063-552301-04
 063-502401-11
 063-553201-07
 007-002000-40
 007-200400-03

DTR DTA114TS(10) T05
 WA SAN-PH #24 C230 4P
 WA SDN L200 6P
 WA SDN-VH #22 L320 7P
 OSC CE CSA2.00MG 2.000MHZ
 OSC CE DCRK400 400.000KHZ

4. TC-DK P.C. BOARD

REF. NO.

D 1300-1304
 D 1400/1401/1721
 D 1501
 FL1611/1621/1661/1671
 IC1001
 IC1002/1210
 IC1003(for AC-620/623R/625K)
 IC1100
 IC1200
 IC1300
 IC1400
 IC1601
 IC1701/1702
 J 1001(for AC-420/423R/425K)
 J 1001A(for AC-620/623R/625K)
 J 1002
 J 1100
 L 1501(S1/U5/U8/Y6/Y7/A3)
 L 1721
 P 1004
 P 1005
 P 1200
 P 1400
 P 1401
 P 1402
 T 1731
 TM1501
 TR1100/1400/1102/1743
 TR1300/1301
 TR1302/1601/1621/1651/1671/
 TR1741/1721/1742/1751/1752/1756
 TR1401/1501/1611/1612/1661-1662/1701
 TR1502(for AC-423R/623R)
 TR1613/1663
 TR1010/1060/1631/1685/1642/1101/
 TR1035/1681/1692
 TR1641/1643/1691/1693
 (for AC-620/623R/625K)
 TR1723-1725
 TR1726(E1/E2/B1/RE1/E3)
 TR1731-1732(E1/B1/RE1/E3)
 TU1501(E1/E2/B1/RE1/E3)
 TU1501A(S1/U5/U8/Y6)
 TU1501B(Y7)
 VR1200
 W 1006
 W 1400/1401
 X 1200
 W900
 W1500

PARTS No.

030-314002-10H
 030-320131-01H
 030-410051-10H
 007-100100-09
 033-314052-21
 033-904558-30A
 033-314053-21
 033-601782-64Q
 033-K02508-64
 033-209258-61
 033-206247-18
 034-101897-64
 034-304094-18
 061-782441-00
 061-782441-00
 060-423123-99
 060-416109-99
 005-229056-01H
 005-101056-00H
 060-108205-27
 060-103205-27
 036-400032-01
 060-105204-27
 060-107204-29
 060-106206-27
 002-800002-09
 061-480312-00
 031-211048-25V
 031-221425-00V
 031-440114-05V

 031-232458-25V
 031-250304-06V
 031-241012-06V
 031-440114-60V

 031-440114-60V

 031-231815-26V
 031-211048-25V
 031-232458-25V
 103-146601-04
 103-146401-04
 103-146101-04
 112-103311-05
 063-B01001-12
 077-322087-09
 037-169344-30J
 077-955168-16
 072-122008-50

DESCRIPTION

D SILICON 1N4002-F T52 100/1A
 D SILICON H 1SS131T T52
 D ZENER MTZJ5.1A T52
 COIL TUN 1 100Z-121 100.00KHZ
 IC MC14052BCP
 IC NJM4558L
 IC MC14053BCP
 IC CXA1782BQ
 IC CXD2508AQ
 IC KA9258D
 IC BA6247
 IC CXA1897Q
 IC BU4094BCF
 PIN J HSP-244V1-05 2P
 PIN J HSP-244V1-05 2P
 SOCKET 00 6216 023 000 23P
 SOCKET 00 6232 016 006 16P
 COIL FIX 1 LAP02TA T26 2R2J
 COIL FIX 1 LAP02TA T26 101J
 PLUG B8B-PH-K WHT 8P
 PLUG B3B-PH-K WHT 3P
 SOCKET OPTICAL GPIF32T
 PLUG S5B-PH-K WHT 5P
 PLUG S7B-PH-K WHT 7P
 PLUG S6B-PH-K WHT 6P
 COIL OSC 1 C1047
 TERMINAL LEVER HSP-312V-02
 TR 2SA1048 Y,GR T05
 TR 2SB1425 S,E T05
 DTR DTC114ES(10-10) T05

 TR 2SC2458 Y,GR T05
 TR FET 2SK304 E,F T05
 TR 2SD1012-V-SPA-AC F,G,H T05
 DTR DTC114TS(10) T05

 DTR DTC114TS(10) T05

 TR 2SC1815 Y,GR T05
 TR 2SA1048 Y,GR T05
 TR 2SC2458 Y,GR T05
 TUNER TFCB3E720A FM/MW/LW
 TUNER TFCB1U717A FM/AM
 TUNER TFCB1S713A FM/MW/SW
 R S-FIX V T05EVNDCAA3 0.10W103
 WA PH L100 12P
 WF 2468#26 P2.0 C09 L80 9P
 OSC XTALHO-49/U16934.400KHZ
 CORD FFC P1.0 L150 16P
 WD 1007#22 CO 180

5. P.C. BOARD BLOCK

REF. NO.	PARTS No.	DESCRIPTION
1-a(AC-420/423R)	771-AC42001-01	MAIN P.C. BOARD
1-b(AC-425K)	771-AC42001-46	MAIN P.C. BOARD
1-c(AC-420/423R)	771-AC42001-02	PRI. P.C. BOARD
1-d(AC-425K)	771-AC42001-47	PRI. P.C. BOARD
1-e(AC-420/423R/425K)	771-AC42001-03	SEC. P.C. BOARD
2-a(AC-420 B1/E1/E3)	771-AC42001-04	TC-TU/CD/DK P.C. BOARD
2-b(AC-420/425K)	771-AC42001-27	TC-TU/CD/DK P.C. BOARD
2-c(AC-423R)	771-AC42001-38	TC-TU/CD/DK P.C. BOARD
2-d(AC-425K Y7)	771-AC42001-82	TC-TU/CD/DK P.C. BOARD
2-e(AC-420/423R)	771-AC42001-05	TC-OSC P.C. BOARD
2-f(AC-420/425K)	771-AC42001-28	TC-OSC P.C. BOARD
2-g(AC-420/423R/425K)	771-AC42001-06	TC-RELAY P.C. BOARD
3-a(AC-420/423R/425K)	771-AC42001-07	SYS-SYS FLD P.C. BOARD
3-b(AC-420 B1/E1/E3)	771-AC42001-08	SYS-MECH CON P.C. BOARD
3-c(AC-420 S1)	771-AC42001-31	SYS-MECH CON P.C. BOARD
3-d(AC-423R)	771-AC42001-42	SYS-MECH CON P.C. BOARD
3-e(AC-425K U5/U8/Y6)	771-AC42001-53	SYS-MECH CON P.C. BOARD
3-f(AC-420/425R/425K)	771-AC42001-09	SYS-MECH CON P.C. BOARD
3-g(AC-420/423R/425K)	771-AC42001-10	SYS-MECH CON P.C. BOARD
3-h(AC-420/423R)	771-AC42001-11	SYS-MIC JACK P.C. BOARD
3-i(AC-425K)	771-AC42001-56	SYS-MIC JACK P.C. BOARD
4a(AC-420)	790-010301-01	REMOTE P.C. BOARD
4b(AC-620)	790-010302-01	REMOTE P.C. BOARD
5-a(AC-620/623R)	771-AC62001-01	MAIN P.C. BOARD
5-b(AC-625K)	771-AC62001-46	MAIN P.C. BOARD
5-c(AC-620/623R)	771-AC62001-02	PRI. P.C. BOARD
5-d(AC-625K)	771-AC62001-47	PRI. P.C. BOARD
5-e(AC-620/623R/625K)	771-AC62001-03	PRI. P.C. BOARD
6-a(AC-620 B1/E1/E3)	771-AC62001-04	TC-TU/CD/DK P.C. BOARD
6-b(AC-620 S1 AC-625K U5/U8/Y6/Y7)	771-AC62001-27	TC-TU/CD/DK P.C. BOARD
6-c(AC-623R)	771-AC62001-38	TC-TU/CD/DK P.C. BOARD
6-d(AC-625K Y7)	771-AC62001-82	TC-TU/CD/DK P.C. BOARD
6-e(AC-620/623R)	771-AC62001-05	TC-OSC P.C. BOARD
6-f(AC-620/623R)	771-AC62001-28	TC-OSC P.C. BOARD
6-g(AC-620/623R/625K)	771-AC62001-06	TC-RELAY P.C. BOARD
7-a(AC-620/623R/625K)	771-AC62001-07	SYS-SYS LED P.C. BOARD
7-b(AC-620 B1/E1/E3)	771-AC62001-08	SYS-MECH CON P.C. BOARD
7-c(AC-620 S1)	771-AC62001-31	SYS-MECH CON P.C. BOARD
7-d(AC-623R)	771-AC62001-42	SYS-MECH CON P.C. BOARD
7-e(AC-625K U5/U8/Y6)	771-AC62001-53	SYS-MECH CON P.C. BOARD
7-f(AC-625K Y7)	771-AC62001-86	SYS-MECH CON P.C. BOARD
7-g(AC-620/623R/625K)	771-AC62001-09	SYS-DECK LED P.C. BOARD
7-h(AC-620/623R/625K)	771-AC62001-10	SYS-CDOPE P.C. BOARD
7-i(AC-620/623R)	771-AC62001-11	SYS-MIC JACK P.C. BOARD
7-j(AC-625K)	771-AC62001-56	SYS-MIC JACK P.C. BOARD

6. YMC03 P.C. BOARD

REF. NO.	PARTS NO.	DESCRIPTION
D4410	030-600048-00	D LED GL4800
TR4410	031-594800-00	TR PHOTO PT4800
J4410	060-405124-99	SOCKET 0062160051005 5P
J4411	060-405123-99	SOCKET 0062160051005 5P
W4401	077-622077-02	WF2468# P I O C09L072P
W4412	063-555301-05	WA SAN-PHL 530 5P

7. ACCESSARY REF. NO.

REF. NO.	PARTS. No.	DESCRIPTION
1	790-010301-01	REMOCON RC-S520
2	790-010302-01	REMOCON RC-S720

8. CD MECHANISM

REF. NO.	PARTS NO.	DESCRIPTION
1	229-385602-01S	HOLDERDISC
2	288-385601-01Z	GEAR WORMWHEEL TABLE
3	220-385602-01S	TRAY LOADING
4	438-385601-01	SHAFT
5	288-385604-01Z	WORM
6	239-385601-01Z	JOINT
7	743-037012-54	MOTOR PF-370CA-15370 12V
8	634-150030-08	PW30X150X080 THK
9	619-300208-00	TAPING SCREW 3X1 25X8mm
10	288-385605-01Z	GEAR LOADING (A)
11	288-385606-01Z	GEAR LOADING(B)
12	288-385602-01Z	PULLEY GEAR
13	334-385604-01	BELT LOADING
14	288-385603-01S	HOLDER GEAR
15	615-300308-00	BWT 3X8mm
16	428-385603-01	PLATE CLAMPER
17	489-383801-01	MAGNET DISC CLAMP
18	229-385606-01S	CLAMPER
19	259-385602-01Z	ROLLER
20	047-102127-00	LEAF SWITCH LSA-2127E
21	243-385601-01Z	PULLEY
22	743-050009-54	MOTOR RF-500TB-14415 DV
23	047-101119-01	LEAF SWITCH ISA-1119H
24	610-260208-10	R/T 2.6X8mm
25	220-385601-01S	HOLDER TRAVERSE
26	334-385606-01	INSULATOR
27	334-385606-01	INSULATOR
28	610-200216-00	SELF-SCREW TAPING B/T 2.0X16
29	747-021301-02	MECHA TRAVERSE KSM213CCM
30	220-385603-01R	CHASSIS MAIN
31	219-385601-01Z	CD MECH COVER
32	634-100027-05	METAL WASHER 10X2.7X0.5

CD MECHANISM BLOCK

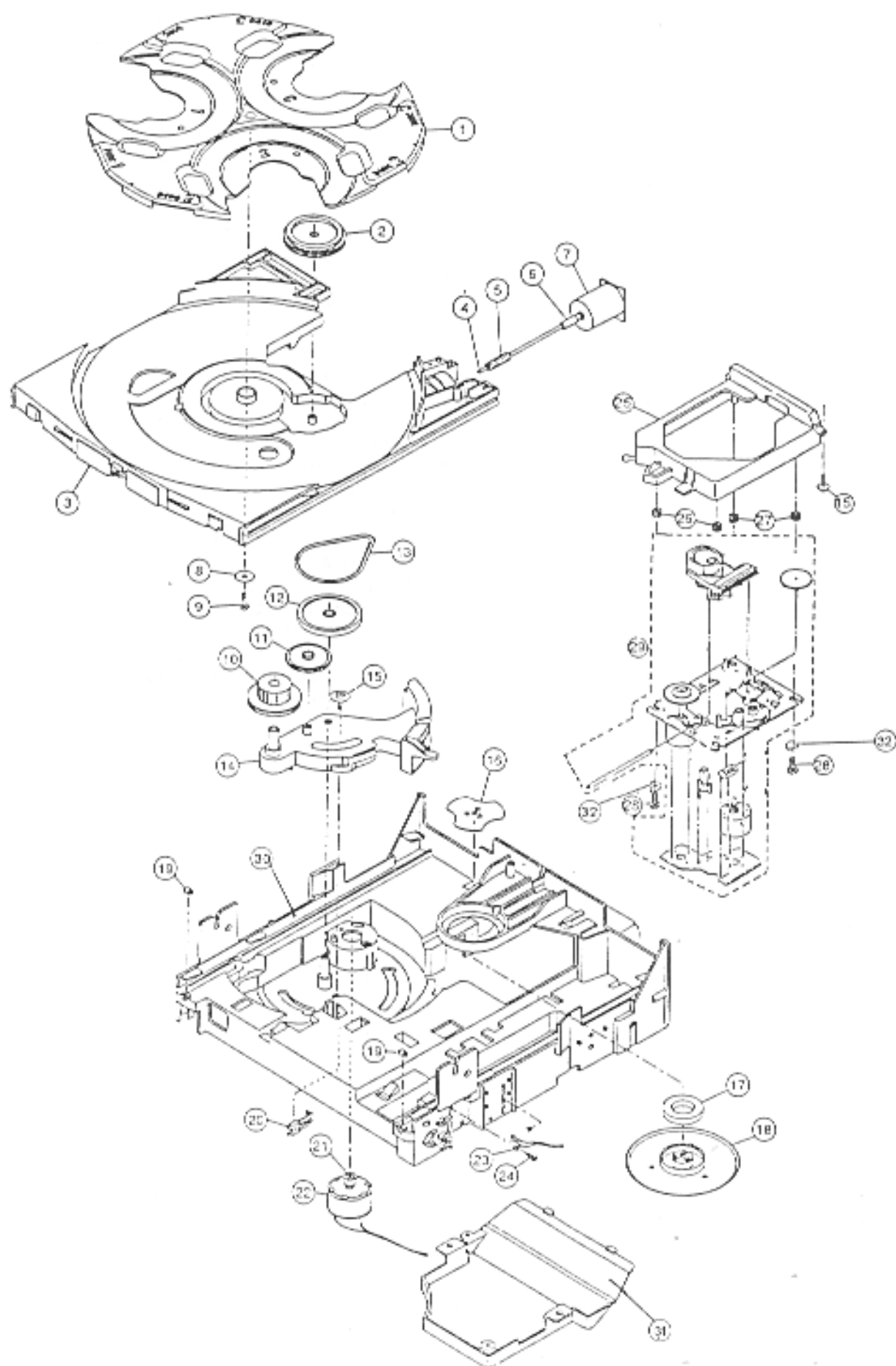

9. AC-420/423R/425K

REF. NO.	PARTS NO.	DESCRIPTION
1	606A301208-00	TAPING SCREW P TYPE BID H 3X1.25PX8MM
2	606A301208-00	TAPING SCREW P TYPE BID H 3X1.25PX8MM
3	402-385002-02	MAIN COVER SILVER
4	495-385017-01	REAR CABINET SUB
5	284-385001-01R	MECH SPACER BLACK HI-PS
6	619-300208-00	TAPING SCREW P TYPE BID H 3X8MM BLACK
7	619-300208-00	TAPING SCREW P TYPE BID H 3X8MM BLACK
8	619-300208-00	TAPING SCREW P TYPE BID H 3X8MM BLACK
9	428-385001-01	CD BRACKET 'L'
10	619-300208-00	TAPING SCREW P TYPE BID H 3X8MM BLACK
11	619-300208-00	TAPING SCREW P TYPE BID H 3X8MM BLACK
12	292-AA0302-01S	DOBLY BUTTON
13	229-AA0301-01S	FLD BRACKET HI-PS
14	291-AA0302-01S	FUNCTION BUTTON ABS
15	291-AA0303-01Z	BALANCE BUTTON GRAY
16	291-AA0306-01Z	OP BUTTON (AC-420)
17	250-AA0301-01S	LAMP HOLDER WHITE ABS
18	292-AA0301-01S	REC BUTTON RED (P-96014) ABS
19	291-AA0301-01S	CH BUTTON DARK GREY (P-92008) ABS
20	291-AA0305-01S	POWER BUTTON DARK GREY (P-92008) W/MET GREY(T-96008HB) SP. SILK'S RED(S-88011) LETT. ABS
21	229-AA0314-01Z	LATCH BRACKET (L) POM
22	291-AA0301-01S	DISC BUTTON DARK GREY (P-92008)
23-a(AC-420)	200-AA0311-01R	FRONT CABINET HI-PS
23-b(AC-423R)	200-AA0311-02R	FRONT CABINET HI-PS
23-c(AC-425K)	200-AA0312-01R	FRONT CABINET HI-PS
24	275-AA0301-01S	TIMER BUTTON DARK GREY (P-92008) ABS
25	261-AA0301-01K	CASS DOOR LENS (L) SMOKE
26	273-AA0302-01S	VOLUME RING DARK GREY (P-92008) W/PLATTING ABS
27	219-AA0311-01R	CD DOOR HI-PS
28	286-385001-02S	NAME PLATE 'AKAI'
29	263-AA0301-02K	DISPLAY LENS AS
30	229-385016-01Z	LATCH BRACKET BLACK POM
31	619-300210-00	TAPPING SCREW P TYPE BID H 3X10MM BLACK
32	273-AA0301-01S	VOLUME KNOB ABS
33	619-300210-00	TAPING SCREW P TYPE BID H 3X10MM BLACK
34	211-AA0301-01S	CASS DOOR (L) HI-PS
35	418-AA0301-01	OVERLAY CLEAR SILK'S WHITE(S-96001) COLOR PVC
36	291-AA0304-01S	BASS BUTTON MILKY WHITE (CL-301) ABS
37	273-AA0303-01S	DARK GRAY ABS
38	606A301208-00	TAPING SCREW P TYPE BID H 3X1.25PX8MM
39	606A301208-00	TAPING SCREW P TYPE BID H 3X1.25PX8MM
40	614-300208-00	SELF-TAPPING SCREW B/T 3X8MM BLACK
41	606A301208-00	TAPING SCREW P TYPE BID H 3X1.25PX8MM
42-a(AC-420 E/B)	495-AA0301-01	PANEL REAR
42-b(AC-420 S)	495-AA0301-02	PANEL REAR
42-c(for AC-423R(E))	495-AA0301-03	PANEL REAR
42-d(AC-425K U5,Y6)	495-AA0302-01	PANEL REAR
42-e(AC-425K U8,Y7)	495-AA0302-01	PANEL REAR
43	650-381301-01	CORD BUSHING
44	663-076040-10S	SPRING WASHER 7.6X4X1MM THK SIL CMT
45	207-385101-01Z	REAR FOOT (PLASTIC) BLACK EVA
46	619-300208-00	TAPING SCREW P TYPE BID H 3X8MM BLACK

47	211-AA0502-02S	CASS DOOR PALTE (R)-B BLACK
48	428-385101-01	HOLDER BRACKET (H)
49	481-385102-01	HEAT SINK (H-2)
50	493-385112-01	METAL BOTTOM CABINET (H) 1MM
51	261-AA0302-01K	CASS DOOR LENS (R) SMOKE
52	428-385002-01	CD BRACKET 'R'
53	619-300208-00	TAPING SCREW P TYPE BID H 3X8MM BLACK
54	619-300208-00	TAPING SCREW P TYPE BID H 3X8MM BLACK
55	477-385011-01	LATCH PUSH SPRING
56	483-AA0301-01	SHIELD HEAD
57	604-264501-00A	TAPPING SCREW C TYPE BID 2.6X5MM
58	299-AA0312-01S	LID BRACKET TX-3 WHITE ABS
59	229-AA0303-01S	LID BRACKET BLACK ABS
60	330-385001-01	FRONT CUSHION FOOT
61	619-300208-00	TAPING SCREW P TYPE BID H 3X8MM BLACK
62	602-407006-60A	TAPPING SCREW P TYPE WASHER H 4X8MM
63	619-300212-00	TAPPING SCREW P TYPE BID H 3X12MM
64	703-385002-01	DAMPER DA-60WW (105) ASSEMBLY
65	263-AA0303-01K	DECK DIR LENS AS
66	229-AA0315-01Z	LATCH BRACKET (R) POM
67	470-AA0321-01	CASS DOOR SPRING SHEET
68	211-AA0302-01S	CASS DOOR (R) HI-PS
69	471-AA0302-01	CASS DOOR SPRING WIRE (R)
70	471-AA0301-01	CASS DOOR SPRING WIRE (L)
71	211-AA0501-02S	CASS DOOR PALTE (L)-B BLACK
72-a(AC-420/423R)	001-86AA03-22	POWER TRANSFORMER C1058-E
72-b(AC-425K)	001-86AA03-B2	POWER TRANSFORMER C1058-U
73	741-495300-09	LOGICAL CONTROL DECK MECHA GT-E5300 (P/B)
74	741-495600-09	LOGICAL CONTROL DECK MECHA GT-E5600(R/P)
75	606A301208-00	TAPING SCREW P TYPE BID H 3X1 25PX8MM
76	619-300210-00	TAPINET SCREW P TYPE BID H 3X10MM BLACK
77-a(except,B1,Y6,S1)	071-669078-00A	AC LINE CORD VDE
77-b(B1,Y6)	071-449078-20	AC LINE CORD BS
77-c(S1)	071-559078-10	AC LINE CORD SAA

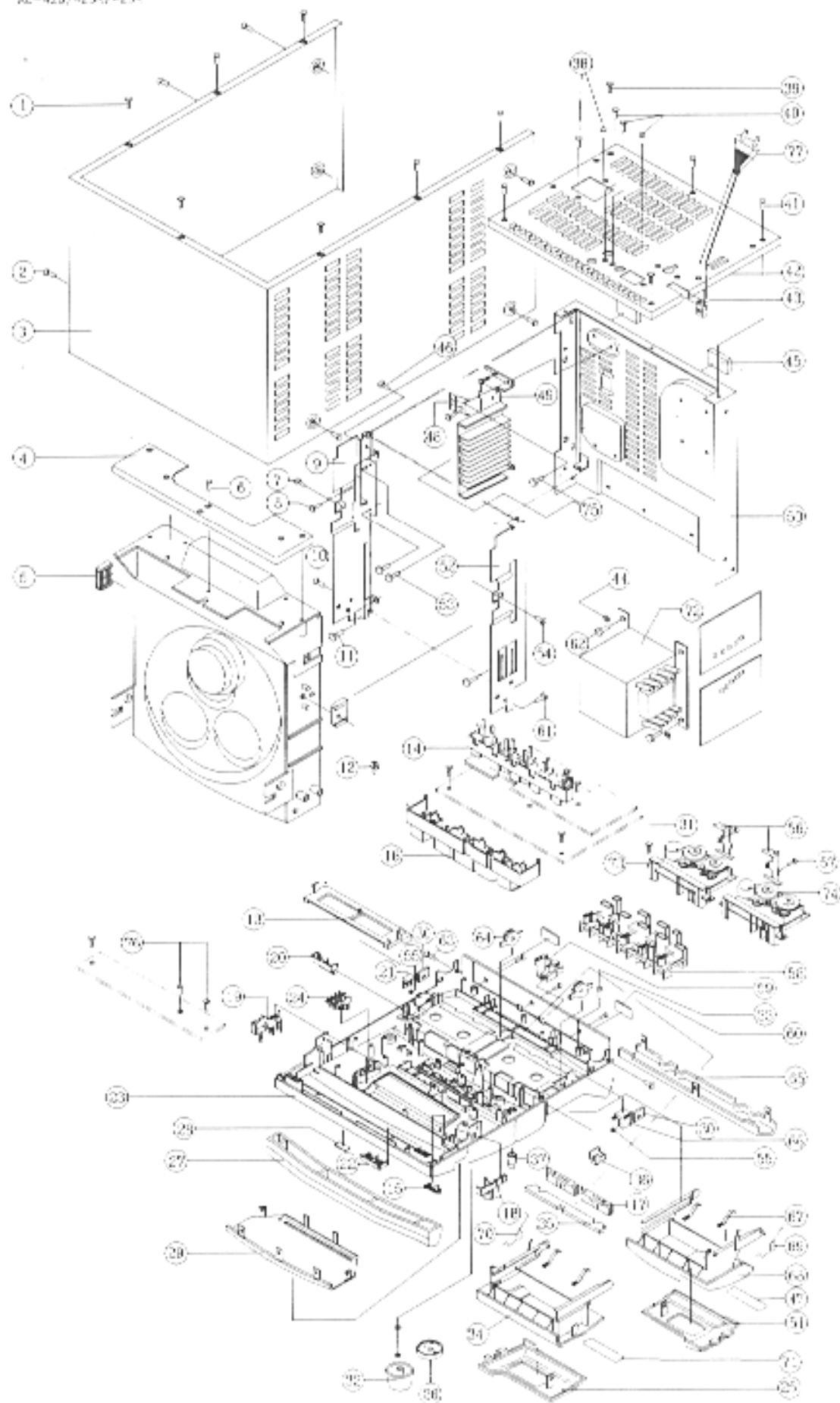

10. AC-620/623R/625K

REF. NO.	PARTS NO.	DESCRIPTION
1	606A301208-00	TAPPING SCREW P TYPE BID H 3X1.25PX8MM
2	606A301208-00	TAPPING SCREW P TYPE BID H 3X1.25PX8MM
3	402-385002-02	MAIN COVER SILVER
4	495-385027-01	REAR CABINET SUB
5	248-385001-01R	MECH SPACER BLACK HI-PS
6	619-300208-00	TAPPING SCREW P TYPE BID H 3X8MM BLACK
7	619-300208-00	TAPPING SCREW P TYPE BID H 3X8MM BLACK
8	619-300208-00	TAPPING SCREW P TYPE BID H 3X8MM BLACK
9	428-385001-01	CD BRACKET 'L'
10	619-300208-00	TAPPING SCREW P TYPE BID H 3X8MM BLACK
11	619-300208-00	TAPPING SCREW P TYPE BID H 3X8MM BLACK
12	292-AA0302-01S	DOBLY BUTTON
13	229-AA0301-01S	FLD BRACKET HI-PS
14	291-AA0302-01S	FUNCTION BUTTON ABS
15	291-AA0303-01S	BALANCE BUTTON GRAY
16	291-AA0306-02Z	OP BUTTON (AC-620)
17	250-AA0301-01S	LAMP HOLDER WHITE ABS
18	292-AA0301-01S	REC BUTTON RED (P-96014) ABS
19	211-AA0502-01S	CASS DOOR PLATE (R)-B BLACK
20	291-AA0305-01S	POWER BUTTON DARK GREY (P-92008) W/MET GREY(T-96008HB) SP. SILK'S RED(S-88011) LETT. ABS
21	229-AA0314-01Z	LATCH BRACKET(L) POM
22	291-AA0301-01S	DISC BUTTON DARK GREY
23-a(AC-620)	200-AA0513-01R	FRONT CABINET HI-PS
23-b(AC-623R)	200-AA0513-02R	FRONT CABINET HI-PS
23-c(AC-625K)	200-AA0514-01R	FRONT CABINET HI-PS
24	275-AA0301-01S	TIMER BUTTON DARK GREY (P-92008) ABS
25	261-AA0301-01K	CASS DOOR LENS (L) SMOKE
26	291-AA0501-01S	CH BUTTON DARK GREY (P-92008) ABS
27	219-AA0311-01R	CD DOOR HI-PS
28	286-385001-02S	NAME PLATE 'AKAI'
29	263-AA0301-02K	DISPLAY LENS AS
30	292-AA0501-01S	ON/OFF BUTTON DARK GREY
31	619-300210-00	TAPPING SCREW P TYPE BID H 3X10MM BLACK
32	273-AA0301-01S	VOLUME KNOB ABS
33	619-300210-00	TAPING SCREW P TYPE BID H 3X10MM BLACK
34	211-AA0301-01S	CASS DOOR (L) HI-PS
35	418-AA0301-01	OVERLAY CLEAR SILK'S WHITE(S-96001) COLOR PVC
36	273-AA0302-01S	VOLUME RING DARK GREY (P-92008) W/PLATTING ABS
37	273-AA0303-01S	MIC KNOB DARK GREY ABS
38	606A301208-00	TAPINET SCREW TYPE BID H 3X1.25PX8MM
39	606A301208-00	TAPINET SCREW P TYPE BID H 3X1.25PX8MM
40	614-300208-00	SELF-TAPPING SCREW B/T 3X8MM BLACK
41	606A301208-00	TAPINET SCREW P TYPE BID H 3X1.25PX3MM
42-a(AC-620 E/B)	495-AA0305-01	PANEL REAR
42-b(AC-620 S)	495-AA0305-02	PANEL REAR
42-c(AC-623R(E))	495-AA0305-03	PANEL REAR
42-d(AC-620 U5,Y6)	495-AA0306-01	PANEL REAR
42-e(AC-620 UB,Y7)	495-AA0306-02	PANEL REAR
43	650-381301-01	CORD BUSHING
44	663-076040-10S	SPRING WASHER 7.6X4X1MM THK SIL CMT
45	330-385002-01	REAR CUSHION FOOT
46	619-300208-00	TAPPING SCREW P TYPE BID H 3X8MM BLACK

47	211-AA0501-01S	CASS DOOR PLATE (L)-B BLACK
48	428-AA0501-01	HOLDER BKT TR-4
49	481-AA0501-01	HEAT SINK 620
50	493-385021-01	METAL BOTTOM CAB 0.8MM
51	261-AA0302-01K	CASS DOOR LENS (R) SMOKE
52	428-385002-01	CD BRACKET 'R'
53	619-300208-00	TAPPING SCREW P TYPE BID H 3X8MM BLACK
54	619-300208-00	TAPPING SCREW P TYPE BID H 3X8MM BLACK
55	477-385011-01	LATCH PUSH SPRING
56	483-AA0301-01	SHIELD HEAD
57	604-264501-00A	TAPPING SCREW C TYPE BID H 2.6X5MM
58	299-AA0312-01S	LID BRACKET WHITE TX-3 ABS
59	229-AA0303-01S	LID BRACKET BLACK ABS
60	330-385001-01	FRONT CUSHION FOOT
61	619-300208-00	TAPPING SCREW P TYPE BID H 3X8MM BLACK
62	602-407008-60A	TAPPING SCREW P TYPE WASHER H 4X8MM
63	619-300212-00	TAPING SCREW P TYPE BID H 3X12MM BLACK
64	703-385002-01	DAMPER DA-60WW (105) ASSEMBLY
65	263-AA0303-01K	DECK DIR LENS AS
66	229-AA0315-01Z	LATCH BRACKET(R) POM
67	263-AA0501-02K	PROG DISPLAY LENS GREY SMOKE (P-96011)AS
68	470-AA0321-01	CASS DOOR SPRING SHEET
69	211-AA0302-01S	CASS DOOR (R) HI-PS
70	471-AA0302-01	CASS DOOR SPRING WIRE (R)
71	471-AA0301-01	CASS DOOR SPRING WIRE (L)
72	229-AA0501-01S	PRO LED BRACKET WHITE ABS
73-a(AC-620/623R)	001-873855-42	POWER TRANSFORMER C1050-E
73-b(AC-625K)	001-873855-02	POWER TRANSFORMER C1050-U
74	741-495300-09	LOGICAL CONTROL DECK MECHA GT-E5300 (P/B)
75	741-495600-09	LOGICAL CONTROL DECK MECHA GT-E5600 (R/P)
76	418-AA0501-01S	OVERLAY CLEAR SILK'S MILKY WHITE COLOR PVC
77	606A301208-00	TAPPING SCREW P TYPE BID H 3X1.25PX8MM
78	619-300210-00	TAPPING SCREW P TYPE BID H 3X10MM BLACK
79	291-AA0304-01S	BASS BUTTON MILKY WHITE (CL-301) ABS
80-a(except,B1,Y6,S1)	071-669078-00A	AC LINE CORD VDE
80-b(B1,Y6)	071-449078-20	AC LINE CORD BS
80-c(S1)	071-559078-10	AC LINE CORD SAA
81	229-385016-01Z	LATCH BRACKET BLACK POM

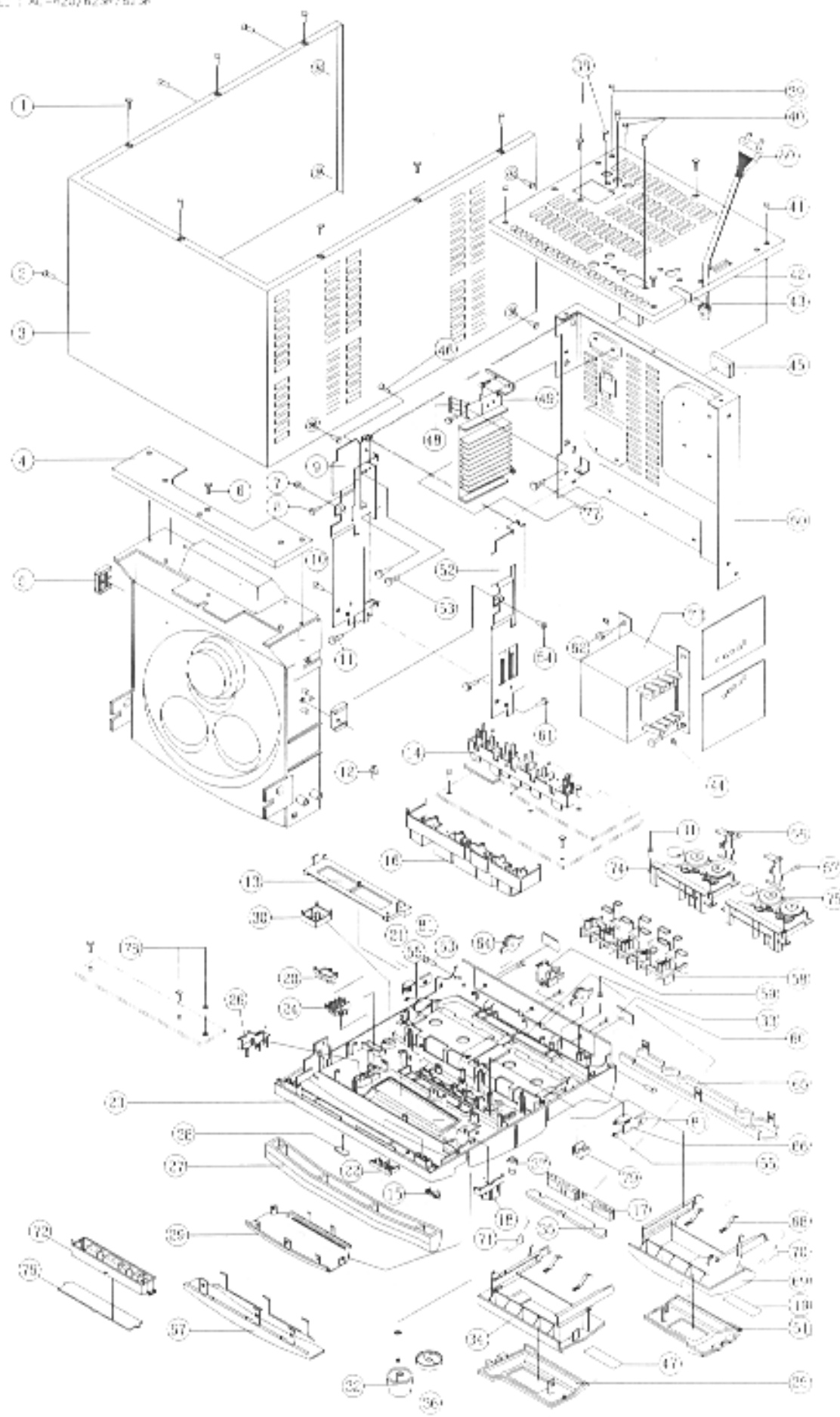

11. SPEAKER SYSTEM (SR-425)

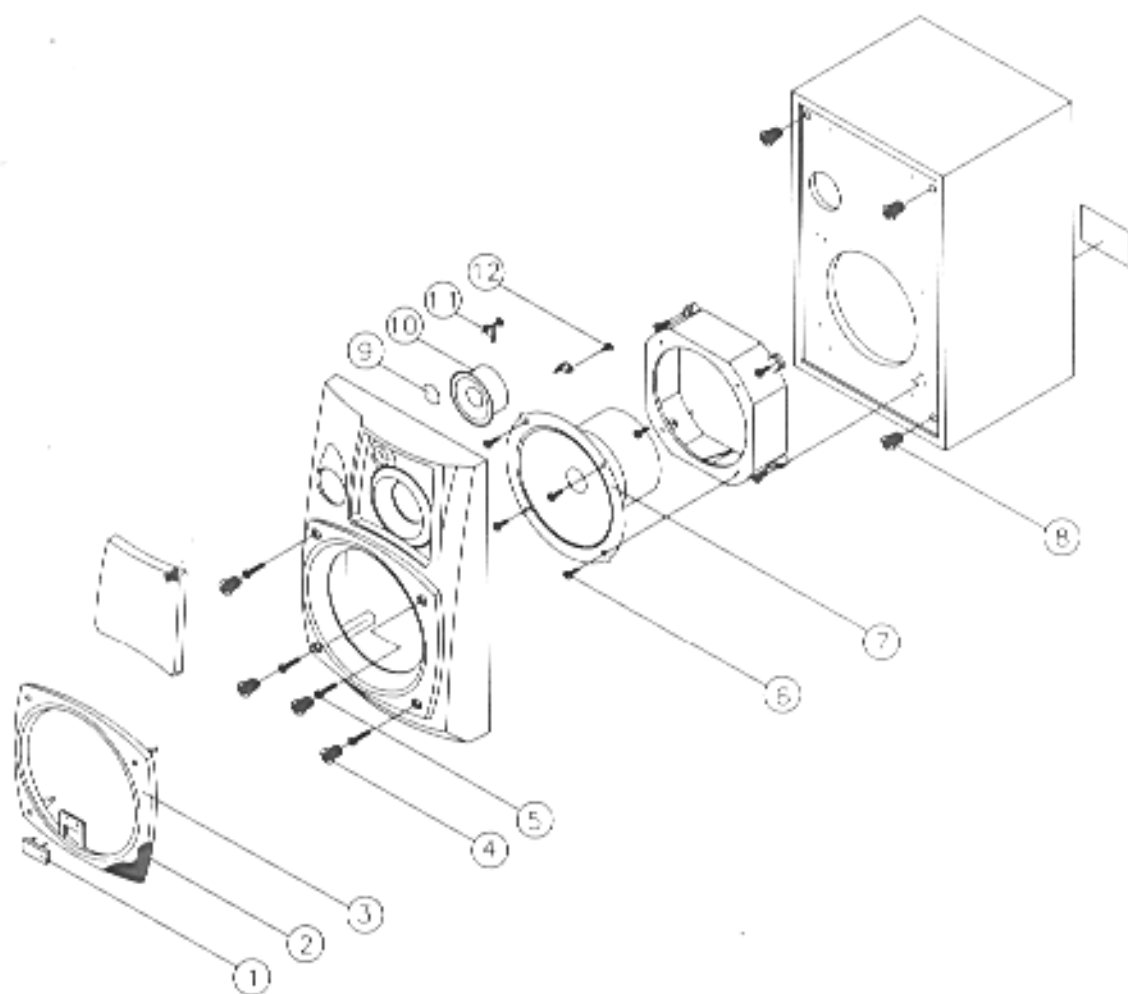

REF. NO	PART NO	DESCRIPTION
1	286-385002-01S	NAME PLATE FOR AKAI
2	583-051501-01	SPEAKER CLOTH
3	239-051501-01R	FRAME NET (R)
4	259-050201-01Z	CUSHION FOR SPEAKER BOX BLK S B R
5	610-350220-10	SELF-TAPPING SCREW R/T 3.5X20MM
6	614-400216-30	SELF-TAPPING SCREW R/T 4.0X16MM BLACK
7	066-953254-WT	WOOFER SPEAKER
8	259-381301-01	CUSHION
9	070-100027-02Z	27MM PIEZO
10	066-283220-WT	MIDRANGE SPEAKER
11	462-333202-01	SPEAKER CLIP
12	612-300210-10	SELF-TAPPING SCREW 3X10MM

12. REMOTE EXPLODED DIAGRAM AND PARTS LIST

RC-S520

REF. NO

*

*

2

3

4

5

6

7

8

9

10

PART NO

790-010301-01

411-010301-01

201-010302-01S

334-010311-01

090-010302-03

473-010311-01

472-010311-01

203-010311-01S

610-260206-10

474-010101-01

210-010301-01S

DESCRIPTION

REMOTE CONTROL HANDSET RC-S520

REMOTE NAME PLATE

REMOTE CAB TOP

REMOTE CONTACTIVE RUBBER (46 KEYS)

PCB REMOTE BOARD

BATT CONTACT SPRING SHEET-VE

BAT CONTACT PLATE +VE

REMOTE CABINET BOTTOM

SELF-TAPPING SCREW K/T 2.6X6

BAT CONTACT SPRING WIRE +/-VE

REMOTE BATTERY COVER

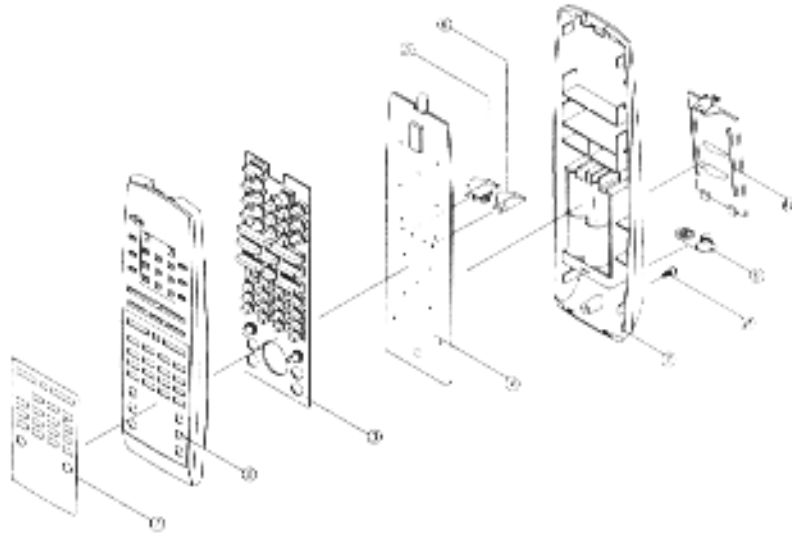

RC-S720

REF. NO

*

1

2

3

4

5

6

7

8

9

10

PART NO

790-010302-01

411-010302-01

201-010301-02S

334-010312-01

090-010302-03

473-010311-01

472-010311-01

203-010311-01S

610-260206-10

474-010101-01

210-010301-01S

DESCRIPTION

REMOTE CONTROL HANDSET RC-S720

REMOTE NAME PLATE

REMOTE CAB TOP

REMOTE CONTACTIVE RUBBER (46 KEYS)

PCB REMOTE BOARD

BATT CONTACT SPRING SHEET-VE

BAT CONTACT PLATE +VE

REMOTE CABINET BOTTOM

SELF-TAPPING SCREW K/T 2.6X6

BAT CONTACT SPRING WIRE +/-VE

REMOTE BATTERY COVER

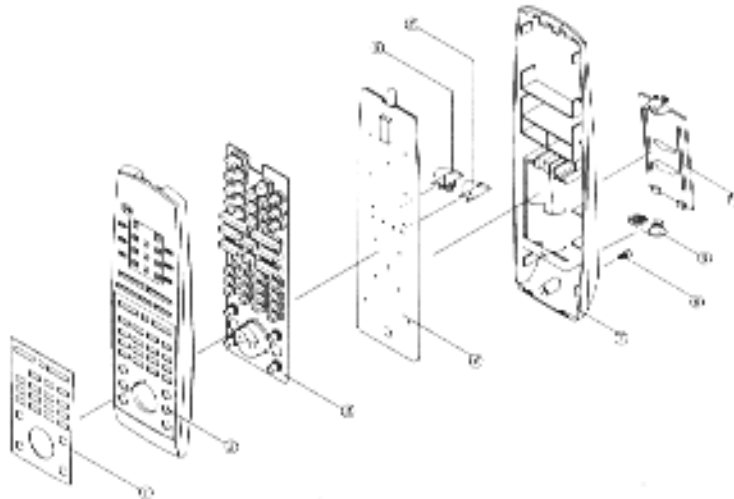

XII. ABBREVIATIONS

TUNER

ABBREVIATION	EXPLANATION	ABBREVIATION	EXPLANATION
AFC	Auto Frequency Control	MEMO	MEMOry
AGC	Auto Gain Control	MI-COM	Micro-COMputer
ALC	Auto Level Control	MIN	MINimum
AM	Amplitude Modulation	MX	MIXing
AMP	AMPLifier	MPX	MultiPleX
ANT	ANTenna	MW	Medium Wave(frequency)
BATT	BATTery	NC	No Connection
BLK	BLock	NFB	Negative Feed Back
BUFF	BuFFer	OSC	OSCillator
COMP	COMParator	PCB	Printed Circuit Board
DET	DETECT(DETector)	PLL	Phase Locked Loop
FLD	FLuorescent Display	Q.D	Quadrature Detector
FM	Frequency Modulation	Rch	Right channel
FREQ	FREQuency	REF	REFerence
GND	GrouND	REG	REGulator
H	High	RF	Radio Frequency
HPF	High Pass Filter	SEG	SEGment
IF	Intermediate Frequency	SELE	SELEctor
IHF	Institute of High Fidelity	SENS	SENSitivity
IND	INDicator	SIG	SIGnal
IO	In/Out	SN	Signal to Noise Ratio
JW	Jumper Wire	SSG	Standard Signal Generator
L	Low	STD	STanDard
LCD	Liquid Crystal Display	SW	Switch; Short Wave(frequency)
LCH	Left Channel	THD	Total Harmonic Distortion
LED	Light Emitting Diode	TP	Test Point
LPF	Low Pass Filter	VCO	Voltage Controlled Oscillator
LW	Long Wave (Frequency)	VR	Variable Resistor
XTAL	Crystal		

COMPACT DISC

ABBREVIATION	EXPLANATION	ABBREVIATION	EXPLANATION
A-D	Analog to Digital(Converter)	Mb	Mega Bits
ADC	Analog Code Decimal (Converter)	MDA	Motor Drive Amplifier
BCD	Binary Code Decimal	MFM	Modified Frequency Modulation
BPI	Bits Per Inch	MV	Mono-stable Multivibrator
CD	Compact Disc	M2FM	Modified Modified Frequency Modulation
CIRC	Cross Interleaving & Reed Solomon Coding	MOD2	Module 2 (Addition)
CLV	Constant Linear Velocity	MP	Microprocessor
CP	Clock Pulses	MSB	Most Significant Bit
CRCC	Cyclic Redundancy Check Codes	NA	Numerical Aperture
D Level	Decision Level	NRZ	Non Return to Zero
D-A	Digital to Analog(Converter)	NRZ-I	Non Return to Zero Inverted
DAC	Digital to Analog(Converter)	P	Parity Data
DAD	Digital Audio Disc	PAM	Pulse Amplitude Modulation
DEM	Dynamic Element Matching	PCM	Pulse Code Modulation
DPD	Differential Phase Detection	PD	Phase Detector
DSV	Digital sum Value	PE	Phase Encode
EFM	Eight to Fourteen Modulation	PLL	Phase locked Loop
EX-OR	Exclusive OR	PNM	Pulse Number Modulation
FCI	Flux Changes per Inch	PPM	Pulse Phase Modulation
FIR	Finite Impulse Response	PWM	Pulse Width Modulation
FP	Front Pulse	Q	Parity Data
FPG	Front Pulse Gate	R,R1,R2,ect.	Data for Right Channel
F	Frequency of Sampling	RAM	Random Access Memory
GF	Galois Field	RPG	Rear Pulse Gate
H&V(Parity)	Horizontal & Vertical	SCOOP	Self Coupled Optical Pick-up
IIR	Infinite Impulse Response	S&H	Sample & Hold
KB	Kilo Bits	S/N	Signal to Noise Ratio
L,L1,L2,ect.	Data for Left Channel	SSG	Standard Signal Generator
LPF	Low Pass Filter	SYSCON	SYSTEM CONTROL
LSB	Least Significant Bit		

CASSETTE

ABBREVIATION	EXPLANATION	ABBREVIATION	EXPLANATION
AC	Alternating Current	MIN	Minute
A/D	Analog/Digital	MML	Maximum Modulation Level
AF	Auto Fader	MOL	Maximum Output Level
AMP	AMPlifier	MPX	MultiPlex
AR	Anti Recording	NC	Not connected (No Connection)
ATBIAS	Auto Turning BIAS	NFB	Negative Feed Back
ATT	ATTenuator	NORM	NORMAl
BAL	BALance	NR	Noise Reduction
BEFB	and Elimination Filter	OSC	OSCillator (OSCillation)
BSS	Blank Search System	P	Pulse
CAPM	CAPstan Motor	PB	Play Back
CH	CHannel	QMSS	Quick Memory Search System
COMP	COMParator	OR	Quick Reverse
CONT	CONTinuance	RCH	Right CHannel
CRLP	Computer Recording Level Processing	REC	RECord (RECording)
CS	Chip Select	REV	REVERSE
D/A	Digital/Analog	ROT	ROTation
DC	Direct Current	REW	REWind
DET	DETECTOR	SEC	SECOnd
DISCRI	DISCRIminator	SELE	SELEctor
DUB	DUBbing	SENS	SENSitivity
EQ	EQUALizer	SEPP	Single Ended Push Pull
FF or (F.FWD)	Fast Forward	SIG	SIGNAL
FLD	FLUorescent Display	SPECT	SPECTrum
FREQ	FREQUENCY	STD	STANdard
FWD	FORWARD	SW	SWitch
GND	GROUNd	SYSCON	SYSTEM CONTROL
H	High	TP	TEST Point
HPF	High Pass Filter	TRIG	TRIGa
IND	INDicator	VCA	Voltage Control Attenuator
IPLS	Instant Program Location System	VOL	Volume
L	Low	VOLT	VOLTage
LCH	Left Channel	VR	Variable Resistor
LEDLight	Emitting Diode	XTAL	crystal
MEMO	MEMOry	X1	Normal speed
MICOM	MicroCOMputer	X2	Double speed

TX-420/520
(AC-420/428R/426K)
(AC-820/523R/525K)

AKAI

AKAI ELECTRIC CO., LTD.

Printed Date July 1997