

# AKAI SERVICE MANUAL

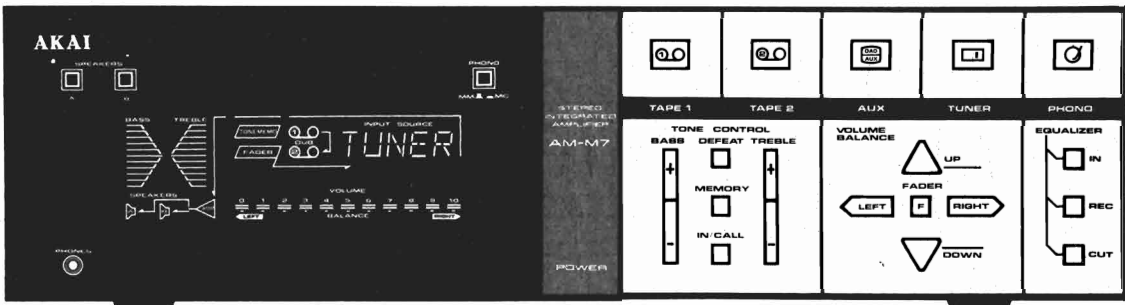
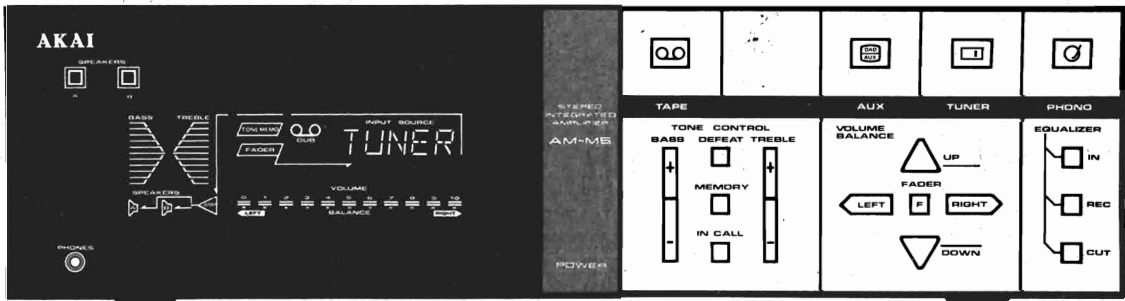
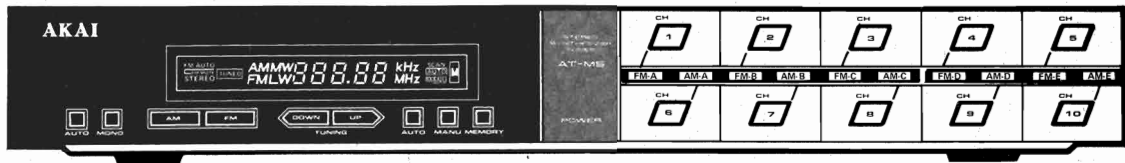

QUARTZ SYNTHESIZER TUNER

MODEL **AT-M5/L**

STEREO INTEGRATED AMPLIFIER

MODEL **AM-M5**

MODEL **AM-M7**

## ABBREVIATIONS FOR SERVICE MANUAL MODEL AT-M5/L, MODEL AM-M5/M7

ABBREVIATION	EXPLANATION	ABBREVIATION	EXPLANATION
AC	Alternating Current	LSI	Large-Scale Integration
AF	Audio Frequency	LW	Long Wave
AFC	Automatic Frequency Control	MANU	MANUal
AGC	Automatic Gain Control	MC	Memory Control
ALC	Automatic Level Control	MIX	MIXer
AM	Amplitude Modulation	MM	Moving Magnet (cartridge)
ANT	ANTenna	M. ME	Memory
APPROX	APPROXimately	MONO	MONOphonic
BCD	Binary Coded Decimal	MPX	MultiPleX
BUF	BUFfer	NF	Negative Feedback
CK	ClocK	OSC	OSCillator
CMOS	Complementary Metal-Oxide Semi-Conductor	RL	ReLay
CPU	Central Processing Unit	PLL	Phase Locked Loop
DET	DETEctor	PSC	PreSCaler
EIAJ	Electronic Industry Association of Japan	RAM	Random Access Memory
EQ	EQualizer	RCH	Right CHannel
FF	Flip-Flop	REG	REGulator
FLD	FLuorescent Display	RF	Radio Frequency
FM	Frequency Modulation	ROM	Read Only Memory
FREQ	FREQuency	SEG	SEGment
GND	GrouND	SENS	SENSitivity
H	High (referring to voltage)	SM	Signal Meter
IF	Intermediate Frequency	SSG	Standard Signal Generator
IHF	Institute of High Fidelity	ST	STereo
IND	INDicator	STO	STOre
INH	INHibit	SW	SWitch
INT	INTerrupt	SYNC	SYNChronize
L	Low (referring to voltage)	THD	Total Harmonic Distortion
LCD	Liquid Crystal Display	VCO	Voltage Controlled Oscillator
LCH	Left CHannel	XT	Crystal Controlled Connection Terminal
LED	Light Emitting Diode	XTAL	CrysTAL
LPF	Low Pass Filter		

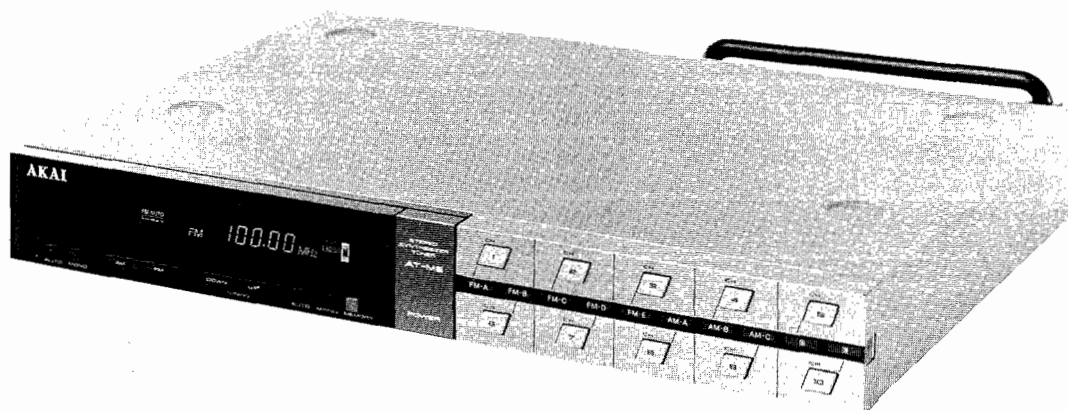

SECTION 1

**SERVICE MANUAL**

**MODEL AT-M5/L**

TABLE OF CONTENTS

I. SPECIFICATIONS .....	4
II. DISMANTLING OF UNIT .....	5
III. CONTROLS .....	6
IV. PRINCIPAL PARTS LOCATION .....	8
V. VOLTAGE CONVERSION .....	9
VI. DESCRIPTION OF CIRCUIT .....	10
1. FM SECTION BLOCK DIAGRAM .....	10
2. AM SECTION BLOCK DIAGRAM .....	10
3. THE PERIPHERAL CIRCUIT OF MI-COM AND FL DISPLAY .....	11
4. FM PLL SYNTHESIZER .....	15
5. AM TUNING AND AM VCO CIRCUIT .....	16
6. AUTO TUNING .....	17
7. CPU IC4 BACK-UP .....	17
8. MUTE CIRCUIT .....	18
9. MODE SW .....	18
VII. ELECTRICAL ADJUSTMENT .....	19
VIII. CLASSIFICATION OF VARIOUS P.C BOARDS .....	22
1. P.C BOARD TITLES AND IDENTIFICATION NUMBERS .....	22
2. COMPOSITION OF VARIOUS P.C BOARDS .....	23

For basic adjustments, measuring methods, and operating principles, refer to GENERAL TECHNICAL MANUAL.

# I . SPECIFICATIONS

## FM TUNER SECTION

TUNING FREQUENCY RANGE	J Model: 76MHz to 90MHz Other Models: 87.4MHz to 108.1MHz
USABLE SENSITIVITY (IHF)	11.2dBf
QUIETING SENSITIVITY (S/N=50dB) MONO/ST	16.2/37.2dBf
CAPTURE RATIO	1.5dB
SELECTIVITY (400kHz)	60dB
IMAGE REJECTION	85dB
IF REJECTION	90dB
SPURIOUS REJECTION	90dB
AM SUPPRESSION	60dB
SUB CARRIER SUPPRESSION	60dB
S/N RATIO MONO/ST	75/65dB
T.H.D (MONO/ST)	0.08/0.3%
STEREO SEPARATION (1kHz)	45dB

## AM TUNER SECTION

TUNING FREQUENCY RANGE	MW 530 to 1610kHz (USA & Canada) 522 to 1611kHz (Others)	LW 153 to 360kHz
USABLE SENSITIVITY (LOOP)	300 $\mu$ V/m	800 $\mu$ V/m
SELECTIVITY	25dB	30dB
IMAGE REJECTION	40dB	45dB
IF REJECTION	55dB	55dB
S/N RATIO	40dB	35dB
T.H.D	1%	—
MEMORY BACK-UP	20 Days	

## OUTPUT SECTION

OUTPUT LEVEL	
FM (100% MOD)	700mV
AM (30% MOD)	250mV
OUTPUT IMPEDANCE	1.5kohms
POWER REQUIREMENTS	100V, 50/60Hz for Japan 120V, 60Hz for USA & Canada 220V, 50Hz for Europe except for UK 240V, 50Hz for UK & Australia 110-120V/220-240V, 50/60Hz Switchable for other countries
POWER CONSUMPTION	10W (All Models)
DIMENSIONS	350 (W) x 50 (H) x 274 (D)mm (13.8 x 2 x 10.8 inches)
WEIGHT	2.5kg (5.5 lbs)

\* For improvement purposes, specifications and design are subject to change without notice.

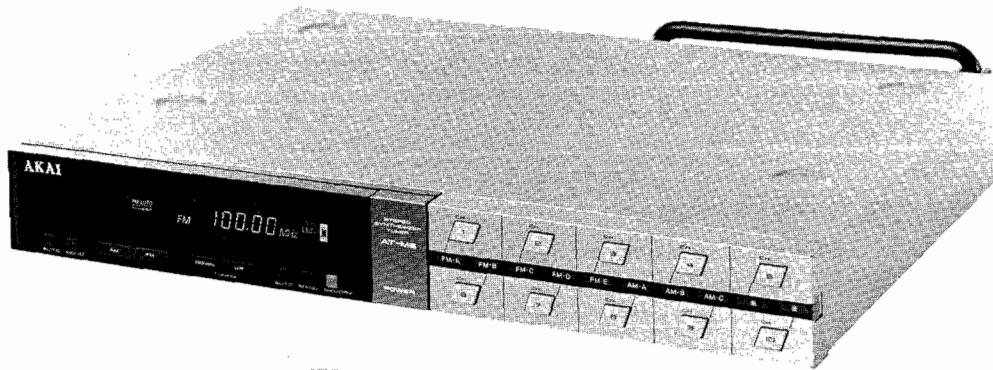

AT-M5/L

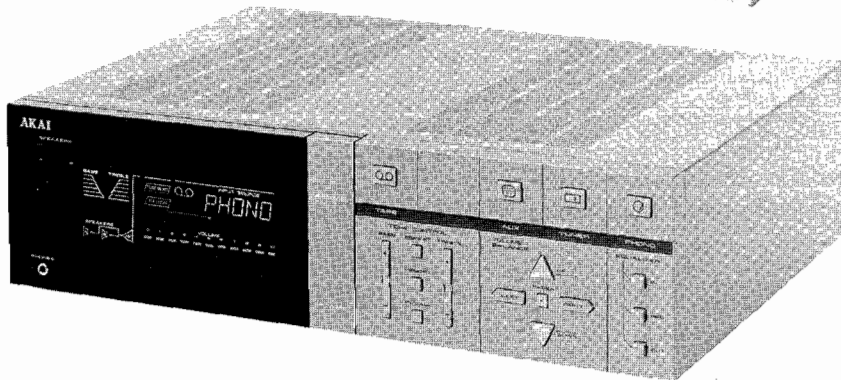

AM-M5



AM-M7

**QUARTZ SYNTHESIZER TUNER  
MODEL AT-M5/L**

**STEREO INTEGRATED AMPLIFIER  
AM-M5  
MODEL AM-M7**

SECTION 1	MODEL AT-M5/L SERVICE MANUAL .....	3
SECTION 2	CIRCUIT OPERATION DESCRIPTION .....	27
SECTION 3	MODEL AM-M5/M7 SERVICE MANUAL .....	35
SECTION 4	PARTS LIST .....	61
SECTION 5	SCHEMATIC DIAGRAM .....	77

# SAFETY INSTRUCTIONS

---

## SAFETY CHECK AFTER SERVICING

Confirm the specified insulation resistance between power cord plug prongs and externally exposed parts of the set is greater than 10 Mohms, but for equipment with external antenna terminals (tuner, receiver, etc.) and is intended for [C] or [A], specified insulation resistance should be more than 2.2 Mohms (ground terminals, microphone jacks, headphone jacks, line-in-out jacks etc.)

## PRECAUTIONS DURING SERVICING

1. Parts identified by the  $\triangle$  symbol parts are critical for safety.  
Replace only with parts number specified.
2. In addition to safety, other parts and assemblies are specified for conformance with such regulations as those applying to spurious radiation. These must also be replaced only with specified replacements.  
Examples: RF converters, tuner units, antenna selector switches, RF cables, noise blocking capacitors, noise blocking filters, etc.
3. Use specified internal wiring. Note especially:
  - 1) Wires covered with PVC tubing
  - 2) Double insulated wires
  - 3) High voltage leads
4. Use specified insulating materials for hazardous live parts. Note especially:
  - 1) Insulation Tape
  - 2) PVC tubing
  - 3) Spacers (Insulating Barriers)
  - 4) Insulation sheets for transistors
  - 5) Plastic screws for fixing microswitch (especially in turntable)
5. When replacing AC primary side components (transformers, power cords, noise blocking capacitors, etc.), wrap ends of wires securely about the terminals before soldering.

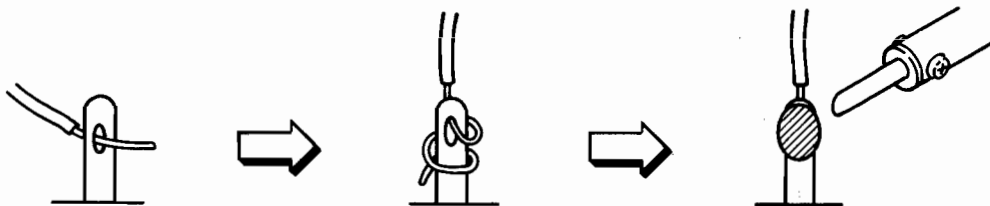

6. Observe that wires do not contact heat producing parts (heatsinks, oxide metal film resistors, fusible resistors, etc.).
7. Check that replaced wires do not contact sharp edged or pointed parts.
8. Also check areas surrounding repaired locations.
9. Use care that foreign objects (screws, solder droplets, etc.) do not remain inside the set.

## II. DISMANTLING OF UNIT

In case of trouble, etc. necessitating dismantling, please dismantle in the order shown in the photographs. Reassemble in reverse order.

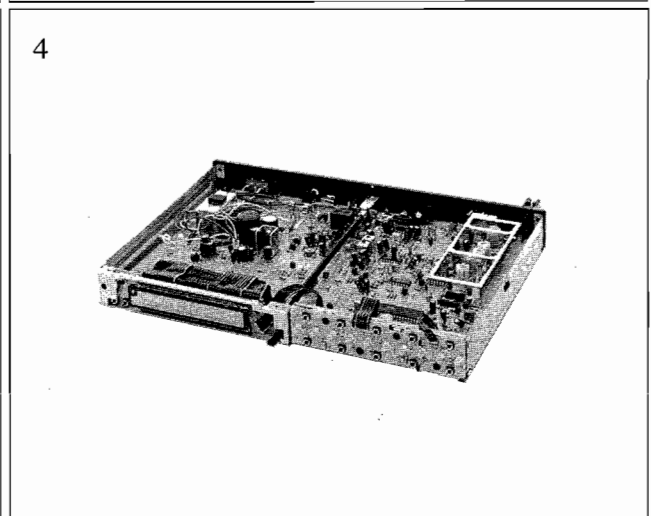
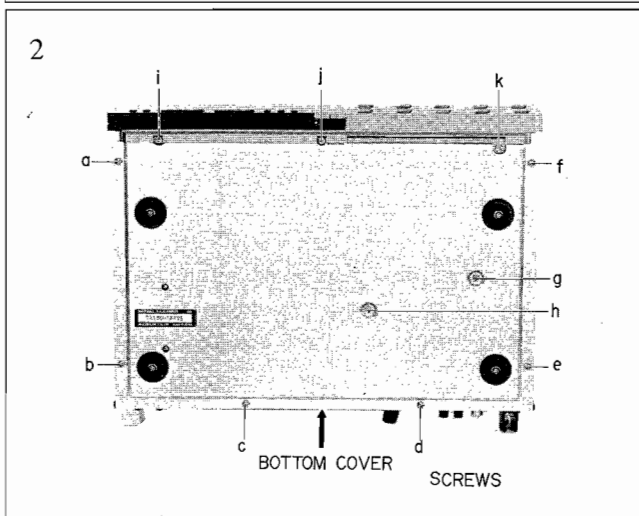
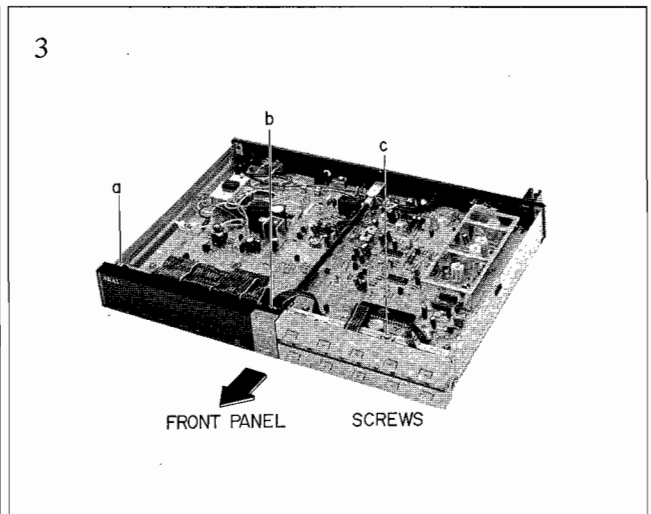
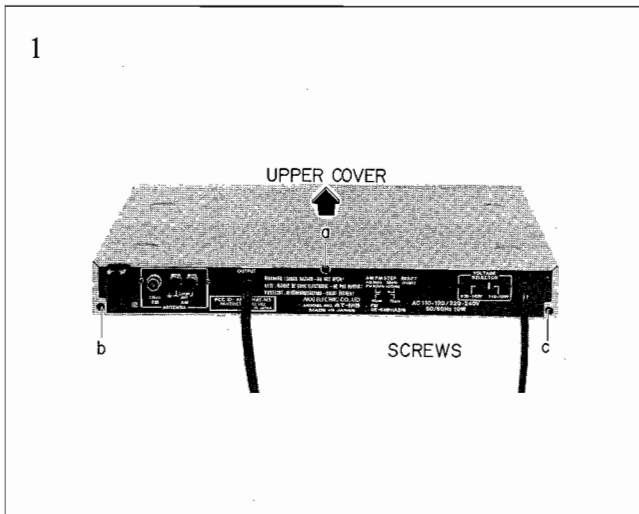

### III. CONTROLS

#### 3-1. CONTROLS

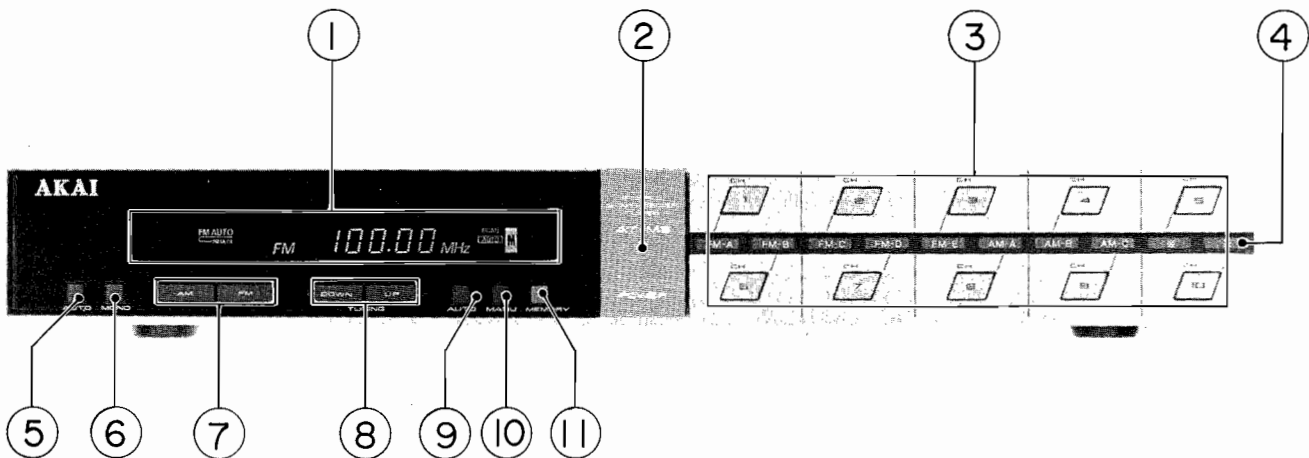

Fig. 3-1

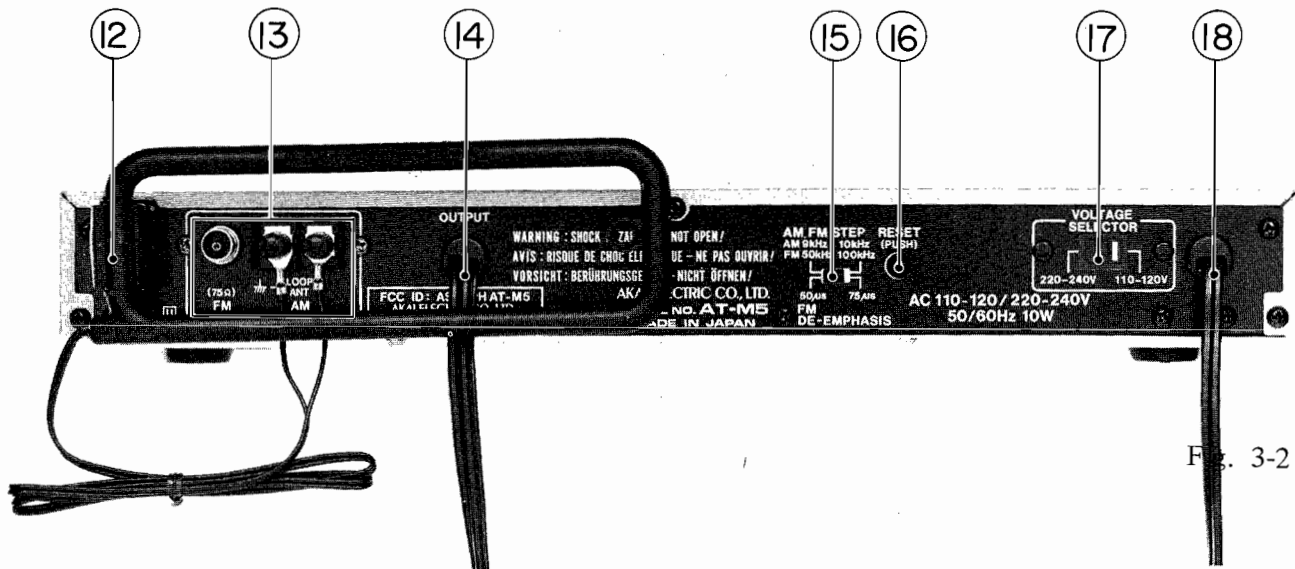

Fig. 3-2

- |  |   |
|--|---|
| <ol style="list-style-type: none"> <li>1. FL DISPLAY<br/>THE INDICATOR OF : FM AUTO; FM MUTE, STEREO, TUNED, FM, AM, MW, LW, kHz, MHz, SCAN (AUTO/MANU), &amp; M (MEMORY).</li> <li>2. POWER SWITCH</li> <li>3. PRESET STATION BUTTONS (CH1~CH10)</li> <li>4. PRESET STATIONS INDICATOR</li> <li>5. AUTO BUTTON : FM AUTO (FM MUTE)</li> <li>6. MONO BUTTON : FM MONO</li> <li>7. AM/FM SELECTOR<br/>(FM/MW/LW SELECTOR FOR MODEL AT-M5L)</li> <li>8. TUNING UP/DOWN BUTTON</li> </ol> | <ol style="list-style-type: none"> <li>9. AUTO BUTTON : AUTOMATIC SCAN TUNING</li> <li>10. MANU BUTTON : MANUAL SCAN TUNING</li> <li>11. MEMORY BUTTON : FOR PRESET STATIONS</li> <li>12. AM LOOP ANTENNA</li> <li>13. ANTENNA TERMINALS FOR FM (75Ω) &amp; AM LOOP ANTENNA</li> <li>14. OUTPUT CORD</li> <li>15. AM FM STEP &amp; FM DE-EMPHASIS SELECTOR (U MODEL ONLY)</li> <li>16. RESET BUTTON</li> <li>17. VOLTAGE SELECTOR (U MODEL ONLY)</li> <li>18. POWER CORD</li> </ol> |
|--|---|



### 3.2 RESET BUTTON AND AM.FM STEP/FM DE-EMPHASIS SELECTOR (REFER TO Fig. 2,3 & 4)

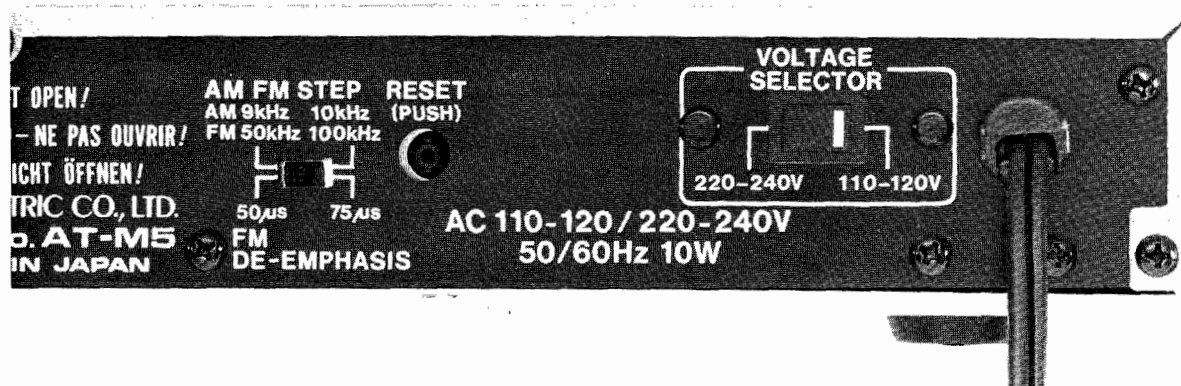

Fig. 3-3 Rear View (U Model)

#### 3-2-1. RESET BUTTON

At the back of the AKAI AT-M5/L, there is a RESET button which sets the micro-computer inside the AKAI AT-M5/L to the initial modes when it is depressed. Depress this button should the following occur when the backup power for the micro-computer's memory is insufficiently charged.



Fig. 3-4

1) The AKAI AT-M5/L will not function when a button is depressed.

2) A frequency is not properly displayed.

\* If it is difficult to depress the RESET button, use a screwdriver or a ball point pen.

When the RESET button is depressed while the AKAI AT-M5/L is turned on, it will go into the following initial modes:

3) The AKAI AT-M5/L will go into FM reception.

4) The frequency will be set to 76MHz. (J model).  
87.4 MHz (Other models)

5) The tuning mode will be set to manual.

6) All the preset stations will be canceled.

After depressing the RESET button, you must reset the preset stations again.

#### 3-2-2. AM FM STEP/FM DE-EMPHASIS SELECTOR (Not on some models)

Use this selector to set the frequency scanning steps and to de-emphasize the Dolbyized FM signal in amount equal to the emphasis made at the broadcasting station. Set this selector according to your area.

Attention

After setting this selector, turn ON the AKAI AT-M5/L and then depress the RESET button.

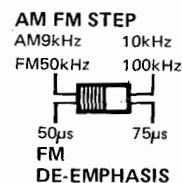

Fig. 3-5

# IV. PRINCIPAL PARTS LOCATION

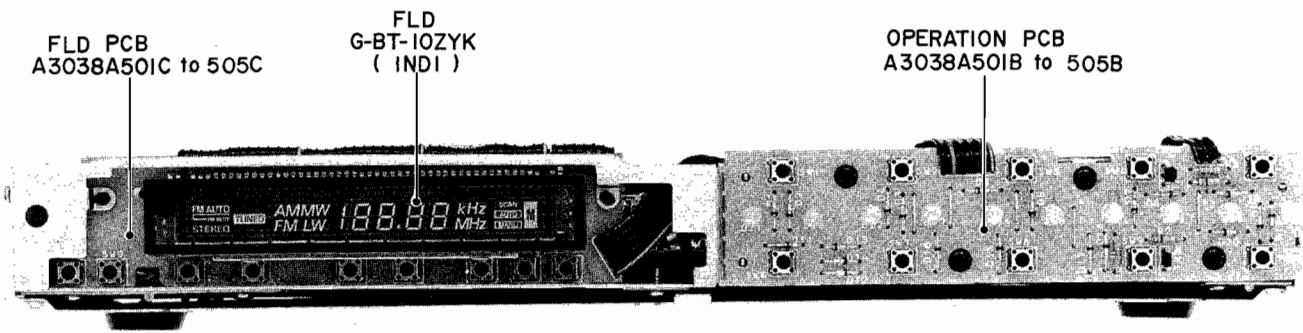

Fig. 4-1

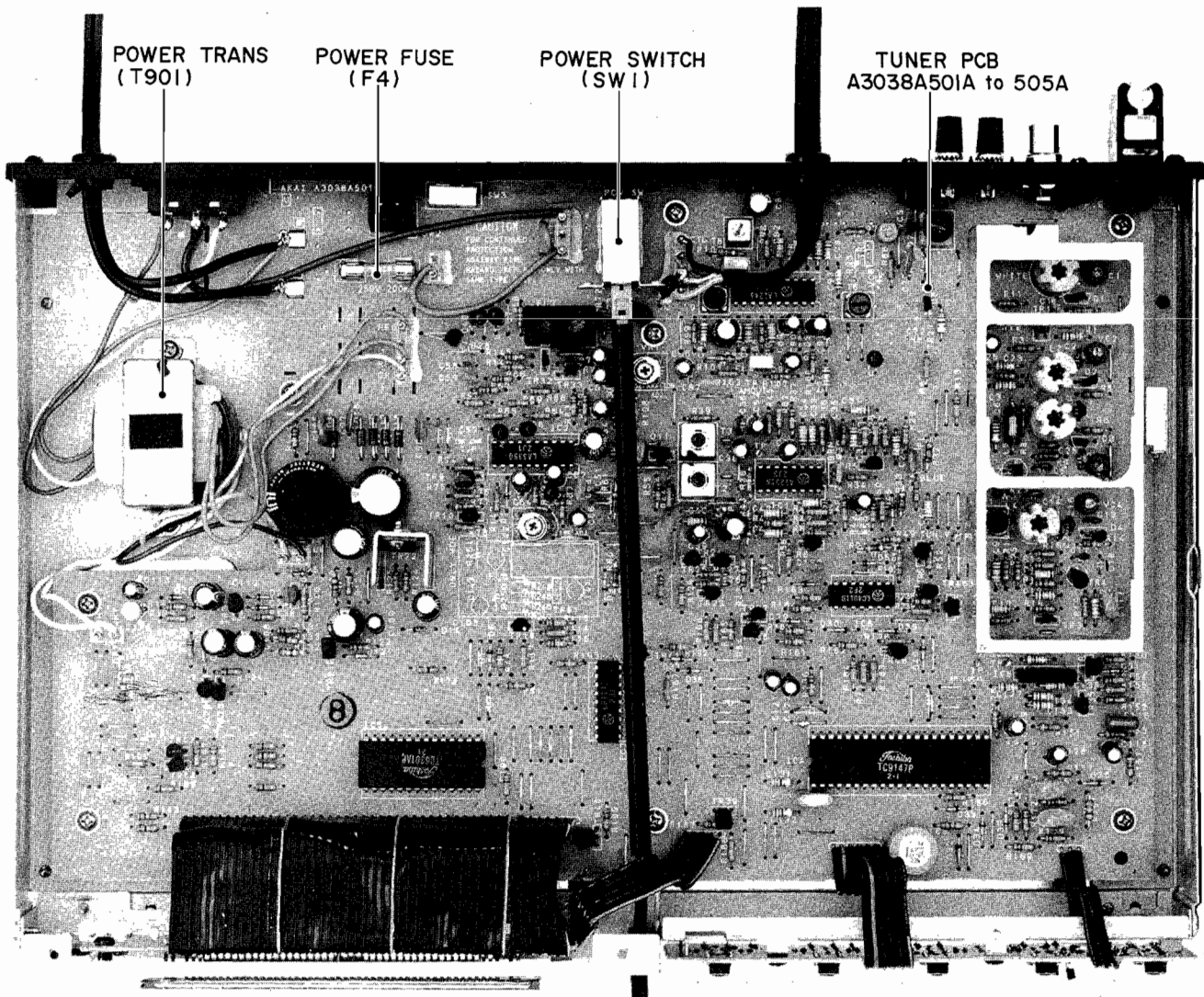

Fig. 4-2

## V. VOLTAGE CONVERSION

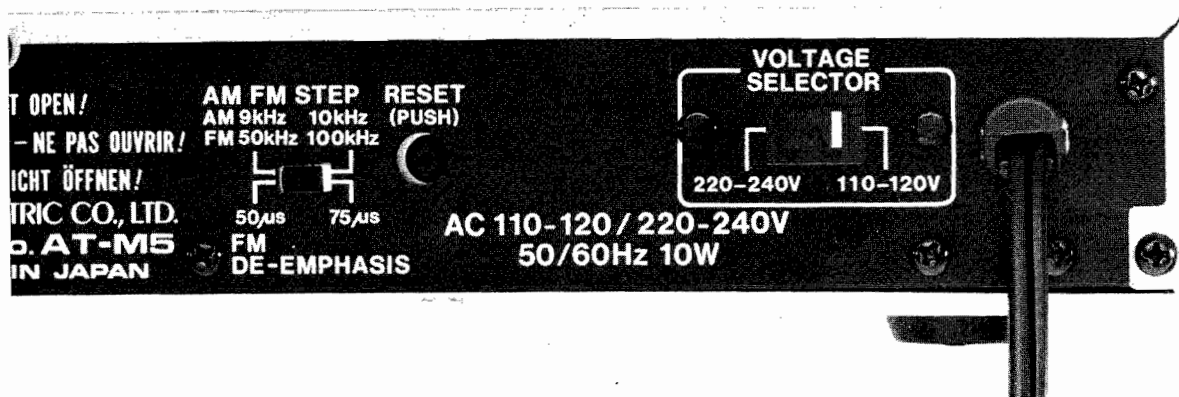

Fig. 5-1 Rear View (U Model)

Models for Japan, Canada, USA, UK and Australia are not equipped with this facility. Each machine is preset at the factory according to destination.

However, if voltage conversion is necessary, it is accomplished as follows:

- (1) Disconnect the power cord.
- (2) Set the voltage selector located on the rear panel to the proper position with a screwdriver.

# VI. DESCRIPTION OF CIRCUITS

## 6-1. FM SECTION BLOCK DIAGRAM

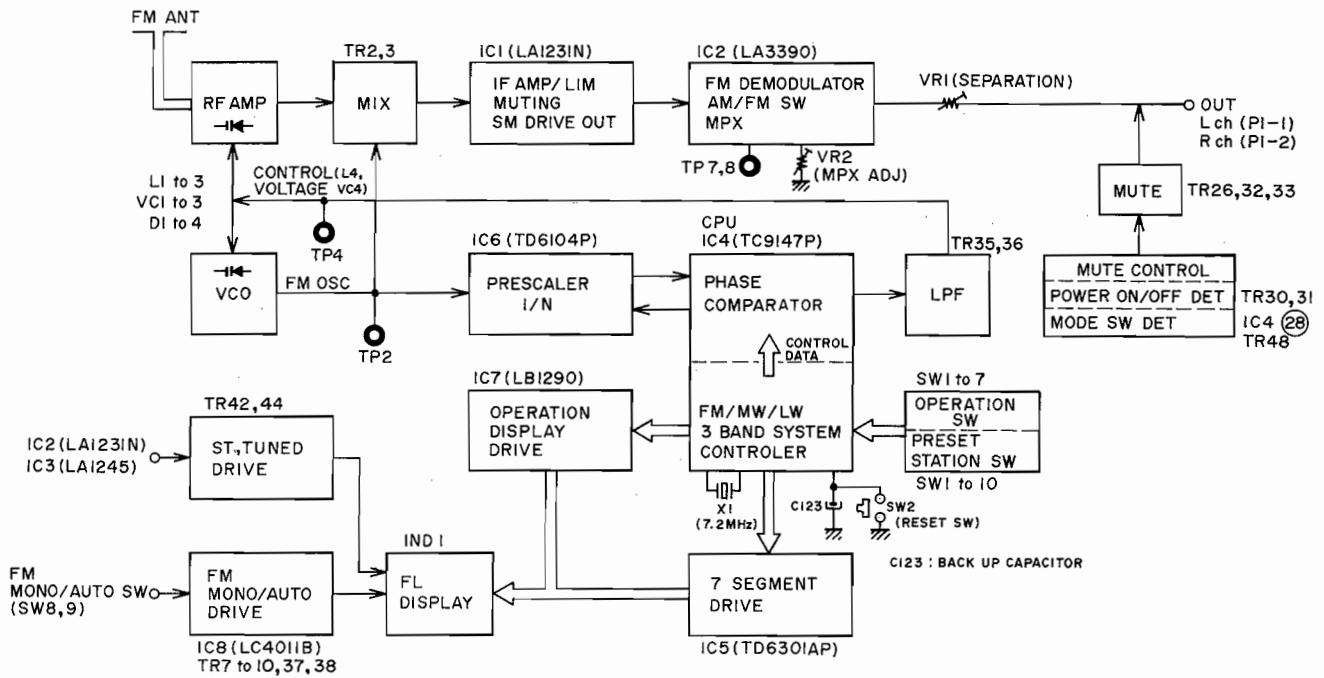

Fig. 6-1

## 6-2. AM SECTION BLOCK DIAGRAM

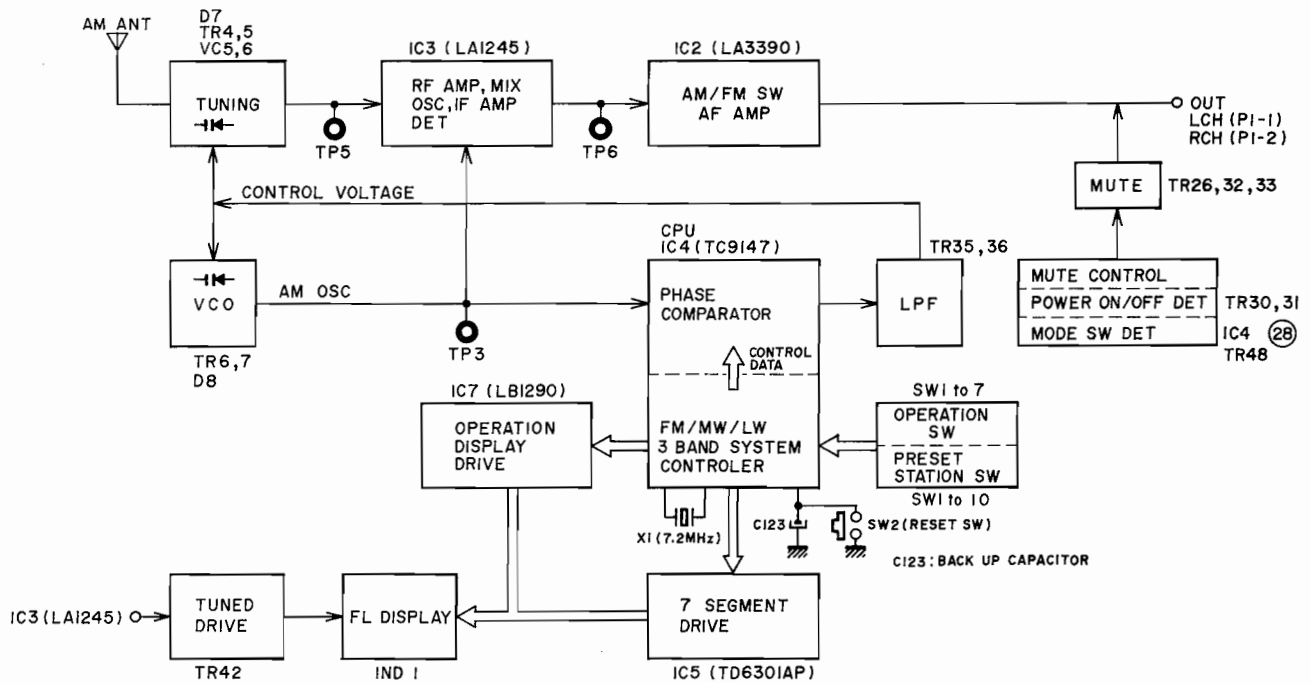

Fig. 6-2

6-3. THE PERIPHERAL CIRCUIT OF CPU (IC4TC9147P) AND FL DISPLAY (IND1 9-BT-10ZYK)

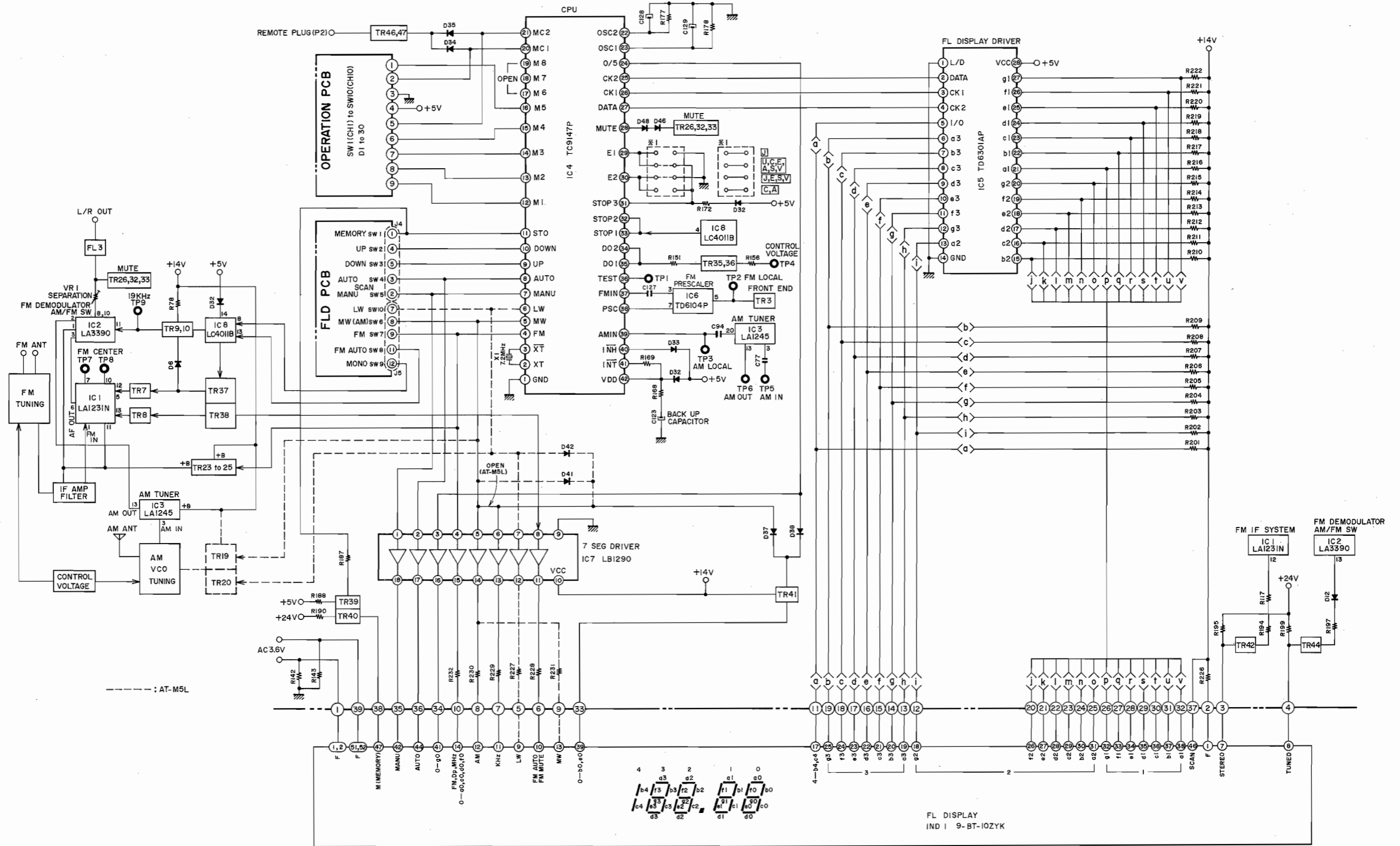
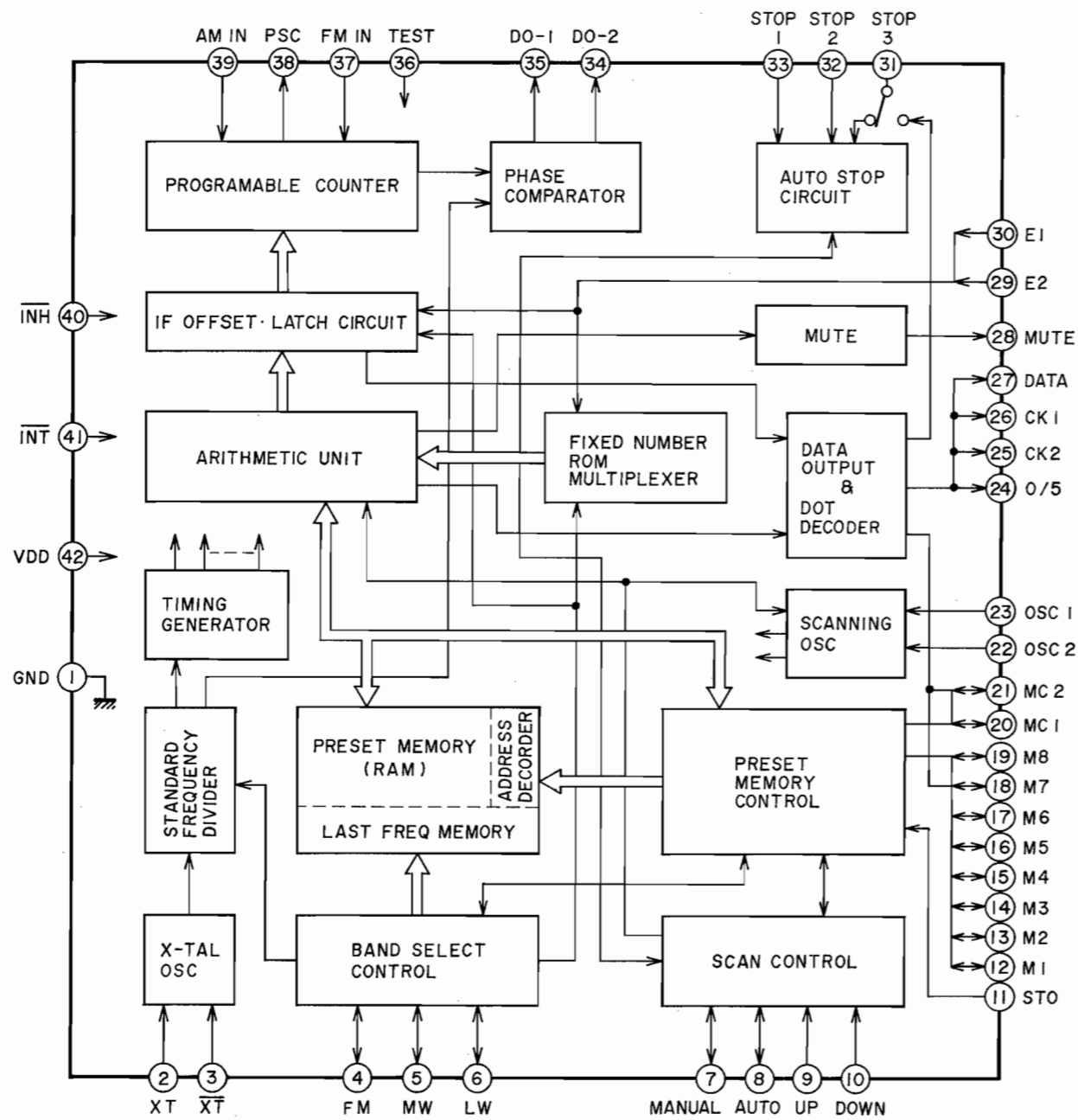
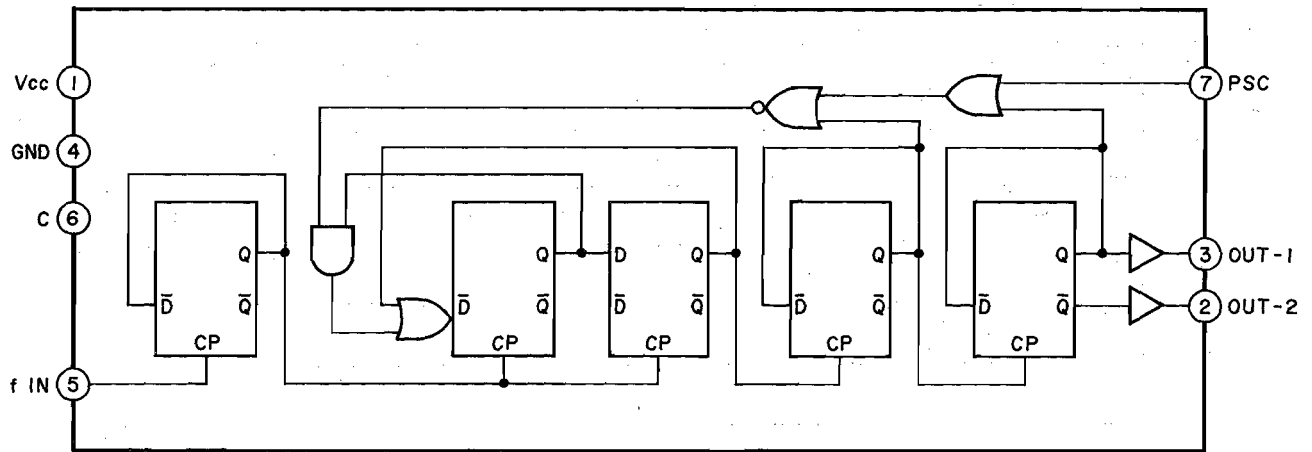

Fig. 6-3



Pin No.	Symbol	Meaning	Function
1	GND	Ground	
2	XT	X-TAL OSC Terminals	Input Terminal of Standard Frequency OSC (X-TAL: 7.2MHz)
3	$\overline{XT}$		
4	FM	FM Band Designation Input	Band Selector
5	MW	MW Band Designation Input	
6	LW	LW Band Designation Input	
7	Manual	Manual Tuning Mode	Manual/Auto Tuning Selector
8	Auto	Auto Tuning Mode	
9	UP	UP Operation Key Input	UP/DOWN Tuning Selector
10	Down	Down Operation Key Input	
11	STO	Memory Store Command Input	Memory at preset memory operation
12	M1	Preset Memory Channel Designation Inputs	Random Access for 16-Preset-Memory with the inputs of MC1/MC2
19	M8		
20	MC1	Memory Control Input	8 Stations (FM/AM)
21	MC2		16 Stations (FM + MW + LW)
			Preset Memory Selector
22	OSC2	AM SCAN OSC Terminal	CR Connector Terminal for AM Search Scan Speed
23	OSC1	FM SCAN OSC Terminal	CR Connection Terminal for FM Search Scan Speed
24	O/5	FM 50kHz Output	Level "H" Output for 50kHz Step (S. Africa and Europe area)
25	CK2	Receiving Frequency Data Serial Output	Supply Serial Data & Timing Clock to TD6301AP (Receiving Frequency Digital Display Driver)
26	CK1		
27	Data		CK1 Also supplies "PEE" sound Output Signal
28	Mute	Muting Signal Output	Level "H" Output when Muting
29	E2	Area Designation Input	Area Selector (Japan, US, Europe, S. Africa)
30	E1		
31	Stop 3	AM IF Signal Input	Not used (Connected to VDD terminal to avoid the malfunction by noise)
32	Stop 2	Auto Search Stop Signal Input	Stops Auto Search at Level "H" while Level "H" at Stop 1
33	Stop 1	Scan Speed Slow-Down Input	1/2 Speed-Down of Auto Search at Level "H"
34	DO-2	Phase Comparator Output	Phase Comparator Output
35	DO-1		
36	Test	Test Terminal	Test Mode at Level "H"
37	FM in	FM Programable Counter Input	Connected to Prescaler (TD6104P) Output
38	PSC	Prescaler Control Output	Count-Down (1/30, 1/32) Designation Out-put for Prescaler
39	AM in	AM Programable Counter Input	AM Local OSC Signal Input
40	$\overline{INH}$	Inhibit Input	Normal at Level "H" Initialize at Level "L"
41	$\overline{INT}$	Initialize Input	Normal at Level "H" Initialize at Level "L"
42	VDD	Power Terminal	+5V is supplied

# TD6104P



Pin No.	Symbol	Description
1	Vcc	+5V
2	OUT-2	Inverted output of OUT-1
3	OUT-1	Count-Down Frequency Output ( $f_{in}/30$ or $f_{in}/32$ )
4	GND	Ground
5	f IN	FM Local OSC Input
6	C	Bypass capacitor terminal for bias circuit
7	PSC	Count-Down-Ratio Switch Signal Input 1/32 at $V_{psc} \geq 2V$ 1/30 at $V_{psc} \leq 1V$

TD6301P

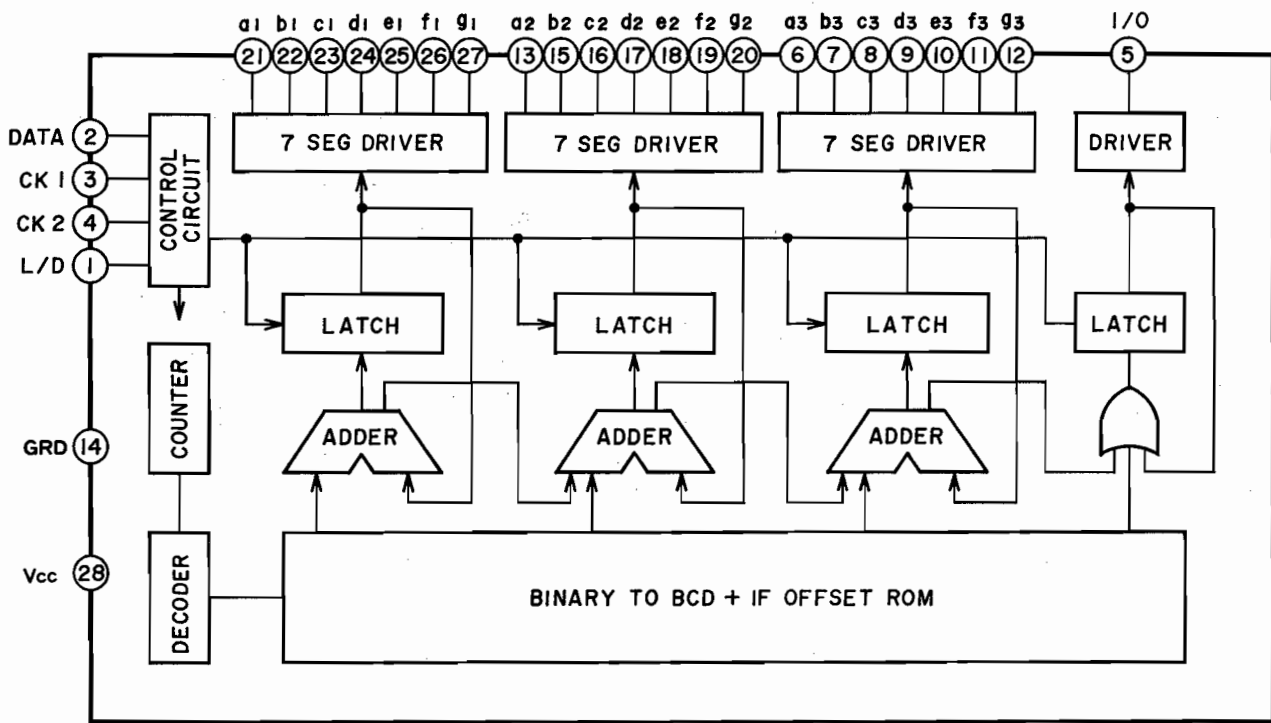

TD6301AP

Pin No.	Symbol	Description
1	L/D	Output Select Signal Input Terminal (To change the output for various display such as LED, FLD & LCD)
2	Data	Receiving Frequency Data Input Terminal (Serial Input from System Controller LSI)
3	CK1	Control Timing Input Terminal for Receiving Frequency Data Input (Simultaneously W/Data from System Controller LSI)
4	CK2	
5	1/0	Segment Driver Output Terminal for: FM: 100 <sup>s</sup> MHz AM: 1000 <sup>s</sup> kHz
6 } 12	a3 } g3	7 Segment Driver Output Terminals for: FM: 10 <sup>s</sup> MHz AM: 100 <sup>s</sup> kHz
13 } 15 } 20	a2 } g2	7 Segment Driver Output Terminals for: FM: 1 <sup>s</sup> MHz AM: 10 <sup>s</sup> kHz
21 } 27	a1 } g1	7 Segment Driver Output Terminals for: FM: 100 <sup>s</sup> kHz AM: 1 <sup>s</sup> kHz
14	VCC	+5V
28	GND	Ground



6-4. FM PLL SYNTHESIZER (MODEL AT-M5/L, AT-M5L/FR)

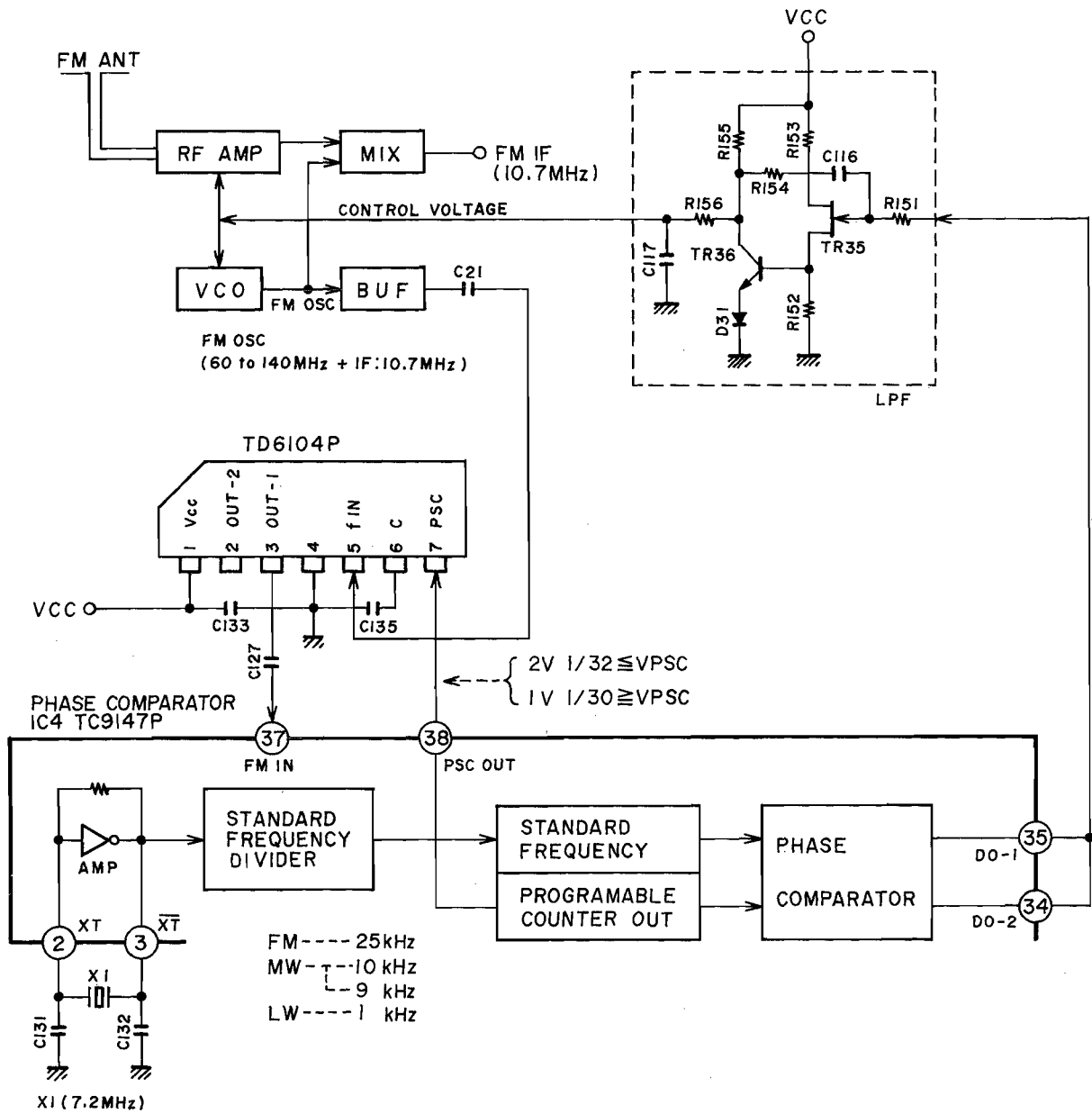

Fig. 6-4

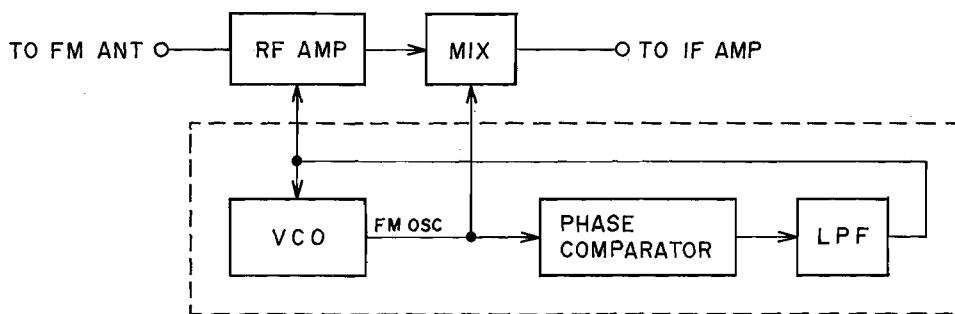

Fig. 6-5 PLL Basic Structure

## 6-5. AM TUNING AND AM VCO CIRCUIT

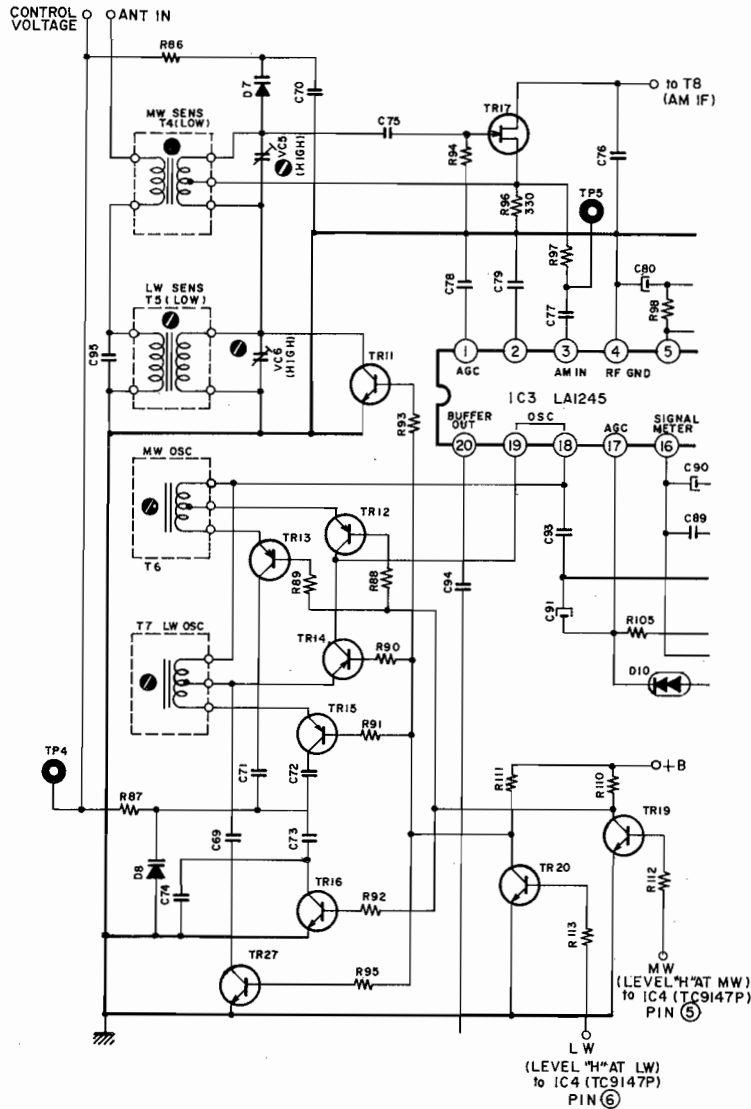

Fig. 6-6

### 6-5-1. AM TUNING CIRCUIT (MODEL AT-M5L) (Refer to Fig. 6-6)

- 1) For MW, the pin ⑥ of IC4 is at "L" level, and so TR20 is OFF, and TR11 is ON; i.e. T5 and VC6 are effectively short circuited and only T4 and VC5 are effectively connected to TR17.
- 2) For LW, the pin ⑥ of IC4 is at "H" level, and so TR20 is ON and TR11 is OFF, and T5 and VC6 are connected through T4 and VC5 to TR17.

### 6-5-2. AM VCO CIRCUIT (Refer to Fig. 6-6, 7, 8)

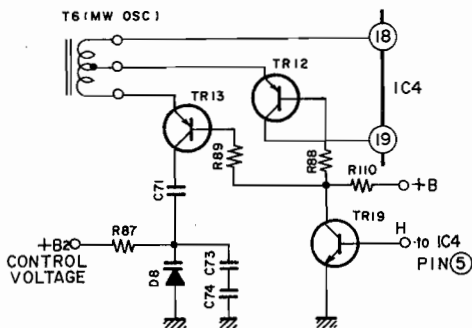

Fig. 6-7 MW OSC

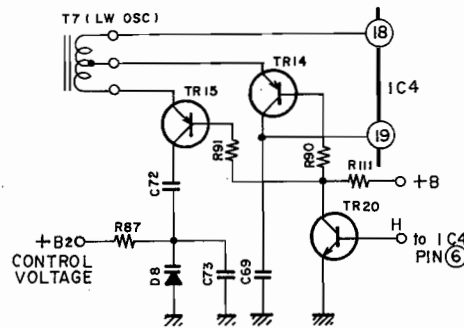

Fig. 6-8 LW OSC

- 1) For MW, the pin ⑤ of IC4 is at "H" level, and so TR19 is ON, TR16 OFF, TR12 and TR13 ON, TR20 is OFF and so TR14 and T15 are OFF. This means that T6, C71, C73, C74 and D8 are connected through TR19, TR12 and TR13, to create the MW OSC state (refer to Fig. 6-7).
- 2) For LW, the pin ⑥ of IC4 is at "H" level and the reverse operation to Paragraph 1 is conducted. This means T7, C69, C72, C73 and D8 are connected to create the LW OSC state (refer to Fig. 6-8).

## 6-6. AUTO TUNING (Refer to Fig. 6-9)

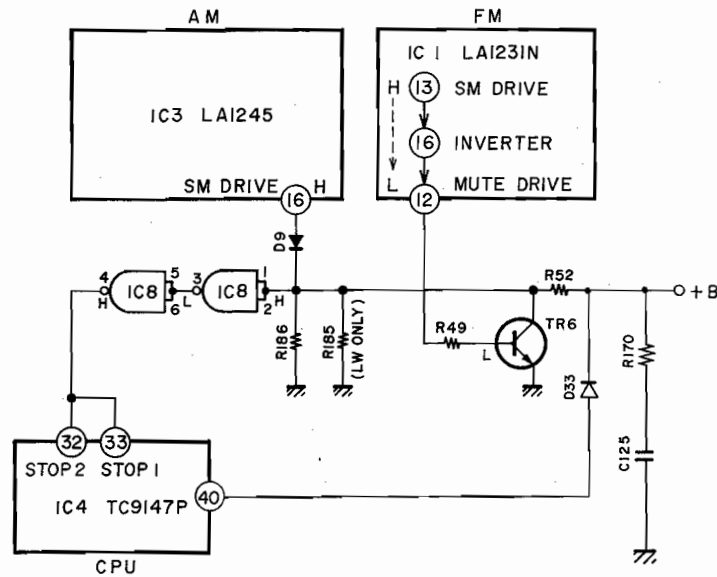

Fig. 6-9 Auto Stop Signal

**6-6-1.** When the tuning mode is set AUTO and the UP/DOWN SCAN is pressed, this feature searches automatically through the broadcasting frequency range and stops, when a station is detected.

**6-6-2.** For FM, the trailing edge of the voltage at the pin (12) of IC1 (LA1231N) is detected as the auto stop signal, and for AM the leading edge of the voltage at the pin (16) of IC3 (LA1245) is detected.

**6-6-3.** The auto-search tuning is released in any of the following 4 ways.

1. When switched to manual scan mode

2. When band is changed

3. When reading of the preset memory is started

4. When switched to inhibit mode

The inhibit mode means that the pin (40) of IC4 (TC9147P) is at "L" level (usually "H").

**6-6-4.** When the tuning mode is manual, a 1 push/1 step tuning system operates, but when the UP/DOWN SW is continuously pressed, the manual fast tuning mode is created. The tuning speed, as in the case of auto tuning, is determined by C128/R177 and C129/R178 connected to IC4 (TC9147P) (22) OSC 2 (for AM) and (23) OSC1 (for FM) respectively.

## 6-7. CPU IC4 (TC9147P) BACK-UP (Refer to Fig. 6-10)

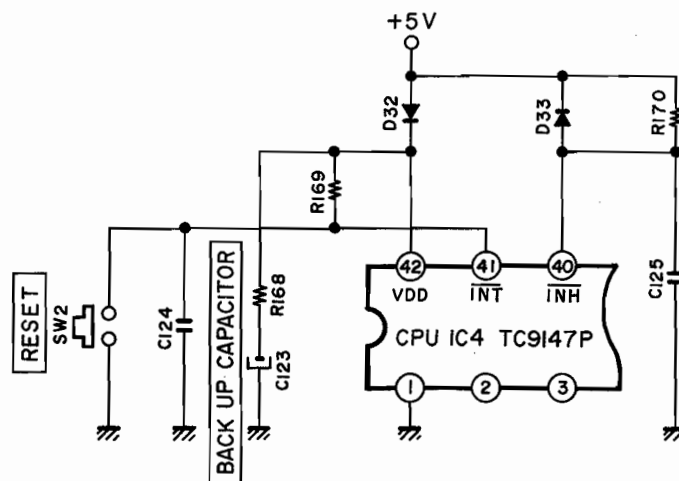

Fig. 6-10

For the back-up power source, a capacitor (C123) called "super capacitor" is used and it can provide a voltage back-up for about 2 weeks. (when C123 is 0.047F, 0.5-1V)

However, when the voltage drops below that value, the power ON does not reset smoothly and causes malfunction. In order to reset in such a case, a Reset SW is

provided on the rear panel. When the CPU is not backed-up, the reset circuit operates to initialize the IC internal circuitry so that the display will be:

FM 76.00 MHz (AT-M5 J only)

FM 87.50 MHz (other models)

and the external SW will be in FM-AUTO and SCAN-MANUAL.

## 6-8. MUTE CIRCUIT (Refer to Fig. 6-11)

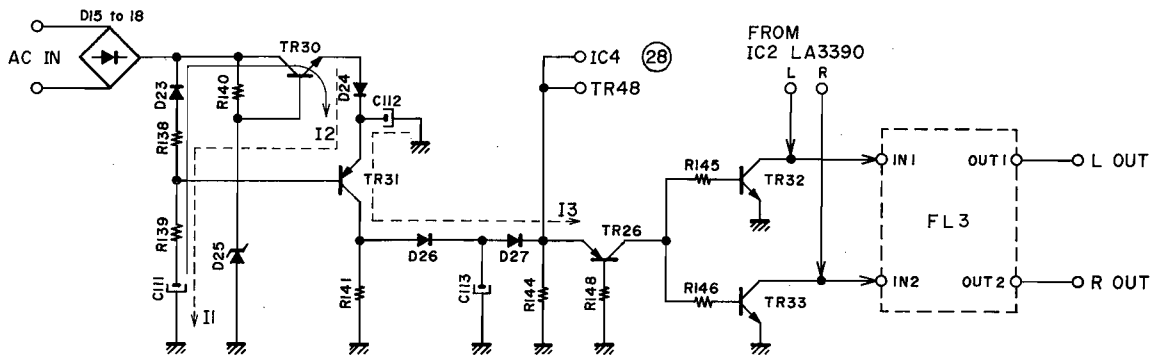

Fig. 6-11

1) The mute state is created in three ways; i.e. when power is turned ON/OFF, or when the signals from MICOM (IC4) Pin(28) or from TR48 become "H" level.

2) When the power is turned ON, the charging current I1 flows. Until the charging of C111 and C112 is completed, TR30-33 remain ON, so that the final signal output is shorted or muted by using the leading edge of the voltage when the power is turned ON. When the power is turned OFF, C111 and C112 are

discharged by the discharging currents (I2, I3). Until the discharging is completed TR30-33 remain ON, and as in the above case, the mute operates (within 3 seconds).

3) When the band is changed (0.5 - 1.5 seconds) and during the scan tuning, the pin (28) of IC4 becomes "H" level and when the mode is changed, the collector of TR48 becomes "H" level, so that the mute also operates in these two cases.

## 6-9. MODE SW (FM AUTO/MONO) (Refer to Fig. 6-12)

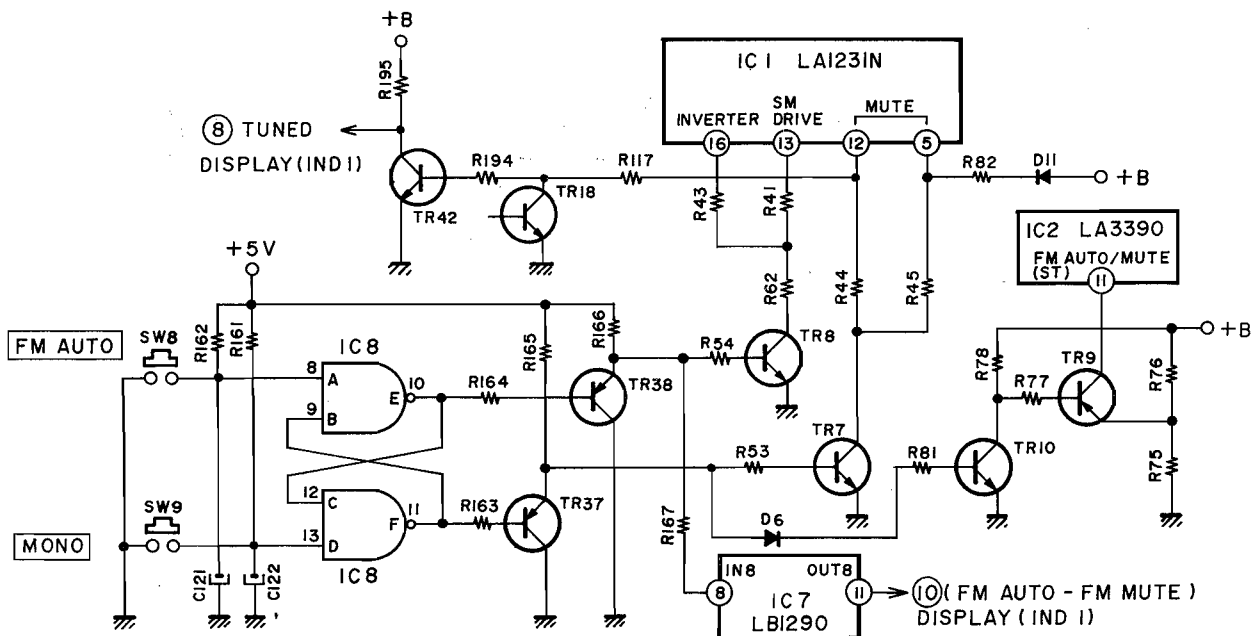

Fig. 6-12

1) In initial state or when the power is turned ON, the input of IC8 is A="H", B="L", C="H" and D="H", and the output is E="H" and F="L". Therefore, TR37 is ON, TR7 OFF, the pin (5) of IC1 is "H" and the mute control is available. Secondly TR10 and TR9 are OFF and the pin (11) of IC2 is "L", so instead of forced mono, FM AUTO (stereo) mode is created. Thirdly, TR38 becomes OFF, and so the pin (8) of IC7 is "H" and the pin (11) is also "H", and the FM AUTO-FM MUTE connected to the pin (10) of the display (IND1) lights.

2) When in MONO mode (SW9 ON), the input of IC8 is A="H", B="H", C="L" and D="L", and the output is E="L", and F="H". Therefore, TR38 is ON, the pin (8) of IC7 is "L", the pin (11) also "L", and the FM AUTO-FM MUTE goes out. Secondly, TR37 is OFF, TR7 ON, the pin (5) of IC1 is "L" so that there is no mute control. Thirdly TR10 and TR9 are ON, and so the pin (11) of IC2 becomes "H" and the forced MONO state is created.

\* TR8 is a transistor for determining the scan stop level when in FM AUTO.

# VII. ELECTRICAL ADJUSTMENT

## 7-1. THE INSTRUMENT CONNECTIONS

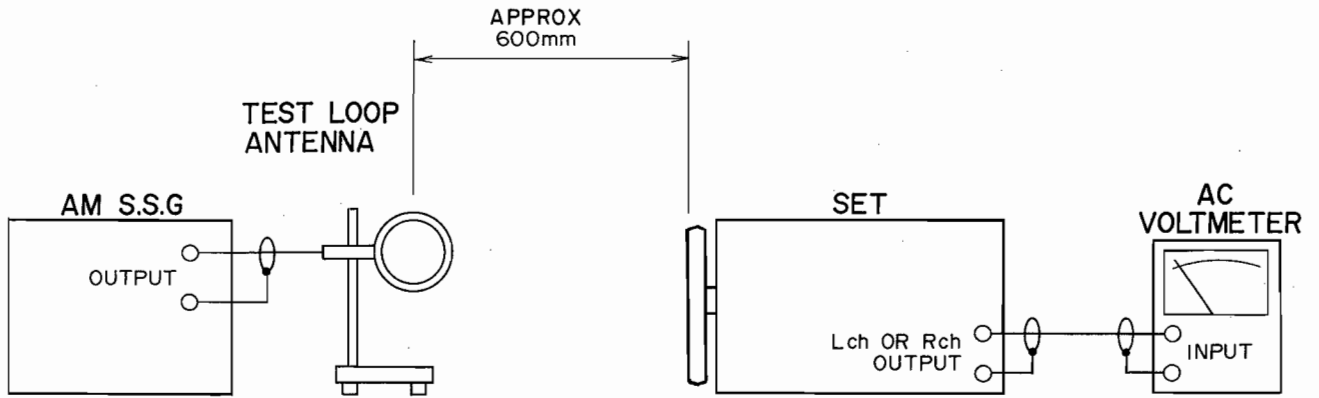

Fig. 7-1 Instrument Connections for AM (MW, LW) Section Adjustment

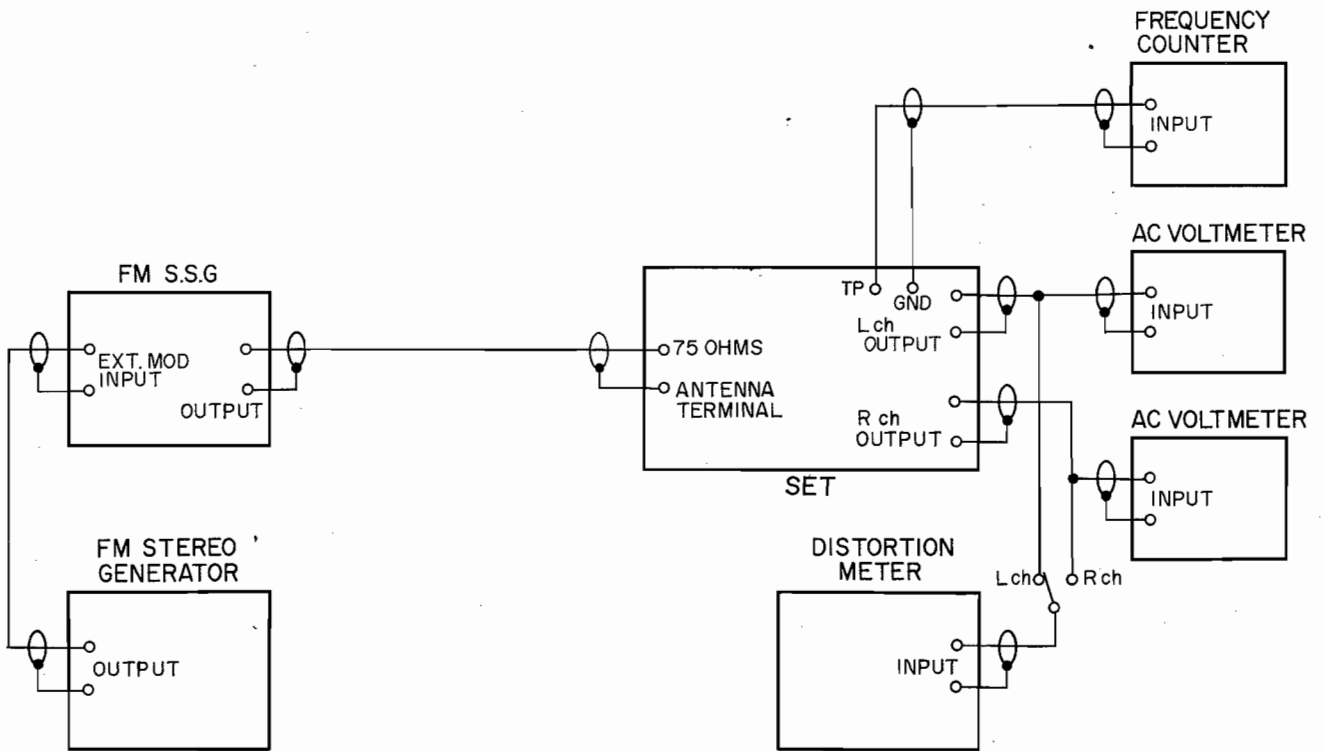

Fig. 7-2 Instrument Connections for FM Section Adjustment

## 7-2. THE VIEW OF ADJUSTMENT POINTS

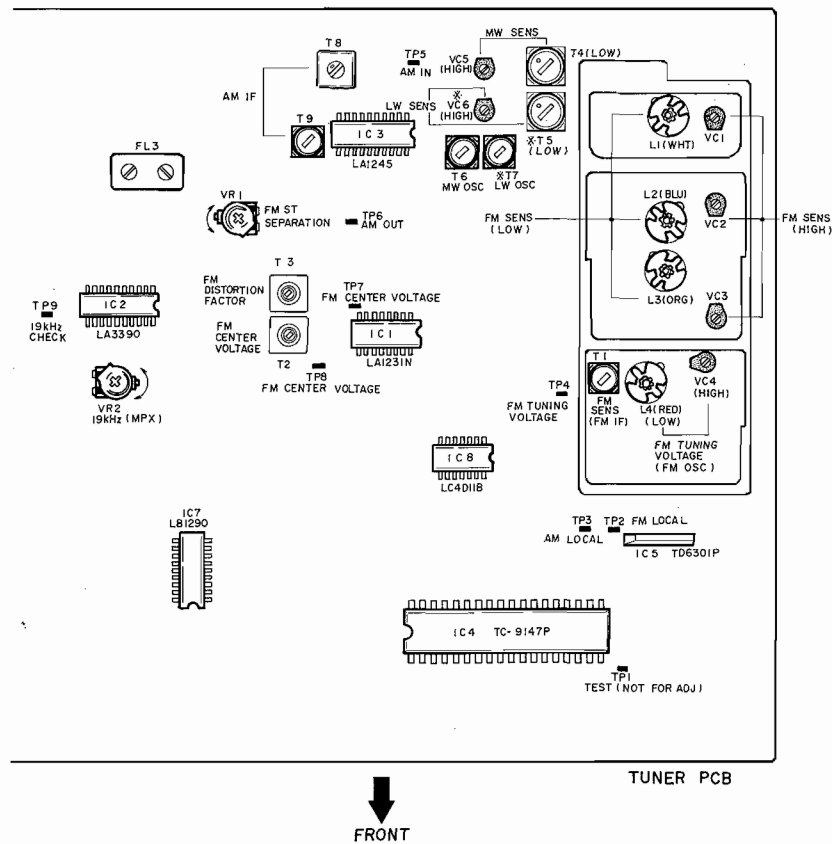

Fig. 7-3 Tuner P.C.B. (Model AT-M5/L)(T5, T7, VC-6 are deleted on Model AT-M5.)

## 7-3. MW AND LW SECTION ADJUSTMENT (Refer to Figs. 7-1, 3)

Step	Adjustment Item	Adjustment Point	Test Point	Result	Remarks
1	MW OSC	T6	TP3 TP4	2±0.01V (522kHz) Less than 25V (1611kHz)	Selector to MW Frequency counter to TP3. Volt Meter to TP4
2	AM IF	T8, 9	Output	Maximum output	1000kHz (999kHz), 50dB, 400Hz (30%) Input
3	Low Range Sensitivity	T4	Output	Maximum output Less than 10% distortion factor	600kHz (603kHz), 60dB, 400Hz (30%) Input
4	High Range Sensitivity	VC5	Output	Maximum output Less than 10% distortion factor	1400kHz (1404kHz), 60dB, 400Hz (30%) Input
5	LW OSC	T7	TP3 TP4	2±0.01V (153kHz) Less than 25V (360kHz)	Selector to LW Frequency counter to TP3. Volt Meter to TP4
6	Low Range Sensitivity	T5	Output	Maximum output Less than 10% distortion factor	164kHz, 65dB, 400Hz (30%) Input
7	High Range Sensitivity	VC6	Output	Maximum output Less than 10% distortion factor	299kHz, 65dB, 400Hz (30%) Input

NOTE: 1. For the best result, repeat step 1 through 7 for two or three times.  
2. (      kHz) in remarks indicates the test frequency for AM 9kHz step area.

#### 7-4. FM SECTION ADJUSTMENT (Refer to Figs. 7-2, 3)

Step	Adjustment Item	Adjustment Point	Test Point	Result	Remarks
1	FM Tuning Voltage (Low)	L4	TP4	3.0V	Selector to FM, Display to 88MHz, Digital Volt Meter Between TP4 & GND.
2	FM Tuning Voltage (High)	VC4	TP4	20V	Display to 108MHz
3	Low Range Sensitivity	L1, 2, 3 T1	Output	Less than 6dB	Mode to Mono. 88MHz, 1kHz (Mono, 100%) Input, 3% DISTORTION FACTOR
4	High Range Sensitivity	VC1, 2, 3	Output	Less than 6dB	108MHz, 1kHz (Mono, 100%) Input, 3% DISTORTION FACTOR
5	FM Center Voltage	T2	TP7 TP8	Centered Tuning Meter Indication	Center Tuning Meter Between TP7 & TP8, (see NOTE 1) Tunes only noise without interference from Broadcasting
6	Distortion Factor	T3	Output	Less than 0.3%	98MHz, 60dB, 1kHz (Mono, 100%) Input
7	MPX Free Running Frequency	VR2	TP9	19kHz±50Hz	Mode SW to FM Auto, Frequency counter to TP9, 98MHz Non-Modulation Signal Input
8	Stereo Separation	VR1	Output	More than 40dB	98MHz, 60dB, 1kHz (Stereo, 100%) LCH (RCH) Input, RCH (LCH) output to Minimum

- NOTE: 1. The center tuning meter such as the ones used on model AA-R20, 30, 40, 50 & AT-2400, 2600 can be used for this adjustment.  
If it is not available, use a digital meter (DC VOLTAGE, RANGE 20V) instead, and adjust T2 so that it indicates 0V at the same condition.
2. For the best result, repeat step 1 through 8 for two or three times.

## VIII. CLASSIFICATION OF VARIOUS P.C BOARDS

---

### 8-1. MODEL AT-M5/L, M5L/FR P.C BOARD TITLES AND IDENTIFICATION NUMBERS

P.C BOARD TYTLE	P.C BOARD NUMBER	REMARKS
TUNER	A3038A501A	U (AT-M5)
TUNER	A3038A502A	J (AT-M5)
TUNER	A3038A503A	C, A (AT-M5)
TUNER	A3038A504A	E, V, S (AT-M5)
TUNER	A3038A505A	E, B (AT-M5L)
OPERATION	A3038A501B	U (AT-M5)
OPERATION	A3038A502B	J (AT-M5)
OPERATION	A3038A503B	C, A (AT-M5)
OPERATION	A3038A504B	E, V, S (AT-M5)
OPERATION	A3038A505B	E, B (AT-M5L)
FLD	A3038A501C	U (AT-M5)
FLD	A3038A502C	J (AT-M5)
FLD	A3038A503C	C, A (AT-M5)
FLD	A3038A504C	E, V, S (AT-M5)
FLD	A3038A505C	E, B (AT-M5L)



## 8-2. COMPOSITION OF VARIOUS P.C BOARDS

### 1) TUNER P.C BOARD A3038A501A~504A (AT-M5)

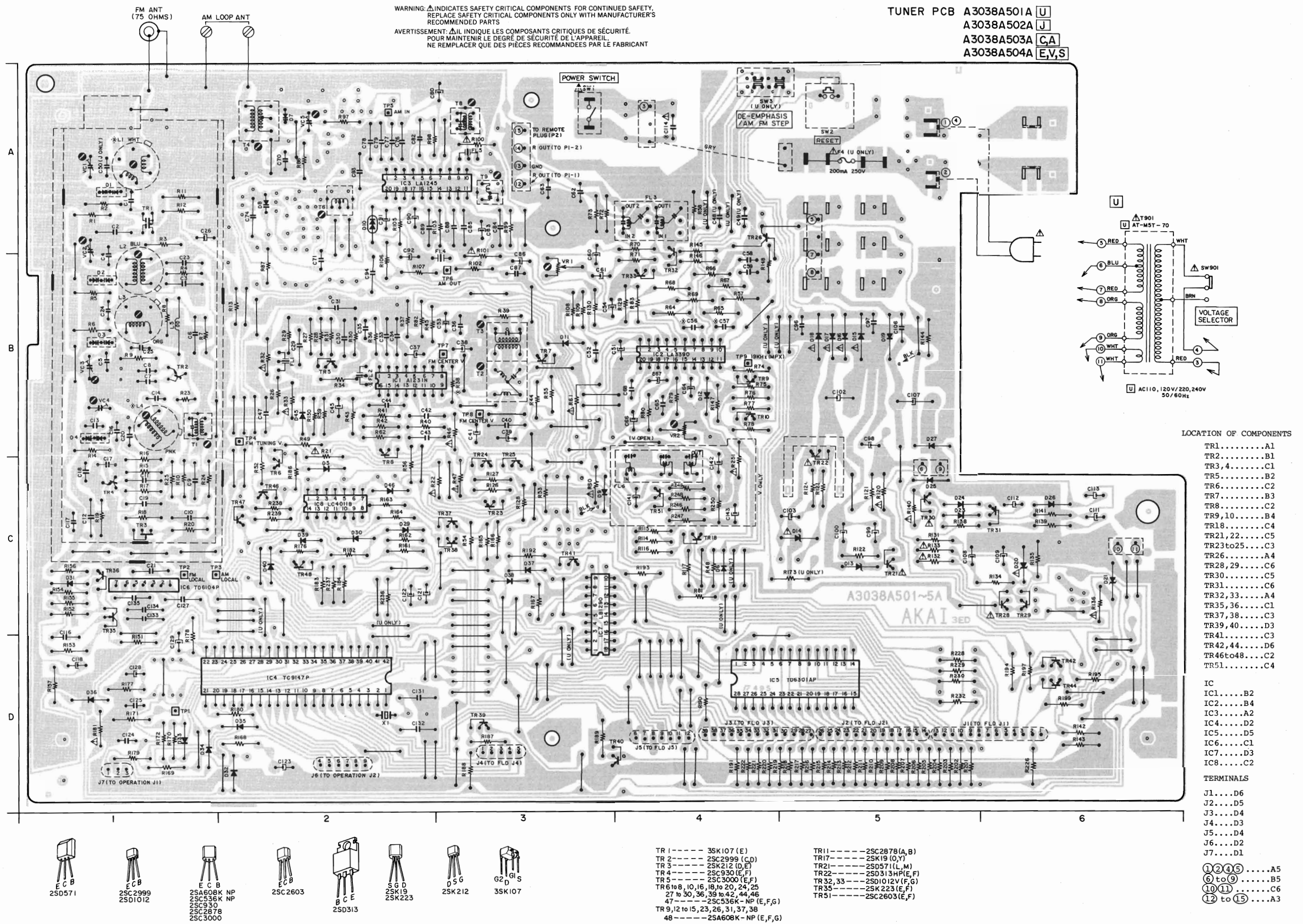

2) TUNER P.C BOARD A3038A505A (AT-M5L)

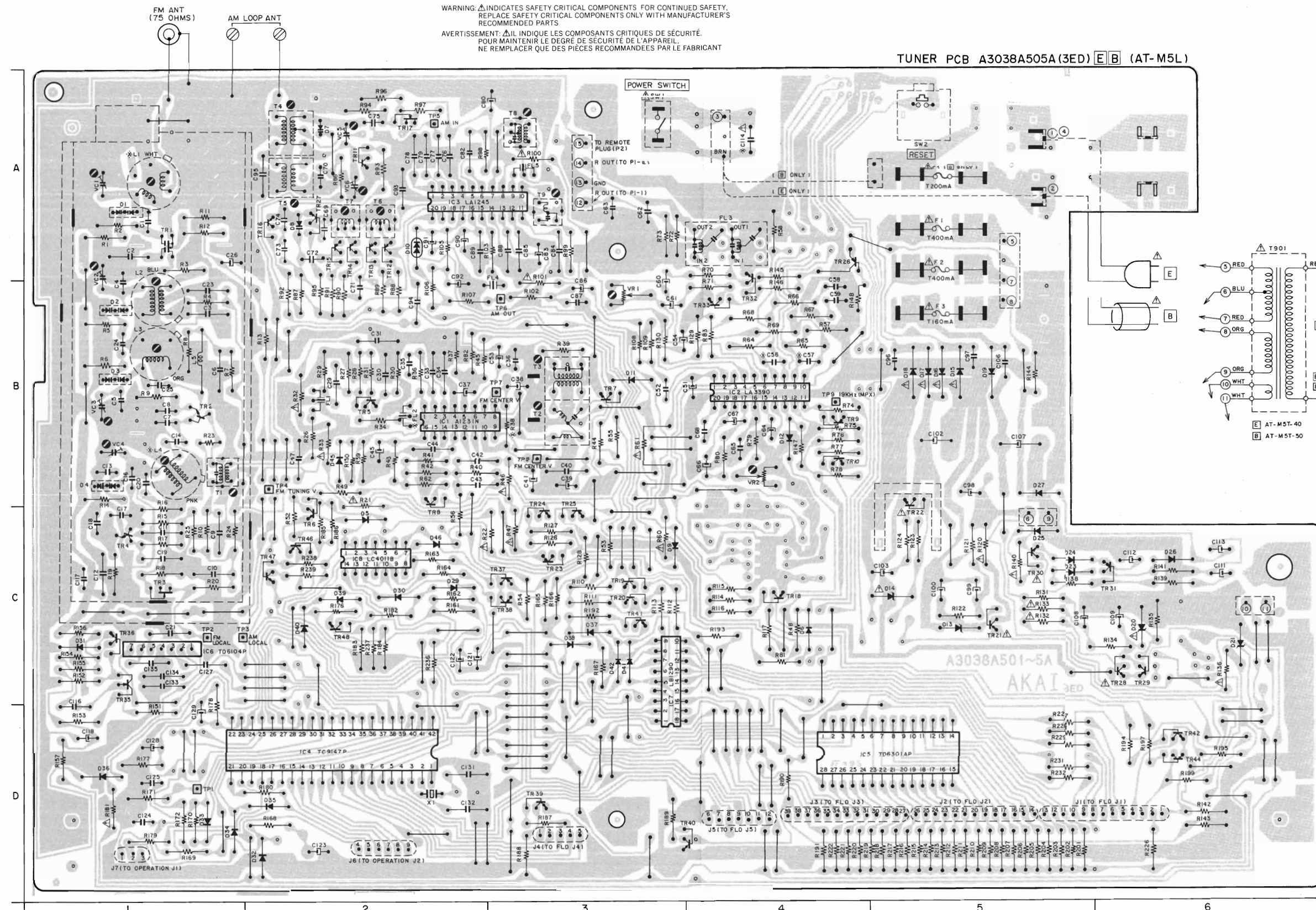

WARNING: Δ INDICATES SAFETY CRITICAL COMPONENTS FOR CONTINUED SAFETY. REPLACE SAFETY CRITICAL COMPONENTS ONLY WITH MANUFACTURER'S RECOMMENDED PARTS.  
 AVERTISSEMENT: Δ IL INDIQUE LES COMPOSANTS CRITIQUES DE SÉCURITÉ. POUR MAINTENIR LE DEGRÉ DE SÉCURITÉ DE L'APPAREIL, NE REMPLACER QUE DES PIÈCES RECOMMANDÉES PAR LE FABRICANT.

TUNER PCB A3038A505A (3ED) [E][B] (AT-M5L)

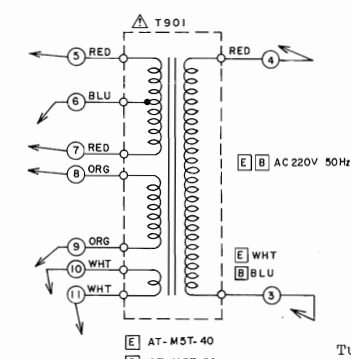

- Tuner
- TUNER P.C BOARD
- IC  
 IC1.....B2  
 IC2.....B4  
 IC3.....A2  
 IC4.....D2  
 IC5.....D5  
 IC6.....C1  
 IC7.....D3  
 IC8.....C2
- TR  
 TR1.....A1  
 TR2.....B1  
 TR3,4.....C1  
 TR5.....B2  
 TR6.....C2  
 TR7.....B3  
 TR8.....C2  
 TR9,10.....B4  
 TR11to18.....A2  
 TR19,20.....C3  
 TR21,22.....C5  
 TR23to25.....C3  
 TR26.....A4  
 TR27.....A2  
 TR28,29.....C6  
 TR30.....C5  
 TR31.....C6  
 TR32,33.....A4  
 TR35,36.....C1  
 TR37,38.....C3  
 TR39,40.....D3  
 TR41.....C3  
 TR42,44.....D6  
 TR46to48.....D6  
 TR51.....C4
- TERMINALS  
 J1.....D6  
 J2.....D5  
 J3.....D4  
 J4.....D3  
 J5.....D4  
 J6.....D2  
 J7.....D1  
 ①②④⑤.....A5  
 ⑥ to ⑨.....B5  
 ⑩, ⑪.....C6  
 ⑫ to ⑮.....A3

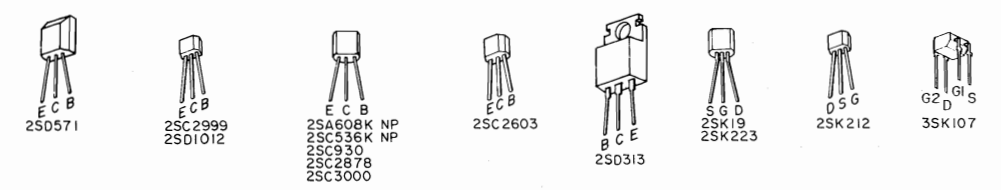

- TR 1 ---- 35K107 (E)  
 TR 2 ---- 25C2999 (C,D)  
 TR 3 ---- 25K212 (D,E)  
 TR 4 ---- 25C930 (E,F)  
 TR 5 ---- 25C3000 (E,F)  
 TR 6to8, 10, 16, 18, 20, 24, 25  
 27 to 30, 36, 39 to 42, 44, 46  
 47 ---- 25C536K-NP (E,F,G)  
 TR 9,12 to 15, 23, 26, 31, 37, 38  
 48 ---- 25A608K-NP (E,F,G)
- TR11 ---- 25C2878 (A,B)  
 TR17 ---- 25K19 (O,Y)  
 TR21 ---- 25D571 (L,M)  
 TR22 ---- 25D313HP(E,F)  
 TR 32, 33 ---- 25D1012V (F,G)  
 TR 35 ---- 25K223 (E,F)  
 TR51 ---- 25C2603 (E,F)

3) TUNER P.C BOARD POWER SUPPLY SECTION ONLY (J, CA, EVS)

TUNER PCB A3038A504A(3ED) [E,V,S] (AT-M5)

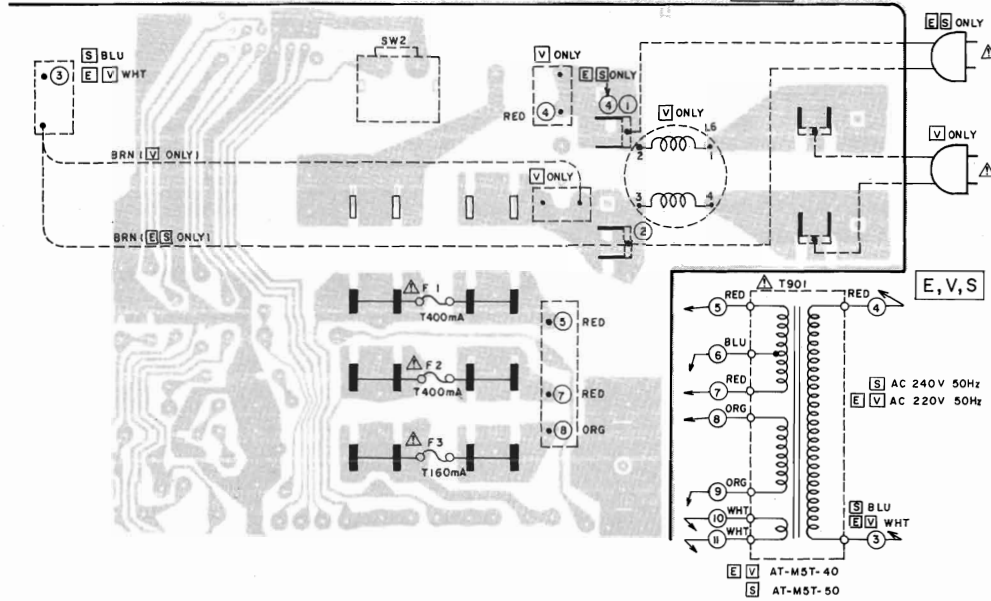

TUNER PCB A3038A503A(3ED) [A,C] (AT-M5)

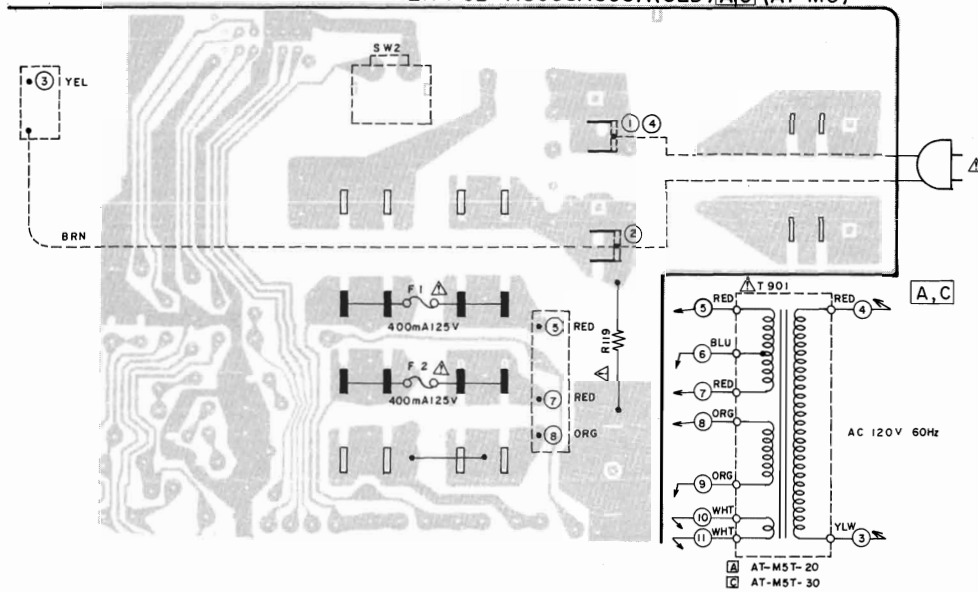

TUNER PCB A3038A502A(3ED) [J] (AT-M5)

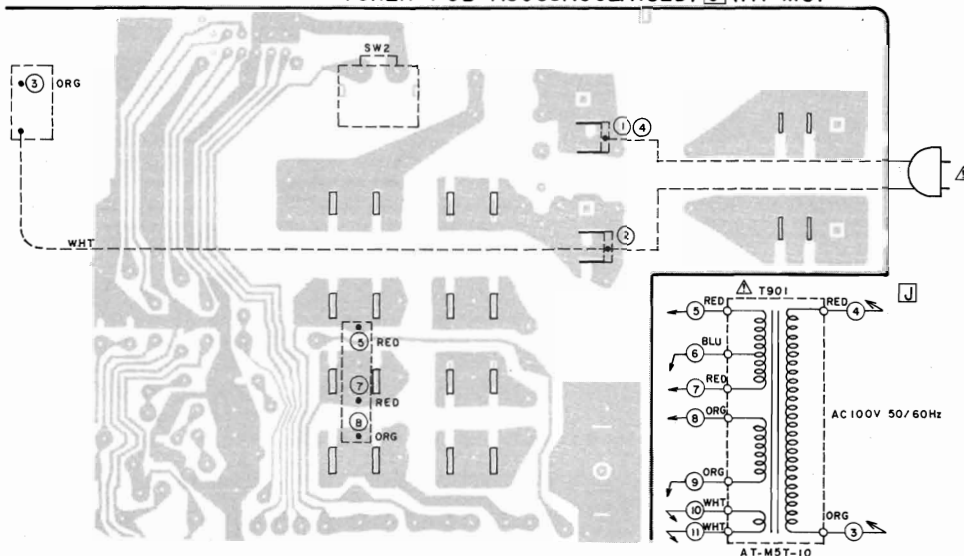

WARNING: A INDICATES SAFETY CRITICAL COMPONENTS FOR CONTINUED SAFETY.  
 REPLACE SAFETY CRITICAL COMPONENTS ONLY WITH MANUFACTURER'S  
 RECOMMENDED PARTS.  
 AVERTISSEMENT: AIL INDIQUE LES COMPOSANTS CRITIQUES DE SÉCURITÉ.  
 POUR MAINTENIR LE DEGRÉ DE SÉCURITÉ DE L'APPAREIL,  
 NE REMPLACER QUE DES PIÈCES RECOMMANDÉES PAR LE FABRICANT.

4) OPERATION P.C BOARD A3038A501B~ 505B

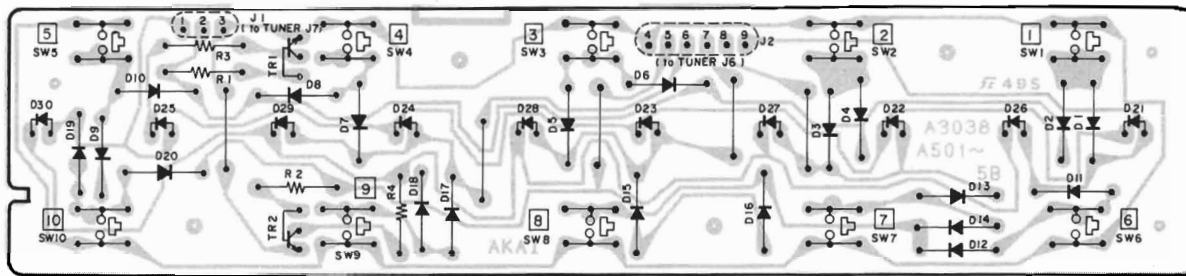

OPERATION PCB A3038A501Bto505B(ALL MODELS)

5) FLD P.C BOARD A3038A501C~ 504C (AT-M5)

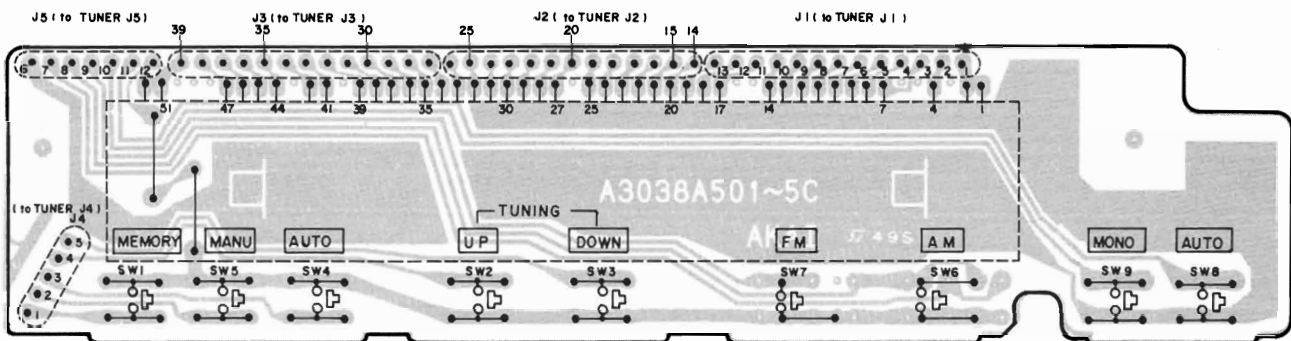

FLD PCB (AT-M5)

- A3038A501C  U
- A3038A502C  J
- A3038A503C  C, A
- A3038A504C  E, V, S

6) FLD P.C BOARD A3038A505C (AT-M5L)

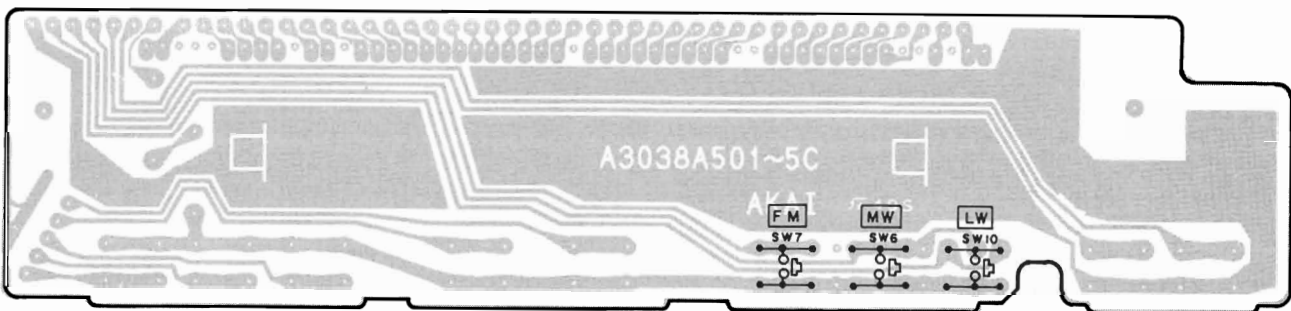

FLD PCB A3038A505C  E, B  
(AT-M5L)

---

SECTION 2

**CIRCUIT OPERATION DESCRIPTION**

TABLE OF CONTENTS

I.	OUTLINE OF AM-M5 AND AM-M7 .....	28
	1. SELECTION OF INPUT SIGNAL .....	28
	2. VOLUME CONTROL .....	28
	3. LONG-TERM BACK-UP BY CAPACITOR .....	28
	4. GRAPHIC EQUALIZER TERMINAL .....	28
	5. AUTO FUNCTION CONTROL SYSTEM .....	28
II.	OPERATION OF CONTROL IC AA-100 PERIPHERAL CIRCUIT .....	29
	1. AA-100 PERIPHERAL BLOCK DIAGRAM .....	29
	2. AA-100 TERMINALS DESCRIPTION .....	30
	3. OPERATION OF CONTROL IC AA-100 PERIPHERAL CIRCUIT ..	31
III.	MAIN AMPLIFIER .....	32
	1. AKAI ZERO DRIVE CIRCUIT (AM-M7 ONLY) .....	32
	2. DUAL POLE SERVO CIRCUIT.....	32
	3. PROTECTION CIRCUIT (AM-M7) .....	32
IV.	POWER MUTE CIRCUIT .....	33
	1. WHEN POWER IS ON .....	33
	2. WHEN POWER IS OFF .....	33
V.	AUTO FUNCTION CONTROL .....	34

# I. OUTLINE OF AM-M5 AND AM-M7

AM-M5/M7 use a microcomputer (AA-100) to control the system operation, and all the functions (input select, volume, tone control, etc.) which have been provided by mechanical means so far, are now executed electronically.

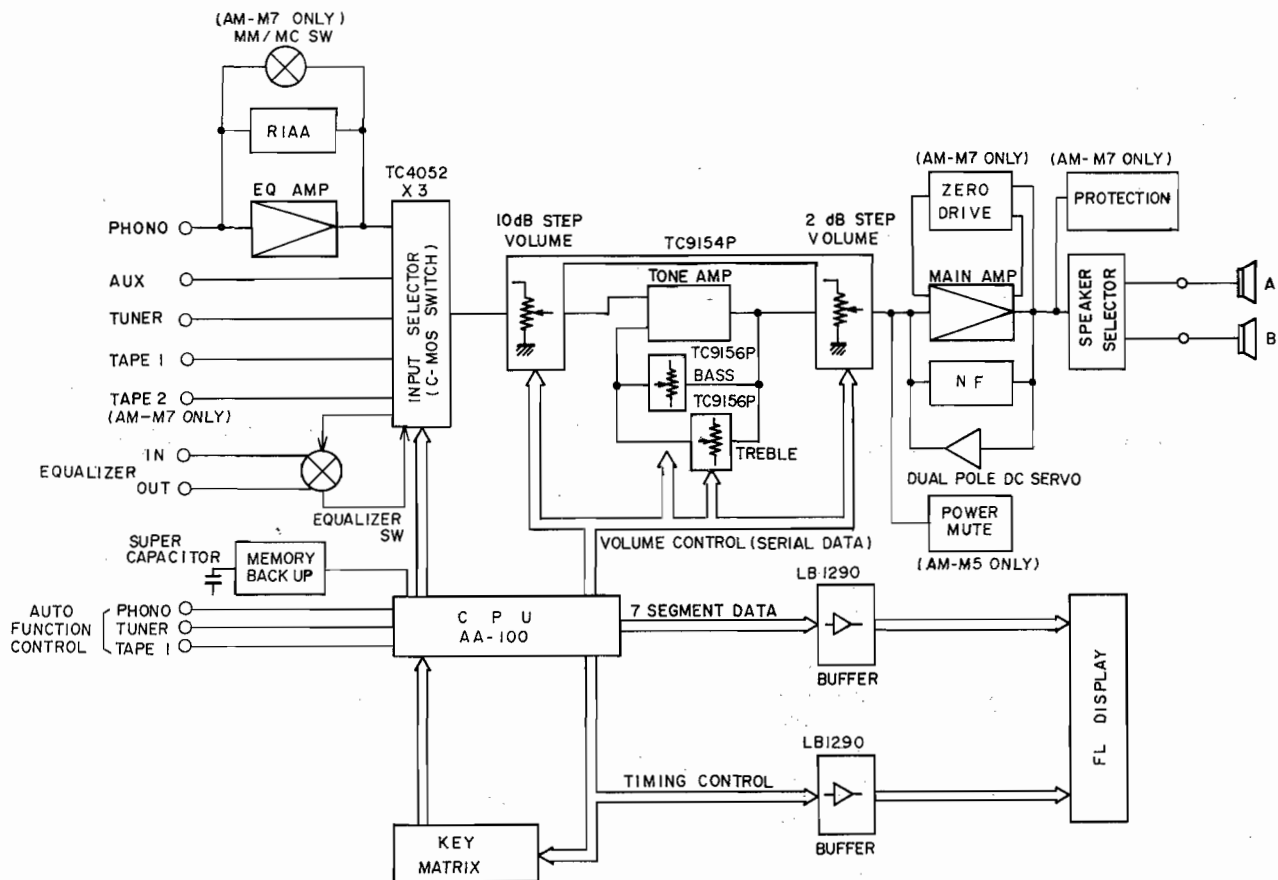

Fig. 1-1 Block Diagram of AM-M5/M7

## 1-1. SELECTION OF INPUT SIGNAL

In accordance with the buttons, PHONO, BAND, AUX, TAPE 1 and TAPE 2, AA-100 controls the C-MOS analog switch (TC4052x3) to select the appropriate analog signal.

## 1-2. VOLUME CONTROL

AA-100 transfers serially the level data corresponding to the UP or DOWN action to the volume IC to change the volume level.

## 1-3. LONG-TERM BACK-UP BY CAPACITOR

AA-100 micro-computers for C-MOS processing, have very low current consumption in hold mode, thus enabling long-term back-up by a capacitor to be realized. This provides the last-setting memory which maintains the prior status when the power is OFF. However the volume position will be reset at -26 dB in order to protect the speaker for the case where the power went off at a volume level higher than the prescribed level of -26 dB.

## 1-4. GRAPHIC EQUALIZER TERMINAL

The AKAI Graphic Equalizer EA-M7 can be connected directly to the Jacks provided exclusively for an equalizer.

## 1-5. AUTO FUNCTION CONTROL SYSTEM

When you use the Akai AM-M7 in combination with the Akai Player system AP-M7 or AP-M5, the Akai Stereo cassette Deck HX-M7R or HX-M5 and the Akai Quartz Synthesizer Tuner AT-M5/L, you can enjoy the convenient auto function control. Just by depressing the operating button of each component, the Akai AM-M7's input source selector will be set automatically. The auto function control inside each component sends a control signal to the Akai AM-M7 which is then detected by a micro-computer. This micro-computer then sets the Akai AM-M7's input source selector to whichever signal is detected. Therefore, you can switch from tape playback to record playback or radio reception without touching the Akai AM-M7's input source selector. AM-M5 operates in the same way.

\* Auto function control does not function for components connected to the AUX and TAPE 2 jacks on AM-M7.

---

SECTION 2

**CIRCUIT OPERATION DESCRIPTION**

TABLE OF CONTENTS

I.	OUTLINE OF AM-M5 AND AM-M7 .....	28
	1. SELECTION OF INPUT SIGNAL .....	28
	2. VOLUME CONTROL .....	28
	3. LONG-TERM BACK-UP BY CAPACITOR .....	28
	4. GRAPHIC EQUALIZER TERMINAL .....	28
	5. AUTO FUNCTION CONTROL SYSTEM .....	28
II.	OPERATION OF CONTROL IC AA-100 PERIPHERAL CIRCUIT .....	29
	1. AA-100 PERIPHERAL BLOCK DIAGRAM .....	29
	2. AA-100 TERMINALS DESCRIPTION .....	30
	3. OPERATION OF CONTROL IC AA-100 PERIPHERAL CIRCUIT ..	31
III.	MAIN AMPLIFIER .....	32
	1. AKAI ZERO DRIVE CIRCUIT (AM-M7 ONLY) .....	32
	2. DUAL POLE SERVO CIRCUIT.....	32
	3. PROTECTION CIRCUIT (AM-M7) .....	32
IV.	POWER MUTE CIRCUIT .....	33
	1. WHEN POWER IS ON .....	33
	2. WHEN POWER IS OFF .....	33
V.	AUTO FUNCTION CONTROL .....	34

# II. OPERATION OF CONTROL IC AA-100 PERIPHERAL CIRCUIT

## 2-1. AA-100 PERIPHERAL BLOCK DIAGRAM

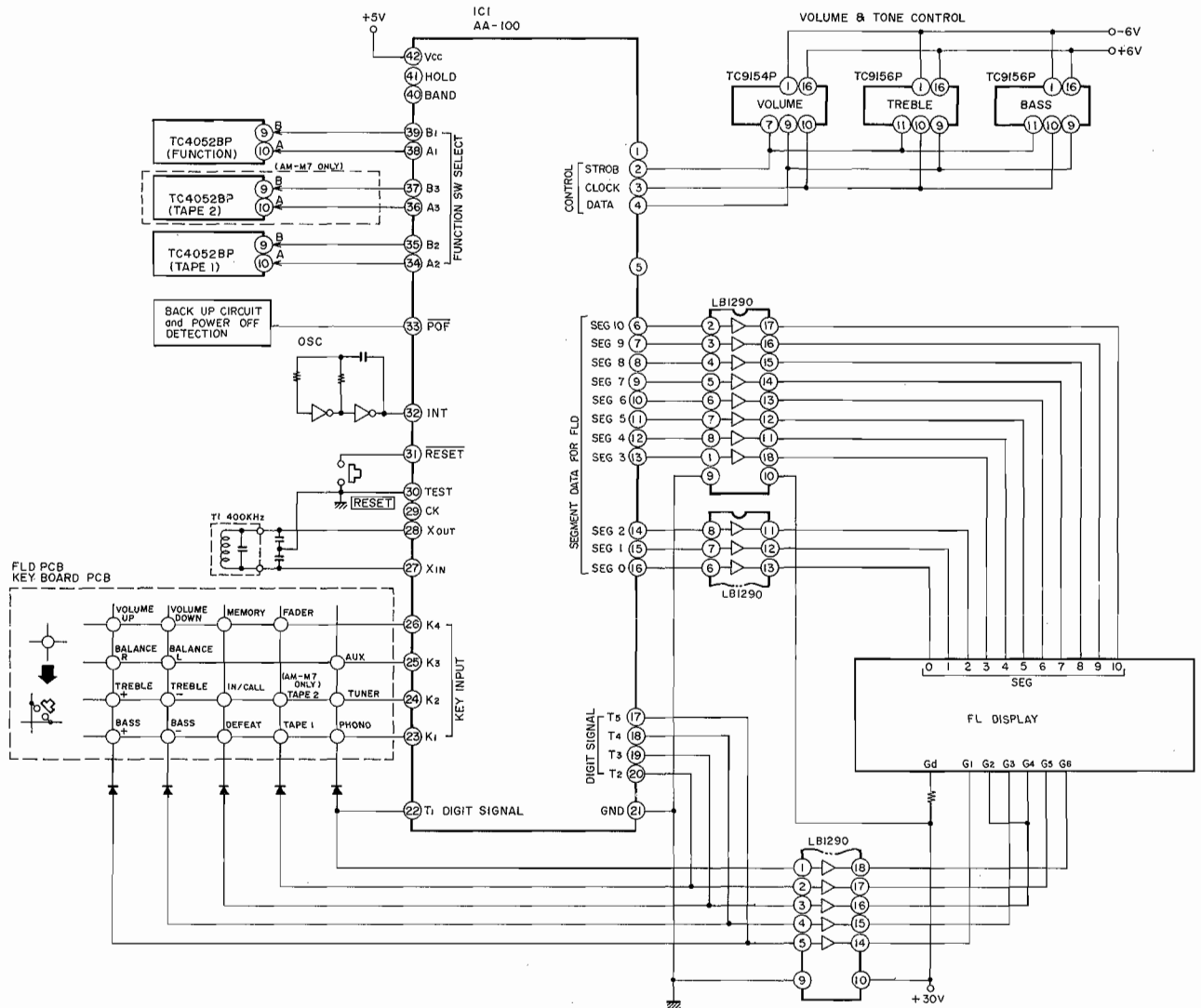

Fig. 2-1



## 2-2. AA-100 TERMINALS DESCRIPTION

No.	Terminal Description	Function
1	NC	
2	STROB	Output Control Signal for Elect. VR and TONE Output at ACTIVE "H"
3	CLOCK	
4	DATA	
5	CART (SEG11)	Output "H" when phono
6	SEG10	SEGMENT DATA for Display Output at ACTIVE "H"
7	SEG9	
8	SEG8	
9	SEG7	
10	SEG6	
11	SEG5	
12	SEG4	
13	SEG3	
14	SEG2	
15	SEG1	
16	SEG0	
17	T5	DIGIT Signal Output at ACTIVE "H"
18	T4	
19	T3	
20	T2	
21	GND	DIGIT Signal
22	T1	
23	K1	KEY Input Input at ACTIVE "H"
24	K2	
25	K3	
26	K4	
27	X <sub>IN</sub>	Clock OSC Coil
28	X <sub>OUT</sub>	
29	CK	unused
30	TEST	unused
31	RESET	Reset at ACTIVE "L"
32	INT	Interrupt Signal
33	POF	Power OFF at ACTIVE "H"
34	A2	FUNCTION SW Select Signal (B1, A1) . . . . . TUNER, PHONO, AUX (B2, A2) . . . . . Tape 1 (B3, A3) . . . . . Tape 2 Output at ACTIVE "H"
35	B2	
36	A3	
37	B3	
38	A1	
39	B1	
40	BAND	
41	HOLD	
42	Vcc	+5V

---

## **2-3. OPERATION OF AMPLIFIER SECTION CONTROL IC AA-100 PERIPHERAL CIRCUIT**

### **2-3-1. Display Data**

### **2-3-2. Digit Output of AA-100**

### **2-3-3. Description of Input Selector**

- 1) FUNCTION SWITCHING
- 2) TAPE MONITOR SWITCHING

### **2-3-4. Operation of Electronic Volume Control and Tone Control**

- 1) OPERATION OF VOLUME CONTROL
- 2) SERIAL TRANSFER DATA

### **2-3-5. Composition of Volume IC TC9154P and Tone Control (Bass Treble) IC TC9156P**

- 1) INTERNAL BLOCK DIAGRAM
- 2) ATTENUATOR OF TC9154P
- 3) INTERNAL BLOCK DIAGRAM OF TC9156P (BASS TREBLE)
- 4) VARIABLE RESISTOR OF TC9156P
- 5) OPERATION
- 6) UP/DOWN OPERATION OF VOLUME CONTROL
- 8) UP/DOWN OPERATION OF BASS AND TREBLE
- 9) BALANCE CONTROL
- 10) OPERATION OF FADER

### **2-3-6. The Status that will be Established When Reset Button is Pressed**

### **2-3-7. Reset Status when Power is on**

### **2-3-8. How to make Letters**

\*For the description of the above circuit which is identical to Model AA-R22/32/42, see the service manual for AA-22/  
32/42.

### III. MAIN AMPLIFIER

#### 3-1. AKAI ZERO DRIVE CIRCUIT (AM-M7 ONLY)

#### 3-2. DUAL POLE SERVO CIRCUIT

\*For the description of the above circuit which is identical to Model AA-R22/32/42, see the service manual for AA-22-32/42.

#### 3-3. PROTECTION CIRCUIT (AM-M7)

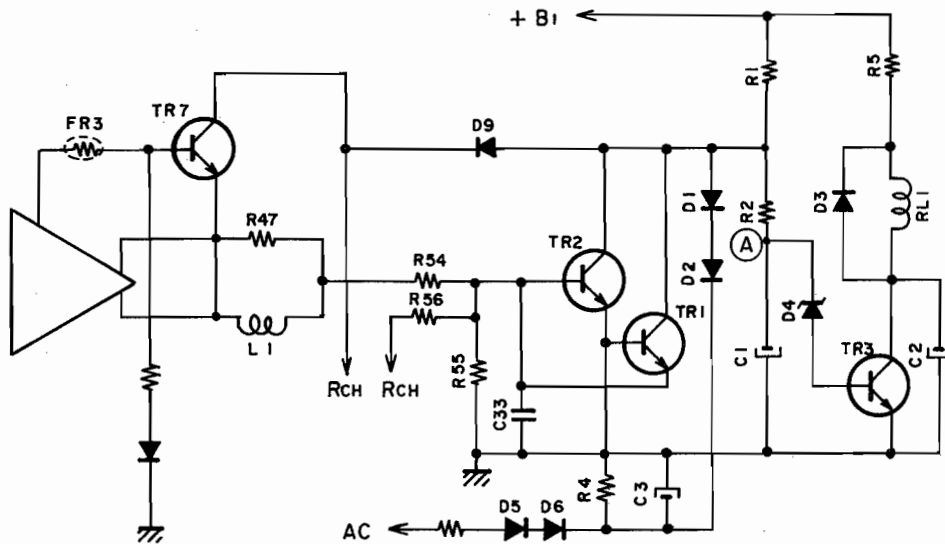

Fig. 3-1 Protection Circuit

##### 3-3-1. WHEN POWER IS ON

+B<sub>1</sub> and AC are both supplied to the protection circuit, then C<sub>1</sub> is charged through R<sub>1</sub> and R<sub>2</sub>, TR<sub>3</sub> is turned ON, and the relay (RL<sub>1</sub>) is turned ON.

##### 3-3-2. WHEN POWER IS OFF

The AC supplied when the power is ON is rectified by the diodes (D<sub>5</sub>, D<sub>6</sub>), which charges capacitor C<sub>3</sub>. When C<sub>3</sub> has discharged through R<sub>4</sub>, the voltage at point (A) drops because the diodes (D<sub>1</sub>, D<sub>2</sub>) conduct, then the transistor (TR<sub>3</sub>) is turned OFF, and the relay (RL<sub>1</sub>) is also turned OFF.

##### 3-3-3. SHOULD A DC VOLTAGE OCCUR AT THE MAIN AMPLIFIER OUTPUT

Should a (+) DC voltage occur at the output, the transistor (TR<sub>2</sub>) is turned ON through R<sub>54</sub>, and so the voltage at point (A) drops and the transistor (TR<sub>3</sub>) is turned OFF which turns the relay (RL<sub>1</sub>) OFF.

Should a (-) DC voltage occur at the output, the transistor (TR<sub>1</sub>) is turned ON through R<sub>54</sub>, and so the voltage at point (A) drops, the transistor (TR<sub>3</sub>) is turned OFF and the relay (RL<sub>1</sub>) is turned OFF to protect the speaker.

##### 3-3-4. OVERLOAD, OUTPUT TERMINAL SHORTED CONDITIONS

When excess current runs through the power amplifier IC (IC<sub>6</sub>), the transistor (TR<sub>7</sub>) is turned ON, the voltage at point (A) drops because the diode (D<sub>9</sub>) conducts, the transistor (TR<sub>3</sub>) is turned OFF, and the relay (RL<sub>1</sub>) is turned OFF.

## IV. POWER MUTE CIRCUIT

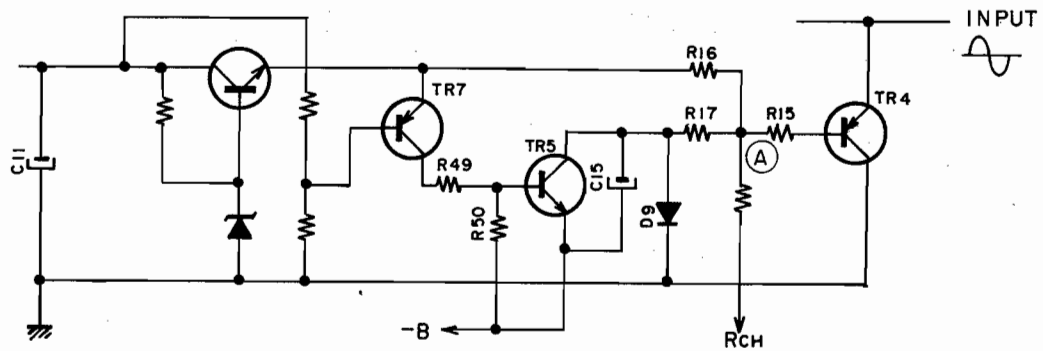

Fig. 4-1 Power Mute Circuit

### 4-1. WHEN POWER IS ON

When the power is turned ON, the voltage is supplied to the POWER MUTE Circuit and C15 is charged through R16 and R17, during which time the point (A) is negative since one end of Capacitor C15 is connected to -B. Therefore the transistor (TR4) is turned ON, so the input of the main amplifier circuit is grounded to create the mute state. When the capacitor (C15) is completely charged the voltage at point (A) becomes positive, the transistor (TR4) is turned OFF and the mute is released.

### 4-2. WHEN POWER IS OFF

When the power is turned OFF, the base potential for the transistor (TR7) drops to turn it ON, and the transistor (TR5) is turned ON, the voltage at the point (A) becomes negative, the transistor (TR4) is turned ON and the mute state is created.

## V. AUTO FUNCTION CONTROL

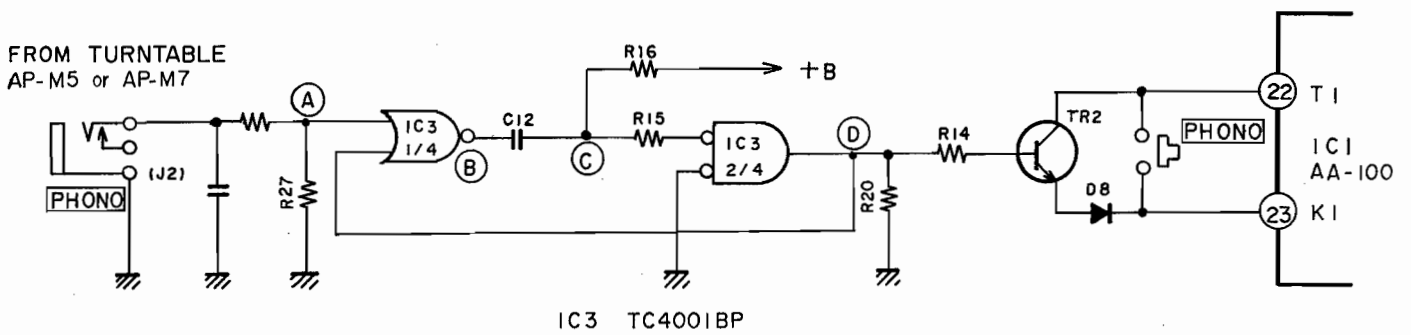

Fig. 5-1 Auto Function Circuit (indicates only PHONO Circuit)

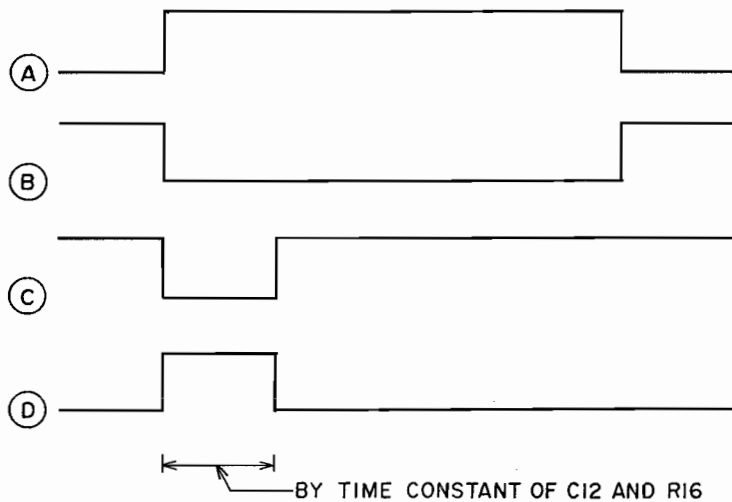
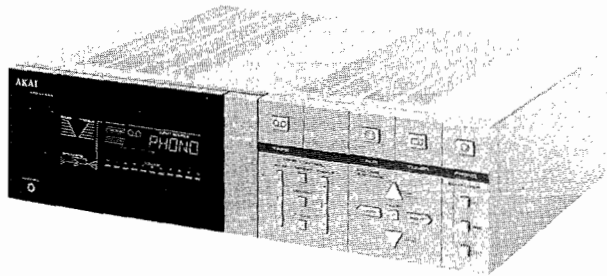
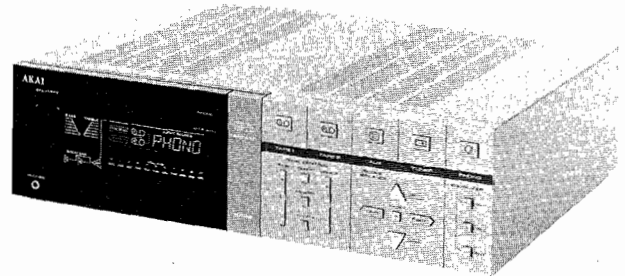

Fig. 5-2 Waveform at Each Points

When an AP-M5 or AP-M7 turntable is connected and operated, a control signal as shown in Fig. 5-2 (A) is input to the auto-function control jack (J2) shown in Fig. 5-1, and the waveform of (D) in Fig. 5-2 is created by the monostable multivibrator formed by IC3 (TC4001). When the waveform of (D) is at "H" level, TR2 is turned ON and the timing pulse from the pin (22) of IC1 AA-100 is received by Key Input K1 at pin (23). This means IC1 AA-100 is put into the PHONO mode.



AM-M5



AM-M7

SECTION 3

**SERVICE MANUAL**

**MODEL AM-M5/M7**

TABLE OF CONTENTS

<b>I. SPECIFICATIONS</b> .....	36
1. MODEL AM-M5 .....	36
2. MODEL AM-M7 .....	37
<b>II. DISMANTLING OF UNIT</b> .....	38
<b>III. CONTROLS</b> .....	39
1. MODEL AM-M5 .....	39
2. MODEL AM-M7 .....	40
<b>IV. PRINCIPAL PARTS LOCATION</b> .....	41
1. MODEL AM-M5 .....	41
2. MODEL AM-M7 .....	42
<b>V. VOLTAGE CONVERSION</b> .....	43
<b>VI. CLASSIFICATION OF VARIOUS P.C BOARDS</b> .....	44
1. MODEL AM-M5 P.C BOARD TITLES AND IDENTIFICATION NUMBERS .....	44
2. MODEL AM-M7 P.C BOARD TITLES AND IDENTIFICATION NUMBERS .....	44
3. MODEL AM-M5 COMPOSITION OF VARIOUS P.C BOARDS .....	45
4. MODEL AM-M7 COMPOSITION OF VARIOUS P.C BOARDS .....	52

For basic adjustments, measuring methods, and operating principles, refer to GENERAL TECHNICAL MANUAL.

# I. SPECIFICATIONS

## 1-1. MODEL AM-M5

### POWER AMPLIFIER SECTION

RATED OUTPUT POWER (BOTH CHANNELS DRIVEN, AT 8 ohms)	30w + 30w (THD 0.05%, 20Hz to 20kHz) 40w + 40w (EIAJ 5%, 1kHz)
POWER BANDWIDTH (IHF -3dB, AT 8 ohms)	5Hz to 40kHz (THD 0.1%)
S/N (IHF A) PHONO	75dB
AUX	99dB
RESIDUAL NOISE (8 ohms)	0.5mV
CHANNEL SEPARATION (IHF 1kHz)	45dB
DAMPING FACTOR (1kHz, 8 ohms)	30dB
APPLICABLE SPEAKER IMPEDANCE	6 to 16 ohms (for Europe, USA, Canada and Australia) 4 to 16 ohms (for other countries)

### PRE AMPLIFIER SECTION

INPUT SENSITIVITY/IMPEDANCE PHONO	2.5mV/100kohms
AUX	150mV/47kohms
TUNER	150mV/47kohms
TAPE	150mV/47kohms
OUTPUT LEVEL/IMPEDANCE TAPE REC	150mV/3kohms
FREQUENCY RESPONSE	
PHONO (RIAA DEVIATION)	±0.5dB (20Hz to 20kHz)
TUNER, AUX, TAPE	5Hz to 80kHz +0dB, -3dB
TONE CONTROL BASS	±8dB (100 kHz)
TREBLE	±8dB (10kHz)
POWER REQUIREMENTS	100V, 50/60Hz for Japan 120V, 60Hz for USA and Canada 220V, 50Hz for Europe except UK 240V, 50Hz for UK and Australia 110V/120V/220V/240V, 50Hz/60Hz Switchable for other countries
POWER CONSUMPTION	J: 100W U: 140W C, A: 105W
DIMENSIONS	350 (W) × 98 (H) × 267 (D) mm (13.8 × 3.9 × 10.5 inches)
WEIGHT	5.1 kg (11.2 lbs)

\* For improvement purposes, specifications and design are subject to change without notice.

## 1-2. MODEL AM-M7

### POWER AMPLIFIER SECTION

RATED OUTPUT POWER (BOTH CHANNELS DRIVEN, AT 8 ohms)	45w + 45w (THD 0.02%, 20Hz to 20kHz) 65w + 65w (EIAJ 5% 1kHz)
POWER BANDWIDTH (IHF -3dB, at 8 ohms)	5Hz to 70kHz (THD 0.1%)
S/N (IHF A) PHONO	78dB (MM)
AUX	98dB
RESIDUAL NOISE (8 ohms)	0.5mV
CHANNEL SEPARATION (IHF 1kHz)	45dB
DAMPING FACTOR (1kHz, 8 ohms)	35
APPLICABLE SPEAKER IMPEDANCE	6 to 16 ohms (for Europe, USA, Canada and Australia) 4 to 16 ohms (for other countries)

### PRE AMPLIFIER SECTION

INPUT SENSITIVITY/IMPEDANCE PHONO MC	0.25mV/100 ohms
PHONO MM	2.5mV/100kohms
AUX	150mV/47kohms
TUNER	150mV/47kohms
TAPE	150mV/47kohms
OUTPUT LEVEL/IMPEDANCE TAPE REC	150mV/3kohms
FREQUENCY RESPONSE	
PHONO (RIAA DEVIATION)	±0.5dB (20Hz to 20kHz)
TUNER, AUX, TAPE	5Hz to 80kHz + 0dB, -3dB
TONE CONTROL BASS	±8dB (100Hz)
TREBLE	±8dB (10kHz)
POWER REQUIREMENTS	100V, 50/60Hz for Japan 120V, 60Hz for USA and Canada 220V, 50Hz for Europe except UK 240V, 50Hz for UK and Australia 110V/120V/220V/240V, 50Hz/60Hz Switchable for other countries
POWER CONSUMPTION	J: 140W U: 240W C, A: 190W
DIMENSIONS	350 (W) × 98 (H) × 267 (D) mm (13.8 × 3.9 × 10.5 inches)
WEIGHT	6.5kg (13.3 lbs)

\* For improvement purposes, specifications and design are subject to change without notice.



## II. DISMANTLING OF UNIT

In case of trouble, etc. necessitating dismantling, please dismantle in the order shown in the photographs. Reassemble in reverse order.

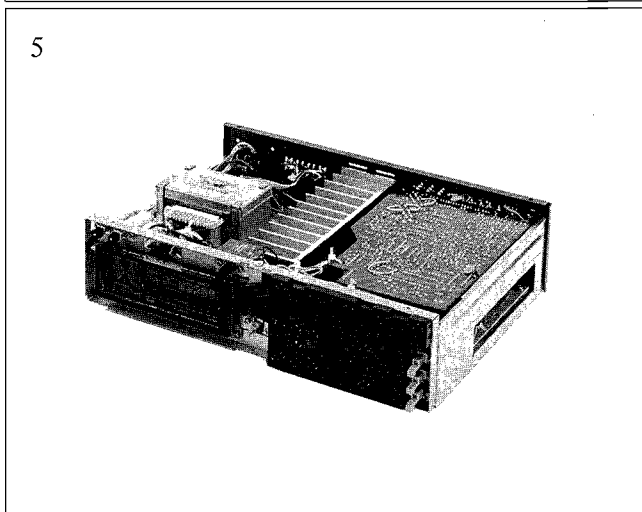
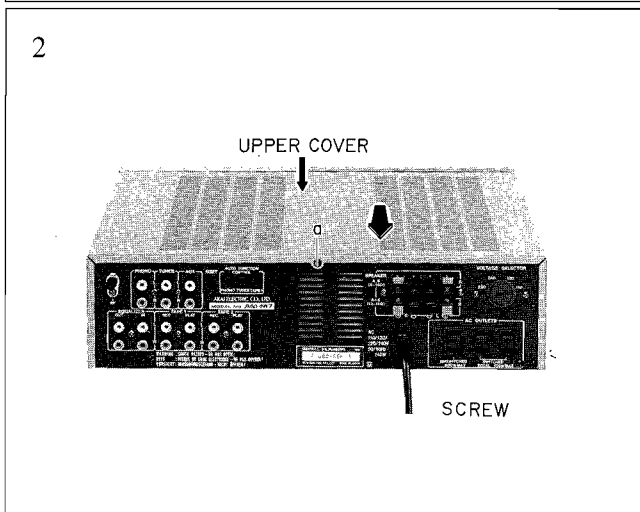
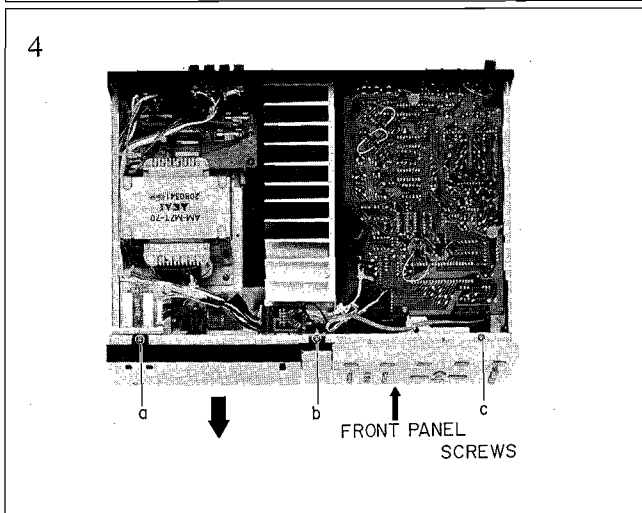
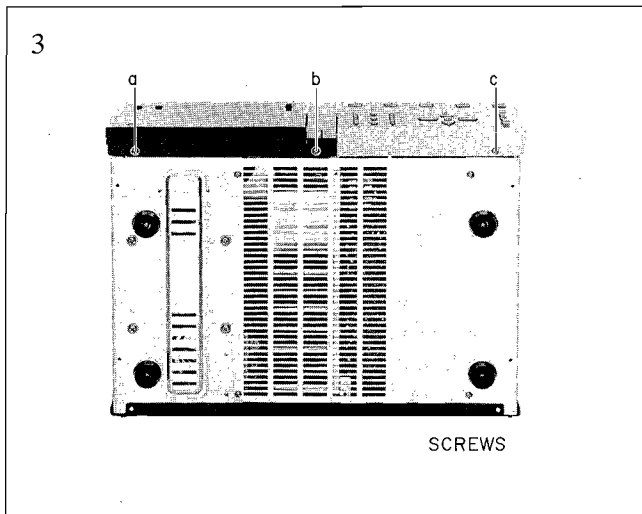
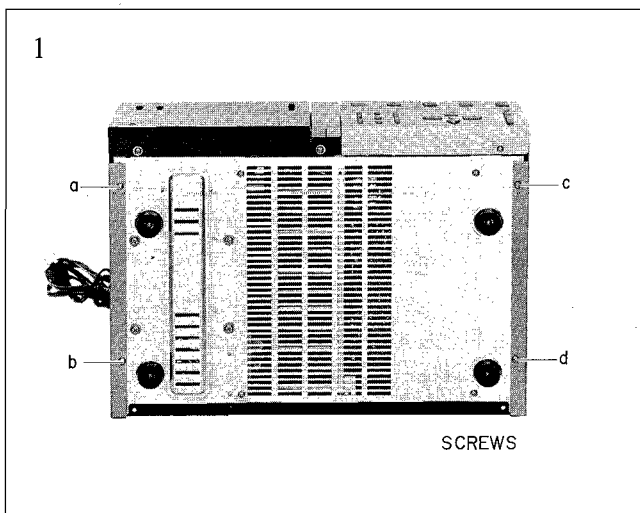

### III. CONTROLS

#### 3-1. MODEL AM-M5

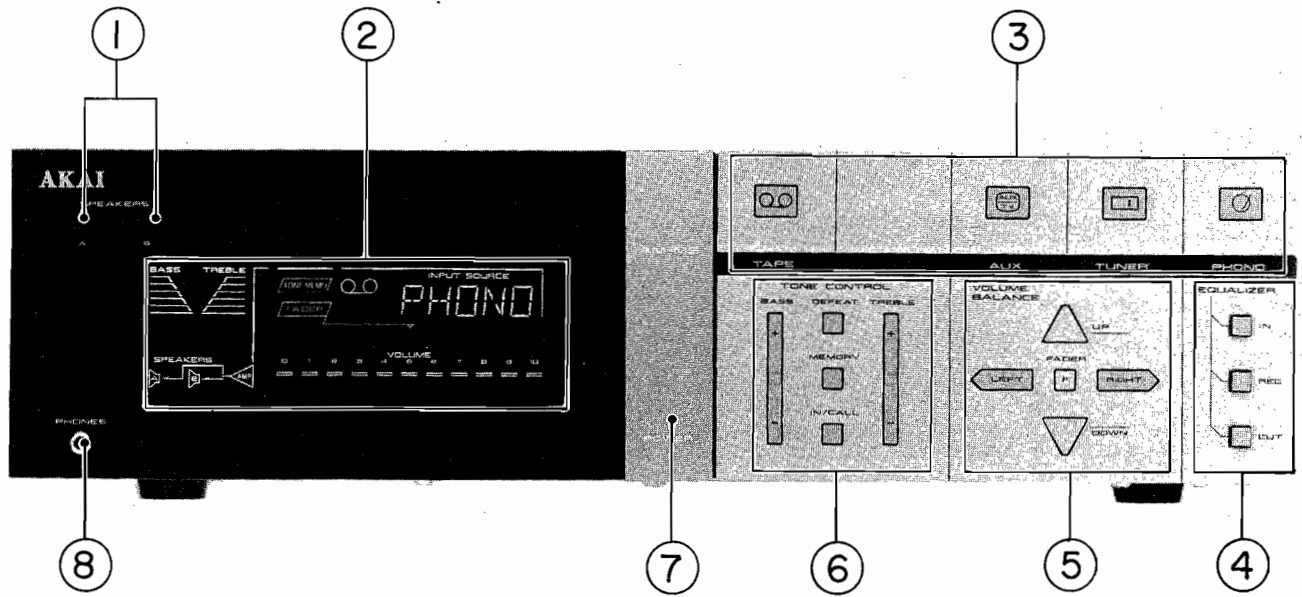

Fig. 3-1 Front View

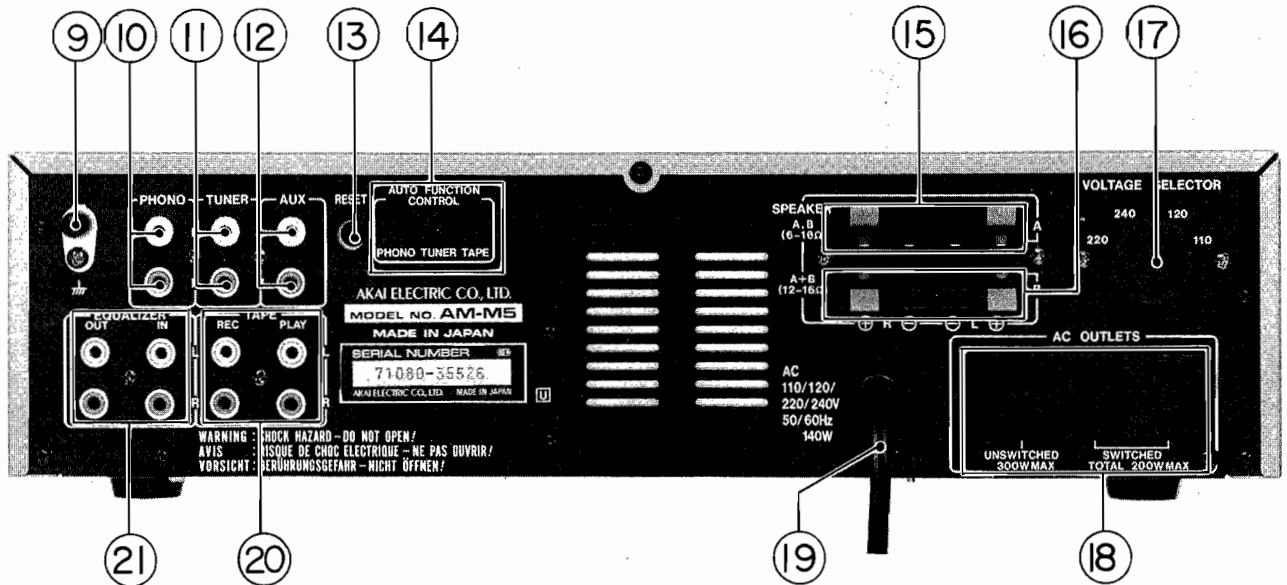

Fig. 3-2 Rear View

- |                                 |   |
|---------------------------------|---|
| 1. SPEAKER SELECTORS            | 12. AUX. JACKS                          |
| 2. FL DISPLAY                   | 13. RESET SWITCH                        |
| 3. INPUT SELECTOR               | 14. AUTO FUNCTION CONTROL JACKS         |
| 4. EQUALIZER IN/REC/CUT BUTTONS | 15. SPEAKER A TERMINAL                  |
| 5. VOLUME AND BALANCE CONTROLS  | 16. SPEAKER B TERMINAL                  |
| 6. TONE CONTROLS                | 17. VOLTAGE SELECTOR (U/T ONLY)         |
| 7. POWER SWITCH                 | 18. AC OUTLET (U/T, CSA, AAL, JPN ONLY) |
| 8. HEADPHONES                   | 19. AC CORD                             |
| 9. GROUND TERMINAL (⏏)          | 20. TAPE SYSTEM REC/PLAY JACKS          |
| 10. PHONO JACKS                 | 21. EQUALIZER IN/OUT JACKS              |
| 11. TUNER JACKS                 |   |

3-2. MODEL AM-M7

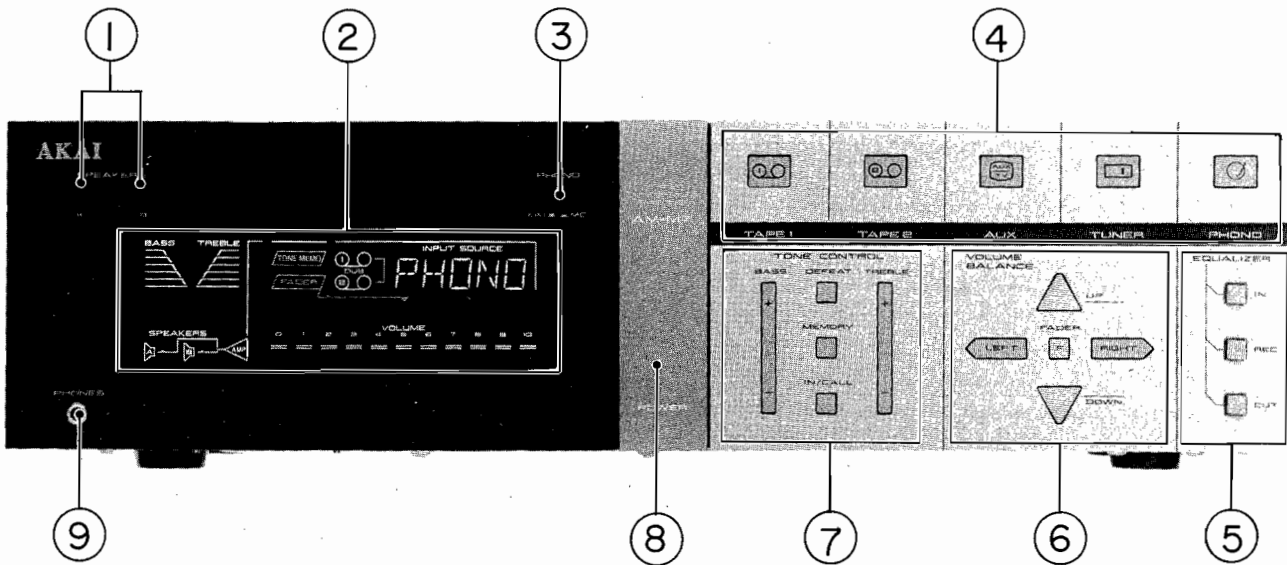

Fig. 3-3 Front View

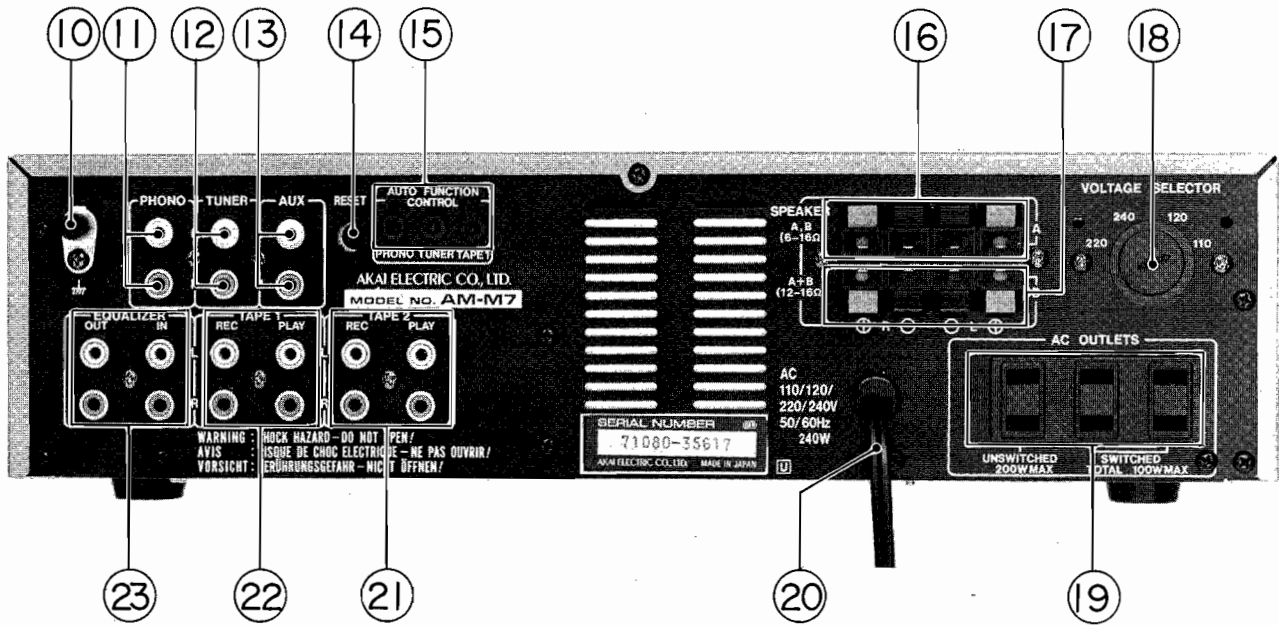

Fig. 3-4 Rear View

- |                                 |   |
|---------------------------------|---|
| 1. SPEAKER SELECTORS            | 13. AUX. JACKS                          |
| 2. FL DISPLAY                   | 14. RESET SWITCH                        |
| 3. CARTRIDGE SELECTOR           | 15. AUTO FUNCTION CONTROL JACKS         |
| 4. INPUT SOURCE SELECTOR        | 16. SPEAKER A TERMINAL                  |
| 5. EQUALIZER IN/REC/CUT BUTTONS | 17. SPEAKER B TERMINAL                  |
| 6. VOLUME AND BALANCE CONTROLS  | 18. VOLTAGE SELECTOR (U/T ONLY)         |
| 7. TONE CONTROLS                | 19. AC OUTLET (U/T, CSA, AAL, JPN ONLY) |
| 8. POWER SWITCH                 | 20. AC CORD                             |
| 9. HEADPHONE JACK               | 21. TAPE SYSTEM 2 REC/PLAY JACKS        |
| 10. GROUND TERMINAL (⏏)         | 22. TAPE SYSTEM 1 REC/PLAY JACKS        |
| 11. PHONO JACKS                 | 23. EQUALIZER IN/OUT JACKS              |
| 12. TUNER JACKS                 |   |

# IV. PRINCIPAL PARTS LOCATION

## 4-1. MODEL AM-M5

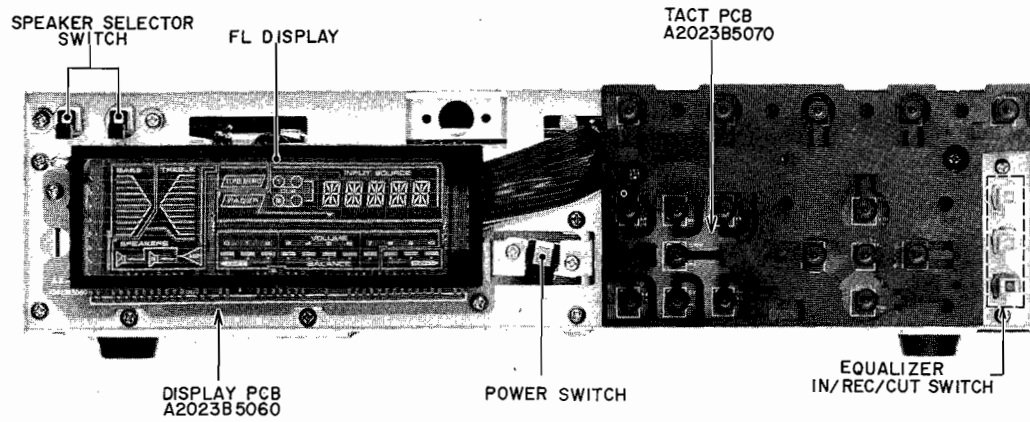

Fig. 4-1 Front View

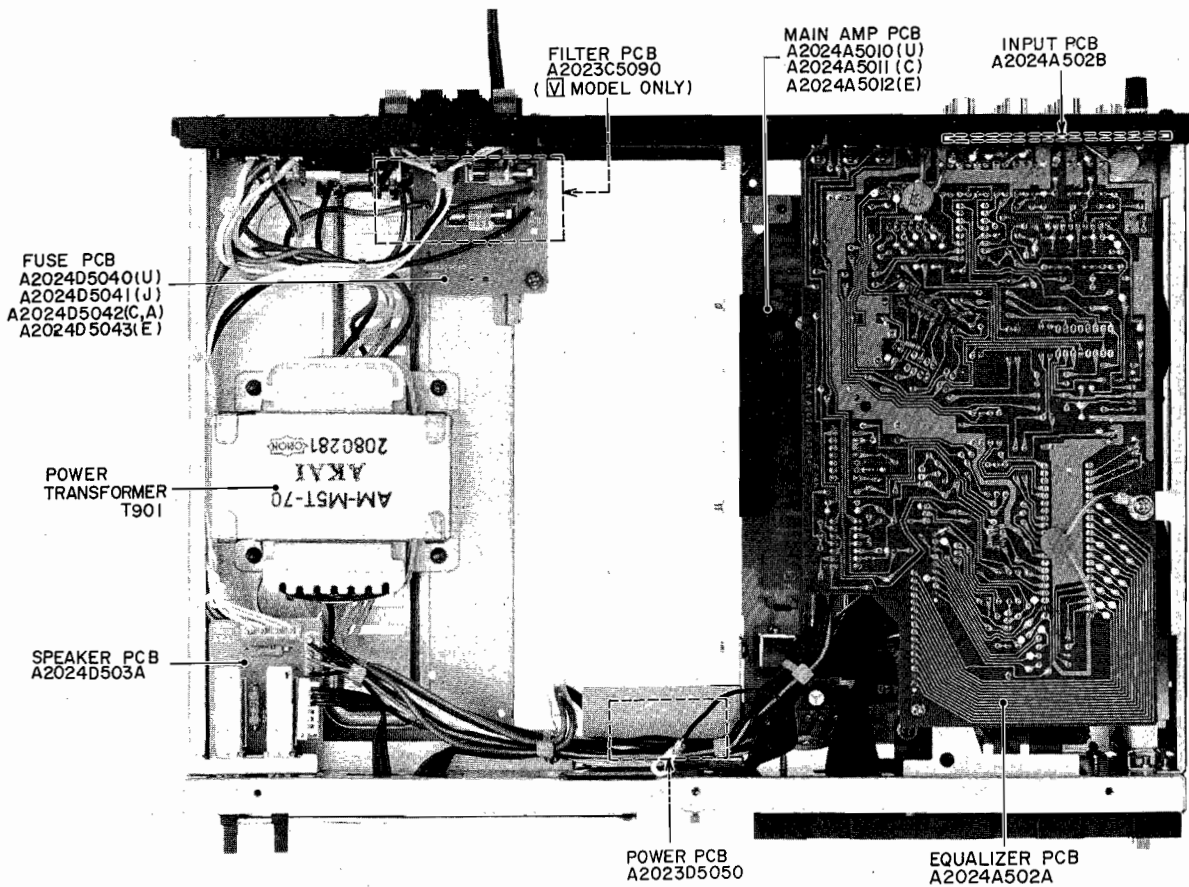

Fig. 4-2 Top View

4-2. MODEL AM-M7

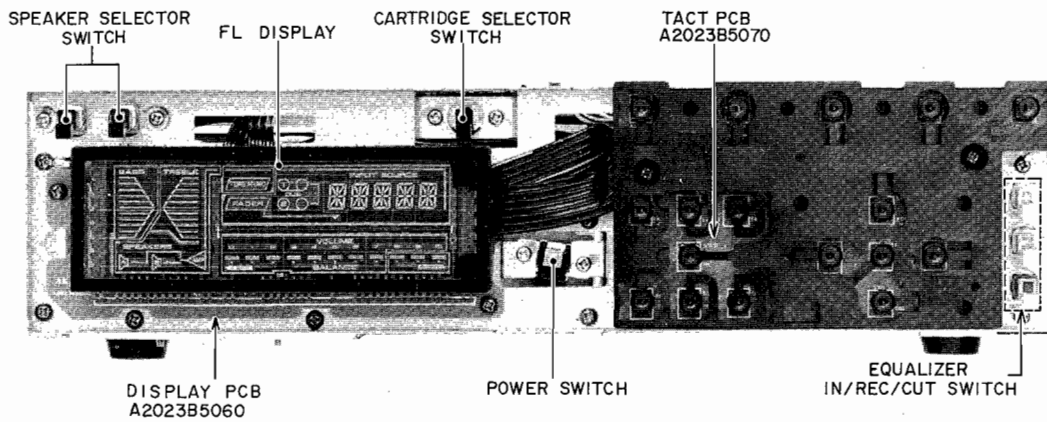

Fig. 4-3 Front View

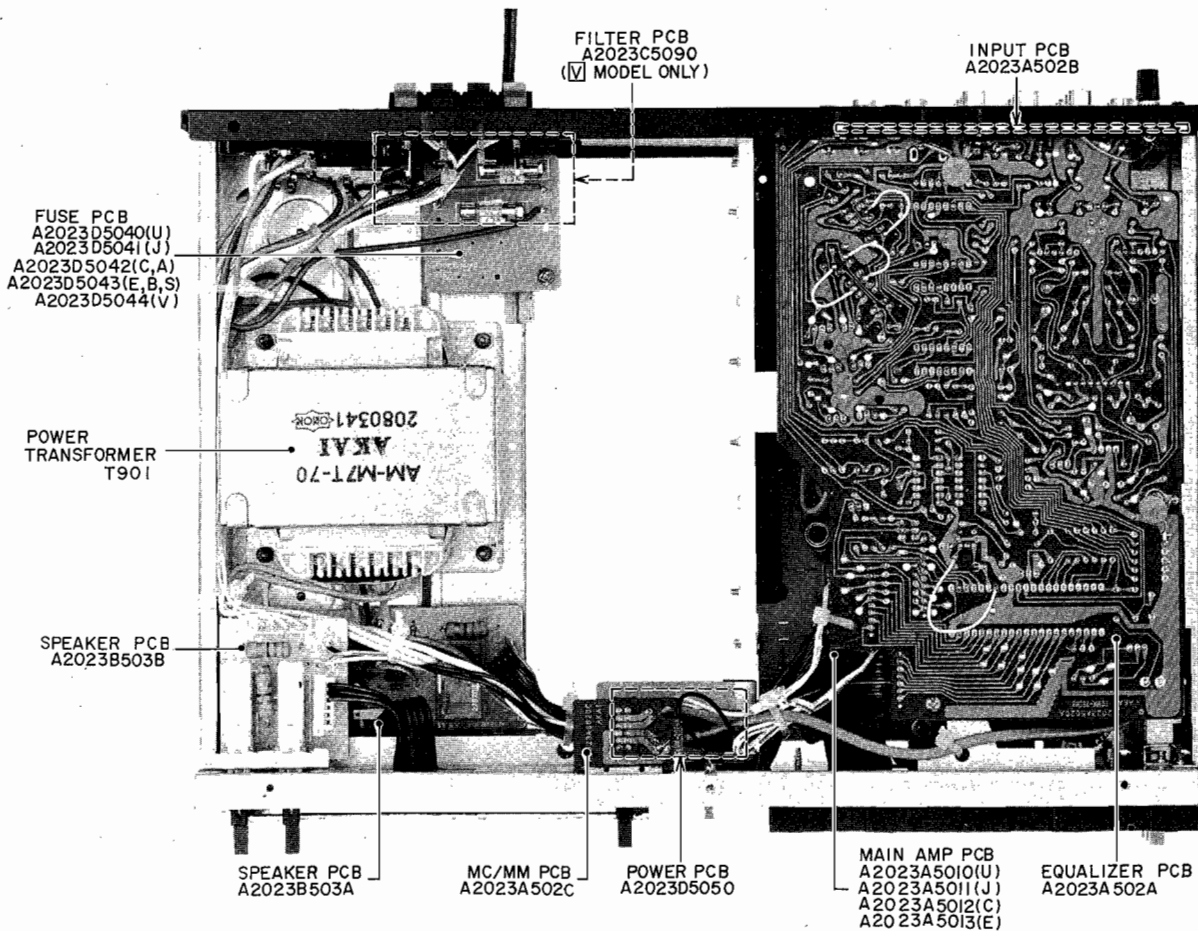

Fig. 4-4 Top View

## V. VOLTAGE CONVERSION

---

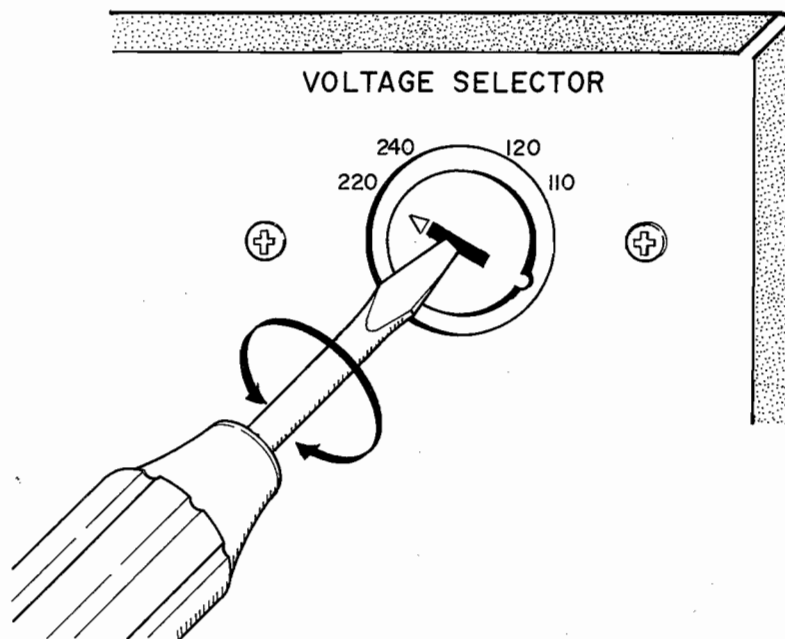

Fig. 5-1 Rear View

Models for Canada, USA, Europe, UK, Australia and Japan are not equipped with this facility. Each machine is present at the factory according to destination, but some machines can be set to 110V, 120V, 220V or 240V as required. If your machine is fitted with a voltage selector.

1. Disconnect the power cord.
2. Turn the **VOLTAGE SELECTOR** located on the rear panel with a screwdriver until the correct voltage is indicated.

## VI. CLASSIFICATION OF VARIOUS P.C BOARDS

### 6-1. MODEL AM-M5 P.C BOARD TITLES AND IDENTIFICATION NUMBERS

PCB		NO.	
MAIN-AMP	P.C Board	A2024A5010	U J
MAIN-AMP	P.C Board	A2024A5011	C A
MAIN-AMP	P.C Board	A2024A5012	E V B S
EQUALIZER	P.C Board	A2024A5020A	
INPUT	P.C Board	A2024A5020B	
DISPLAY	P.C Board	A2023B5060	
TACT	P.C Board	A2023B5070	
SPEAKER	P.C Board	A2024D503A	
HEAD PHONE	P.C Board	A2024D503B	
FILTER	P.C Board	A2023C5090	V only
FUSE	P.C Board	A2024D5040	U
FUSE	P.C Board	A2024D5041	J
FUSE	P.C Board	A2024D5042	C A
FUSE	P.C Board	A2024D5043	E B S
FUSE	P.C Board	A2024D5044	V
POWER	P.C Board	A2023D5050	

### 6-2. MODEL AM-M7 P.C BOARD TITLES AND IDENTIFICATION NUMBERS

PCB		NO.	
MAIN-AMP	P.C Board	A2023A5010	U
MAIN-AMP	P.C Board	A2023A5011	J
MAIN-AMP	P.C Board	A2023A5012	C A
MAIN-AMP	P.C Board	A2023A5013	E V B S
EQUALIZER	P.C Board	A2023A5020A	
INPUT	P.C Board	A2023A5020B	
MC/MM	P.C Board	A2023A5020C	
DISPLAY	P.C Board	A2023B5060	
TACT	P.C Board	A2023B5070	
SPEAKER	P.C Board	A2023B503A	
SPEAKER	P.C Board	A2023B503B	
SPEAKER	P.C Board	A2023B503C	
FILTER	P.C Board	A2023C5090	V only
FUSE	P.C Board	A2023D5040	U
FUSE	P.C Board	A2023D5041	J
FUSE	P.C Board	A2023D5042	C A
FUSE	P.C Board	A2023D5043	E B S
FUSE	P.C Board	A2023D5044	V
POWER	P.C Board	A2023D5050	

### 6-3. MODEL AM-M5 COMPOSITION OF VARIOUS P.C BOARDS

#### 1) MODEL AM-M5 MAIN-AMP P.C BOARD A2024A5010, 11, 12

WARNING:  $\Delta$  INDICATES SAFETY CRITICAL COMPONENTS FOR CONTINUED SAFETY, REPLACE SAFETY CRITICAL COMPONENTS ONLY WITH MANUFACTURER'S RECOMMENDED PARTS  
 AVERTISSEMENT:  $\Delta$  IL INDIQUE LES COMPOSANTS CRITIQUES DE SÉCURITÉ. POUR MAINTENIR LE DEGRÉ DE SÉCURITÉ DE L'APPAREIL, NE REMPLACER QUE DES PIÈCES RECOMMANDÉES PAR LE FABRICANT

#### LOCATION OF COMPONENTS

IC	TERMINAL
IC1---C3	J1 --- C3
IC2---B3	J2 --- A3
IC3---A3	J3 --- D1
IC4---A3	J4 --- B3
IC5---B1	①to⑤-D1
IC6---A2	⑥to⑨-B1

TR	
TR1---D3	
TR2,6---C3	
TR3---D1	
TR4---A2	
TR4b---B2	
TR5,7---C2	

TR1,TR3	--- 2SD612K(E,F)
TR2	--- 2SB632K(E,F)
TR4,TR4b	--- 2SA608K-NP(E,F)
TR7	--- 2SA608K-NP(E,F)
TR5,TR6	--- 2SC536K-NP(E,F)



2SD612K(E,F)  
2SB632K(E,F)

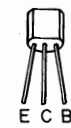

2SA608K-NP(E,F)  
2SC536K-NP(E,F)

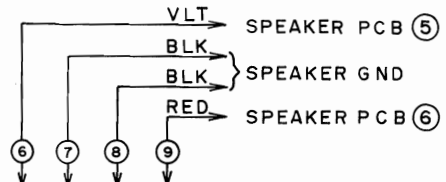
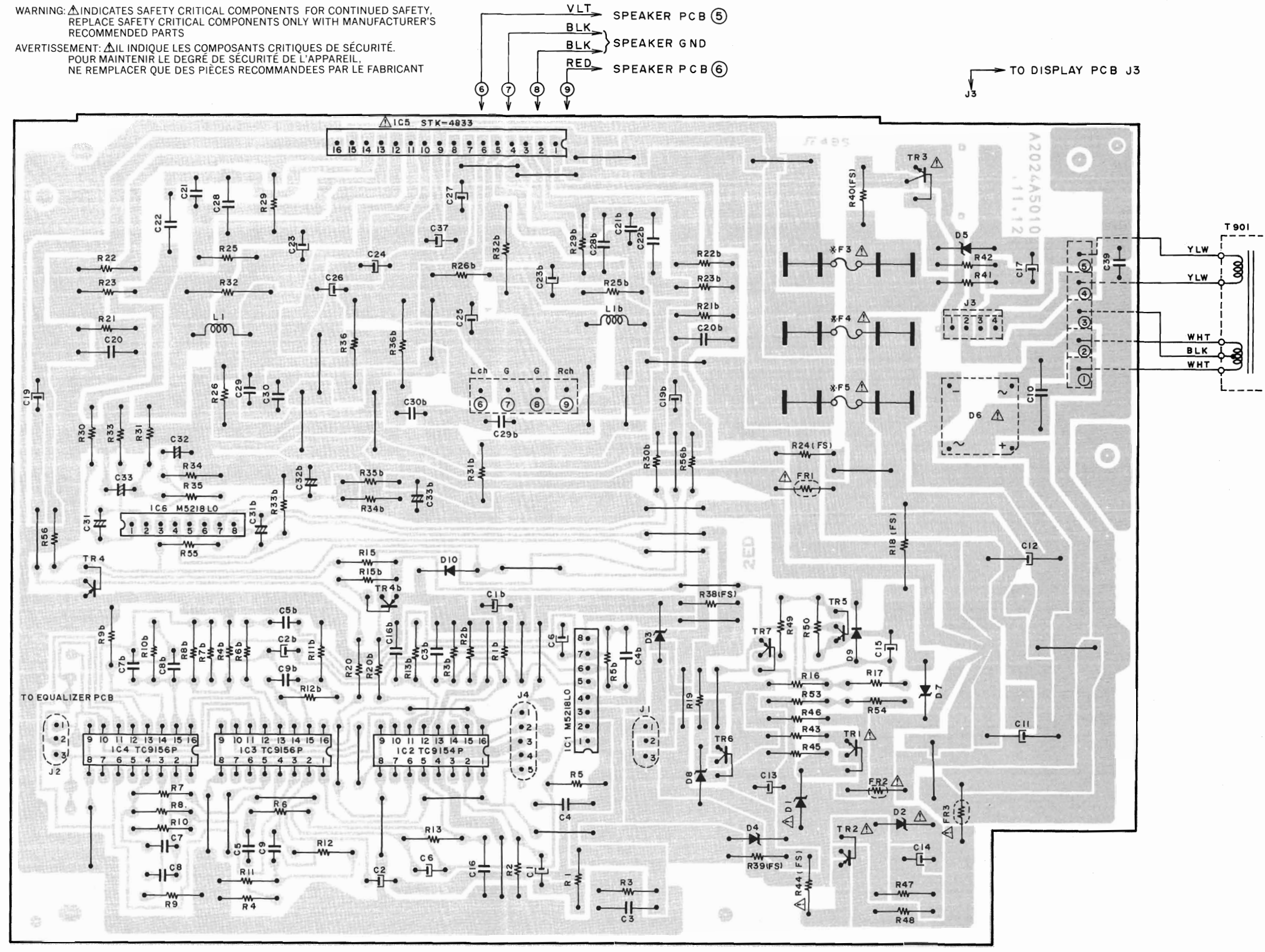

A2024 A5010  $\square$   $\square$   
 A2024 A5011  $\square$   $\square$   
 A2024 A5012  $\square$   $\square$   $\square$   $\square$

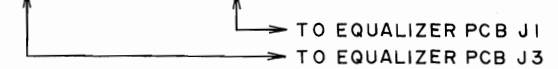

*	$\square$	$\square$	$\square$	$\square$	$\square$
F3	5A250V	5A250V	5A125V	T5A	
F4	2.5A250V	2.5A250V	2.5A125V	T2A	
F5	2.5A250V	2.5A250V	2.5A125V	T2A	



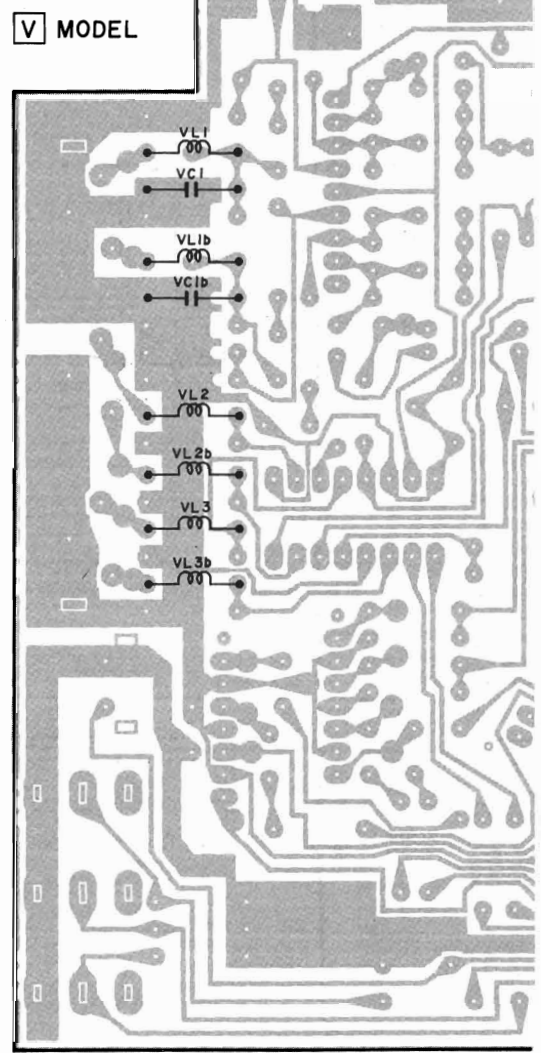
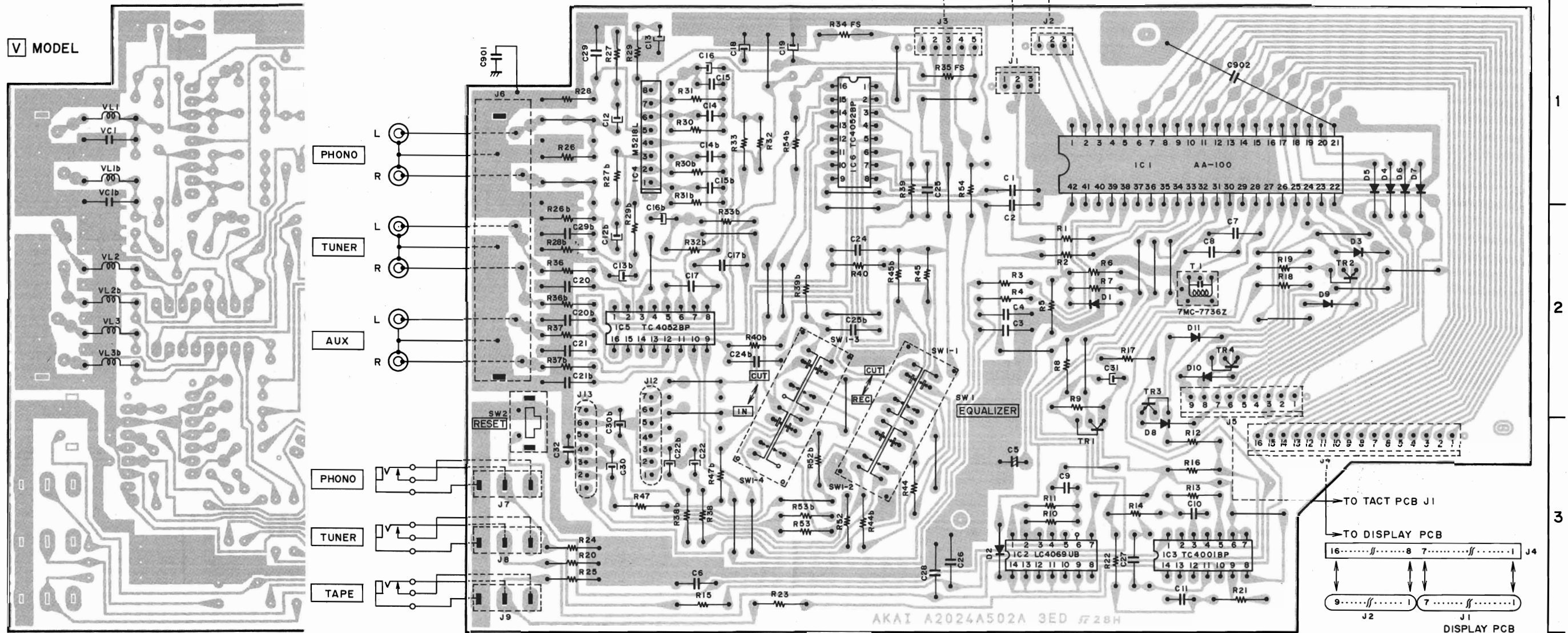

LOCATION OF COMPONENTS

IC	TERMINAL	TR
IC1	C1	J1, J2---C1
IC2	C3	J3---B1
IC3	C3	J4---D3
IC4	A1	J5---C2
IC5	A2	J6---A1,2
IC6	B1	J7 to J11---A3

TR	TERMINAL
TR1	C3
TR2	D2
TR3	C2
TR4	C2

TR1 to TR4---2SC536K-NP(E.F)



EQUALIZER PCB A2024A502A

3) MODEL AM-M5 DISPLAY P.C BOARD A2023B5060

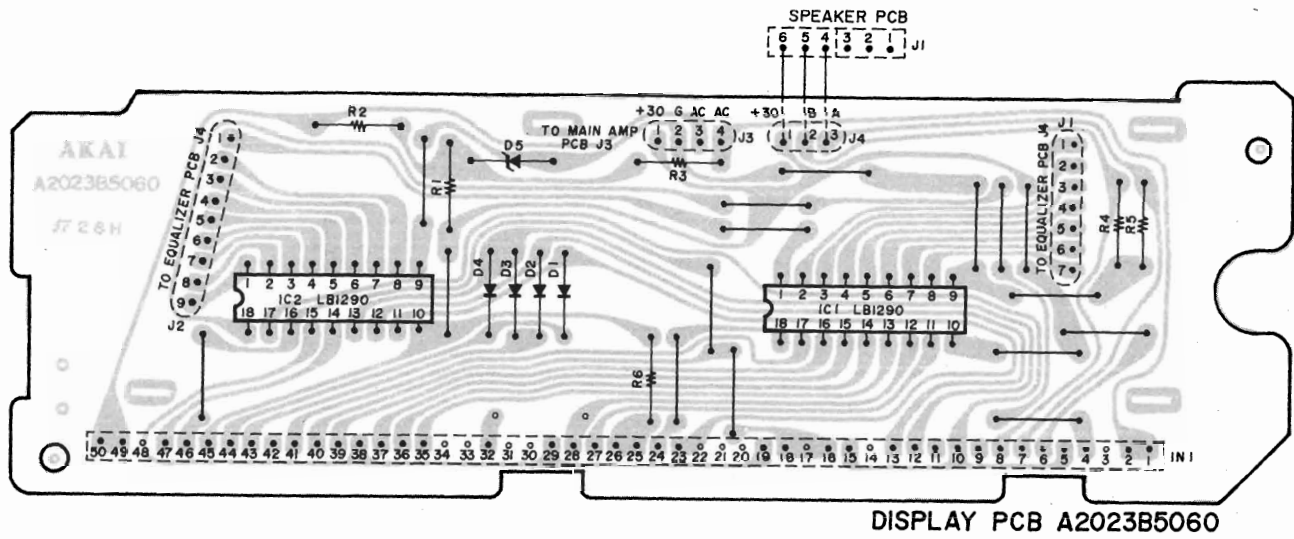

4) MODEL AM-M5 INPUT P.C BOARD A2024A5020B

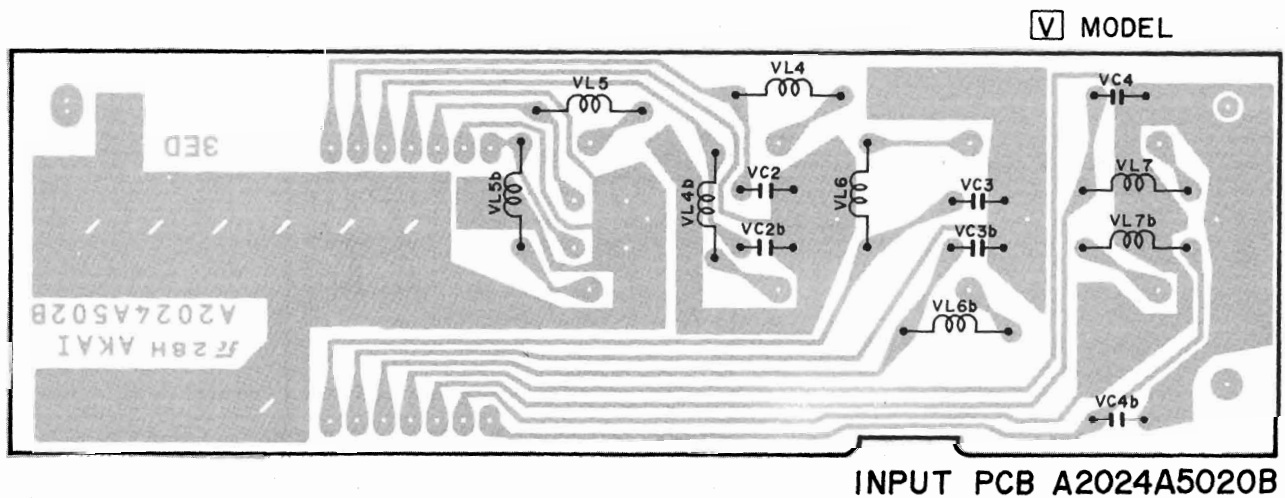
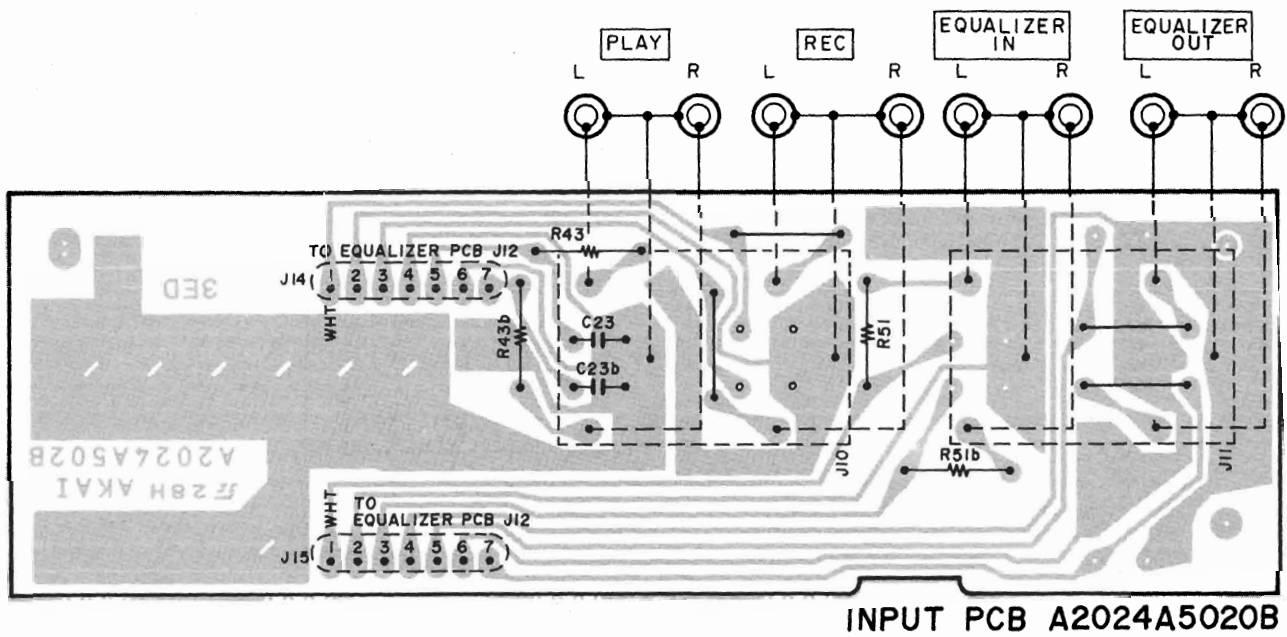

5) MODEL AM-M5 TACT P.C BOARD A2023B5070

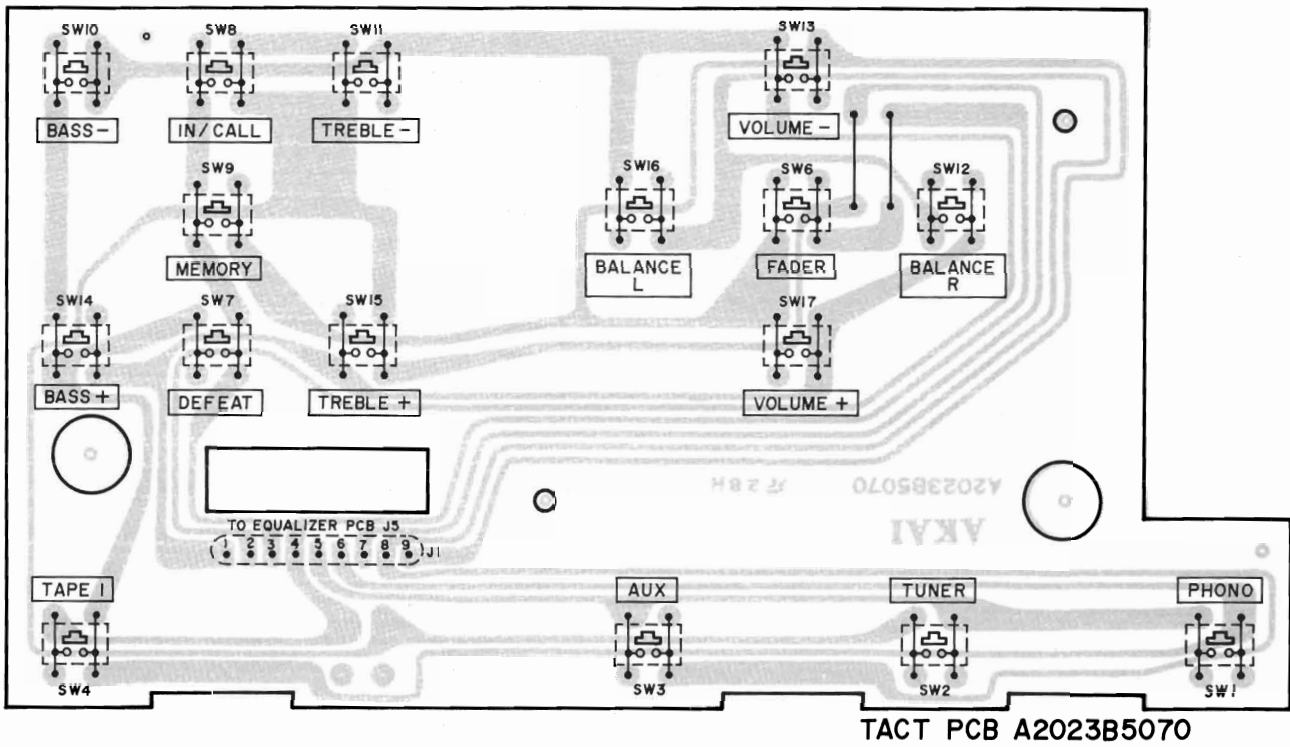

6) MODEL AM-M5 SPEAKER P.C BOARD A2024D503A

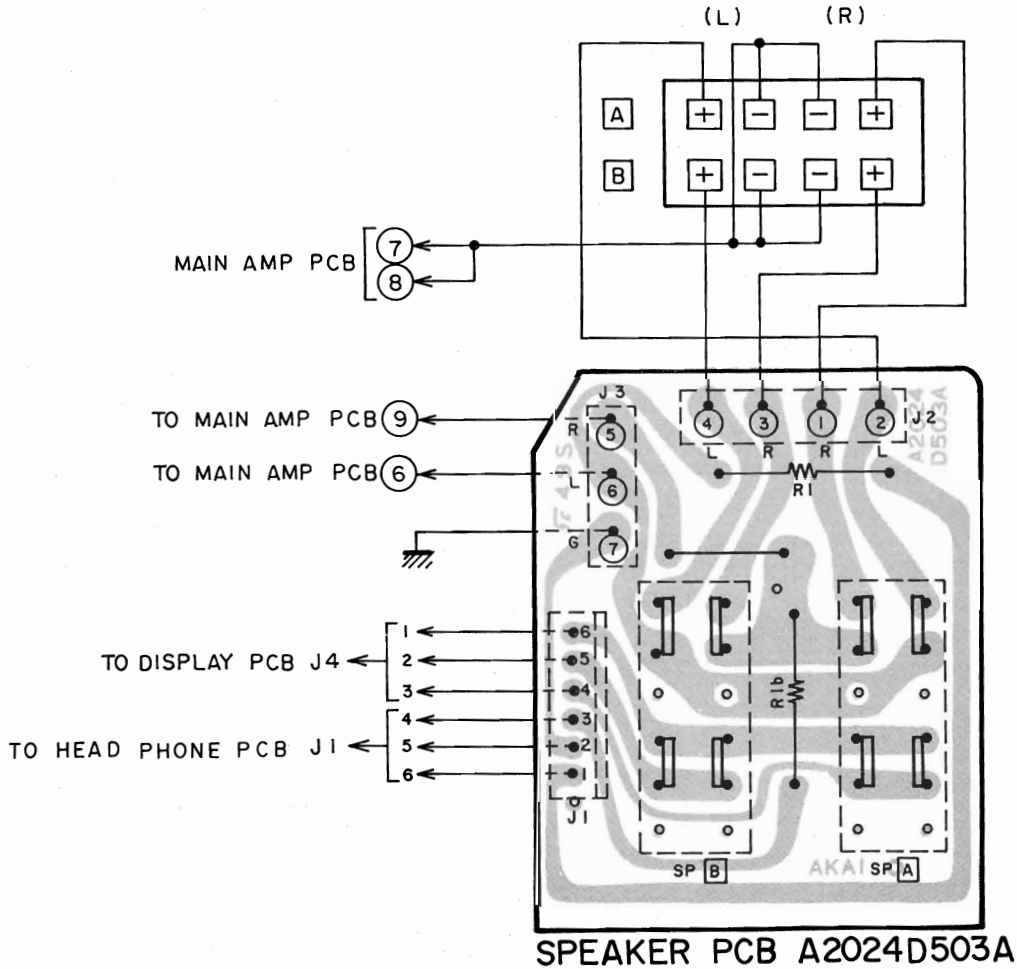

7) MODEL AM-M5 HEAD PHONE P.C BOARD A2024D503B

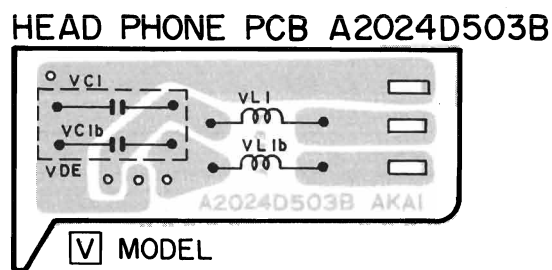
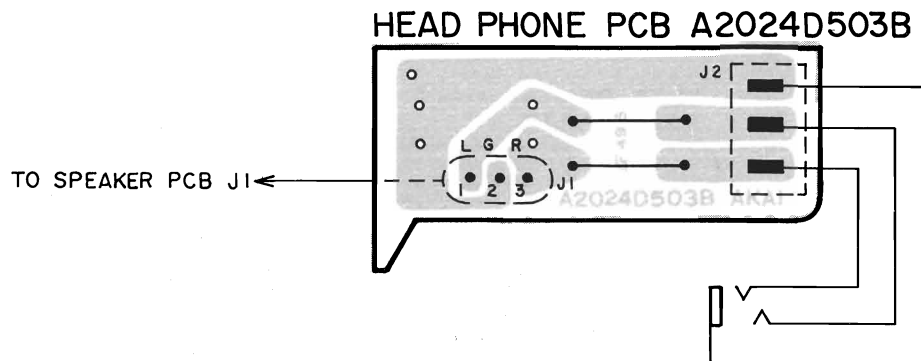

8) MODEL AM-M5 FILTER P.C BOARD A2023C5090

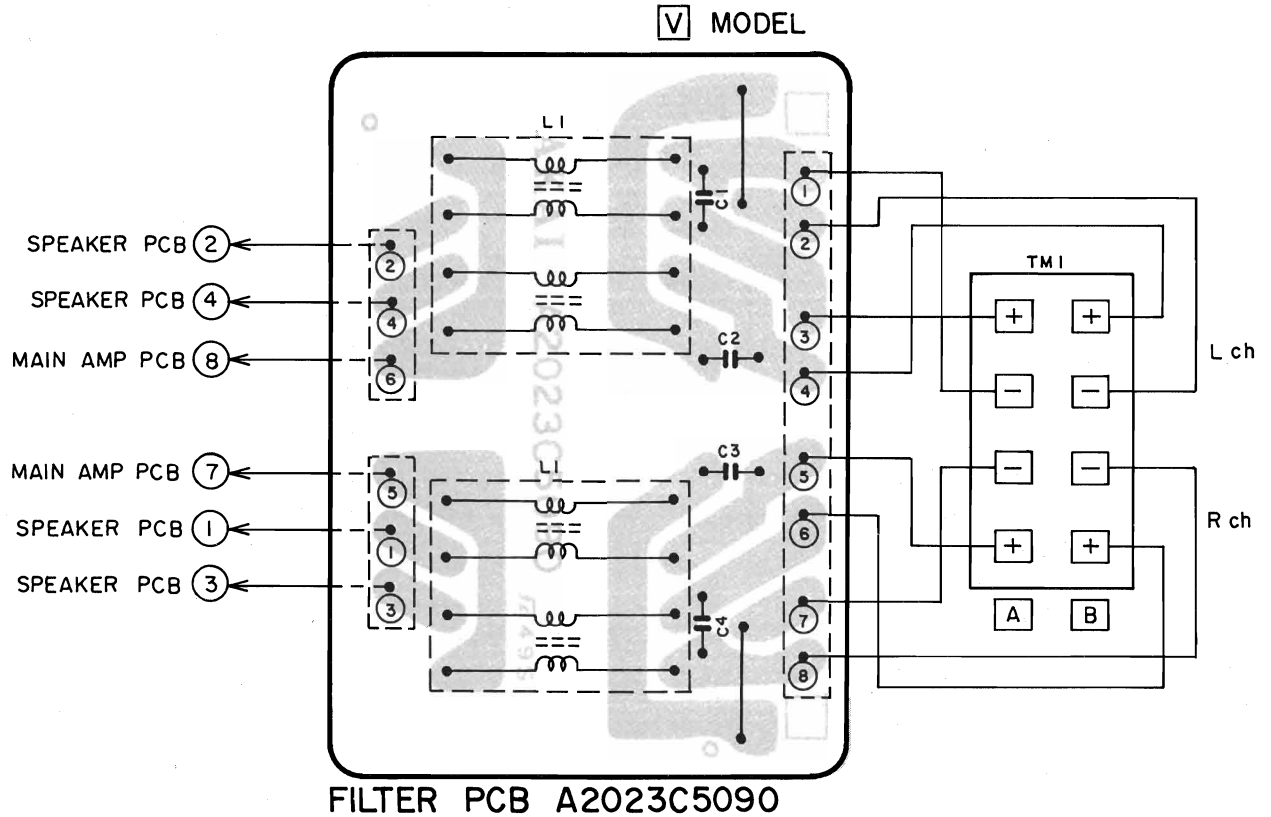

9) MODEL AM-M5 FUSE P.C BOARD A2024D5040

POWER P.C BOARD A2023D5050

U

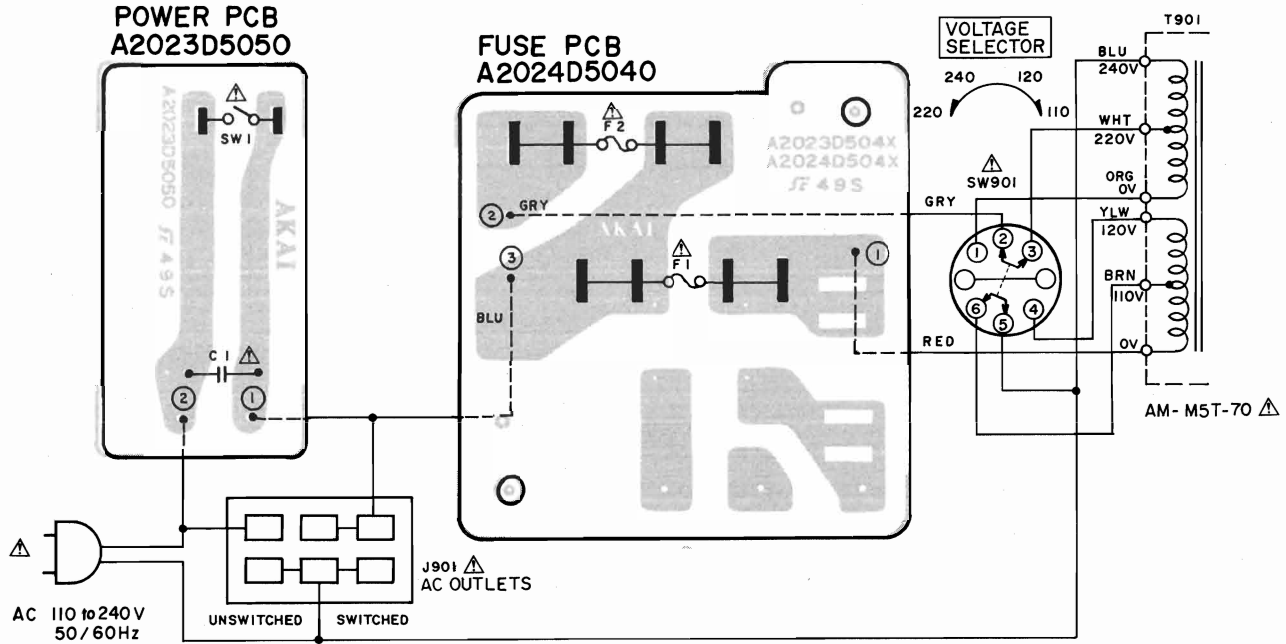

10) MODEL AM-M5 FUSE P.C BOARD A2024D5041, 42

POWER P.C BOARD A2023D5050

J, A, C

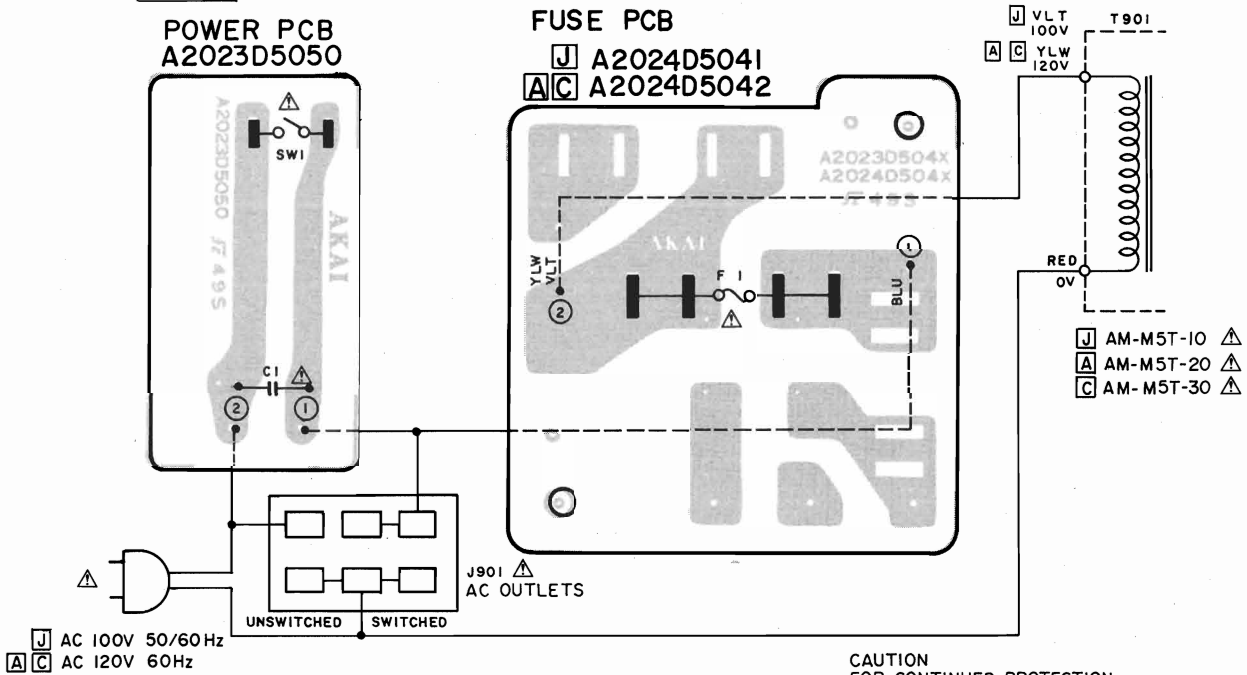

CAUTION  
FOR CONTINUED PROTECTION  
AGAINST FIRE HAZARD REPLACE  
ONLY WITH SAM TYPE FUSE.

WARNING: Δ INDICATES SAFETY CRITICAL COMPONENTS. FOR CONTINUED SAFETY, REPLACE SAFETY CRITICAL COMPONENTS ONLY WITH MANUFACTURER'S RECOMMENDED PARTS.  
AVERTISSEMENT: Δ IL INDIQUE LES COMPOSANTS CRITIQUES DE SÛRETÉ. POUR MAINTENIR LE DEGRÉ DE SÛRETÉ DE L'APPAREIL NE REMPLACER LES COMPOSANTS DONT LE FONCTIONNEMENT EST CRITIQUE POUR LA SÛRETÉ QUE PAR DES PIÈCES RECOMMANDÉES PAR LE FABRICANT.

11) MODEL AM-M5 FUSE P.C BOARD A2024D5043 POWER P.C BOARD A2023D5050

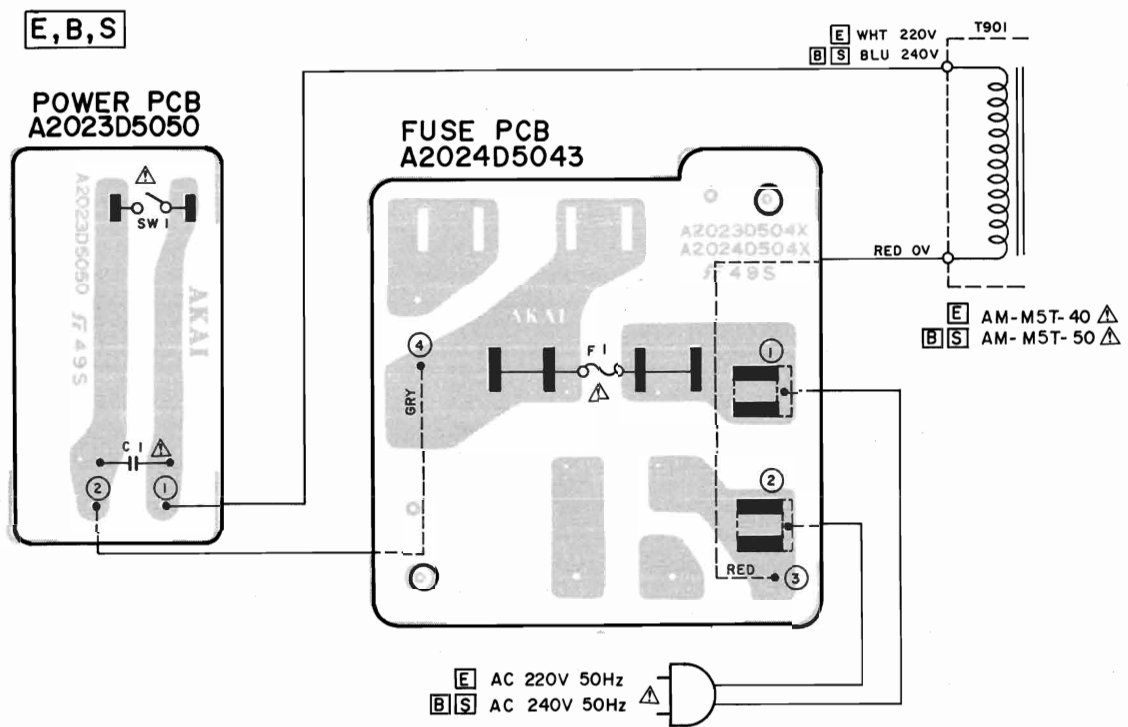

12) MODEL AM-M5 FUSE P.C BOARD A2024D5044 POWER P.C BOARD A2023D5050

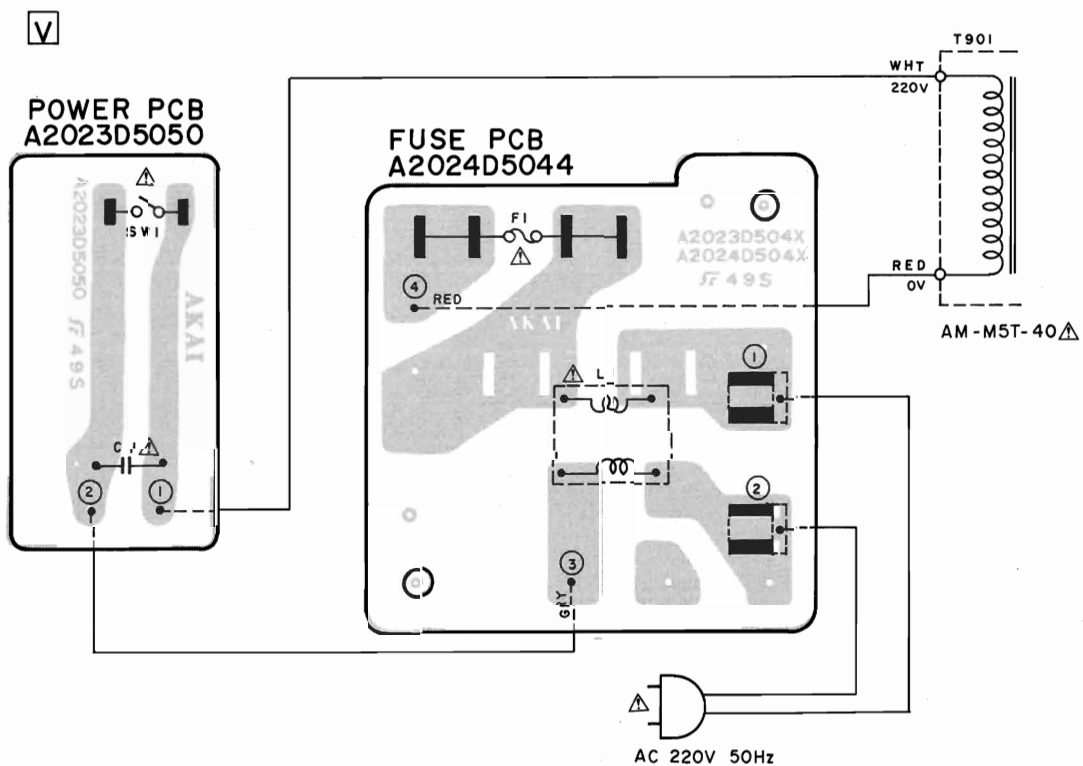

WARNING:  $\Delta$  INDICATES SAFETY CRITICAL COMPONENTS FOR CONTINUED SAFETY.  
REPLACE SAFETY CRITICAL COMPONENTS ONLY WITH MANUFACTURER'S  
RECOMMENDED PARTS

AVERTISSEMENT:  $\Delta$  IL INDIQUE LES COMPOSANTS CRITIQUES DE SÉCURITÉ.  
POUR MAINTENIR LE DEGRÉ DE SÉCURITÉ DE L'APPAREIL,  
NE REMPLACER QUE DES PIÈCES RECOMMANDÉES PAR LE FABRICANT

### 6-4. MODEL AM-M7 COMPOSITION OF VARIOUS P.C BOARDS

#### 1) MODEL AM-M7 MAIN-AMP P.C BOARD A2023A5010, 11, 12, 13

##### LOCATION OF COMPONENTS

###### IC

- IC 1 ----- B 1
- IC 2 ----- D 1
- IC 3, 4 ----- C 1
- IC 5 ----- C 2
- IC 6 ----- B 3
- IC 6b ----- D 3
- IC 7 ----- C 3

###### TR

- TR 1,2 ----- A 1
- TR 3 ----- A 2
- TR 4 to TR 6 ----- B 2
- TR 4b to TR 6b ----- D 2
- TR 7 ----- B 3
- TR 7b ----- C 3

###### TERMINAL

- J 1 ----- D 1
- J 2 ----- B 1
- J 3 ----- C 1
- J 4 ----- B 2, 3
- ① to ③ ----- A 3
- ⑥, ⑦ ----- B 3

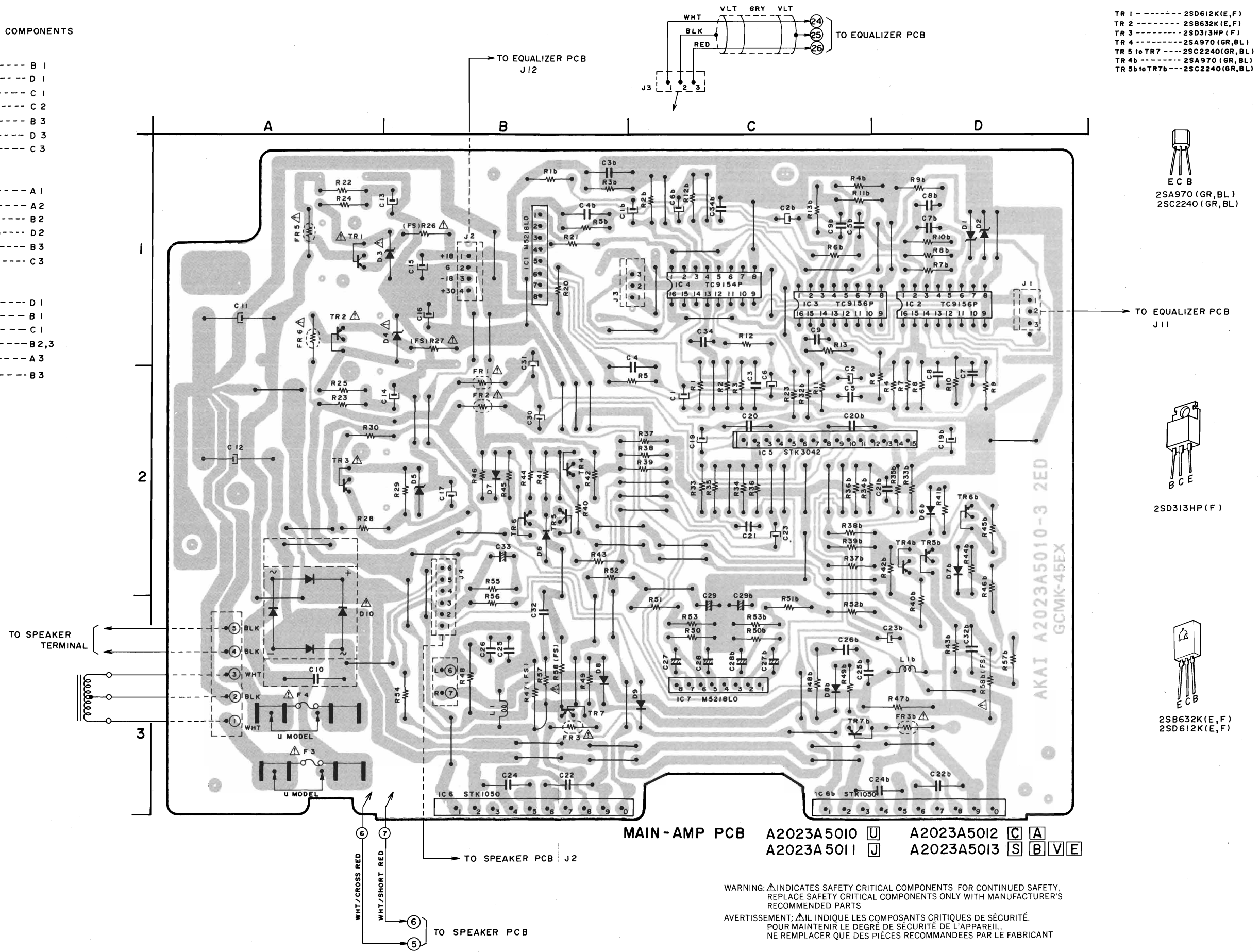

- TR 1 ----- 2SD612K(E,F)
- TR 2 ----- 2SB632K(E,F)
- TR 3 ----- 2SD313HP(F)
- TR 4 ----- 2SA970(GR,BL)
- TR 5 to TR 7 ----- 2SC2240(GR,BL)
- TR 4b ----- 2SA970(GR,BL)
- TR 5b to TR 7b ----- 2SC2240(GR,BL)

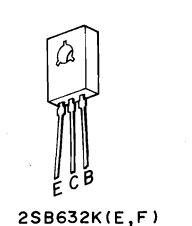
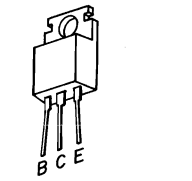
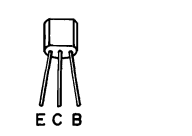

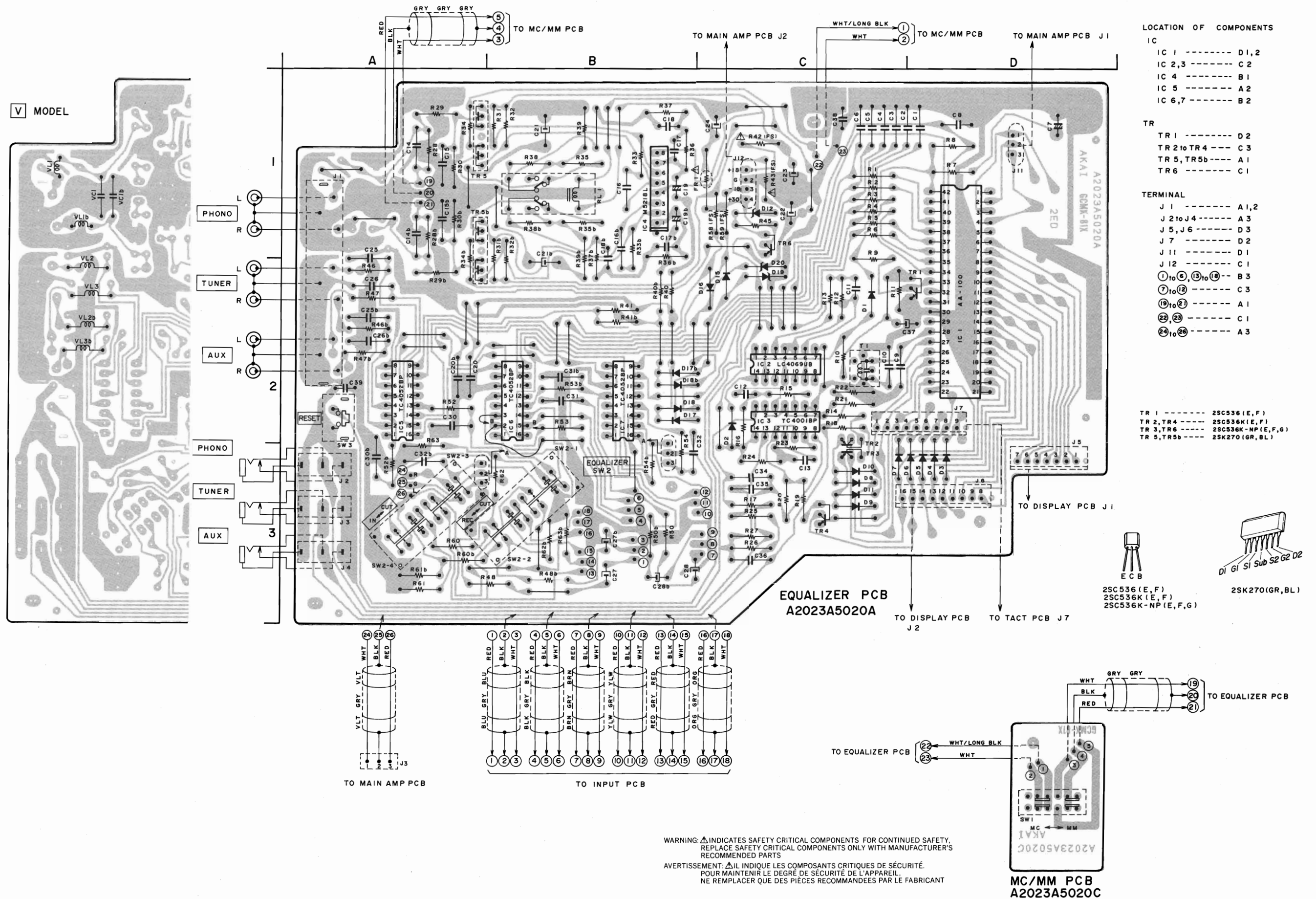



3) MODEL AM-M7 INPUT P.C BOARD A2023A5020B

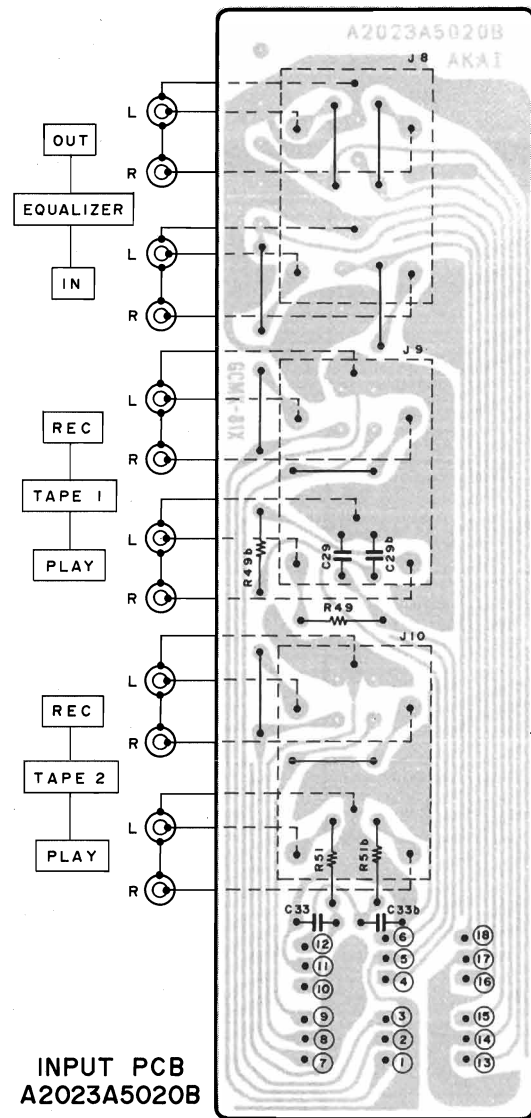

INPUT PCB  
A2023A5020B

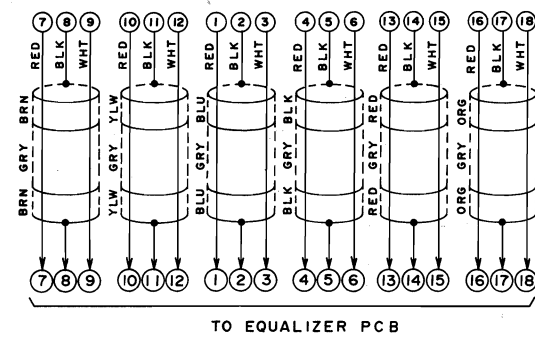

TO EQUALIZER PCB

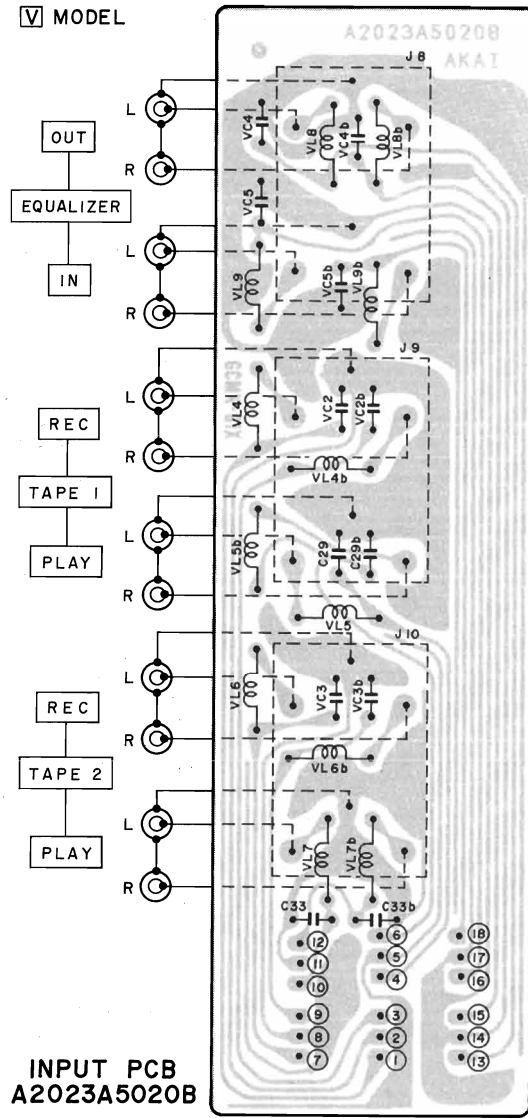

INPUT PCB  
A2023A5020B

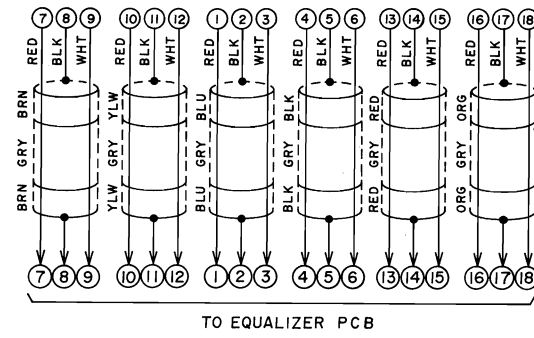

TO EQUALIZER PCB

4) MODEL AM-M7 DISPLAY P.C BOARD A2023B5060

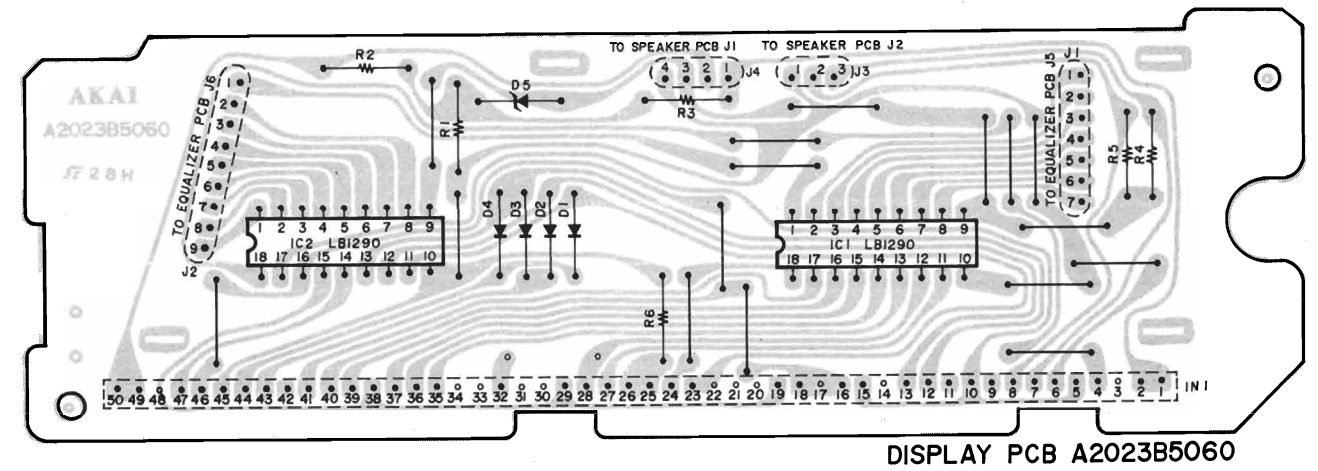

DISPLAY PCB A2023B5060

5) MODEL AM-M7 TACT P.C BOARD A2023B5070

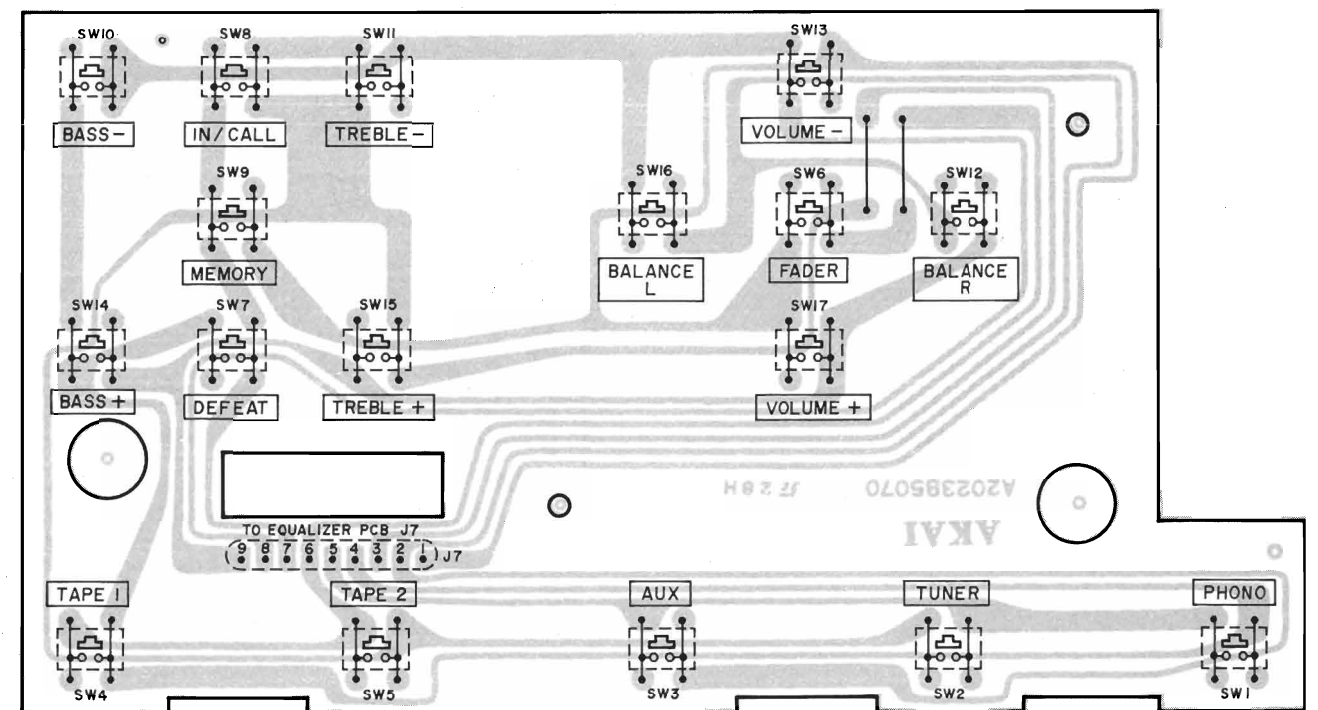

TACT PCB A2023B5070

6) MODEL AM-M7 SPEAKER P.C BOARD A2023B503A, B, C

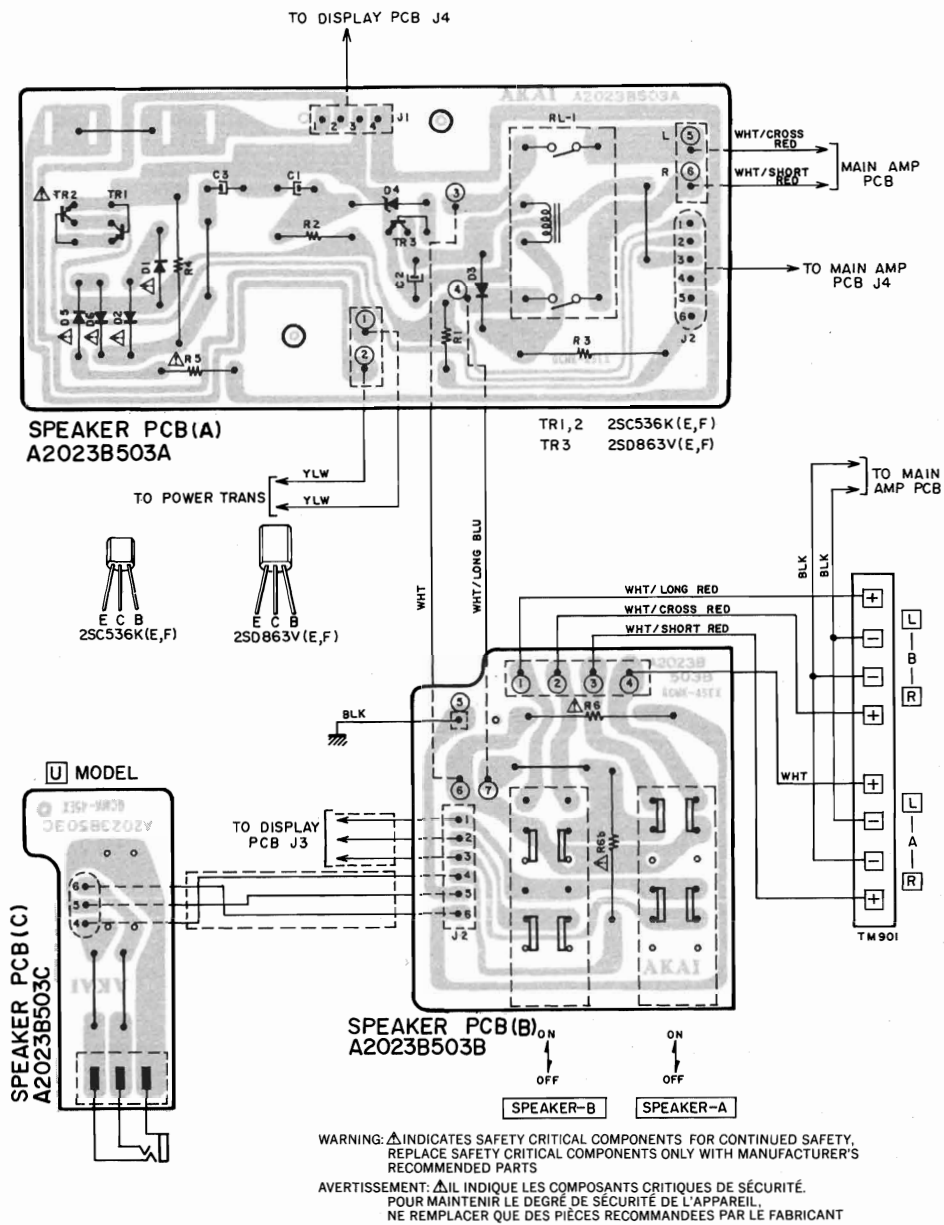

7) MODEL AM-M7 FILTER P.C BOARD A2023C5090

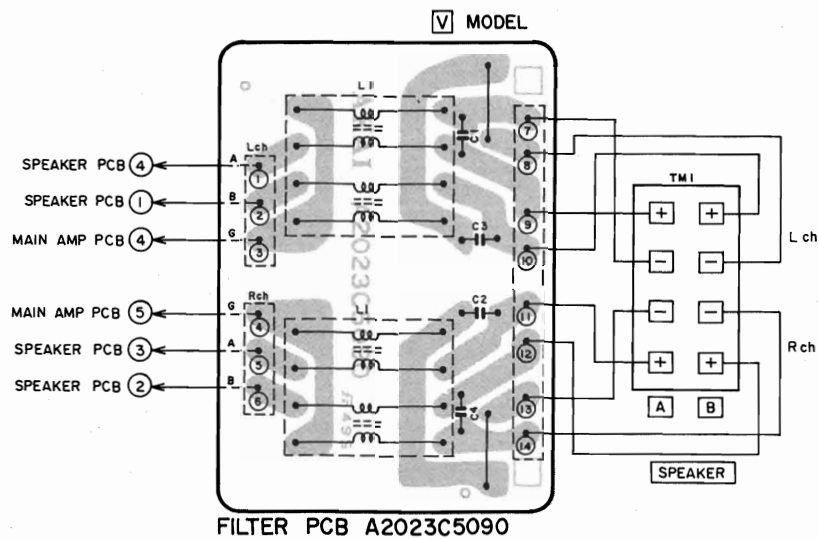

8) MODEL AM-M7 FUSE P.C BOARD A2023D5040

POWER P.C BOARD A2023D5050

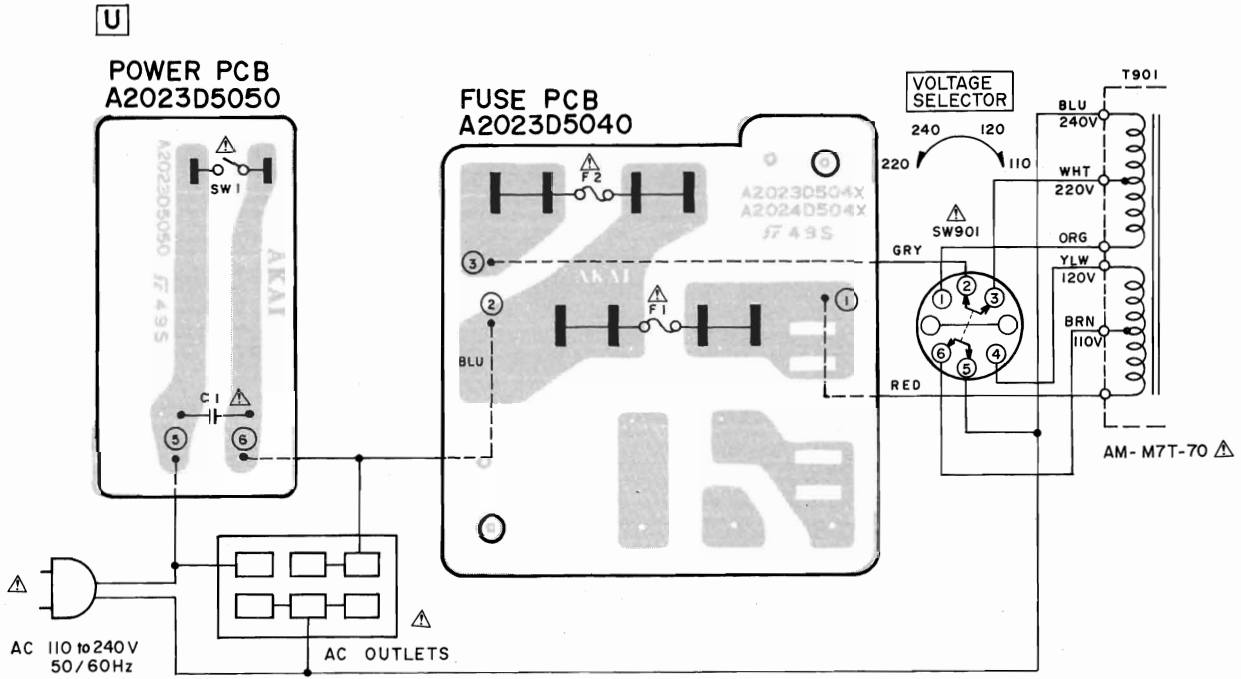

9) MODEL AM-M7 FUSE P.C BOARD A2023D5041, 42

POWER P.C BOARD A2023D5050

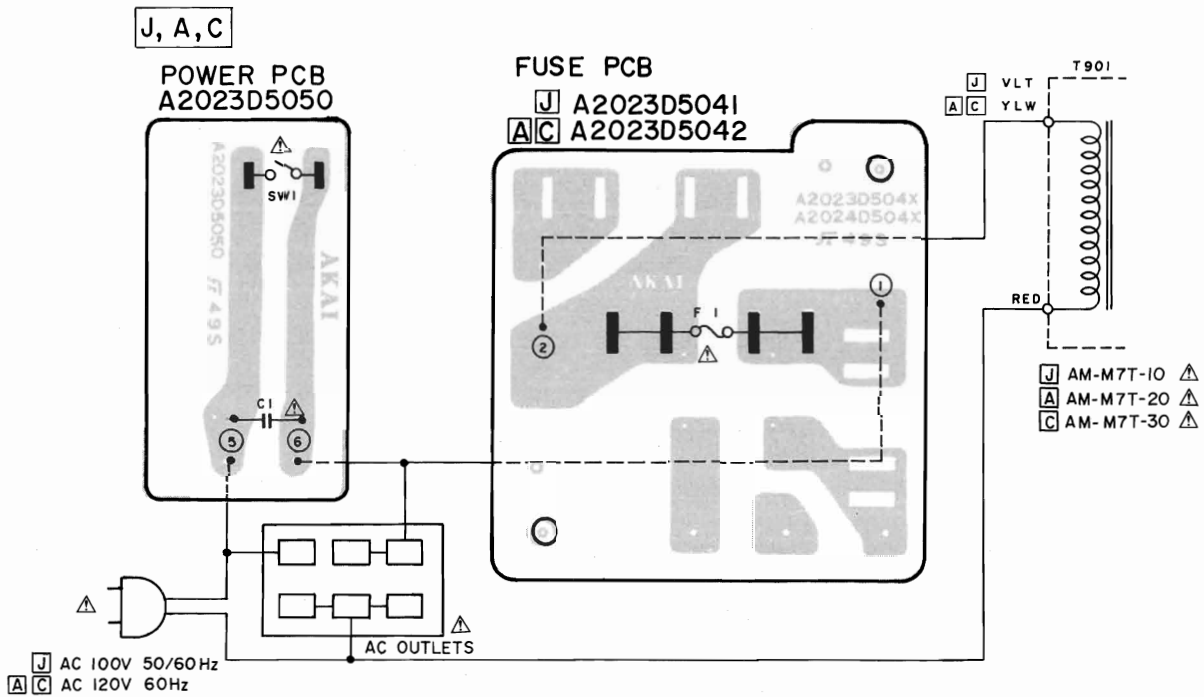

WARNING:  $\Delta$  INDICATES SAFETY CRITICAL COMPONENTS. FOR CONTINUED SAFETY, REPLACE SAFETY CRITICAL COMPONENTS ONLY WITH MANUFACTURER'S RECOMMENDED PARTS

AVERTISSEMENT:  $\Delta$  IL INDIQUE LES COMPOSANTS CRITIQUES DE SÛRETÉ. POUR MAINTENIR LE DEGRÉ DE SÛRETÉ DE L'APPAREIL, NE REMPLACER LES COMPOSANTS DONT LE FONCTIONNEMENT EST CRITIQUE POUR LA SÛRETÉ QUE PAR DES PIÈCES RECOMMANDÉES PAR LE FABRICANT

10) MODEL AM-M7 FUSE P.C BOARD A2023D5043 POWER P.C BOARD A2023D5050

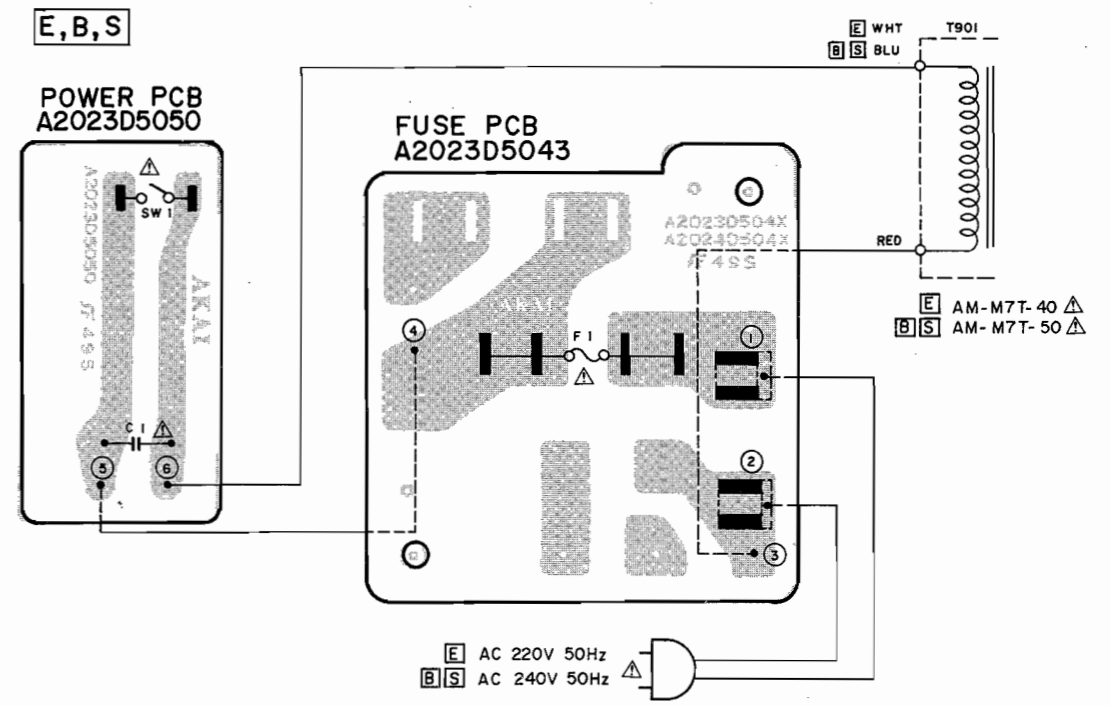

11) MODEL AM-M7 FUSE P.C BOARD A2023D5044 POWER P.C BOARD A2023D5050

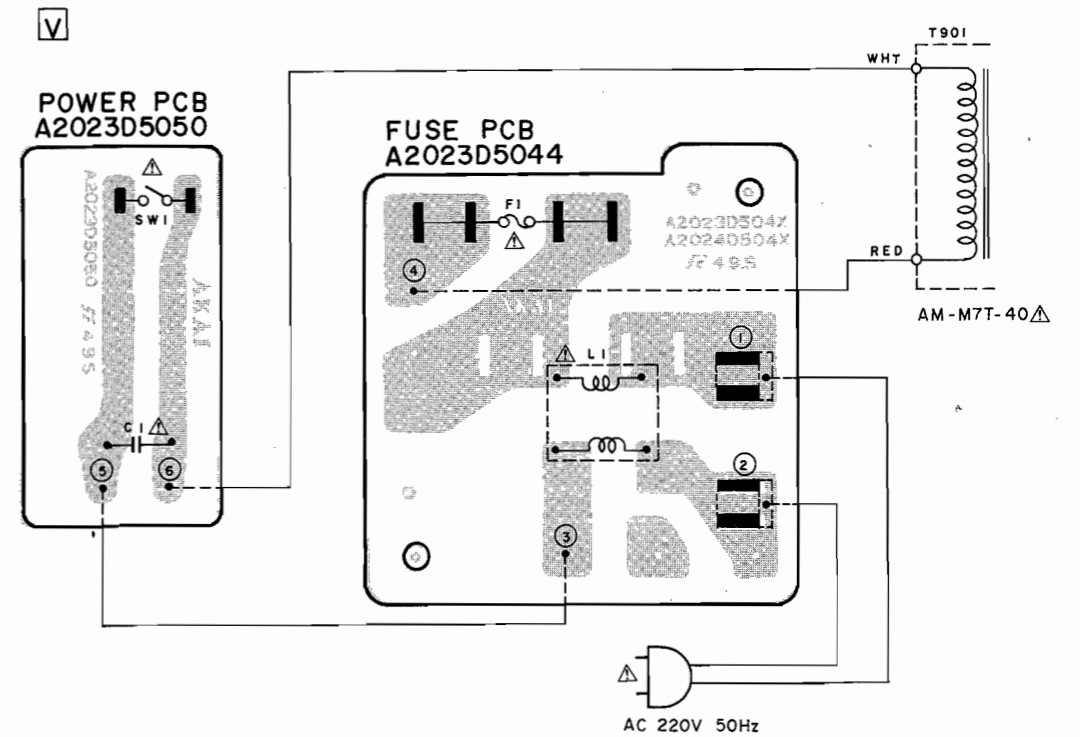

WARNING: Δ INDICATES SAFETY CRITICAL COMPONENTS. FOR CONTINUED SAFETY, REPLACE SAFETY CRITICAL COMPONENTS ONLY WITH MANUFACTURER'S RECOMMENDED PARTS.  
 AVERTISSEMENT: Δ IL INDIQU LES COMPOSANTS CRITIQUES DE SÛRETÉ. POUR MAINTENIR LE DEGRÉ DE SÛRETÉ DE L'APPAREIL NE REMPLACER LES COMPOSANTS DONT LE FONCTIONNEMENT EST CRITIQUE POUR LA SÛRETÉ QUE PAR DES PIÈCES RECOMMANDÉES PAR LE FABRICANT.

---

SECTION 4

**PARTS LIST**

TABLE OF CONTENTS

I. MODEL AT-M5/L .....	63
RECOMMENDED SPARE PARTS .....	63
1. TUNER P.C BOARD BLOCK .....	63
2. ASSEMBLY BLOCK .....	65
3. FINAL ASSEMBLY BLOCK .....	66
II. MODEL AM-M5 .....	67
RECOMMENDED SPARE PARTS .....	67
1. MAIN AMP P.C BOARD BLOCK .....	67
2. EQUALIZER P.C BOARD BLOCK .....	67
3. SPEAKER P.C BOARD BLOCK .....	68
4. TACT P.C BOARD BLOCK .....	68
5. DISPLAY P.C BOARD BLOCK .....	68
6. FILTER P.C BOARD BLOCK .....	68
7. POWER P.C BOARD BLOCK .....	68
8. FUSE P.C BOARD BLOCK .....	68
9. ASSEMBLY BLOCK .....	69
10. FINAL ASSEMBLY BLOCK .....	70
III. MODEL AM-M7 .....	71
RECOMMENDED SPARE PARTS .....	71
1. MAIN AMP P.C BOARD BLOCK .....	71
2. EQUALIZER P.C BOARD BLOCK .....	71
3. SPEAKER P.C BOARD BLOCK .....	72
4. TACT P.C BOARD BLOCK .....	72
5. DISPLAY P.C BOARD BLOCK .....	72
6. FILTER P.C BOARD BLOCK .....	72
7. POWER P.C BOARD BLOCK .....	72
8. FUSE P.C BOARD BLOCK .....	72
9. ASSEMBLY BLOCK .....	73
10. FINAL ASSEMBLY BLOCK .....	74
INDEX .....	75

Resistor and Capacitor which is not listed in this parts list, please refer to  
COMMON LIST FOR SERVICE PARTS.

## ATTENTION

1. When placing an order for parts, be sure to list the parts no., model no., and description. There are instances in which if any of this information is omitted, parts cannot be shipped or the wrong parts will be delivered.
2. Please be careful not to make a mistake in the parts no. If the parts no. is in error, a part different from the one ordered may be delivered.
3. Because parts number and parts unit supply in the Preliminary Parts List may be partially changed, please use this parts list for all future reference.

## HOW TO USE THIS PARTS LIST

1. This Parts List shows the parts that are considered necessary for repairs. Other parts, such as resistors and capacitors, are shown in the "Common List for Service Parts". Select and order such parts from the "Common List for Service Parts".
2. The Recommended Spare Parts shows those parts in the Parts List which are considered particularly important for service.
3. Parts not shown in the Parts List and "Common List for Service Parts" will not be supplied in principle.
4. How to read list

a) Mechanism Block

b) P.C Board Block

### 2. HEAD BASE BLOCK

REF. NO.	PARTS NO.	DESCRIPTION
2-1x	BH-T2023A320A	HEAD BASE BLOCK GX-F66R
2-2	HP-H2206A010A	HEAD R/P PR4-8FU C
2-3	ZS-477876	PAN20x03STL CMT
2-4	ZS-536488	BID20x08STL CMT
2-5	ZG-402895	CS ANGLE ADJUST SPRING

SP (Service Parts) Classification

A small "x" indicates the inability to show that particular part in the Photo or Illustration.

This number corresponds with the individual parts index number in that figure

This number corresponds with the Figure Number

### 6. SYS. CON. P.C BOARD BLOCK

REF. NO.	PARTS NO.	DESCRIPTION
6-1	BA-T2034A070A	PC SYS CON BLK GX-F44R
6-IC1	EI-324536	IC HD14049BP
6-IC2	EI-336801	IC MB8841-564M
6-IC3	EI-331661	IC SN7405N
6-IC4	EI-336725	IC M54527P
6-TR1to4	ET-200985	TR 2SC2603 F,G
6-TR5to28	ET-554657	TR 2SA733A P,Q
6-D1	ED-318292	D SILICON H 1S2473T-77 T26
6-D2to4	ED-308952	D GERMA V 1K34A-LR F07
6-D5to10	ED-318292	D SILICON H 1S2473T-77 T26
6-X1	EI-318384	OSC X'TAL NC-18C 3.579545MHZ

SP (Service Parts) Classification

This reference numbers corresponds with symbol numbers of Schematic Diagrams.

5. Both the kind of part and installation position can be determined by the Parts Number. To determine where a parts number is listed, utilize Parts Index at end of Parts List. It is necessary first of all to find the Parts Number. This can be accomplished by using the Reference Number listed at right of parts number in the Parts Index.

## WARNING

△ INDICATES SAFETY CRITICAL COMPONENTS FOR CONTINUED SAFETY, REPLACE SAFETY CRITICAL COMPONENTS ONLY WITH MANUFACTURE'S RECOMMENDED PARTS

## AVERTISSEMENT

△ IL INDIQUE LES COMPOSANTS CRITIQUES DE SÉCURITÉ. POUR MAINTENIR LE DEGRÉ DE SÉCURITÉ DE L'APPAREIL, NE REMPLACER QUE DES PIÈCES RECOMMANDÉES PAR LE FABRICANT

# I. MODEL AT-M5/L

## RECOMMENDED SPARE PARTS

Because, if the parts listed below are on hand, almost any repair can be accomplished, we suggest that you stock these Recommended Spare Parts Items.

REF. NO.	PARTS NO.	DESCRIPTION
1	BT-344374	△ TRANS POWER AT-M5T-10 (J)
2	BT-344375	△ TRANS POWER AT-M5T-20 (A)
3	BT-344376	△ TRANS POWER AT-M5T-30 (C)
4	BT-344377	△ TRANS POWER AT-M5T-40 (V)
5	BT-347888	△ TRANS POWER AT-M5T-41 (E)
6	BT-344378	△ TRANS POWER AT-M5T-50 (S,B)
7	BT-344379	△ TRANS POWER AT-M5T-70 (U)
8	EC-330692	C S-FIX H TZ03R200E 4.2-20
9	EC-332222	C S-FIX H TZ03R300E 5.2-30
10	EC-337772	C S-FIX H TZ03Z070E 2.0-7
11	ED-336805	△ D SILICON DS135D-KB1 200/1.0A
12	ED-330218	△ D ZENER H HZ15L 2
13	ED-344153	△ D ZENER H 05Z30 Y
14	ED-344444	D LED SLP-436B-01 AMBER
15	ED-301911	D SILICON H DS448
16	ED-200469	D SILICON H DS448 FA5 F10
17	ED-336832	D VARACTOR SVC211SP
18	ED-337605	D VARACTOR SVC333 (A) DOUBLE
19	ED-323057	D VARISTER MV12
20	ED-336944	D ZENER H 05Z16 X,Y
21	ED-338049	D ZENER H 05Z24 Y
22	ED-347701	D ZENER H 05Z6.2 Z
23	EF-300599	△ FUSE FST3100 T 250V 0.40A (E,V,S,E,B)
24	EF-336834	△ FUSE FST3100 TIME 250V 0.16A (E,V,S,E,B)
25	EF-308933	△ FUSE TSC A 250V 0.20A (U)
26	EF-308848	△ FUSE TSC 125V 0.40A (C,A)
27	EI-322248	IC LA1231N
28	EI-202218	IC LA1245
29	EI-343349	IC LA3390
30	EI-337013	IC LB1290
31	EI-330689	IC LC4011B
32	EI-344436	IC TC9147P
33	EI-344438	IC TD6104P
34	EI-344437	IC TD6301AP
35	EI-344422	OSC X'TAL HC-18/U 7.200000MHz
36	EM-344372	IND FL 9-BT-10ZYK CHARACTER
37	ER-344434	FILTER CE BFU450C4N 0.450MHz
38	ER-338338	FILTER CE MS36KY-A 10.7MHz
39	ER-336804	FILTER CE SFE10.7MA8 10.7MHz
40	ER-344435	FILTER CE SFU450B9 0.450MHz
41	ER-336830	FILTER LC LP BL-34HD
42	ER-341654	FILTER LC LP 42W-1001
43	ER-315407	FILTER CE SFE10.7MMKA 10.7MHz
44	ER-315045	R CB H F10 RDS 1/4W 111J
45	ES-337902	△ SW PUSH SDDL1P 01-1
46	ES-344439	SW SLIDE 00420451 2-04-02
47	ES-344445	SW TACT EVQ-QHR12B
48	ES-336780	SW TACT KHH10902
49	ET-322775	△ TR 2SC536K-NP E,F,G
50	ET-452531	△ TR 2SD313HP E,F
51	ET-655356	△ TR 2SD571 L,M
52	ET-330588	TR FET 2SK19 O,Y
53	ET-336937	TR FET 2SK223 E,F
54	ET-337743	TR FET 3SK107 E
55	ET-322778	TR 2SA608K-NP E,F,G
56	ET-200505	TR 2SC2603 E,F
57	ET-338410	TR 2SC2878 A,B
58	ET-336869	TR 2SC2999 C,D
59	ET-336935	TR 2SC3000 E,F
60	ET-322775	TR 2SC536K-NP E,F,G
61	ET-618873	TR 2SC930 E,F
62	ET-328437	TR 2SD1012-V F,G
63	ET-337744	TR FET 2SK212 D,E
64	EV-337995	R S-FIX H RVF8P01 3P 103
65	EV-337993	R S-FIX H RVF8P01 3P 203

## 1. TUNER P.C BOARD BLOCK

REF. NO.	PARTS NO.	DESCRIPTION
1-1	BAA3038A030A	PC TUNER BLK AT-M5 (U)
1-2	BA-A3038A030B	PC TUNER BLK AT-M5 (J)
1-3	BA-A3038A030C	PC TUNER BLK AT-M5 (C)
1-4	BA-A3038A030D	PC TUNER BLK AT-M5 (A)
1-5	BA-A3038A030E	PC TUNER BLK AT-M5 (E)
1-6	BA-A3038A030F	PC TUNER BLK AT-M5 (V)
1-7	BA-A3038A030G	PC TUNER BLK AT-M5 (S)
1-8	BA-A3038A030H	PC TUNER BLK AT-M5L (E)
1-9	BA-A3038A030J	PC TUNER BLK AT-M5L (B)
<b>TUNER P.C BOARD</b>		
1-IC1	EI-322248	IC LA1231N
1-IC2	EI-343349	IC LA3390
1-IC3	EI-202218	IC LA1245
1-IC4	EI-344436	IC TC9147P
1-IC5	EI-344437	IC TD6301AP
1-IC6	EI-344438	IC TD6104P
1-IC7	EI-337013	IC LB1290
1-IC8	EI-330689	IC LC4011B
1-TR1	ET-337743	TR FET 3SK107 E
1-TR2	ET-336869	TR 2SC2999 C,D
1-TR3	ET-337744	TR FET 2SK212 D,E
1-TR4	ET-618873	TR 2SC930 E,F
1-TR5	ET-336935	TR 2SC3000 E,F
1-TR6to8	ET-322775	TR 2SC536K-NP E,F,G
1-TR9	ET-322778	TR 2SA608K-NP E,F,G
1-TR10	ET-322775	TR 2SC536K-NP E,F,G
1-TR11	ET-338410	TR 2SC2878 A,B
1-TR12to15	ET-322778	TR 2SA608K-NP E,F,G
1-TR16	ET-322775	TR 2SC536K-NP E,F,G
1-TR17	ET-330588	TR FET 2SK19 O,Y
1-TR18to20	ET-322775	TR 2SC536K-NP E,F,G
1-TR21	ET-655356	△ TR 2SD571 L,M
1-TR22	ET-452531	△ TR 2SD313HP E,F
1-TR23	ET-322778	TR 2SA608K-NP E,F,G
1-TR24,25	ET-322775	TR 2SC536K-NP E,F,G
1-TR26	ET-322778	TR 2SA608K-NP E,F,G
1-TR27	ET-322775	TR 2SC536K-NP E,F,G
1-TR28	ET-322775	△ TR 2SC536K-NP E,F,G
1-TR29	ET-322775	TR 2SC536K-NP E,F,G
1-TR30	ET-322775	△ TR 2SC536K-NP E,F,G
1-TR31	ET-322778	TR 2SA608K-NP E,F,G
1-TR32,33	ET-328437	TR 2SD1012-V F,G
1-TR35	ET-336937	TR FET 2SK223 E,F
1-TR36	ET-322775	TR 2SC536K-NP E,F,G
1-TR37,38	ET-322778	TR 2SA608K-NP E,F,G
1-TR39to42	ET-322775	TR 2SC536K-NP E,F,G
1-TR44	ET-322775	TR 2SC536K-NP E,F,G
1-TR46,47	ET-322775	TR 2SC536K-NP E,F,G
1-TR48	ET-322778	TR 2SA608K-NP E,F,G
1-TR51	ET-200505	TR 2SC2603 E,F
1-D1toD4	ED-336832	D VARACTOR SVC211SP
1-D5,6	ED-301911	D SILICON H DS448
1-D7,8	ED-337605	D VARACTOR SVC333 (A) DOUBLE
1-D9	ED-301911	D SILICON H DS448
1-D10	ED-323057	D VARISTER MV12
1-D11,12	ED-301911	D SILICON H DS448
1-D13	ED-347701	D ZENER H 05Z6.2 Z
1-D14	ED-330218	△ D ZENER H HZ15L 2
1-D15to18	ED-336805	△ D SILICON DS135D-KB1 200/1.0A
1-D19	ED-336805	D SILICON DS135D-KB1 200/1.0A
1-D20	ED-344153	△ D ZENER H 05Z30 Y
1-D21	ED-338049	D ZENER H 05Z24 Y
1-D23,24	ED-301911	D SILICON H DS448
1-D25	ED-336944	D ZENER H 05Z16 X,Y
1-D26,27	ED-301911	D SILICON H DS448
1-D29to40	ED-301911	D SILICON H DS448
1-D41,42	ED-200469	D SILICON H DS448 FA5 F10
1-D45,46	ED-301911	D SILICON H DS448
1-VC1to4	EC-337772	C S-FIX H TZ03Z070E 2.0-7
1-VC5	EC-330692	C S-FIX H TZ03R200E 4.2-20

REF. NO.	PARTS NO.	DESCRIPTION
1-VC6	EC-332222	C S-FIX H TZ03R300E 5.2-30 M5L (E,B) ONLY
1-L1	EO-336872	COIL VARI 2 TFEI-ANT-U EXCEPT (J)
1-L1	EO-336939	COIL VARI 2 TFEI-ANT-J (J) ONLY
1-L2	EO-336873	COIL VARI 2 TFEI-RF-1
1-L3	EO-336938	COIL VARI 2 TFEI-RF-2
1-L4	EO-336871	COIL VARI 2 TFEI-OSC-U EXCEPT (J)
1-L4	EO-336940	COIL VARI 2 TFEI-OSC-J (J) ONLY
1-L5	EO-332120	COIL FIX 2 103AK-005A 2.20μH
1-L6	EO-338409	COIL LF FKOB 160MH02 250μH
1-T1	EO-337640	COIL IFT 119AC-15533X 10.7MHz
1-T2	EO-344425	COIL DET 2 77-1119-01
1-T3	EO-344433	COIL DET 2 77-1120-01
1-T4	EO-337598	COIL VARI 2 25A-1353-01
1-T5	EO-337599	COIL VARI 2 25A-1354-03 M5L (E,B) ONLY
1-T6	EO-348209	COIL OSC 2 7NR-8646Y 115.0μH
1-T7	EO-307786	COIL OSC 2 7NR-6722Y 580μH M5L (E,B) ONLY
1-T8	EO-343351	COIL IFT PEGK0008B-01 455KHz
1-T9	EO-202216	COIL IFT 7MC-6733C 460KHz
1-FL1	ER-315407	FILTET CE SFE10.7MMKA 10.7MHz
1-FL1E	ER-345729	FILTER CE SFE10.7MZ1KA 10.7MHz M5L (E) ONLY
1-FL2	ER-336804	FILTER CE SFE10.7MA8 10.7MHz EXCEPT (V)
1-FL2	ER-338338	FILTER CE MS3GKY-A 10.7MHz M5 (V), M5L (E)
1-FL3	ER-341654	FILTER LC LP 42W-1001
1-FL4	ER-344434	FILTER CE BFU450C4N 0.450MHz
1-FL5	ER-344435	FILTER CE SFU450B9 0.450MHz
1-FL6	ER-336830	FILTER LC LP BL-34HD (V) ONLY
1-FL7	ER-344435	FILTER CE SFU450B9 0.450MHz M5L (E,B) ONLY
1-VR1	EV-337993	R S-FIX H RVF8P01 3P 203
1-VR2	EV-337995	R S-FIX H RVF8P01 3P 103
1-R21,22	ER-324480	△ R CB H S10 FS RDS 1/4W 470J
1-R32,33	ER-324337	△ R CB H S10 FS RDS 1/4W 560J
1-R46,47	ER-324337	△ R CB H S10 FS RDS 1/4W 560J
1-R60,61	ER-324337	△ R CB H S10 FS RDS 1/4W 560J
1-R100	ER-324185	△ R CB H S10 FS RDS 1/4W 221J
1-R101	ER-324184	△ R CB H S10 FS RDS 1/4W 121J
1-R119	ER-672816	△ R CB H RD 1/2W 225J
1-R120	ER-322787	△ R CB H S10 FS RDS 1/4W 100J
1-R132	ER-324934	△ R CB H S10 FS RDS 1/4W 220J
1-R133	ER-323074	△ R CB H S10 FS RDS 1/4W 102J
1-R136	ER-200944	△ R CB H S10 FS RDS 1/4W 152J
1-R140	ER-328067	△ R CB H S10 FS RDS 1/4W 331J
1-R181	ER-324934	△ R CB H S10 FS RDS 1/4W 220J
1-R251	ER-328067	△ R CB H S10 FS RDS 1/4W 331J
1-C48,49	EC-344155	G PP V F05 PP 181J 50DC (U) ONLY
1-C56	EC-344486	C PP V F05 PP 391J 50DC EXCEPT (C,A)
1-C56	EC-344478	C PP V F05 PP 561J 50DC (C,A) ONLY
1-C57	EC-344486	C PP V F05 PP 391J 50DC EXCEPT (C,A)
1-C57	EC-344478	C PP V F05 PP 561J 50DC (C,A) ONLY
1-C62,63	EC-344484	C PP V F05 PP 392J 50DC
1-C65	EC-344483	C PP V F05 PP 102J 50DC
1-C71	EC-344481	C PP V F05 PP 4700G 50DC
1-C72	EC-344482	C PP V F05 PP 161J 50DC M5L (E,B) ONLY
1-C114	EC-320548	△ C CE V F 103Z 250AC (U,J,C)

REF. NO.	PARTS NO.	DESCRIPTION
1-C114	EC-338411	△ C CE V FZ 103P 400AC (A)
1-C114	EC-338577	△ C CE V F 472M 400AC (E)
1-C114	EC-338496	△ C CE V FZ 472P 400AC (V,S,B)
1-C123	EC-344157	C DOUBLE LAYER 473Z 5.5DC
1-X1	EI-344422	OSC X'TAL HC-18/U 7.200000 MHz
1-SW1	ES-337902	△ SW PUSH SDDL1P 01-1
1-SW2	ES-344445	SW TACT EVQ-QHR12B
1-SW3	ES-344439	SW SLIDE 00420451 2-04-02 (U) ONLY
1-TM1	EJ-344423	TERMINAL SCREW YKD31-0133 P 2P

The AT-M5L AEF Model uses some different parts on TUNER P.C BOARD and OPERATION P.C BOARD. Please refer to the interchangeable parts list shown below when the replacement of these parts is necessary.

AEF PARTS		INTERCHANBEABLE PARTS	
DESCRIPTION	PARTS NO.	DESCRIPTION	PARTS NO.
TR JC501 O. P, Q, R	ET-322775	TR 2SC536K-NP E, F, G	ET-322775
E SILICON H 1N404G	ED-336805	D SILICON DS135D-KB 1 200/1.0A	ED-336805
D ZENER H BZX55-C6V2	ED-347701	D ZENER H 0526.2 Z	ED-347701
D ZENER H BZX55-C30	ED-344153	D ZENER H 05230 Y	ED-344153
D ZENER H BZX55-C24	ED-338049	D ZEENR H 05224 Y	ED-338049
D ZENER H BZX55-C16	ED-336944	D ZENER H 05216 X, Y	ED-336944
D SILICON H 1N4148	ED-301911	D SILICON H DS448	ED-301911

#### OPERATION P.C BOARD

1B-TR1,2	ET-200505	TR 2SC2603 E,F
1B-D1to20	ED-301911	D SILICON H DS448
1B-D21to30	ED-344444	D LED SLP-436B-01 AMBER
1B-SW1to10	ES-336780	SW TACT KHH10902

#### FLD P.C BOARD

1C-SW1to10	ES-336780	SW TACT KHH10902 (SW 10: AT-M5L ONLY)
1C-IND1	EM-344372	IND FL 9-BT-10ZYK CHARACTER



ASSEMBLY BLOCK

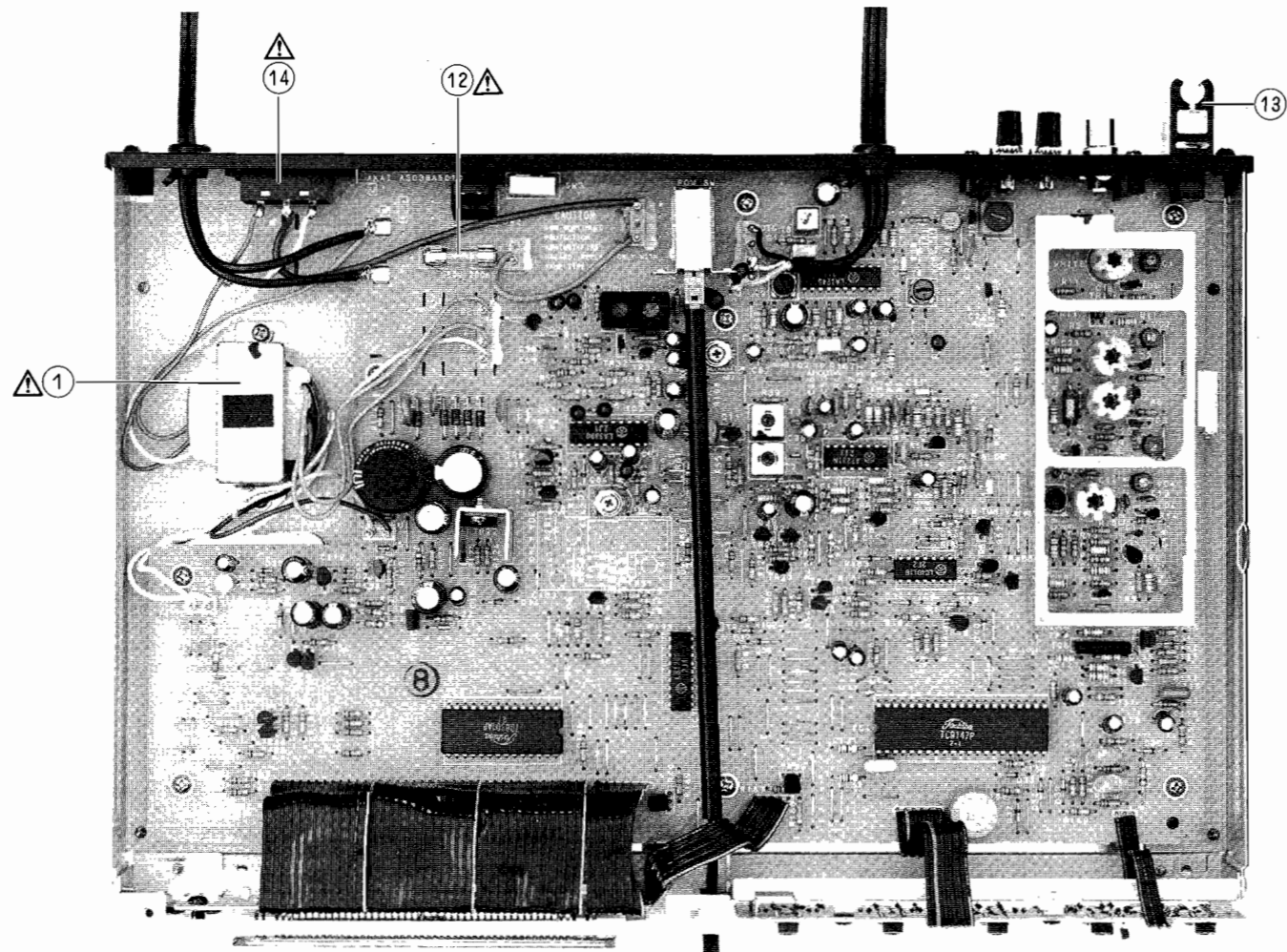

2. ASSEMBLY BLOCK

REF. NO.	PARTS NO.	DESCRIPTION
2-1	BT-344379	△ TRANS POWER AT-M5T-70 (U)
2-2x	BT-344374	△ TRANS POWER AT-M5T-10 (J)
2-3x	BT-344376	△ TRANS POWER AT-M5T-30 (C)
2-4x	BT-344375	△ TRANS POWER AT-M5T-20 (A)
2-5x	BT-347888	△ TRANS POWER AT-M5T-41 (E)
2-6x	BT-344377	△ TRANS POWER AT-M5T-40 (V)
2-7x	BT-344378	△ TRANS POWER AT-M5T-50 (S,B)
2-8x	EF-308848	△ FUSE TSC 125V 0.40A (F1,F2), (C,A)
2-9x	EF-300599	△ FUSE FST3100 T 250V 0.40A (F1,F2) (E,V,S,B)
2-10x	EF-336834	△ FUSE FST3100 TIME 250V 0.16A (F3) (E,V,S,B)
2-11x	EF-336834	△ FUSE FST3100 TIME 250V 0.16A (F4) (B)
2-12	EF-308933	△ FUSE TSC A 250V 0.20A (F4) (U)
2-13	SZ-332739	HOLDER ANTENNA
2-14	ES-348463	△ SW SLIDE X012B11Y 01-2
2-15	SP-344317A	PANEL REAR AT-M5 (U)
2-16x	SP-344317E	PANEL REAR AT-M5 (J)
2-17x	SP-344317B	PANEL REAR AT-M5 (C)
2-18x	SP-344317H	PANEL REAR AT-M5 (A)
2-19x	SP-344317C	PANEL REAR AT-M5 (E,V)
2-20x	SP-344317D	PANEL REAR AT-M5 (S)
2-21x	SP-344317F	PANEL REAR AT-M5L (E)
2-22x	SP-344317G	PANEL REAR AT-M5L (B)
2-23	EW-374894	△ AC CORD 2 CORES VM-0129A J VM-0129A J (U)
2-24x	EW-524845	△ AC CORD 2 CORES VM1165B J (J)
2-25x	EW-305691	△ AC CORD 2 CORES KP-8, SPT-1 UC (C,A)
2-26x	EW-346251	△ AC CORD 2 CORES VM0364, NR N/851 EV (E,V)
2-27x	EW-336924	△ AC CORD 2 CORES KP-560, LTSA-2F S (S)
2-28x	EW-346249	△ AC CORD R-5696 42/0.15x2 EV (B)
2-29	SZ-631945	STRAIN RELIEF SR-4N-4
2-30	EW-344432	CORD SAF-029 3THROW
2-31	SA-305646	RUBBER FOOT (A) (BLACK)
2-32x	ZW-698308	RV NYL30x055 BL
2-33x	ZW-305013	RV POP32 (A)

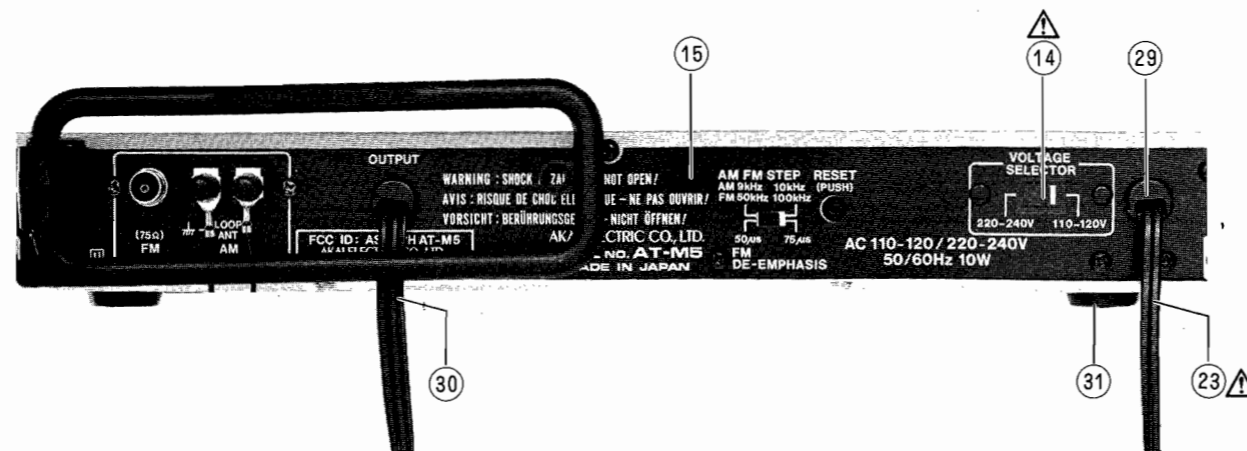

## FINAL ASSEMBLY BLOCK

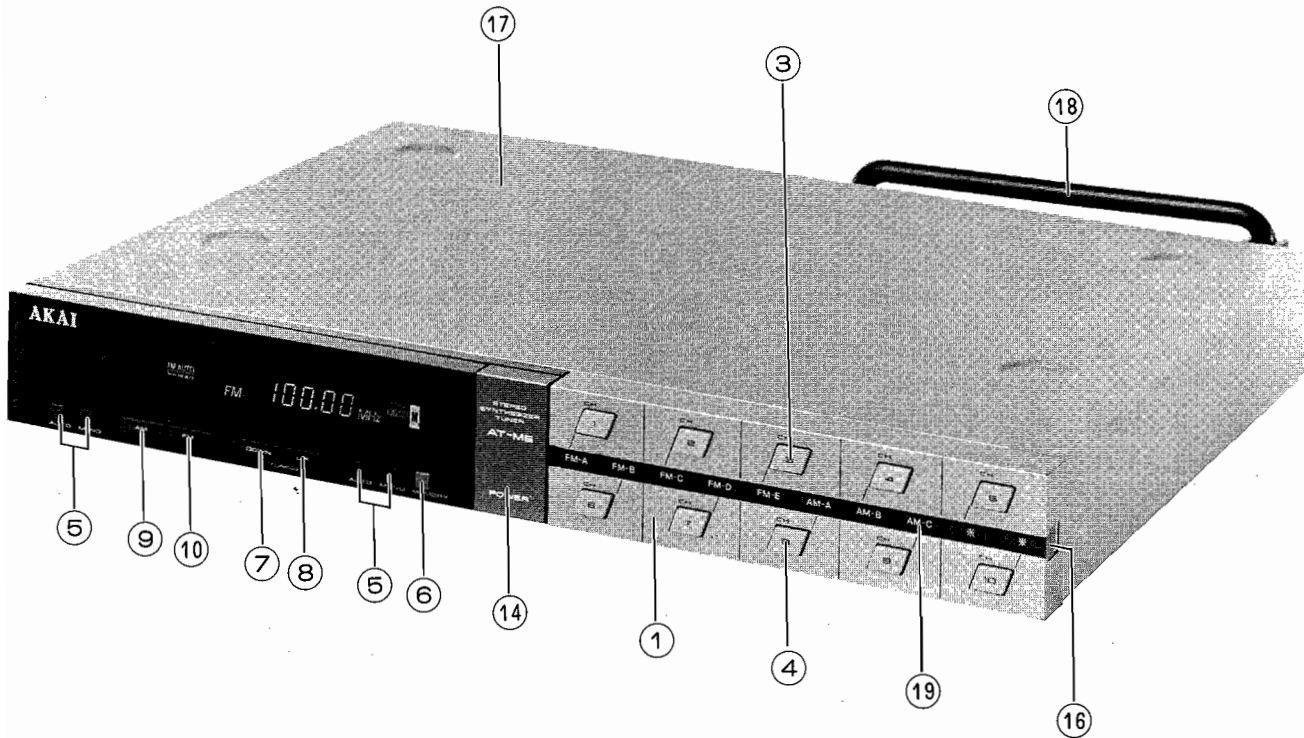

### 3. FINAL ASSEMBLY BLOCK

REF. NO.	PARTS NO.	DESCRIPTION	REF. NO.	PARTS NO.	DESCRIPTION
3-1	BD-A3038A020A	PANEL FRONT BLK AT-M5	3-11x	SK-344308A	KNOB BAND (B-1) (AT-M5L)
3-2	BD-A3038A020B	PANEL FRONT BLK AT-M5L			(LW)
3-3	SK-344314A	RUBBER BUTTON SHEET MEMORY (A)	3-12x	SK-344308B	KNOB BAND (B-2) (AT-M5L)
					(MW)
3-4	SK-344314B	RUBBER BUTTON SHEET MEMORY (B)	3-13x	SK-344308C	KNOB BAND (B-3) (AT-M5L)
					(FM)
3-5	SK-344307A	KNOB (A)	3-14	SK-344321	KNOB POWER AT-M5
3-6	SK-344307B	KNOB (B)			(AT-M5) (POWER)
3-7	SK-344306A	KNOB TUNING (L) (DOWN)	3-15x	SK-344321B	KNOB POWER AT-M5L
3-8	SK-344306B	KNOB TUNING (R) (UP)			(AT-M5L) (POWER)
3-9	SK-344304A	KNOB BAND (A-1) (AT-M5)	3-16	SZ-344313	HOLDER MEMORY
		(AM)	3-17	BC-344323	COVER UPPER
3-10	SK-344304B	KNOB BAND (A-2) (AT-M5)	3-18	EE-337976	ANT LOOP LA-200A
		(FM)	3-19	TA-346165	STATION CARDS

## II. MODEL AM-M5

### RECOMMENDED SPARE PARTS

Because, if the parts listed below are on hand, almost any repair can be accomplished, we suggest that you stock these Recommended Spare Parts Items.

REF. NO.	PARTS NO.	DESCRIPTION
1	BT-344365	△ TRANS POWER AM-M5T-10 (J)
2	BT-344360	△ TRANS POWER AM-M5T-20 (A)
3	BT-344367	△ TRANS POWER AM-M5T-30 (C)
4	BT-344361	△ TRANS POWER AM-M5T-40 (E,V)
5	BT-344363	△ TRANS POWER AM-M5T-50 (B,S)
6	BT-344364	△ TRANS POWER AM-M5T-70 (U)
7	ED-200213	△ D SILICON DBA40C-K15 200/2.6A
8	ED-330218	△ D ZENER H HZ15L 2
9	ED-301911	△ D SILICON H DS448
10	ED-200469	D SILICON H DS448 FA5 F10
11	ED-323057	D VARISTER MV12
12	ED-330218	D ZENER H HZ15L 2
13	ED-307752	D ZENER H HZ6L B2
14	ED-344937	D ZENER H 05Z27 X
15	ED-347623	D ZENER H 05Z6.2 Y,Z
16	EF-602550	△ FUSE SEMKO T 250V 1.25A (F1) (E,V,B,S)
17	EF-601301	△ FUSE SEMKO T 250V 2A (F4,5) (E,V,B,S)
18	EF-249851	△ FUSE SEMKO T 250V 5A (F3) (E,V,B,S)
19	EF-311839	△ FUSE TSC A 250V 1.6A (F1,2) (U)
20	EF-306951	△ FUSE TSC A 250V 2.5A (F4,5) (U)
21	EF-306951	△ FUSE TSC A 250V 2.5A (F4,5) (J)
22	EF-326639	△ FUSE TSC A 250V 3.15A (F1) (J)
23	EF-326613	△ FUSE TSC A 250V 5A (F3) (U)
24	EF-326613	△ FUSE TSC A 250V 5A (F3) (J)
25	EF-306956	△ FUSE TSC 125V 2.5A (F4,5) (C,A)
26	EF-323080	△ FUSE TSC 125V 3.15A (F1) (C,A)
27	EF-346139	△ FUSE TSC 125V 5A (F3) (C,A)
28	EI-346122	△ IC STK-4833
29	EI-343374	IC AA-100
30	EI-337013	IC LB1290
31	EI-338171	IC LC4069UB
32	EI-346071	IC M5218L-21
33	EI-337228	IC M5218L0
34	EI-313797	IC TC4001BP
35	EI-332259	IC TC4052BP
36	EI-343371	IC TC9154P
37	EI-343373	IC TC9156P
38	EM-344388	IND FL BG-137ZK CHARACTER
39	EO-338409	△ COIL LF FK0B160MH02 250μH
40	ES-337902	△ SW PUSH SDDL1P 01-1
41	ES-346123	△ SW SELECTA 0240#13 01-4
42	ES-343377	SW PUSH SUL232A 2 THROW
43	ES-344427	SW REMOTE B SWR1150 L=150
44	ES-344429	SW REMOTE B SWR1168 L=168
45	ES-344426	SW REMOTE O SUFR32 3THROW
46	ES-347694	SW REMOTE S SSR243556 04-3
47	ES-344445	SW TACT EVQ-QHR12B
48	ES-336780	SW TACT KHH10902
49	ET-322598	△ TR 2SB632K E,F
50	ET-310148	△ TR 2SD612K E,F
51	ET-323529	TR 2SA608K-NP E,F
52	ET-316171	TR 2SC536K-NP E,F
53	ET-322775	TR 2SC536K-NP E,F,G

### 1. MAIN AMP P.C BOARD BLOCK

REF. NO.	PARTS NO.	DESCRIPTION
1-1	BA-A2024A060A	PC MAIN AMP BLK AM-M5 (U) (U,J)
1-2	BA-A2024A060B	PC MAIN AMP BLK AM-M5 (C) (C,A)
1-3	BA-A2024A060C	PC MAIN AMP BLK AM-M5 (E) (E,B,S)
1-4	BA-A2024A060D	PC MAIN AMP BLK AM-M5 (V) (V)

#### MAIN AMP P.C BOARD

1-IC1	EI-337228	IC M5218L0
1-IC2	EI-343371	IC TC9154P
1-IC3,4	EI-343373	IC TC9156P
1-IC5	EI-346122	△ IC STK-4833
1-IC6	EI-337228	IC M5218L0
1-TR1	ET-310148	△ TR 2SD612K E,F
1-TR2	ET-322598	△ TR 2SB632K E,F
1-TR3	ET-310148	△ TR 2SD612K E,F
1-TR4	ET-323529	TR 2SA608K-NP E,F
1-TR5,6	ET-316171	TR 2SC536K-NP E,F
1-TR7	ET-323529	TR 2SA608K-NP E,F
1-D1,2	ED-330218	△ D ZENER H HZ15L 2
1-D3,4	ED-307752	D ZENER H HZ6L B2
1-D5	ED-344937	D ZENER H 05Z27 X
1-D6	ED-200213	D SILICON DBA40C-K15 200/2.6A
1-D7	ED-330218	D ZENER H HZ15L 2
1-D8	ED-347623	D ZENER H 05Z6.2 Y,Z
1-D9,10	ED-301911	D SILICON H DS448
1-L1	EO-337880	COIL FIX 2 202AK-018 2.20μH
1-R18	ER-321153	R OMF H S15 FS 1W 102J
1-R24	ER-200940	R CB H S10 FS RDS 1/4W 561J
1-R32	ER-311685	R CB H S15 FS RDS 1/2W 4R7J
1-R38,39	ER-323074	R CB H S10 FS RDS 1/4W 102J
1-R40	ER-322787	R CB H S10 FS RDS 1/4W 100J
1-R43	ER-324480	R CB H S10 FS RDS 1/4W 470J
1-FR1	ER-328520	△ R FUSE ERD2FC S10 1/4W 1000G
1-FR2,3	ER-319455	△ R FUSE ERD2FC S10 1/4W 10R0G
1-C11,12	EC-343382	C EC V CUT SM 682M 45.0DC
1-C31,32	EC-338380	C EC V T05 NP SM 2R2M 50.0DC
1-C33	EC-343976	C EC V T05 NP SM R22M 50.0DC

### 2. EQUALIZER P.C BOARD BLOCK

REF. NO.	PARTS NO.	DESCRIPTION
2-1	BA-A2024A070A	PC EQUALIZER BLK AM-M5 (U) (EXCEPT V)
2-2	BA-A2024A070B	PC EQUALIZER BLK AM-M5 (V) (V)

#### EQUALIZER P.C BOARD

2-IC1	EI-343374	IC AA-100
2-IC2	EI-338171	IC LC4069UB
2-IC3	EI-313797	IC TC4001BP
2-IC4	EI-346071	IC M5218L-21
2-IC5,6	EI-332259	IC TC4052BP
2-TR1	ET-322775	TR 2SC536K-NP E,F,G
2-TR2	ET-316171	TR 2SC536K-NP E,F
2-TR3	ET-322775	TR 2SC536K-NP E,F,G
2-TR4	ET-316171	TR 2SC536K-NP E,F
2-D1to11	ED-301911	D SILICON H DS448
2-SW1	ES-347694	SW REMOTE S SSR243556 04-3
2-SW2	ES-344445	SW TACT EVQ-QHR12B
2-J6	EJ-344370	PIN J YKC21-0081 P 6P
2-J7to9	EJ-344368	PHONE J 3P H5J0847-010 3.5 O
2-T1	EO-336833	COIL IFT 7MC-7736Z 460KHz
2-VL1	EO-337684	COIL FIX 2 FL12R751E 750μH (V)
2-VL2,3	EO-345918	COIL FIX 1 LAL03KH 22.00μH K (V)
2-R34,35	ER-200941	R CB H S10 FS RDS 1/4W 271J
2-R41	ER-325269	R CB H S10 FS RDS 1/4W 222J

#### INPUT P.C BOARD

2-J10,11	EJ-336915	PIN J AJC-054-ABB P 4P
2-VL4to7	EO-345918	COIL FIX 1 LAL03KH 22.00μH K (V)

### 3. SPEAKER P.C BOARD BLOCK

REF. NO.	PARTS NO.	DESCRIPTION
<b>SPEAKER P.C BOARD</b>		
3-SW1	ES-343377	SW PUSH SUL232A 2 THROW
3-R1	ER-308028	R OMF H S15 FS 1W 181J
<b>HEAD PHONE P.C BOARD</b>		
3-VL1	EO-336934	COIL FIX 1 LAL03KH 2.2 $\mu$ H M (V)
3-J2	EJ-344369	PHONE J 3P HSJ0857-110 3.5 O

### 4. TACT P.C BOARD BLOCK

REF. NO.	PARTS NO.	DESCRIPTION
4-SW1to17	ES-336780	SW TACT KHH10902

### 5. DISPLAY P.C BOARD BLOCK

REF. NO.	PARTS NO.	DESCRIPTION
5-1	BA-A2024A100A	PC DISPLAY BLK AM-M5
<b>DISPLAY P.C BOARD</b>		
5-IC1,2	EI-337013	IC LB1290
5-D1to4	ED-200469	D SILICON H DS448 FA5 F10
5-D5	ED-323057	D VARISTER MV12
5-IND1	EM-344388	IND FL BG-137ZK CHARACTER

### 6. FILTER P.C BOARD BLOCK (V Model Only)

REF. NO.	PARTS NO.	DESCRIPTION
6-TM1	EJ-343378	TERMINAL PUSH SQ-2783#90 P 8P (V)
6-L1	EO-342936	COIL BALUN (V)

### 7. POWER P.C BOARD BLOCK

REF. NO.	PARTS NO.	DESCRIPTION
7-SW1	ES-337902	$\Delta$ SW PUSH SDLD1P 01-1
7-C1U	EC-320548	$\Delta$ C CE V F 103Z 250AC (U,J)
7-C1C	EC-314688	$\Delta$ C CE V FZ 103P 125AC (C,A)
7-C1E	EC-338577	$\Delta$ C CE V F 472M 400AC (E,V,B,S)

### 8. FUSE P.C BOARD BLOCK

REF. NO.	PARTS NO.	DESCRIPTION
8-L1	EO-338409	$\Delta$ COIL LF FK0B160MH02 250 $\mu$ H (V)

## ASSEMBLY BLOCK

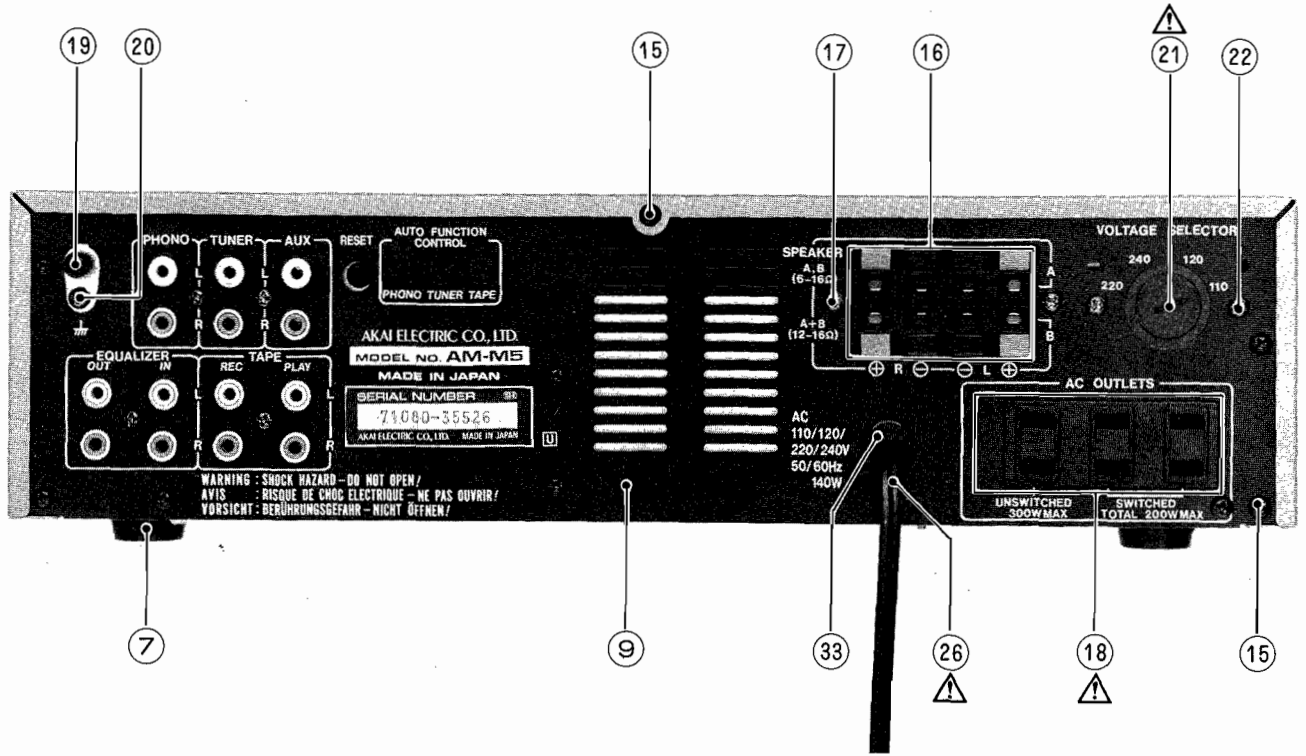

## 9. ASSEMBLY BLOCK

REF. NO.	PARTS NO.	DESCRIPTION	REF. NO.	PARTS NO.	DESCRIPTION
9-1x	BT-344364	△ TRANS POWER AM-M5T-70 (T901) (U)	9-27x	EW-524845	△ AC CORD 2 CORES VM1165B J (J)
9-2x	BT-344365	△ TRANS POWER AM-M5T-10 (T901) (J)	9-28x	EW-343363	△ AC CORD 2 CORES KP-8, SPT-2 UC (C)
9-3x	BT-344367	△ TRANS POWER AM-M5T-30 (T901) (C)	9-29x	EW-305691	△ AC CORD 2 CORES KP-8, SPT-1 UC (A)
9-4x	BT-344360	△ TRANS POWER AM-M5T-20 (T901) (A)	9-30x	EW-346251	△ AC CORD 2 CORES VM0364, NR N/851 EV (E,V)
9-5x	BT-344361	△ TRANS POWER AM-M5T-40 (T901) (E,V)	9-31x	EW-346249	△ AC CORD R-5696 42/0.15x2 EV (B)
9-6x	BT-344363	△ TRANS POWER AM-M5T-50 (T901) (B,S)	9-32x	EW-336924	△ AC CORD 2 CORES KP-560, LTSA-2F S (S)
9-7	SA-202118	FOOT	9-33	SZ-631945	STRAIN RELIEF SR-4N-4
9-8x	ZS-498273	T2BR30X08STL CMT PW080	9-34x	EF-311839	△ FUSE TSC A 250V 1.6A (F1,2) (U)
9-9	SP-344346F	PANEL REAR AM-M5 (U)	9-35x	EF-326613	△ FUSE TSC A 250V 5A (F3) (U)
9-10x	SP-344346K	PANEL REAR AM-M5 (J)	9-36x	EF-306951	△ FUSE TSC A 250V 2.5A (F4,5) (U)
9-11x	SP-344346G	PANEL REAR AM-M5 (C)	9-37x	EF-326639	△ FUSE TSC A 250V 3.15A (F1) (J)
9-12x	SP-344346L	PANEL REAR AM-M5 (A)	9-38x	EF-326613	△ FUSE TSC A 250V 5 A (F3) (J)
9-13x	SP-344346J	PANEL REAR AM-M5 (E,V)	9-39x	EF-306951	△ FUSE TSC A 250V 2.5A (F4,5) (J)
9-14x	SP-344346H	PANEL REAR AM-M5 (B,S)	9-40x	EF-323080	△ FUSE TSC 125V 3.15A (F1) (C,A)
9-15	ZS-319460	T2BR30x06STL BZN PROJECTION	9-41x	EM-306139	△ VU METER D34B80R 0.260MA (F3) (C,A)
9-16	EJ-343389	TERMINAL PUSH SQ-2780#90 S 8P (TM901) (EXCEPT V)	9-42x	EF-306956	△ FUSE TSC 125V 2.5A (F4,5) (C,A)
9-17	ZS-309315	T2BR30X10STL BNI	9-43x	EF-602550	△ FUSE SEMKO T 250V 1.25A (F1) (E,V,B,S)
9-18	EJ-336895	△ SOCKET OUTLET S2T733T174 UJ 3x2P (J901) (U,J,C,A)	9-44x	EF-249851	△ FUSE SEMKO T 250V 5A (F3) (E,V,B,S)
9-19	EJ-329610	TERMINAL W/SCREW UB-0067 L 1P (TM902)	9-45x	EF-601301	△ FUSE SEMKO T 250V 2A (F4,5) (E,V,B,S)
9-20	ZS-447761	T2BR30X06STL BNI	9-46x	ZW-698308	△ RV NYL30x055 BL (A)
9-21	ES-346123	△ SW SELECTA 0240#13 01-4 (SW901) (U)	9-47x	ZW-305013	△ RV POP32 (A)
9-22	ZS-463353	T2BR30X08STL BNI			
9-23x	ES-344426	SW REMOTE O SUFR32 3 THROW			
9-24x	ES-344427	SW REMOTE B SWR1150 L=150			
9-25x	ES-344429	SW REMOTE B SWR1168 L=168			
9-26	EW-374894	△ AC CORD 2 CORES VM-0129A J (U)			

**FINAL ASSEMBLY BLOCK**

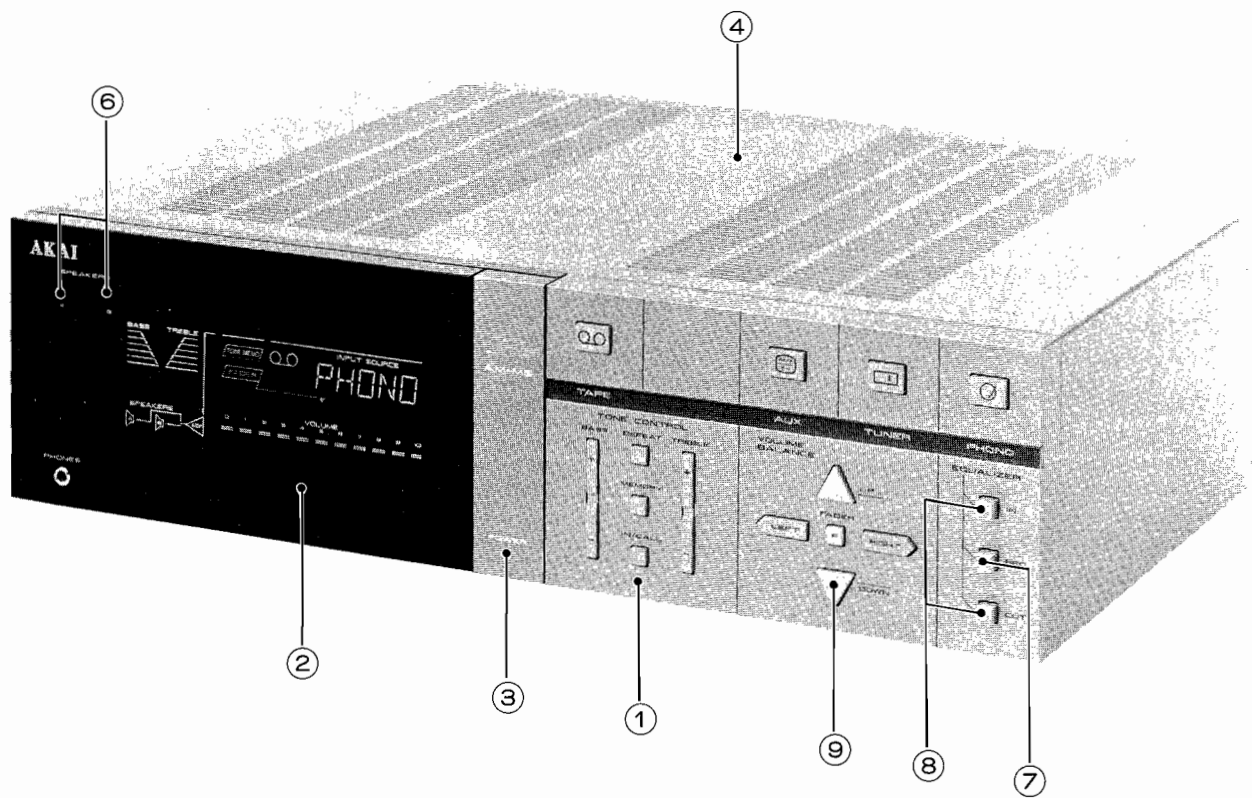

**10. FINAL ASSEMBLY BLOCK**

REF. NO.	PARTS NO.	DESCRIPTION
10-1	BD-A2024A120A	PANEL FRONT BLK AM-M5
10-2	SZ-344341B	WINDOW DISPLAY (2)
10-3	SK-344330B	KNOB POWER AM-M5
10-4	BC-344348A	COVER UPPER (A) (U,J,C,A)
10-5x	BC-344348B	COVER UPPER (B) (E,V,B,S)
10-6	SK-344331A	KNOB PUSH (1)
10-7	SK-344331B	KNOB PUSH (2)
10-8	SK-344331C	KNOB PUSH (3)
10-9	SK-344339B	RUBBER BUTTON SHEET

OPERATION

### III. MODEL AM-M7

#### RECOMMENDED SPARE PARTS

Because, if the parts listed below are on hand, almost any repair can be accomplished, we suggest that you stock these Recommended Spare Parts Items.

REF. NO.	PARTS NO.	DESCRIPTION
1	BT-344382	△ TRANS POWER AM-M7T-10 (J)
2	BT-344385	△ TRANS POWER AM-M7T-20 (A)
3	BT-344383	△ TRANS POWER AM-M7T-30 (C)
4	BT-344386	△ TRANS POWER AM-M7T-40 (E,V)
5	BT-344387	△ TRANS POWER AM-M7T-50 (B,S)
6	BT-344381	△ TRANS POWER AM-M7T-70 (U)
7	ED-200749	△ D SILICON DBA60-K15 400/6.0A
8	ED-344178	△ D ZENER H HZ18L 2
9	ED-337153	D SILICON H DS446FA5 F10
10	ED-301911	D SILICON H DS448
11	ED-200469	D SILICON H DS448 FA5 F10
12	ED-323057	D VARISTER MV12
13	ED-343410	D ZENER H HZ6L A1
14	ED-307752	D ZENER H HZ6L B2
15	ED-327042	D ZENER H WZ-140
16	ED-344937	D ZENER H 05Z27 X
17	ED-347623	D ZENER H 05Z6.2 Y,Z
18	EF-601301	△ FUSE SEMKO T 250V 2A (E,V,B,S)
19	EF-249851	△ FUSE SEMKO T 250V 5A (E,V,B,S)
20	EF-306951	△ FUSE TSC A 250V 2.5A (U)
21	EF-306952	△ FUSE TSC A 250V 4A (J)
22	EF-326613	△ FUSE TSC A 250V 5A (J)
23	EF-306957	△ FUSE TSC 125V 4A (C,A)
24	EF-346139	△ FUSE TSC 125V 5A (C,A)
25	EI-343390	△ IC STK-1050
26	EI-343374	IC AA-100
27	EI-337013	IC LB1290
28	EI-338171	IC LC4069UB
29	EI-337228	IC M5218L0
30	EI-323563	IC STK-3042
31	EI-313797	IC TC4001BP
32	EI-332259	IC TC4052BP
33	EI-343371	IC TC9154P
34	EI-343373	IC TC9156P
35	EM-344388	IND FL BG-137ZK CHARACTER
36	EP-344440	RELAY SIG G2V-282P 2TR 24V
37	EP-337159	RELAY SIG G4Z-2282P 2NO 24V
38	ES-337902	△ SW PUSH SDDL1P 01-1
39	ES-347694	SW REMOTE S SSR243556 04-3
40	ES-344445	SW TACT EVQ-QHR12B
41	ES-336780	SW TACT KHH10902
42	ET-322598	△ TR 2SB632K E,F
43	ET-344176	△ TR 2SD313HP F
44	ET-310148	△ TR 2SD612K E,F
45	ET-337234	TR FET 2SK270 GR,BL
46	ET-305463	TR 2SA970 GR,BL
47	ET-307195	TR 2SC2240 GR,BL
48	ET-316171	TR 2SC536K-NP E,F
49	ET-621235	TR 2SC536NP E,F,G
50	ET-328440	TR 2SD863-V8 E,F

#### 1. MAIN AMP P.C BOARD BLOCK

REF. NO.	PARTS NO.	DESCRIPTION
1-1	BA-A2023A060A	PC MAIN AMP BLK AM-M7 (U) (U)
1-2	BA-A2023A060B	PC MAIN AMP BLK AM-M7 (J) (J)
1-3	BA-A2023A060C	PC MAIN AMP BLK AM-M7 (C) (C,A)
1-4	BA-A2023A060D	PC MAIN AMP BLK AM-M7 (E) (E,V,B,S)

#### MAIN AMP P.C BOARD

1-IC1	EI-337228	IC M5218L0
1-IC2	EI-343371	IC TC9154P
1-IC3,4	EI-343373	IC TC9156P
1-IC5	EI-323563	IC STK-3042
1-IC6	EI-343390	△ IC STK-1050
1-IC7	EI-337228	IC M5218L0
1-TR1	ET-310148	△ TR 2SD612K E,F
1-TR2	ET-322598	△ TR 2SB632K E,F
1-TR3	ET-344176	△ TR 2SD313HP F
1-TR4	ET-305463	TR 2SA970 GR,BL
1-TR5to7	ET-307195	TR 2SC2240 GR,BL
1-D1,2	ED-307752	D ZENER H HZ6L B2
1-D3,4	ED-344178	△ D ZENER H HZ18L 2
1-D5	ED-344937	D ZENER H 05Z27 X
1-D6to9	ED-301911	D SILICON H DS448
1-D10	ED-200749	△ D SILICON DBA60-K15 400/6.0A
1-L1	EO-337880	COIL FIX 2 202AK-018 2.20μH
1-R20,21	ER-328065	R CB H S10 FS RDS 1/4W 182J
1-R26,27	ER-324480	R CB H S10 FS RDS 1/4W 470J
1-R30	ER-324934	R CB H S10 FS RDS 1/4W 220J
1-R40,41	ER-325269	R CB H S10 FS RDS 1/4W 222J
1-R44,46	ER-325269	R CB H S10 FS RDS 1/4W 222J
1-R47,48	ER-308875	R CB H S15 FS RDS 1/2W 100J
1-R58	ER-337773	R OMF H S15 FS 1W 222J
1-FR1,2	ER-344161	△ R FUSE ERD2FC S10 1/4W 82R0G
1-FR3	ER-337756	△ R FUSE ERD2FC S10 1/4W 4700G
1-FR5,6	ER-319455	△ R FUSE ERD2FC S10 1/4W 10R0G
1-C11,12	EC-345776	C EC V CUT SM 103M 50DC
1-C27,28	EC-325320	C EC V F05 NP AWA 2R2M 50DC
1-C29	EC-343855	C EC V F05 NP SM R22M 50.0DC
1-C33	EC-334012	C EC V CUT NP SM 221M 6.3DC

#### 2. EQUALIZER P.C BOARD BLOCK

REF. NO.	PARTS NO.	DESCRIPTION
2-1	BA-A2023A080A	PC EQUALIZER BLK AM-M7 (U) (EXCEPT V)
2-2	BA-A2023A080B	PC EQUALIZER BLK AM-M7 (V) (V)

#### EQUALIZER P.C BOARD

2-IC1	EI-343374	IC AA-100
2-IC2	EI-338171	IC LC4069UB
2-IC3	EI-313797	IC TC4001BP
2-IC4	EI-337228	IC M5218L0
2-IC5to7	EI-332259	IC TC4052BP
2-TR1,2	ET-316171	TR 2SC536K-NP E,F
2-TR3	ET-621235	TR 2SC536NP E,F,G
2-TR4	ET-316171	TR 2SC536K-NP E,F
2-TR5	ET-337234	TR FET 2SK270 GR,BL
2-TR6	ET-316171	TR 2SC536K-NP E,F
2-D1to11	ED-301911	D SILICON H DS448
2-D12	ED-347623	D ZENER H 05Z6.2 Y,Z
2-D13,14	ED-343410	D ZENER H HZ6L A1
2-D15to18	ED-301911	D SILICON H DS448
2-VL1	EO-337684	COIL FIX 2 FL12R751E 750μH (V)
2-VL2,3	EO-345918	COIL FIX 1 LAL03KH 22.00μH K (V)

REF. NO.	PARTS NO.	DESCRIPTION
2-T1	EO-336833	COIL IFT 7MC-7736Z 460KHz
2-J1	EJ-344370	PIN J YKC21-0081 P 6P
2-J2to4	EJ-344368	PHONE J 3P HSJ0847-010 3.5 O
2-SW2	ES-347694	SW REMOTE S SSR243556 04-3
2-SW3	ES-344445	SW TACT EVQ-QHR12B
2-RL1	EP-344440	RELAY SIG G2V-282P 2TR 24V
2-R42,43	ER-200940	△ R CB H S10 FS RDS 1/4W 561J
2-R58,59	ER-325269	R CB H S10 FS RDS 1/4W 222J
2-FR1	ER-328520	R FUSE ERD2FC S10 1/4W 1000G
2-C7	EC-344157	C DOUBLE LAYER 473Z 5.5DC
2-C19	EC-325320	C EC V F05 NP AWA 2R2M 50DC
<b>INPUT P.C BOARD</b>		
2-VL4to9	EO-345918	COIL FIX 1 LAL03KH 22.00μH K
2-J8to10	EJ-336915	PIN J AJC-054-ABB P 4P

#### MM/MC P.C BOARD

2-SW1	ES-344430	SW PUSH JK1044 04-2 S
-------	-----------	-----------------------

### 3. SPEAKER P.C BOARD BLOCK

REF. NO.	PARTS NO.	DESCRIPTION
<b>SPEAKER P.C BOARD (A)</b>		
3-TR1,2	ET-316171	TR 2SC536K-NP E,F
3-TR3	ET-328440	TR 2SD863-V8 E,F
3-D1to3	ED-200469	D SILICON H DS448 FA5 F10
3-D4	ED-327042	D ZENER H WZ-140
3-D5,6	ED-337153	D SILICON H DS446FA5 F10
3-RL1	EP-337159	RELAY SIG G4Z-2282P 2NO 24V
3-R3	ER-333067	R OMF H S20 FS 2W 821J
3-R4	ER-333044	R OMF H S20 FS 2W 152J
3-R5	ER-322787	R CB H S10 FS RDS 1/4W 100J
<b>SPEAKER P.C BOARD (B)</b>		
3-SW1	ES-343377	SW PUSH SUL232A 2 THROW
3-J3	EJ-344369	PHONE J 3P HSJO857-110 3.5 O
3-R6	ER-305722	△ R OMF H S20 FS 2W 221J
<b>SPEAKER P.C BOARD (C)</b>		
3-L1	EO-336934	COIL FIX 1 LAL03KH 2.2μH M (V)

### 4. TACT P.C BOARD BLOCK

REF. NO.	PARTS NO.	DESCRIPTION
4-SW1to17	ES-336780	SW TACT KHH10902

### 5. DISPLAY P.C BOARD BLOCK

REF. NO.	PARTS NO.	DESCRIPTION
5-1	BA-A2023A100A	PC DISPLAY BLK AM-M7

#### DISPLAY P.C BOARD

5-IC1,2	EI-337013	IC LB1290
5-D1to4	ED-200469	D SILICON H DS448 FA5 F10
5-D5	ED-323057	D VARISTER MV12
5-IND1	EM-344388	IND FL BG-137ZK CHARACTER

### 6. FILTER P.C BOARD BLOCK (V Model Only)

REF. NO.	PARTS NO.	DESCRIPTION
6-TM1	EJ-343378	TERMINAL PUSH SQ-2783#90 P 8P (V)
6-L1	EO-342936	COIL BALUN (V)

### 7. POWER P.C BOARD BLOCK

REF. NO.	PARTS NO.	DESCRIPTION
7-SW1	ES-337902	△ SW PUSH SDLD1P 01-1
7-C1U	EC-320548	△ C CE V F 103Z 250AC (U,J)
7-C1C	EC-314688	△ C CE V FZ 103P 125AC (C,A)
7-C1E	EC-338411	△ C CE V FZ 103P 400AC (E,V,B,S)

### 8. FUSE P.C BOARD BLOCK

REF. NO.	PARTS NO.	DESCRIPTION
8-L1	EO-338409	COIL LF FKOB160MH02 250μH (V)



## ASSEMBLY BLOCK

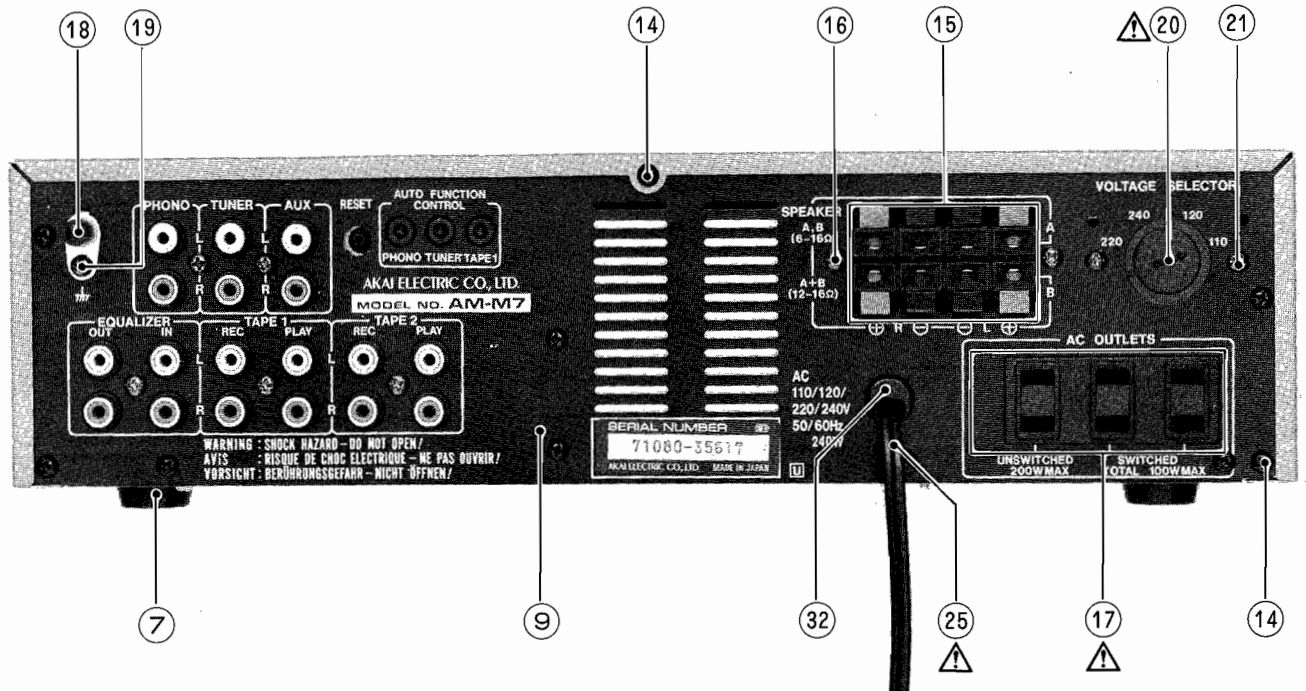

### 9. ASSEMBLY BLOCK

REF. NO.	PARTS NO.	DESCRIPTION	REF. NO.	PARTS NO.	DESCRIPTION
9-1x	BT-344381	⚠ TRANS POWER AM-M7T-70 (T901) (U)	9-22x	ES-344426	SW REMOTE O SUFR32 3THROW
9-2x	BT-344382	⚠ TRANS POWER AM-M7T-10 (T901) (J)	9-23x	ES-344442	SW REMOTE B SWR1192 L=192
9-3x	BT-344383	⚠ TRANS POWER AM-M7T-30 (T901) (C)	9-24x	ES-344443	SW REMOTE B SWR1174 L=174
9-4x	BT-344385	⚠ TRANS POWER AM-M7T-20 (T901) (A)	9-25	EW-374894	⚠ AC CORD 2 CORES VM-0129A J (U)
9-5x	BT-344386	⚠ TRANS POWER AM-M7T-40 (T901) (E,V)	9-26x	EW-524845	⚠ AC CORD 2 CORES VM1165B J (J)
9-6x	BT-344387	⚠ TRANS POWER AM-M7T-50 (T901) (B,S)	9-27x	EW-343363	⚠ AC CORD 2 CORES KP-8, SPT-2 UC (C)
9-7	SA-202118	FOOT	9-28x	EW-305691	⚠ AC CORD 2 CORES KP-8, SPT-1 UC (A)
9-8x	ZS-498273,	T2BR30×08STL CMT PW080	9-29x	EW-346251	⚠ AC CORD 2 CORES VM0364, NR N/851 EV (E,V)
9-9	SP-344346A	PANEL REAR AM-M7 (U)	9-30x	EW-346249	⚠ AC CORD R-5696 42/0.15×2 EV (B)
9-10x	SP-344346B	PANEL REAR AM-M7 (C,A)	9-31x	EW-336924	⚠ AC CORD 2 CORES KP-560, LTSA-2F S (S)
9-11x	SP-344346C	PANEL REAR AM-M7 (E,V)	9-32	SZ-631945	STRAIN RELIEF SR-4N-4
9-12x	SP-344346D	PANEL REAR AM-M7 (B,S)	9-33x	EF-306951	⚠ FUSE TSC A 250V 2.5A (F1,2) (U)
9-13x	SP-344346E	PANEL REAR AM-M7 (J)	9-34x	EF-306952	⚠ FUSE TSC A 250V 4A (F1) (J)
9-14	ZS-319460	T2BR30×06STL BZN PROJECTION	9-35x	EF-326613	⚠ FUSE TSC A 250V 5A (F3,4) (J)
9-15	EJ-343389	TERMINAL PUSH SQ-2780#90 S 8P (TM901) (EXCEPT V)	9-36x	EF-306957	⚠ FUSE TSC 125V 4A (F1) (C,A)
9-16	ZS-309315	T2BR30×10STL BNI	9-37x	EF-346139	⚠ FUSE TSC 125V 5A (F3,4) (C,A)
9-17	EJ-336895	⚠ SOCKET OUTLET S2T733T174 UJ 3×2P (J901) (U,J,C,A)	9-38x	EF-601301	⚠ FUSE SEMKO T 250V 2A (F1) (E,V,B,S)
9-18	EJ-329610	TERMINAL W/SCREW UB-0067 L 1P (TM902)	9-39x	EF-249851	⚠ FUSE SEMKO T 250V 5A (F3,4) (E,V,B,S)
9-19	ZS-447761	T2BR30×06STL BNI	9-40x	ZW-698308	⚠ RV NYL30×055 BL (A)
9-20	ES-346123	⚠ SW SELECTA 0240#13 01-4 (SW901) (U)	9-41x	ZW-305013	⚠ RV POP32 (A)
9-21	ZS-463353	T2BR30×08STL BNI			

## FINAL ASSEMBLY BLOCK

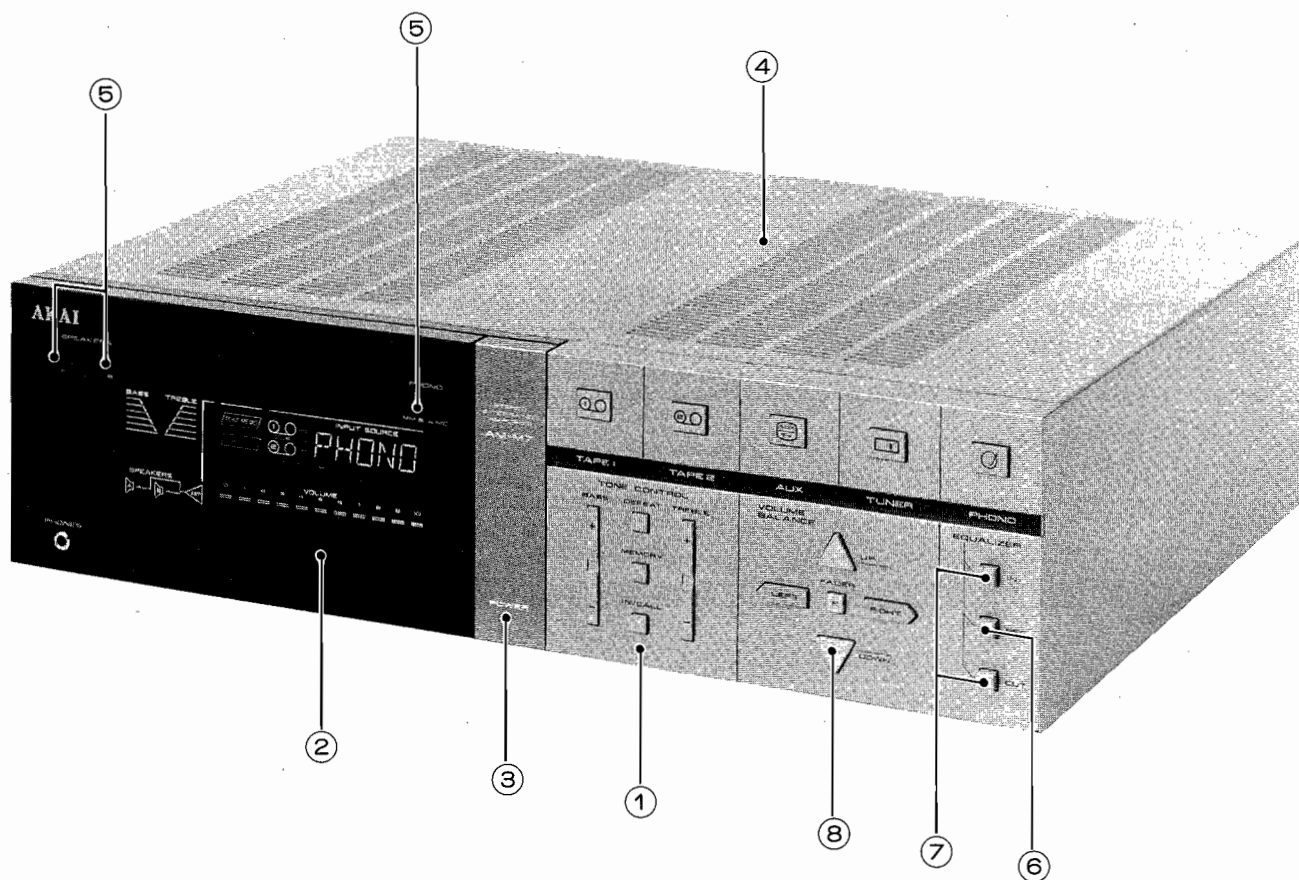

### 10. FINAL ASSEMBLY BLOCK

REF. NO.	PARTS NO.	DESCRIPTION
10-1	BD-A2023A120A	PANEL FRONT BLK AM-M7
10-2	SZ-344341A	WINDOW DISPLAY (1)
10-3	SK-344330	KNOB POWER AM-M7
10-4	BC-344348C	COVER UPPER (C)
10-5	SK-344331A	KNOB PUSH (1)
10-6	SK-344331B	KNOB PUSH (2)
10-7	SK-344331C	KNOB PUSH (3)
10-8	SK-344339A	RUBBER BUTTON SHEET OPERATION (1)

# INDEX

## 1. MODEL AT-M5/L

PARTS NO.	REF. NO.	PARTS NO.	REF. NO.	PARTS NO.	REF. NO.	PARTS NO.	REF. NO.	PARTS NO.	REF. NO.
BA-A3038A030A	1-1	ED-301911	1-D5,6	EO-336939	1-L1	ET-200505	1-TR51	EW-524845	2-24x
BA-A3038A030B	1-2	ED-301911	1-D26,27	EO-336940	1-L4	ET-322775	1-TR28	SA-305646	2-31
BA-A3038A030C	1-3	ED-301911	1-D45,46	EO-337598	1-T4	ET-322775	1-TR27	SK-344304A	3-9
BA-A3038A030D	1-4	ED-301911	1-D23,24	EO-337599	1-T5	ET-322775	1-TR6to8	SK-344304B	3-10
BA-A3038A030E	1-5	ED-301911	1-D11,12	EO-337640	1-T1	ET-322775	1-TR24,25	SK-344306A	3-7
BA-A3038A030F	1-6	ED-323057	1-D10	EO-338409	1-L6	ET-322775	1-TR29	SK-344306B	3-8
BA-A3038A030G	1-7	ED-330218	1-D14	EO-343351	1-T8	ET-322775	1-TR46,47	SK-344307A	3-5
BA-A3038A030H	1-8	ED-336805	1-D15to18	EO-344425	1-T2	ET-322775	1-TR10	SK-344307B	3-6
BA-A3038A030J	1-9	ED-336805	1-D19	EO-344433	1-T3	ET-322775	1-TR18to20	SK-344308A	3-11x
BC-344323	3-17	ED-336832	1-D1toD4	EO-348209	1-T6	ET-322775	1-TR36	SK-344308B	3-12x
BD-A3038A020A	3-1	ED-336944	1-D25	ER-200944	1-R136	ET-322775	1-TR44	SK-344308C	3-13x
BD-A3038A020B	3-2	ED-337605	1-D7,8	ER-315407	1-FL1	ET-322775	1-TR16	SK-344314A	3-3
BT-344374	2-2x	ED-338049	1-D21	ER-322787	1-R120	ET-322775	1-TR30	SK-344314B	3-4
BT-344375	2-4x	ED-344153	1-D20	ER-323074	1-R133	ET-322775	1-TR39to42	SK-344321	3-14
BT-344376	2-3x	ED-344444	1BD21to30	ER-324184	1-R101	ET-322778	1-TR9	SK-344321B	3-15x
BT-344377	2-6x	ED-347701	1-D13	ER-324185	1-R100	ET-322778	1-TR37,38	SP-344317A	2-15
BT-344378	2-7x	EE-337976	3-18	ER-324337	1-R46,47	ET-322778	1-TR12to15	SP-344317B	2-17x
BT-344379	2-1	EF-300599	1-9x	ER-324337	1-R60,61	ET-322778	1-TR23	SP-344317C	2-19x
BT-347888	2-5x	EF-308848	2-8x	ER-324337	1-R32,33	ET-322778	1-TR31	SP-344317D	2-20x
EC-320548	1-C114	EF-308933	2-12	ER-324480	1-R21,22	ET-322778	1-TR48	SP-344317E	2-16x
EC-330692	1-VC5	EF-336834	2-11x	ER-324934	1-R132	ET-322778	1-TR26	SP-344317F	2-21x
EC-332222	1-VC6	EF-336834	2-10x	ER-324934	1-R181	ET-328437	1-TR32,33	SP-344317G	2-22x
EC-337772	1-VC1to4	EI-202218	1-IC3	ER-328067	1-R140	ET-330588	1-TR17	SP-344317H	2-18x
EC-338411	1-C114	EI-322248	1-IC1	ER-328067	1-R251	ET-336869	1-TR2	SZ-332739	2-13
EC-338496	1-C114	EI-330689	1-IC8	ER-336804	1-FL2	ET-336935	1-TR5	SZ-344313	3-16
EC-338577	1-C114	EI-337013	1-IC7	ER-336830	1-FL6	ET-336937	1-TR35	SZ-631945	2-29
EC-344155	1-C48,49	EI-343349	1-IC2	ER-338338	1-FL2	ET-337743	1-TR1	TA-346165	3-19
EC-344157	1-C123	EI-344422	1-X1	ER-341654	1-FL3	ET-337744	1-TR3	ZW-305013	2-33x
EC-344478	1-C57	EI-344436	1-IC4	ER-344434	1-FL4	ET-338410	1-TR11	ZW-698308	2-32x
EC-344478	1-C56	EI-344437	1-IC5	ER-344435	1-FL7	ET-452531	1-TR22		
EC-344481	1-C71	EI-344438	1-IC6	ER-344435	1-FL5	ET-618873	1-TR4		
EC-344482	1-C72	EJ-344423	1-TM1	ER-345729	1-FL1E	ET-655356	1-TR21		
EC-344483	1-C65	EM-344372	1C-IND1	ER-672816	1-R119	EV-337993	1-VR1		
EC-344484	1-C62,63	EO-202216	1-T9	ES-336780	1CSW1to10	RV-337995	1-VR2		
EC-344486	1-C57	EO-307786	1-T7	ES-336780	1BSW1to10	EW-305691	2-25x		
EC-344486	1-C56	EO-332120	1-L5	ES-337902	1-SW1	EW-336924	2-27x		
ED-200469	1D41,42	EO-336871	1-L4	ES-344439	1-SW3	EW-344432	2-30		
ED-301911	1-D9	EO-336872	1-L1	ES-344445	1-SW2	EW-346249	2-28x		
ED-301911	1D29to40	EO-336873	1-L2	ES-348463	2-14	EW-346251	2-26x		
ED-301911	1BD1to20	EO-336938	1-L3	ET-200505	1B-TR1,2	EW-374894	2-23		

## 2. MODEL AM-M5

PARTS NO.	REF. NO.	PARTS NO.	REF. NO.	PARTS NO.	REF. NO.	PARTS NO.	REF. NO.	PARTS NO.	REF. NO.
BA-A2024A060A	1-1	ED-344937	1-D5	EJ-344369	3-J2	ES-346123	9-21	SP-344346L	9-12x
BA-A2024A060B	1-2	ED-347623	1-D8	EJ-344370	2-J6	ES-347694	2-SW1	SZ-344341B	10-2
BA-A2024A060C	1-3	EF-249851	9-44x	EM-306139	9-41x	ET-310148	1-TR1	SZ-631945	9-33
BA-A2024A060D	1-4	EF-306951	9-36x	EM-344388	5-IND1	ET-310148	1-TR3	ZS-309315	9-17
BA-A2024A070A	2-1	EF-306951	9-39x	EO-336833	2-T1	ET-316171	1-TR5,6	ZS-319460	9-15
BA-A2024A070B	2-2	EF-306956	9-42x	EO-336934	3-VL1	ET-316171	2-TR2	ZS-447761	9-20
BA-A2024A100A	5-1	EF-311839	9-34x	EO-337684	2-VL1	ET-316171	2-TR4	ZS-463353	9-22
BC-344348A	10-4	EF-323080	9-40x	EO-337880	1-L1	ET-322598	1-TR2	ZS-498273	9-8x
BC-344348B	10-5x	EF-326613	9-35x	EO-338409	8-L1	ET-322775	2-TR1	ZW-305013	9-47x
BD-A2024A120A	10-1	EF-326613	9-38x	EO-342936	6-L1	ET-322775	2-TR3	ZW-698308	9-46x
BT-344360	9-4x	EF-326639	9-37x	EO-345918	2-VL2,3	ET-323529	1-TR4		
BT-344361	9-5x	EF-601301	9-45x	EO-345918	2-VL4to7	ET-323529	1-TR7		
BT-344363	9-6x	EF-602550	9-43x	ER-200940	1-R24	EW-305691	9-29x		
BT-344364	9-1x	EI-313797	2-IC3	ER-200941	2-R34,35	EW-336924	9-32x		
BT-344365	9-2x	EI-332259	2-IC5,6	ER-308028	3-R1	EW-343363	9-28x		
BT-344367	9-3x	EI-337013	5-IC1,2	ER-311685	1-R32	EW-346249	9-31x		
EC-314688	7-C1C	EI-337228	1-IC6	ER-319455	1-FR2,3	EW-346251	9-30x		
EC-320548	7-C1U	EI-337228	1-IC1	ER-321153	1-R18	EW-374894	9-26		
EC-338380	1C31,32	EI-338171	2-IC2	ER-322787	1-R40	EW-524845	9-27x		
EC-338577	7-C1E	EI-343371	1-IC2	ER-323074	1-R38,39	SA-202118	9-7		
EC-343382	1C11,12	EI-343373	1-IC3,4	ER-324480	1-R43	SK-344330B	10-3		
EC-343976	1-C33	EI-343374	2-IC1	ER-325269	2-R41	SK-344331A	10-6		
ED-200213	1-D6	EI-346071	2-IC4	ER-328520	1-FR1	SK-344331B	10-7		
ED-200469	5-D1to4	EI-346122	1-IC5	ES-336780	4-SW1to17	SK-344331C	10-8		
ED-301911	1D 9,10	EJ-329610	9-19	ES-337902	7-SW1	SK-344339B	10-9		
ED-301911	2D1to11	EJ-336895	9-18	ES-343377	3-SW1	SP-344346F	9-9		
ED-307752	1-D3,4	EJ-336915	2-J10,11	ES-344426	9-23x	SP-344346G	9-11x		
ED-323057	5-D5	EJ-343378	6-TM1	ES-344427	9-24x	SP-344346H	9-14x		
ED-330218	1-D1,2	EJ-343389	9-16	ES-344429	9-25x	SP-344346J	9-13x		
ED-330218	1-D7	EJ-344368	2-J7to9	ES-344445	2-SW2	SP-344346K	9-10x		

# INDEX

## 3. MODEL AM-M7

PARTS NO.	REF. NO.	PARTS NO.	REF. NO.	PARTS NO.	REF. NO.	PARTS NO.	REF. NO.	PARTS NO.	REF. NO.
BA-A2023A060A	1-1	ER-322787	3-R5						
BA-A2923A060B	1-2	ER-324480	1-R26,27						
BA-A2023A060C	1-3	ER-324934	1-R30						
BA-A2023A060D	1-4	ER-325269	1-R40,41						
BA-A2023A080A	2-1	ER-325269	1-R44,46						
BA-A2023A080B	2-2	ER-325269	2-R58,59						
BA-A2023A100A	5-1	ER-328065	1-R20,21						
BC-344348C	10-4	ER-328520	2-FR1						
BD-A2023A120A	10-1	ER-333044	3-R4						
BT-344381	9-1x	ER-333067	3-R3						
BT-344382	9-2x	ER-337756	1-FR3						
BT-344383	9-3x	ER-337773	1-R58						
BT-344385	9-4x	ER-344161	1-FR1,2						
BT-344386	9-5x	ES-336780	4-SW1to17						
BT-344387	9-6x	ES-337902	7-SW1						
EC-314688	7-C1C	ES-343377	3-SW1						
EC-320548	7-C1U	ES-344426	9-22x						
EC-325320	1-C27,28	ES-344430	2-SW1						
EC-325320	2-C19	ES-344442	9-23x						
EC-334012	1-C33	ES-344443	9-24x						
EC-338411	7-C1E	ES-344445	2-SW3						
EC-343855	1-C29	ES-346123	9-20						
EC-344157	2-C7	ES-347694	2-SW2						
EC-345776	1-C11,12	ET-305463	1-TR4						
ED-200469	3-D1to3	ET-307195	1-TR5to7						
ED-200469	5-D1to4	ET-310148	1-TR1						
ED-200749	1-D10	ET-316171	2-TR1,2						
ED-301911	1-D6to9	ET-316171	2-TR4						
ED-301911	2-D1to11	ET-316171	2-TR6						
ED-301911	2-D15to18	ET-316171	3-TR1,2						
ED-307752	1-D1,2	ET-322598	1-TR2						
ED-323057	5-D5	ET-328440	3-TR3						
ED-327042	3-D4	ET-337234	2-TR5						
ED-337153	3-D5,6	ET-344176	1-TR3						
ED-343410	2-D13,14	ET-621235	2-TR3						
ED-344178	1-D3,4	EW-305691	9-28x						
ED-344937	1-D5	EW-336924	9-31x						
ED-347623	2-D12	EW-343363	9-27x						
EF-249851	9-39x	EW-346249	9-30x						
EF-306951	9-33x	EW-346251	9-29x						
EF-306952	9-34x	EW-374894	9-25						
EF-306957	9-36x	EW-524845	9-26x						
EF-326613	9-35x	SA-202118	9-7						
EF-346139	9-37x	SK-344330	10-3						
EF-601301	9-38x	SK-344331A	10-5						
EI-313797	2-IC3	SK-344331B	10-6						
EI-323563	1-IC5	SK-344331C	10-7						
EI-332259	2-IC5to7	SK-344339A	10-8						
EI-337013	5-IC1,2	SP-344346A	9-9						
EI-337228	1-IC1	SP-344346B	9-10x						
EI-337228	1-IC7	SP-344346C	9-11x						
EI-337228	2-IC4	SP-344346D	9-12x						
EI-338171	2-IC2	SP-344346E	9-13x						
EI-343371	1-IC2	SZ-344341A	10-2						
EI-343373	1-IC3,4	SZ-631945	9-32						
EI-343374	2-IC1	ZS-309315	9-16						
EI-343390	1-IC6	ZS-319460	9-14						
EJ-329610	9-18	ZS-447761	9-19						
EJ-336895	9-17	ZS-463353	9-21						
EJ-336915	2-J8to10	ZS-498273	9-8x						
EJ-343378	6-TM1	ZW-305013	9-41x						
EJ-343389	9-15	ZW-698308	9-40x						
EJ-344368	2-J2to4								
EJ-344369	3-J3								
EJ-344370	2-J1								
EM-344388	5-IND1								
EO-336833	2-T1								
EO-336934	3-L1								
EO-337684	2-VL1								
EO-337880	1-L1								
EO-338409	8-L1								
EO-342936	6-L1								
EO-345918	2-VL2,3								
EO-345918	2-VL4to9								
EP-337159	3-RL1								
EP-344440	2-RL1								
ER-200940	2-R42,43								
ER-305722	3-R6								
ER-308875	1-R47,48								
ER-319455	1-FR5,6								

SECTION 5

# SCHEMATIC DIAGRAM

1. SCHEMATIC DIAGRAM OF ICs .....	77
2. AT-M5 NO. 830212A SCHEMATIC DIAGRAM.....	85
3. AT-M5/L NO. 830213A SCHEMATIC DIAGRAM.....	86
4. AM-M5 NO. 830210A SCHEMATIC DIAGRAM .....	87
5. AM-M7 NO. 830211A SCHEMATIC DIAGRAM .....	88

SCHEMATIC DIAGRAM OF ICs

LA1231N

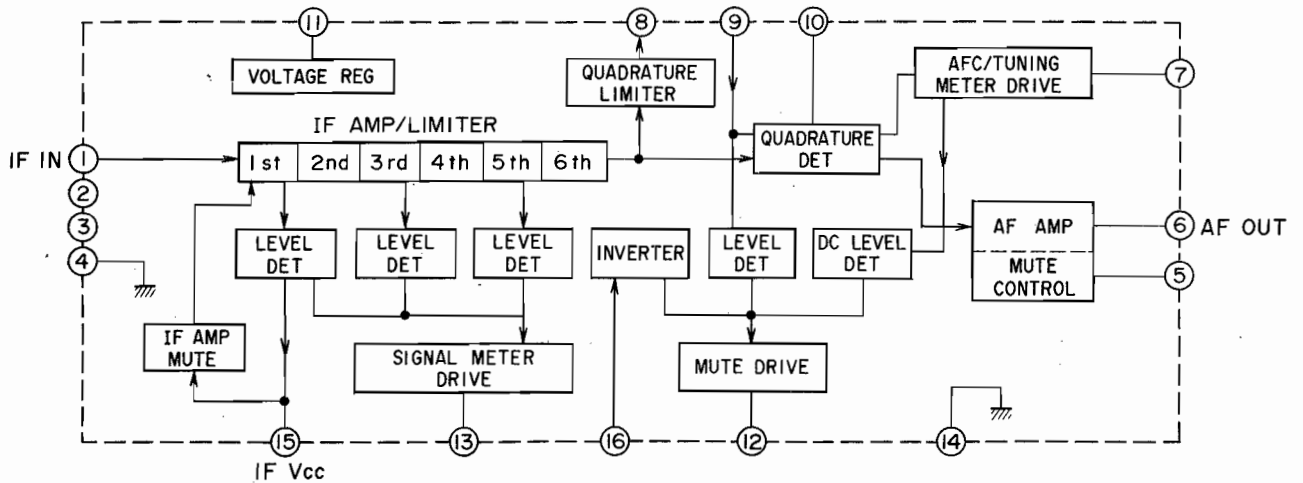

LA1245

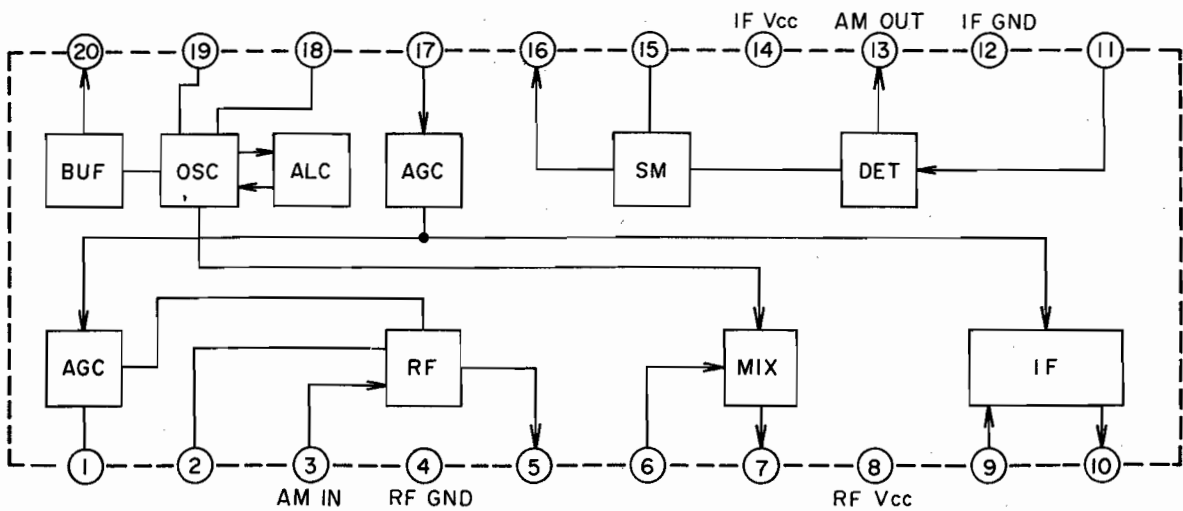

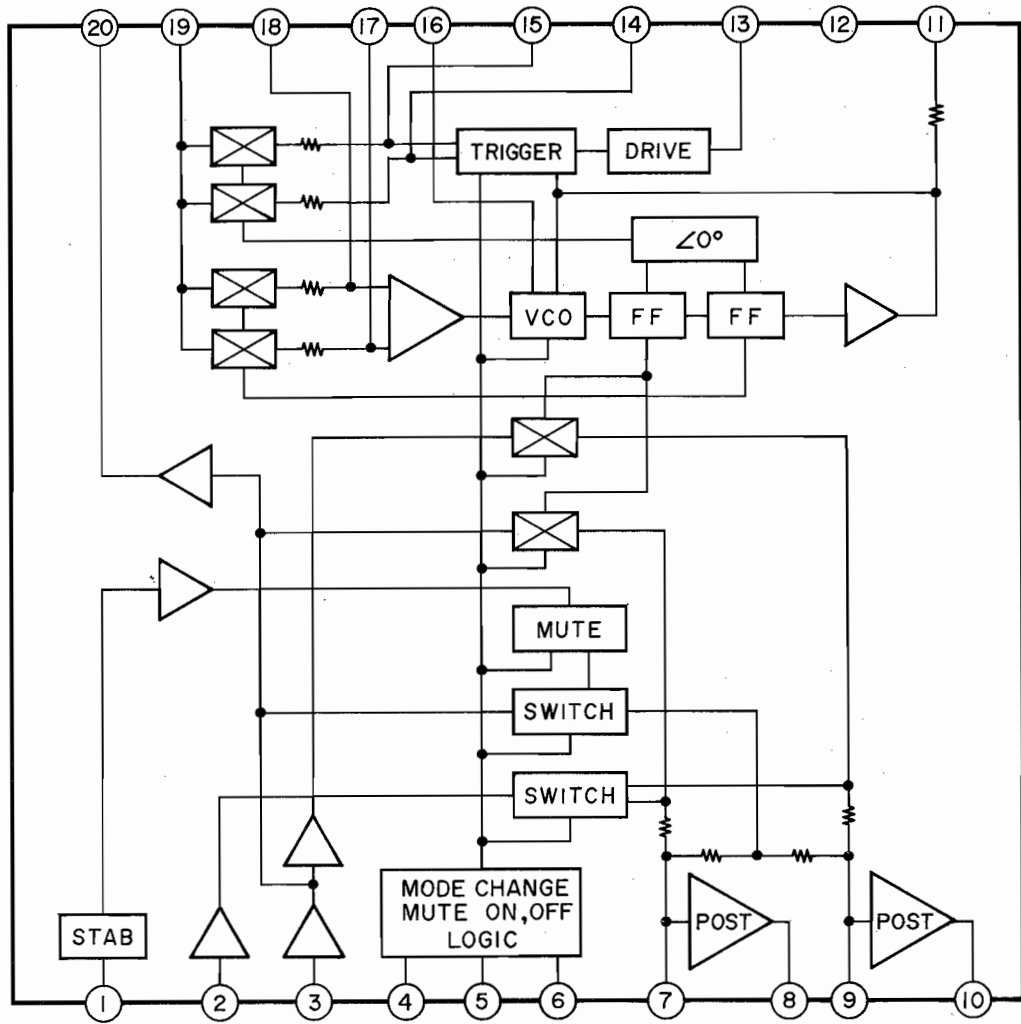

Pin No.	Description	Pin No.	Description
1	VCC	11	Compulsory Mono, VCO Stop, 19kHz Check
2	AM Input	12	GND
3	FM Input	13	Stereo Indicator
4	FM/AM SW Mute Time Constant	14	Pilot Sync Detect Filter
5	Mute Control (ON/OFF)	15	
6	FM/AM SW	16	VCO Time Constant
7	Post Amp (Negative in)	17	PLL Loop Filter
8	Post Amp (LCH out)	18	
9	Post Amp (Negative in)	19	Phase Comparator Input
10	Post Amp (Rch out)	20	Composite Amp Output

**LB1290**

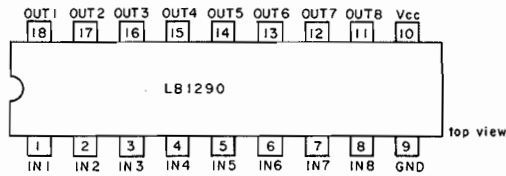
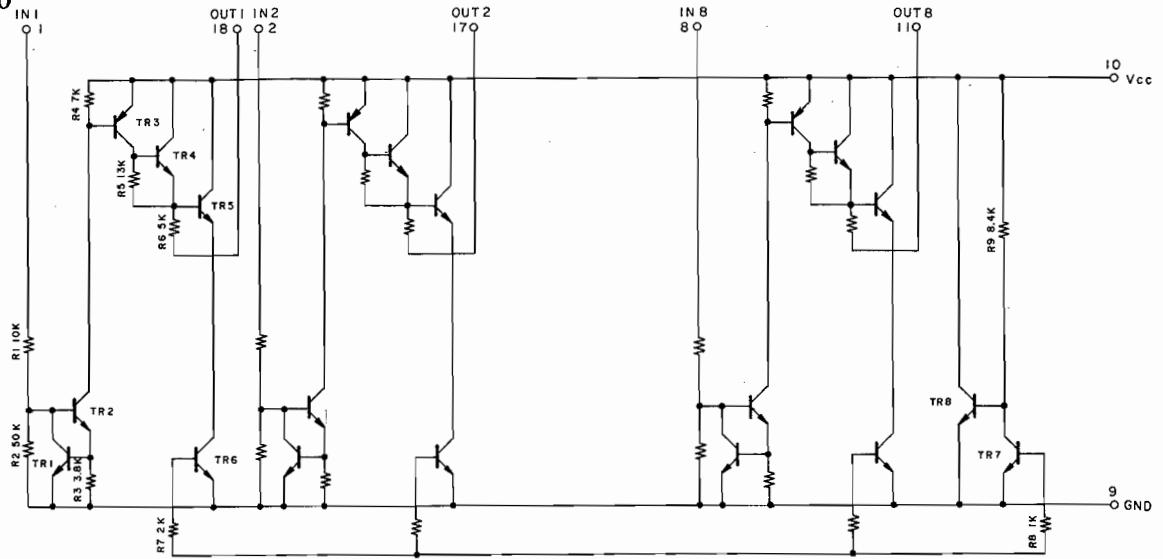

**LC4049**

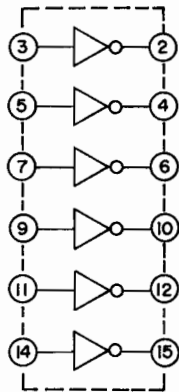

NC= Pin 13,16  
VSS= Pin 8  
VCC= Pin 1

**M5218L/LO**

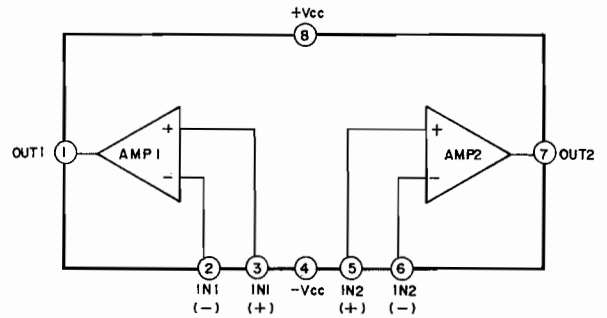

**TC4001BP**

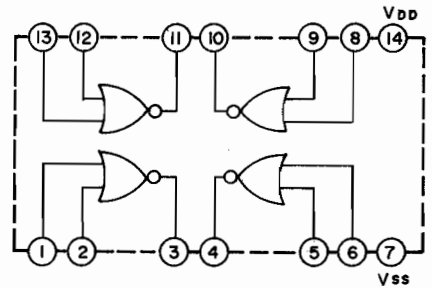

**LC4049B**

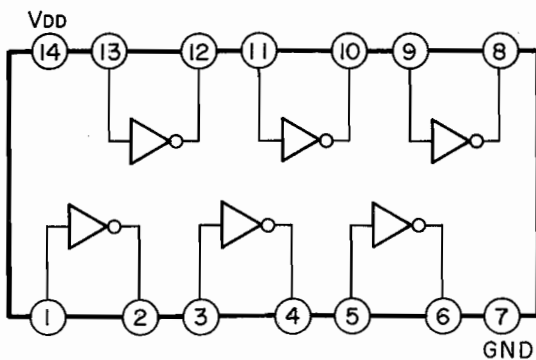

**LC4011B**

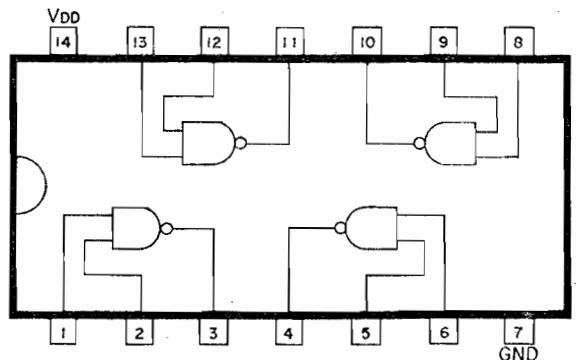

TC4052BP

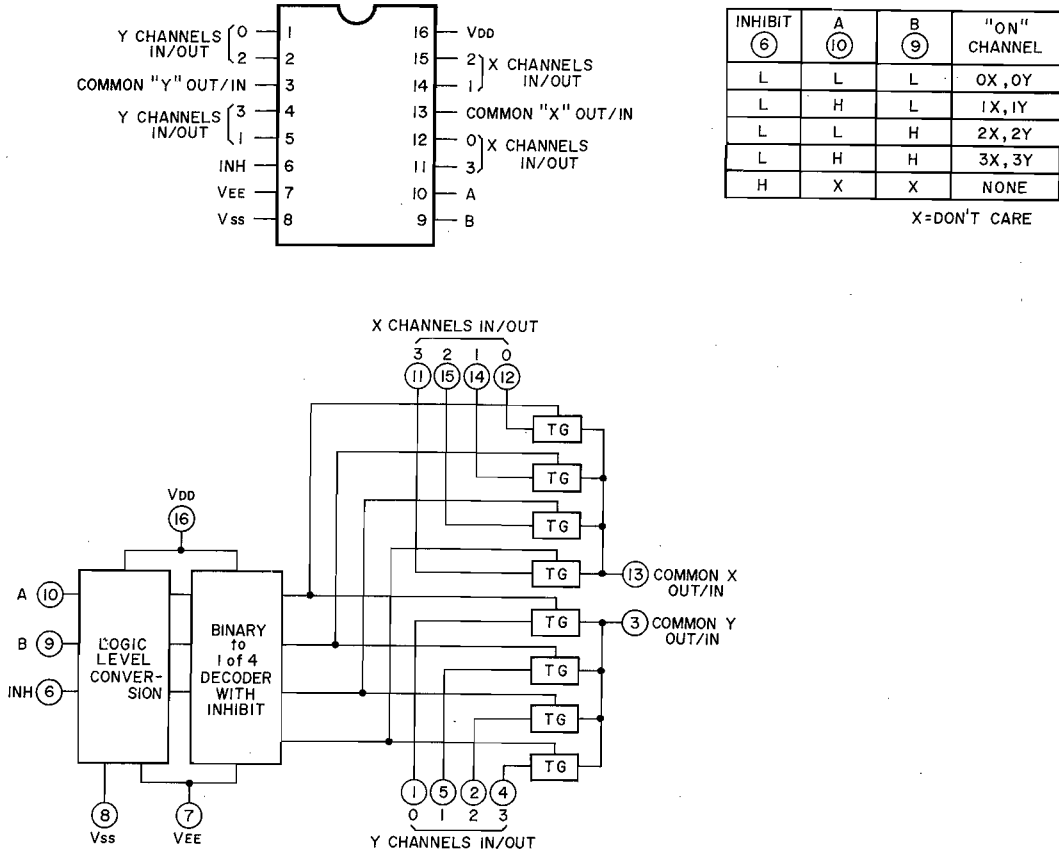

TC-9147P

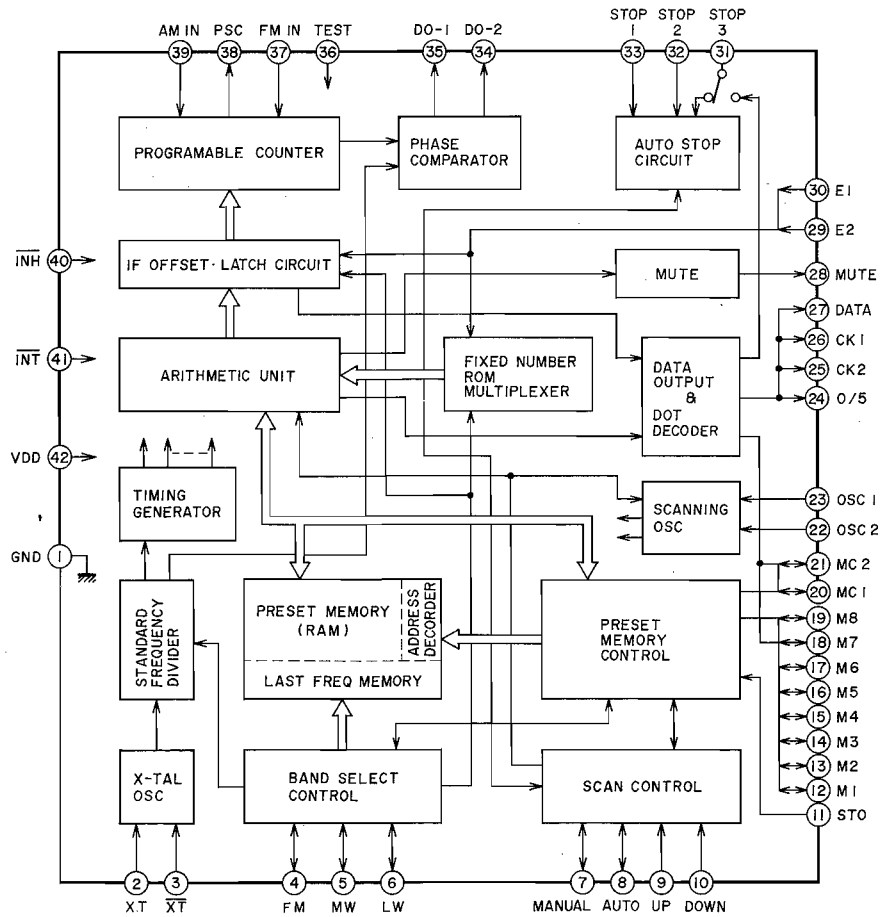

SCHEMATIC DIAGRAM AT-M5/L AM-M5/M7



TC9154P

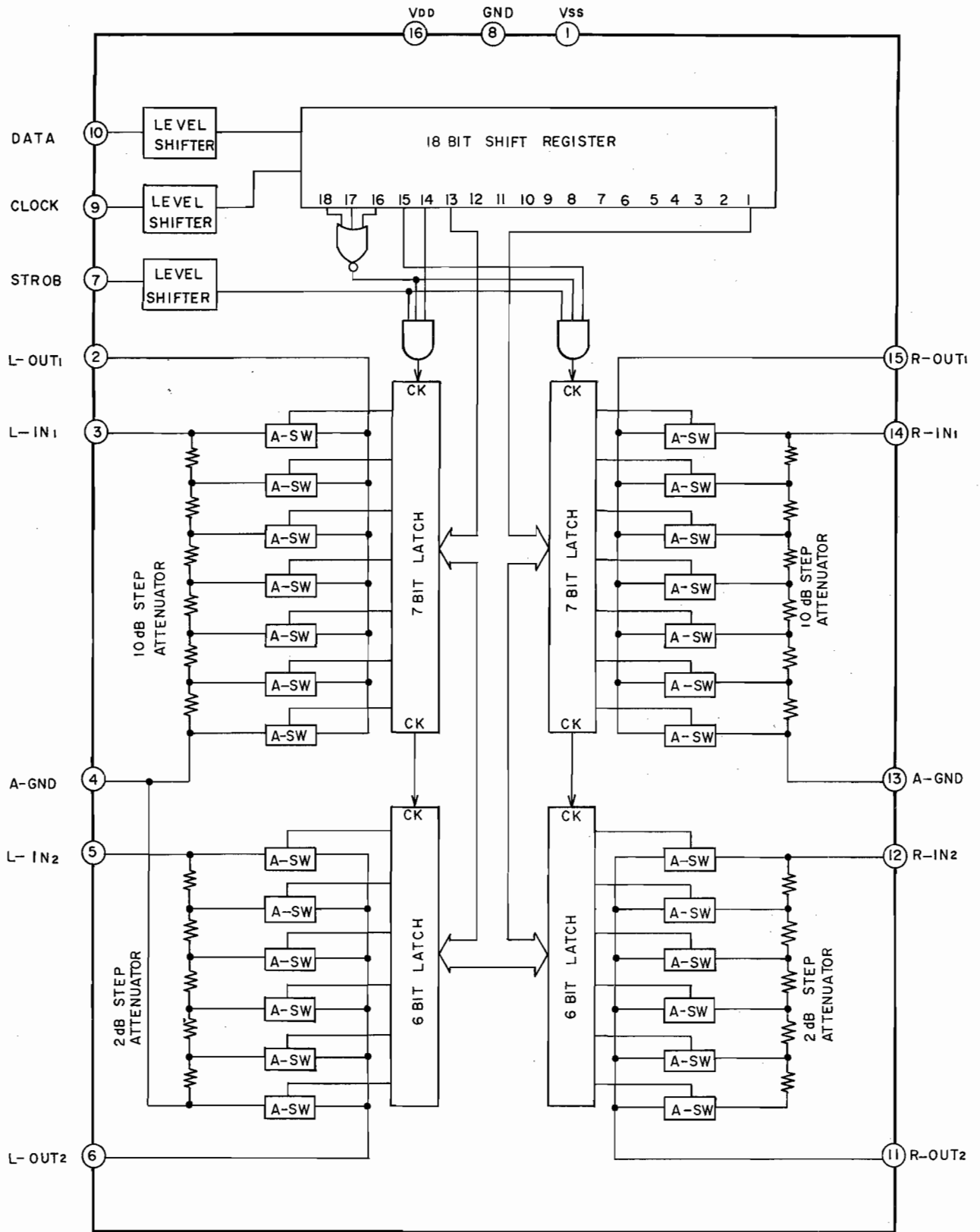

SCHEMATIC DIAGRAM AT-M5/L AM-M5/M7

TC9156P

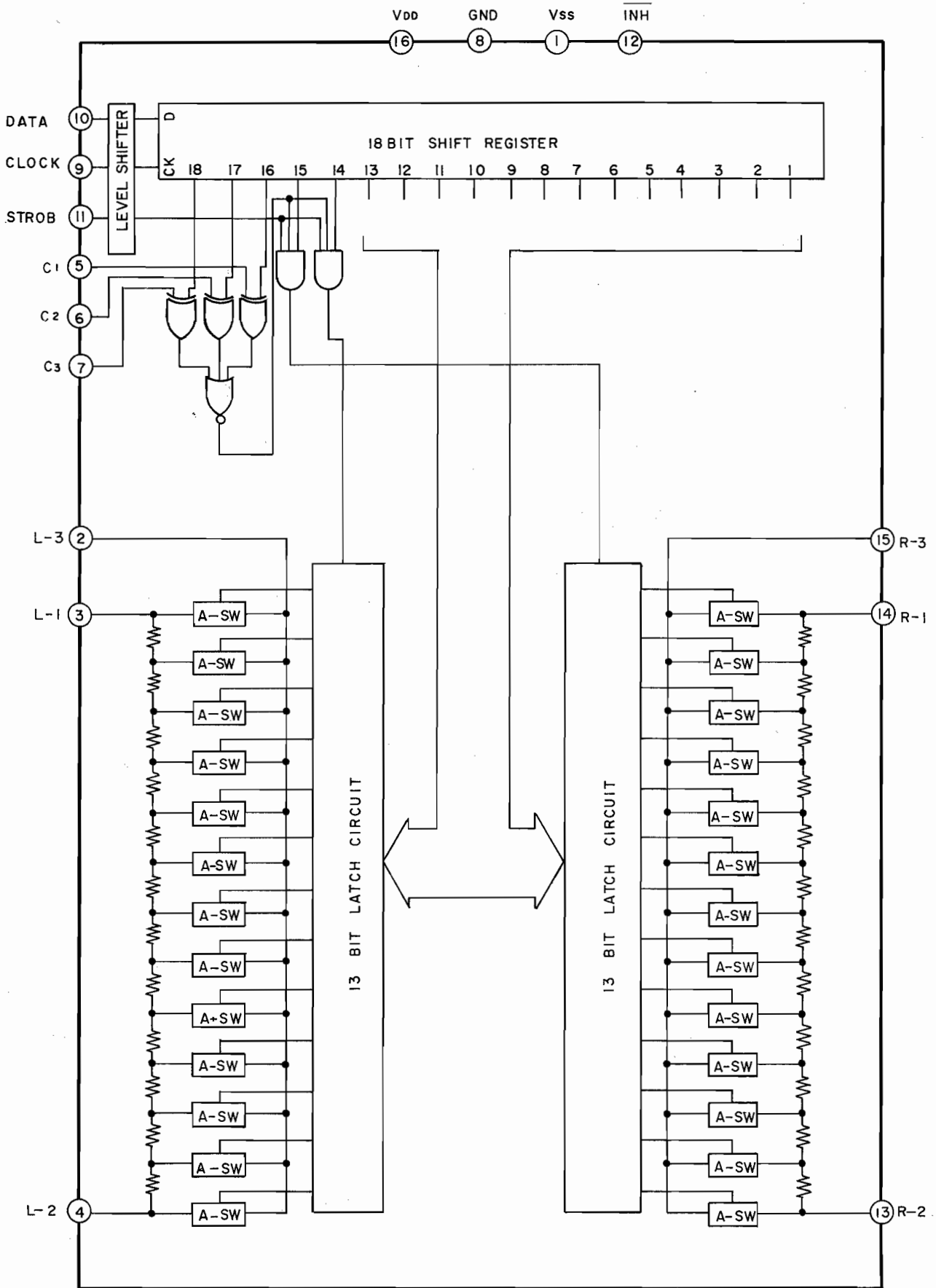

SCHMATIC DIAGRAM AT-M5/L AM-M5/M7

**TD6104P**

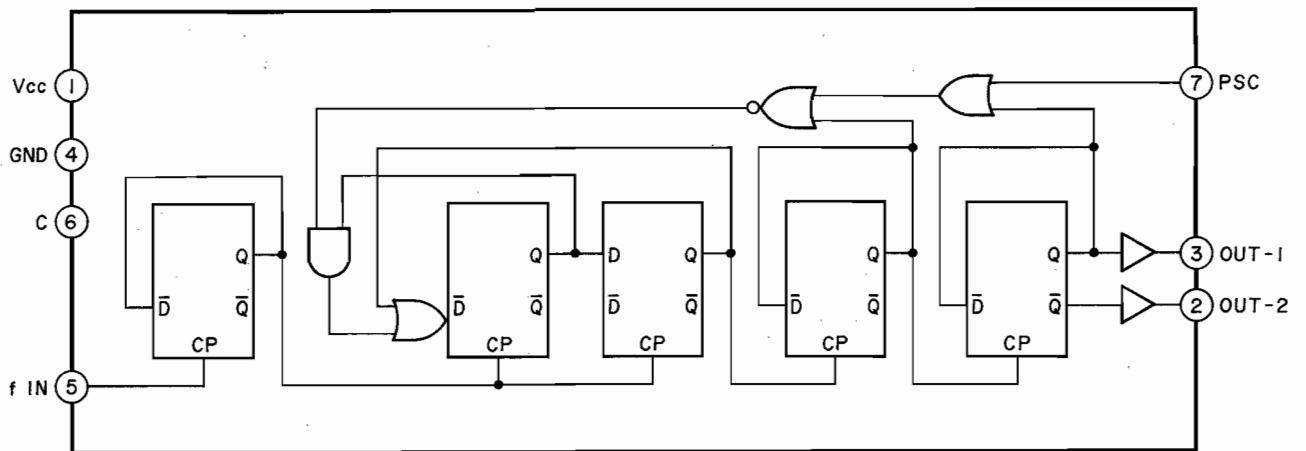

**TD6301P**

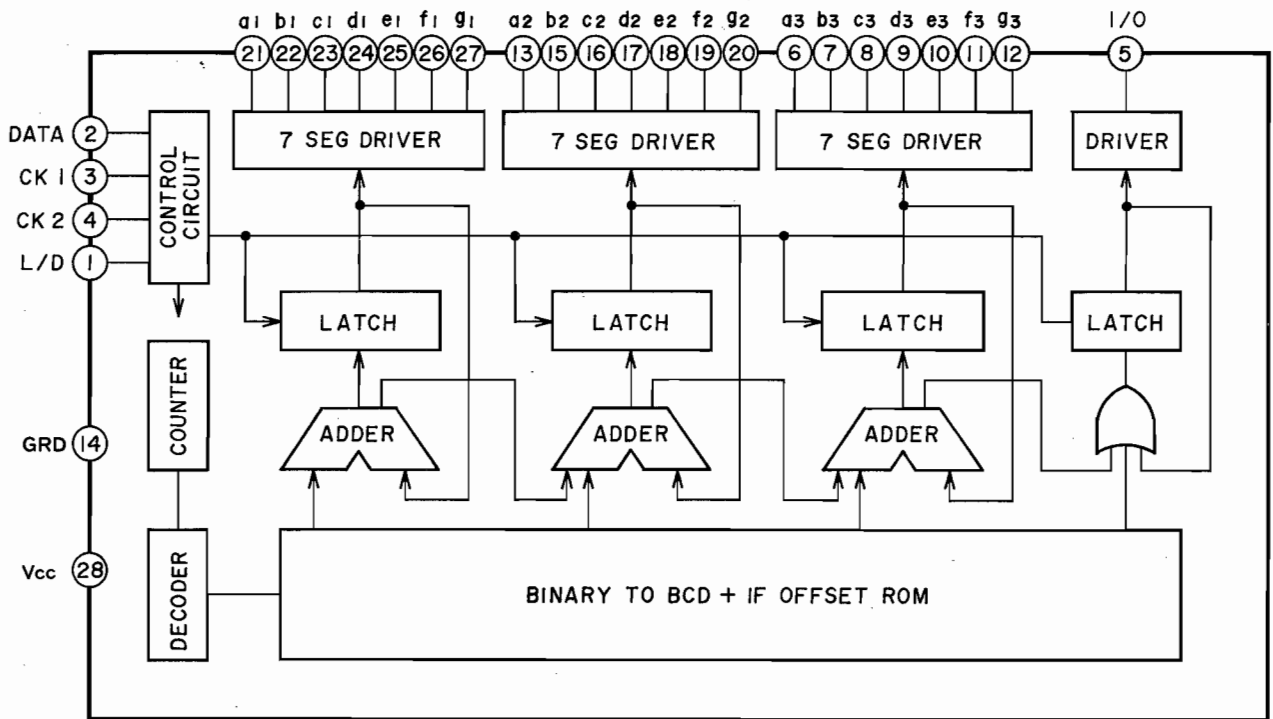

**STK 1050**

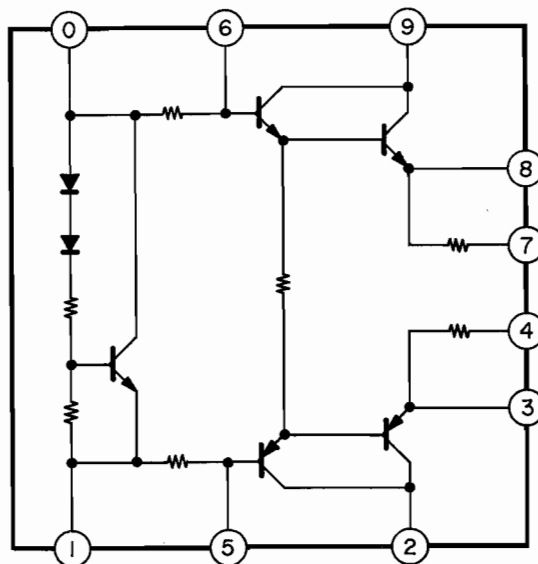

**TD6104P**

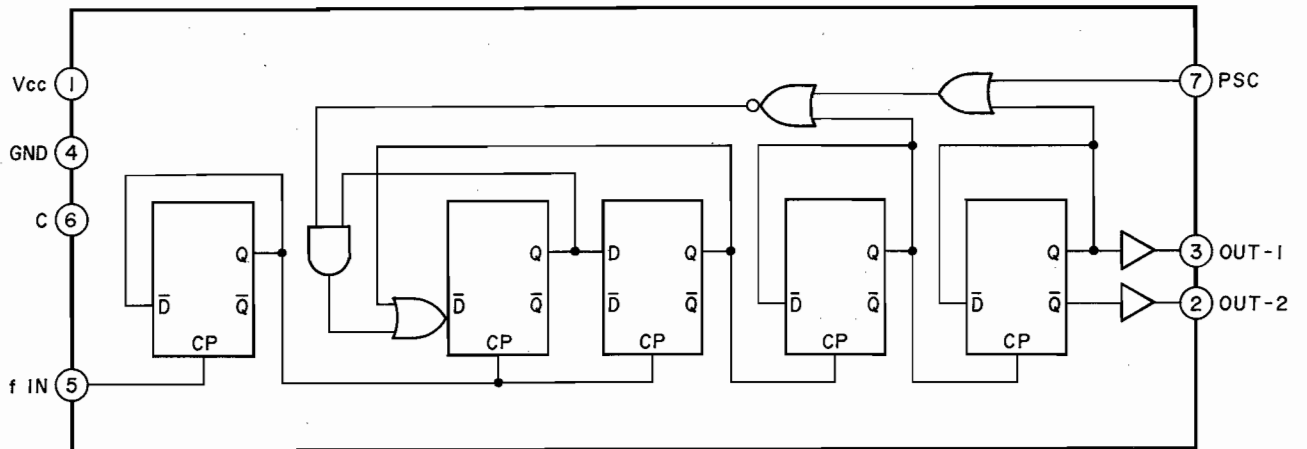

**TD6301P**

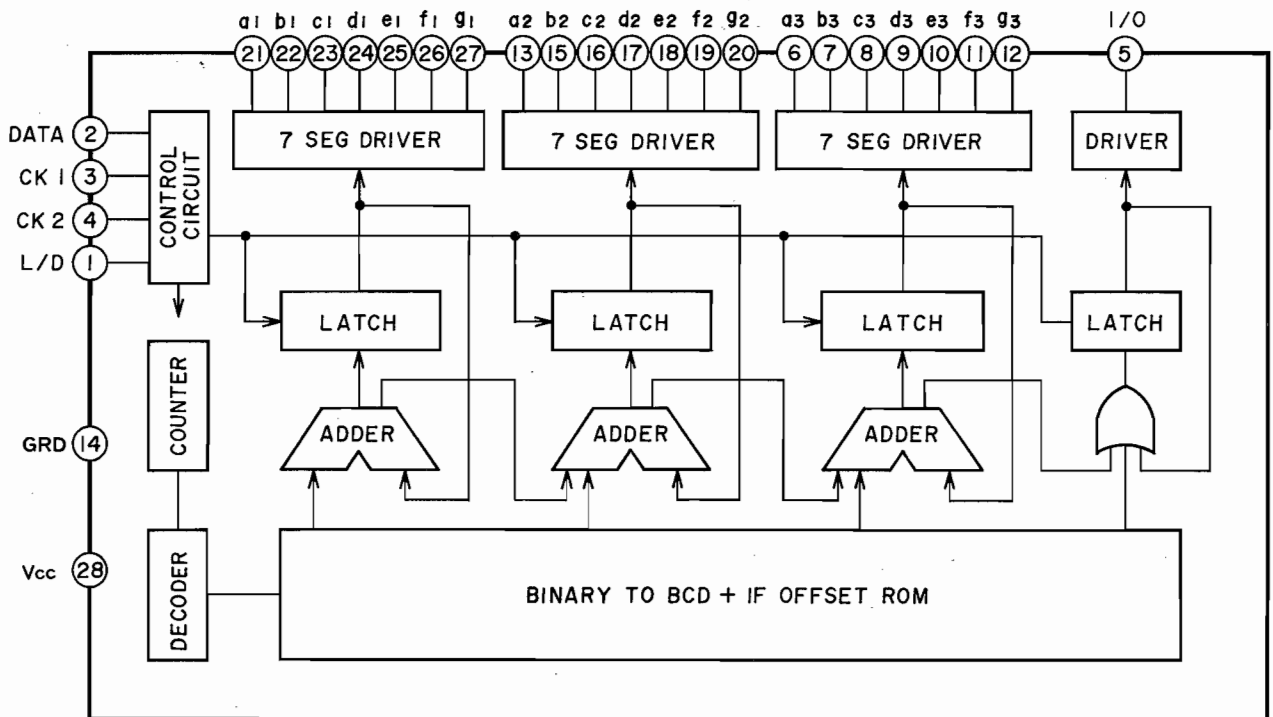

**STK 1050**

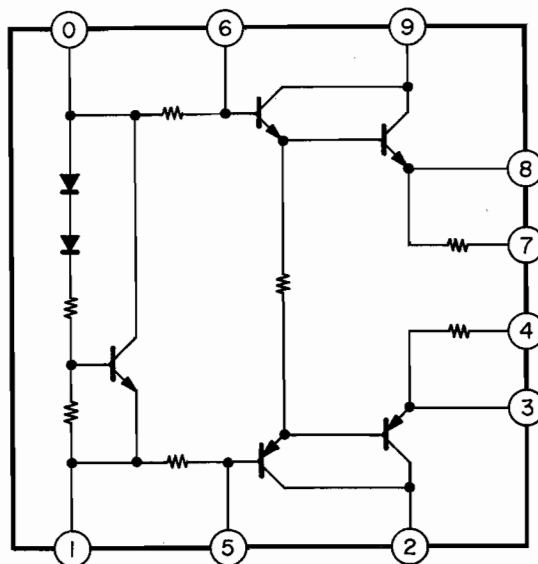

STK 3042Z

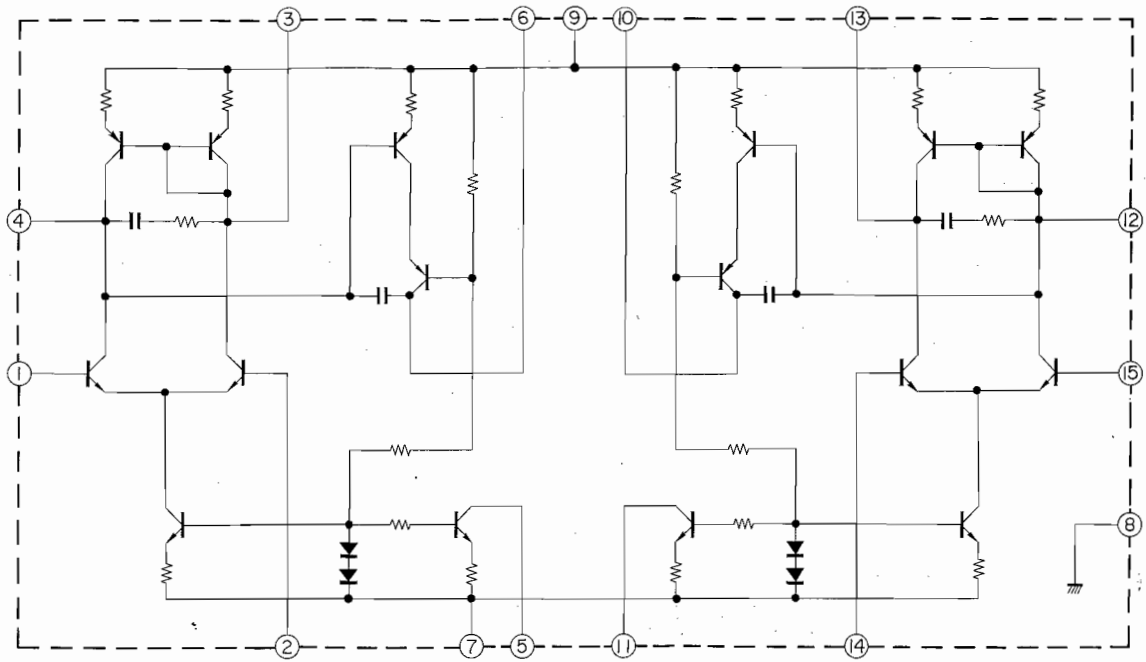

STK 4833

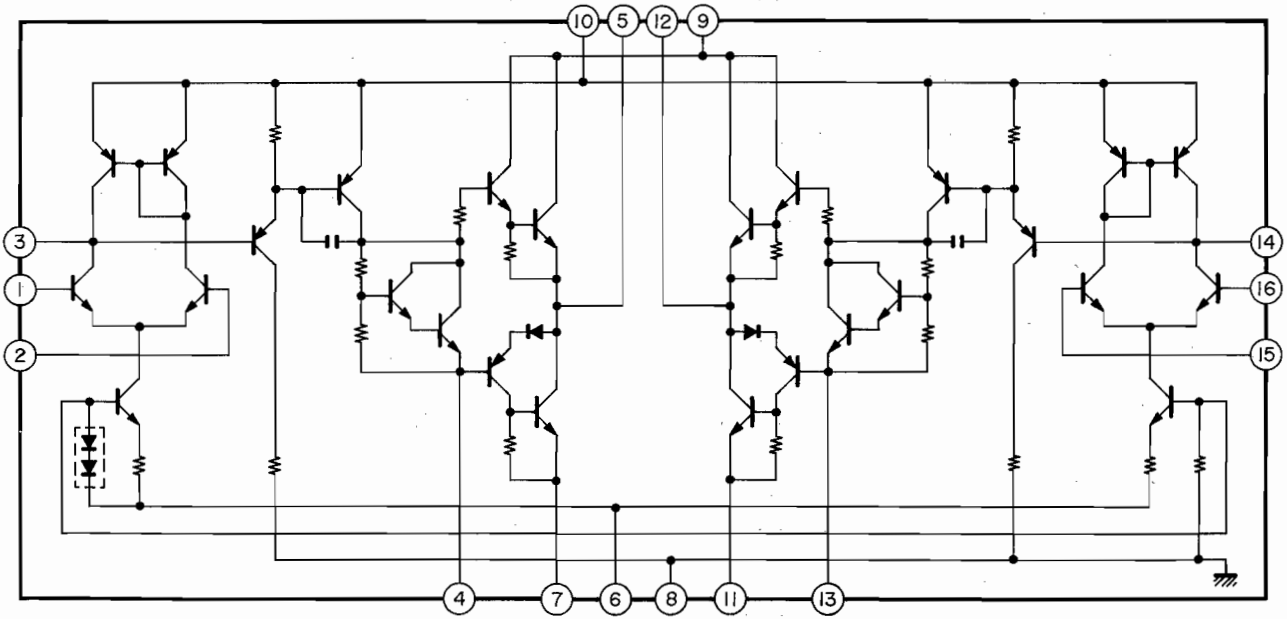

AT-M5

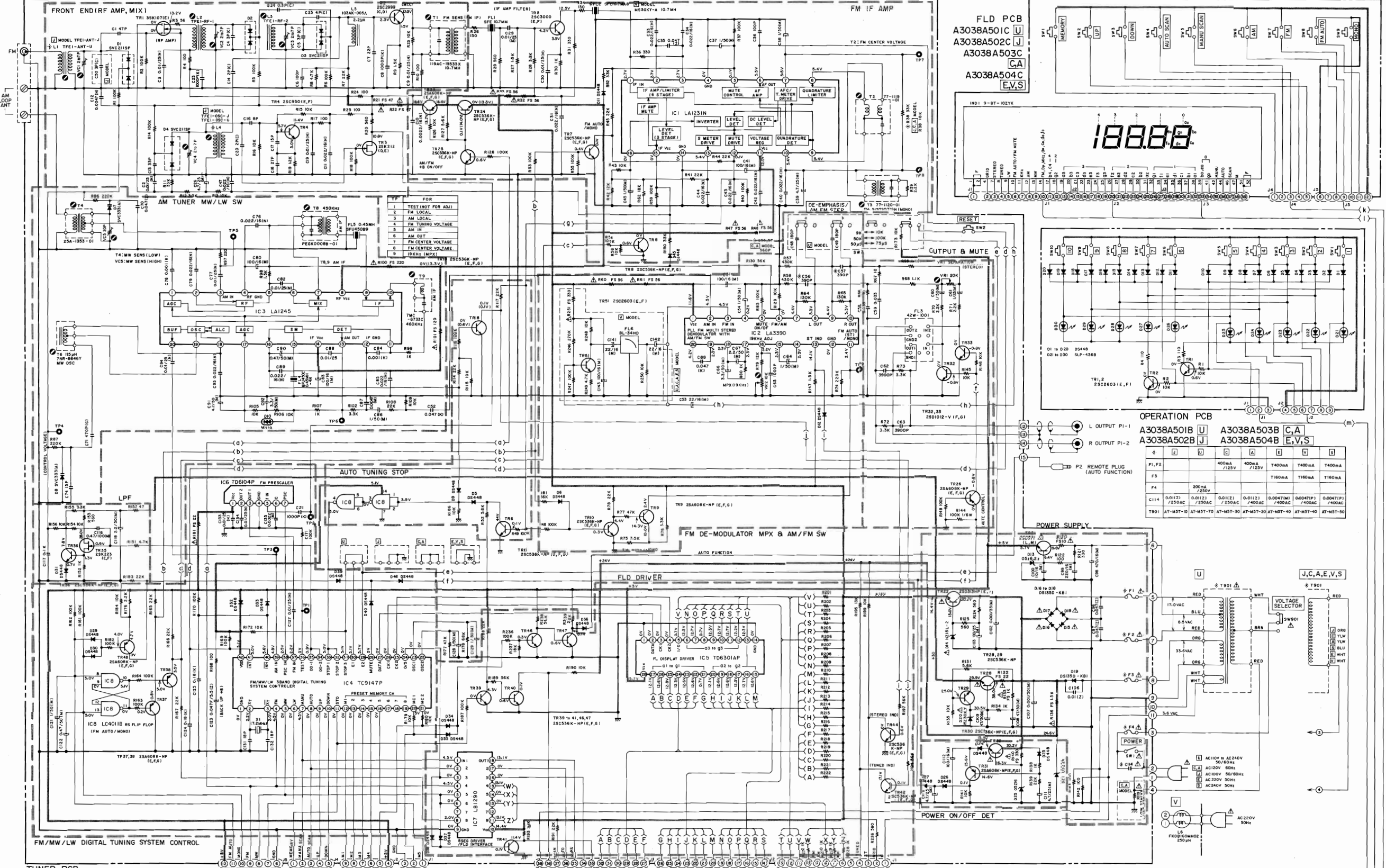

TUNER PCB  
 A3038A501A U A3038A503A C,A  
 A3038A502A U A3038A504A E,V,S

FLD PCB  
 A3038A501C U  
 A3038A502C U  
 A3038A503C C,A  
 A3038A504C E,V,S

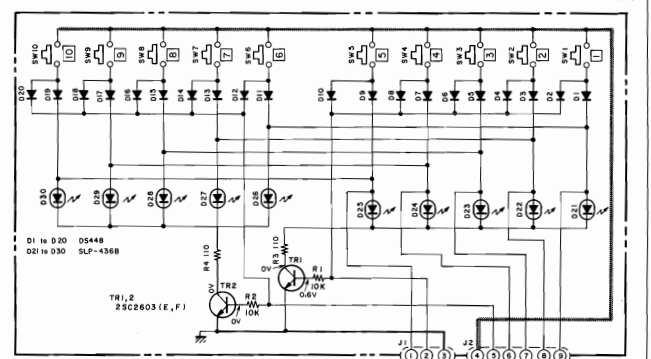
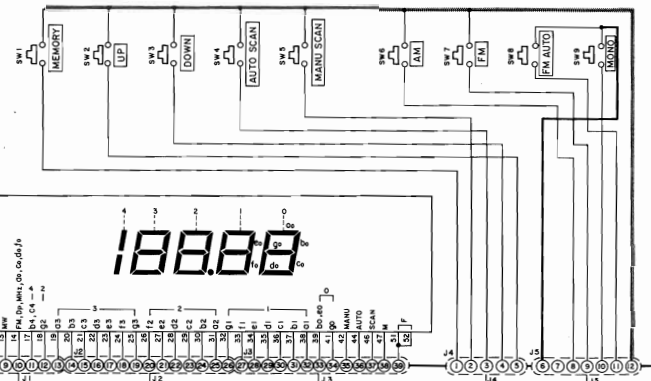

	A	B	C	D	E	F	G
F1,F2	400mA /125V	400mA /125V	1400mA	1400mA	1400mA	1400mA	1400mA
F3			T180mA	T180mA	T180mA	T180mA	T180mA
F4	300mA						
C114	0.01(2) /250AC	0.01(2) /250AC	0.01(2) /400AC	0.0047(M) /400AC	0.0047(M) /400AC	0.0047(M) /400AC	0.0047(M) /400AC
T901	AT-M5T-10	AT-M5T-10	AT-M5T-20	AT-M5T-20	AT-M5T-40	AT-M5T-40	AT-M5T-50

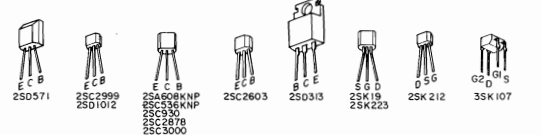
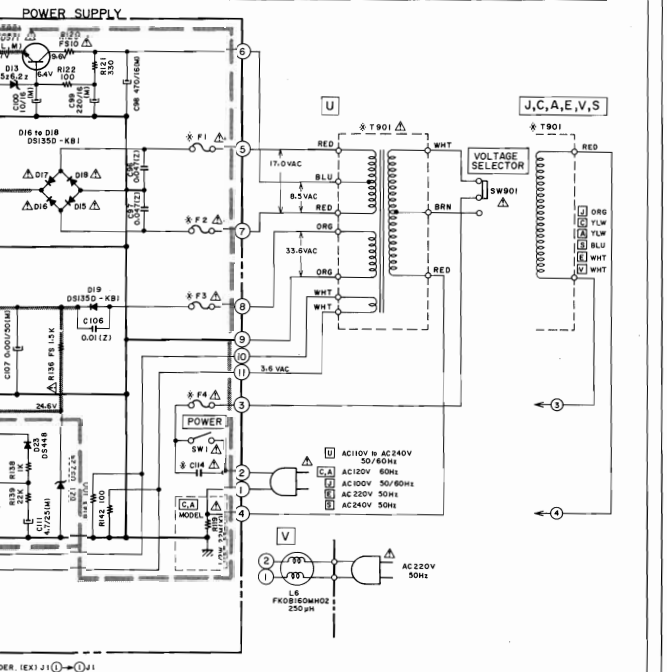

WARNING: INDICATES SAFETY CRITICAL COMPONENTS FOR CONTINUOUS SAFETY. REPLACE SAFETY CRITICAL COMPONENTS ONLY WITH MANUFACTURER'S RECOMMENDED PARTS.  
 AVERTISSEMENT: ΔΔΔ INDIQUE LES COMPOSANTS CRITIQUES DE SÉCURITÉ. POUR MAINTENIR LE DEGRÉ DE SÉCURITÉ DE L'APPAREIL, NE REMPLACER QUE DES PIÈCES RECOMMANDÉES PAR LE FABRICANT.

NOTE: UNLESS OTHERWISE SPECIFIED, ALL RESISTORS IN OHMS (AWW/LJ). ALL CAPACITORS IN μF 50 WV (VJ).

VOLTAGES ARE MEASURED AT FM MODE, AUTO FREQUENCY (90.0 MHz), TUNED.  
 VOLTAGES IN ( ) ARE MEASURED AT FM MODE, FREQUENCY (1420KHz), TUNED.

(TUNER)  
 AT-M5  
 SCHEMATIC DIAGRAM  
 No. 830212A

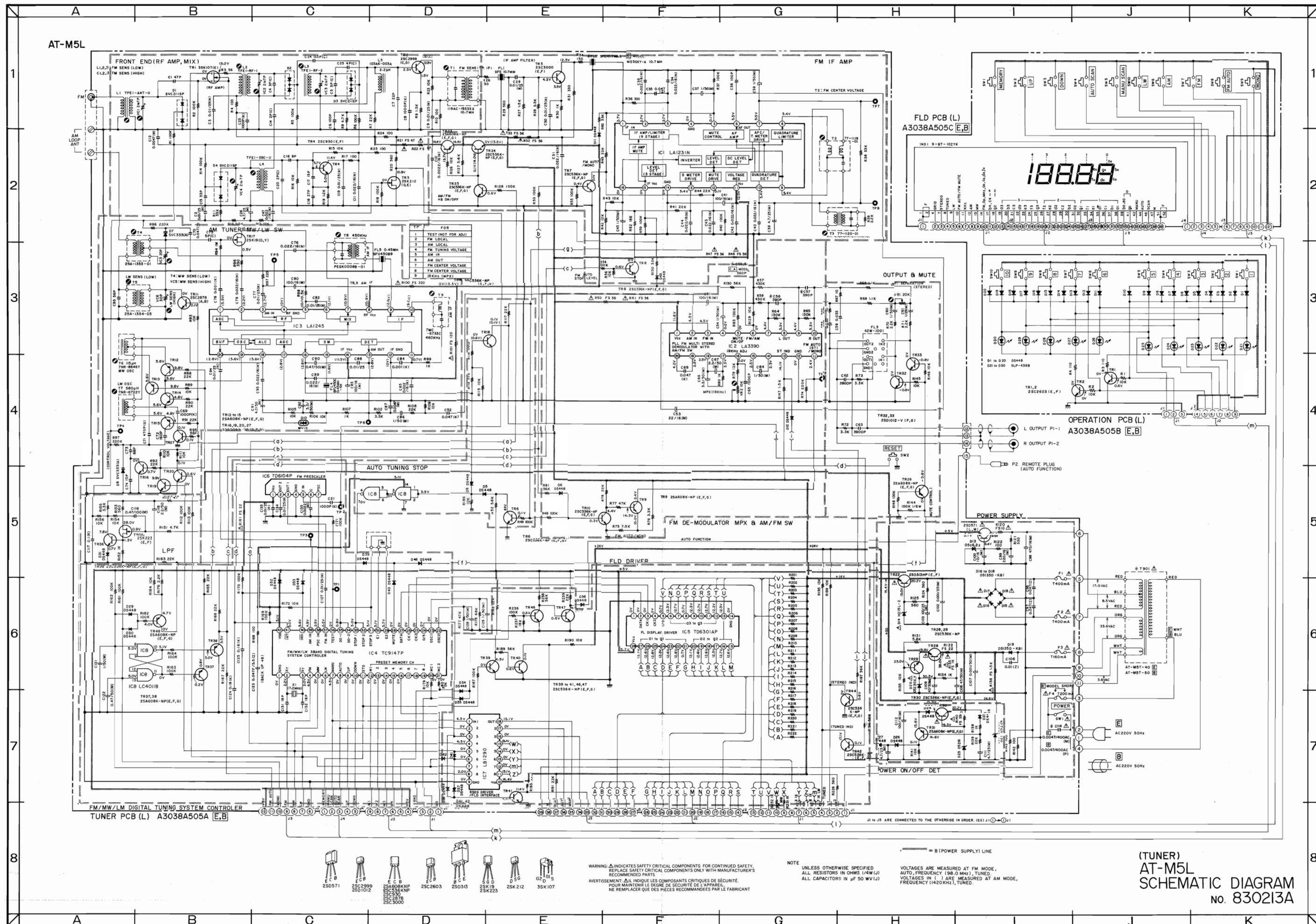

- 250571
- 250102
- 25C2999
- 25C3500
- 25C2603
- 25D313
- 25K119
- 25K229
- 25K212
- 35K107

WARNING: Δ INDICATES SAFETY CRITICAL COMPONENTS FOR CONTINUED SAFETY. REPLACE SAFETY CRITICAL COMPONENTS ONLY WITH MANUFACTURER'S RECOMMENDED PARTS.  
 AVERTISSEMENT: Δ IL INDIQUE LES COMPOSANTS CRITIQUES DE SÉCURITÉ. NE REMPLACEZ QUE DES PIÈCES RECOMMANDÉES PAR LE FABRICANT.

NOTE: UNLESS OTHERWISE SPECIFIED, ALL RESISTORS IN OHMS (W/J). ALL CAPACITORS IN pF 50 WV (J).

VOLTAGES ARE MEASURED AT FM MODE, AUTO, FREQUENCY (98.0 MHz), TUNED. VOLTAGES IN ( ) ARE MEASURED AT AM MODE, FREQUENCY (1420 kHz), TUNED.

(TUNER)  
 AT-M5L  
 SCHEMATIC DIAGRAM  
 No. 830213A

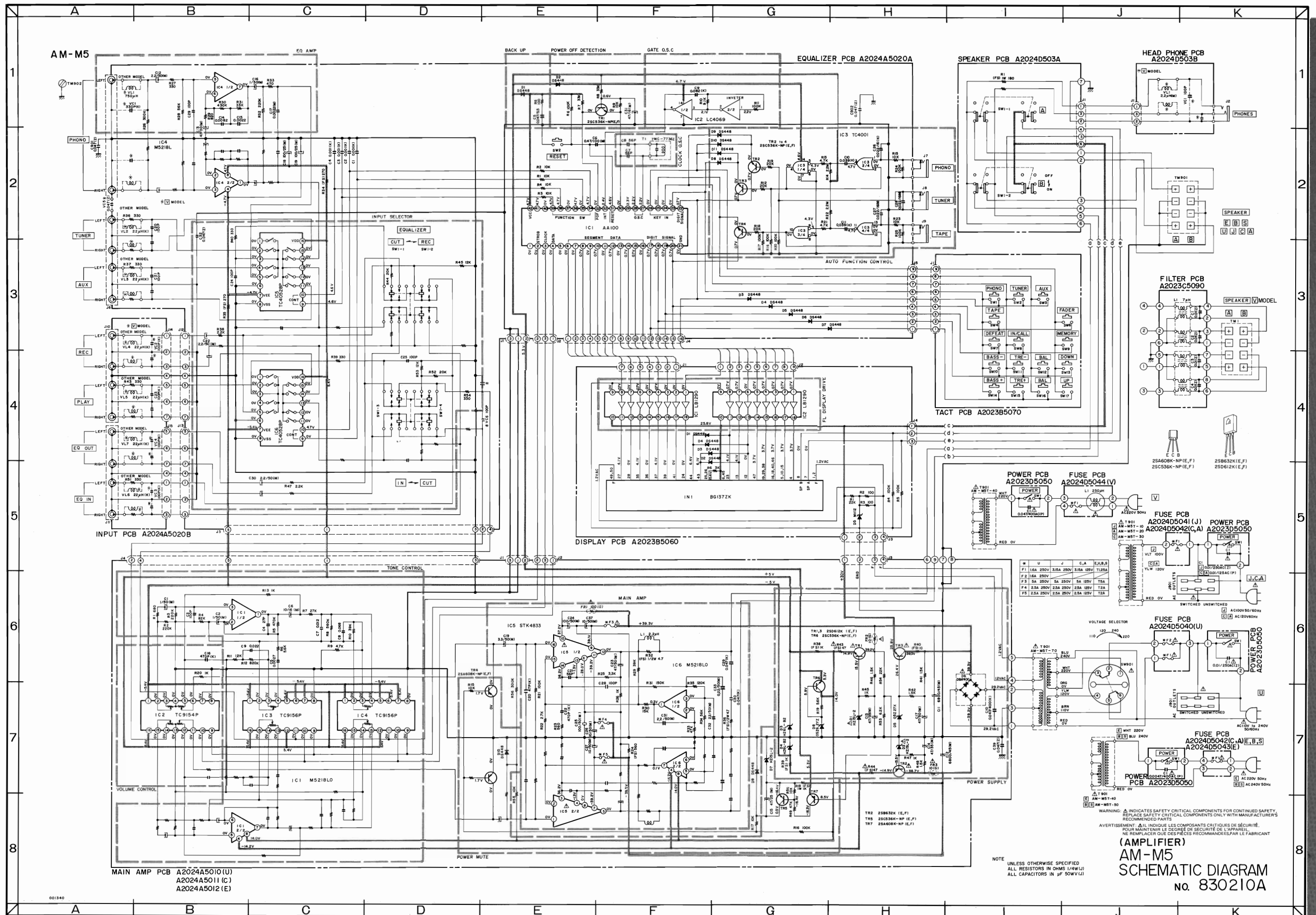

AM-M5  
MAIN AMP PCB A2024A5010(U)  
A2024A5011(C)  
A2024A5012(E)

NOTE  
UNLESS OTHERWISE SPECIFIED  
ALL RESISTORS IN OHMS (1/4W/1J)  
ALL CAPACITORS IN µF (50WV/1J)

### (AMPLIFIER) AM-M5 SCHEMATIC DIAGRAM No. 830210A

WARNING: ⚠ INDICATES SAFETY CRITICAL COMPONENTS FOR CONTINUED SAFETY. REPLACE SAFETY CRITICAL COMPONENTS ONLY WITH MANUFACTURER'S RECOMMENDED PARTS.  
AVERTISSEMENT: ⚠ IL INDIQUE LES COMPOSANTS CRITIQUES DE SÉCURITÉ. POUR MAINTENIR LE DEGRÉ DE SÉCURITÉ DE L'APPAREIL, NE REMPLACEZ QUE DES PIÈCES RECOMMANDÉES PAR LE FABRICANT.

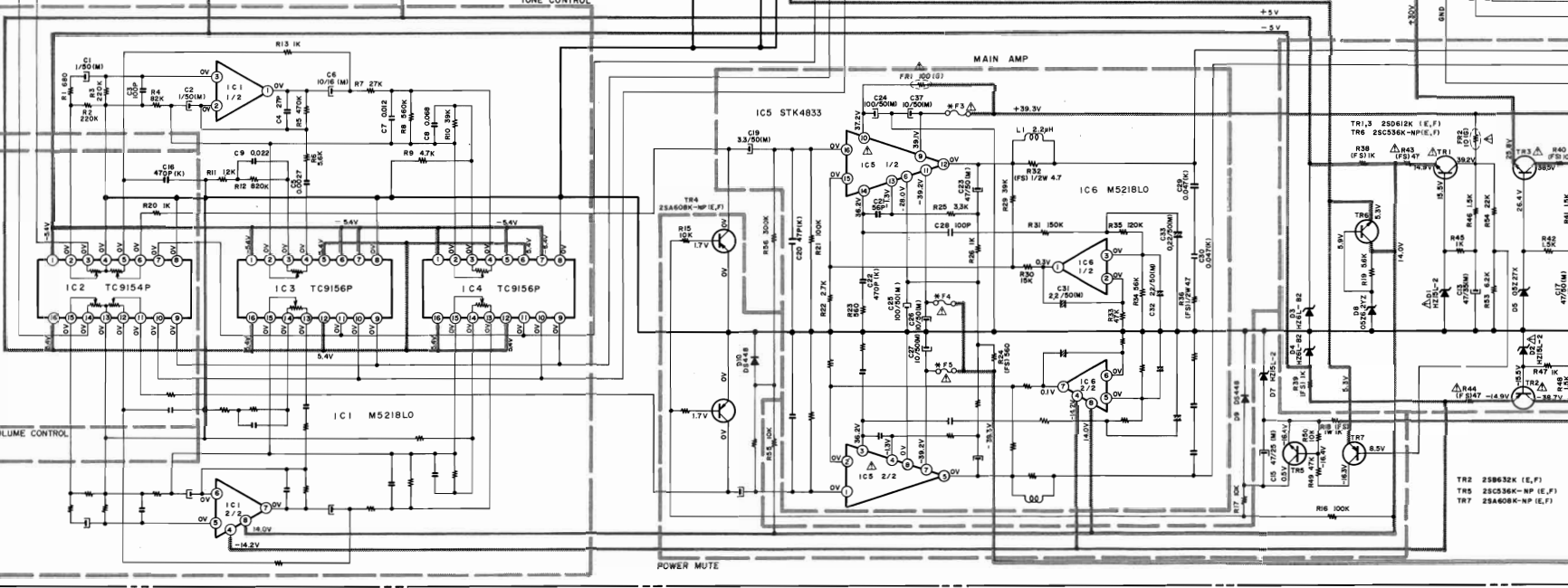
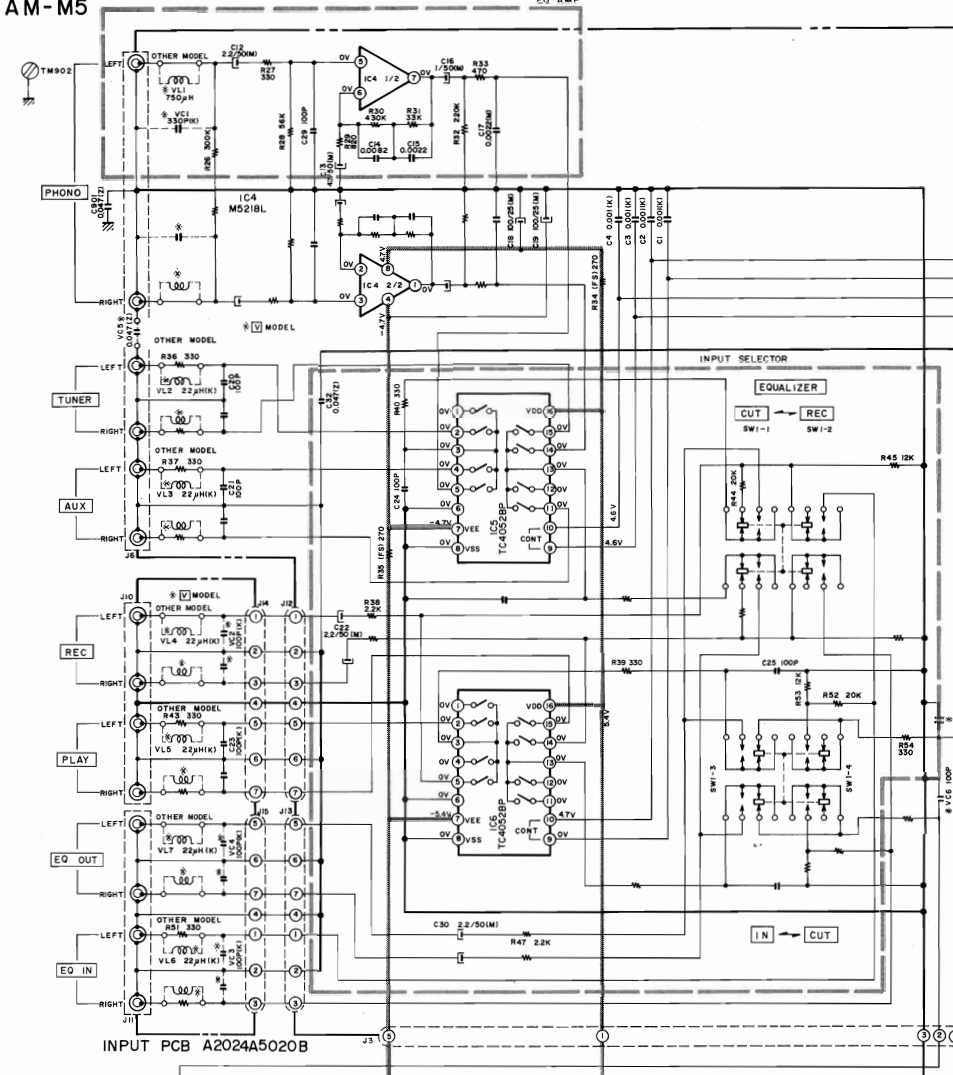
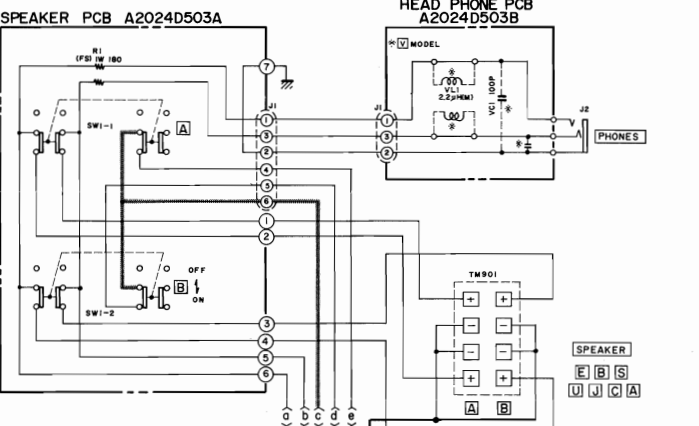
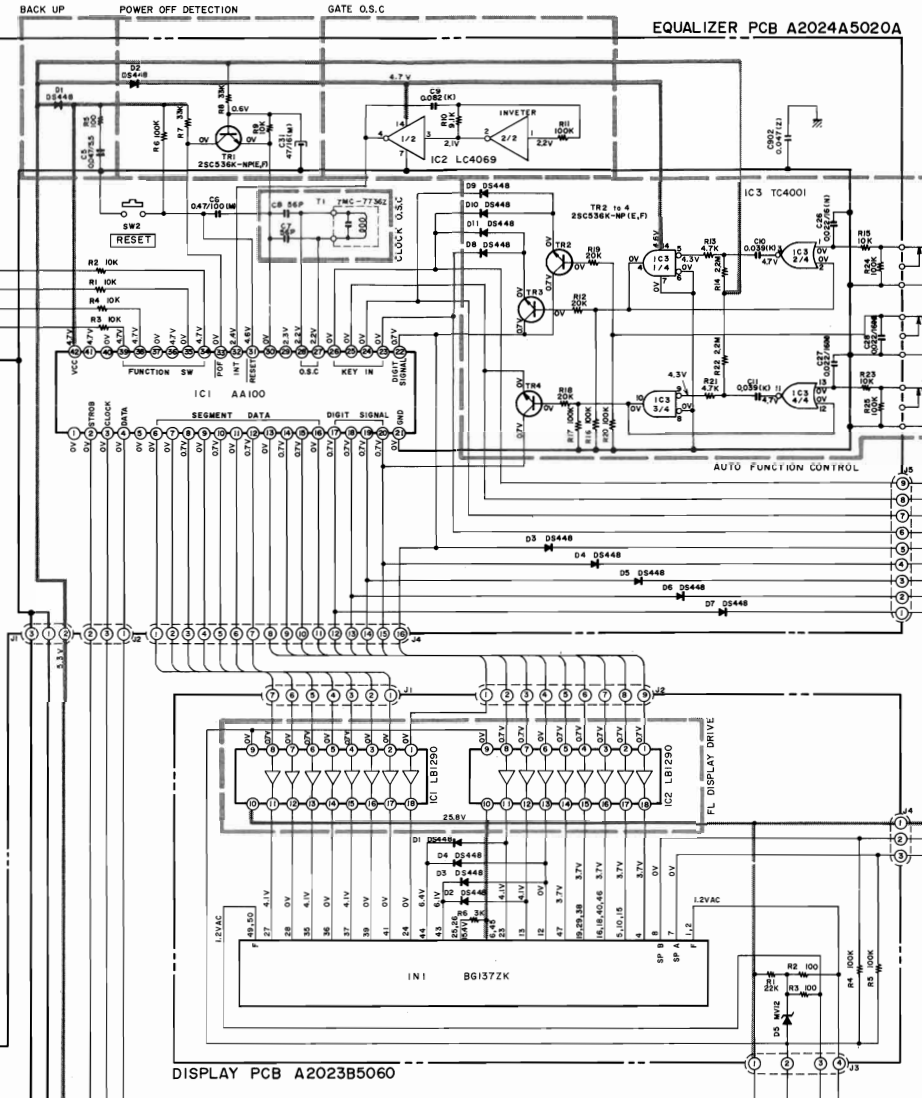
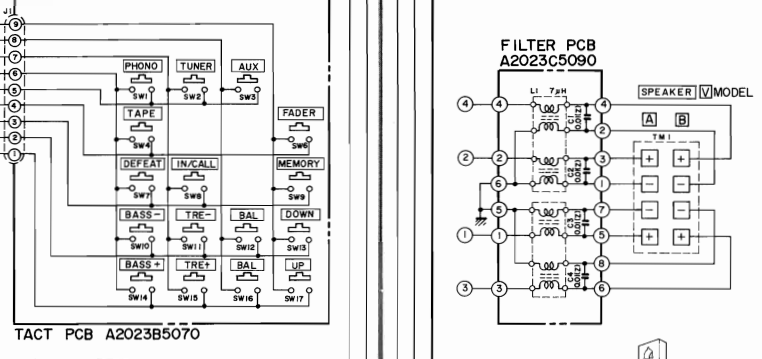
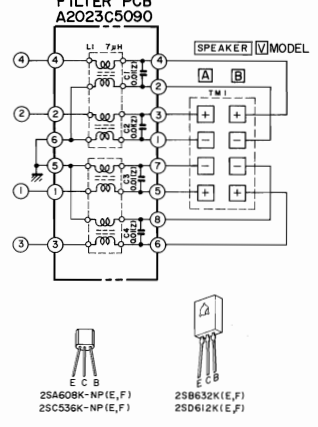
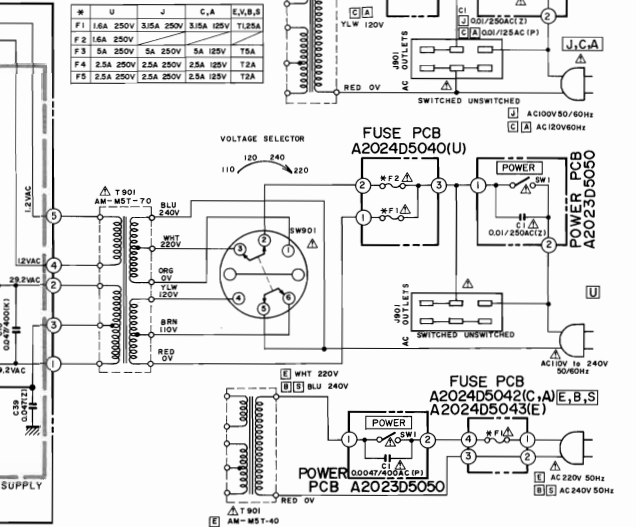



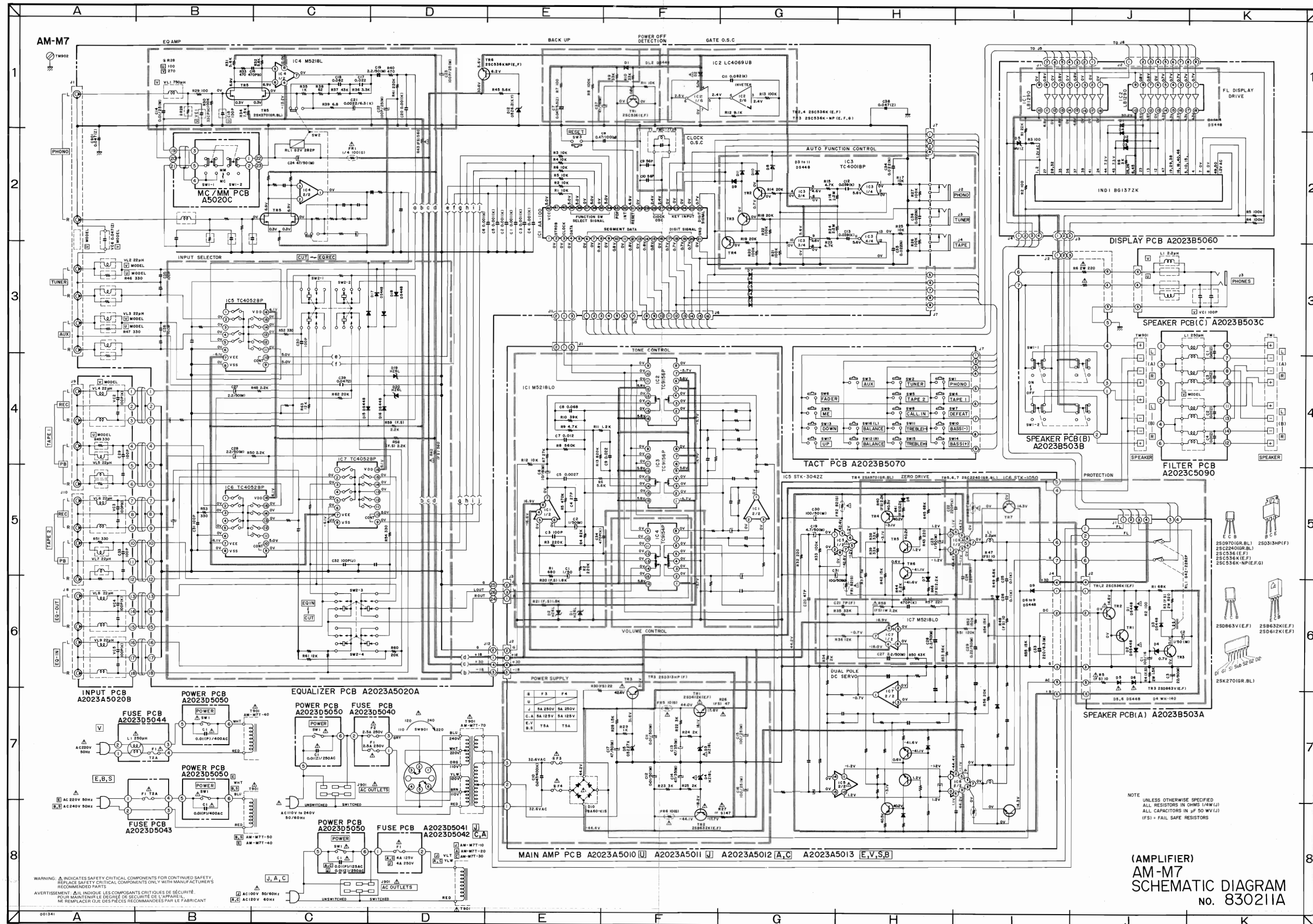

NOTE  
UNLESS OTHERWISE SPECIFIED  
ALL RESISTORS IN OHMS (1/4W (J))  
ALL CAPACITORS IN μF 50 WV (J)  
(FS) = FAIL SAFE RESISTORS

(AMPLIFIER)  
AM-M7  
SCHEMATIC DIAGRAM  
No. 830211A