

SERVICE MANUAL

PARTS LIST

AP-206

MODEL AP-306

AKAI

ALSO APPLICABLE TO BLACK MODEL

AP-206
AP-306



AP-206



AP-306

**AKAI DIRECT DRIVE TURNTABLE
AND
AKAI DIRECT DRIVE QUARTZ LOCK TURNTABLE**

MODEL **AP-206**

MODEL **AP-306**

ALSO APPLICABLE TO BLACK MODEL

SECTION 1	SERVICE MANUAL	3
SECTION 2	PARTS LIST	31
SECTION 3	SCHEMATIC DIAGRAM	48



SECTION 1

SERVICE MANUAL

TABLE OF CONTENTS

I. TECHNICAL DATA	4
1. MODEL AP-206/C	4
2. MODEL AP-306/C	5
II. DISMANTLING OF UNIT	6
III. CONTROLS	7
1. MODEL AP-206/C	7
2. MODEL AP-306/C	8
IV. PRINCIPAL PARTS LOCATION	9
1. MODEL AP-206/C	9
2. MODEL AP-306/C	10
V. BLOCK DIAGRAM	11
1. MODEL AP-206/C	11
2. MODEL AP-306/C	11
VI. CIRCUIT OPERATION	12
1. GENERAL	12
2. SERVO CIRCUIT	12
3. STROBE LIGHT CIRCUIT	13
VII. MECHANICAL ADJUSTMENT	14
1. STYLUS PRESSURE ADJUSTMENT	14
2. OVER HANG ADJUSTMENT	15
3. SLEEVE POSITION ADJUSTMENT	16
4. PU PLATE ADJUSTMENT	16
5. LIFTER HEIGHT ADJUSTMENT	17
6. AUTOMATIC RETURN POSITION ADJUSTMENT	17
VIII. ELECTRICAL ADJUSTMENT	18
1. DIRECT DRIVE P.C BOARD ADJUSTMENT	18
2. PLL P.C BOARD ADJUSTMENT	19
IV. CLASSIFICATION OF VARIOUS P.C BOARDS	21
1. P.C BOARD TITLE AND IDENTIFICATION NUMBER	21
2. COMPOSITION OF VARIOUS P.C BOARDS	22

I. TECHNICAL DATA

1. MODEL AP-206/C

TURNTABLE	314 mm aluminum alloy die-cast
DRIVE SYSTEM	Direct drive, Auto-return
MOTOR	DC Servo Motor
SPEED & PITCH CONTROL	33-1/3 and 45 rpm $\pm 2.5\%$
SPEED ACCURACY	1,000 Hz $\pm 0.15\%$
WOW AND FLUTTER	0.035% (DIN), 0.025% (JIS)
RUMBLE	Better than 49 dB (DIN A), 70 dB (DIN B)
TONE ARM	Static-balanced type with Anti-skating Adjuster
ARM LENGTH	220 mm
STYLUS PRESSURE ADJUSTMENT RANGE	0 to 3 grams
APPLICABLE CARTRIDGE WEIGHT	4 to 12 grams
ARM LIFTER	Oil-damped
OVERHANG	15 mm
OFFSET ANGLE	22° 30'
HORIZONTAL TRACKING ERROR ANGLE	$\pm 2^\circ$
SHELL WEIGHT	7.8 grams
CARTRIDGE	(AP-206C only: Model AP-206 does not include cartridge) Induced magnet type
CARTRIDGE WEIGHT	6.4 grams
FREQUENCY RESPONSE	25 Hz to 30,000 Hz
OUTPUT VOLTAGE	5 mV
CHANNEL SEPARATION	More than 23 dB
OPTIMAL STYLUS PRESSURE	2 grams
DYNAMIC COMPLIANCE	8 x 10 ⁻⁶ cm/dyn vertical 8 x 10 ⁻⁶ cm/dyn horizontal
POWER REQUIREMENTS	120V, 60 Hz for U.S.A. and Canada 220V, 50 Hz for European countries except U.K. 240V, 50 Hz for U.K. and Australia 110 to 120V, 220 to 240V switchable 50/60 Hz for other countries
DIMENSIONS	440(W) x 158(H) x 350(D) mm
WEIGHT	7.4 kg

STANDARD ACCESSORIES

45 rpm Adapter	1
Minus driver	1
Operator's Manual	1

* For improvement purposes, specifications and design are subject to change without notice.

2. MODEL AP-306/C

TURNTABLE	314 mm aluminum alloy die-cast
DRIVE SYSTEM	Quartz Lock Direct Drive, Auto-Return
MOTOR	DC Servo Motor
SPEED & PITCH CONTROL	33-1/3 and 45 rpm $\pm 2.5\%$
SPEED ACCURACY	1,000 Hz $\pm 0.08\%$
WOW AND FLUTTER	0.035% (DIN), 0.025% (JIS)
RUMBLE	Better than 49 dB (DIN A), 70 dB (DIN B)
MOMENT OF INTERIA	230 kg.cm ²
TONE ARM	Static-balanced type with Anti-skating Adjuster
ARM LENGTH	220 mm
STYLUS PRESSURE ADJUSTMENT RANGE	0 to 3 grams
APPLICABLE CARTRIDGE WEIGHT	4 to 12 grams
ARM LIFTER	Oil-damped
OVERHANG	15 mm
OFFSET ANGLE	22° 30'
HORIZONTAL TRACKING ERROR ANGLE	$\pm 2^\circ$
SHELL WEIGHT	7.8 grams
CARTRIDGE	(AP-306C only: Model AP-306 does not include cartridge) Induced magnet type
CARTRIDGE WEIGHT	6.4 grams
FREQUENCY RESPONSE	25 Hz to 30,000 Hz
OUTPUT VOLTAGE	5 mV
CHANNEL SEPARATION	More than 23 dB
OPTIMAL STYLUS PRESSURE	2 grams
DYNAMIC COMPLIANCE	8 $\times 10^{-6}$ cm/dyn vertical 8 $\times 10^{-6}$ cm/dyn horizontal
POWER REQUIREMENTS	120V, 60 Hz for U.S.A. and Canada 220V, 50 Hz for European countries except U.K. 240V, 50 Hz for U.K. and Australia 110 to 120V, 220 to 240V switchable 50/60 Hz for other countries
DIMENSIONS	440(W) \times 158(H) \times 350(D) mm
WEIGHT	7.9 kg

STANDARD ACCESSORIES

45 rpm Adapter	1
Minus driver	1
Operator's Manual	1

* For improvement purposes, specifications and design are subject to change without notice.

II. DISMANTLING OF UNIT

In case of trouble, etc. necessitating dismantling, please dismantle in the order shown in the photographs. Reassemble in reverse order.

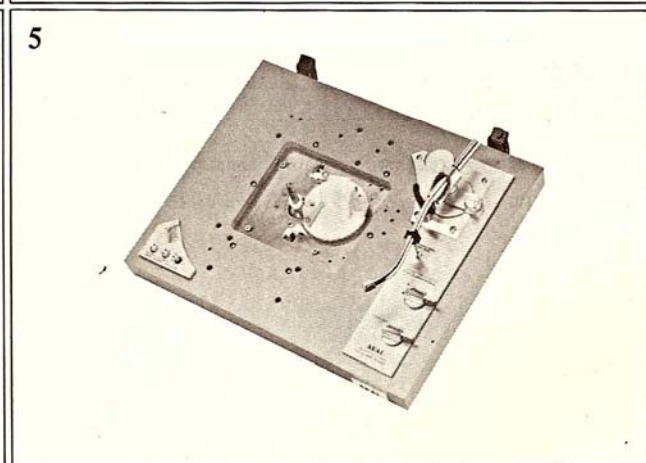
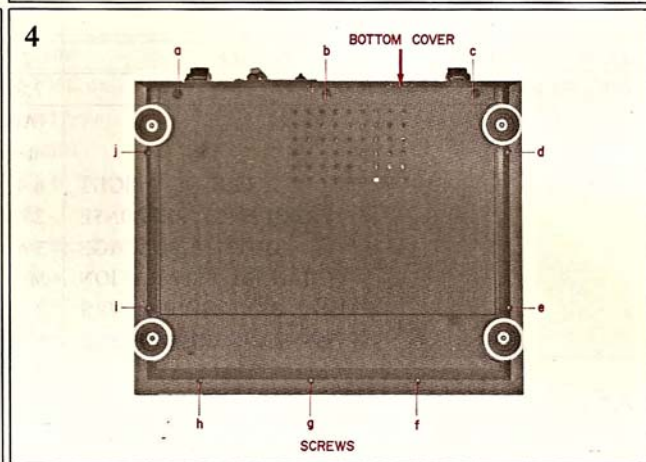

NOTE: Photos of dismantling are those of AP-306, but the order applies to AP-306C and AP-206/C also.

III. CONTROLS

1. MODEL AP-206/C

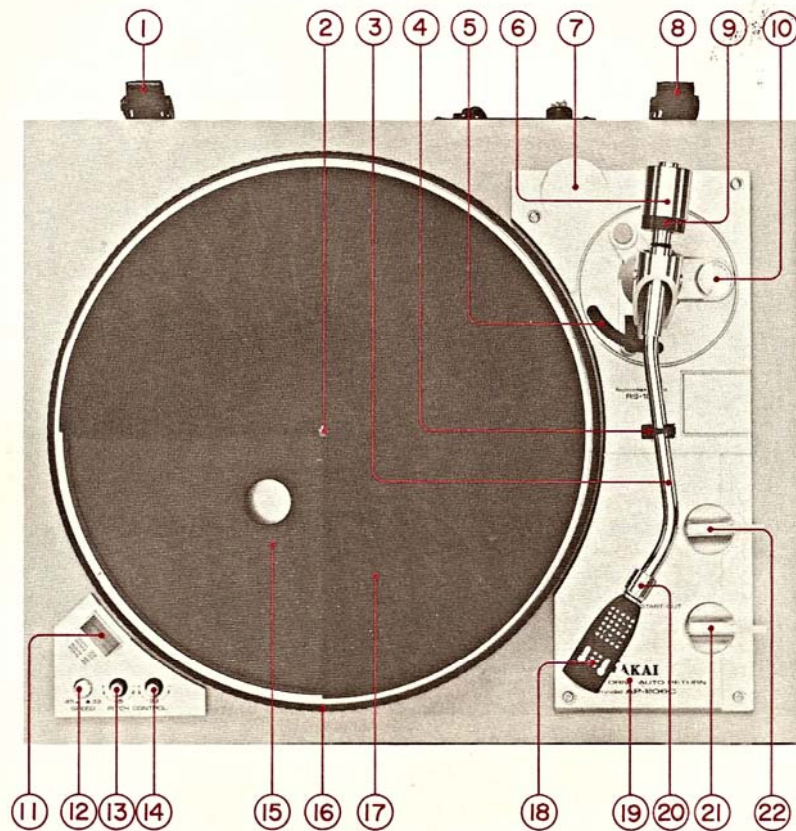

Fig. 1

- | | |
|--|---|
| 1. HINGE | 13. PITCH CONTROL (45 rpm) |
| 2. SPINDLE | 14. PITCH CONTROL (33-1/3 rpm) |
| 3. TONE ARM | 15. TURNTABLE PLATTER |
| 4. TONE ARM REST | 16. STROBE MARKINGS |
| 5. TONE ARM LIFTER | 17. RUBBER MAT |
| 6. MAIN WEIGHT | 18. CARTRIDGE SHELL |
| 7. 45 rpm ADAPTER HOLDER | 19. CARTRIDGE SHELL FINGER LEVER |
| 8. HINGE | 20. LOCKING NUT |
| 9. STYLUS PRESSURE SCALE RING | 21. START/CUT LEVER |
| 10. ANTI-SKATING ADJUSTER | 22. TONE ARM LIFTER LEVER
(▼ to Lower ▲ to Lift) |
| 11. BUILT-IN STROBE LIGHT | |
| 12. 45/33-1/3 rpm Speed Selector (▲ 33 ▼ 45) | |

NOTE: AP-206 is not equipped with a cartridge.

2. MODEL AP-306/C

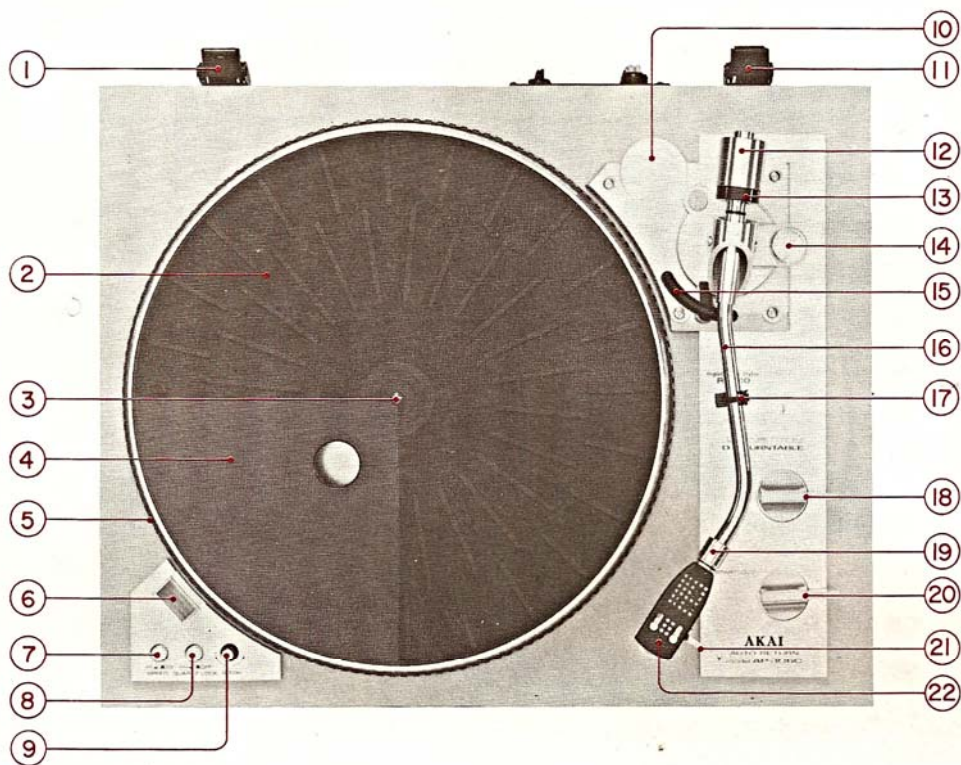

Fig. 2

- | | |
|---------------------------|----------------------------------|
| 1. HINGE | 12. MAIN WEIGHT |
| 2. RUBBER MAT | 13. STYLUS PRESSURE SCALE RING |
| 3. SPINDLE | 14. ANTI-SKATING ADJUSTER |
| 4. TURNTABLE PLATTER | 15. TONE ARM LIFTER |
| 5. STROBE MARKINGS | 16. TONE ARM REST |
| 6. BUILT-IN STROBE LIGHT | 17. TONE ARM |
| 7. SPEED SELECTOR SWITCH | 18. TONE ARM LIFTER LEVER |
| 8. QUARTZ LOCK SWITCH | 19. LOCKING NUT |
| 9. PITCH CONTROL | 20. START/CUT LEVER |
| 10. 45 rpm ADAPTER HOLDER | 21. CARTRIDGE SHELL FINGER LEVER |
| 11. HINGE | 22. CARTRIDGE SHELL |

NOTE: AP-306 is not equipped with a cartridge.

IV. PRINCIPAL PARTS LOCATION

1. MODEL AP-206/C

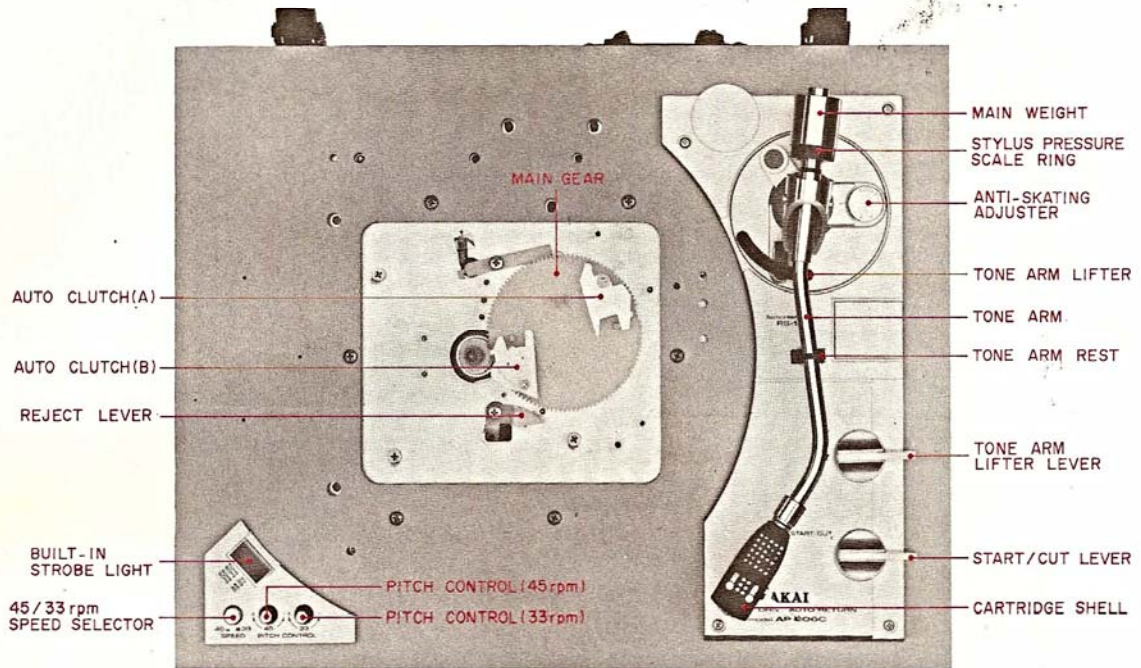

Fig. 3 AP-206/C Top View with Dust Cover Removed

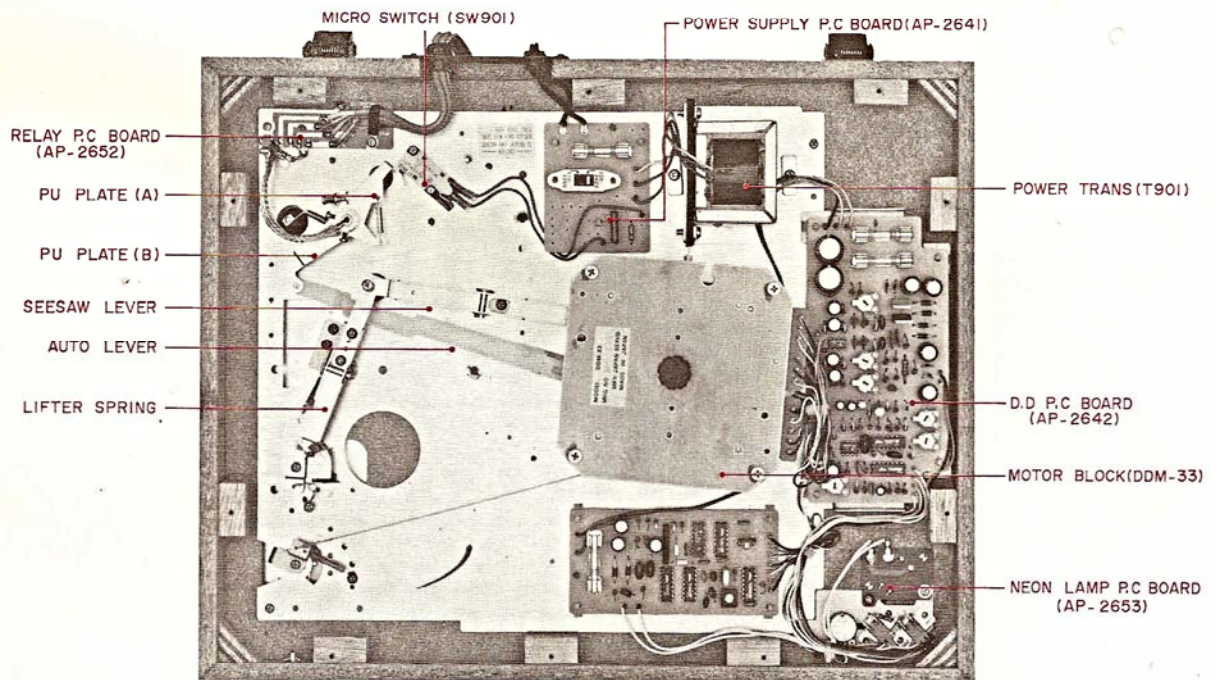

Fig. 4 AP-206/C Bottom View with Bottom Case Removed

2. MODEL AP-306/C

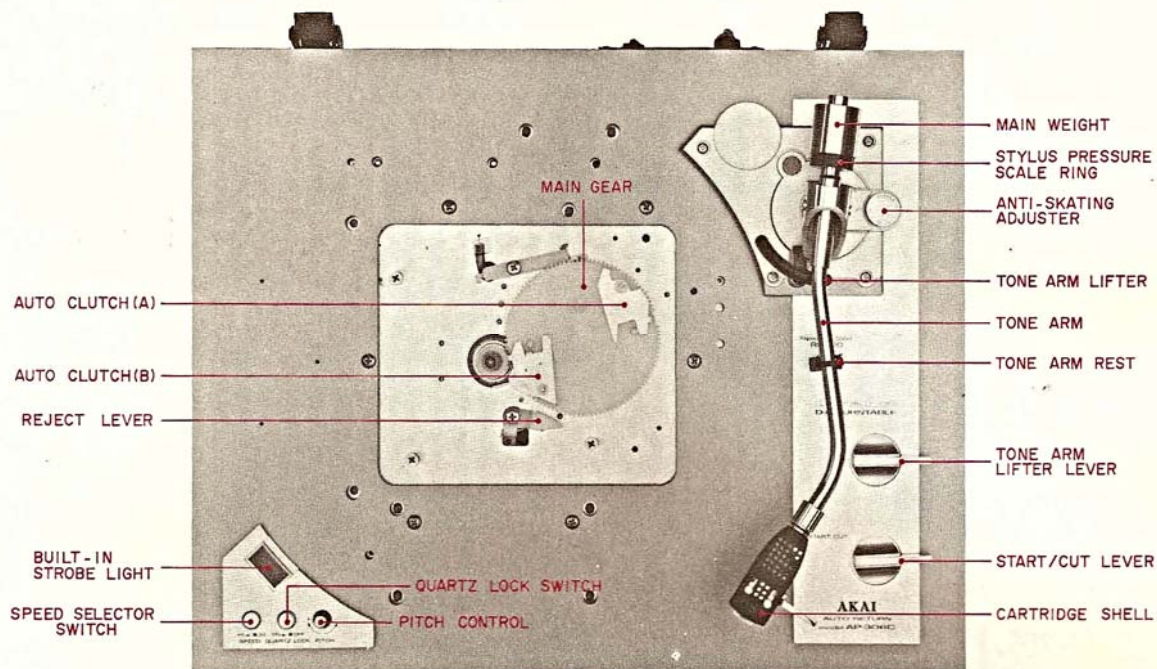

Fig. 5 AP-306/C, Top View with Dust Cover Removed

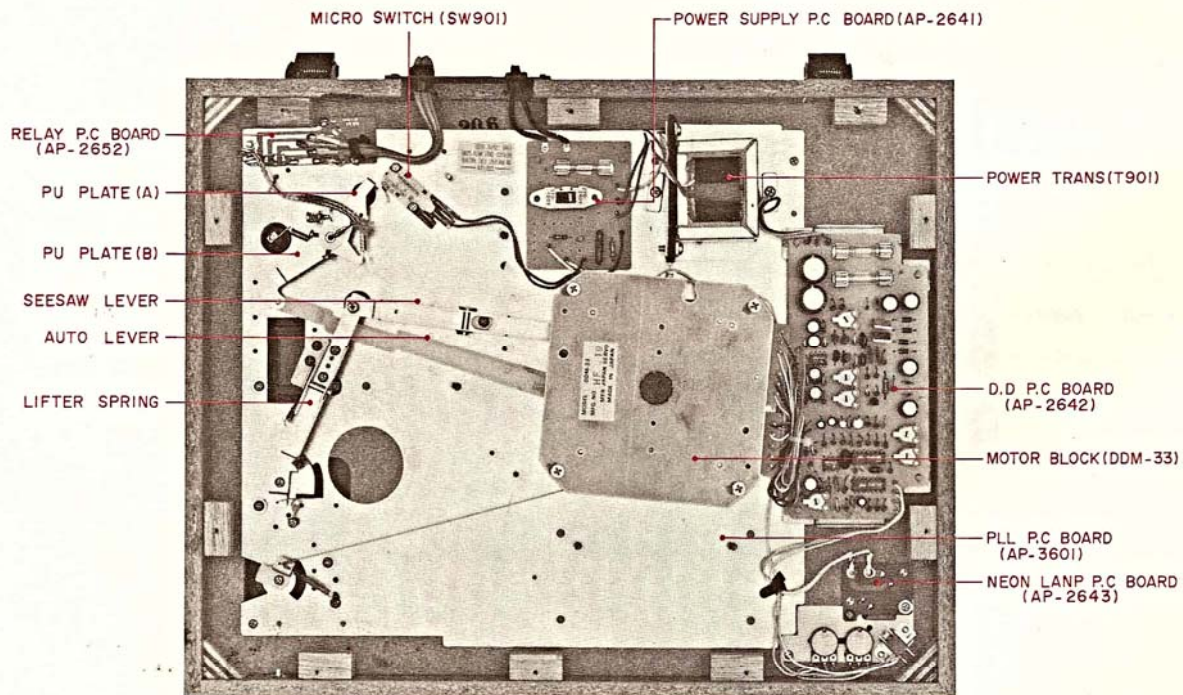

Fig. 6 AP-306/C Bottom View with Bottom Case Removed

V. BLOCK DIAGRAM

1. MODEL AP-206/C

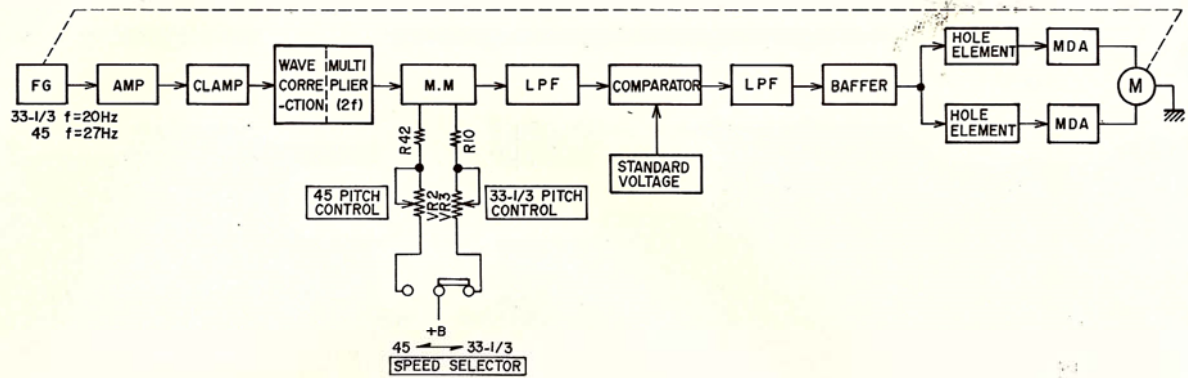

Fig. 7

2. MODEL AP-306/C

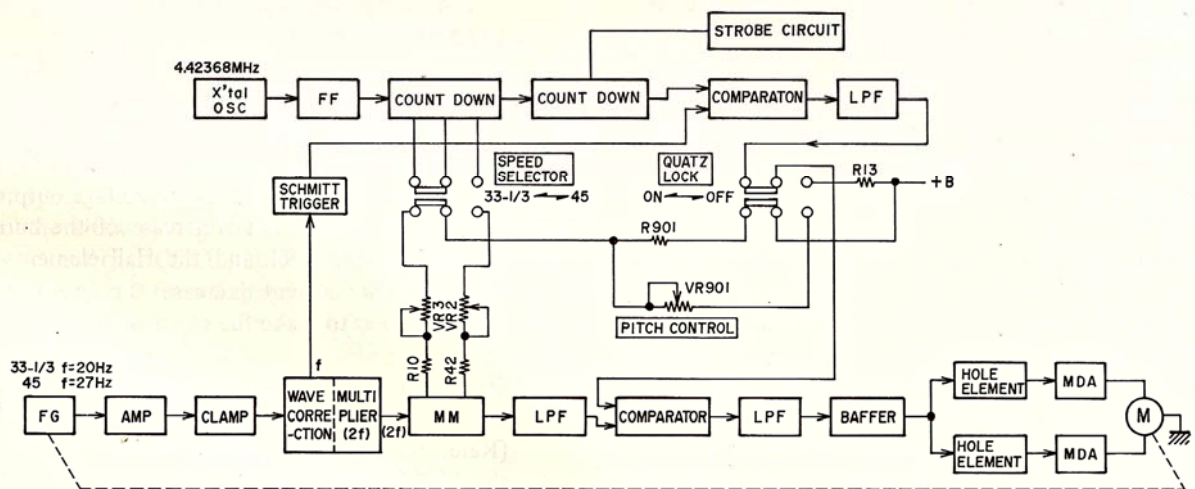

Fig. 8

VI. CIRCUIT OPERATION

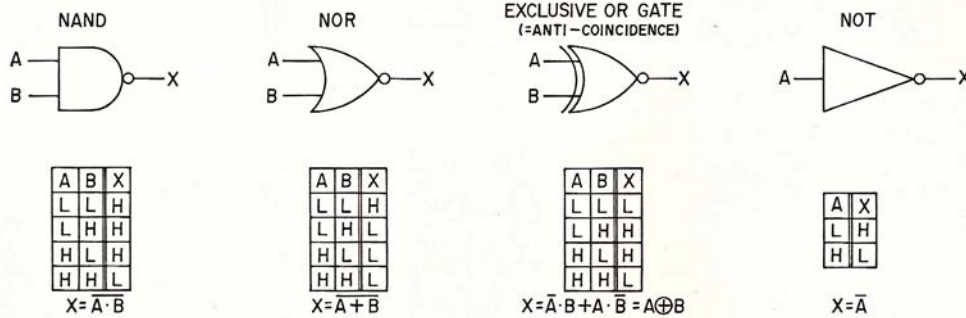

Fig. 9

1. GENERAL

The AP-206/C has a D.D (Direct Drive) P.C Board (AP-2642) that contains a FG (Frequency Generator) the signal output of which controls the motor. The AP-306/C has a PLL (Phase-Locked Loop) P.C Board (AP-3601) in addition to the electrical circuit in the AP-206/C.

The PLL circuit in the AP-306/C consists of a Quartz Lock Circuit and a Stroboscope Circuit. The stroboscope circuit flashes the neon tube NE901 in synchronism with the frequency to which the crystal oscillator frequency is accurately counted down, while the neon tube NE901 in the AP-206/C is activated by the line power to flash the Strobe markings on the turntable.

2. SERVO CIRCUIT

1) Operation when the Quartz Lock Switch SW903 is OFF

(Refer to the D.D Circuit schematic diagram of the AP-306/C.)

The motor incorporates a FG coil that produces FG signal as the motor rotates. The FG signal frequency is 20 Hz for 33-1/3 rpm and 27 Hz for 45 rpm.

The FG signal is magnified through IC1 (4~8). The magnified FG signal is clamped to positive side by R40 and VR1, and enters IC2 ①.

In IC2, the signal is waveform-shaped and frequency-doubled. The doubled signal is fed to IC3 ①, as an input to Mono Multi. The Mono Multi provides a characteristic that its stable state is inverted by an external trigger into the unstable state, where it remains for a predetermined time before returning to the original stable state. The pulse output of Mono Multi IC3 ⑩ is smoothed by C7 to DC, which is led to IC1 ② as the voltage to be compared. When the Quartz Lock Switch SW903 is off, a reference voltage is applied to IC1 ③.

The voltage at IC1 ② is compared with the reference voltage at IC1 ③, and the output appears at IC1 ①. The output at IC1 ① is passed

through the phase correction circuit, consisting of C9 through C11 and R18 through R20, to TR1. TR1 makes current flow through the Hall Elements H1 and H2, which are installed in position under the rotor magnet of the motor. The voltage developed across each Hall element is in proportion to the current flowing through the Hall Elements and the strength of the magnetic field of the rotor magnet.

The voltages output of the two Hall elements are supplied to the motor drive amplifier, consisting of IC4 (4~8), TR2 and TR3 and IC4 (1~3), TR4, and TR5, to control motor speed.

If the motor speed is made late by some cause, the FG signal frequency becomes lower. The width of the pulse output of the IC3 Mono Multi becomes wider. This increases the comparison voltage at IC1 ②, which in turn raises the voltage output of IC1 ①. The result is an increase of the current flowing through TR1 and the Hall elements H1 and H2. The current increase the motor drive amplifier so as to make the motor speed fast.

2) Operation when the Quartz Lock Switch SW903 is ON

(Refer to the PLL Circuit schematic diagram of the AP-306/C.)

The 4.42368 MHz signal generated by the crystal oscillator is delivered through TP-1 to IC2 ③. The Flip-Flop in IC2 halves the oscillation frequency of 4.42368 MHz. The frequency-halved signal is delivered as a clock pulse to IC3 ⑮, which counts it down to 1/27 (81.920 Hz) for 33-1/3 rpm or 1/20 (110.592 Hz) for 45 rpm according as set by the Speed Selector Switch SW902. The count-down signal, which appears at IC3 ⑩, is further counted down to 20 Hz for 33-1/3 rpm or 27 Hz for 45 rpm at IC4 ①. This output signal of IC4 ① enters the comparison circuit in IC5 ⑦, as a set pulse.

On the other hand, the FG signal fed through the D.D circuit to the PLL circuit is waveform-shaped by the Schmitt trigger in IC1 (10~13), and is fed

through IC1 ⑩, and R3 to IC5 ⑧ as the reset pulse. The reset pulse of 20 Hz for 33-1/3 rpm or 27 Hz for 45 rpm shaped from the FG signal is compared with the above-mentioned set pulse entering IC5 ⑦, and the output appears at IC5 ③.

The output pulse is smoothed by the low-pass filter, consisting of C9, C10, and R5 through R7, and enters IC5 ②, then the inverted output is fed from IC5 ①. The output of IC5 ① fed through R8 and SW903 to IC1 ③, in the D.D circuit as the reference voltage. In short, when the Quartz Lock Switch SW903 is off, the reference voltage is made of the +B voltage, while when it is on, the pulse made of the FG signal is compared with the pulse generated by the crystal oscillator to produce the reference voltage. The succeeding operation is similar to the one when the Quartz Lock Switch is off.

3. STROBE LIGHT CIRCUIT

(Refer to the PLL Circuit schematic diagram of the AP-306/C.)

The 4.42368 MHz signal generated by the crystal oscillator is delivered through TP-1 to IC2 ③. The Flip-Flop in IC2 halves the oscillation frequency to 2.21184 MHz. The halved signal is fed from IC2 ①, to IC3 ⑮. IC3 counts the frequency down to 1/27 for 33-1/3 rpm or 1/20 for 45 rpm.

The count-down signal is fed from IC3 ⑩, to IC4 ⑩.

IC4 further counts the signal down to 160 Hz at IC4 ⑫, 320 Hz at IC4 ⑬ and 80 Hz at IC4 ⑭ for 33-1/3 rpm or to 216 Hz, 432 Hz and 108 Hz for 45 rpm, respectively. These output signals are input to the NOR circuit of IC6 (1~5). The NOR circuit outputs from IC6 ①, 80 Hz signal for 33-1/3 rpm or 108 Hz signal for 45 rpm. The signal is fed through R10 to TR1 to turn on and off, which flashes the neon lamp NE901.

Reference: Logic Symbols and Their Truth Table

VII. MECHANICAL ADJUSTMENT

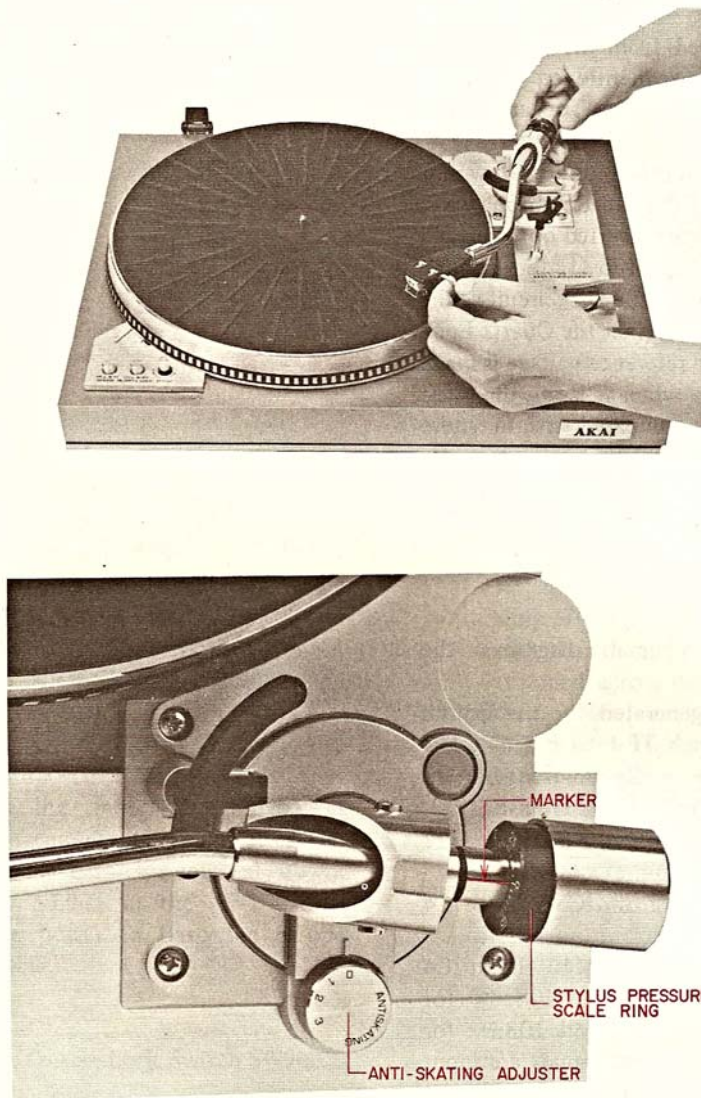

Fig. 10

1. STYLUS PRESSURE ADJUSTMENT

(Refer to Fig. 10)

- 1) Plug the power cord into a wall outlet of rated voltage.
- 2) Unlock tone arm.
- 3) Bring the tone arm over to the turntable to start the motor. Pull the Start/Cut lever toward you and release immediately.
- 4) Wait until the tone arm lift is completely lowered.
- 5) Keep the tone arm between the turntable and arm rest without touching either.
- 6) Rotate the main weight backward and forward until the tone arm is in perfect horizontal balance. (Zero balance is attained.)

CAUTION 1: Be sure that the Antiskating Adjuster is set to zero.

2: Be careful not to damage the stylus.

- 7) Without moving the main weight, turn the stylus

- pressure scale ring only to match the "0" mark with the marker on the weight shaft (See Fig. 10).
- 8) Turn the main weight counterclockwise (as viewed from the front) with the stylus pressure scale ring until the marker on the weight shaft corresponds to the desired stylus pressure on the scale.

NOTE 1: The AP-206 and AP-306 Black and Silver Panel Models do not come equipped with cartridge.

- 2: The recommended stylus pressure for the supplied stylus (AP-206C and AP-306C only) is 2 grams. However, in the case of outside interference, more pressure may be needed for stability. The range of adjustment is from 0 to 3 grams.

- 9) Set the antiskating adjuster to correspond with the stylus pressure. (Fine adjust if necessary.)

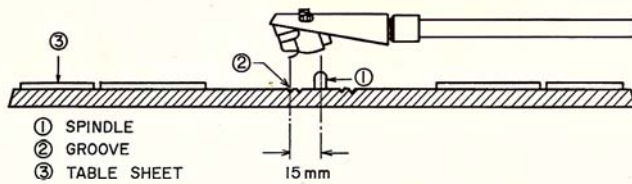
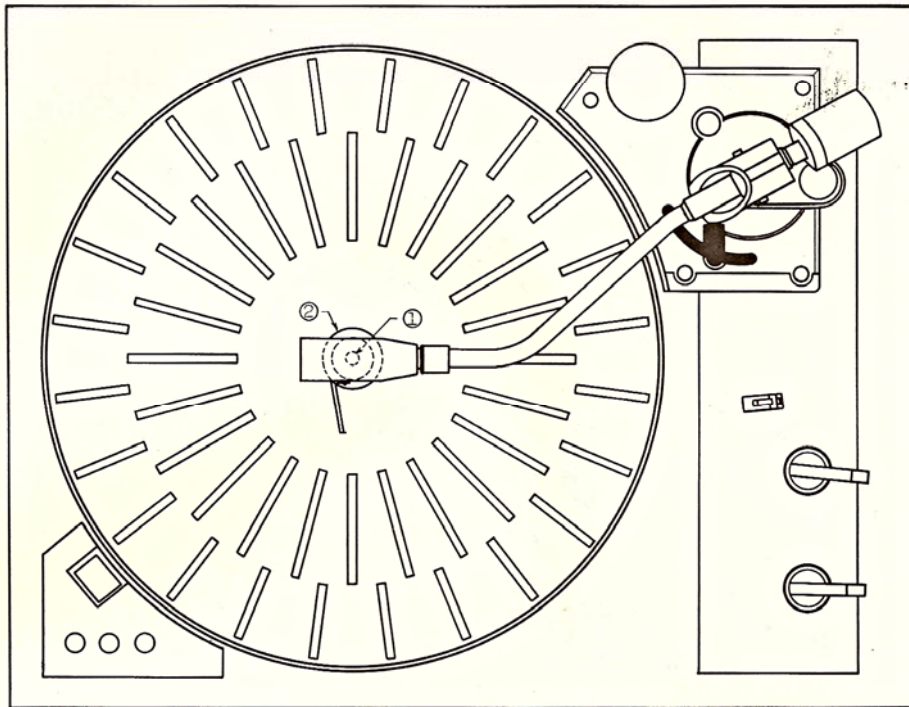

Fig. 11

2. OVER HANG ADJUSTMENT

(Refer to Fig. 11)

The distance of the stylus from the turntable shaft when the tone arm is at the turntable is called "overhang". Although the overhang is preset at the factory for this model, adjustment may be necessary when the cartridge is replaced. For your convenience, the rubber turntable mat has indicator groove at the center for easy overhang adjustment. Bring the tone arm to the center of the turntable. Adjust the cartridge position in the cartridge shell so that the stylus position is even with the outside groove ring. The cartridge position is adjustable by resetting the screws on the cartridge shell.

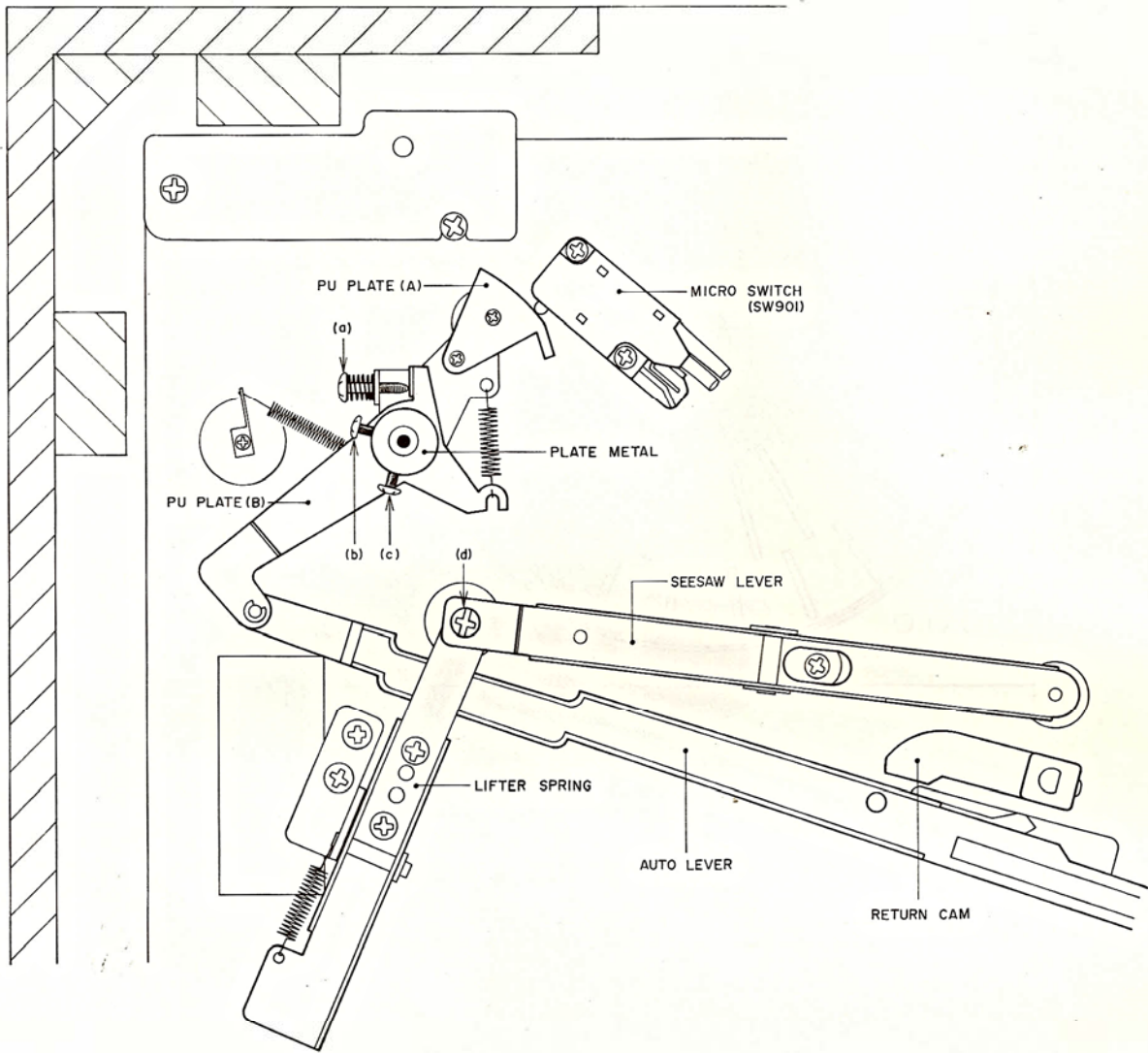

Fig. 12

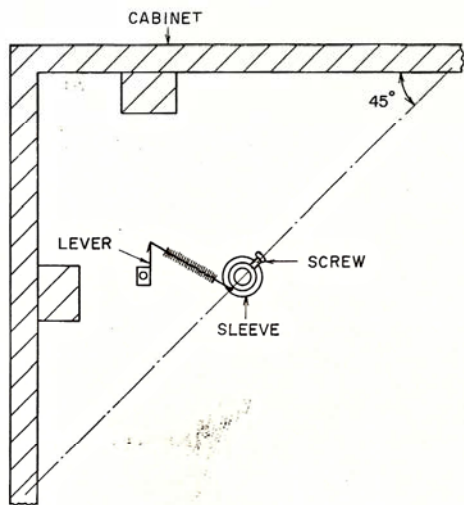

Fig. 13

3. SLEEVE POSITION ADJUSTMENT

(Refer to Fig. 13)

The sleeve position adjusts antiskating feature.

- 1) Put the tone arm in the "stop" state, or on the arm rest.
- 2) Set the sleeve, located between the PU Plate and the chassis, to approximately 45° position as shown in Fig. 13.

4. PU PLATE ADJUSTMENT (Refer to Fig. 12)

- 1) Put the tone arm in the "stop" state.
- 2) Loosen the screws (b) and (c).
- 3) Adjust the PU plate (A) so that it may actuate the microswitch to turn on or off properly.
- 4) Tighten the screws (b) and (c).
- 5) Temporarily set the screw (a) in a half screwed position.

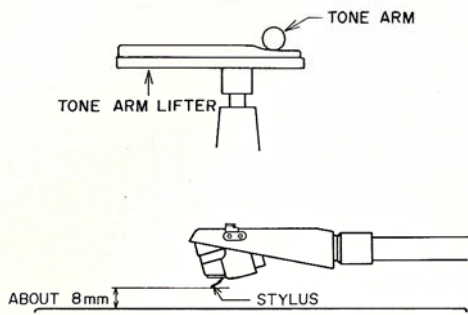

Fig. 14

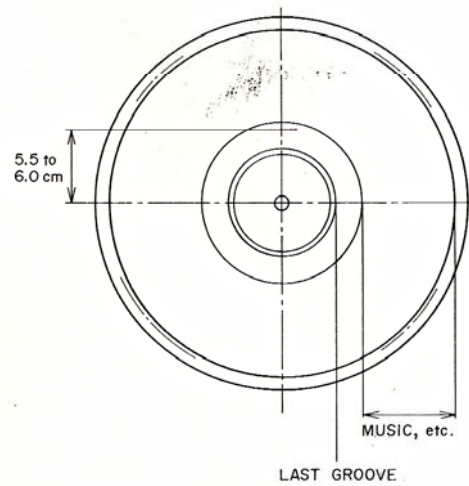

Fig. 15

5. LIFTER HEIGHT ADJUSTMENT

(Refer to Fig. 12 and Fig. 14)

- 1) Adjust the screw (d) (see Fig. 12) until the tone arm fits to the tone arm lifter as shown in Fig. 14.
- 2) Check to insure that the height of the stylus is around 8 mm above the disk surface when the tone arm is supported on the tone arm lifter.
- 3) Make certain that silicon oil remains on the tip of the lifter spring. If not apply it to prevent mechanical noise.

6. AUTOMATIC RETURN POSITION

ADJUSTMENT (Refer to Fig. 12 and Fig. 15)

- 1) Adjust the screw (d) (see Fig. 12) until the tone arm returns automatically at a desired point.

NOTE: The automatic return range is around 5.5 to 6.0 cm from the center of a 30 cm disk (see Fig. 15).

Turning the screw clockwise shifts the return point inward, and turning counter-clockwise shifts it outward.

- 2) After adjustment, play a 17 cm and 30 cm disks bak to check that the tone arm returns at a correct point.

VIII. ELECTRICAL ADJUSTMENT

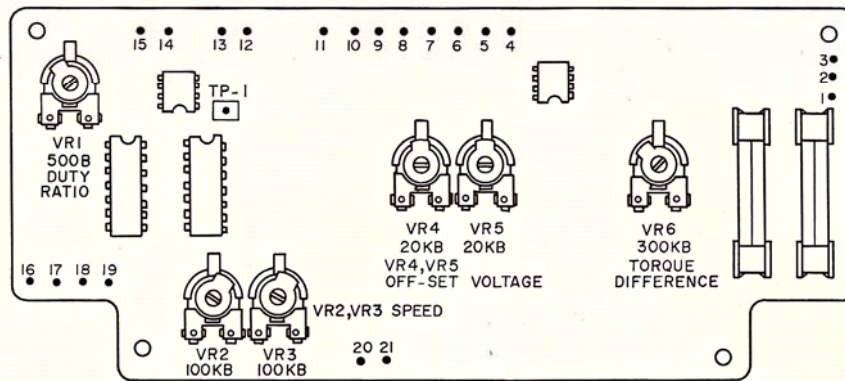

Fig. 16 Direct Drive P.C Board Adjust Points

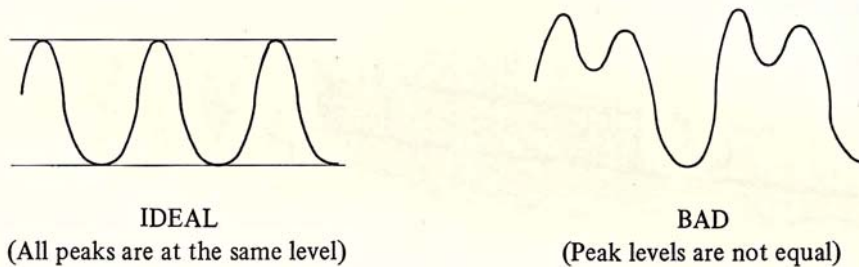

Fig. 17

1. DIRECT DRIVE P.C BOARD

ADJUSTMENT

1) Off-set Voltage Adjustment (VR4, VR5)

- Disconnect the motor connection wire. (Open pins 4 through 11 and 14, 15 then leaving the other pins connected.)
- Connect a DC voltmeter (digital voltmeter) between pins 6 and 8 (ground).
- Short the circuit of pins 9 and 10.
- Power "ON" (move the tone arm)
- Adjust VR4 until the output at pin 6 is $0V \pm 10$ mV for the AP-206/C and 80 ± 10 mV for AP-306/C.
- Power "off" and open the circuit of pins 9 and 10.
- Connect a DC voltmeter (digital voltmeter) between pins 7 and 8 (ground).
- Short the circuit of pins 4 and 5.
- Power "ON" (move the tone arm).
- Adjust the VR5 until the output at pin 7 is $0V \pm 10$ mV for AP-206/C and 80 mV ± 10 mV for AP-306/C.

* After Off-set Voltage Adjustment, make the connection as normal position.

2) DUBY Ratio (1:1) Adjustment (VR1)

- Connect an oscilloscope to TP-1.
- Set the SPEED selector to the "33-1/3" position.
For the AP-306/C, release the Quartz Lock button to the OFF position.
- Move the tone arm to rotate the motor.
- Adjust VR1 until the oscilloscope shows a waveform or as Fig. 17.

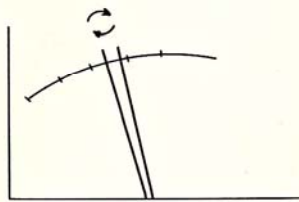

Fig. 18

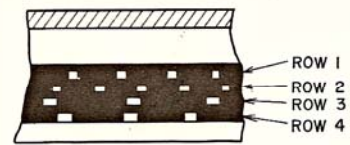

Fig. 19

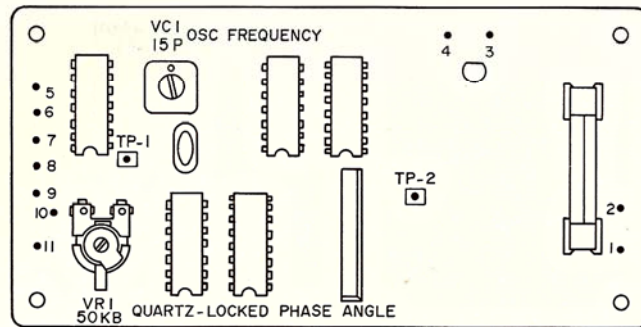

Fig. 20 PLL P.C Board Adjust Points

3) Torque Difference Adjustment (VR6)

- Connect a dual-channel AC voltmeter to pins 6, 7 and 8 (common ground).
- Set the Speed selector to the "33-1/3" position. For the AP-306/C, release the Quartz Lock button to the "OFF" position.
- Move the tone arm to rotate the motor.
- Adjust VR6 until the outputs at pins 6 and 7 are of the same level.

NOTE: As the output frequency is as low as a few Hz, the voltmeter needles will vibrate minutely. In the state of correct adjustment, the two needles will seem intertwining as shown below.

CAUTION: In the adjustment, only make both voltages equal as these varies with the motor rpm.

4) Speed Adjustment (VR2, VR3)

- Set the Speed selector to the "33-1/3" position. (For the AP-306/C, release the Quartz Lock button to the "OFF" position.)
- Set the Pitch control to the center.
- Move the tone arm to rotate the motor.
- For the AP-206/C, adjust VR3 until the Strobe markings on the first line for 50 Hz power or the second line for 60 Hz power is seen standing still. For the AP-306/C, also adjust VR3 until the single Strobe markings is seen standing still.

- In turn, reset the Speed selector to the "45" position.

- For the AP-206/C, similarly adjust VR2 until the Strobe markings on the third line for 50 Hz power or the fourth line for 60 Hz power is seen standing still.

NOTE: It is important that the Strobe markings should not rotate in the reverse direction of the motor, or rightward as in the above line drawing.

2. PLL P.C BOARD ADJUSTMENT

(Model AP-306/C only)

1) Adjusting the Oscillation Frequency (VC1)

- Connect a frequency counter to TP-1 and pin 5 (ground).
- Set the Speed selector to the "33-1/3" position.
- Move the tone arm to turn power on.
- Adjust VC1 until the frequency counter reads $4,423,680 \pm 10$ Hz.

CAUTION: For turning VC1, use a RF adjusting screwdriver.

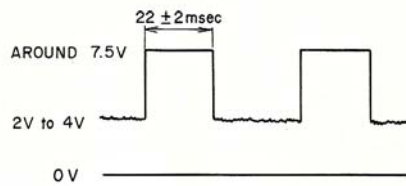

Fig. 21



Fig. 22

2) Adjusting the Quartz-Locked Phase Angle (VR1)

- a) Connect an oscilloscope to TP-2 and pin 5 (ground).
- b) Release the Speed selector to the "33-1/3" position.
- c) Depress the Quartz Lock button in ON.
- d) Move the tone arm to turn power on.
- e) Adjust VR1 until the width of the upward pulse above 2 to 4V is 22 ± 2 msec when the Strobe markings is seen standing still, as Fig. 21. (oscilloscope-DC Mode)

CAUTION: The upward pulse around +7.5V shown above may change to downward pulse (0V) below 2 to 4V with VR1 turned as Fig. 22. Be careful not to measure the width of the downward pulse, It is checked in a simple way that the upward pulse will change to downward pulse by loading on the platter by hand.

IX. CLASSIFICATION OF VARIOUS P.C BOARDS

1. P.C BOARD TITLE AND IDENTIFICATION NUMBER

P.C Board Title	P.C Board Number	Utilizing Model
Power Supply P.C Board	AP-2641	AP-206/C, AP-306/C
D.D P.C Board	AP-2642	AP-206/C, AP-306/C
Neon Lamp P.C Board	AP-2643	AP-206/C, AP-306/C
Relay P.C Board	AP-2652	AP-206/C, AP-306/C
PLL P.C Board	AP-3601	AP-306/C

2. COMPOSITION OF VARIOUS P.C BOARDS

1) D.D. P.C BOARD AP-2642

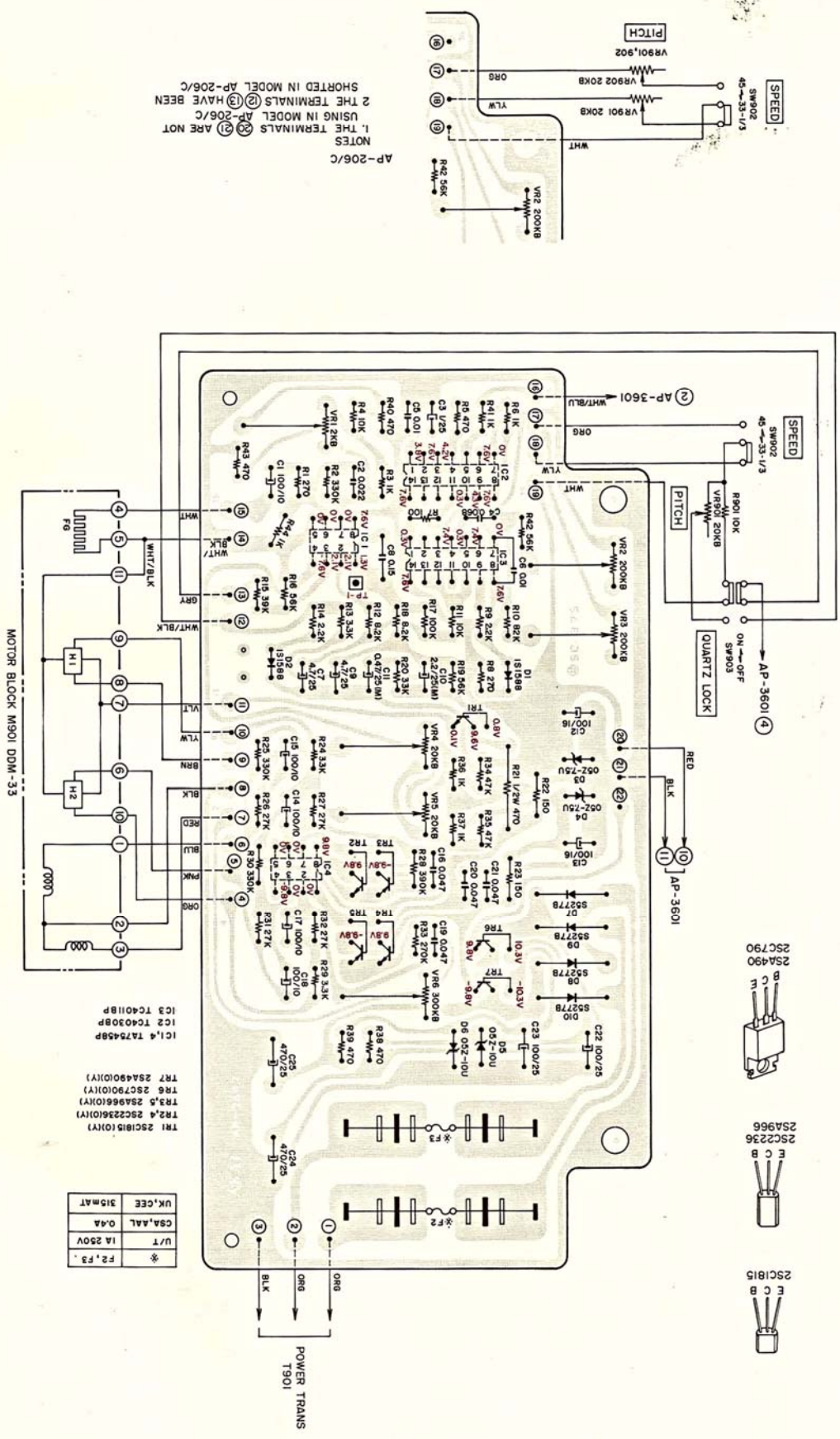

U/K.CEE	315MAT
GSA, AAL	0.4A
U/T	1A 250V
* F2, F3	

- TR1 25C1815(O1Y)
- TR2, 4 25C2236(O1Y)
- TR3, 5 25A966(O1Y)
- TR6 25C790(O1Y)
- TR7 25A901(O1Y)
- IC1, 4 TA75458P
- IC2 TC4030BP
- IC3 TC4011BP

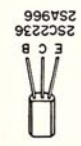
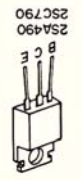

NOTES
 1. THE TERMINALS (2) ARE NOT USING IN MODEL AP-206/C
 2. THE TERMINALS (3) HAVE BEEN SHORTED IN MODEL AP-206/C

AP-206/C

MOTOR BLOCK M901 DDM-33

POWER TRANS
 T901

2) PLL P.C BOARD AP-3601 (Model AP-306/C only)

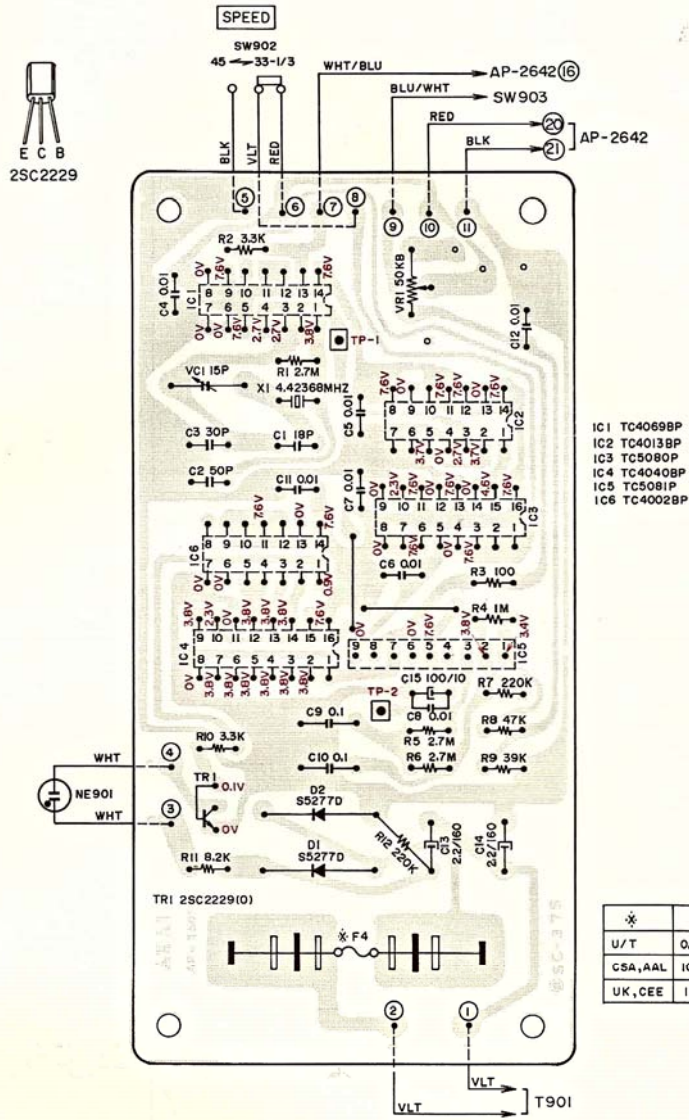

3) POWER SUPPLY P.C BOARD AP-2641 (U/T)

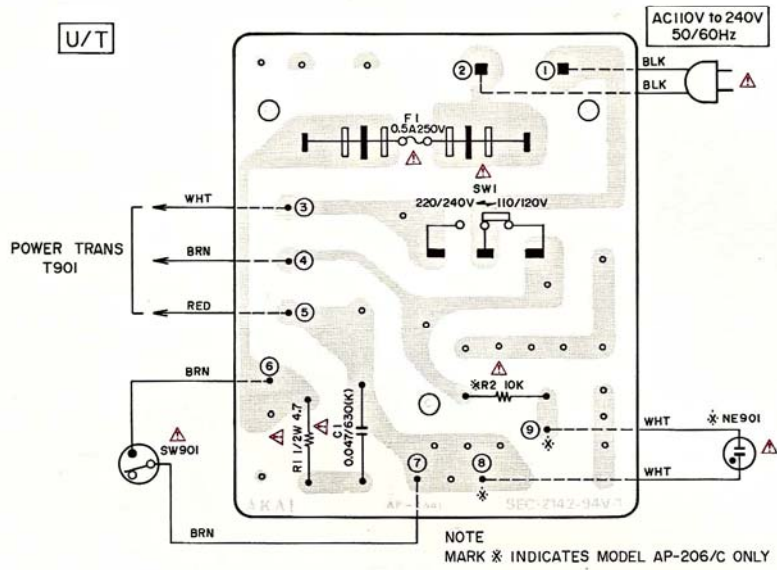

WARNING: Δ INDICATES SAFETY CRITICAL COMPONENTS. FOR CONTINUED SAFETY, REPLACE SAFETY CRITICAL COMPONENTS ONLY WITH MANUFACTURER'S RECOMMENDED PARTS.
AVERTISSEMENT: Δ IL INDIQUE LES COMPOSANTS CRITIQUES DE SÛRETÉ. POUR MAINTENIR LE Degré DE SÛRETÉ DE L'APPAREIL, NE REMPLACER LES COMPOSANTS DONT LE FONCTIONNEMENT EST CRITIQUE POUR LA SÛRETÉ QUE PAR DES PIÈCES RECOMMANDÉES PAR LE FABRICANT.

4) POWER SUPPLY P.C BOARD AP-2641 (AAL, CSA)

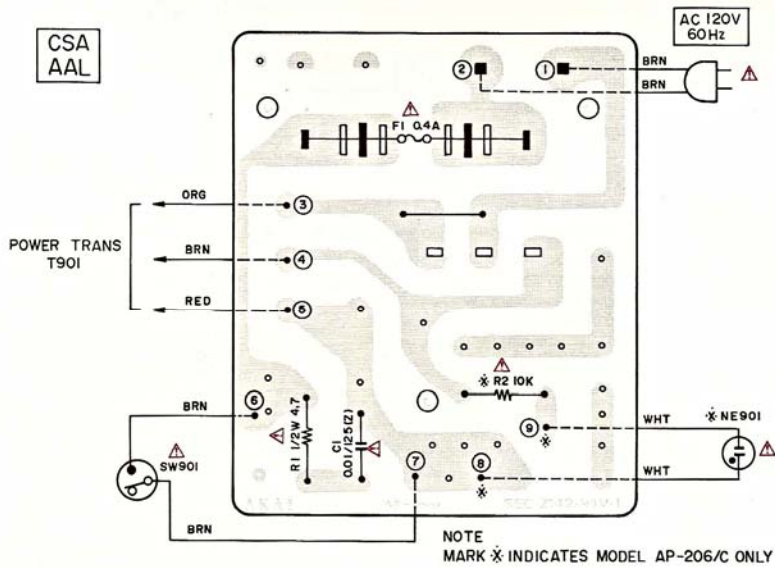

WARNING: Δ INDICATES SAFETY CRITICAL COMPONENTS. FOR CONTINUED SAFETY, REPLACE SAFETY CRITICAL COMPONENTS ONLY WITH MANUFACTURER'S RECOMMENDED PARTS.
AVERTISSEMENT: Δ IL INDIQUE LES COMPOSANTS CRITIQUES DE SÛRETÉ. POUR MAINTENIR LE Degré DE SÛRETÉ DE L'APPAREIL, NE REMPLACER LES COMPOSANTS DONT LE FONCTIONNEMENT EST CRITIQUE POUR LA SÛRETÉ QUE PAR DES PIÈCES RECOMMANDÉES PAR LE FABRICANT.

5) POWER SUPPLY P.C BOARD AP-2641 (UK, CEE)

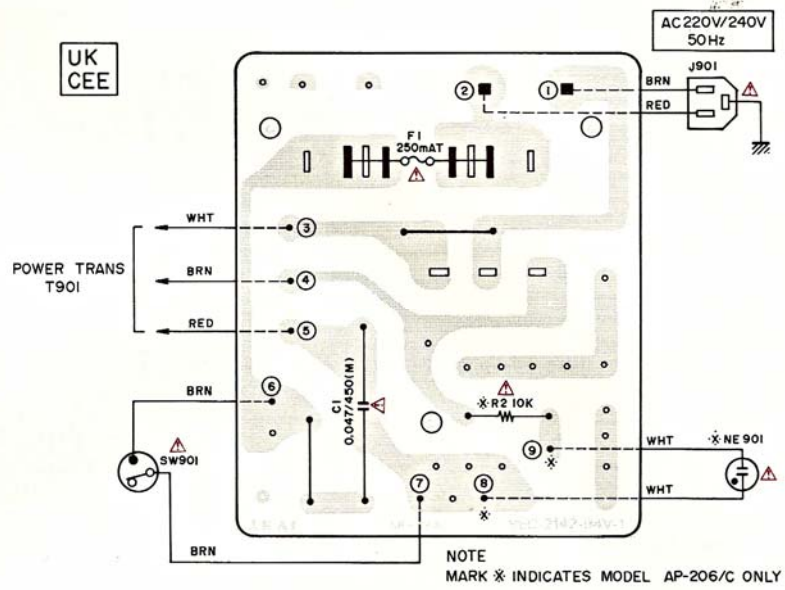

WARNING: Δ INDICATES SAFETY CRITICAL COMPONENTS. FOR CONTINUED SAFETY, REPLACE SAFETY CRITICAL COMPONENTS ONLY WITH MANUFACTURER'S RECOMMENDED PARTS

AVERTISSEMENT: Δ IL INDIQUE LES COMPOSANTS CRITIQUES DE SURETE. POUR MAINTENIR LE DEGRE DE SECURITE DE L'APPAREIL, NE REMPLACEZ LES COMPOSANTS DONT LE FONCTIONNEMENT EST CRITIQUE POUR LA SECURITE QUE PAR DES PIECES RECOMMANDEES PAR LE FABRICANT

MEMO

MEMO

MEMO

MEMO

AP-206
AP-306

AKAI ELECTRIC CO., LTD.

P.O. BOX 21, Tokyo Airport, Japan
(1-2-14, 2-chome, Higashi-Kojiya, Ohta-ku,
Tokyo, Japan) TELEPHONE: TOKYO (742) 5111

CABLE: HIFIAKAI TOKYO TELEX: J26261

Printed No. 1561842 1 1ED Printed Date October 13, 1978
Printed in Japan