

AKAI SERVICE MANUAL

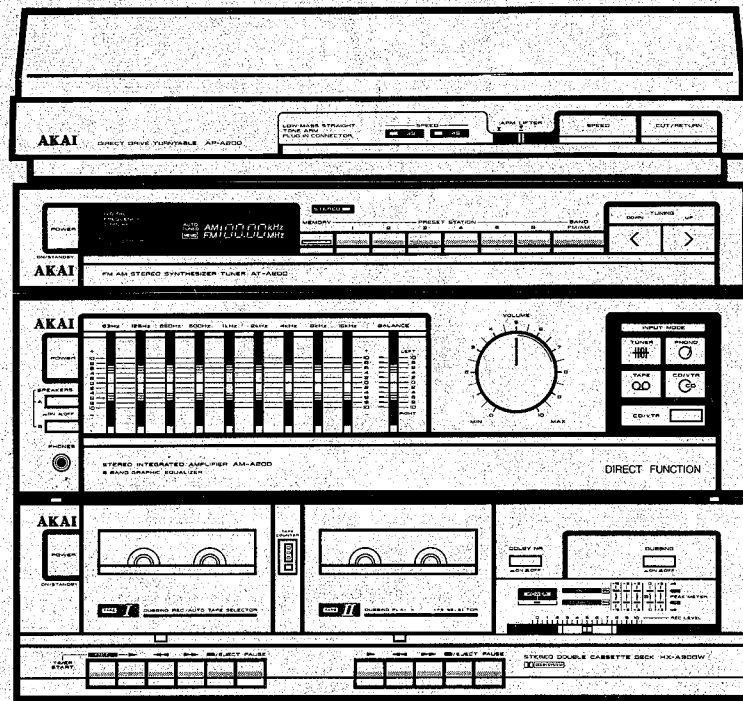

PRO-A200D/A200WD

COMPATIBLE TURNTABLE

MODEL AP-A100/C, A200/C

TUNER

MODEL AT-A200/L

AMPLIFIER

MODEL AM-A200

CASSETTE DECKS

MODEL HX-A200, A300W



PRO-A200D/A200WD

MODEL AP-A100/C, AP-A200/C, AT-A200/L,
AM-A200, HX-A200, HX-A300W

SECTION 1	MODEL AP-A100/C SERVICE MANUAL	5
SECTION 2	MODEL AP-A200/C SERVICE MANUAL	11
SECTION 3	MODEL AT-A200/L SERVICE MANUAL	17
SECTION 4	MODEL AM-A200 SERVICE MANUAL	23
SECTION 5	MODEL HX-A200 SERVICE MANUAL	27
SECTION 6	MODEL HX-A300W SERVICE MANUAL	35
SECTION 7	PARTS LIST (AP-A100/C, AP-A200/C, AT-A200/L, AM-A200, HX-A200, HX-A300W)	43

SAFETY INSTRUCTIONS

SAFETY CHECK AFTER SERVICING

Confirm the specified insulation resistance between power cord plug prongs and externally exposed parts of the set is greater than 10 Mohms, but for equipment with external antenna terminals (tuner, receiver, etc.) and is intended for **C** or **A**, specified insulation resistance should be more than 2.2 Mohms (ground terminals, microphone jacks, headphone jacks, line-in-out jacks etc.)

PRECAUTIONS DURING SERVICING

1. Parts identified by the **△** symbol parts are critical for safety.
Replace only with parts number specified.
2. In addition to safety, other parts and assemblies are specified for conformance with such regulations as those applying to spurious radiation. These must also be replaced only with specified replacements.
Examples: RF converters, tuner units, antenna selector switches, RF cables, noise blocking capacitors, noise blocking filters, etc.
3. Use specified internal wiring. Note especially:
 - 1) Wires covered with PVC tubing
 - 2) Double insulated wires
 - 3) High voltage leads
4. Use specified insulating materials for hazardous live parts. Note especially:
 - 1) Insulation Tape
 - 2) PVC tubing
 - 3) Spacers (Insulating Barriers)
 - 4) Insulation sheets for transistors
 - 5) Plastic screws for fixing microswitch (especially in turntable)
5. When replacing AC primary side components (transformers, power cords, noise blocking capacitors, etc.), wrap ends of wires securely about the terminals before soldering.

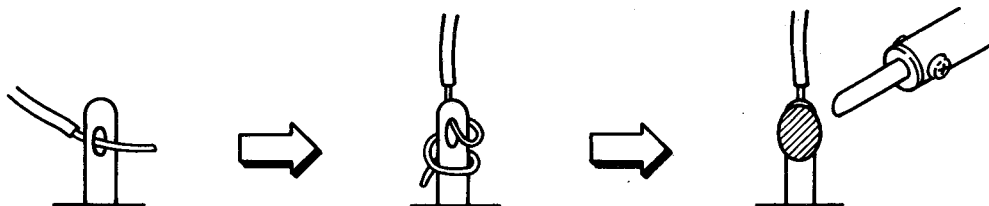

6. Observe that wires do not contact heat producing parts (heatsinks, oxide metal film resistors, fusible resistors, etc.).
7. Check that replaced wires do not contact sharp edged or pointed parts.
8. Also check areas surrounding repaired locations.
9. Use care that foreign objects (screws, solder droplets, etc.) do not remain inside the set.

VOLTAGE CONVERSION

Models for Canada, Europe, UK and Australia are not equipped with this facility. Each machine is preset at the factory according to destination, but some machines can be set to 110V, 120V, 220V or 240V as required. If your machine's voltage can be converted: Turn the voltage selector, located on the AM-A200 Amplifier's back panel, with a screwdriver until the correct voltage is indicated.

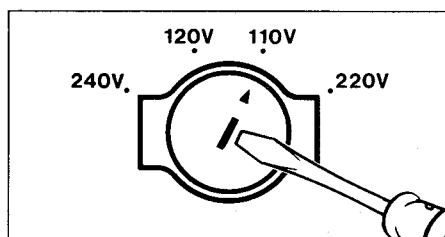

INTRODUCING THE AKAI PRO-200 SERIES COMPONENTS

The PRO-A200 components are microcomputer controlled for easy (Direct Function) operation and convenient recording. The direct connection plugs on the Tuner, Amplifier, and Cassette deck sections make connection simple. The PRO-A200 components will provide you with years of high quality Hi-Fi, for your listening pleasure.

1. PRO-A200 SERIES LINE-UP

	PRO-A200	PRO-A200D	PRO-A200W	PRO-A200WD
Turntable	AP-A100/C	AP-A200/C	AP-A100/C	AP-A200/C
Tuner	AT-A200/L			
Amplifier	AM-A200			
Cassette Deck	HX-A200		HX-A300W	

OPTIONAL

Timer	DT-A2
Audio Rack	RV-A100

2. FEATURES

1) AP-A100/C

- Semi automatic player system
Set the record speed, then use the damped cue control arm to lift and lower the tone arm. The Akai AP-A100 will automatically locate the end of each record and return to the tone arm rest when the selection is finished. If you want to lift the tone arm from one section and start another, the tone arm Cue Control Damper eliminates the possibility of accidental scratches to your records.
- Low resonant cabinet which helps prevent distortion
- Sensitive straight tone arm
-  type plug in cartridge (AP-A100C only)
- DIRECT FUNCTION control makes playback and recording operations simple, when combined with the Akai AC-A100/L.

2) AP-A200/C

- Low mass straight tone arm
- Low resonant cabinet which helps prevent distortion
- Semi automatic Direct Drive player system
Set the record speed, then use the damped cue control arm to lift and lower the tone arm. The Akai AP-A200 will automatically locate the end of each record and return to the tone arm rest when the selection is finished. If you want to lift the tone arm from one section and start another, the tone arm Cue Control Damper eliminates the possibility of accidental scratches to your records.
-  type plug in cartridge (AP-A200C only)
- DIRECT FUNCTION control makes playback and recording operations simple, when combined with the Akai PRO-A200.

3) AT-A200/L

- Microcomputer controlled Tuner for accurate tuning.
- Up to 12 stations can be memorized (6 AM band, and 6 FM band)
- FL digital display panel

4) AM-A200

- Features of the AM-A200 Stereo Integrated Amplifier
- Nine band graphic equalizer for adjusting the sound to suit your taste, can be used during playback and recording operations.
 - DIRECT FUNCTION control automatically activates the tuner, tape deck and Phono.
 - BALANCE control and large VOLUME control dial
 - CD/VTR input mode selector button for use when you want to playback another audio component connected to the rear panel CD/VTR jacks

5) HX-A200

- Direct Function recording with the tuner, phono, or other connected audio component
- Automatic Recording Level Control (ALC) for convenient recording.
- DOLBY NR (B) switch for use of the Dolby Noise Reduction System
- Full auto stop, the tape will automatically stop during all tape functions, when the end of the tape is reached.
- One touch recording button for easy recording
- Timer (optional) can be used for Timed Playback or Absentee Recording purposes.

6) HX-A300W

- Double cassette deck for convenient tape to tape dubbing.
- Direct Function recording with the tuner, phono, or other connected audio component.
- Auto Tape Selector for correct setting of the bias and equalization for NORMAL and CrO₂(Chrome) tapes.
- DOLBY NR (B) switch for use of the Dolby Noise Reduction System
- Full auto stop, the tape will automatically stop during all tape functions, when the end of the tape is reached.
- One touch recording button for easy recording
- Timer (optional) can be used for Timed Playback or Absentee Recording purposes.

3. THE DIRECT CONNECTION PLUGS

The PRO-A200 series Amplifier AM-A200, Tuner AT-A200 and Cassette Deck HX-A200 or HX-A300W feature the convenient Direct Connection Plugs.

The Direct Connection Plugs of the PRO-A200 series make assembly of your components quick and easy.

1. Raise the direct connection plug located on the top panel of the AM-A200 Amplifier. Once in the vertical position, push it down gently, and it will lock into position.
 2. Set the AT-A200 Tuner on top of the AM-A200 Amplifier so that the connection plug is inserted into the socket on the bottom of the AT-A200.
- Follow the same instructions for connection of your Akai compatible HX-A200 or HX-A300W Stereo Cassette Deck.

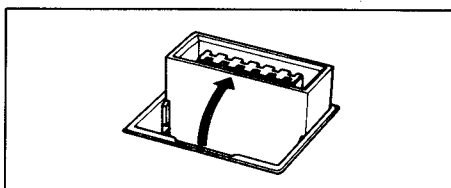

4. PLACEMENT OF THE PRO-A200

COMPONENTS

Connect components only in the order illustrated. If the components are not properly connected, the DIRECT FUNCTION control cannot function.

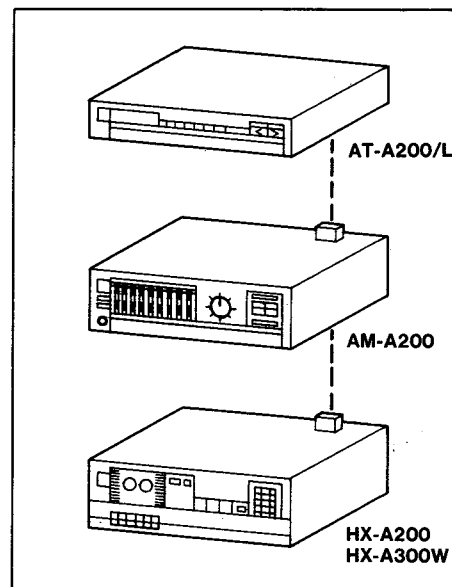

5. THE DIRECT FUNCTION CONTROL

The DIRECT FUNCTION control automatically activates the PRO-A200 series tuner, tape deck, and phono without having to use a source switch of any kind.

When you turn ON the POWER switch of the AM-A200, the microcomputer automatically selects TUNER and the last station which was tuned in on your AT-A200's AM or FM band will be turned in.

- To activate the tape deck, for example, just press the Play (▶) button and the source will switch to tape playback.
- The Turntable functions when the tone arm is lifted.
- To operate equipment which is connected to the rear panel CD/VTR jacks, depress the CD/VTR switch to ON (⬇), then press that component's Play (▶) button.



SECTION 1

SERVICE MANUAL

MODEL AP-A100/C

TABLE OF CONTENTS

I. SPECIFICATIONS	6
II. DISMANTLING OF UNIT	6
III. CONTROLS	7
IV. PRINCIPAL PARTS LOCATION	7
V. REPLACEMENT OF CARTRIDGE AND TONE ARM ASSEMBLY	8
1. HOW TO CHANGE OR INSTALL THE CARTRIDGE (Refer to Fig. 5-1)	8
2. HOW TO REPLACE THE TONE ARM ASSEMBLY (Refer to Fig. 5-2 to 5-3)	8
VI. MECHANICAL ADJUSTMENT	9
1. TONE ARM LIFTER HEIGHT ADJUSTMENT (Refer to Fig. 6-1, 6-2)	9
2. AUTO-RETURN ADJUSTMENT (Refer to Fig. 6-3)	9
VII. ELECTRICAL ADJUSTMENT	10
1. SPEED ADJUSTMENT	10
VIII. PC BOARD TITLES AND IDENTIFICATION NUMBERS	10

For basic adjustments, measuring methods, and operating principles, refer to GENERAL TECHNICAL MANUAL.

I. SPECIFICATIONS

TURNTABLE (PLATTER)	Aluminum alloy diecast
DRIVE SYSTEM	Direct drive
MOTOR	FG servo DC motor
SPEED	33-1/3 & 45rpm
WOW & FLUTTER	0.045% (WRMS)
RUMBLE	70dB (DIN-B)
STONE ARM	Static balanced type
EFFECTIVE ARM LENGTH	220mm
STYLUS PRESSURE ADJUSTMENT RANGE	1.25g (fixed)
APPLICABLE CARTRIDGE WEIGHT	5.9g
ARM LIFTER	Oil damped
OVER HANG	17.5mm
CARTRIDGE (AP-A100/C only)	VM type (PC-35/ ) plug-in type
OUTPUT VOLTAGE	2.5mV
CHANNEL SEPARATION	More than 20dB
OPTIMAL STYLUS PRESSURE	1.25g
DIMENSIONS	440(W) × 99(H) × 347(D)mm (17.3 × 3.9 × 13.7 inches)
WEIGHT	3.2kg (7.1 lbs)

* For improvement purposes, specifications and design are subject to change without notice.

II. DISMANTLING OF UNIT

In case of trouble, etc. necessitating dismantling, please dismantle in the order shown in the photographs. Reassemble in reverse order.

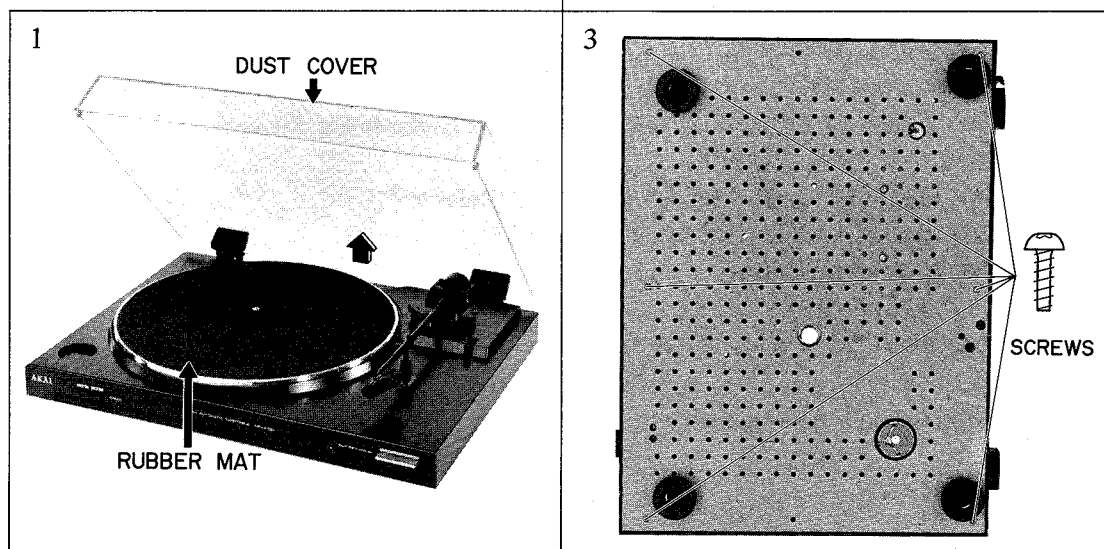

III. CONTROLS

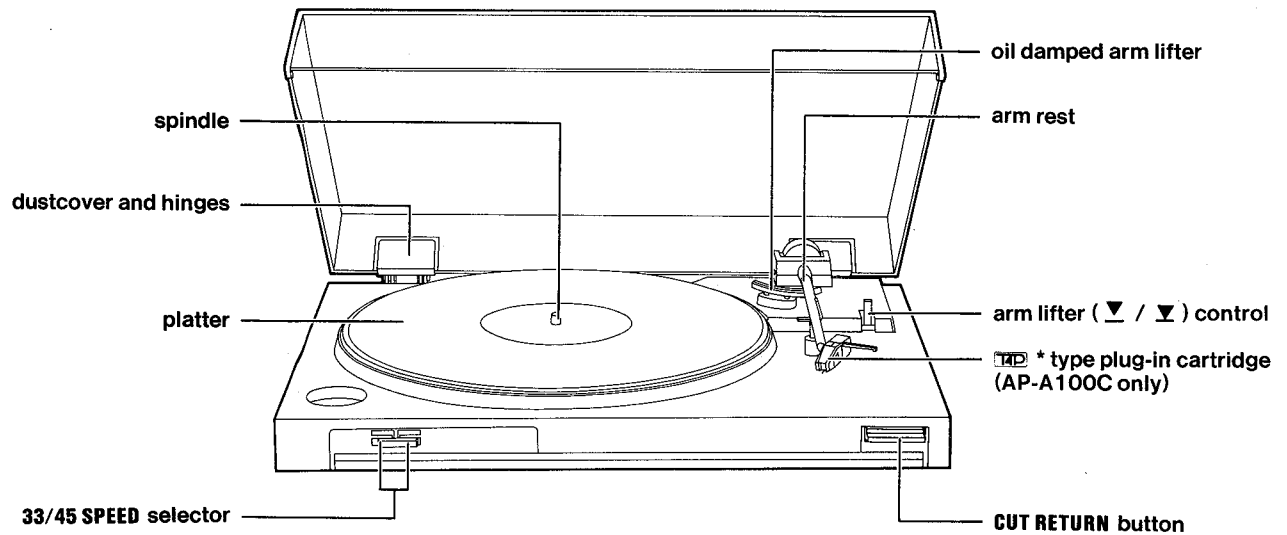

Fig. 3-1 Controls

IV. PRINCIPAL PARTS LOCATION

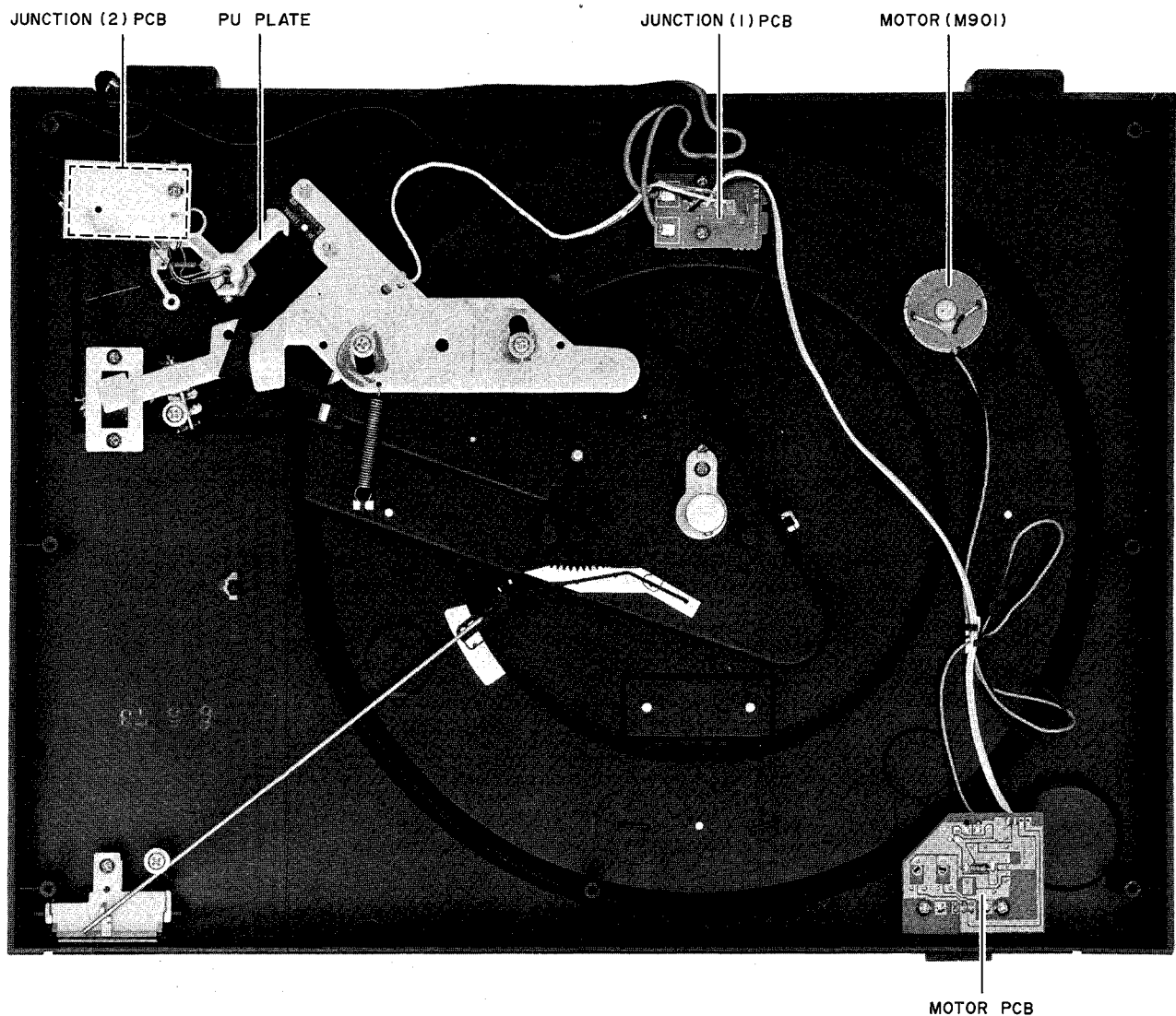

Fig. 4-1

V. REPLACEMENT OF CARTRIDGE AND TONE ARM ASSEMBLY

5-1. HOW TO CHANGE OR INSTALL THE CARTRIDGE (Refer to Fig. 5-1)

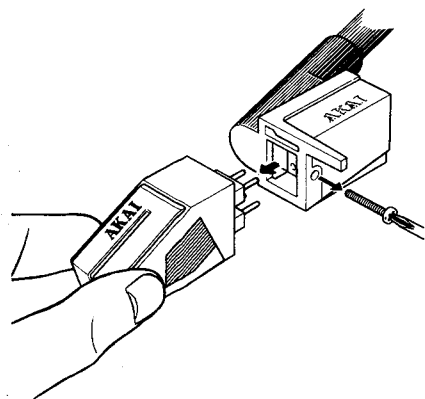



Fig. 5-1

With the tone arm on the tone arm rest and clamped, remove the screw on the side of the tone arm (directly behind the cartridge) by using a screwdriver. After removing the screw, grasp the cartridge firmly and pull it forward, away from the tone arm, until it is free. Replace the new cartridge by reversing the above operation.

In order to enjoy the full capability of the Akai AP-A100 please note the following when changing the cartridge.

- * Replace the cartridge with one which has the same output voltage (2.5mV/1kHz, 5cm/sec peak).
- *  is the standard mark for plug-in connectors. Connectors with this mark are compatible with each other. The Akai AP-A100 is equipped with a high quality VM cartridge, but any cartridge with the  mark can be used.
- * Let's protect the records.
Do not touch the grooves when handling the record.
Dirty grooves will produce distortions.
Store records standing in a well ventilated place, relatively free of dust.
- * Don't interrupt any movement.
Do not touch the tone arm or the platter and do not turn off the power under the following conditions:
 - * During record playback
 - * When the tone arm is moving automatically.
 - * When the platter is turning.
- * Be sure.
The ARM LIFTER is in the down (▼) position before attempting to clamp the tone arm to the tone arm rest.

5-2. HOW TO REPLACE THE TONE ARM ASSEMBLY (Refer to Fig. 5-2 to 5-3)

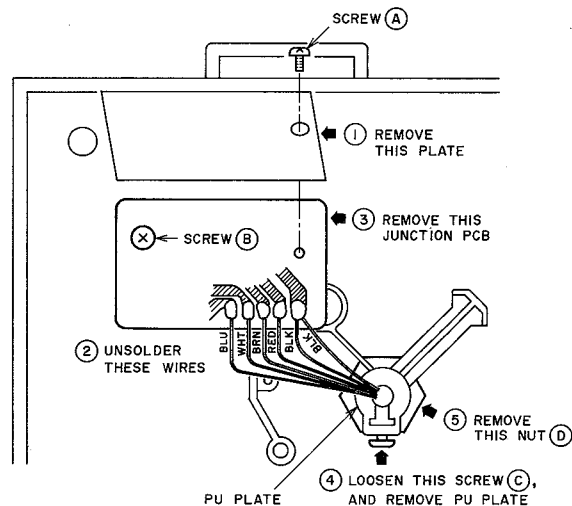

Fig. 5-2

- 1) Unscrew (A) and remove the shield plate.
- 2) Remove the wires from Tone Arm Assembly.
- 3) Unscrew (B) and remove the JUNCTION (2) PCB.
- 4) Loosen screw (C) and remove the PU lever.
- 5) Unscrew the Nut (D) and Remove the Tone Arm Assembly.
- 6) Install the New Tone Arm Assembly and do the reverse way.

After replaced the Tone Arm, PU plate position Adjustment is necessary as follow.

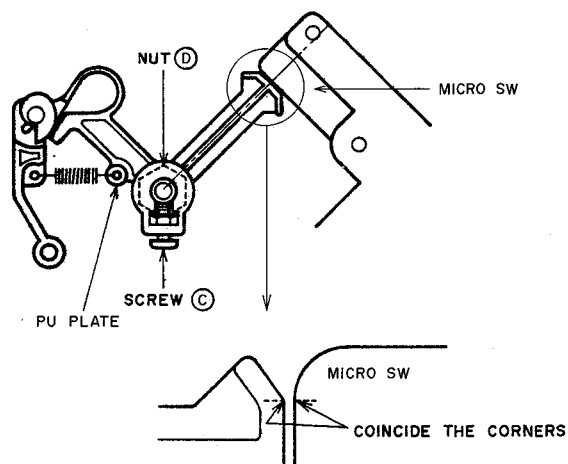

Fig. 5-3

- 1) Lock the Tone Arm on the TONE ARM REST.
- 2) Loosen the Screw (C), and Confirm that the PU PLATE is installed all the way into the Nut (D).
- 3) May loosen the screw (C) a little and turn PU PLATE so that the corner of those PU PLATE and Micro SW are coincide as shown Fig. 5-3.
- 4) Tighten screw (C).
- 5) Next excute an AUTO RETURN operation and confirm that the AUTO RETURN position is proper. Do the fine adjustment in item 6-2 AUTO-RETURN ADJUSTMENT if necessary.
- 6) Paint lock the screw (C) after the adjustment.

VI. MECHANICAL ADJUSTMENT

6-1. TONE ARM LIFTER HEIGHT ADJUSTMENT (Refer to Fig. 6-1, 6-2)

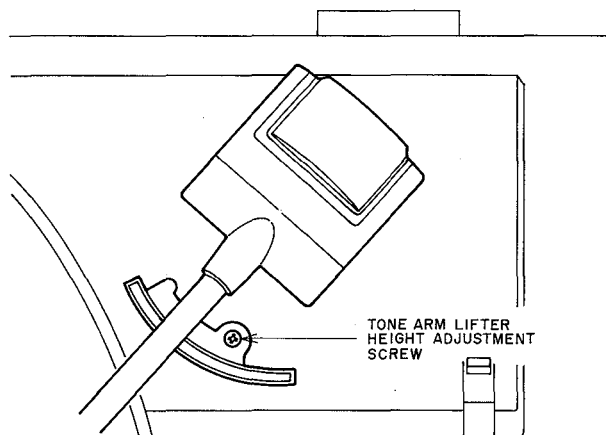

Fig. 6-1

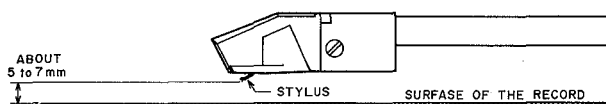

Fig. 6-2

With the Tone Arm in the up-position, the stylus should be about 6mm above the surface of the record. If it is not, adjust the height by adjusting the TONE ARM HEIGHT ADJUSTMENT SCREW.

Clockwise: Down
Counterclockwise: Up

6-2. AUTO-RETURN ADJUSTMENT (Refer to Fig. 6-3)

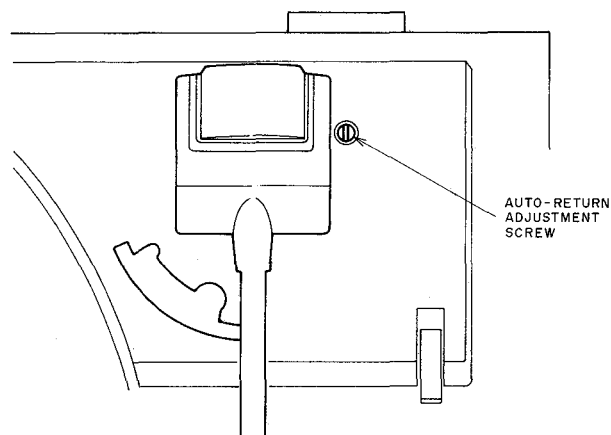

Fig. 6-3

If the Tone Arm does not return automatically to the TONE ARM REST at the end of record.

Adjust auto-return Adjustment screw as follow.

- * If the tone arm return before the end of the record
Turn the Auto-Return Adjustment Screw Clockwise.
- * If the tone arm does not return at the end of record
Turn the Auto-Return Adjustment Screw Counterclockwise.

CAUTION:

Do not turn the Auto-Return Adjustment screw too much.

VII. ELECTRICAL ADJUSTMENT

7-1. SPEED ADJUSTMENT

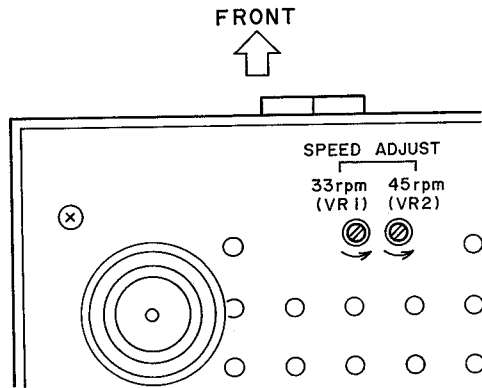

Fig. 7-1 Speed Adjustment Points

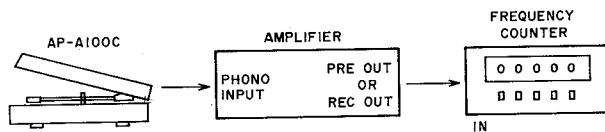

Fig. 7-2 Instruments Connection

- 1) Connect a Amplifier and Frequency counter as shown Fig. 6-2.
- 2) Set the Speed Selector to 33-1/3rpm.
- 3) Play back the Test Record (1000Hz, 33-1/3rpm), and Adjust VR1 so that the speed is $1000 \pm 10\text{Hz}$.
- 4) Set the speed Selector to 45rpm.
- 5) Play back the Test Record (1000Hz, 45rpm), and adjust VR2 so that the speed is $1000 \pm 10\text{Hz}$.

NOTE:

This Speed Adjustment should be adjust 33-1/3rpm position first then adjust 45rpm next.

VII. P.C BOARD TITLES AND IDENTIFICATION NUMBERS

PC BOARD TITLE	PC BOARD NUMBER	REMARKS
MOTOR PC BOARD	G-80	
JUNCTION (1) PC BOARD	P1047D501A	
JUNCTION (2) PC BOARD	P1047D501B	



SECTION 2

SERVICE MANUAL

MODEL AP-A200/C

TABLE OF CONTENTS

I. SPECIFICATIONS	12
II. DISMANTLING OF UNIT	12
III. CONTROLS	13
IV. PRINCIPAL PARTS LOCATION	14
V. HOW TO CHANGE OR INSTALL THE CARTRIDGE	14
VI. MECHANICAL ADJUSTMENT	15
1. TONE ARM HEIGHT ADJUSTMENT	15
2. AUTO-RETURN ADJUSTMENT (Refer to Fig. 6-1)	15
3. RETURN ARM POSITION ADJUSTMENT (Refer to Fig. 6-3 & 6-4)	15
VII. ELECTRICAL ADJUSTMENT	16
1. SPEED ADJUSTMENT	16
VIII. PC BOARD TITLES AND IDENTIFICATION NUMBERS	16

For basic adjustments, measuring methods, and operating principles, refer to GENERAL TECHNICAL MANUAL.

I. SPECIFICATIONS

TURNTABLE (PLATTER)	Aluminum alloy diecast
DRIVE SYSTEM	Direct Drive Semi-automatic
MOTOR	FG Servo DC motor
SPEED	33-1/3 & 45 rpm
WOW & FLUTTER	0.045% (WRMS)
RUMBLE	70dB (DIN-B)
TONE ARM	Static balanced type
EFFECTIVE ARM LENGTH	220mm
STYLUS PRESSURE ADJUSTMENT	Oil damped
STYLUS RANGE ADJUSTMENT	1.25g (Final)
APPLICABLE CARTRIDGE WEIGHT	(TP) Plug in Type)
CARTRIDGE (AP-200C only)	VM type (PC-35/ TP) Plug in Type)
OUTPUT VOLTAGE	2.5mV
CHANNEL SEPARATION	More than 20dB
OPTIMAL STYLUS PRESSURE	1.25g
DIMENSIONS	440(W) x 346.5(D) x 94(H) mm (17.3 x 13.6 x 3.7 inches)
WEIGHT	3.2kg (7.0 lbs)

* For improvement purposes, specifications and design are subject to change without notice.

II. DISMANTLING OF UNIT

In case of trouble, etc. necessitating dismantling, please dismantle in the order shown in the photographs. Reassemble in reverse order.

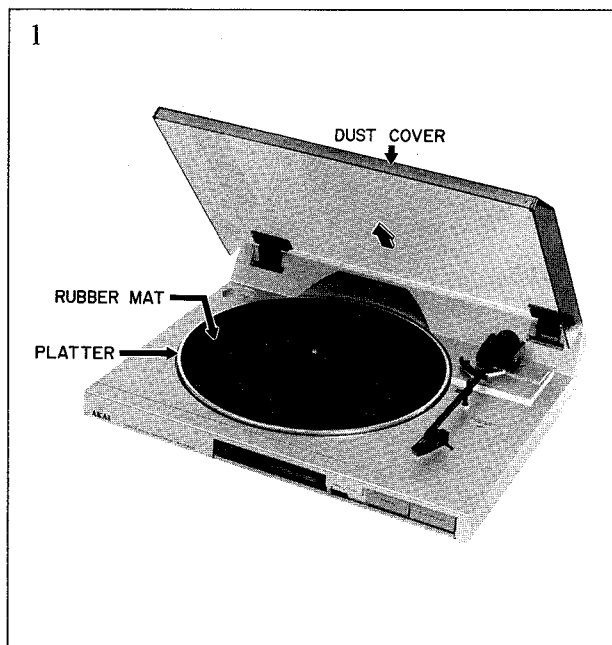

III. CONTROLS

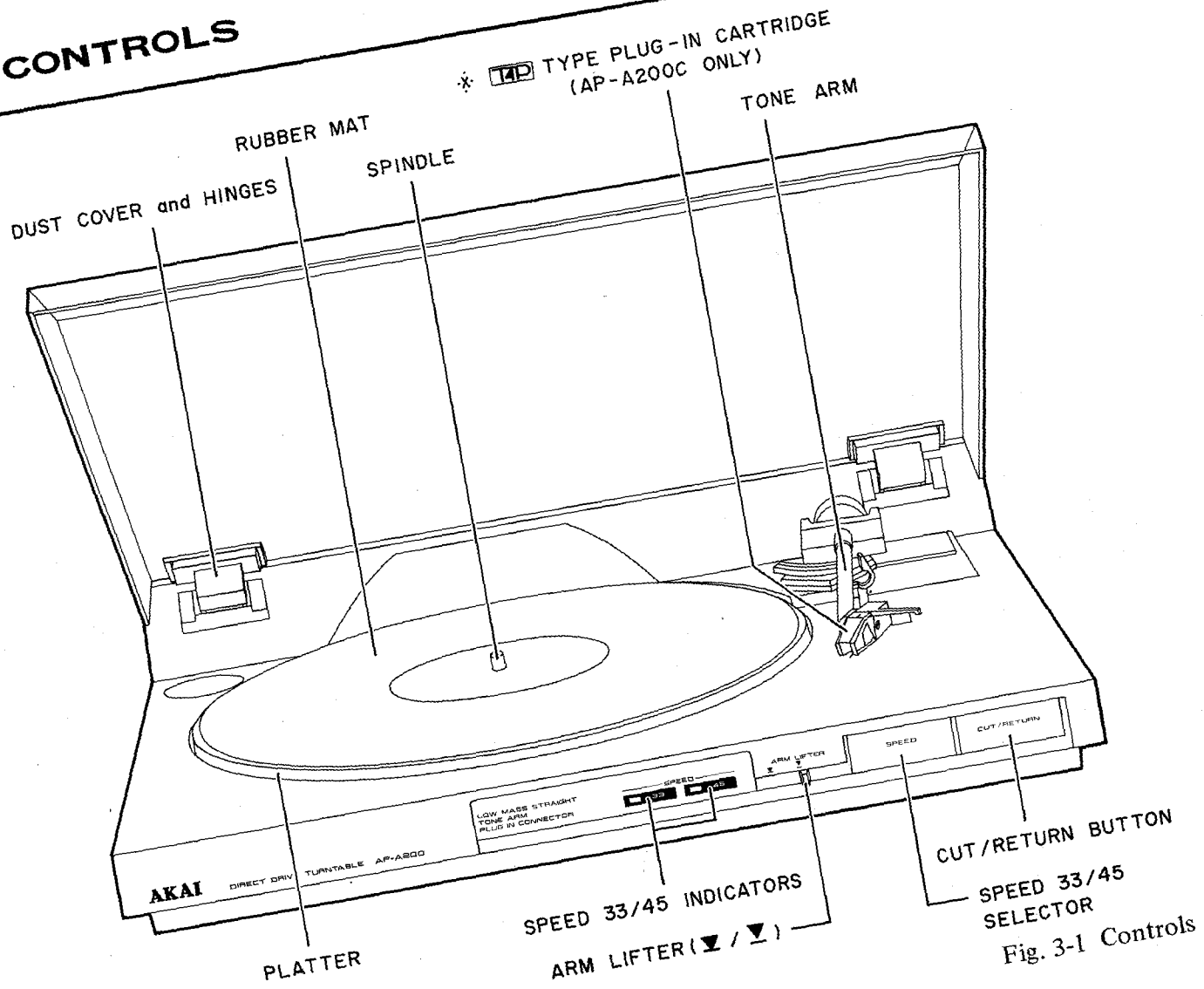

IV. PRINCIPAL PARTS LOCATION

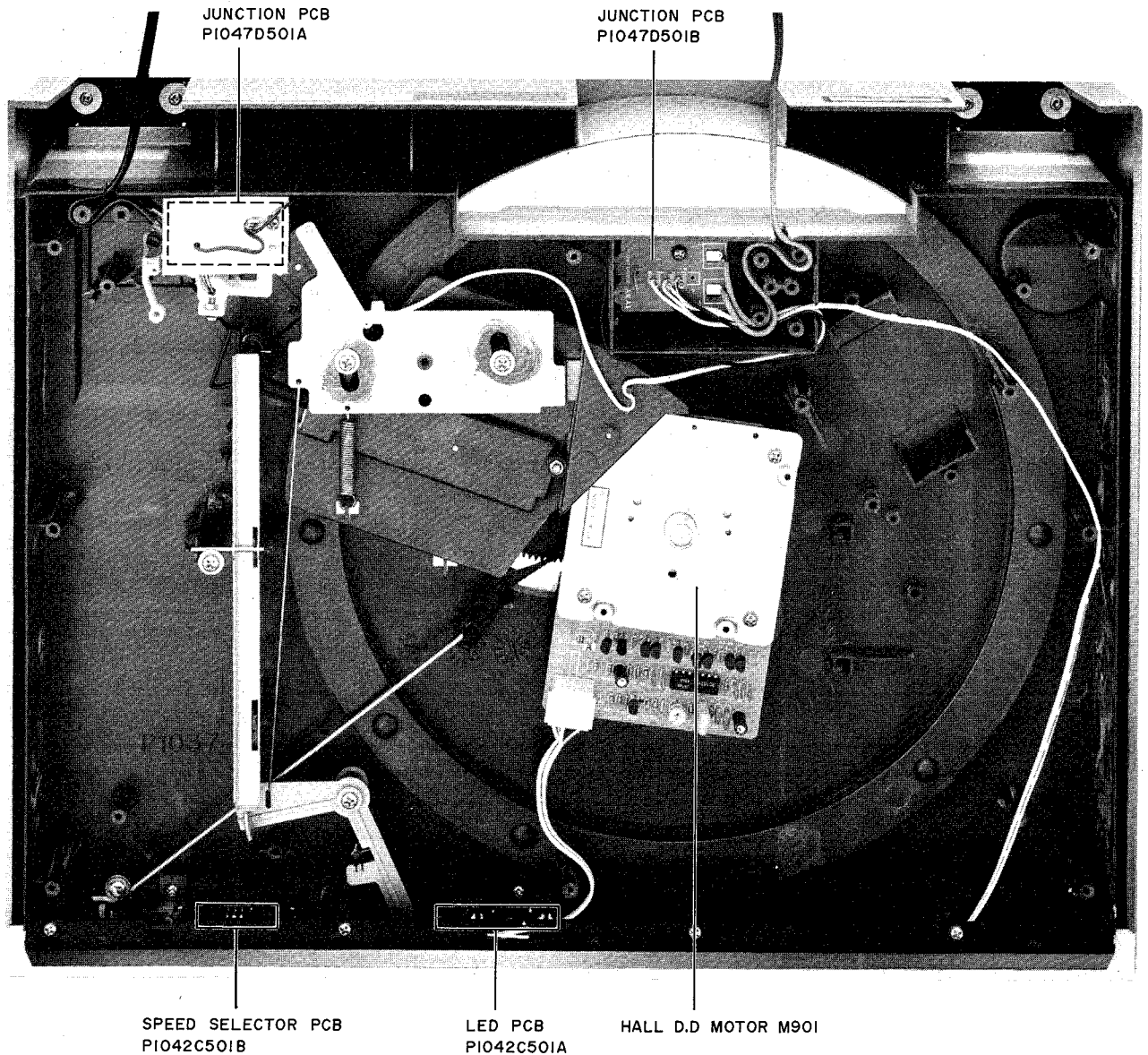

Fig. 4-1 Bottom Side View

V. HOW TO CHANGE OR INSTALL THE CARTRIDGE

With the tone arm on the tone arm rest and clamped, remove the screw on the side of the tone arm—directly behind the cartridge—by using a screwdriver.

After removing the screw, grasp the cartridge firmly and pull it forward, away from the tone arm, until it is free. Replace the new cartridge by reversing the above operation.

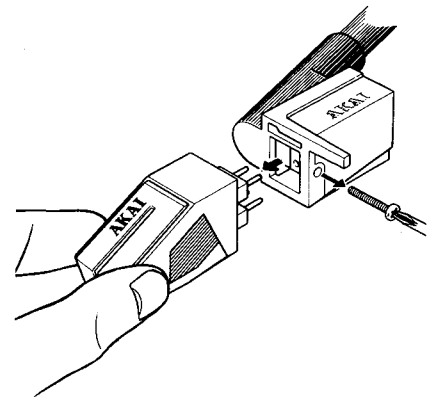

Fig. 5-1

VI. MECHANICAL ADJUSTMENT

6-1. TONE ARM HEIGHT ADJUSTMENT

* WHEN AUTO-CUT (Auto-Return) MODE (Refer to Figs. 6-1 and 6-2).

Set the play mode, and push the Cut Button. While returning the Tone Arm, confirm the height of the Tone Arm, so that the height are 0.5 to 1.0 mm from flat face of Tone Arm Rest.

If the height is without 0.5 to 1.0 mm, adjust Tone Arm Lifter Height Adjustment screw.

Counterclockwise: Up
Clockwise: Down

6-2. AUTO-RETURN ADJUSTMENT

(Refer to Fig. 6-1)

If the Tone Arm does not return automatically to the Tone Arm Rest at the end of the playback, or does so during playback:

- 1) Leave the Power Cord connected.
- 2) Adjust the Auto-Return Adjustment Screw.
Turn clockwise:
If the Tone Arm returns before the end of record.
Turn counterclockwise:
If the Tone Arm does not return at the end of record.

* Do not turn the screw counterclockwise too much.

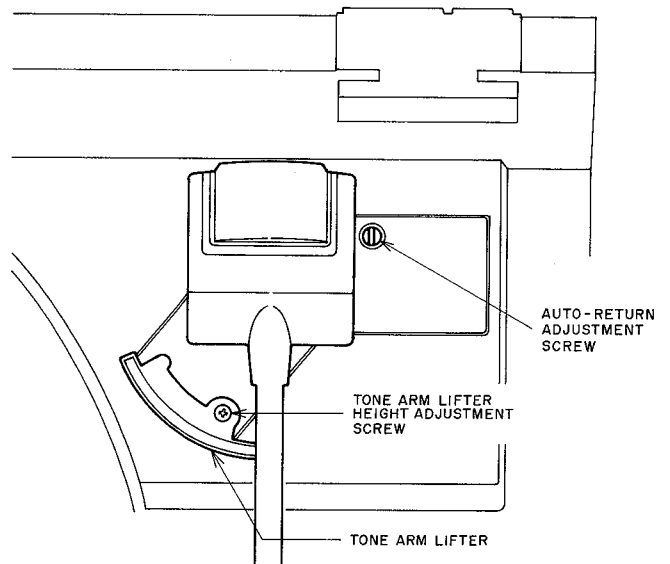

Fig. 6-1

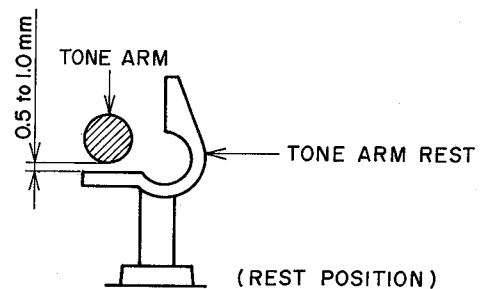

Fig. 6-2

6-3. RETURN ARM POSITION ADJUSTMENT (Refer to Figs. 6-3 & 6-4)

After, replaced the Tone Arm, PU LEVER position Adjustment is necessary as follow.

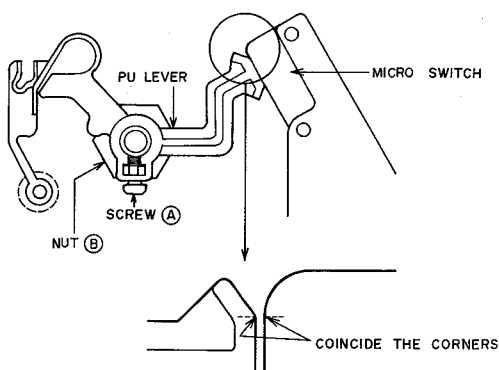

Fig. 6-3

- 1) Lock the Tone Arm on the ARM REST.
- 2) Loosen the Screw A, and confirm that the PU LEVER is installed all the way in the Nut B.
- 3) Turn the PU LEVER so that the corner of those PU LEVER and Micro switch are coincide as shown in Fig. 6-3.
- 4) Tighten the Screw A.
- 5) Move the Tone Arm to the spindle side, and confirm that micro switch is switched "ON" at about center between Tone Arm Rest position and platter as shown in Fig. 6-4.

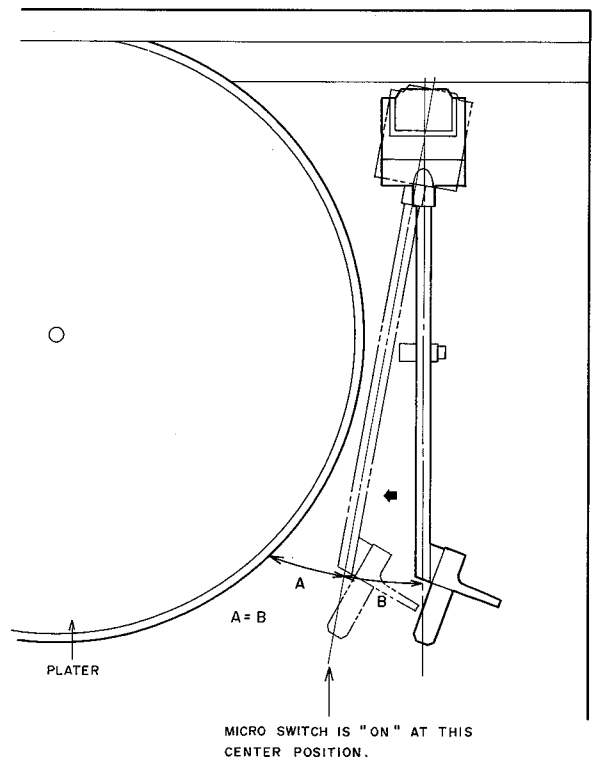

Fig. 6-4

VII. ELECTRICAL ADJUSTMENT

7-1. SPEED ADJUSTMENT

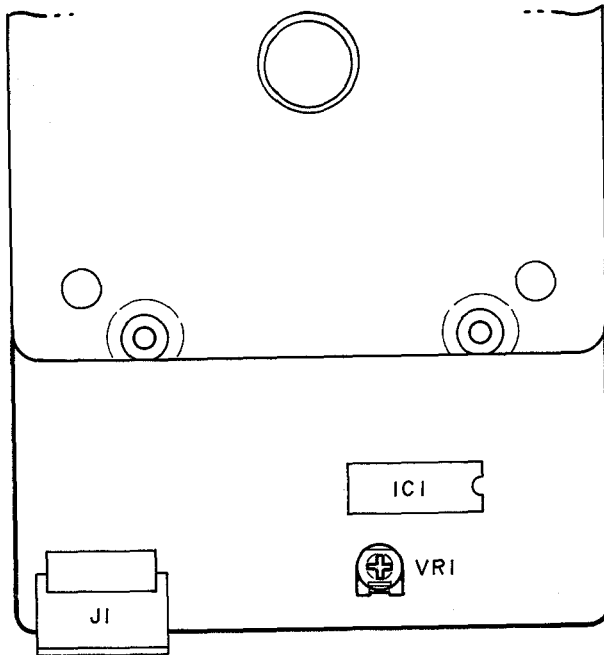
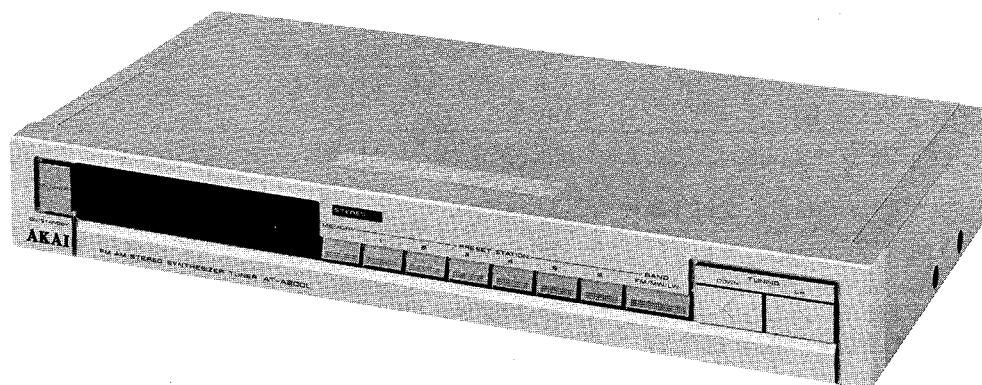

Fig. 7-1

- 1) Set the Speed Selector to 33-1/3rpm.
- 2) Playback the Test Record (33-1/3rpm, 1000Hz).
- 3) Adjust VR1 (10kohms) so that the speed is 1000 \pm 10Hz.
- 4) Set the Speed Selector to 45rpm.
- 5) Playback the Test Record (45rpm, 1000Hz).
- 6) Confirm that the Speed is 1000 \pm 10Hz.

VIII. P.C BOARD TITLES AND IDENTIFICATION NUMBERS

PC BOARD TITLE	PC BOARD NUMBER	REMARKS
LED PC BOARD	P1042C501A	
SPEED SELECTOR PC BOARD	P1042C501B	
JUNCTION (A) PC BOARD	P1047D501A	
JUNCTION (B) PC BOARD	P1047D501B	



SECTION 3

SERVICE MANUAL

MODEL AT-A200/L

TABLE OF CONTENTS

I.	SPECIFICATIONS	18
II.	DISMANTLING OF UNIT	18
III.	CONTROLS	19
IV.	PRINCIPAL PARTS LOCATION	19
V.	ELECTRICAL ADJUSTMENT	20
	1. INSTRUMENT CONNECTIONS FOR TUNER ADJUSTMENT	20
	2. TUNER PCB ADJUSTMENT POINT	20
	3. FM SECTION ADJUSTMENTS	21
	4. LW SECTION ADJUSTMENTS (AT-A200L ONLY)	21
	5. AM (MW) SECTION ADJUSTMENT	22
VI.	PC BOARD TITLES AND IDENTIFICATION NUMBERS	22

For basic adjustments, measuring methods, and operating principles, refer to GENERAL TECHNICAL MANUAL.

I. SPECIFICATIONS

FM TUNER SECTION

TUNING FREQUENCY RANGE	87.5MHz to 108.0MHz
USABLE SENSITIVITY (300ohms)	12.7dBf
QUIETING SENSITIVITY (S/N=50dB)	19.2dBf (Mono)/40.2dBf (Stereo)
CAPTURE RATIO	2.0dB
SELECTIVITY (400kHz)	60dB
IMAGE REJECTION	50dB
IF REJECTION	80dB
SPURIOUS REJECTION	80dB
AM SUPPRESSION	50dB
SUB CARRIER SUPPRESSION	55dB
S/N (IHF)	70dB (Mono)/60dB (Stereo)
T.H.D.	0.2% (Mono)/0.4% (Stereo)
STEREO SEPARATION (1kHz)	40dB
FREQUENCY RESPONSE	30Ha to 15kHz \pm 1.0dB

AM TUNER SECTION (MW & LW FOR AT-A200L)

TUNING FREQUENCY RANGE	AM tuner section	LW tuner section
USA & CANADA	530kHz to 1,610kHz	—
OTHER COUNTRIES	531kHz to 1,602kHz	146kHz to 353kHz
USABLE SENSITIVITY (LOOP ANTENNA)	300uV/m	800uV/m
SELECTIVITY	30dB	40dB
IMAGE REJECTION	45dB	45dB
IF REJECTION	35dB	35dB
S/N	40dB	35dB
T.H.D.	1.0%	2.0%
OUTPUT SECTION		
OUTPUT LEVEL FM	700mV (100% Mod.)	
AM (MW FOR AT-A200L)	250mV (30% Mod.)	
DIMENSIONS	440(W) x 66(H) x 210(D) mm (17.3 x 2.6 x 8.3 inches)	
WEIGHT	1.6kg (3.5 lbs)	

* For improvement purposes, specifications and design are subject to change without notice.

II. DISMANTLING OF UNIT

In case of trouble, etc. necessitating dismantling, please dismantle in the order shown in the photographs. Reassemble in reverse order.

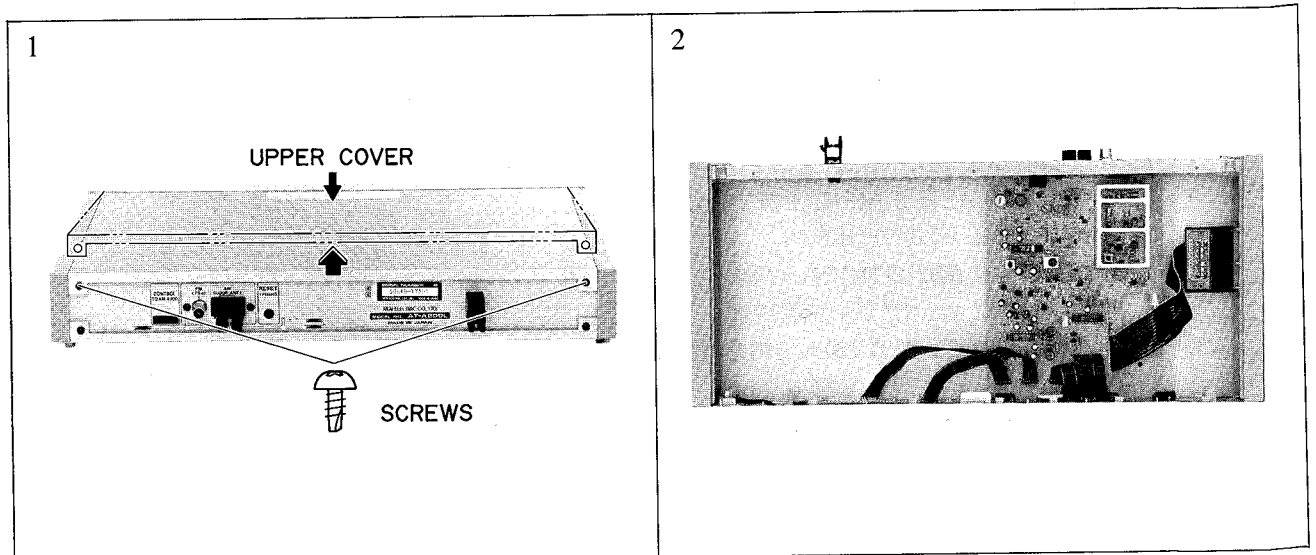

III. CONTROLS

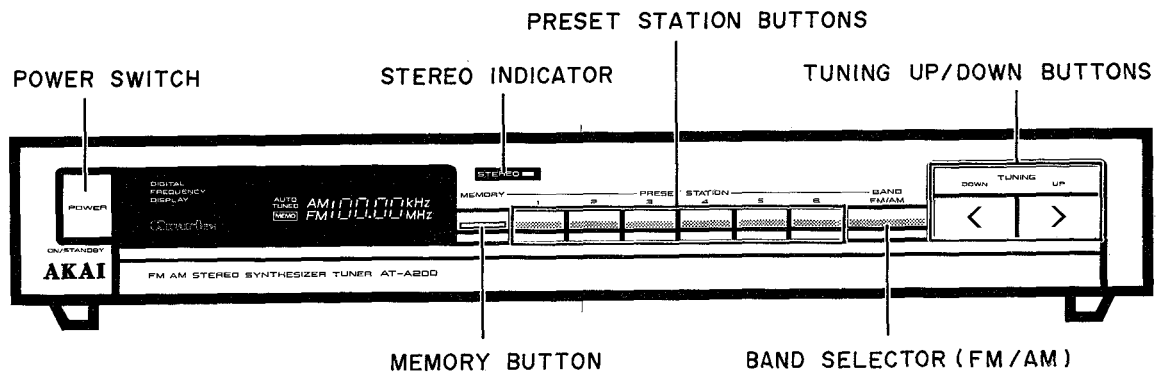

Fig. 3-1 Control

IV. PRINCIPAL PARTS LOCATION

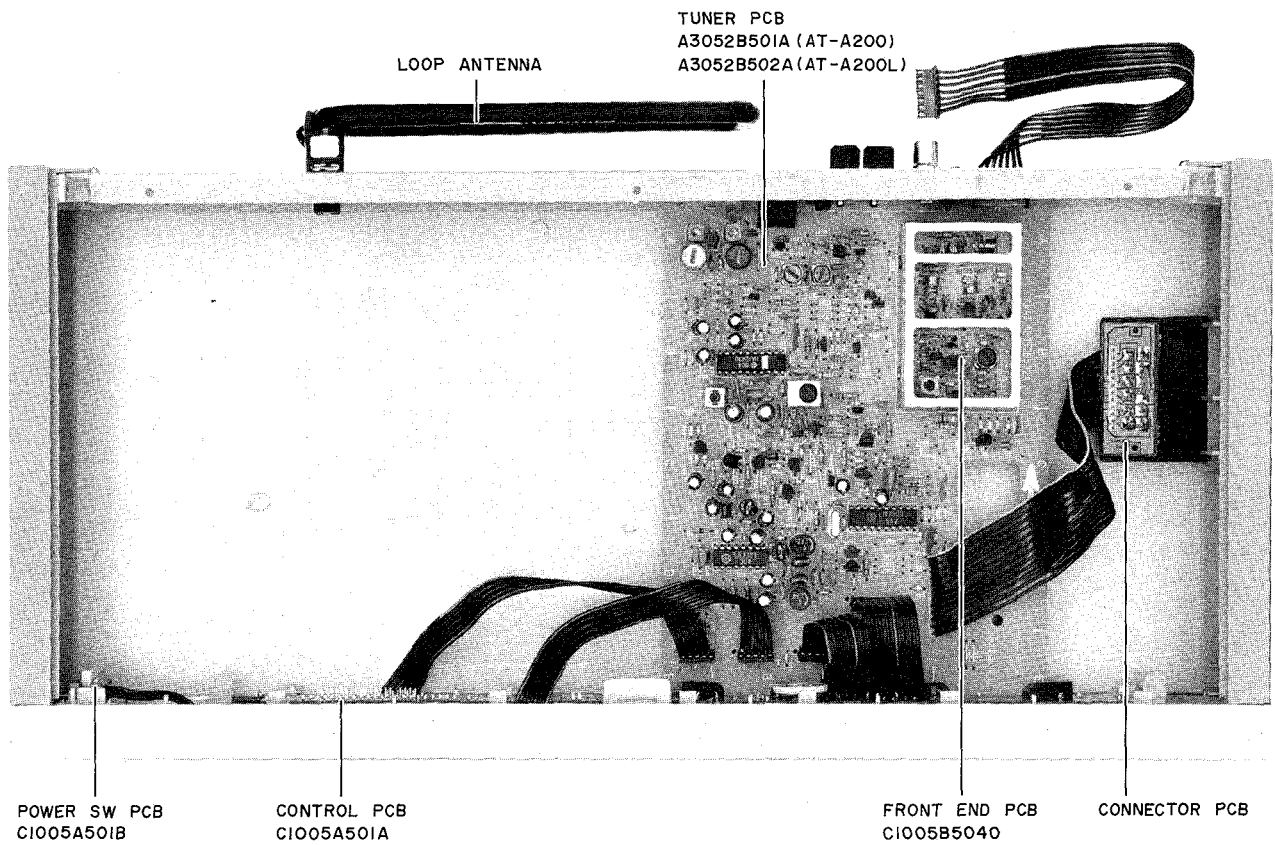

Fig. 4-1

V. ELECTRICAL ADJUSTMENT

5-1. INSTRUMENT CONNECTIONS FOR TUNER ADJUSTMENT

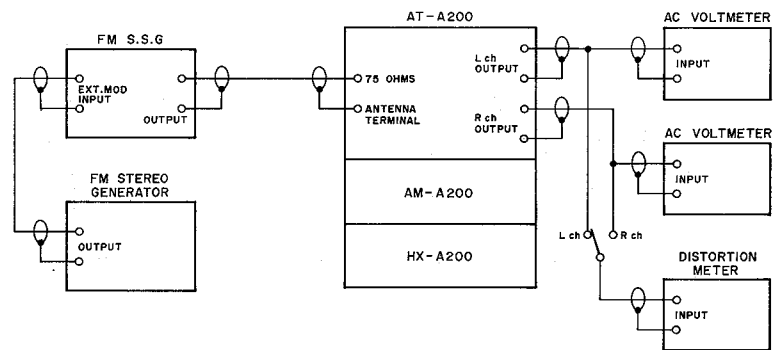

Fig. 5-1 Instrument Connections for FM Section Adjustment

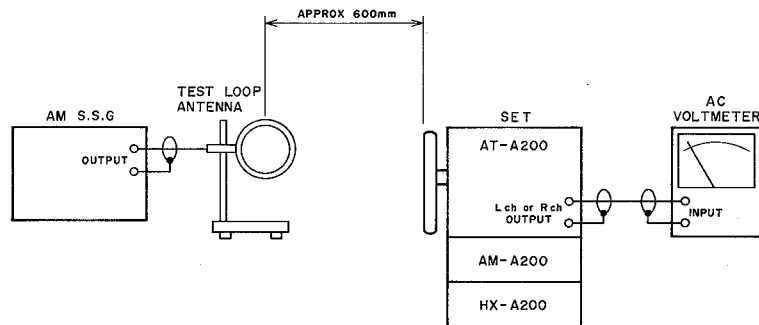

Fig. 5-2 Instrument Connections for AM (MW, LW) Section Adjustment

5-2. TUNER PCB ADJUSTMENT POINT

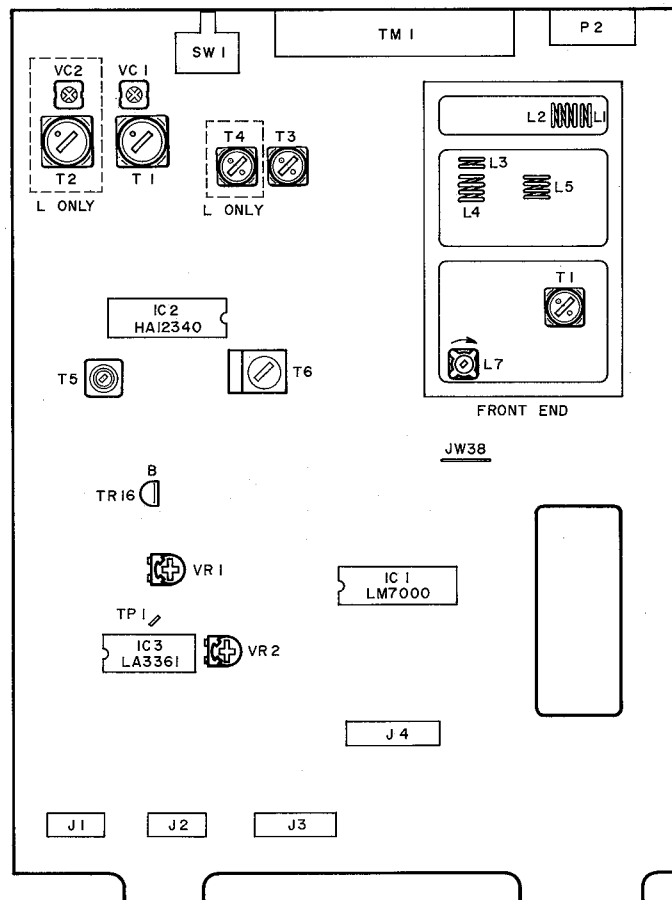

Fig. 5-3 Tuner PCB (Parts Side View)

5-3. FM SECTION ADJUSTMENTS

- NOTE: 1. Set the S.S.G to 1kHz, 75kHz deviation for U, C, A, S 40kHz deviation for B, E, V.
 2. Set the Band Switch to FM.
 3. (MHz) indicate for B, E, V model.
 4. 0dBu = 1uV

Step	Adjustment Item	S.S.G.	SET	Adjustment Parts	Result	Remarks
		Freq./ATT	Tuning			
1	FM OSC	—	87.5MHz	L7 (Front End)	3.5±0.05V	1) Connect a Digital Volt Meter between JW38 and GND.
2	Low Range Sensitivity	88MHz 10dBu (MONO)	88MHz	L2,L4,L5 (Front End)	Less than 3% Distortion	1) Connect a wire between Base of TR16 and GND. (Mute OFF)
3	High Sensitivity	108MHz 10dBu (MONO)	108MHz	L2,L4,L5 (Front End)	Less than 3% Distortion	1) Connect a wire between Base of TR16 and GND. (Mute OFF)
4	For best Result, Repeat steps 2 and 3 two or three times.					
5	Distortion (MONO)	88MHz 60dBu (MONO)	88MHz	T5	Less than 1% Distortion	
6	MPX Free Running Frequency	—	—	VR1	19kHz±50Hz	1) Connect a Frequency counter between TP1 and GND.
7	Distortion (Stereo)	98MHz 60dBu Stereo Lch (Rch)	98MHz (100MHz)	T1 (Front End)	Less than 1% Distortion	See Note 3
8	Stereo Separation	98MHz 60dBu 'Stereo Lch (Rch)	98MHz	VR2	More than 35dBm Minimum Output of Rch (Lch)	

5-4. LW SECTION ADJUSTMENTS (AT-A200L ONLY)

- NOTE: 1) Set the S.S.G. to 1kHz 30% modulation.

Step	Adjustment Item	S.S.G.	SET	Adjustment Parts	Result	Remarks
		Freq./ATT	Tuning			
1	LW OSC	—	300kHz	T4	5.82±0.05V	1) Connect a Digital Volt Meter between JW38 and GND.
2	Low Range Sensitivity	160kHz 65dBu	160kHz	T2,T6	Less than 10% Distortion	
3	High Range Sensitivity	300kHz 65dBu	300kHz	VC2	Less than 10% Distortion	
4	For best Result, Repeat steps 2 and 3 two or three times.					
5	Distortion Confirmation	200kHz 74dBu	200kHz	None	Less than 3% Distortion	

5-5. AM (MW) SECTION ADJUSTMENT

NOTE: 1) Set the S.S.G. to 1kHz 30% modulation.
 2) (kHz) in S.S.G. frequency and set tuning indicates the Test Frequency in AM 9kHz STEP Area.

AM (MW)

Step	Adjustment Item	S.S.G.	SET	Adjustment Parts	Result	Remarks
		Freq./ATT	Tuning			
1	AM (MW) OSC	—	1400kHz (1404kHz)	T3	6.7±0.1V	1) Connect a Digital Volt Meter between JW38 and GND.
2	Low Range Sensitivity	600kHz (603kHz) 60dBu	600kHz (603kHz)	T1,T6	Less than 10% Distortion	
3	High Range Sensitivity	1400kHz (1404kHz) 60dbu	1400kHz (1404kHz)	VC1	Less than 10% Distortion	
4	For best Result, Repeat steps 2 and 3 two or three times.					
5	Distortion (Confirmation)	1000kHz (999kHz) 74dBu	1400kHz (999kHz)	None	Less than 2% Distortion	

VI. PC BOARD TITLES AND IDENTIFICATION NUMBERS

PC BOARD TITLE		PC BOARD NUMBER	REMARK
TUNER	PC BOARD	A3052B501A	AT-A200
TUNER	PC OBARD	A3052B502A	AT-A200L
CONNECTOR	PC BOARD	A3052B502B	
CONTROL	PC BOARD	C1005A501A	
POWER SW	PC BOARD	C1005A501B	
FRONT END	PC BOARD	C1005B5040	

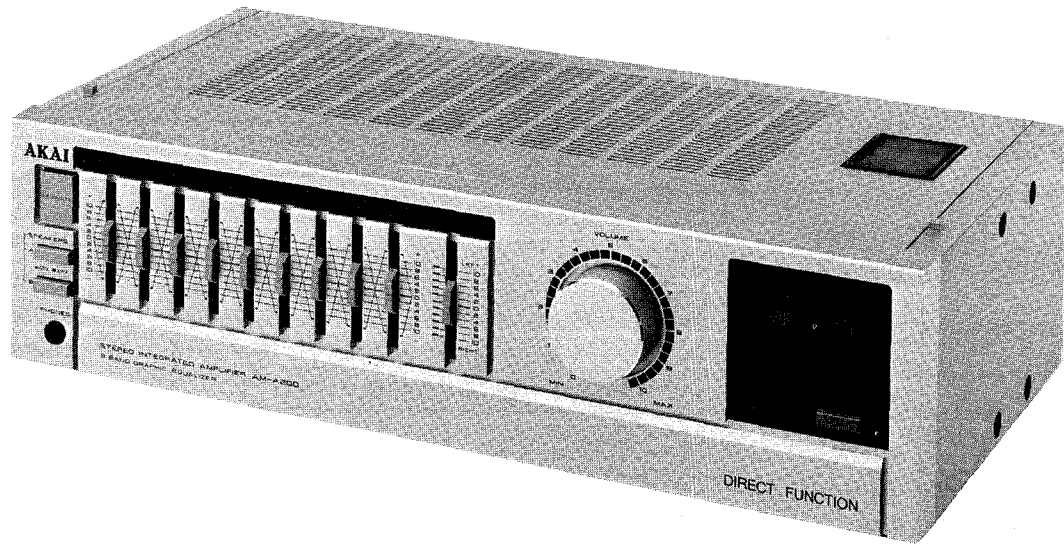

SECTION 4

SERVICE MANUAL

MODEL AM-A200

TABLE OF CONTENTS

I. SPECIFICATIONS	24
II. DISMANTLING OF UNIT	24
III. CONTROLS	25
IV. PRINCIPAL PARTS LOCATION	25
V. ADJUSTMENT	26
VI. PC BOARD TITLES AND IDENTIFICATION NUMBERS	26

For basic adjustments, measuring methods, and operating principles; refer to GENERAL TECHNICAL MANUAL.

I. SPECIFICATIONS

POWER AMPLIFIER SECTION

	8ohms
RATED POWER OUTPUT 40Hz to 20kHz	35W/0.3%
POWER OUTPUT (BY FTC) 20Hz to 20kHz	35W/0.3%
FRENCH NORMAL (8ohms) 63Hz to 12.5kHz	40W/0.7%
DIN 1kHz	40W/0.7%
MUSIC POWER (BOTH CHANNELS)	180W
POWER BANDWIDTH (IHF -3dB, 8ohms)	10Hz to 40kHz (0.5%)
S/N (IHF-A) PHONO	70dB
AUX	90dB
RESIDUAL NOISE (8ohms)	0.5mV
CHANNEL SEPARATION (IHF, 1kHz)	50dB
DAMPING FACTOR (1kHz, 8ohms)	30
REQUIRED SPEAKER IMPEDANCE	A or B 8 to 16ohms A and B 8 to 16ohms

PRE AMPLIFIER SECTION

INPUT SENSITIVITY/IMPEDANCE	PHONO CD/VTR	2.0mV/47kohms 250mV/47kohms
FREQUENCY RESPONSE		
PHONO (RIAA DEVIATION)		±0.5dB
TUNER, AUX, TAPE		5Hz to 100kHz (-3dB)
GRAPHIC EQUALIZER		
TYPE		9 bands
CENTER FREQUENCY		63Hz/125Hz/250Hz/500Hz/1kHz/2kHz/4kHz 8kHz 16kHz
CONTROL RANGE		±10dB

* For improvement purposes, specifications and design are subject to change without notice.

II. DISMANTLING OF UNIT

In case of trouble, etc. necessitating dismantling, please dismantle in the order shown in the photographs. Reassemble in reverse order.

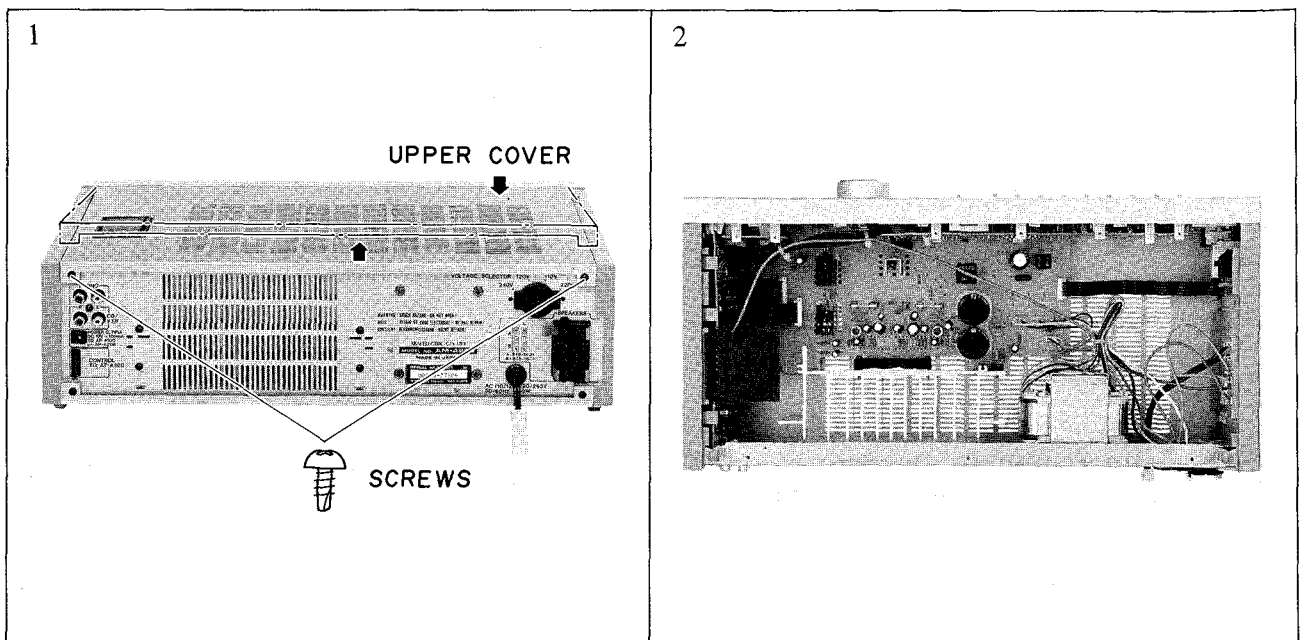

III. CONTROLS

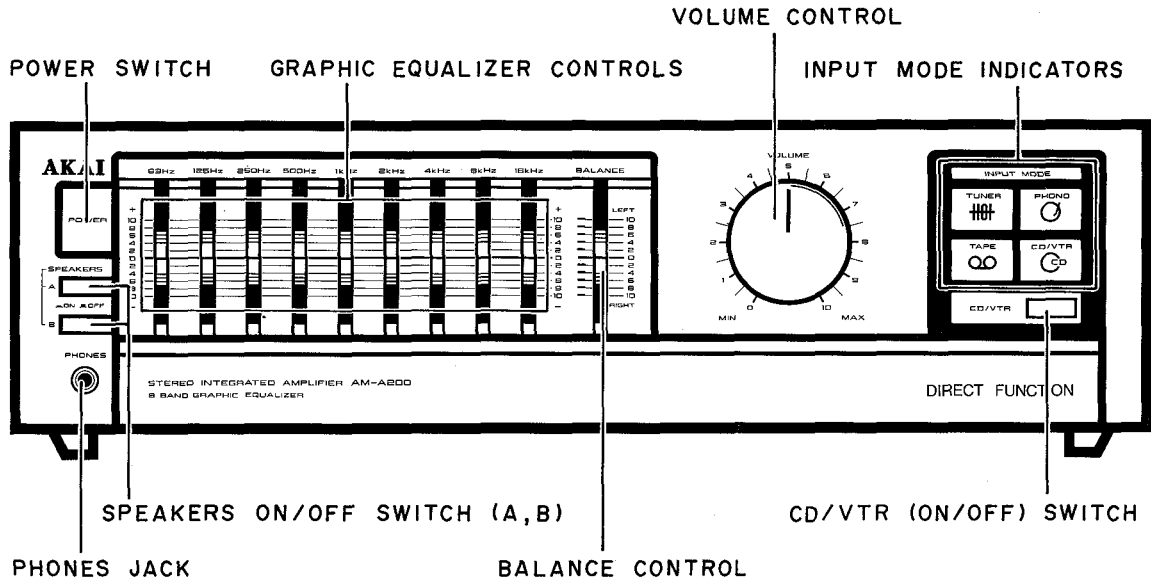

Fig. 3-1 Control

IV. PRINCIPAL PARTS COCATION

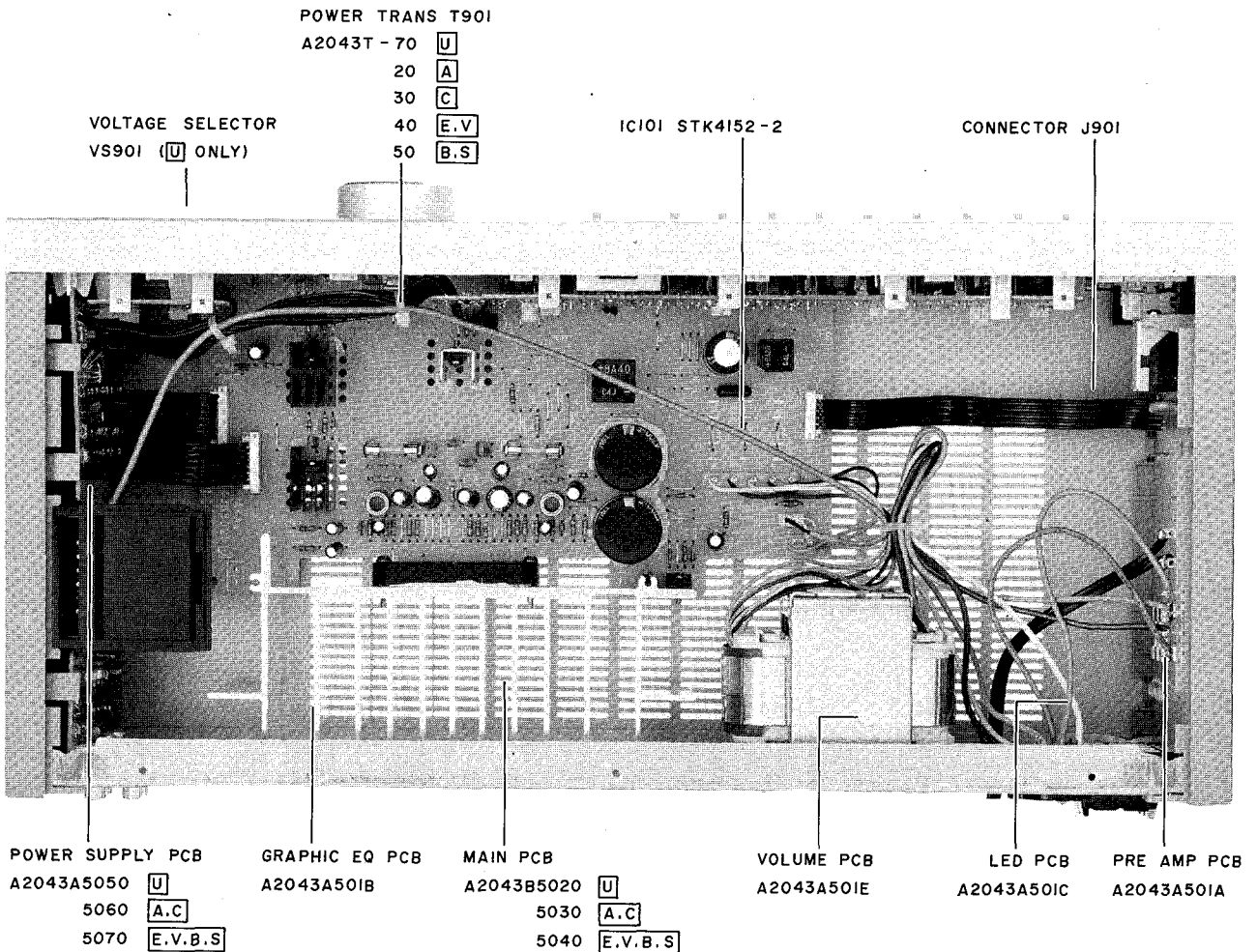

Fig. 4-1

V. ADJUSTMENT

No Adjustment is necessary for this model.

VI. PC BOARD TITLES AND IDENTIFICATION NUMBERS

PC BOARD TITLE	PC BOARD NUMBER	REMARKS
MAIN PC BOARD	A2043B5020	U
	5030	C, A
	5040	E, V, B, S
POWER SUPPLY PC BOARD	A2043A5050	U
	5060	A, C
	5070	E, V, B, S
PRE AMP PC BOARD	A2043A501A	
GRAPHIC EQ PC BOARD	501B	
LED PC BOARD	501C	
VOLUME PC BOARD	501D	
CONNECTOR (A) PC BOARD	501E	
CONNECTOR (B) PC BOARD	501F	

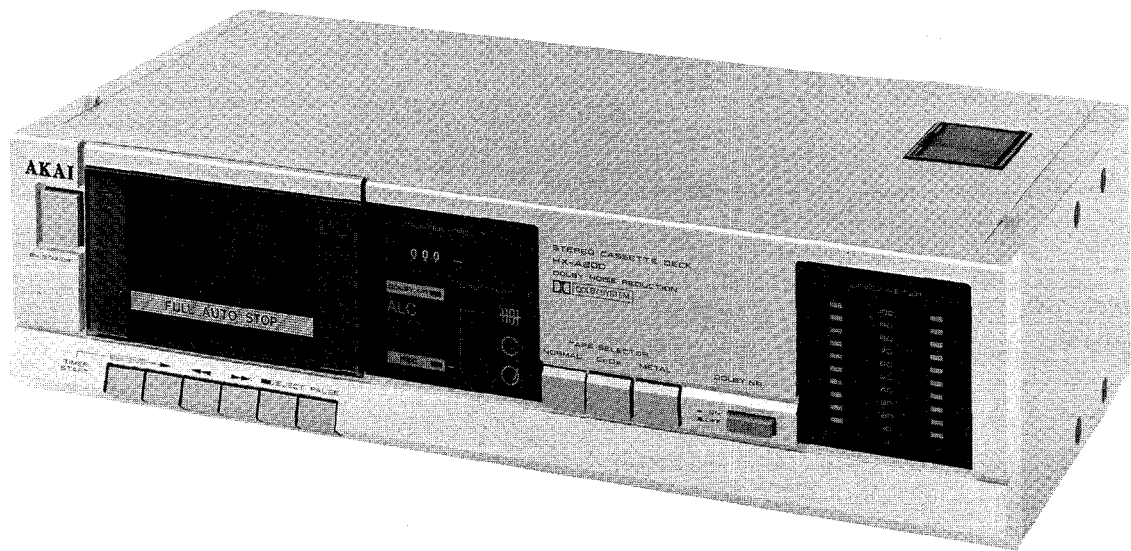

SECTION 5

SERVICE MANUAL

MODEL HX-A200

TABLE OF CONTENTS

I. SPECIFICATIONS	28
II. DISMANTLING OF UNIT	28
III. CONTROLS	29
IV. PRINCIPAL PARTS LOCATION	29
V. MECHANICAL ADJUSTMENT	30
1. PINCH ROLLER PRESSURE MEASUREMENT	30
2. WINDING TORQUE MEASUREMENT IN EACH MODE	30
3. TAPE SPEED ADJUSTMENT	30
4. REC/PB HEAD AZIMUTH ADJUSTMENT	30
VI. ELECTRICAL ADJUSTMENT	31
VII. PC BOARD TITLES AND IDENTIFICATION NUMBERS	33

For basic adjustments, measuring methods, and operating principles, refer to GENERAL TECHNICAL MANUAL.

I. SPECIFICATIONS

TRACK SYSTEM	4 track 2 channel stereo
TAPE	Phillips type cassette
HEADS	HD head for recording and playback x1 Erase head x1
MOTOR	Electronically speed controlled DC motor x1
WOW & FLUTTER	0.05% WRMS (JIS), 0.12% (DIN)
FREQUENCY RESPONSE	
NORMAL	30Hz to 15,000Hz ±3dB
CrO ₂	30Hz to 16,000Hz ±3dB
METAL	30Hz to 17,000Hz ±3dB
S/N	56dB Dolby NR switch ON: improves up to 5dB at 1kHz, 10dB above 5kHz
HARMONIC DISTORTION	Less than 0.7%
DIMENSIONS	440(W) × 115(H) × 210(D) mm (17.3 × 4.5 × 8.3 inches)
WEIGHT	2.7kg (6.0 lbs)

* For improvement purposes, specifications and design are subject to change without notice.

* Noise Reduction manufactured under license from Dolby Laboratories Licensing corporation. "Dolby" and the double-D Symbol are trade marks of Dolby Laboratories Licensing Corporation.

II. DISMANTLING OF UNIT

In case of trouble, etc. necessitating dismantling, please dismantle in the order shown in the photographs. Reassemble in reverse order.

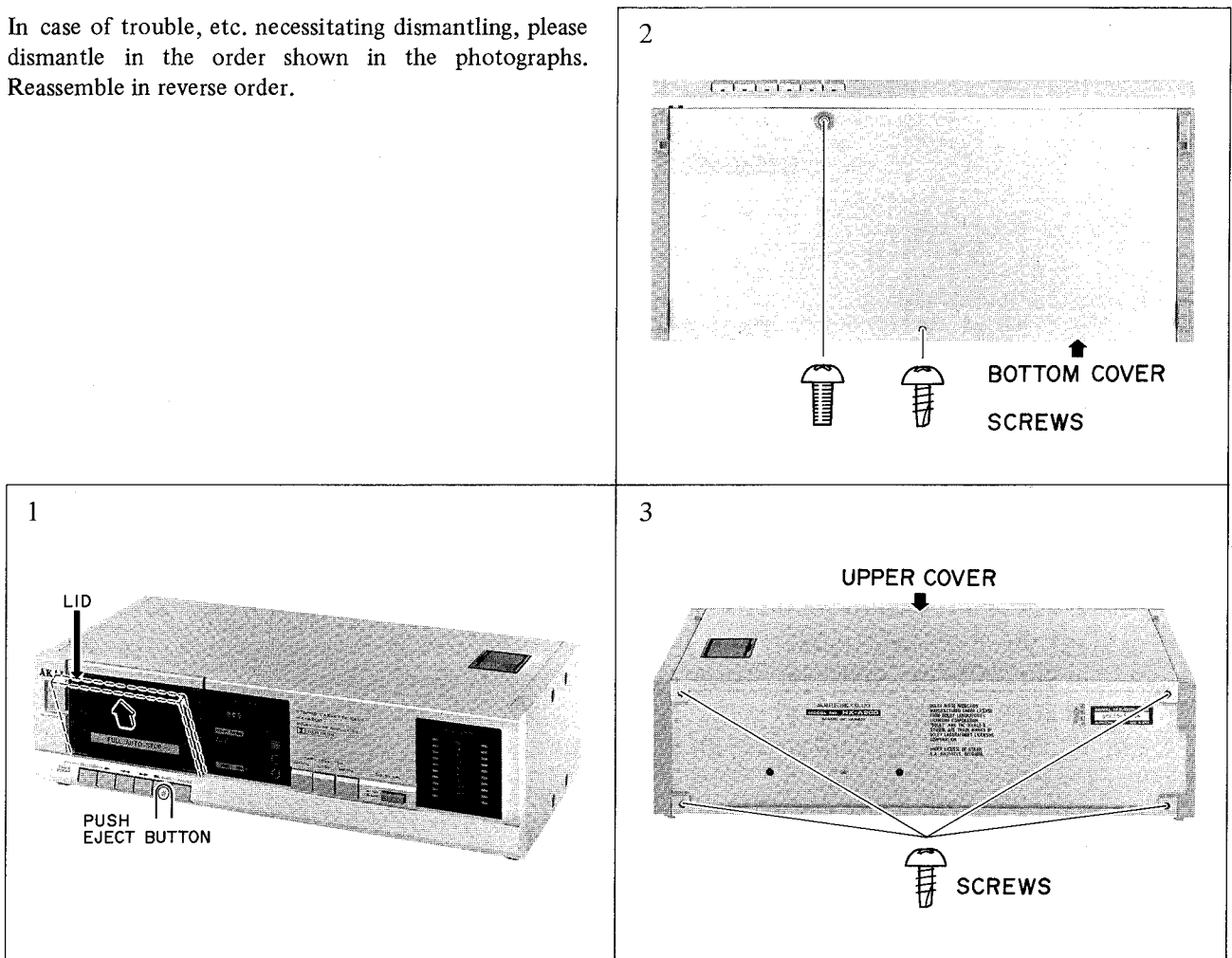

III. CONTROLS

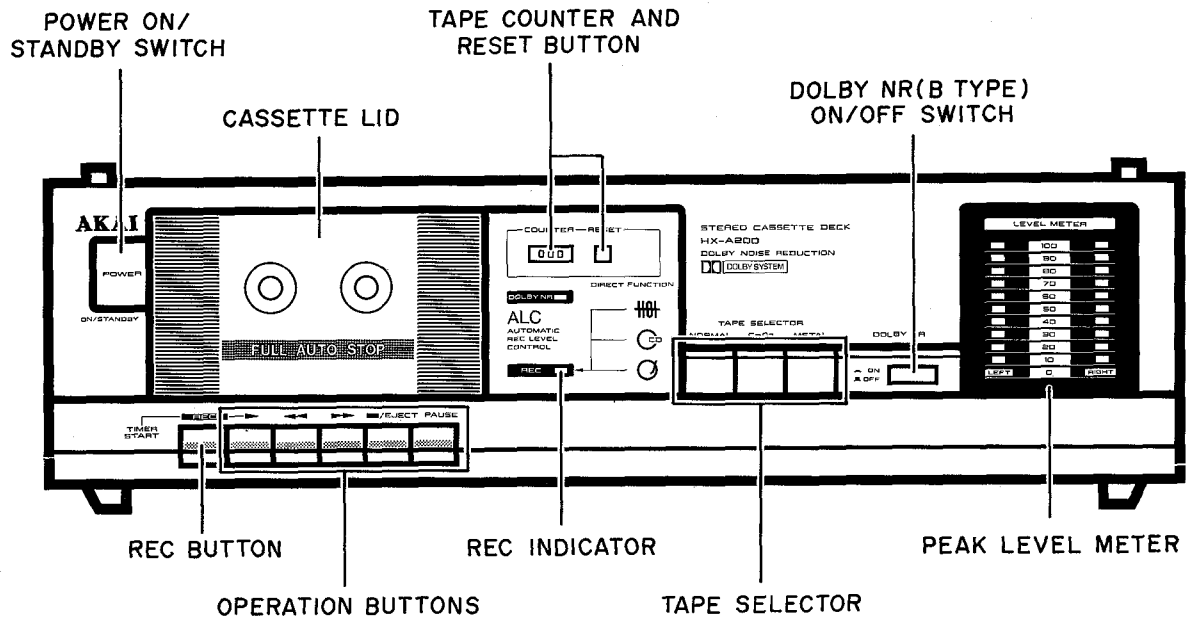

Fig. 3-1 Control

IV. PRINCIPAL PARTS LOCATION

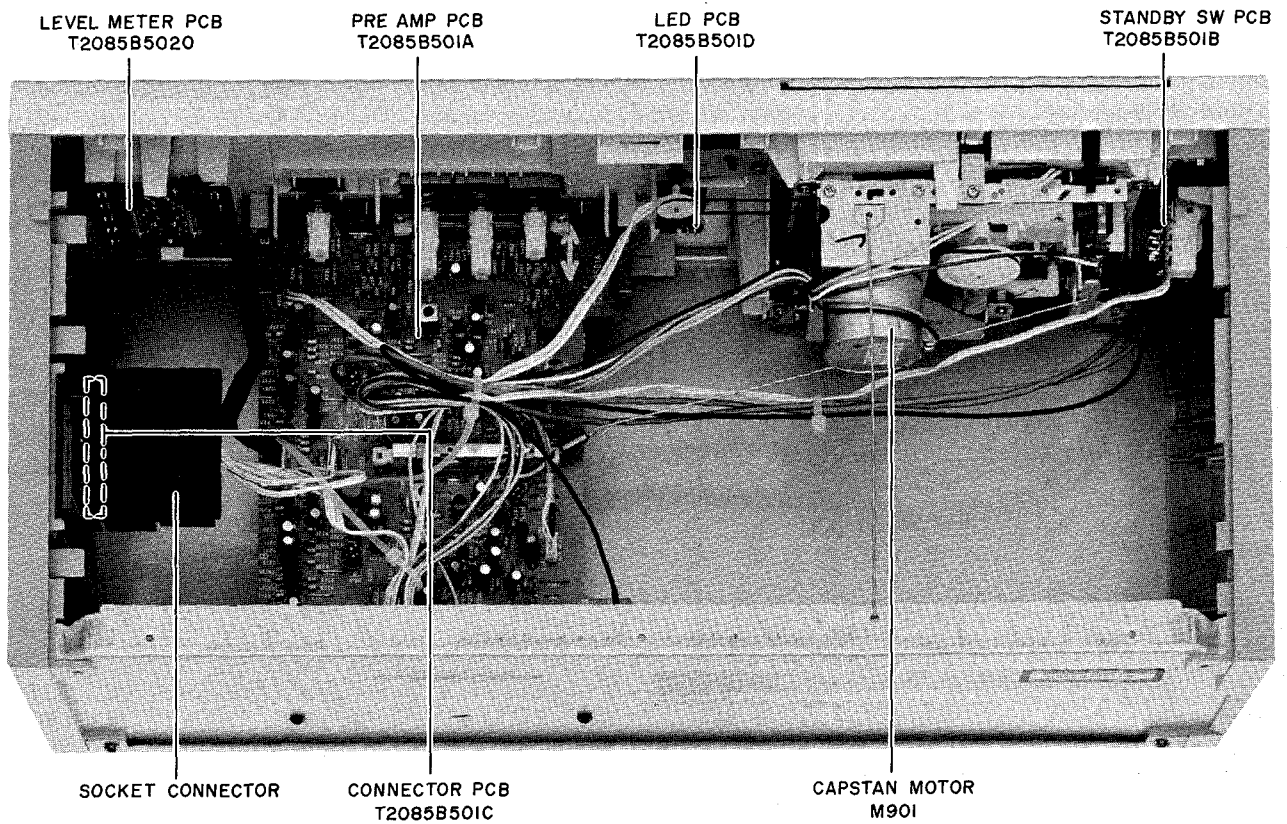

Fig. 4-1 Top View

V. MECHANICAL ADJUSTMENT

5-1. PINCH ROLLER PRESSURE MEASUREMENT

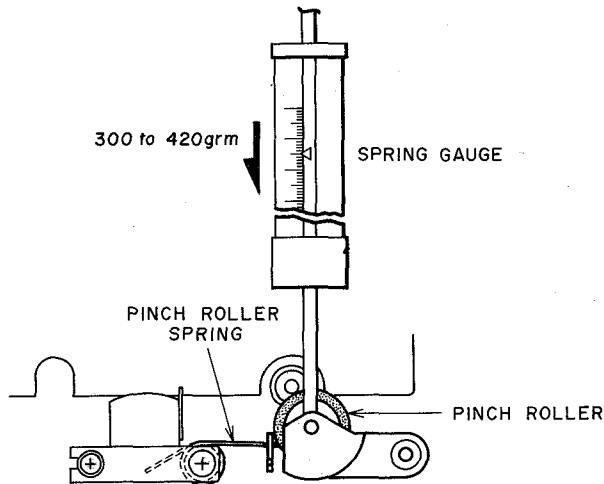

Fig. 5-1

Put in PLAY mode. Push pinch roller arm down with the spring gauge, push the pinch Roller 1 to 2 mm from the Capstan and release slowly.

Read the spring gauge at the moment the pinch roller touches the capstan and begins to rotate. Specified contact pressure measurement of 200 to 400 gm. If there is no measurement obtained, Adjust or Replace the pinch Roller spring.

5-2. WINDING TORQUE MEASUREMENT IN EACH MODE

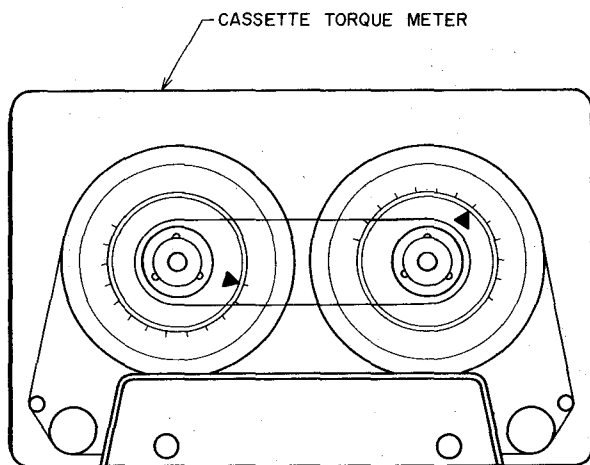

Fig. 5-2

Insert cassette torque meter (AJ-751179) and measure in each mode.

PLAY mode

Take up Torque: 35 to 75 gm-cm

Back tension torque: 1 to 6 gm-cm

FAST FORWARD, REWIND mode

Take up Torque: 80 to 140 gm-cm

5-3. TAPE SPEED ADJUSTMENT

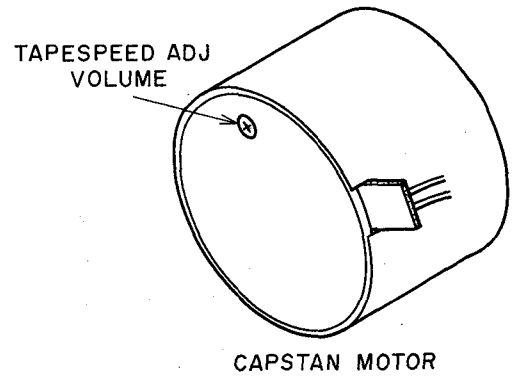

Fig. 5-3

Connect a frequency Counter to Line output terminals. Play Back a 3,150Hz Tape Speed Test Tape (AT-751263) and adjust a Tape Speed Adjustment Volume (see Fig. 5-3) to obtain a tape speed of $3,150 \pm 30$ Hz.

5-4. REC/PB HEAD AZIMUTH ADJUSTMENT

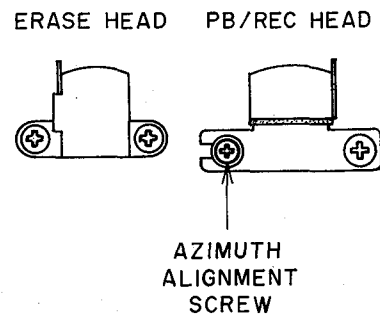

Fig. 5-4

Play back a 10kHz Azimuth Alignment tape (AT-750778) and adjust the Azimuth Alignment Screw, until the output levels of both channels are maximum. After Adjustment, Paintlock the azimuth Alignment Screw.

VI. ELECTRICAL ADJUSTMENT

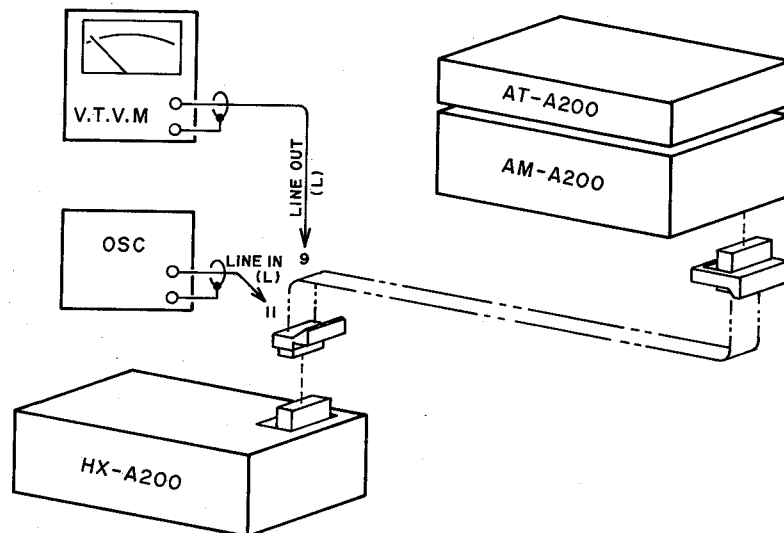
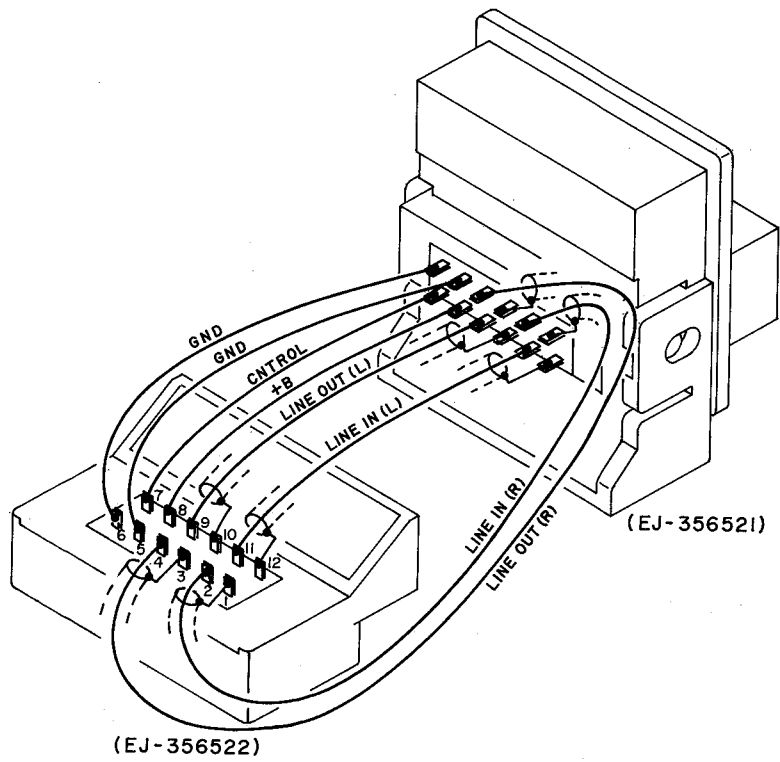

Fig. 6-1 Connection

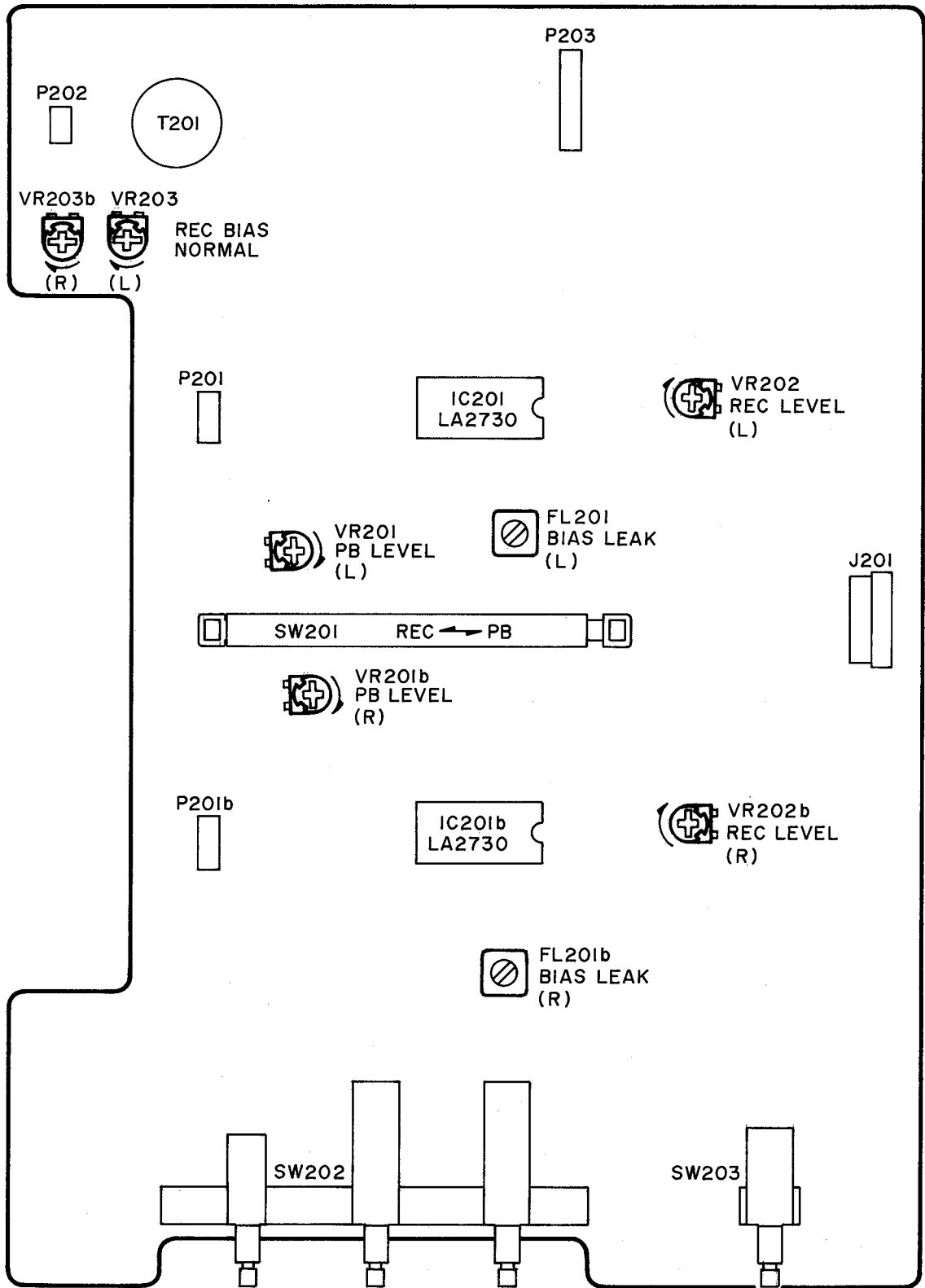

Fig. 6-2 Pre Amp PCB (Parts Side View)

Step	Adjustment Item	Input Signal or Test Tape	Mode	Adjustment Parts	Result	Remarks
1	PB LEVEL	315Hz	PB	VR201	-19.7±0.2dB	
2	NORMAL POSITION FREQUENCY RESPONSE	NORMAL Blank Tape 1kHz, 10kHz -39.7dBm	REC/ PB	VR203	1kHz, 10kHz -39.7±0.3dBm	
3	REC LEVEL	NORMAL Blank Tape 315Hz, -19.7dBm	REC/ PB	VR202	-19.7±0.2dBm	

- NOTE: 1. All adjustments are without Dolby.
 2. Use the following cassette measuring tapes:
 NORMAL TAPE : Maxell UDI C-60
 CrO₂ TAPE : TDK SA C-60
 METAL TAPE : TDK MA C-60

VII. PC BOARD TITLES AND IDENTIFICATION NUMBERS

PC BOARD TITLE	PC BOARD NUMBER	REMARKS
PRE AMP PC BOARD	T2085B501A	
STANDBY SW PC BOARD	T2085B501B	
CONNECTOR PC BOARD	T2085B501C	
LED PC BOARD	T2085B501D	
LEVEL METER PC BOARD	T2085B5020	

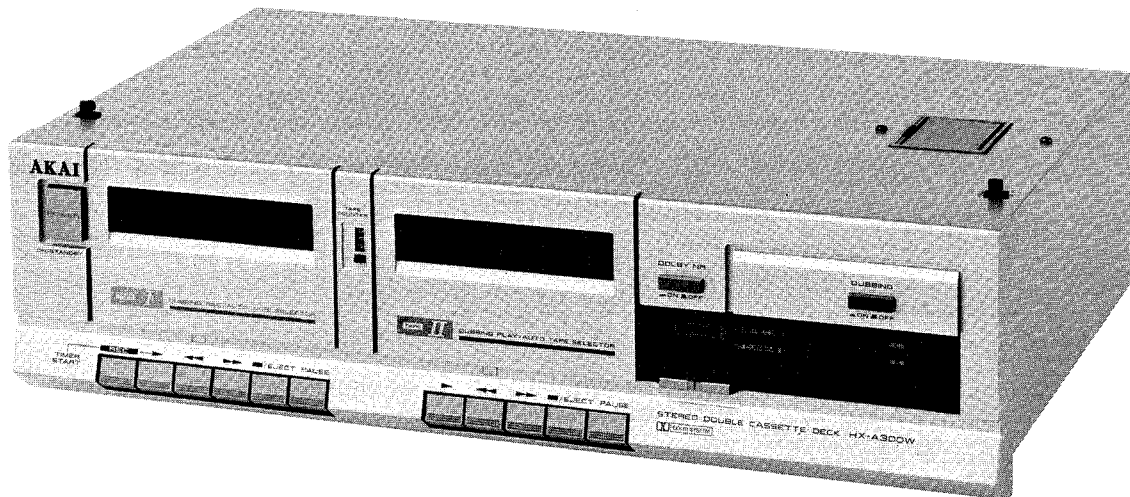

SECTION 6

SERVICE MANUAL

MODEL HX-A300W

TABLE OF CONTENTS

I. SPECIFICATIONS	36
II. DISMANTLING OF UNIT	36
III. CONTROLS	37
IV. PRINCIPAL PARTS LOCATION	37
V. MECHANICAL ADJUSTMENT	38
1. PINCH ROLLER PRESSURE MEASUREMENT	38
2. WINDING TORQUE MEASUREMENT IN EACH MODE	38
3. REC/PB HEAD AZIMUTH ADJUSTMENT	38
4. TAPE SPEED ADJUSTMENT	39
VI. ELECTRICAL ADJUSTMENT	39
VII. PC BOARD TITLES AND IDENTIFICATION NUMBERS	41

For basic adjustments, measuring methods, and operating principles, refer to GENERAL TECHNICAL MANUAL.

I. SPECIFICATIONS

TRACK SYSTEM	4 track 2 channel stereo
TAPE	Phillips type cassette
HEADS	Tape I HD head for recording and playback x1 Erase head x1 Tape II HD head for playback
MOTORS	Tape I Electronically speed controlled DC motor x1 Tape II Electronically speed controlled DC motor x1
WOW & FLUTTER	0.05% WRMS (JIS), 0.12% (DIN)
FREQUENCY RESPONSE	Normal 30Hz to 15,000Hz ±3dB CrO ₂ 30Hz to 16,000Hz ±3dB
S/N	56dB Dolby NR switch ON: Improves up to 5dB at 1kHz, 10dB above 5kHz
HARMONIC DISTORTION	Less than 0.7%
DIMENSIONS	440(W) × 122(H) × 254(D) mm (17.3 × 4.8 × 10.0 inches)
WEIGHT	3.1kg (6.8lbs)

- * For improvement purposes, specifications and design are subject to change without notice.
- * Noise Reduction manufactured under license from Dolby Laboratories Licensing corporation. "Dolby" and the double-D Symbol are trade marks of Dolby Laboratories Licensing Corporation.

II. DISMANTLING OF UNIT

In case of trouble, etc. necessitating dismantling, please dismantle in the order shown in the photographs. Reassemble in reverse order.

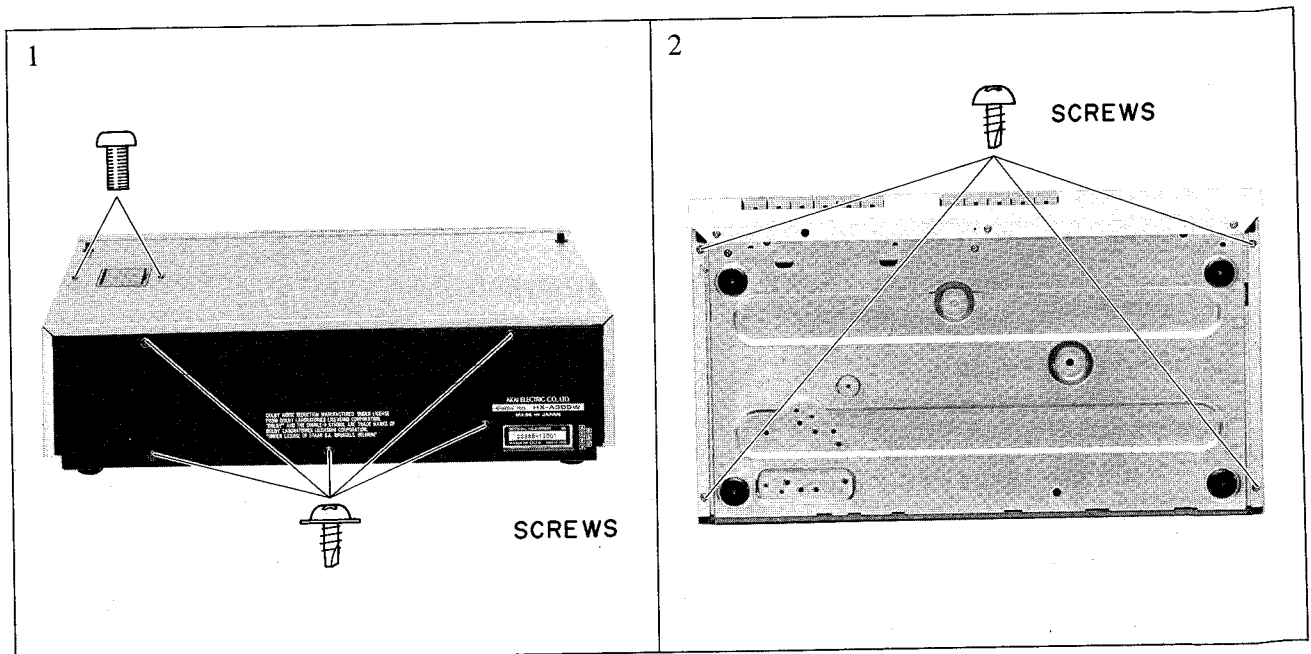

V. MECHANICAL ADJUSTMENT

5-1. PINCH ROLLER PRESSURE MEASUREMENT

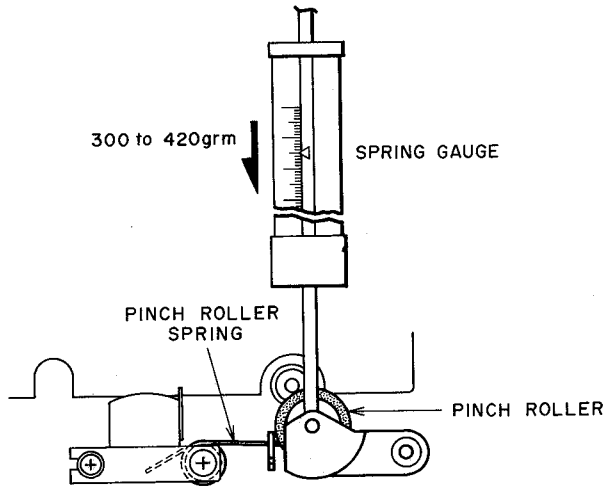

Fig. 5-1

Put in PLAY mode. Push pinch roller arm down with the spring gauge, push the pinch roller 1 to 2 mm from the Capstan and release slowly. Read the spring gauge at the moment the pinch roller touches the capstan and begins to rotate. Specified contact pressure measurement of 300 to 550gram. If there is no measurement obtained, Adjust or Replace the pinch roller spring.

5-2. WINDING TORQUE MEASUREMENT IN EACH MODE

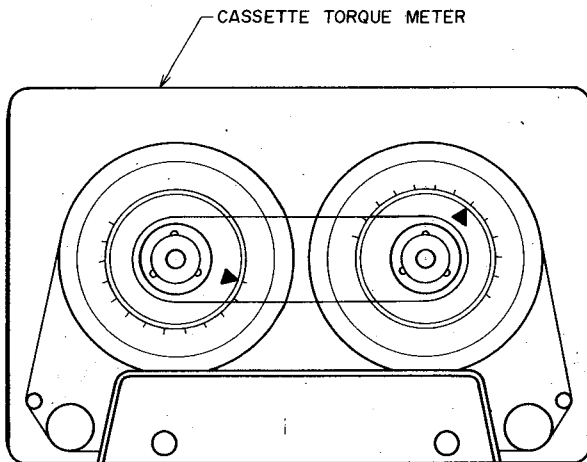

Fig. 5-2

Insert cassette torque meter (AJ-751179) and measure in each mode. For Fast Forward and Rewind, measure at the end of tape when the tape has stopped running.

PLAY Mode

Take up Torque: 35 to 75 gm-cm

Back tension torque: 1 to 6 gm-cm

FAST FORWARD, REWIND mode

Take up Torque: 70 to 160 gm-cm

5-3. REC/PB HEAD AZIMUTH ADJUSTMENT

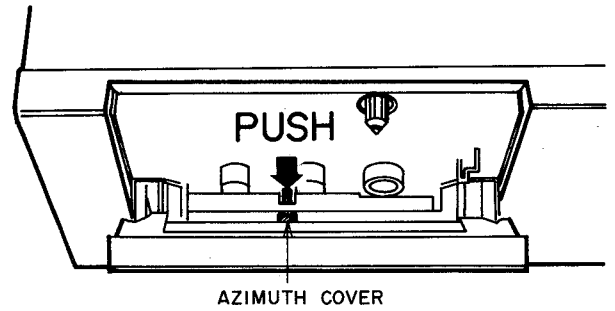

Fig. 5-3

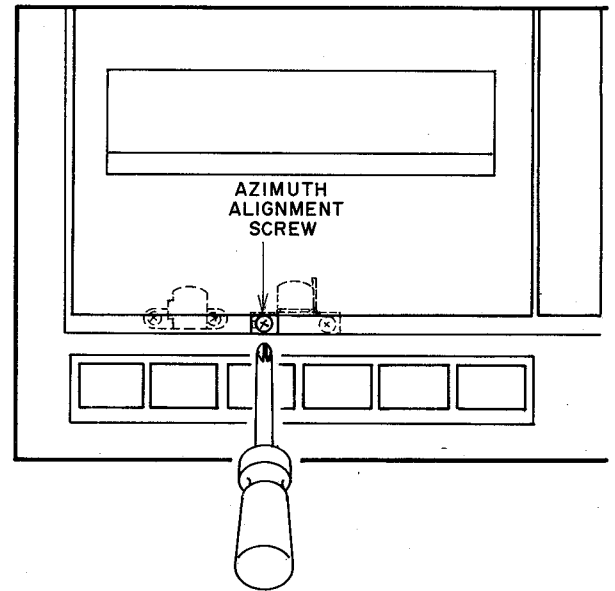

Fig. 5-4

Play Back a 10kHz Azimuth Alignment Tape (AT-750778) and Adjust the Azimuth Alignment Screw, until the output levels of both channels are maximum. After Adjustment, Paintlock the Azimuth Alignment Screw.

5-4. TAPE SPEED ADJUSTMENT

1. Connect a frequency counter to LINE OUT. (Refer to Fig. 4-2)

TAPE I Selection

2. Playback a 3150Hz pre-recorded Test Tape (AT-751263) and adjust a Tape Speed adjustment volume (See Fig. 5-4) to obtain a tape speed of $3150\text{Hz} \pm 30\text{Hz}$.

TAPE II Selection

3. Playback a 3150Hz pre-recorded Test Tape (AT-751263) and adjust a Tape Speed adjustment volume (See Fig. 5-4) to obtain a tape speed of $3150\text{Hz} \pm 30\text{Hz}$.
4. Confirmation that speed deviation toward TAPE I is within $\pm 20\text{Hz}$.

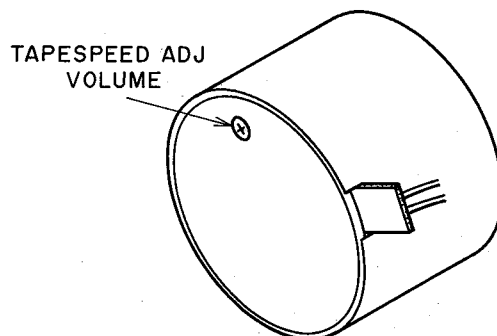

CAPSTAN MOTOR

VI. ELECTRICAL ADJUSTMENT

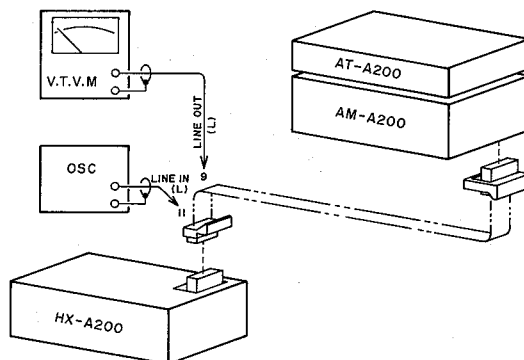
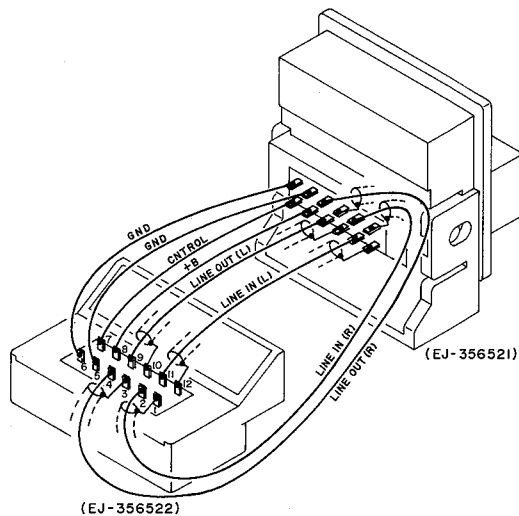

Fig. 6-1 Connection

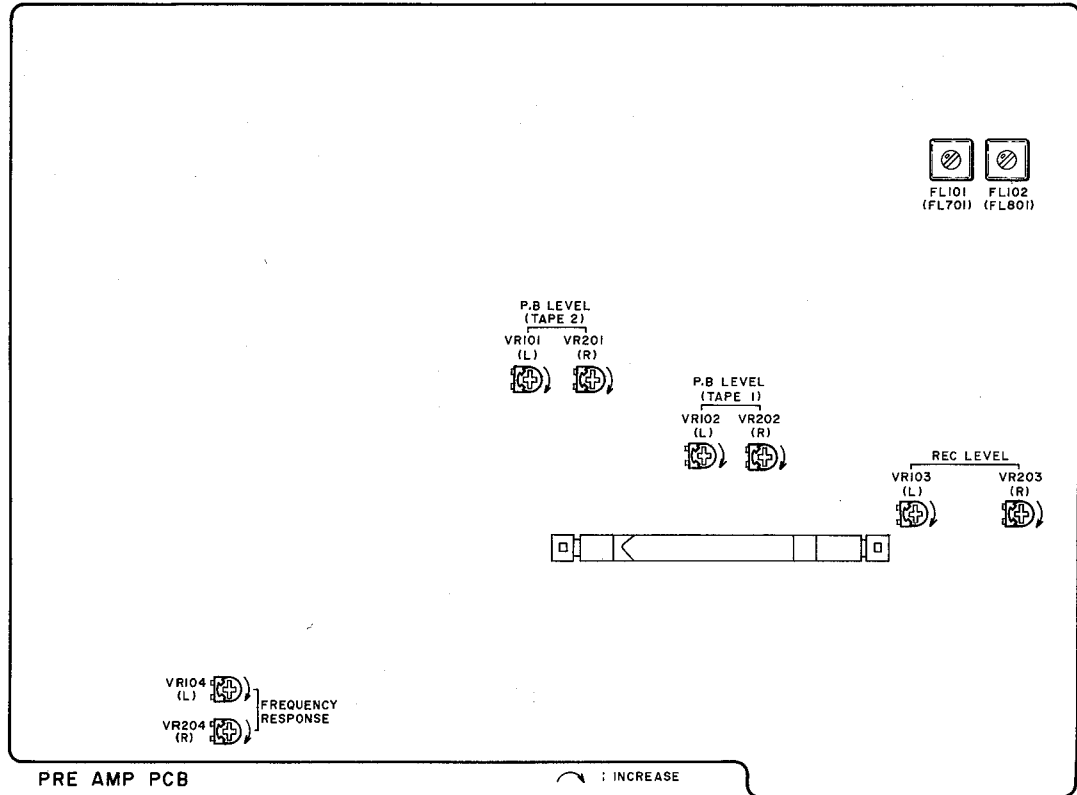

Fig. 6-2

MODEL HX-A300W

Step	Adjustment Item	Test Tape & Supply Signal	Mode	Adjustment Part	Result	Remarks
1	P.B LEVEL (TAPE I)	315Hz	P.B	VR102 (Lch) VR202 (Rch)	-19.7±0.5dBm	
2	P.B LEVEL (TAPE II)	315Hz	P.B	VR101 (Lch) VR201 (Rch)	-19.7±0.5dBm	
3	NORMAL POSITION FREQUENCY RESPONSE	NORMAL BLANK TAPE 1kHz, 10kHz -40.0dBm	REC/ P.B	VR104 (Lch) VR204 (Rch)	1kHz, 10kHz -40.0 0.5dBm	
4	REC LEVEL	NORMAL BLANK TAPE 315Hz -19.7dBm	REC/ P.B	VR103 (Lch) VR203 (Rch)	-19.7±0.5dBm	

- NOTE: 1. All adjustment are without Dolby.
 2. Use the following cassette measuring tapes:
 NORMAL TAPE : Maxell UDI C-60
 CrO₂ TAPE : TDK SA C-60
 METAL TAPE : TDK MA C-60

VII. P.C BOARD TITLE AND IDENTIFICATION NUMBERS

PC BOARD TITLE		PC BOARD NUMBER	REMARKS
PRE AMP	PC BOARD	T2086A501A	
METER	PC BOARD	T2086A501B	
DUBBING SW	PC BOARD	T2086A501C	
CONNECTOR	PC BOARD	T2086A501D	
POWER SW	PC BOARD	T2086A501E	

SECTION 7

PARTS LIST

TABLE OF CONTENTS

I. MODEL AP-A100/C	45	V. MODEL HX-A200	55
1. MOTOR PC BOARD	45	RECOMMENDED SPARE PARTS	55
2. FINAL ASSEMBLY BLOCK	45	1. MECHA BLOCK	56
II. MODEL AP-A200/C	46	2. PC BOARD BLOCK	57
RECOMMENDED SPARE PARTS	46	3. PRE AMP PC BOARD	57
1. MOTOR PC BOARD	46	4. LEVEL METER PC BOARD	57
2. SPEED SELECTOR PC BOARD	46	5. STAND BY SW PC BOARD	57
3. LED PC BOARD	46	6. LED PC BOARD	57
4. FINAL ASSEMBLY BLOCK	46	7. ASSEMBLY BLOCK	58
III. MODEL AT-A200/L	48	8. FINAL ASSEMBLY BLOCK	59
RECOMMENDED SPARE PARTS	48	VI. MODEL HX-A300W	60
1. PC BOARD BLOCK	49	RECOMMENDED SPARE PARTS	60
2. TUNER PC BOARD	49	1. MECHA (REC/PB) BLOCK	61
3. FRONT END PC BOARD	49	2. MECHA (PB) BLOCK	62
4. CONTROL PC BOARD	49	3. PC BOARD BLOCK	63
5. POWER SW PC BOARD	49	4. PRE AMP PC BOARD	63
6. CONNECTOR PC BOARD	49	5. METER PC BOARD	63
7. ASSEMBLY BLOCK	50	6. DUBBING PC BOARD	63
8. FINAL ASSEMBLY BLOCK	50	7. POWER SW PC BOARD	63
IV. MODEL AM-A200	51	8. ASSEMBLY BLOCK	64
RECOMMENDED SPARE PARTS	51	9. FINAL ASSEMBLY BLOCK	65
1. PC BOARD BLOCK	51	INDEX	66
2. PRE AMP PC BOARD	51	1. MODEL AP-A100/C	66
3. GRAPHIC EQ PC BOARD	51	2. MODEL AP-A200/C	66
4. MAIN PC BOARD	52	3. MODEL AT-A200/L	66
5. POWER SUPPLY PC BOARD	52	4. MODEL AM-A200	67
6. LED PC BOARD	52	5. MODEL HX-A200	67
7. VOLUME PC BOARD	52	6. MODEL HX-A300W	68
8. CONNECTOR (A) PC BOARD	52		
9. CONNECTOR (B) PC BOARD	52		
10. ASSEMBLY BLOCK	53		
11. FINAL ASSEMBLY BLOCK	54		

Resistor and Capacitor which is not listed in this parts list, please refer to COMMON LIST FOR SERVICE PARTS.

ATTENTION

1. When placing an order for parts, be sure to list the parts no., model no., and description of each part. If any of this information is omitted, there are instances in which parts cannot be shipped or the wrong parts will be delivered.
2. Please be careful not to make a mistake in the parts no. If the parts no. is in error, a part different from the one ordered may be delivered.
3. Because part numbers and part definitions and supply in the Preliminary Parts List may have been the subject of changes, please use this parts list for all future reference.

HOW TO USE THIS PARTS LIST

1. This Parts List shows those parts which are considered necessary for repairs. Other parts, such as resistors and capacitors, are shown in the "Common List for Service Parts" from which these parts should be selected and parts.
2. The Recommended Spare Parts List shows those parts in the Parts List which are considered particularly important for service.
3. Parts not shown in the Parts List and "Common List for Service Parts" will not in principle be supplied.
4. How to read the parts list

a) Mechanism Block

b) P.C Board Block

2. HEAD BASE BLOCK

REF. NO.	PART NO.	DESCRIPTION
2-1x	BH-T2023A320A	HEAD BASE BLOCK GX-F66R
2-2	HP-H2206A010A	HEAD R/P PR4-8FU C
2-3	ZS-477876	PAN20x03STL CMT
2-4	ZS-536488	BID20x08STL CMT
2-5	ZG-402895	CS ANGLE ADJUST SPRING

- SP (Service Parts) Classification
- A small "x" indicates the inability to show that particular part in the Photo or Illustration.
- This number corresponds with the individual parts index number in that figure
- This number corresponds with the Figure Number

6. SYS. CON. P C BOARD BLOCK

REF. NO.	PART NO.	DESCRIPTION
6-1	BA-T2034A070A	PC SYS CON BLK GX-F44R
6-IC1	EI-324536	IC HD14049BP
6-IC2	EI-336801	IC MB8841-564M
6-IC3	EI-331661	IC SN7405N
6-IC4	EI-336725	IC M54527P
6-TR1to4	ET-200985	TR 2SC2603 F,G
6-TR5to28	ET-554657	TR 2SA733A P,Q
6-D1	ED-318292	D SILICON H 1S2473T-77 T26
6-D2to4	ED-308952	D GERMA V 1K34A-LR F07
6-D5to10	ED-318292	D SILICON H 1S2473T-77 T26
6-X1	EI-318384	OSC X'TAL NC-18C 3.579545MHZ

- SP (Service Parts) Classification
- These reference symbols correspond with component symbols in the Schematic Diagrams.

5. The kind of part and its installation position can both be determined by the Part Number. To determine where a part number is listed, utilize the Parts Index at the end of the Parts List. It is necessary first of all to find the Part Number. This can be accomplished by using the Reference Number listed at the right of the part number in the Parts Index.

WARNING

⚠ INDICATES SAFETY CRITICAL COMPONENTS. FOR CONTINUED SAFETY, REPLACE SAFETY CRITICAL COMPONENTS ONLY WITH MANUFACTURE'S RECOMMENDED PARTS

AVERTISSEMENT

⚠ IL INDIQUE LES COMPOSANTS CRITIQUES DE SÉCURITÉ. POUR MAINTENIR LE DEGRÉ DE SÉCURITÉ DE L'APPAREIL, NE REMPLACER QUE DES PIÈCES RECOMMANDÉES PAR LE FABRICANT

I. MODEL AP-100

FINAL ASSEMBLY BLOCK

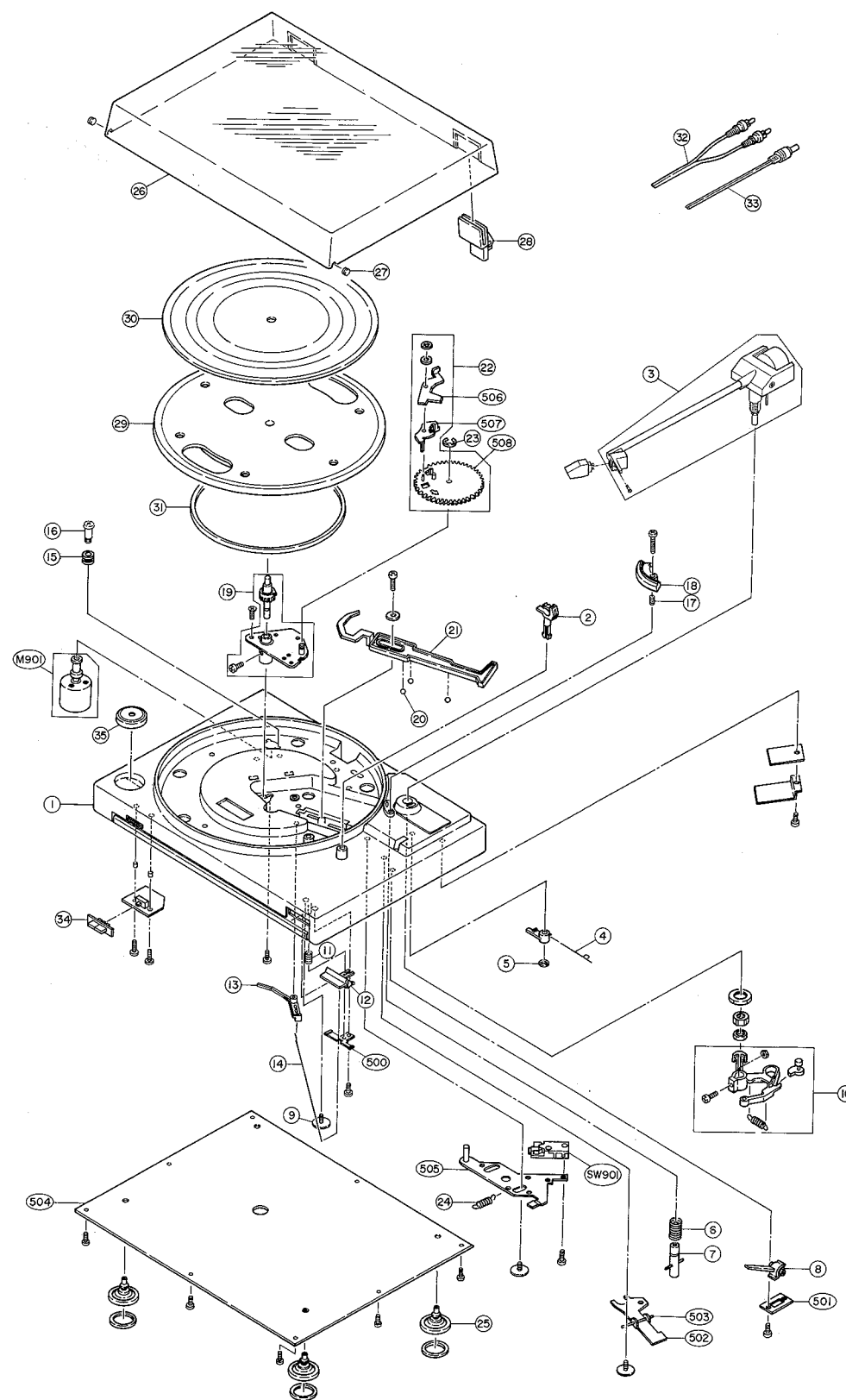

NOTE: Parts listed in 1 to SW901 on the exploded view and list are normally stocked for replacement purpose. The remaining parts shown in this manual are not normally stocked, because they are seldom required for routine service.

Optional Accessory
Cartridge PC-35

1. MOTOR PC BOARD

REF. NO.	PART NO.	DESCRIPTION
1-IC1	EI-357879	IC LA5512
1-SW1	ES-358768	SW SLIDE S5Y322-059
1-VR1,VR2	EV-315416	R S-FIX H D8 3P 103

SYMBOL FOR DESTINATION

[A]: AAL (USA)
[B]: UK (England)

2. FINAL ASSEMBLY BLOCK

REF. NO.	PART NO.	DESCRIPTION
2-1	BC-358036A	CABINET AP-A100
2-1B	BC-358036B	CABINET AP-A100-B
2-2	TP-358836	CLAMPER ARM
2-3	TP-351625	TONE ARM ARM-A1
2-4	ZG-353257	SP TORSION CANCELER
2-5	ZW-340648	RING CS 190STL PKR
2-6	ZG-325402	SP ELEVATION
2-7	TP-345341	SHAFT ELEVATION
2-8	SK-345362A	KNOB ELEVATION
2-8B	SK-345362E	KNOB ELEVATION-B
2-9	ZS-358930	SCREW B Y 3824
2-10	TP-P1034A040A	PU PLATE BLK AP-B1
2-11	ZG-313181	SP C-04.5/0.35-16.0 C-028
2-12	SK-351739	KNOB CUT
2-13	ML-358006	LEVER MANUAL
2-14	MZ-358034	WIRE CUT
2-15	MB-345351B	CUSHION RUBBER (2)
2-16	ZS-350767	SCREW
2-17	ZG-332548	SP PUSH (A)
2-18	TP-B332568X2	ARM ELEVATION PART
2-19	TP-B345367	CHASSIS SPINDLE PART
2-20	MV-269965	BALL 400STL
2-21	ML-345348	LEVER AUTO
2-22	TP-P1034A080A	GEAR MAIN BLK AP-B1
2-23	ZW-270101	RING E 300SUP CMT
2-24	ZG-313073	SP T1-06.3/0.50-28.0 T1-18510
2-25	SA-332577C	INSULATOR (C)
2-26	BC-B332582	DUST COVER PART
2-27	TP-301300	COVER CUSHION
2-28	TP-336361	HINGE AUTO OH-5
2-28B	TP-336362	HINGE AUTO OH-5-BL
2-29	TP-348321	PLATTER
2-30A	TP-348266A	TABLE SHEET A [U,B]
2-30B	TP-348266B	TABLE SHEET B [A]
2-31	MB-355119	BELT EP
2-32A	EW-358749	CORD 2P AUDIO CORD [U,B]
2-32B	EW-358750	CORD 2P AUDIO UL [A]
2-33	EW-358754	CORD 2CORES DC CORD UL
2-34	SK-351613B	KNOB SLIDE-B
2-35	AX-332567C	45 ADAPTER-S
2-35B	AX-332567D	45 ADAPTOR-B
2-M901	BM-354988	MOTOR BFD2R16
2-SW901	ES-316432	SW MICRO K2(P)

SYMBOL FOR COLOR VARIATION

NON : STANDARD-COLOR
B OR BL : BLACK

II. MODEL AP- A200

RECOMMENDED SPARE PARTS

Because, if the parts listed below are on hand, almost any repair can be accomplished, we suggest that you stock these Recommended Spare Parts Items.

REF. NO.	PART NO.	DESCRIPTION
1 N	BM-360085	△ MOTOR SS09DA
2	ED-349656	D LED AY5505S
3	ED-337391	D LED GL5NG6 GREEN
4	ED-557447	D SILICON H 1S1588
5	ED-708712	D SILICON 1S1555
6	EI-780137	IC VC1031
7	ES-325488	SW MICRO K1(P)
8	ES-337843	SW PUSH ESB-64501 02-2
9	ET-308867	TR 2SA1015 O,Y,GR
10	ET-742510	TR 2SA950 O,Y
11	ET-330225	TR 2SC1815 BL
12	ET-328844	TR 2SC3120 O,Y
13	EV-780138	R S-FIX 103
14	TP-P1034A080A	MAIN GEAR BLK AP-B1

"NOTE" N: New Parts
 SYMBOL FOR DESTINATION
 [A]: AAL (USA)
 [B]: UK (England)
 [U]: U/T (Universal Area)

1. MOTOR PC BOARD

REF. NO.	PART NO.	DESCRIPTION
1-IC1	EI-780137	IC VC1031
1-Q1,Q2	ET-328844	TR 2SC2110 O,Y
1-Q3,Q4	ET-742510	TR 2SA950 O,Y
1-Q5,Q6	ET-308867	TR 2SA1015 O,Y,GR
1-Q7,Q8	ET-330225	TR 2SC1815 BL
1-Q9	ET-308867	TR 2SA1015 O,Y,GR
1-Q10	ET-330225	TR 2SC1815 BL
1-Q11	ET-742510	TR 2SA950 O,Y
1-D1	ED-708712	D SILICON 1S1555
1-VR1	EV-780138	R S-FIX 103
1-R1	ER-353877	△ R OMF H S15 FS 1W 1R0J

2. SPEED SELECTOR PC BOARD

REF. NO.	PART NO.	DESCRIPTION
2-D1,D2	ED-557447	D SILICON H 1S1588
2-SW1	ES-337843	SW PUSH ESB-64501 02-2

3. LED PC BOARD

REF. NO.	PART NO.	DESCRIPTION
3-D1	ED-337391	D LED GL5NG6 GREEN
3-D2	ED-349656	D LED AY5505S

4. FINAL ASSEMBLY BLOCK

REF. NO.	PART NO.	DESCRIPTION
4-1	BC-353231D	CABINET (2)
4-1B	BC-353231F	CABINET (2)-B
4-2	TP-358836	C LAMPER ARM
4-3	ZG-358951	SP ELEVATION
4-4	MS-353238	SHAFT ELEVATION
4-5	ZG-353257	SP TORSION CANCELER
4-6	ZW-340648	RING CS 190STL PKR
4-7	TP-353252	TONE ARM ARM-A2
4-8	ZW-325521	N120x170x30STL CMT P100
4-9	TP-P1037A040A	LEVER PU PLATE BLK AP-A2
4-10	ZS-358930	SCREW B Y 3824
4-11	ZW-340648	RING CS 190STL PKR
4-12	ZS-310984	PT BR30x08STL CMT
4-13	ZG-358000	SP TORSION KNOB
4-14	ZW-331536	PW21x050x013PSL
4-15	ZW-382083	WASHER (NYLON) D6.1x13x1T
4-16	TP-358003	WIRE ELEVATION
4-17	ML-358006	LEVER MANUAL
4-18	TP-353712	HINGE ASSY AP-A2
4-19	ZS-349118	S CREW W/FRANGE
4-20	ZG-332548	SP PUSH (A)
4-21	TP-B332568X2	ARM ELEVATION PART
4-22	TP-360072	LEVER REJECT (B)
4-23	MV-269965	BALL 400STL
4-24	ML-345348	LEVER AUTO
4-25	TP-P1034A080A	MAIN GEAR BLK AP-B1
4-26	ZW-290283	RING U 285SUP CMT
4-27	ZG-313073	SP T1-06.3/0.50-28.0 T1-185
4-28	SA-332577	INSULATOR
4-29	TP-358012A	ANGLE LIFTER
4-29B	TP-358012B	ANGLE LIFTER-B
4-30xA	AX-332567C	45 ADAPTER-S
4-30xB	AX-332567D	45 ADAPTER-B
4-31	BD-P1047A020A	PANEL FRONT BLK AP-A200-C
4-31B	BD-P1047A020B	PANEL FRONT BLK AP-A200-CB
4-32	SK-358010A	KNOB CUT
4-32B	SK-358010B	KNOB CUT-B
4-33	SK-358011A	KNOB SPEED
4-33B	SK-358011B	KNOB SPEED-B
4-34	ZG-358952	SP KNOB (B)
4-35	SP-359109	SP KNOB (C)
4-36	ZS-332009	PT BR30x06STL CMT [PANEL FRONT FIX]
4-37	BC-B353247	DUST COVER PART
4-38	MB-343057	COVER CUSHION
4-39	TP-B358014	PLATTER PART
4-40A	TP-348266B	TABLE SHEET B [A]
4-40B	TP-348266A	TABLE SHEET A [U,B]
4-41	EW-358754	CORD 2CORES DC CORD UL
4-42A	EW-358750	CORD 2P AUDIO UL [A]
4-42B	EW-358749	CORD 2P AUDIO CORD [U,B]
4-M901	BM-360085	△ MOTOR SS09DA
4-SW901	ES-325488	SW MICRO K1(P)

NOTE: Parts listed in 1 to SW901 on the exploded view and list are normally stocked for replacement purpose. The remaining parts shown in this manual are not normally stocked, because they are seldom required for routine service.

Optional Accessory
 Cartridge PC-35

FINAL ASSEMBLY BLOCK

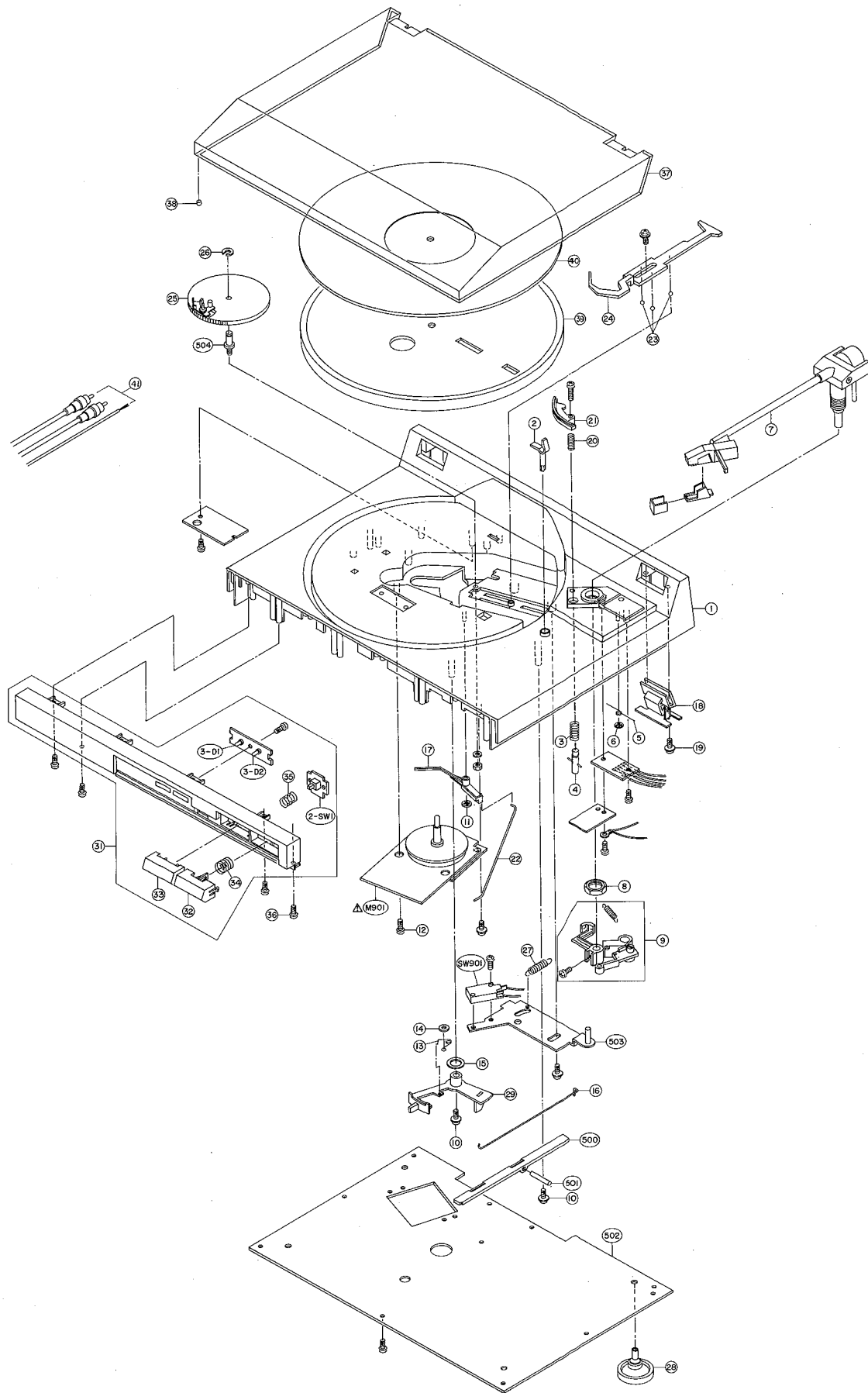

PARTS LIST

III. MODEL AT-A200/L

RECOMMENDED SPARE PARTS

Because, if the parts listed below are on hand, almost any repair can be accomplished, we suggest that you stock these Recommended Spare Parts Items.

REF. NO.	PART NO.	DESCRIPTION
1 N	EC-359065	CS-FIX H CTC-6U-020 4.3-20
2	ED-321269	D LED GL5PR6 RED
3	ED-301911	D SILICON H DS448
4	ED-344280	D SILICON H GMA-01-FY2 F05
5	ED-349460	D VARACTER SVC321 A,B,C,D DOUBLE
6	ED-349448	D VARACTOR 1SV147
7	ED-306316	D ZENER H HZ5 C2
8	ED-337265	D ZENER H HZ6 C2
9	EH-336804	FILTER CE S FE10.7MA8 10.7MHZ
10	EH-355568	FILTER CE S FE 10.7MS2GY-A
11 N	EH-355382	FILTER LC BP 79-5151-11 [V]
12 N	EI-359048	IC C1005-736
13	EI-354951	IC LM7000
14 N	EI-359060	IC HA12430
15 N	EI-359061	IC LA3361
16	EI-348409	OSC CE CSB400P 0.4MHZ
17	EI-344422	OSC X'TAL HC-18/U 7.200000MHZ
18	EM-353670	IND FL 8-BT-29ZK CHARACTER
19	EO-337598	COIL VARI 2 25A-1353-01
20	EO-337599	COIL VARI 2 25A-1354-03 [L]
21 N	ES-360115	SW SLIDE 00120262 01-02S [U,Y1]
22	ES-344445	SW TACT EVQ-QHR12B
23	ES-349367	SW TACT SKHHAB044A
24 N	ES-359172	SW TACT SKHHAF
25	ET-351853	TR FET 2SK161 Y
26	ET-352408	TR FET 2SK192A GR [L]
27	ET-337759	TR FET 2SK246 GR
28	ET-353899	TR 2SA1317 S,T,U
29	ET-338410	TR 2SC2878 A,B [L]
30	ET-336869	TR 2SC2999 C,D
31	ET-353366	TR 2SC3112 A,B
32	ET-353898	TR 2SC3330
33	ET-349081	TR 2SC3383 S,T
34	ET-328265	TR 2SC930 F
35	EV-356579	R S-FIX H H0615C 3P 102
36	EV-356577	R S-FIX H H0615C 3P 103

"NOTE" N: New Parts

SYMBOL FOR DESTINATION

- [A]: AAL (USA)
- [B]: UK (England)
- [C]: CSA (Canada)
- [E]: CEE (Europe)
- [S]: SAA (Australia)
- [U]: U/T (Universal Area)
- [V]: VDE (West Germany)

1. PC BOARD BLOCK

REF. NO.	PART NO.	DESCRIPTION
1-1A	BA-A3052A030A	PC TUNER BLK AT-A200(U)
1-1B	BA-A3052A030B	PC TUNER BLK AT-A200(C)
1-1C	BA-A3052A030C	PC TUNER BLK AT-A200(E)
1-1D	BA-A3052A030D	PC TUNER BLK AT-A200(V)
1-1E	BA-A3052A030E	PC TUNER BLK AT-A200(S)
1-1F	BA-A3052A030F	PC CONTROL BLK AT-A200L (E,B)
1-1G	BA-A3052A030G	PC TUNER BLK AT-A200 (Y1)
1-2A	BA-F0141A010A	PC FRONT END BLK FE41 (U,C,A, E,S,L)
1-2B	BA-F0141A010B	PC FRONT END BLK FE41 (V)
1-2C	BA-F0141A010C	PC FRONT END BLK FE41/SA (Y1)
1-2	BA-C1005A030A	PC FRONT BLK AC-A100
1-3A	BA-A3052A020A	PC CONTROL BLK AT-A200(U)
1-3B	BA-A3052A020B	PC CONTROL BLK AT-A200(C)
1-3C	BA-A3052A020C	PC CONTROL BLK AT-A200(A)
1-3D	BA-A3052A020D	PC CONTROL BLK AT-A200(E,V,S)
1-3E	BA-A3052A020E	PC CONTROL BLK AT-A200L (E,B)
1-3F	BA-A3052A020F	PC CONTROL BLK AT-A200 (Y1)

NOTES:

- (1) PC TUNER BLK consists of following PC BOARDS.
 - TUNER PC BOARD
 - FRONT END PC BOARD
 - CONNECTOR PC BOARD
- (2) PC CONTROL BLK consists of following PC BOARDS.
 - CONTROL PC BOARD
 - POWER SW PC BOARD

2. TUNER PC BOARD

REF. NO.	PART NO.	DESCRIPTION
2-IC1	EI-354951	IC LM7000
2-IC2	EI-359060	IC HA12430
2-IC3	EI-359061	IC LA3361
2-TR1	ET-328265	TR 2SC930 F
2-TR2	ET-337759	TR FET 2SK246 GR
2-TR3	ET-349081	TR 2SC3383 S,T
2-TR4	ET-338410	TR 2SC2878 A,B [L]
2-TR5	ET-352408	TR FET 2SK192A GR [L]
2-TR6	ET-338410	TR 2SC2878 A,B [L]
2-TR7	ET-353898	TR 2SC3330 [L]
2-TR8,TR9	ET-353899	TR 2SA1317 S,T,U
2-TR10	ET-353898	TR 2SC3330
2-TR11	ET-351853	TR FET 2SK161 Y
2-TR12	ET-328265	TR 2SC930 F
2-TR13	ET-351853	TR FET 2SK161 Y
2-TR14	ET-353898	TR 2SC3330
2-TR15,		
TR16	ET-353366	TR 2SC3112 A,B
2-TR17 to		
TR21	ET-349081	TR 2SC3383 S,T
2-TR22,		
TR23	ET-353898	TR 2SC3330 [L]
2-D1	ED-306316	D ZENER H HZ5 C2
2-D2,D3	ED-349460	D VARACTER SVC321 A,B,C,D DOUBLE
2-D4,D5	ED-344280	D SILICON H GMA-01-FY2 F05 [L]
2-D6	ED-344280	D SILICON H GMA-01-FY2 F05
2-D7	ED-337265	D ZENER H HZ6 C2
2-D8 to D10	ED-301911	D SILICON H DS448
2-D11	ED-344280	D SILICON H GMA-01-FY2 F05
2-SW1	ES-344445	SW TACT EVQ-QHR12B
2-SW2	ES-360115	SW SLIDE 00120262 01-02S [U,Y1]
2-VR1	EV-356577	R S-FIX H H0615C 3P 103
2-VR2	EV-356579	R S-FIX H H0615C 3P 102
2-FL1,FL2	EH-355568	FILTER CE SFE10.7MS2GY-A
2-FL3	EH-336804	FILTER CE SFE10.7MA8 10.7MHZ
2-FL4	EH-355382	FILTER LC BP 79-5151-11 [V]
2-L1,L2	EO-337523	COIL FIX 1 L-8 223J
2-T1	EO-337598	COIL VARI 1 25A-1353-01
2-T2	EO-337599	COIL VARI 2 25A-1354-03 [L]
2-T3	EO-336829	COIL OSC 2 7NR-7818F 125UH
2-T4	EO-359062	COIL OSC2 7BR-9585F [L]
2-T5	EO-359063	COIL DET2 117-1009-01
2-T6	EO-356732	COIL IFT BCFLZ-450A
2-X1	EI-344422	OSC X'TAL HC-18/U 7.200000MHZ
2-VC1	EC-359065	CS-FIX H CTC-6U-020 4.3-20
2-VC2	EC-359065	CS-FIX H CTC-6U-020 4.3-20 [L]
2-R6	ER-306805	R CB H S15 FS RDS 1/2W 101J
2-R7	ER-327710	R CB H S10 FS RDS 1/4W 151J
2-R8	ER-360146	R OMF H S10 FS 1/2W 151J
2-R47	ER-360146	R OMF H S10 FS 1/2W 151J
2-R64	ER-328067	R CB H S10 FS RDS 1/4W 331J
2-C7	EC-347591	C MMY V F05 MMH63 474M 100DC
2-C17A	EC-356597	C PP V F05 PP 431J 50DC [EXCEPT L]
2-C17B	EC-353044	C PP V F05 PP 511J 50DC [L]
2-C18	EC-346879	C PP V F05 PP 221J 50DC [L]
2-C51	EC-344483	C PP V F05 PP 102J 50DC
2-C62,C63	EC-356598	C PP V F05 PP 302J 50DC
2-TM1	EJ-359031	TERMINAL LEVER YK-D31-0215 P 2P

3. FRONT END PC BOARD

REF. NO.	PART NO.	DESCRIPTION
3-TR1	ET-351853	TR FET 2SK161 Y
3-TR2	ET-336869	TR 2SC2999 C,D
3-TR3	ET-328265	TR 2SC930 F
3-TR4	ET-351853	TR FET 2SK161 Y
3-D1 to D4	ED-349448	D VARACTOR 1SV147
3-L1	EO-349461	COIL FIX 2 LINK
3-L2	EO-349462	COIL FIX 2 U147
3-L3	EO-349461	COIL FIX 2 LINK
3-L4,L5	EO-349462	COIL FIX 2 U147
3-L6	EO-359056	COIL FIX 1 LAL03NA 2R2M
3-L7A	EO-353687	COIL OSC 2 E525HN-110003 [EXCEPT Y1]
3-L7B	EO-361840	COIL OSC 2 E525HNS-110011 [Y1]
3-T1	EO-337640	COIL IFT 119AC-15533X 10.7MHZ

4. CONTROL PC BOARD

REF. NO.	PART NO.	DESCRIPTION
4-IC1	EI-359048	IC C1005-736
4-TR1	ET-353899	TR 2SA1317 S,T,U [U,Y1]
4-D1	ED-301911	D SILICON H DS448 [U,Y1]
4-D2	ED-301911	D SILICON H DS448 [L]
4-D3	ED-301911	D SILICON H DS448 [Y1]
4-D4	ED-301911	D SILICON H DS448 [C,A]
4-D5 to D7	ED-301911	D SILICON H DS448
4-D8	ED-344280	D SILICON H GMA-01-FY2 F05
4-D9,D10	ED-301911	D SILICON H DS448
4-D11	ED-344280	D SILICON H GMA-01-FY2 F05
4-D12,D13	ED-301911	D SILICON H DS448
4-D14	ED-301911	D SILICON H DS448 [A]
4-D15	ED-321269	D LED GL5PR6 RED
4-SW1 to		
SW10	ES-349367	SW TACT SKHHA044A
4-X1	EI-348409	OSC CE CSB400P 0.4MHZ
4-IB1	EH-359049	COMP R TNC15A104J
4-IN1	EM-353670	IND FL 8-BT-292K CHARACTER

5. POWER SW PC BOARD

REF. NO.	PART NO.	DESCRIPTION
5-SW11	ES-359172	SW TACT SKHHA F

6. CONNECTOR PC BOARD

REF. NO.	PART NO.	DESCRIPTION
6-P1	EJ-356522	PLUG CONNECTOR-B M1690-A 12P

ASSEMBLY BLOCK

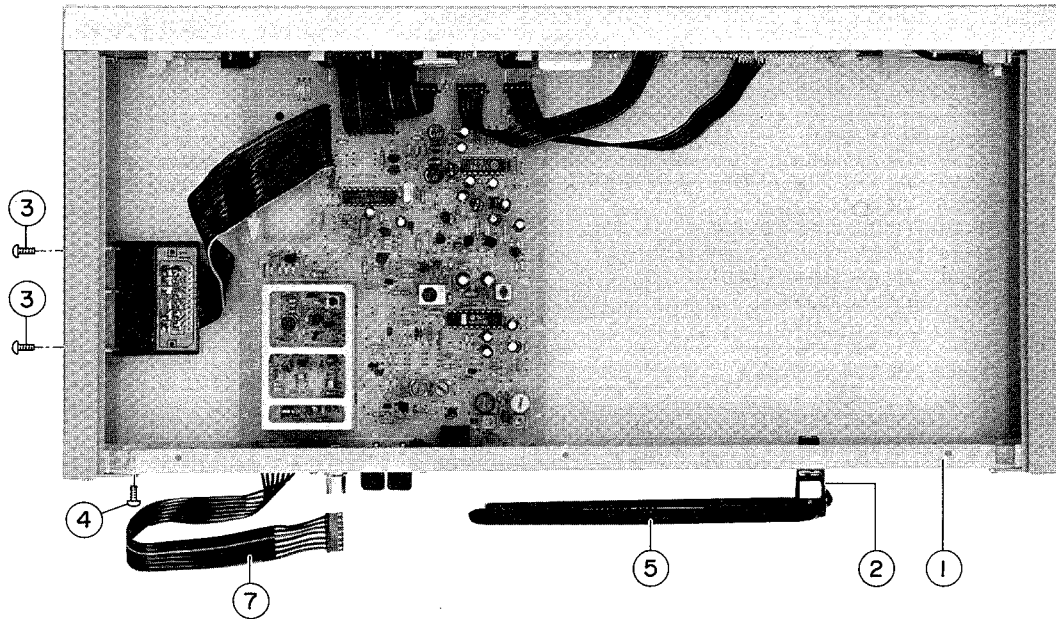

FINAL ASSEMBLY BLOCK

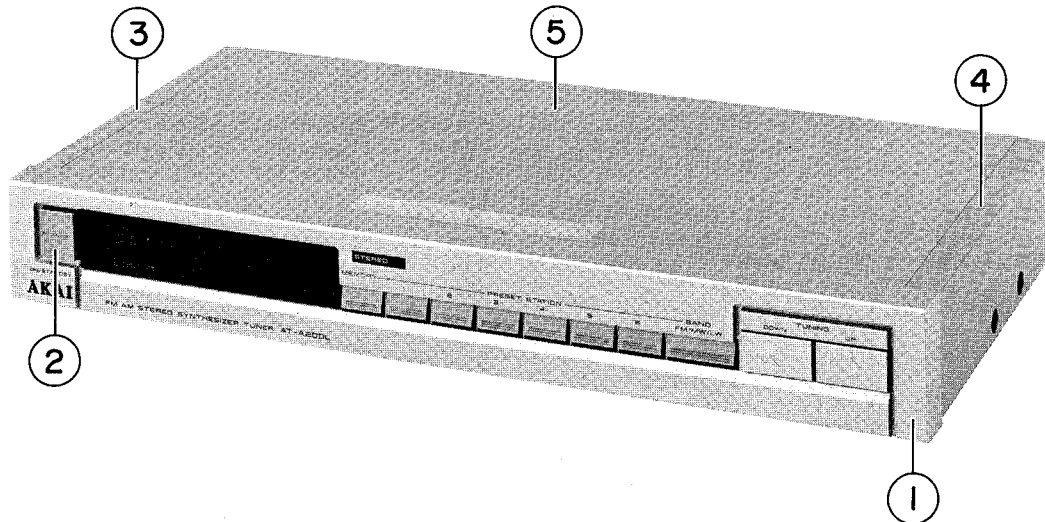

7. ASSEMBLY BLOCK

REF. NO.	PART NO.	DESCRIPTION
7-1A	SP-358980A	PANEL REAR AT-A200(U,Y1)
7-1B	SP-358980B	PANEL REAR AT-A200(A,C,E,S,V)
7-1C	SP-358980E	PANEL REAR AT-A200L(E,B)
7-2	SZ-332739	HOLDER ANTENNA
7-3	ZS-359179	PT BR30x12STL BNI C
7-4	ZS-359226	T2BR 30x10STL BZN
7-5	EE-359265	ANT LOOP LA-200A-A
7-6x	EJ-352118	SOCKET COAX PAL B2-714P-900
7-7	EW-359171	WIRE ASSY AT-A200 7P(T-A)

8. FINAL ASSEMBLY BLOCK

REF. NO.	PART NO.	DESCRIPTION
PANEL FRONT BLOCK		
8-1A	BD-A3052A050A	PANEL FRONT BLK AT-200
8-1B	BD-A3052A050B	PANEL FRONT BLK AT-A200L
8-1C	BD-A3052A050C	PANEL FRONT BLK AT-A200-B [BL]
8-1D	BD-A3052A050D	PANEL FRONT BLK AT-A200L-B [BL]
8-2	SK-343017C	KNOB POWER (2)
8-2B	SK-343017F	KNOB POWER-B
FINAL ASSEMBLY BLOCK		
8-3	BD-358978A	PANEL SIDE(L)
8-3B	BD-358978B	PANEL SIDE (L)-B
8-4	BD-358979A	PANEL SIDE(R)
8-4B	BD-358979B	PANEL FRONT (R)-B
8-5	BC-358993A	COVER T-1
8-5B	BC-358993G	COVER T-1B

SYMBOL FOR COLOR VARIATION
 NON : STANDARD COLOR
 B or BL : BLACK

IV. MODEL AM-A200

RECOMMENDED SPARE PARTS

Because, if the parts listed below are on hand, almost any repair can be accomplished, we suggest that you stock these Recommended Spare Parts Items.

REF. NO.	PART NO.	DESCRIPTION
1 N	BT-359195	△ TRANS POWER A2043T-20 (A)
2 N	BT-359194	△ TRANS POWER A2043T-30 (C)
3 N	BT-359197	△ TRANS POWER A2043T-50 (B,S)
4 N	BT-359193	△ TRANS PWWER A2043T-70 (U)
5 N	BT-359196	△ TRANS POWER JA2043T-40 (E,V)
6	ED-348200	△ D SILICON DBA20C-K15 200/2.0A
7	ED-200213	△ D SILICON DBA40C-K15 200/2.6A
8	ED-346616	△ D ZENER H HZ12 B3
9	ED-346617	△ D ZENER H HZ12 C2
10	ED-337391	D LED GL5NG6 GREEN
11	ED-357754	D SILICON DS135D 200/1.0A
12	ED-301911	D SILICON H DS448
13	ED-319176	D ZENER H HZ12 A3
14	ED-322046	D ZENER H HZ18 1
15	ED-329056	D ZENER H HZ22 2
16	ED-302269	D ZENER H HZ5 A2
17	ED-346603	D ZENER H HZ6 A1
18	ED-337265	D ZENER H HZ6 C2
19 N	EF-359007	△ FUSE BET T 1.25A 250V [B]
20	EF-359225	△ FUSE BET T 3.15A 250V [B]
21 N	EF-359086	△ FUSE BET T 4.00A 250V [B]
22	EF-602550	△ FUSE SEMKO T 1.25A 250V [E,V,S]
23	EF-690996	△ FUSE SEMKO T 250V 4.00A [E,V,S]
24	EF-691007	△ FUSE SEMKO T 3.15A 250V [E,V,S]
25	EF-311839	△ FUSE TSC A 250V 1.60A [U]
26	EF-306952	△ FUSE TSC A 250V 4.00A [U]
27	EF-308847	△ FUSE TSC 125V 1.60A [C,A]
28	EF-323080	△ FUSE TSC 125V 3.15A [C,A]
29	EF-306957	△ FUSE TSC 125V 4.00A [C,A]
30	EI-346071	IC M5218L-21
31	EI-337228	IC M5218L0
32 N	EI-359221	IC M5226P
33 N	EI-358554	IC STK4152-2
34	EI-332259	IC TC4052BP
35	ER-200595	△ R FUSE ERD2FC S10 1/4W 5R6J
36	ES-349070	△ SW SELECTOR YKS11-0002 02-4 [U]
37 N	ES-359218	SW PUSH ESB-62951 2-02-02N
38 N	ES-359961	SW PUSH ESB621901 2 THROW
39	ES-337902	SW PUSH SDDL1P002 01-1
40	ET-349459	△ TR 2SD1406 O,Y,GR
41	ET-355216	TR 2SA1317 T,U
42	ET-353899	TR 2SA1317 S,T,U
43	ET-322598	TR 2SB632K E,F
44	ET-353898	TR 2SC3330
45	ET-360137	TR 2SC3330 U,V
46	ET-338565	TR 2SD1302 R,S
47 N	EV-359220	VR ROTARY 16P20x3Y B104
48 N	EV-359083	VR SLIDE 30PSVOH MN254
49 N	EV-359219	VR SLIDE 30P2SVOIW104

“NOTE” N: New Parts

SYMBOL FOR DESTINATION

- [A]: AAL (USA)
- [B]: UK (England)
- [C]: CSA (Canada)
- [E]: CEE (Europe)
- [S]: SAA (Australia)
- [U]: U/T (Universal Area)
- [V]: VDE (West Germany)

1. PC BOARD BLOCK

REF. NO.	PART NO.	DESCRIPTION
1-1A	BA-A2043A040A	PC PRE AMP BLK AM-A200 (U,C,A, E,B,S)
1-1B	BA-A0043A040B	PC PRE AMP BLK AM-A200(V)
1-2A	BA-A2043A020A	PC MAIN BLK AM-A200 (U)
1-2B	BA-A2043A020B	PC MAIN BLK AM-A200 (C,A)
1-2C	BA-A2043A020C	PC MAIN BLK AM-A200 (E,V,B,S)

NOTE:

PC PRE AMP BLK consists of following PC BOARDS.

- PRE AMP PC BOARD
- GRAPHIC EQ PC BOARD
- LED PD BOARD
- VOLUME PC BOARD

2. PRE AMP PC BOARD

REF. NO.	PART NO.	DESCRIPTION
2-IC1	EI-346071	IC M5218L-21
2-IC2	EI-332259	IC TC4052BP
2-IC3	EI-337228	IC M5218L0
2-TR1	ET-355216	TR 2SA1317 T,U
2-TR2	ET-353899	TR 2SA1317 S,T,U
2-TR3		
to TR7	ET-353898	TR 2SC3330
2-TR8	ET-338565	TR 2SD1302 R,S
2-D1	ED-357754	D SILICON DS135D 200/1.0A
2-D2	ED-301911	D SILICON H DS448
2-D3,D4	ED-346603	D ZENER H HZ6 A1
2-D9	ED-357754	D SILICON DS135D 200/1.0A
2-SW1	ES-359218	SW PUSH ESB-62951 2-02-02N
2-L1	EO-318635	COIL FIX 1 LAL04SK 2R2K [V]
2-J1	EJ-336905	PIN J AJC-035-ACB P 4P
2-J2	EJ-359067	SOCKET INLET HEC0470-01-640
2-P1	EJ-359178	PLUG CONNECTOR S7B-XH-A BLACK 7P

3. GRAPHIC EQ PC BOARD

REF. NO.	PART NO.	DESCRIPTION
3-IC4,		
IC5	EI-359221	IC M5226P
3-TR9		
to TR12	ET-353898	TR 2SC3330
3-VR1	EV-359083	VR SLIDE 30PSVOH MN254
3-VR2		
to VR10	EV-359219	VR SLIDE 30P2SVOI W104

4. MAIN PC BOARD

REF. NO.	PART NO.	DESCRIPTION
MAIN PC BOARD		
4-IC101	EI-358554	△ IC STK4152-2
4-TR102, TR103	ET-349459	△ TR 2SD1406 O,Y,GR
4-TR104	ET-322598	△ TR 2SB632K E,F
4-TR105	ET-353899	TR 2SA1317 S,T,U
4-TR106, TR107	ET-360137	TR 2SC3330 U,V
4-D101	ED-301911	D SILICON H DS448
4-D102	ED-329056	D ZENER H HZ22 2
4-D103	ED-337265	D ZENER H HZ6 C2
4-D104	ED-319176	D ZENER H HZ12 A3
4-D105	ED-346616	△ D ZENER H HZ12 B3
4-D106	ED-346617	△ D ZENER H HZ12 C2
4-D108, D109	ED-301911	D SILICON H DS448
4-D110	ED-322046	△ D ZENER H HZ18 1
4-D111	ED-302269	D ZENER H HZ5 A2
4-D112	ED-348200	△ D SILICON DBA20C-K15 200/2.0A
4-D113	ED-200213	△ D SILICON DBA40C-K15 200/2.6A
4-D114 to D116	ED-301911	D SILICON H DS448
4-L101	EO-337880	COIL FIX 2 202AK-018 2R2K
4-FR1,FR2	ER-200595	△ R FUSE ERD2FC S10 1/4W 5R6J
4-R107, R108	ER-324480	△ R CB H S10 FS RDS 1/4W 470J
4-R111, R112	ER-359351	△ R OMF H S12 FS 1W 4R7J
4-R116	ER-359269	△ R OMF H S12 FS 1W 221J
4-R121, R122	ER-322591	△ R CB H S10 FS RDS 1/4W 101J [C,A]
4-C114	EC-323846	C EC V CUT H 102M 35.0DC
4-C116, C117	EC-360113	C EC V S10 TS 472M 45.0DC
4-C118	EC-326583	C MMY V CUT CF921 473K 400DC
ASSEMBLY BLOCK		
4-TR101	ET-349459	△ TR 2SC1406 O,Y,GR
4-F3A	EF-306957	△ FUSE TSC 125V 4.00A [C,A]
4-F3B	EF-690996	△ FUSE SEMKO T 250V 4.00A [E,V,S]
4-F3C	EF-359086	△ FUSE BET T 4.00A 250V [B]
4-F4A	EF-306957	△ FUSE TSC 125V 4.00A [C,A]
4-F4B	EF-690996	△ FUSE SEMKO T 250V 4.00A [E,V,S]
4-F4C	EF-359086	△ FUSE BET T 4.00A 250V [B]
4-F5A	EF-308847	△ FUSE TSC 125V 1.60A [C,A]
4-F5B	EF-602550	△ FUSE SEMKO T 1.25A 250V [E,V,S]
4-F5C	EF-359007	△ FUSE BET T 1.25A 250V [B]
4-F6A	EF-306952	△ FUSE TSC A 250V 4.00A [U]
4-F6B	EF-306957	△ FUSE TSC 125V 4.00A [C,A]
4-F6C	EF-691007	△ FUSE SEMKO T 3.15A 250V [E,V,S]
4-F6D	EF-359225	△ FUSE BET T 3.15A 250V [B]
4-F7A	EF-306952	△ FUSE TSC A 250V 4.00A [U]
4-F7B	EF-306957	△ FUSE TSC 125V 4.00A [C,A]
4-F7C	EF-691007	△ FUSE SEMKO T 3.15A 250V [E,V,S]
4-F7D	EF-359225	△ FUSE BET T 3.15A 250V [B]

5. POWER SUPPLY PC BOARD

REF. NO.	PART NO.	DESCRIPTION
5-SW201	ES-337902	SW PUSH SDDL1P002 01-1
5-SW202	ES-359961	SW PUSH ESB621901 2 THROW
5-L201	EO-338409	COIL LF FKOB160MHO2 250UH [V]
5-L202, L203	EO-342936	COIL BALUN [V]
5-R201	ER-356573	△ R SD ANTI-STATIC 1/2W 225K [C,A]
5-R202	ER-359268	△ R OMF H S12 FS 1W 181J
5-C201A	EC-320548	C CE V F 103Z 250AC [U]
5-C201B	EC-314688	C CE V FZ 103P 125AC [C,A]
5-C201C	EC-338496	C CE V FZ472P 400AC [E,B,S]
5-TM201	EJ-349061	TERMINAL PUSH YKD21-0025 P 8P
5-J201	EJ-359222	PHONE J 3P HLJ4318-3020 6.3 20
5-F1A	EF-311839	△ FUSE TSC A 250V 1.60A [U]
5-F1B	EF-323080	△ FUSE TSC 125V 3.15A [C,A]
5-F1C	EF-602550	△ FUSE SEMKO T 1.25A 250V [E,V,S]
5-F1D	EF-359007	△ FUSE BET T 1.25A 250V [B]
5-F2	EF-311839	△ FUSE TSC A 250V 1.60A [U]

6. LED PC BOARD

REF. NO.	PART NO.	DESCRIPTION
6-D5 to D8	ED-337391	D LED GL5NG6 GREEN

7. VOLUME PC BOARD

REF. NO.	PART NO.	DESCRIPTION
7-VR11	EV-359220	VR ROTARY 16P20×3Y B104

8. CONNECTOR (A) PC BOARD

REF. NO.	PART NO.	DESCRIPTION
8-J901	EJ-356521	SOCKET CONNECTOR-B M1701-A 12P

9. CONNECTOR (B) PC BOARD

REF. NO.	PART NO.	DESCRIPTION
9-P901	EJ-356522	PLUG CONNECTOR-B M1690-A 12P

ASSEMBLY BLOCK

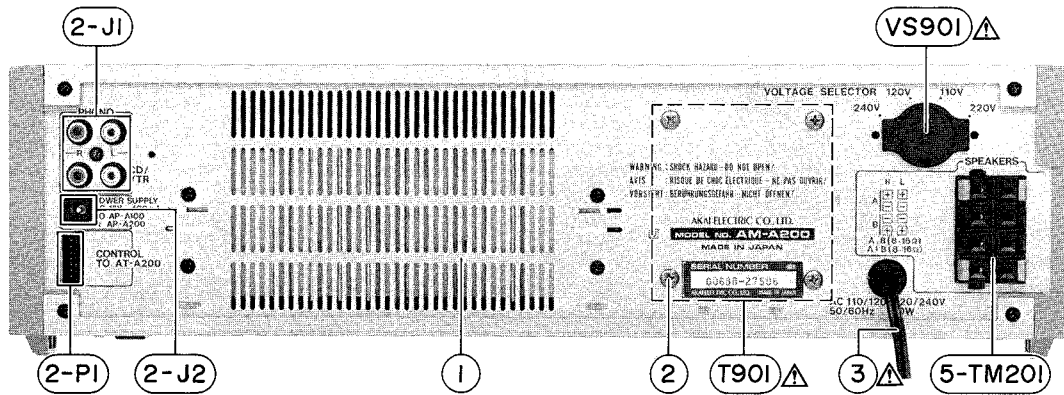

10. ASSEMBLY BLOCK

REF. NO.	PART NO.	DESCRIPTION
ASSEMBLY BLOCK		
10-1A	SP-358990E	PANEL REAR AM-A200(U)
10-1B	SP-358990C	PANEL REAR AM-A200(A,C)
10-1C	SP-358990A	PANEL REAR AM-A200(E,V)
10-1D	SP-358990B	PANEL REAR AM-A200(B,S)
10-2	ZS-322580	ST BID40X08STL BNI [POWER TRANS FIX]
10-3A	EW-359076	△ AC CORD C1005 U [U]
10-3B	EW-359077	△ AC CORD CD1005 C [C]
10-3C	EW-359078	△ AC CORD 2 CORES VM02380 SPT-1-CB UC [A]
10-3D	EW-359079	△ AC CORD 2 CORES VM0364 LC2×0.75CBEV [E,V]
10-3E	EW-359204	△ AC CORD 2 CORES LC2×0.75-CB B [B]
10-3F	EW-359081	AC CORD 2 CORES VM0436 LC2×0.75CB S [S]
10-T901A	BT-359193	△ TRANS POWER A2043T-70 (U)
10-T901B	BT-359194	△ TRANS POWER A2043T-30 (C)
10-T901C	BT-359195	△ TRANS POWER A2043T-20 (A)
10-T901D	BT-359196	△ TRANS POWER JA2043T-40 (E,V)
10-T901E	BT-359197	△ TRANS POWER A2043T-50 (B,S)
10-VS901	ES-349070	△ SW SELECTOR YKS11-0002 02-4 [U]
PRE AMP PC BOARD		
2-J1	EJ-336905	PIN J AJC-035-ACB P 4P
2-J2	EJ-359067	SOCKET INLET HEC0470-01-640
2-P1	EJ-359178	PLUG CONNECTOR S7B-XH-A BLACK 7P
POWER SUPPLY PC BOARD		
5-TM201	EJ-349061	TERMINAL PUSH YKD21-0025 P8P

FINAL ASSEMBLY BLOCK

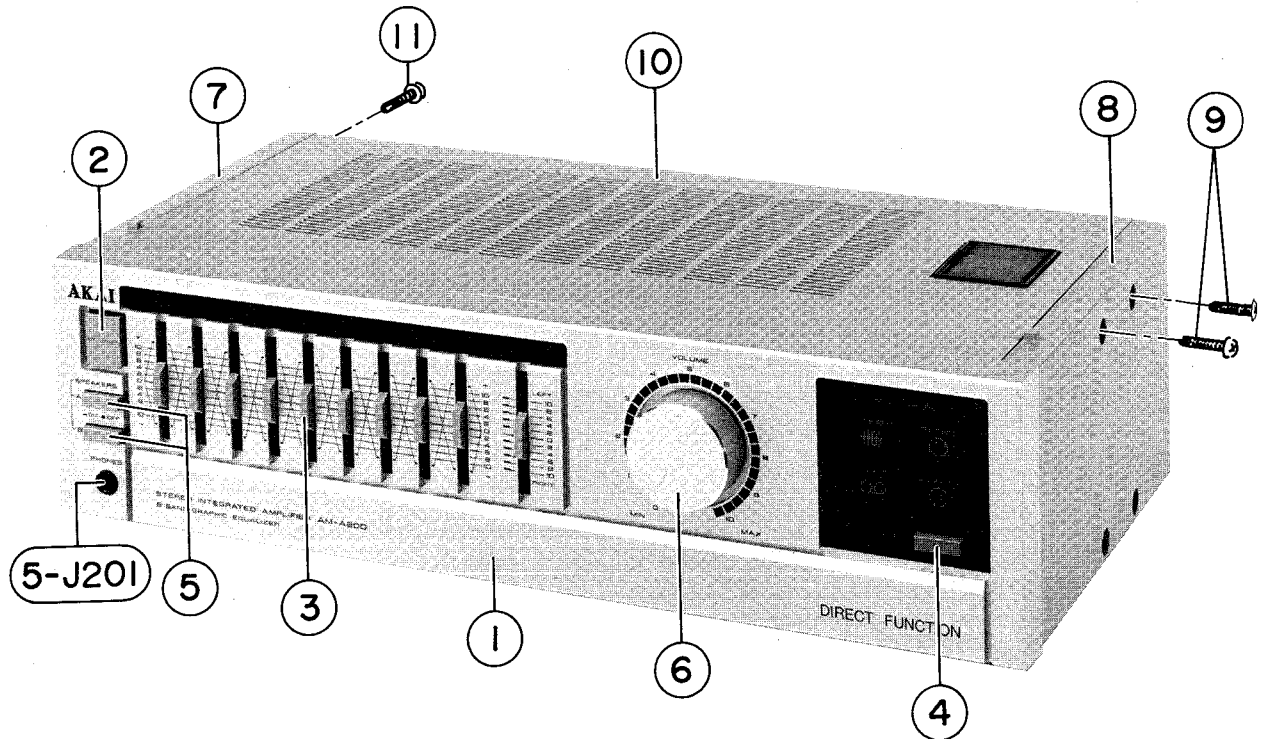

11. FINAL ASSEMBLY BLOCK

REF. NO.	PART NO.	DESCRIPTION
PANEL FRONT BLOCK		
11-1	BD-A2043A050A	PANEL FRONT BLK AM-A200
11-1B	BD-A2043A050B	PANEL FRONT BLK AM-A200-B
11-2	SK-343017C	KNOB POWER (2)
11-2B	SK-343017F	KNOB POWER-B
11-3	SK-358879	KNOB SLIDE
FINAL ASSEMBLY BLOCK		
11-4	SB-358882	BUTTON PUSH
11-5	SB-358882B	BUTTON PUSH(2)
11-6	SK-B358605X2	KNOB VR (Y) PART
11-6B	SK-B358605X4	KNOB VR (Y)-B PART
11-7	BD-358994A	PANEL SLIDE (L)
11-7B	BD-358994B	PANEL SIDE(L)-B
11-8	BD-358995A	PANEL SIDE (R)
11-8B	BD-358995B	PANEL SIDE(R)-B
11-9	ZS-359179	PT BR 30x12STL BNI C [J901 FIX]
11-10	BC-358993C	COVER A-1
11-10B	BC-358993H	COVER A-1B
11-11	ZS-359226	T2BR30X10STL BZN [COVER A-1 FIX]
POWER SUPPLY PC BOARD		
5-J201	EJ-359222	PHONE J 3P HLJ4318-3020 6.3 20

NOTE:
PANEL FRONT BLK consists of 11-2 and 11-3.

V. MODEL HX-A200

RECOMMENDED SPARE PARTS

Because, if the parts listed below are on hand, almost any repair can be accomplished, we suggest that you stock these Recommended Spare Parts Items.

REF. NO.	PART NO.	DESCRIPTION
1	BF-712807	FLYWHEEL ASSY
2	BL-712799	PINCH ROLLER ARM ASSY
3	BM-712825	△ MOTOR (W/PULLEY) ASSY D0.
4	BR-715919	SUPPLY REEL ASSY
5	BR-715918	TAKE-UP REEL ASSY
6	ED-330996	D LED GL5HY5 YELLOW
7	ED-337391	D LED GL5NG6 GREEN
8	ED-321269	D LED GL5PR6 RED
9	ED-344280	D SILICON H GMA-01-FY2 F05
10	ED-324014	D ZENER H HZ11 B1
11	ED-331617	D ZENER H HZ6 A3
12	EH-351182	FILTER DB 201AK-005 100KHZ
13	EI-349591	IC LA2730
14	EI-345551	IC LB1403
15	EO-349589	COIL OSC 1 32-5016-12
16 N	ES-716377	SW LEAF LSA-1120YN
17	ES-713179	SW LSA-1123-37
18 N	ES-362802	SW PUSH ESB-621574 4 THROW
19 N	ES-359071	SW PUSH ESB-62771 2-02-02N
20 N	ES-359192	SW PUSH SPUL12 2-02-02N
21 N	ES-359189	SW SLIDE SSC17 1-07-02S
22	ET-308977	TR 2SC2274K F
23	ET-344275	TR 2SC2320L F,G
24	ET-360137	TR 2SC3330 U,V
25	ET-349081	TR 2SC3383 S,T
26	ET-350795	TR 2SC3399
27	ET-349366	TR 2SC3402
28	ET-310148	TR 2SD612K E,F
29 N	EV-356582	R S-FIX M H0615C 3P 473
30	HE-337047	HEAD E HAJAB3040A C
31	HP-712824	HEAD R/P HY424528 SVK
32	MB-712818	BELT AUTO
33	MB-712820	BELT DRIVE
34	MB-712819	BELT FR
35	MB-351605	BELT 0.8xD593 CRHS65
36	MC-353312	COUNTER MK395-043 (BLACK)
37	MI-715935	CLUTCH ARM ASSY
38	MI-712813	GEAR ATUO
39	MI-711710	GEAR C
40	MI-712814	GEAR CAM AUTO
41	MI-712804	GEAR FF
42	MI-712817	IDLER PLAY
43	MI-712812	PULLEY AUTO

“NOTE” N: New Parts
SYMBOL FOR DESTINATION
[A]: AAL (USA)
[B]: UK (England)
[C]: CSA (Canada)
[E]: CEE (Europe)
[S]: SAA (Australia)
[U]: U/T (Universal Area)
[V]: VDE (West Germany)

MECHA BLOCK

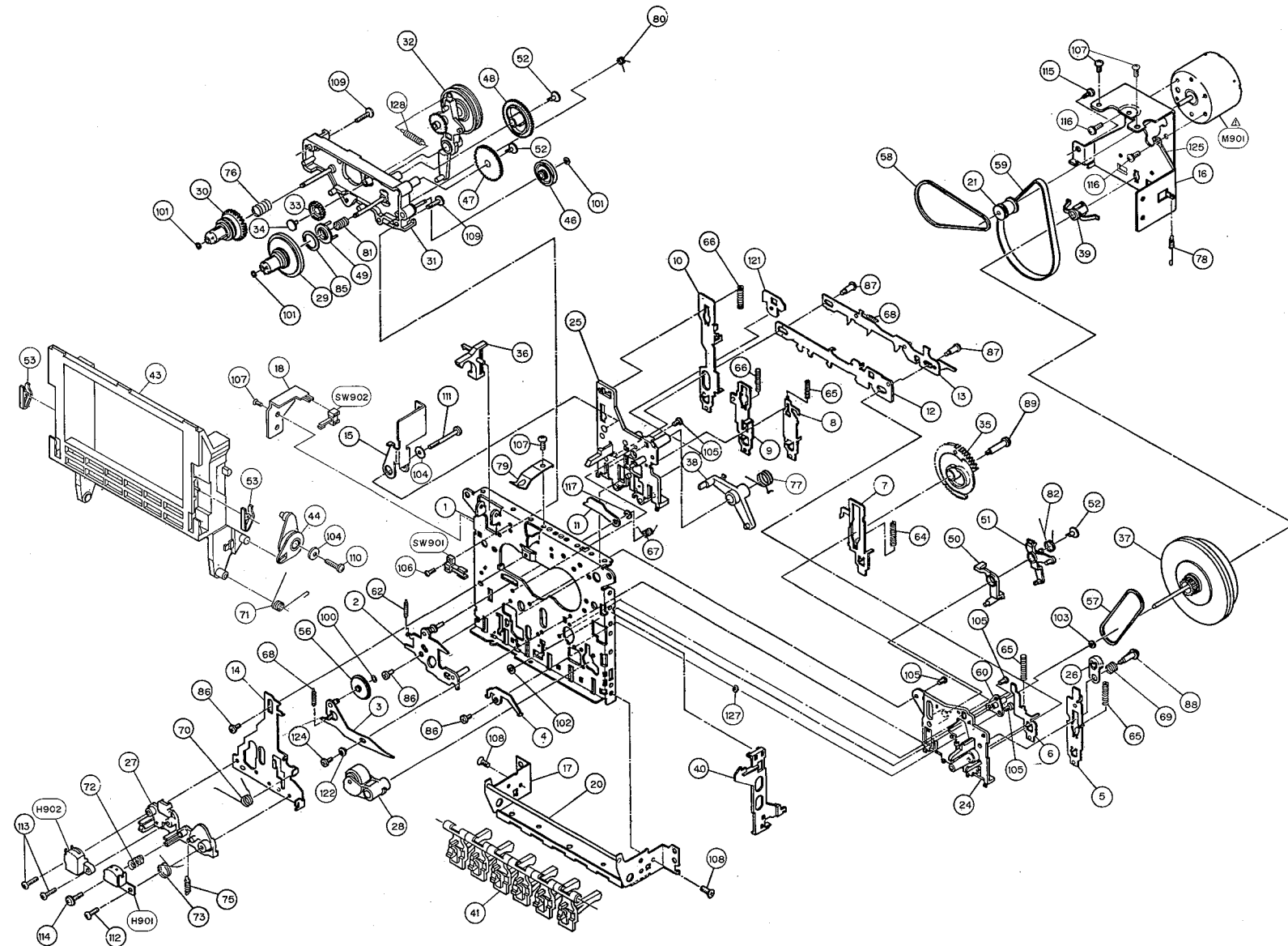

1. MECHA BLOCK

REF. NO.	PART NO.	DESCRIPTION	REF. NO.	PART NO.	DESCRIPTION	REF. NO.	PART NO.	DESCRIPTION
1-1	BB-359082	MECHA AKI-95 FMF C1005 BLK	1-47	MI-712813	GEAR AUTO	1-80	ZG-716194	SP AUTO SENSER
1-24	ML-716375	LEVER HOLDER (A)	1-48	MI-712814	GEAR CAM AUTO	1-81	ZS-716355	SP AUTO CLUTCH
1-26	MZ-716171	CAM PAUSE	1-49	MI-715920	CLUTCH AUTO	1-82	ZG-716197	SP UATO LOCK ARM
1-27	HZ-716172	HEAD BASE	1-50	ML-716179	ARM AUTO(B)	1-85	TC-712823	FELT AUTO CLUTCH
1-28	BL-712799	PINCH ROLLER ARM ASSY	1-51	ML-716180	ARM ATUO LOCK	1-112	ZS-536488	BID20x08STL CMT
1-29	BR-715918	TAKE-UP REEL ASSY	1-52	ZW-716181	BUSH	1-113	ZS-749292	BID20x8.5STL CMT
1-30	BR-715919	SUPPLY REEL ASSY	1-53	ZG-712816	CLMAP CASSETTE	1-114	ZS-749293	BID20x09STL CMT TW
1-32	MI-715935	CLUTCH ARM ASSY	1-56	MI-712817	IDLER PLAY	1-128	ZG-715922	SP CLUTCH ARM
1-33	MI-712804	GEAR FF	1-57	MB-712818	BELT AUTO	1-H901	HP-712824	HEAD R/P HY424528 SVK
1-34	MZ-749256	BUSH	1-58	MB-712819	BELT FR	1-H902	HE-337047	HEAD E HAJAB3040A C
1-35	MI-711710	GEAR C	1-59	MB-712820	BELT DRIVE	1-M901	BM-712825	△ MOTOR (W/PULLEY) ASSY
1-36	ML-712806	REC SENSOR	1-60	MV-716186	MAIN CASE	1-SW901	ES-716377	SW LEAF LSA-1120YN
1-37	BF-712807	FLYWHEEL L ASSY	1-67	ZG-716187	SP REC LEVER	1-SW902	ES-713179	SW LSA-1123-37
1-38	ML-716175	ARM LOCK (H)	1-68	ZG-716188	SP CAM			
1-39	MZ-712808	HOLDER CAPSTAN	1-69	ZG-716189	SP PAUSE CAM			
1-40	ML-712809	LEVER EJECT	1-70	ZG-716190	SP HEAD CHASSIS			
1-41	SB-716178	BUTTON LEVER	1-72	ZG-749268	SP HEAD			
1-43	TC-712810	LID FRAME	1-73	ZG-715921	SP PINCH ROLLER			
1-44	TC-712811	DAMPER ASSY	1-75	ZG-715940	SP HEAD RETURN			
1-46	MI-712812	PULLEY AUTO	1-78	ZG-716193	SP EJECT LEVER			
			1-79	ZG-712822	SP PACK			

Note:
Parts will not be supplied if they are not listed in the parts list, even if they appear on the assembling illustrations with reference No.

2. PC BOARD BLOCK

REF. NO.	PART NO.	DESCRIPTION
2-1	BA-T2085A020A	PC PRE AMP BLK HX-A200

6. LED PC BOARD

REF. NO.	PART NO.	DESCRIPTION
6-D207	ED-321269	D LED GL5PR6 RED
6-D208	ED-337391	D LED GL5NG6 GREEN

NOTE:

PC PRE AMP LBK consists of following PC BOARDS.

- PRE AMP PC BOARD
- STAND BY SW PC BOARD
- LED PC BOARD

3. PRE AMP PC BOARD

REF. NO.	PART NO.	DESCRIPTION
3-IC201	EI-349591	IC LA2730
3-TR201	ET-344275	TR 2SC2320L F,G
3-TR202	ET-350795	TR 2SC3399
3-TR203 to TR207	ET-349081	TR 2SC3383 S,T
3-TR208, TR209	ET-308977	TR 2SC2274K F
3-TR210	ET-360137	TR 2SC3330 U,V
3-TR211	ET-310148	TR 2SD612K E,F
3-TR212	ET-360137	TR 2SC3330 U,V
3-TR213	ET-349366	TR 2SC3402
3-TR214, TR215	ET-349081	TR 2SC3383 S,T
3-TR216, TR217	ET-349366	TR 2SC3402
3-D201 to D203	ED-344280	D SILICON H GMA-01-FY2 F05
3-D204	ED-331617	D ZENER H HZ6 A3
3-D205	ED-324014	D ZENER H HZ11 B1
3-SW201	ES-359189	SW SLIDE SSK17 1-07-02S
3-SW202	ES-362082	SW PUSH ESB-621574 4 THROW [INCLUDING SW203]
3-SW203	ES-359071	SW PUSH ESB-62771 2-02-02N
3-VR201 to VR203	EV-356582	R S-FIX H H0615C 3P 473
3-FL201	EH-351182	FILTER DB 201AK-005 100KHZ
3-FL202	EO-356809	COIL FIX 1 100Z-121 100.00KC
3-L201	EO-357050	COIL FIX 1 RC875 822J
3-T201	EO-349589	COIL OSC 1 32-5016-12
3-C232	EC-347263	C MC V F05 FM 221J 500DC
3-C237	EC-326138	C PP V F10 APH 182J 630DC

4. LEVEL METER PC BOARD

REF. NO.	PART NO.	DESCRIPTION
4-IC101	EI-345551	IC LB1403
4-D1,D2	ED-337391	D LED GL5NG6 GREEN
4-D3,D4	ED-330996	D LED GL5HY5 YELLOW
4-D5	ED-321269	D LED GL5PR6 RED

5. STAND BY SW PC BOARD

REF. NO.	PART NO.	DESCRIPTION
5-SW204	ES-359192	SW PUSH SPUL12 2-02-02N

ASSEMBLY BLOCK

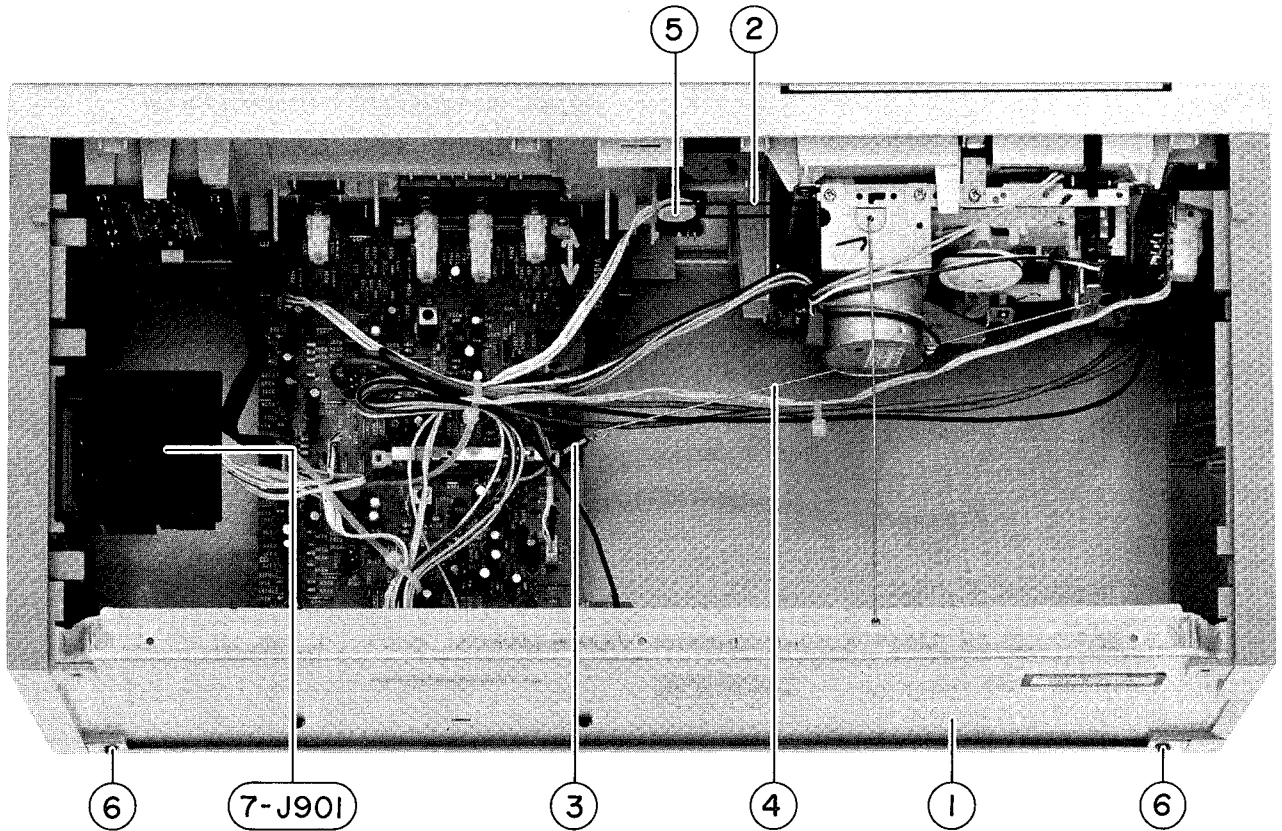

7. ASSEMBLY BLOCK

REF. NO.	PART NO.	DESCRIPTION
7-1	SP-359004	PANEL REAR HX-A200
7-2	MB-351605	BELT 0.8xD593 CRHS65
7-3	ZG-359249	SP REC
7-4	MZ-359250	JOINT REC
7-5	MC-353312	COUNTER MK395-043 (BLACK)
7-6	ZS-309315	T 2BR30x10STL BNI
7-J901	EJ-356521	SOCKET CONNECTOR-B M1701-A 12P

FINAL ASSEMBLY BLOCK

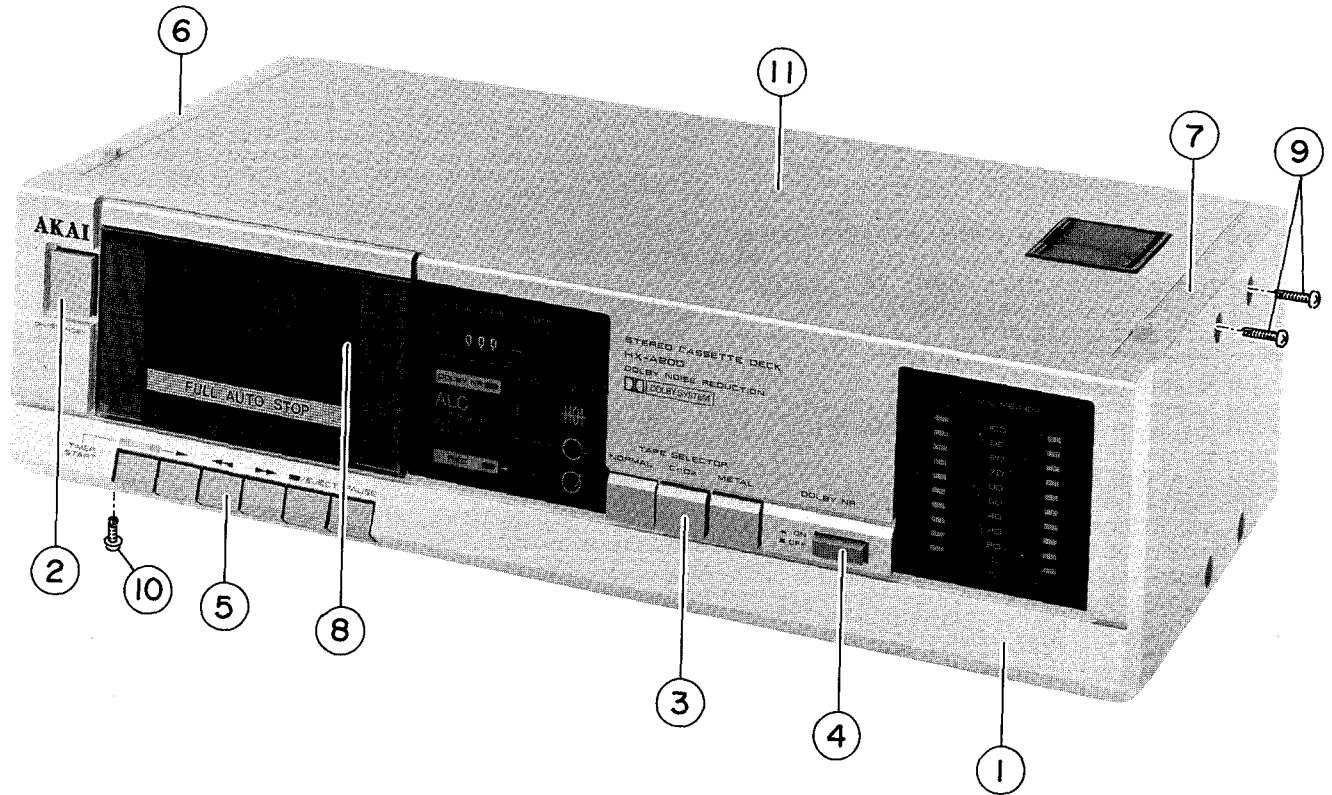

8. FINAL ASSEMBLY BLOCK

REF. NO.	PART NO.	DESCRIPTION
8-1	BD-358999A	PANEL FRONT
8-1B	BD-358999B	PANEL FRONT-B
8-2	SK-343017C	KNOB POWER (2)
8-2B	SK-343017F	KNOB POWER-B
8-3	SK-359001A	KNOB TAPE SELECT
8-3B	SK-359001B	KNOB TAPE SELECT-B
8-4	SB-358882	BUTTON PUSH
8-5	SB-358886A	BUTTON OPERATION
8-6	BD-358994A	PANEL SIDE (L)
8-6B	BD-358994B	PANEL SIDE(L)-B
8-7	BD-358995A	PANEL SIDE (R)
8-7B	BD-358995B	PANEL SIDE(R)-B
8-8	BD-359000A	PANEL LID
8-8B	BD-359000B	PANEL LID-B
8-9	ZS-359179	PT BR30×12STL BNI C [J901 FIX]
8-10	ZS-359702	S T BR26×06STL BNI [MECHA, BOTTOM COVER SIX]
8-11	BC-358993E	COVER D-1
8-11B	BC-358993J	COVER D-1B

NOTE: SYMBOL FOR COLOR VARIATION
 NON : STANDARD COLOR
 B or BL : BLACK

VI. MODEL HX-A300W

RECOMMENDED SPARE PARTS

Because, if the parts listed below are on hand, almost any repair can be accomplished, we suggest that you stock these Recommended Spare Parts Items.

REF. NO.	PART NO.	DESCRIPTION
1	BM-712825	△ MOTOR (W/PULLEY) ASSY EG-500 AD-2
2	BR-715919	SUPPLY REEL ASSY
3	BR-715918	TAKE-UP REEL ASSY
4	ED-357691	D LED GL-9HY23 YELLOW
5 N	ED-358085	D LED GL-9NG23 GRN
6	ED-351881	D LED GL-9PR23 RED
7	ED-349662	D SILICON DS135E-FA6 100/1.0A
8	ED-344280	D SILICON H GMA-01-FY2 F05
9	ED-324014	D-ZENER H HZ11 B1
10	ED-348014	D ZENER V HZ4A-1S7
11	EH-336776	FILTER DB D07003K 100KHZ
12	EI-349590	IC BA328OEC
13	EI-347634	IC HA12045
14 N	EI-355388	IC IR2E27
15	EI-337228	IC M5218L0
16	EO-353311	COIL OSC 32-5021-12 100KHZ
17	ER-318647	△ R FUSE ERD2FC S10 1/4W 4R7J
18	ES-715945	SW LEAF LSA-1119C
19	ES-715944	SW LEAF LSA-1132EAU
20	ES-713179	SW LSA-1123-37
21	ES-347966	SW PUSH ESB-649 01-2-2 N
22 N	ES-358646	SW PUSH SUL121S 1-012-02N
23 N	ES-359242	SW PUSH SUY12A 2-02-02S
24 N	ES-358580	SW SLIDE CL108K
25	ET-308472	TR 2SA1115 E,F,G
26	ET-348931	TR 2SB774 R,S,T
27	ET-308977	TR 2SC2274K F
28	ET-349705	TR 2SC2320 E,F,G
29	ET-349272	TR 2SC3242A E,F
30	ET-349366	TR 2SC3402
31	EV-357619	R S-FIX H H0615C 3P 104
32 N	EV-358829	R S-FIX H H0615C 3P 223
33 N	EV-356581	R S-FIX H0615C 3P 331
34	EV-357689	VR SLIDE 60P2SVOL A503
35	HE-337047	HEAD E HAJAB3040A C
36	HP-712824	HEAD R/P HY424528 SVK
37	MB-712818	BELT AUTO
38 N	MB-355124	BELT COUNTER
39	MB-712820	BELT DRIVE
40	MB-712819	BELT FR
41 N	MC-358569	COUNTER MMP 382-016
42	MI-715935	CLUTCH ARM ASSY
43	MI-712813	GEAR AUTO
44	MI-711710	GEAR C
45	MI-712814	GEAR CAM AUTO
46	MI-712804	GEAR FF
47	MI-712817	IDLER PLAY
48	MI-712812	PULLEY AUTO
49 N	MZ-716577	MAIN CASE ASSY

“NOTE” N: New Parts

SYMBOL FOR DESTINATION

- [A]: AAL (USA)
- [B]: UK (England)
- [C]: CSA (Canada)
- [E]: CEE (Europe)
- [S]: SAA (Australia)
- [U]: U/T (Universal Area)
- [V]: VDE (West Germany)

MECHA (REC/PB) BLOCK

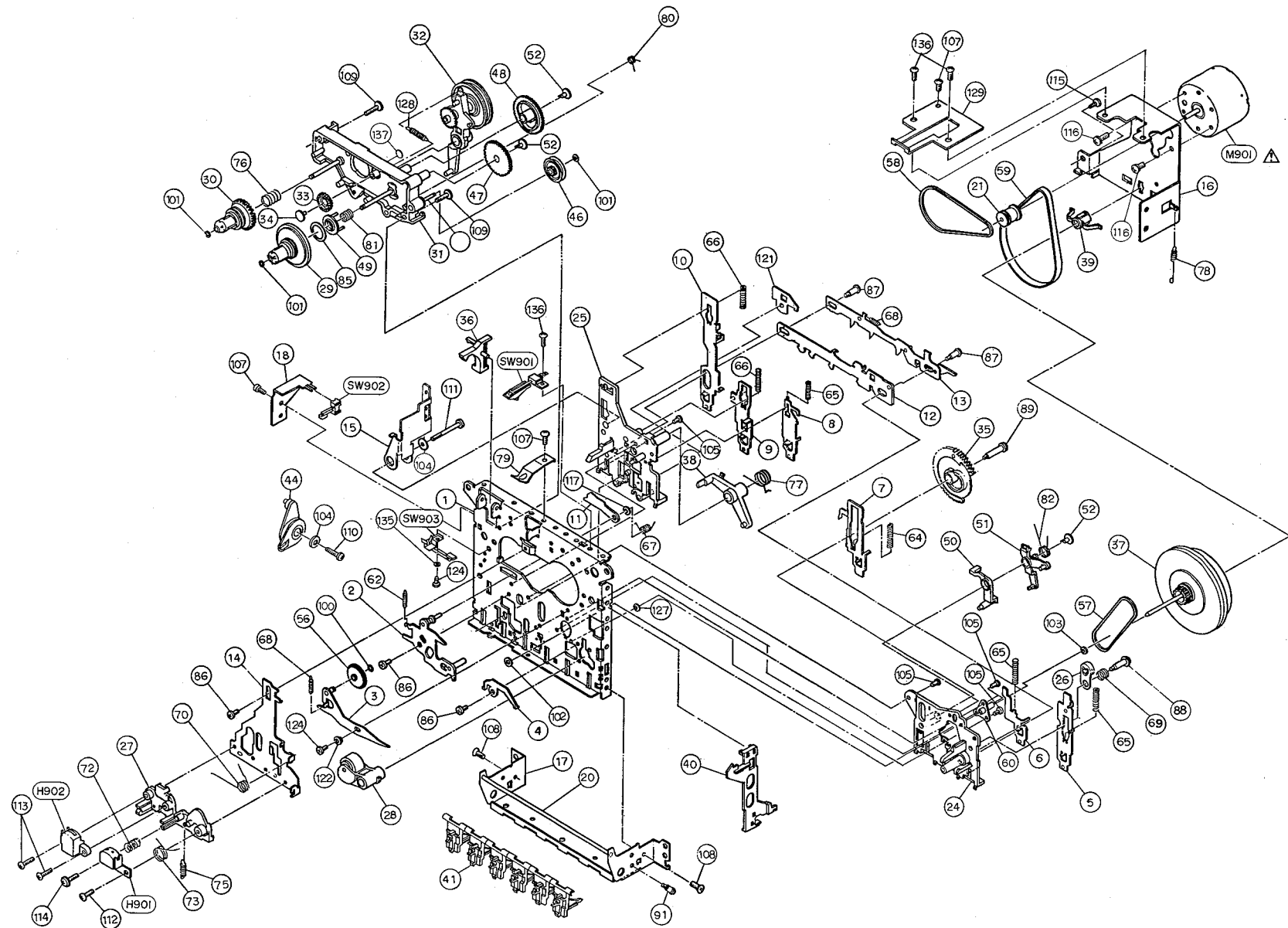

1. MECHA (REC/PB) BLOCK

REF. NO.	PART NO.	DESCRIPTION	REF. NO.	PART NO.	DESCRIPTION	REF. NO.	PART NO.	DESCRIPTION
1-1	BB-355186	MECHA AKI-96FMF	1-49	MI-715920	CLUTCH AUTO	1-82	ZG-716197	SP AUTO LOCK ARM
1-24	ML-716375	LEVER HOLDER (A)	1-50	ML-716179	ARM AUTO(B)	1-85	TC-712823	FELT AUTO CLUTCH
1-26	MZ-716171	CAM PAUSE	1-51	ML-716180	ARM AUTO LOCK	1-87	ZS-715982	SCREW(B)
1-27	HZ-716172	HEAD BASE	1-52	ZW-716181	BUSH	1-88	ZS-716203	SCREW SPECIAL (C)
1-28	BL-712799	PINCH ROLLER ARM ASSY	1-56	MI-712817	IDLER PLAY	1-89	ZS-716204	SCREW SPECIAL (D)
1-29	BR-715918	TAKE-UP REEL ASSY	1-57	MB-712818	BELT AUTO	1-91	ZS-716580	SCREW SPECIAL
1-30	BR-715919	SUPPLY REEL ASSY	1-58	MB-712819	BELT FR	1-112	ZS-536488	BID20X08STL CMT
1-32	MI-715935	C LUTCH ARM ASSY	1-59	MB-712820	BELT DRIVE	1-113	ZS-749292	BID20X8.5STL CMT
1-33	MI-712804	GEAR FF	1-60	MZ-716577	MAIN CASE ASSY	1-114	ZS-749293	BID20X09STL CMT TW
1-34	MZ-749256	BUSH	1-67	ZG-716187	SP REC LEVER	1-128	ZG-715922	SP CLUTCH ARM
1-35	MI-711710	GEAR C	1-68	ZG-716188	SP CAM	1-M901	BM-712825	△ MOTOR (W/PULLEY) ASSY
1-36	ML-712806	REC SENSOR	1-69	ZG-716189	SP PAUSE CAM			EG-500AD-2B
1-37	BF-712807	FLYWHEEL ASSY	1-70	ZG-716190	SP HEAD CHASSIS	1-SW901	ES-715944	SW LEAF LSA-1132EAU
1-38	ML-716175	ARM LOCK (H)	1-72	ZG-749268	SP HEAD	1-SW902	ES-713179	SW LSA-1123-37
1-39	MZ-712808	HOLDER CAPSTAN	1-73	ZG-715921	SP PINCH ROLLER	1-SW903	ES-715945	SW LEAF LSA-1119C
1-40	ML-712809	LEVER EJECT	1-75	ZG-715940	SP HEAD RETURN	1-H901	HP-712824	HEAD R/P HY424528 SVK
1-41	SB-716178	BUTTON LEVER	1-76	ZG-716578	SP BACK RENSIION	1-H902	HE-337047	HEAD E HAJAB3040A C
1-44	TC-712811	DAMPER ASSY	1-77	ZG-716579	SP LOCK ARM			Note:
1-46	MI-712812	PULLEY AUTO	1-78	ZG-716193	SP EJECT LEVER			Parts will not be supplied if they are not listed in the
1-47	MI-712813	GEAR AUTO	1-79	ZG-712822	SP PACK			parts list, even if they appear on the assembling illustrations
1-48	MI-712814	GEAR CAM AUTO	1-80	ZG-716194	SP AUTO SENSER			with reference No.
			1-81	ZS-716355	SP AUTO CLUTCH			

PARTS LIST

MECHA (PB) BLOCK

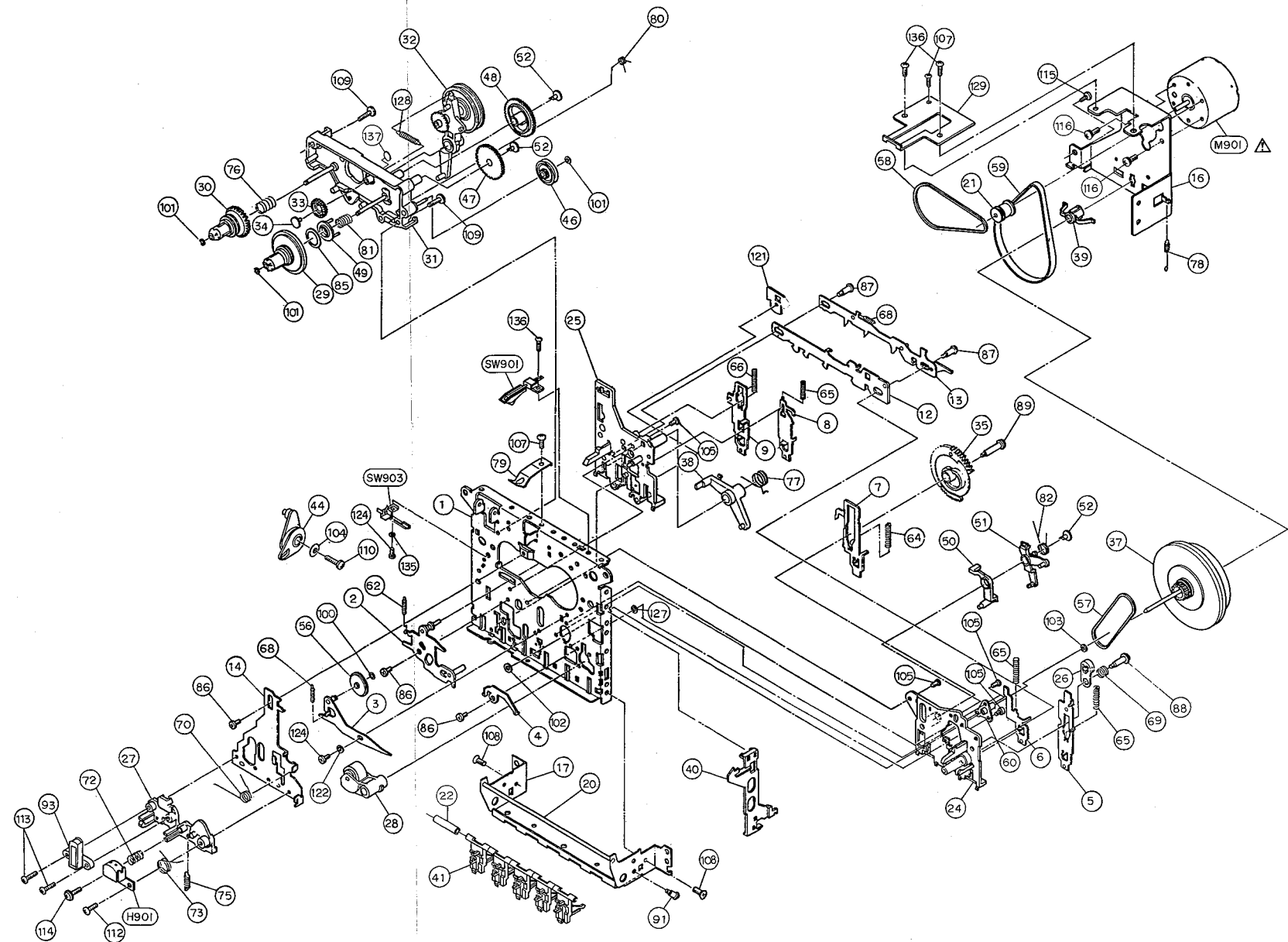

2. MECHA (PB) BLOCK

REF. NO.	PART NO.	DESCRIPTION
2-1	BB-355187	MECHA AKI-97FMF
2-22	MZ-716582	COLLAR BUTTON
2-24	ML-716375	LEVER HOLDER (A)
2-26	MZ-716171	CAM PAUSE
2-27	MZ-716172	HWAD BASE
2-28	BL-712799	PINCH ROLLER AM ASSY
2-29	BR-715918	TAKE-UP REEL ASSY
2-30	BR-715919	SUPPLY REEL ASSY
2-32	MI-715935	CLUTCH ARM ASSY
2-33	MI-712804	GEAR FF
2-34	MZ-749256	BUSH
2-35	MI-711710	GEAR C
2-37	BF-712807	FLYWEHEEL ASSY
2-39	MZ-712808	HOLDER CAPTSTAN
2-40	ML-712809	LEVER EJECT
2-41	SB-716178	BUTTON LEVER
2-44	TC-712811	DAMPER ASSY
2-46	MI-712812	PULLEY AUTO
2-47	MI-712813	GEAR AUTO
2-48	MI-712814	GEAR CAM AUTO
2-49	MI-715920	CLUTCH ATUO

REF. NO.	PART NO.	DESCRIPTION
2-50	ML-716179	ARM AUTO (B)
2-51	ML-716180	ARM AUTO LOCK
2-52	ZW-716181	BUSH
2-56	MI-712817	IDLER PLAY
2-57	MB-712818	BELT AUTO
2-58	MB-712819	BELT FR
2-59	MB-712820	BELT DRIVE
2-60	MZ-716577	MAIN CASE ASSY
2-68	ZG-716188	SP CAM
2-69	ZG-716189	SP PAUSE CAM
2-70	ZG-716190	SP HEAD CHASSIS
2-72	ZG-749268	SP HEAD
2-73	ZG-715921	SP PINCH ROLLER
2-75	ZG-715940	SP HEAD RETURN
2-76	ZG-716578	SP BACK TENSION
2-77	ZG-716579	SP LOCK ARM
2-78	ZG-716193	SP EJECT LEVER
2-79	ZG-712822	SP PACK
2-80	ZG-716194	SP AUTO SENSER
2-81	ZS-716355	SP AUTO CLUTCH
2-82	ZG-716197	SP AUTO LOCK ARM

REF. NO.	PART NO.	DESCRIPTION
2-85	TC-712823	FELT AUTO CLUTCH
2-87	ZS-715982	S SCREW (B)
2-88	ZS-716203	SCREW SPECIAL (C)
2-89	ZS-716204	SCREW SPECIAL (D)
2-91	ZS-716580	SCREW SPECIAL
2-93	MS-715941	TAPE GUIDE
2-112	ZS-536488	BID20x08STL CMT
2-113	ZS-749292	BID20x8.5STL CMT
2-114	ZS-749293	BID20x09STL CMT TW
2-118	ZS-716576	SCREW SPECIAL MOTOR
2-128	ZG-715922	SP CLUTCH ARM
2-M901	BM-712825	△ MOTOR (W/PULLEY) ASSY EG-500AD-2B
2-SW901	ES-715944	SW LEAF LSA-1132EAU
2-SW903	ES-715945	SW LEAF LSA-1119C
2-H901	HP-712824	HEAD R/P HY424528 SVK

Note:

Parts will not be supplied if they are not listed in the parts list, even if they appear on the assembling illustrations with reference No.

3. PC BOARD BLOCK

REF. NO.	PART NO.	DESCRIPTION
3-1	BA-T2086A020A	PC PRE AMP BLK HX-A300W

4. PRE AMP PC BOARD

REF. NO.	PART NO.	DESCRIPTION
4-IC3C1, IC302	EI-349590	IC BA3280EC
4-IC303	EI-337228	IC M5218L0
4-IC304	EI-347634	IC HA12045
4-TR103	EI-349705	TR 2SC2320 E,F,G
4-TR105 to TR107	ET-349705	TR 2SC2320 E,F,G
4-TR111 to TR114	ET-349705	TR 2SC2320 E,F,G
4-TR117	ET-349705	TR 2SC2320 E,F,G
4-TR203	ET-349705	TR 2SC2320 E,F,G
4-TR205 to TR207	ET-349705	TR 2SC2320 E,F,G
4-TR211 to TR214	ET-349705	TR 2SC2320 E,F,G
4-TR217	ET-349705	TR 2SC2320 E,F,G
4-TR301, TR302	ET-308977	TR 2SC2274K F
4-TR303	ET-349705	TR 2SC2320 E,F,G
4-TR304	ET-349272	TR 2SC3242A E,F
4-TR305	ET-349366	TR 2SC3402
4-TR306	ET-349705	TR 2SC2320 E,F,G
4-TR308	ET-349705	TR 2SC2320 E,F,G
4-TR309	ET-348931	TR 2SB774 R,S,T
4-TR310	ET-349705	TR 2SC2320 E,F,G
4-TR311	ET-308472	TR 2SA1115 E,F,G
4-TR314	ET-349705	TR 2SC2320 E,F,G
4-TR318 to TR320	ET-349366	TR 2SC3402
4-D303	ED-324014	D ZENER H HZ11 B1
4-D304	ED-349662	D SILICON DS135E-FA6 100/1.0A
4-D305 to D308	ED-344280	D SILICON H GMA-01-FY2 F05
4-D310,D311	ED-344280	D SILICON H GMA-01-FY2 F05
4-D316	ED-349662	D SILICON DS135E-FA6 100/1.0A
4-D317 to D319	ED-344280	D SILICON H GMA-01-FY2 F05
4-D320	ED-348014	D ZENER V HZ4A-1S7
4-D321, D322	ED-344280	D SILICON H GMA-01-FY2 F05
4-SW301	ES-358580	SW SLIDE CL108K
4-VR101, VR102	EV-356581	R S-FIX H0615C 3P 331
4-VR103	EV-358829	R S-FIX H H06155C 3P 223
4-VR104	EV-357619	R S-FIX H H0615C 3P 104
4-VR201, VR202	EV-356581	R S-FIX H0615C 3P 331
4-VR203	EV-358829	R S-FIX H H0615C 3P 223
4-VR204	EV-357619	R S-FIX H H0615C 3P 104
4-FL101	EH-336776	FILTER DB D07003K 100KHZ
4-FL102	EO-356809	COIL FIX 1 100Z-121 100.00KC
4-FL201	EH-336776	FILTER DB D07003K 100KHZ
4-FL202	EO-356809	COIL FIX 1 100Z-121 100.00KC
4-L101, L201	EO-348235	COIL FIX1 L-8 682J
4-T301	EO-353311	COIL OSC 32-5021-12 100KHZ
4-FR301	ER-318647	△ R FUSE ERD2FC S10 1/4W 4R7J
4-C102	EC-334068	C STY V F05 CQ09S 271J 50DC
4-C110	EC-334068	C STY V F05 CQ09S 271J 50DC
4-C146	EC-347228	C MC V F05 FM 470J 500DC
4-C202	EC-334068	C STY V F05 CQ09S 271J 50DC
4-C210	EC-334068	C STY V F05 CQ09S 271J 50DC
4-C246	EC-347228	C MC V F05 FM 470J 500DC
4-C309	EC-345817	C PP V F10 APH 272J 630DC

5. METER PC BOARD

REF. NO.	PART NO.	DESCRIPTION
METER PC BOARD		
5-IC501	EI-355388	IC IR2E27
5-D502	ED-351881	D LED GL-9PR23 RED
5-D503	ED-357691	D LED GL-9HY23 YELLOW
5-D504 to D509	ED-358085	D LED GL-9NG23 GRN
5-D510 to D513	ED-351881	D LED GL-9PR23 RED
5-SW501	ES-347966	SW PUSH ESB-649 01-2-2 N
5-VR501	EV-357689	VR SLIDE 60P2SV0L A503
5-R502, R503	ER-333616	R CB H S15 FS RDS 1/2W 151J
ASSEMBLY BLOCK		
5-D501	ED-351881	D LED GL-9PR23 RED

6. DUBBING PC BOARD

REF. NO.	PART NO.	DESCRIPTION
6-SW401	ES-359242	SW PUSH SUY12A 2-02-02S

7. POWER SW PC BOARD

REF. NO.	PART NO.	DESCRIPTION
7-SW601	ES-358646	SW PUSH SUL121S 1-012-02N

NOTE:
PC PRE AMP BLK consists of following PC BOARDS.

- PRE AMP PC BOARD
- METER PC BOARD
- DUBBING PC BOARD
- POWER SW PC BOARD

ASSEMBLY BLOCK

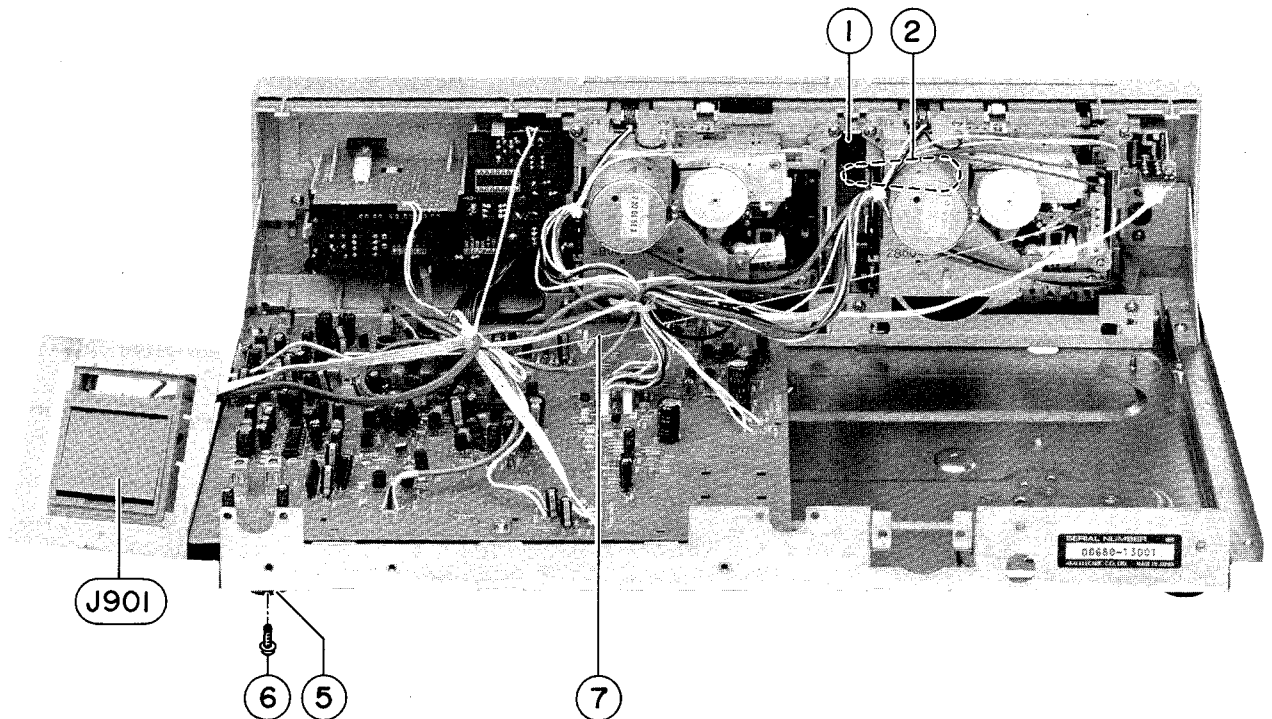

8. ASSEMBLY BLOCK

REF. NO.	PART NO.	DESCRIPTION
8-1	MC-358569	COUNTER MMP382-016
8-2	MB-355124	BELT COUNTER
8-3x	ZG-336615	SP PLATE CASSETTE HOLDER (B)
8-4x	ZG-360733	SP TORSION LID
8-5	SA-202118	FOOT
8-6	ZS-351186	ST BR30X08STL CMT C080
8-7	TC-355519	JOINT REC (B)
8-8x	SP-355163F	PANEL REAR HX-A300W
8-9x	ZS-358803	ST BR30X08STL BNI C080 [PANEL REAR FIX]
8-10x	ZS-320906	ST BR30X06STL CMT [COVER UPPER FIX]
8-J901	EJ-351021	SOCKET CONNECTOR M1701 12P
8-J901B	EJ-356521	SOCKET CONNECTOR-B M1701-A 12P

FINAL ASSEMBLY BLOCK

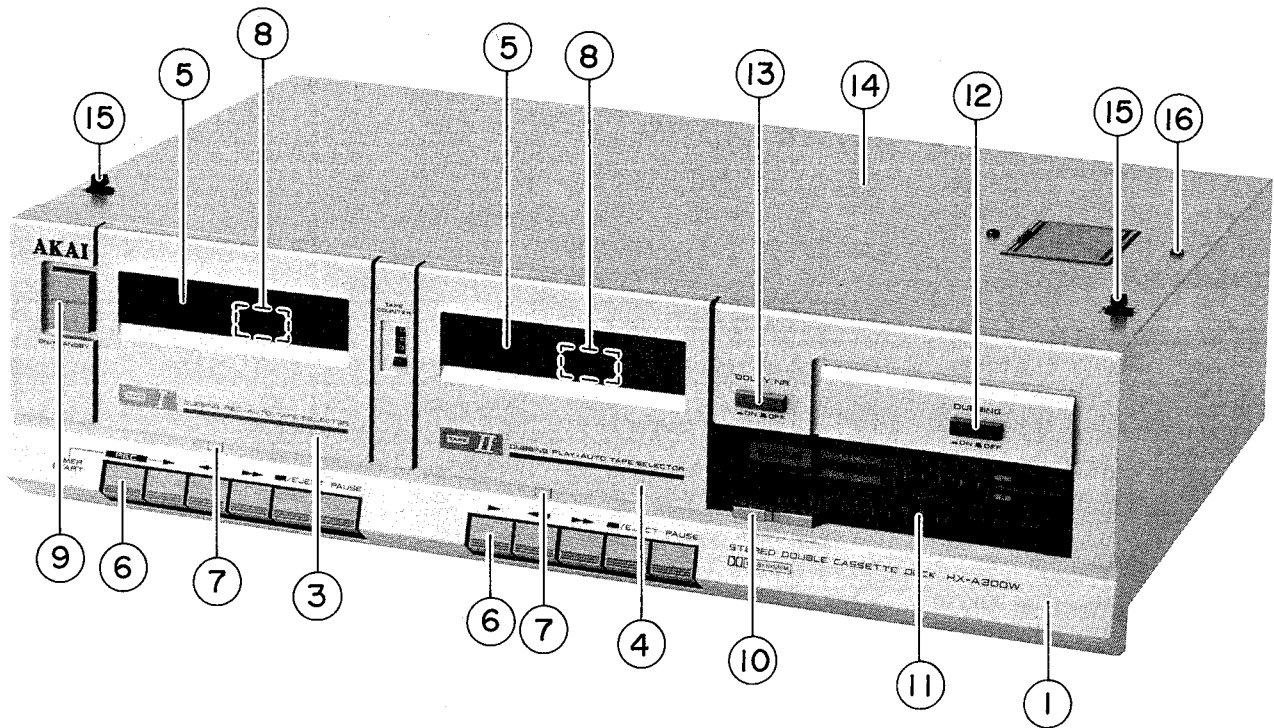

9. FINAL ASSEMBLY BLOCK

REF. NO.	PART NO.	DESCRIPTION
9-1	BD-355164C	PANEL FRONT HX-A300W
9-1B	BD-355164D	PANEL FRONT HX-A300W-B
9-2x	ZS-337783	PT CTS30x08STL CMT [MECHA BLK FIX]
9-3	BD-355128E	LID (3)
9-3B	BD-355128F	LID (3)-B
9-4	BD-355128G	LID (4)
9-4B	BD-355128J	LID (5)-B
9-5	SP-355129	WINDOW LID
9-6	SB-358886A	BUTTON OPERATION
9-7	BC-355156A	COVER AZIMUTH
9-7B	BC-355156B	COVER AZIMUTH-B
9-8	SZ-357722	REFLECTOR
9-9	SK-343017C	KNOB POWER (2)
9-9B	SK-343017F	KNOB POWER-B
9-10	SK-355157A	KNOB REC
9-10B	SK-355157B	KNOB REC-B
9-11	SP-355158	WINDOW METER
9-12	SK-355159A	KNOB PUS H [DUBBING]
9-13	SK-355159B	KNOB PUSH (2) [DOLBY NR]
9-14	SP-355161C	COVER UPPER (2)
9-14B	SP-355161D	COVER UPPER (2)-B
9-15	SZ-359236	CLIP 0816
9-16	ZS-332009	PT BR30x06ST

SYMBOL FOR COLOR VARIATION

NON : STANDARD COLOR
B or BL : BLACK

INDEX

MODEL AP-A100/C

PART NO.	REF. NO.	PART NO.	REF. NO.	PART NO.	REF. NO.	PART NO.	REF. NO.	PART NO.	REF. NO.
Ax-332567C	2-35	EV-315416	1-VR1	SA-332577C	2-25	TP-336361	2-28	ZG-325402	2-6
Ax-332567D	2-35B	EW-358749	2-32A	SK-345362A	2-8	TP-336362	2-28B	ZG-332548	2-17
BC-B332582	2-26	EW-358750	2-32B	SK-345362E	2-8B	TP-345341	2-7	ZG-353257	2-4
BC-358036A	2-1	EW-358754	2-33	SK-351613B	2-34	TP-348266A	2-30A	ZS-350767	2-16
BC-358036B	2-1B	MB-345351B	2-15	SK-351739	2-12	TP-348266B	2-30B	ZS-358930	2-9
BM-354988	2-M901	MB-355119	2-31	TP-B332568X2	2-18	TP-348321	2-29	ZW-270101	2-23
EI-357879	1-IC1	ML-345348	2-21	TP-B345367	2-19	TP-351625	2-3	ZW-340648	2-5
ES-316432	2-SW901	ML-358006	2-13	TP-P1034A040A	2-10	TP-358836	2-2		
ES-358768	1-SW1	MV-269965	2-20	TP-P1034A080A	2-22	ZG-313073	2-24		
EV-315416	1-VR2	MZ-358034	2-14	TP-301300	2-27	ZG-313181	2-11		

MODEL AP-A200

PART NO.	REF. NO.	PART NO.	REF. NO.	PART NO.	REF. NO.	PART NO.	REF. NO.	PART NO.	REF. NO.
AX-332567C	4-30xA	ET-328844	1-Q1	SK-358011A	4-33	ZG-358951	4-3		
AX-332567D	4-30xB	ET-328844	1-Q2	SK-358011B	4-33B	ZG-358952	4-34		
BC-B353247	4-37	ET-330225	1-Q10	SP-359109	4-35	ZS-310984	4-12		
BC-353231F	4-1B	ET-330225	1-Q7	TP-B332568X2	4-21	ZS-332009	4-36		
BD-P1047A020A	4-31	ET-330225	1-Q8	TP-B358014	4-39	ZS-349118	4-19		
BD-P1047A020B	4-31B	ET-742510	1-Q11	TP-P1034A080A	4-25	ZS-358930	4-10		
BD-353231D	4-1	ET-742510	1-Q4	TP-P1037A040A	4-9	ZW-290283	4-26		
BM-360085	4-M901	ET-742510	1-Q3	TP-348266A	4-40B	ZW-325521	4-8		
ED-337391	3-D1	EV-780138	1-VR1	TP-348266B	4-40A	ZW-331536	4-14		
ED-349656	3-D2	EW-358749	4-42B	TP-353252	4-7	ZW-340648	4-6		
ED-557447	2-D1	EW-358750	4-42A	TP-353712	4-18	ZW-340648	4-11		
ED-557447	2-D2	EW-358754	4-41	TP-358003	4-16	ZW-382083	4-15		
ED-708712	1-D1	MB-343057	4-38	TP-358012A	4-29				
EI-780137	1-IC1	ML-345348	4-24	TP-358012B	4-29B				
ER-353877	1-R1	ML-358006	4-17	TP-358836	4-2				
ES-325488	4-SW901	MS-353238	4-4	TP-360072	4-22				
ES-337843	2-SW1	MV-269965	4-23	ZG-313073	4-27				
ET-308867	1-Q5	SA-332577	4-28	ZG-332548	4-20				
ET-308867	1-Q9	SK-358010A	4-32	ZG-353257	4-5				
ET-308867	1-Q6	SK-358010B	4-32B	ZG-358000	4-13				

MODEL AT-A200/L

PART NO.	REF. NO.	PART NO.	REF. NO.	PART NO.	REF. NO.	PART NO.	REF. NO.	PART NO.	REF. NO.
BA-A3052A020A	1-3A	ED-301911	4-D9	EM-353670	4-IN1	ET-337759	2-TR2		
BA-A3052A020B	1-3B	ED-301911	4-D10	EO-336829	2-T3	ET-338410	2-TR4		
BA-A3052A020C	1-3C	ED-301911	4-D12	EO-337523	2-L1	ET-338410	2-TR6		
BA-A3052A020D	1-3D	ED-301911	4-D13	EO-337523	2-L2	ET-349081	2-TR20		
BA-A3052A020E	1-3E	ED-301911	4-D14	EO-337598	2-T1	ET-349081	2-TR21		
BA-A3052A020F	1-3F	ED-301911	4-D1	EO-337599	2-T2	ET-349081	2-TR3		
BA-A3052A030A	1-1A	ED-301911	4-D3	EO-337640	3-T1	ET-349081	2-TR18		
BA-A3052A030B	1-1B	ED-301911	4-D2	EO-349461	3-L1	ET-349081	2-TR17		
BA-A3052A030C	1-1C	ED-301911	4-D4	EO-349461	3-L3	ET-349081	2-TR19		
BA-A3052A030D	1-1D	ED-301911	4-D5	EO-349462	3-L4	ET-351853	2-TR13		
BA-A3052A030E	1-1E	ED-306316	2-D1	EO-349462	3-L2	ET-351853	2-TR11		
BA-A3052A030G	1-1G	ED-321269	4-D15	EO-349462	3-L5	ET-351853	3-TR4		
BA-A3052A030F	1-1F	ED-337265	2-D7	EO-353687	3-L7A	ET-351853	3-TR1		
BA-F0141A010A	1-2A	ED-344280	2-D4	EO-356732	2-T6	ET-352408	2-TR5		
BA-F0141A010B	1-2B	ED-344280	2-D5	EO-359056	3-L6	ET-353366	2-TR16		
BA-F0141A010C	1-2C	ED-344280	2-D6	EO-359062	2-T4	ET-353366	2-TR15		
BC-358993A	8-5	ED-344280	2-D11	EO-359063	2-T5	ET-353898	2-TR7		
BC-358993G	8-5B	ED-344280	4-D8	EO-361840	3-L7B	ET-353898	2-TR10		
BD-A3052A050A	8-1A	ED-344280	4-D11	ER-306805	2-R6	ET-353898	2-TR23		
BD-A3052A050B	8-1B	ED-349448	3-D1	ER-327710	2-R7	ET-353898	2-TR14		
BD-A3052A050C	8-1C	ED-349448	3-D2	ER-328067	2-R64	ET-353898	2-TR22		
BD-A3052A050D	8-1D	ED-349448	3-D3	ER-360146	2-R47	ET-353899	2-TR8		
BD-388978A	8-3	ED-349448	3-D4	ER-360146	2-R8	ET-353899	2-TR9		
BD-358978B	8-3B	ED-349460	2-D2	ES-344445	2-SW1	ET-353899	4-TR1		
BD-358979A	8-4	ED-349460	2-D3	ES-349367	4-SW10	EV-356577	2-VR1		
BD-358979B	8-4B	EE-359265	7-5	ES-349367	4-SW1	EV-356579	2-VR2		
EC-344483	2-C51	EH-336804	2-FL3	ES-349367	4-SW3	EW-359171	7-7		
EC-346879	2-C18	EH-355382	2-FL4	ES-349367	4-SW7	SK-343017C	8-2		
EC-347591	2-C7	EH-355568	2-FL1	ES-349367	4-SW9	SK-343017F	8-2B		
EC-353044	2-C17B	EH-355568	2-FL2	ES-349367	4-SW2	SP-358980A	7-1A		
EC-356597	2-C17A	EH-359049	4-IB1	ES-349367	4-SW8	SP-358980B	7-1B		
EC-356598	2-C62	EI-344422	2-X1	ES-349367	4-SW6	SP-358980E	7-1C		
EC-356598	2-C63	EI-348409	4-X1	ES-349367	4-SW5	SZ-332739	7-2		
EC-359065	2-VC2	EI-354951	2-IC1	ES-349367	4-SW4	ZS-359179	7-3		
EC-359065	2-VC1	EI-359048	4-IC1	ES-359172	5-SW11	ES-359226	7-4		
ED-301911	2-D8	EI-359060	2-IC2	ET-360115	2-SW2				
ED-301911	2-D9	EI-359061	2-IC3	ET-328265	2-TR1				
ED-301911	2-D10	EJ-352118	7-6x	ET-328265	2-TR12				
ED-301911	4-D6	EJ-356522	6-P1	ET-328265	3-TR3				
ED-301911	4-D7	EJ-359031	2-TM1	ET-336869	3-TR2				

INDEX

MODEL AM-A200

PART NO.	REF. NO.	PART NO.	REF. NO.	PART NO.	REF. NO.	PART NO.	REF. NO.	PART NO.	REF. NO.
BA-A2043A020A	1-2A	ED-337391	6-D7	EJ-356522	9-P901	ET-353899	4-TR105		
BA-A2043A020B	1-2B	ED-337391	6-D8	EJ-359067	2-J2	ET-355216	2-TR1		
BA-A2043A020C	1-2C	ED-346603	2-D3	EJ-359178	2-P1	ET-360137	4-TR106		
BA-A2043A040A	1-1A	ED-346603	2-D4	EJ-359222	5-J201	ET-360137	4-TR107		
BA-A2043A040B	1-1B	ED-346616	4-D105	EO-318635	2-L1	EV-359083	3-VR1		
BC-358993C	11-10	ED-346617	4-D106	EO-337880	4-L101	EV-359219	3-VR2		
BC-358993H	11-10B	ED-348200	4-D112	EO-338409	5-L201	EV-359219	3-VR3		
BD-A2043A050A	11-1	ED-357754	2-D1	EO-342936	5-L202	EV-359219	3-VR4		
BD-A2043A050B	11-1B	ED-357754	2-D9	EO-342936	5-L203	EV-359219	3-VR5		
BD-358994A	11-7	EF-306952	4-F6A	ER-200595	4-FR2	EV-359219	3-VR6		
BD-358994B	11-7B	EF-306952	4-F7A	ER-200595	4-FR1	EV-359219	3-VR7		
BD-358995A	11-8	EF-306957	4-F3A	ER-322591	4-R121	EV-359219	3-VR8		
BD-358995B	11-8B	EF-306957	4-F4A	ER-322591	4-R122	EV-359219	3-VR9		
BT-359193	10-T901A	EF-306957	4-F6B	ER-324480	4-R107	EV-359219	3-VR10		
BT-359194	10-T901B	EF-306957	4-F7B	ER-324480	4-R108	EV-359220	7-VR11		
BT-359195	10-T901C	EF-308847	4-F5A	ER-356573	5-R201	EW-359076	10-3A		
BT-359196	10-T901D	EF-311839	5-F1A	ER-359268	5-R202	EW-359077	103B		
BT-359197	10-T901E	EF-311839	5-F2	ER-359269	4-R116	EW-359078	10-3C		
EC-314688	5-C201B	EF-323080	5-F1B	ER-359351	4-R112	EW-359079	10-3D		
EC-320548	5-C201A	EF-359007	4-F5C	ER-359351	4-R111	EW-359081	10-3F		
EC-323846	4-C114	EF-359007	5-F1D	ES-337902	5-SW201	EW-359204	10-3E		
EC-326583	4-C118	EF-359086	4-F3C	ES-349070	10-VS901	SB-358882	11-4		
EC-338496	5-C201C	EF-359086	4-F4C	ES-359218	2-SW1	SB-358882B	11-5		
EC-360113	4-C116	EF-359225	4-F6D	ES-359961	5-SW202	SK-B358605X2	11-6		
EC-360113	4-C117	EF-359225	4-F7D	ET-322598	4-TR104	SK-B358605X2	11-6B		
ED-320213	4-D113	EF-602550	4-F5B	ET-338565	2-TR8	SK-343017C	11-2		
ED-301911	2-D2	EF-602550	5-F1C	ET-349459	4-TR101	SK-343017F	11-2B		
ED-301911	4-D114	EF-690996	4-F3B	ET-349459	4-TR102	SK-358879	11-3		
ED-301911	4-D115	EF-690996	4-F4B	ET-349459	4-TR103	SP-358990A	10-1C		
ED-301911	4-D116	EF-691007	4-F6C	ET-353898	2-TR3	SP-358990B	10-1D		
ED-301911	4-D101	EF-691007	4-F7C	ET-353898	2-TR4	SP-158990C	10-1B		
ED-301911	4-D108	EI-352259	2-IC2	ET-353898	2-TR5	SP-358990E	10-1A		
ED-301911	4-D109	EI-357228	2-IC3	ET-353898	2-TR6	ZS-322580	10-2		
ED-302269	4-D111	EI-346071	2-IC1	ET-353898	2-TR7	ZS-359179	11-9		
ED-319176	4-D104	EI-358554	4-IC101	ET-353898	2-TR8	ZS-359226	11-11		
ED-322046	4-D110	EI-359221	3-IC4	ET-353898	2-TR9				
ED-329056	4-D102	EI-359221	3-IC5	ET-353898	2-TR10				
ED-337265	4-D103	EJ-336905	2-J1	ET-353898	2-TR11				
ED-337391	6-D5	EJ-349061	5-TM201	ET-353898	2-TR12				
ED-337391	6-D6	EJ-356521	8-J901	ET-353899	2-TR2				

PART NO.	REF. NO.	PART NO.	REF. NO.	PART NO.	REF. NO.	PART NO.	REF. NO.	PART NO.	REF. NO.
BA-T2085A020A	2-1	ED-344280	3-D203	ET-360137	3-TR212	MZ-716171	1-26	ZS-536488	1-112
BB-359082	1-1	EH-351182	3-FL201	ET-360137	3-TR212	MZ-749256	1-34	ZS-716355	1-81
BC-358993E	8-11	EI-345551	4-IC101	EV-356582	3-VR201	SB-358882	8-4	ZS-749292	1-113
BC-358993J	8-11B	EI-349591	3-IC201	EV-356582	3-VR202	SB-716278	1-41	ZS-749293	1-114
BD-358994A	8-6	EJ-356521	7-J901	EV-356582	3-VR203	SK-343017C	8-2	ZW-716181	1-52
BD-358994B	8-6B	EO-349589	3-T201	HE-337047	1-H902	SK-343017F	8-2B		
BD-358995A	8-7	EL-356809	3-FL202	HP-712824	1-H901	SB-358886A	8-5		
BD-358995B	8-7B	EO-357050	3-L201	HZ-716172	1-27	SK-359001A	8-3		
BD-358999A	8-1	ES-359071	3-SW203	MB-351605	7-2	SK-359001B	8-3B		
BD-358999B	8-1B	ES-359189	3-SW201	MB-712818	1-57	SP-359004	7-1		
BD-359000A	8-8	ES-362082	3-SW202	MB-712819	1-58	TC-712810	1-43		
BD-359000B	8-8B	ES-359192	5-SW204	MB-712820	1-59	TC-712811	1-44		
BF-712807	1-37	ES-713179	1-SW902	MC-353312	7-5	TC-712823	1-85		
BL-712799	1-28	ES-716377	1-SW901	MI-711710	1-35	ZG-359249	7-3		
BM-712825	1-M901	ET-308977	3-TR208	MI-712804	1-33	ZG-712816	1-53		
BR-715918	1-29	ET-308977	3-TR209	MI-712812	1-46	ZG-712822	1-79		
BR-715919	1-30	ET-310148	3-TR211	MI-712812	1-47	ZG-715921	1-73		
EC-326138	3-C237	ET-344275	3-TR201	MI-712812	1-48	ZG-715922	1-128		
EC-347263	3-C232	ET-349081	3-TR205	MI-712817	1-56	ZG-715940	1-75		
ED-321269	4-D5	ET-349081	3-TR206	MI-715920	1-49	ZG-716187	1-67		
ED-321269	6-D207	ET-349081	3-TR207	MI-715935	1-32	ZG-716188	1-68		
ED-324014	3-D205	ET-349081	3-TR204	ML-712806	1-36	ZG-716189	1-69		
ED-330996	4-D4	ET-349081	3-TR214	ML-712809	1-40	ZG-716190	1-70		
ED-330996	4-D3	ET-349081	3-TR215	ML-716175	1-38	ZG-716193	1-78		
ED-331617	3-D204	ET-349081	3-TR203	ML-716179	1-50	ZG-716194	1-80		
ED-337391	4-D1	ET-349366	3-TR213	ML-716180	1-51	ZG-716197	1-82		
ED-337391	4-D2	ET-349366	3-TR217	ML-716375	1-24	ZG-749268	1-72		
ED-337391	6-D208	ET-349366	3-TR216	MV-716186	1-60	ZS-309315	7-6		
ED-344280	3-D201	ET-350795	3-TR202	MZ-359250	7-4	ZS-359179	8-9		
ED-344280	3-D202	ET-360137	3-TR210	MZ-712808	1-39	ZS-359702	8-10		

INDEX

MODEL HX-A300W

PART NO.	REF. NO.	PART NO.	REF. NO.	PART NO.	REF. NO.	PART NO.	REF. NO.	PART NO.	REF. NO.
BA-T2 086A020A	3-1	ED-357691	5-D503	ET-349705	4-TR205	MI-715920	2-49	ZG-715921	2-73
BB-355186	1-1	ED-358085	5-D504	ET-349705	4-TR206	MI-715935	1-32	ZG-715922	1-128
BB-355187	2-1	ED-358085	5-D505	ET-349705	4-TR211	MI-715935	2-32	ZG-715922	2-128
BC-355156A	9-7	ED-358085	5-D507	ET-349705	4-TR212	ML-712806	1-36	ZG-715940	1-75
BA-A3052A020F	1-3F	ED-358085	5-D509	ET-349705	4-TR213	ML-712809	1-40	ZG-715940	2-75
BC-355156B	9-7B	ED-358085	5-D508	ET-349705	4-TR217	ML-712809	2-40	ZG-716187	1-67
BD-355128E	9-3	ED-358085	5-D506	ET-349705	4-TR303	ML-716175	1-38	ZG-716188	1-68
BD-355128F	9-3B	EH-336776	4-FL101	ET-349705	4-TR306	ML-716179	1-50	ZG-716988	2-68
BD-355128G	9-4	EH-336776	4-FR201	ET-349705	4-TR310	ML-716979	2-50	ZG-716189	1-69
BD-355128J	9-4B	EI-337228	4-IC303	ET-349705	4-TR314	ML-716180	1-51	ZG-716189	2-69
BD-355164C	9-1	EI-347634	4-IC304	ET-349705	4-TR214	ML-716180	2-51	ZG-716190	1-70
BD-355164D	9-1B	EI-349590	4-IC301	ET-349705	4-TR207	ML-716375	1-24	ZG-716190	2-70
BF-712807	1-37	EI-349590	4-IC302	ET-349705	4-TR117	ML-716375	2-24	ZG-716193	1-78
BF-712807	2-37	EI-355388	5-IC501	ET-349705	4-TR308	MS-715941	2-93	ZG-716193	2-78
BL-712799	1-28	EJ-351021	8-J901	ET-349705	4-TR111	MZ-712808	1-39	ZG-716194	1-80
BL-712799	2-28	EJ-356521	8-J901B	EV-356581	4-VR102	MZ-712808	2-39	ZG-716194	2-80
BM-721825	1-M901	EO-348235	4-L101	EV-356581	4-VR201	MZ-716171	1-26	ZG-716197	1-82
BM-712825	2-M901	EO-348235	4-L201	VE-356581	4-VR202	MZ-716171	2-26	ZG-716197	2-82
BR-715918	1-29	EO-353311	4-T301	EV-356581	4-VR101	MZ-716577	1-60	ZG-716578	1-76
BR-715918	2-29	EO-356809	4-FL102	EV-357619	4-VR104	MZ-716577	2-60	ZG-716578	2-76
BR-715919	1-30	EO-356809	4-FL202	EV-357619	4-VR204	MZ-716582	2-22	ZG-716579	1-77
BR-715919	2-30	ER-318647	4-FR301	EV-357689	5-VR501	MZ-749256	1-34	ZG-716579	2-77
EC-334068	4-C102	ER-333616	5-R502	EV-358829	4-VR103	MZ-749256	2-34	ZG-749268	1-72
EC-334068	4-C110	ER-333616	5-R503	EV-358829	4-VR203	SA-202118	8-5	ZG-749268	2-72
EC-334068	4-C202	ES-347966	5-SW501	HE-337047	1-H902	SB-716178	1-41	ZS-320906	8-10x
EC-334068	4-C210	ES-358580	4-SW301	HP-712824	1-H901	SB-716178	2-41	ZS-332009	9-16
EC-345817	4-C309	ES-358646	7-SW601	HP-712824	2-H901	SK-343017C	9-9	ZS-337783	9-2
EC-347228	4-C146	ES-359242	6-SW401	HZ-716172	1-27	SK-343017F	9-9B	ZS-351186	8-6
EC-347228	4-C246	ES-713179	1-SW902	HZ-716172	2-27	SK-355157A	9-10	ZS-358803	8-9x
ED-324014	4-D303	ES-715944	1-SW901	MB-355124	8-2	SK-355157B	9-10B	ZS-536488	1-112
ED-344280	4-D305	ES-715944	2-SW901	MB-712818	1-57	SK-355159A	9-12	ZS-536488	2-112
ED-344280	4-D306	ES-715945	1-SW903	MB-712818	2-57	SK-355159B	9-13	ZS-715982	1-87
ED-344280	4-D307	ES-715945	2-SW903	MB-712819	1-58	SB-358886A	9-6	ZS-715982	2-87
ED-344280	4-D308	ET-308472	4-TR311	MB-712819	2-58	SP-355129	9-5	ZS-716203	1-88
ED-344280	4-D310	ET-308977	4-TR301	MB-712820	1-59	SP-355158	9-11	ZS-716203	2-88
ED-344280	4-D311	ET-308977	4-TR302	MB-712820	2-59	SP-355161C	9-14	ZS-716204	1-89
ED-344280	4-D317	ET-348931	4-TR309	MC-358569	8-1	SP-355161D	9-14B	ZS-716204	2-89
ED-344280	4-D318	ET-349272	4-TR304	MC-711710	1-35	SP-355163F	8-8x	ZS-716355	1-81
ED-344280	4-D319	ET-349366	4-TR305	MI-711710	2-35	SK-355157A	9-8	ZS-716355	2-81
ED-344280	4-D321	ET-349366	4-TR318	MI-712804	1-33	SZ-359236	9-15	ZS-716576	2-118
ED-344280	4-D322	ET-349366	4-TR319	MI-712804	2-33	TC-355519	8-7	ZS-716580	1-91
ED-348014	4-D320	ET-349366	4-TR320	MI-712812	1-46	TC-712811	1-44	ZS-716580	2-91
ED-349662	4-D304	ET-349705	4-TR103	MI-712812	2-46	TC-712811	2-44	ZS-749292	1-113
ED-349662	4-D316	ET-349705	4-TR105	MI-712813	1-47	TC-712823	1-85	ZS-749292	2-113
ED-351881	5-D502	ET-349705	4-TR106	MI-712813	2-47	TC-712823	2-85	ZS-749293	1-114
ED-351881	5-D510	ET-349705	4-TR107	MI-712814	1-48	ZG-336615	8-3x	ZS-749293	2-114
ED-351881	5-D511	ET-349705	4-TR112	MI-712814	2-48	ZG-360733	8-4x	ZW-716181	1-52
ED-351881	5-D512	ET-349705	4-TR113	MI-712817	1-56	ZG-712822	1-79	ZW-716181	2-52
ED-351881	5-D513	ET-349705	4-TR114	MI-712817	2-56	ZG-712822	2-79		
ED-351881	5-D501	ET-349705	4-TR203	MI-715920	1-49	ZG-715921	1-73		

AKAI

PRO-A200D/A200WD

MODEL AP-A100/C, AP-A200/C, AT-A200/L,
AM-A200, HX-A200, HX-A300W

SCHEMATIC DIAGRAM AND PC BOARD

TABLE OF CONTENTS

1. BLOCK DIAGRAM OF IC'S	2
2. AP-A100/C SCHEMATIC DIAGRAM, AP-A200 SCHEMATIC DIAGRAM, HALL D. D MOTOR, JUNCTION PCB, LED PCB, MOTOR PCB, SPEED SELECTOR PCB	3
3. AT-A200 SCHEMATIC DIAGRAM	4
4. CONNECTOR PCB, CONTROL PCB, FRONT END PCB, POWER SW PCB, TUNER PCB	5
5. AT-200L SCHEMATIC DIAGRAM	6
6. CONNECTOR PCB, CONTROL PCB, FRONT END PCB, POWER SW PCB, TUNER PCB	7
7. AM-A200 SCHEMATIC DIAGRAM	8
8. AM-A200 BLOCK DIAGRAM, CONNECTOR PCB, GRAPHIC EQ PCB, LED PCB, MAIN AMP PCB, POWER SUPPLY PCB	9
9. HX-A200 SCHEMATIC DIAGRAM	10
10. CONNECTOR PCB, LED PCB, LEVEL METER PCB, PRE AMP (A) PCB, STAND BY SW PCB	11
11. HX-A300W SCHEMATIC DIAGRAM	12
12. CONNECTOR PCB, DUBBING PCB, METER PCB, POWER SW PCB, PRE AMP PCB	13
13. HX-A300W BLOCK DIAGRAM	14

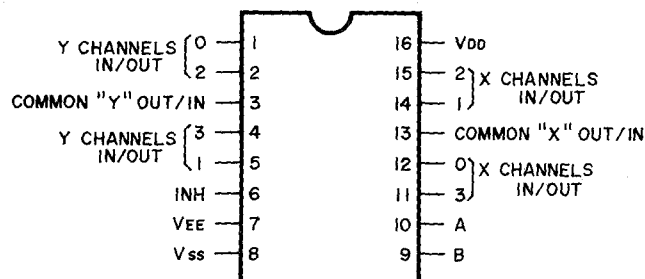
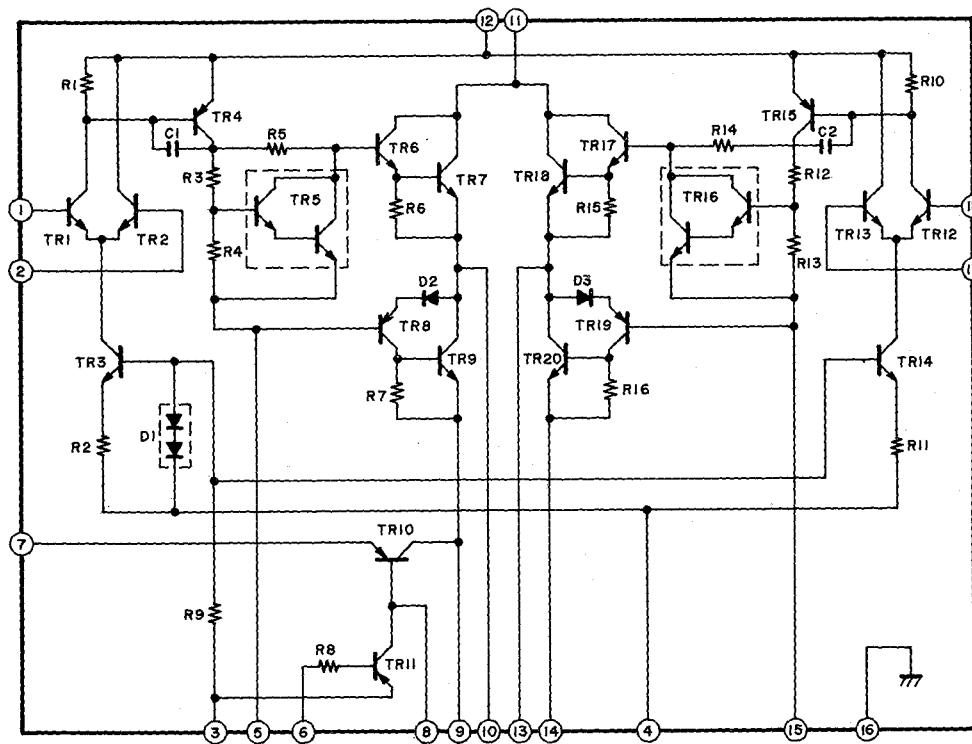
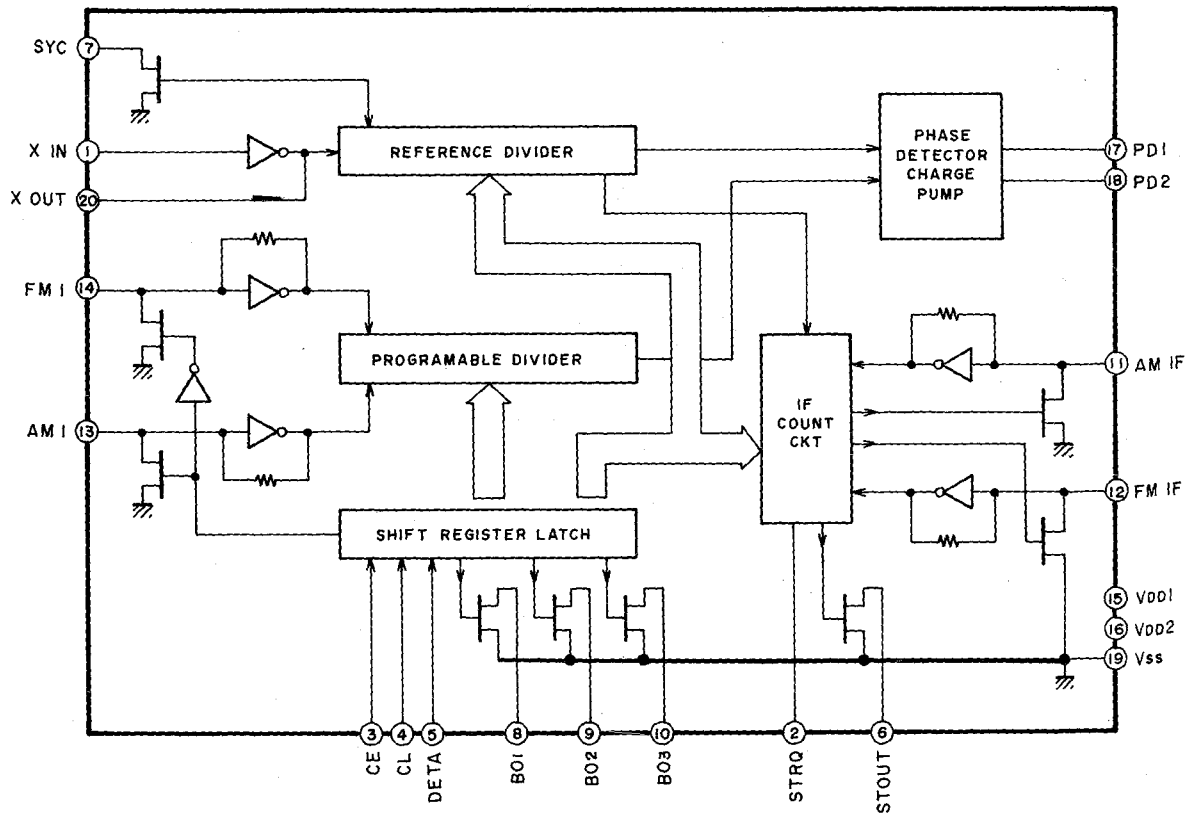

INHIBIT ⑥	A ⑩	B ⑨	"ON" CHANNEL
L	L	L	0X, 0Y
L	H	L	1X, 1Y
L	L	H	2X, 2Y
L	H	H	3X, 3Y
H	X	X	NONE

X=DON'T CARE

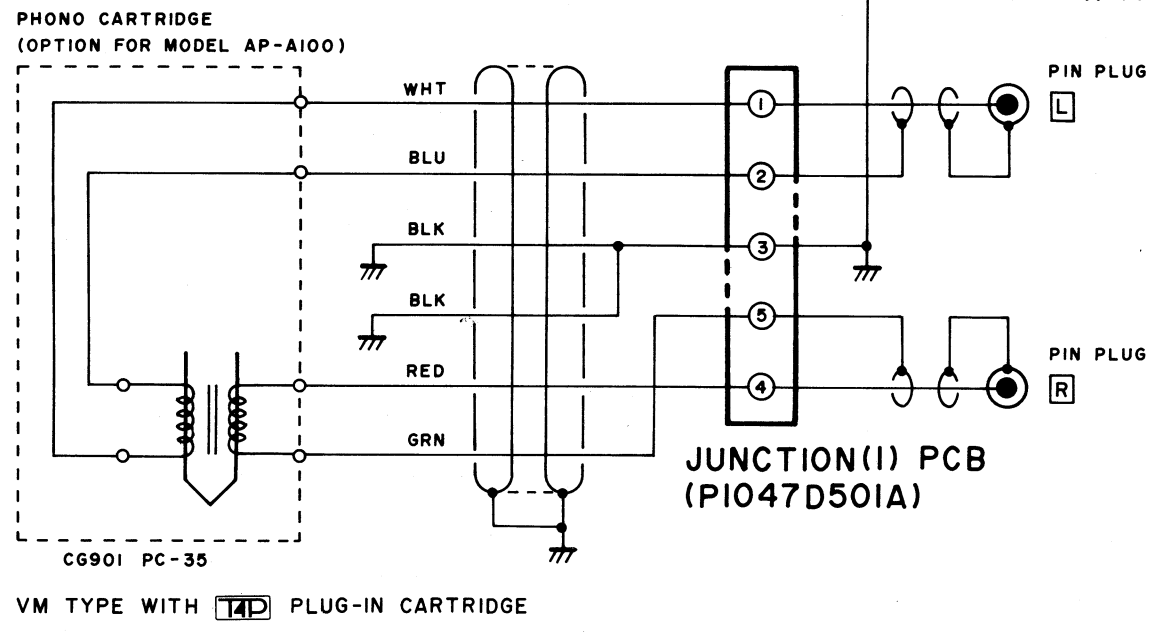
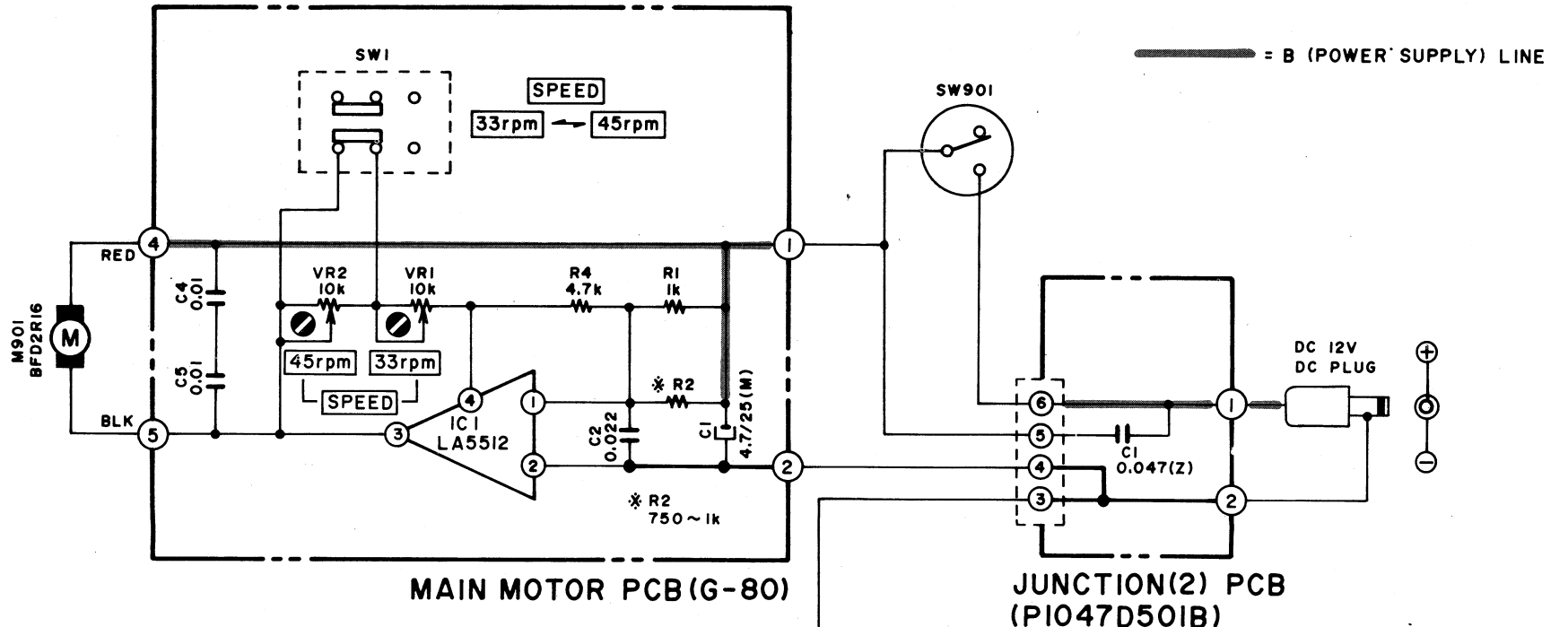

NOTE
UNLESS OTHERWISE SPECIFIED
ALL RESISTORS IN OHMS 1/4W(J)
ALL CAPACITORS IN μ F 50WV(J)
POWER TRANSFORMER IS DIFFERENT
ACCORDING TO AREA

AP-A100/C
SCHEMATIC DIAGRAM
No. 850614A_{A4}

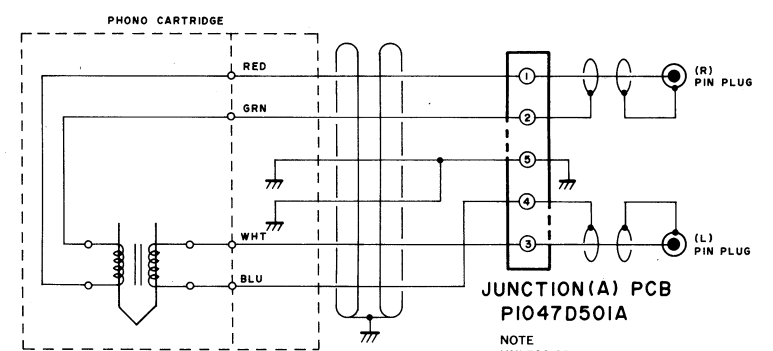
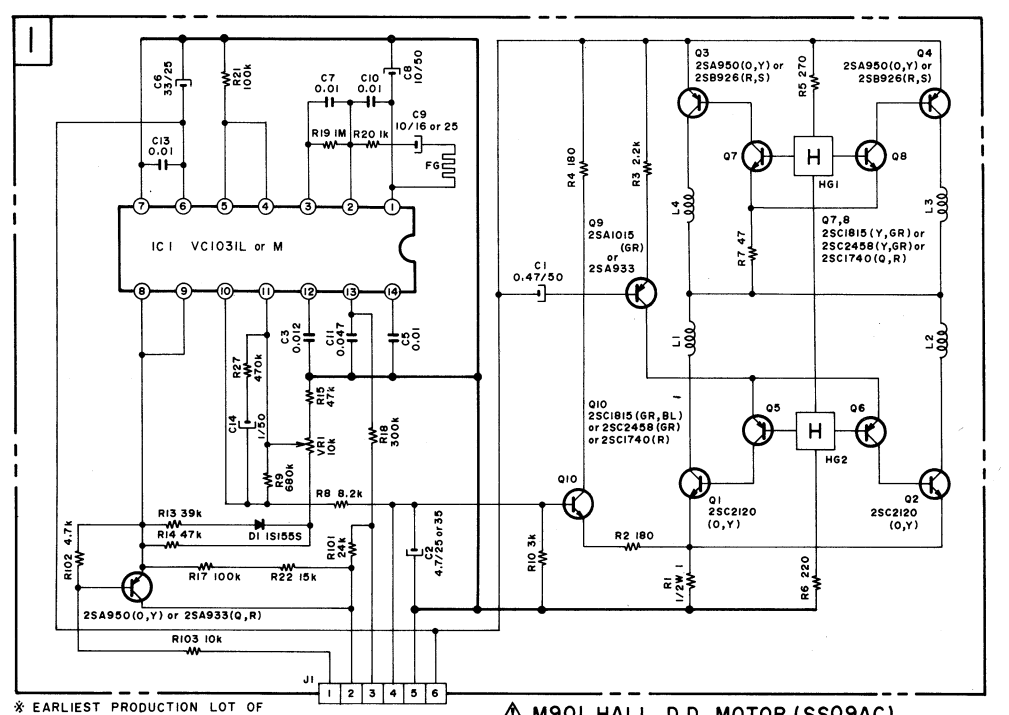
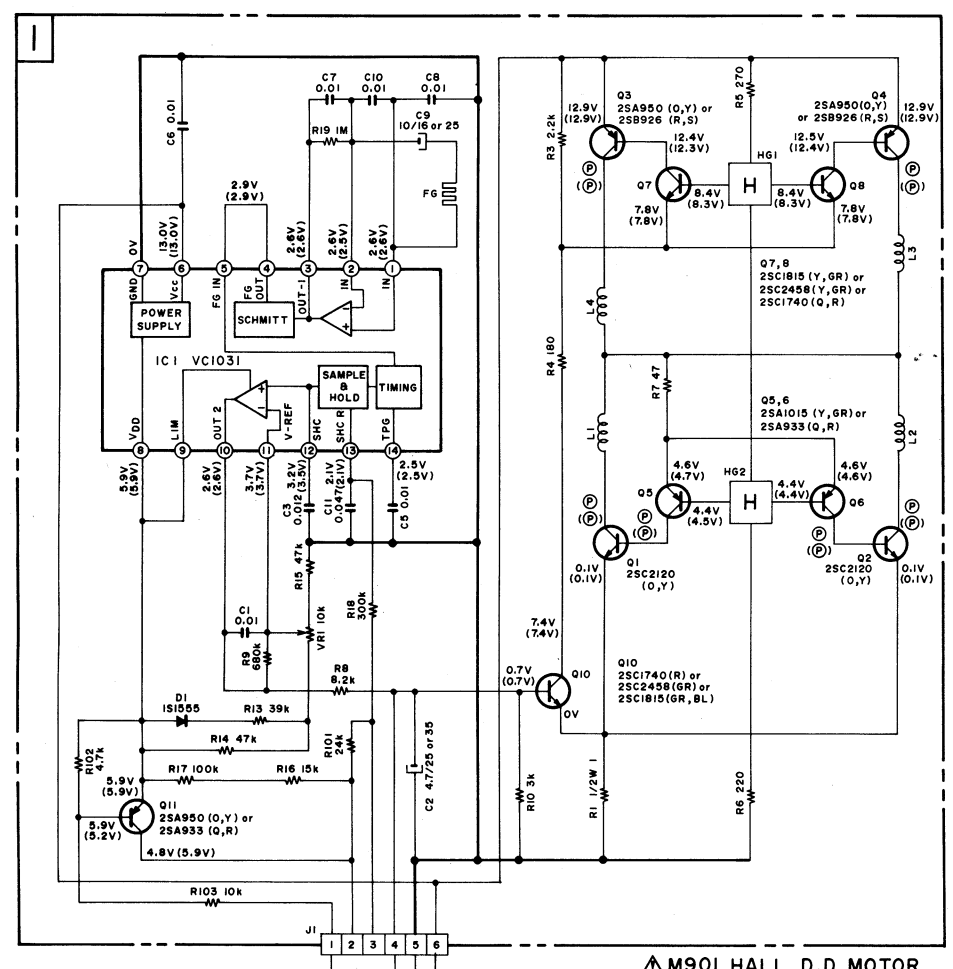

NOTE
UNLESS OTHERWISE SPECIFIED
ALL RESISTORS IN OHMS 1/4W(J)
ALL CAPACITORS IN μ F 50WV(J)
POWER TRANSFORMER IS DIFFERENT
ACCORDING TO AREA

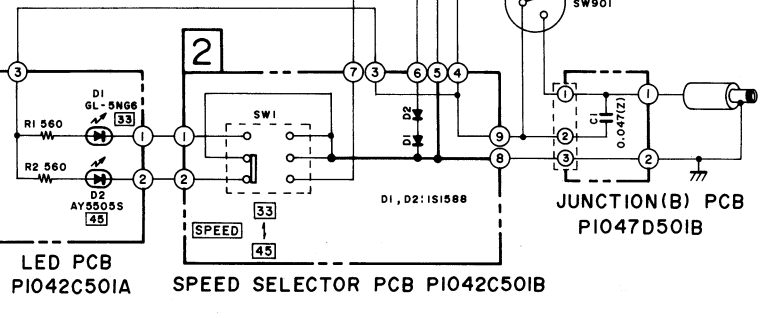

INDICATED VOLTAGES ARE AT 33rpm PLAY MODE AND INDICATED IN () AT 45rpm PLAY MODE

AP-A200
SCHEMATIC DIAGRAM
No. 850608A_{A2}

= B (POWER SUPPLY) LINE

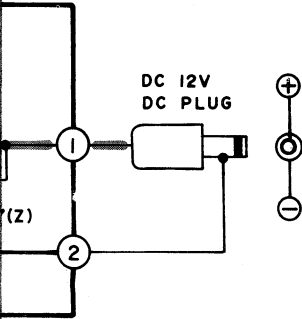

(2) PCB
PI047D501B

NOTE
UNLESS OTHERWISE SPECIFIED
ALL RESISTORS IN OHMS 1/4W(J)
ALL CAPACITORS IN μ F 50WV(J)
POWER TRANSFORMER IS DIFFERENT
ACCORDING TO AREA

AP-100/C
SCHEMATIC DIAGRAM
No. 850614A_{A4}
3

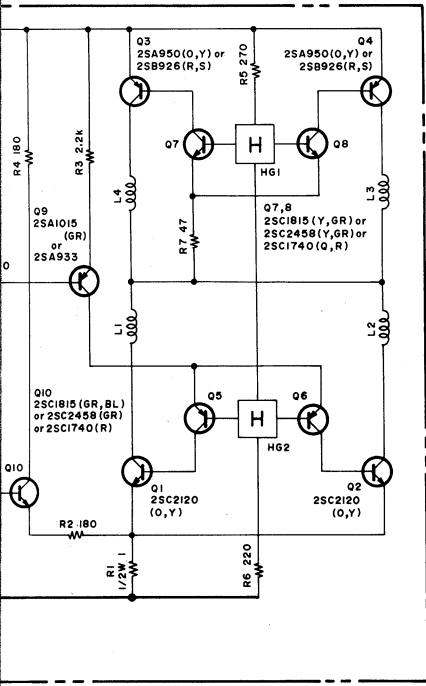

901 HALL D.D MOTOR (SS09AC)

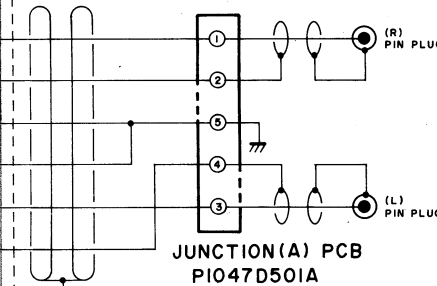

JUNCTION (A) PCB
PI047D501A

NOTE
UNLESS OTHERWISE SPECIFIED
ALL RESISTORS IN OHMS 1/4W(J)
ALL CAPACITORS IN μ F 50WV(J)
POWER TRANSFORMER IS DIFFERENT
ACCORDING TO AREA

AP-A200
SCHEMATIC DIAGRAM
No. 850608A_{A2}
2

- Q1, 2 ---- 2SC2120(O, Y)
- Q3, 4 ---- 2SA950(O, Y) or 2SB926(R, S)
- Q5, 6 ---- 2SA1015(Y, GR) or 2SA933(Q, R)
- Q7, 8, 10 --- 2SC1815(Y, GR) or 2SC2458(Y, GR) or 2SC1740(Q, R)
- Q11 ---- 2SA950(O, Y) or 2SA933(Q, R)

- = NPN TRANSISTOR
- = PNP TRANSISTOR

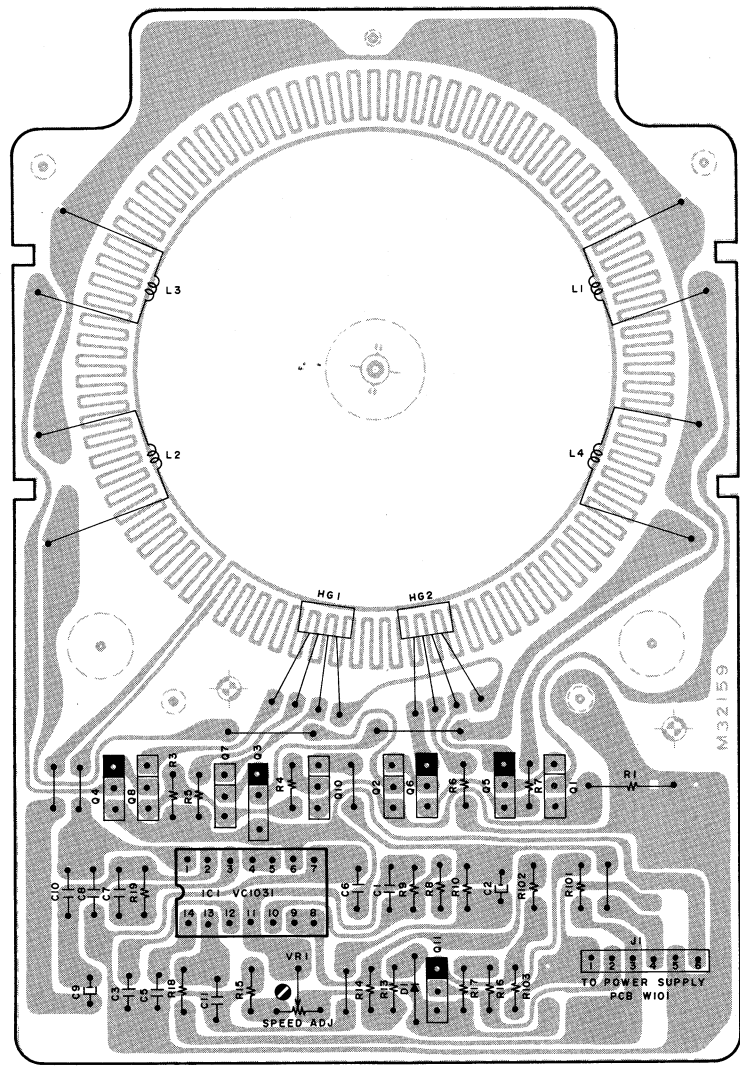

HALL D.D MOTOR M901 SS09DA

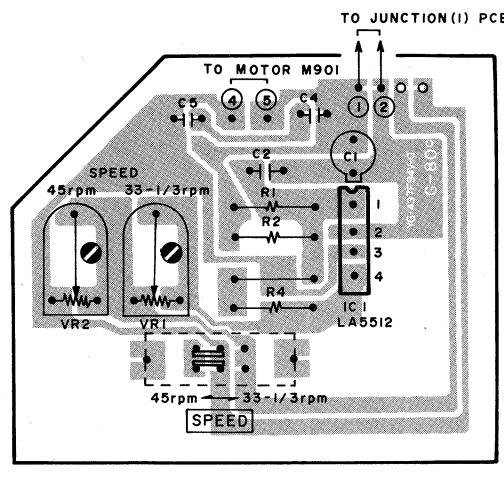

MOTOR PCB

JUNCTION (2) PCB
PI047D501A

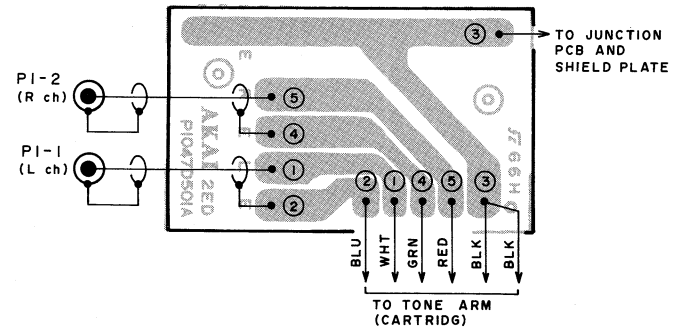

JUNCTION (1) PCB
PI047D501B

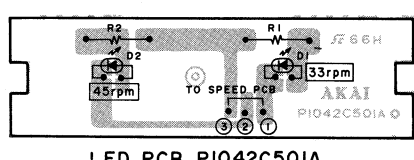
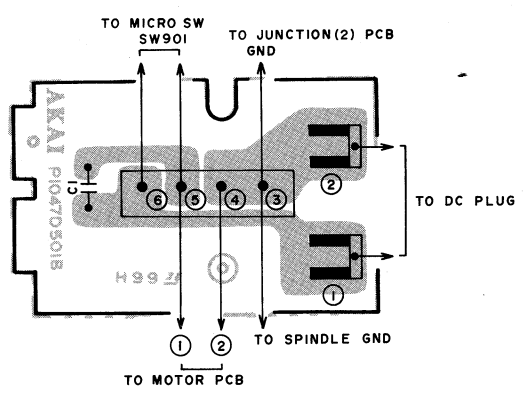

LED PCB PI042C501A

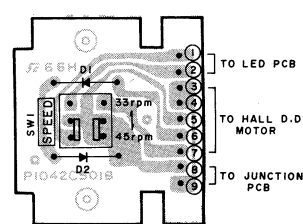

SPEED SELECTOR PCB
PI042C501B

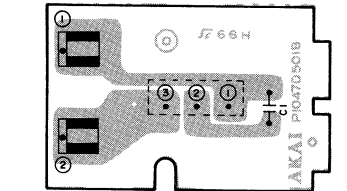

JUNCTION (B) PCB PI047D501B

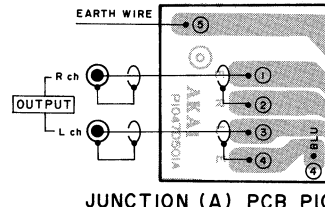

JUNCTION (A) PCB PI047D501A

WARNING: Δ INDICATES SAFETY CRITICAL COMPONENTS. FOR CONTINUED SAFETY, REPLACE SAFETY CRITICAL COMPONENTS ONLY WITH MANUFACTURER'S RECOMMENDED PARTS.
AVERTISSEMENT: Δ IL INDIQUE LES COMPOSANTS CRITIQUES DE SÉCURITÉ. POUR MAINTENIR LE DEGRÉ DE SÉCURITÉ DE L'APPAREIL, NE REMPLACER QUE DES PIÈCES RECOMMANDÉES PAR LE FABRICANT.

AT-A200

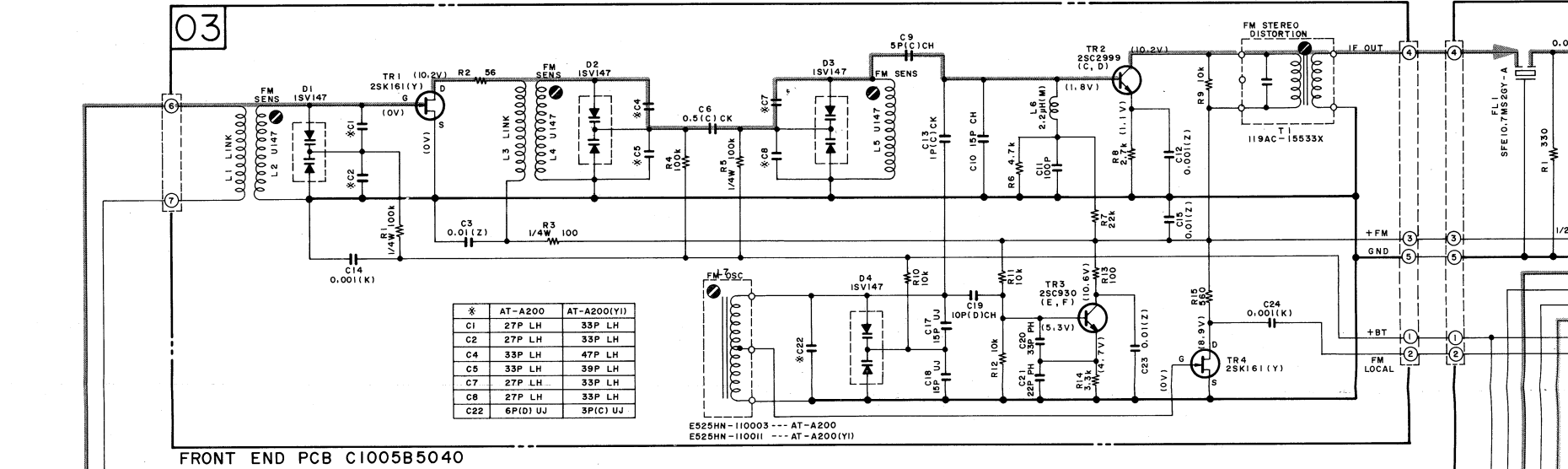

	AT-A200	AT-A200(Y)
C1	27P LH	33P LH
C2	27P LH	33P LH
C4	33P LH	47P LH
C5	33P LH	39P LH
C6	27P LH	33P LH
C22	6P(D) UJ	3P(C) UJ

FRONT END PCB C1005B5040

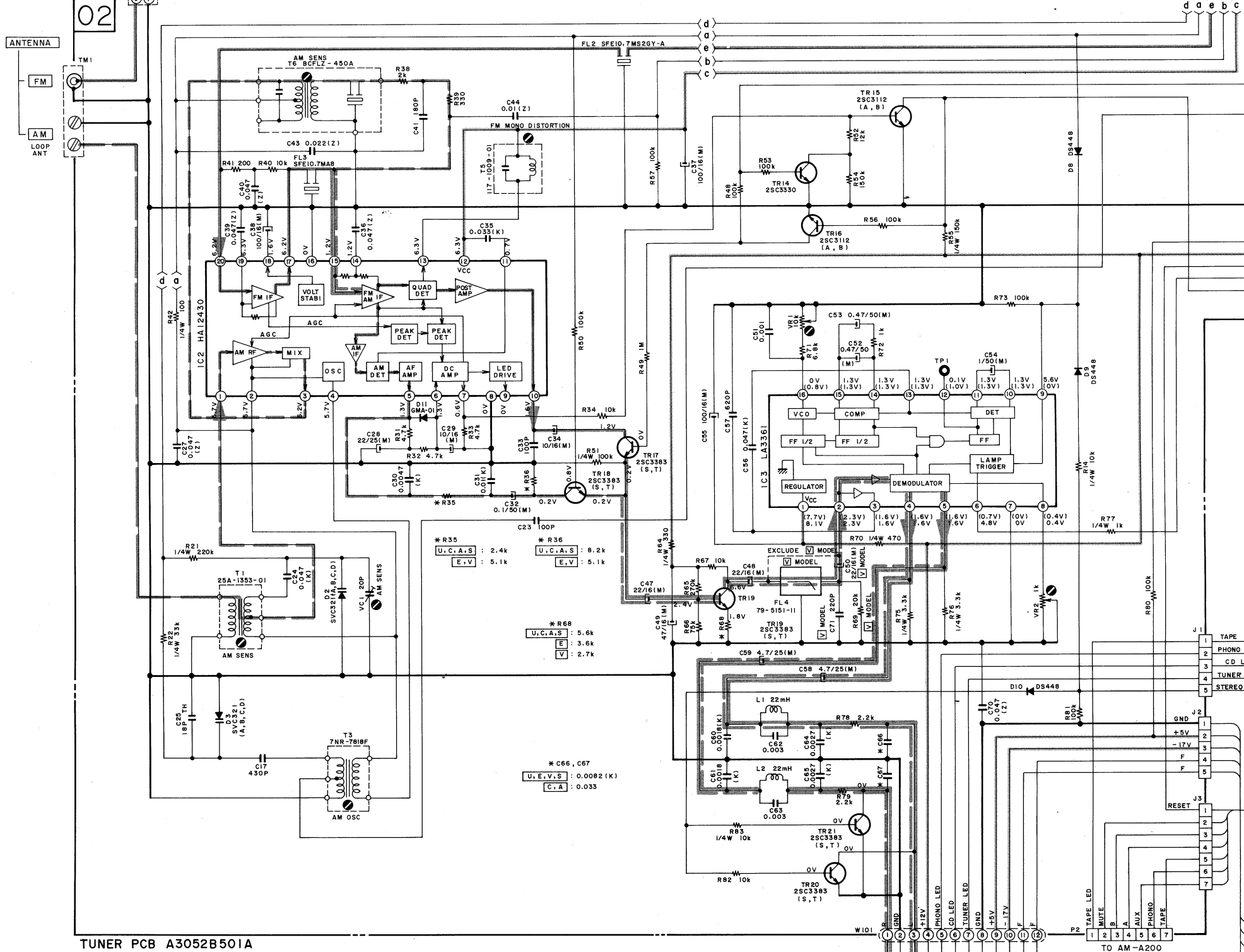

TUNER PCB A3052B501A

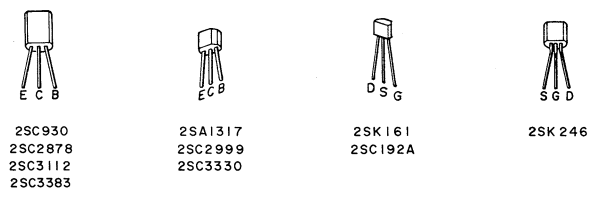

- 2SC930
- 2SC2878
- 2SC2999
- 2SC3112
- 2SC3363
- 2SA1317
- 2SC2999
- 2SC3330
- 2SK161
- 2SC192A
- 2SK246

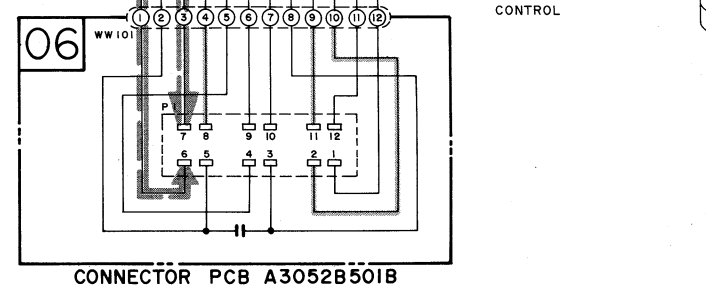

CONNECTOR PCB A3052B501B

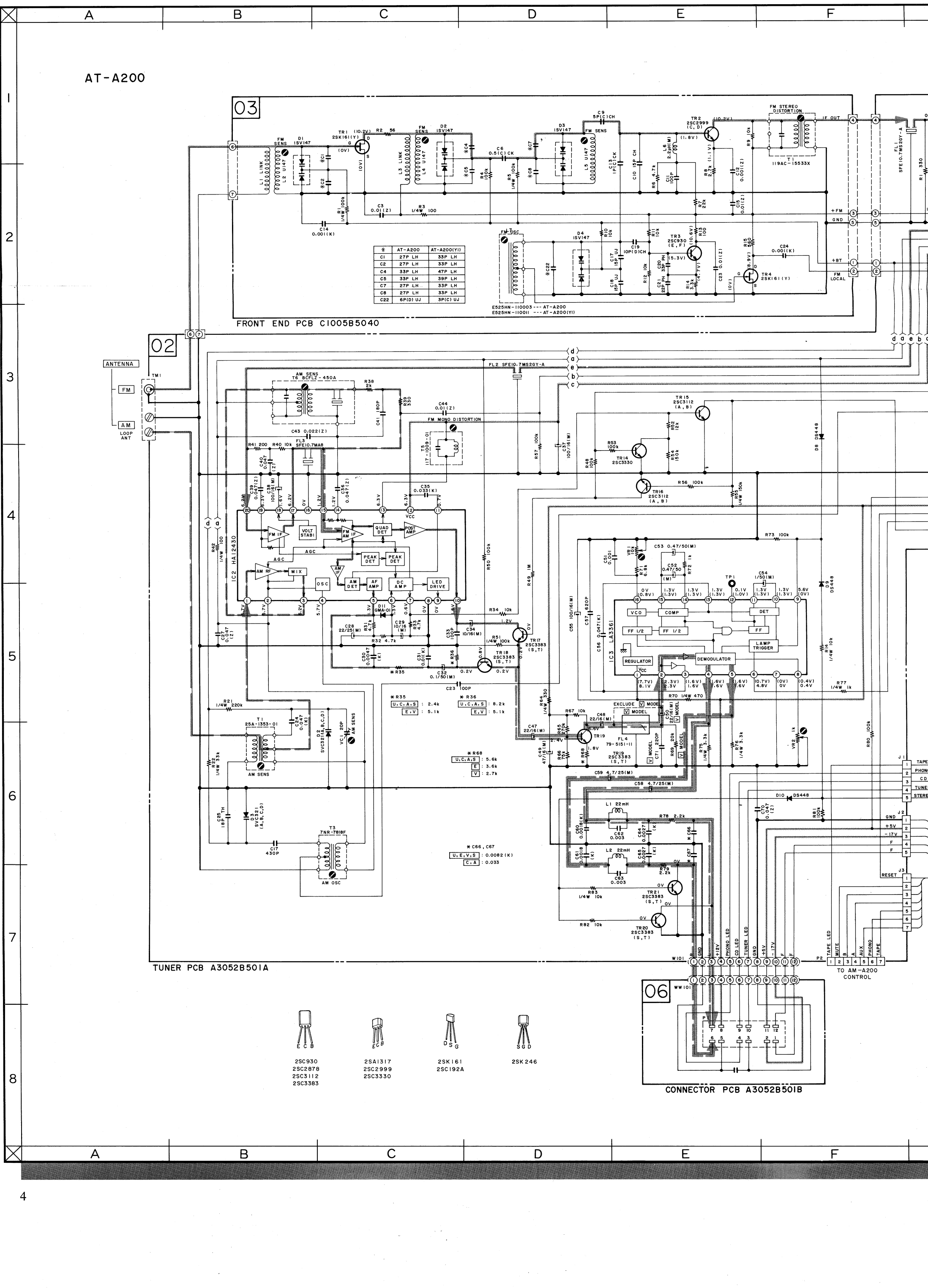

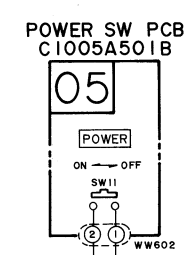
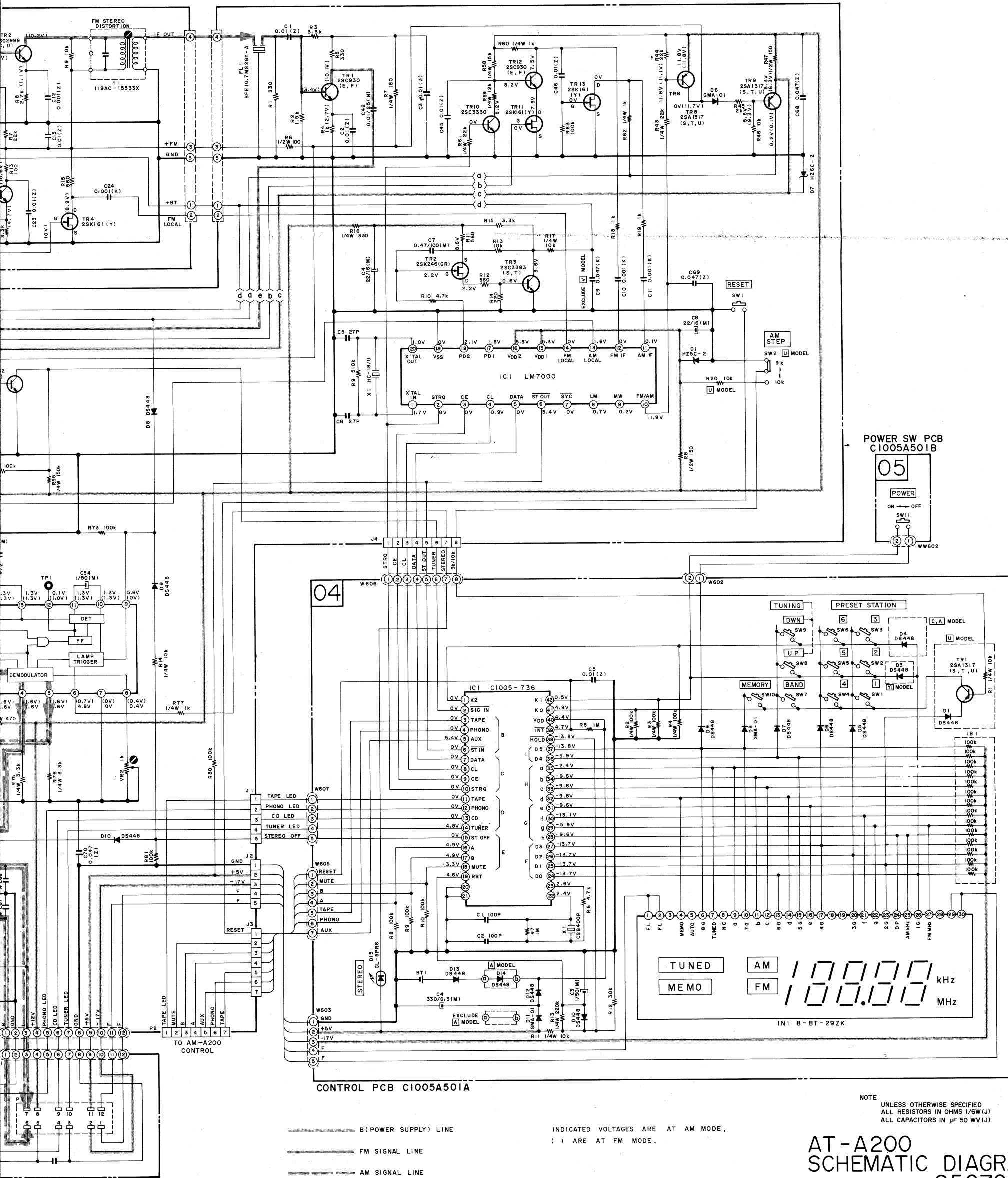

04

CONTROL PCB C1005A501A

NOTE
UNLESS OTHERWISE SPECIFIED
ALL RESISTORS IN OHMS 1/6W(J)
ALL CAPACITORS IN uF 50V(J)

AT-A200
SCHEMATIC DIAGRAM
No. 850703A

RECTOR PCB A3052B501B

LOCATION OF COMPONENTS

TRANSISTOR'S

- TR1.....C1
- TR2.....C2
- TR3.....C2
- TR8.....B2
- TR9.....B2/B3
- TR10.....C2
- TR11.....C3
- TR12.....C3
- TR13.....C2
- TR14.....C3
- TR15.....C3
- TR16.....C3
- TR17.....C3
- TR18.....C3
- TR19.....C4
- TR20.....D2
- TR21.....D2

IC'S

- IC1.....C2/D2
- IC2.....B3
- IC3.....D3

CONNECTOR'S

- J1.....E4
- J2.....E3
- J3.....E2/E3
- W101.....D2
- P2.....A1

- TR1, 12.....2SC930 (E, F)
- TR2.....2SK246 (G, R)
- TR3, 17, 18, 19, 20, 21...2SC3383 (S, T)
- TR10, 14.....2SC3330
- TR8, 9.....2SA1317 (S, T, U)
- TR11, 13.....2SK161 (Y)
- TR15, 16.....2SC3112 (A, B)

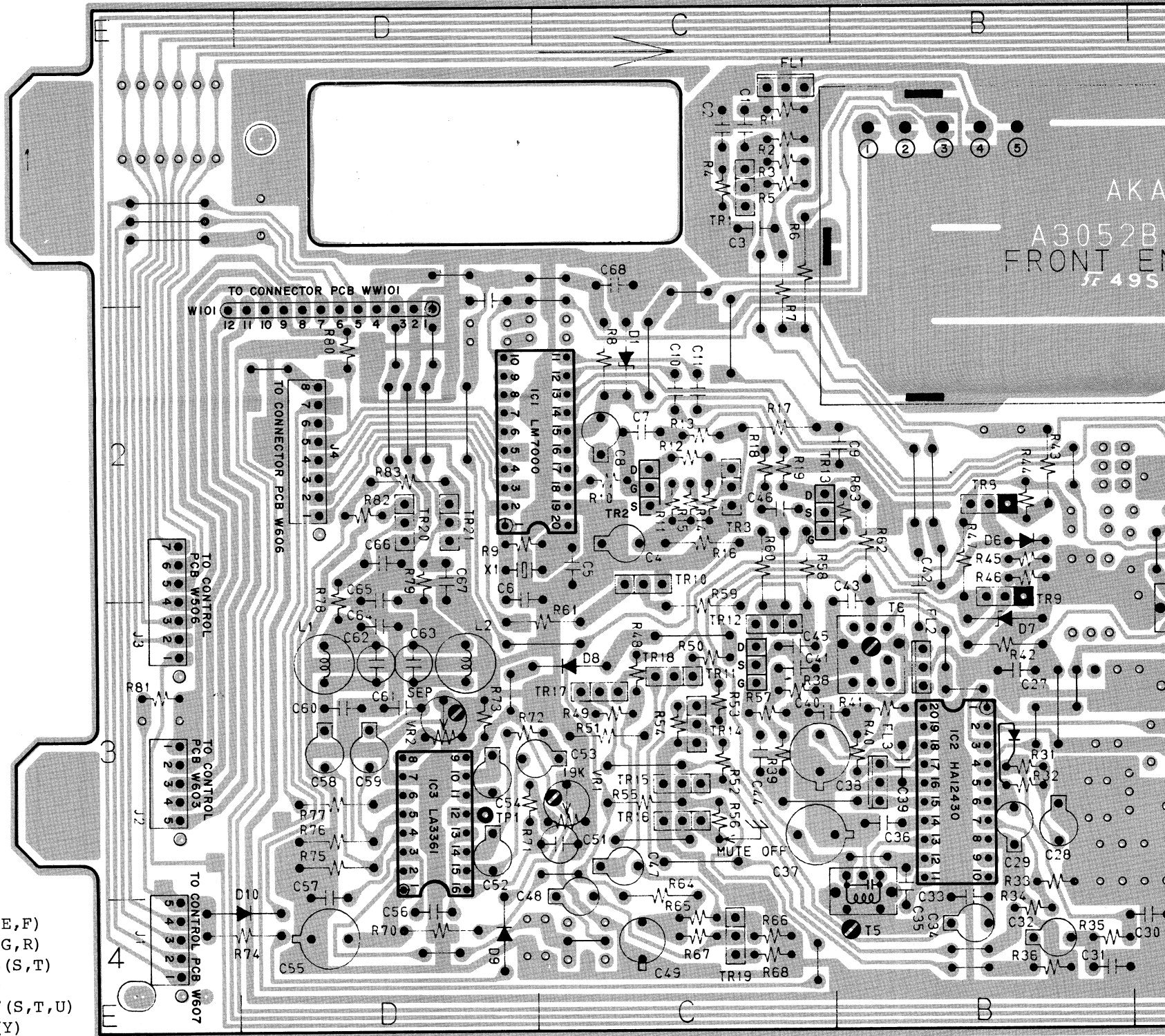

TUNER PCB A3052B501A

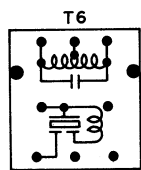

●●● = PNP TRANSISTOR

○●○ = NPN TRANSISTOR

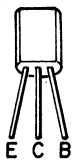

2SC930
2SC2878
2SC3112
2SC3383



2SK246



2SA1317
2SC2999
2SC3330



2SK161
2SK192A

* :SEE CHART OF DISTINATION

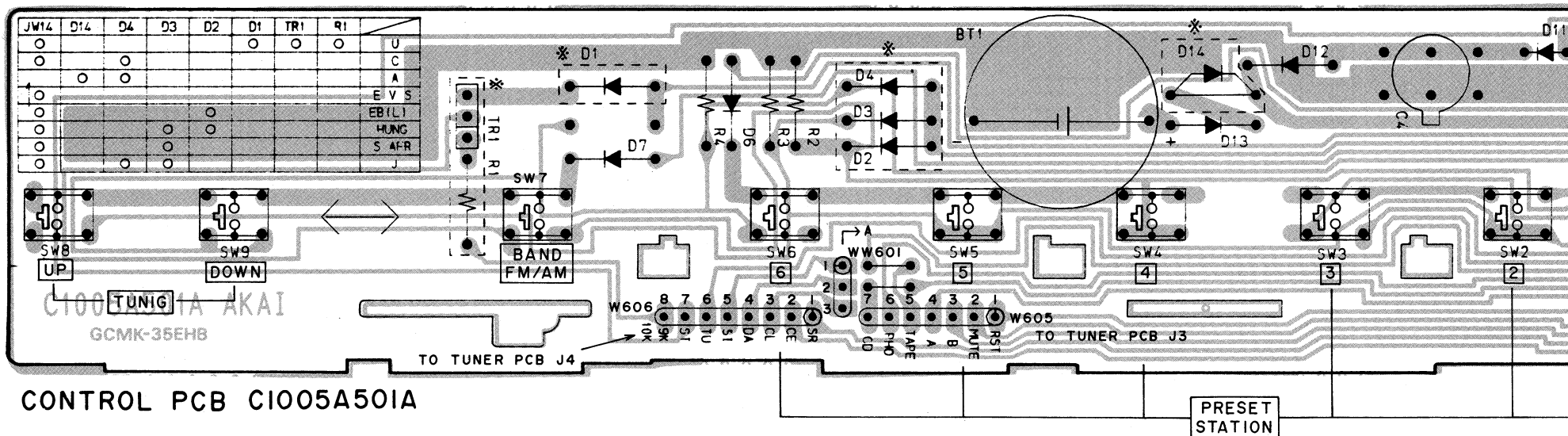

CONTROL PCB C1005A501A

PRESET STATION

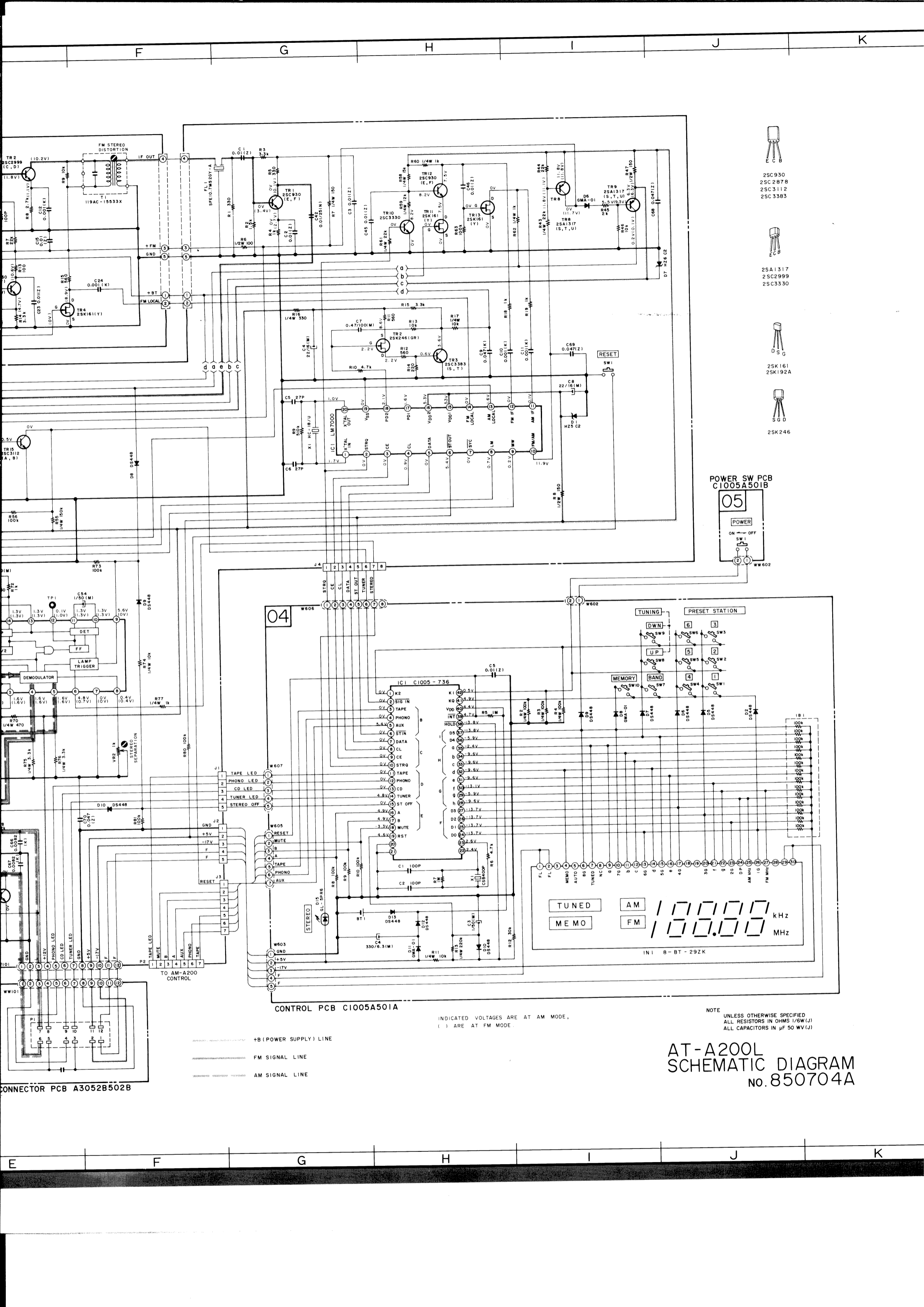

2SC930
2SC2878
2SC3112
2SC3383

2SA1317
2SC2999
2SC3330

2SK161
2SK192A

SGD
2SK246

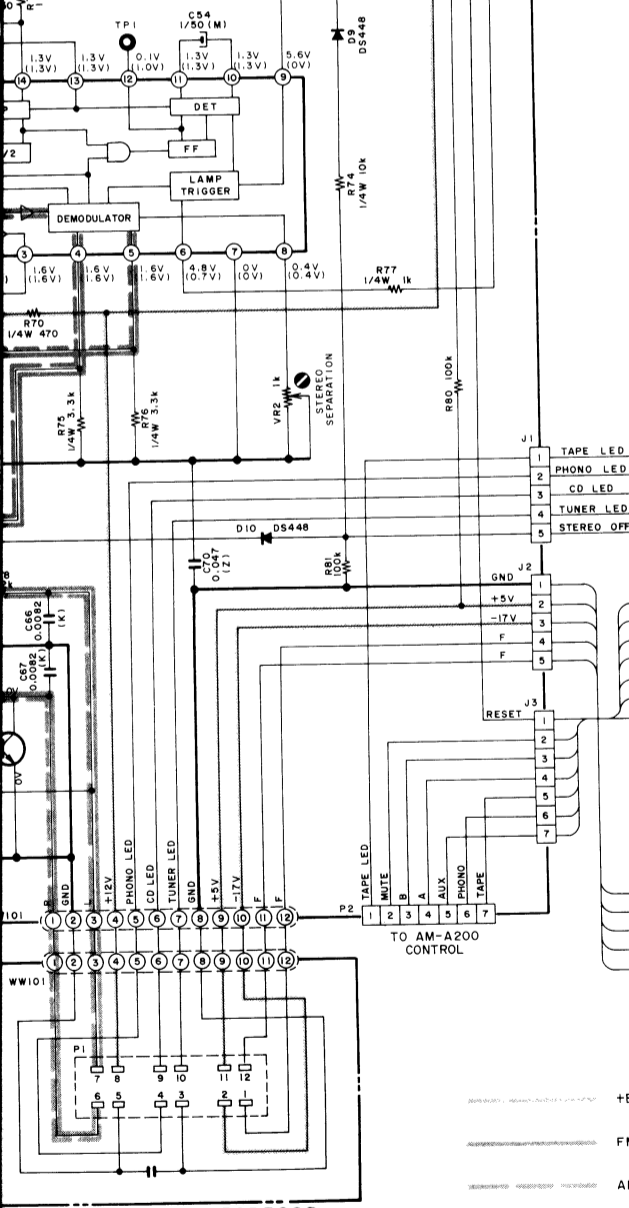
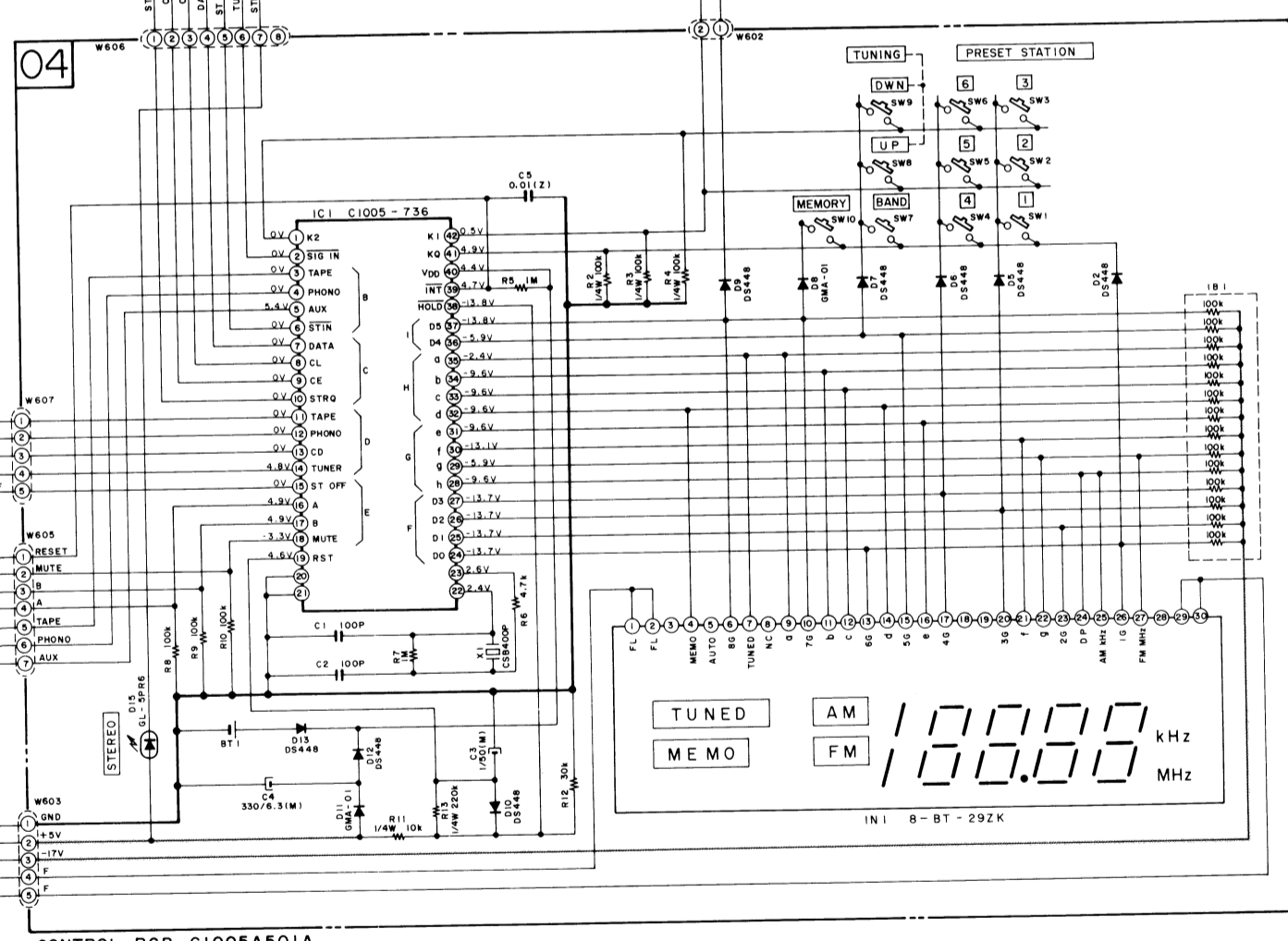
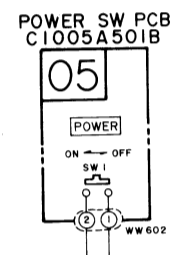

INDICATED VOLTAGES ARE AT AM MODE.
() ARE AT FM MODE.

NOTE
UNLESS OTHERWISE SPECIFIED
ALL RESISTORS IN OHMS 1/6W (J)
ALL CAPACITORS IN μ F 50 WV (J)

AT-A200L
SCHEMATIC DIAGRAM
No. 850704A

----- +B (POWER SUPPLY) LINE
----- FM SIGNAL LINE
----- AM SIGNAL LINE

LOCATION OF COMPORNENTS

- TRANSISTOR'S
 TR1.....C1
 TR2.....C2
 TR3.....C2
 TR4.....A3
 TR5.....A3
 TR6.....A2
 TR7.....B3
 TR8.....B2
 TR9.....B2/B3
 TR10.....C2
 TR11.....C3
 TR12.....C3
 TR13.....C2
 TR14.....C3
 TR15.....C3
 TR16.....C3
 TR17.....C3
 TR18.....C3
 TR19.....C4
 TR20.....D2
 TR21.....D2
 TR22.....B2
 TR23.....B2

- IC'S
 IC1.....C2/D2
 IC2.....B3
 IC3.....D3

- CONNECTOR'S
 J1.....E4
 J2.....E3
 J3.....E2/E3
 W101.....D2
 P2.....A1

- TR1, 12.....2SC930 (E,F)
 TR2.....2SK246 (G,R)
 TR3, 17, 18, 19, 20, 21...2SC3383 (S,T)
 TR4, 6.....2SC2878 (A,B)
 TR5.....2SK192 (G,R)
 TR7, 10, 14, 22, 23.....2SC3330
 TR8, 9.....2SA1317 (S,T,U)
 TR11, 13.....2SK161 (Y)
 TR15, 16.....2SC3112 (A,B)

B
 = NPN TRANSISTOR
 B
 = PNP TRANSISTOR

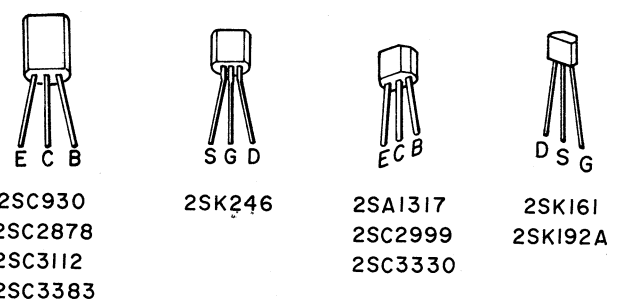

* :SEE CHART OF DISTINATION

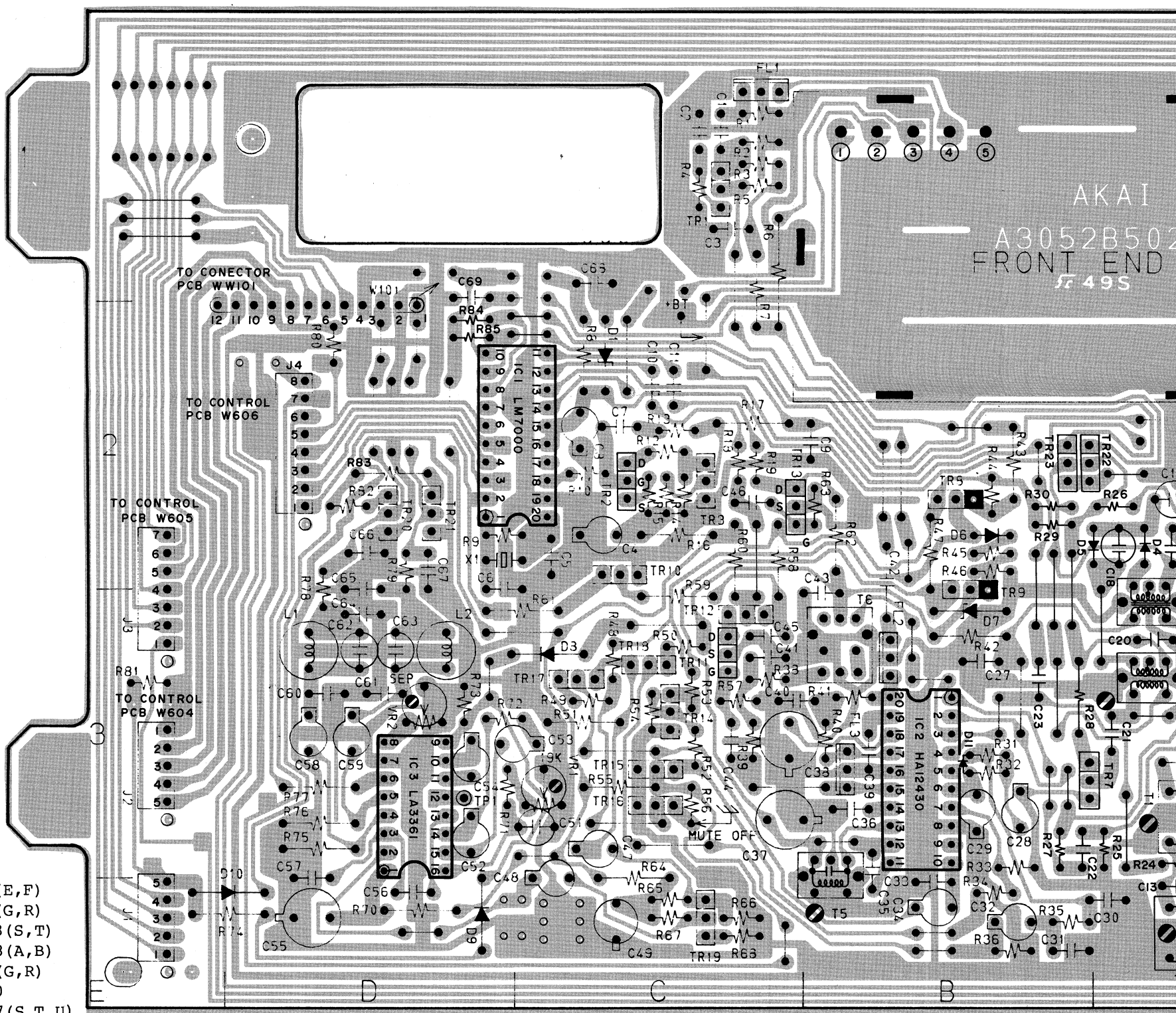
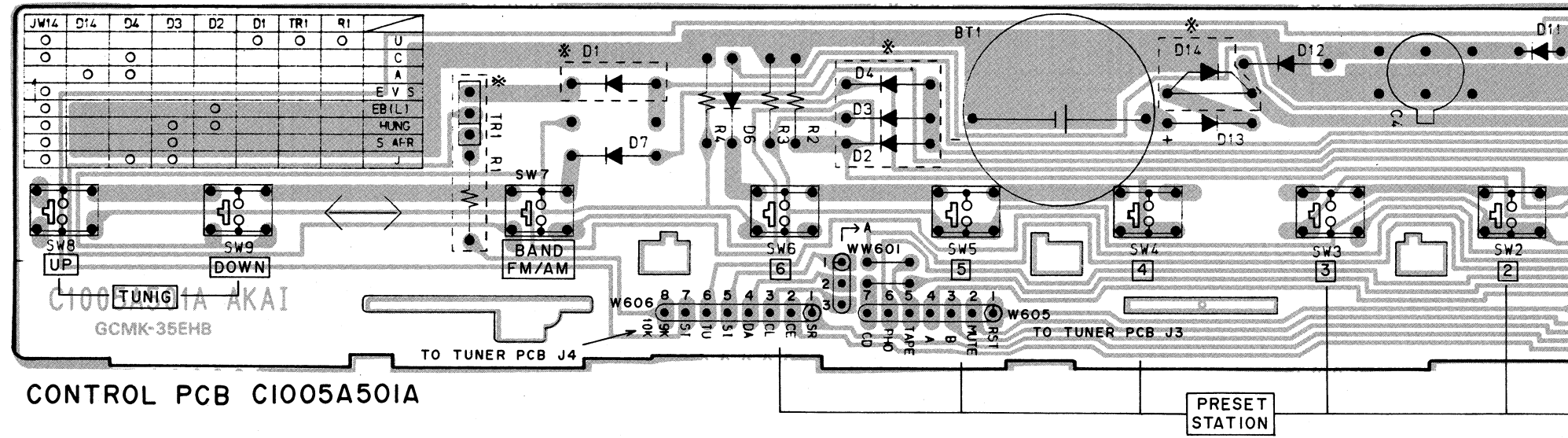

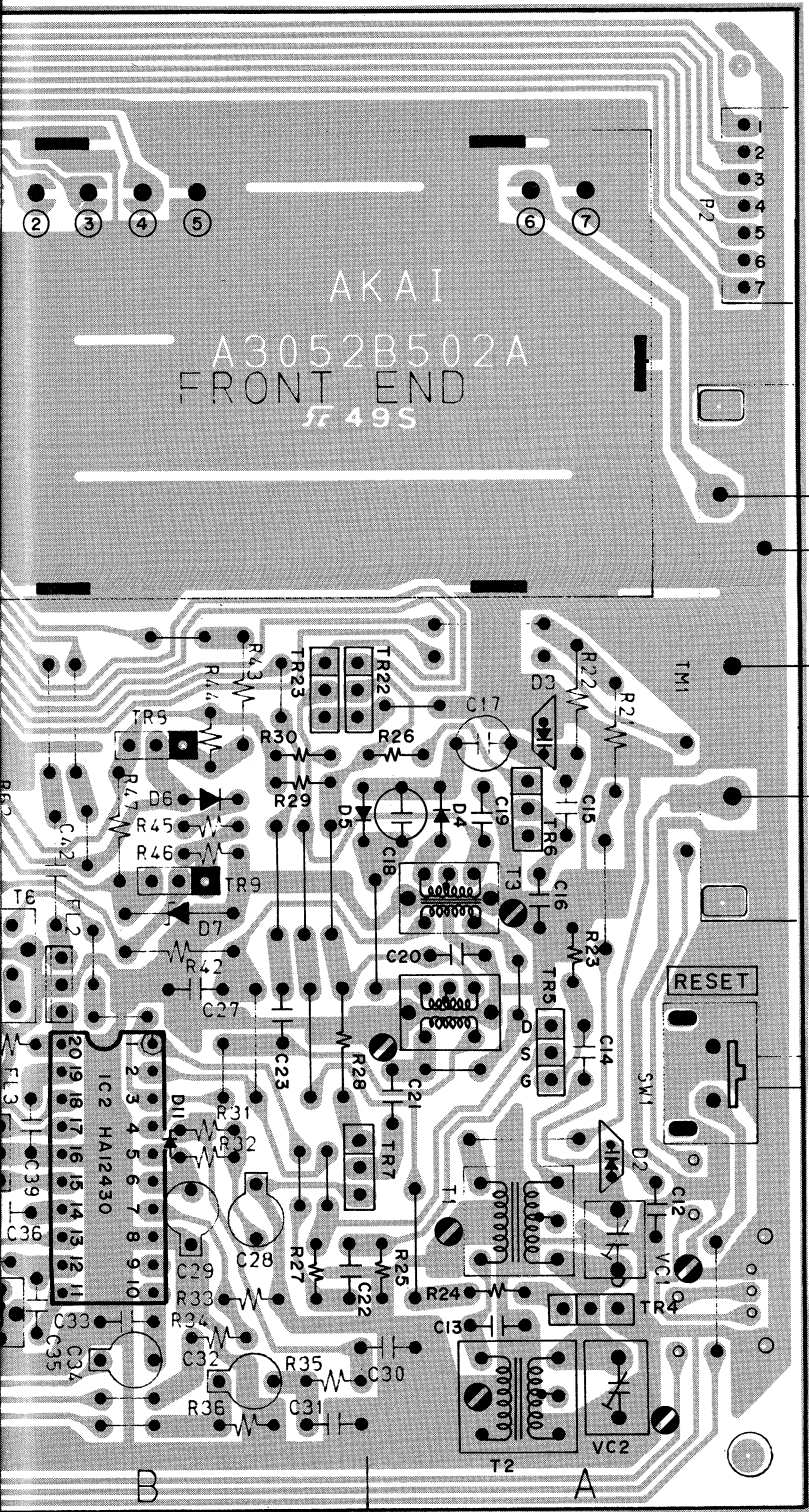

TUNER PCB A3052B502A

CONTROL
TO AM-A200

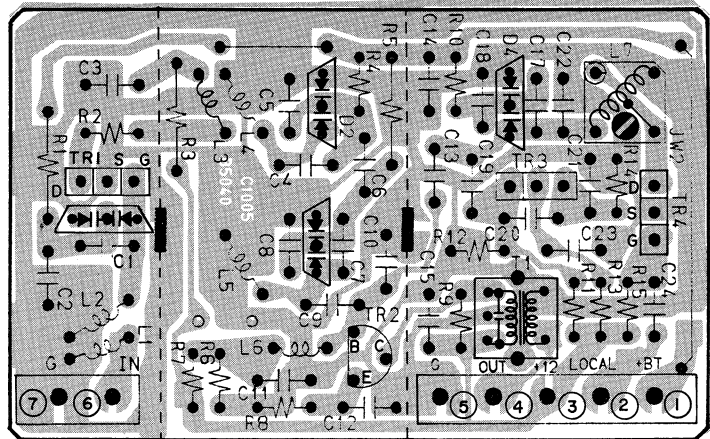
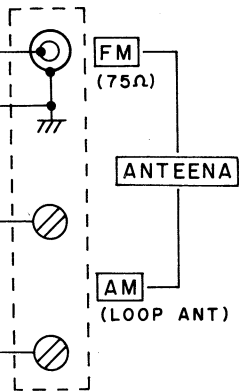

FRONT END PCB C1005B5040

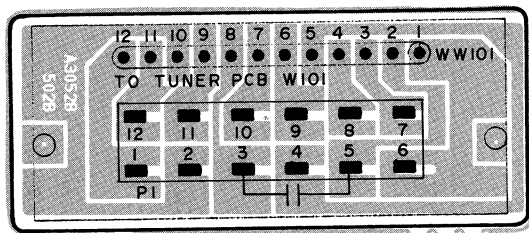

CONNECTOR PCB A3052B502B

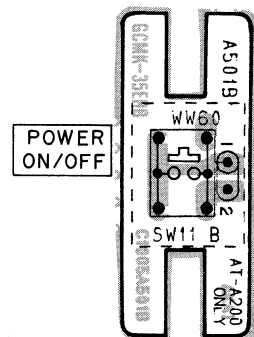

POWER SW PCB
C1005A501B

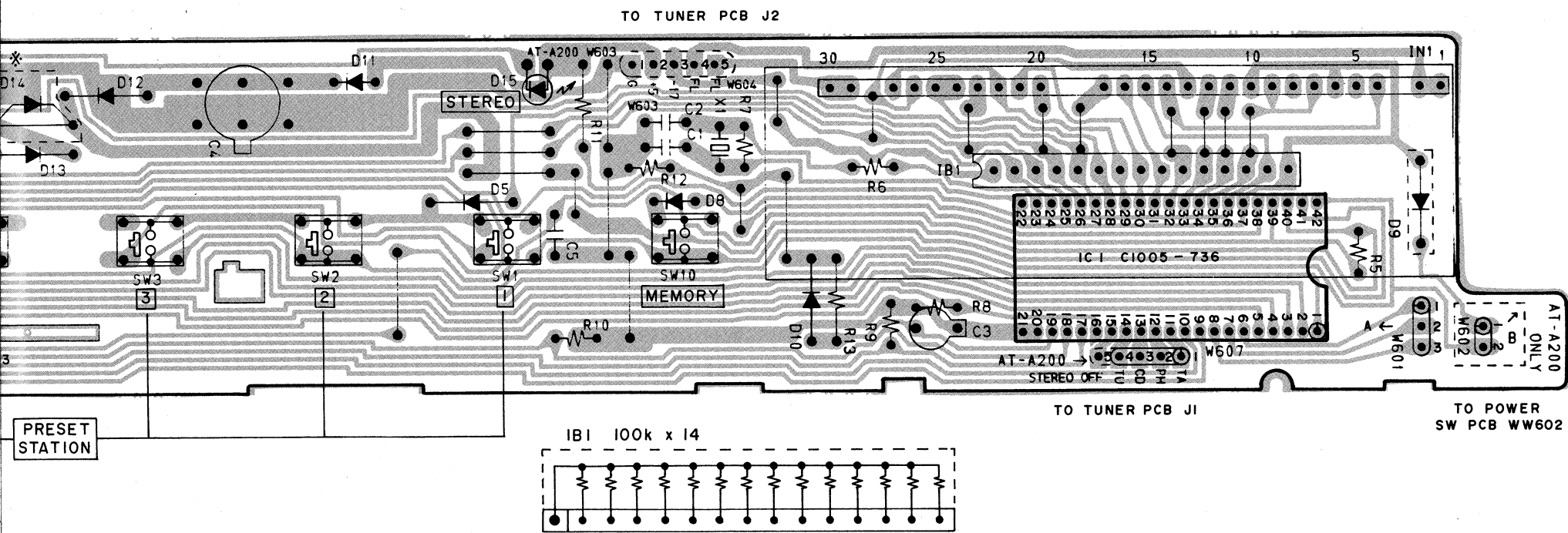
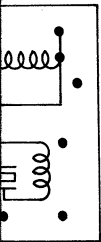

TO TUNER PCB J2

TO TUNER PCB J1

TO POWER
SW PCB WW602

IB1 100k x 14

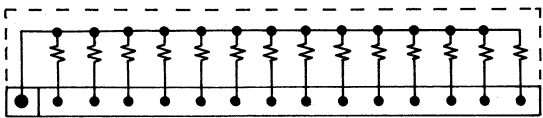

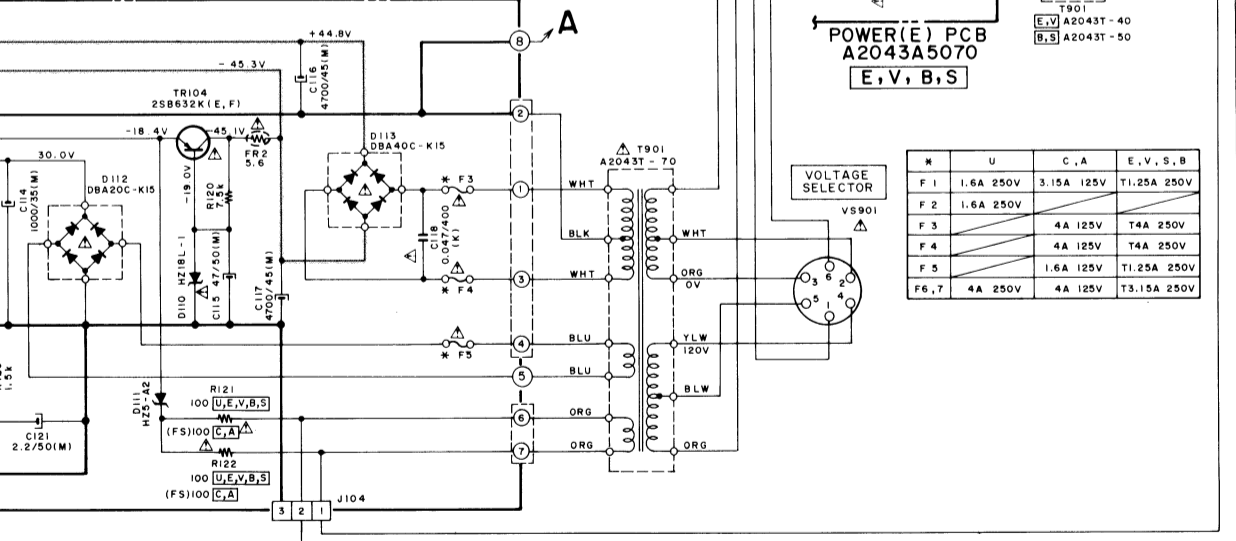
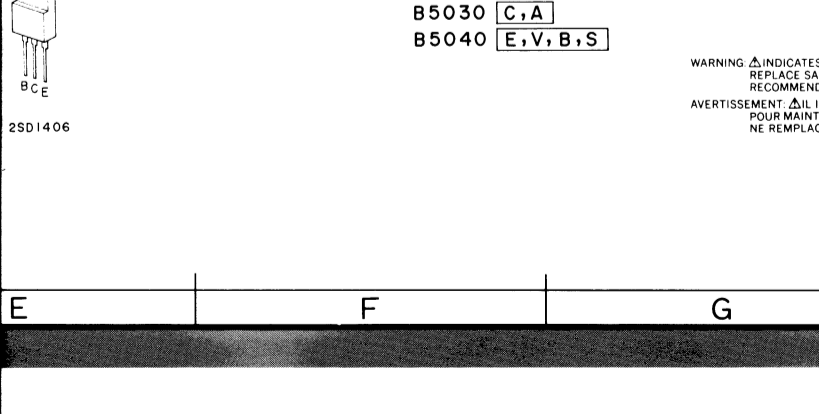
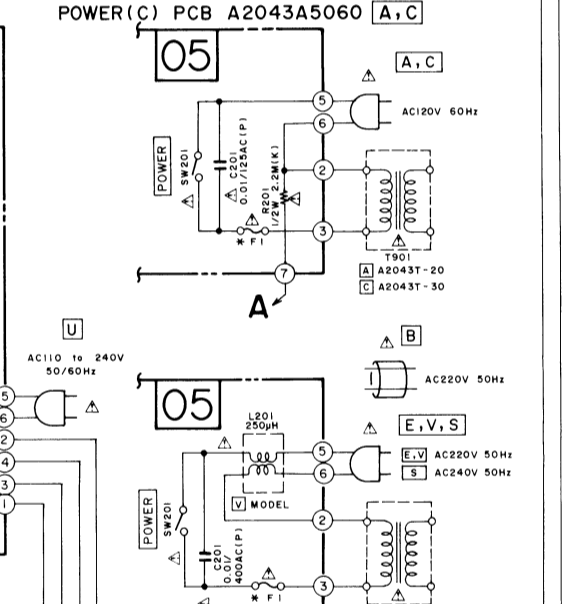
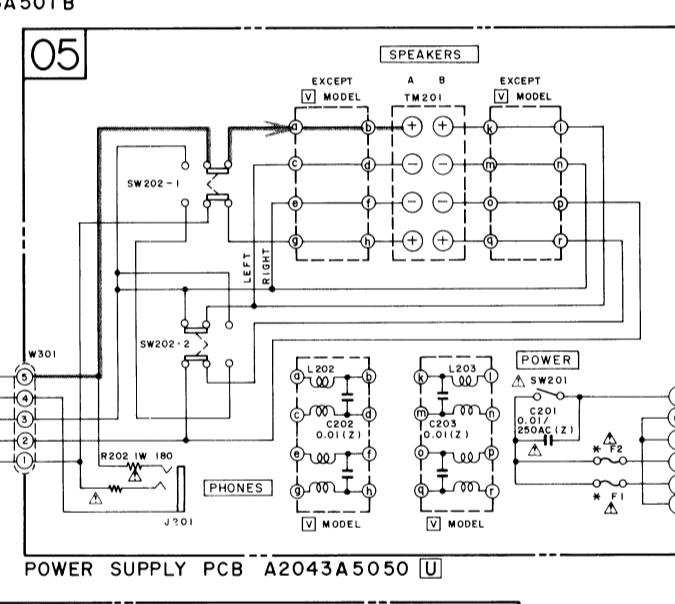
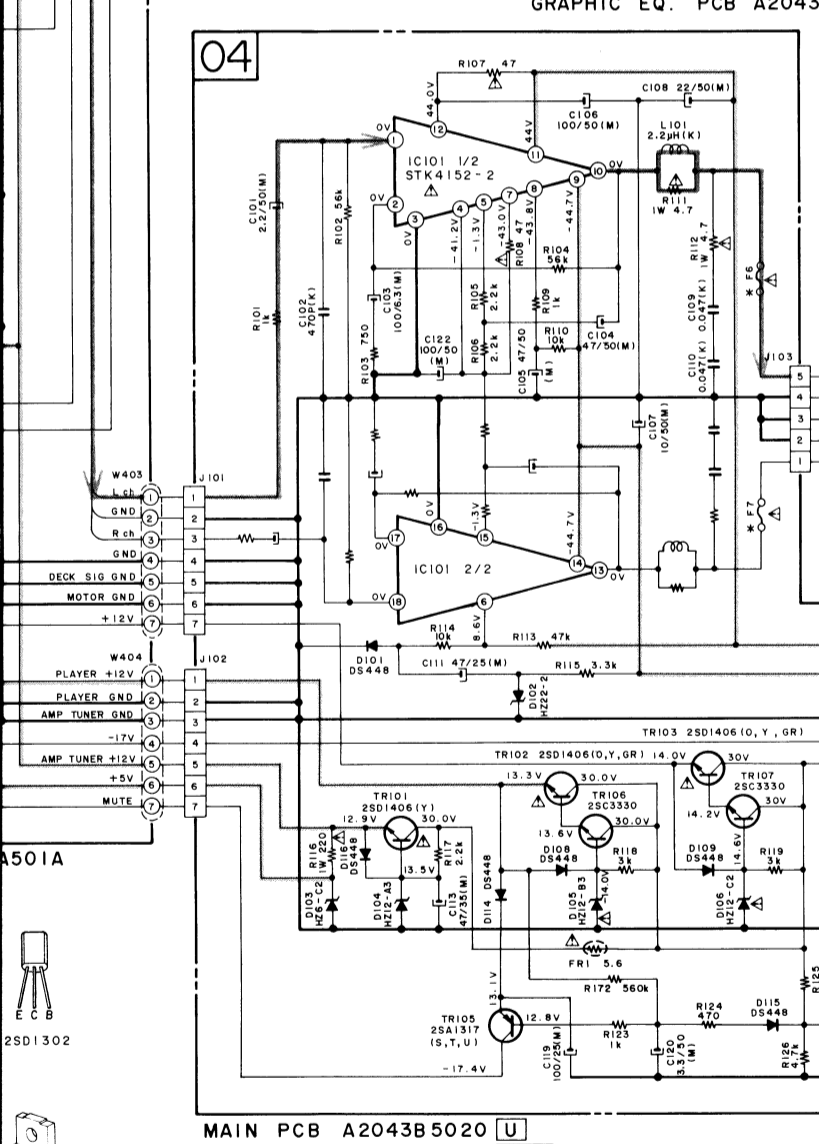
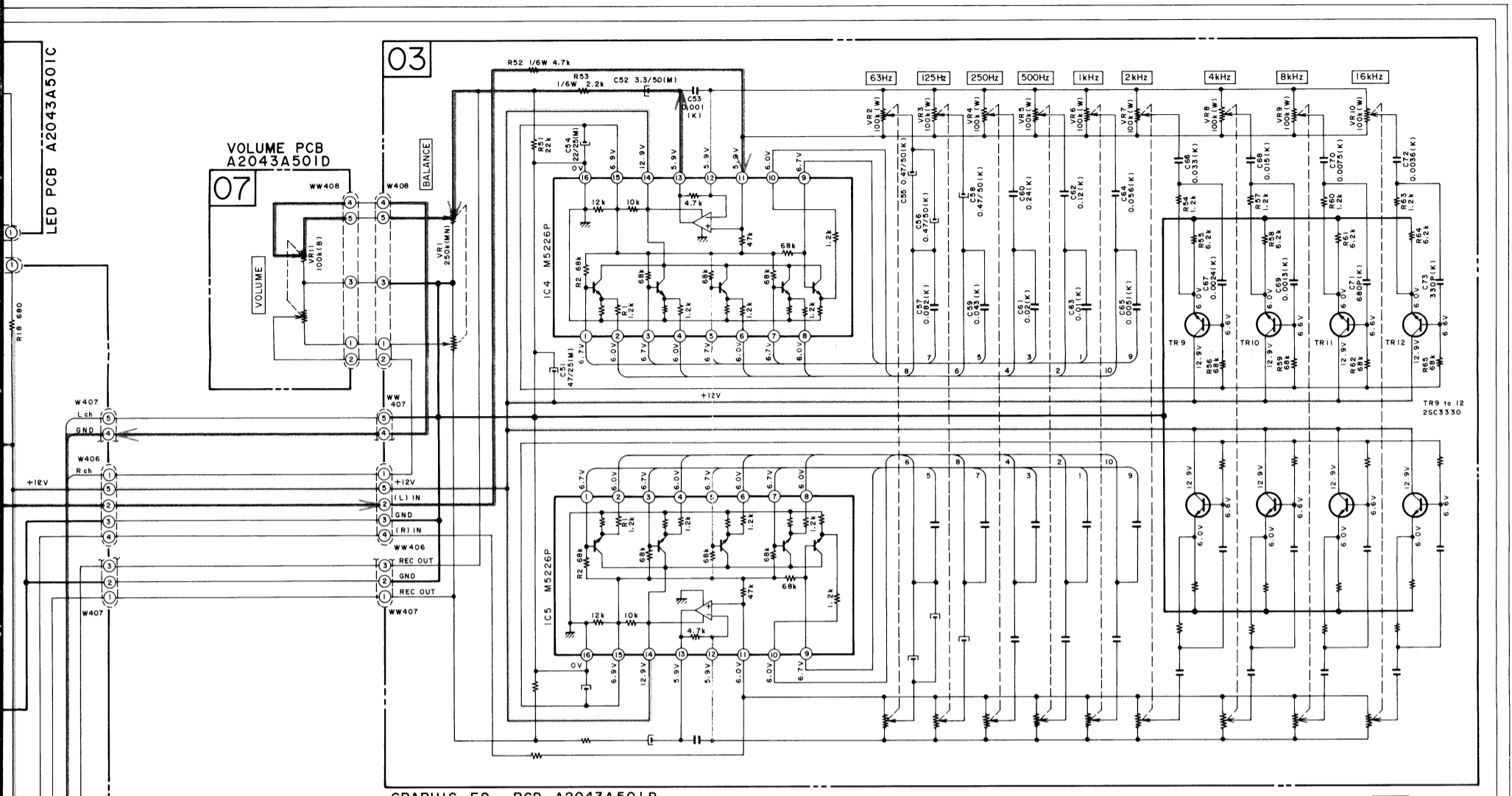

WARNING Δ INDICATES SAFETY CRITICAL COMPONENTS FOR CONTINUED SAFETY. REPLACE SAFETY CRITICAL COMPONENTS ONLY WITH MANUFACTURER'S RECOMMENDED PARTS.
 AVERTISSEMENT Δ IL INDIQUE LES COMPOSANTS CRITIQUES DE SÉCURITÉ. POUR MAINTENIR LE DEGRÉ DE SÉCURITÉ DE L'APPAREIL, NE REMPLACER QUE DES PIÈCES RECOMMANDÉES PAR LE FABRICANT.

NOTE
 UNLESS OTHERWISE SPECIFIED
 ALL RESISTORS IN OHMS 1/4W(J)
 ALL CAPACITORS IN μ F 50WV(J)
 POWER TRANSFORMER IS DIFFERENT
 ACCORDING TO AREA
 (FS) = FAIL SAFE RESISTORS

AM - A200 SCHEMATIC DIAGRAM No. 850610A

	U	C, A	E, V, S, B
F 1	1.6A 250V	3.15A 125V	T1.25A 250V
F 2	1.6A 250V		
F 3		4A 125V	T4A 250V
F 4		4A 125V	T4A 250V
F 5		1.6A 125V	T1.25A 250V
F 6, 7	4A 250V	4A 125V	T3.15A 250V

CONNECTOR(A) PCB A2043A501E

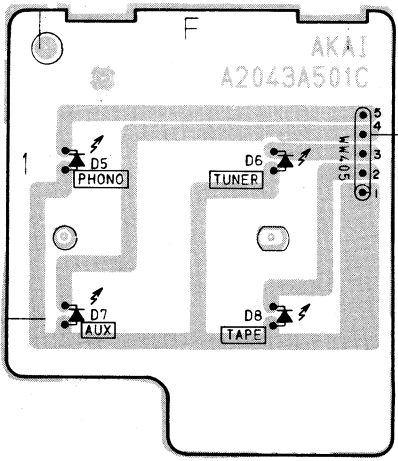
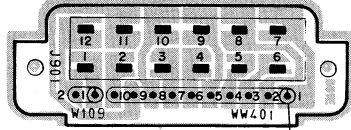

LED PCB A2043A501C

- = NPN TRANSISTOR
- = PNP TRANSISTOR

LOCATION OF COMPONENTS

- TRs
 TR1...A2
 TR2...D1
 TR3...D1
 TR4...E1
 TR5...E1
 TR6...E1
 TR7...E1
 TR8...E2

- ICs
 IC1...A1
 IC2...B1
 IC3...D1

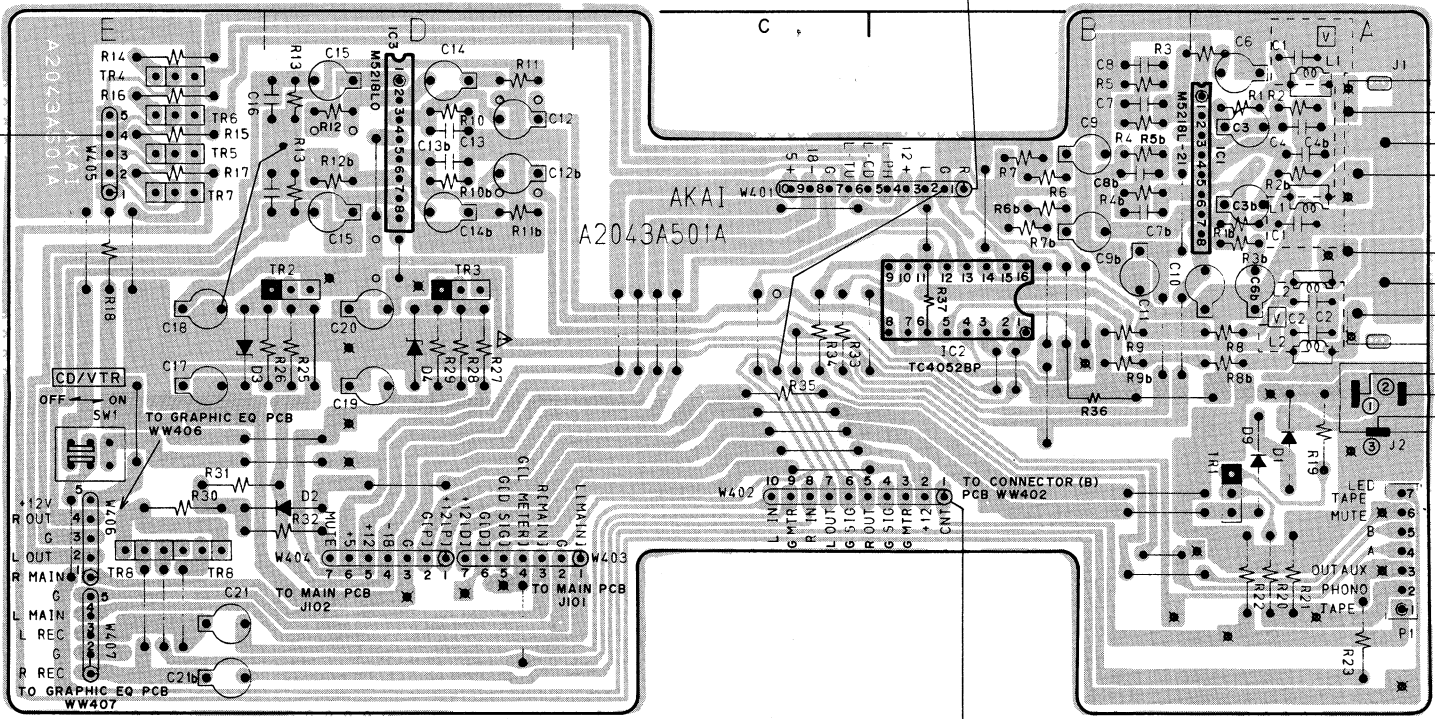

PRE AMP PCB A2043A501A



2SD1302



2SA1317
2SC3330

CONNECTOR(B) PCB A2043A501F

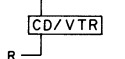
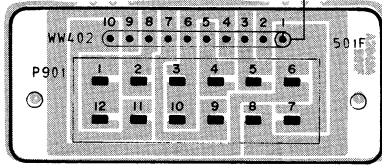

POWER SUPPLY
 DC 12V
 TO AP-A100
 AP-A200

CONTROL
 TO AT-200

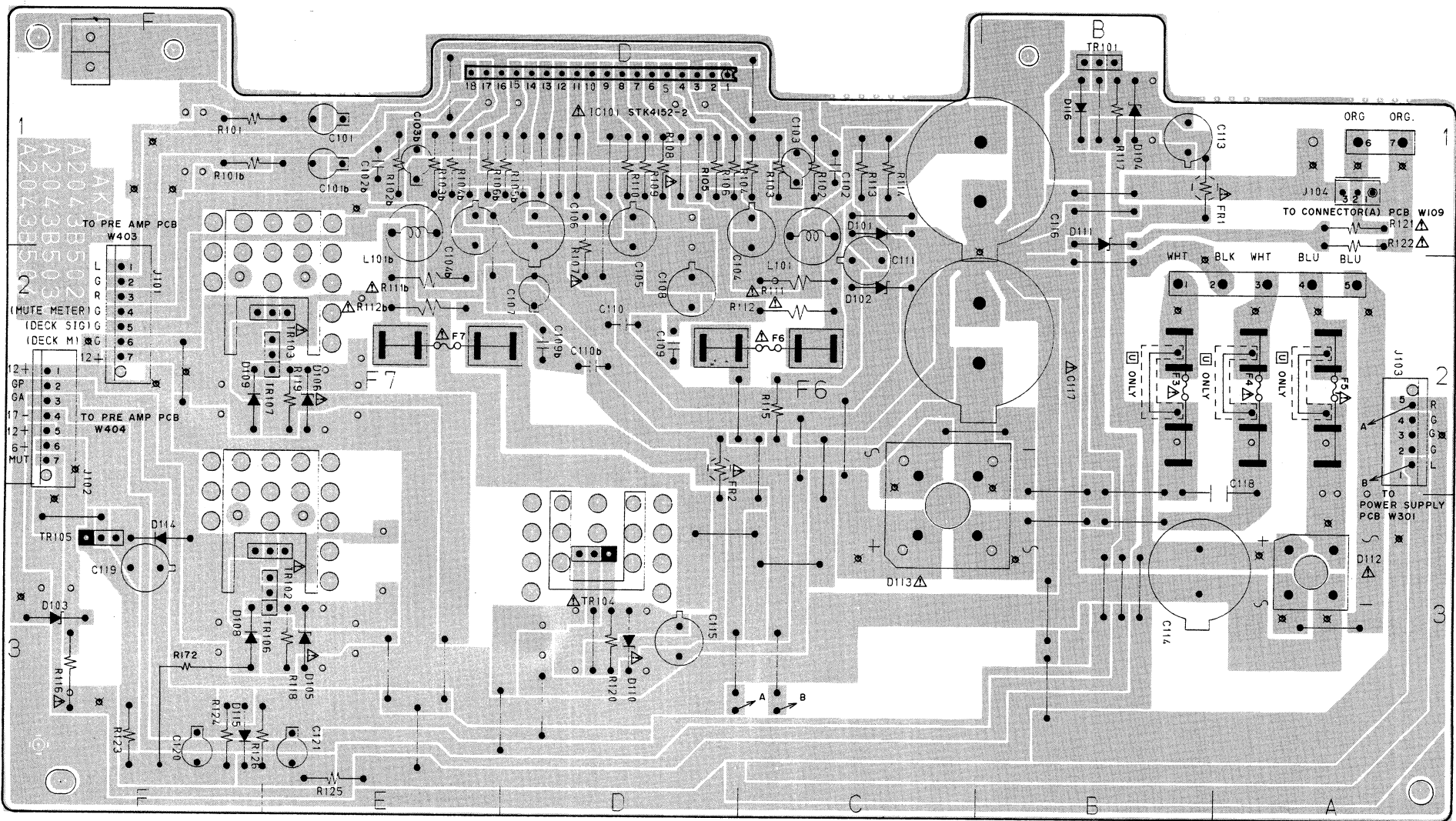

MAIN PCB A2043B5020

5030 C.A.
 5040 E.V.B.S.

- = NPN TRANSISTOR
- = PNP TRANSISTOR



2SC3330

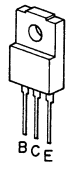

2SD1406

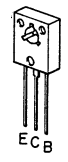

2SB632K

LOCATION OF COMPONENTS

- TRs
 TR101..B1
 TR102..E3
 TR103..E2
 TR104..D3
 TR105..F3
 TR106..E3
 TR107..E2

- ICs
 IC101..D1

WARNING: INDICATES SAFETY CRITICAL COMPONENTS FOR CONTINUED SAFETY. REPLACE SAFETY CRITICAL COMPONENTS ONLY WITH MANUFACTURER'S RECOMMENDED PARTS

AVERTISSEMENT: INDIQUE LES COMPOSANTS CRITIQUES DE SÉCURITÉ. POUR MAINTENIR LE DEGRÉ DE SÉCURITÉ DE L'APPAREIL, NE REMPLACER QUE DES PIÈCES RECOMMANDÉES PAR LE FABRICANT

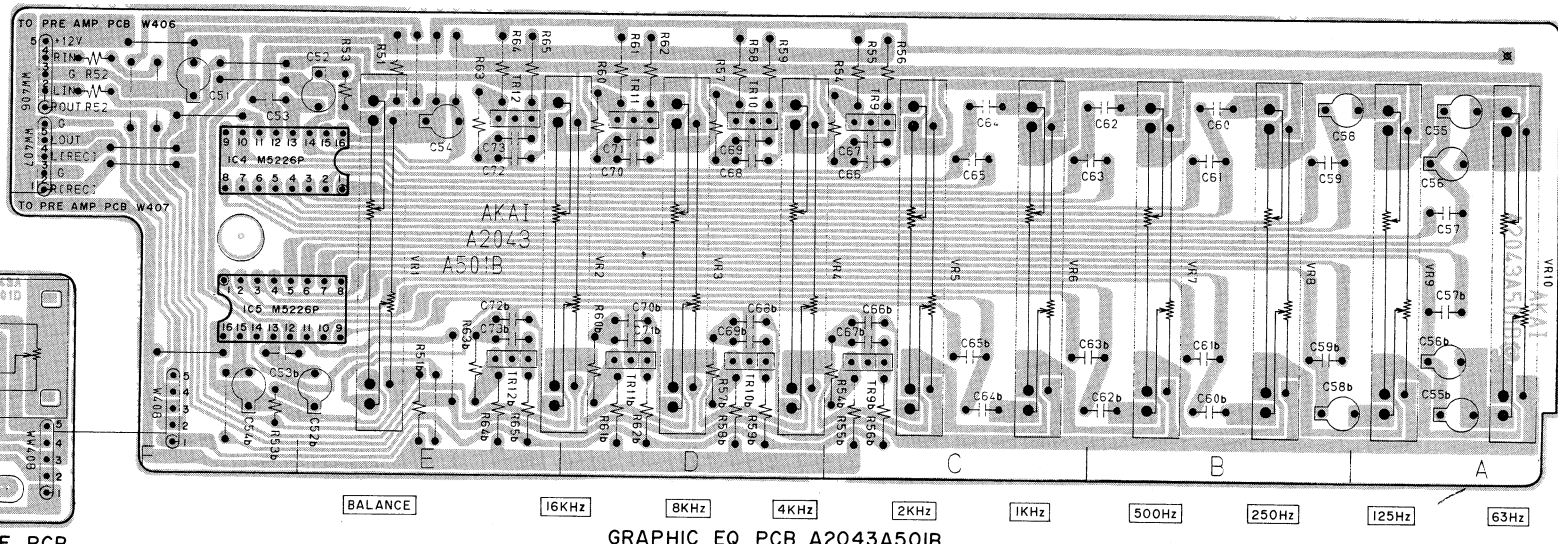
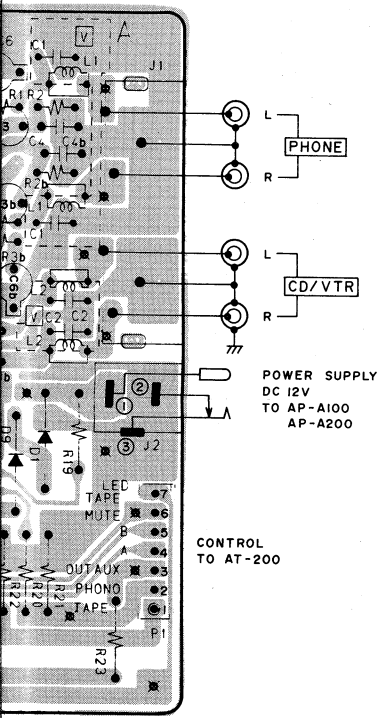

VOLUME PCB A2043A501D

LOCATION OF COMPONENTS

- TRs
 TR9...C3
 TR10...D3
 TR11...D3
 TR12...E3
- ICs
 IC4...E,F3
 IC5...E,F4

• = NPN TRANSISTOR

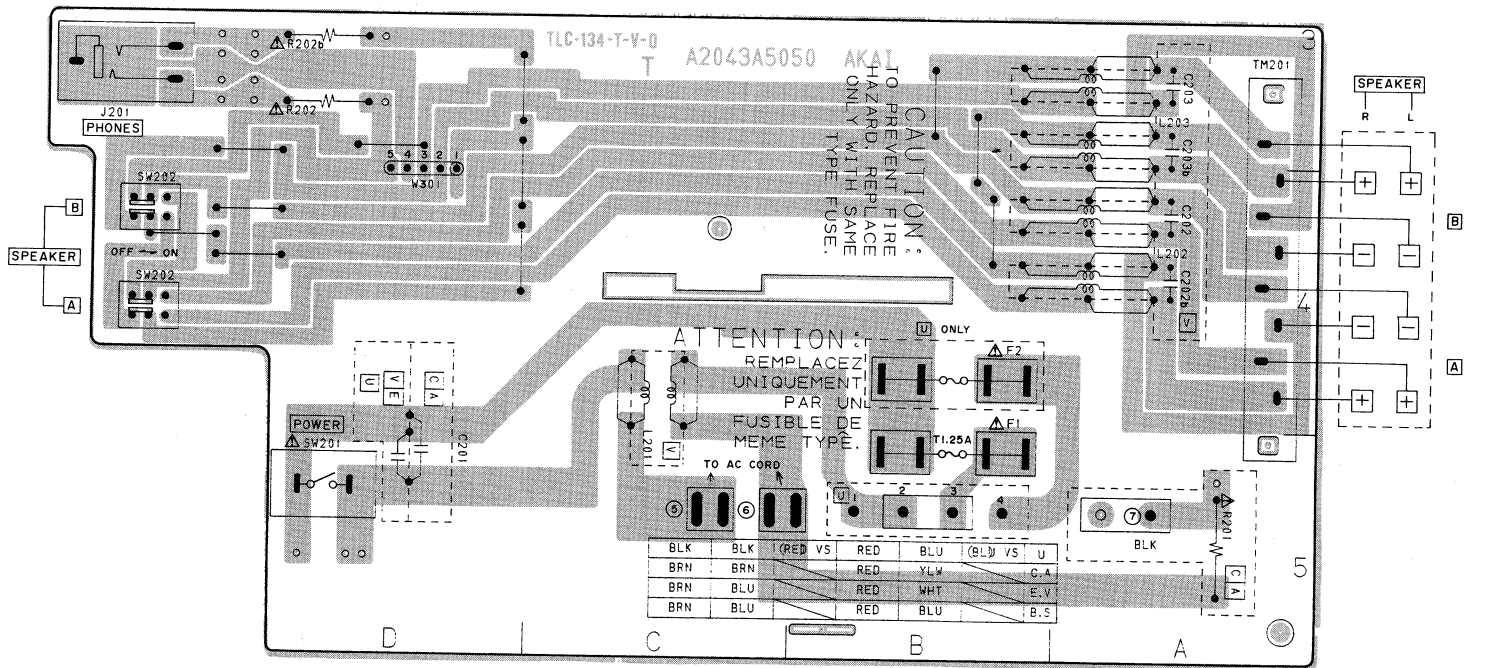
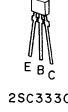

POWER SUPPLY PCB A2043A5050
 5060 A.C.
 5070 E.V.B.S.

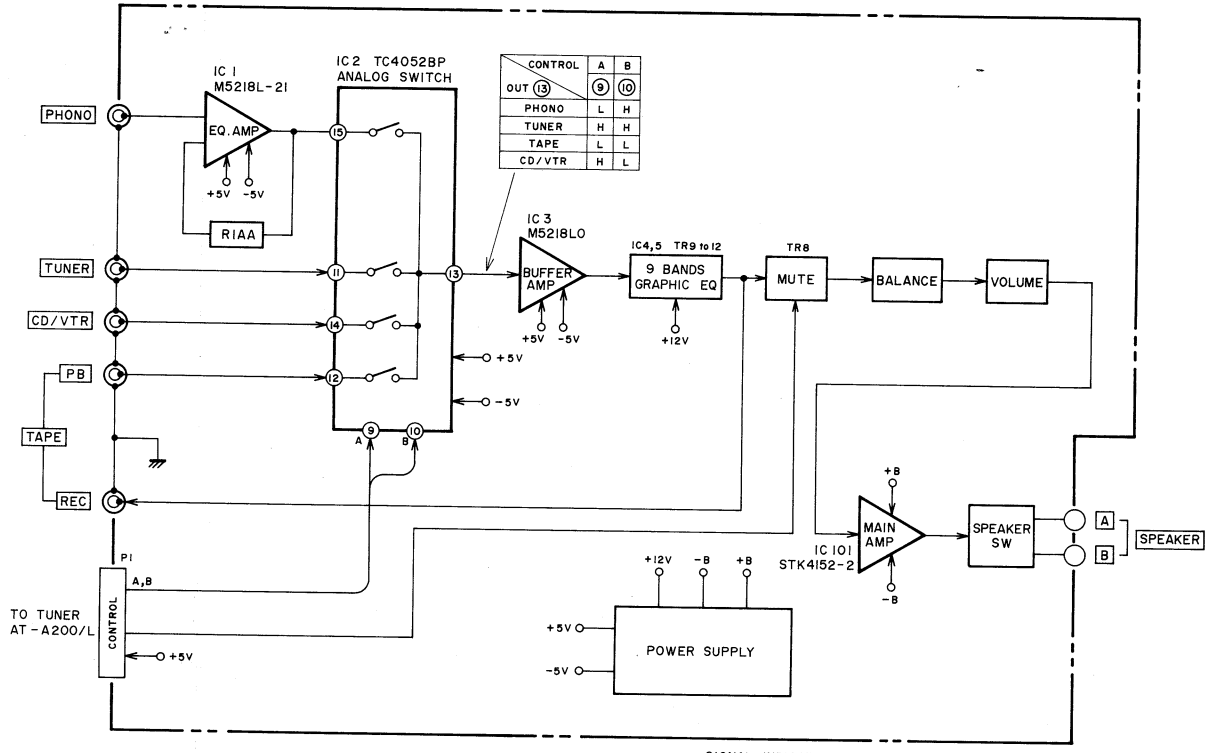
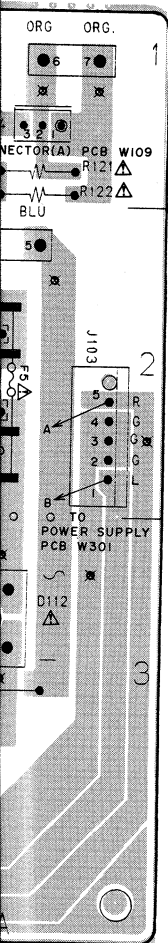

SIGNAL INDICATED AT L CHANNEL ONLY

AM-A200
 BLOCK DIAGRAM
 No. 850611A

FOR CONTINUED SAFETY, READ INSTRUCTIONS CAREFULLY WITH MANUFACTURER'S INSTRUCTIONS.
 POUR LA SECURITE, LIRE ATTENTIVEMENT LES INSTRUCTIONS DU FABRICANT.

HX-A200

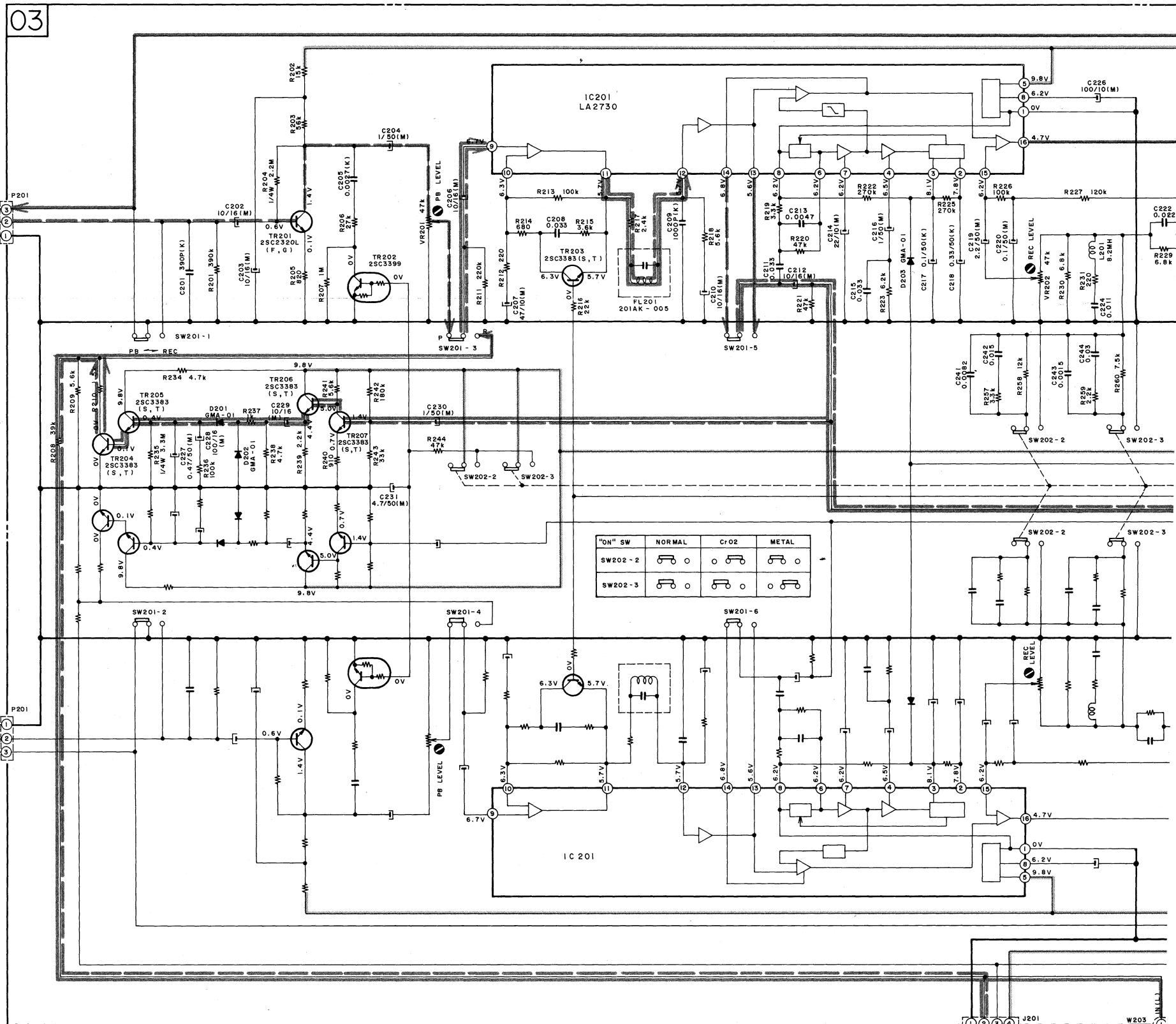

PRE AMP PCB T2085B501A

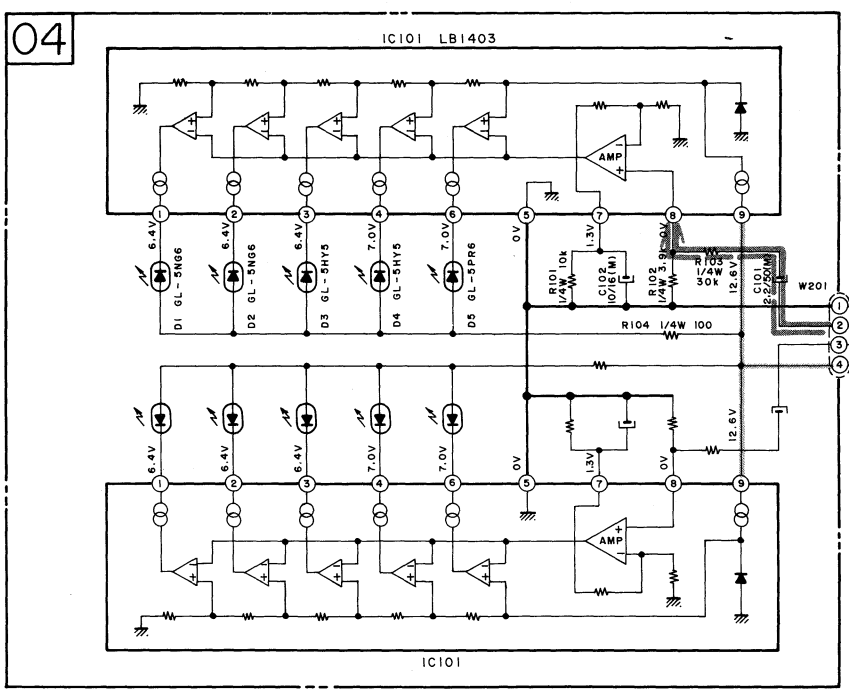

LEVEL METER PCB T2085B5020

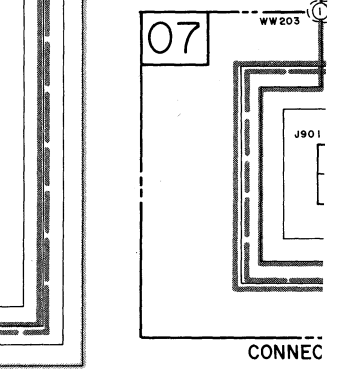

CONNEX

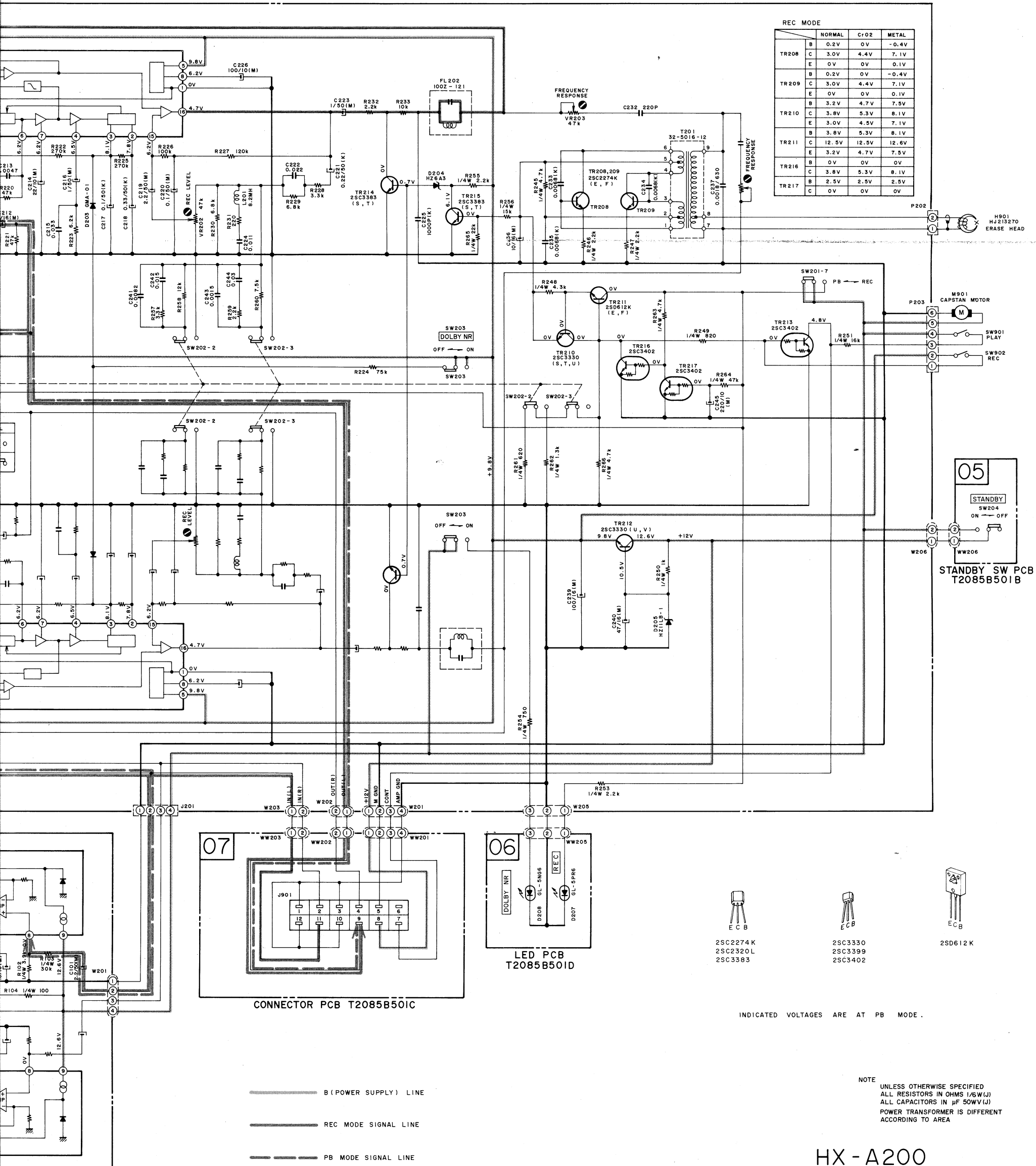

REC MODE

	NORMAL	CrO2	METAL
TR208	B 0.2V	0V	-0.4V
	C 3.0V	4.4V	7.1V
	E 0V	0V	0.1V
TR209	B 0.2V	0V	-0.4V
	C 3.0V	4.4V	7.1V
	E 0V	0V	0.1V
TR210	B 3.2V	4.7V	7.5V
	C 3.8V	5.3V	8.1V
	E 3.0V	4.5V	7.1V
TR211	B 3.8V	5.3V	8.1V
	C 12.5V	12.5V	12.6V
	E 3.2V	4.7V	7.5V
TR216	B 0V	0V	0V
	C 3.8V	5.3V	8.1V
	E 2.5V	2.5V	2.5V
TR217	B 0V	0V	0V
	C 0V	0V	0V
	E 0V	0V	0V

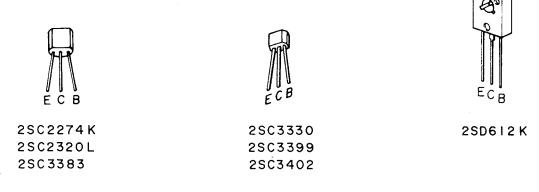
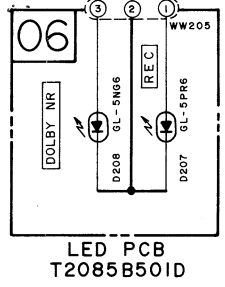
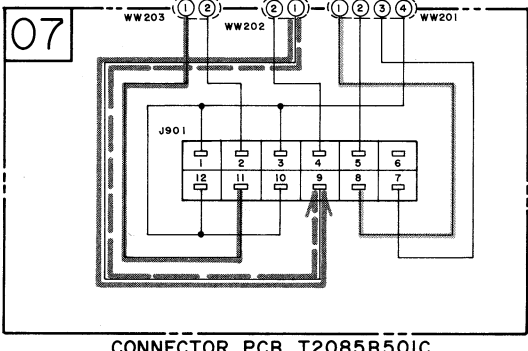
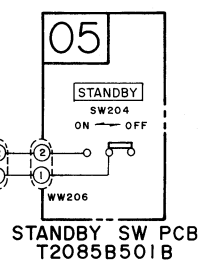

INDICATED VOLTAGES ARE AT PB MODE.

NOTE
 UNLESS OTHERWISE SPECIFIED
 ALL RESISTORS IN OHMS 1/6W(J)
 ALL CAPACITORS IN μF 50WV(J)
 POWER TRANSFORMER IS DIFFERENT
 ACCORDING TO AREA

HX-A200
 SCHEMATIC DIAGRAM
 No. 850612A

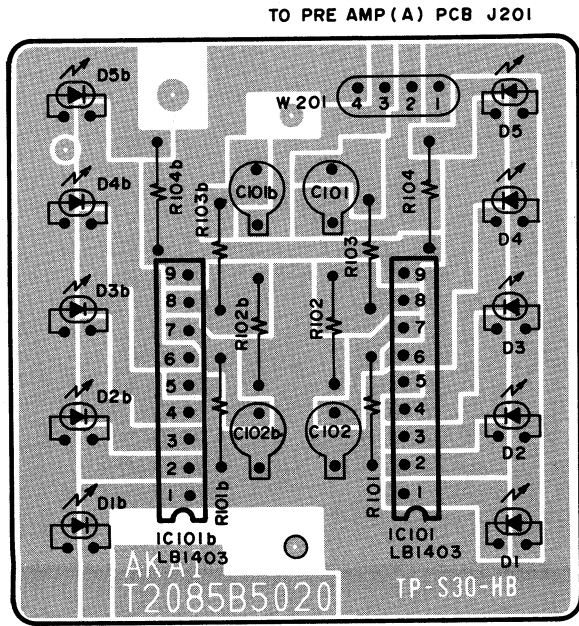

LEVEL METER PCB
T2085B5020

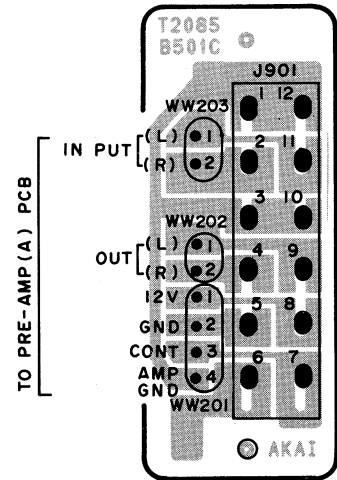

CONNECTOR PCB
T2085B501C

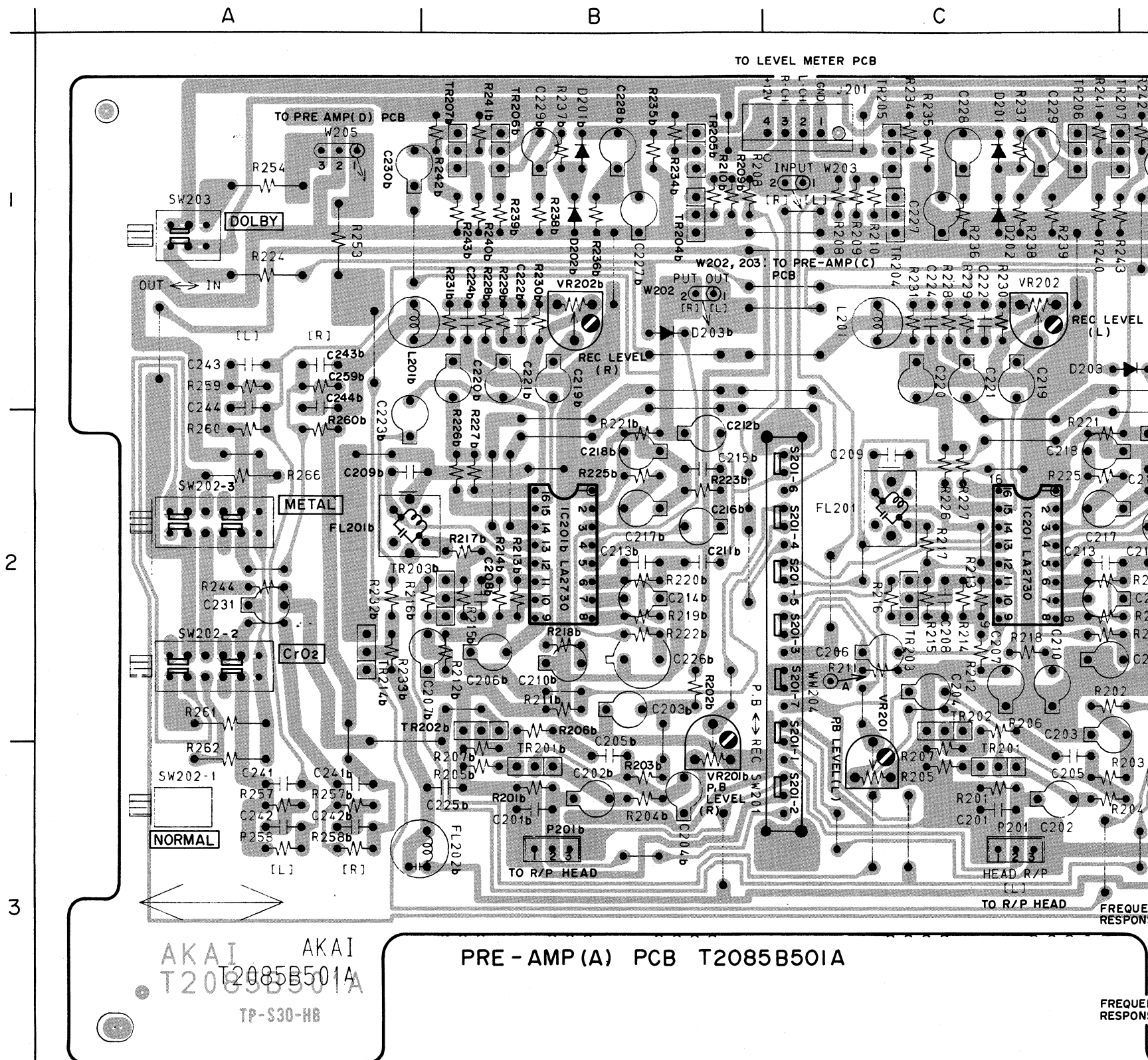

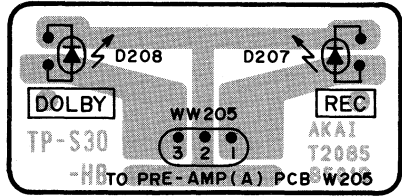

LED PCB
T2085B501D

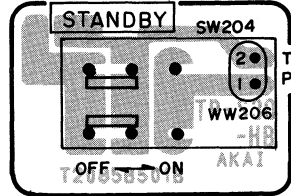

STANDBY SW PCB
T2085B501B

TO PRE-AMP (A)
PCB W206

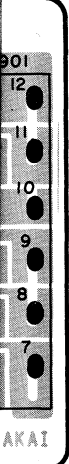

TOR PCB
501C

C

D

METER PCB

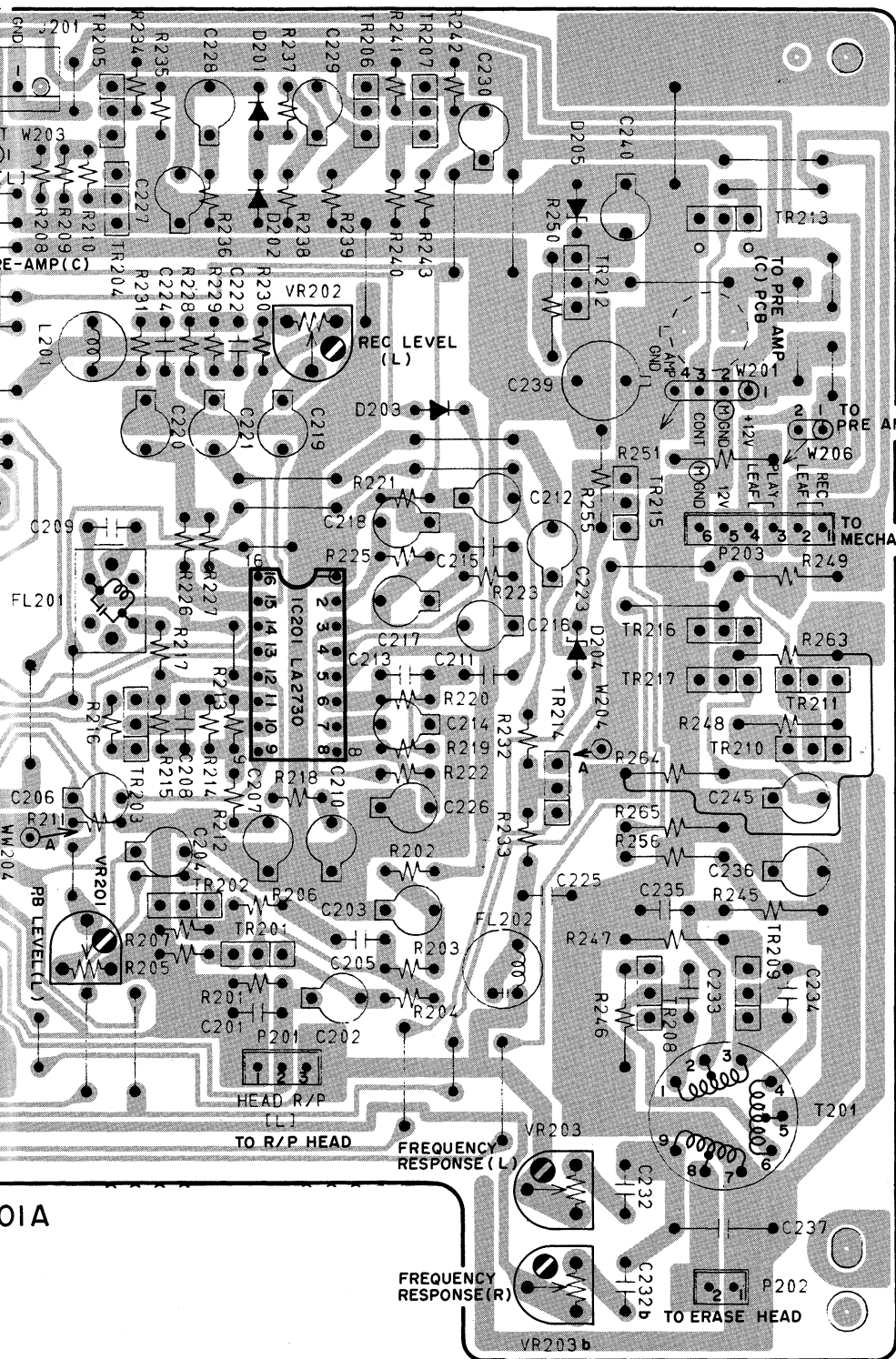

LOCATION OF COMPONENTS

- TRs
 TR201.....C3
 TR201b.....B3
 TR202, 203.....C2
 TR202b, 203b.....B2
 TR204, 205, 206.....C1
 TR207.....D1
 TR204b, 205b, 206b, 207b..B1
 TR208, 209.....D3
 TR210, 211.....D2
 TR212, 213.....D1
 TR214, 215, 216, 217.....D2
 TR214b.....A2

- ICs
 IC201.....C2
 IC201b.....B2

- CONNECTORS
 J201.....C1
 W201.....D1
 W202.....B1
 W203.....C1
 W205.....A1
 W206.....D1
 P201.....C3
 P201b.....B3
 P202.....D3
 P203.....D2

- TR201.....2SC2320L (F,G)
 TR202.....2SC3399
 TR203 to 207, 214, 215...2SC3383 (S,T)
 TR208, 209.....2SC2274K (E,F)
 TR210, 212.....2SC3330 (S,T,U)
 TR211.....2SD612K (E,F)
 TR213, 216, 217.....2SC3402

••• = NPN TRANSISTOR

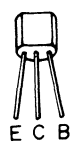

ECB



ECB



ECB

- 2SC2274K
 2SC2320L
 2SC3383

- 2SC3330
 2SC3399
 2SC3402

- 2SD612K

HX - A 300W

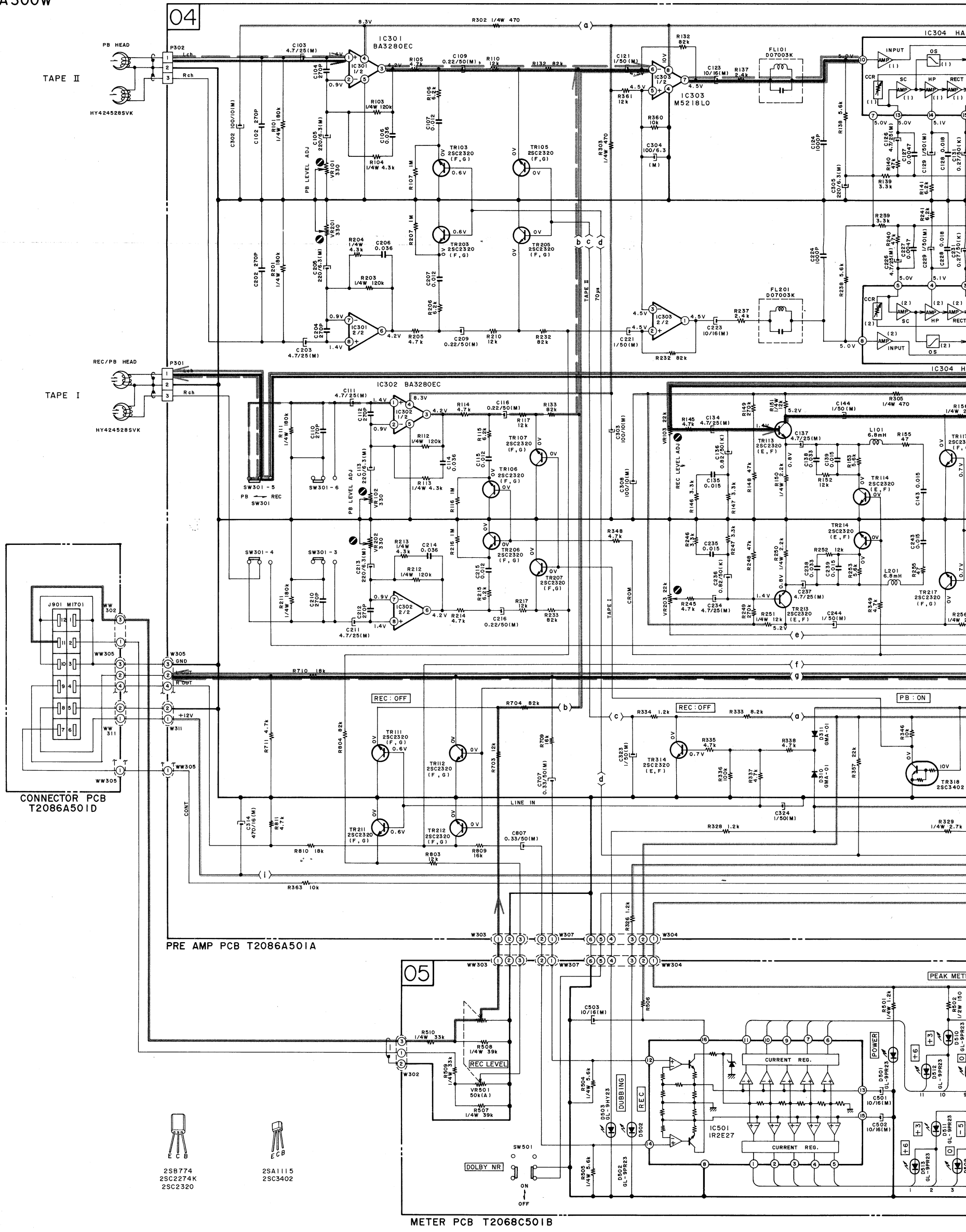

F

G

H

I

J

K

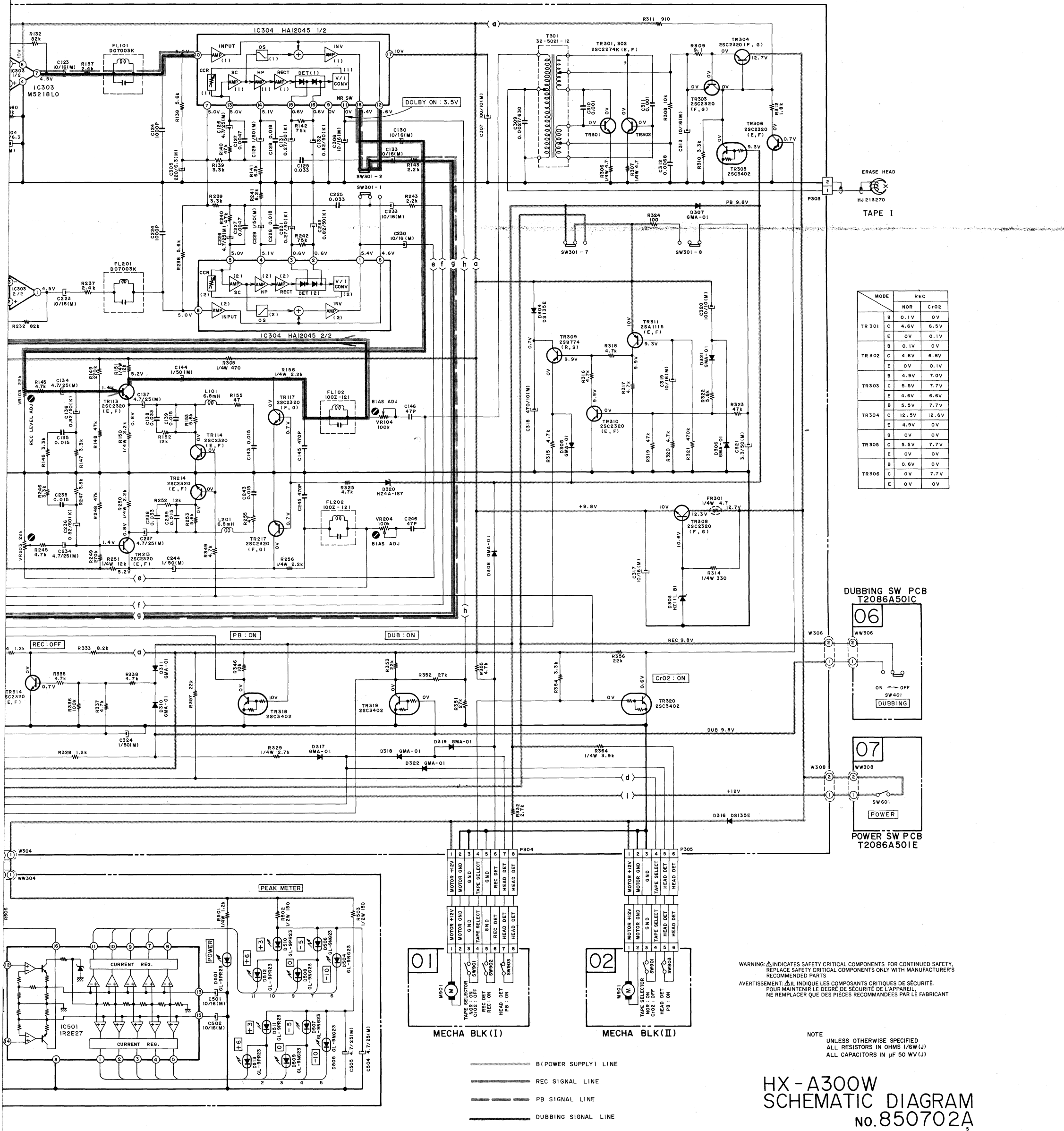

	MODE		REC	
	NOR	CrO2		
TR 301	B	0.1V	OV	
	C	4.6V	6.5V	
	E	OV	0.1V	
TR 302	B	0.1V	OV	
	C	4.6V	6.6V	
	E	OV	0.1V	
TR 303	B	4.9V	7.0V	
	C	5.5V	7.7V	
	E	4.6V	6.6V	
TR 304	B	5.5V	7.7V	
	C	12.5V	12.6V	
	E	4.9V	OV	
TR 305	B	OV	OV	
	C	5.5V	7.7V	
	E	OV	OV	
TR 306	B	0.6V	OV	
	C	OV	7.7V	
	E	OV	OV	

WARNING: Δ INDICATES SAFETY CRITICAL COMPONENTS FOR CONTINUED SAFETY. REPLACE SAFETY CRITICAL COMPONENTS ONLY WITH MANUFACTURER'S RECOMMENDED PARTS.
 AVERTISSEMENT: Δ IL INDIQUE LES COMPOSANTS CRITIQUES DE SÉCURITÉ. POUR MAINTENIR LE DEGRÉ DE SÉCURITÉ DE L'APPAREIL, NE REMPLACER QUE DES PIÈCES RECOMMANDÉES PAR LE FABRICANT.

NOTE
 UNLESS OTHERWISE SPECIFIED
 ALL RESISTORS IN OHMS 1/5W (J)
 ALL CAPACITORS IN μF 50 WV (J)

HX-A300W SCHEMATIC DIAGRAM No. 850702A

- B (POWER SUPPLY) LINE
- REC SIGNAL LINE
- PB SIGNAL LINE
- DUBBING SIGNAL LINE

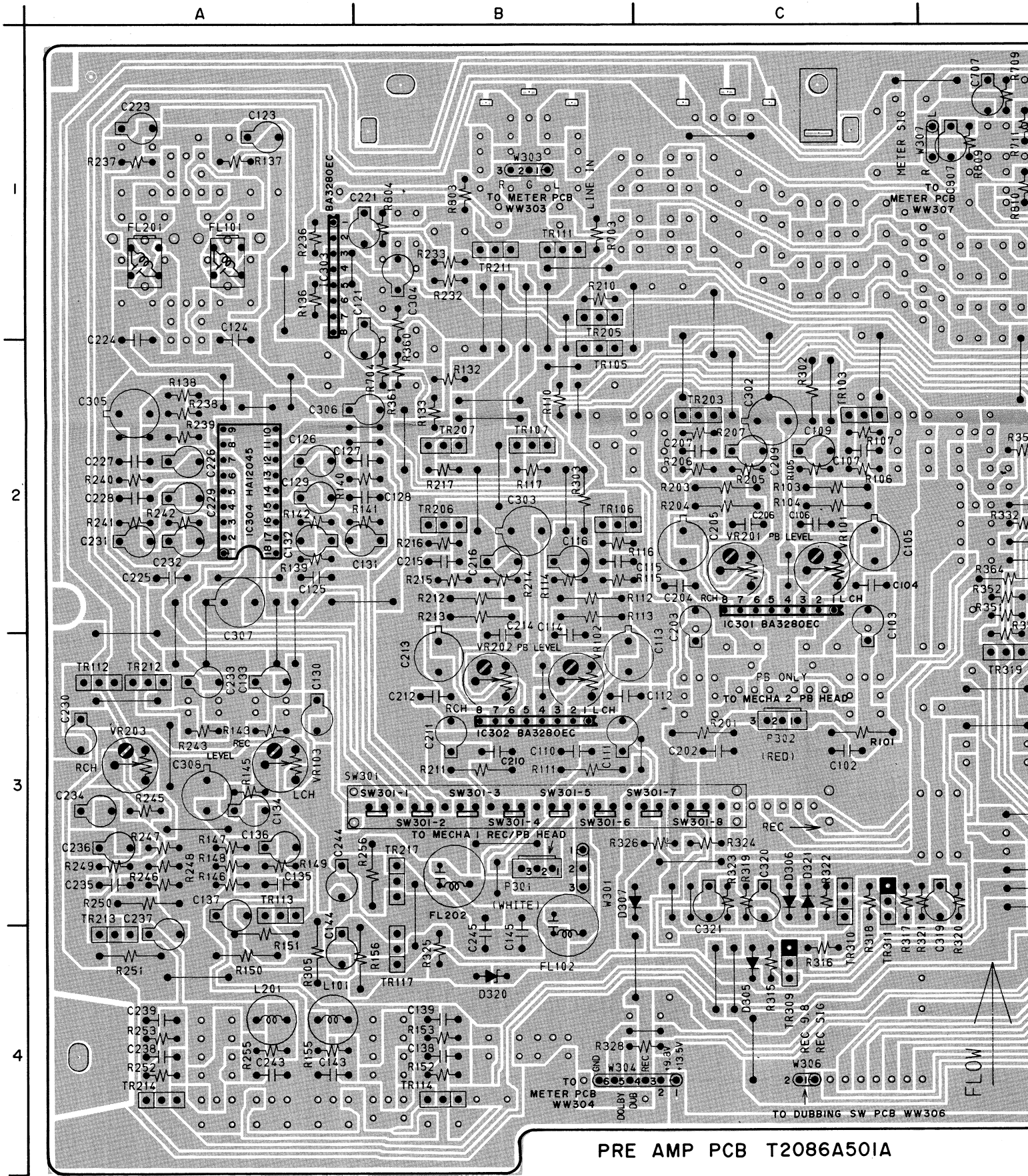

PRE AMP PCB T2086A501A

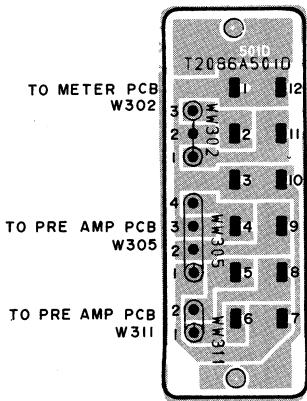

CONNECTOR PCB T2086A501D

WARNING: Δ INDICATES SAFETY CRITICAL COMPONENTS. FOR CONTINUED SAFETY, REPLACE SAFETY CRITICAL COMPONENTS ONLY WITH MANUFACTURER'S RECOMMENDED PARTS.
 AVERTISSEMENT: Δ IL INDIQUE LES COMPOSANTS CRITIQUES DE SÉCURITÉ. POUR MAINTENIR LE DEGRÉ DE SÉCURITÉ DE L'APPAREIL, NE REMPLACER QUE DES PIÈCES RECOMMANDÉES PAR LE FABRICANT.

\square = NPN TRANSISTORS
 \blacksquare = PNP TRANSISTORS

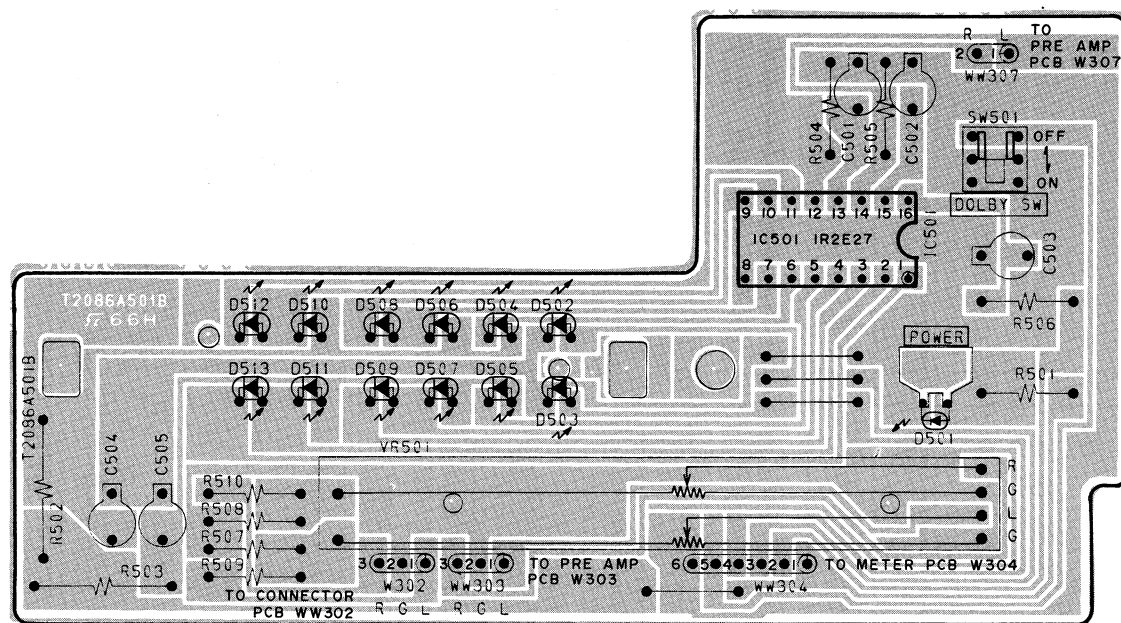

METER PCB T2086A501B

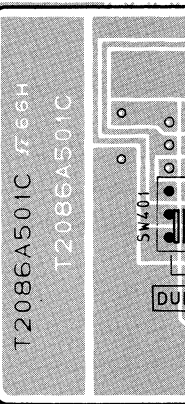

DUBBING SW PCB WW306

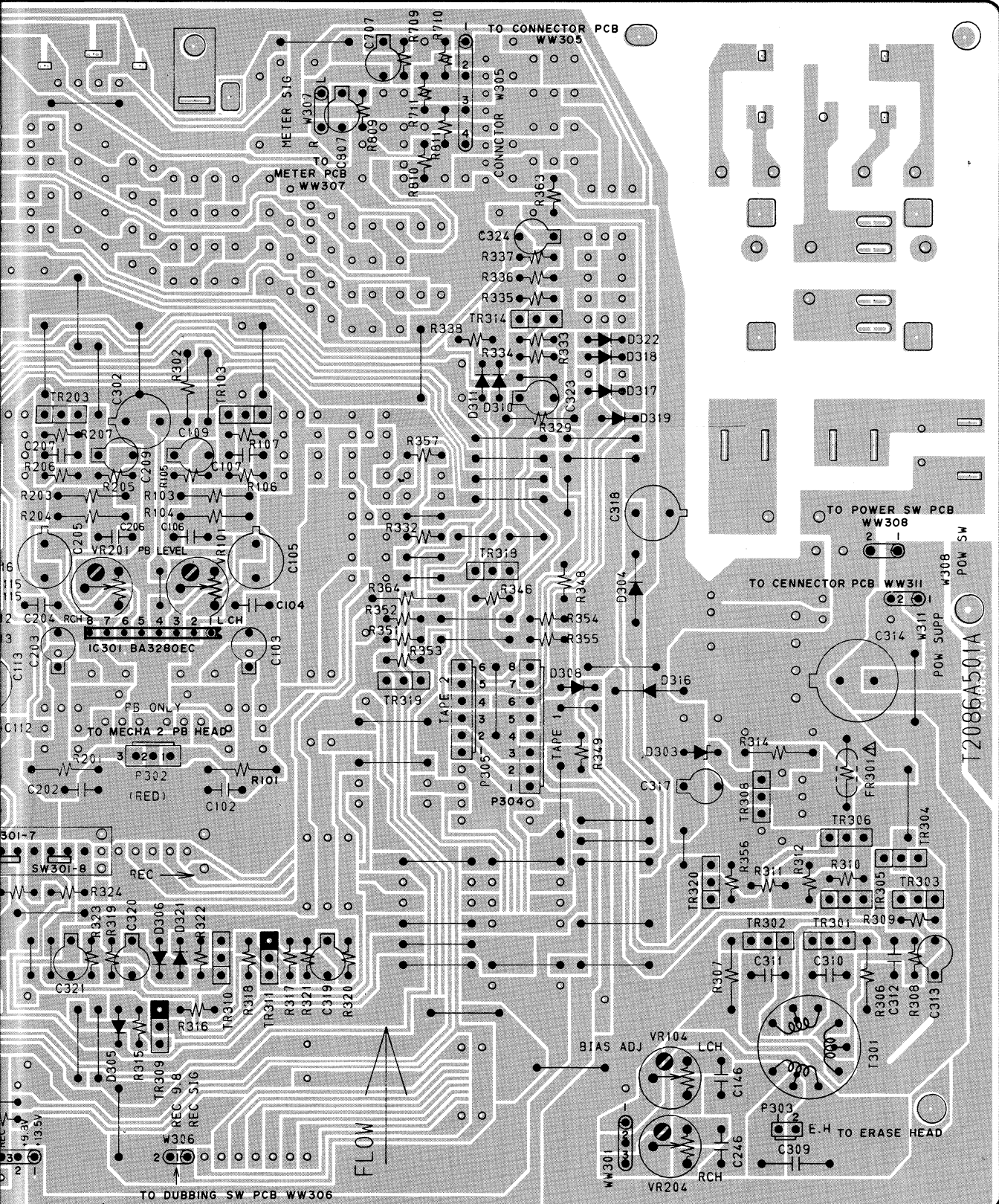

LOCATION OF COMPONENTS

- ICs
 IC301.....C2
 IC302.....B3
 IC303.....A1
 IC304.....A2

- TRs
 TR103.....C2
 TR105.....B2
 TR106.....B2
 TR107.....B2
 TR111.....B1
 TR112.....A3
 TR113.....A3
 TR114.....B4
 TR117.....B4
 TR203.....C2
 TR205.....B1
 TR206.....B2
 TR207.....B2
 TR211.....B1
 TR212.....A3
 TR213.....A4
 TR214.....A4
 TR217.....B3
 TR401.....E3
 TR302.....E3
 TR303.....E3
 TR304.....E3
 TR305.....E3
 TR306.....E3
 TR308.....E3
 TR309.....C4
 TR310.....C3
 TR311.....C3
 TR314.....D1
 TR318.....D2
 TR319.....D3
 TR320.....E3

- TR103.....2SC2320 (F,G)
 TR105.....2SC2320 (F,G)
 TR106.....2SC2320 (F,G)
 TR107.....2SC2320 (F,G)
 TR111.....2SC2320 (F,G)
 TR112.....2SC2320 (F,G)
 TR113.....2SC2320 (E,F)
 TR114.....2SC2320 (E,F)
 TR117.....2SC2320 (F,G)
 TR203.....2SC2320 (F,G)
 TR205.....2SC2320 (F,G)
 TR206.....2SC2320 (F,G)
 TR207.....2SC2320 (F,G)
 TR211.....2SC2320 (F,G)
 TR212.....2SC2320 (F,G)
 TR213.....2SC2320 (E,F)
 TR214.....2SC2320 (E,F)
 TR217.....2SC2320 (F,G)
 TR301.....2SC2274K (E,F)
 TR302.....2SC2274K (E,F)
 TR303.....2SC2320 (F,G)
 TR304.....2SC2320 (F,G)
 TR305.....2SC3402
 TR306.....2SC2320 (F,G)
 TR308.....2SC2320 (F,G)
 TR309.....2SB774 (E,F)
 TR310.....2SC2320 (E,F)
 TR311.....2SA1115 (E,F)
 TR314.....2SC2320 (E,F)
 TR318.....2SC3402
 TR319.....2SC3402
 TR320.....2SC3402

AMP PCB T2086A501A

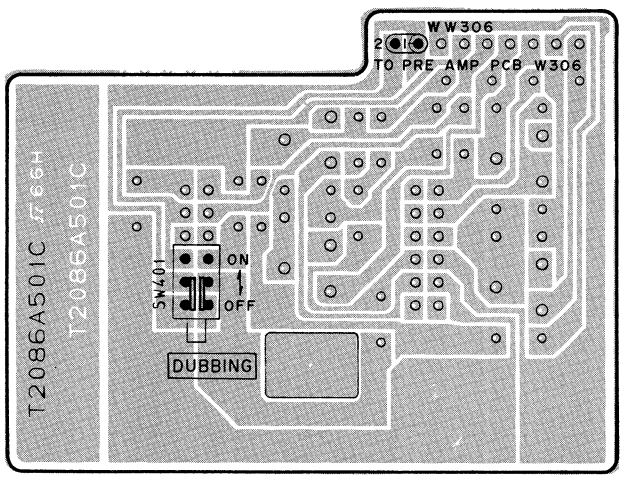
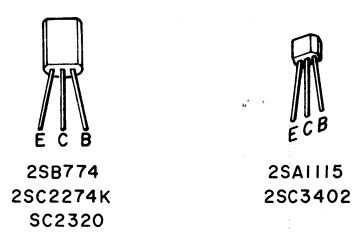
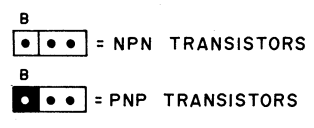

DUBBING PCB T2086A501C

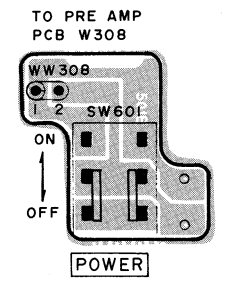

POWER SW PCB T2086A501E

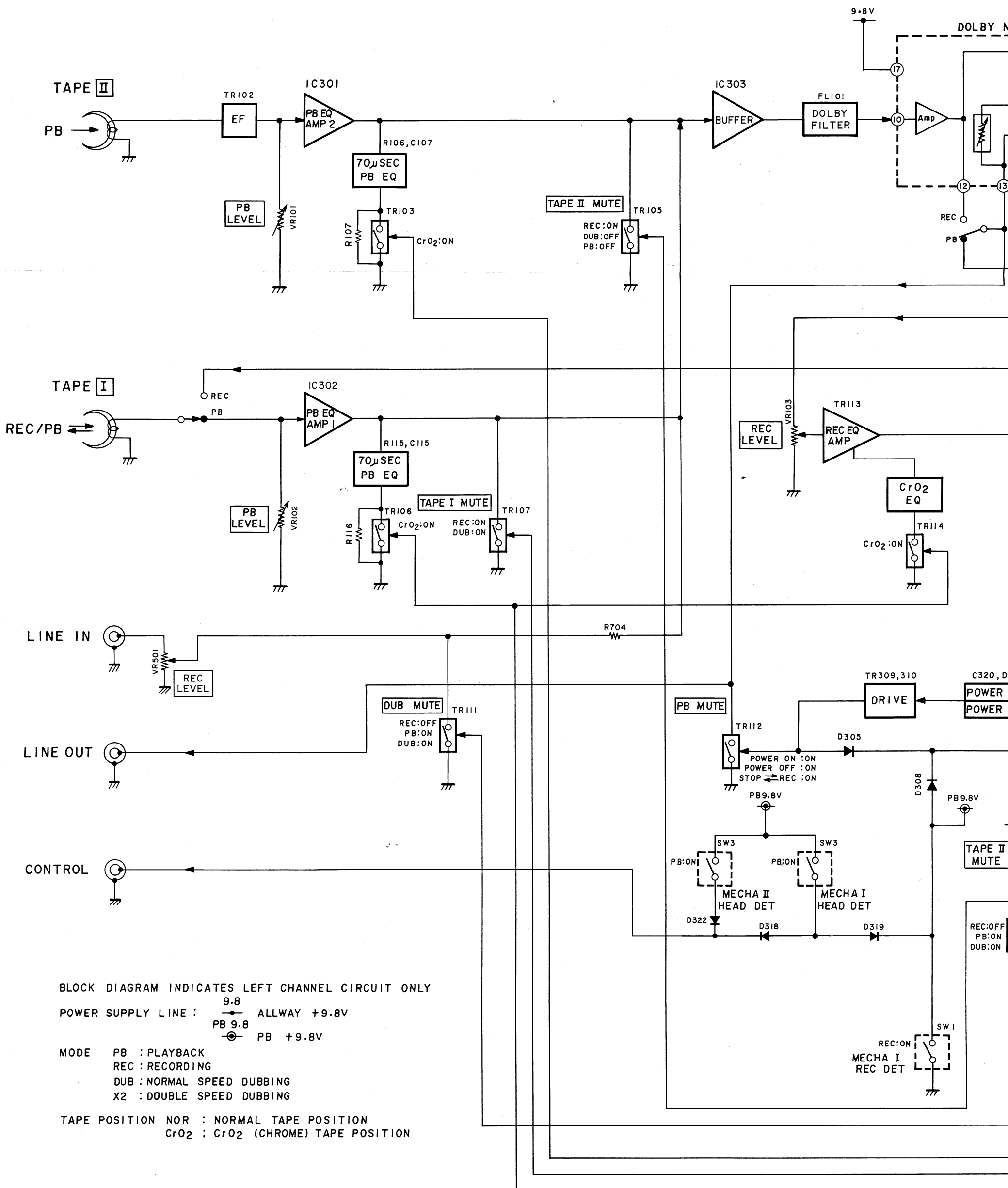

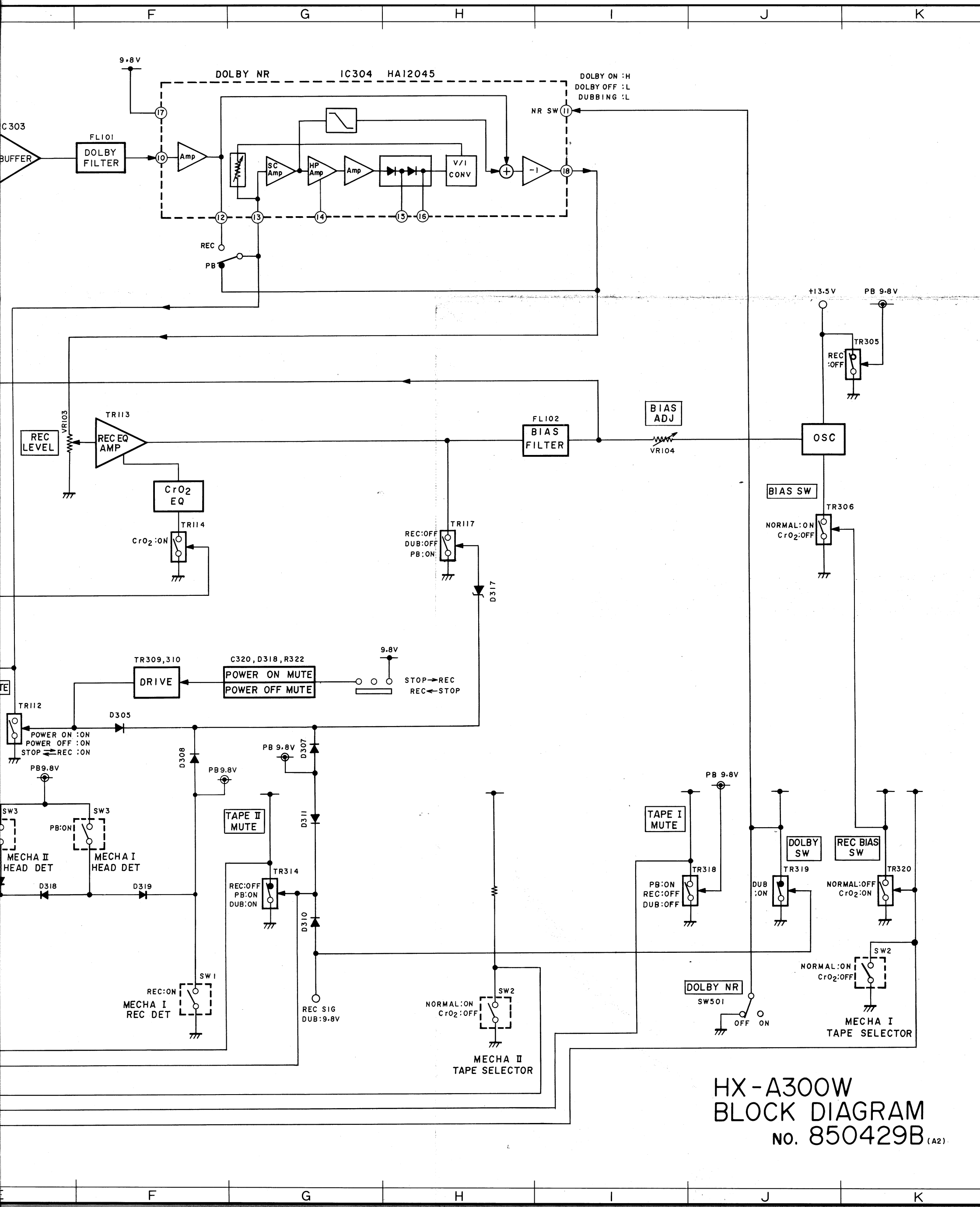

HX-A300W
 BLOCK DIAGRAM
 No. 850429B (A2)