

# SERVICE MANUAL

# PARTS LIST

PRIDE IN QUALITY

**AKAI CASSETTE TAPE DECK**

MODEL **CS-33D**

**ALSO APPLICABLE TO MODEL CS-30, CS-30D**



## CASSETTE STEREO TAPE DECK

### MODEL **CS-33D**

ALSO APPLICABLE TO MODEL CS-30 CASSETTE  
STEREO TAPE RECORDER & MODEL CS-30D  
CASSETTE STEREO TAPE DECK

SECTION 1	SERVICE MANUAL . . . . .	3
SECTION 2	PARTS LIST . . . . .	15
SECTION 3	CONNECTION DIAGRAM . . . . .	32
SECTION 4	SCHEMATIC DIAGRAM . . . . .	36

## SECTION 1

# SERVICE MANUAL

### TABLE OF CONTENTS

<b>I.</b>	<b>SPECIFICATIONS</b> .....	<b>4</b>
<b>II.</b>	<b>MEASURING METHOD</b> .....	<b>5</b>
	1. TAPE SPEED DEVIATION .....	5
	2. WOW AND FLUTTER .....	5
	3. FREQUENCY RESPONSE .....	5
	4. SIGNAL TO NOISE RATIO .....	5
	5. TOTAL HARMONIC DISTORTION FACTOR .....	6
	6. CROSS TALK .....	6
	7. ERASE RATIO .....	6
	8. POWER OUTPUT .....	6
<b>III.</b>	<b>DISMANTLING OF UNIT</b> .....	<b>7</b>
<b>IV.</b>	<b>MECHANISM ADJUSTMENTS</b> .....	<b>8</b>
	1. FLYWHEEL LOOSE PLAY ADJUSTMENT .....	8
	2. TAKE-UP TORQUE AT VARIOUS MODES AND TORQUE MEASURING METHOD .....	8
	3. PINCH WHEEL PRESSURE MEASURING METHOD .....	8
<b>V.</b>	<b>HEAD ADJUSTMENT</b> .....	<b>9</b>
<b>VI.</b>	<b>AMPLIFIER ADJUSTMENTS</b> .....	<b>10</b>
	1. PRE AMPLIFIER BLOCK DIAGRAM .....	10
	2. PLAYBACK LEVEL ADJUSTMENT .....	11
	3. RECORDING LEVEL ADJUSTMENT .....	11
	4. FREQUENCY RESPONSE ADJUSTMENT .....	12
	5. RECORDING BIAS FREQUENCY MEASUREMENT .....	12
	6. RECORDING BIAS VOLTAGE AND ERASE VOLTAGE MEASUREMENT .....	12
	7. DOLBY AMPLIFIER ADJUSTMENT .....	12
<b>VII.</b>	<b>D.C. RESISTANCE OF EACH COIL</b> .....	<b>14</b>

# I. SPECIFICATIONS

An asterisk next to a figure indicates the minimum guaranteed performance.

TRACK SYSTEM	4-track 2-channel system	
TAPE SPEED	1-7/8 ips. (4.75 cm/sec.)±3%	
WOW AND FLUTTER	Less than 0.15% (*0.3%) W.R.M.S.	
TOTAL WOW AND FLUTTER	Less than 0.35% W.R.M.S. (3,000 Hz recording and playback)	
FREQUENCY RESPONSE	Chrome Tape	40 to 15,000 Hz (*40 to 14,000 Hz±3 dB)
	Low Noise Tape	40 to 13,000 Hz (*40 to 12,000 Hz±3 dB)
TOTAL DISTORTION FACTOR	Less than 3% at 1,000 Hz 0 VU recording	
OUTPUTS	Line Output	0(0.775V)±1.5 dB, using a 333 Hz 0 VU recorded tape
	Din Output	0.6V
	Phone Output	30 mV at 8Ω
	Speaker Output	7W total music power at 8Ω } (Recorder type only) *2W each channel at 8Ω }
INPUTS	Mic Input	More than 0.5 mV Impedance: 4.7 kΩ
	Line Input	More than 50 mV(*70 mV) Impedance: 200 kΩ
	Din Input	More than 5 mV More than 3.5 mV (CEE models)
RECORDING/PLAYBACK LEVEL	0(0.775V)±2 dB	
SIGNAL TO NOISE RATIO	Better than 48 dB	
TOTAL SIGNAL TO NOISE RATIO	Better than 43 dB	
CROSS TALK	Better than 25 dB at 1,000 Hz 3 VU recording	
ERASE RATIO	Better than 65 dB	
BIAS FREQUENCY	63±5 kHz	
BIAS LEAK	Less than -20 VU	
HUM AND NOISE	Less than 10 mV (Recorder type only)	
RECORDING CAPACITY	1 hour stereo recording, using a C-60 cassette tape	
F. FWD AND RWD TIME	100 sec., using a C-60 cassette tape	
HEADS	Recording/Playback Head	4-track 2-channel Recording/Playback Head Type: P4-303 Gap: 1 micron Impedance: 1,050Ω±25% at 1 kHz D.C. Resistance: 110Ω
	Erase Head	2-track 1-channel Erase Head Type: AE-134 Impedance: 330Ω±15% at 50 kHz D.C. Resistance: 6Ω
MOTOR	Electronic Governor Motor Type: MHI-5R6B Revolutions: 2,200 r.p.m.	
TRANSISTORS AND FET	2SC711(E)(F) . . . 10 2SD360(D <sub>2</sub> )(E <sub>1</sub> ) . . . 2 Dolby N.R. Circuit 2SA564(Q) . . . 2 2SC458LG(C) . . . 6	2SC1312(G)(H) . . . 6   2SC458(C) . . . 6 2SK30(GR) . . . 2
DIODES	1N34A . . . 2 WG-599 . . . 3 WZ192 . . . 1 Dolby N.R. Circuit 1N34A . . . 4 WZ085 . . . 2	1N4001 . . . 12(Deck type: 8) WZ065 . . . 1  WG599 . . . 6
I.C.	LA-4032P . . . 2(Recorder type only)	
POWER SUPPLY	100V/120V 50 Hz/60 Hz A.C. for JPN and CSA models 120V 60 Hz A.C. for UL(LA) models 220V 50 Hz A.C. for CEE models (110V/220V A.C. and 240V A.C.)	
WEIGHT	4.8 kg(10.6 lbs.) CS-33D 4.9 kg(10.8 lbs.) CS-30 4.6 kg(10.1 lbs.) CS-30D	
POWER CONSUMPTION	12W . . . Recorder	10W . . . Deck
DIMENSIONS	410(W)×126(H)×220(D)mm (16.1"×5"×8.7")	

NOTE: Specifications subject to change without notice.



## II. MEASURING METHOD

### 1. TAPE SPEED DEVIATION

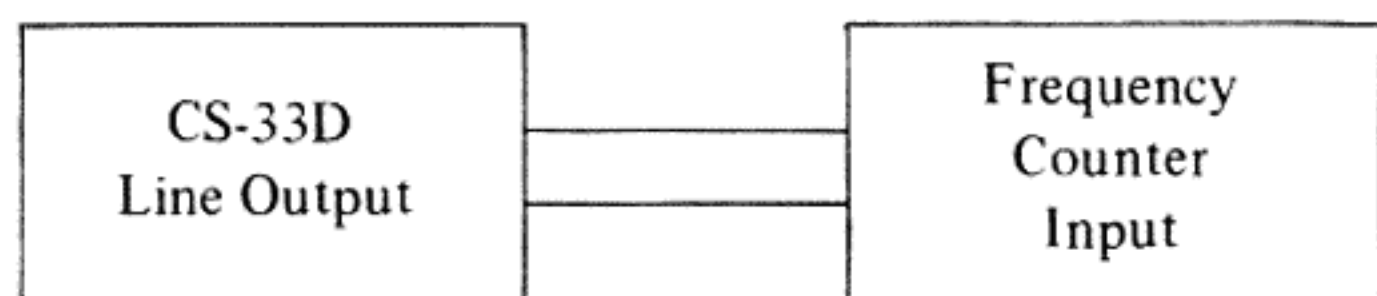

Fig. 1

As shown in Fig. 1, connect a Frequency Counter to the Line Output and playback a 1,000 Hz pre-recorded test tape. Take a Frequency Counter reading at the beginning, middle, and end of tape winding during playback. The maximum value of these respective readings will represent tape speed deviation.

### 2. WOW AND FLUTTER

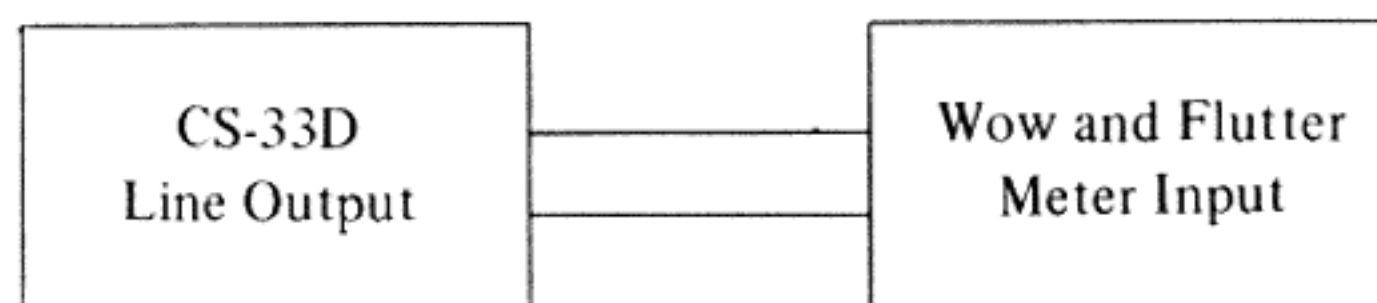

Fig. 2

#### Method A

As shown in Fig. 2, connect the Line Output to the Input of a Wow and Flutter Meter. Use a 3,000 Hz pre-recorded test tape and take a Wow and Flutter Meter reading at the beginning, middle, and end of tape winding. The maximum value of these respective readings will represent the Wow and Flutter.

#### Method B

Supply a 3,000 Hz sine wave signal from an Audio Frequency Oscillator and make a recording on a blank tape at the beginning, middle, and end of tape winding. Rewind and play tape. Measure Wow and Flutter Meter. (The Wow and Flutter value of Method B will be close to  $\sqrt{2}$  times the value of Method A.)

### 3. FREQUENCY RESPONSE

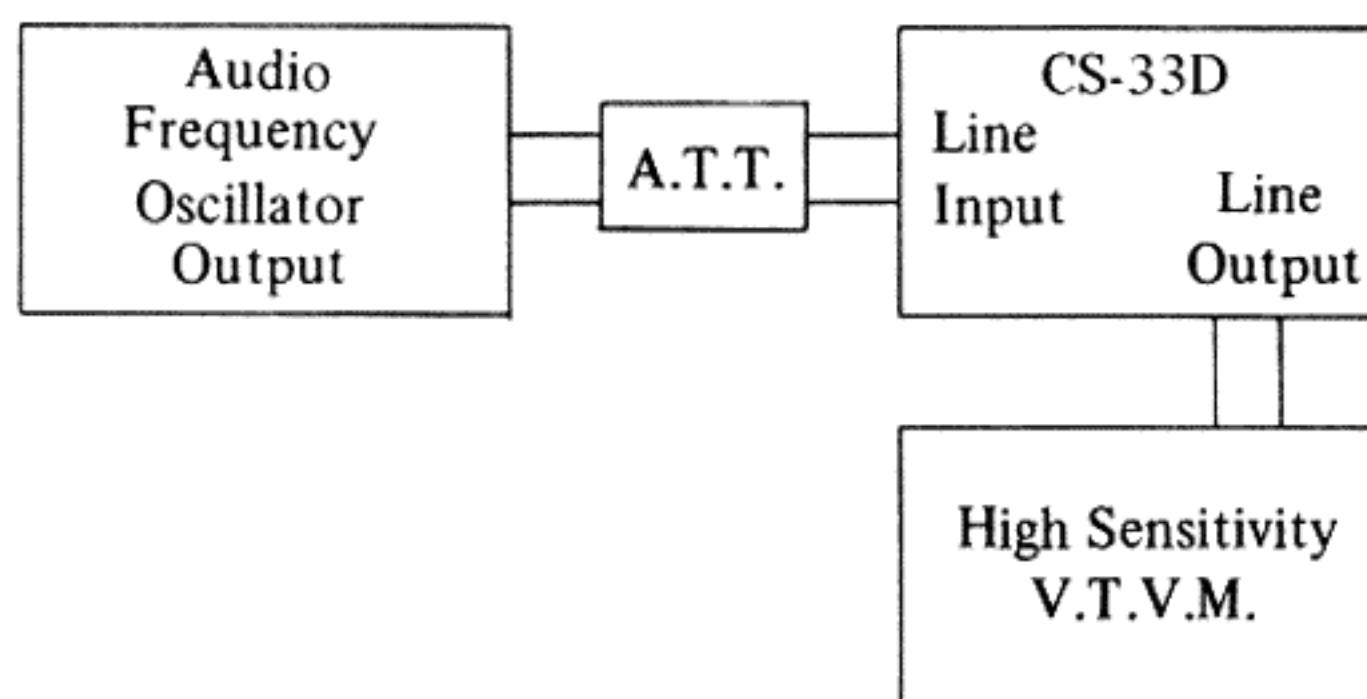

Fig. 3

For measuring Frequency Response, connect instruments as shown in Fig. 3 and proceed as follows:

- 1) Supply a 1,000 Hz sine wave to the Line Input from an Audio Frequency Oscillator through an Attenuator. Set recorder to recording mode and turn recording level control volume or volume control to maximum. Adjust Attenuator to obtain a 0 dB V.T.V.M. reading.
- 2) Under conditions described in 1) above, re-adjust Attenuator so that the Line Output is -20 dB, and record 40 to 13,000 Hz spot frequencies.
- 3) Rewind the tape and playback from the beginning. Take V.T.V.M. spot frequency readings and plot values on a graph.

NOTE: When measuring Frequency Response, new tape should be used.

### 4. SIGNAL TO NOISE RATIO

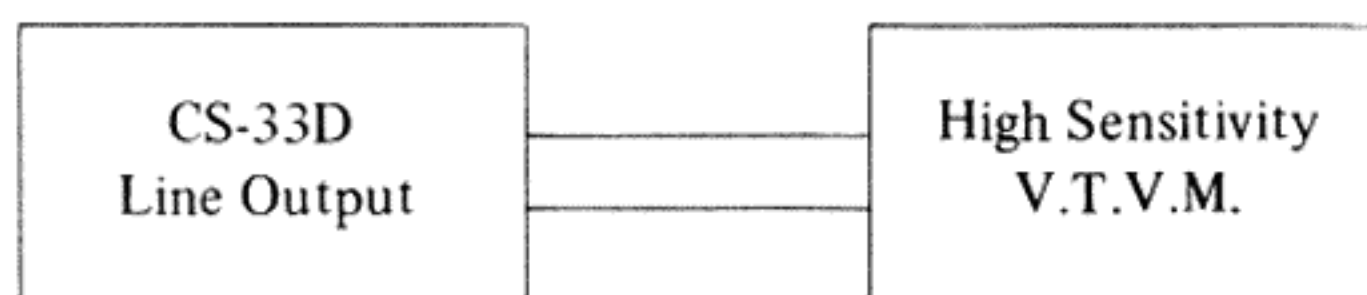

Fig. 4

As shown in Fig. 4, connect a High Sensitivity V.T.V.M. to the Line Output. Playback a 333 Hz "0" VU pre-recorded test tape and measure the output. Then remove the tape and measure the noise level under the same condition. Convert each of the measured values into decibels.

## 5. TOTAL HARMONIC DISTORTION FACTOR

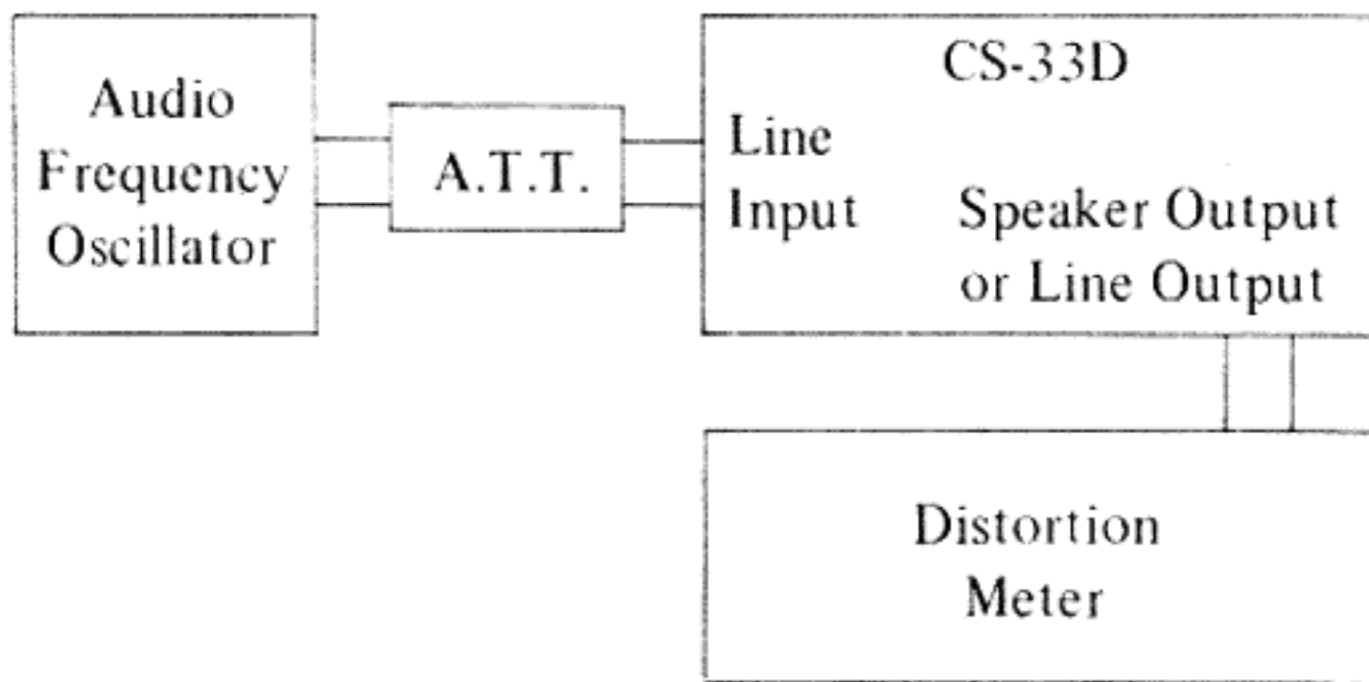

Fig. 5

Connect the measuring instruments as shown in Fig. 5 and record a 1,000 Hz sine wave signal at "0" VU. Playback the resultant signal and measure the overall distortion factor.

- NOTE: 1) At this time, Distortion of the Audio Frequency Oscillator must be sufficiently small.  
 2) When measuring the distortion factor, new tape should be used.

## 6. CROSS TALK (Cross Talk between the Tracks)

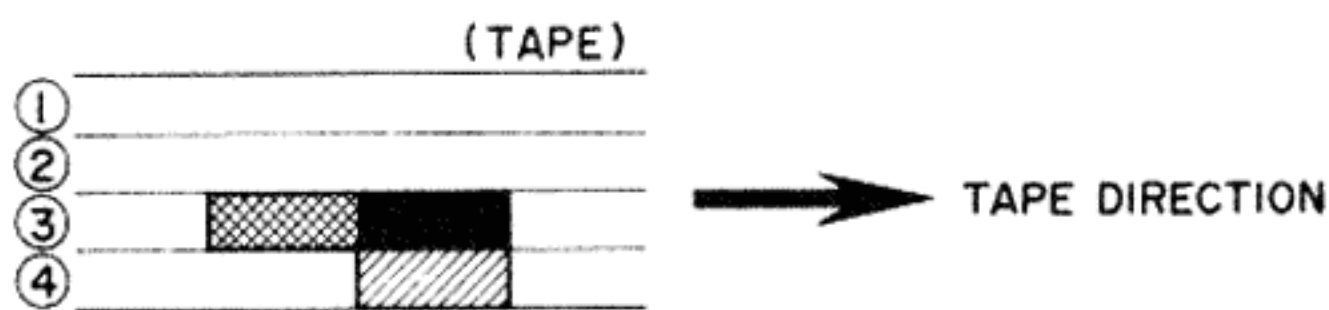

Fig. 6

As shown in Fig. 6, first record a 1,000 Hz sine wave signal on Track No. 3 at +3 VU level. Next, record under a non-input condition. Then, playback the tape on Tracks No. 3 and 4 through the B.P.F. (band pass filter sensitivity . . . 1:1) and obtain a ratio between the two from the following formula:

$$C = 20 \log \frac{E_0}{E_2 - E_1} \text{ (dB)}$$

- where, C = Desired cross talk ratio (dB)  
 $E_0$  = 1,000 Hz signal output level (solid black)  
 $E_2$  = 1,000 Hz cross talk level (hatched)  
 $E_1$  = Non-input signal recorded level (cross-hatched)

## 7. ERASE RATIO

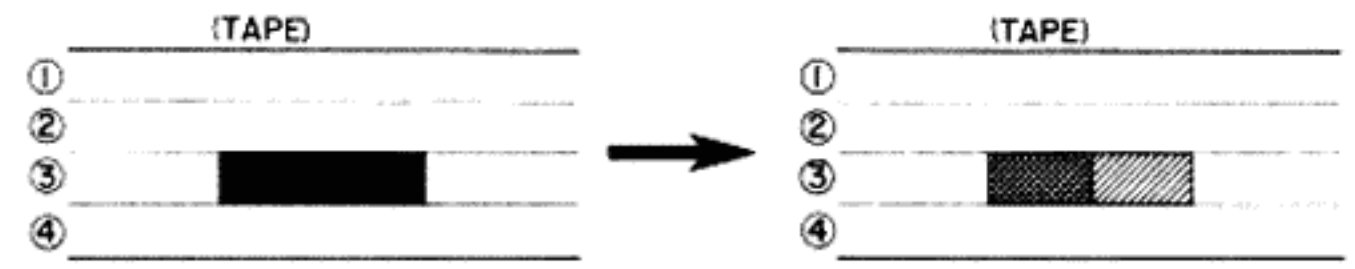

Fig. 7

As shown in Fig. 7, connect a High Sensitivity V.T.V.M. to the Line Output. Playback a virgin tape and take a V.T.V.M. reading of the output level. Next, record a 1,000 Hz sine wave signal at +3 VU, then playback this recorded signal and take a V.T.V.M. reading of the output level. Next, using this pre-recorded tape, record under a non-input condition and take a reading of the noise level output of the erased signal and obtain a ratio between the two from the following formula:

$$Er = 20 \log \frac{E_0}{E_2 - E_1} \text{ (dB)}$$

- where,  $Er$  = Desired erase ratio (dB)  
 $E_0$  = 1,000 Hz signal output level (solid black)  
 $E_2$  = Erased 1,000 Hz signal and noise level (V) (hatched)  
 $E_1$  = Virgin tape noise output level (cross-hatched)

## 8. POWER OUTPUT



Fig. 8

As shown in Fig. 8, connect an 8Ω dummy load resistor to the Speaker Output and connect this terminal to a High Sensitivity V.T.V.M. Playback a 1,000 Hz "0" VU pre-recorded test tape and take a V.T.V.M. reading of the output level. The resultant output can be obtained from the results of the above measurement by using the following formula:

$$P = \frac{E^2}{R} \text{ (W)}$$

- where, P = Desired power output (watts)  
 $E$  = Measured voltage (R.M.S.)  
 $R = 8\Omega$



### III. DISMANTLING OF UNIT

---

In case of trouble, etc. necessitating disassembly, please disassemble in the order shown in photographs. Re-assemble in reverse order.

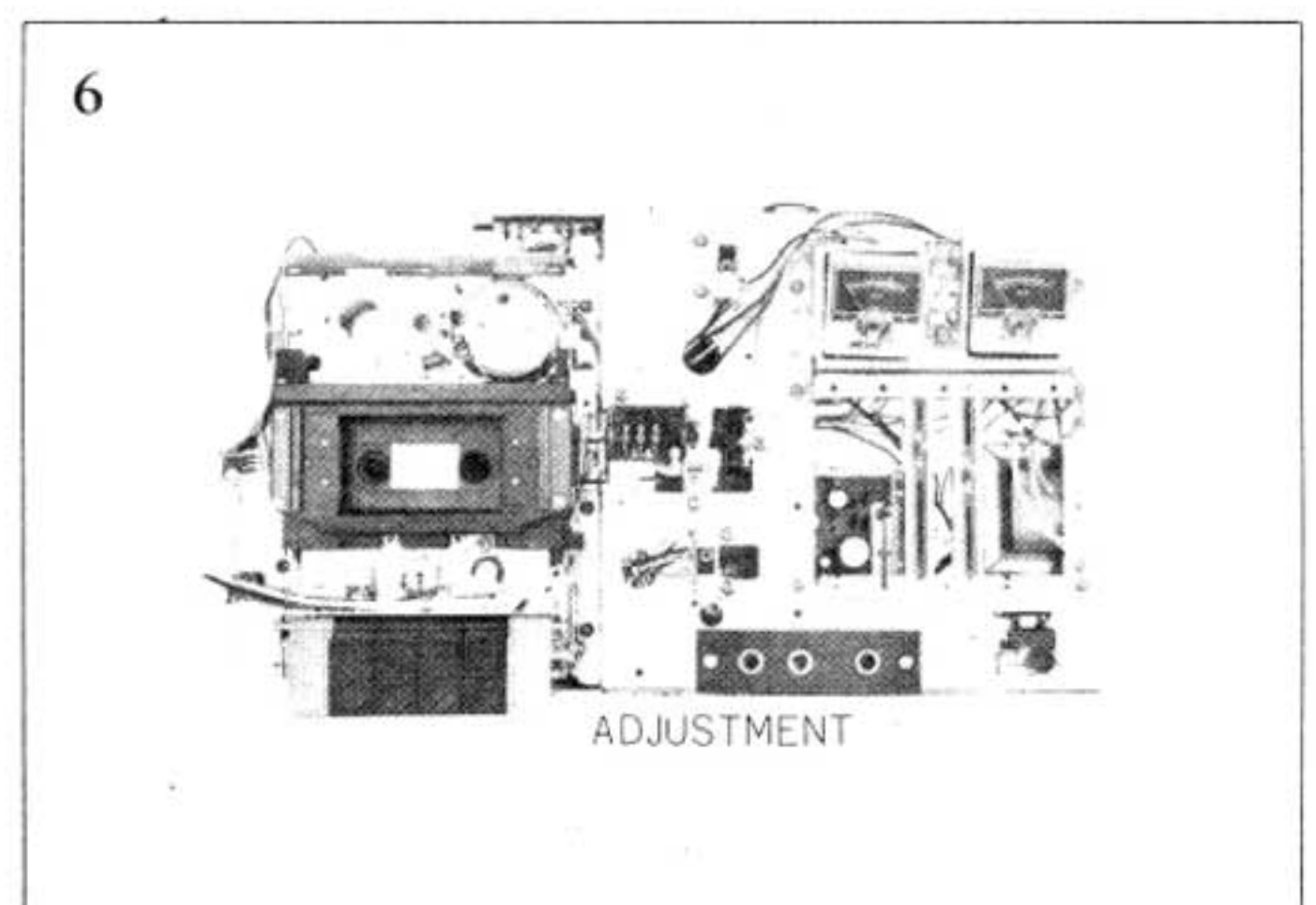
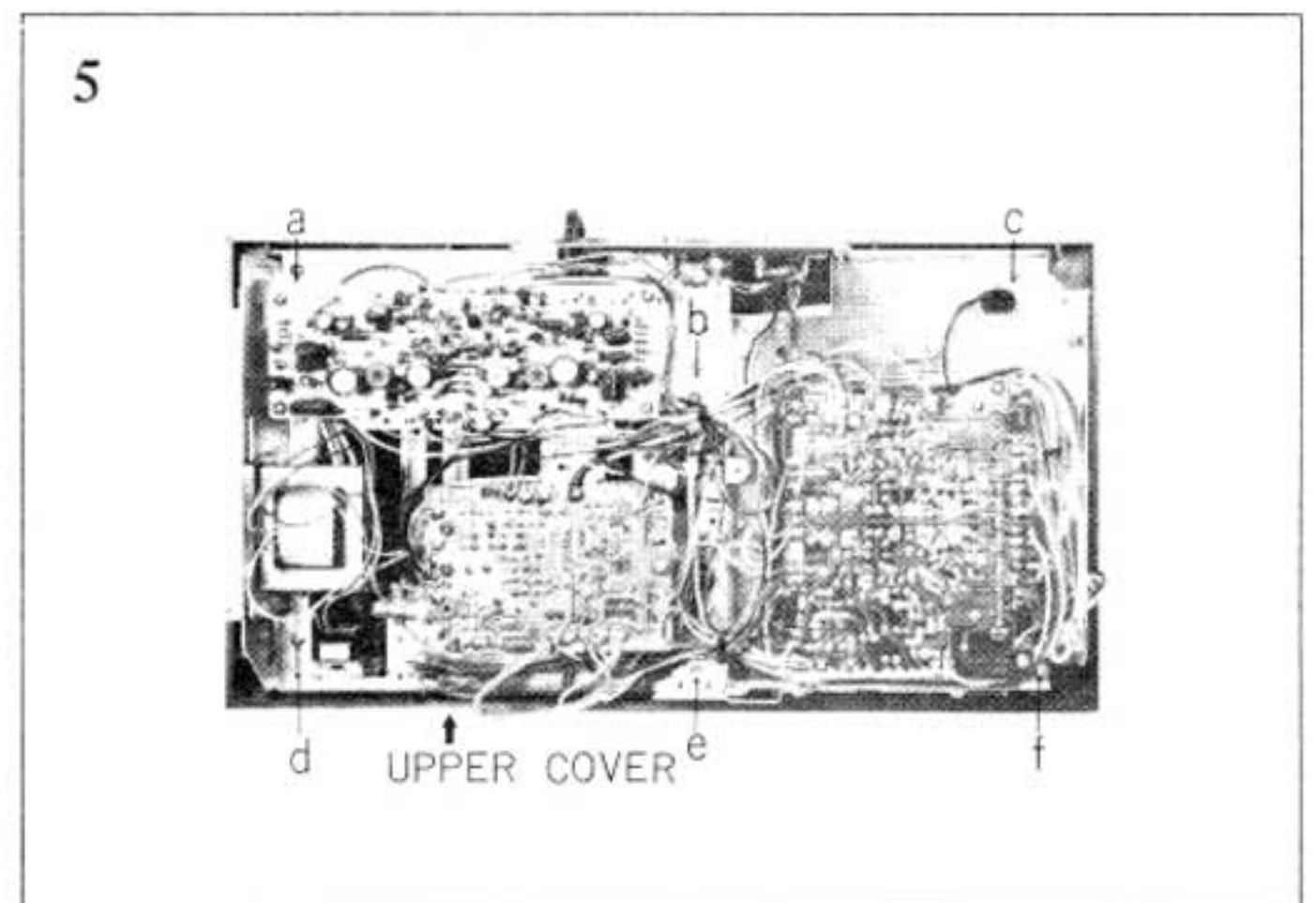
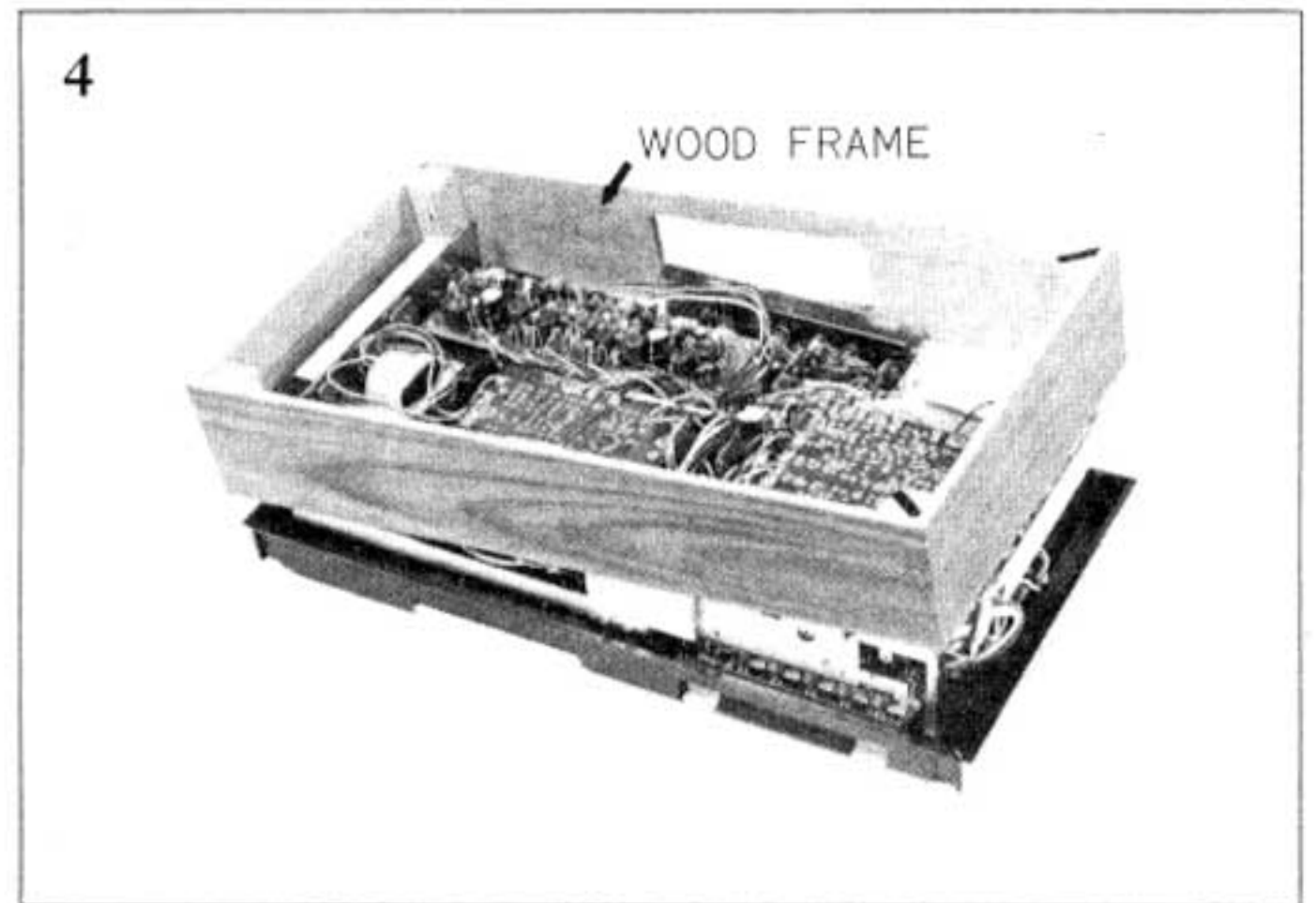
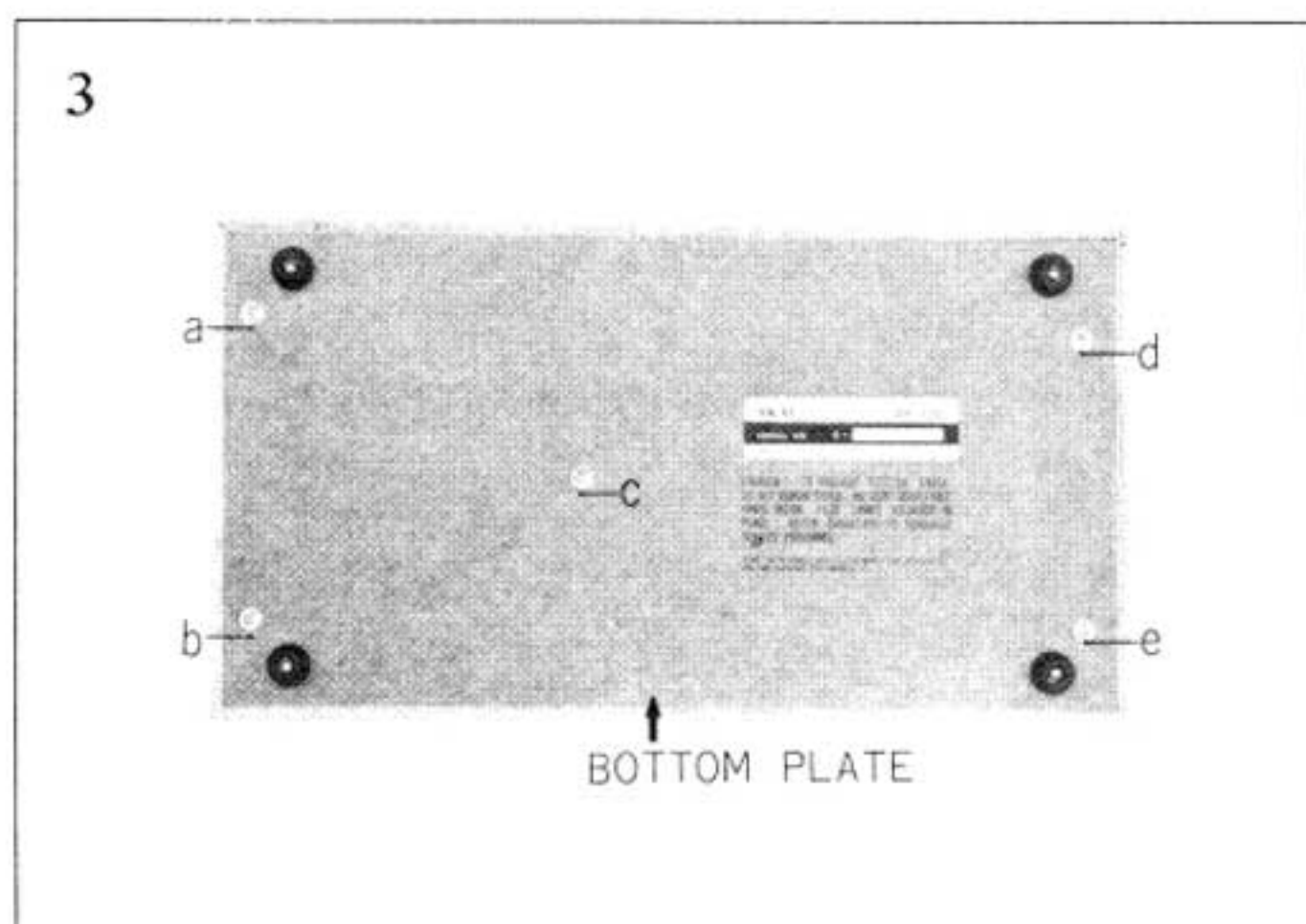
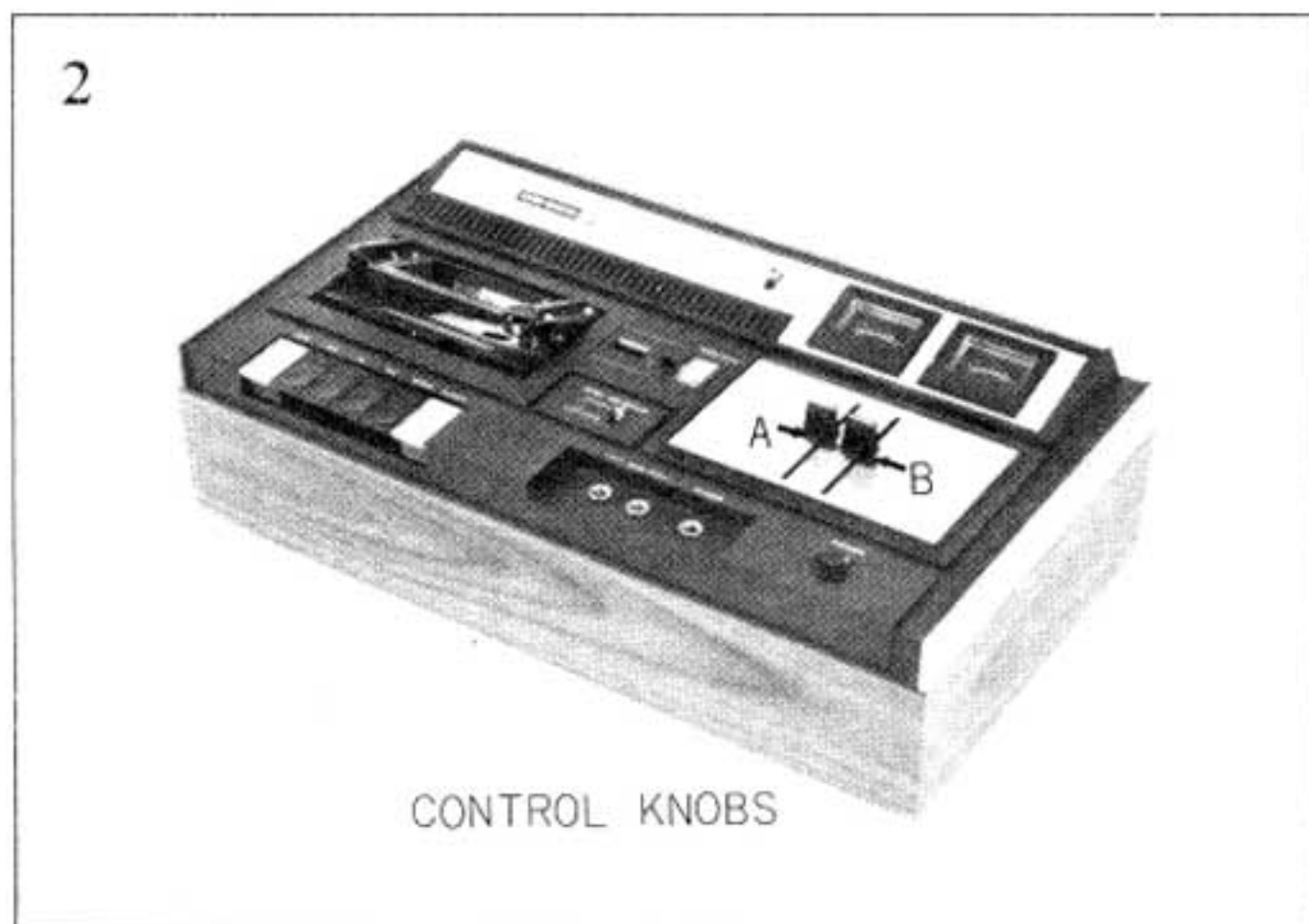
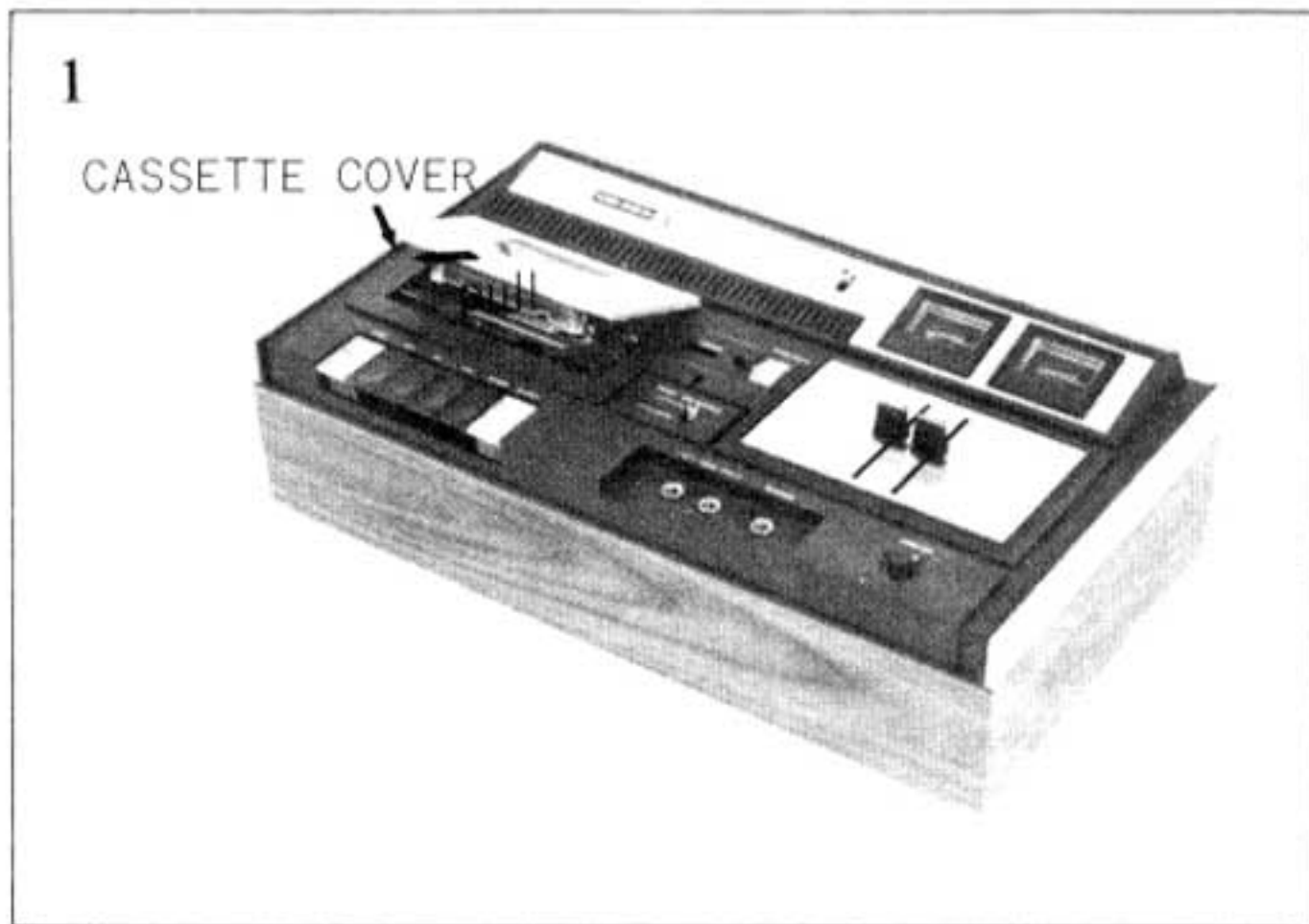

## IV. MECHANISM ADJUSTMENTS

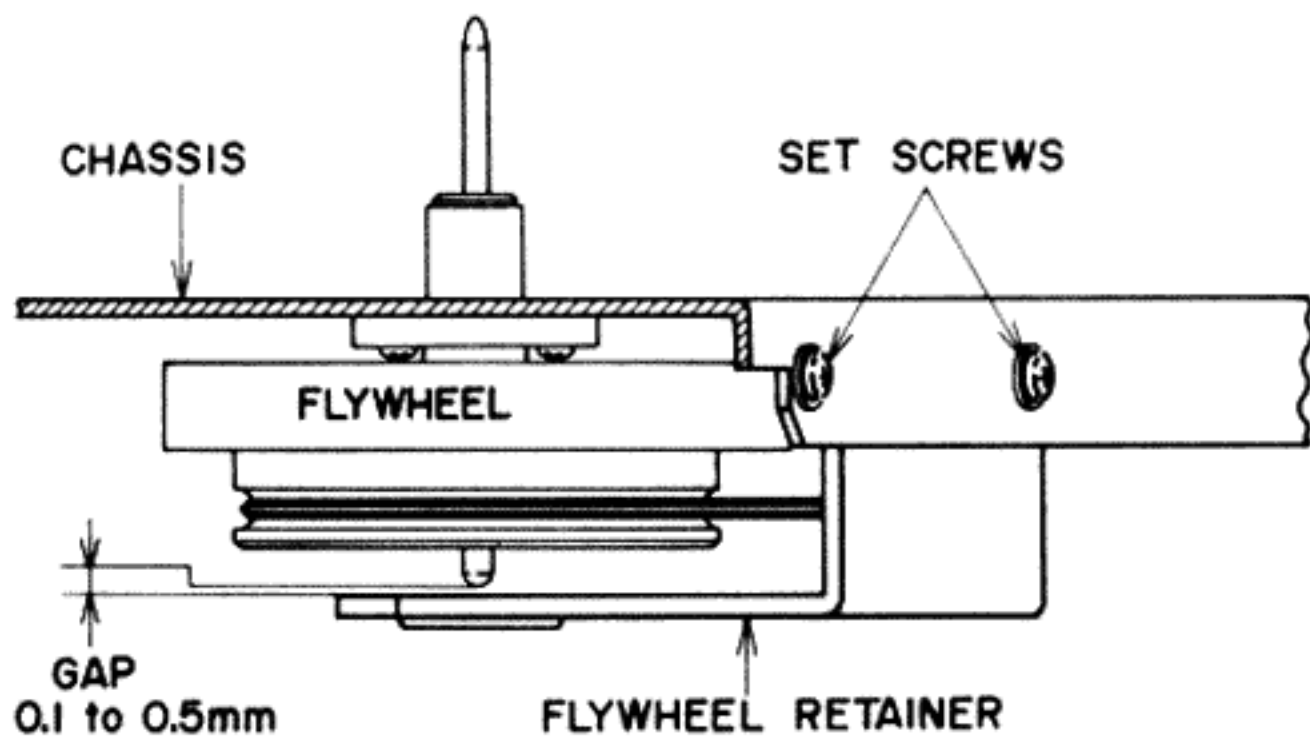

Fig. 9

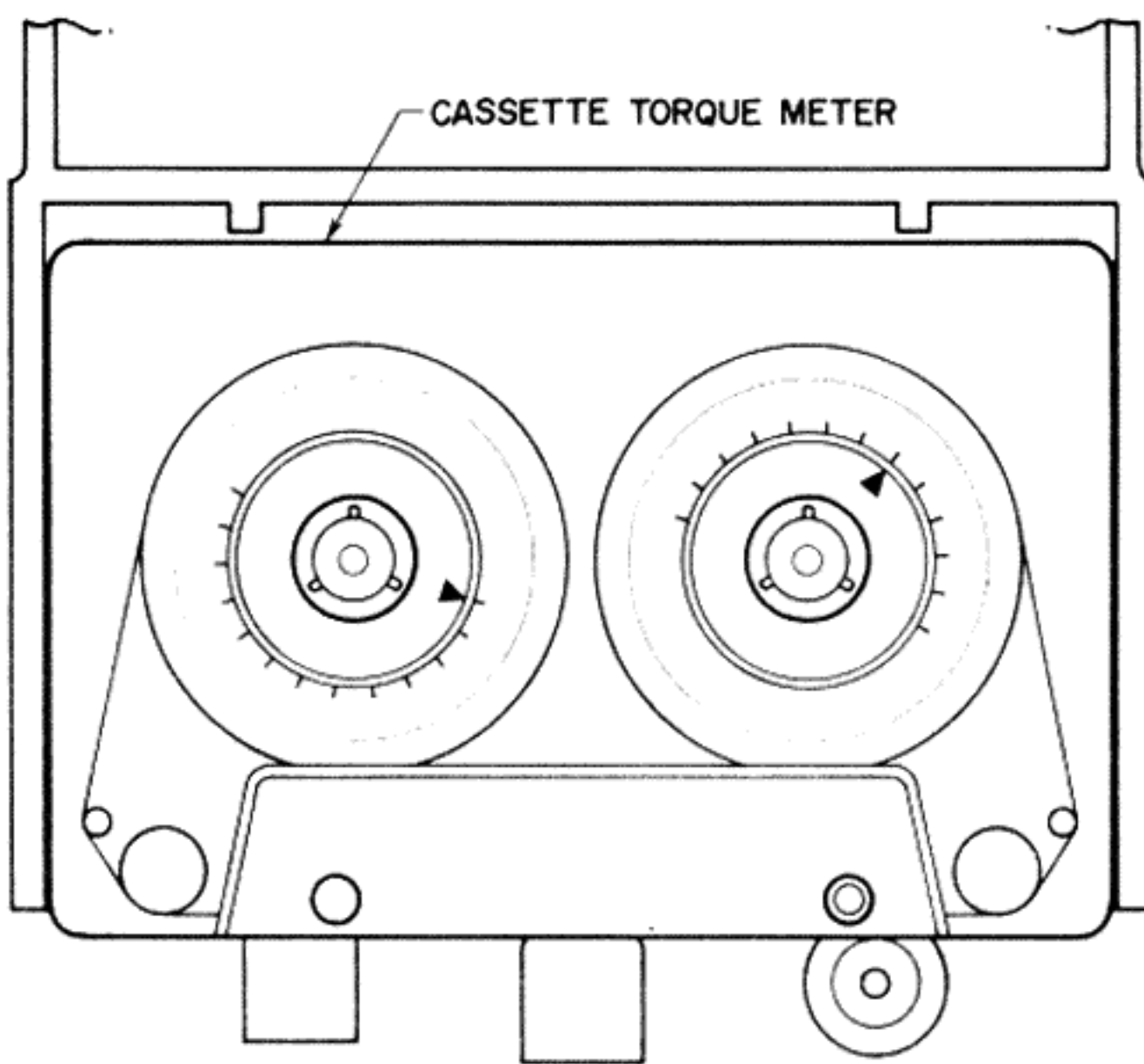

Fig. 10

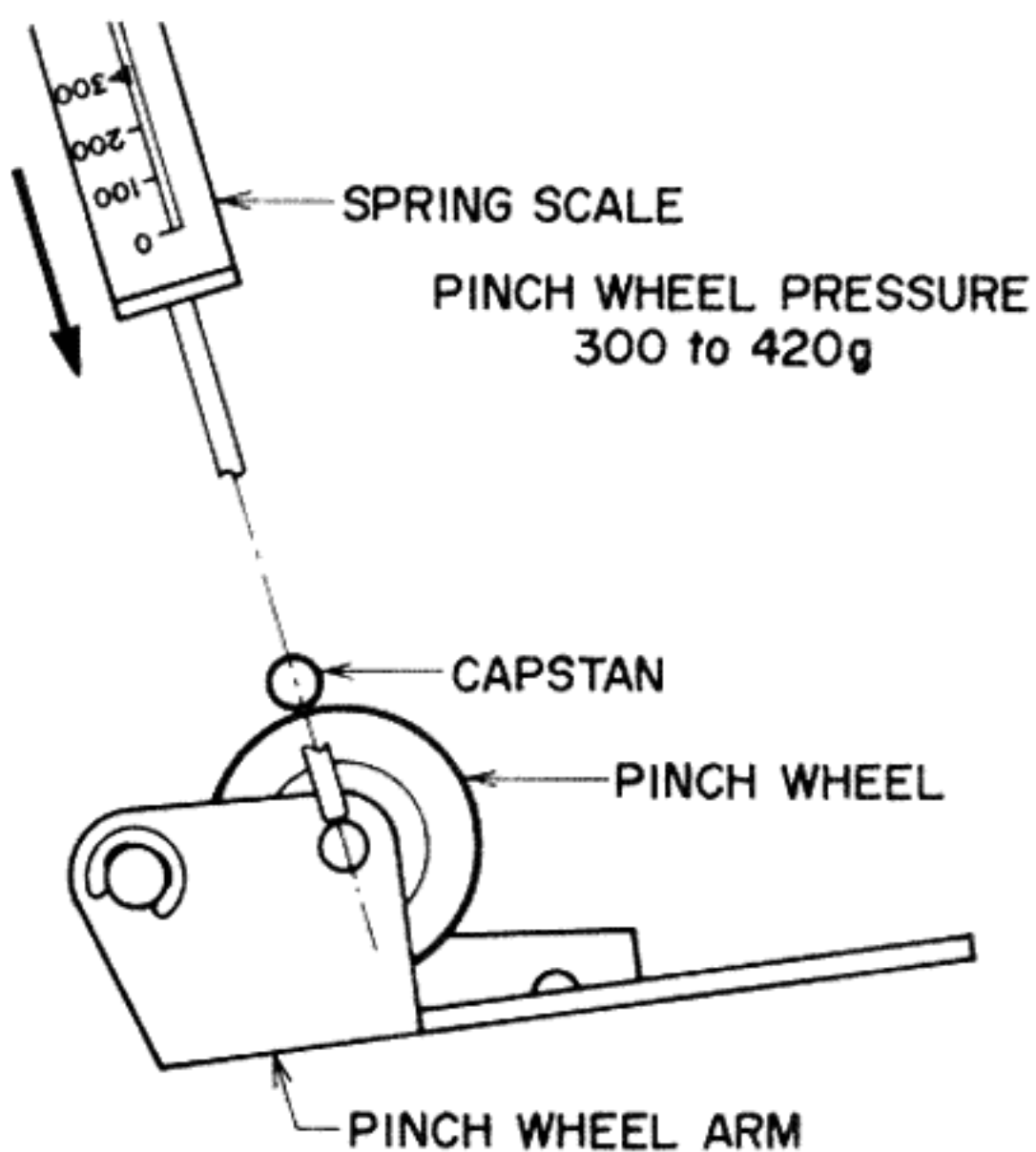

Fig. 11

### 1. FLYWHEEL LOOSE PLAY ADJUSTMENT

Loosen set screw and move the flywheel retainer inward and outward to adjust GAP between flywheel and retainer, then tighten set screw.

### 2. TAKE-UP TORQUE AT VARIOUS MODES AND TORQUE MEASURING METHOD

As shown in Fig. 10, set a cassette torque meter on cassette base, and take a reading of the indication at each respective mode.

PLAYBACK MODE	40 to 75g-cm
F.FWD MODE	60 to 120g-cm
RWD MODE	60 to 120g-cm

NOTE: Take the torque meter indication value +10g-cm as recorder take-up torque.

### 3. PINCH WHEEL PRESSURE MEASURING METHOD

As shown in Fig. 11, at playback mode, press the pinch wheel arm toward shaft with a spring scale, and when the pinch wheel separates from the capstan, read the spring scale indication.



## V. HEAD ADJUSTMENT

---

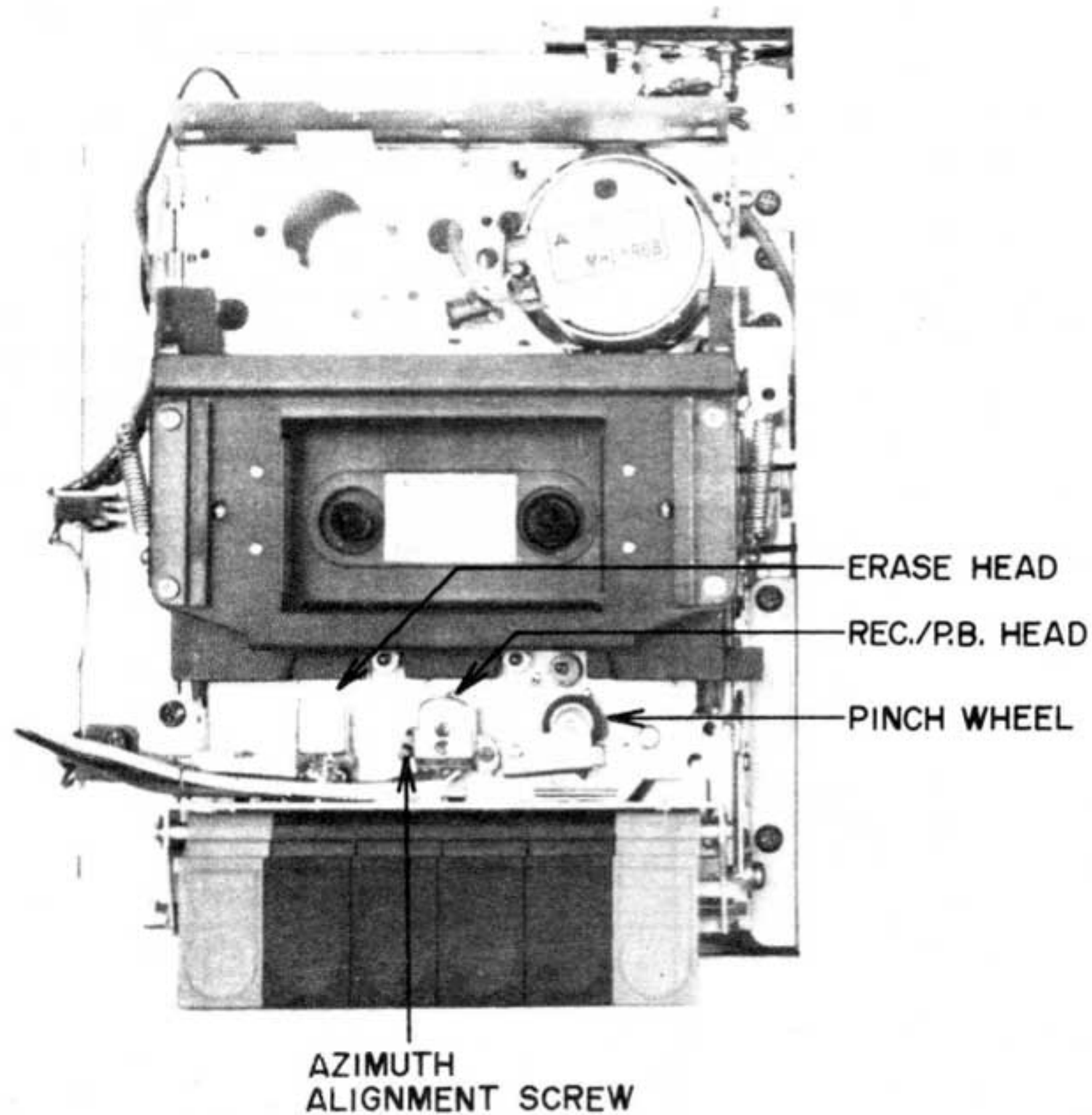

Fig. 12

### RECORDING/PLAYBACK HEAD AZIMUTH ALIGNMENT ADJUSTMENT (See Fig. 12)

- 1) Connect a High Sensitivity V.T.V.M. to the line outputs.
- 2) Playback a 10 kHz pre-recorded test tape.
- 3) Turn Azimuth Alignment Screw to left and right and adjust to obtain maximum left/right channel V.T.V.M. indication.
- 4) Always demagnetize heads following head adjustments.

# VI. AMPLIFIER ADJUSTMENTS

## I. PRE AMPLIFIER BLOCK DIAGRAM

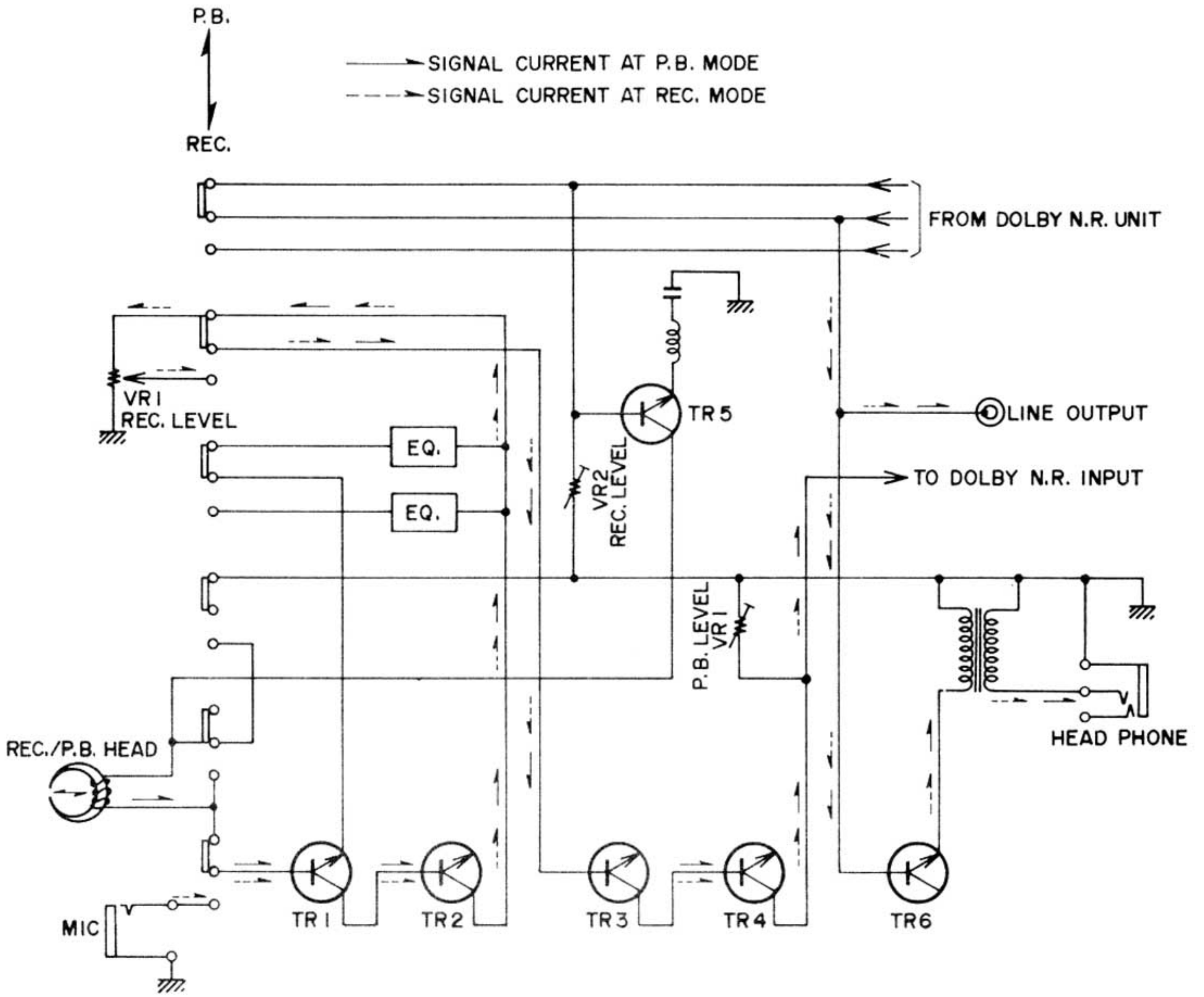

Fig. 13

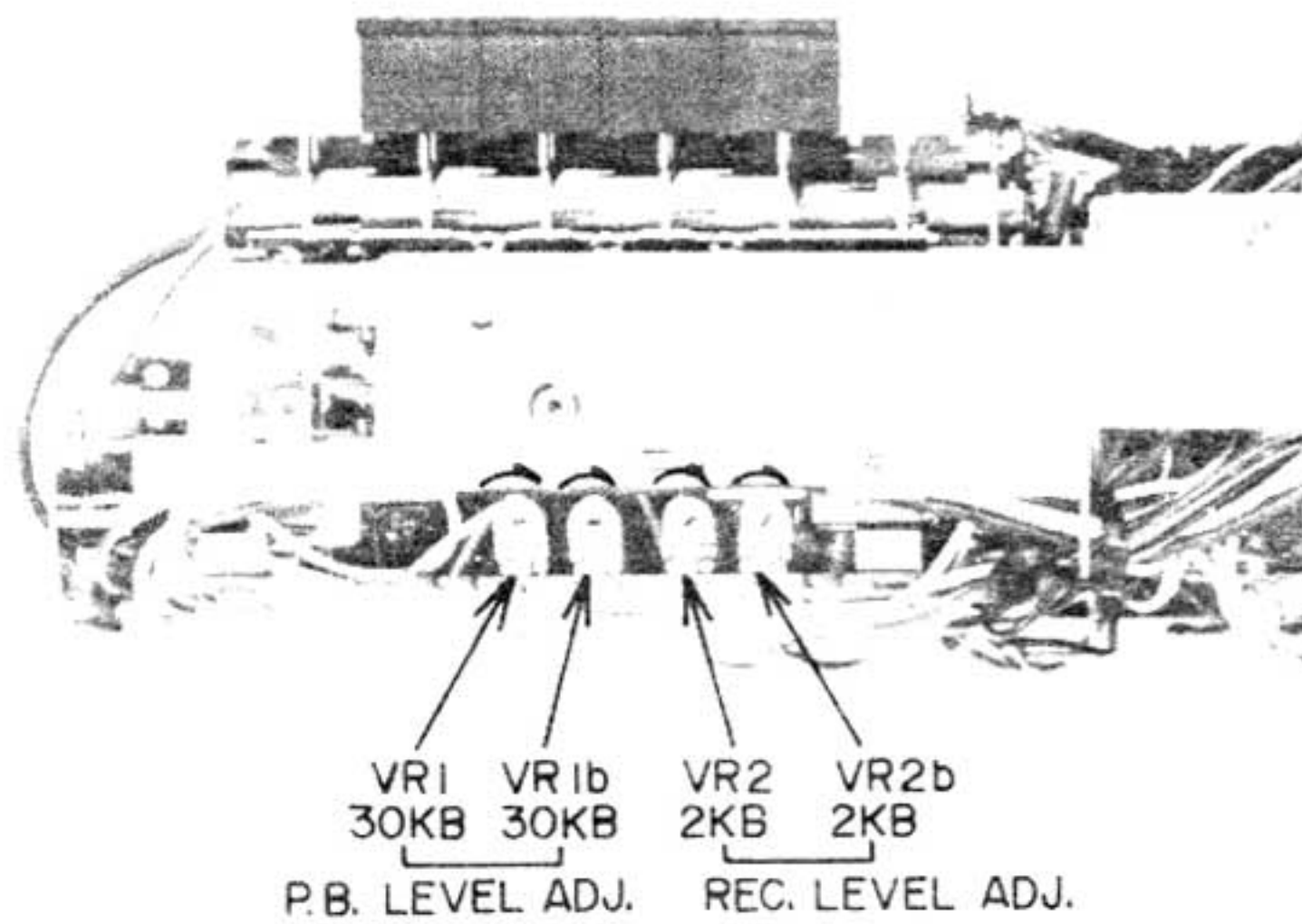

Fig. 14

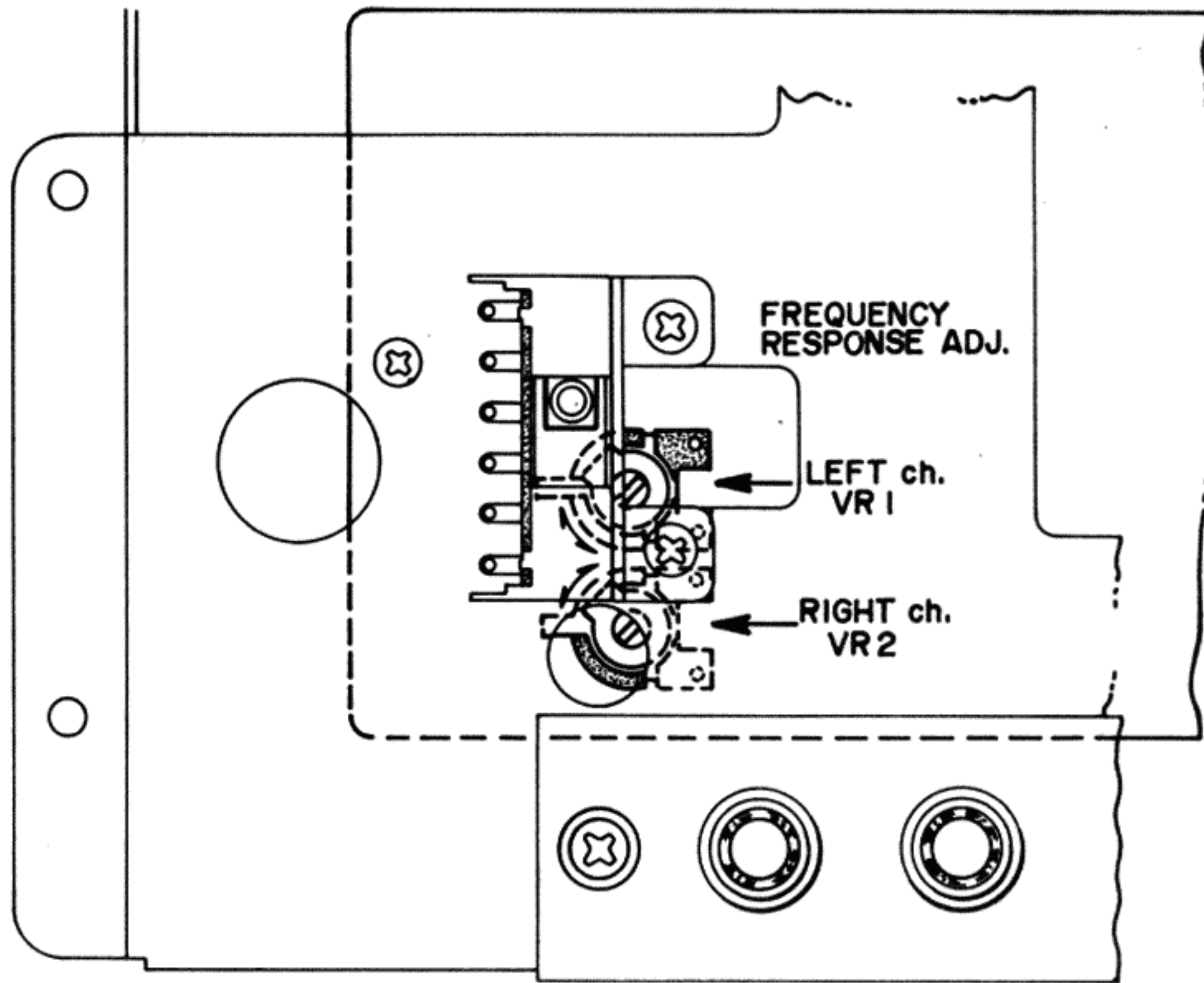

Fig. 15

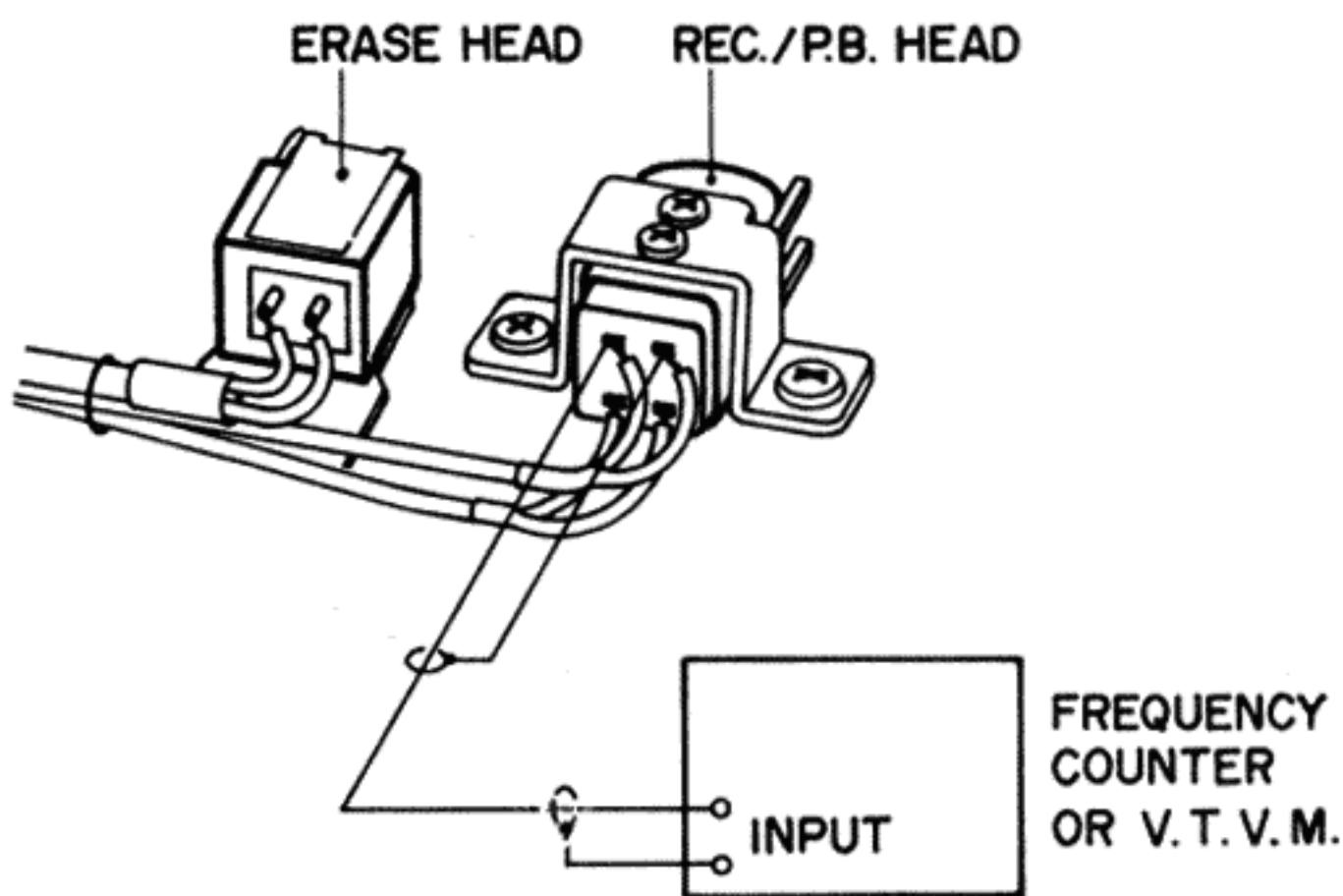

Fig. 16

## 2. PLAYBACK LEVEL ADJUSTMENT

(See Fig. 14)

- 1) Connect a High Sensitivity V.T.V.M. to the line outputs.
- 2) Turn Volume Controls to maximum. (Model CS-30 only)
- 3) Playback a 333 Hz pre-recorded cassette test tape and adjust Semi-fixed Resistors VR1 30 k $\Omega$  (left ch.), VR1b 30 k $\Omega$  (right ch.) of Pre-amp. P.C. Board to obtain a V.T.V.M. indication of 0 dB (0.775V).

## 3. RECORDING LEVEL ADJUSTMENT

(See Fig. 14)

- 1) Set Tape Selector to LOW NOISE and load a Low Noise blank cassette tape.
- 2) Set REC Level Controls or Volume Controls to maximum.
- 3) Set recorder to recording mode, and supply a 1,000 Hz signal to the line inputs from an Audio Frequency Oscillator through an Attenuator.
- 4) Adjust Attenuator to obtain a V.T.V.M. indication of 0 dB (0.775V).
- 5) Under these conditions, record for a few seconds and then playback this recorded tape and check the V.T.V.M. indications.
- 6) In case the line output level is not 0 dB, adjust Semi-fixed Resistors VR2 2 k $\Omega$  (left ch.) and VR2b 2 k $\Omega$  (right ch.) of Pre-amp. P.C. Board to obtain a 0 dB line output level and repeat Item 5) above.



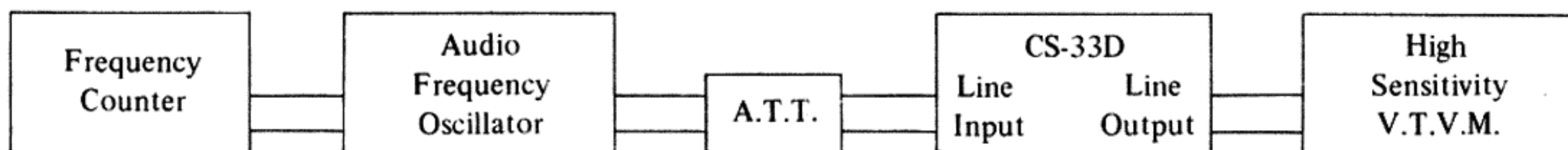

Fig. 17

#### 4. FREQUENCY RESPONSE ADJUSTMENT (See Fig. 15)

- 1) Playback the 1,000 Hz and 10,000 Hz signals recorded in Frequency Response measuring method procedure and adjust Semi-fixed Resistors VR1 300 k $\Omega$  (left ch.) and VR2 300 k $\Omega$  (right ch.) of OSC. Power Supply P.C. Board to obtain a flat output level at these 2 frequencies.
- 2) Re-check recording level following Frequency Response Adjustment.

NOTE: Electric shock will cause the heads to become magnetized, increasing distortion. Consequently, it is important that the heads be demagnetized with a large type demagnetizer after all adjustments have been completed.

#### 5. RECORDING BIAS FREQUENCY MEASUREMENT (See Fig. 16)

Set recorder to Rec. mode. Connect a frequency counter between the coil terminals of the Rec./P.B. Head as shown in Fig. 16 and read indication. Correct RECORDING BIAS FREQUENCY is  $63 \pm 5$  kHz.

#### 6. RECORDING BIAS VOLTAGE AND ERASE VOLTAGE MEASUREMENT

Set recorder to Rec. mode. As shown in Fig. 16, connect a V.T.V.M. between the coil terminals of each head and read indication.

ERASE VOLTAGE	Abt 36V A.C. (Low Noise)
	Abt 49V A.C. (Chrome)
RECORDING	
BIAS VOLTAGE	4 to 26V A.C.

#### 7. DOLBY AMPLIFIER ADJUSTMENT (This Adjustment is only for CS-33D)

- 1) **19 kHz Filter Adjustment**
  - a) Connect the various measuring instruments as shown in Fig. 17.
  - b) Using the Frequency Counter, set the oscillation frequency of the Audio Frequency Oscillator to exactly 19 kHz and supply this signal to the line input.
  - c) Set REC Level Controls VR1 50 k $\Omega$  (left ch.) VR2 50 k $\Omega$  (right ch.) to "10" position (maximum).
  - d) Set recorder to recording mode, and adjust the dust core of 19 kHz Filter Coil L2 (left ch.) L2b (right ch.) of the Dolby Amp. P.C. Board to obtain minimum line output level.
- 2) **Recording Circuit Adjustment**
  - a) Connect the various measuring instruments as shown in Fig. 17.
  - b) Turn Dolby N.R. Amp. P.C. Board Dolby Amp. Gain Adjustment Semi-fixed Resistors VR2 500 $\Omega$  (left ch.) VR2b 500 $\Omega$  (right ch.) and FET Gate Bias Adjustment Semi-fixed Resistors VR1 5 k $\Omega$  (left ch.) VR1b 5 k $\Omega$  (right ch.) as far as they will go in the direction of the arrows shown in Fig. 18.
  - c) Turn Dolby Switch SW6 to OFF position and as shown in Fig. 19, ground Test Point "TP1" (FET GATE).
  - d) Set the oscillation frequency of the Audio Frequency Oscillator to 5 kHz and supply this signal to the line input.
  - e) Set recorder to recording mode, and adjust the Attenuator to obtain a 2 dB line output level.
  - f) At this condition, further adjust the Attenuator so that the line output level at Point (A) shown in Fig. 18 is  $-28.5$  dB. At this time, confirm that the level at Point (B) shown in Fig. 18 is  $-28.5 + 0.5$  dB.
  - g) Turn Dolby Switch SW6 to ON position. At this time, adjust Dolby Amp. Gain Adjustment Semi-fixed Resistors VR2 500 $\Omega$  (left ch.) VR3b 500 $\Omega$  (right ch.) until the voltage at Point (B) shown in Fig. 18 is increased by 10 dB.
  - h) Disconnect ground from Test Point "TP" (FET Gate). At this time, adjust FET Gate Bias Adjustment Semi-fixed Resistors VR1 5 k $\Omega$  (left ch.) VR1b 5 k $\Omega$  (right ch.) so that the voltage at Point (B) shown in Fig. 18 is reduced by 2 dB.



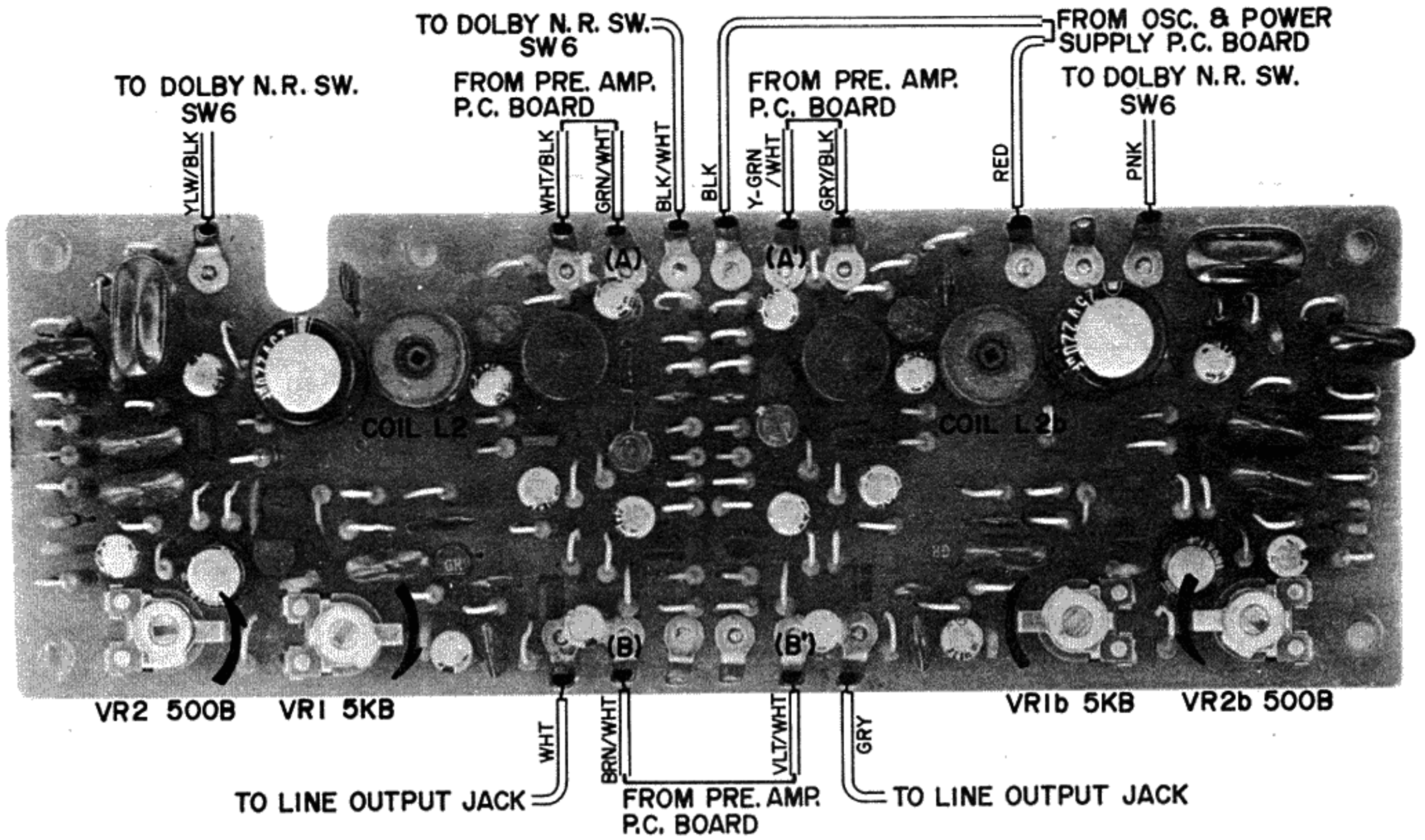

Fig. 18 DOLBY AMP. P.C. BOARD CG-5202 (Face Side)

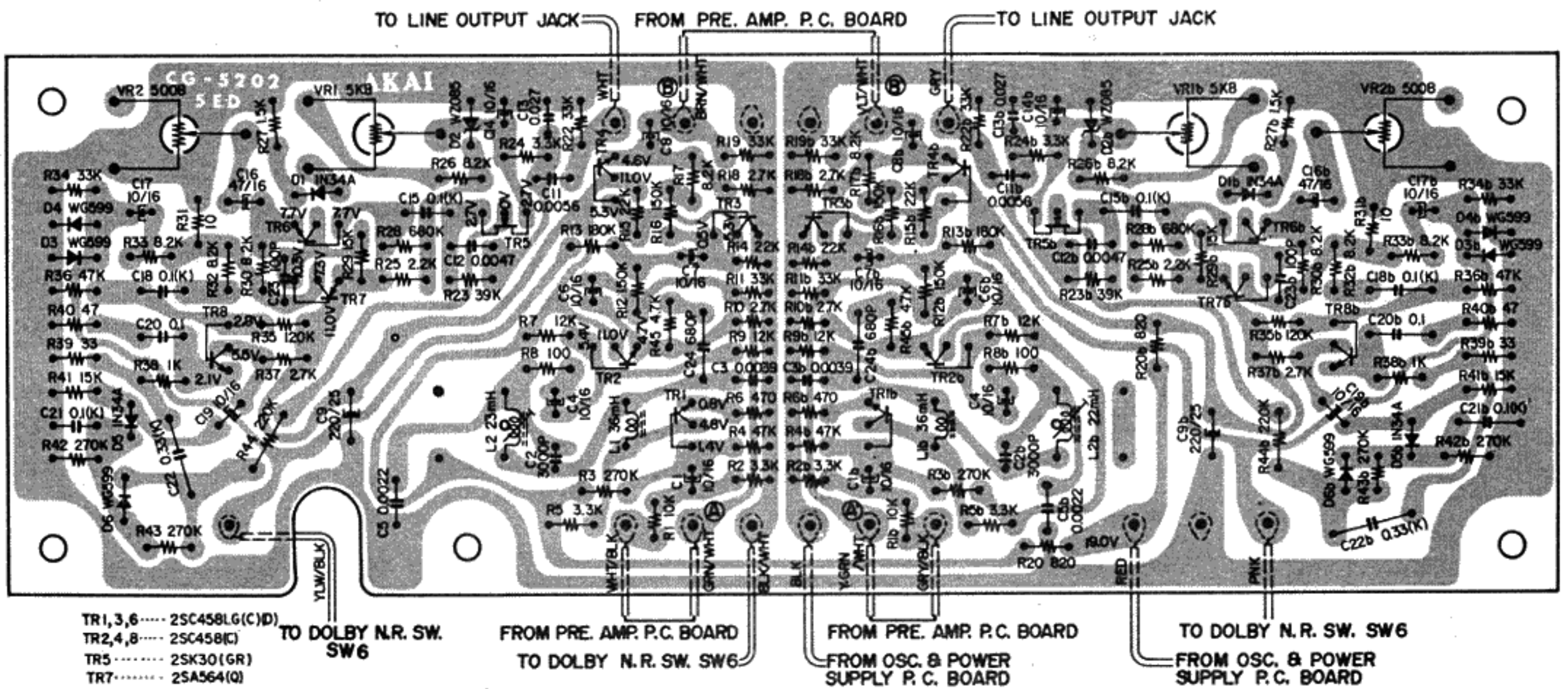

Fig. 19 DOLBY AMP. P.C. BOARD CG-5202 (Reverse Side)

## VII. D.C. RESISTANCE OF EACH COIL

---

Values shown in chart below are average D.C. resistance values.

Parts	Type	D.C. Resistance
RECORDING/PLAYBACK HEAD	P4-303	110 $\Omega$
ERASE HEAD	AE-134	6 $\Omega$
HEADPHONE OUTPUT TRANSFORMER	N16-535S	565 $\Omega$ $\pm$ 15% PRIMARY 0.95 $\Omega$ $\pm$ 15% SECONDARY
OSCILLATION COIL	OT-903	0.04 $\Omega$ between 1 and 3 0.14 $\Omega$ between 4 and 6 0.65 $\Omega$ between 7 and 9

Chart 1



** AKAI ELECTRIC CO., LTD.  
AKAI TRADING CO., LTD.**

(P.O. BOX 21, Tokyo International Airport, Japan)  
12-14, 2-chome, Higashi-Kojiya, Ohta-ku, Tokyo, Japan  
TELEPHONE: TOKYO (742) 5 1 1 1  
CABLE: HIFI AKAI TOKYO    TELEX: J26261

Printed No. 1480636    Printed in Japan