

SERVICE MANUAL

PARTS LIST

MODEL GX-635D

AKAI

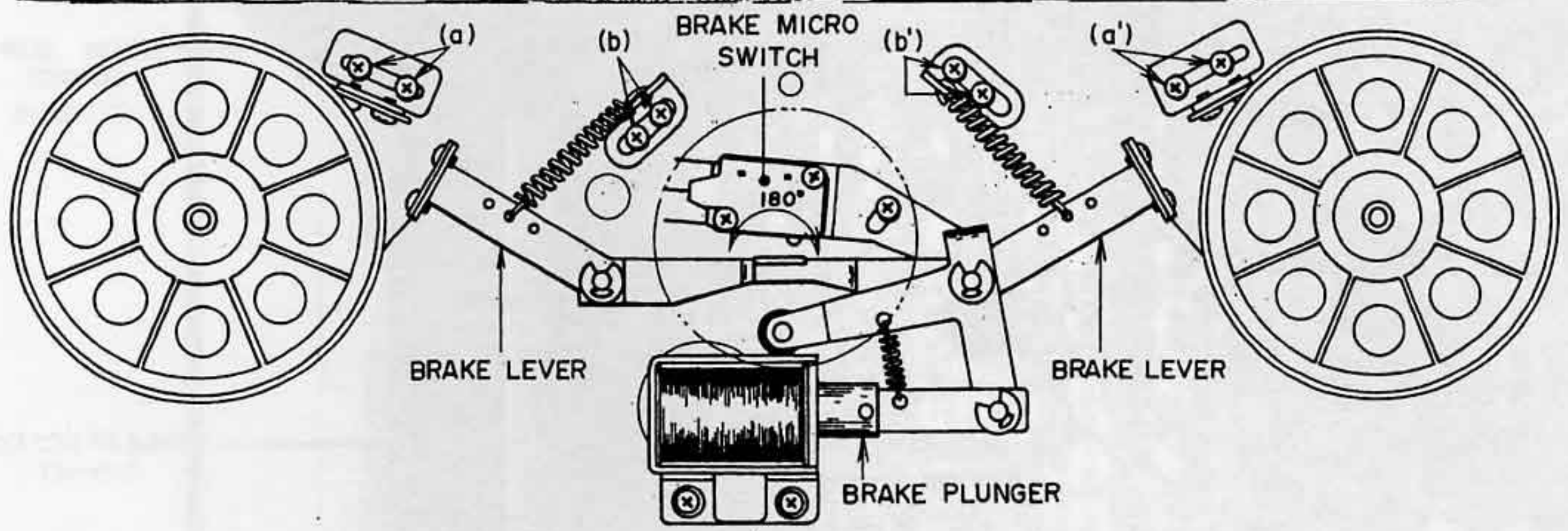

Fig. 11

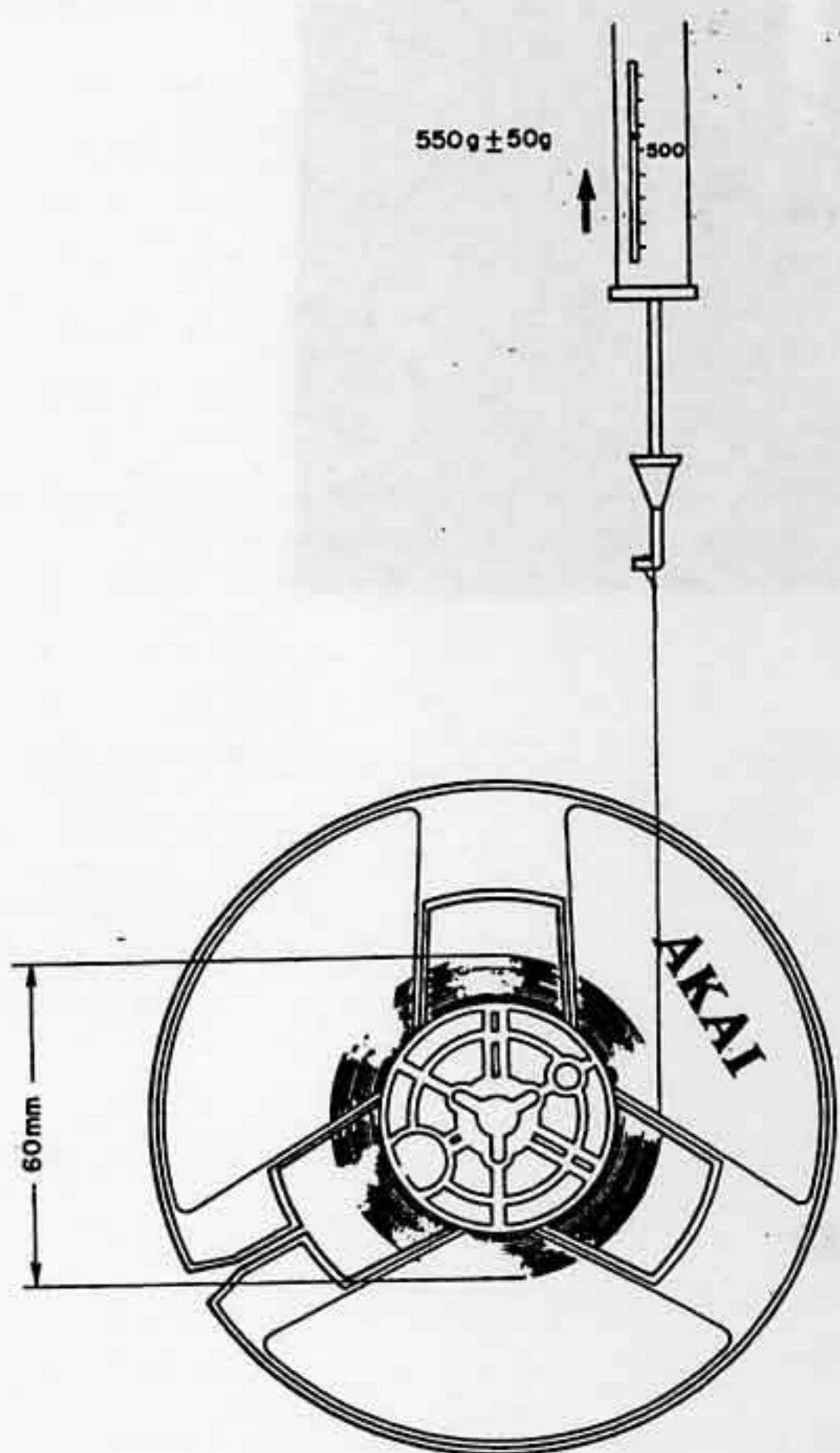

Fig. 12

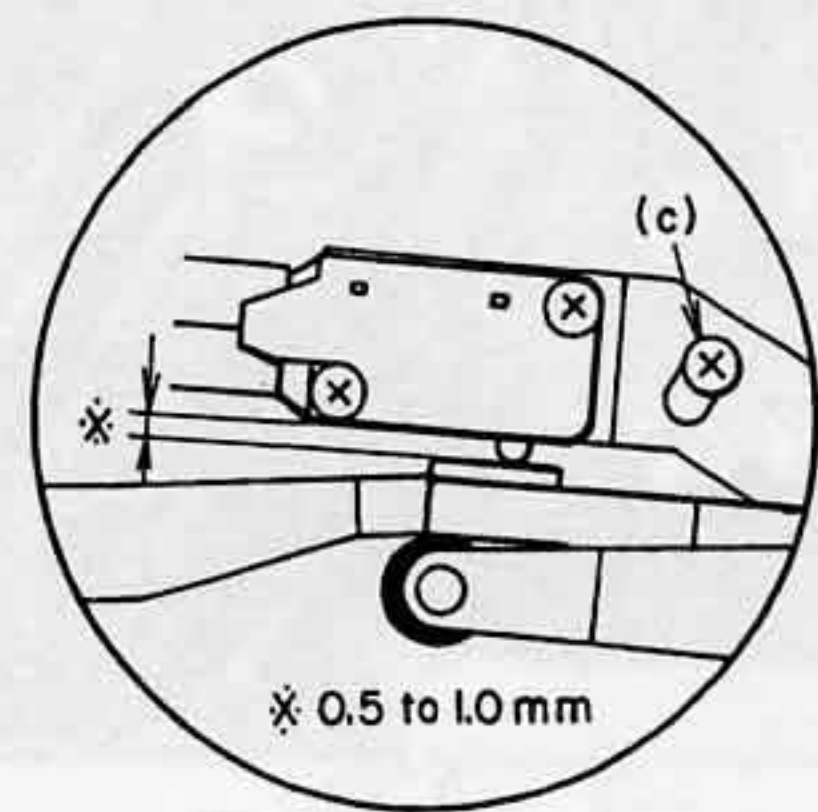

Fig. 13

6. BRAKE BAND POSITION ADJUSTMENT AND BRAKE TENSION ADJUSTMENT

(Refer to Figs. 11 to 13)

- 1) Adjust the brake lever to 180° position by loosening the screws (a) and (a').
- 2) Work the brake plunger to check that the brake band is not slanted.
- 3) Adjust the position of the part with screws (b) and (b') to obtain a brake tension of $550 \pm 50g$ on both brakes at stop mode.
(Use a 1000g spring gauge for a reel with 60 mm diameter of tape.)
In case the specified brake tension cannot be obtained, connect the springs to the other holes on the brake lever and adjust.
- 4) By working the brake plunger with a finger, adjust the position of the microswitch screw (c) so that the gap between the brake lever and the microswitch body is 0.5 to 1.0 mm.

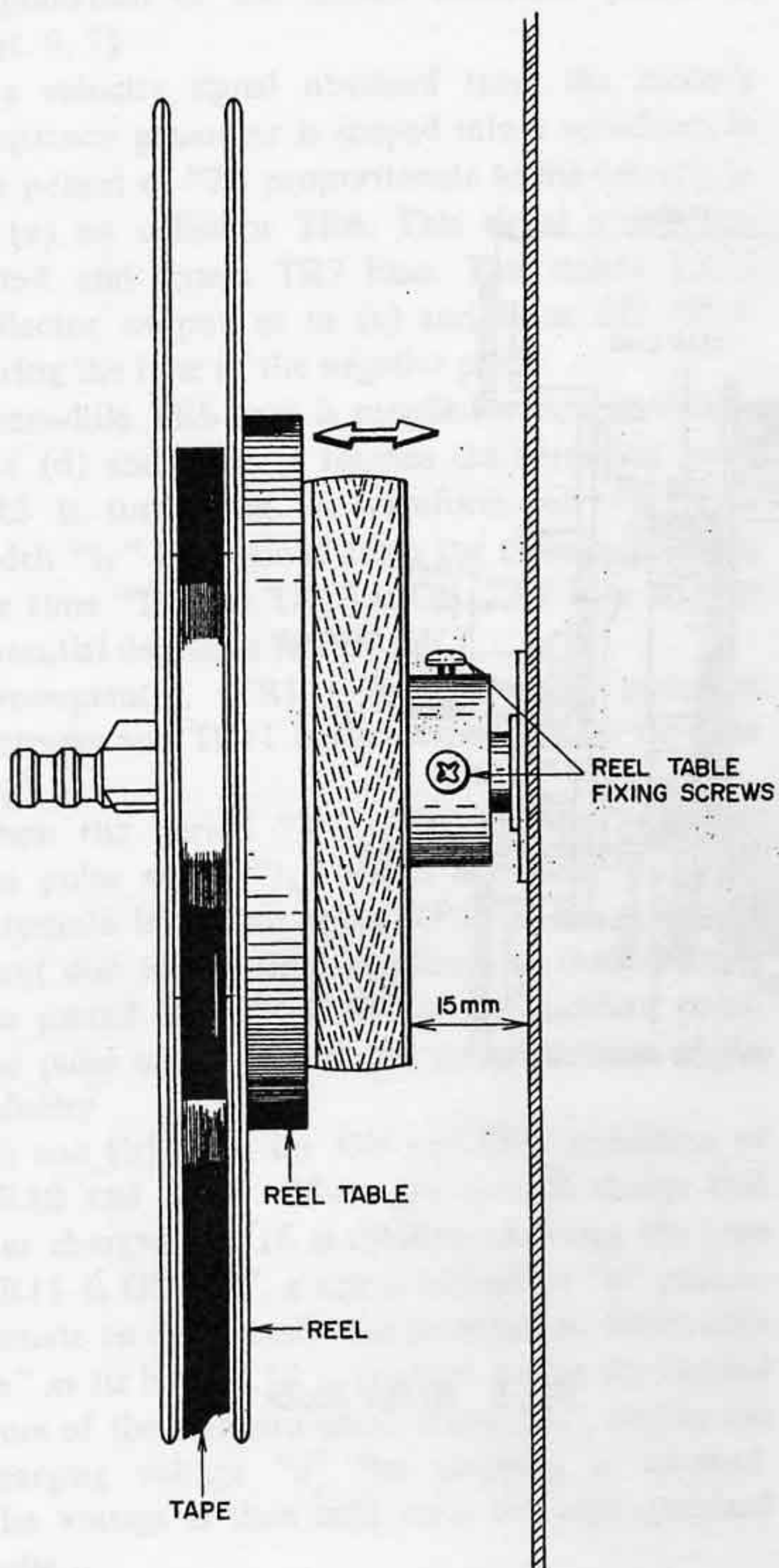

Fig. 9

4. REEL TABLE HEIGHT ADJUSTMENT (Refer to Fig. 9)

- 1) Temporarily screw in the fixing screws leaving a gap of 15 mm between the reel table and the chassis board.
- 2) Run the tape and adjust the height of the reel table so that the tape is taken up in the center of the reel. Tighten fixing screws.
Adjust the height of the right reel table at fast forward, of the left reel table at rewind.

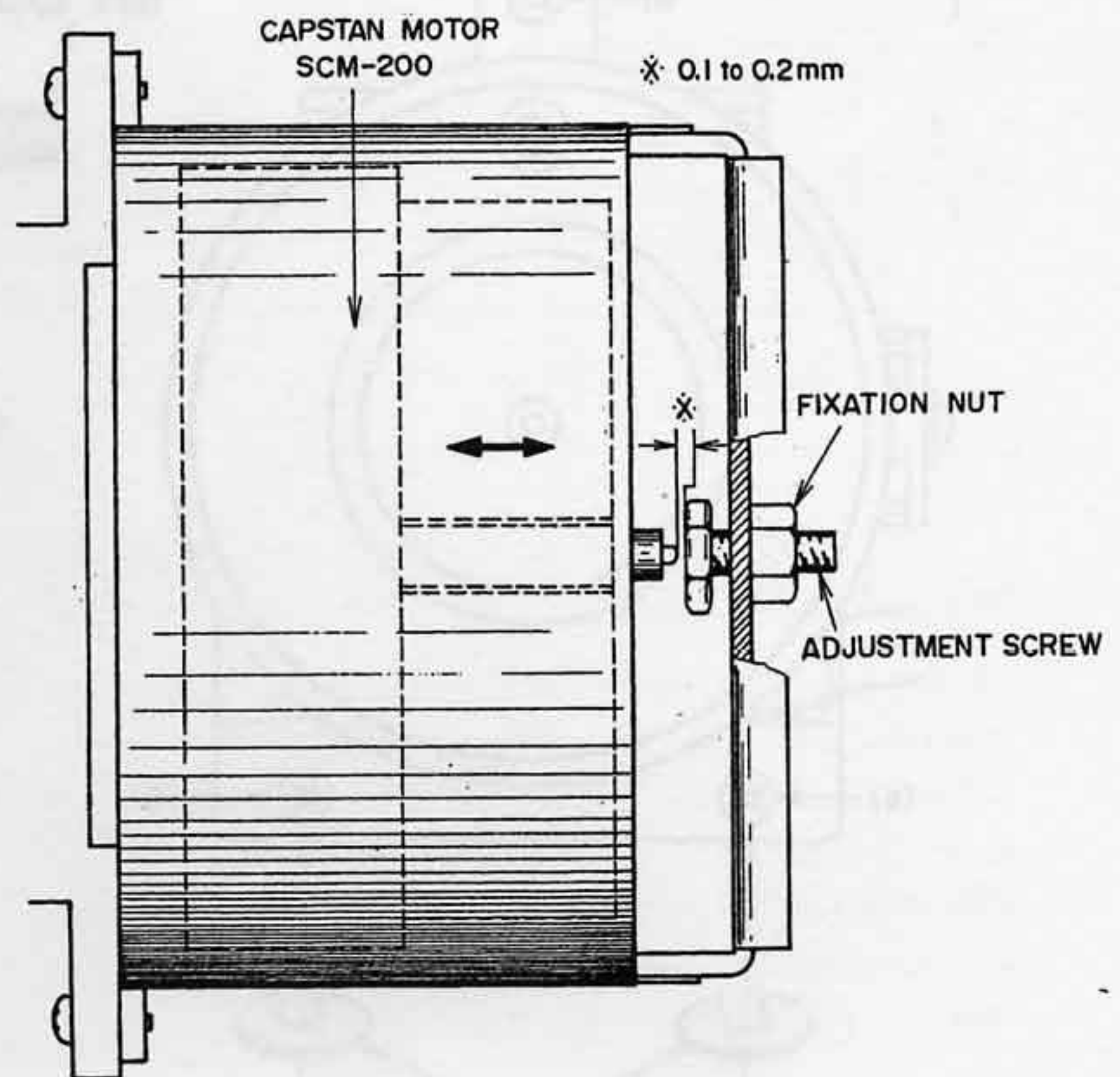

Fig. 10

5. CAPSTAN SHAFT LOOSE PLAY ADJUSTMENT (Refer to Fig. 10)

Adjust by turning Adjustment Screw to obtain a 0.1 to 0.2 mm degree of loose play when the capstan shaft is moved as indicated by the arrow mark. Tighten fixation nut to maintain optimum adjusted condition.

VI. MECHANISM ADJUSTMENT

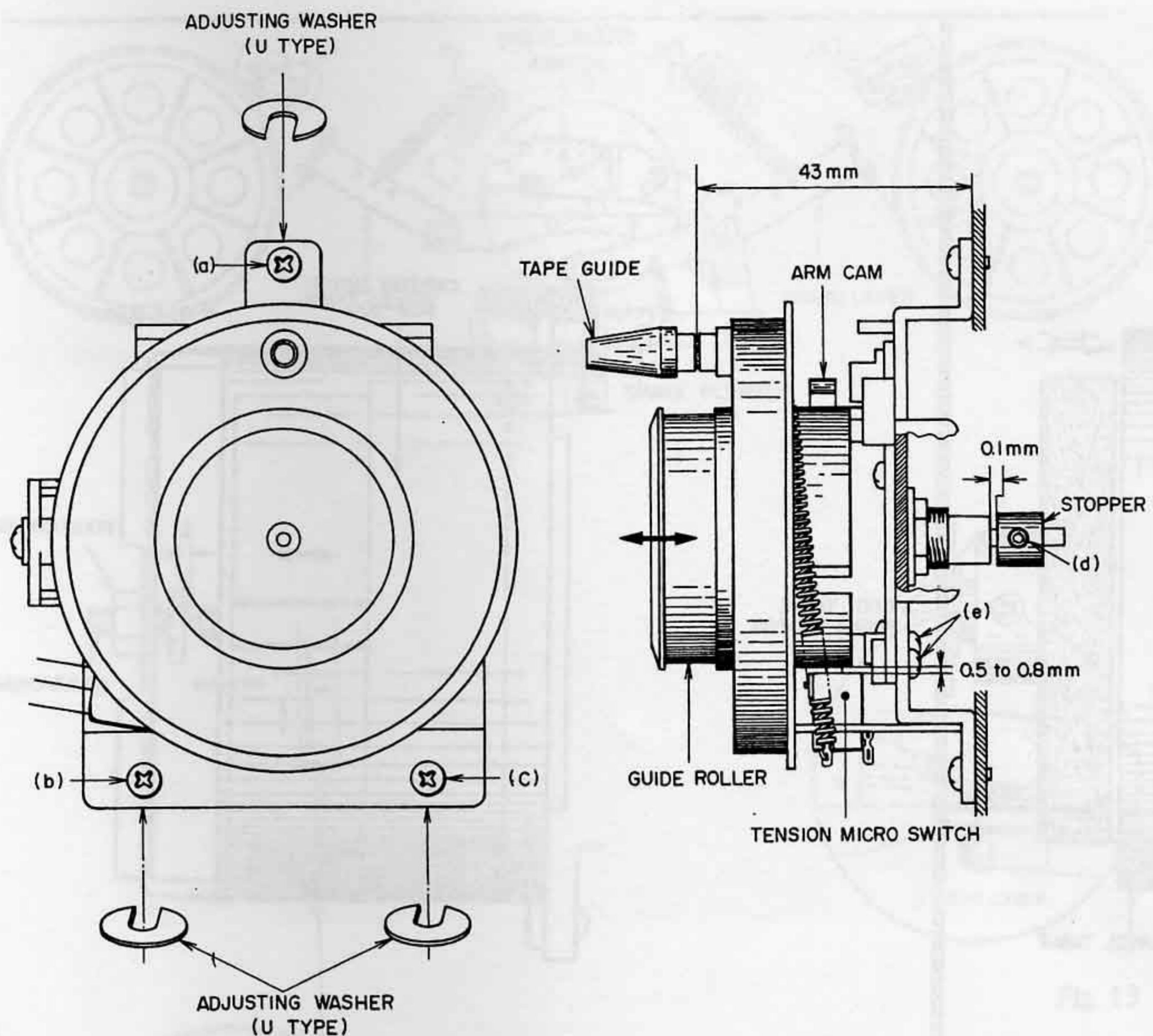

Fig. 8 Roller Block

1. GUIDE ROLLER LOOSE PLAY

ADJUSTMENT (Refer to Fig. 8)

Adjust the stopper (roller pulley on the right) screw (d) so that the loose play gap is approximately 0.1 mm when the guide roller is moved as indicated by arrow mark in Fig. 8.

2. TENSION MICRO SWITCH POSITION

ADJUSTMENT (Refer to Fig. 8)

Adjust the screws (e) so that the gap between the arm cam and the micro switch is approximately 0.5 to 0.8 mm. Check that the micro switch works and that the arm lock smoothly disengages.

3. ROLLER BLOCK HEIGHT

ADJUSTMENT (Refer to Fig. 8)

Use the U type adjusting washers for screws (a), (b), and (c) to adjust the roller block height: the distance between the tape guide center to the chassis board should be 43 mm.

NOTE: Steps 1 and 3 also apply to the right guide roller.

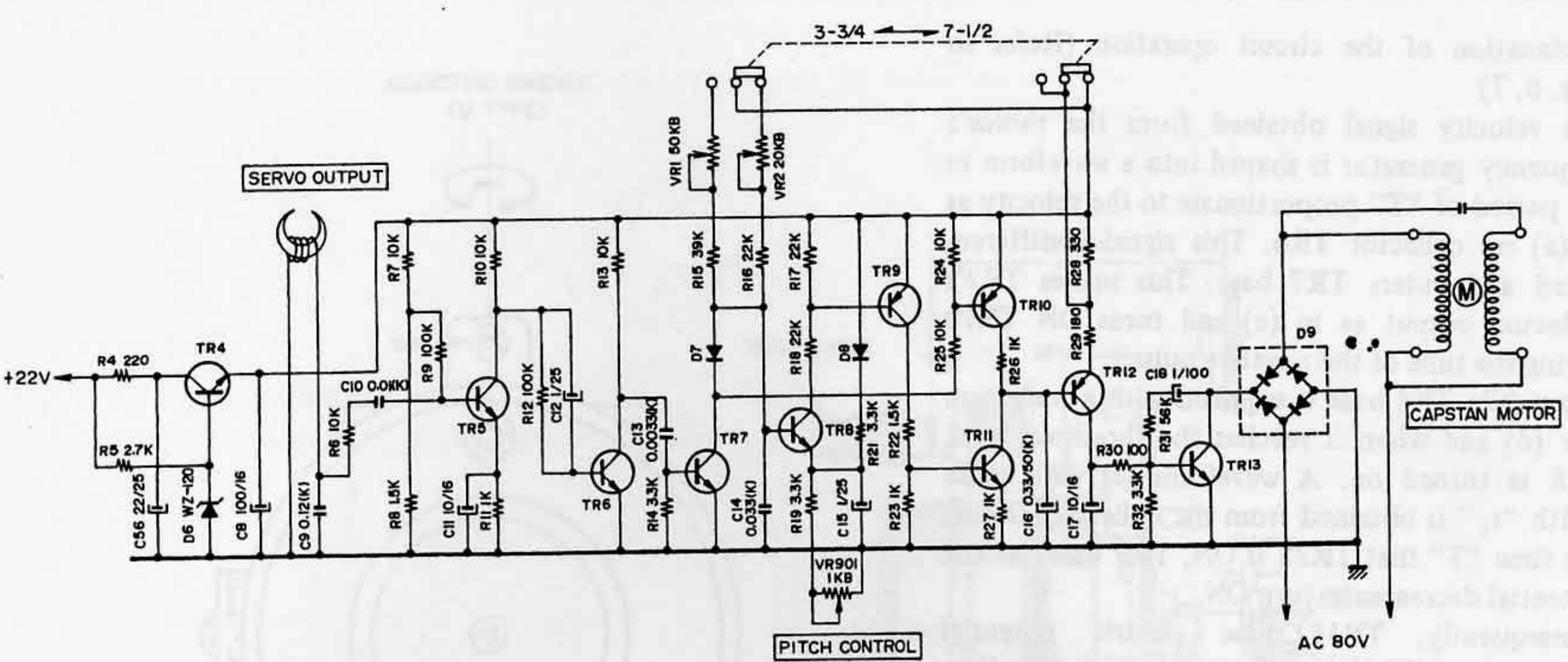

Fig. 6

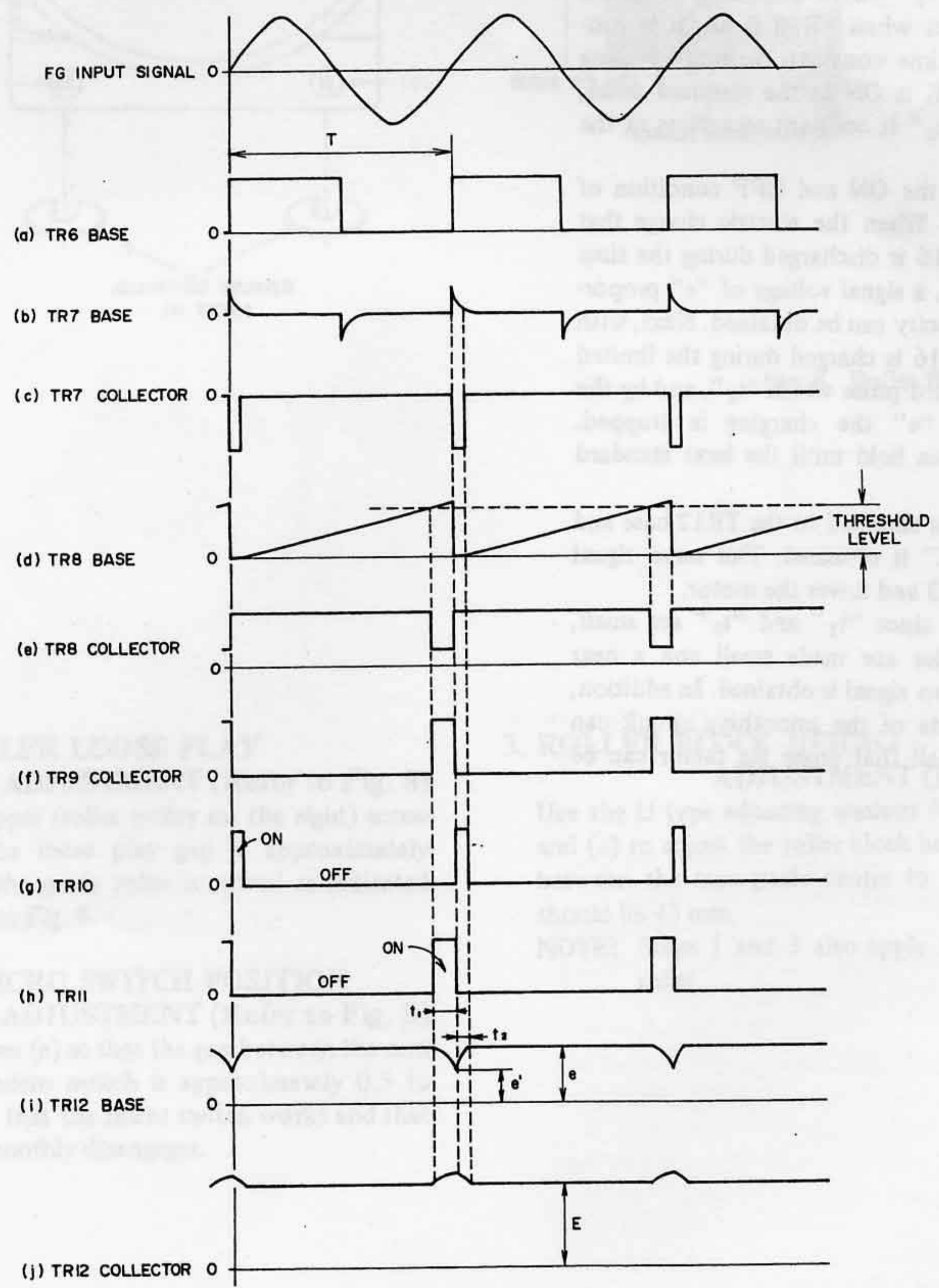
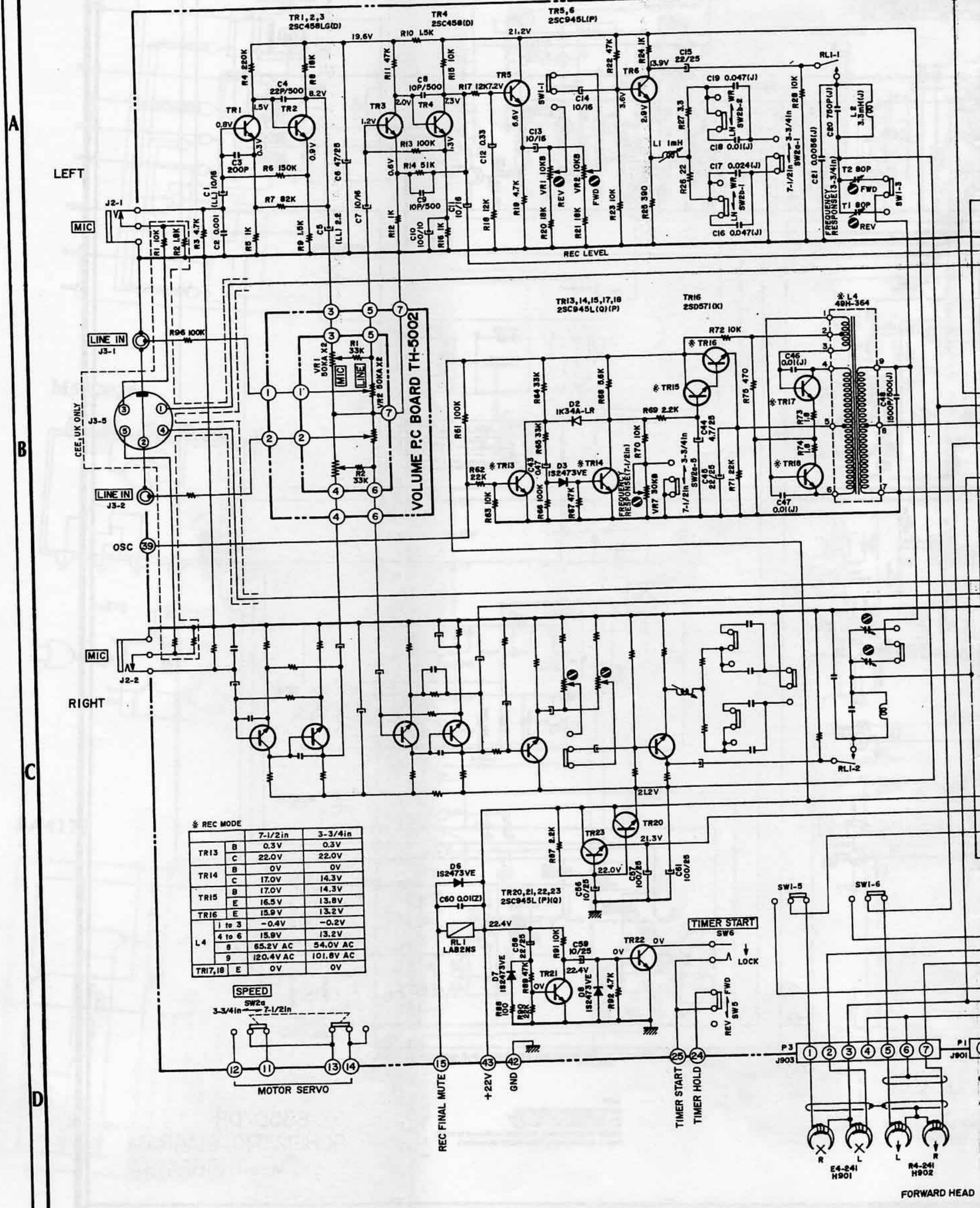
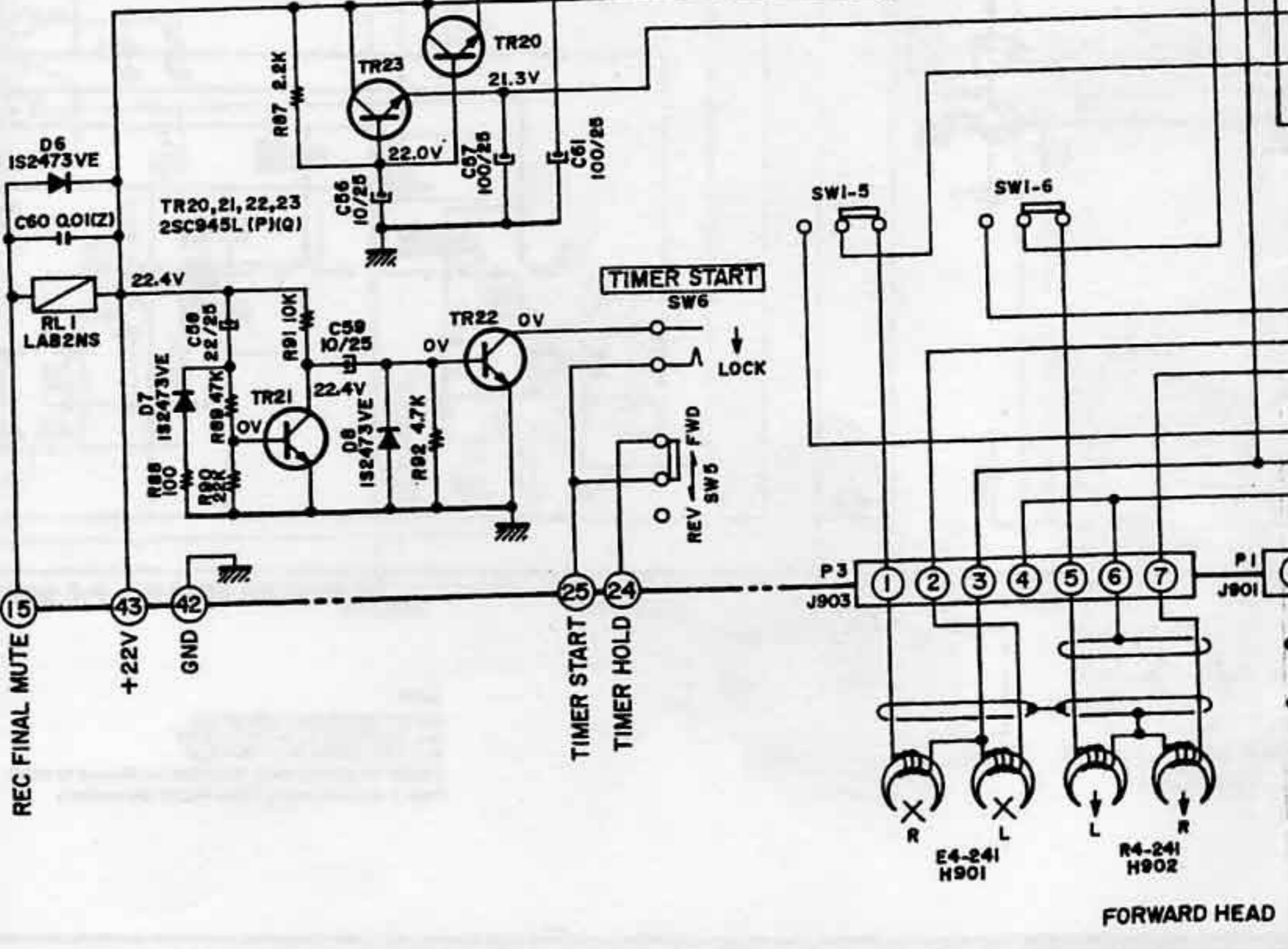
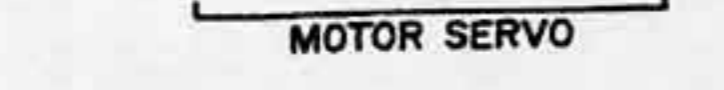
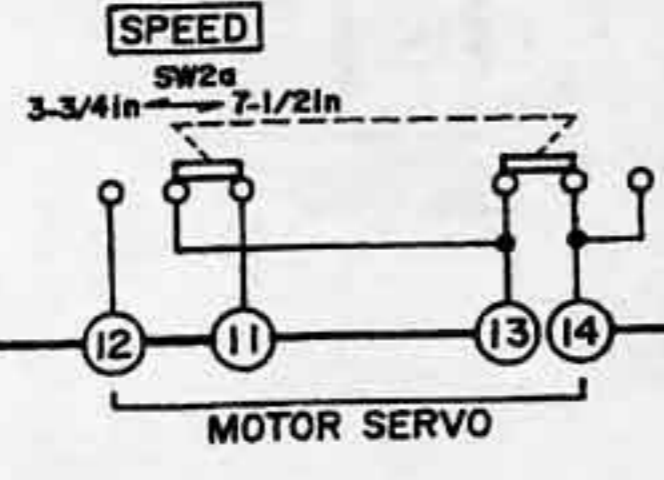

Fig. 7



* REC MODE

		7-1/2in	3-3/4in
TR13	B	0.3V	0.3V
	C	22.0V	22.0V
TR14	B	0V	0V
	C	17.0V	14.3V
TR15	B	17.0V	14.3V
	E	16.5V	13.8V
TR16	E	15.9V	13.2V
	I to 3	-0.4V	-0.2V
L4	4 to 6	15.9V	13.2V
	8	65.2V AC	54.0V AC
	9	120.4V AC	101.8V AC
TR17,18	E	0V	0V



LEFT

RIGHT

VOLUME PC BOARD TH-5002

A

B

C

D

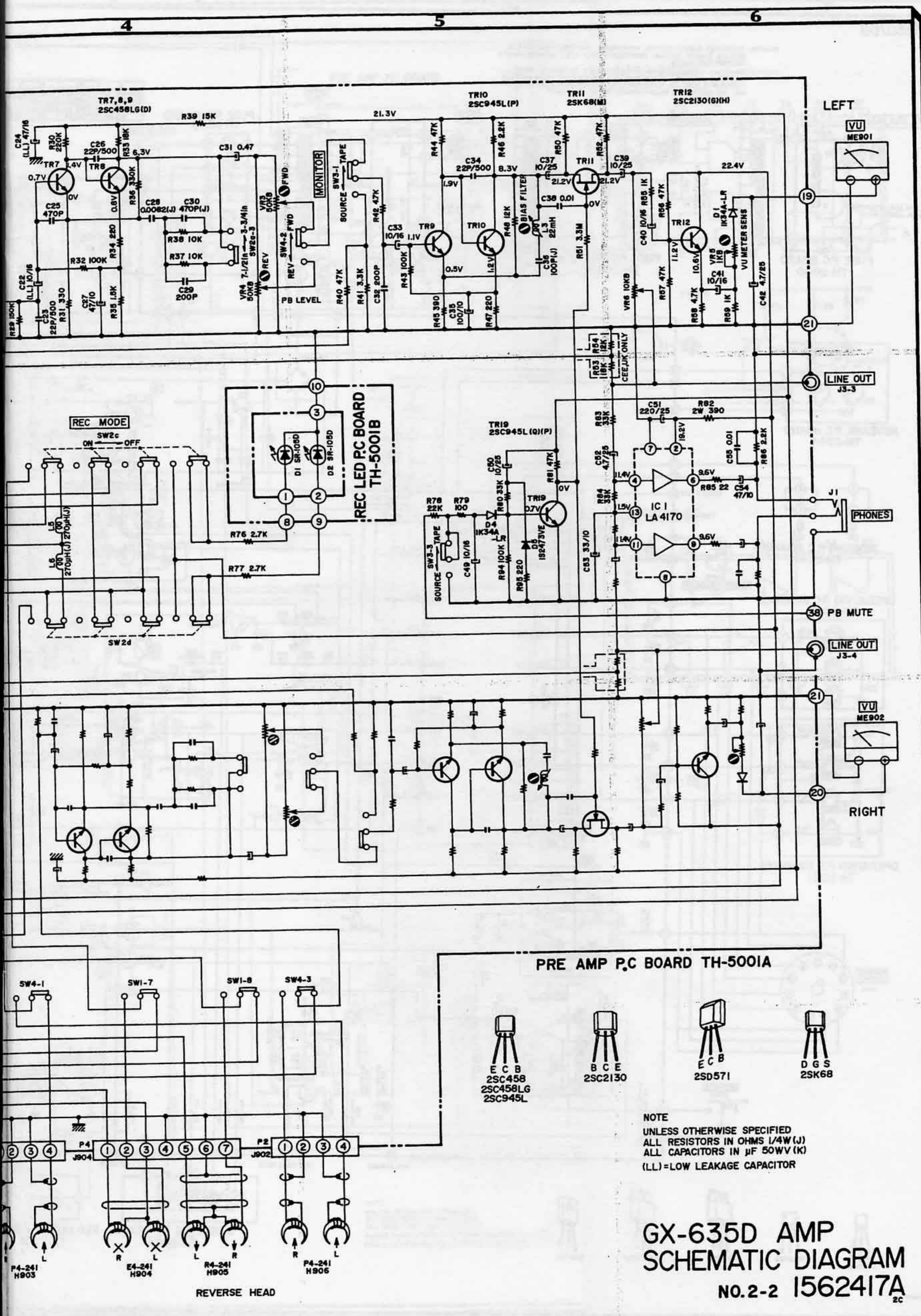

GX-635D/DB

WARNING: Δ INDICATES SAFETY CRITICAL COMPONENTS. FOR CONTINUED SAFETY, REPLACE SAFETY CRITICAL COMPONENTS ONLY WITH MANUFACTURER'S RECOMMENDED PARTS.
 AVERTISSEMENT: Δ IL INDIQUE LES COMPOSANTS CRITIQUES DE SURETE. POUR MAINTENIR LE DEGRE DE SECURITE DE L'APPAREIL NE REMPLACER LES COMPOSANTS DONT LE FONCTIONNEMENT EST CRITIQUE POUR LA SECURITE QUE PAR DES PIECES RECOMMANDEES PAR LE FABRICANT

S	F1	F2	F3
U/T (200V AREA)	E50V 1A	E50V 1.6A	E50V 0.8A
U/T (100V AREA)	E50V 2A	E50V 1.6A	E50V 0.8A
JPN, CSA, AAL	E50V 2A	E50V 1.6A	E50V 0.8A
CEE, UK	T500mA	T1A	T500mA

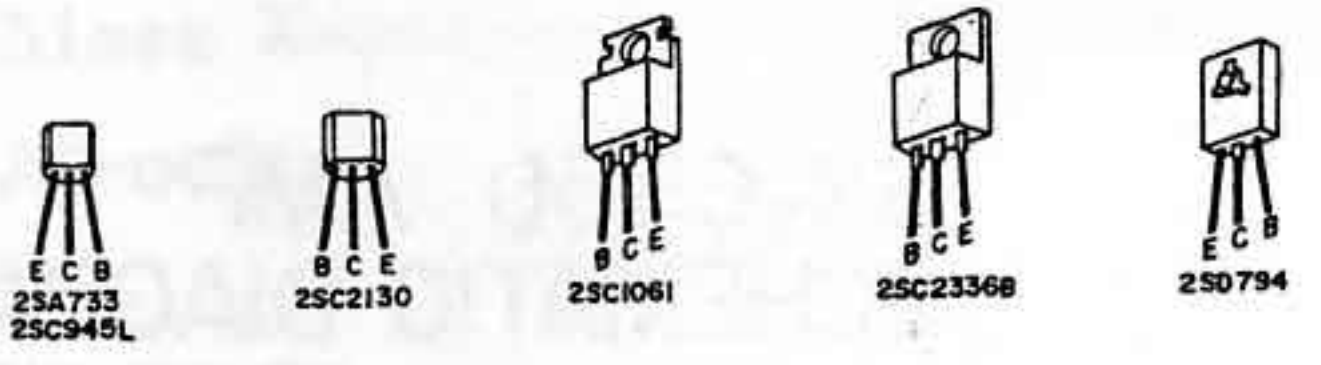
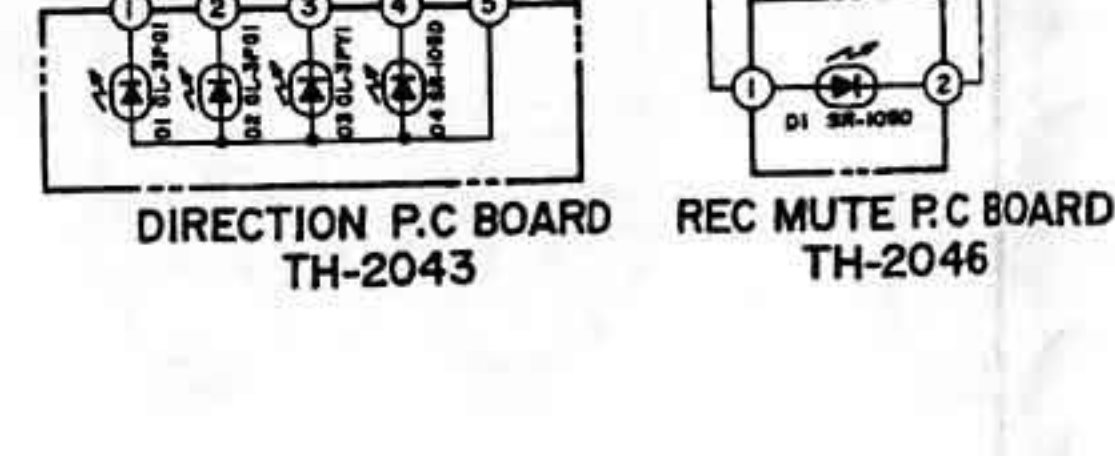
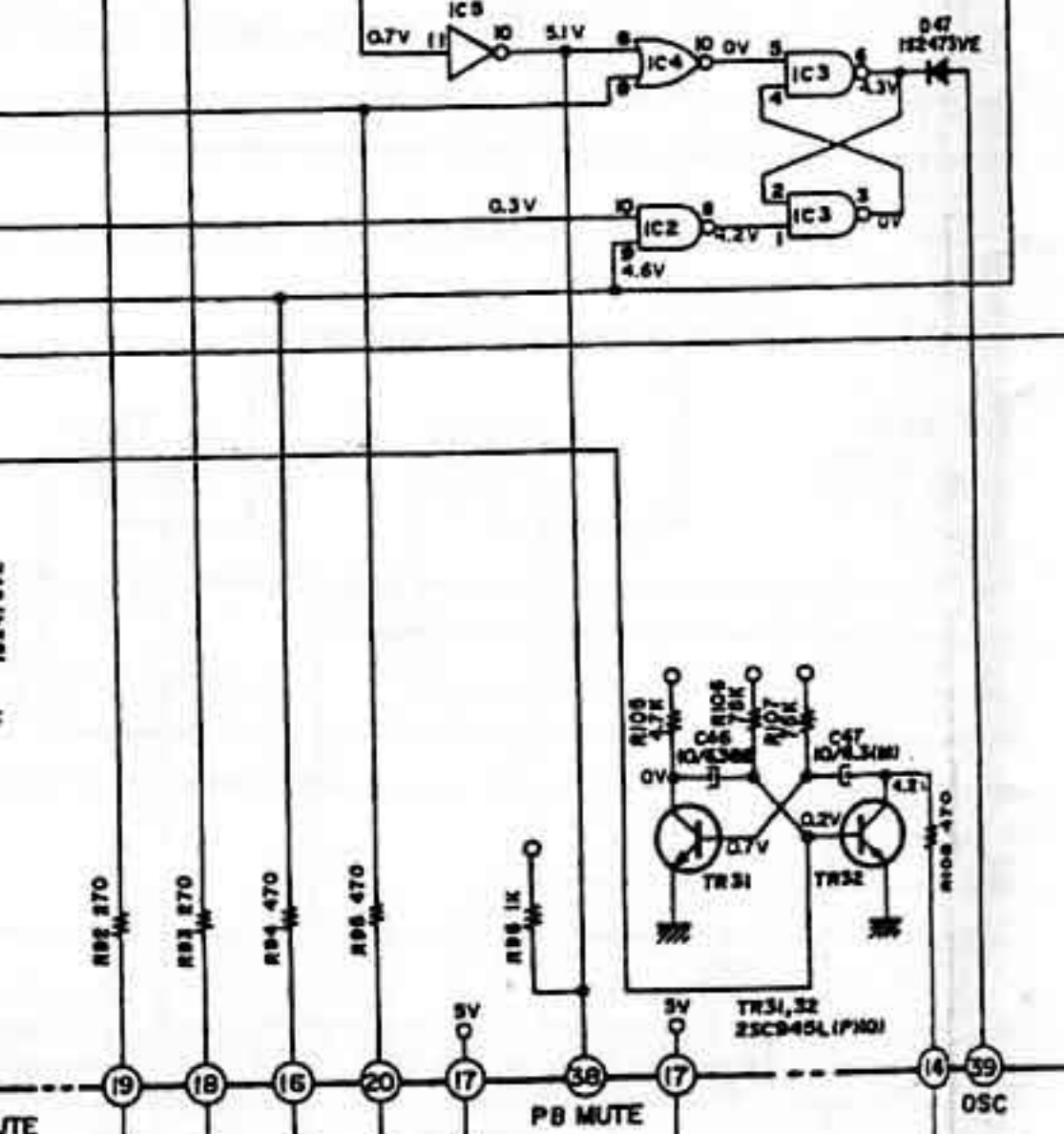
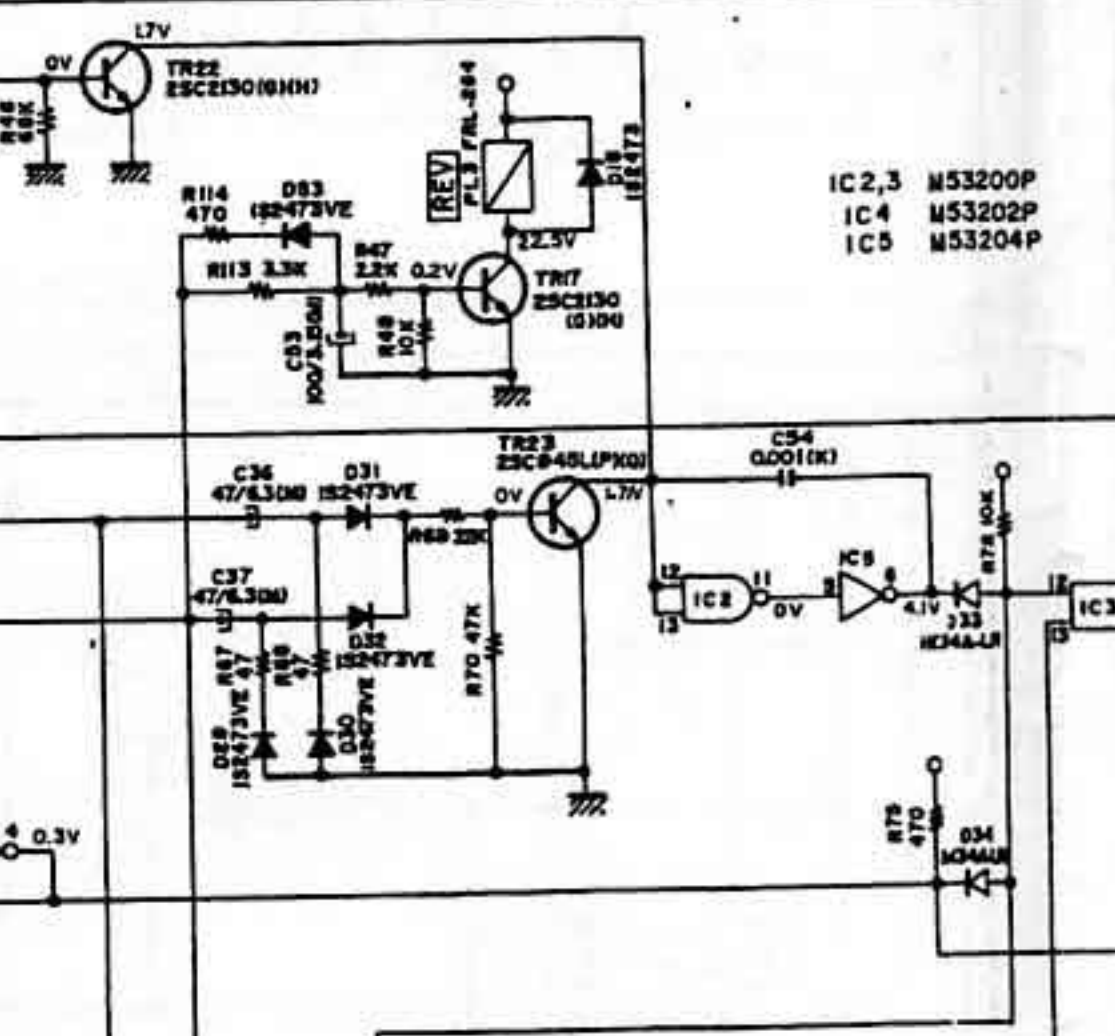
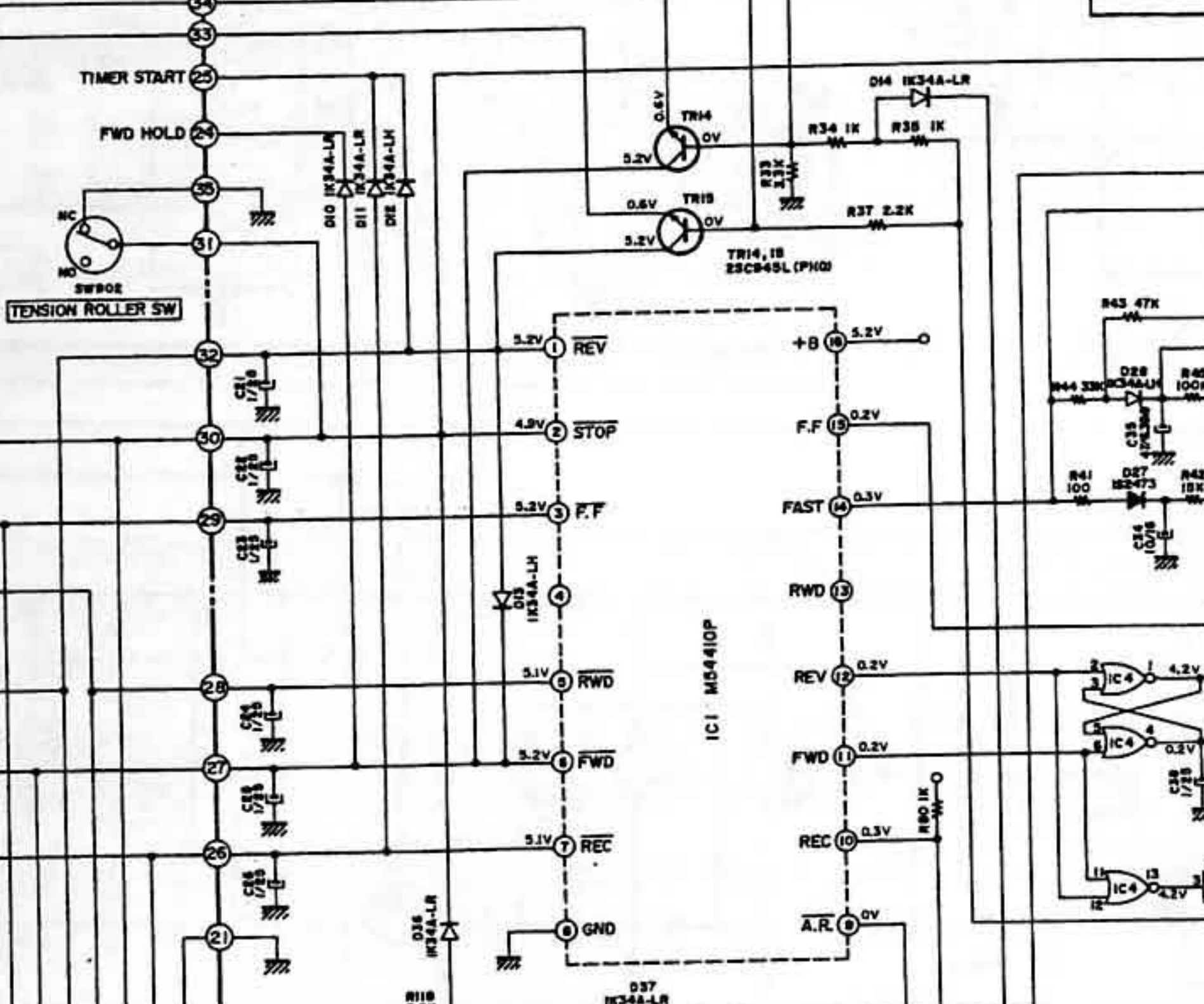
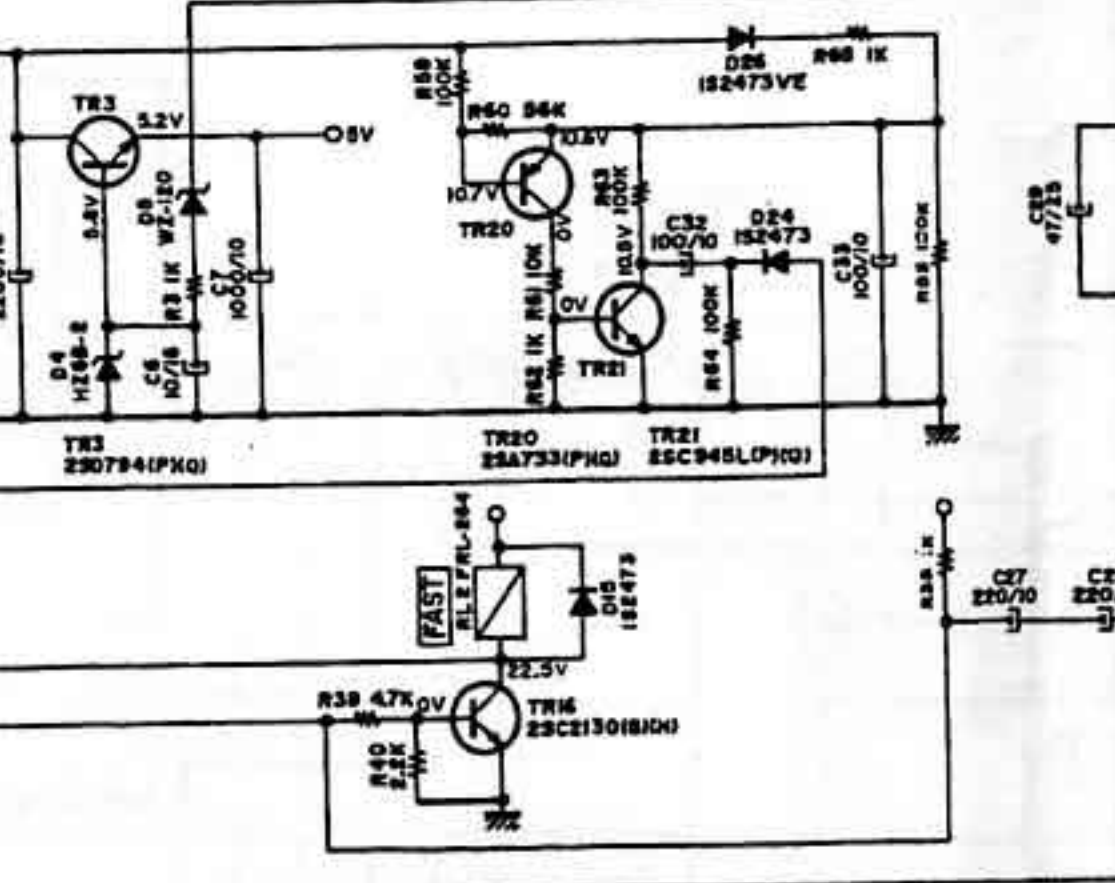
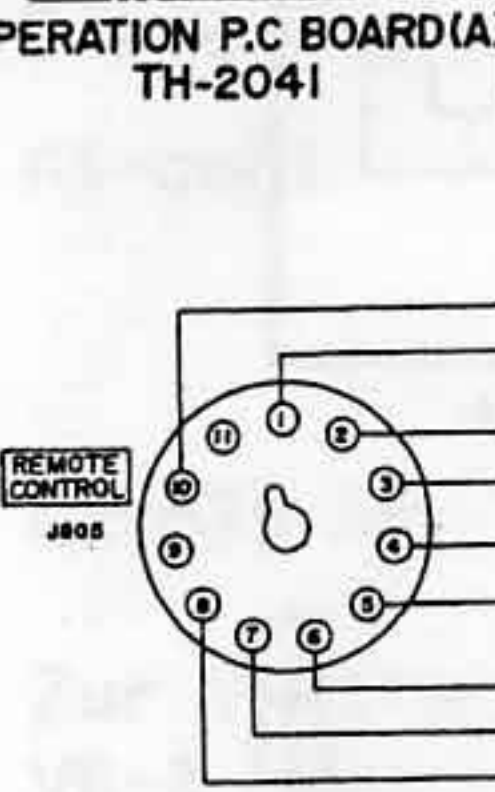
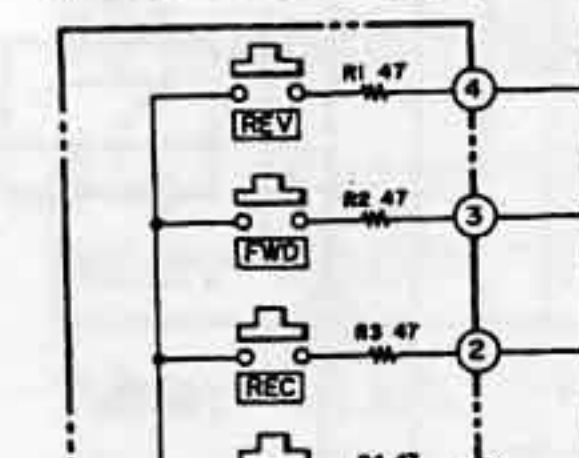
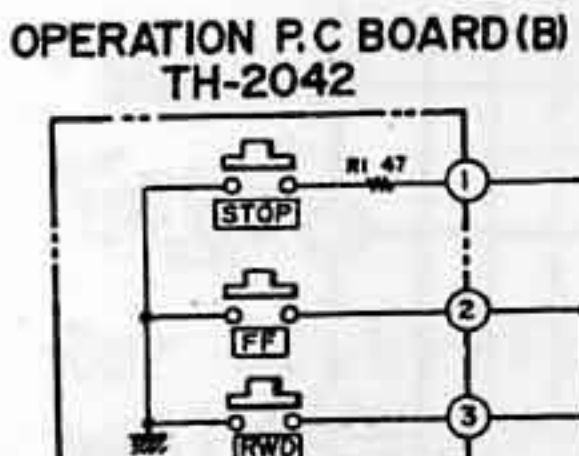
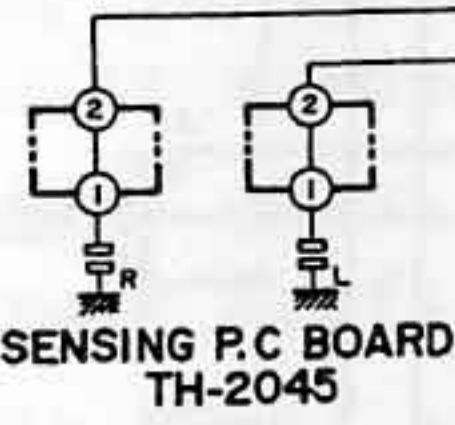
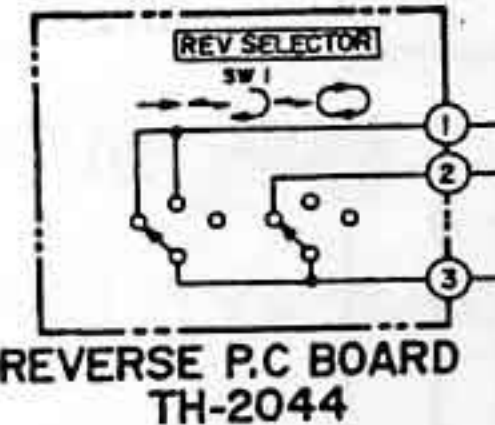
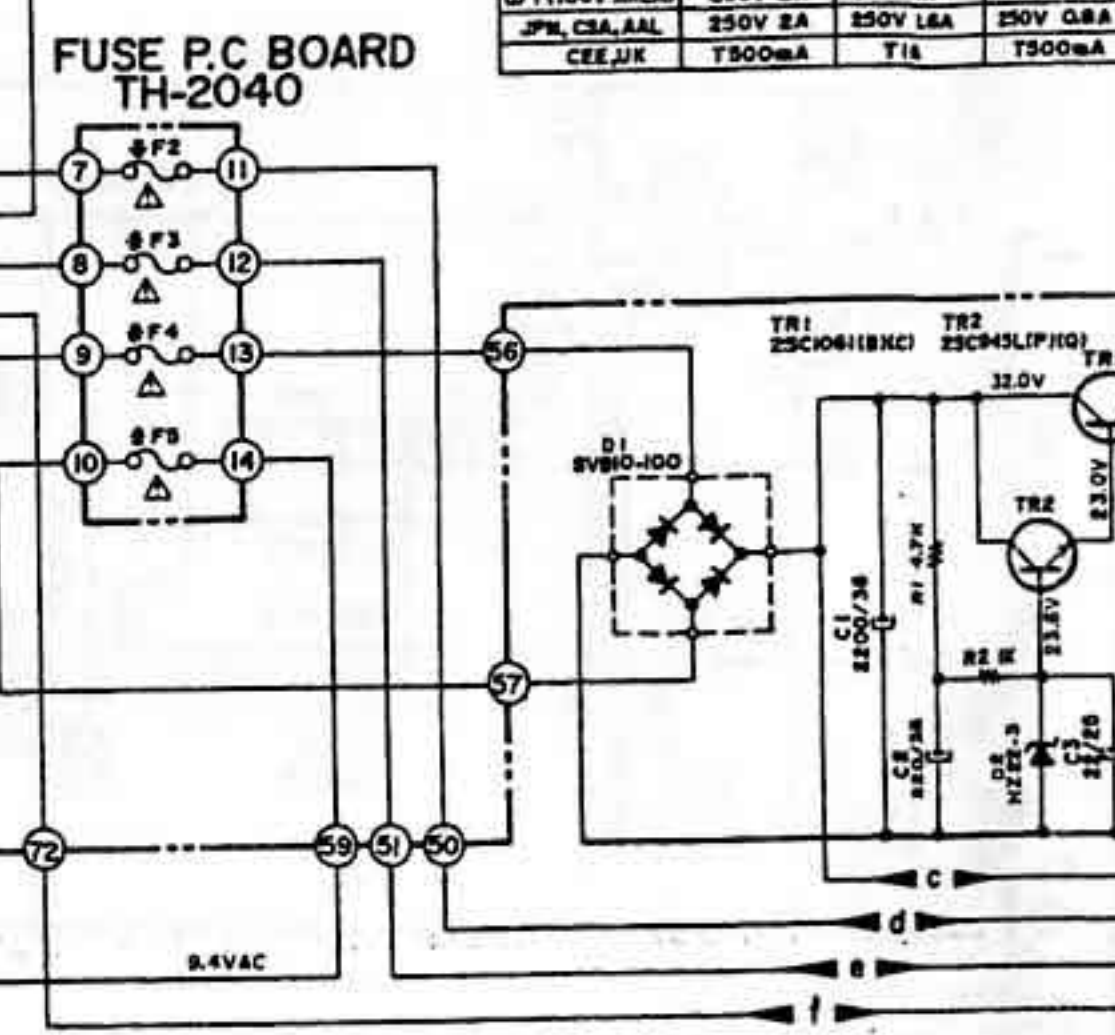
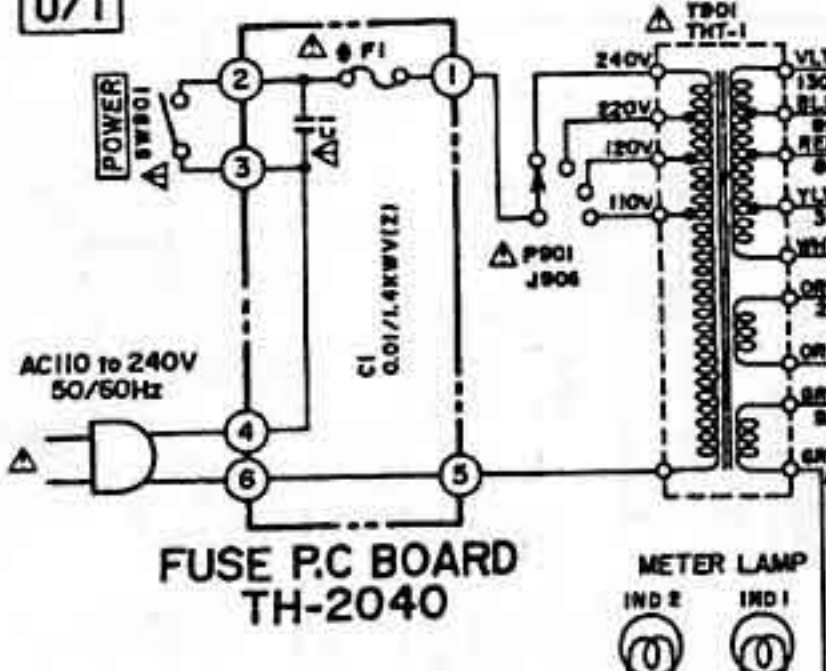
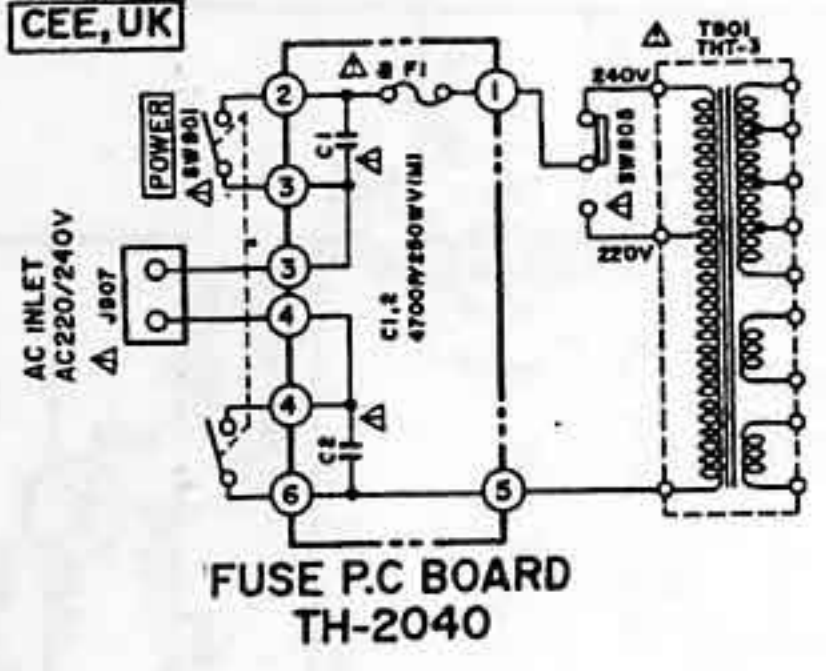
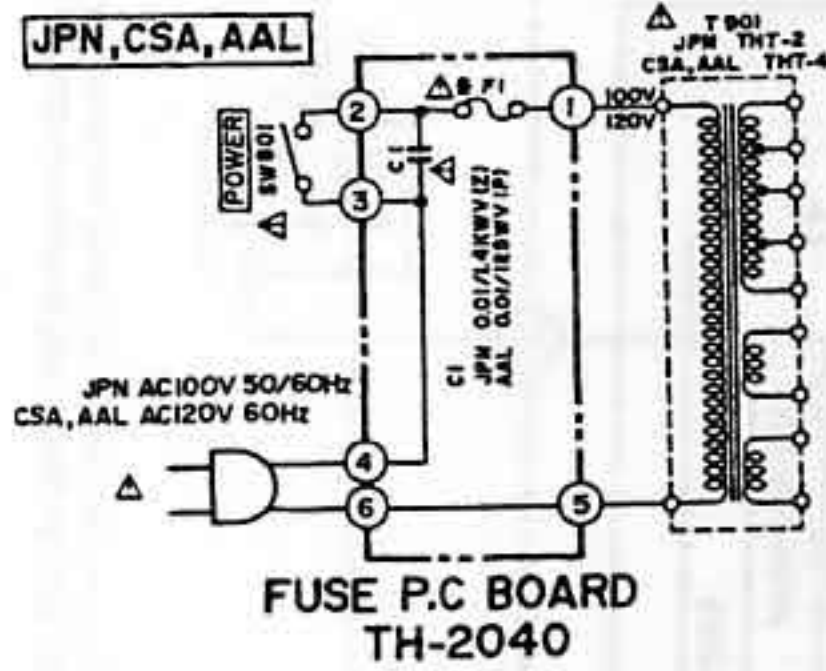

F1	F2	F3	F4	F5
250V 1A	250V 1.5A	250V 2A	250V 3A	250V 5A
250V 10A	250V 15A	250V 20A	250V 25A	250V 30A
250V 40A	250V 50A	250V 60A	250V 70A	250V 80A
250V 90A	250V 100A	250V 110A	250V 120A	250V 130A
250V 140A	250V 150A	250V 160A	250V 170A	250V 180A
250V 190A	250V 200A	250V 210A	250V 220A	250V 230A
250V 240A	250V 250A	250V 260A	250V 270A	250V 280A
250V 290A	250V 300A	250V 310A	250V 320A	250V 330A
250V 340A	250V 350A	250V 360A	250V 370A	250V 380A
250V 390A	250V 400A	250V 410A	250V 420A	250V 430A
250V 440A	250V 450A	250V 460A	250V 470A	250V 480A
250V 490A	250V 500A	250V 510A	250V 520A	250V 530A
250V 540A	250V 550A	250V 560A	250V 570A	250V 580A
250V 590A	250V 600A	250V 610A	250V 620A	250V 630A
250V 640A	250V 650A	250V 660A	250V 670A	250V 680A
250V 690A	250V 700A	250V 710A	250V 720A	250V 730A
250V 740A	250V 750A	250V 760A	250V 770A	250V 780A
250V 790A	250V 800A	250V 810A	250V 820A	250V 830A
250V 840A	250V 850A	250V 860A	250V 870A	250V 880A
250V 890A	250V 900A	250V 910A	250V 920A	250V 930A
250V 940A	250V 950A	250V 960A	250V 970A	250V 980A
250V 990A	250V 1000A			

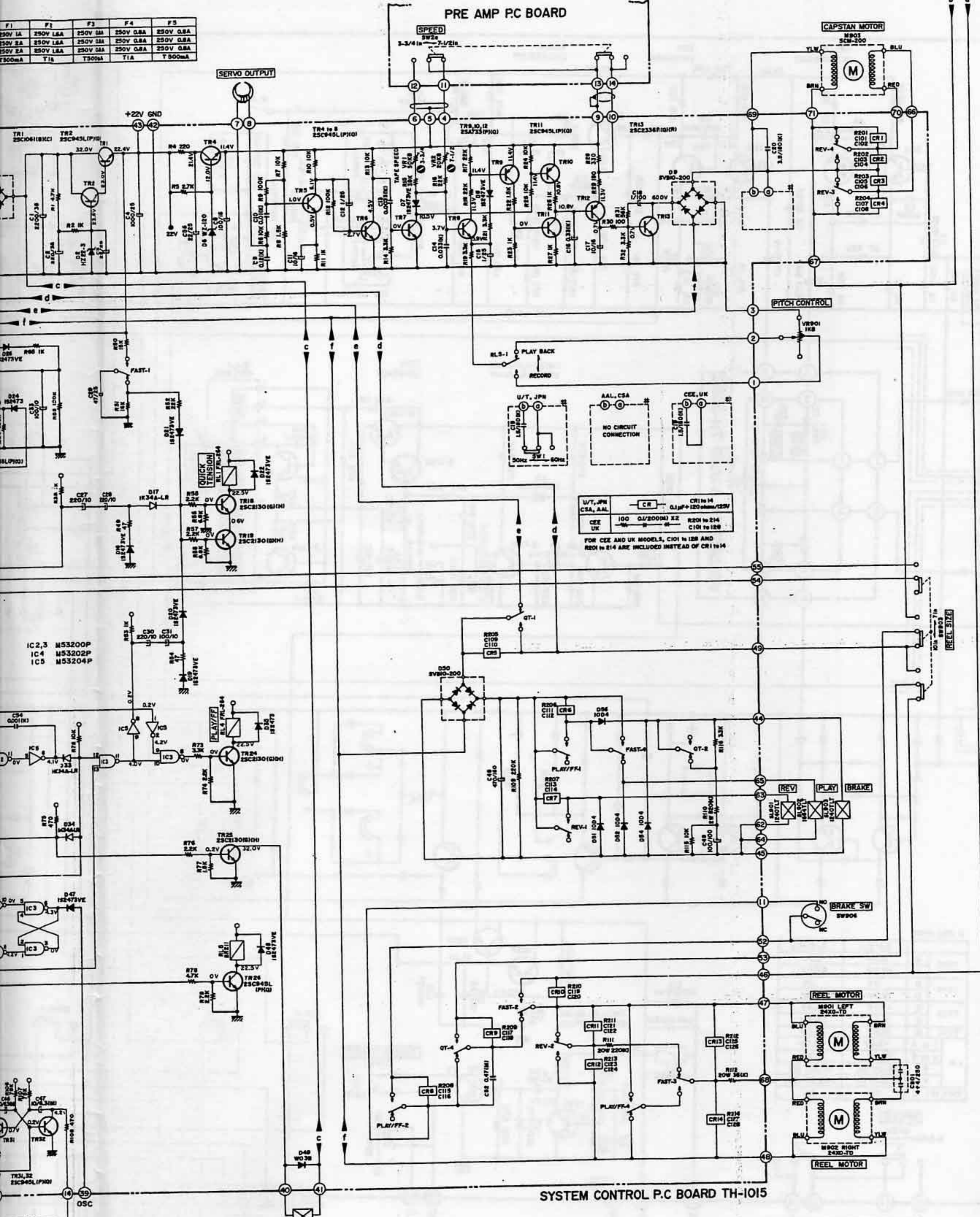

GX-635D/DB
 SCHEMATIC DIAGRAM
 No.2-1 1562416A

VII. HEAD ADJUSTMENT

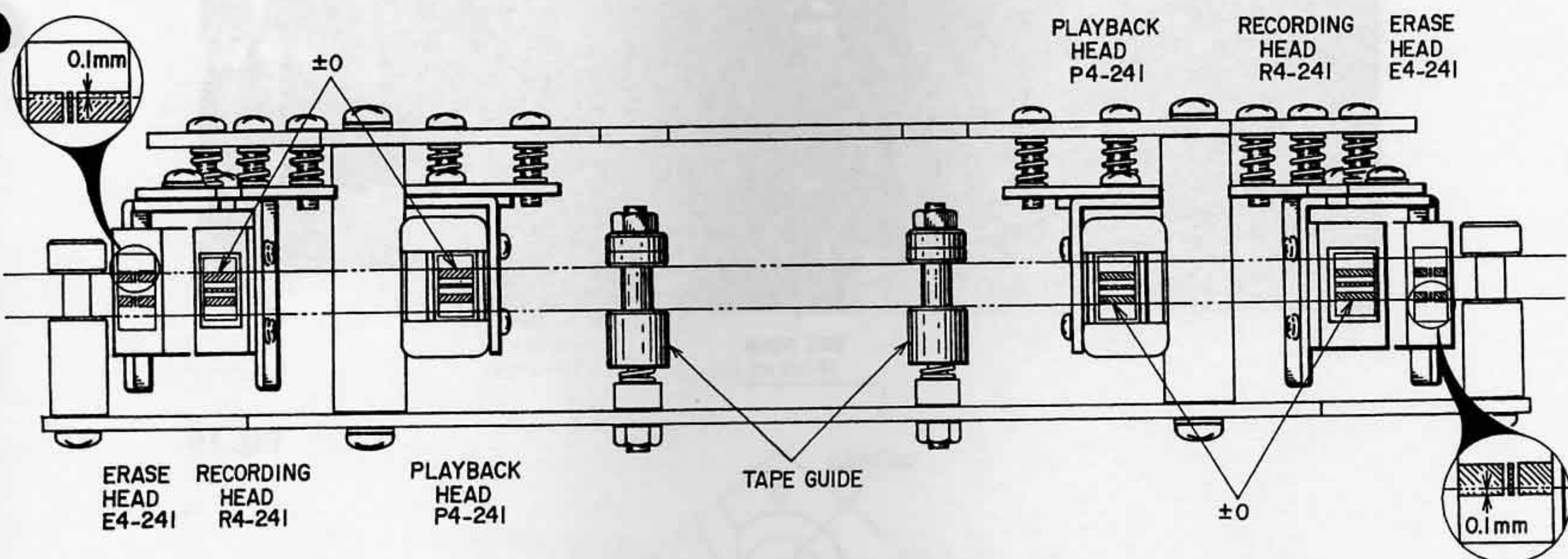
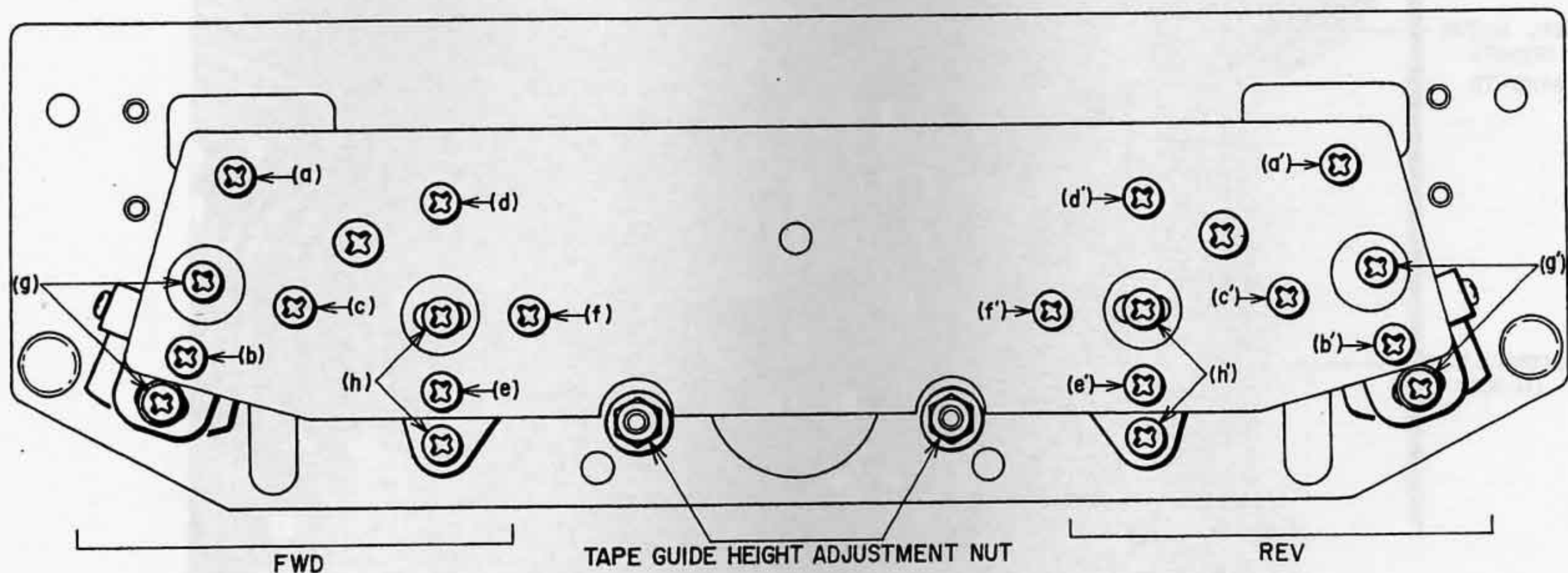

Fig. 17

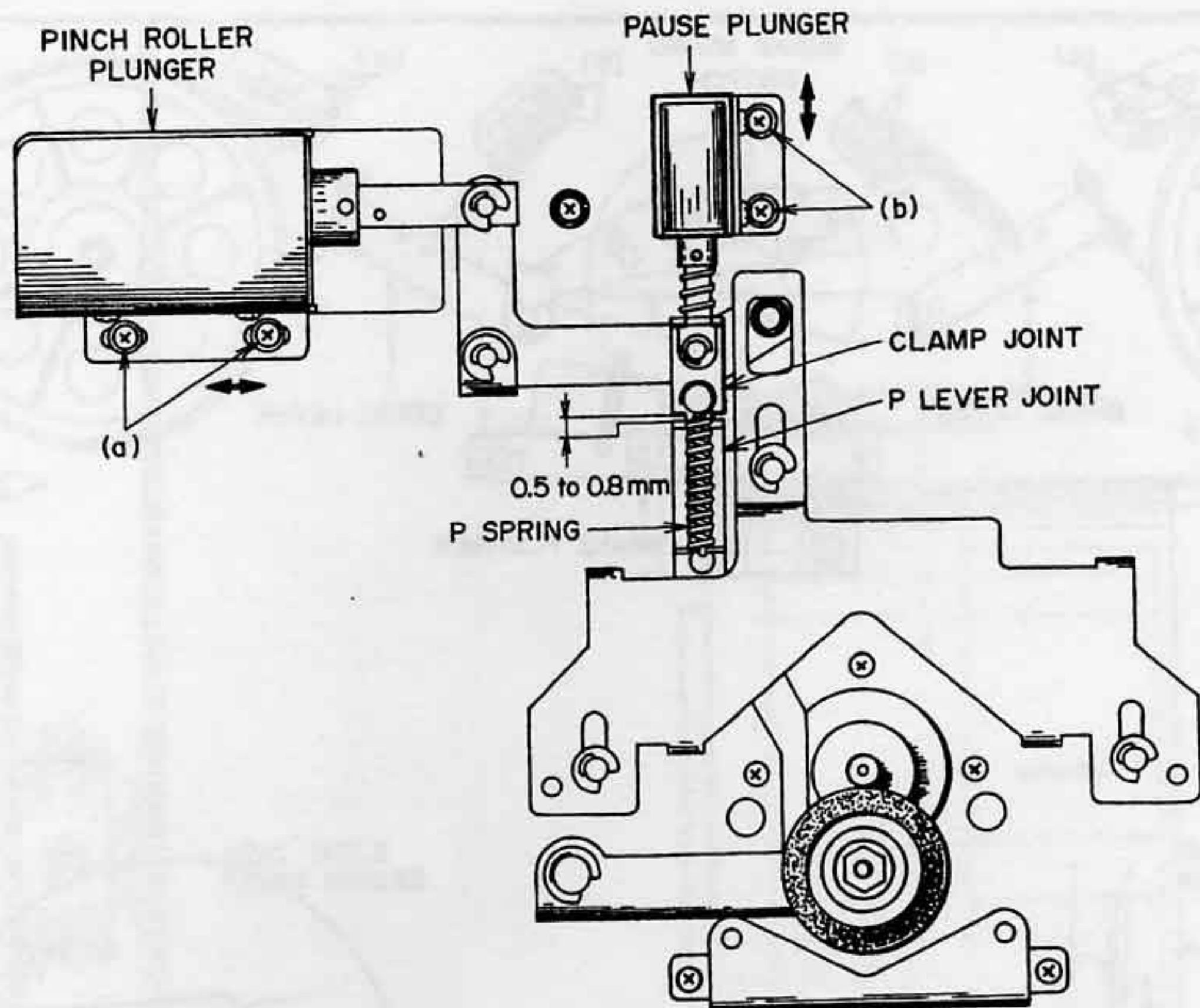

Fig. 14

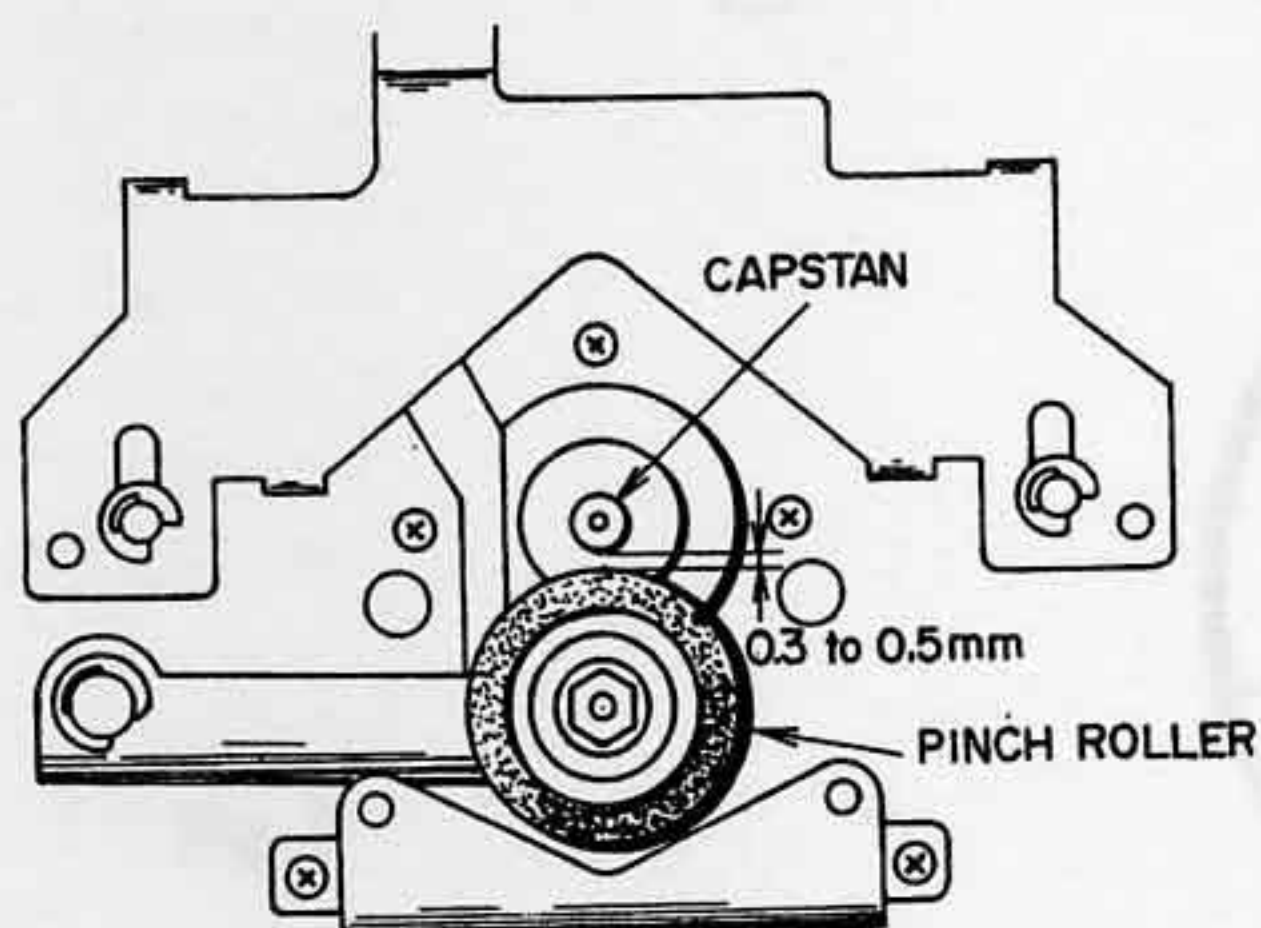

Fig. 15

7. PINCH ROLLER POSITION

ADJUSTMENT (Refer to Fig. 14)

At the play mode, the gap between the clamp joint and the P lever joint should be 0.5 to 0.8 mm. Adjust the pinch roller plunger position with screws (a).

8. PAUSE PLUNGER POSITON

ADJUSTMENT (Refer to Figs. 14, 15)

At the pause mode, the gap between the capstan and the pinch roller should be 0.3 to 0.5 mm. Adjust the pause plunger position with screws (b).

9. PINCH ROLLER PRESSURE

ADJUSTMENT

Connect a 2 kg spring gauge to the pinch roller fixing screws. Pull down the pinch roller and then let it slowly move back. Check that the spring gauge reads $1.2 \text{ kg} \pm 200\text{g}$ at the moment the pinch roller touches the capstan and starts rolling. If it reads otherwise, replace the P spring (See Fig. 14).