

SERVICE MANUAL

PARTS LIST

MODEL GXC-570DII

AKAI



AKAI STEREO CASSETTE DECK

MODEL GXC-570D II

SECTION 1	SERVICE MANUAL	3
SECTION 2	PARTS LIST	39
SECTION 3	SCHEMATIC DIAGRAM	64

SECTION 1

SERVICE MANUAL

TABLE OF CONTENTS

I.	TECHNICAL DATA	4
II.	DISMANTLING OF UNIT	5
III.	CONTROLS	6
IV.	PRINCIPAL PARTS LOCATION	7
V.	CIRCUIT OPERATING PRINCIPLES	8
	1. SYSTEM CONTROL OPERATION	8
	2. TOUCH BUTTON OPERATION	16
VI.	MECHANISM ADJUSTMENT	18
	1. FLYWHEEL THRUST LOOSE PLAY ADJUSTMENT	18
	2. REEL TABLE INSTALLATION POSITION ADJUSTMENT	18
	3. PLAY PLUNGER INSTALLATION POSITION ADJUSTMENT	19
	4. PAUSE PLUNGER INSTALLATION POSITION ADJUSTMENT	19
	5. PINCH ROLLER PRESSURE ADJUSTMENT	20
	6. TAKE-UP TORQUE AT VARIOUS MODES AND TORQUE MEASURING METHOD	20
	7. LID PANEL POSITION ADJUSTMENT	20
VII.	HEAD ADJUSTMENT	21
	1. TAPE GUIDE HEIGHT ADJUSTMENT	21
	2. HEIGHT ADJUSTMENT OF RECORDING/PLAYBACK COMBINATION HEAD	21
	3. AZIMUTH ALIGNMENT ADJUSTMENT OF RECORDING/PLAYBACK COMBINATION HEAD	21
VIII.	AMPLIFIER ADJUSTMENT	22
IX.	DC RESISTANCE OF VARIOUS COILS	24
X.	CLASSIFICATION OF VARIOUS P.C BOARDS	25
	1. RELATION OF P.C BOARD TITLE AND IDENTIFICATION NUMBER	25
	2. COMPOSITION OF VARIOUS P.C BOARDS	26

For basic adjustments, measuring methods, and operating principles, refer to GENERAL OPERATING PRINCIPLES AND ADJUSTMENTS.

I. TECHNICAL DATA

TRACK SYSTEM	4 track, 2 channel Stereo System
TAPE	Philips Type Cassette
TAPE SPEED	1-7/8 ips (Pitch Control $\pm 6\%$)
WOW & FLUTTER	Less than 0.06% WRMS, 0.17% (DIN 45500. 45507)
FREQUENCY RESPONSE	35 to 15,000 Hz ± 3 dB, using LN tape 35 to 16,000 Hz ± 3 dB, using LH tape 35 to 17,000 Hz ± 3 dB, using CrO ₂ (SA) tape 35 to 19,000 Hz ± 3 dB, using FeCr tape
DISTORTION (1,000 Hz "0" VU)	Less than 1.0% using LN tape Less than 1.0% using LH tape Less than 1.5% using CrO ₂ (SA) tape Less than 1.5% using FeCr tape
SIGNAL TO NOISE RATIO	Better than 51 dB using LN tape Better than 51 dB using LH tape Better than 52 dB using CrO ₂ (SA) tape Better than 52 dB using FeCr tape (measured via tape with peak recording level of +5 VU) Dolby N.R. switch ON: Improves up to 10 dB above 5 kHz
ERASE RATIO	Better than 70 dB
BIAS FREQUENCY	100 kHz
HEADS	(3): GX recording head, GX playback head and erase head (3 head system)
MOTORS	(3): One DC FG Servo motor for capstan drive, and two DC motors for reel drive
F.F. & REWIND TIME	50 sec. using a C-60 cassette tape
OUTPUT JACKS	Line (2): 410 mV (0 VU) Required load impedance: more than 47 kohms Phone (1): 300 mV/8 ohms (Variable at Max Volume)
INPUT JACKS	Microphone (2): 0.25 mV (Input impedance 2.4 kohms) Required microphone impedance: 600 ohms Line (2): 70 mV (Input impedance 100 kohms)
SEMICONDUCTOR	Transistors: 98, Diodes: 112, FETs: 4, ICs: 17
POWER REQUIREMENTS	CSA, UL & LA model: 120V/60 Hz Australia model: 240V/50 Hz Japan model: 100V, 50/60 Hz Other models: 110 to 120/220 to 240V, 50/60 Hz
DIMENSIONS	440 (W) x 255 (H) x 225 (D) mm (17.3 x 10.0 x 8.9")
WEIGHT	9.5 kg (21.0 lbs)

* For improvement purpose, specifications and design are subject to change without notice.

* "Dolby" and the Double D symbol are trademarks of Dolby Laboratories.

(Manufactured under license from Dolby Laboratories.)

II. DISMANTLING OF UNIT

In case of trouble, etc. necessitating disassembly, please disassemble in the order shown in photographs. Reassemble in reverse order.

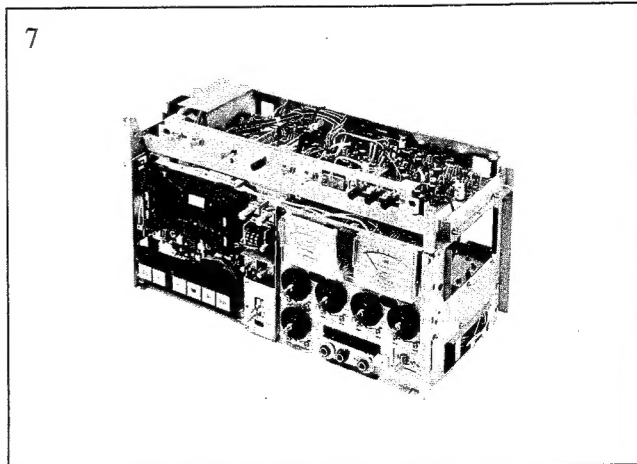
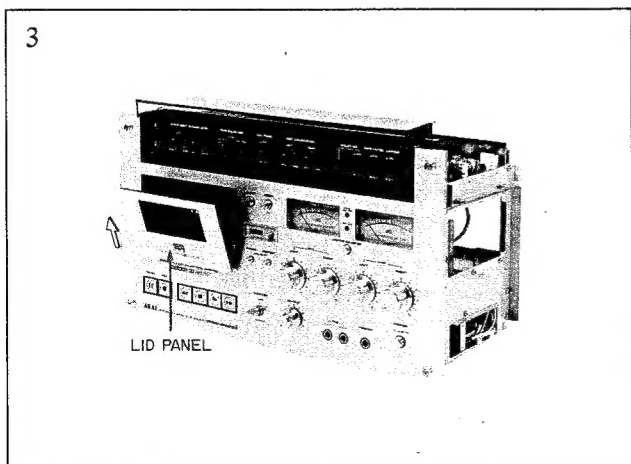
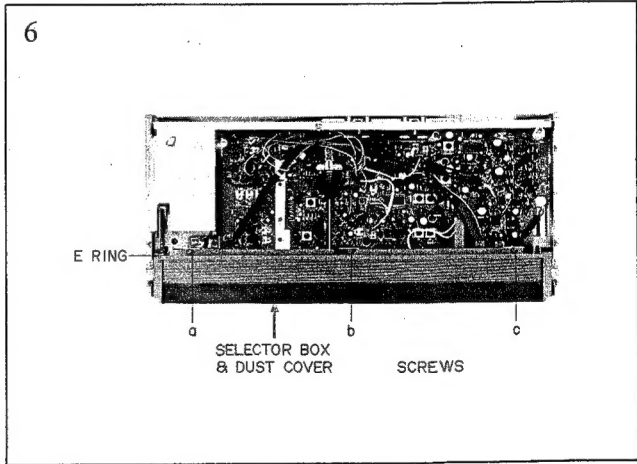
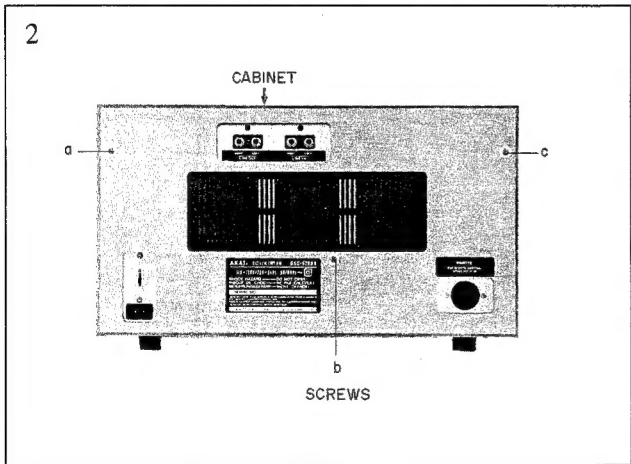
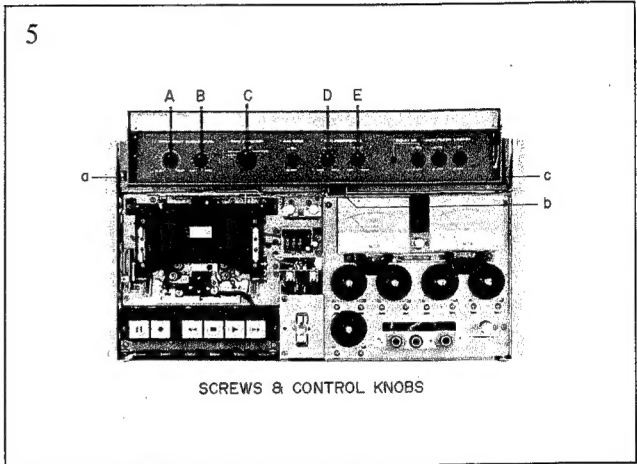
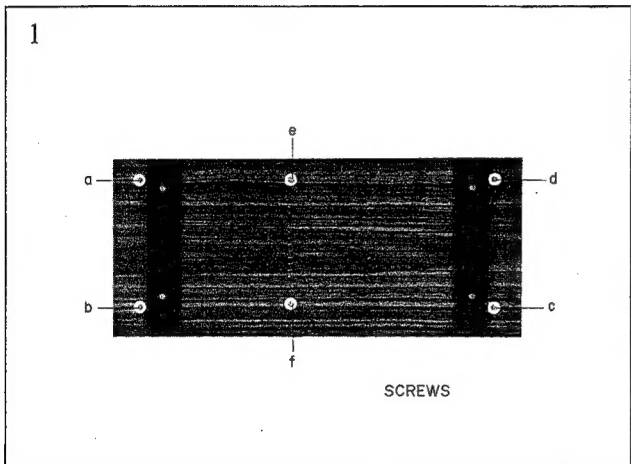
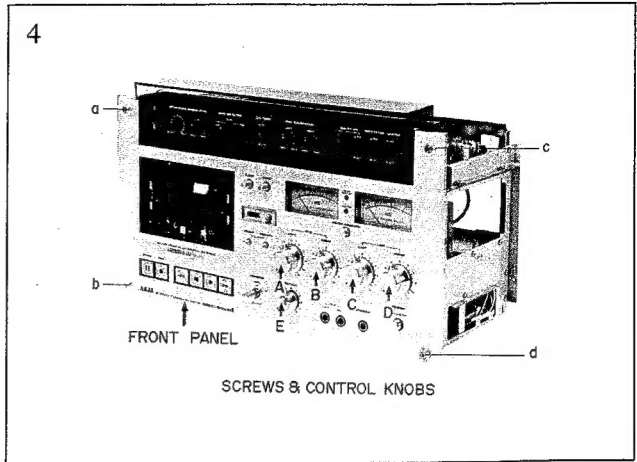

III. CONTROLS

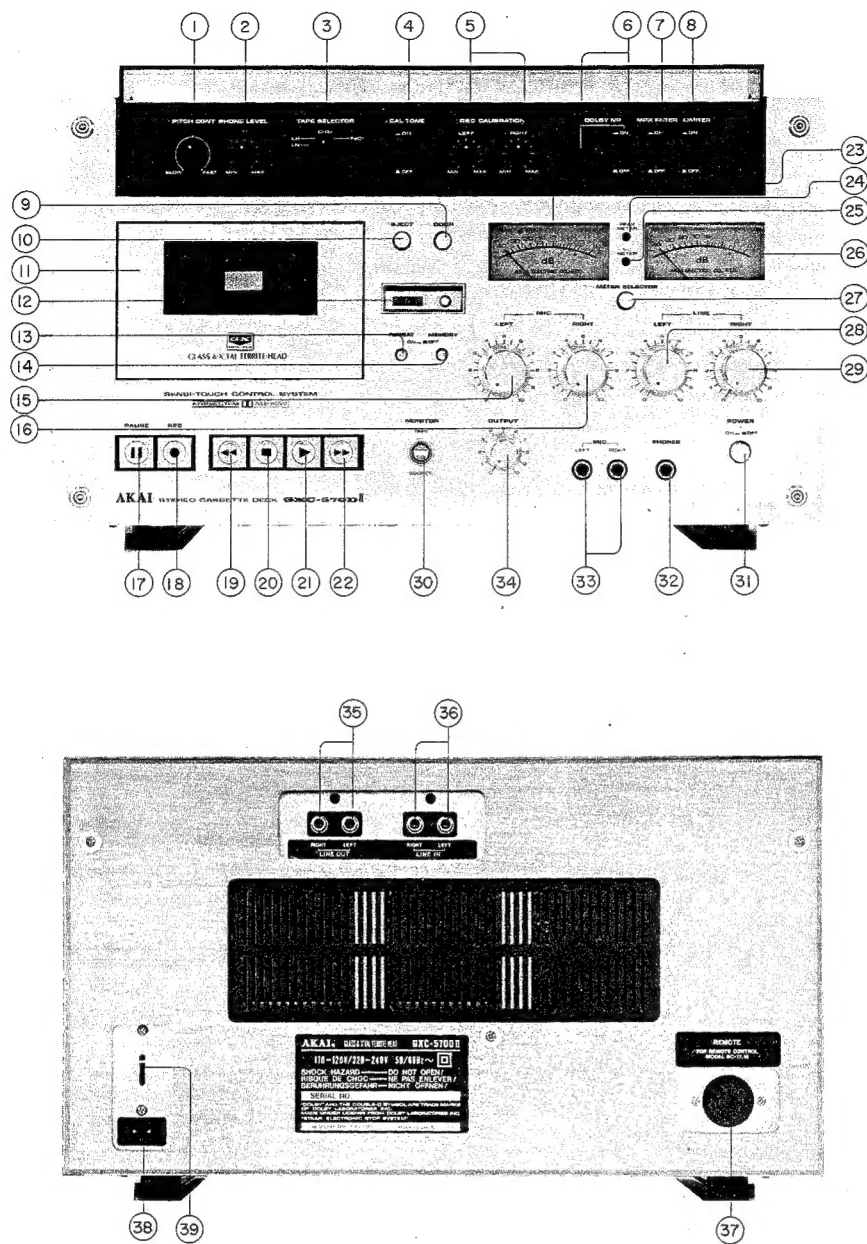

Fig. 1 Controls

- | | |
|--|--|
| 1. PITCH CONTROL | 21. PLAY BUTTON AND INDICATOR LAMP |
| 2. PHONE LEVEL CONTROL | 22. FAST FORWARD BUTTON AND INDICATOR LAMP |
| 3. TAPE SELECTOR | 23. LEFT VU METER/PEAK METER |
| 4. CAL TONE SWITCH | 24. PEAK METER INDICATOR |
| 5. REC CALIBRATION CONTROLS (Left and Right) | 25. VU METER INDICATOR |
| 6. DOLBY N.R. SWITCH AND INDICATOR LAMP | 26. RIGHT VU METER/PEAK METER |
| 7. MPX FILTER SWITCH | 27. METER SELECTOR |
| 8. LIMITER SWITCH | 28. LEFT LINE RECORDING LEVEL CONTROL |
| 9. DOOR SWITCH | 29. RIGHT LINE RECORDING LEVEL CONTROL |
| 10. EJECT SWITCH | 30. TAPE MONITOR SWITCH |
| 11. CASSETTE RECEPTACLE LID | 31. POWER SWITCH |
| 12. INDEX COUNTER AND RESET BUTTON | 32. HEADPHONE JACK |
| 13. REPEAT BUTTON | 33. MICROPHONE JACKS (Left and Right) |
| 14. MEMORY REWIND BUTTON | 34. OUTPUT LEVEL CONTROL |
| 15. LEFT MICROPHONE RECORDING LEVEL CONTROL | 35. LINE OUTPUT JACKS (Left and Right) |
| 16. RIGHT MICROPHONE RECORDING LEVEL CONTROL | 36. LINE INPUT JACKS (Left and Right) |
| 17. PAUSE BUTTON AND INDICATOR LAMP | 37. REMOTE CONTROL JACK |
| 18. RECORDING BUTTON AND INDICATOR LAMP | 38. AC INLET |
| 19. REWIND BUTTON AND INDICATOR LAMP | 39. VOLTAGE SELECTOR SWITCH |
| 20. STOP BUTTON | |

IV. PRINCIPAL PARTS LOCATION

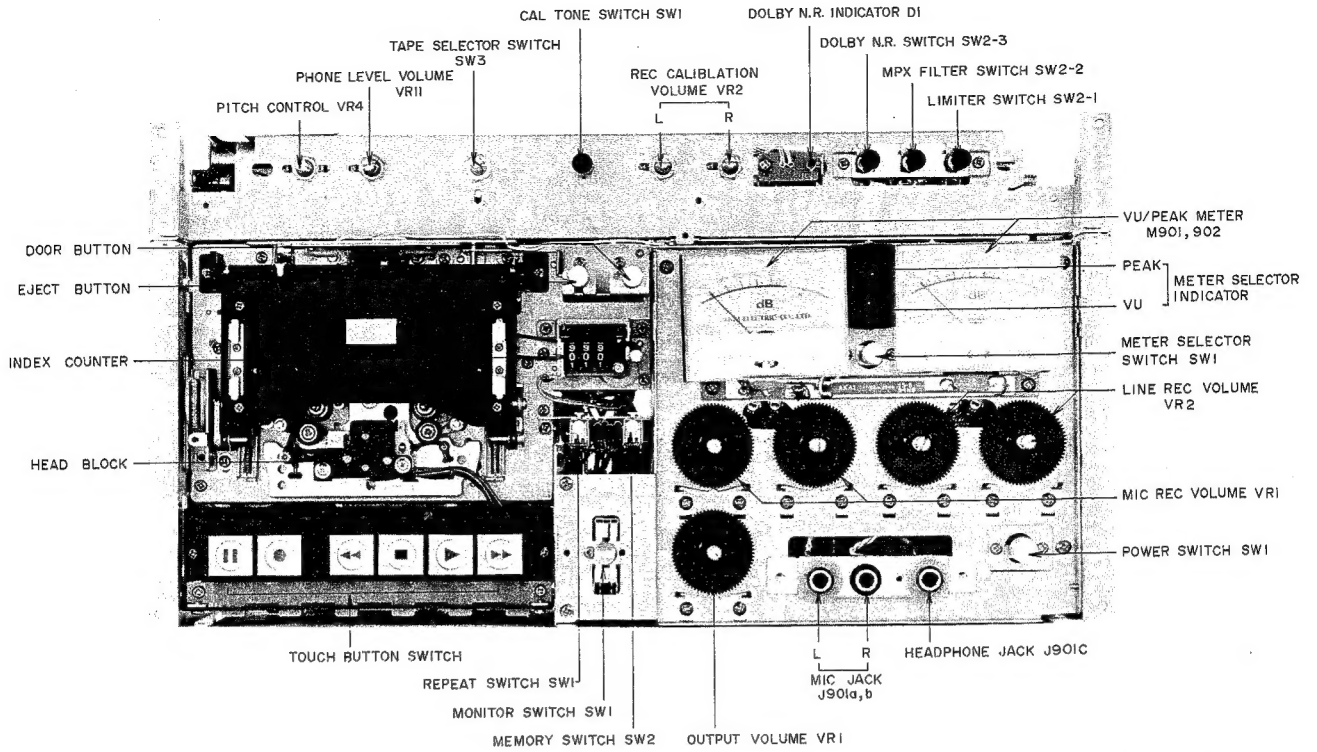

Fig. 2 Front View

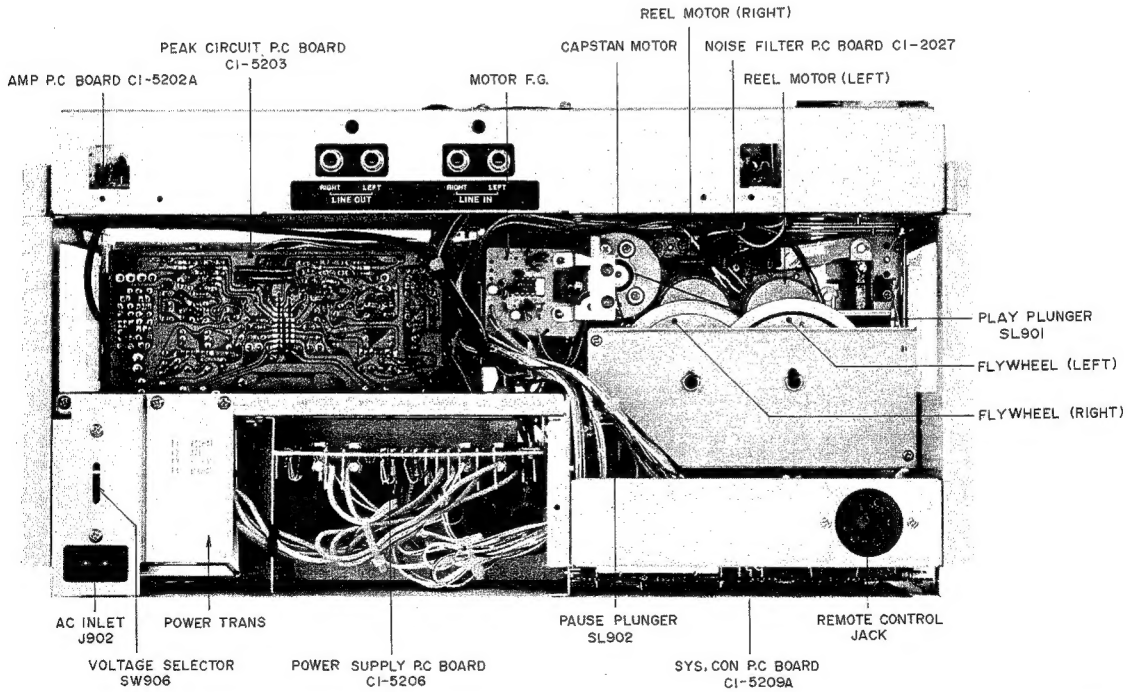
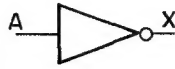
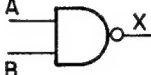
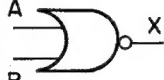

Fig. 3 Rear View

V. CIRCUIT OPERATING PRINCIPLES

1. SYSTEM CONTROL OPERATION

	SYMBOL	TRUTH TABLE															
NOT CIRCUIT	 $X = \bar{A}$	<table border="1"> <thead> <tr> <th>A</th> <th>X</th> </tr> </thead> <tbody> <tr> <td>0</td> <td>1</td> </tr> <tr> <td>1</td> <td>0</td> </tr> </tbody> </table>	A	X	0	1	1	0									
A	X																
0	1																
1	0																
NAND CIRCUIT	 $X = \overline{A \cdot B}$	<table border="1"> <thead> <tr> <th>A</th> <th>B</th> <th>X</th> </tr> </thead> <tbody> <tr> <td>0</td> <td>0</td> <td>1</td> </tr> <tr> <td>1</td> <td>0</td> <td>1</td> </tr> <tr> <td>0</td> <td>1</td> <td>1</td> </tr> <tr> <td>1</td> <td>1</td> <td>0</td> </tr> </tbody> </table>	A	B	X	0	0	1	1	0	1	0	1	1	1	1	0
A	B	X															
0	0	1															
1	0	1															
0	1	1															
1	1	0															
NOR CIRCUIT	 $X = \overline{A + B}$	<table border="1"> <thead> <tr> <th>A</th> <th>B</th> <th>X</th> </tr> </thead> <tbody> <tr> <td>0</td> <td>0</td> <td>1</td> </tr> <tr> <td>1</td> <td>0</td> <td>0</td> </tr> <tr> <td>0</td> <td>1</td> <td>0</td> </tr> <tr> <td>1</td> <td>1</td> <td>0</td> </tr> </tbody> </table>	A	B	X	0	0	1	1	0	0	0	1	0	1	1	0
A	B	X															
0	0	1															
1	0	0															
0	1	0															
1	1	0															

O = LOW LEVEL
1 = HIGH LEVEL

Chart-1

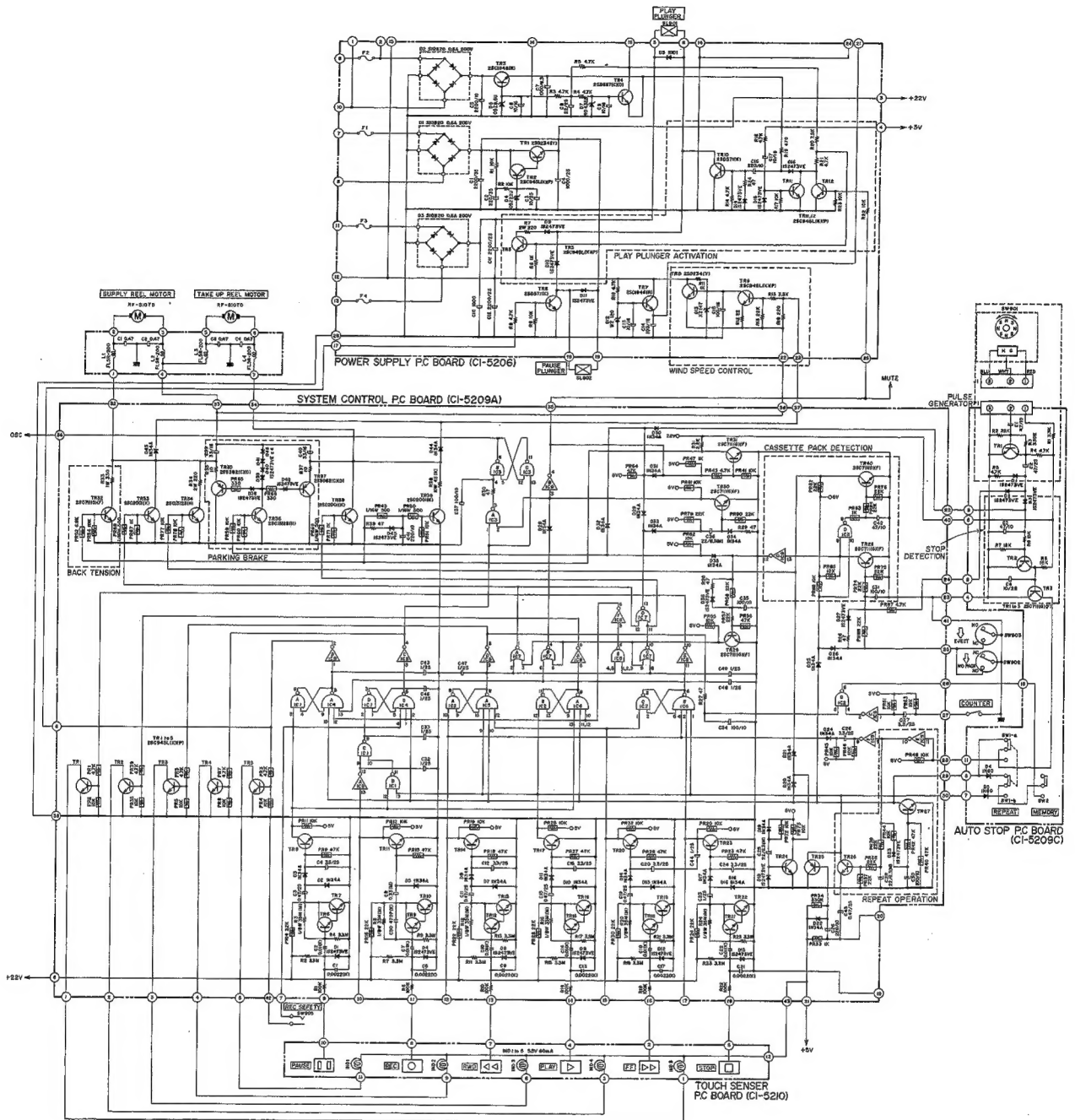

Schematic-1

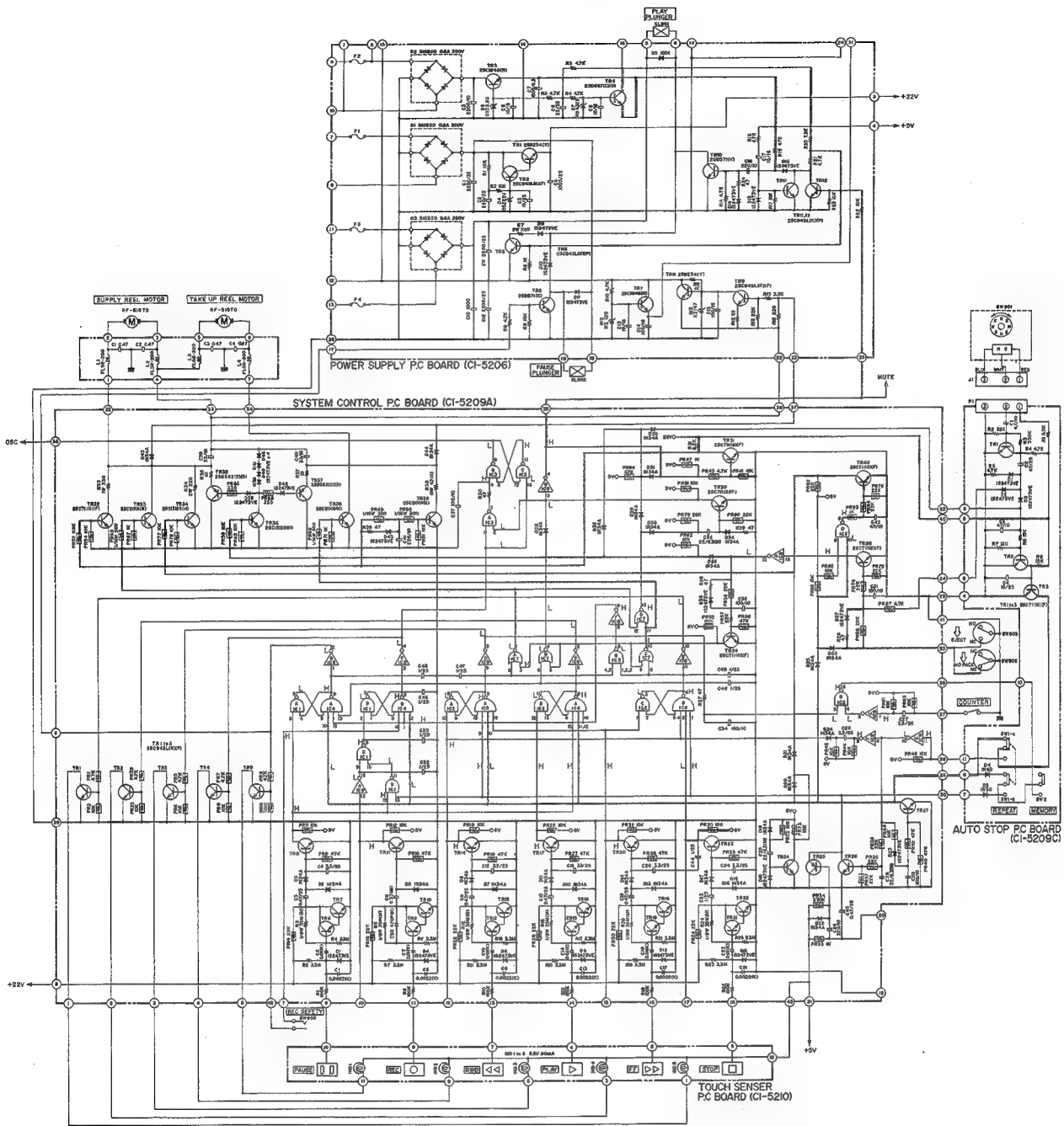

Schematic-2 Stop Mode

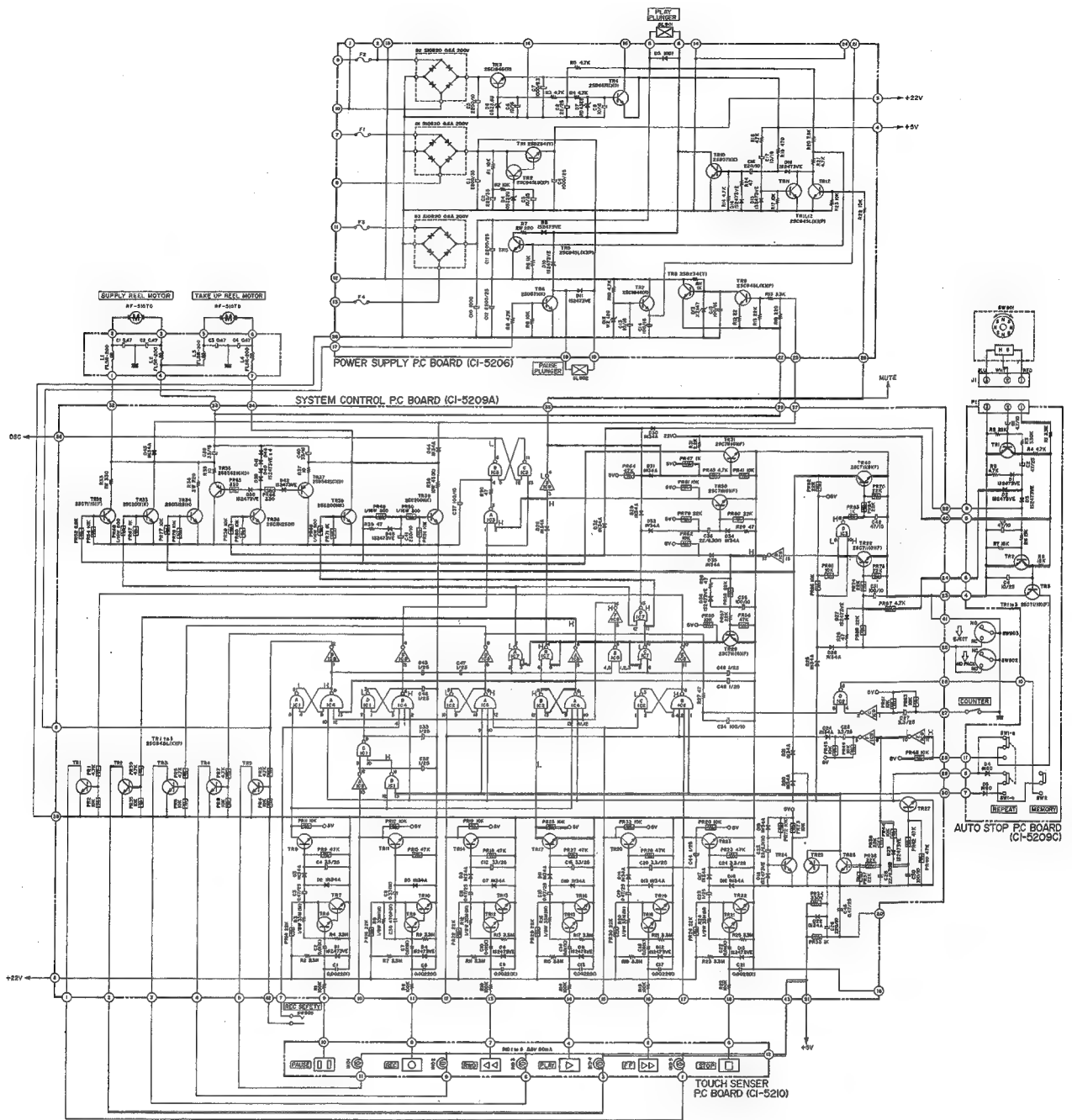

Schematic-3 Play Mode

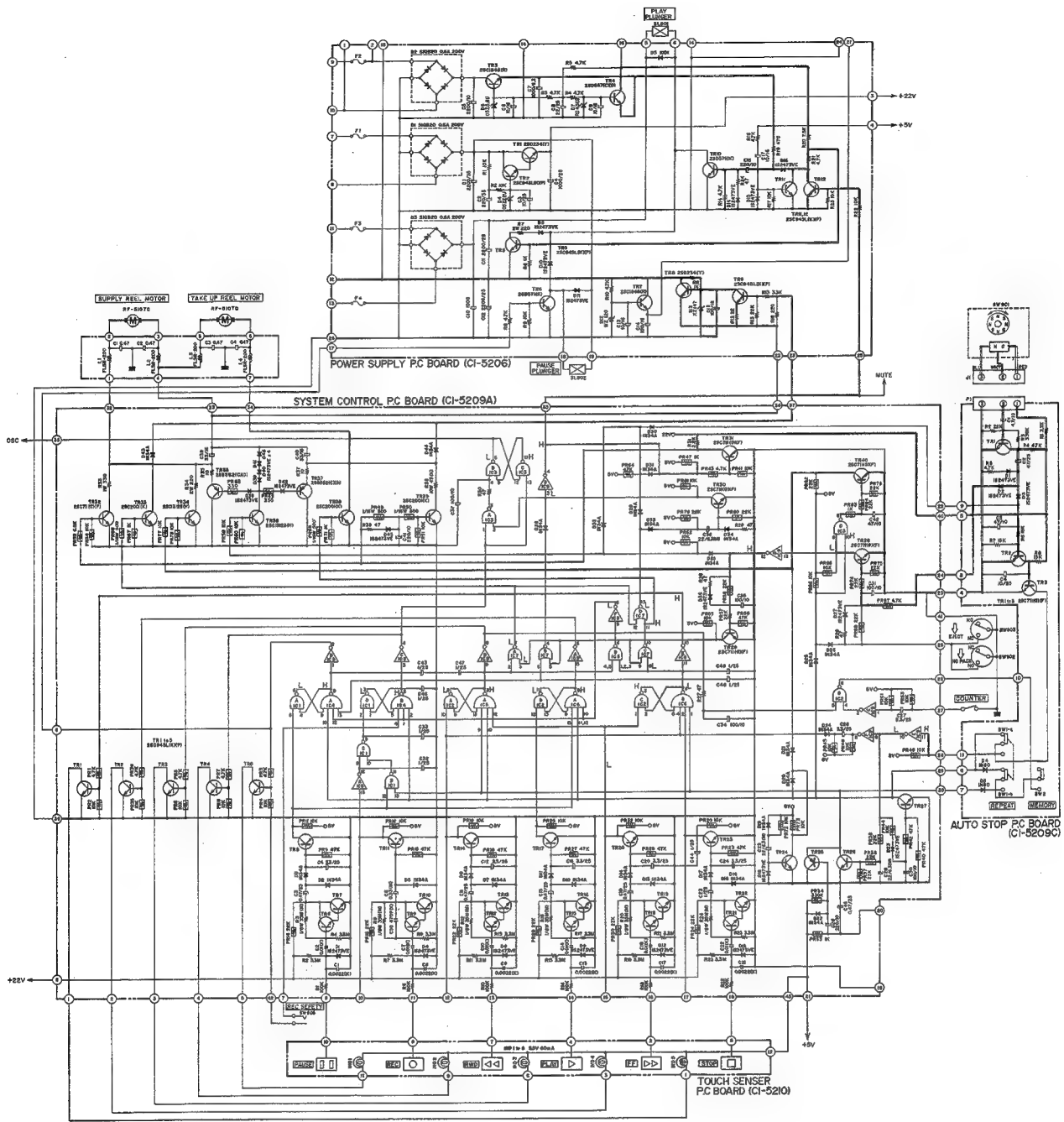

Schematic-4 FF Mode

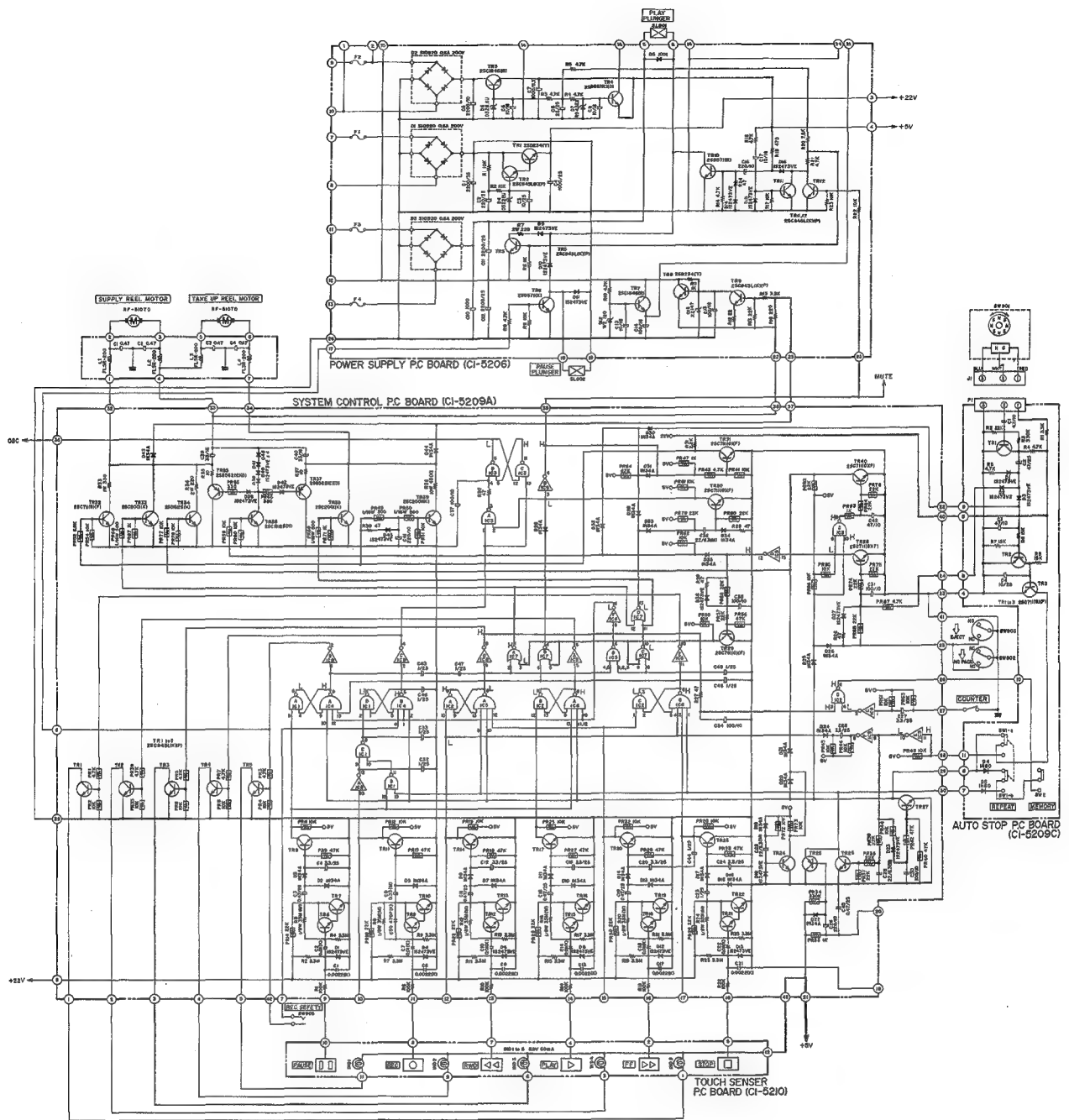

Schematic-5 RWD Mode

1-1. TAPE SLACK ELIMINATION CIRCUIT

1) The purpose of this circuit is to take up tape slack prior to operation for proper tape tension at all times. The double capstan system of this deck is vulnerable to tape tangling around the capstan when the PLAY mode is effected with a noticeable tape slack and to poor head-to-tape contact for a considerable length of time in the beginning of tape even with a slight tape slack.

2) When the cassette tape is not loaded, the cassette tape detection micro switch SW902 is CLOSED and the deck maintains TR28 OFF→TR40 ON→TR34 OFF condition. Even when the EJECT is operated to OPEN SW902, the EJECT switch SW903 is CLOSED beforehand to maintain the above TR28, TR40, TR34 condition.

However, when the cassette tape is loaded, as EJECT switch SW903 becomes OPEN and as SW902 is OPEN, the charging current flows in the order of D25→D26→PR88→C31 to charge C31.

While C31 is being charged, TR28 is OFF to result in High Level IC3D input terminals 9 and 10 and Low Level output terminal 8. This decreases the base electric potential of TR40 and TR40 turns OFF. Because TR40 collector is connected to TR34 through PR77, when TR40 turns OFF, TR34 base electric potential increases and turns ON. Thus, because electric current flows to Supply Reel Motor through R34, the Supply Reel Motor rotates to take up the tape slack.

3) Meanwhile, TR28 turns ON when C31 is charged by the electric current flowing from D25→D26→PR88→C31.

The duration of this charge is approximately 2 to 3 seconds. Or, TR28 can be turned ON in another way, when the Supply Reel Motor rotates to pull the tape, Take-up Reel Motor starts to rotate after the tape slack is completely taken up. When the Take-up Reel Motor starts to rotate, the rotary magnet within SW901 interlocked with the tape counter starts to rotate. This results in a pulse electric current to flow through the Automatic Stop Circuit C1→TR1→C2→D2 and System Control Circuit PR7→C31 to charge C31 and to turn ON TR28. In either way, when TR28 is turned ON, IC3D Low Level input terminal 9 and High Level output terminal increase TR40 base electric potential through PR83→C42→PR84 and TR40 is turned ON.

When TR40 is turned ON, the base electric potential of TR34, which is connected to TR40 collector through PR77, decreases and TR34 is turned OFF. The electric current is thereby cut from the Supply Reel Motor and Supply Reel Motor stops.

4) Also, turning ON of TR28 results in a Low Level input terminal 13 of IC9D and High Level output terminal 12. This causes TR35 base electric potential to increase through PR62 and PR59 from 5V line and turns TR35 ON. When TR35 turns ON, the electric potential of D39 cathode side decreases, and base electric potential of TR35 is thereby decreased through D38 and PR65.

At the same time, TR37 base electric potential is decreased through D42 and PR66 to turn on TR35 and TR37. For this reason, Supply and Take-up Reel Motors are supplied with electric currents to start rotation through R35, TR35 and R37, TR37, respectively. But because the rotations are in the opposite direction, the torques are toward pulling the tape on both sides which causes the tape to stand still. In this way, weak torques prevent tape slack from forming and function as a parking break.

1-2. PLAY PLUNGER OPERATION CIRCUIT

1) This circuit operates the Play Plunger by first supplying a big amount of electric current to start operation, then a small amount to maintain operation. This deck employs transistors rather than relays for the drive.

2) Because the PLAY mode of the deck results in a Low Level IC9B output terminal 4 of the System Control Circuit, base electric potential of the Power Supply Circuit TR12 connected to the output terminal 4 decreases and TR12 is turned OFF. When this happens, charging current flows from TR4 emitter to C16 through R19. Then while C16 is being charged, TR10 base electric potential increases to turn TR10 ON, and collector current flows to operate the Play Plunger. Also, when TR12 is turned OFF, TR5 base electric potential increases and TR5 is turned ON. As a result, Play Plunger maintains operation even after C16 is finished being charged and TR10 is turned OFF, because TR5 collector current flows in through D9 and R7.

3) At the instance the Power Switch is turned on in the Power Supply Circuit, TR12 is OFF from the time 5V electric voltage is introduced into the TR3 emitter to the time System Control Circuit begins operation. This causes charging current to flow to C16, to turn ON TR10, and the collector current to flow to the Play Plunger to result in a malfunction. For this reason, from the time electric voltage is introduced into the TR3 emitter to the time System Control Circuit begins operation, a charging current flows from the TR4 emitter through R16→C17→R17 to increase base electric potential of TR11 and turn it ON. When TR11 is turned ON, the D16 anode side reaches ground potential so that TR10 is at OFF condition and the plunger does not operate. Because the time it takes to charge C17 and turn on TR11 is longer than the time it takes for the System Control Circuit to operate and turn on TR12, such malfunction is prevented.

1-3 FAST FORWARD AND REWIND SPEED CONTROL CIRCUIT

1) The reel motors employed in this deck are DC motors which at a nonload condition rotates at a very high speed. Consequently, when Fast Forward or Rewind is effected, there is a possibility of tape damage due to a gradual build-up of inertia and increased revolutions. This circuit is for the purpose of controlling supply voltage to the take-up reel motor for

suppression of increased motor revolutions.

- 2) When the deck is set to Fast Forward mode, TR38 is turned ON and the take-up motor begins to rotate. In case the supply reel motor does not rotate, bias is not supplied to the base of the Power Supply P.C Board TR9 and the resistance between TR9 collector and emitter is infinite.

Therefore, a fixed bias is supplied to TR8 through R11, D13 and C15 and a fixed DC voltage is supplied to the take-up reel, to result in gradual build-up of inertia and increase in motor revolutions. However, at Fast Forward mode, the supply reel motor of this deck functions as a generator. Accordingly, the electromotive force generated by the supply reel motor passes D44 and Power Supply P.C Board R15 to become TR9 base bias, and the resistance between TR9 collector and emitter varies proportionately with the extent of the generator's electromotive force.

In other words, the resistance between TR9 collector and emitter is interconnected to TR8 base-emitter interval in parallel and varies the bias supplied to TR4.

For instance, when the take-up reel motor begins to rotate at high speed, proportionate electromotive force is generated by the supply reel motor and this generated voltage increases the resistance between TR8 collector and emitter thereby decreasing the supply voltage to the take-up reel motor. Thus the motor revolution is slowed down. In this manner, the take-up speed always corresponds with the supply reel motor speed, thus preventing high speed motor revolutions.

- 3) Speed control also functions in exactly the same way at Rewind mode. However, in this case, the right hand side reel motor functions as a generator and controls the supply voltage in order to control the left hand side reel motor revolutions. Thus the Rewind speed is controlled in the same way as at Fast Forward.

1-4 AUTOMATIC SHUT-OFF MECHANISM CIRCUIT

- 1) This circuit automatically effects Stop mode from other modes, i.e., Play, Recording, Fast Forward or Rewind modes, when tape travel stops.
- 2) The rotation of the rotary magnet within SW901 during tape travel generates pulse and TR1 of the Automatic Shut-Off Circuit repeats ON→OFF switching operation. By the switching operation of TR2, charge and discharge current flows to C2. Only when C2 is charged, C3 is charged through D3 and TR2 base electric potential increases to turn TR2 ON. When C2 is discharged, C3 discharging current flows to R6→R7→Ground and TR2 base electric potential is gradually decreased. But because C3 is charged by C2 charging current before TR2 turns OFF, the ON condition of TR2 is maintained. For this reason, TR3 base is ground electric potential and therefore, TR3 is OFF.
- 3) When tape travel stops, charging and discharging of C2 stops, discharging of C3 is completed, and TR2

is turned OFF. Consequently, TR3 base electric potential increases to turn ON and TR23 (Sys. Con P.C Board) collector connected to TR3 collector also reaches ground electric potential. As a result Stop mode is effected.

2. TOUCH BUTTON OPERATION

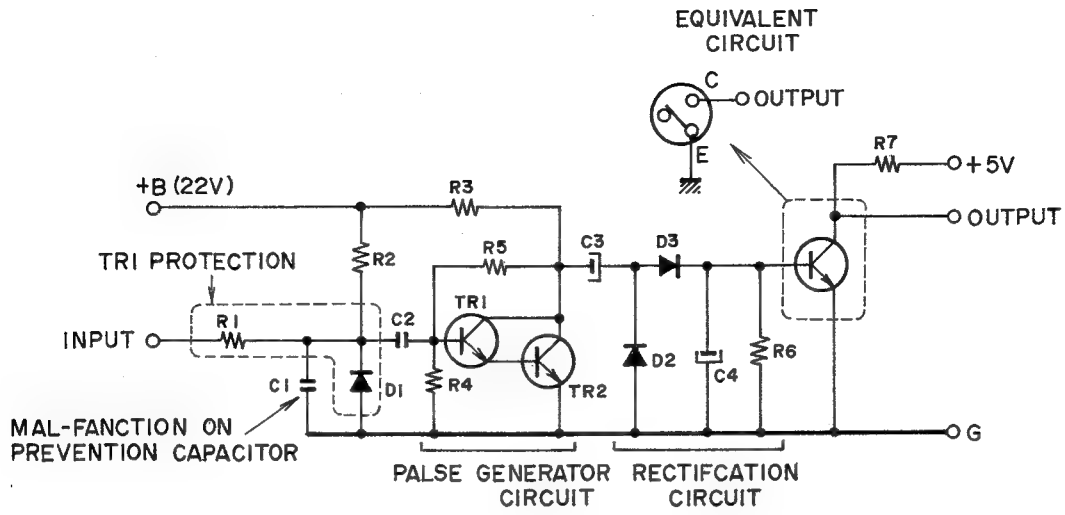

Fig. 4

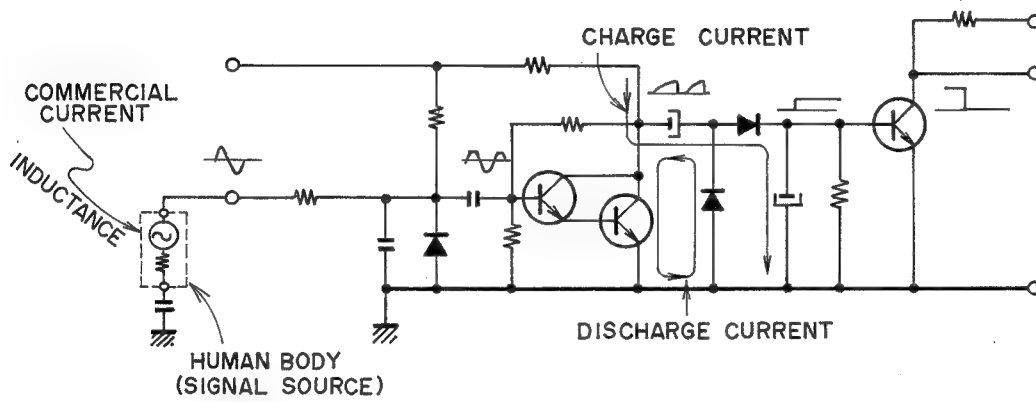

Fig. 5

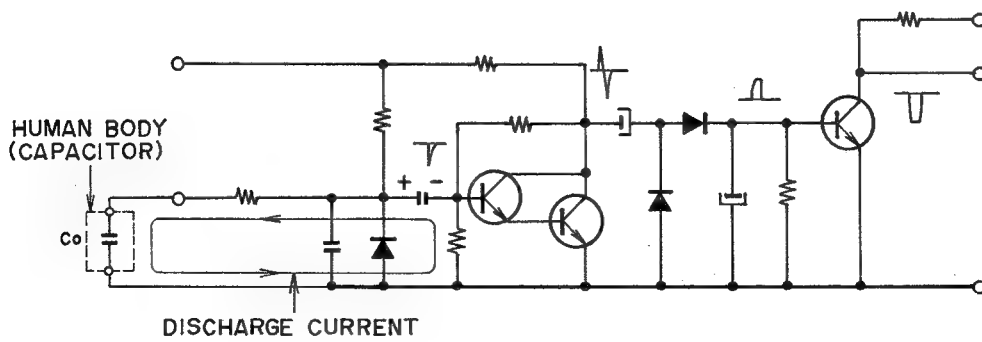

Fig. 6

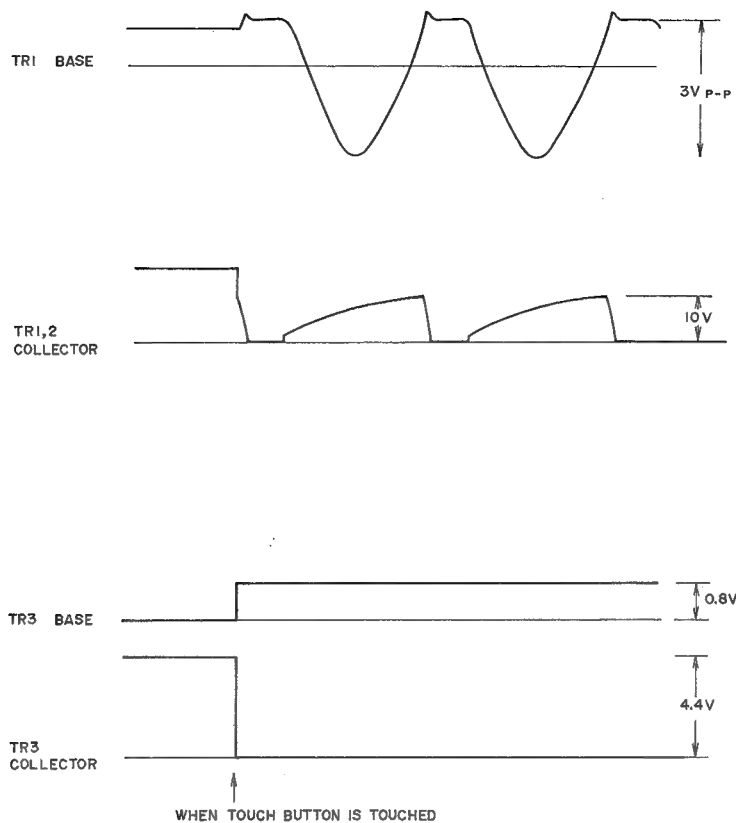

Fig. 7

2-1 CIRCUIT COMPONENT

As shown in Fig. 4, Touch Button System Circuit can be generally divided into a pulse generator circuit and rectifier circuit, and includes malfunction prevention capacitor, transistor protection resistor and diodes, etc.

As shown by the equivalent circuit in the diagram, last stage transistor TR3 performs the exact same function as a micro switch.

2-2 WHEN THE FINGER TOUCHES THE BUTTON ONLY (Refer to Figs. 5 and 7)

There is an inductance in our bodies from commercial power supply (50 Hz or 60 Hz) and as shown in Fig. 5, our bodies are equivalent to a kind of a signal source.

Accordingly, if there is a kind of a signal source, to touch a touch button is same as supplying a signal to it.

As shown in Fig. 5, when a button is touched with a finger, a signal is supplied to TR1 base.

When a signal is not supplied to TR1, base bias is supplied by R5 and R4. But because the electric potential is low, it does not function in full capacity. Also, TR2 is supplied with base bias from TR1 but is not in full operation. C3 is charged to an extent equivalent to TR2 collector voltage.

The signal supplied to TR1 base turns ON \oplus side of TR1 completely and turns OFF the \ominus side that

TR2 repeats ON and OFF also. When TR2 is turned ON, C3 is discharged through TR2 and D2; and when TR2 is turned OFF, C3 is charged and this pulse is rectified at D1 and charged at C4 to increase TR3 base electric potential. TR3 is thereby turned ON.

2-3 WHEN THE FINGER TOUCHES THE BUTTON WHILE ANOTHER FINGER OR HAND IS TOUCHING THE DECK CHASSIS (Refer to Fig. 6)

The above explains how a touch button operates with the human body as a signal source. It takes advantage of the fact that a human body can be used as a capacitor.

As shown in Fig. 6, when the button and chassis are both touched by the finger(s), it is the same as if a capacitor has been placed as shown in the circuit diagram.

Electric charge of C2 discharges to R1→Co→R4. As can be seen by the circuit, this discharging period is very short. During this short period of discharge, TR1 is turned OFF, TR2 collector electric potential increases, and C3 is charged. C4 is charged by the charging current of C3, and TR3 base electric potential increases. TR3 is thereby turned ON and functions in the same way as a micro switch.

VI. MECHANISM ADJUSTMENT

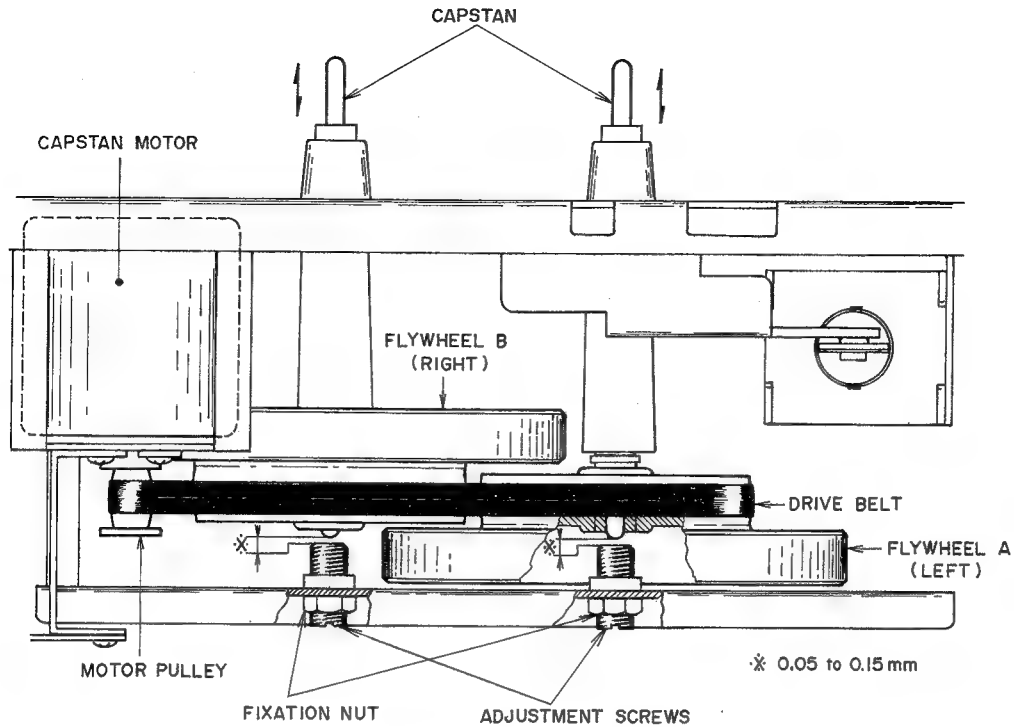
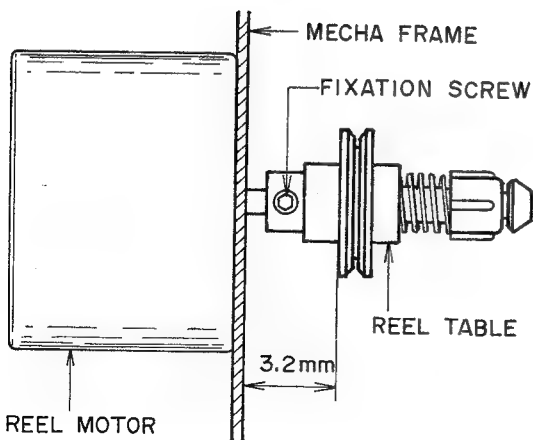

Fig. 8 Flywheel Thrust Loose Play Adjustment

1. FLYWHEEL THRUST LOOSE PLAY ADJUSTMENT (Refer to Fig. 8)

Adjust by turning flywheel thrust loose play adjustment screws to obtain a 0.05 to 0.15mm of loose play when the flywheel is moved as indicated by the arrow mark.

Tighten fixation nuts to maintain optimum adjusted condition. Paint lock the adjustment screws.



2. REEL TABLE INSTALLATION POSITION ADJUSTMENT (Refer to Fig. 9)

Adjust until a clearance of approximately 3.2mm is obtained between the mecha frame and the lower side of the reel table's pulley as shown in Fig. 9. Then, tighten the fixation screw firmly.

Fig. 9

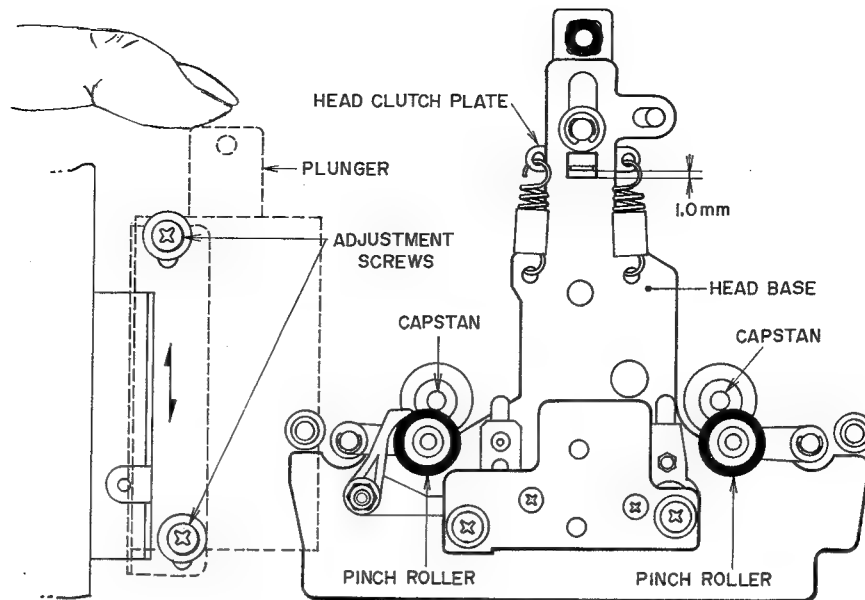

Fig. 10

3. PLAY PLUNGER INSTALLATION POSITION ADJUSTMENT (Refer to Fig. 10)

The clearance between the head base and head clutch plate when the plunger is moved as indicated in Fig. 10 at stop mode should be approximately 1.0mm. If not, adjust play plunger position with the adjustment screws in the direction as indicated by the arrow mark.

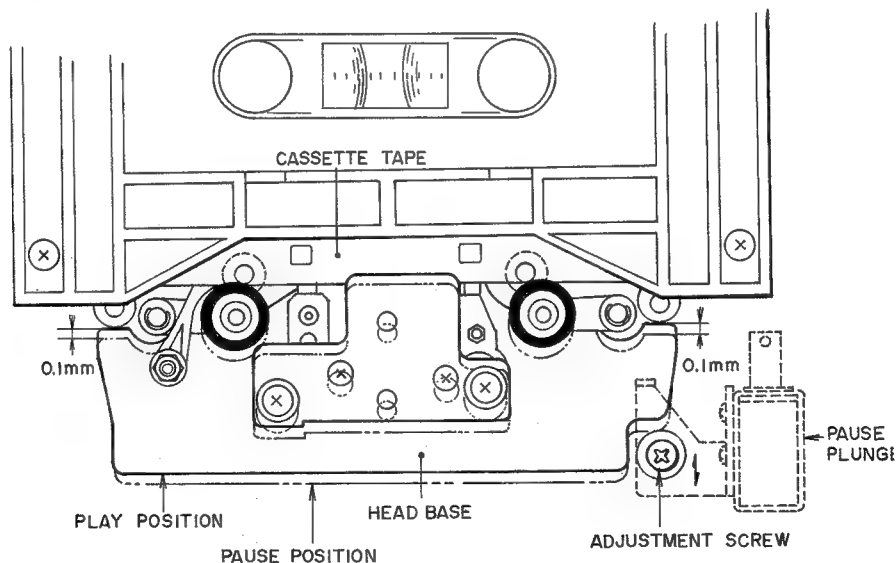

Fig. 11

4. PAUSE PLUNGER INSTALLATION POSITION ADJUSTMENT (Refer to Fig. 11)

With the tape loaded, the Pause Plunger Solenoid is not completely pulled if the head base does not lower at all when the mode is changed from PLAY to PAUSE. In order to allow Pause Plunger to function completely and still have the head not lowered too

much, the head base should lower only 0.1mm (lower only slightly) when the mode is changed from PLAY to PAUSE as shown in Fig. 11.

If you find that the plunger function is not complete, adjust by lowering the Pause Plunger Installation Position approximately 0.1mm using the adjustment screw.

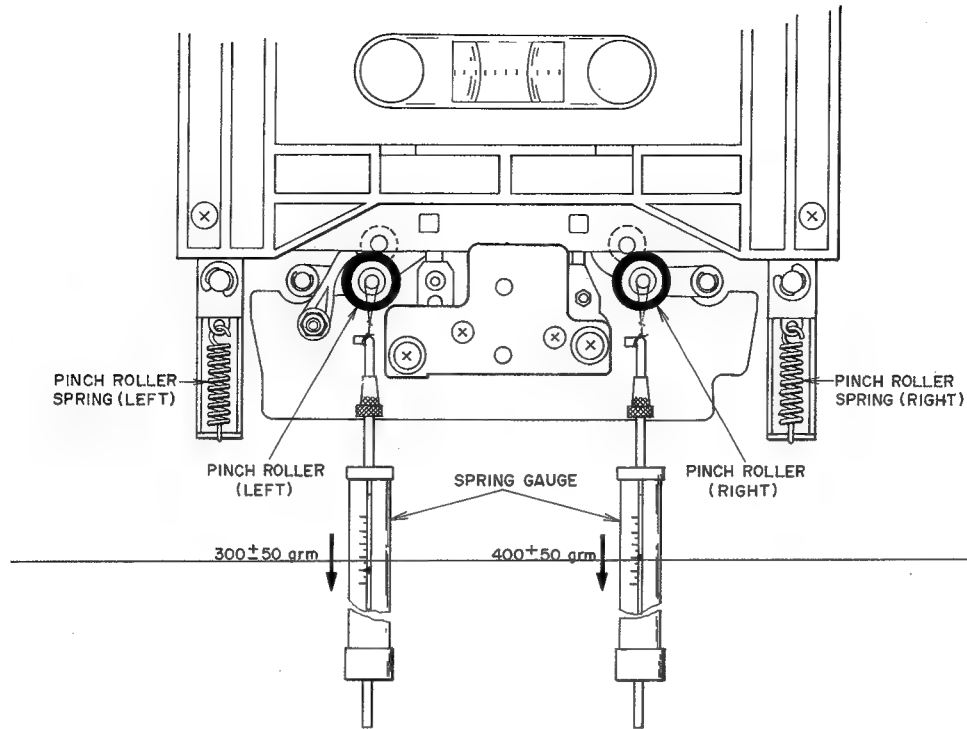

Fig. 12

5. PINCH ROLLER PRESSURE ADJUSTMENT (Refer to Fig. 12)

Load a cassette tape, set the recorder in the play mode, then pass a string around the pinch roller shaft and the spring gauge as shown in Fig. 12. Pull the spring gauge as indicated by the arrow mark in the figure until the pinch roller parts from the capstan. Then, gradually weaken the pulling force, and the spring gauge value when the pinch roller comes in contact with the capstan once again to start rotating. If the measurement value does not comply with the following values specified, replace the pinch roller spring.

Specified Pinch Roller Pressure:

Pinch Roller (Right) 400 ± 50 gm

Pinch Roller (Left) 300 ± 50 gm

6. TAKE-UP TORQUE AT VARIOUS MODES AND TORQUE MEASURING METHOD

Set a cassette torque meter on cassette base, and take a reading of the indication at each respective mode.

Playback mode: 33 to 55 gm-cm

Fast Forward mode: 80 to 120 gm-cm

Rewind mode: 80 to 120 gm-cm

7. LID PANEL POSITION ADJUSTMENT (Refer to Fig. 13)

In case the lid panel is not level with the front panel, adjust by shifting the eject guide as indicated by the arrow mark in Fig. 13. If the upper part of the lid panel is tilted inward, move the eject guide upward, and if tilted outward, move the eject guide downwards.

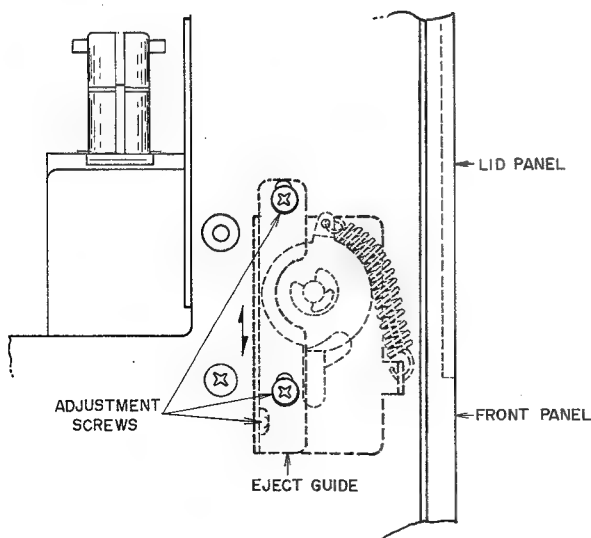

Fig. 13 Left Side of the Deck

VII. HEAD ADJUSTMENT

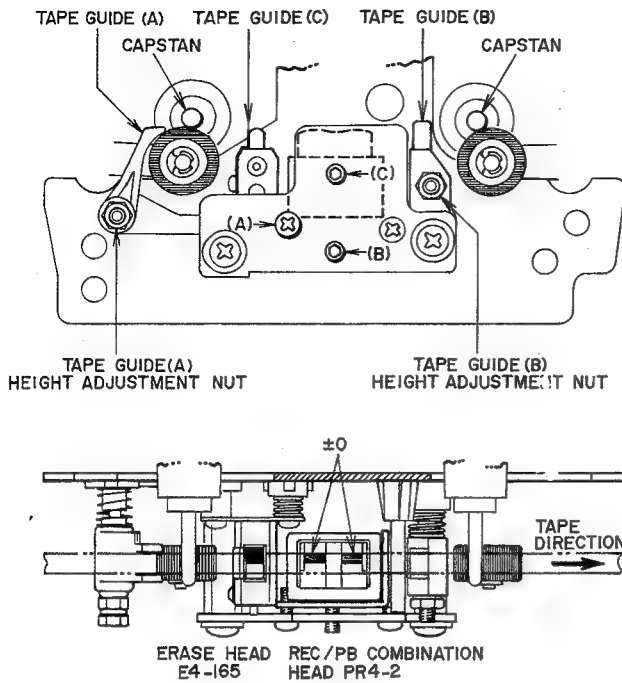

Fig. 14

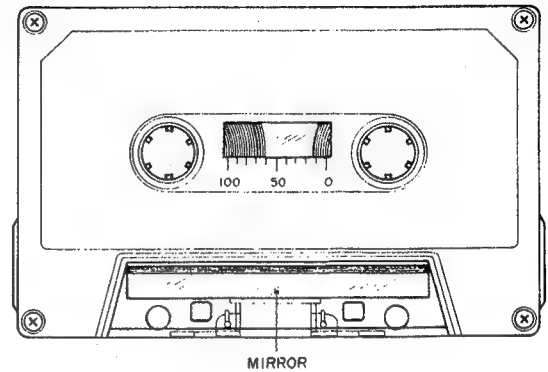

Fig. 15

1. TAPE GUIDE HEIGHT ADJUSTMENT (Refer to Figs. 14, 15)

- 1) When using an ordinary cassette, the tape guides and heads, etc. are not visible. As shown in Fig. 15 use a cassette tape from which part of the cassette case has been cut out and a mirror installed for easy visibility of the head area when making tape guide height adjustment.
- 2) At playback mode, using the erase head guide (C) shown in Fig. 14 as standard for height, adjust tape guide (A) and tape guide (B) height with tape guide height adjustment nuts so that the tape runs smoothly and does not catch on the tape guides.

2. HEIGHT ADJUSTMENT OF RECORDING/ PLAYBACK COMBINATION HEAD (Refer to Fig. 14)

- 1) Utilize the cassette tape used in Tape Guide Height Adjustment above, and playback the leader tape part of cassette tape.
- 2) As shown in Fig. 14 adjust head height with screws (A), (B) and (C) until the upper edge of the tape is the same height as the upper edge of the left channel REC/PB Combination head core.

3. AZIMUTH ALIGNMENT ADJUSTMENT OF RECORDING/PLAYBACK COMBINATION HEAD (Refer to Fig. 14)

- 1) The cores of recording and playback heads are mounted in a single head holder to form the recording/playback combination head otherwise known as the New GX Head. Both recording and playback head cores move when azimuth alignment is adjusted. To obtain optimum playback head core azimuth alignment, follow the instructions 2) – 5) carefully.
- 2) Playback a 10 kHz azimuth alignment adjustment test tape and adjust the adjustment screw (A) until the output level of both channels are at maximum.
- 3) Invert cassette and see whether there is an output level difference from the above. If there is a difference, repeat (2) and readjust.
- 4) Record a 10 kHz, -20 VU signal from the audio frequency oscillator.
- 5) Rewind and check for any fluctuation in the output level at playback.

- NOTES: 1. Be sure to clean the heads prior to head adjustment.
2. Be careful not to use a magnetized driver or other magnetized tools in the vicinity of the heads.
 3. Be sure to demagnetize the heads with a Head Demagnetizer before and after head adjustment.
 4. When a mirror installed cassette test tape as shown in Fig. 15 is required, it can be ordered from AKAI Electric Co.

VIII. AMPLIFIER ADJUSTMENT

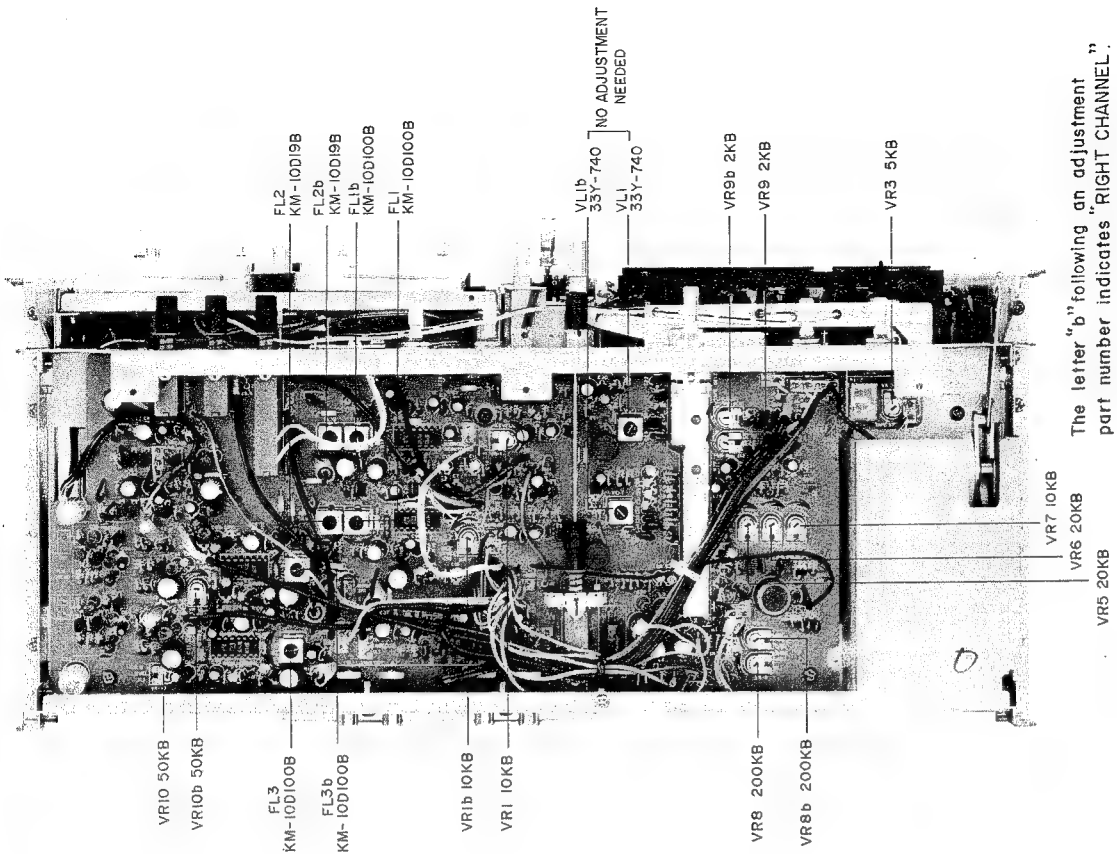

The letter "b" following an adjustment part number indicates "RIGHT CHANNEL".

Fig. 16 Amp P.C Board CI-5202A

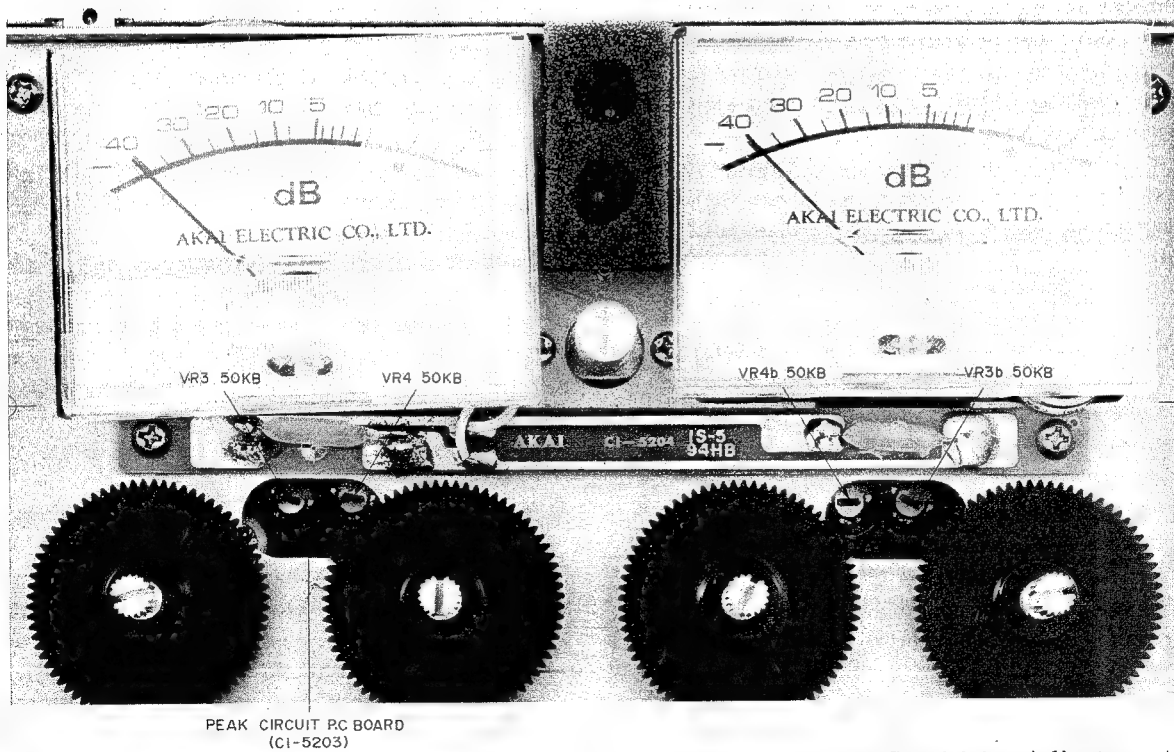

PEAK CIRCUIT RC BOARD (CI-5203)

Fig. 17 Meter Sensitivity Adjustment

MODEL GXC-570D II

Step	Adjustment Item	Test Tape Supply Signal	Mode	Adjustment Point	Result	Remarks
1	Tape Speed Adjustment	1,000 Hz Test Tape	PLAY	VR3 5 kB (CI-5202A)	1,000 Hz $\pm 2\%$	Set Monitor Switch to "TAPE"
2	Playback Level Adjustment	333 Hz 0 VU Test Tape	PLAY	VR10 50 kB (CI-5202A)	-5.5 dBm ± 0.5 dBm	
3	VU Meter Sensitivity Adjustment	1,000 Hz, 0 VU from an Oscillator	STOP	VR3 50 kB (CI-5203)	0 VU Indication	Set Monitor Switch to "SOURCE". Set Meter Selector Switch to "VU".
4	Peak Meter Indication Adjustment	1,000 Hz, 0 VU from an Oscillator	STOP	VR4 50 kB (CI-5203)	-8 VU Indication	Set Meter Selector Switch to "PEAK".
5	PB Equalizer Adjustment	10 kHz Test Tape	PLAY	VR9 2 kB (CI-5202A)	-20 dBm	Set Monitor Switch to "TAPE".
6	CrO ₂ Position Frequency Response Adjustment	CrO ₂ blank tape, 1,000 Hz, 10,000 Hz, -20 VU recording	REC/PLAY	VR8 200 kB (CI-5202A)	1,000 Hz to 10,000 Hz flat response	Set Tape Selector Switch to "CrO ₂ ".
7	LN Position Frequency Response Adjustment	LN blank tape, 1,000 Hz, 10,000 Hz, -20VU recording	REC/PLAY	VR7 10 kB (CI-5202A)	1,000 Hz to 10,000 Hz flat response	Set Tape Selector Switch to "LN". (Refer to NOTE 5)
8	LH Position Frequency Response Adjustment	LH blank tape, 1,000 Hz, 10,000 Hz, -20 VU recording	REC/PLAY	VR6 20 kB (CI-5202A)	1,000 Hz to 10,000 Hz flat response	Set Tape Selector Switch to "LH". (Refer to NOTE 5)
9	Fe-Cr Position Frequency Response Adjustment	Fe-Cr blank tape 1,000 Hz 10,000 Hz, -20 VU recording	REC/PLAY	VR5 20 kB (CI-5202A)	1,000 Hz to 10,000 Hz flat response	Set Tape Selector Switch to "Fe-Cr". (Refer to NOTE 5)
10	Recording Level Adjustment	LN blank tape, 1,000 Hz 0 VU Recording	REC/PLAY	VR1 10 kB (CI-5202A)	-5.5 dBm ± 0.5 dBm	
11	Rec Amp Bias Leak Adjustment	100 kHz from an oscillator	REC	FL1 KM10D 100B (CI-5202A)	Minimum AC Voltmeter indication	Set Monitor Switch to "SOURCE". (Refer to NOTE 8).
12	19 kHz Filter Adjustment	19 kHz from an oscillator	REC	FL2 KM10D 19B (CI-5202A)	Minimum AC Voltmeter indication	Set MPX Filter Switch to "ON". (Refer to NOTE 8)
13	PB Amp Bias Leak Adjustment		REC	FL3 KM10D 100B (CI-5202A)	Minimum AC Voltmeter indication	Set Monitor Switch "TAPE". Set Tape Selector Switch to "CrO ₂ ".

Chart-2

- NOTES:
1. Set Pitch Control and Rec Calibration Volumes to center position.
 2. Except for Steps #6, 8, 9 and 13, set Tape Selector to LN position.
 3. Set Dolby N.R. switch, Cal. Tone Switch and Limiter Switch to OFF position.
 4. Except for Step 12, set MPX Filter switch to OFF position.
 5. If a flat characteristic cannot be obtained from 1,000 Hz to 10,000 Hz at LN, LH, or Fe-Cr positions, fine adjust at VR7 (LN), VR6 (LH) or VR5 (Fe-Cr) respectively.
 6. Because each of these adjustments are vital to perfect Dolby N.R. circuit operation, be sure that they are carried out with as little error as possible.
 7. Use the following cassette measuring tape:
 - LN Tape: Fuji FL C-60
 - LH Tape: Maxell UD C-60
 - CrO₂ Tape: TDK SA C-60
 - Fe-Cr Tape: SONY Duad C-60
 8. Unless the core is moved intentionally this adjustment is not necessary.
 9. No adjustment is required for the adjustment core VL1 (33Y-740) of the recording equalizer. Do not touch it.

IX. DC RESISTANCE OF VARIOUS COLILS

Parts	Designation	DC Resistance
Recording/Playback Combination Head	PR4-2	REC: 22 ohms ±5% PB: 250 ohms ±5%
Erase Head	E4-165	2.5 ohms
Play Plunger	TDS-12E	120 ohms ±10%
Pause Plunger	P-120F	540 ohms ±10%
Relay	MZ-24HG	1,280 ±130 ohms
Relay L Type	L24	1,600 ±160 ohms

Chart-3

X. CLASSIFICATION OF VARIOUS P.C BOARDS

1. RELATION OF P.C BOARD TITLE AND IDENTIFICATION NUMBER

P.C Board Title	P.C Board Number
Amp P.C Board	CI-5202A
Peak Lamp P.C Board	CI-5202B
LED P.C Board	CI-5202C
Peak Circuit P.C Board	CI-5203
Housing Lamp P.C Board	CI-5204
Monitor SW. P.C Board	CI-5205
Power Supply P.C Board	CI-5206
Power Supply SW. P.C Board (A)	CI-5207
Power Supply SW. P.C Board (B)	CI-5208
Sys. Con P.C Board	CI-5209A
Remote Control P.C Board	CI-5209B
AS P.C Board	CI-5209C
Tough Senser P.C Board	CI-5210C
Door Open P.C Board	CI-5211
Lamp P.C Board	CI-5237
Noise Filter P.C Board	CB-2027

Chart-4

2. COMPOSITION OF VARIOUS P.C BOARDS

1) AMP P.C BOARD CI-5202A and LED P.C BOARD CI-5202C

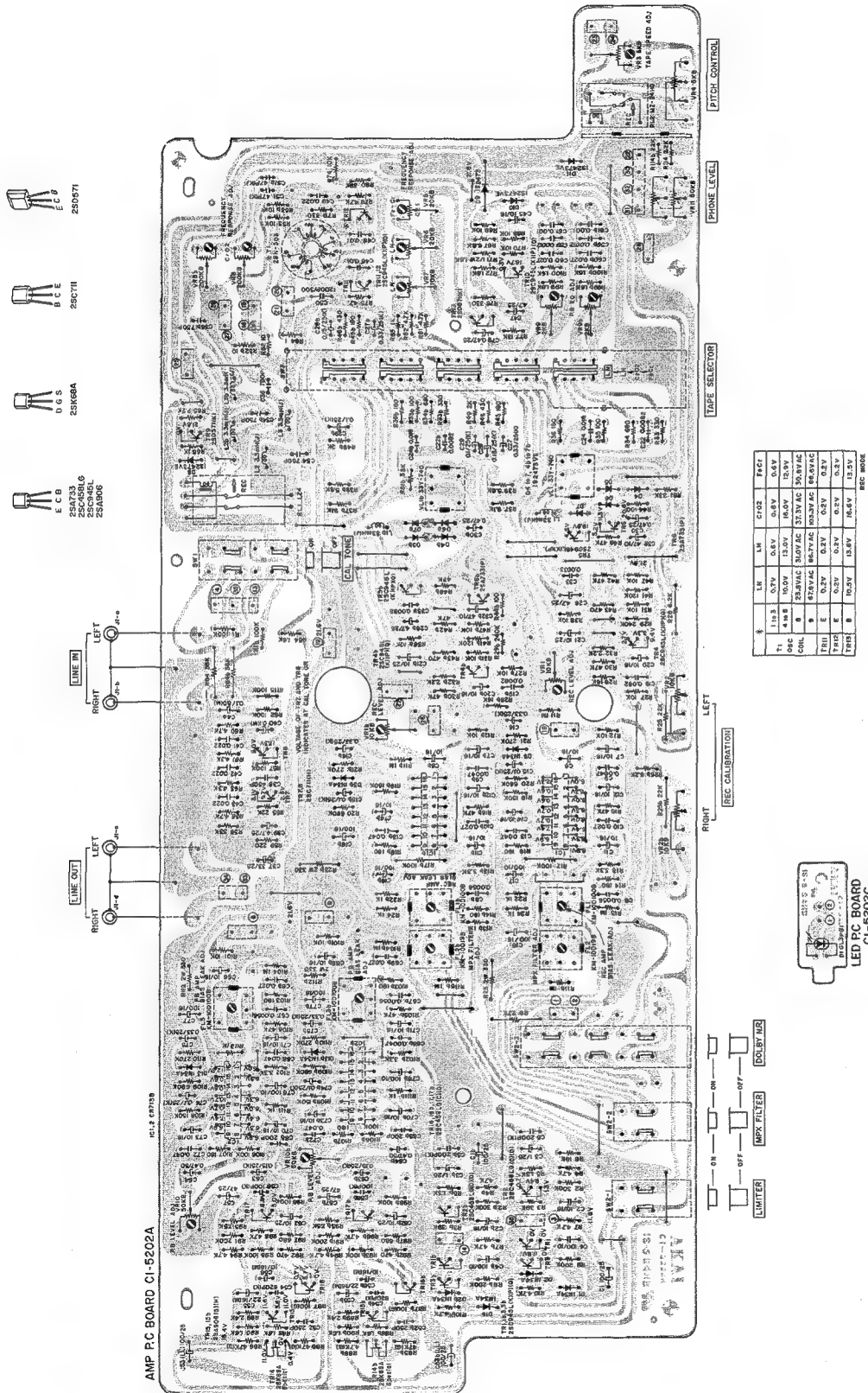

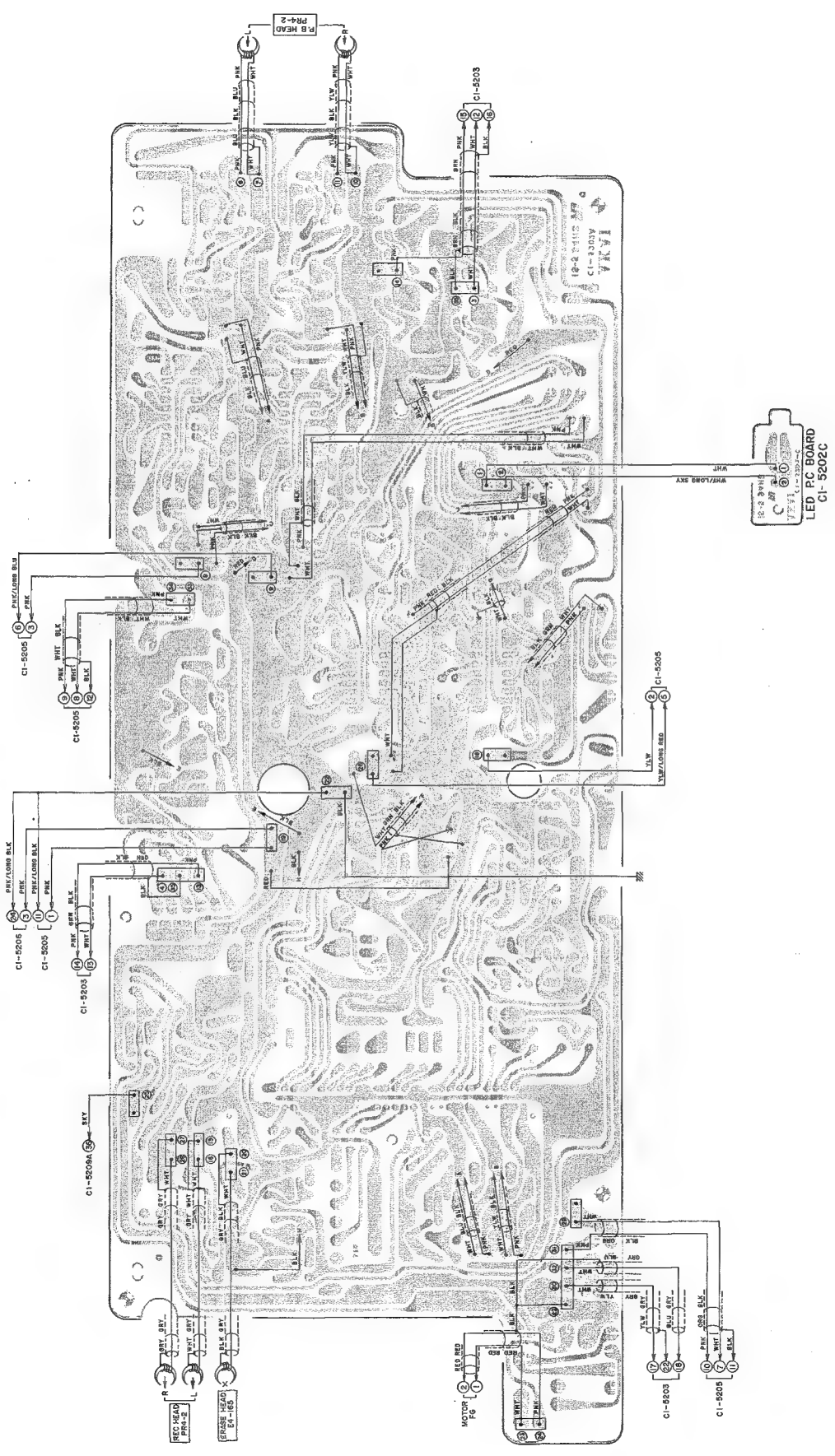

2) SYS. CON P.C BOARD CI-5209A, REMOTE CONTROL P.C BOARD CI-5209B and TOUCH SENSOR P.C BOARD CI-5210

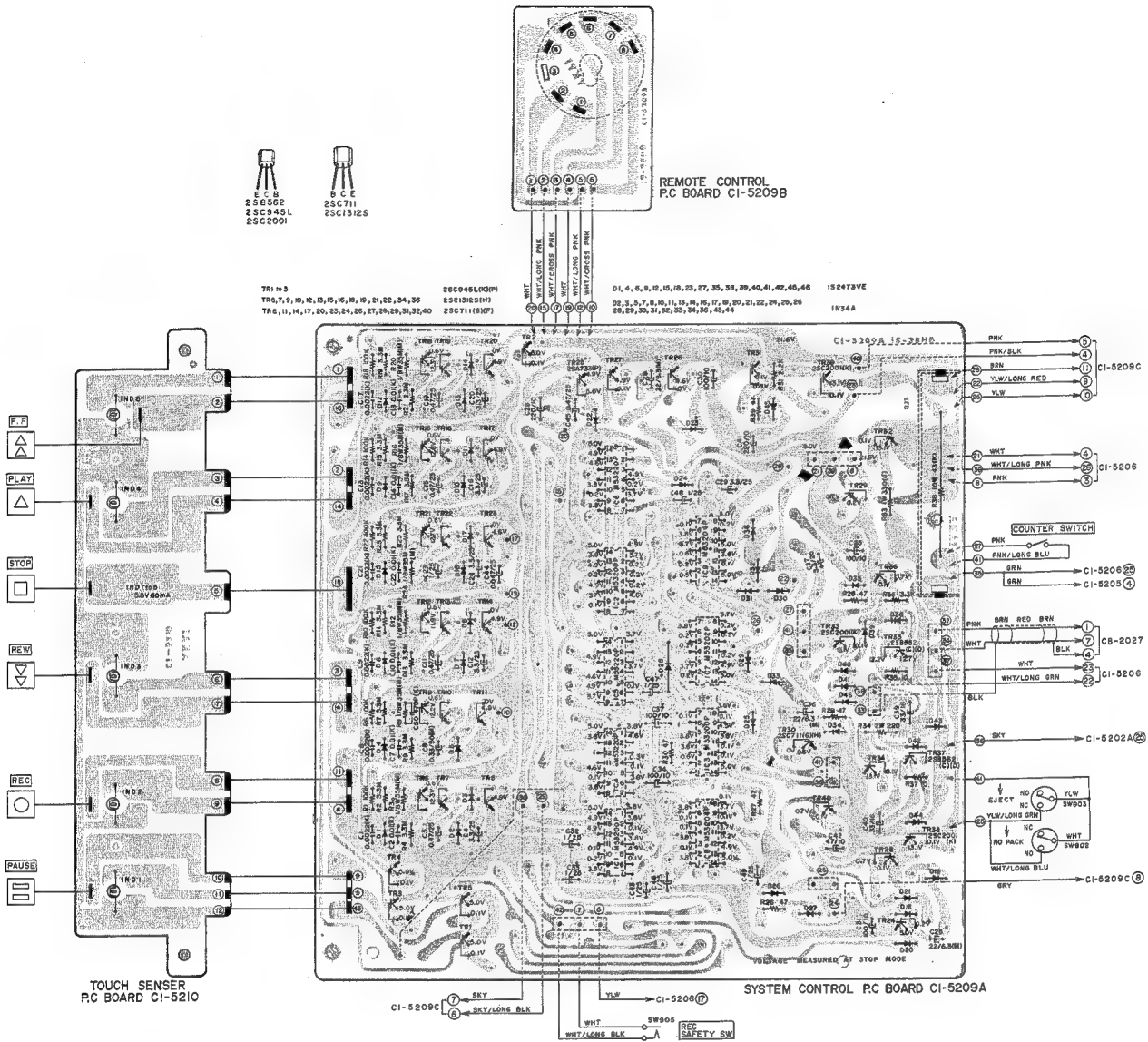

3) PEAK CIRCUIT P.C BOARD CI-5203, PEAK LAMP P.C BOARD CI-5202B, HOUSING LAMP P.C BOARD CI-5204 and LAMP P.C BOARD CI-5237

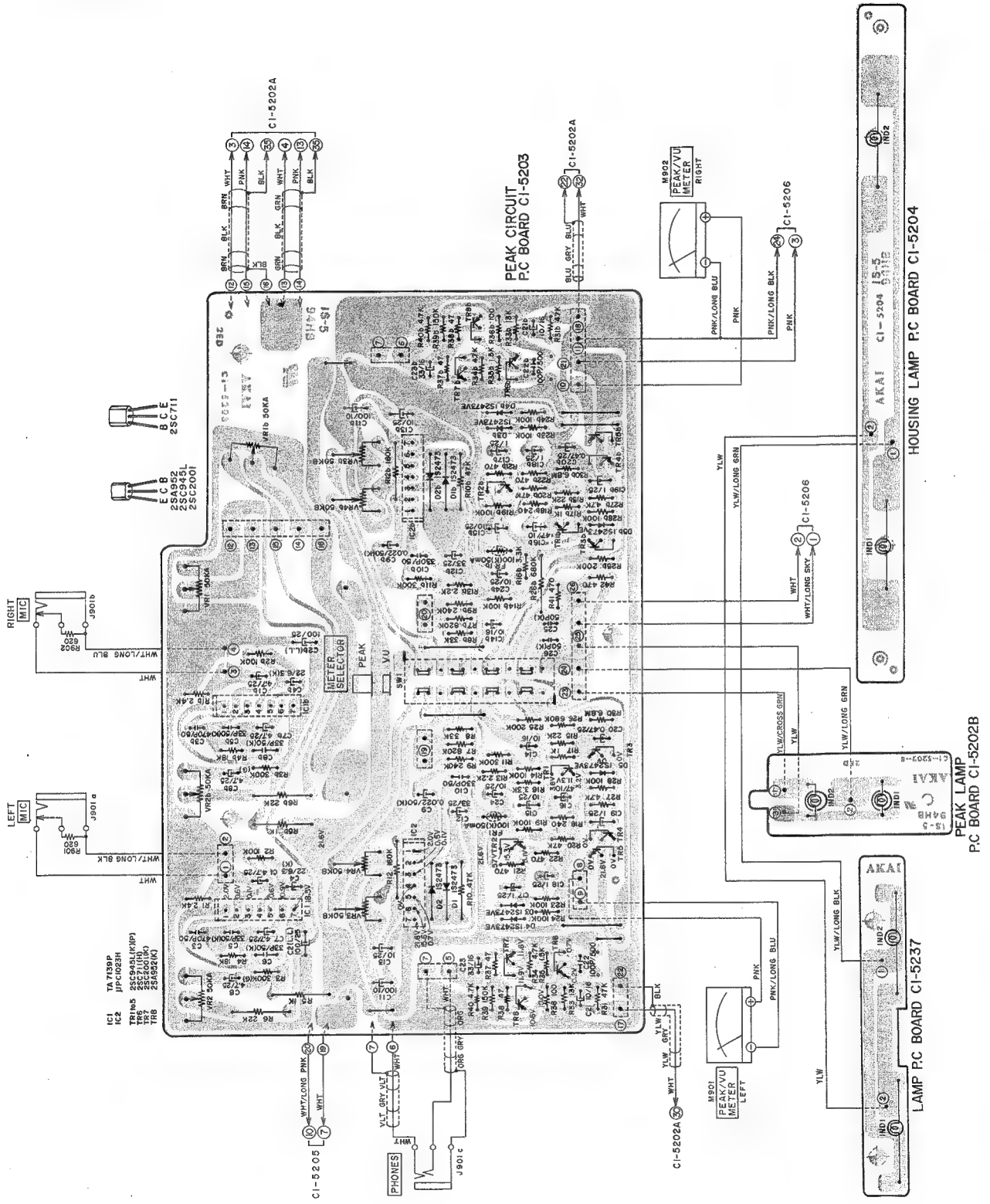

4) MONITOR SW. P.C BOARD CI-5205

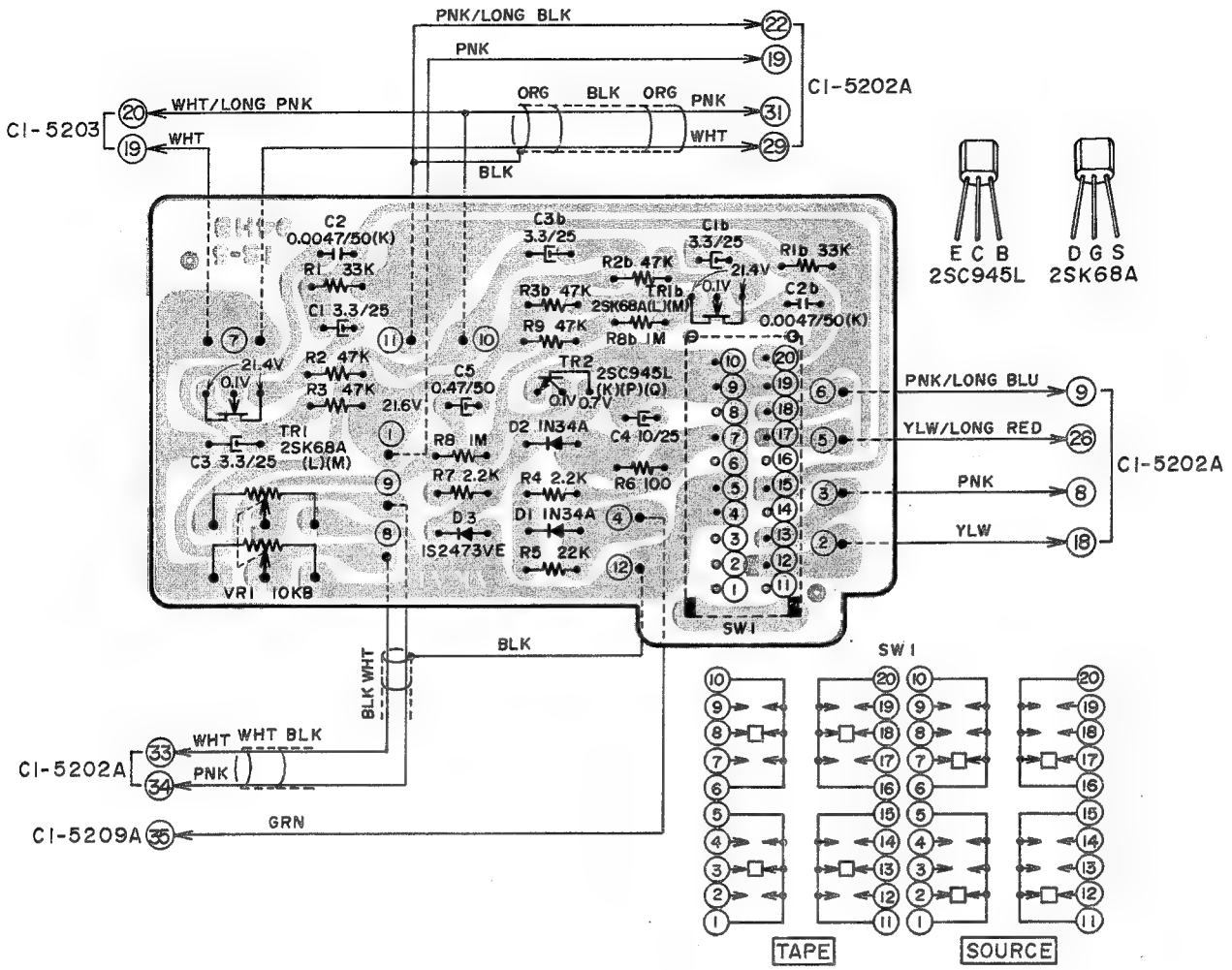

5) DOOR OPEN P.C BOARD CI-5211

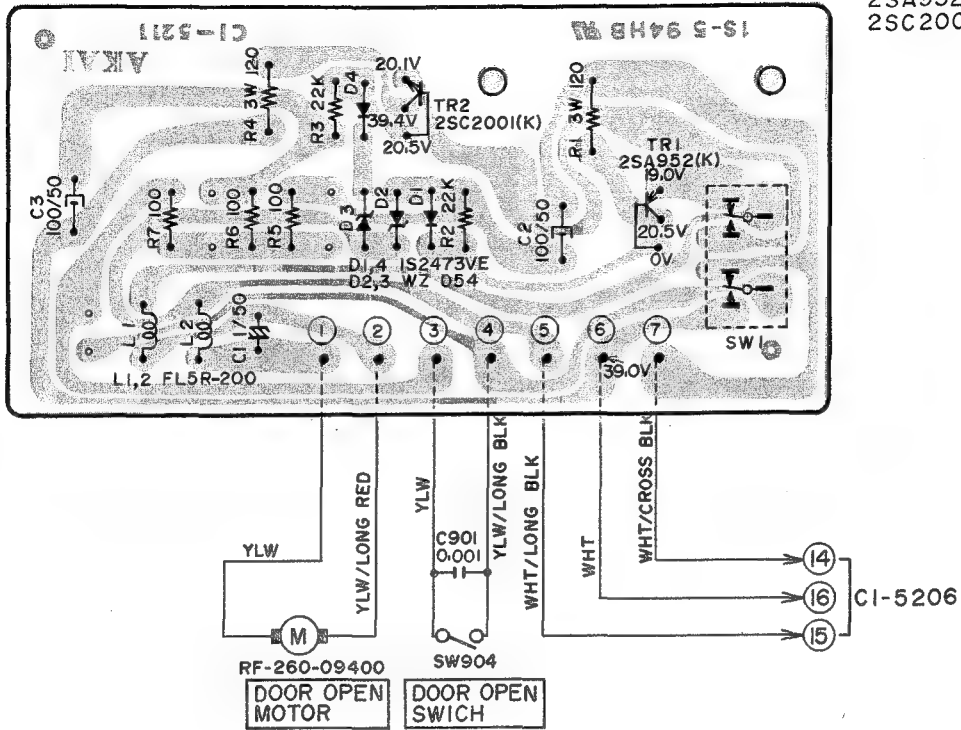
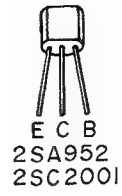

6) AS P.C BOARD CI-5209C

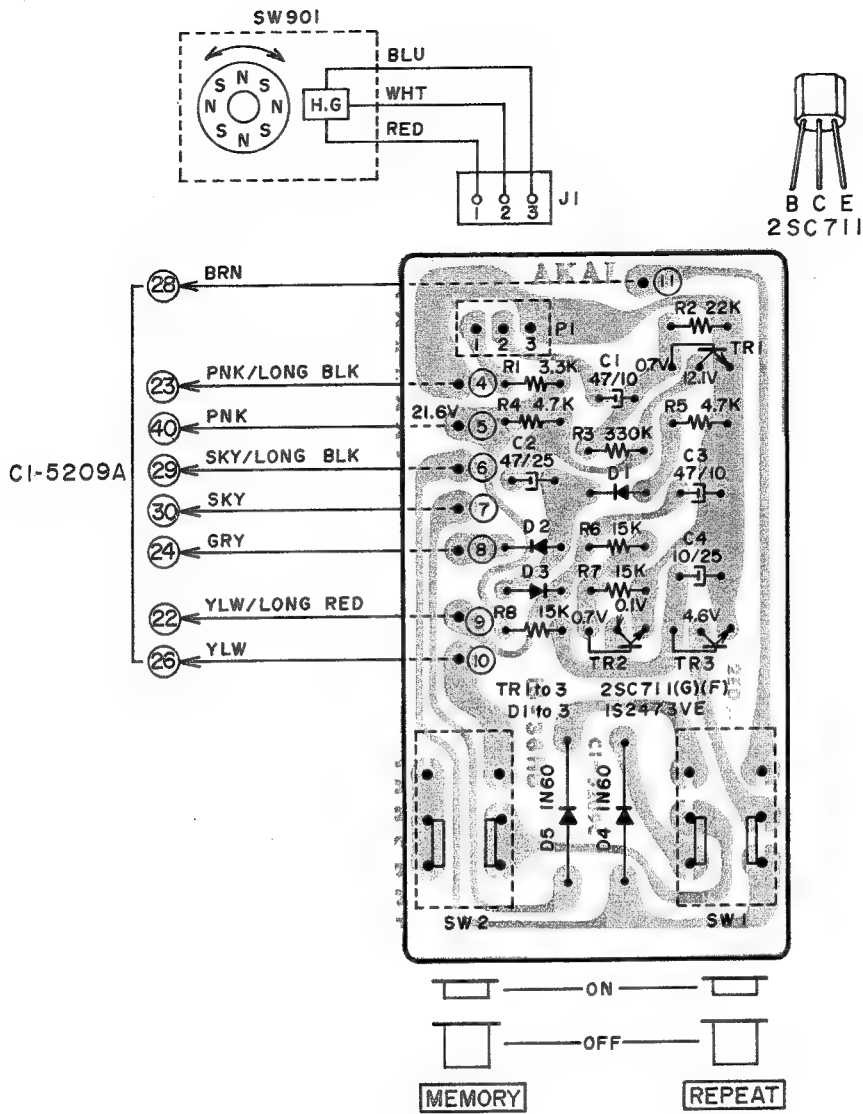

7) POWER SUPPLY P.C BOARD CI-5206 and POWER SUPPLY SW. P.C BOARD (A) CI-5207

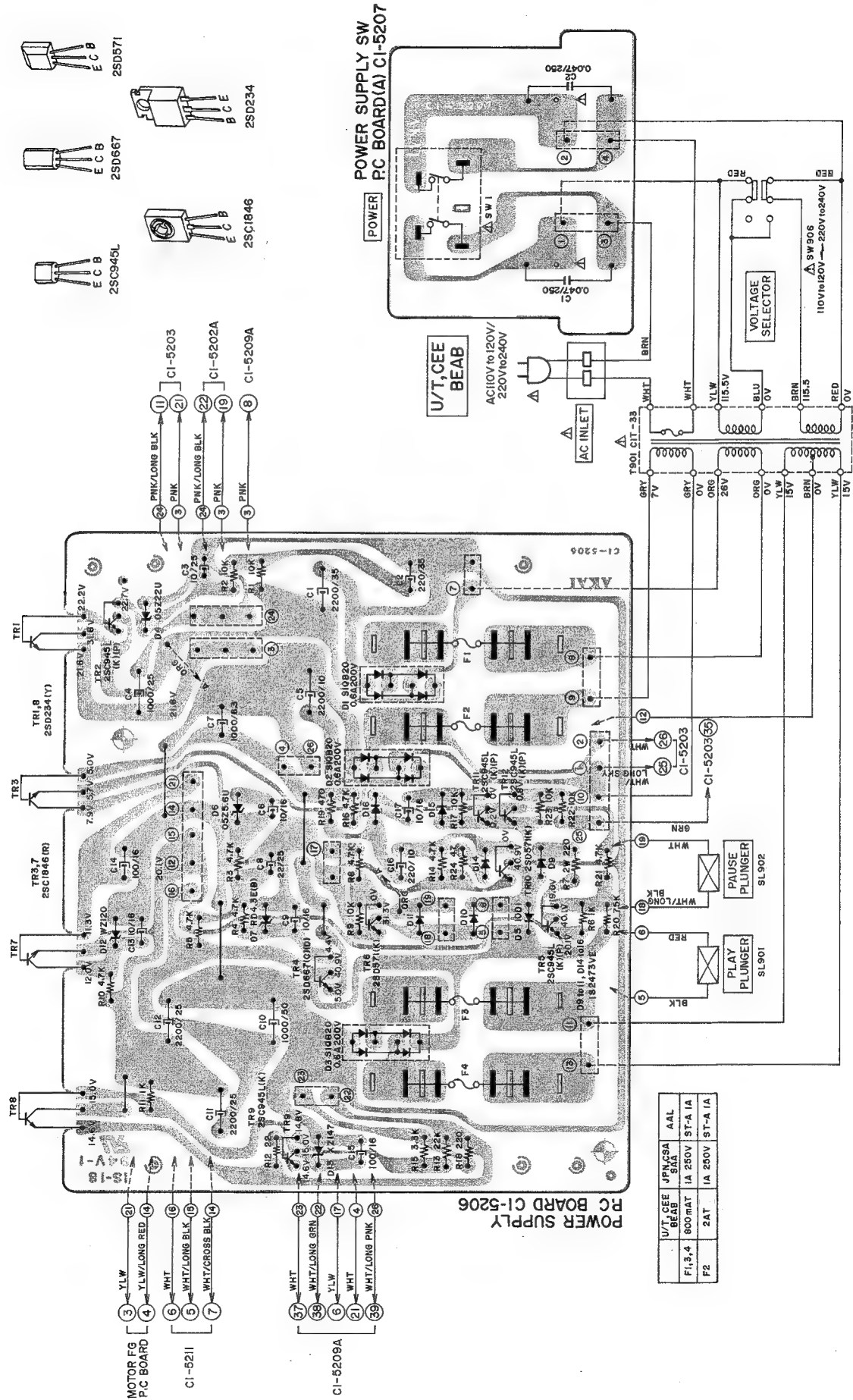

8) POWER SUPPLY SW. P.C BOARD (B) CI-5208

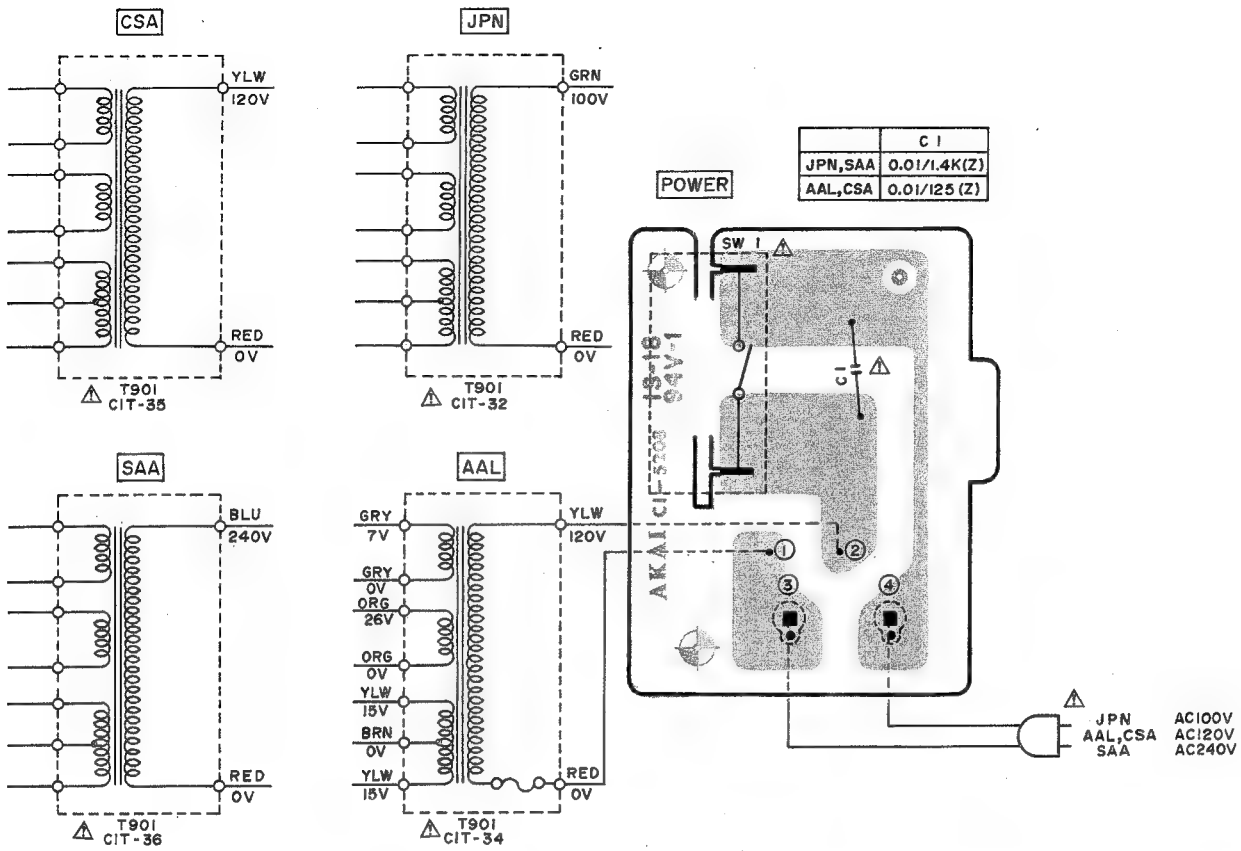

WARNING: Δ INDICATES SAFETY CRITICAL COMPONENTS. FOR CONTINUED SAFETY, REPLACE SAFETY CRITICAL COMPONENTS ONLY WITH MANUFACTURER'S RECOMMENDED PARTS

AVERTISSEMENT: Δ IL INDIQU LES COMPOSANTS CRITIQUES DE SÛRETÉ. POUR MAINTENIR LE DEGRE DE SECURITE DE L'APPAREIL NE REMPLACER LES COMPOSANTS DONT LE FONCTIONNEMENT EST CRITIQUE POUR LA SECURITE QUE PAR DES PIECES RECOMMANDEES PAR LE FABRICANT

9) NOISE FILTER P.C BOARD CB-2027

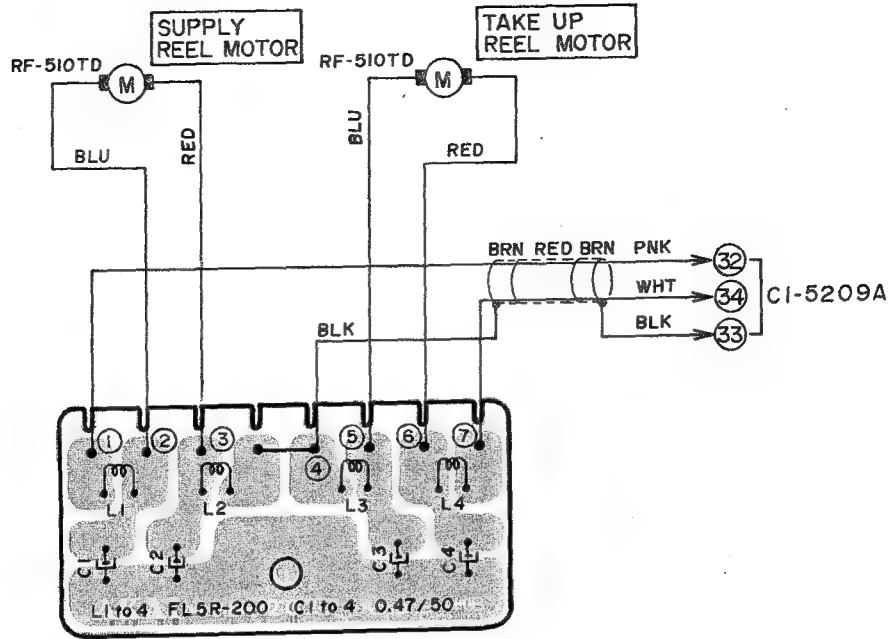

SECTION 2

PARTS LIST

TABLE OF CONTENTS

1. RECOMMENDED SPARE PARTS LIST	42
2. HEAD BASE BLOCK	44
3. REEL TABLE BLOCK	45
4. CASSETTE HOLDER BLOCK	46
5. MECHA FRAME BLOCK (1)	47
6. MECHA FRAME BLOCK (2)	48
7. P.C BOARDS	50
(1) AMP P.C BOARD (CI-5202A) BLOCK	50
(2) POWER SUPPLY P.C BOARD (CI-5206) BLOCK	51
(3) SYS. CON (CI-5209A/B/C) BLOCK	51
(4) PEAK CIRCUIT P.C BOARD (CI-5203) BLOCK	52
(5) MONITOR SW. P.C BOARD (CI-5205) BLOCK	53
(6) DOOR OPEN P.C BOARD (CI-5211) BLOCK	53
8. ASSEMBLY BLOCK	54
9. TOUCH BUTTON BLOCK	56
10. DOOR OPEN BLOCK	58
11. FINAL ASSEMBLY BLOCK	60
12. LIST OF INTERCHANGEABLE SEMICONDUCTORS	61
INDEX	63

Resistor and Capacitor which is not listed in this parts list, please refer to COMMON LIST FOR SERVICE PARTS.

HOW TO USE THIS PARTS LIST

1. This parts list is compiled by various individual blocks based on assembly process.
2. When ordering parts, please describe parts number, serial number, and model number in detail.
3. How to read list.

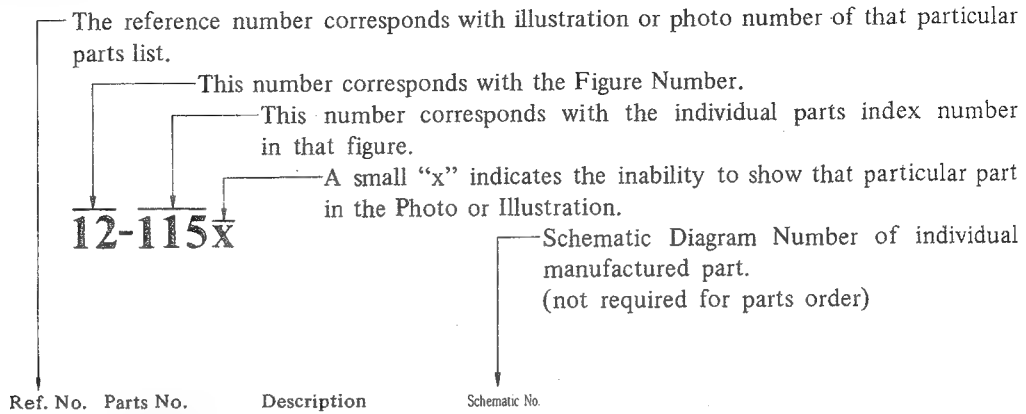

4. The symbol numbers shown on the P.C. Board list can be matched with the Composite Views of components of the Schematic Diagram or Service Manual.
5. The indications of Resistors and Capacitors in the photos of P.C. Board are being eliminated.
6. The shape of the parts and parts name, etc. can be confirmed by comparing them with the parts shown on the Electrical Parts Table of P.C. Board.
7. Both the kind of part and installation position can be determined by the Parts Number. To determine where a parts number is listed, utilize Parts Index at end of Parts List.
It is necessary first of all to find the Parts Number. This can be accomplished by using the Reference Number listed at right of parts number in the Parts Index. (meaning of ref. no. outlined in Item 3 above).
8. Utilize separate "Price List for Parts" to determine unit price. The most simple method of finding parts Price is to utilize the reference number.

CAUTION:

1. When placing an order for parts, be sure to list the parts no. model no., and description. There are instances in which if any of this information is omitted, parts cannot be shipped or the wrong parts will be delivered.
2. Please be careful not to make a mistake in the parts no. If the parts no. is in error, a part different from the one ordered may be delivered.
3. Because parts number and parts unit supply in the Preliminary Service Manual (Basic Parts List) may be partially changed, please use this parts list for all future reference.

WARNING: Δ INDICATES SAFETY CRITICAL COMPONENTS. FOR CONTINUED SAFETY, REPLACE SAFETY CRITICAL COMPONENTS ONLY WITH MANUFACTURER'S RECOMMENDED PARTS.

AVERTISSEMENT: Δ IL INDIQU LES COMPOSANTS CRITIQUES DE SURETE. POUR MAINTENIR LE DEGRE DE SECURITE DE L'APPAREIL NE REMPLACER LES COMPOSANTS DONT LE FONCTIONNEMENT EST CRITIQUE POUR LA SECURITE QUE PAR DES PIECES RECOMMANDEES PAR LE FABRICANT.

AC INLET SYSTEM

This model is equipped with an AC INLET SYSTEM. Please refer to the AC INLET SYSTEM CHART below for the specific type. By the AC INLET SYSTEM, AC (mains) cord can be connected to and disconnected from the model because the model is provided with socket exclusively for AC (mains) cord on its main body. Please note, however, that certain models are not equipped with this system and has a built-in AC (mains) cord as before.

AC INLET SYSTEM CHART

CLASS I

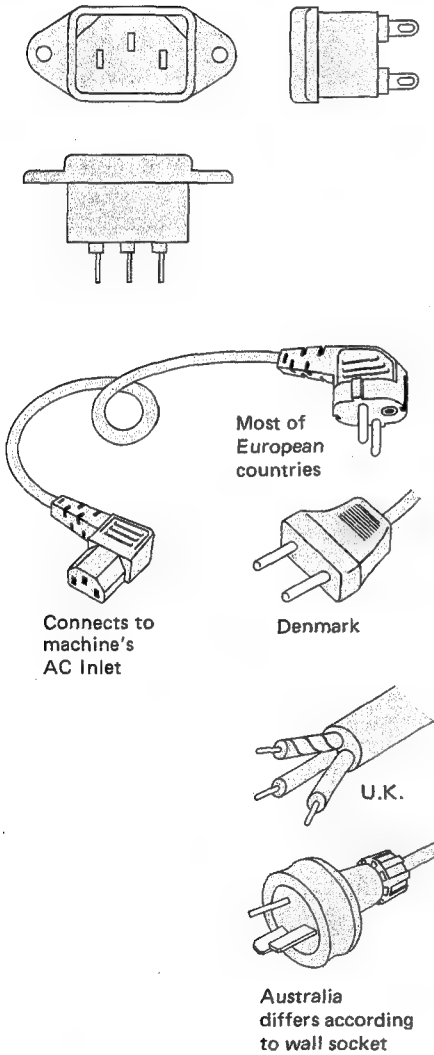

Picture 1
AC INLET
to be
installed
on machines

CLASS II

⊠ This mark indicating double insulation will be attached to machine's rear panel

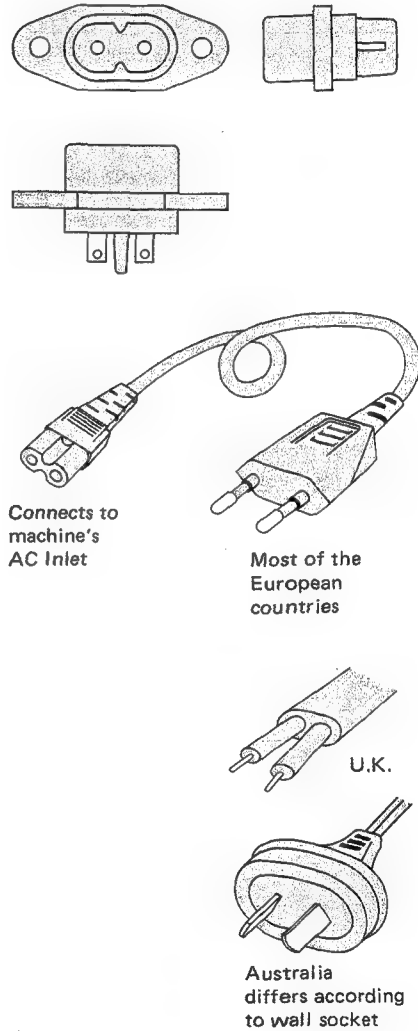

Picture 2
AC (mains)
cord

Parts List for AC (mains) Cord Set

Standard		Description	Type of AC Inlet	Parts No.
Class I	CEE	Cord Set CEE (3 cores)	3P	EW302993
	BEAB	Cord Set BEAB (3 cores)	3P	EW302994
	SAA	Cord Set SAA (3 cores)	3P	EW302996
	U/T	Cord Set U/T (3 cores)	3P	EW302646
Class II	CEE	Cord Set CEE (2 cores)	2P	EW638144
	BEAB	Cord Set BEAB (2 cores)	2P	EW302995
	SAA	Cord Set SAA (2 cores)	2P	EW302991
	U/T	Cord Set U/T (2 cores)	2P	EW302899

1. RECOMMENDED SPARE PARTS LIST

Because, if the parts listed below are on hand, almost any repair can be accomplished, we suggest that you stock these Recommended Spare Parts Items.

Parts No.	Description	Note
BA302529	Amp P.C Board Comp. CI-5202A	
BA302555	Door Open P.C Board Comp. CI-5211	
BA302080	Peak Circuit P.C Board Comp. CI-5203	
BA302082	Monitor SW. P.C Board Comp. CI-5205	
BA302077	AS P.C Board Comp. CI-5209C	
BA301344	Power Supply P.C Board Comp. CI-5206	U/T, CEE, BEAB
BA301343	Power Supply P.C Board Comp. CI-5206	CSA, AAL, SAA, JPN
BA304547	Sys. Con P.C Board Comp. CI-5209A	
BA302536	Noise Filter P.C Board Comp. CB-2027	Same as GXC-760D
BH302650	Head Base Block Comp.	
BM302656	Capstan Motor Block Comp.	
BM302503	Capstan Motor MHK-8B2RSD	
BM302507	Reel Motor RF-510TD	
BM692550	Motor RF-260-09400	
BT302548	△ Power Trans. CIT-33	U/T, CEE, BEAB
BT302551	△ Power Trans. CIT-35	CSA
BT302549	△ Power Trans. CIT-34	AAL
BT302047	△ Power Trans. CIT-36	SAA
BT302545	△ Power Trans. CIT-32	JPN
ED224526	Silicon Diode 10D01	
ED302643	Zener Diode RD-4. 3E (B)	
ED303155	Zener Diode 05Z-5.6U	
ED510772	Zener Diode WZ-120	
ED304243	Zener Diode XZ-147	
ED303156	Zener Diode 05Z-22U	
ED303034	Zener Diode WZ-054	
ED283138	LED GL-3PG1	
EI301463	Dolby IC CR-713B	
EI430661	IC M53200P	
EI633960	IC M53202P	
EI573840	IC M53204P	
EI592198	IC M53220P	
EI669666	IC MPC1023H	
EI302623	IC TA-7139P	
EM302355	VU Meter KL-250L-12	JPN
EM303428	VU Meter KL-250L-11	Other Models
EO301466	OSC. Coil 28N-503	
EP302421	Plunger Solenoid 1254TLT	
EP302445	Plunger Solenoid P-120F	
EP491446	Relay MZ-24HG	Same as GXC-570D

Parts No.	Description	Note
ES301510	△ Slide SW. (B)	U/T, CEE, BEAB
ES665807	△ Push SW. SDG-5P 5A/80A 250V	U/T, CEE, BEAB
ES280258	△ Push SW. SDV1P TV-5	AAL
ES293703	△ Push SW. SDV1P TV-5	CSA, SAA, JPN
ET539133	Transistor 2SA733 (P)	
ET302456	Transistor 2SA906 (G) (H)	
ET302539	Transistor 2SA952 (K)	
ET304446	Transistor 2SB562 (C) (D)	
ET429748	Transistor 2SC711 (H)	
ET242684	Transistor 2SC1312S (H)	
ET302502	Transistor 2SC2001 (K)	
ET391768	Transistor 2SC458LG (C) (D)	
ET632204	Transistor 2SC945L (K) (P) (Q)	
ET302635	Transistor 2SC1846 (Q)	
ET208012	Transistor 2SD571 (K)	
ET303895	Transistor 2SD667 (C) (D)	
ET242370	Transistor 2SD234 (Y)	
ET304169	FET 2SK68 (L) (M)	
ET302466	FET 2SK68A (Special)	
EV520806	Semi-fixed/Vol. V8K4-1 10 kB	
EV464207	Semi-fixed/Vol. V8K4-1 5 kB	
EV522797	Semi-fixed/Vol. V8K4-1 20 kB	
EV520806	Semi-fixed/Vol. V8K4-1 10 kB	
EV465017	Semi-fixed/Vol. V8K4-1 200 kB	
EV464196	Semi-fixed/Vol. V8K4-1 2 kB	
EV464220	Semi-fixed/Vol. V8K4-1 50 kB	
EV302487	Vol. VM10E076 10 kB	
EV302488	Vol. VE10E076 5 kB	
EV302489	Vol. GM80R 50 kB × 2	
EV302614	Vol. VM10R 50 kA	
EV302629	Vol. GM80R 10 B × 2	
HE636963	ERASE HEAD E4-165	Same as GXC-570D
HP671174	REC/PB HEAD PR4-2	Same as GXC-570D
MB302316	Capstan Belt	
MP612628	Pinch Roller Part CW-0010	Same as GXC-570D

2. ILLUSTRATION OF HEAD BASE BLOCK

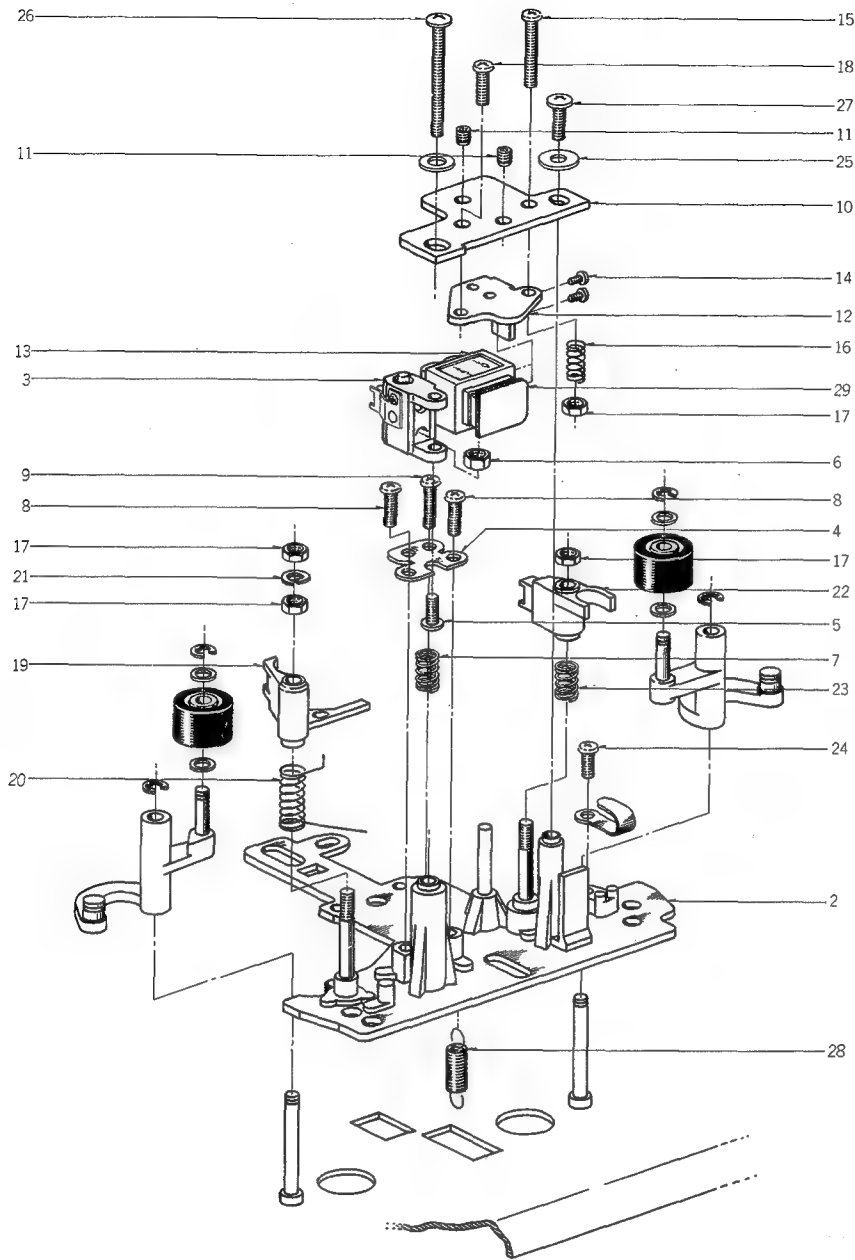

2) HEAD BASE BLOCK

Ref. No.	Parts No.	Description	Schematic No.	Ref. No.	Parts No.	Description	Schematic No.
2-1x	BH302650	Head Base Block Comp. GXC-570D-2		2-15	ZS670004	Screw, pan head 2.3x16	
2-2	HZ302385	Head Base Part CI-2	CI-0201	2-16	ZG465636	Angle Adjust Spring	CG-0029
2-3	HE636963	ERASE HEAD E4-165		2-17	ZW591265	Nut M2.3, #3	
2-4	HZ227103	Erase Head Plate (B)	CA-0213	2-18	ZS487091	Screw, pan head 2.3x8	
2-5	ZS464692	Screw, binding head 2.3x6		2-19	HZ302181	Tape Guide (C)	CI-0207
2-6	ZW699052	Nut, M2.3 D2.3x5x2.3T		2-20	ZG302182	Guide Spring	CI-0208
2-7	ZG289236	Tape Guide Spring	CM-0005	2-21	ZW273666	Spring Washer, M2.3	
2-8	ZS522180	Tapping Screw #2, 2x8 (Pan)		2-22	TC286007	Tape Guide (B)	CM-0002
2-9	ZS302510	Screw, pan head 2x10		2-23	ZG289236	Tape Guide Spring	CM-0005
2-10	HZ302183	Head Hanger (C)	CI-0209	2-24	ZS669104	Tapping Screw #2, 2.3x6 (Pan)	
2-11	ZS356804	Set Screw, hexagon socket 3x4 (CUP/P.)		2-25	ZW452395	Washer (SPC) D2.3x7x0.5t	
2-12	HZ302180	Head Mt. Parts	CI-0205	2-26	ZS302425	Head Hanger Screw	CI-0210
2-13	HP671174	REC/PB HEAD PR4-2		2-27	ZS300436	Tapping Screw #2, 2.3x8 (Bind)	
2-14	ZS300626	Screw, pan head 2x2.5 (Camera Standard)		2-28	ZG595506	Stop Spring	CH-3007
				2-29	EA669510	PR4-1 Terminal P.C Board	CW-0045

When ordering parts, please describe Parts Number, Description, and Model Number in detail.

3. ILLUSTRATION OF REEL TABLE BLOCK

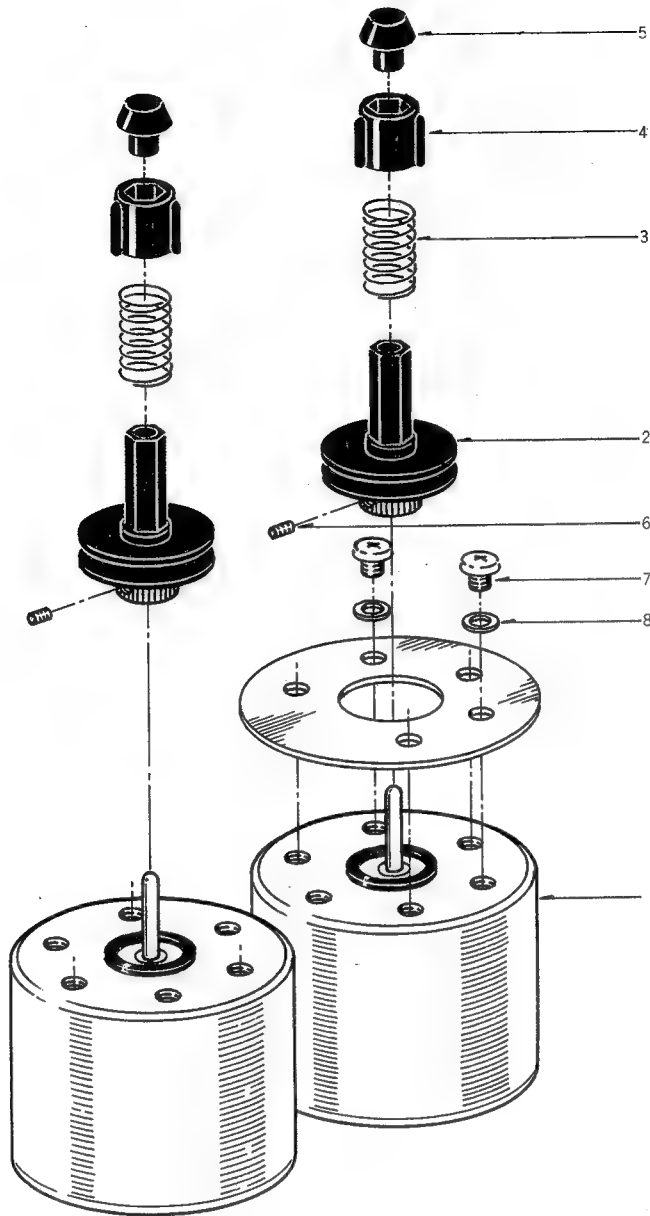

3) REEL TABLE BLOCK

Ref. No.	Parts No.	Description	Schematic No.
3-1	BM302507	Reel Motor RF-510TD	9-2-13
3-2	MT302244	Reel Table Part CI-2	CI-2205
3-3	ZG302350	Reel Table Spring	CI-2217
3-4	MT605766	Reel Table Blade (V Type)	CH-1070
3-5	MT667912	Reel Table Top	CB-2019
3-6	ZS302938	Set Screw, hexagon socket 2x3 (WP)	
3-7	ZS608174	Screw, pan head 2.6x3 (Take-up)	
3-8	ZW318014	Washer (BSP) D2.6x4.5x0.4T (Take-up)	

When ordering parts, please describe Parts Number, Description, and Model Number in detail.

4. ILLUSTRATION OF CASSETTE HOLDER BLOCK

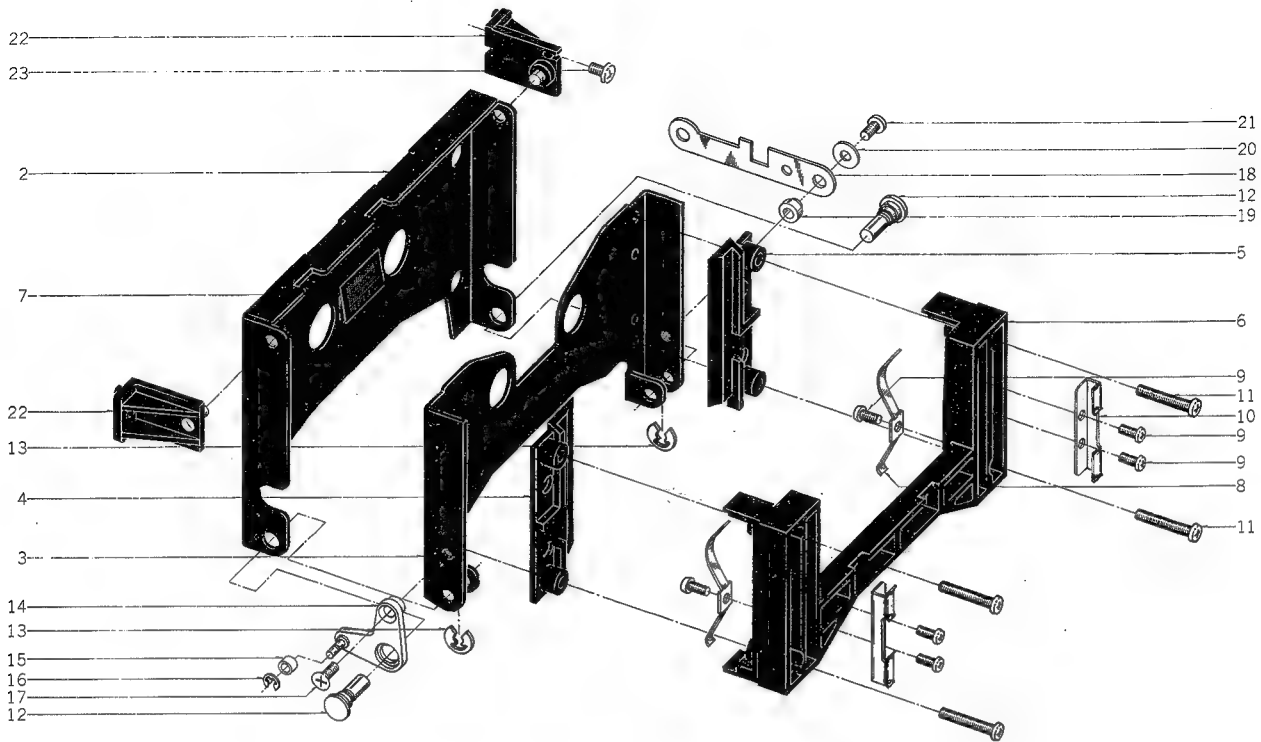

4) CASSETTE HOLDER BLOCK

Ref. No.	Parts No.	Description	Schematic No.
4-1x	BZ302234	Cassette Holder Block Comp. GXC-570D-2	
4-2	TC302245	Trap Part CI-2	CI-2211
4-3	TC292285	Cassette Holder	CA-2023
4-4	MS595563	Cassette Guide (L)	CH-2007
4-5	MS595552	Cassette Guide (R)	CH-2006
4-6	TC647065	Cassette Case	CA-2024
4-7	TC645186	Reflector	CA-2071
4-8	ZG305459	Sheet Spring (C)	CI-2019
4-9	ZS669104	Tapping Screw #2, 2.3x6 (Pan)	
4-10	TC642148	Lid Chuck	CA-2026
4-11	ZS592402	Screw, pan head 3x18	
4-12	MH644916	Hinge Pin	CA-2028
4-13	ZW290283	'U' Ring 2.85M	6-1-1
4-14	ML302246	Eject Guide Arm Part CI-2	CI-2212
4-15	MR305435	Roller	CB-2225
4-16	ZW270088	'E' Ring 1.9M	6-1-9
4-17	ZS414033	Screw, countersunk head 3x8	
4-18	MZ302311	Joint	CI-1249
4-19	MH302312	Sleeve	CI-1250
4-20	ZW550642	Washer (SPC) D3.1x8x0.5t	
4-21	ZS379350	Screw, pan head 3x6	
4-22	TC302142	Stand Part GXC-570D-2	CI-1220
4-23	ZS323728	Screw, binding head 3x5	
4-24x	ZW270101	'E' Ring 3M	6-1-9

When ordering parts, please describe Parts Number, Description, and Model Number in detail.

5. ILLUSTRATION OF MECHA FRAME BLOCK (1)

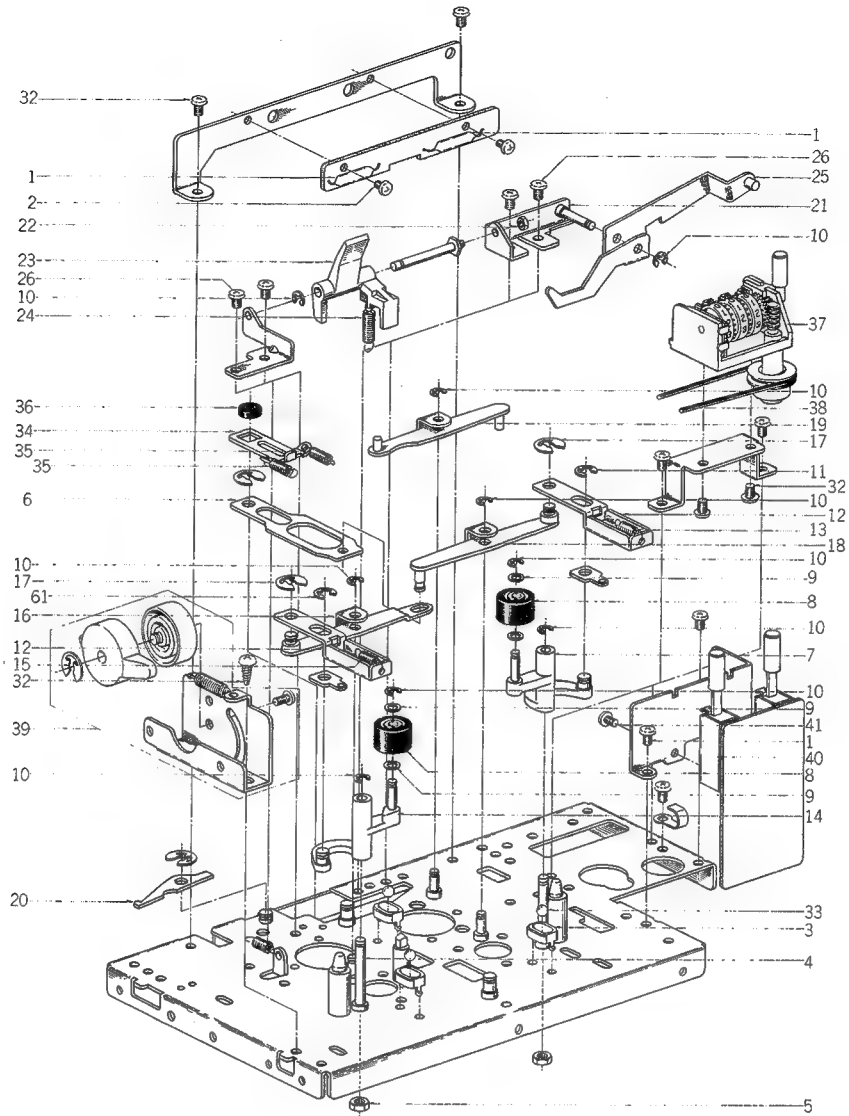

5) MECHA FRAME BLOCK (1)

Ref. No.	Parts No.	Description	Schematic No.	Ref. No.	Parts No.	Description	Schematic No.
		HOUSING LAMP P.C BOARD BLOCK		5-21	ML302139	Hold Bracket Part GXC-570D-2	CI-1223
5-1	EL304025	Lamp (No. 2) 10V 110mA	28-2-66	5-22	ZW609311	Nut M2, #1	
5-2	ZS417251	Screw, binding head 2.3x3		5-23	TC302206	Cassette Push	CI-1226
		MECHA FRAME BLOCK		5-24	ZG595506	Stop Spring	CH-3007
5-3	MS302191	Ball Guide	CI-1209	5-25	ML302141	Up Lever Part GXC-570D-2	CI-1228
5-4	MS302190	Pinch Roller Stud	CI-1208	5-26	ZS200384	Screw, countersunk head 3x6	
5-5	ZW273756	Nut M3, #1		5-27x	TC302142	Stand Part GXC-570D-2	CI-1220
5-6	MZ302192	P Joint	CI-1210	5-28x	ZW305593	Washer D5.1x10.3x0.4t (SUP)	
5-7	TC302134	PW Arm (R) Part GXC-570D-2	CI-1216	5-29x	ZS323728	Screw, binding head 3x5	
5-8	MP612628	Pinch Roller Part CW	CW-0010	5-30x	ZS592378	Screw, pan head 2.6x3	
5-9	ZW282407	Push Washer (B)	CN-1056	5-31x	ZS432843	Screw, pan head 2.6x4	
5-10	ZW270088	'E' Ring 1.9M	6-1-9	5-32	ZS417216	Screw, pan head 3x4	
5-11	ZW270101	'E' Ring 3M	6-1-9	5-33	MV269965	Steel Ball D4	
5-12	ML302199	P Slide	CI-1219	5-34	HZ302202	Head Clutch Plate	CI-1222
5-13	ZG302349	Pinch Roller Spring (R)	CI-1266	5-35	ZG445410	Slide Spring	DF-5036
5-14	TC302135	PW Arm (L) Part GXC-570D-2	CI-1218	5-36	MZ302351	Rubber Bush	CI-1268
5-15	ZG302644	Pinch Roller Spring (L)	CI-1269	5-37	MC302145	Counter GXC-570D-2	9-1-55
5-16	ML302136	P Lever (B) Part GXC-570D-2	CI-1214	5-38	MB302211	Counter Belt	CI-1230
5-17	ZW290283	'U' Ring 2.85M	6-1-1	5-39	TC302695	Oil Clutch (C) Comp. GXC-570D-2	CI-2218
5-18	ML302137	P Lever (A) Part GXC-570D-2	CI-1211				
5-19	ML302138	Play Arm Part GXC-570D-2	CI-1215	5-40	ES419286	Push SW. UEG-22 DE	
5-20	ML302208	Magnification Lever	CI-1227	5-41	ZS592378	Screw, pan head 2.6x3	

When ordering parts, please describe Parts Number, Description, and Model Number in detail.

6. ILLUSTRATION OF MECHA FRAME BLOCK (2)

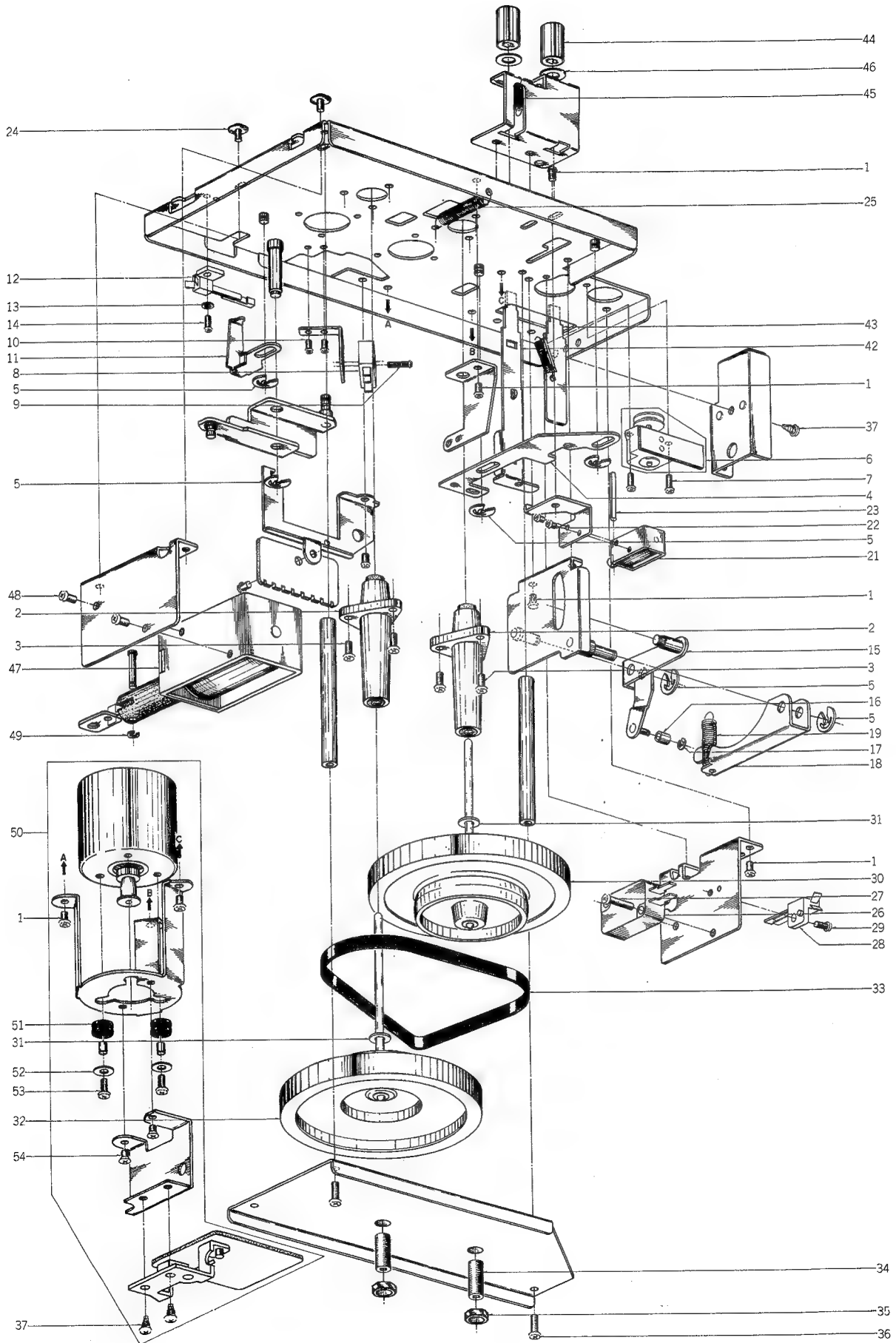

6) MECHA FRAME BLOCK (2)

Ref. No.	Parts No.	Description	Schematic No.
6-1	ZS417216	Screw, pan head 3x4	
6-2	MV302652	Metal Case Part GXC-570D-2	CI-1233
6-3	ZS379350	Screw, pan head 3x6	
6-4	ML302216	Play Slide	CI-1236
6-5	ZW290283	'U' Ring 2.85M	6-1-1
6-6	EZ303003	Rotary SW. Assy GXC-570D-2	CI-9813
6-7	ZS608106	Screw, pan head 2x6	
6-8	ES302940	Micro SW. SS-5GLC	25-1-46
6-9	ZS465298	Screw, pan head 2.3x10	
6-10	ZS460440	Screw, pan head 2x4	
6-11	ML302213	Detection Lever	CI-1232
6-12	ES302448	Leaf SW. BSW-81 CI-2	25-10-28
6-13	ZW259367	Washer (BSP) D2.4x4.5x0.3t	
6-14	ZS537085	Screw, binding head 2x5	
6-15	ML302653	Lock Lever (B) Part GXC-570D-2	CI-1244
6-16	MR302309	Roller (1)	CI-1247
6-17	ZW391397	'E' Ring 1.2M	6-1-9
6-18	ML302310	Lock Lever	CI-1248
6-19	ZG580768	Spoke Spring	TD-2077
6-20x	ZS421806	Screw, pan head 3x8	
6-21	EP302445	Plunger Solenoid P-120F	44-1-90
6-22	ZS300626	Screw, pan head 2x2.5 (Camera Standard)	
6-23	MH302446	Spring Pin SPP 2x20	
6-24	ZS608275	Screw, pan head 3x5, w/washer	
6-25	ZG317114	Tension Lever Spring	MR-39
6-26	ES305231	Micro SW. AH7450261	25-1-48
6-27	ZS419670	Screw, pan head 3x12	
6-28	ES283151	Leaf SW. BSW-31 (PL)	25-10-25
6-29	ZS537085	Screw, binding head 2x5	
6-30	BF302647	Flywheel (B) Part GXC-570D-2	CI-1255
6-31	ZW302401	Washer (Nylon)	CI-1267
6-32	BF302648	Flywheel (A) Part GXC-570D-2	CI-1253
6-33	MB302316	Capstan Belt	CI-1256
6-34	ZS302318	Holder Screw	CI-1258
6-35	ZW303680	Metal Nut	CI-1273
6-36	ZS421806	Screw, pan head 3x8	
6-37	ZS325495	Tapping Screw #2, 3x6 (BR)	
6-38x	ZS447840	Tapping Screw #2, 3x8 (BR)	
6-39x	SK302459	Memory Cap (B)	CI-5236
NOISE FILTER P.C BOARD BLOCK			
6-40x	EO669273	Inductor FL5R-200	23-1-248
6-41x	ZS558101	Screw, pan head 3x6 w/washer	
EJECT KEY BLOCK			
6-42	TC302329	Eject Key	CI-2208
6-43	TC302330	Door Key	CI-2209
6-44	SK300103	Push Button Knob (M) CM-2	91-5051
6-45	ZG387178	Idler Tension Spring	CS-1106
6-46	ZW259942	Washer (Fiber) D5.1x10.3x0.5t	
PLUNGER BLOCK			
6-47	EP302690	Plunger Solenoid TDS-12E	44-1-95
6-48	ZS422076	Screw, pan head 3x5	
6-49	ZW270088	'E' Ring 1.9M	6-1-9
CAPSTAN MOTOR BLOCK			
6-50	BM302656	Capstan Motor Block Comp. GXC-570D-2	CI-1270
6-51	MB282778	Rubber Bush	CN-7003
6-52	ZW550697	Washer (SPC) D2.9x7.4x0.5t	
6-53	ZS608220	Screw, pan head 2.6x6	
6-54	ZS444330	Screw, countersunk head 3x4	

7. P.C BOARDS

(1) AMP P.C BOARD (CI-5202A) BLOCK

Symbol No.	Parts No.	Description	Schematic No.	Symbol No.	Parts No.	Description	Schematic No.
(1)-1	BA302529	Amp P.C Board Comp. GXC-570D-2		(1)-R87	ER302468	Metal Oxide Film/R. ERO 1/4W 100 ohms (G)	35-17-11
(1)-IC1,2	EI301463	IC CR-713B	45-8-225	(1)-R112	ER301441	Metal Oxide Film/R. 2W 330 ohms (J)	35-15-8
(1)-TR1	ET632204	Transistor 2SC945L (K)(P)(Q)	45-1-85	CAPACITOR, VERTICAL TYPE			
(1)-TR2	ET391768	Transistor 2SC458LG(C)(D)	45-1-29	(1)-C5	EC516712	Styrol 220PF (K) 50WV	24-11-3
(1)-TR3,4	ET632204	Transistor 2SC945L(K)(P)(Q)	45-1-85	(1)-C15	EC619650	Solid Aluminum 0.1μF(K) 25WV	24-19-2
(1)-TR5	ET635220	Transistor 2SC945L(K)(P)	45-1-85	(1)-C16	EC604102	Solid Aluminum 0.33μF(K) 25WV	24-19-2
(1)-TR6	ET539133	Transistor 2SA733 (P)	45-1-124	(1)-C27	EC604102	Solid Aluminum 0.33μF(K) 25WV	24-19-2
(1)-TR7,8	ET429748	Transistor 2SC711 (H)	45-1-67	(1)-C28	EC662308	Solid Aluminum 0.15μF(K) 25WV	24-19-2
(1)-TR9	ET208012	Transistor 2SD571 (K)	45-1-218	(1)-C29	EC619650	Solid Aluminum 0.1μF(K) 25WV	24-19-2
(1)-TR10to12	ET632204	Transistor 2SC945L(K)(P)(Q)	45-1-85	(1)-C34,36	EC562678	Styrol 750PF (J) 50WV	24-11-3
(1)-TR13	ET208012	Transistor 2SD571 (K)	45-1-218	(1)-C50	EC302462	Styrol 1200PF(J) 500WV	24-11-3
(1)-TR14	ET302466	FET 2SK68A (Special)	45-12-17	(1)-C52	EC572793	Styrol 250PF (J) 50WV	24-11-3
(1)-TR15	ET302456	Transistor 2SA906(G)(H)	45-1-280	(1)-C53	EC476954	Elect. 100μF 25WV NL	24-20-4
(1)-TR16,17	ET391768	Transistor 2SC458LG(C)(D)	45-1-29	(1)-C54	EC623002	Styrol 820PF(K) 50WV	24-11-3
(1)-D1to3	ED219464	Germanium Diode 1N34A	45-3-1	(1)-C55	EC575188	Tantalum (DTS Type) 22μF (M) 16WV	24-15-8
(1)-D4to8	ED560913	Silicon Diode 1S2473VE	45-3-23	(1)-C56	EC572613	Tantalum (DTS Type) 10μF (M) 16WV	24-15-8
(1)-D9	ED624903	Silicon Diode 1S2473	45-3-28	(1)-C58	EC516688	Styrol 100PF (K) 50WV	24-11-3
(1)-D10,11	ED560913	Silicon Diode 1S2473VE	45-3-23	(1)-C63	EC662308	Solid Aluminum 0.15μF(K) 25WV	24-19-2
(1)-D13	ED219464	Germanium Diode 1N34A	45-3-1	(1)-C65	EC565830	Styrol 200PF(J) 50WV	2411-3
(1)-RL1	EP249344	Reed Relay, L Type L24	47-2-28	(1)-C74	EC619650	Solid Aluminum 0.1μF(K) 25WV	24-19-2
(1)-RL2	EP691446	Relay MZ-24HG	47-2-27	(1)-C75	EC604102	Solid Aluminum 0.33μF (K) 25WV	24-19-2
(1)-L1	EO302464	Inductor RX-9P 33MH(J)	23-1-275				
(1)-L2,3	EO301711	Coil RX-9P 3.3MH (J)	23-1-275				
(1)-VL1	EO692741	Ferri Inductor 33Y-740	23-1-254				
(1)-T1	EO301466	Osc. Coil 28N-503	23-4-46				
(1)-FL1	ER300433	Dolby Filter KM-10D100B	53-1-115				
(1)-FL2	ER283105	Dolby Filter KM-10D19B	53-1-115				
(1)-FL3	ER300433	Dolby Filter KM-10D100B	53-1-115				
(1)-VR1	EV520806	Semi-fixed/Vol. V8K4-1 10 kB	36-10-266				
(1)-VR2	EV302487	Vol. VM10E076 10kB	36-6-29				
(1)-VR3	EV464207	Semi-fixed/Vol. V8K4-1 5 kB	36-10-266				
(1)-VR4	EV302488	Vol. VE10E076 5 kB	36-6-30				
(1)-VR5,6	EV522797	Semi-fixed/Vol. V8K4-1 20 kB	36-10-266				
(1)-VR7	EV520806	Semi-fixed/Vol. V8K4-1 10 kB	36-10-266				
(1)-VR8	EV465017	Semi-fixed/Vol. V8K4-1 200 kB	36-10-266				
(1)-VR9	EV464196	Semi-fixed/Vol. V8K4-1 2 kB	36-10-266				
(1)-VR10	EV464220	Semi-fixed/Vol. V8K4-1 50 kB	36-10-266				
(1)-VR11	EV302489	Vol. GM80R 50 kB	36-22-31				
(1)-SW1	ES302492	Push SW. SUE-12	25-5-260				
(1)-SW2	ES302491	Push SW. SUE-34	25-5-259				
(1)-SW3	ES303681	Rotary Slide SW. SRZ-V104N	25-6-116				
(1)-J1	EJ301714	Jack Plate NE-2	31-5-138				
(1)-2	TC289484	SW. Joint	CM-6015				
(1)-R23	ER301441	Metal Oxide Film/R. 2W 330 ohms (J)	35-15-8				
(1)-R85	ER302460	Metal Oxide Film/R. ERO 1/4W 47k (G)	35-17-11				
(1)-R86	ER302467	Metal Oxide Film/R. ERO 1/4W 4.7k (G)	35-17-11				

When ordering parts, please describe Parts Number, Description, and Model Number in detail.

(2) POWER SUPPLY P.C BOARD (CI-5206) BLOCK

Symbol No.	Parts No.	Description	Schematic No.
(2)-1	BA301344	Power Supply P.C Board Comp. GXC-570D-2 (U/T) (CEE, BEAB)	CI-9820
(2)-2	BA301343	Power Supply P.C Board Comp. GXC-570D-2 (JPN)(CSA,AAL,SAA)	CI-9820
(2)-TR2	ET635220	Transistor 2SC945L(K)(P)	45-1-85
(2)-TR4	ET303895	Transistor 2SD667(C)(D)	45-1-296
(2)-TR5	ET635220	Transistor 2SC945L(K)(P)	45-1-85
(2)-TR6	ET208012	Transistor 2SD571(K)	45-1-218
(2)-TR9	ET635220	Transistor 2SC945L(K)(P)	45-1-85
(2)-TR10	ET208012	Transistor 2SD571(K)	45-1-218
(2)-TR11,12	ET635220	Transistor 2SC945L(K)(P)	45-1-85
(2)-D1to3	ED249581	Silicon Diode SIQB20 0.6A 200V (RED)	45-2-74
(2)-D4	ED303156	Zener Diode 05Z-22U	45-6-76
(2)-D5	ED224526	Silicon Diode 10D1	45-2-11
(2)-D6	ED303155	Zener Diode 05Z-5.6U	45-6-76
(2)-D7	ED302643	Zener Diode RD-4.3E(B)	45-6-72
(2)-D9to11	ED560913	Silicon Diode 1S2473VE	45-3-23
(2)-D12	ED510772	Zener Diode WZ-120	45-6-67
(2)-D13	ED304243	Zener Diode XZ-147	45-6-69
(2)-D14to16	ED560913	Silicon Diode 1S2473VE	45-3-23
(2)-R7	ER678576	Metal Oxide Film/R. 2W 220 ohms (J)	35-15-8
(2)-3	ZS325495	Tapping Screw #2, 3x6 (BR)	

(3) SYS. CON (CI-5209A/B/C) BLOCK

Symbol No.	Parts No.	Description	Schematic No.
(3)-1	BA302089	Sys. Con Block Comp. GXC-570D-2	
(3)-2	ZS417216	Screw, pan head 3x4	
SYS. CON P.C BOARD (CI-5209A) BLOCK			
(3)-IC1to3	EI430661	IC M53200P	45-8-38
(3)-IC4to6	EI592198	IC M53220P	45-8-113
(3)-IC7	EI633960	IC M53202P	45-8-140
(3)-IC8,9	EI573840	IC M53204P	45-8-106
(3)-TR1to5	ET635220	Transistor 2SC945L(K)(P)	45-1-85
(3)-TR6,7	ET242684	Transistor 2SC1312S(H)	45-1-182
(3)-TR8	ET398777	Transistor 2SC711(G)(F)	45-1-67
(3)-TR9,10	ET242684	Transistor 2SC1312S(H)	45-1-182
(3)-TR11	ET398777	Transistor 2SC711(G)(F)	45-1-67
(3)-TR12,13	ET242684	Transistor 2SC1312S(H)	45-1-182
(3)-TR14	ET398777	Transistor 2SC711(G)(F)	45-1-67
(3)-TR15,16	ET242684	Transistor 2SC1312S(H)	45-1-182
(3)-TR17	ET398777	Transistor 2SC711(G)(F)	45-1-67
(3)-TR18,19	ET242684	Transistor 2SC1312S(H)	45-1-182
(3)-TR20	ET398777	Transistor 2SC711(G)(F)	45-1-67
(3)-TR21,22	ET242684	Transistor 2SC1312S(H)	45-1-182
(3)-TR23,24	ET398777	Transistor 2SC711(G)(F)	45-1-67
(3)-TR25	ET539133	Transistor 2SA733(P)	45-1-124
(3)-TR26to32	ET398777	Transistor 2SC711(G)(F)	45-1-67
(3)-TR33	ET302502	Transistor 2SC2001(K)	45-1-272
(3)-TR34	ET242684	Transistor 2SC1312S(H)	45-1-182
(3)-TR35	ET304446	Transistor 2SB562(C)(D)	45-1-297
(3)-TR36	ET242684	Transistor 2SC1312S(H)	45-1-182
(3)-TR37	ET304446	Transistor 2SB562(C)(D)	45-1-297
(3)-TR38,39	ET302502	Transistor 2SC2001(K)	45-1-272
(3)-TR40	ET398777	Transistor 2SC711(G)(F)	45-1-67
(3)-D1	ED560913	Silicon Diode 1S2473VE	45-3-23
(3)-D2,3	ED219464	Germanium Diode 1N34A	45-3-1
(3)-D4	ED560913	Silicon Diode 1S2473VE	45-3-23
(3)-D5	ED219464	Germanium Diode 1N34A	45-3-1
(3)-D6	ED560913	Silicon Diode 1S2473VE	45-3-23
(3)-D7,8	ED219464	Germanium Diode 1N34A	45-3-1
(3)-D9	ED560913	Silicon Diode 1S2473VE	45-3-23
(3)-D10,11	ED219464	Germanium Diode 1N34A	45-3-1
(3)-D12	ED560913	Silicon Diode 1S2473VE	45-3-23
(3)-D13,14	ED219464	Germanium Diode 1N34A	45-3-1
(3)-D15	ED560913	Silicon Diode 1S2473VE	45-3-23
(3)-D16,17	ED219464	Germanium Diode 1N34A	45-3-1
(3)-D18	ED560913	Silicon Diode 1S2473VE	45-3-23
(3)-D19to22	ED219464	Germanium Diode 1N34A	45-3-1
(3)-D23	ED560913	Silicon Diode 1S2473VE	45-3-23
(3)-D24to26	ED219464	Germanium Diode 1N34A	45-3-1
(3)-D27	ED560913	Silicon Diode 1S2473VE	45-3-23
(3)-D28to34	ED219464	Germanium Diode 1N34A	45-3-1
(3)-D35	ED560913	Silicon Diode 1S2473VE	45-3-23
(3)-D36	ED219464	Germanium Diode 1N34A	45-3-1
(3)-D38	ED557447	Silicon Diode 1S1588	45-3-22
(3)-D39to42	ED560913	Silicon Diode 1S2473VE	45-3-23
(3)-D43,44	ED219464	Germanium Diode 1N34A	45-3-1
(3)-D45,46	ED560913	Silicon Diode 1S2473VE	45-3-23
(3)-R3	ER303040	Solid/R. ERC 1/8W 35M(M)	35-5-12
(3)-R8	ER303040	Solid/R. ERC 1/8W 35M(M)	35-5-12
(3)-R12	ER303040	Solid/R. ERC 1/8W 35M(M)	35-5-12

(4) PEAK CIRCUIT P.C BOARD (CI-5203)
BLOCK

Symbol No.	Parts No.	Description	Schematic No.
(3)-R16	ER303040	Solid/R. ERC 1/8W 35M(M)	35-5-12
(3)-R20	ER303040	Solid/R. ERC 1/8W 35M(M)	35-5-12
(3)-R24	ER303040	Solid/R. ERC 1/8W 35M(M)	35-5-12
(3)-R33	ER303342	Metal Oxide Film/R. 1W 330 ohms (J)	35-15-17
(3)-R34	ER658034	Metal Oxide Film/R. 2W 220 ohms (J)	35-15-18
(3)-R38	ER302372	Cement/R. (Wire Wound Type) 10W 43 ohms(K)	35-16-72
(3)-C25	EC304431	Tantalum/C. (D Type) 22μF(M) 6.3WC	24-15-12
(3)-C28	EC304431	Tantalum/C. (D Type) 22μF(M) 6.3WV	24-15-12
(3)-C36	EC304431	Tantalum/C. (D Type) 22μF(M) 6.3WV	24-15-12
(3)-C50	EC516767	Styrol/C. (Vert. Type) 470PF(K) 50WV	24-11-3

REMOTE CONTROL P.C BOARD (CI-5209B) BLOCK

(3)-3	EJ303033	Socket, Sub Magnale	31-1-212
-------	----------	---------------------	----------

AS P.C BOARD (CI-5209C) BLOCK

(3)-4	BA302077	AS P.C Board Comp. GXC-570D-2	
(3)-TR1to3	ET398777	Transistor 2SC711(G)(F)	45-1-67
(3)-D1to3	ED560913	Silicon Diode 1S2473VE	45-3-23
(3)-D4,5	ED619784	Germanium Diode 1N60	45-3-35
(3)-SW1,2	ES419286	Push SW. UEG-22DE	25-5-33
(3)-P1	EJ302984	Micro Connector 3P Plug W-P0503	42-1-104
(3)-5	ZS592378	Screw, pan head 2.6x3	

Symbol No.	Parts No.	Description	Schematic No.
(4)-1	BA302080	Peak Circuit P.C Board Comp. GXC-570D-2	CI-9806
(4)-IC1	EI302623	IC TA-7139P	45-8-227
(4)-IC2	EI669666	IC MPC1023H	45-8-164
(4)-TR1to5	ET635220	Transistor 2SC945L(K)(P)	45-1-85
(4)-TR6	ET429748	Transistor 2SC711 (H)	45-1-67
(4)-TR7	ET302502	Transistor 2SC2001 (K)	45-1-272
(4)-TR8	ET302539	Transistor 2SA952 (K)	45-1-271
(4)-D1,2	ED624903	Silicon Diode 1S2473	45-3-28
(4)-D3to5	ED560913	Silicon Diode 1S2473VE	45-3-23
(4)-SW1	ES302615	Push SW. SPV	25-5-261
(4)-VR1,2	EV302614	Vol. VM10R 50 KA	36-6-31
(4)-VR3,4	EV464220	Semi-fixed/Vol. V8K4-1 50 kB	36-10-266
(4)-FR1	ER561216	Fuse/R. FRN1/4 100 ohms (K) 50MA	35-14-9
(4)-C2	EC476954	Elect./C. (Vert. Type) 100μF 25WV NL	24-20-4
(4)-C3	EC405898	Styrol/C. (Vert. Type) 470PF(J) 50WV	24-11-3
(4)-C4	EC231783	Tantalum/C. (DTS Type) 22μF (K) 6.3WV	24-15-8
(4)-C10	EC513990	Styrol/C. (Vert. Type) 330PF (J) 50WV	24-11-3

(5) MONITOR SW. P.C BOARD (CI-5205)
BLOCK

Symbol No.	Parts No.	Description	Schematic No.
(5)-1	BA302082	Monitor SW. P.C Board Comp. GXC-570D-2	CI-9807
(5)-TR1	ET304169	FET 2SK68 (L) (M)	45-12-14
(5)-TR2	ET632204	Transistor 2SC945L(K)(P)(Q)	45-1-85
(5)-D1,2	ED219464	Germanium Diode 1N34A	45-3-1
(5)-D3	ED560913	Silicon Diode 1S2473VE	45-3-23
(5)-SW1	ES691424	Lever SW. SLK04251	25-12-26
(5)-VR1	EV302629	Vol. GM80R 10B x 2	36-22-33
(5)-C5	EC432808	Elect./C. (Vert. Type) 0.47 μ F 50WV NL	24-20-4

(6) DOOR OPEN P.C BOARD (CI-5211)
BLOCK

Symbol No.	Parts No.	Description	Schematic No.
(6)-1	BA302555	Door Open P.C Board Comp. GXC-570D-2	CI-9819
(6)-TR1	ET302539	Transistor 2SA952 (K)	45-1-271
(6)-TR2	ET302502	Transistor 2SC2001 (K)	45-1-272
(6)-D1	ED560913	Silicon Diode 1S2473VE	45-3-23
(6)-D2,3	ED303034	Zener Diode WZ-054	45-6-67
(6)-D4	ED560913	Silicon Diode 1S2473VE	45-3-23
(6)-L1,2	EO669273	Inductor FL5R-200	23-1-248
(6)-R1	ER302541	Metal Oxide Film/R. 3W 120 ohms (J)	35-15-9
(6)-R4	ER302541	Metal Oxide Film/R. 3W 120 ohms (J)	35-15-9
(6)-C1	EC657044	NP/C. (Vert. Type) 1 μ F (M) 50WV	24-17-26

8. ILLUSTRATION OF ASSEMBLY BLOCK

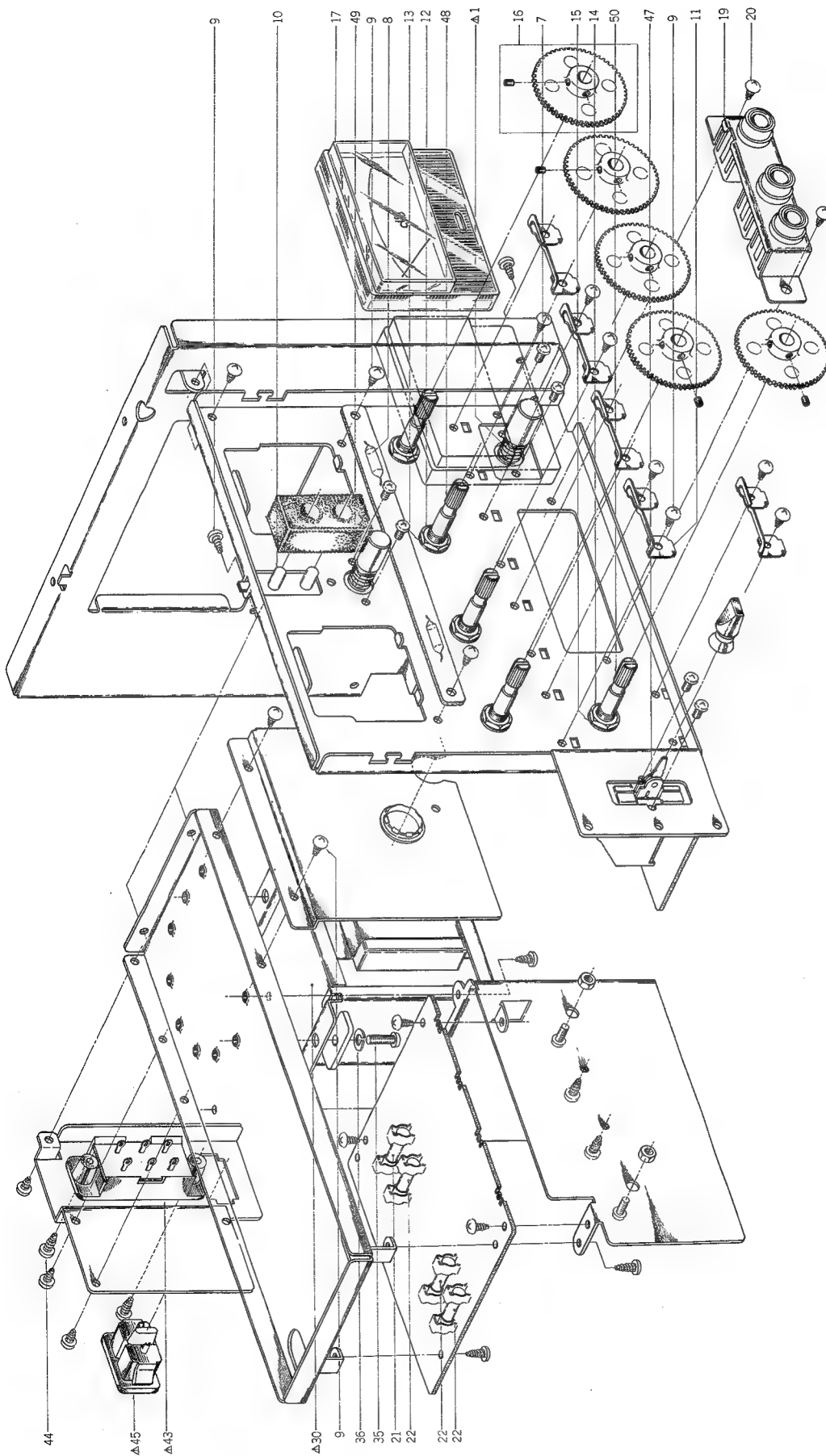

8) ASSEMBLY BLOCK

Ref. No.	Parts No.	Description	Schematic No.	Ref. No.	Parts No.	Description	Schematic No.
POWER SUPPLY SW. P.C BOARD (A) BLOCK				8-44	ZS447840	Tapping Screw #2, 3x8 (BR) (U/T, CEE, BEAB)	
8-1	ES665807	△ Push SW. SDG-5P 5A/80A 250V (U/T, CEE, BEAB)	25-5-182	8-45	EJ301513	△ 2P Inlet (U/T, CEE, BEAB)	31-1-200
8-2x	EC283375	△ MP/C. PME271M547 0.047μF 250WV (U/T, CEE, BEAB)	24-9-118	8-46x	ZS447840	Tapping Screw #2, 3x8 (BR)	
POWER SUPPLY SW. P.C BOARD (B) BLOCK				8-47	ES691424	Lever SW. SLK04251	25-12-26
8-3x	ES293703	△ Push SW. SDV1P TV-5 (w/o label) (JPN, SAA, CSA)	25-5-254	8-48	EV302614	Vol. VM10R 50 kA	36-6-31
8-4x	ES280258	△ Push SW. SDV1P TV-5 (W/label) (AAL)	25-5-243	8-49	ES302615	Push SW. SPV	25-5-261
8-5x	EC551160	△ Ceramic/C. DB821 NA 0:01μF (Z) 1.4 kWV (JPN, SAA)	24-5-55	8-50	EV302629	Vol. GM80R 10 kB x2	36-22-33
8-6x	EC286198	△ Ceramic/C. AL-10 0.01μF(Z) 125WV	24-5-69				
POWER SW. BLOCK							
8-7	ZS417216	Screw, pan head 3x4					
CONTROL CHASSIS BLOCK							
8-8	EL304685	Lamp (L/T) 10V 130mA	28-2-67				
8-9	ZS325495	Tapping Screw #2, 3x6(BR)					
8-10	ML302356	Lamp (Reed Type) 8V 60mA	28-2-62				
8-11	ZG535454	Click Spring	TW-5020				
8-12	ZW302085	M7 Nut, #3	36-6-31				
8-13	ZW302086	Flat Washer	36-6-31				
8-14	ZW302679	M7 Nut, #3	36-22-33				
8-15	ZW302680	Flat Washer	36-22-33				
8-16	TC303218	Click Gear Assy	CI-9818				
8-17	EM303428	VU Meter KL-250L-11	46-1-169				
8-18x	EM302355	VU Meter KL-250L-12 (JPN)	46-1-172				
8-19	EJ303038	3 throw Jack (New) GXC-570D-2	31-2-88				
8-20	ZS297641	Tapping Screw #2, 3x8 (Bind) W=8					
POWER SUPPLY BLOCK							
8-21	EF258344	△ Fuse (SEMKO T Type) 800mA (U/T, CEE, BEAB)	39-1-53				
8-22	EF601301	△ Fuse (SEMKO T Type) 2AT (U/T, CEE, BEAB)	39-1-53				
8-23x	EF563681	△ Fuse 1A 250V (JPN, CSA)	39-1-50				
8-24x	EF304626	△ Fuse ST-4 1A (AAL)	39-1-28				
8-25x	EF563681	△ Fuse 1A 250V (SAA)	39-1-50				
HEAT-SINK BLOCK							
8-26x	ET242370	Transistor 2SD234 (Y)	45-1-81				
8-27x	ET305235	Transistor 2SC1846 (R)	45-1-267				
8-28x	ZS421806	Screw, pan head 3x8					
8-29x	ZW273756	Nut M3, #1					
TRANS. BASE BLOCK							
8-30	BT302548	△ Power Trans. CIT-33 (U/T, CEE, BEAB)	38-4-537				
8-31x	BT302545	△ Power Trans. CIT-32 (JPN)	38-4-547				
8-32x	BT302551	△ Power Trans. CIT-35 (CSA)	38-4-551				
8-33x	BT302549	△ Power Trans. CIT-34 (AAL)	38-4-549				
8-34x	BT302047	△ Power Trans. CIT-36 (SAA)	38-4-554				
8-35	ZS302937	S Tight Screw, 4x12 (Pan)					
8-36	ZW273914	Spring Washer M4					
8-37x	ZW273802	Toothed Lock Washer M3 (SAA)					
8-38x	EZ631945	Strain Relief SR-4N-4 (JPN, CSA, AAL)	2-7-49				
8-39x	EZ246936	Strain Relief SR-6W-1 (SAA)	2-7-8				
8-40x	EW524845	△ AC Cord (J) 2.5M (JPN)	26-3-31				
8-41x	EW207742	△ AC Cord CUL (CSA, AAL)	26-3-45				
8-42x	EW699827	△ AC Cord SAA VM-0118 (SAA)	26-3-39				
8-43	ES301510	△ Slide SW. (B) (U/T, CEE, BEAB)	25-3-143				

When ordering parts, please describe Parts Number, Description, and Model Number in detail.

9. ILLUSTRATION OF TOUCH BUTTON BLOCK

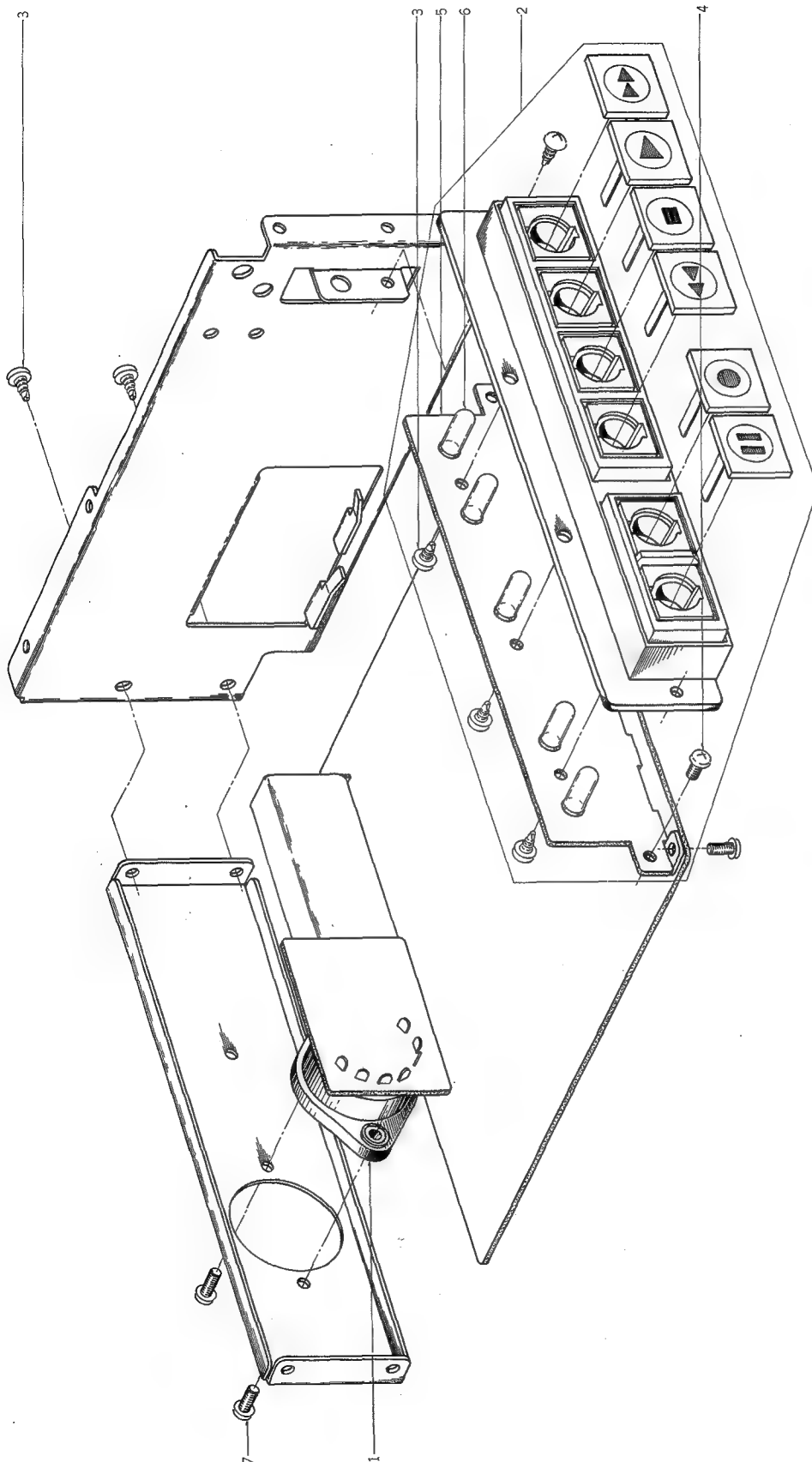

9) TOUCH BUTTON BLOCK

Ref. No.	Parts No.	Description	Schematic No.
REMOTE CONTROL P.C BOARD BLOCK			
9-1	EJ303033	Socket, sub magnale	31-1-212
TOUCH BUTTON BLOCK			
9-2	BK302705	Touch Button Block Comp. GXC-570D-2	CI-9809
9-3	ZS325495	Tapping Screw #2, 3x6 (BR)	
9-4	ZS417216	Screw, pan head 3x4	
TOUCH SENSOR P.C BOARD BLOCK			
9-5	EA302369	Touch Sensor P.C Board	CI-5210
9-6	EL621167	Lamp (L/T) 5.5V 60mA	28-2-36
9-7	ZS447840	Tapping Screw #2, 3x8 (BR)	

10. ILLUSTRATION OF DOOR OPEN BLOCK

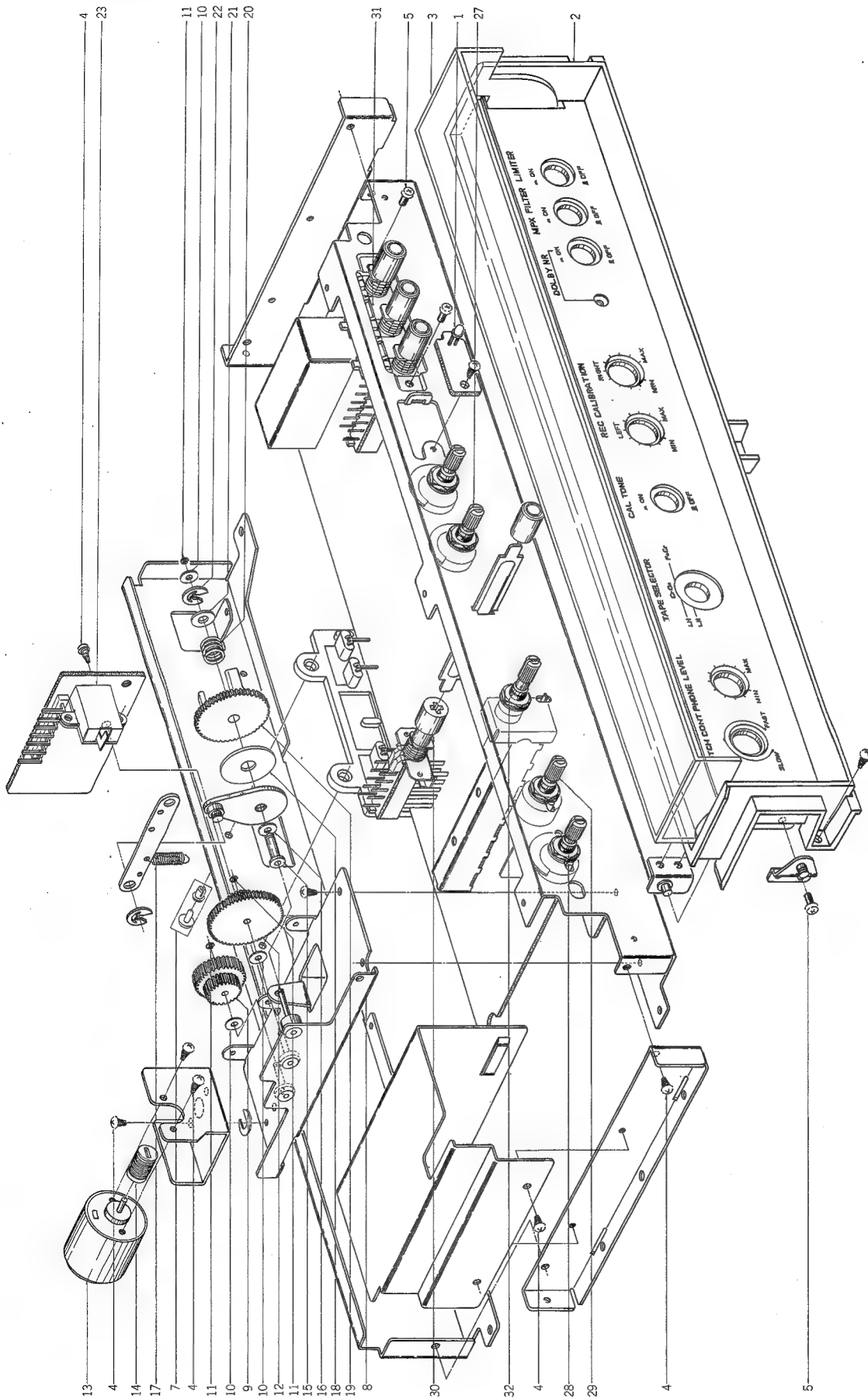

10) DOOR OPEN BLOCK

Ref. No.	Parts No.	Description	Schematic No.
LED P.C BOARD BLOCK			
10-1	ED283138	LED GL-3PG1	45-15-15
SELECTOR BOX BLOCK			
10-2	TC302393	Selector Box	CI-6203/6204
10-3	BC694708	Dust Cover	CI-6002
10-4	ZS325495	Tapping Screw #2, 3x6 (BR)	
10-5	ZS379350	Screw, pan head 3x6	
10-6x	ZW590207	Nut M3, #3	
AMP CHASSIS BLOCK			
10-7	ZW231030	Nylon Rivet (FNRP) 3x4.5 (BLACK)	2-7-54
DOOR OPEN BLOCK			
10-8	MZ303223	Door Open Base Part GXC-570D-2	CI-5227
10-9	MI302344	Worm-wheel	CI-5229
10-10	ZW474592	Washer (Teflon) D2.1x7x0.2t	
10-11	ZW391397	'E' Ring 1.2M	6-1-9
10-12	TC690952	Middle Gear	CI-5019
10-13	BM692550	Motor RF-260-09400	9-2-8
10-14	TC302910	Worm	CI-5232
10-15	TC568361	Wheel Collar	CP-1054
10-16	ZW589893	Washer (PBP) D4.1x7x0.4t	
10-17	ZG244067	Door Open Spring	C-5043
10-18	MT632733	Clutch Felt	CW-1078
10-19	TC300058	Friction Wheel (2)	CI-5049
10-20	ZG227586	Spring (K)	900-214
10-21	ZW450753	Washer (Nylon) D4.2x9x1t	
10-22	ZW290283	'U' Ring 2.85M	6-1-1
10-23	ES302542	Snap SW. SAC-22D	25-9-6
10-24x	ZS432843	Screw, pan head 2.6x4	
10-25x	ZW659171	Adjust. Washer (U) D4.5x10x0.4t	
10-26x	ZW305595	Adjust. Washer (U) D4.5x10x0.25t	
10-27	EV302487	Vol. VM10E076 10 kB	36-6-29
10-28	EV302488	Vol. VM10E076 5 kB	36-6-30
10-29	EV302489	Vol. GM80R 50 kBx2	36-22-31
10-30	ES302492	Push SW. SUE-12	25-5-260
10-31	ES302491	Push SW. SUE-34	25-5-259
10-32	ES303681	Rotary Slide SW. SRZ-V104N	25-6-116

11) PHOTO OF FINAL ASSEMBLY BLOCK



11) FINAL ASSEMBLY BLOCK

Ref. No.	Parts No.	Description	Schematic No.
LID PANEL BLOCK			
11-1	BD303221	Lid Panel Block Comp. GXC-570D-2	
11-2	SM518310	Name Plate (GX) (B)	CG-6411
FRONT PANEL BLOCK			
11-3	BD302601	Front Panel Block Comp. GXC-570D-2	
11-4	SE691255	Counter Escutcheon	CI-6017
11-5	TC691233	SW. Collar (B)	CI-6015
11-6	SE639707	Lamp Lens (B-3)	NE-6005
11-7x	BA693360	Frame	CI-1015
11-8	SE303684	Escutcheon (1)	CI-6208
CASE BLOCK			
11-9	BC302419	Case Block Comp. GXC-570D-2	
11-10	SA640934	Square Foot TY	TE-6020
11-11x	ZS200610	Tapping Screw #1, 4x12 (Truss)	
FINAL ASSEMBLY BLOCK			
11-12x	ZW290294	'U' Ring 2.85M	6-1-1B
11-13	SK302698	Power Knob (A)	CI-5234
11-14	SK302697	Push Button Knob (N) CI-2	91-5051
11-15	SK607127	Push Knob (A) (Black)	A5-5022
11-16	SK300983	Tape Knob	NE-6234
11-17	SK691290	Adjust Knob	CI-6021
11-18	ZW691266	Panel Washer	CI-6018
11-19	ZS691277	Panel Screw	CI-6019
11-20	SK694710	Knob (1) GXC-570D	CI-6022
11-21	SK694721	Knob (2) GXC-570D	CI-6023
11-22	ES691323	Tape SW. (1) GXC-570D	CI-6028
11-23x	ZW259571	Washer (SPC) D3.4x13x1t	
11-24x	ZS462802	Tapping Screw #2, 3x15 (BR)	
11-25	SB614428	Power Button (B)	A5-5021
11-26x	EW302899	△ Cord Set U/T Type 2	26-3-60

When ordering parts, please describe Parts Number, Description, and Model Number in detail.

12. LIST OF INTERCHANGEABLE SEMICONDUCTORS

If, while servicing, the original parts cannot be obtained, the interchangeable parts listed below can be substituted.

Original Parts			Interchangeable Parts	
Description	Parts No.	Utilizing P.C Board	Description	Parts No.
2SA733(P)	ET539133	CI-5202A CI-5209A	2SA564(Q)(R) 2SA628(D)(E)(F)(G)	ET538154 ET539144
2SA906(G)(H)	ET302456	CI-5202A		
2SA952(K)(L) 2SA952(K)	ET302296 ET302539	CI-5209A CI-5203 CI-5211		
2SC458LG(C)(D)	ET391768	CI-5202A	2SC693U(F)(G) 2SC1312S(G)(H)	ET429647 ET603257
2SC945L(K)(P)(Q) 2SC945L(K)(P) 2SC945L(Q)(R)	ET632204 ET635220 ET398711	CI-5202A CI-5205 CI-5202A CI-5209A CI-5206 CI-5202A	2SC536(F)(G)(H) 2SC711(F)(G)(H) 2SC1641(R)(S)	ET632215 ET621268 ET621224
2SC711(G)(F)	ET598777	CI-5209A CI-5209C	2SC536(G)(H) 2SC945L(K)(P)	ET403391 ET635220
2SC711(H)	ET429748	CI-5203		
2SC1312S(H)	ET242684	CI-5209A	2SC458LG(C)(D)	ET391768
2SC1846(Q)	ET302635	Heat Sink		
2SC2001(K)	ET302501	CI-5203 CI-5209A CI-5211		
2SD234(Y)	ET242370	Heat Sink	2SC1061(C) 2SD313(D)(E)(F)	ET402682 ET522911
2SD571(K)	ET208012	CI-5202A CI-5206	2SC1384(S)(R) 2SD438(E)(F)	ET300632 ET319857
2SD667(C)(D)	ET303895	CI-5206	2SC1214(C)(D)	ET302495
2SK68(L)(M)	ET304169	CI-5205	2SK117(G)(R)	ET303697
2SK68A(Special)	ET302466	CI-5202A	2SK117 (Special)	ET302465
CR-713B	EI301463	CI-3202A		
M53200P	EI430661	CI-5209A	TD3400 SN7400N	EI302686 EI633982
M53202P	EI633960	CI-5209A	SN7402N	EI634083
M53204P	EI573840	CI-5209A	TD3404AP SN7404N	EI302682 EI302681
M53220P	EI592198	CI-5209A	SN7420N	EI302683
TA-7139P	EI302623	CI-5203		

Original Parts			Interchangeable Parts	
Description	Parts No.	Utilizing P.C Board	Description	Parts No.
μPC1023H	EI669666	CI-5203		
IS2473VE	ED560913	CI-5202A CI-5205 CI-5206 CI-5209A/C CI-5211	1S1588 1SS53	ED557447 ED302379
IN34A	ED219464	CI-5202A CI-5205 CI-5209A	1N60 1S188AM	ED428264 ED562386
IN60	ED619784	CI-5209A	1S188AM 1N34A	ED562386 ED219464
WZ-054	ED303034	CI-5211	05Z-5.6L	ED303036
SIQB20 0.6A 200V(RE D)	ED249581	CI-5206	SIQB10 0.6A 100V(BLK)	ED284095
10D05	ED494583	CI-5206	GP08A	ED302641
10D1	ED224526	CI-5206	GP08B	ED302640
05Z-5.6U	ED303155	CI-5206	WZ-059	ED304245
05Z-22U	ED303156	CI-5206	XZ-225	ED304244
RD-4.3E(B)	ED302643	CI-5206	MZ-305A	ED302639
WZ-120	ED510772	CI-5206	MZ-312B	ED302637
XZ-147	ED304243	CI-5206		
GL-32PG	ED283138	CI-5202C		

INDEX

Parts No.	Ref. No. & Symbol No.	Parts No.	Ref. No. & Symbol No.	Parts No.	Ref. No. & Symbol No.	Parts No.	Ref. No. & Symbol No.	Parts No.	Ref. No. & Symbol No.
ZS447840	9-7	ZS670004	2-15	ZW290283	10-22	ZW591265	2-17		
ZS460440	6-10	ZS691277	11-19	ZW290294	11-12x	ZW609311	5-22		
ZS462802	11-24x	ZW231030	10-7	ZW302085	8-12	ZW659171	10-25x		
ZS464692	2-5	ZW259367	6-13	ZW302086	8-13	ZW691266	11-18		
ZS465298	6-9	ZW259571	11-23x	ZW302401	6-31	ZW699052	2-6		
ZS487091	2-18	ZW259942	6-46	ZW302679	8-14				
ZS522180	2-8	ZW270088	4-16	ZW302680	8-15				
ZS537085	6-14	ZW270088	5-10	ZW303680	6-35				
ZS537085	6-29	ZW270088	6-49	ZW305593	5-28x				
ZS558101	6-41x	ZW270101	4-24x	ZW305595	10-26x				
ZS592378	(3)-5	ZW270101	5-11	ZW318014	3-8				
ZS592378	5-30x	ZW273666	2-21	ZW391397	6-17				
ZS592378	5-41	ZW273756	5-5	ZW391397	10-11				
ZS592402	4-11	ZW273756	8-29x	ZW450753	10-21				
ZS608106	6-7	ZW273802	8-37x	ZW452395	2-25				
ZS608174	3-7	ZW273914	8-36	ZW474592	10-10				
ZS608220	6-53	ZW282407	5-9	ZW550642	4-20				
ZS608275	6-24	ZW290283	4-13	ZW550697	6-52				
ZS669104	2-24	ZW290283	5-17	ZW589893	10-16				
ZS669104	4-9	ZW290283	6-5	ZW590207	10-6x				

SECTION 3

SCHEMATIC DIAGRAM

1. GXC-570DII SCHEMATIC DIAGRAM 1560606A
2. GXC-570DII AMP SCHEMATIC DIAGRAM 1560607A

2) SYS. CON P.C BOARD CI-5209A (Top Side)

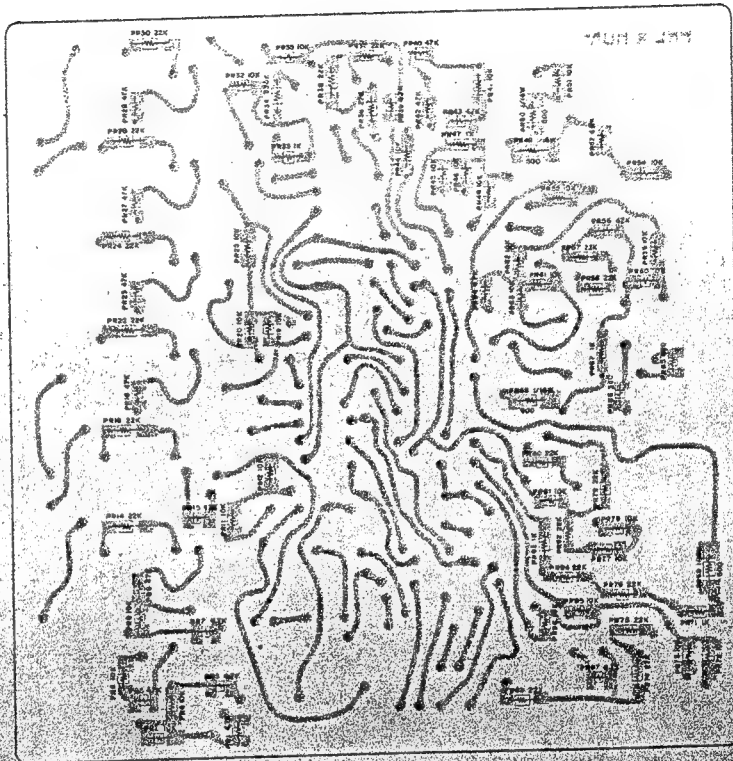

TA7139

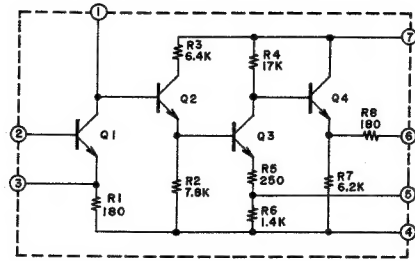

μPC1023H

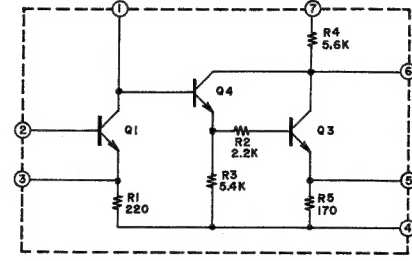

M53200P

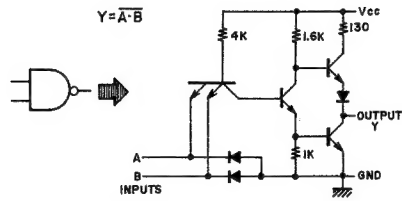
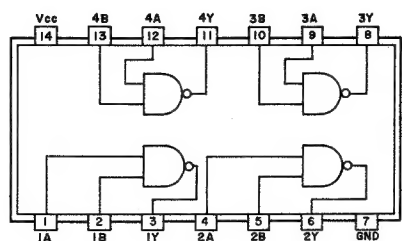

M53220P

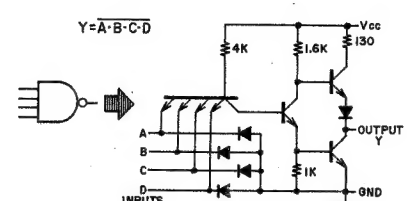
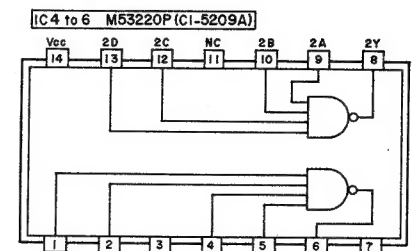

M53202P

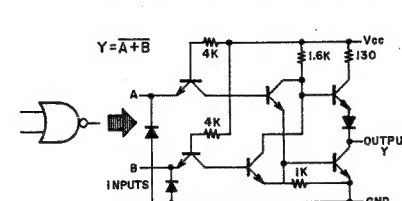
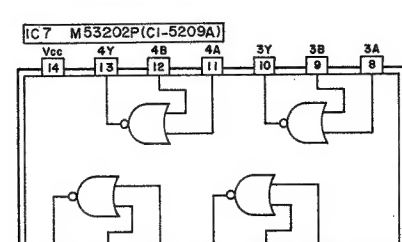

M53204P

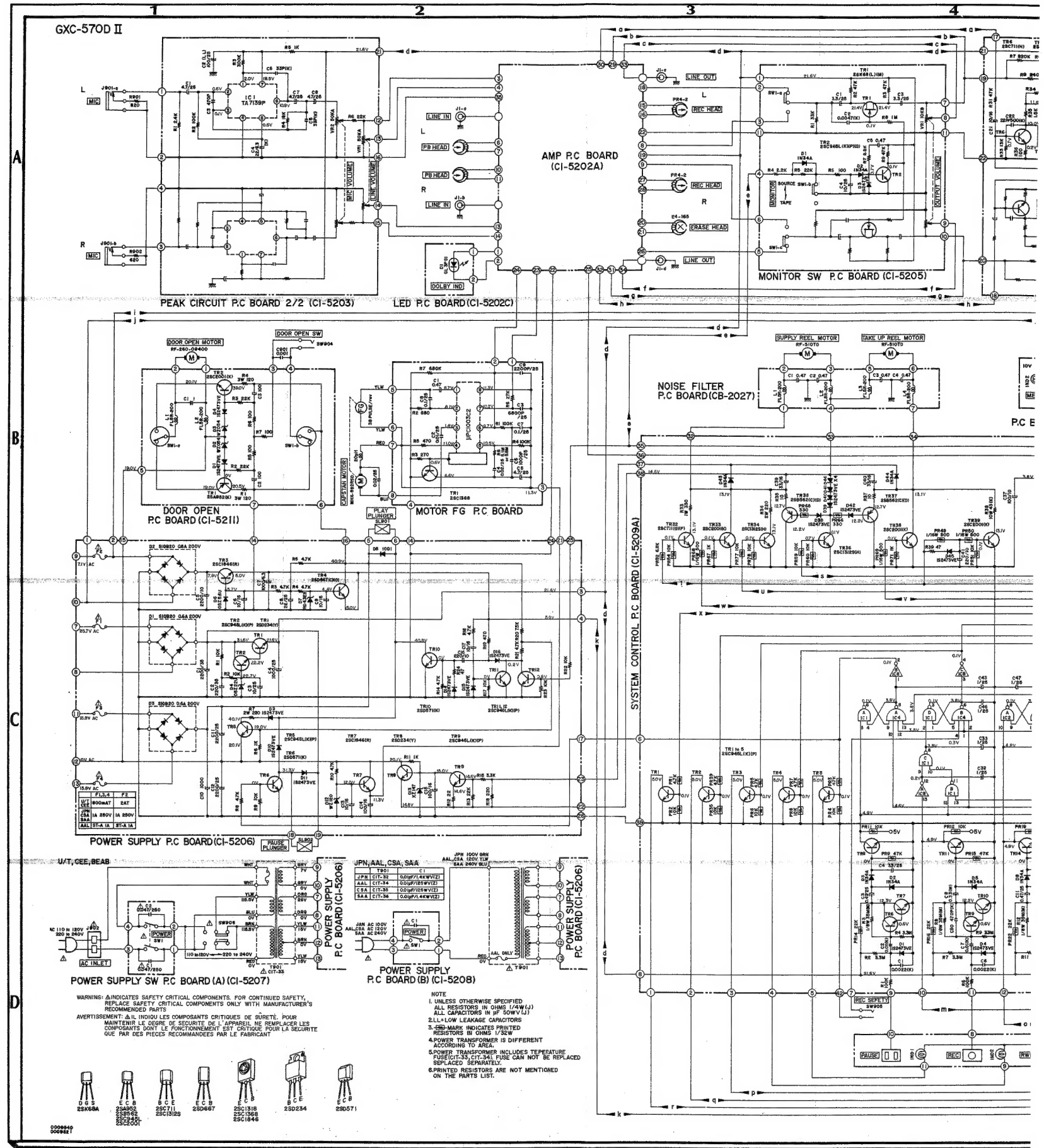
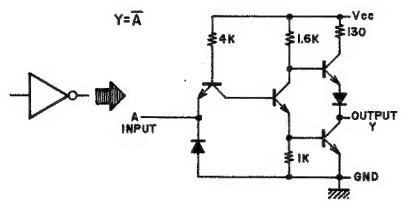
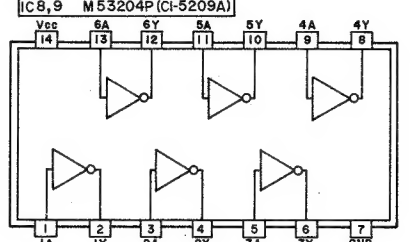

GXC-570D II

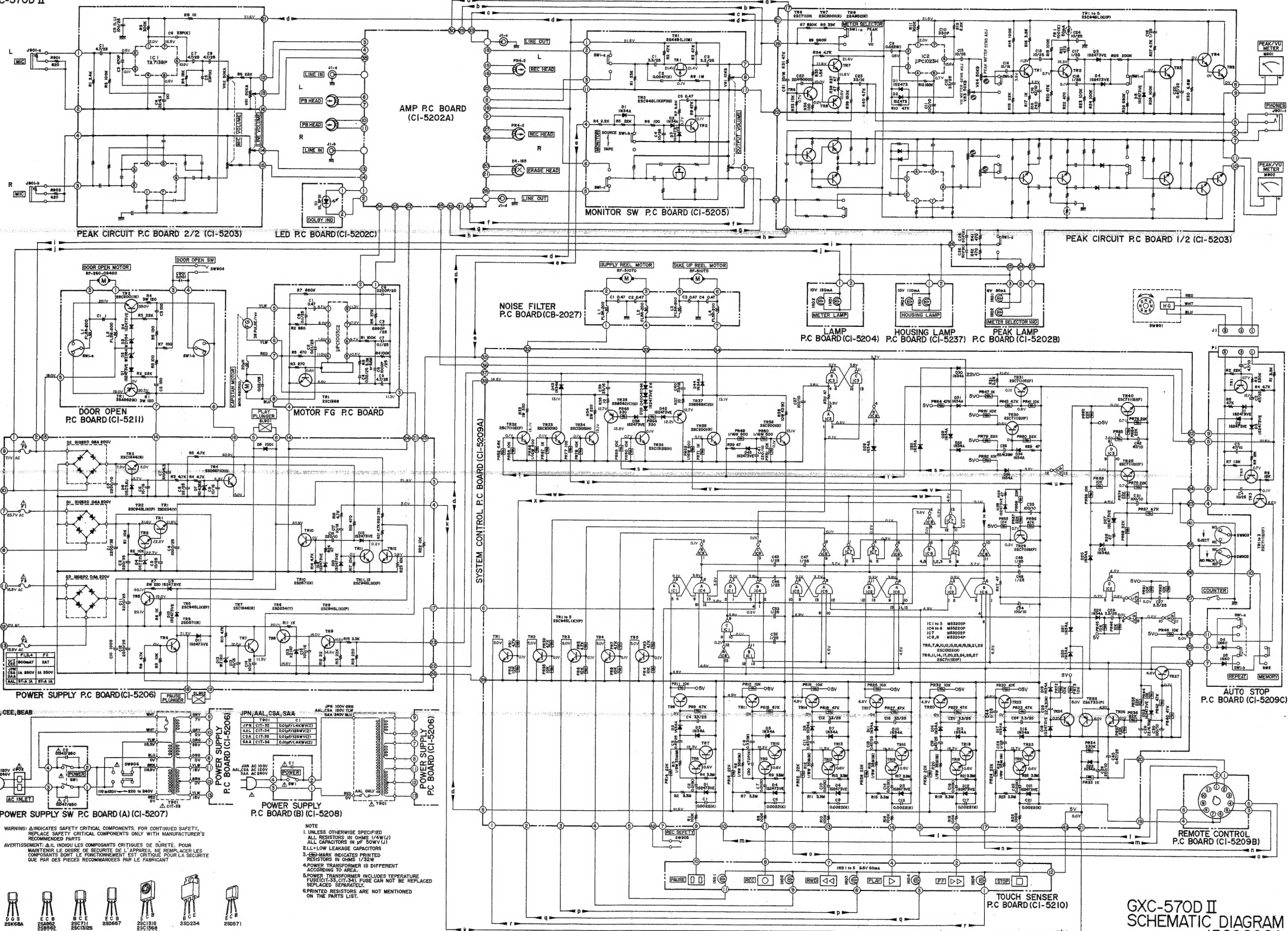

WARNING: Δ INDICATES SAFETY CRITICAL COMPONENTS. FOR CONTINUED SAFETY, REPLACE SAFETY CRITICAL COMPONENTS ONLY WITH MANUFACTURER'S RECOMMENDED PARTS.
 AVERTISSEMENT: Δ IL INDIQUE LES COMPOSANTS CRITIQUES DE SÛRETÉ. POUR MAINTENIR LE NIVEAU DE SÛRETÉ DE L'APPAREIL, NE REMPLACEZ LES COMPOSANTS DONT LE FONCTIONNEMENT EST CRITIQUE POUR LA SÛRETÉ QUE PAR DES PIÈCES RECOMMANDÉES PAR LE FABRICANT.

NOTE
 1. UNLESS OTHERWISE SPECIFIED ALL RESISTORS IN OHMS (1/4W, 1/2W)
 ALL CAPACITORS IN μF (50V)
 2. L-LOW LEAKAGE CAPACITORS
 3. ○-MARK INDICATES PRINTED RESISTORS IN OHMS 1/25W
 4. POWER TRANSFORMER IS DIFFERENT ACCORDING TO AREA
 5. POWER TRANSFORMER INCLUDES TEMPERATURE FUSE (T-33, CTT-34) FUSE CAN NOT BE REPLACED SEPARATELY.
 6. PRINTED RESISTORS ARE NOT MENTIONED ON THE PARTS LIST.

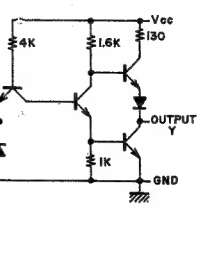
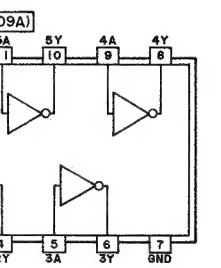
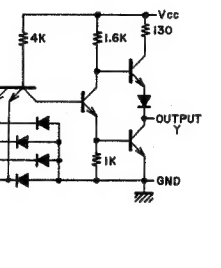
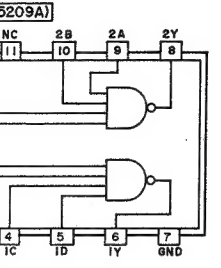
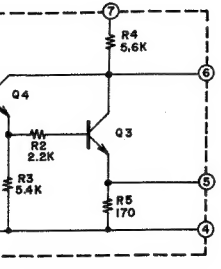
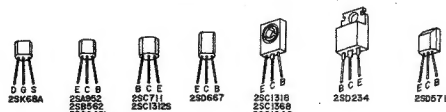

GXC-570D II
 SCHEMATIC DIAGRAM
 NO.2-1 1560606A

CR-713B

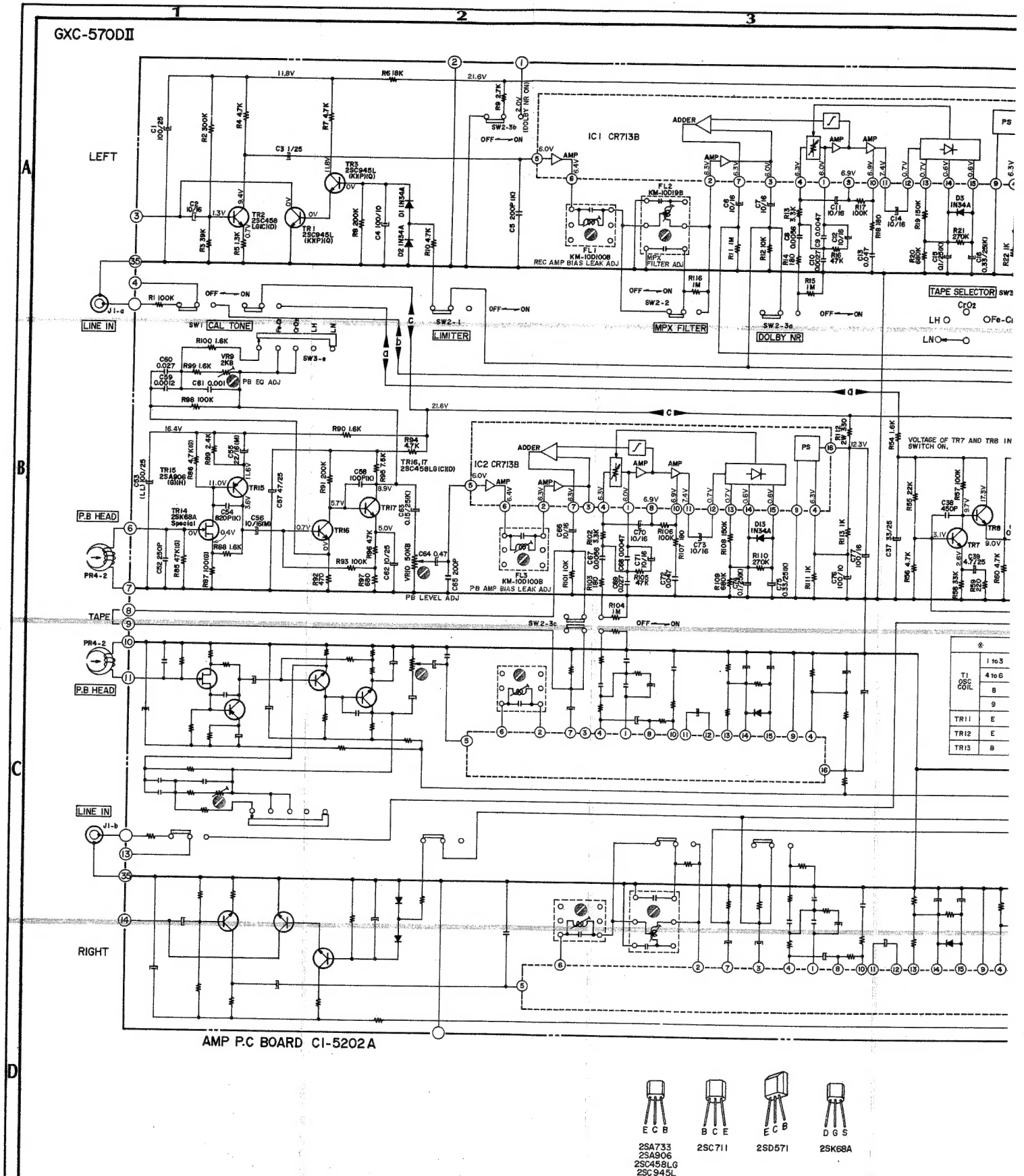
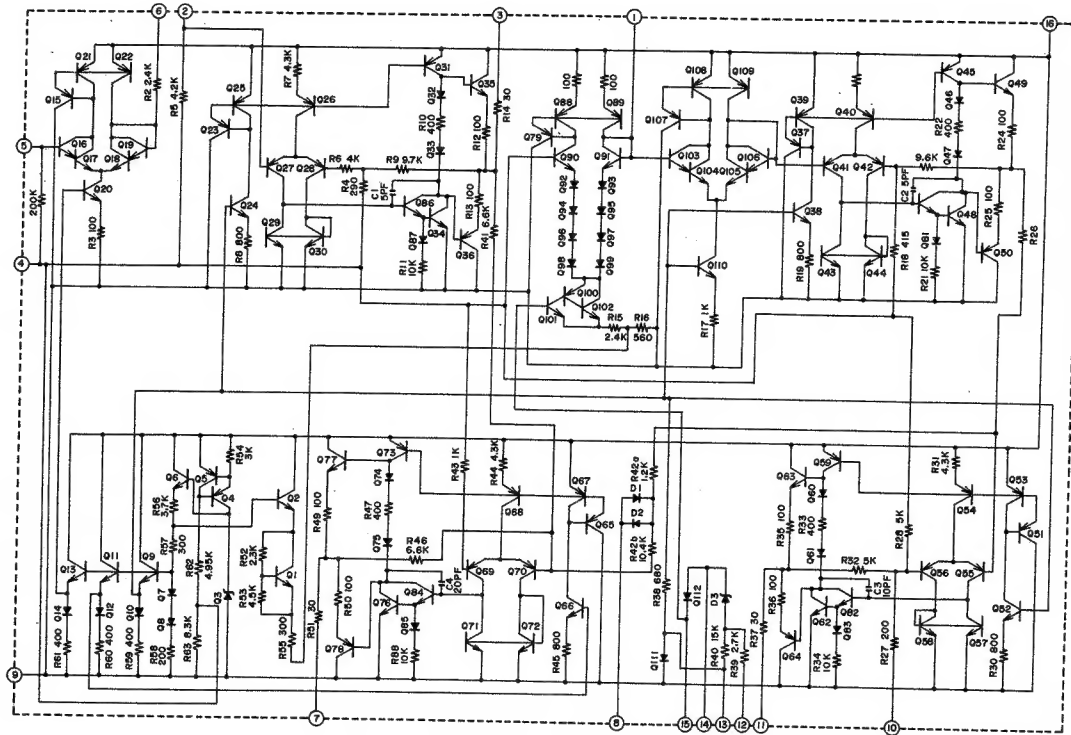

000853H

GXC-570DII

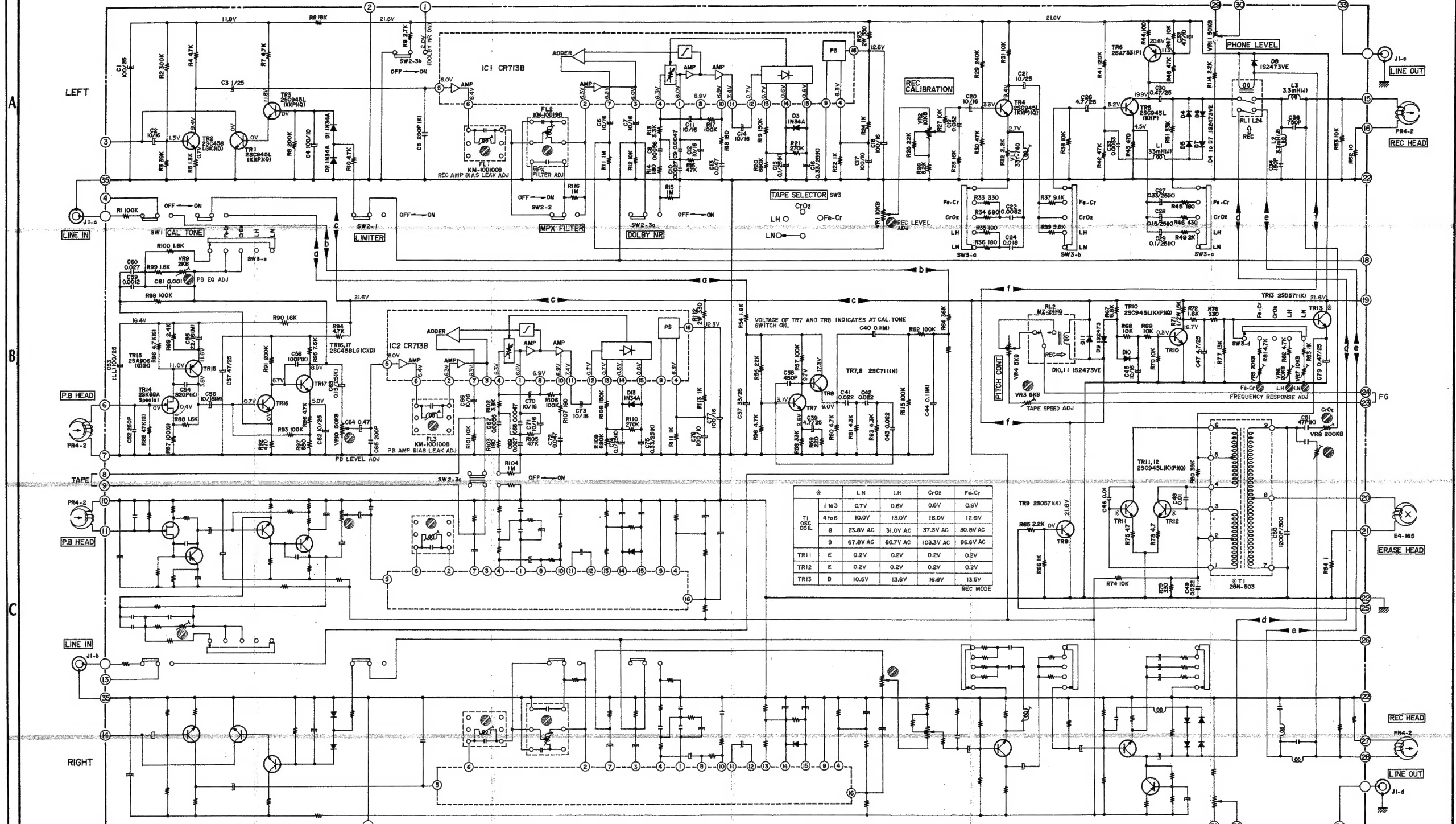

AMP P.C BOARD CI-5202A

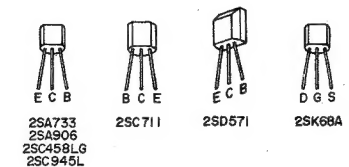

GXC-570DII AMP
SCHEMATIC DIAGRAM
NO. 2-2 1560607A
2C