

AKAI SERVICE MANUAL

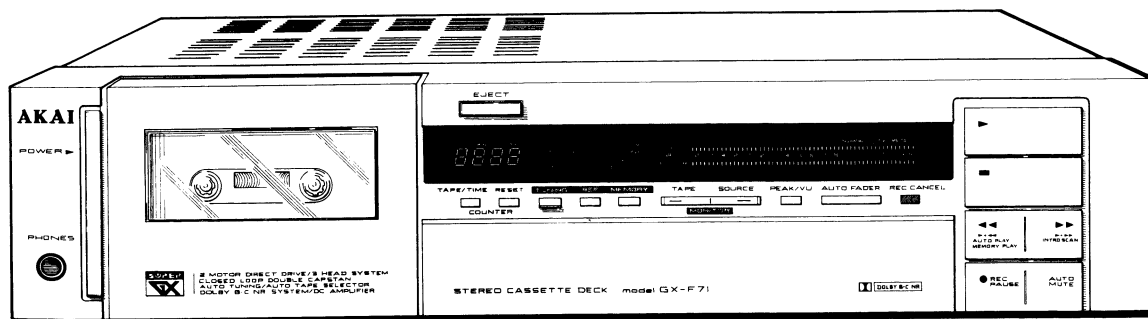
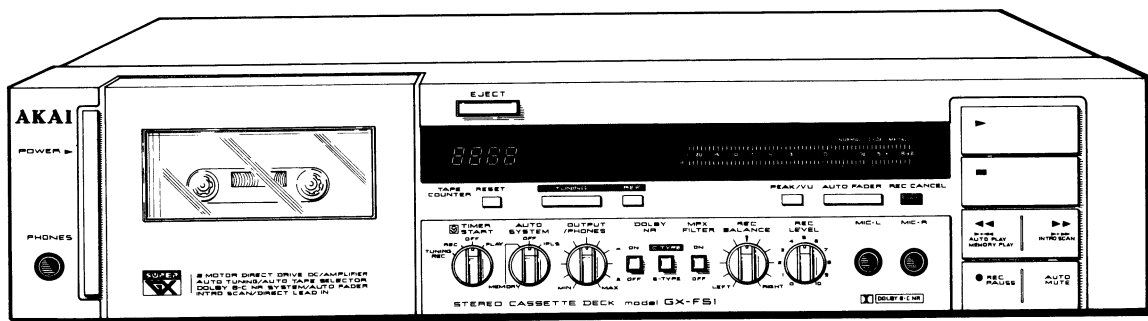
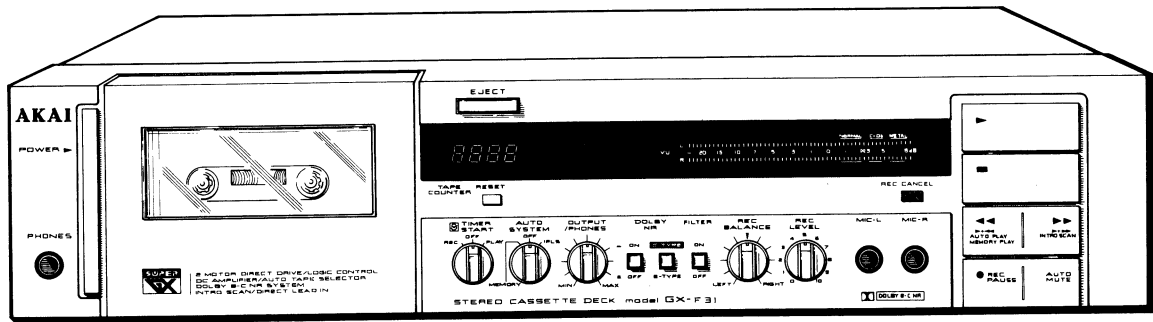

STEREO CASSETTE DECK

MODEL **GX-F31**

MODEL **GX-F51**

MODEL **GX-F71**



GX-F31



GX-F51



GX-F71

STEREO CASSETTE DECK

GX-F31
GX-F51
MODEL **GX-F71**

THIS MANUAL IS APPLICABLE TO BOTH SILVER
AND PEARL SHADOW PANEL MODELS

- SECTION 1** **CIRCUIT OPERATION DESCRIPTION**
SECTION 2 **MODEL GX-F31 SERVICE MANUAL**
SECTION 3 **MODEL GX-F51 SERVICE MANUAL**
SECTION 4 **MODEL GX-F71 SERVICE MANUAL**
SECTION 5 **PARTS LIST**
SECTION 6 **SCHEMATIC DIAGRAM**
-

SAFETY INSTRUCTIONS

SAFETY CHECK AFTER SERVICING

Confirm the specified insulation resistance between power cord plug prongs and externally exposed parts of the set is greater than 10 Mohms, but for equipment with external antenna terminals (tuner, receiver, etc.) and is intended for [C] or [A], specified insulation resistance should be more than 2.2 Mohms (ground terminals, microphone jacks, headphone jacks, line-in-out jacks etc.)

PRECAUTIONS DURING SERVICING

1. Parts identified by the \triangle symbol parts are critical for safety.
Replace only with parts number specified.
2. In addition to safety, other parts and assemblies are specified for conformance with such regulations as those applying to spurious radiation. These must also be replaced only with specified replacements.
Examples: RF converters, tuner units, antenna selector switches, RF cables, noise blocking capacitors, noise blocking filters, etc.
3. Use specified internal wiring. Note especially:
 - 1) Wires covered with PVC tubing
 - 2) Double insulated wires
 - 3) High voltage leads
4. Use specified insulating materials for hazardous live parts. Note especially:
 - 1) Insulation Tape
 - 2) PVC tubing
 - 3) Spacers (Insulating Barriers)
 - 4) Insulation sheets for transistors
5. When replacing AC primary side components (transformers, power cords, noise blocking capacitors, etc.), wrap ends of wires securely about the terminals before soldering.

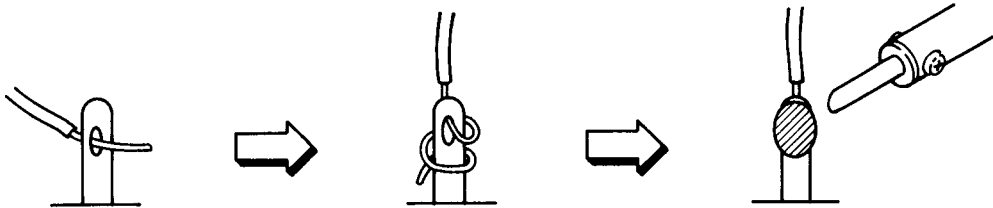

6. Observe that wires do not contact heat producing parts (heatsinks, oxide metal film resistors, fusible resistors, etc.).
 7. Check that replaced wires do not contact sharp edged or pointed parts.
 8. Also check areas surrounding repaired locations.
 9. Use care that foreign objects (screws, solder droplets, etc.) do not remain inside the set.
-

SECTION 1

CIRCUIT OPERATION DESCRIPTION

TABLE OF CONTENTS

I.	DESCRIPTION OF GX-F71 AUTO TUNING FUNCTION	1- 2
	1. GX-F71 AUTO TUNING BLOCK DIAGRAM	1- 2
	2. DESCRIPTION OF GX-F71 AUTO TUNING FUNCTION	1- 3
	3. INPUT OUTPUT MODES OF EACH TERMINAL OF AUTO TUNING CPU (M58841-600P)	1- 4
II.	GX-F71 SYSCON CIRCUIT FUNCTIONS	1- 5
	1. GX-F71 SYSCON BLOCK DIAGRAM	1- 5
	2. MEANING EACH TERMINAL OF CPU (LM6402 H063)	1- 6
	3. CONNECTION OF EACH TERMINAL OF IC (LC7800) FOR EXPANDING GX-F71 INPUT PORT	1- 8
III.	DESCRIPTION OF GX-F51 CIRCUIT	1- 9
	1. OUTLINE OF GX-F51 AUTO TUNING SYSTEM	1- 9
	2. GX-F51 AUTO TUNING BLOCK DIAGRAM	1- 9
	3. GX-F51 AUTO TUNING FUNCTION DIAGRAM	1-10
	4. GX-F51 PRE AMP BLOCK DIAGRAM	1-11
IV.	AUTO FADER CIRCUIT	1-12
V.	CAM MOTOR DRIVE CIRCUIT	1-13
VI.	REEL MOTOR DRIVE CIRCUIT	1-14

I. DESCRIPTION OF GX-F71 AUTO TUNING FUNCTION

1. GX-F71 AUTO TUNING BLOCK DIAGRAM

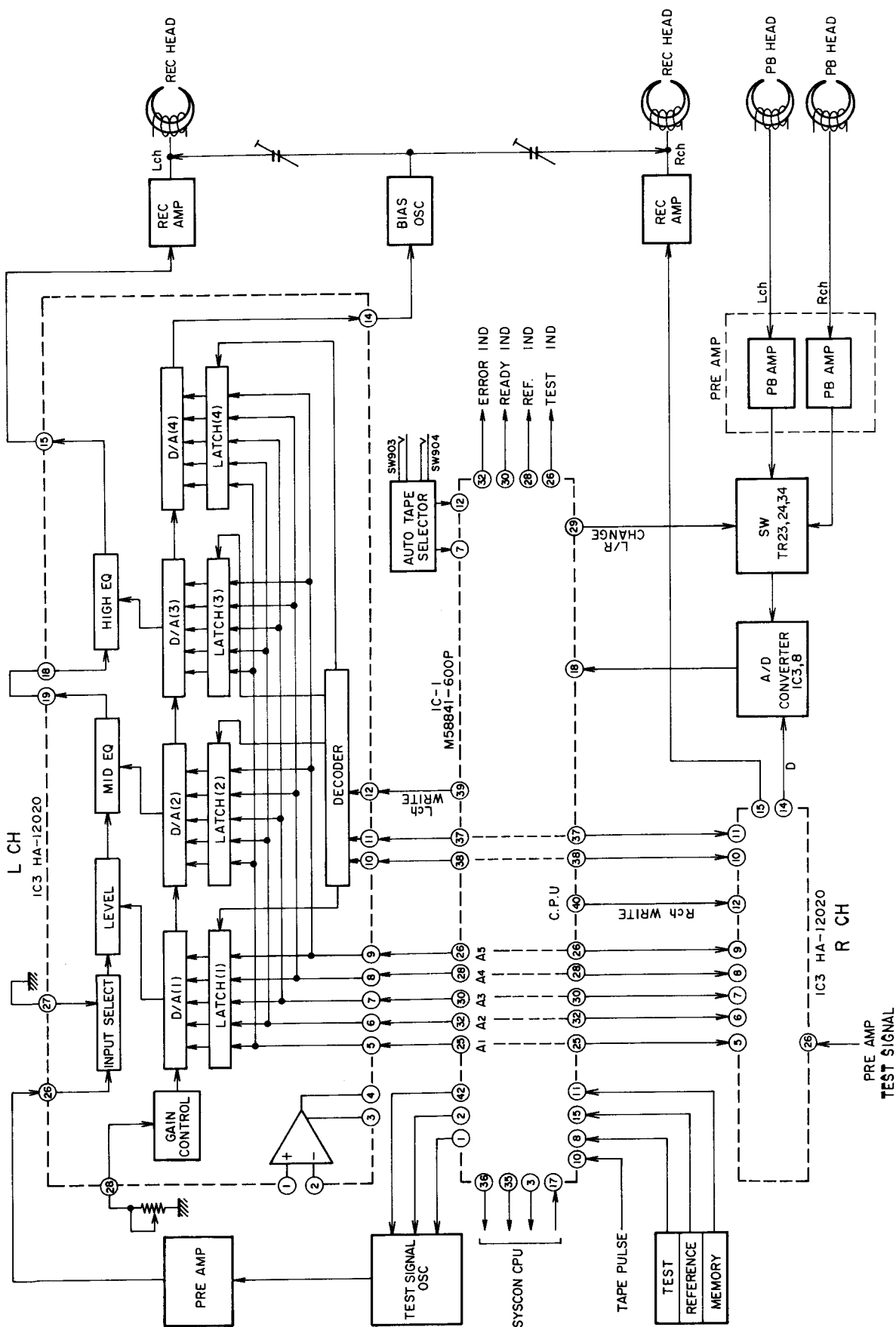

Fig. 1 Auto Tuning Block Diagram

2. DESCRIPTION OF GX-F71 AUTO TUNING FUNCTION

1) When, after the power is "on", the cassette-pack is set and the test key is set to "on" position, terminals ③, ③⑤ and ③⑥, of tuning CPU (IC1) becomes "L", "L" and "H", respectively, system control (IC8) is set to FF mode and the counter quickly winds 64 counts. Then, ③, ③⑤ and ③⑥ becomes "H", "L" and "L", respectively, the syscon CPU is set to Rec/Play mode and the bias circuit oscillates.

2) Coarse adjustment of level

Terminals ①, ② and ④② of tuning CPU (IC1) becomes "L", "L", and "L" respectively when CPU is set to Rec/Play mode and the test signal OSC oscillates 1 kHz. This output passes through the PRE-Amp circuit, enters terminal ②⑥ of IC3 as the test signal and is output from ①⑤. Then, the signal passes through Rec Amp, mixed with the bias and is applied to the REC head.

The 1 kHz signal recorded on the tape passes through the PB Head and PB Amp, Lch and Rch signals are selected by the switch circuit of TR23, 24 and 34 (Tuning P.C Board), A/D converted at IC8 and IC3 (Part) and, then, input into IC1 ①⑧ as a PB signal level detection signal.

Under this condition, the signal level of 1 kHz is positively half-wave rectified by IC8 and charged to C35 (10 μ /16V) and applied to IC3 ②, but 5 bits (32 steps) of stair step waveform signal is applied to the terminal, IC3 ①, and when the level of IC3 ① becomes equal to that of terminal ②, the output is changed from "L" to "H" while the collector of TR49 is trailed from "H" to "L". PB signal level is detected by this trailing. At this time, the data outputs at terminals ②⑤, ②⑥, ③⑧, ③⑩ and ③② of IC1 are written as level data in latch (1) of IC3. This operation is performed once for Lch and Rch, respectively.

3) Bias adjustment

When the coarse level adjustment is completed, a step form wave (up direction) is output from IC3 (Lch) ①④ terminal and controls IC7 ⑥ → IC7 ④ → TR19, thus changing the amount of bias.

As the bias is changed, the signal of 1 kHz from the test signal circuit is recorded on the tape as

a signal of changed level and accordingly the PB level is changed. Since these changes are in proportion to the bias change, the PB level is detected.

The bias is adjusted twice; in up direction and down direction, therefore, the mean value added +4 step is written as bias data into the latch of IC3 (Lch) as the most suitable bias amount. Only Rch is subjected to bias adjustment.

4) 1 kHz level adjustment

When the bias adjustment is completed, the 1 kHz level adjustment is made in the same manner as the coarse level adjustment.

5) 7 kHz EQ adjustment

When the 1 kHz level adjustment is completed, terminals ①, ② and ④② of IC1 become "L", "H" and "L", respectively and the test signal OSC circuit oscillates 7 kHz. The inner D/A (2) and latch (2) of IC3 are controlled by the 5 bit signal from CPU (IC1) so that the 7 kHz PB level is adjusted to the same level as the 1 kHz reference. When the 7 kHz level is adjusted to the same level of 1 kHz reference, the data are written into latch (2).

The 7 kHz EQ adjustment is made once in Lch and Rch, respectively.

6) 13 kHz EQ adjustment



After 7 kHz EQ is adjusted, terminals ①, ② and ④② of IC1 become "H", "H" and "L", respectively and the test signal OSC circuit oscillates 13 kHz and when the PB signal level of 13 kHz is adjusted to the same level as the 1 kHz reference level, the data of 13 kHz EQ are written into latch (3) of IC3.

The adjustments from 4) to 6) are repeated three times.

7) When the above tuning is completed, terminals ③, ③⑤ and ③⑥ of IC1 become "L", "H" and "H", respectively and the syscon CPU is set to RWD mode.

In case of TUNING REC, the tape counter is rewound to "0" and in case where Rec/Play and Timer Start SW are off, REW is changed to REC/PAUSE at "23" on the counter.

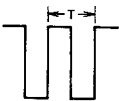
3. INPUT OUTPUT MODES OF EACH TERMINAL OF AUTO TUNING CPU (M58841-600P)

PIN NO.	NAME	FUNCTION																												
1 2	FRQ I FRQ II	TEST SIGNAL OSC FREQUENCY CONTROL <table border="1" style="margin-left: 20px;"> <tr> <td>①</td> <td>L</td> <td>L</td> <td>H</td> </tr> <tr> <td>②</td> <td>L</td> <td>H</td> <td>H</td> </tr> <tr> <td>OSC</td> <td>1 kHz</td> <td>7 kHz</td> <td>13 kHz</td> </tr> </table>	①	L	L	H	②	L	H	H	OSC	1 kHz	7 kHz	13 kHz																
①	L	L	H																											
②	L	H	H																											
OSC	1 kHz	7 kHz	13 kHz																											
42	OSC START	L: OSC ON H: OSC OFF																												
35 36 3	MECHACON I MECHACON II MECHACON III	<table border="1" style="margin-left: 20px;"> <tr> <td>③⑤</td> <td>L</td> <td>H</td> <td>L</td> <td>H</td> <td>L</td> <td>H</td> </tr> <tr> <td>③⑥</td> <td>L</td> <td>L</td> <td>H</td> <td>H</td> <td>L</td> <td>L</td> </tr> <tr> <td>③</td> <td>L</td> <td>L</td> <td>L</td> <td>L</td> <td>H</td> <td>H</td> </tr> <tr> <td></td> <td>NON OPERATION</td> <td>STOP</td> <td>FF</td> <td>REW</td> <td>REC/PLAY</td> <td>REC/PAUSE</td> </tr> </table>	③⑤	L	H	L	H	L	H	③⑥	L	L	H	H	L	L	③	L	L	L	L	H	H		NON OPERATION	STOP	FF	REW	REC/PLAY	REC/PAUSE
③⑤	L	H	L	H	L	H																								
③⑥	L	L	H	H	L	L																								
③	L	L	L	L	H	H																								
	NON OPERATION	STOP	FF	REW	REC/PLAY	REC/PAUSE																								
12 7	TAPE POSITION I TAPE POSITION II	<table border="1" style="margin-left: 20px;"> <tr> <td>⑫</td> <td>H</td> <td>H</td> <td>L</td> </tr> <tr> <td>⑦</td> <td>H</td> <td>L</td> <td>L</td> </tr> <tr> <td>POSITION</td> <td>NORMAL</td> <td>CrO₂</td> <td>METAL</td> </tr> </table>	⑫	H	H	L	⑦	H	L	L	POSITION	NORMAL	CrO ₂	METAL																
⑫	H	H	L																											
⑦	H	L	L																											
POSITION	NORMAL	CrO ₂	METAL																											
8	TEST START KEY	Started by "L" input																												
11	MEMORY KEY	Memory output by "L" input																												
15	REFERENCE KEY	Reference output by "L" input																												
10	COUNTER PULSE	 "T" means one full counts																												
16	TIMER	With "L" input, Tuning REC is feasible but with "H", it is not feasible.																												
17	TUNING SAFE	With "H" input, tuning is feasible, but with "L" input, tuning is not feasible. If the "H" input enters during tuning, the tuning stops.																												
18	PB DETECT	Judged by the trailing edge																												
25 32 30 28 26	DATA I (A ₁) DATA II (A ₂) DATA III (A ₃) DATA IV (A ₄) DATA V (A ₅)	"H" output is used as data output																												
27	IND OUT	The "H" synchronized with one of Data II – V is output to light the tuning indicator.																												
29	Lch/Rch CHANGE	"H" output → Lch. "L" output → Rch.																												
41	TUNING TEST	While testing → "H" output. While test is off → "L".																												
37 38	LATCH SELECT I LATCH SELECT II	Latch of HA12020 is selected <table border="1" style="margin-left: 20px;"> <tr> <td>③⑦</td> <td>L</td> <td>H</td> <td>L</td> <td>H</td> </tr> <tr> <td>③⑧</td> <td>L</td> <td>L</td> <td>H</td> <td>H</td> </tr> <tr> <td>DATA</td> <td>1 kHz Data</td> <td>7 kHz Data</td> <td>13 kHz Data</td> <td>Bias, A/D Data</td> </tr> </table>	③⑦	L	H	L	H	③⑧	L	L	H	H	DATA	1 kHz Data	7 kHz Data	13 kHz Data	Bias, A/D Data													
③⑦	L	H	L	H																										
③⑧	L	L	H	H																										
DATA	1 kHz Data	7 kHz Data	13 kHz Data	Bias, A/D Data																										
39 40	Lch WRITE Rch WRITE	 Output pulse. Latch data at the edge of rise.																												
31	HOLD RESET	When "H" output is being made, reset is OK. It is "H" while test is off.																												

II. GX-F71 SYSCON CIRCUIT FUNCTIONS

1. GX-F71 SYSCON BLOCK DIAGRAM

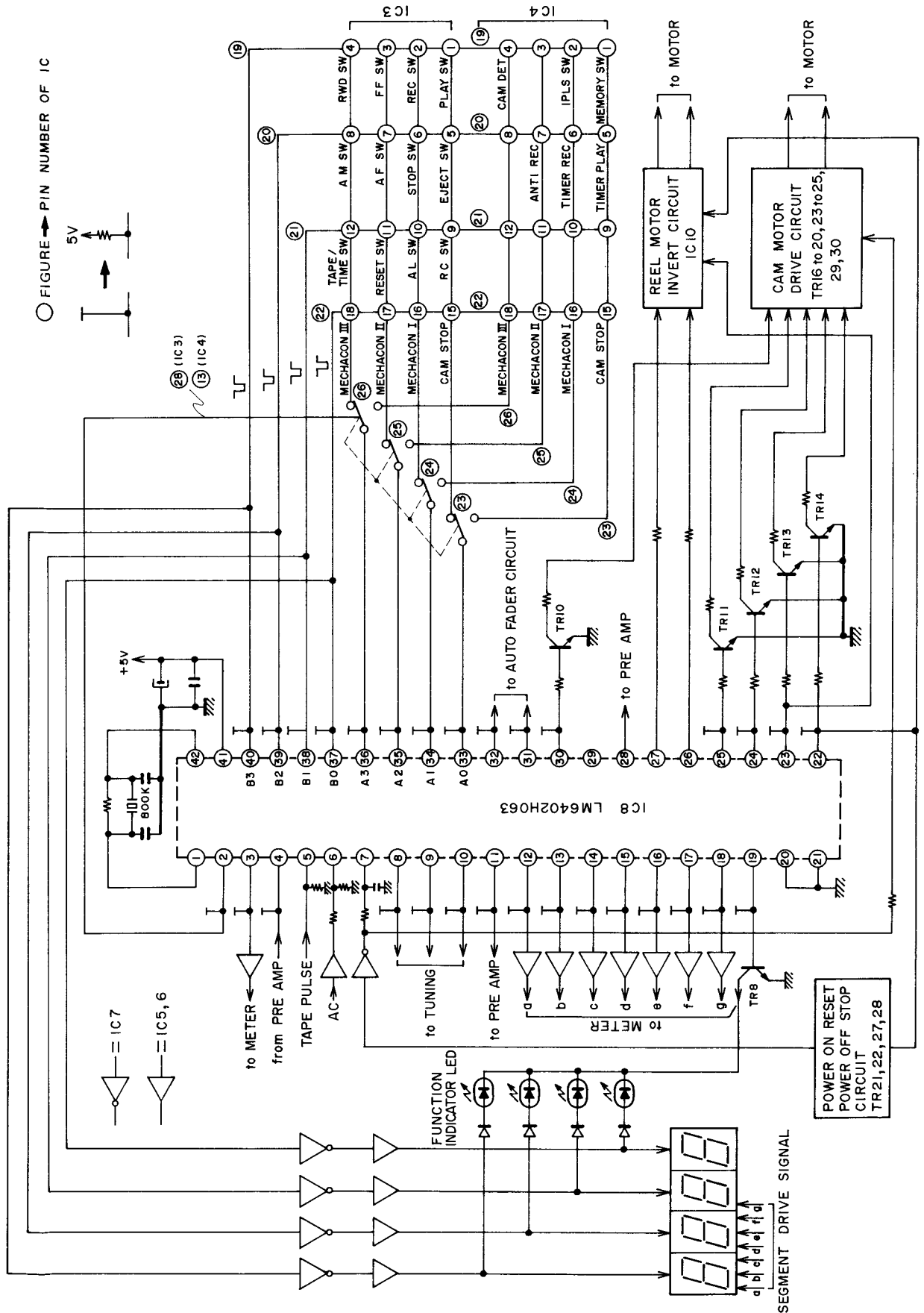
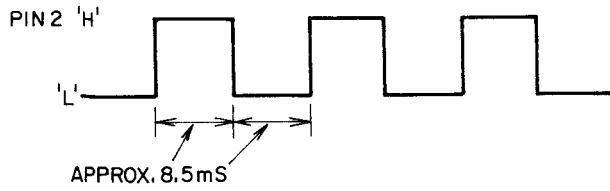

Fig. 2 Syscon Block Diagram

2. MEANING EACH TERMINAL OF CPU (LM6402 H063)

PIN NO.	SYMBOL	MEANING	
1	XTAL	Input of crystal oscillator	
2*	C0	Input port selection storobe	
3	C1	Colon, MIN/SEC is lit, turned on when level is "H".	
4	C2	Between musics signal input. "H" while between musics.	
5	C3	Tape pulse input	
6	$\overline{\text{INT}}$	Terminal for interruption. Power supply frequency input.	
7	$\overline{\text{RES}}$	Reset terminal. When power is on, reset when it is "L".	
8	D0	Mecha stop terminal. Stops when it is "L".	
9	D1	BIAS OSC control terminal. Stop when it is "H".	
10	D2	REC MUTE terminal. MUTE when it is "H".	
11	D3	PB MUTE terminal. MUTE when it is "H".	
12*	E0	Segment LED Drive a	
13*	E1	Segment LED Drive b	
14*	E2	Segment LED Drive c	
15*	E3	Segment LED Drive d	
16*	F0	Segment LED Drive e	
17*	F1	Segment LED Drive f	
18*	F2	Segment LED Drive g	
19	F3	Strobe signal for driving function indication LED. Synchronized LED is lit. Refer to B0 ~ B3.	
20	GND	Connect to ground	
21	GND	Connect to ground	
22	G0	Cam motor drive terminal. When played → "H"	
23	G1	Cam motor drive terminal. When stopped → "H"	
24	G2	Cam motor drive terminal. When searching → "H" (when CUE)	
25	G3	Cam motor drive terminal. When FAST → "H" (when FF, REW)	
26*	H0	REEL M. reverse turn terminal. When REW → "H". Prevents tape slackening.	
27	H1	REEL M. normal turn terminal. When FF, PLAY → "H".	
28	H2	When PLAY → "H". When REC → "L".	
29	H3	No connection	
30	I0	Cam motor drive terminal. When EJECT → "H".	
31	I1	AUTO FADE IN. → "L" active	
32	I2	AUTO FADE OUT. → "L" active	
33*	A0	} Data input	
34*	A1		
35*	A2		
36*	A3		
37*	B0	} Data selection strobe signal output. 4 digits drive	REC LED Drive
38*	B1		PLAY LED Drive
39*	B2		REW LED Drive
40*	B3		FF LED Drive
41	VCC	+5V	
42	EXTAL	Input of crystal oscillator	

* Please refer to Fig. of this terminals.



WHEN IT IS 'H', IC 4 IS SELECTED (SERCH)
 WHEN IT IS 'L', IC 3 IS SELECTED (SERCH)

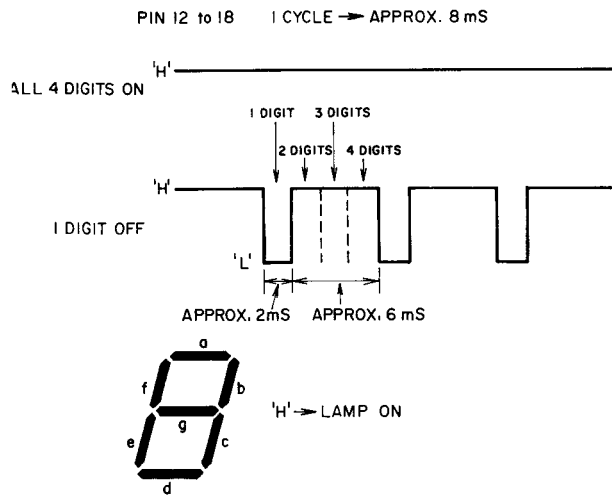
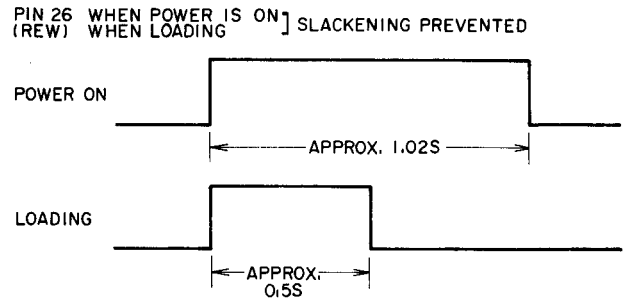

PIN 37 to 40 STROBE SIGNAL

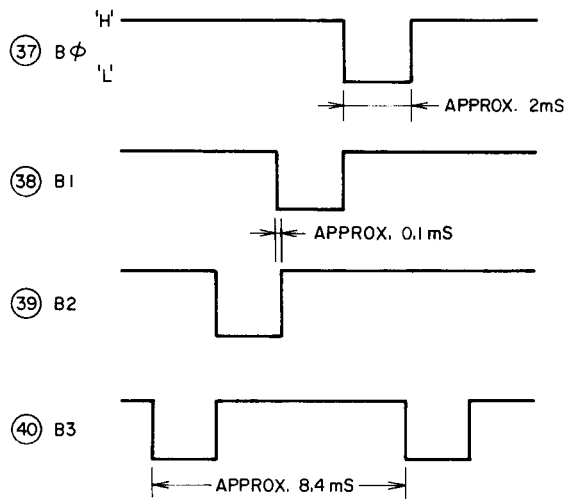

Syscon IC8 Pin ③③ ~ ③⑥ data input waveform

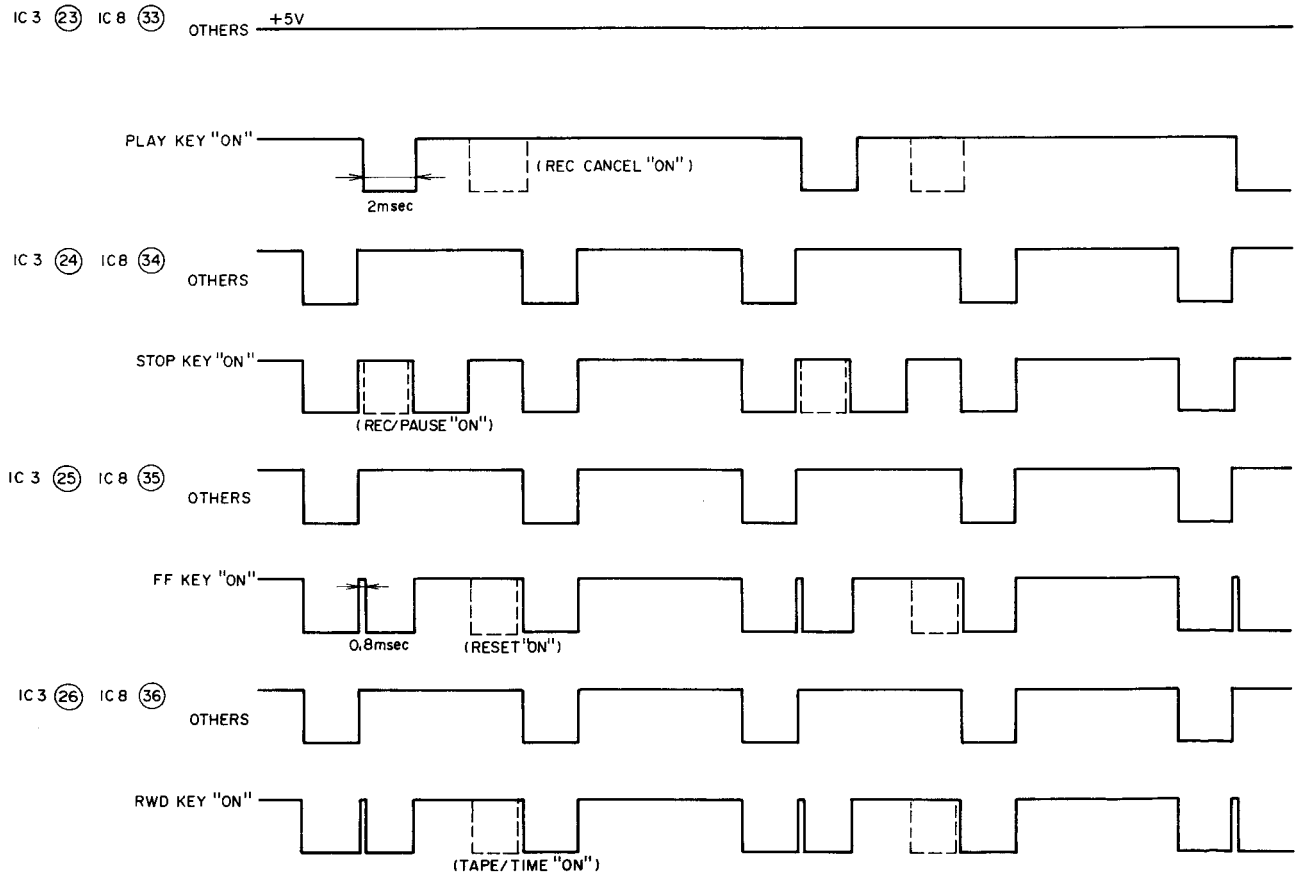

Fig. 3

**3. CONNECTION OF EACH TERMINAL OF IC (LC 7800)
FOR EXPANDING GX-F71 INPUT PORT**

PIN	Items connected to IC3	Items connected to IC4																																				
1	PLAY SW	MEMORY SW																																				
2	REC SW	IPLS SW																																				
3	FF SW	OPEN ("H") (No connection)																																				
4	REW SW	R104 of cam motor drive circuit																																				
5	EJECT SW	TIMER PLAY SW																																				
6	STOP SW	TIMER REC SW																																				
7	AUTO FADER SW	ANTIREC SW																																				
8	AUTO MUTE SW	+5 V (No connection)																																				
9	REC CANCEL SW	+5 V (No connection)																																				
10	AUTO LOADING SW	+5 V (No connection)																																				
11	RESET SW	+5 V (No connection)																																				
12	TAPE/TIME SW	+5 V (No connection)																																				
13	GND	MICON PIN2																																				
14	GND	GND																																				
15	C-stop signal of cam motor drive circuit																																					
16	TUNING MICON PIN 35 (For Mechacontrol)																																					
17	TUNING MICON PIN 36 (Signal)																																					
18	TUNING MICON PIN 3 (When TUNING)																																					
Mechacontrol signal from TUNING MICON																																						
	<table border="1"> <thead> <tr> <th>TUNING MICON PIN</th> <th>SYSCON MICON PIN</th> <th>NON OPERATION</th> <th>STOP</th> <th>FF</th> <th>REW</th> <th>REC/PLAY</th> <th>REC/PAUSE</th> <th>TEST OFF</th> </tr> </thead> <tbody> <tr> <td>35 (O₀) MECHACON I</td> <td>34 (A1)</td> <td>L</td> <td>H</td> <td>L</td> <td>H</td> <td>L</td> <td>H</td> <td>L</td> </tr> <tr> <td>36 (O₁) MECHACON II</td> <td>35 (A2)</td> <td>L</td> <td>L</td> <td>H</td> <td>H</td> <td>L</td> <td>L</td> <td>L</td> </tr> <tr> <td>3 (O₂) MECHACON III</td> <td>36 (A3)</td> <td>L</td> <td>L</td> <td>L</td> <td>L</td> <td>H</td> <td>H</td> <td>L</td> </tr> </tbody> </table>	TUNING MICON PIN	SYSCON MICON PIN	NON OPERATION	STOP	FF	REW	REC/PLAY	REC/PAUSE	TEST OFF	35 (O ₀) MECHACON I	34 (A1)	L	H	L	H	L	H	L	36 (O ₁) MECHACON II	35 (A2)	L	L	H	H	L	L	L	3 (O ₂) MECHACON III	36 (A3)	L	L	L	L	H	H	L	
TUNING MICON PIN	SYSCON MICON PIN	NON OPERATION	STOP	FF	REW	REC/PLAY	REC/PAUSE	TEST OFF																														
35 (O ₀) MECHACON I	34 (A1)	L	H	L	H	L	H	L																														
36 (O ₁) MECHACON II	35 (A2)	L	L	H	H	L	L	L																														
3 (O ₂) MECHACON III	36 (A3)	L	L	L	L	H	H	L																														
19	SYSCON MICON PIN 40 (B3)																																					
20	SYSCON MICON PIN 39 (B2)																																					
21	SYSCON MICON PIN 38 (B1)																																					
22	SYSCON MICON PIN 37 (B0)																																					
23	SYSCON MICON PIN 33 (A0)																																					
24	SYSCON MICON PIN 34 (A1)																																					
25	SYSCON MICON PIN 35 (A2)																																					
26	SYSCON MICON PIN 36 (A3)																																					
27	+5V	+5V																																				
28	MICON PIN 2	+5V																																				

III. DESCRIPTION OF GX-F51 CIRCUIT

1. OUTLINE OF GX-F51 AUTO TUNING SYSTEM

When the test switch is set to STOP position, the microprocessor sets the mode to FF for 64 counts, the leader tape is avoided and REC mode is set.

While changing the bias by variation of 3 bits 8 steps, the standard input of 1 kHz/10 kHz is recorded in one step. When 8 steps are completed, the tape is rewound and the point where the level of 1 kHz is equal to that of 10 kHz is picked up as a bias setting point. If there is no equal point, the same process is repeated and a point with minimum difference between 1 kHz and 10 kHz is picked up as the setting point. The variable range is $\pm 20\%$.

Next 1 kHz signal is record at 8 different levels

(8 steps). Then the tape is played back and the recording sensitivity level is set at the level equal to the reference input level (-20VU). If there is no level equal to the reference input level, recording & playback will be carried out again and the recording sensitivity level will be set at the level closest to the reference input level. The variable range is -3 dB to +4 dB. By changing the bias, frequency characteristics 1 kHz/10 kHz can be adjusted and by setting REC/PB levels, the fluctuation of frequency characteristics can be absorbed when, for instance, using Dolby-C type, etc. The contents of tuning is not changed unless REF is depressed or the tuning is repeated again.

GX-F51 should set nearest to REF without indication of errors.

2. GX-F51 AUTO TUNING BLOCK DIAGRAM

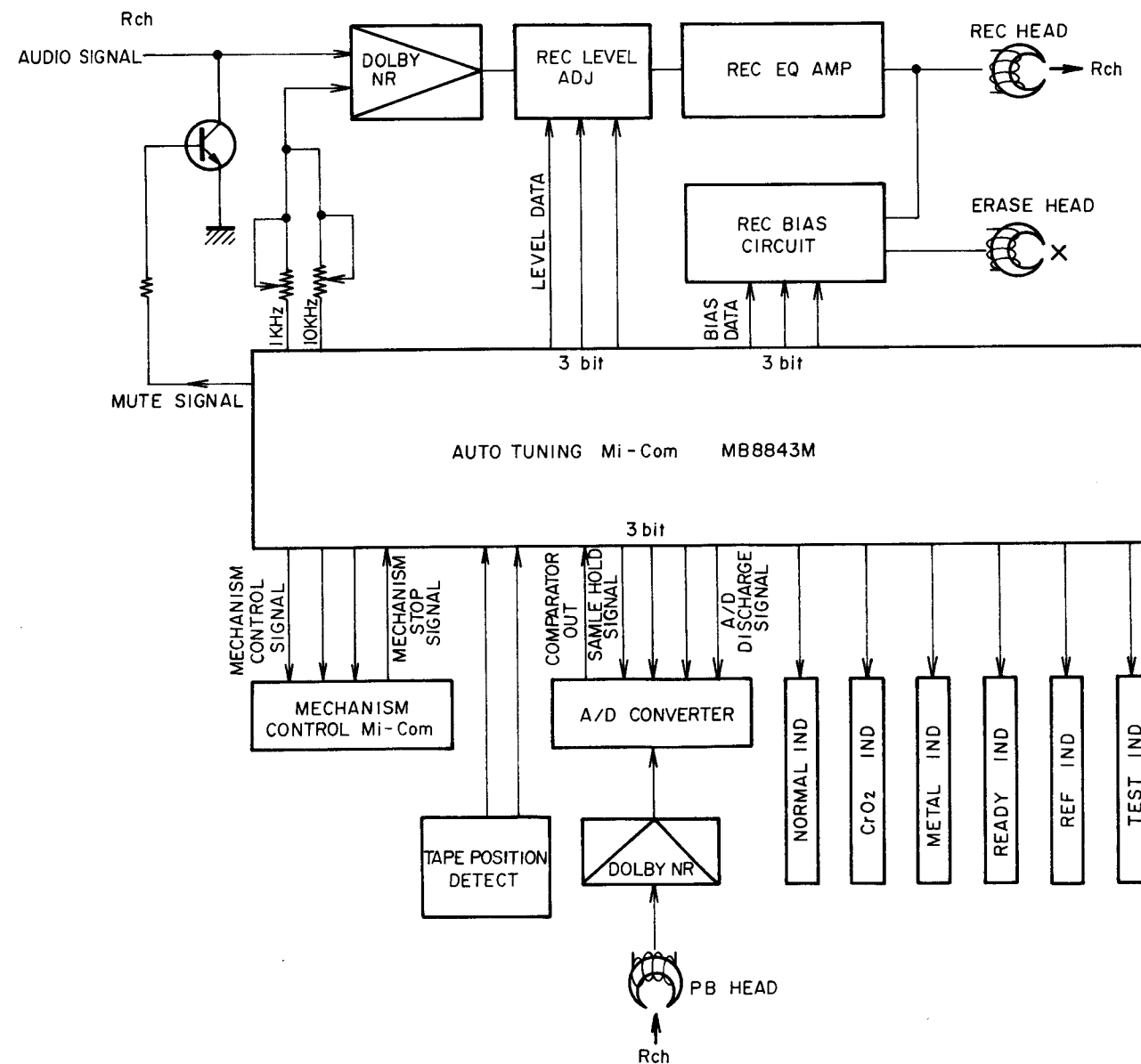

Fig. 4

3. GX-F51 AUTO TUNING FUNCTION DIAGRAM

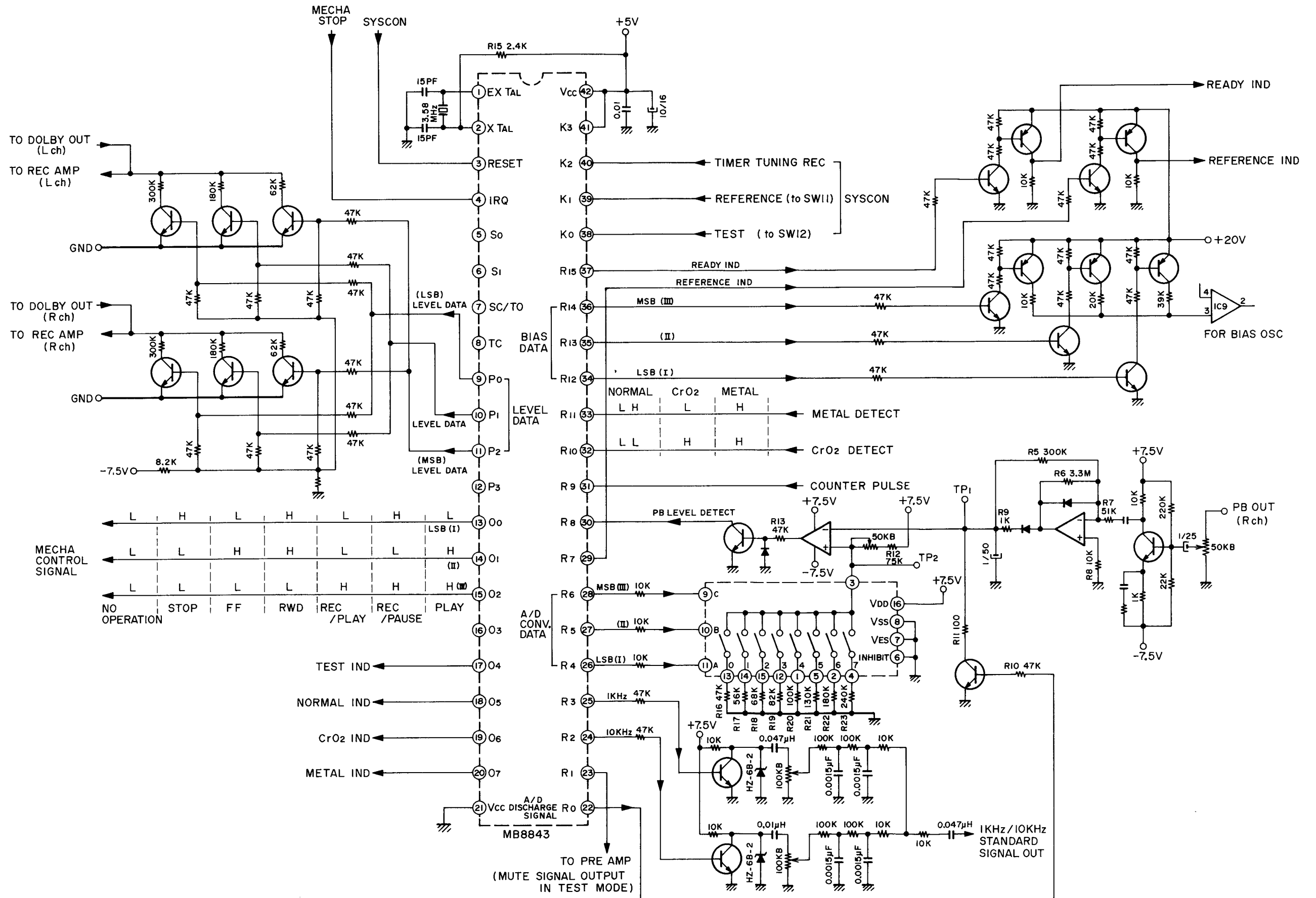

Fig. 5

4. GX-F51 PRE AMP BLOCK DIAGRAM

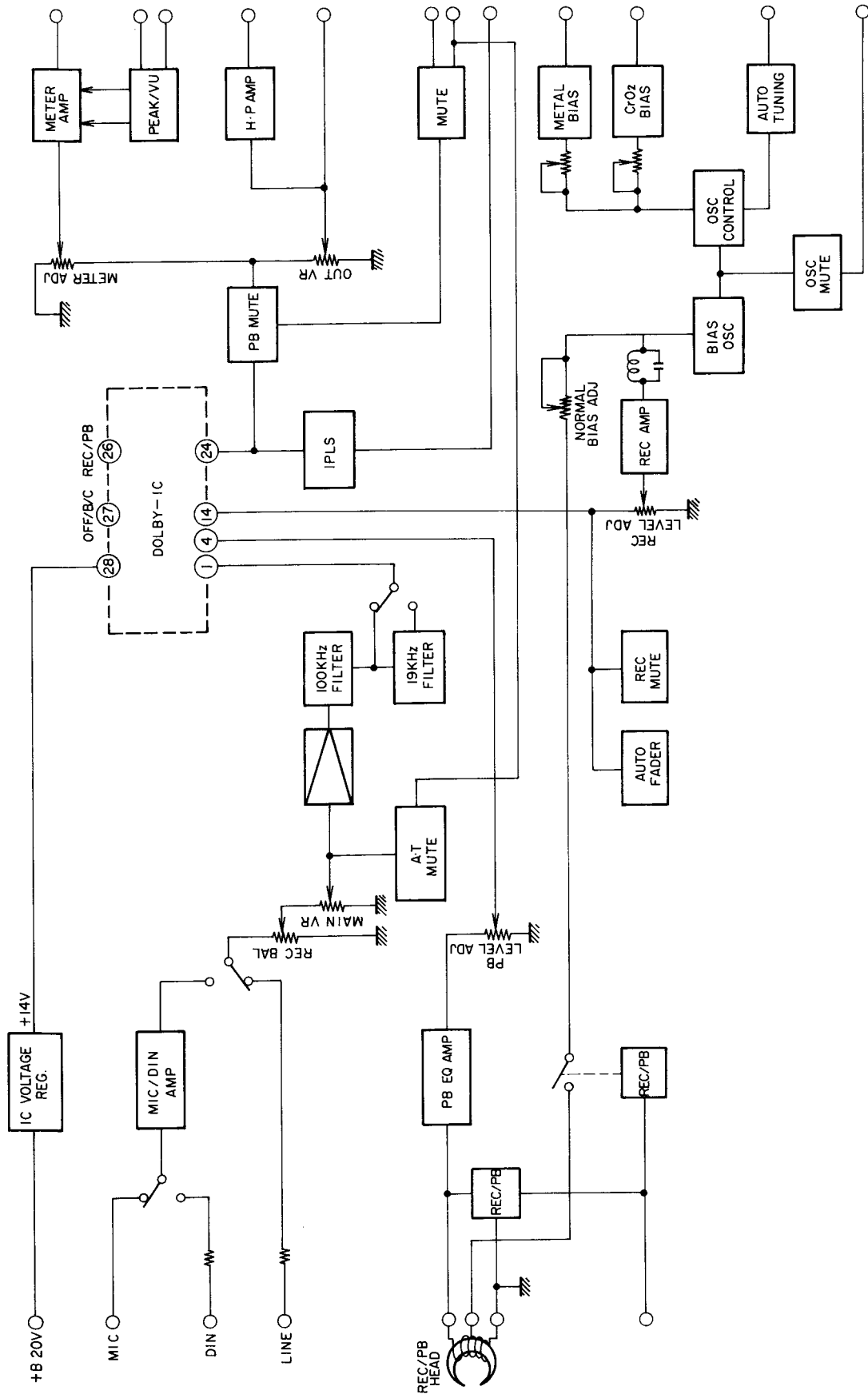

Fig 6 Features; Circuit of REC-PB is switched in DOLBY IC. Switching of DOLBY-OFF, DOLBY-B, DOLBY-C are made in DOLBY IC.

IV. AUTO FADER CIRCUIT

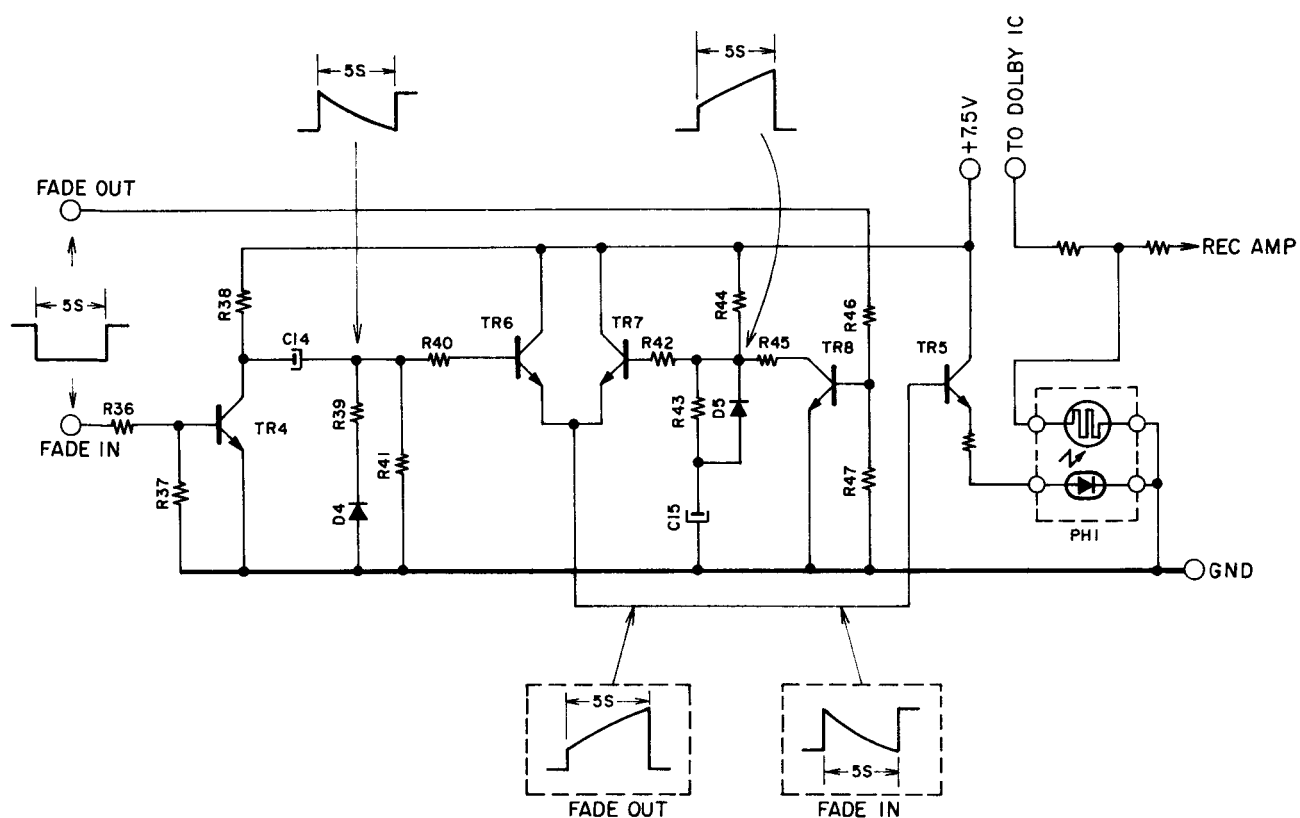

Fig. 7

Functions (Symbol numbers of GX-F71 are used to explain, but the function of GX-F51 is same as the function of GX-F71).

1. **FADE IN;** When AUTO FADER is depressed in REC PAUSE mode, the fade-in terminal becomes "L" level for about 5 seconds. Then, TR4 is turned off and TR4's collector becomes "H" level and, therefore, an excessive current flows through C14. This excessive current is discharged at R41, 68K. By using this discharge curve, the current flowing through photo sensor (MCD7213P) is reduced gradually.

○ Photo sensor; The internal resistance is changed by the current which flows through the diode in the sensor. The more current flows, the less resistance becomes and the less current flows, the more resistance becomes.

2. **FADE OUT;** When AUTO FADER is depressed in REC mode, the FADE OUT terminal becomes "L" level for about 5 sec.

Then, since TR8 is turned off, C15 is electrically charged through R44 and R43. By using the charging curve, the current flowing through the photo sensor is increased gradually.

V. CAM MOTOR DRIVE CIRCUIT

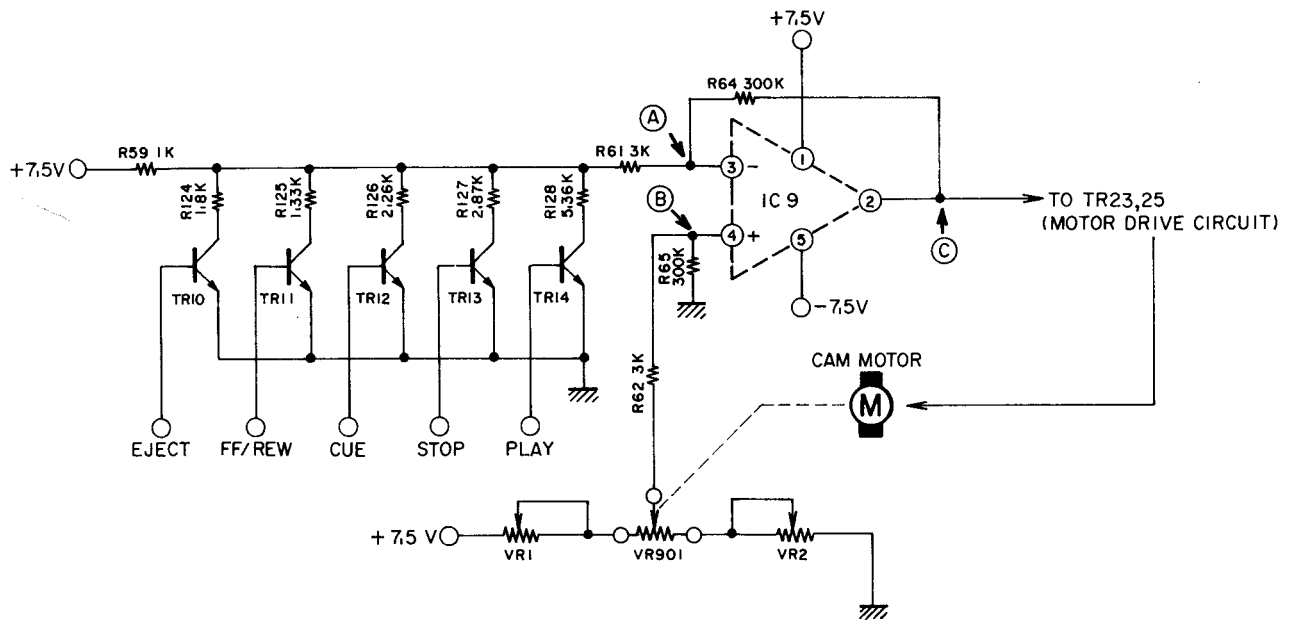

Fig. 8 Motor Revolution Indication Circuit

The cam motor is used for the operation of mechanism. It determines the position of the head base in each mode; power eject mode and auto loading mode. (Plunger used to be employed for this operation.)

Circuit functions (Symbol numbers of GX-F71 are used for the explanation, but the functions are same as those of GX-F31/F51).

TR10 ~ TR14 are turned on by the signal from IC8 (MICOM) in each mode.

By the difference in the value of resistances of R124 ~ R128, the voltage at point A is determined in each mode and this voltage is used as the standard voltage of OP Amp (IC9).

At IC9, the voltage at point A is compared with that at point B and when $A > B$, point C becomes "L" (-7V) and when $A < B$, point C becomes "H" (+7V) and when $A = B$, point C becomes "0" (Approx. -3V ~ +3V).

Supposing that point C is "H" (+7V).

TR23 "ON" → TR24 "OFF" → TR30 "OFF" → TR19 "OFF" and the collector of TR19 becomes "H"

while at the same time, TR25 "ON" → TR29 "OFF" → TR20 "ON" and the collector of TR20 becomes "L". Therefore, the motor turns.

Since the cam motor and VR901 are interlock each other, the voltage at point B is changed as the motor turns. The motor stops when the voltage at point A becomes equal to the voltage at point B, that is, when the voltage at point C becomes "0".

While point C is "L" (-7V), the on/off of TR is reverse direction.

TR31 and 32 are provided for shorting both ends of motor and applying brakes when the voltage at point C is "0".

When point C is "H" or "L", "H" is applied to IC7 ⑨ and IC7 ⑩ becomes "L" and then TR33 "OFF" → TR31 and 32 "OFF" and, therefore, both ends of motor are not shorted. When point C is "0", IC7 ⑨ is "L" and IC7 ⑩ "H" → TR33 "ON" → TR31 and 32 "ON" and, consequently, both ends of motor are shorted and brake is applied.

VI. REEL MOTOR DRIVE CIRCUIT

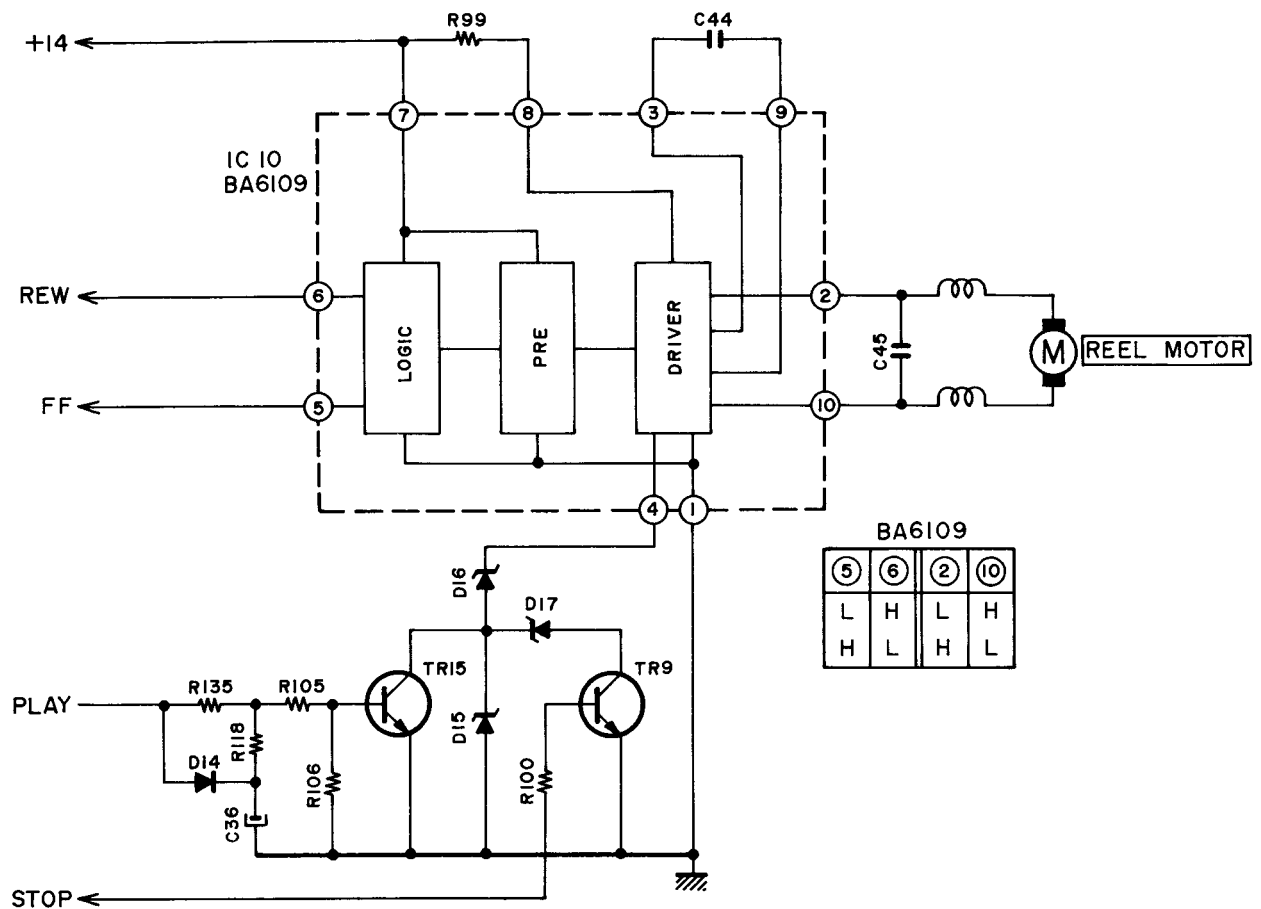

Fig. 9 GX-F71 Reel Motor Drive Circuit

Functions

IC10 ⑥ is "H" in REW mode and then ⑩: H and ②: L and the motor turns in the reverse direction.

IC10 ⑤ is "H" in FF mode and the ②: "H" and ⑩: "L" and the motor turns in the normal direction.

In the PLAY mode, IC10 ⑤ becomes "H" and the motor turns, but voltage ④ changes to voltage (5V) D16 as TR15 is turned on and voltage ② is reduced to 5V, thus determining the take up tension.

With GX-F51, F31, FF input is ⑥ and REW input is ⑤.

Only the outputs of ② and ⑩ are reversed and the function remains unchanged.



SECTION 2

SERVICE MANUAL

MODEL GX-F31

TABLE OF CONTENTS

I. SPECIFICATIONS	2- 2
II. CONTROLS	2- 3
III. PRINCIPAL PARTS LOCATION	2- 4
IV. VOLTAGE AND CYCLE CONVERSION	2- 5
V. MECHANICAL ADJUSTMENT	2- 6
VI. HEAD ADJUSTMENT	2- 9
VII. AMPLIFIER ADJUSTMENT	2-11
VIII. DC RESISTANCE OF HEADS	2-13
IX. CLASSIFICATION OF VARIOUS P.C BOARDS	2-13
1. P.C BOARD TITLES AND IDENTIFICATION NUMBERS	2-13
2. COMPOSITION OF VARIOUS P.C BOARDS	2-14

For basic adjustments, measuring methods, and operating principles, refer to GENERAL TECHNICAL MANUAL.

I. SPECIFICATIONS

TRACK SYSTEM	4 Track 2 Channel Stereo System
TAPE	Philips Type Cassette
TAPE SPEED	4.76 cm/s \pm 1.0% (1-7/8 ips. \pm 1.0%)
HEADS	Twin Field Super GX head for recording/playback \times 1 Erase head \times 1
MOTORS	FG servo D.C. motor for direct capstan drive \times 1 D.C. motor for reel drive \times 1
WOW & FLUTTER	0.10% WTD (DIN) 0.035% WRMS
TAPE WINDING TIME	90 sec. using a C-60 cassette tape
FREQUENCY RESPONSE	Normal: 20 to 17,000 Hz \pm 3 dB CrO ₂ : 20 to 18,000 Hz \pm 3 dB Metal: 20 to 19,000 Hz \pm 3 dB
FREQUENCY RANGE	Normal: 15 to 18,000 Hz CoO ₂ : 15 to 20,000 Hz Metal: 15 to 21,000 Hz
SIGNAL TO NOISE RATIO	Metal: 60 dB (measured via tape with peak recording level) Dolby B-type NR switch ON: Improves up to 5 dB at 1 kHz, 10 dB above 5 kHz Dolby C-type NR switch ON: Improves up to 15 dB at 500 Hz, 20 dB at 1 kHz to 10 kHz
HARMONIC DISTORTION	1 kHz, 3rd harmonic distortion Metal: 0.8%
INPUT	MIC: 0.25 mV (600 ohms) Line: 70 mV (47 kohms)
OUTPUT	Line: 410 mV (less than 2 kohms) Phone: 1.3 mW (8 ohms)
DIN	Input: 2.0 mV (10 kohms) Output: 410 mV
POWER REQUIREMENTS	100V, 50/60 Hz for Japan 120V, 60 Hz for USA and Canada 220V, 50 Hz for Europe except UK 240V, 50 Hz for UK and Australia 110V/120V/220V/240V, 50/60 Hz switchable for other countries.
POWER CONSUMPTION	U, C, A Models 22W J Model 20W
DIMENSIONS	440(W) \times 100(H) \times 345(D) mm (17.3 \times 3.9 \times 13.6")
WEIGHT	5.8 kg (12.8 lbs)

* For improvement purposes, specifications and design are subject to change without notice.

* "Dolby" and the Double D symbol are trademarks of Dolby Laboratories.

(Manufactured under license from Dolby Laboratories).

II. CONTROLS

GX-F31

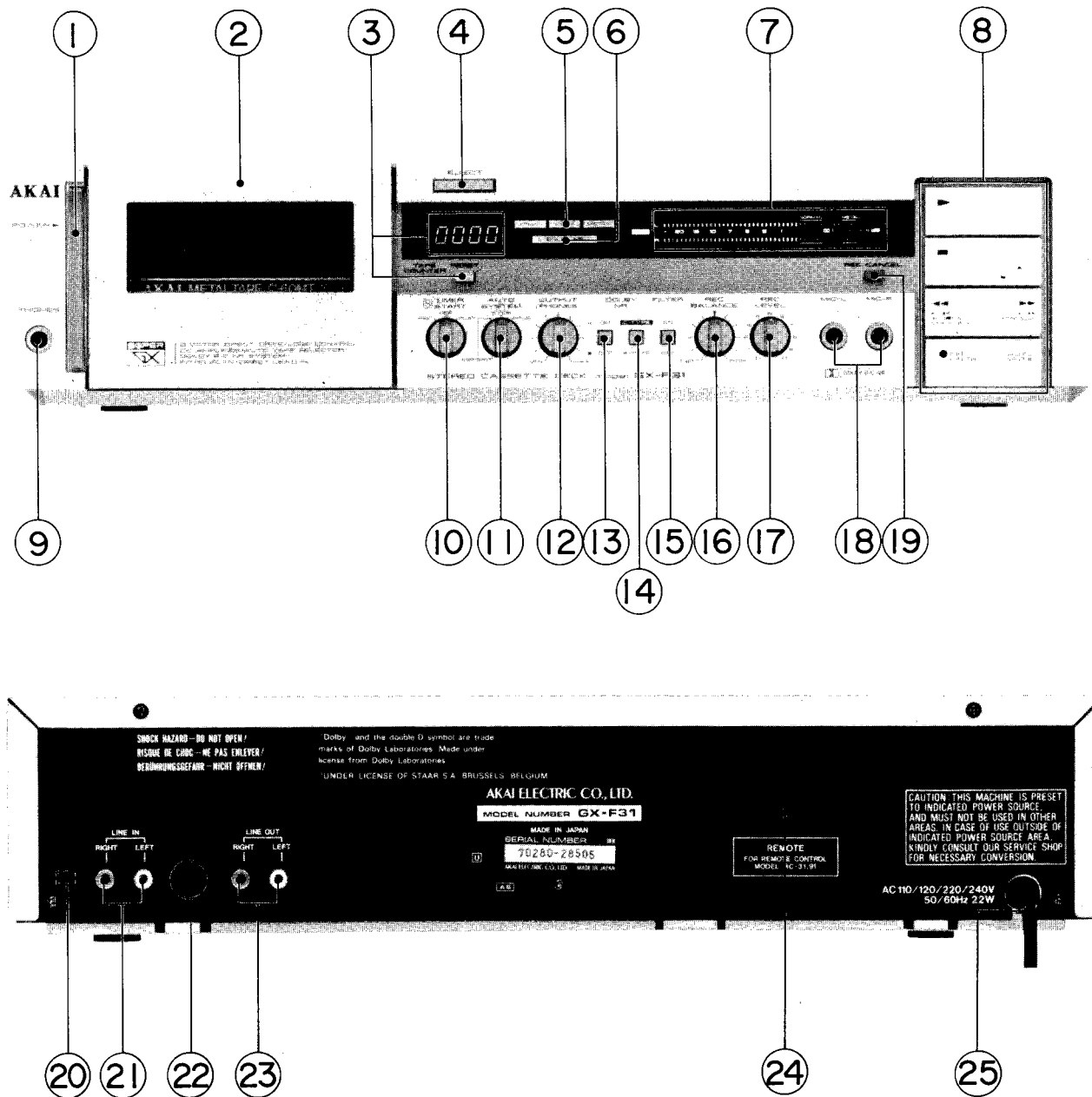

Fig. 1 Controls

- | | |
|--|--|
| 1. POWER SWITCH | 12. OUTPUT/HEADPHONE (PHONES) CONTROL |
| 2. CASSETTE RECEPTACLE | 13. DOLBY NR SWITCH |
| 3. FLD TAPE COUNTER and RESET BUTTON | 14. DOLBY NR SELECTOR |
| 4. EJECT BUTTON | 15. MPX FILTER SWITCH |
| 5. TAPE POSITION INDICATOR | 16. RECORDING (REC) BALANCE CONTROL
(LEFT and RIGHT) |
| 6. DOLBY NR INDICATOR | 17. RECORDING (REC) LEVEL CONTROL |
| 7. FLD BAR METER with MAXIMUM INPUT LEVEL INDICATORS | 18. MICROPHONE JACKS (MIC-L: left, MIC-R: right) |
| 8. OPERATING BUTTONS
PLAY (▶) BUTTON with INDICATOR
STOP (■) BUTTON
REWIND (◀◀) BUTTON
FAST FORWARD (▶▶) BUTTON
RECORDING (REC)/PAUSE BUTTON with INDICATOR
AUTO MUTE BUTTON | 19. RECORDING (REC) CANCEL BUTTON |
| 9. HEADPHONE (PHONES) JACK | 20. LINE/DIN SELECTOR
(Some models do not have this facility.) |
| 10. TIMER START SELECTOR | 21. LINE IN JACKS |
| 11. AUTO SYSTEM SELECTOR | 22. DIN JACK
(Some models are not equipped with this facility.) |
| | 23. LINE OUT JACKS |
| | 24. REMOTE JACK |
| | 25. POWER CORD |

III. PRINCIPAL PARTS LOCATION

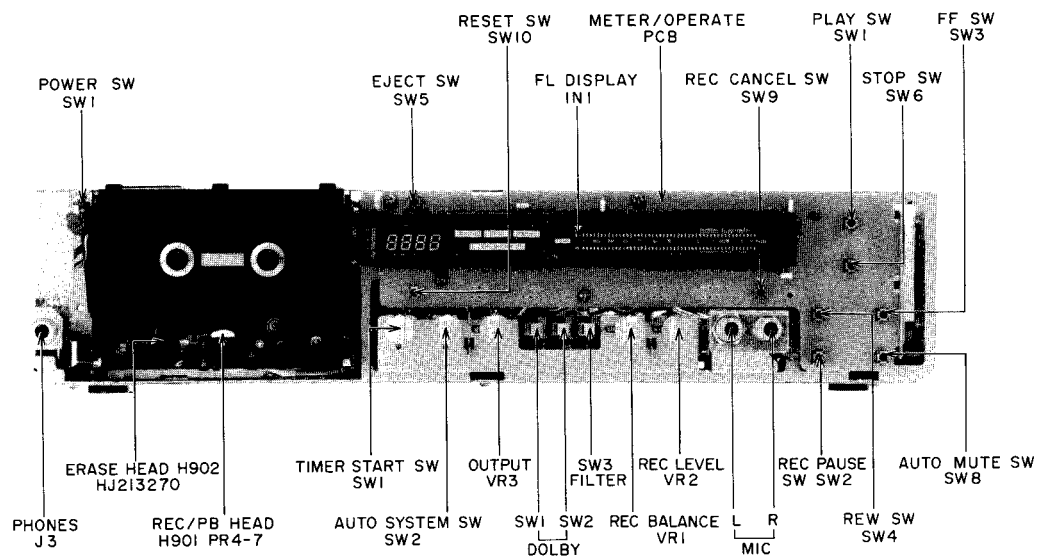

Fig. 2 Front View

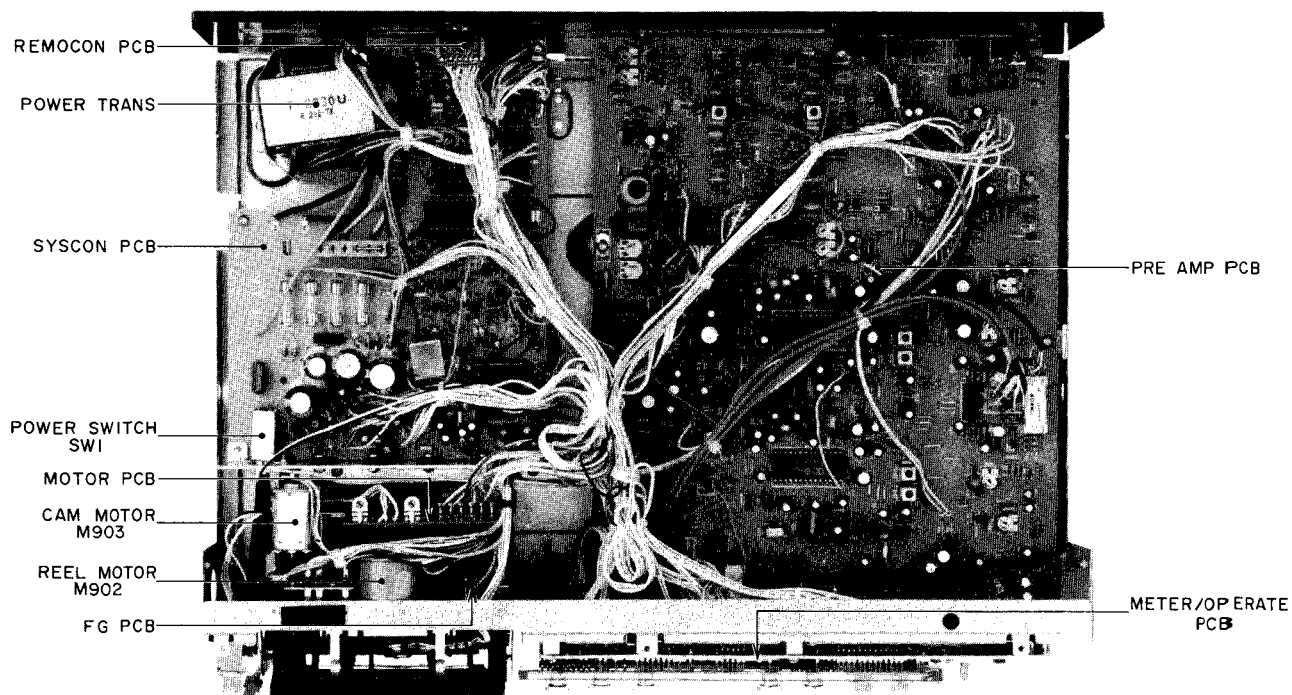

Fig. 3 Top View

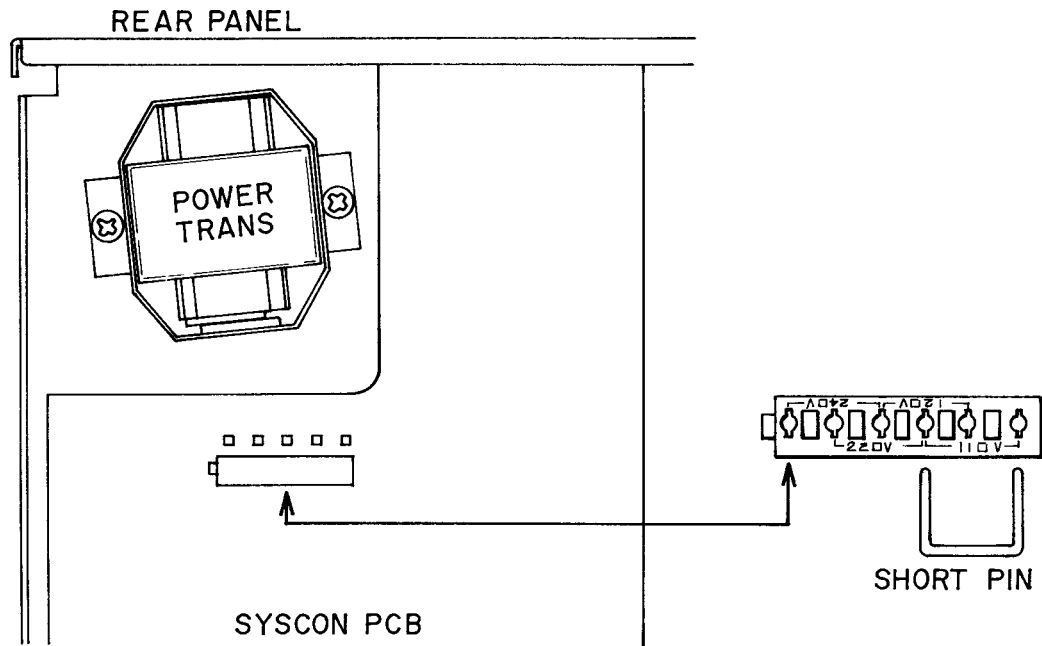

Fig. 4 Voltage Conversion (U Model only)

1. VOLTAGE CONVERSION

Models for Canada, Europe, USA, UK and Australia are not equipped with this facility.

Each machine is preset at the factory according to destination, but some machines can be set to 110V, 120V, 220V or 240V as required.

If voltage change is necessary, this can be accomplished as follows:

- 1) Disconnect power cord.
- 2) Loosen holding screws and remove upper cover.
- 3) Remove short pin plug from present holes and replace in correct holes. Follow the markings explicitly.

2. CYCLE CONVERSION

With DC motor, cycle conversion is not necessary.

V. MECHANICAL ADJUSTMENT

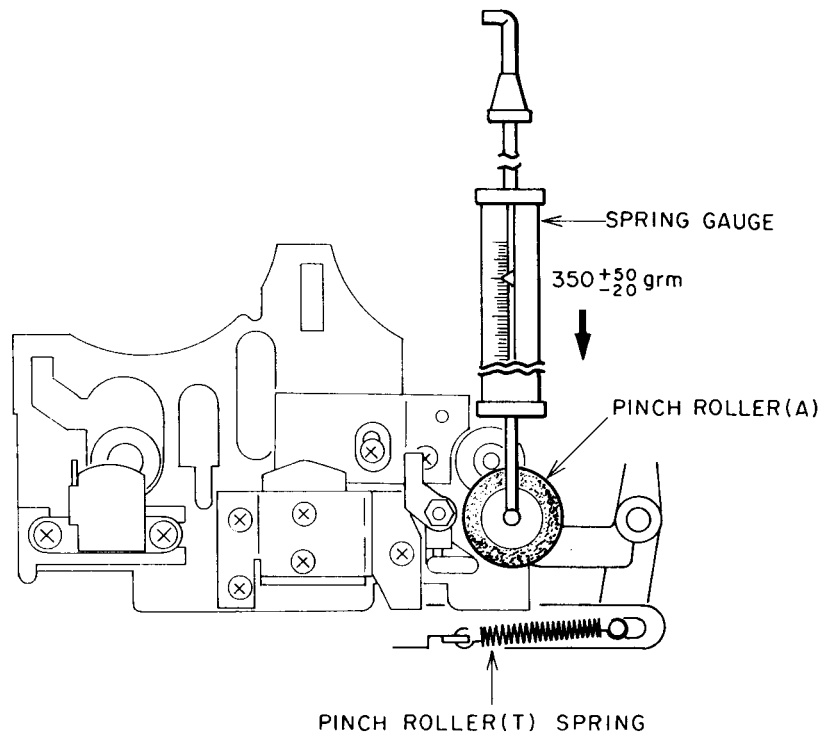

Fig. 5

1. PINCH ROLLER PRESSURE MEASUREMENT (Refer to Fig. 5)

Put in PLAY mode. Push pinch roller arm down with the spring gauge push the pinch roller 1 ~ 2 mm from the capstan and release slowly. Read the spring gauge at the moment the pinch roller touches the capstan and begins to rotate.

Specified pressure: $350 \pm 50 \text{ gm}$. If there is no measurement obtained, replace the pinch roller spring.

2. TAPE SPEED ADJUSTMENT

Play Back a 1,000 Hz (TF-102CS) Pre-Recorded test tape, and Adjust tape Speed Adjustment Volume (VR1 50K) to obtain a tape speed of 1,000 Hz $\pm 1.0\%$.

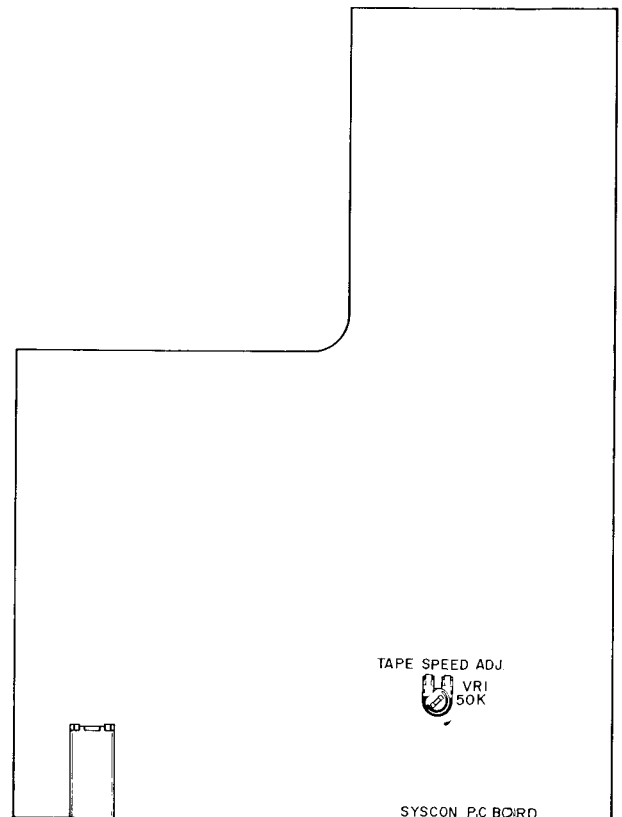

Fig. 6 Syscon P.C Board Adjustment Point

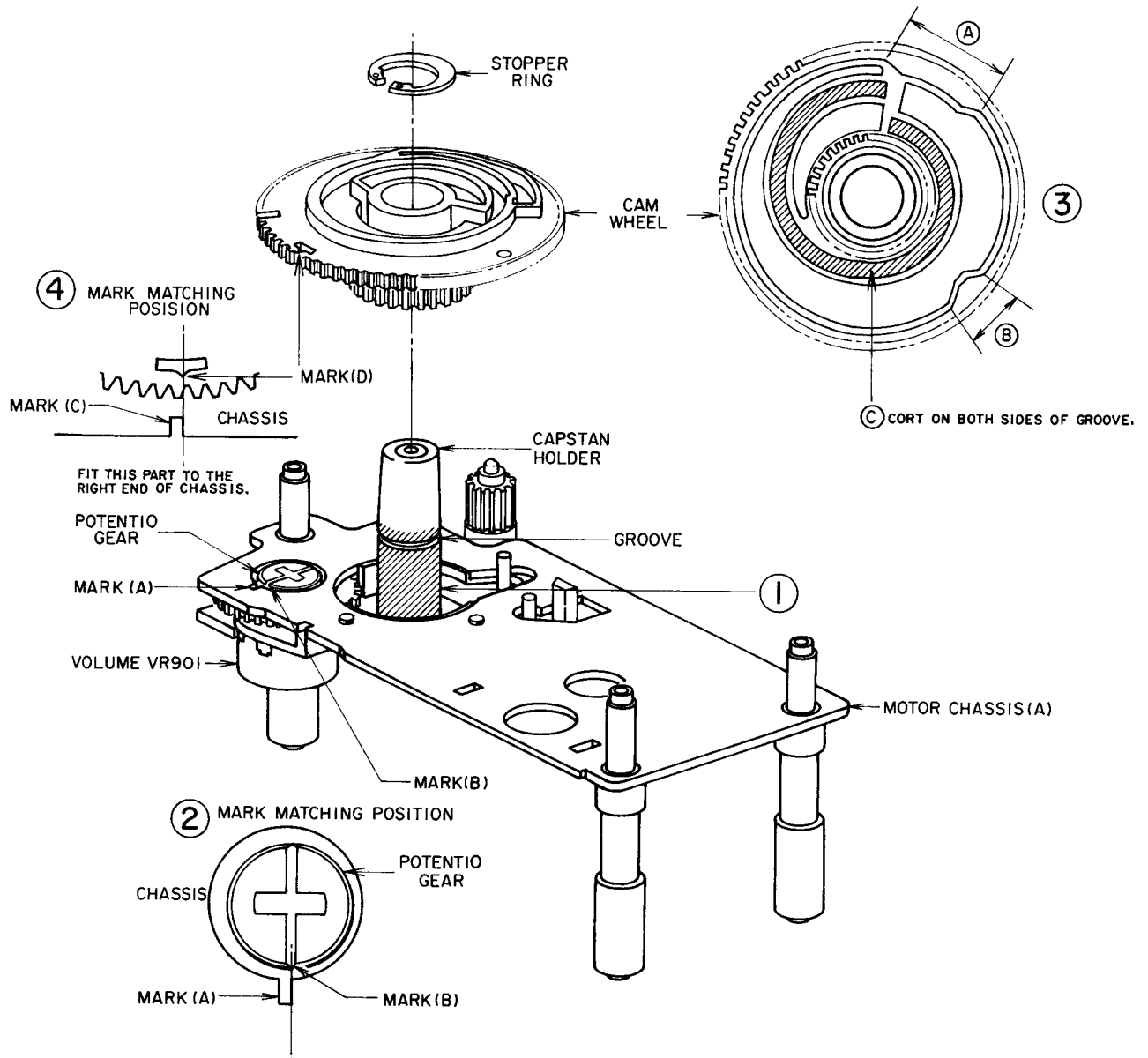

Fig. 7

3. HOW TO INSTALL VOLUME (VR901) AND CAM WHEEL

- 1) Apply Molybdenum coat on the capstan holder
Apply Molybdenum coat on the area of 360° from the bottom to the upside 2 mm of groove as shown in the figure. (Fig. 7-①)
- 2) Fitting position volume (potentio gear)
Fit the right end of Mark (A) to the center of Mark (B) as shown in the figure. (Fig. 7-②)
- 3) Apply Molybdenum coat on (A), (B) and (C) shown in Fig. 7-③.
- 4) Set the cam wheel on the capstan wheel
(Ensure that the cam wheel and potentiometer gear are

meshed properly). When the cam wheel is set properly, fit the center of Mark (D) to the right end of Mark (C). (Fig. 7-④)

- 5) Fit the stopper ring in the groove of the capstan holder.

CAUTIONS:

1. Make sure that the teeth on the periphery of cam wheel and the cam are absolutely free from any scratch, flaw, cut, etc.
2. Make sure that Molybdenum coat is applied on the specified area only.

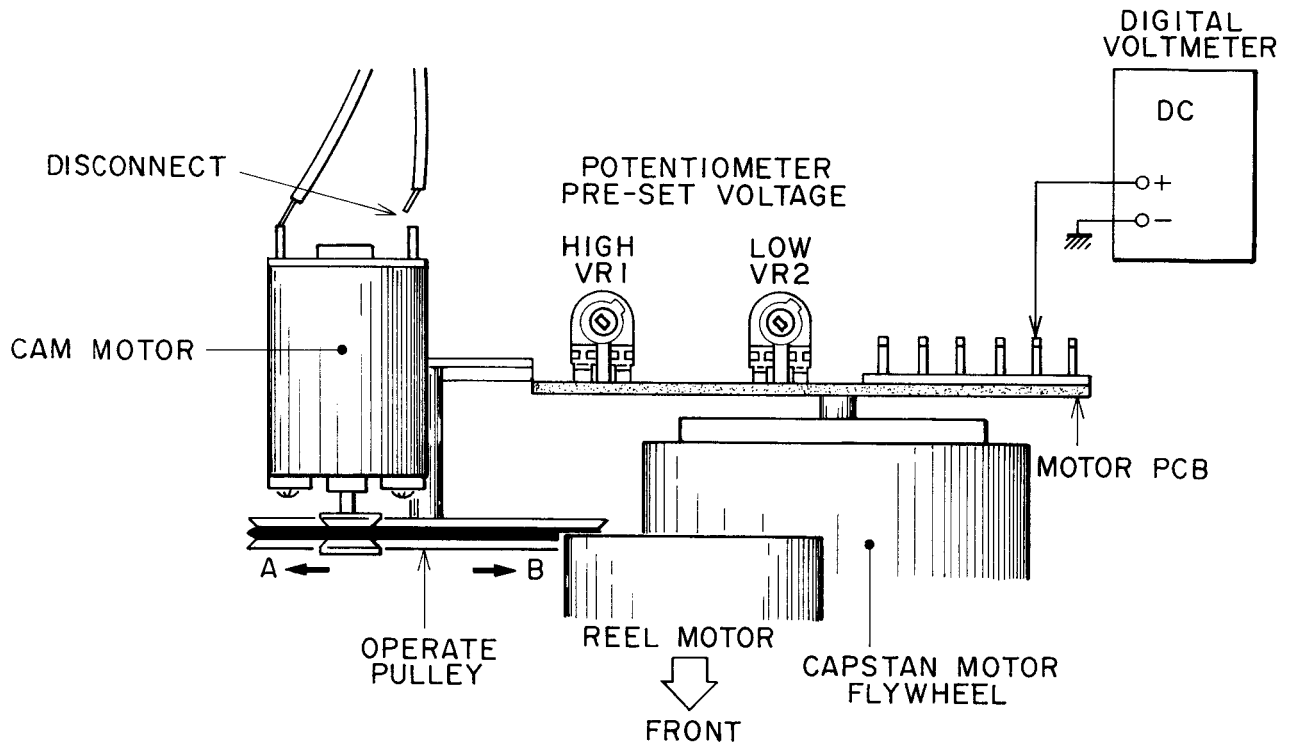

Fig. 8-1

4. POTENTIOMETER PRESET VOLTAGE ADJUSTMENT

1) LOW VOLTAGE ADJUSTMENT

- a. With power OFF, remove the connecting cord of the cam motor and turn the operate pulley fully with your fingers in A direction.
- b. Connect the digital voltmeter as shown in Fig. 8-1.
- c. With power ON, adjust VR2 so that the voltage reading will be 0.78V (DC).

2) HIGH VOLTAGE ADJUSTMENT

- a. With power OFF, turn the operate pulley fully with your fingers in B direction.
- b. With power ON, adjust VR1 so that the voltage reading will be 6.73V (DC).

3) Repeat Items 1) and 2).

- 4) a. With Power OFF, connect the connecting cord of the motor.
- b. Remove the digital voltmeter.

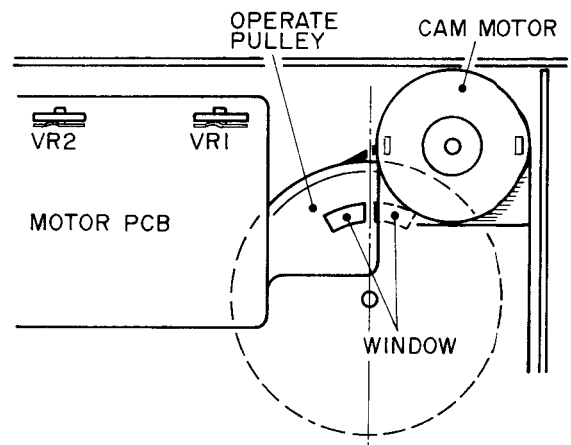

Fig. 8-2 Position of Operate Pulley in STOP Mode

- 5) a. Set power to ON.
- b. Adjust VR1 slightly so that a center line between windows of the operate pulley will face directly above during STOP Mode. (Fig. 8-2)
- c. Remove the cassette lid and set the AUTO SYSTEM switch to IPLS Mode.
- d. Confirm that the head and pinch roller do not move up and down when the FF and REW switches are alternately depressed.
- e. Turn the reel with fingers in STOP Mode to check that the brake works sufficiently. When the brake acts normally, the take-up reel does not turn clockwise while the supply reel does not rotate counterclockwise.

VI. HEAD ADJUSTMENT

GX-F31

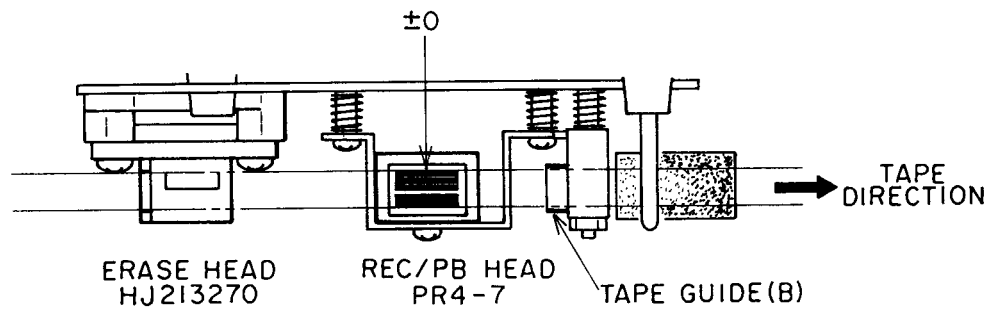
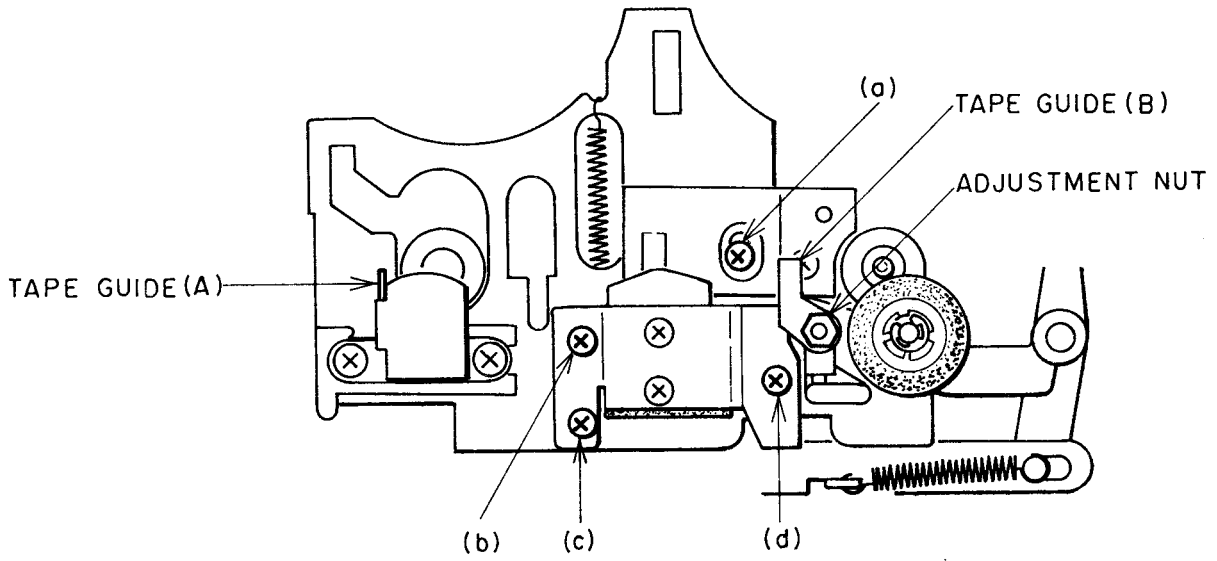

Fig. 9

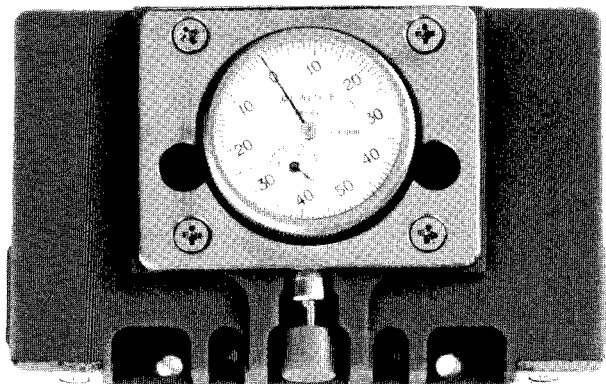

Fig. 10 Cassette Head Projection Gauge (TF-111CJ)



Fig. 11 Mirror Cassette Tape (TF-109CM)

1. REC/PB HEAD PROJECTION

ADJUSTMENT

Set the cassette head projection gauge (TF-111CJ) and set to PLAY mode. Loosen the screw (a) and adjust so that the gauge indication at that time will be 3.2 ± 0.05 mm. After adjustment, apply paintlock on the screw (a).

2. TAPE GUIDE HEIGHT ADJUSTMENT

- 1) Set the mirror cassette tape (TF-109CM) and set to PLAY mode.
- 2) Using the tape guide (A) as reference height, adjust the tape guide (B) so that the tape runs smoothly and is not hitched by the tape guide. For the adjustment, use the adjustment nut. After adjustment, apply paintlock on the adjustment nut.

3. REC/PB HEAD HEIGHT ADJUSTMENT

- 1) Set the mirror cassette tape and set to PLAY mode.
- 2) Adjust screws (b), (c) and (d) so that the upper edge of the REC/PB head L-ch core is in alignment with the upper side of the tape.
- 3) Playback the head height adjustment tape (4Tr 1,000 Hz) (TF-103CF) and fine-adjust the screws (b), (c) and (d) so that the largest output is obtained for both channels.

4. REC/PB HEAD AZIMUTH

ALIGNMENT ADJUSTMENT

- 1) Playback a 10 kHz head azimuth alignment tape (TF-106CH) and adjust the screw (d) until the output level of both channels is maximum.
- 2) After adjustment, better to check again head height and azimuth alignment.
- 3) After adjustment, paintlock the screws (b), (c) and (d).

NOTES:

1. Be sure to clean the heads prior to head adjustment.
2. Be careful not to use a magnetized driver or other magnetized tools in the vicinity of the heads.
3. Be sure to demagnetize the heads with a Head Demagnetized before and after head adjustment.

VII. AMPLIFIER ADJUSTMENT

* ↻ direction increases the level (bias will be shallower)

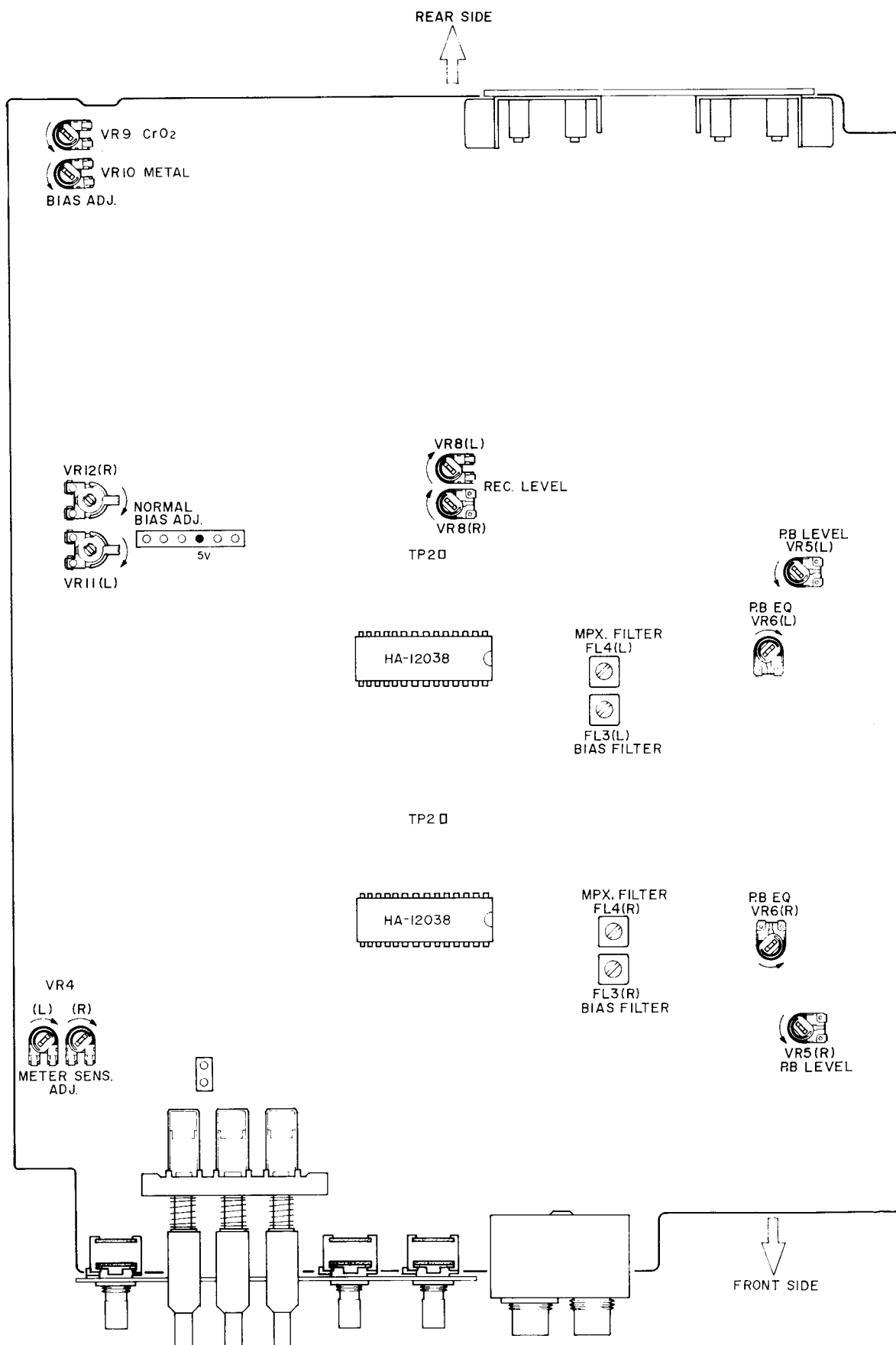

Fig. 12 Pre-Amp P.C Board Adjustment Point

Step	Adjustment Item	Test Tape Supply Signal	Mode	Adjustment Parts	Result	Remarks
1	PB Level	333 Hz (TF-101CL)	PB	VR5	-5.5 ± 0.2 dBm (410 mV)	
2	PB EQ	10 kHz (TF-106CH)	PB	VR6	-22.5 ± 1.5 dBm	
3	Normal Position Frequency Response	Normal Blank Tape 1 kHz, 10 kHz -22.5 dBm	REC/PB	VR11	1 kHz to 10 kHz flat response	
4	CrO ₂ Position Frequency Response	CrO ₂ Blank Tape 1 kHz, 10 kHz -25.5 dBm	REC/PB	VR9	1 kHz to 10 kHz flat response	
5	Metal Position Frequency Response	Metal Blank Tape 1 kHz, 10 kHz -25.5 dBm	REC/PB	VR10	1 kHz to 10 kHz flat response	
6	REC Level	Normal Blank Tape 1 kHz, -5.5 dBm	REC/PB	VR8	-5.5 ± 0.3 dBm (410 mV)	
7	MPX Filter	19 kHz from oscillator	REC	FL4	Minimum Output	MPX Filter ON
8	Bias Filter	No Signal Input	REC	FL3	Minimum Output	Set REC Volume to maximum
9	Meter Sensitivity	1 kHz, -5.5 dBm from oscillator	REC	VR4	0 dB Indication	+1VU puts out the light in Line out -5.2 dBm

NOTES: 1. Except for Step 7 set MPX Filter Switch to OFF Position.

2. Use the following cassette measuring tapes:

Normal Tape : Maxell UD C-60

CrO₂ Tape : TDK SA C-60

Metal Tape : TDK MA-C C-60

For your reference:

Confirmation of Dolby level

1) Set to REC/PAUSE.

2) Input a signal of 400 Hz and adjust the input level so that the level of pin ② of Dolby I.C (HA-12038) will be 580 mV when Dolby NR is OFF.

3) Check that the level of TP-2 is 580 mV.

VIII. DC RESISTANCE OF HEADS

GX-F31

Description	Name	DC Resistance
REC/PB Head	PR4-7	650 ohms \pm 10%
Erase Head	HJ213270	3.5 ohms

IX. CLASSIFICATION OF VARIOUS P.C BOARDS

1. P.C BOARD TITLES AND IDENTIFICATION NUMBERS

P.C Board Title	P.C Board Number
Pre Amp P.C Board	T2029A501A
Phone Jack P.C Board	T2029A501B
Syscon P.C Board	T2030B 502A
Switch P.C Board	T2030B502B
Remocon P.C Board	T2030B502C
Meter/Operate P.C Board	T2030B5030
Motor P.C Board	M3103C726A
Potention P.C Board	M3103C726B
FG P.C Board	M3103C7130
Filter P.C Board	T2029D5040
Detector P.C Board	T2029D5030
Micro SW P.C Board	T2029D5020

2. COMPOSITION OF VARIOUS P.C BOARDS

1) PRE AMP P.C BOARD T2029A501A (2ED) and PHONE JACK P.C BOARD T2029A501B

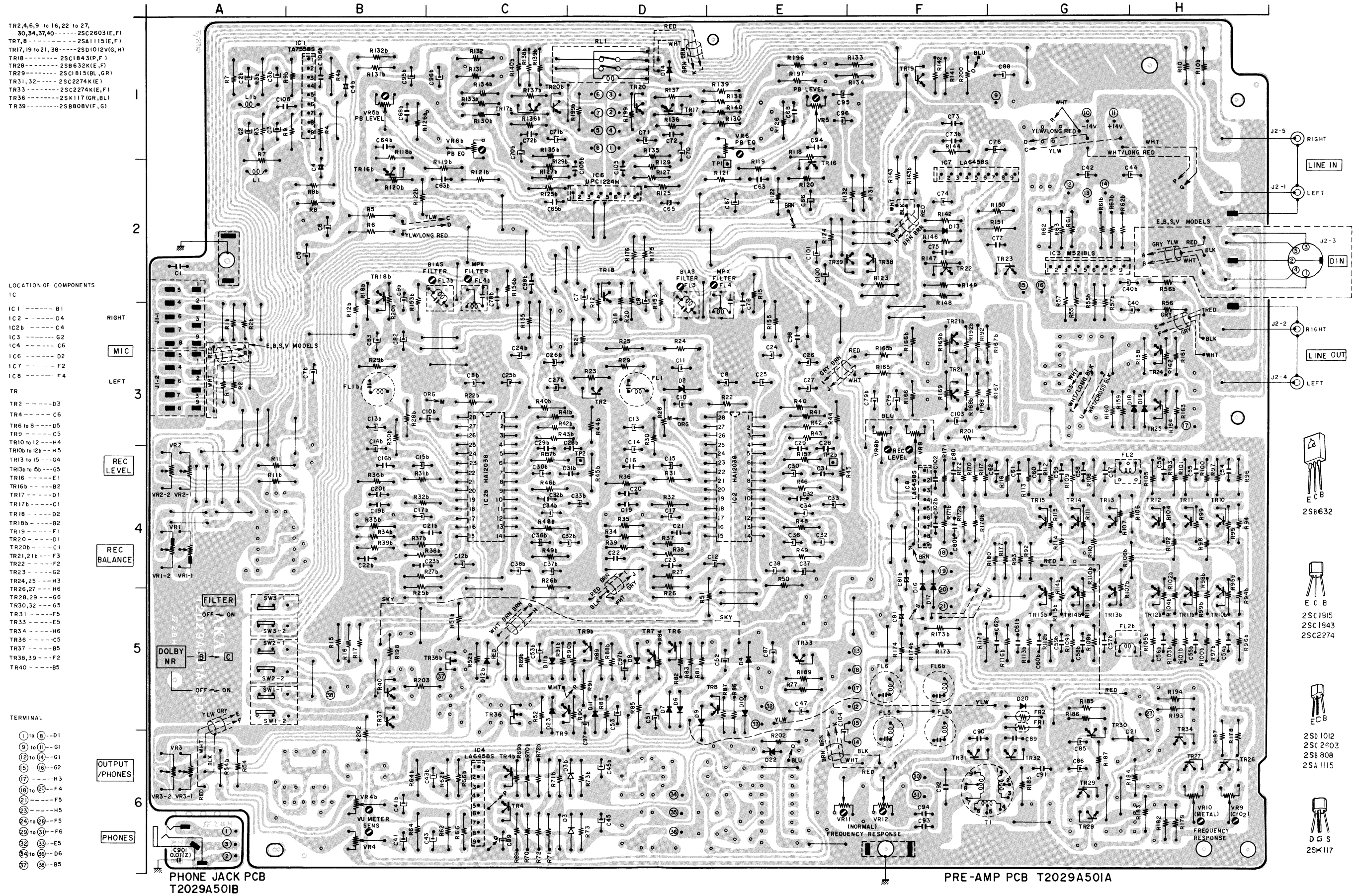

2) SYSCON P C BOARD T2030B502A (3ED), SWITCH P.C BOARD T2030B502B and REMOCON P.C BOARD T2030B502C (2ED)

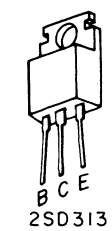
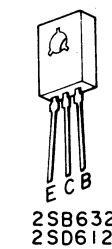
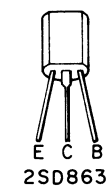
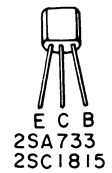
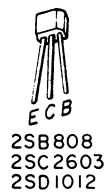

- TR1----2SB632K(E,F)
- TR2,3---2SD612K(E,F)
- TR4,8---2SC1815(BL,GR)
- TR5----2SD863(E,F)
- TR6----2SD612K(E,F)
- TR7----2SD313HP(E,F)
- TR9 to 17 24 to 27,29
-----2SC2603(E,F)
- TR18 to 21---2SB808V(G,H)
- TR22,23---2SD1012V(G,H)
- TR30---2SA733A(P,Q)

- IC 1----LM6402H-063
- IC 2,3---LB1290
- IC 4,5---LC7800
- IC 6----LC4049
- IC 7----LA6458S
- IC 8----BA6109
- IC 9----μPC1043
- IC 10---M5230L

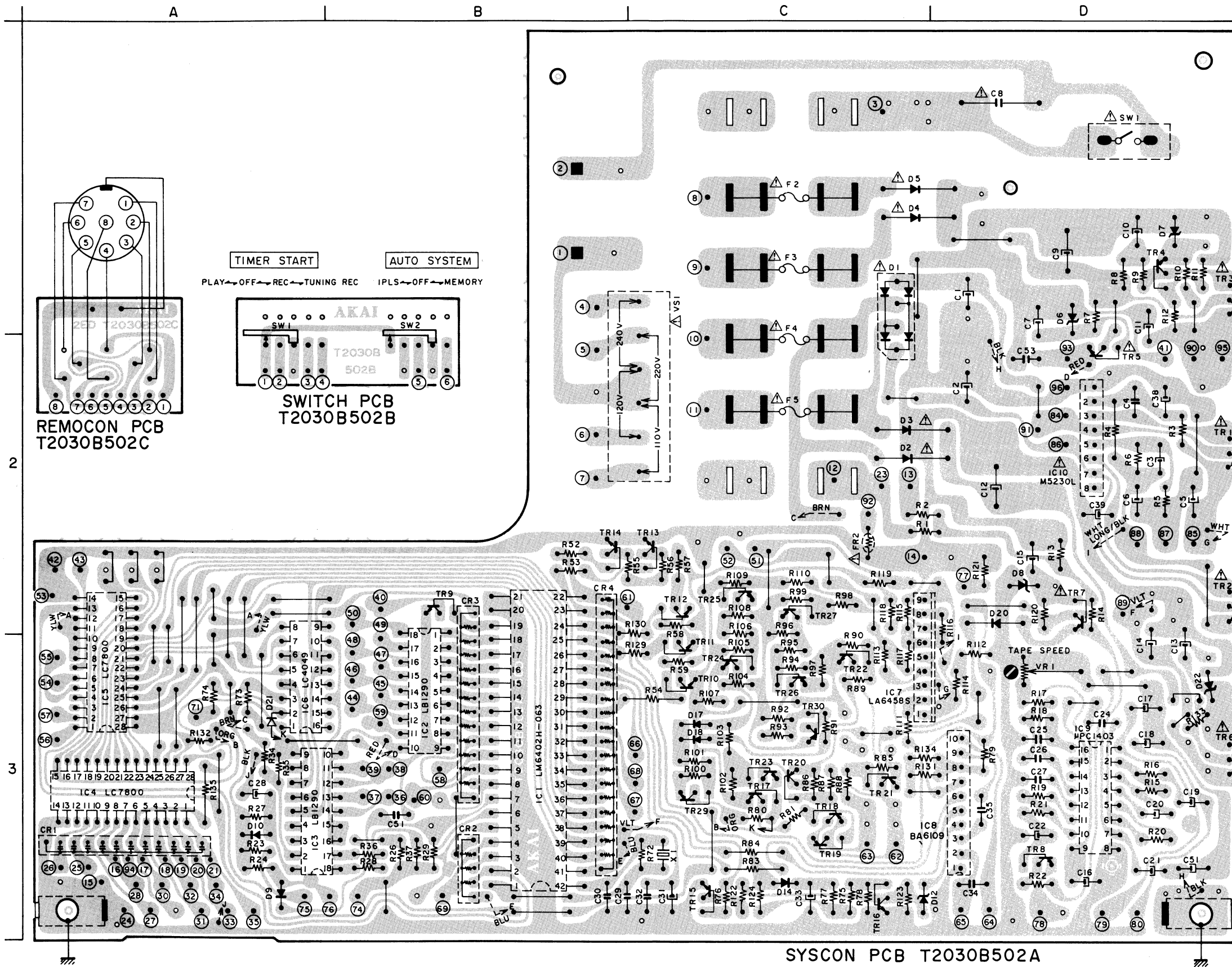

U MODEL
POWER

LOCATION OF COMPONENTS

- TR
- TR1, 2 ----- D2
 - TR3, 4 ----- D1
 - TR5 ----- D2
 - TR6 ----- D3
 - TR7 ----- D2
 - TR8 ----- D3
 - TR9 ----- B2
 - TR10, 11 ----- C3
 - TR12, 13 ----- C2
 - TR14 ----- B2
 - TR15 to 24 ----- C3
 - TR25 ----- C2
 - TR26 ----- C3
 - TR27 ----- C2
 - TR29, 30 ----- C3

- IC
- IC1, 2 ----- B3
 - IC3 to 6 ----- A3
 - IC7 ----- C3
 - IC8, 9 ----- D3
 - IC10 ----- D2

TERMINAL

- ① ② ----- B1
- ③ ----- C1
- ④ ----- B1
- ⑤ to ⑦ ----- B2
- ⑧, ⑨ ----- C1
- ⑩ to ⑭ ----- C2
- ⑮ to ⑳ ----- A3
- ㉑ ----- C2
- ㉒ to ㉓, ㉔ to ㉕ ----- A3
- ㉖ to ㉗ ----- B3
- ㉘ ----- B2
- ㉙, ㉚ ----- A2
- ㉛ to ㉜ ----- B3
- ㉝, ㉞ ----- B2
- ㉟ ----- C2
- ㊱ to ㊲ ----- A2
- ㊳ to ㊴ ----- A3
- ㊵ to ㊶ ----- B3
- ㊷ ----- B3
- ㊸, ㊹ ----- A3
- ㊺ to ㊻ ----- D2
- ㊼ to ㊽ ----- D2
- ㊾ ----- A3
- ㊿ to ① ----- D2

WARNING: Δ INDICATES SAFETY CRITICAL COMPONENTS. FOR CONTINUED SAFETY, REPLACE SAFETY CRITICAL COMPONENTS ONLY WITH MANUFACTURER'S RECOMMENDED PARTS.
AVERTISSEMENT: Δ IL INDIQUÉ LES COMPOSANTS CRITIQUES DE SÛRETÉ. POUR MAINTENIR LE DEGRÉ DE SÛRETÉ DE L'APPAREIL NE REMPLACER LES COMPOSANTS DONT LE FONCTIONNEMENT EST CRITIQUE POUR LA SÛRETÉ QUE PAR DES PIÈCES RECOMMANDÉES PAR LE FABRICANT

SYSCON PCB T2030B502A

CON P.C BOARD T2030B502C (2ED)

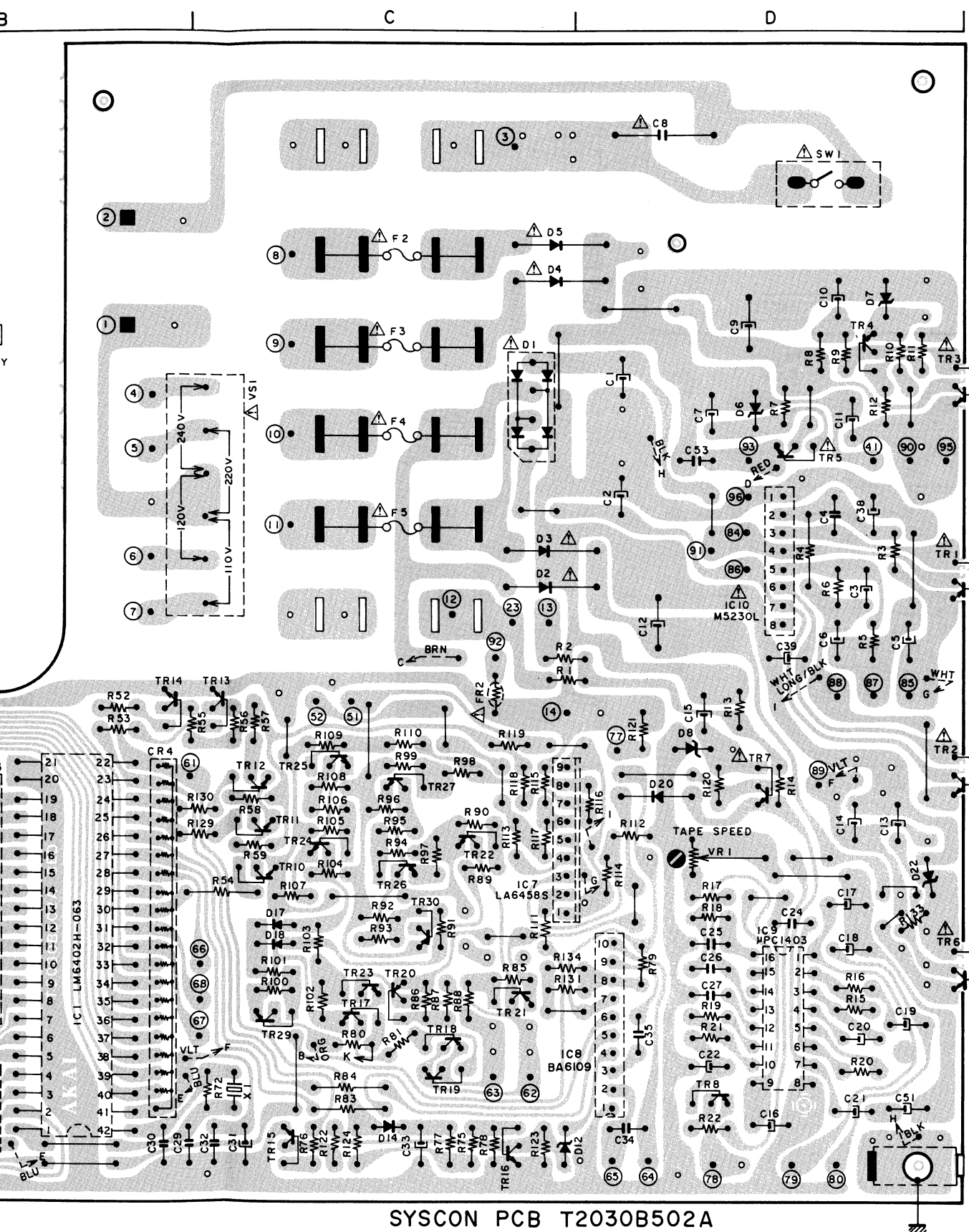

SYSCON PCB T2030B502A

U MODEL
POWER

LOCATION OF COMPONENTS

TR

- TR1, 2 ----- D2
- TR3, 4 ----- D1
- TR5 ----- D2
- TR6 ----- D3
- TR7 ----- D2
- TR8 ----- D3
- TR9 ----- B2
- TR10, 11 ----- C3
- TR12, 13 ----- C2
- TR14 ----- B2
- TR15 to 24 ----- C3
- TR25 ----- C2
- TR26 ----- C3
- TR27 ----- C2
- TR29, 30 ----- C3

IC

- IC1, 2 ----- B3
- IC3 to 6 ----- A3
- IC7 ----- C3
- IC8, 9 ----- D3
- IC10 ----- D2

TERMINAL

- ①, ② ----- B1
- ③ ----- C1
- ④ ----- B1
- ⑤ to ⑦ ----- B2
- ⑧, ⑨ ----- C1
- ⑩ to ⑭ ----- C2
- ⑮ to ⑰ ----- A3
- ⑱ ----- C2
- ⑳ to ㉓, ㉔ to ㉖ ----- A2
- ㉗ ----- B2
- ㉘ ----- D2
- ㉙, ㉚ ----- A2
- ㉛ to ㉝ ----- A3
- ㉞ to ㉟ ----- B3
- ㊱ ----- B2
- ㊲, ㊳ ----- C3
- ㊴, ㊵ ----- D3
- ㊶ to ㊸ ----- B3
- ㊹ ----- A3
- ㊺, ㊻ ----- A3
- ㊼ ----- D2
- ㊽ ----- B3
- ㊾ to ㊿ ----- D3
- ① to ② ----- D2
- ③ ----- C2
- ④ ----- D2
- ⑤ ----- A3
- ⑥ to ⑦ ----- D2

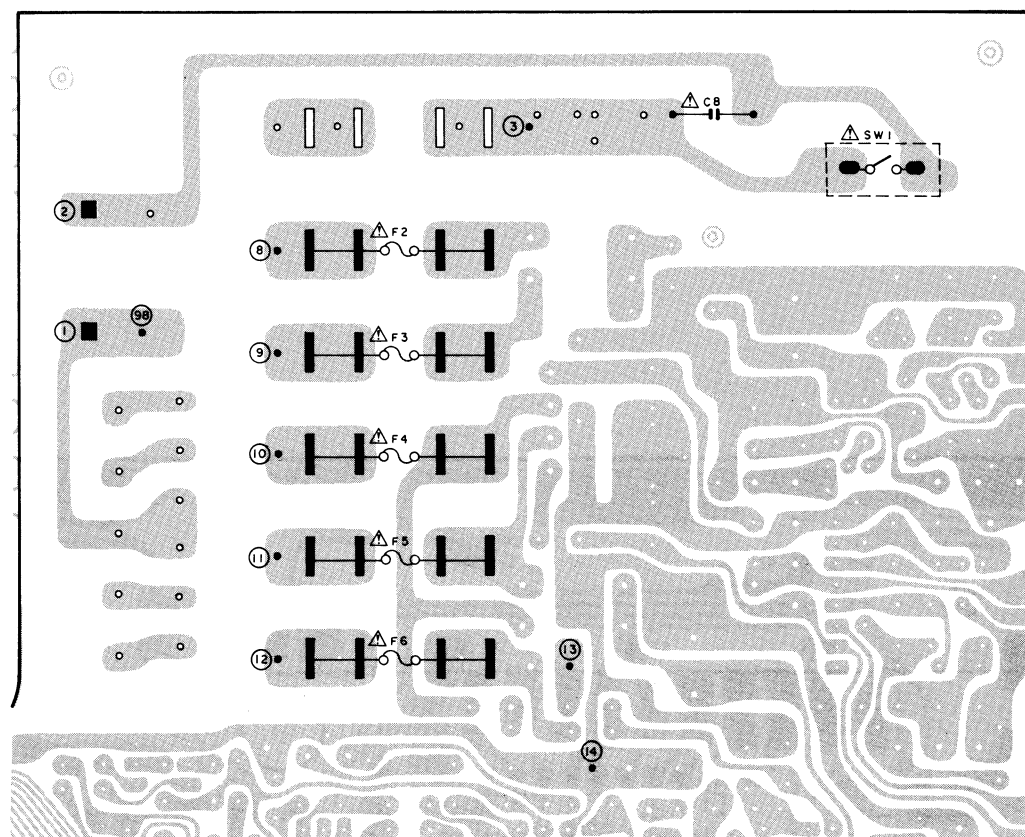

J,C,A,E,V,S MODEL
POWER

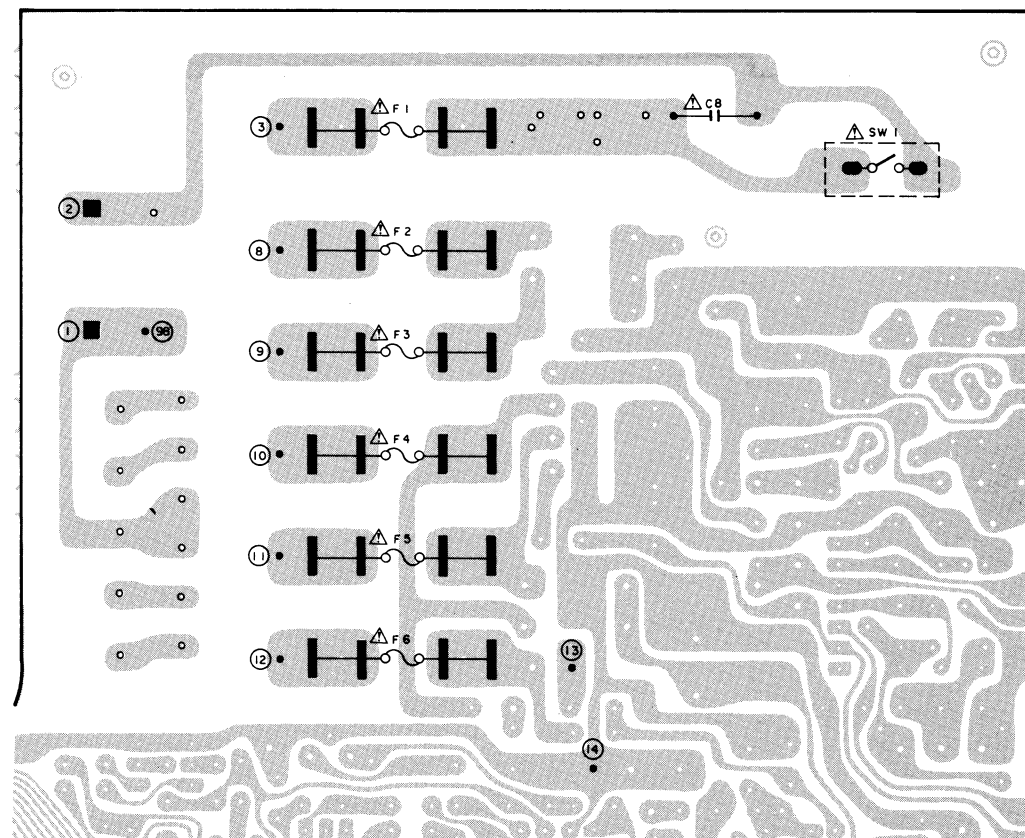

B MODEL
POWER

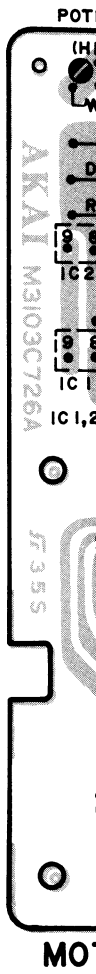
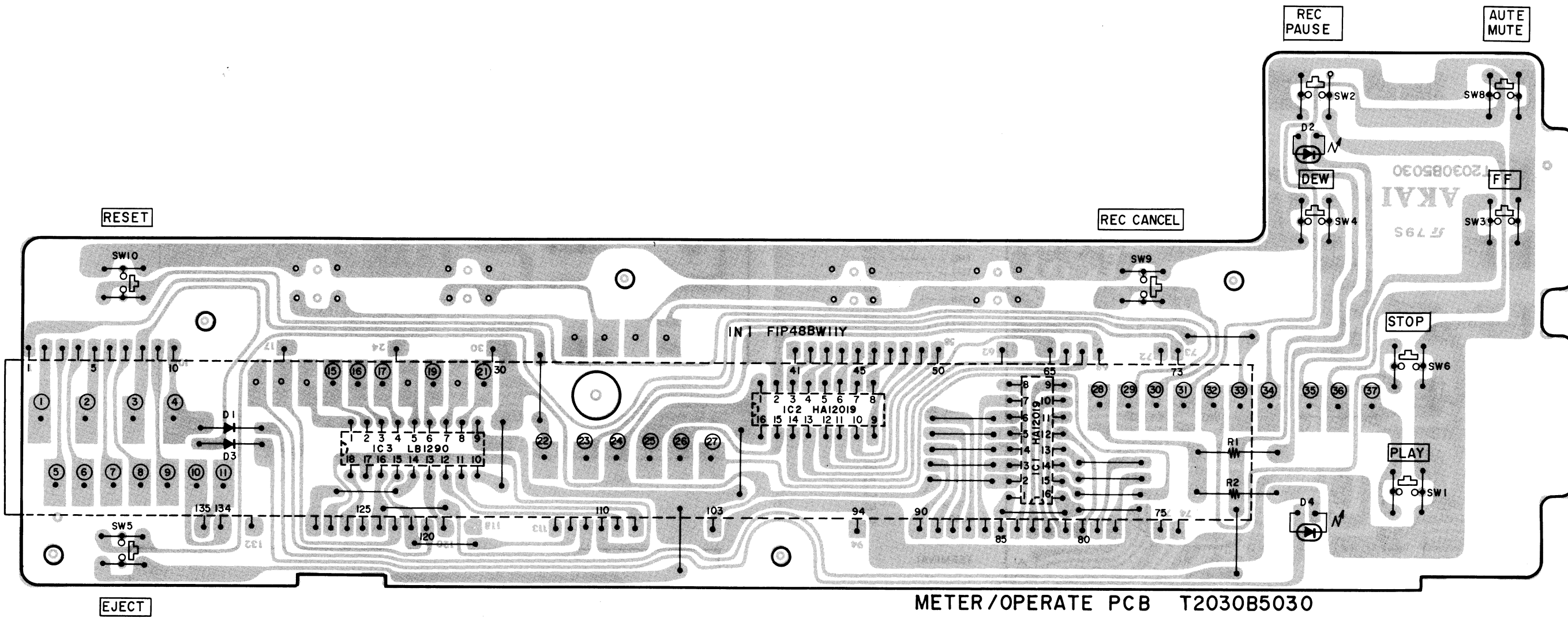

4) MOTOR P.C BOARD M3103C726A and POTENTION P.C BOARD M3103C726B

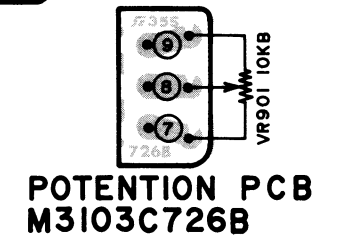
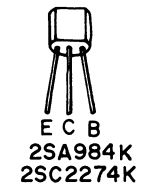
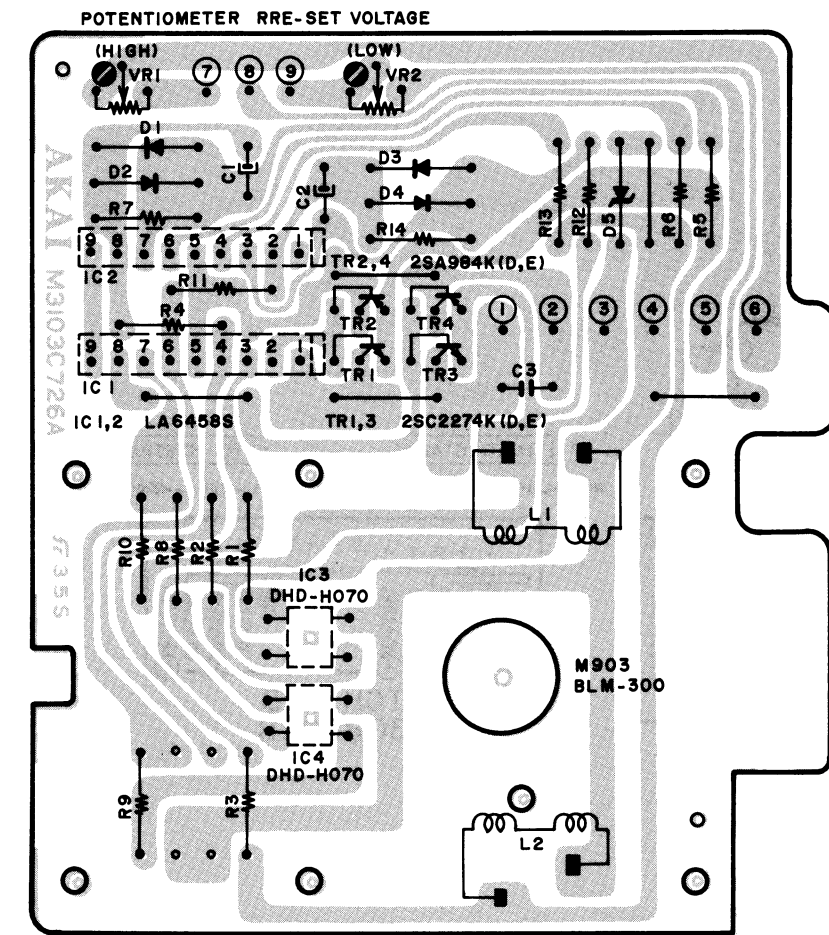
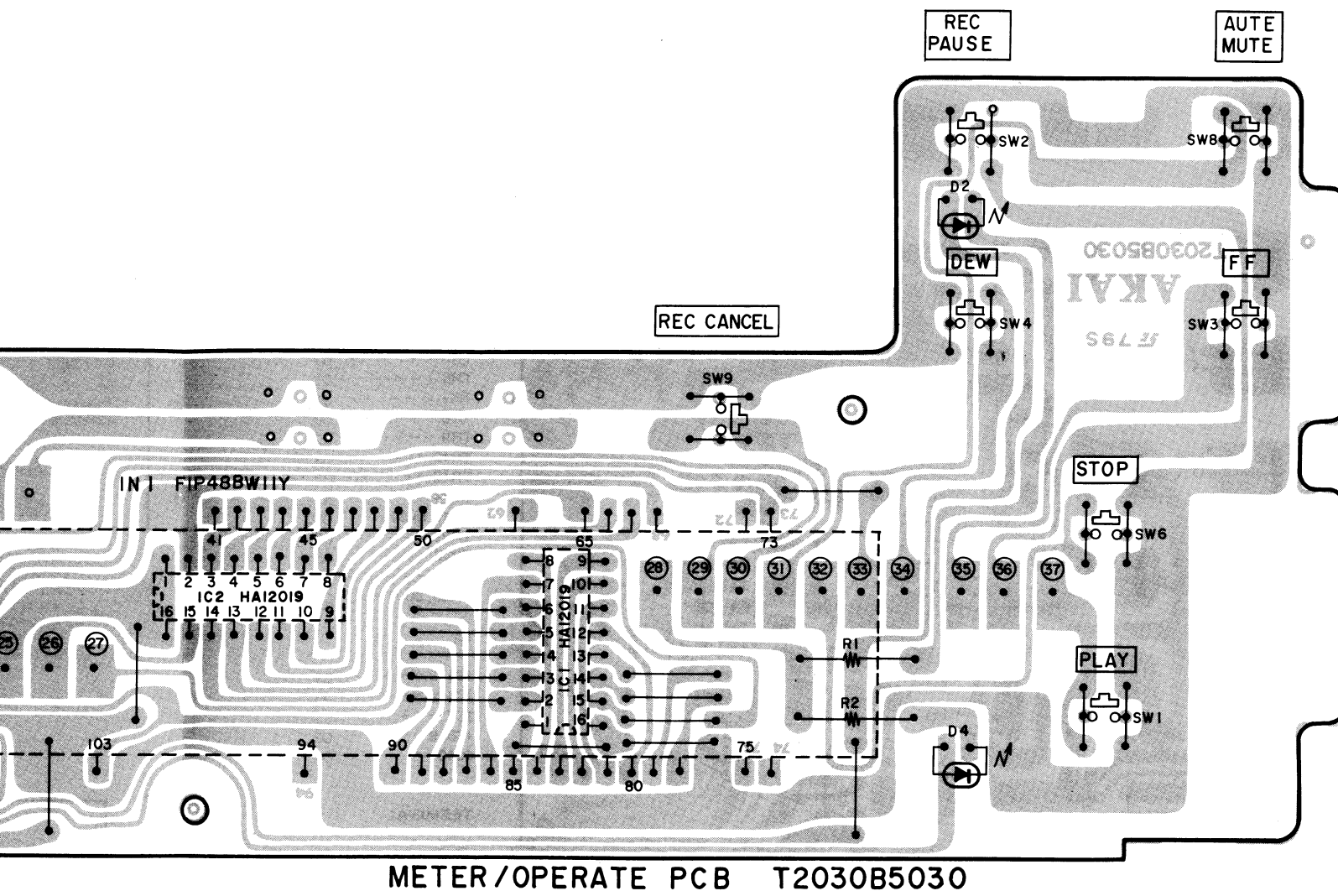

5) FG P.C BOARD M3103C7130

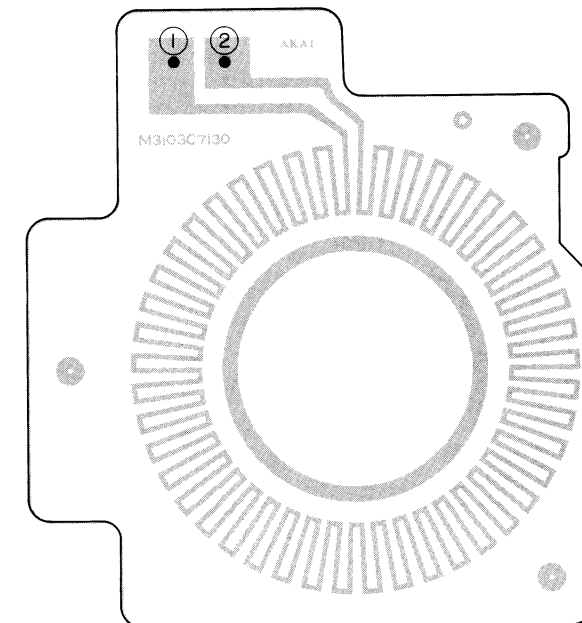

6) FILTER P.C BOARD T2029D5040

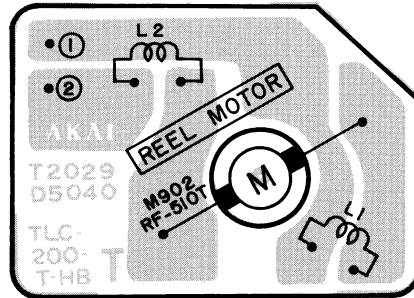

7) DETECTOR P.C BOARD T2029D5030

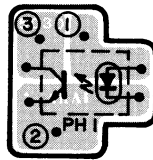

8) MICRO SW P.C BOARD T2029D5020

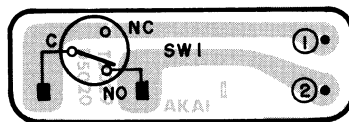



SECTION 3

SERVICE MANUAL

MODEL GX-F51

TABLE OF CONTENTS

I. SPECIFICATIONS	3- 2
II. CONTROLS	3- 3
III. PRINCIPAL PARTS LOCATION	3- 4
IV. VOLTAGE CONVERSION	3- 5
V. MECHANICAL ADJUSTMENT	3- 5
VI. HEAD ADJUSTMENT	3- 5
VII. AMPLIFIER ADJUSTMENT	3- 6
VIII. TUNING CIRCUIT ADJUSTMENT	3- 8
IX. DC RESISTANCE OF HEADS	3- 9
X. CLASSIFICATION OF VARIOUS P.C BOARDS	3- 9
1. P.C BOARD TITLES AND IDENTIFICATION NUMBERS	3- 9
2. COMPOSITION OF VARIOUS P.C BOARDS	3-10

For basic adjustments, measuring methods, and operating principles, refer to GENERAL TECHNICAL MANUAL.

I. SPECIFICATIONS

TRACK SYSTEM	4 Track 2 Channel Stereo System
TAPE	Philips Type Cassette
TAPE SPEED	4.76 cm/s \pm 1.0% (1-7/8 ips. \pm 1.0%)
HEADS	Twin Field Super GX head for recording/playback \times 1 Erase head \times 1
MOTORS	FG servo D.C. motor for direct capstan drive \times 1 D.C. motor for reel drive \times 1
WOW & FLUTTER	0.10% WTD (DIN) 0.035% WRMS
TAPE WINDING TIME	90 sec. using a C-60 cassette tape
FREQUENCY RESPONSE	Normal: 20 to 17,000 Hz \pm 3 dB (-20 VU) CrO ₂ : 20 to 18,000 Hz \pm 3 dB (-20 VU) Metal: 20 to 19,000 Hz \pm 3 dB (-20 VU)
FREQUENCY RANGE	Normal: 15 to 18,000 Hz CrO ₂ : 15 to 20,000 Hz Metal: 15 to 21,000 Hz
SIGNAL TO NOISE RATIO	Metal: Better than 60 dB (measured via tape with peak recording level) Dolby B-type NR switch ON: Improves up to 5 dB at 1 kHz, 10 dB above 5 kHz Dolby C-type NR switch ON: Improves up to 15 dB at 500 Hz, 20 dB at 1 kHz to 10 kHz
HARMONIC DISTORTION	1 kHz, 3rd harmonic distortion Metal: Less than 0.8%
INPUT	MIC: 0.25 mV (input impedance 5.0 kohms) Required microphone impedance: 600 ohms Line: 70 mV (input impedance: 47 kohms)
OUTPUT	Line: 410 mV at 0 VU Required load impedance: 2.0 kohms Phone: 1.3 mW/8 ohms at 0 VU
DIN	Input: 2.0 mV Output: 410 mV Required impedance: more than 20 kohms
POWER REQUIREMENTS	100V, 50/60 Hz for Japan 120V, 60 Hz for USA and Canada 220V, 50 Hz for Europe except UK 240V, 50 Hz for UK and Australia 110V/120V/220V/240V, 50/60 Hz switchable for other countries.
POWER CONSUMPTION	U, C, A Model: 24W J Model: 22W
DIMENSIONS	440(W) \times 100(H) \times 345(D) mm (17.3 \times 3.9 \times 13.6")
WEIGHT	6.1 kg (13.4 lbs)

* For improvement purposes, specifications and design are subject to change without notice.

* "Dolby" and the Double D symbol are trademarks of Dolby Laboratories.
(Manufactured under license from Dolby Laboratories).

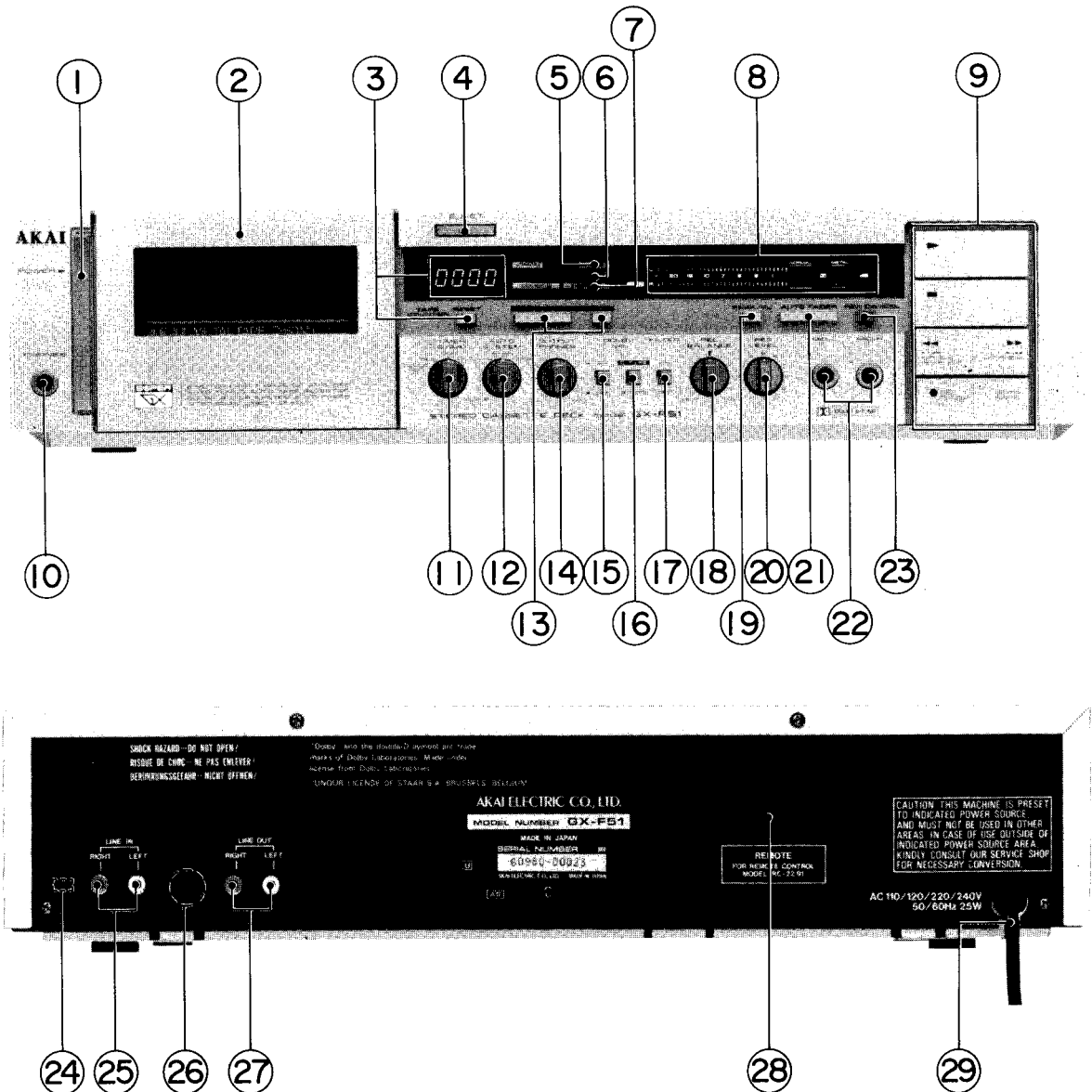

Fig. 1 Controls

- | | |
|---|--|
| <ol style="list-style-type: none"> 1. POWER SWITCH 2. CASSETTE RECEPTACLE 3. FLD TAPE COUNTER and RESET BUTTON 4. EJECT BUTTON 5. TAPE POSITION INDICATORS 6. AUTO TAPE TUNING INDICATORS 7. DOLBY B and DOLBY C INDICATORS 8. FLD BAR METER with MAXIMUM INPUT LEVEL INDICATORS 9. OPERATING BUTTONS
PLAY (▶) BUTTON with INDICATOR
STOP (■) BUTTON
REWIND (◀◀) BUTTON
FAST FORWARD (▶▶) BUTTON
RECORDING (REC)/PAUSE BUTTON with INDICATOR
AUTO MUTE BUTTON 10. HEADPHONE (PHONES) JACK 11. TIMER START SELECTOR 12. AUTO SYSTEM SELECTOR 13. TUNING and REFERENCE (REF) BUTTONS | <ol style="list-style-type: none"> 14. OUTPUT/HEADPHONE (PHONES) CONTROL 15. DOLBY NR SWITCH 16. DOLBY NR SELECTOR 17. MPX FILTER SWITCH 18. RECORDING (REC) BALANCE CONTROL (LEFT and RIGHT) 19. PEAK/VU SELECTOR 20. RECORDING (REC) LEVEL CONTROL 21. AUTO FADER BUTTON 22. MICROPHONE JACKS (MIC-L: left, MIC-R: right) 23. RECORDING (REC) CANCEL BUTTON 24. LINE/DIN SELECTOR
(Some models do not have this facility.) 25. LINE IN JACKS 26. DIN JACK
(Some models are not equipped with this facility.) 27. LINE OUT JACKS 28. REMOTE JACK 29. POWER CORD |
|---|--|

III. PRINCIPAL PARTS LOCATION

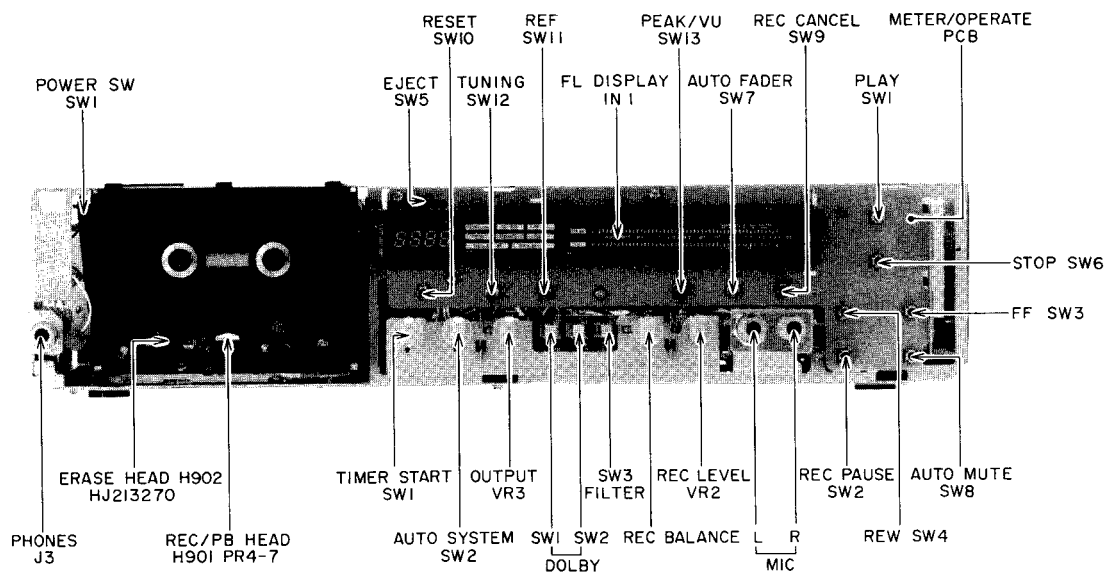

Fig. 2 Front View

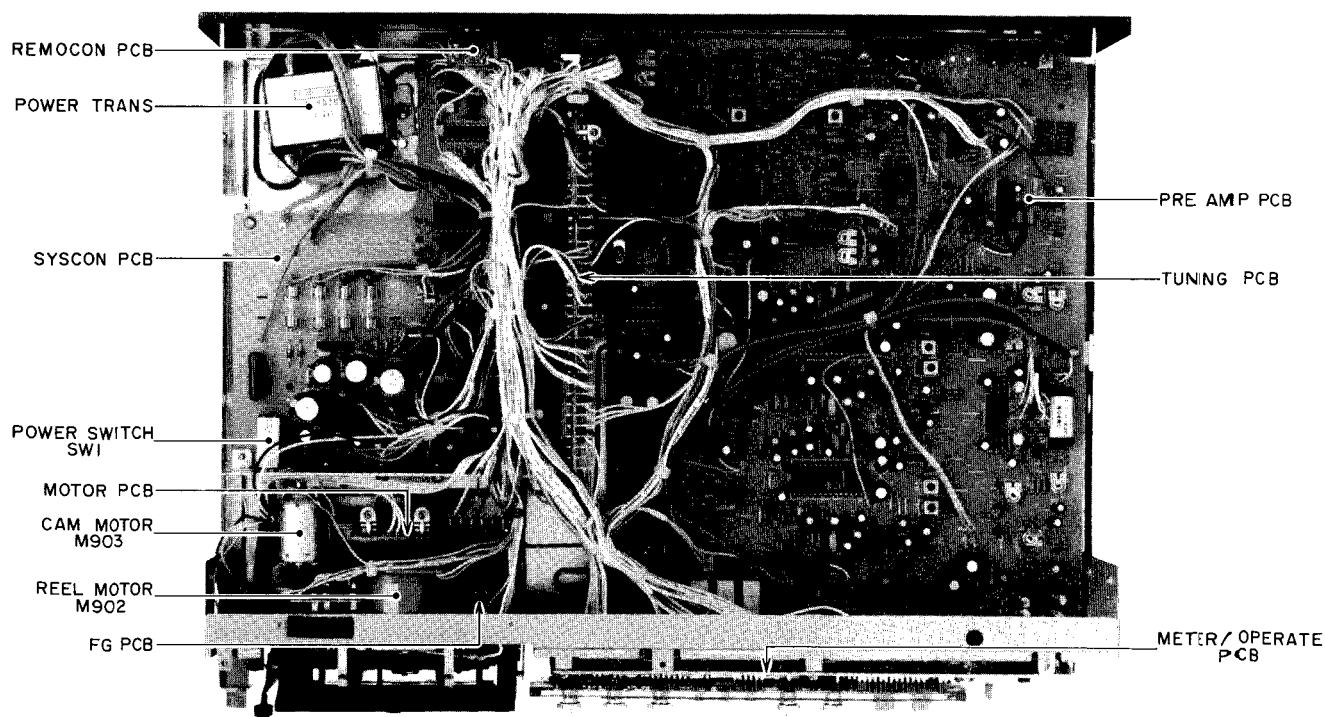

Fig. 3 Top View

IV. VOLTAGE CONVERSION

Refer to Section 2-IV (GX-F31)

V. MECHANICAL ADJUSTMENT

Refer to Section 2-V (GX-F31)

VI. HEAD ADJUSTMENT

Refer to Section 2-VI (GX-F31)

VII. AMPLIFIER ADJUSTMENT

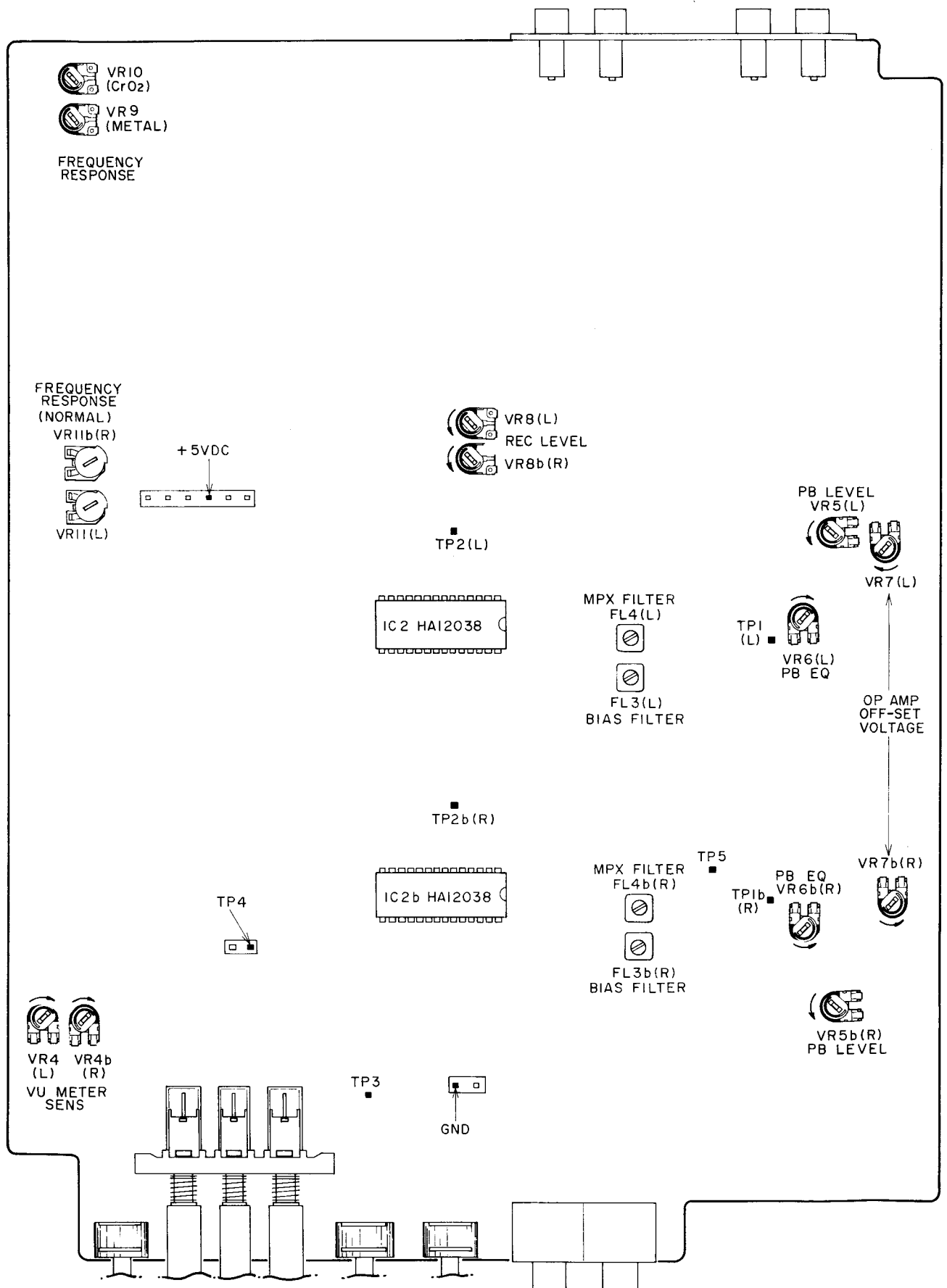

Fig. 4 Pre Amp P.C Board

Step	Adjustment Item	Test Tape Supply Signal	Mode	Adjustment Parts	Result	Remarks
1	OP Amp Off-Set Voltage		STOP	VR7 Pre Amp PCB	TP1 0 ± 0.1 VDC	
2	PB Level	333 Hz Test Tape (TF-101CL)	PB	VR5 Pre Amp PCB	-5.5 ± 0.5 dBm (410 mV)	
3	PB EQ	10 kHz Test Tape (TF-106CH)	PB	VR6 Pre Amp PCB	-22.5 ± 1.5 dBm	
4	Normal Position Frequency Response	Normal Blank Tape 1 kHz, 10 kHz -25.5 dBm	REC/PB	VR11 Pre Amp PCB	1 kHz to 10 kHz flat response	
5	CrO ₂ Position Frequency Response	CrO ₂ Blank Tape 1 kHz, 10 kHz -25.5 dBm	REC/PB	VR10 Pre Amp PCB	1 kHz to 10 kHz flat response	
6	Metal Position Frequency Response	Metal Blank Tape 1 kHz, 10 kHz -25.5 dBm	REC/PB	VR9 Pre Amp PCB	1 kHz to 10 kHz flat response	
7	REC Level	Normal Blank Tape 1 kHz, -5.5 dBm	REC/PB	VR8 Pre Amp PCB	-5.5 ± 0.3 dBm (410 mV)	
8	MPX Filter	19 kHz from oscillator	REC	FL4 Pre Amp PCB	Minimum Output	MPX Filter ON
9	Bias Filter	No Signal Input	REC	FL3 Pre Amp PCB	Minimum Output	Set REC Volume to maximum
10	VU Meter Sensitivity	1 kHz, -5.5 dBm from oscillator	REC	VR4 Pre Amp PCB	0 dB (VU) indication	

- NOTES:**
- Output volume should be at maximum.
 - Dolby NR Switch to OFF Position.
 - Except for Step 8 set Dolby Filter Switch to OFF Position.
 - Use the following cassette measuring tapes:
 - Normal Tape : Maxell UD C-60
 - CrO₂ Tape : TDK SA C-60
 - Metal Tape : TDK MA-C C-60

For your reference:

Confirmation of Dolby level

- Set to REC/PAUSE.
- Input a signal of 400 Hz and adjust the input level so that the level of pin ④ of Dolby I.C (HA-12038) will be 580 mV when Dolby NR is OFF.
- Check that the level of TP-2 is 580 mV.

VIII. TUNING CIRCUIT ADJUSTMENT

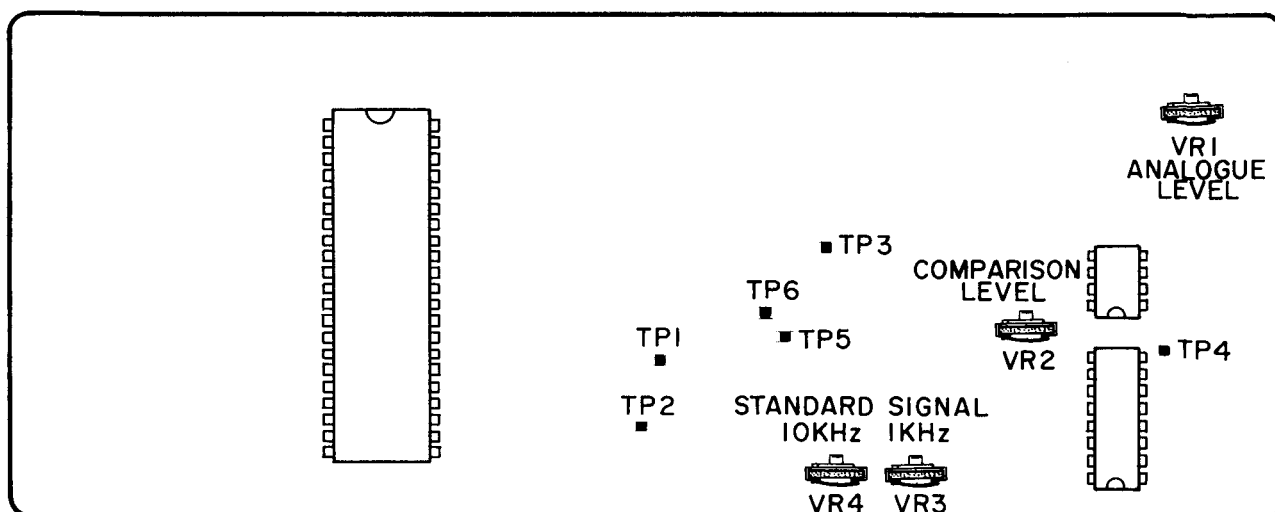

Fig. 5 Tuning P.C Board

- 1) Standard Signal (1 kHz) output Adjustment
 - a. Set to REC/PAUSE.
 - b. Apply +5V DC to TP3 of the Pre Amp PCB.
 - c. Input square wave of 3Vp-p or more, 1057 ± 10 Hz, into TP-1 of the tuning PCB.
 - d. Adjust VR3 of the tuning PCB so that the level of TP4 of Pre Amp PCB will be -25.5 ± 0.1 dBm.
- 2) Standard Signal (10 kHz) Output Adjustment
 - a. Set to REC/PAUSE.
 - b. Apply +5V DC to TP3 of Pre Amp PCB.
 - c. Input square wave of 3Vp-p or more, 9941 ± 100 Hz, into TP2 of the tuning PCB.
 - d. Adjust VR4 of the tuning PCB so that the level of TP4 of Pre Amp PCB will be -24.0 ± 0.1 dBm.
- 3) A/D Converter Analogue Level Adjustment
 - a. Set to PLAY mode without inserting a tape.
 - b. Input a signal of 1 kHz into TP5 of Pre Amp PCB and adjust the input level so that TP4 of Pre Amp PCB will be -25.5 dBm.
 - c. Adjust VR1 of the tuning PCB so that the level of TP3 of the tuning PCB will be 3.49 ± 0.05 V DC.
- 4) A/D Converter Comparison Level Adjustment
 - a. Connect TP5 and TP6 of the tuning PCB to GND.
 - b. Adjust VR2 of the tuning PCB so that the level of TP4 of the tuning PCB will be 3.70 ± 0.05 V DC.

NOTE: A digital voltmeter should be used for the measurement of DC voltage and an AC voltmeter (mV meter) for the measurement of AC voltage, and the input impedance should be 10M ohm or more.

IX. DC RESISTANCE OF HEADS

GX-F51

Description	Name	DC Resistance
REC/PB Head	PR4-7	650 ohms \pm 10%
Erase Head	HJ213270	3.5 ohms

X. CLASSIFICATION OF VARIOUS P.C BOARDS

1. P.C BOARD TITLES AND IDENTIFICATION NUMBERS

P.C Board Title	P.C Board Number
Pre Amp P.C Board	T2030A501A
Phone Jack P.C Board	T2030A501B
Tuning P.C Board	T2030C5040
Syscon P.C Board	T2030B502A
Switch P.C Board	T2030B502B
Remocon P.C Board	T2030B502C
Meter/Operate P.C Board	T2030B5030
Motor P.C Board	T3103C726A
Potention P.C Board	M3103C726B
FG P.C Board	M3103C7130
Filter P.C Board	T2029D5040
Detector P.C Board	T2029D5030
Micro SW P.C Board	T2029D5020

2. COMPOSITION OF VARIOUS P.C BOARDS

1) PRE AMP P.C BOARD T2030A501A (2ED) and PHONE JACK P.C BOARD T2030A501B

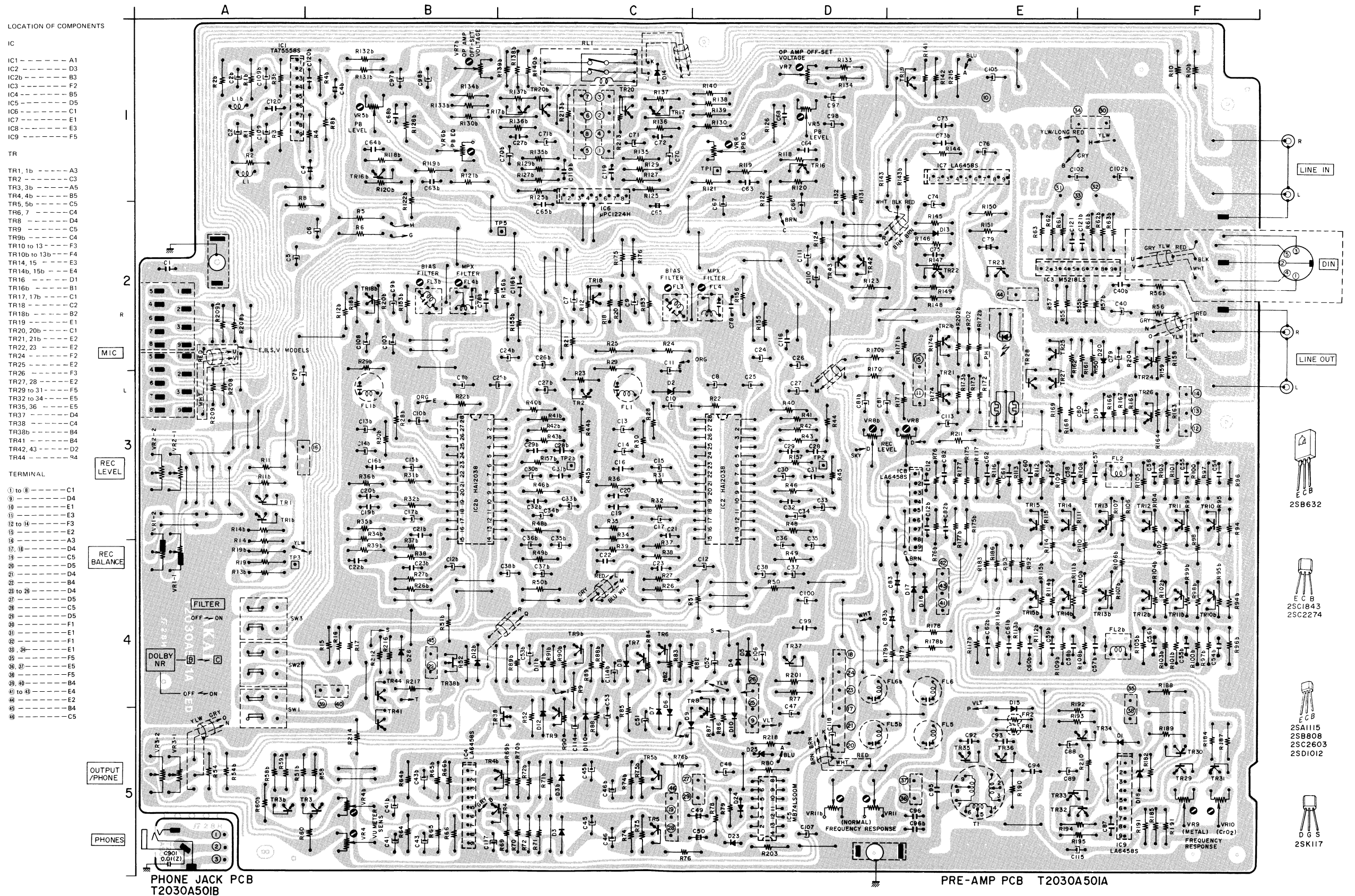

LOCATION OF COMPONENTS

IC

- IC1 ----- A1
- IC2 ----- D3
- IC3 ----- B3
- IC4 ----- F2
- IC5 ----- D5
- IC6 ----- C1
- IC7 ----- E1
- IC8 ----- E3
- IC9 ----- F5

TR

- TR1, 1b ----- A3
- TR2 ----- C3
- TR3, 3b ----- A5
- TR4, 4b ----- B5
- TR5, 5b ----- C5
- TR6, 7 ----- C4
- TR8 ----- D4
- TR9 ----- C5
- TR9b ----- C4
- TR10 to 13 ----- F3
- TR10b to 13b ----- F4
- TR14, 15 ----- E3
- TR14b, 15b ----- E4
- TR16 ----- D1
- TR16b ----- B1
- TR17, 17b ----- C1
- TR18 ----- C2
- TR18b ----- B2
- TR19 ----- E1
- TR20, 20b ----- C1
- TR21, 21b ----- E2
- TR22, 23 ----- E2
- TR24 ----- F2
- TR25 ----- E2
- TR26 ----- F3
- TR27, 28 ----- E2
- TR29 to 31 ----- F5
- TR32 to 34 ----- E5
- TR35, 36 ----- E5
- TR37 ----- D4
- TR38 ----- C4
- TR38b ----- B4
- TR41 ----- B4
- TR42, 43 ----- D2
- TR44 ----- B4

TERMINAL

- ① to ⑧ ----- C1
- ⑨ ----- D4
- ⑩ ----- E1
- ⑪ ----- E3
- ⑫ to ⑭ ----- F3
- ⑮ ----- E2
- ⑯ ----- A3
- ⑰, 18 ----- D4
- ⑱ ----- C5
- ⑲ ----- D5
- ⑳ to 26 ----- D4
- 27 ----- D5
- 28 ----- C5
- 29 ----- D5
- 30 ----- F1
- 31 ----- E1
- 32 ----- F1
- 33, 36 ----- E1
- 34 ----- F5
- 35 ----- E5
- 36 ----- F5
- 37 ----- B4
- 38 to 43 ----- E4
- 44 ----- E2
- 45 ----- B4
- 46 ----- C5

MIC

REC LEVEL

REC BALANCE

OUTPUT /PHONE

PHONES

PHONE JACK PCB
T2030A501B

PRE-AMP PCB T2030A501A

- TR1, 17, 19 to 21, 42 ----- 2SD1012V(G, H)
- TR2 to 6, 9, 16, 22 to 29, 31, 34, 41, 44 ----- 2SC2603(E, F)
- TR7, 8, 30 ----- 2SA1115(E, F)
- TR18 ----- 2SC1843(E, F)
- TR32 ----- 2SB632K(E, F)
- TR33 ----- 2SC1843(P, F)
- TR35 to 37 ----- 2SC2274(K, E)
- TR38 ----- 2SK117(GR, BL)
- T43 ----- 2SB808V(F, G)
- 2SA1115
- 2SB808
- 2SC2603
- 2SD1012
- DGS
- 2SK117

2) SYSCON P.C BOARD T2030B502A (3ED), SWITCH P.C BOARD T2030B502B and REMOCON P.C BOARD T2030B502C (2ED)

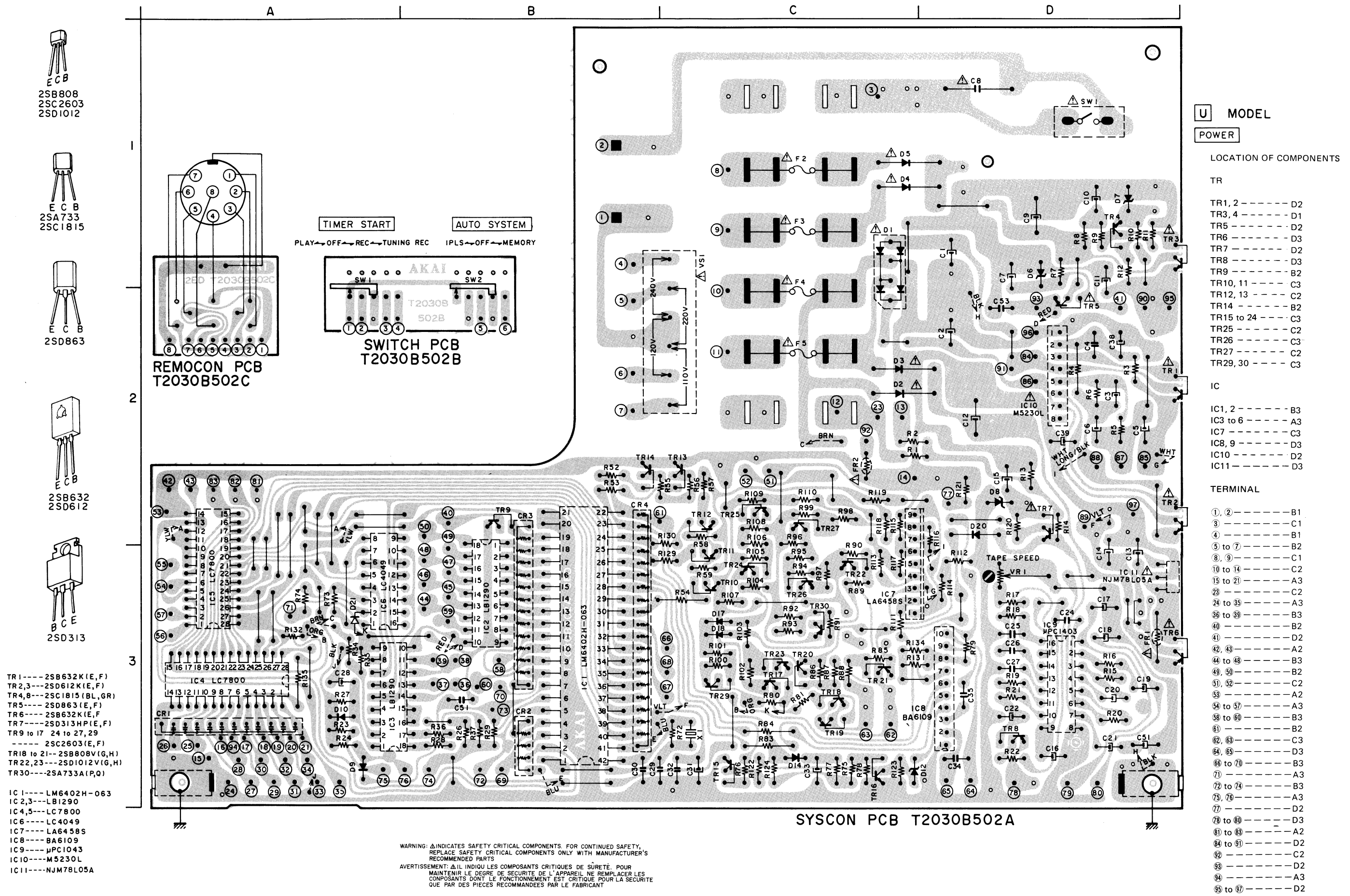

ON P.C BOARD T2030B502C (2ED)

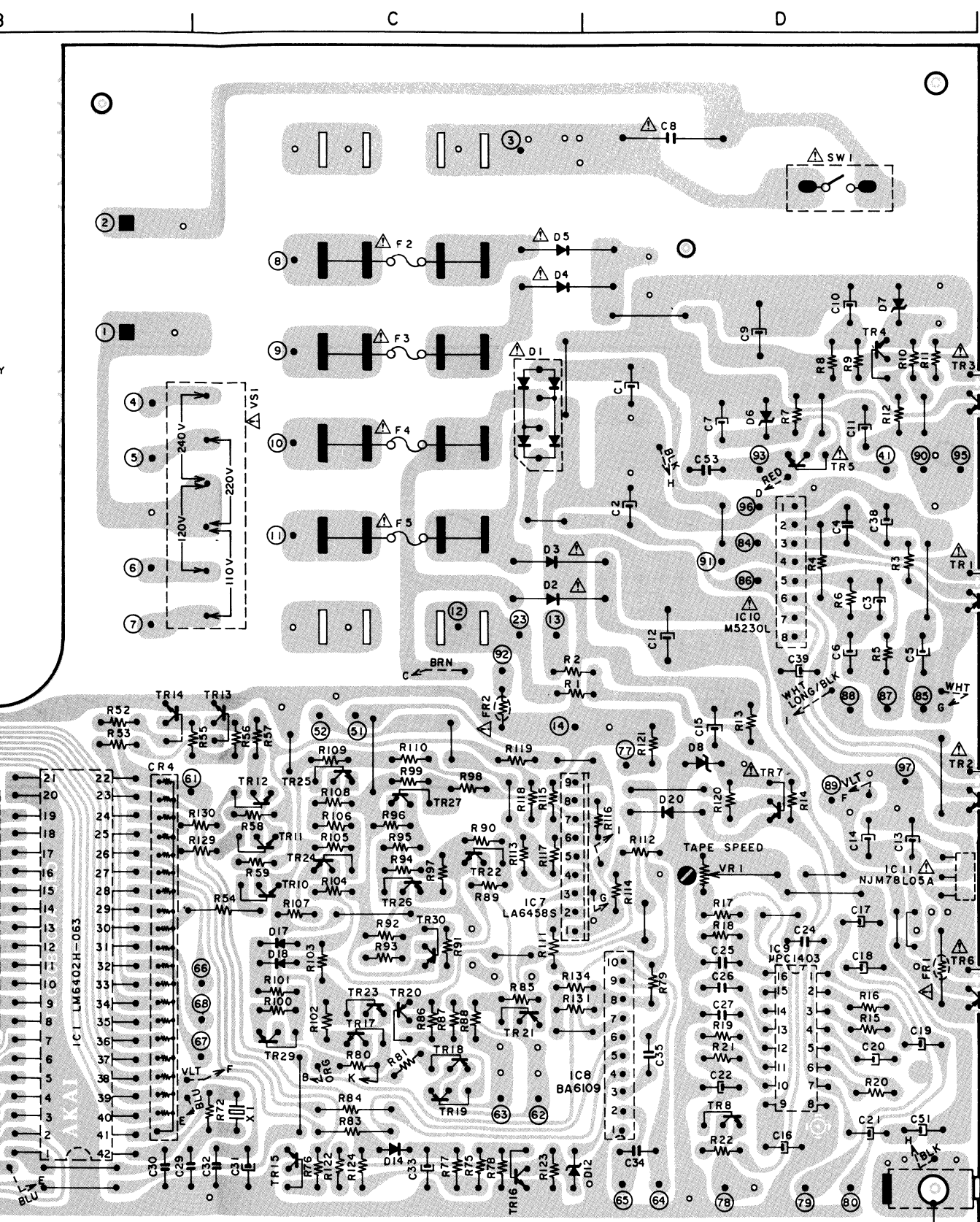

SYSCON PCB T2030B502A

COMPONENTS. FOR CONTINUED SAFETY,
REPLACE ONLY WITH MANUFACTURER'S
EQUIVALENTS. CRITIQUES DE SÛRETÉ. POUR
REPLACER L'APPAREIL NE REMPLACER LES
COMPONENTS CRITIQUES. POUR LA SÛRETÉ
REPLACER SEULEMENT PAR LE FABRICANT

U MODEL

POWER

LOCATION OF COMPONENTS

- TR
- TR1, 2 ----- D2
 - TR3, 4 ----- D1
 - TR5 ----- D2
 - TR6 ----- D3
 - TR7 ----- D2
 - TR8 ----- D3
 - TR9 ----- B2
 - TR10, 11 ----- C3
 - TR12, 13 ----- C2
 - TR14 ----- B2
 - TR15 to 24 ----- C3
 - TR25 ----- C2
 - TR26 ----- C3
 - TR27 ----- C2
 - TR29, 30 ----- C3
- IC
- IC1, 2 ----- B3
 - IC3 to 6 ----- A3
 - IC7 ----- C3
 - IC8, 9 ----- D3
 - IC10 ----- D2
 - IC11 ----- D3

TERMINAL

- ①, ② ----- B1
- ③ ----- C1
- ④ ----- B1
- ⑤ to ⑦ ----- B2
- ⑧, ⑨ ----- C1
- ⑩ to ⑭ ----- C2
- ⑮ to ⑳ ----- A3
- ㉑ ----- C2
- ㉒ to ㉓ ----- A3
- ㉔ ----- B2
- ㉕ ----- D2
- ㉖, ㉗ ----- A2
- ㉘ to ㉙ ----- B3
- ㉚, ㉛ ----- B2
- ㉜ to ㉝ ----- A3
- ㉞ to ㉟ ----- B3
- ㊱ ----- B2
- ㊲, ㊳ ----- C3
- ㊴, ㊵ ----- D3
- ㊶ to ㊷ ----- B3
- ㊸ ----- A3
- ㊹ to ㊺ ----- B3
- ㊻, ㊼ ----- A3
- ㊽ ----- D2
- ㊾ to ㊿ ----- D3
- ① to ③ ----- A2
- ④ to ⑥ ----- D2
- ⑦ ----- C2
- ⑧ ----- D2
- ⑨ ----- A3
- ⑩ to ⑫ ----- D2

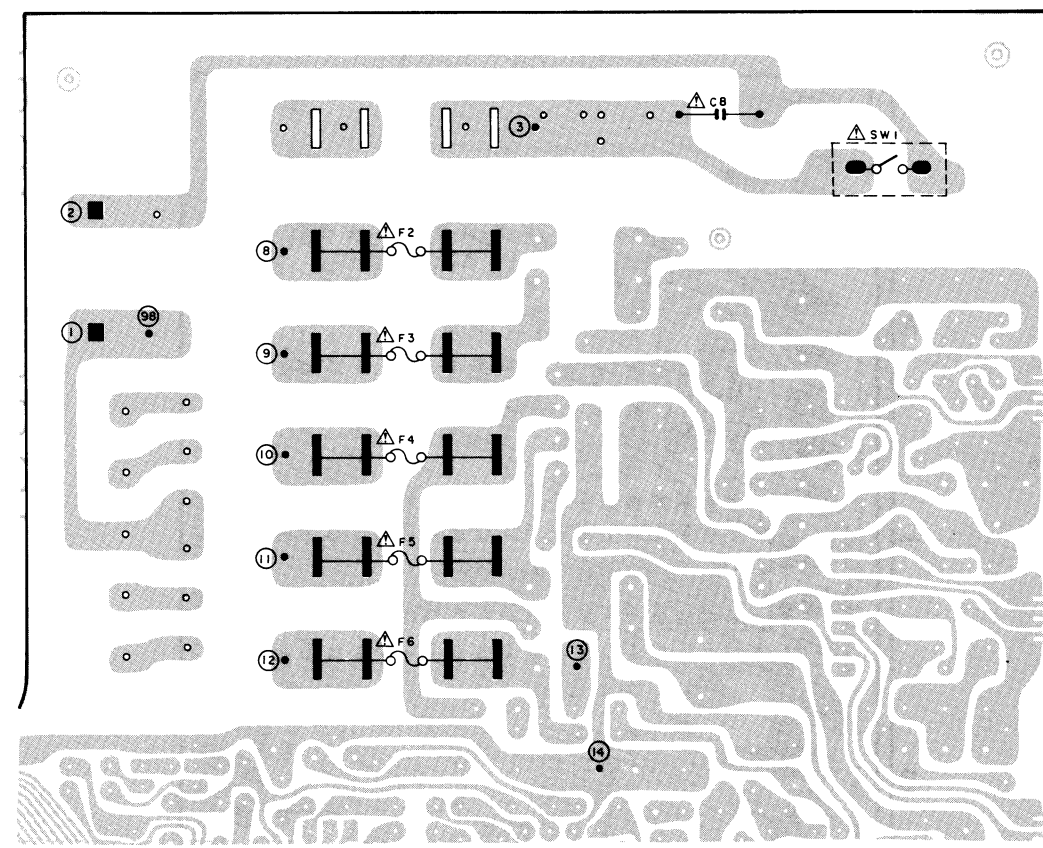

J,C,A,E,V,S MODEL

POWER

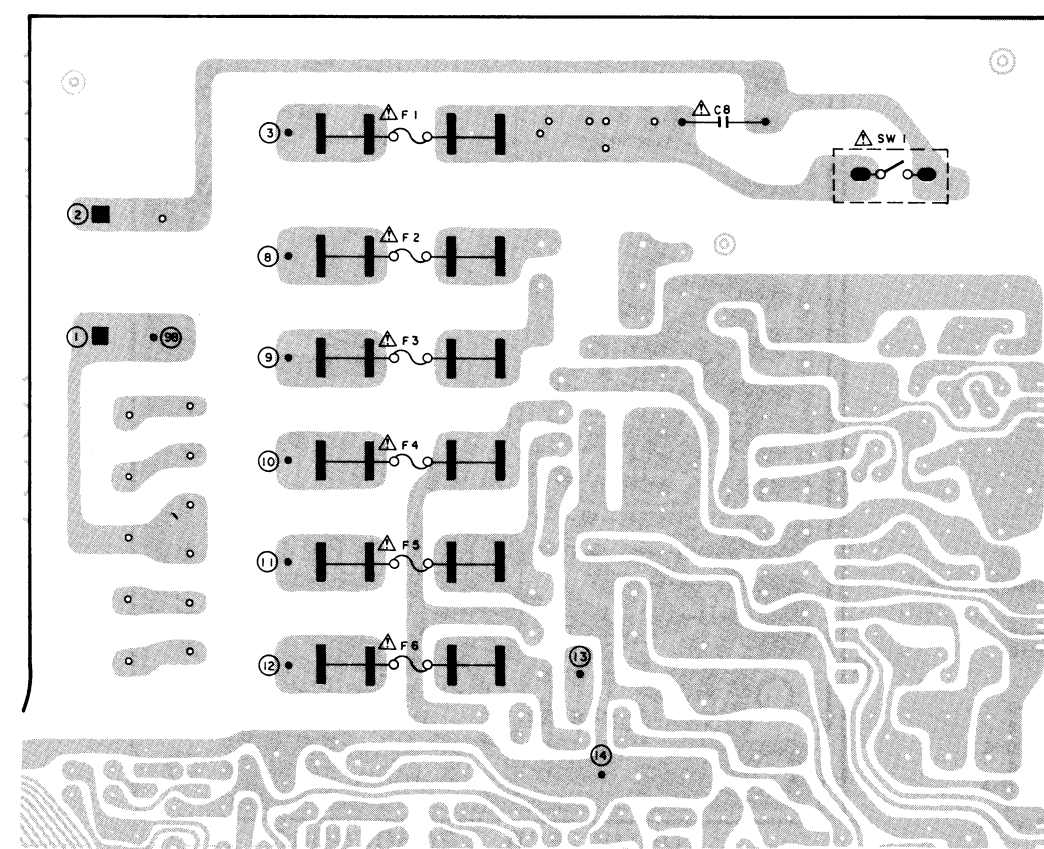

B MODEL

POWER

3) TUNING P.C BOARD T2030C5040 (2ED)

4) METER/OPERATE P.C BOARD T2030B5030

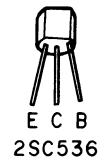
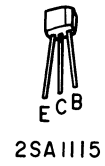

TR1 to 6, 10 to 18, 21, 22
2SC536K-NP (E,F)
TR7 to 9, 19, 20
2SA1115 (E,F)

LOCATION OF COMPONENTS

IC
IC1 — B
IC2,3 — D

TR
TR1 — D
TR2,3 — B
TR4 to 10 — C
TR11 — B
TR12 to 17 — A
TR18 — B
TR19 to 22 — C

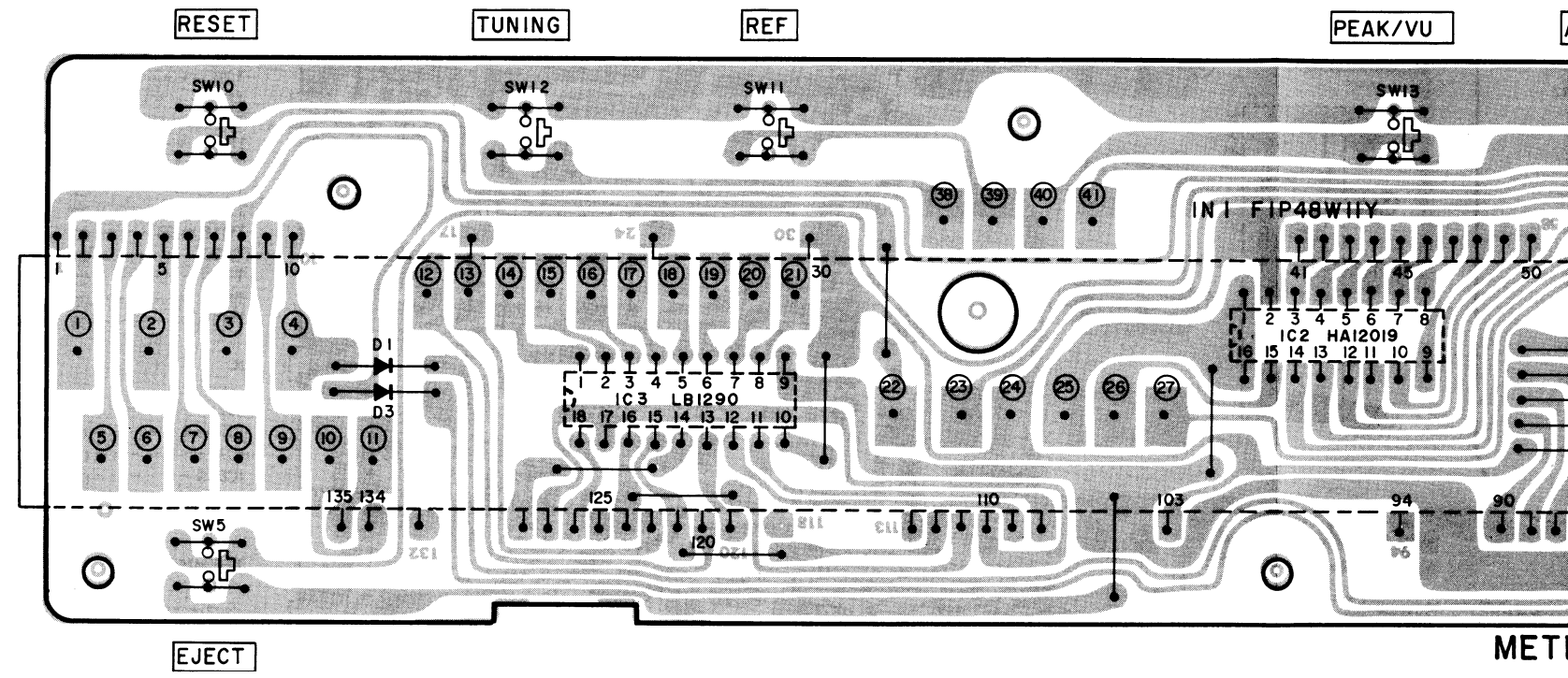
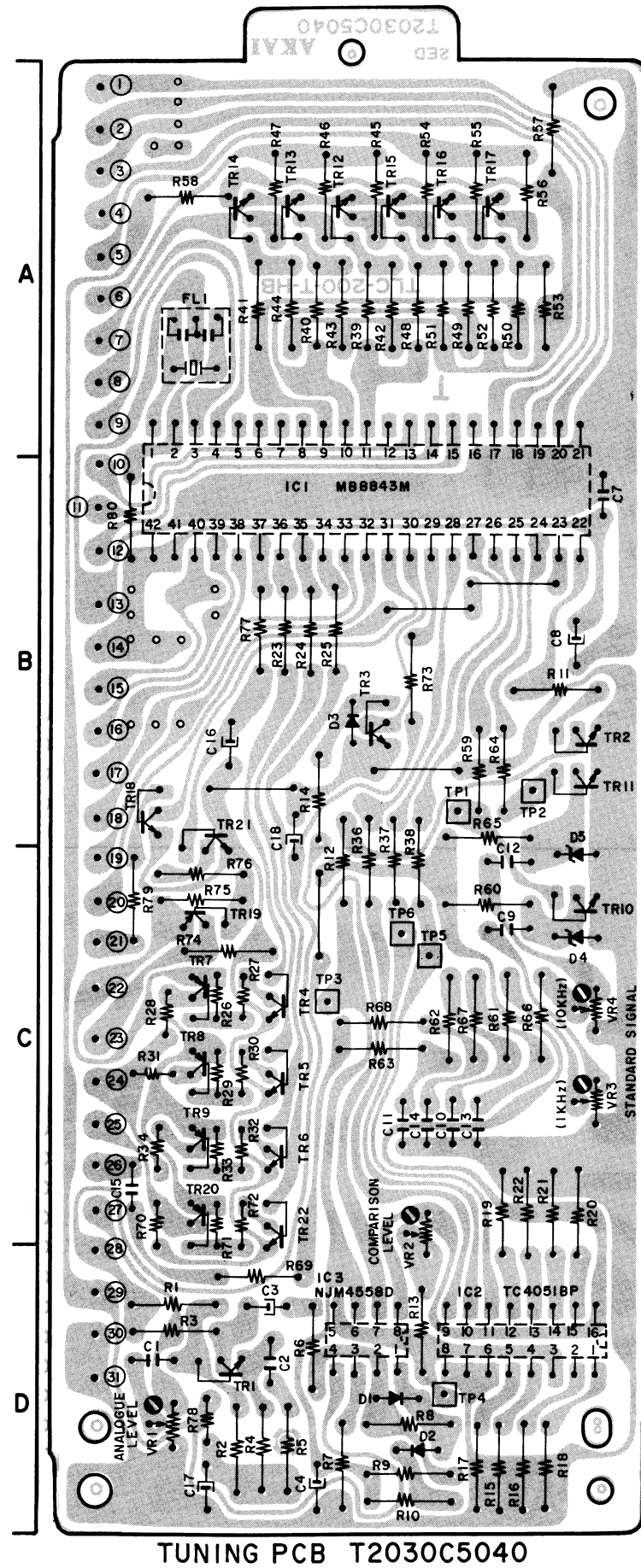

4) METER/OPERATE P.C BOARD T2030B5030

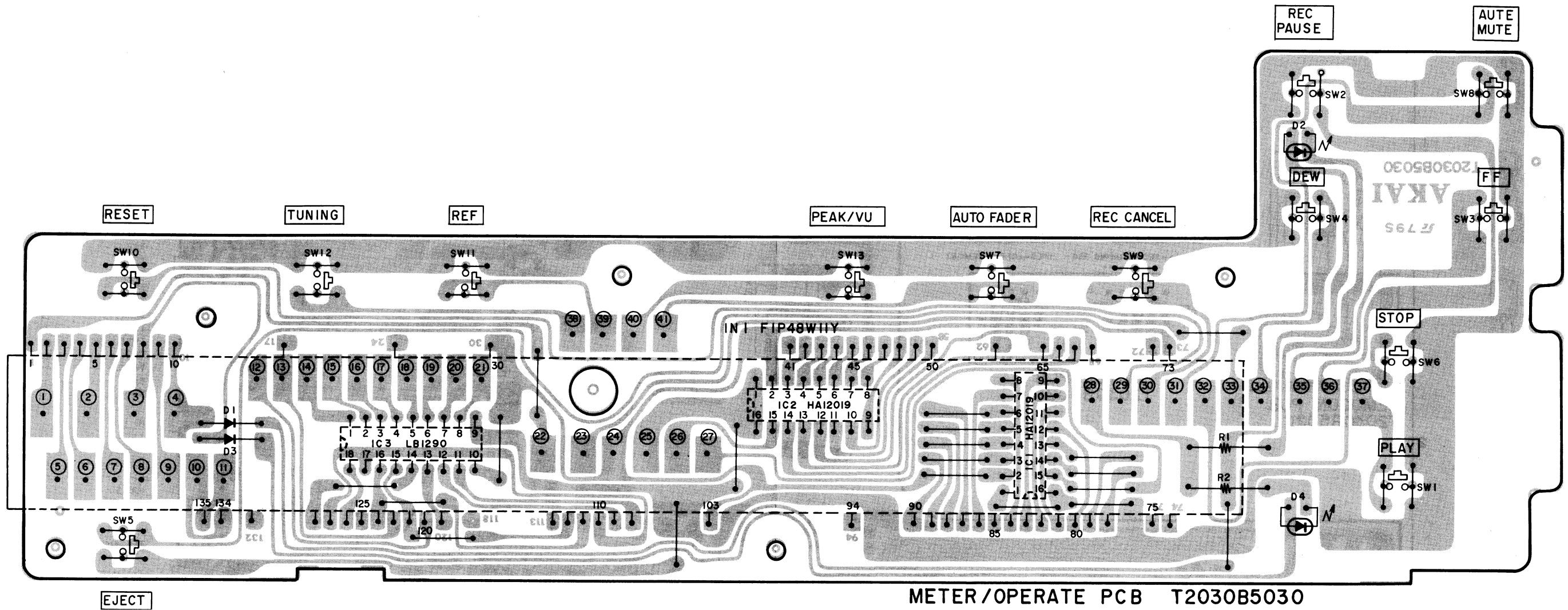

METER/OPERATE PCB T2030B5030

5) MOTOR P.C BOARD M3103C726A and POTENTION P.C BOARD M3103C726B

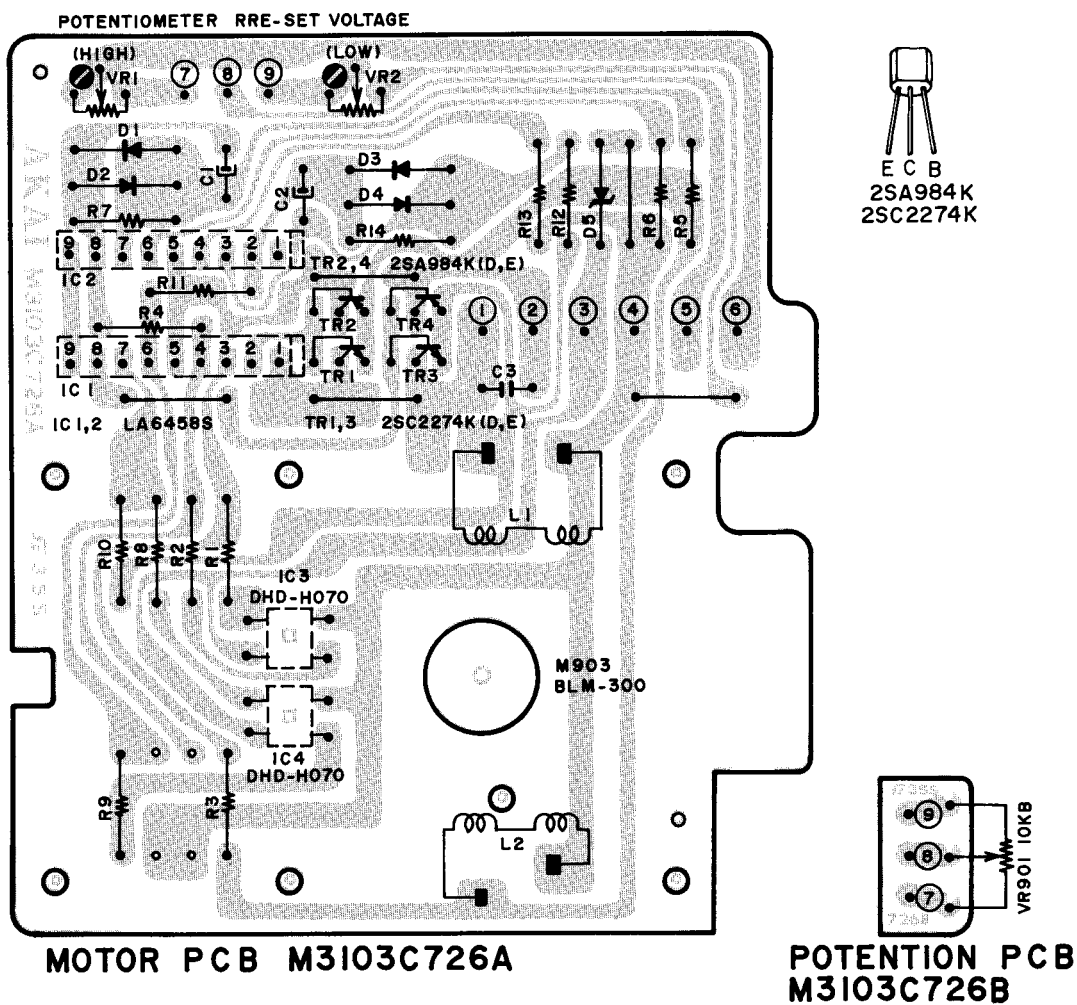

6) FG P.C BOARD M3103C7130

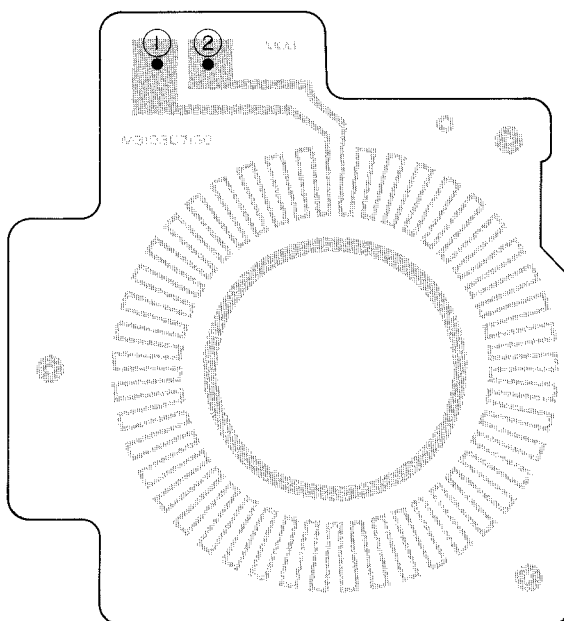

7) FILTER P.C BOARD T2029D5040

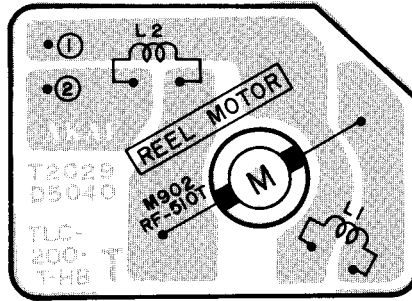

8) DETECTOR P.C BOARD T2029D5030

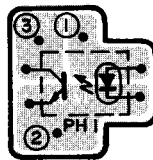

9) MICRO SW P.C BOARD T2029D5020

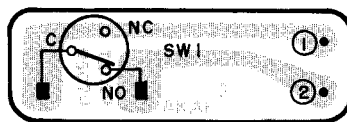

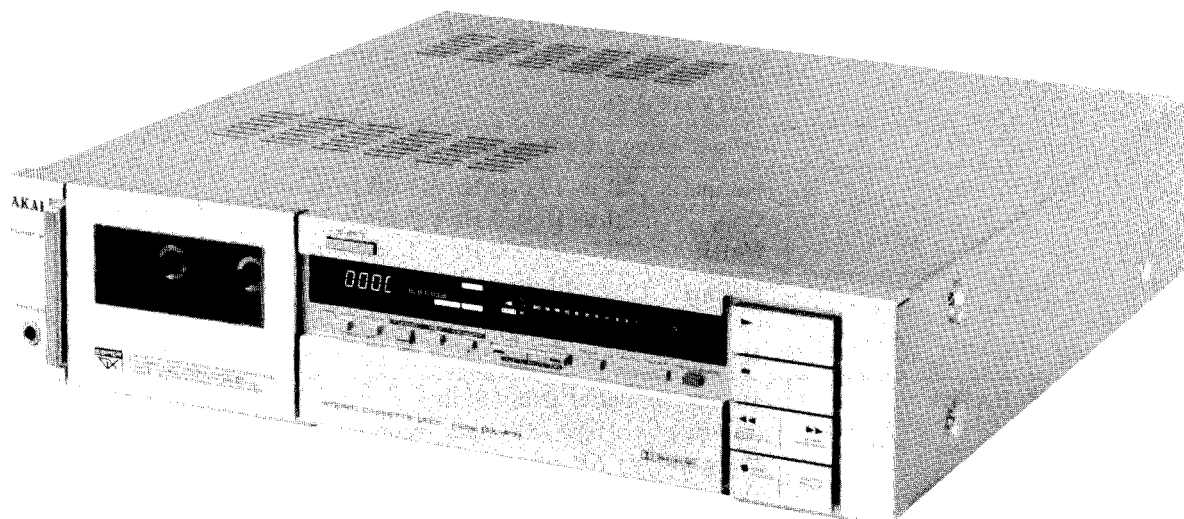

SECTION 4

SERVICE MANUAL

MODEL GX-F71

TABLE OF CONTENTS

I. SPECIFICATIONS	4- 2
II. DISMANTLING OF UNIT	4- 3
III. CONTROLS	4- 4
IV. PRINCIPAL PARTS LOCATION	4- 5
V. VOLTAGE CONVERSION	4- 6
VI. MECHANICAL ADJUSTMENT	4- 7
VII. HEAD ADJUSTMENT	4-10
VIII. AMPLIFIER ADJUSTMENT	4-12
IX. DC RESISTANCE OF HEADS	4-16
X. CLASSIFICATION OF VARIOUS P.C BOARDS	4-16
1. P.C BOARD TITLES AND IDENTIFICATION NUMBERS	4-16
2. COMPOSITION OF VARIOUS P.C BOARDS	4-17

For basic adjustments, measuring methods, and operating principles, refer to GENERAL TECHNICAL MANUAL.

I. SPECIFICATIONS

TRACK SYSTEM	4 Track 2 Channel Stereo System
TAPE	Philips Type Cassette
TAPE SPEED	4.76 cm/s \pm 1.0% (1-7/8 ips. \pm 1.0%)
HEADS	Super GX head for recording \times 1 Super GX head for playback \times 1 Erase head \times 1
MOTORS	FG servo D.C. motor for direct capstan drive \times 1 D.C. motor for reel drive \times 1
WOW & FLUTTER	0.08% WTD (DIN) 0.028% WRMS
TAPE WINDING TIME	90 sec. using a C-60 cassette tape
FREQUENCY RESPONSE	Normal: 20 to 17,000 Hz \pm 3 dB (-20 VU) CrO ₂ : 20 to 18,000 Hz \pm 3 dB (-20 VU) Metal: 20 to 21,000 Hz \pm 3 dB (-20 VU)
FREQUENCY RANGE	Normal: 15 to 18,000 Hz CrO ₂ : 15 to 20,000 Hz Metal: 15 to 21,000 Hz
SIGNAL TO NOISE RATIO	Metal: Better than 60 dB (measured via tape with peak recording level) Dolby B-type NR switch ON: Improves up to 5 dB at 1 kHz, 10 dB above 5 kHz Dolby C-type NR switch ON: Improves up to 15 dB at 500 Hz, 20 dB at 1 kHz to 10 kHz
HARMONIC DISTORTION	1 kHz, 3rd harmonic distortion Metal: Less than 0.8%
INPUT	Line: 70 mV (input impedance: 47 kohms)
OUTPUT	Line: 410 mV at 0 VU Required load impedance: more than 20 kohms Phone: 1.3 mW/8 ohms at 0 VU
DIN	Input: 2.0 mV (input impedance: 10 kohms) Output: 410 mV Required load impedance: more than 20 kohms
POWER REQUIREMENTS	100V, 50/60 Hz for Japan 120V, 60 Hz for USA and Canada 220V, 50 Hz for Europe except UK 240V, 50 Hz for UK and Australia 110V/120V/220V/240V, 50/60 Hz switchable for other countries.
POWER CONSUMPTION	U Model: 30W C, A, J Model: 28W
DIMENSIONS	440(W) \times 100(H) \times 377(D) mm (17.3 \times 3.9 \times 14.8")
WEIGHT	7.4 kg (16.3 lbs)

* For improvement purposes, specifications and design are subject to change without notice.

* "Dolby" and the Double D symbol are trademarks of Dolby Laboratories.

(Manufactured under license from Dolby Laboratories.)

II. DISMANTLING OF UNIT

GX-F71

In case of trouble, etc. necessitating dismantling, please dismantle in the order shown in the photographs. Reassemble in reverse order.

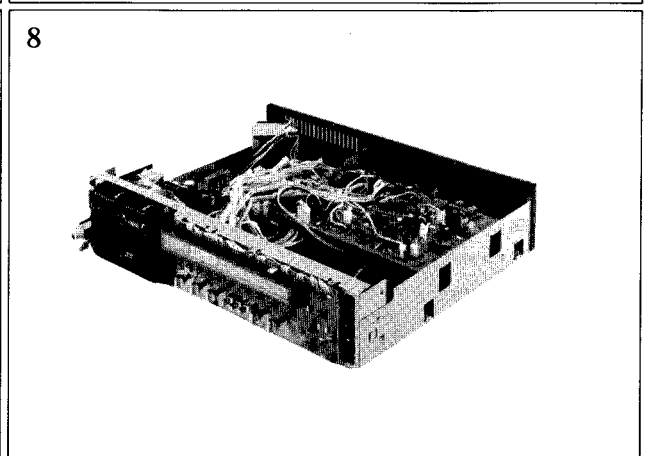
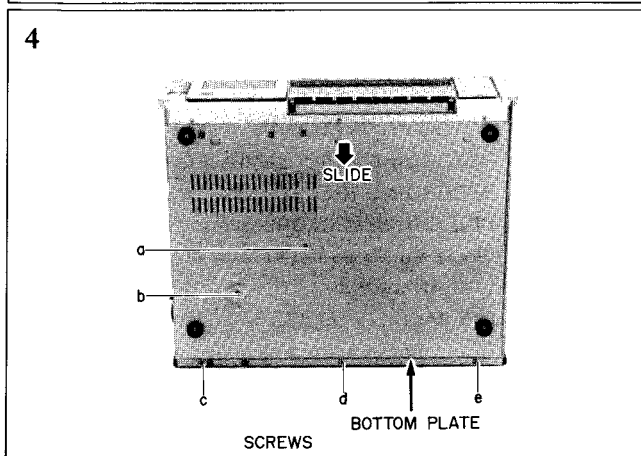
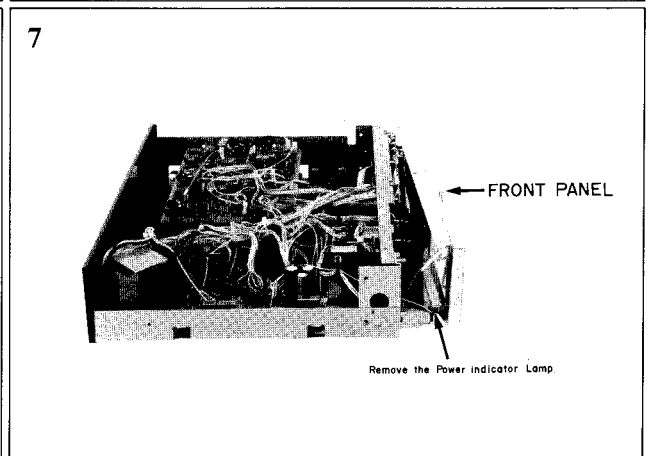
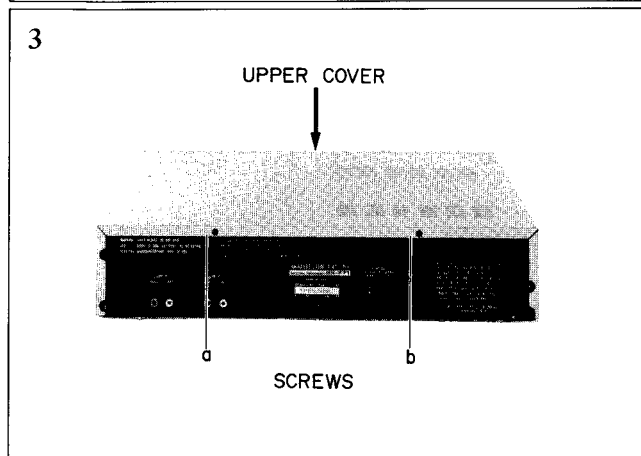
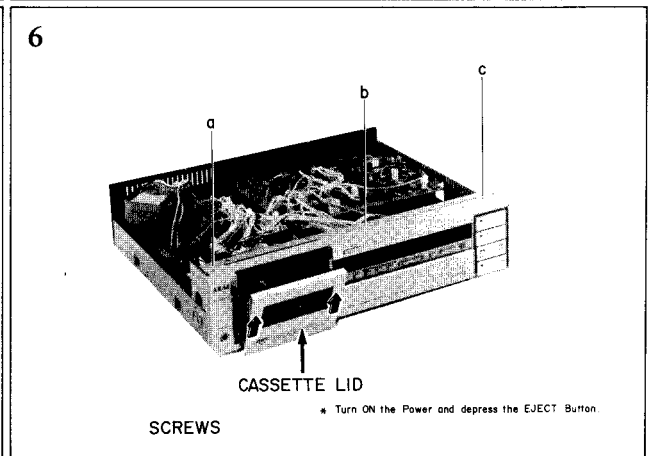
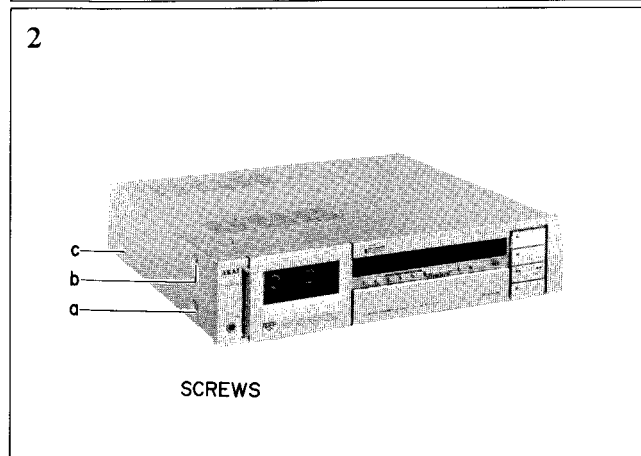
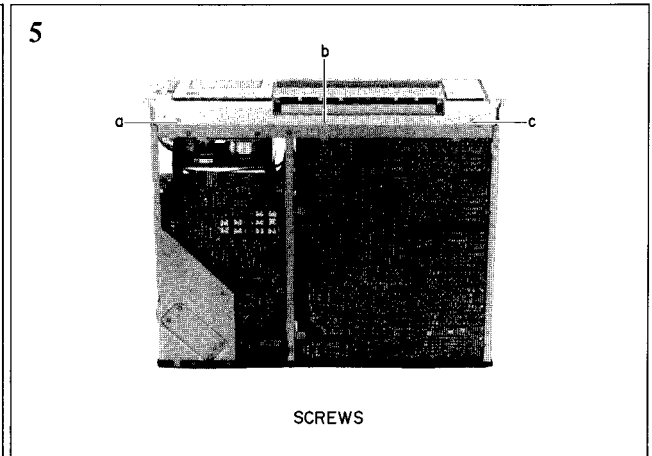
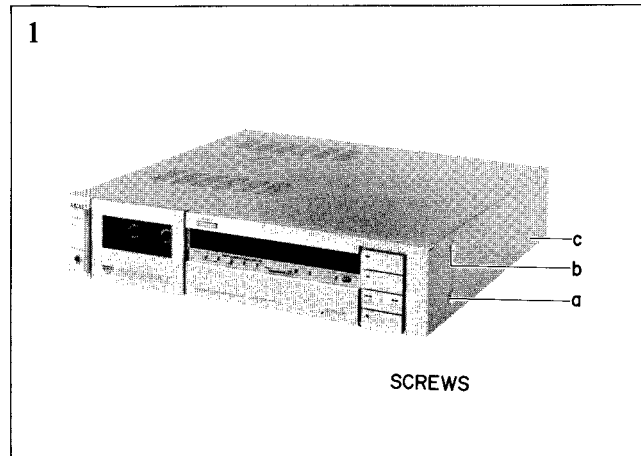

III. CONTROLS

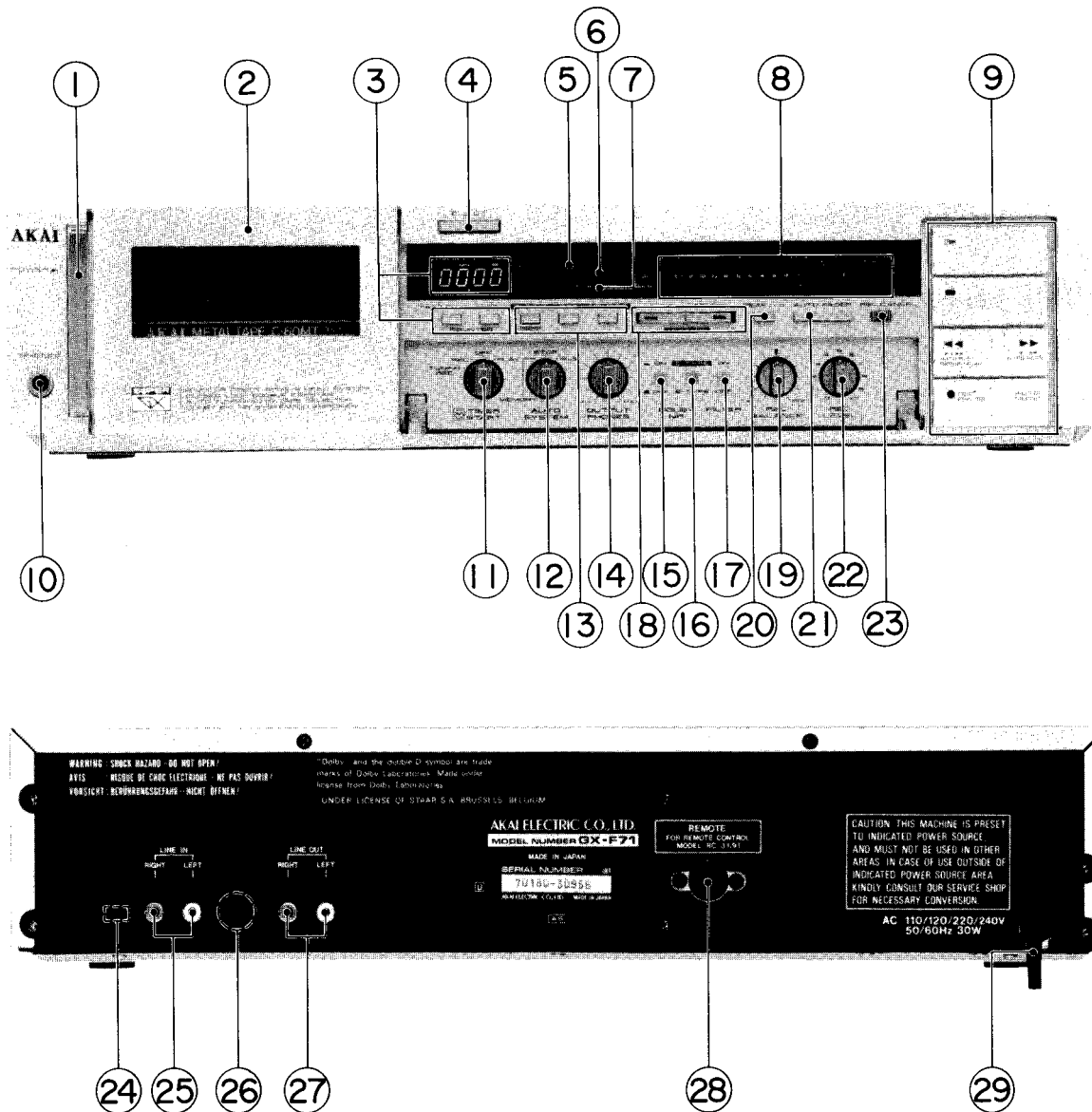

Fig. 1 Controls

- | | |
|---|---|
| <ol style="list-style-type: none"> 1. POWER SWITCH 2. CASSETTE RECEPTACLE 3. FLD TAPE COUNTER, TAPE/TIME SELECTOR and RESET BUTTON 4. EJECT BUTTON 5. TAPE POSITION INDICATORS 6. AUTO TAPE TUNING INDICATORS 7. DOLBY B and DOLBY C and FILTER INDICATORS 8. FLD BAR METER with MAXIMUM INPUT LEVEL INDICATORS 9. OPERATING BUTTONS
PLAY (▶) BUTTON with INDICATOR
STOP (■) BUTTON
REWIND (◀) BUTTON
FAST FORWARD (▶▶) BUTTON
RECORDING (REC)/PAUSE BUTTON with INDICATOR
AUTO MUTE BUTTON 10. HEADPHONE (PHONES) JACK 11. TIMER START SELECTOR 12. AUTO SYSTEM SELECTOR | <ol style="list-style-type: none"> 13. TUNING and REFERENCE (REF) BUTTONS 14. OUTPUT/HEADPHONE (PHONES) CONTROL 15. DOLBY NR SWITCH 16. DOLBY NR SELECTOR 17. MPX FILTER SWITCH 18. MONITOR SELECTOR 19. RECORDING (REC) BALANCE CONTROL (LEFT and RIGHT) 20. PEAK/VU SELECTOR 21. AUTO FADER BUTTON 22. RECORDING (REC) LEVEL CONTROL 23. RECORDING (REC) CANCEL BUTTON 24. LINE/DIN SELECTOR
(Some models do not have this facility) 25. LINE IN JACKS 26. DIN JACK
(Some models are not equipped with this facility.) 27. LINE OUT JACKS 28. REMOTE JACK 29. POWER CORD |
|---|---|

IV. PRINCIPAL PARTS LOCATION

GX-F71

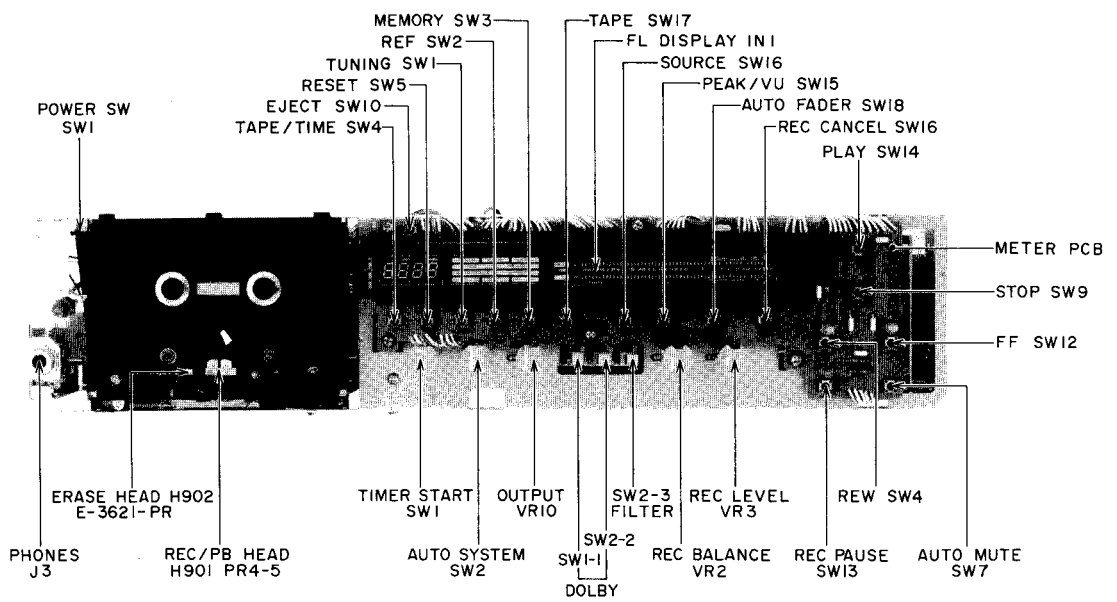

Fig. 2 Front View

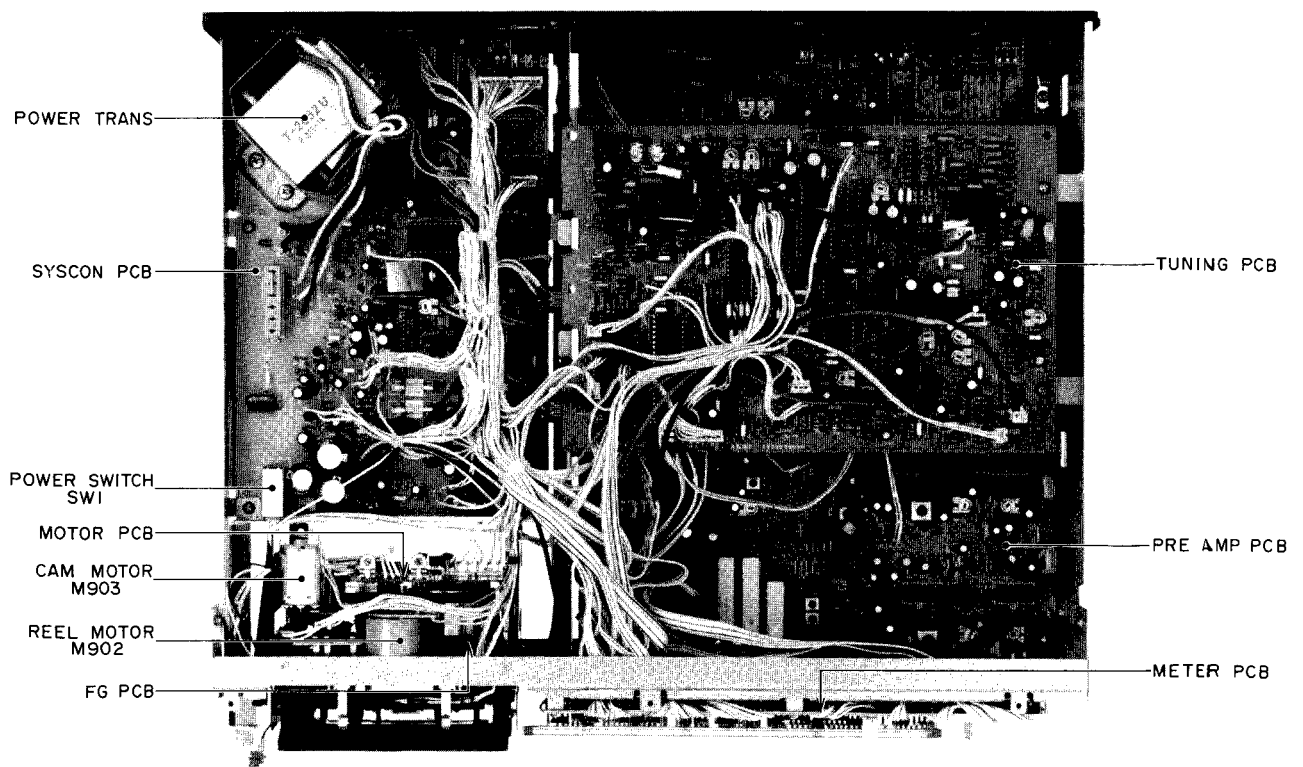

Fig. 3 Top View

V. VOLTAGE CONVERSION

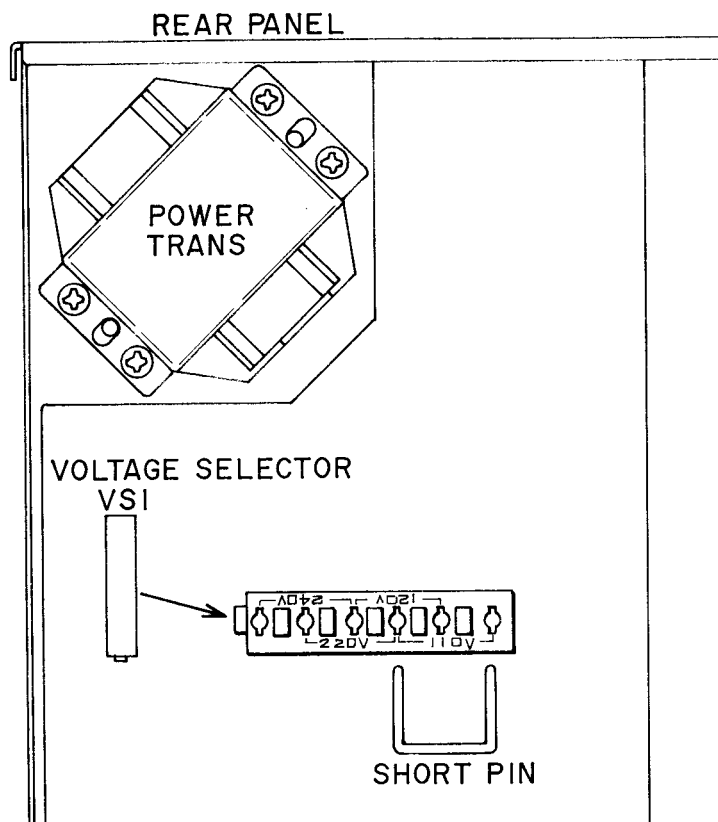

Fig. 4 Voltage Conversion (U Model)

1. VOLTAGE CONVERSION

Models for Canada, Europe, USA, UK, Australia and Japan are not equipped with this facility.

Each machine is preset at the factory according to destination, but some machines can be set to 110V, 120V, 220V or 240V as required.

If voltage change is necessary, this can be accomplished as follows:

- 1) Disconnect power cord.
- 2) Loosen holding screws and remove upper cover.
- 3) Remove short pin plug from present holes and replace in correct holes. Follow the markings explicitly.

2. CYCLE CONVERSION

With DC motor, cycle conversion is not necessary.

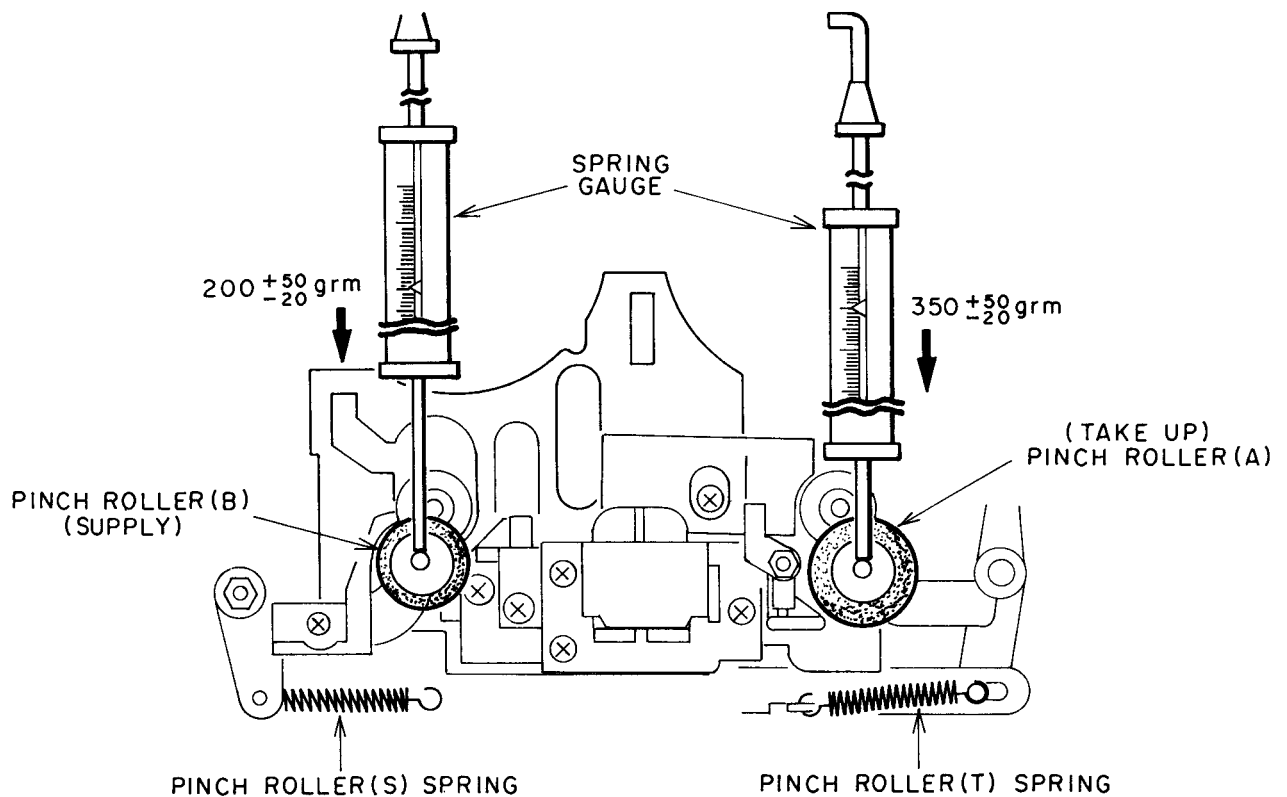

Fig. 5

1. PINCH ROLLER PRESSURE

MEASUREMENT (Refer to Fig. 5)

Put in PLAY mode. Push pinch roller arm down with the spring gauge push the pinch roller 1 ~ 2 mm from the capstan and release slowly. Read the spring gauge at the moment the pinch roller touches the capstan and begins to rotate.

Specified pressure: $350 \begin{smallmatrix} +50 \\ -20 \end{smallmatrix}$ gm (Take up)

$200 \begin{smallmatrix} +50 \\ -20 \end{smallmatrix}$ gm (Supply)

If there is no measurement obtained, replace the pinch roller spring.

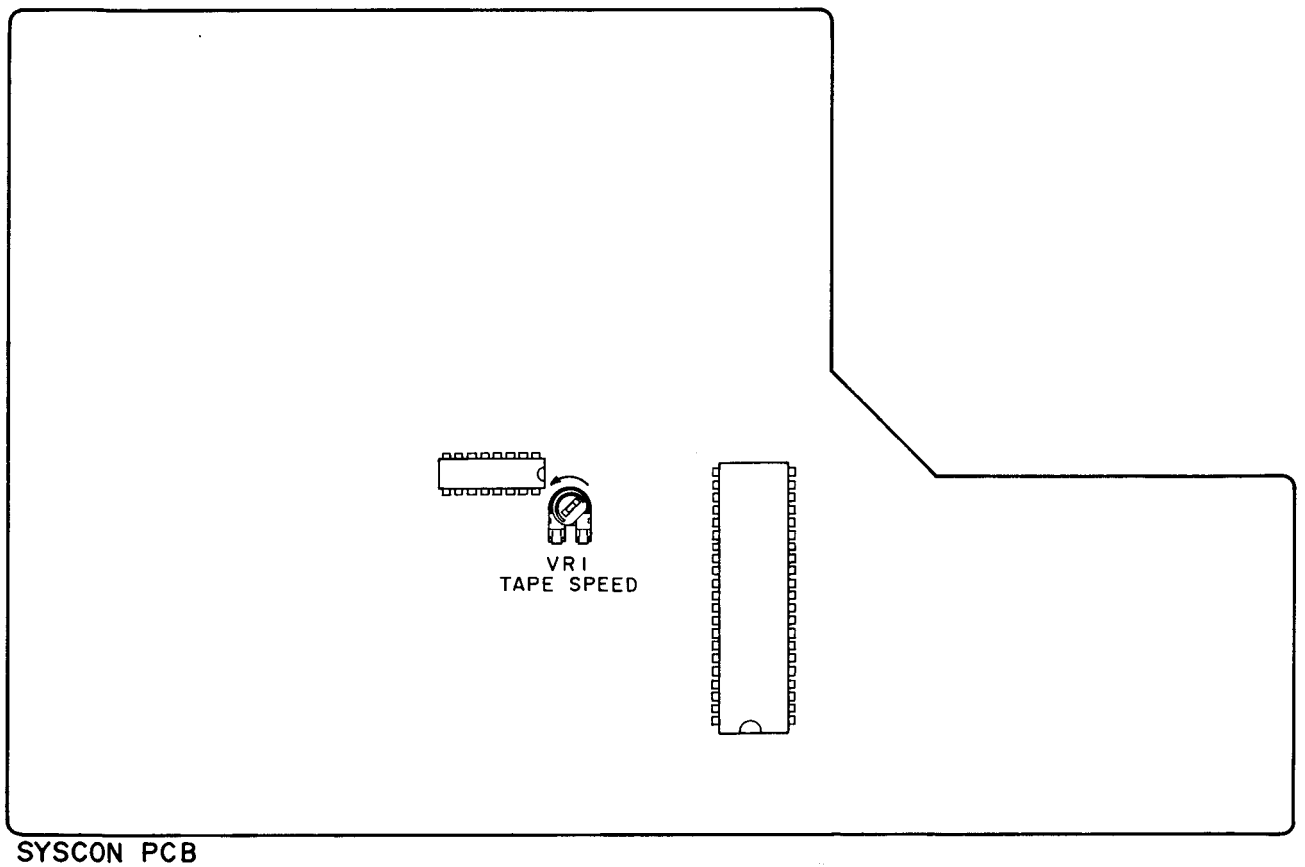

Fig. 6

2. TAPE SPEED ADJUSTMENT

Connect a frequency counter to line output terminals. Playback a 1,000 Hz pre-recorded test (TF-102CS) tape and adjust tape speed adjustment volume (SYSCON PCB VR1) to obtain a tape speed of 995 Hz to 1000 Hz.

3. HOW TO INSTALL VOLUME (VR901) AND CAM WHEEL

Refer to Section 2-V-3 (GX-F31).

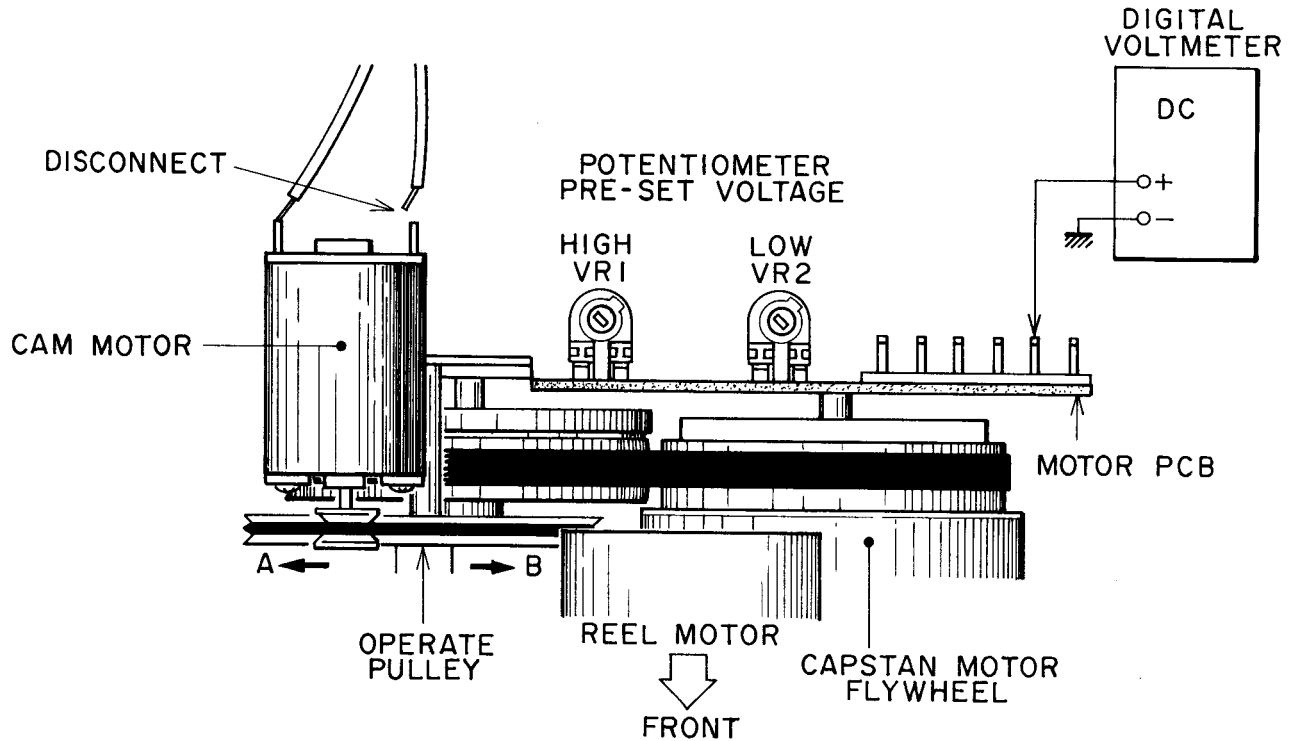

Fig. 7-1

4. POTENTIOMETER PRESET VOLTAGE ADJUSTMENT (Refer to Fig. 4)

1) LOW VOLTAGE ADJUSTMENT

- With power OFF, remove the connecting cord of the cam motor and turn the operate pulley fully with your fingers in A direction.
- Connect the digital voltmeter as shown in Fig. 7-1.
- With power ON, adjust VR2 so that the voltage reading will be 0.78V (DC).

2) HIGH VOLTAGE ADJUSTMENT

- With power OFF, turn the operate pulley fully with your fingers in B direction.
- With power ON, adjust VR1 so that the voltage reading will be 6.73V (DC).

3) Repeat Items 1) and 2).

- With Power OFF, connect the connecting cord of the motor.
 - Remove the digital voltmeter.

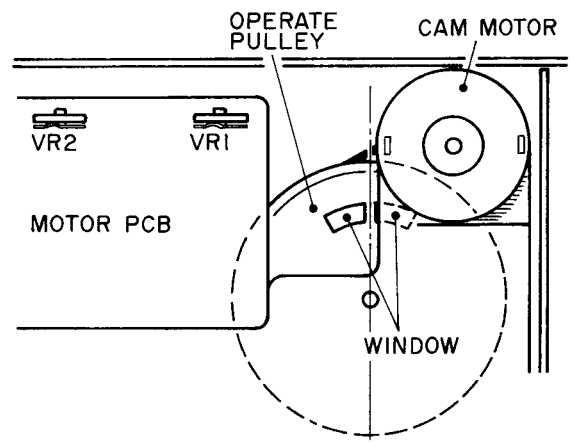

Fig. 7-2 Position of Operate Pulley in STOP Mode

- Set power to ON.
 - Adjust VR1 slightly so that a center line between windows of the operate pulley will face directly above during STOP Mode. (Fig. 7-2)
 - Remove the cassette lid and set the AUTO SYSTEM switch to IPLS Mode.
 - Confirm that the head and pinch roller do not move up and down when the FF and REW switches are alternately depressed.
 - Turn the reel with fingers in STOP Mode to check that the brake works sufficiently. When the brake acts normally, the take-up reel does not turn clockwise while the supply reel does not rotate counterclockwise.

VII. HEAD ADJUSTMENT

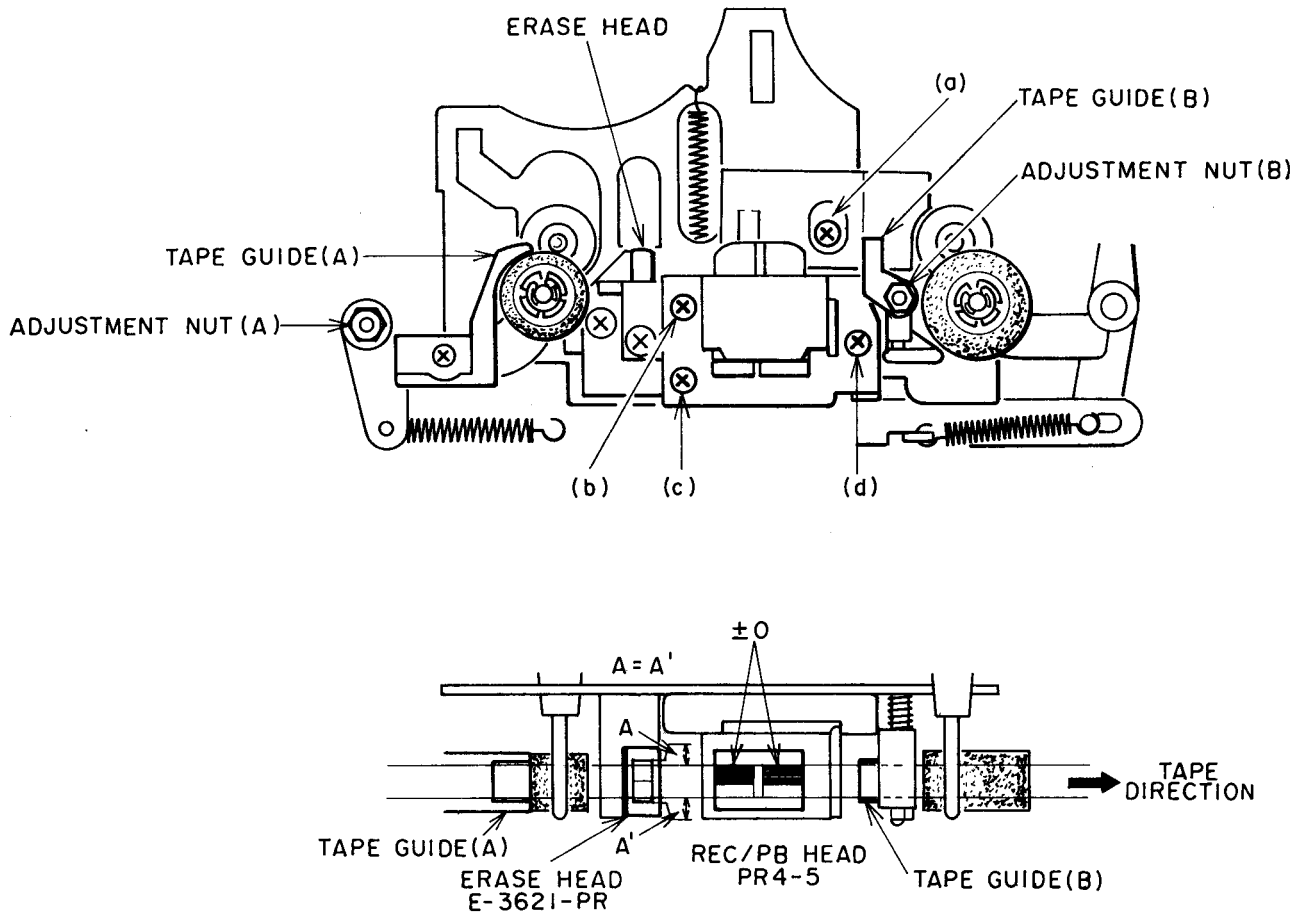

Fig. 8

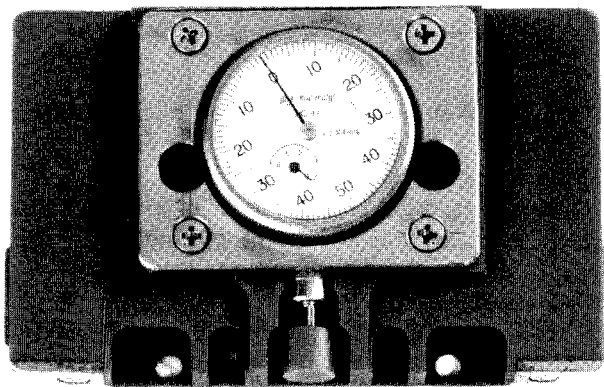

Fig. 9 Cassette Head Projection Gauge (TF-111CJ)



Fig. 10 Mirror Cassette Tape (TF-109CM)

1. REC/PB HEAD PROJECTION ADJUSTMENT

Set the cassette head projection gauge (TF-111CJ) and set to PLAY mode. Loosen the screw (a) and adjust so that the gauge indication at that time will be 3.2 ± 0.05 mm. After adjustment, apply paintlock on the screw (a).

2. TAPE GUIDE HEIGHT ADJUSTMENT

- 1) Set the mirror cassette tape (TF-109CM) and set to PLAY mode.
2. Adjust the tape guide (A) so that the parts of the erase head coming out of both sides of the tape (A and A' in Fig. 8) will be equal. For the adjustment, use the adjustment nut (A).
- 3) Adjust the tape guide (B) so that the tape runs smoothly and is not hitched by the tape guide. For the adjustment, use the adjustment nut (B).
- 4) After adjustment, paint-lock the adjustment nuts (A) and (B).

3. REC/PB HEAD HEIGHT ADJUSTMENT

- 1) Set the mirror cassette tape and set to PLAY mode.
- 2) Adjust the screws (b), (c) and (d) so that the upper edge of REC/PB head Lch core and the upper side of the tape is in alignment.
- 3) Playback the head height adjustment tape (4Tr 1,000 Hz) (TF-103CF), and fine-adjust the screws (b), (c) and (d) so that the largest output is obtained for both channels.

4. REC/PB HEAD AZIMUTH ALIGNMENT ADJUSTMENT

- 1) Playback a 10 kHz Head Azimuth Alignment Tape (TF-106CH) and adjust the screw (d) until the output levels of both channels are at maximum.
- 2) Record a 10 kHz, -20VU signal from the audio frequency oscillator.
- 3) Rewind and check for any fluctuation in the output level at playback.
- 4) After adjustment, paintlock the screws (b), (c) and (d).

NOTES:

1. Be sure to clean the heads prior to head adjustment.
2. Be careful not to use a magnetized driver or other magnetized tools in the vicinity of the heads.
3. Be sure to demagnetize the heads with a Head Demagnetizer before and after head adjustment.

VIII. AMPLIFIER ADJUSTMENT

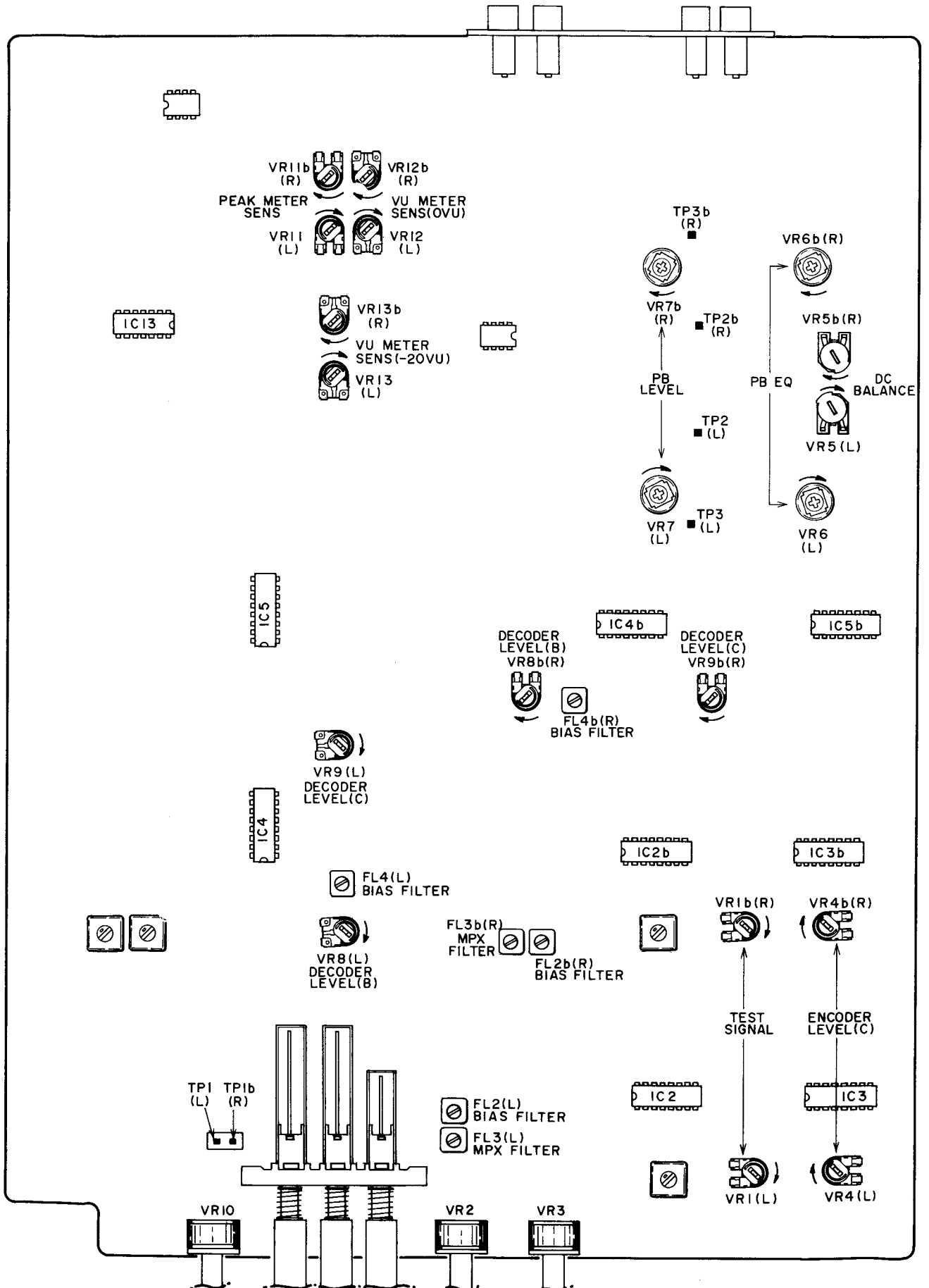

Fig. 11 Pre Amp P.C Board

1. PB EQ AMP ADJUSTMENT (Fig. 11)

- 1) DC Balance
Adjust VR5 so that the voltage of TP2 will be $0 \pm 0.2V$ DC.
- 2) PB Level
Play back 333 Hz PB level adjustment tape (TF-101CL) and adjust VR7 so that the LINE OUT level will be -5.5 ± 0.2 dBm.
- 3) PB EQ
Play back 10 kHz PB EQ adjustment tape (TF-106CH) and adjust VR6 so that the LINE OUT level will -22.5 ± 1.5 dBm.

2. METER ADJUSTMENT (Fig. 11)

- 1) VU Meter
 - a. With the monitor SW to SOURCE and the meter SW to VU, input a signal of 1 kHz through LINE IN.
 - b. Adjust VR12 so that the +1VU goes out when the LINE OUT level is set to -5.2 dBm.
 - c. Adjust VR13 so that the $-20VU$ goes out when the LINE OUT level is set to -27.6 dBm.
 - d. Repeat b.
- 2) Peak Meter
 - a. With the meter SW to PEAK, input a signal of 1 kHz from the LINE IN.
 - b. Adjust VR11 so that the +9 dB goes out when the LINE OUT level is set to $+2.8$ dBm.

3. DOLBY ENCODER ADJUSTMENT (Fig. 11)

- 1) Dolby C-type level adjustment
 - a. With the monitor SW to SOURCE, input signal of 400 Hz into the LINE INPUT and adjust the input level so that the level of TP1 will be -2.5 ± 0.1 dBm (580 mV) when Dolby is OFF.
 - b. Adjust VR4 so that the level of TP1 will be the same level as a. (-2.5 ± 0.1 dBm) when Dolby C-type is ON.
- 2) MPX Filter Adjustment
 - a. With the monitor SW to SOURCE and MPX filter SW "OFF", input a signal of 19 kHz from LINE IN.
 - b. Adjust FL3 so that the LINE OUT level will be at minimum when MPX filter SW is turned ON.
- 3) BIAS Filter Adjustment
 - a. Set a meter tape and set to REC/PLAY (or REC/PLAY \rightarrow REC/PAUSE).
 - b. Adjust FL2 so that the LINE OUT level will be at minimum when the input volume is set to MAX and the monitor SW to SOURCE.
 - c. Check in other positions.

4. DOLBY DECODER ADJUSTMENT (Fig. 11)

- 1) Dolby B-type level adjustment
 - a. Set to PLAY mode without inserting a tape.
 - b. Input the signal of 400 Hz into TP3 and adjust the input level so that the LINE OUT level will be -2.5 ± 0.1 dBm (580 mV) when Dolby: OFF.
 - c. Adjust VR8 so that the LINE OUT level will be the same level as b. (-2.5 ± 0.1 dBm), when Dolby B-type: ON.
- 2) Dolby C-type level adjustment
 - a. Carry out 1)-a, b adjustment.
 - b. Adjust VR9 so that the LINE OUT level will be the same level as a. (-2.5 ± 0.1 dBm) when Dolby C-type: ON.
- 3) Bias Filter Adjustment
 - a. Set a metal tape and set to REC/PLAY mode.
 - b. Adjust FL4 so that the LINE OUT level will be at minimum when the monitor SW is set to TAPE.
 - c. Check in other positions.

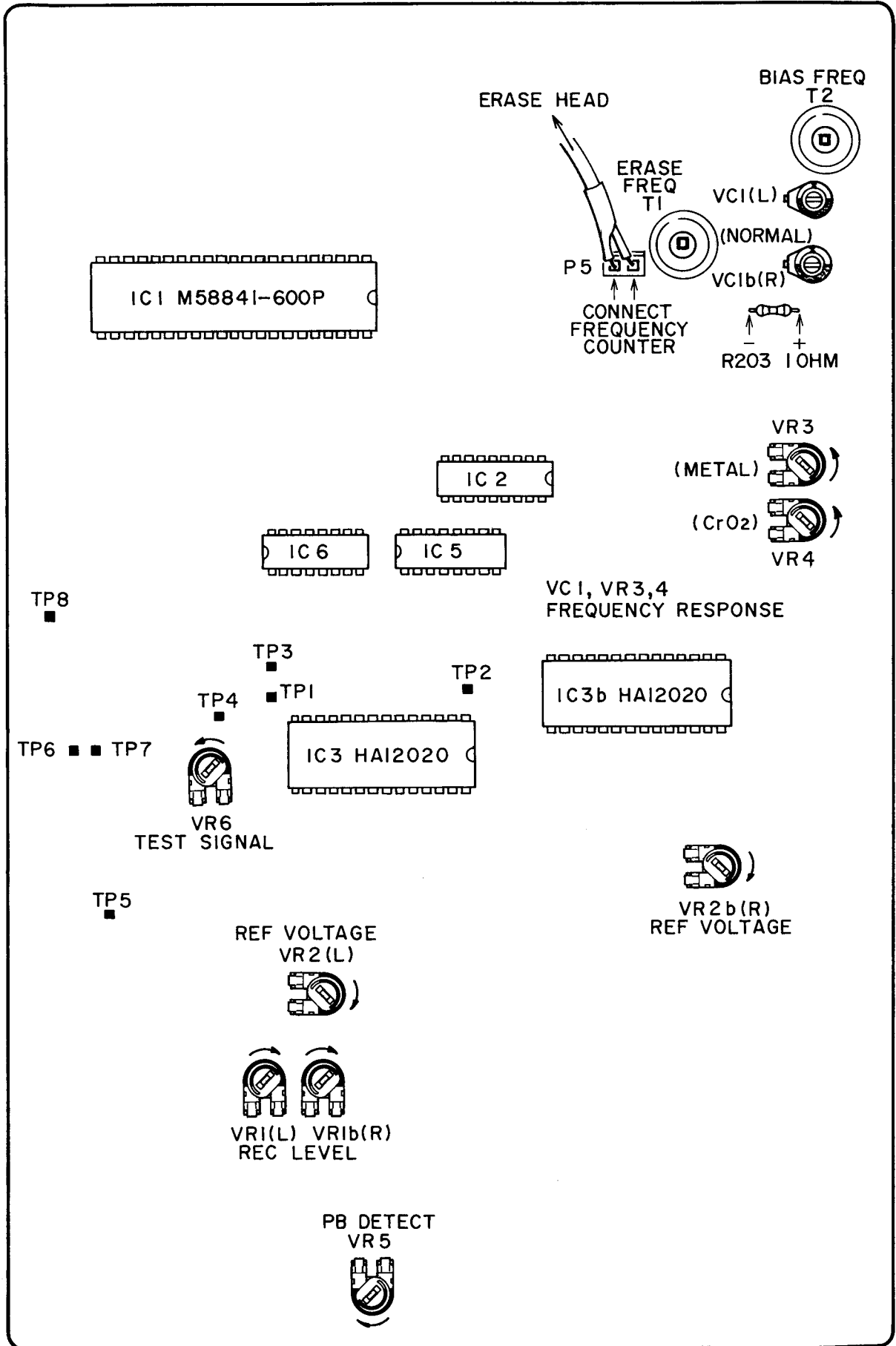

Fig. 12 Tuning P.C Board

5. IC3 (HA12020) REFERENCE VOLTAGE**ADJUSTMENT (Fig. 12)**

- a. Set the mode to REF. (with power ON, REF is achieved)
- b. Adjust VR2 (L) so that the voltage to GND of TP1 will be $1.10 \pm 0.03V$ DC.
- c. Adjust VR2b (R) so that the voltage to GND of TP2 will be $4.00 \pm 0.05V$ DC (before SERIAL NUMBER 70401-00101), $5.10 \pm 0.05V$ DC (after SERIAL NUMBER 70401-00101).

6. REC BIAS OSC ADJUSTMENT (Fig. 12)

- a. Set a metal tape and set to REC/PLAY mode.
- b. Set VC1 as shown in Fig. 12.
- c. Connect the frequency counter to P5 (tuning PCB) and adjust T1 so that the frequency will be 100 ± 0.2 kHz.
- d. Connect a DC voltmeter to both ends of R203 (1 ohm) and adjust T2 so that the voltage will be at minimum.

7. FREQUENCY RESPONSE**ADJUSTMENT (Fig. 12)**

- a. Record and play back 1 kHz/10 kHz, -25.5 dBm using a normal tape and adjust VC1 so that 1 kHz/10 kHz will be 0 ± 0.5 dBm (provided L-R difference is within 0.5 dBm).
- b. Record and play back 1 kHz/10 kHz, -25.5 dBm using a CrO₂ tape and adjust VR4 so that 1 kHz/10 kHz will be 0 ± 0.5 dBm.
- c. Record and play back 1 kHz/10 kHz, -25.5 dBm using a metal tape and adjust VR3 so that 1 kHz/10 kHz will be 0 ± 0.5 dBm.

8. RECORDING LEVEL ADJUSTMENT**(Fig. 12)**

Record and play back 1 kHz, -5.5 dBm using a normal tape, and adjust VR1 so that the difference between recording and play back levels will be 0 ± 0.3 dBm.

9. TEST SIGNAL ADJUSTMENT (Fig. 12)

- a. In REF mode, with recording volume to MIN. (or input: OFF), connect TP5 and TP8 to GND.
- b. Connecting an AC voltmeter (mV meter) to TP4, adjust VR6 so that the AC voltmeter difference when TP6 and TP7 are connected to GND and when they are not connected, will be within 0.5 dBm.

Reference:

When both TP6 and TP7 are open

TEST SIGNAL: 1 kHz

When TP6 = open, TP7 = GND

TEST SIGNAL: 7 kHz

When both TP6 and TP7 are to GND

TEST SIGNAL: 13 kHz

- c. With the monitor SW to SOURCE, adjust VR1 (Fig. 11 Pre Amp PCB) so that the LINE OUT level will be -25.5 ± 0.2 dBm.

10. LEVEL ADJUSTMENT OF PLAYBACK OUTPUT LEVEL DETECTION CIRCUIT

Adjust VR5 so that the voltage to GND of TP3 will be $4.0 \pm 0.1V$ DC (before SERIAL NUMBER 70401-00101), $5.1 \pm 0.1V$ DC (after SERIAL NUMBER 70401-00101) under 9-C conditions.

NOTES:

1. Using a digital voltmeter for the measurement of DC voltage and an AC voltmeter (mV meter) for AC voltage measurement, the input impedance should be 10M ohm or more.
2. Output level control should be at maximum.
3. Use the following cassette measuring tapes:

Normal tape	: Maxell UD C-60
CrO ₂ tape	: TDK SA C-60
Metal tape	: TDK MA C-60

IX. DC RESISTANCE OF HEADS

Description	Name	DC Resistance
REC/PB Head	PR4-5	PB: 340 ohms \pm 10% REC: 320 ohms \pm 10%
Erase Head	E-3621-PR	2.5 ohms \pm 15%

X. CLASSIFICATION OF VARIOUS P.C BOARDS

1. P.C BOARD TITLES AND IDENTIFICATION NUMBERS

P.C Board Title	P.C Board Number
Pre Amp P.C Board	T2032A501A
Phone Jack P.C Board	T2032A501B
Tuning P.C Board	T2032B5030
Syscon P.C Board	T2032B502A
Switch P.C Board	T2032B502B
TR P.C Board (A)	T2032B502C
TR P.C Board (B)	T2032B502D
Meter P.C Board	T2032B5040
Motor P.C Board	M3103C726A
Potention P.C Board	M3103C726B
FG P.C Board	M3103C7130
Filter P.C Board	T2029D5040
Detector P.C Board	T2029D5030
Micro SW P.C Board	T2029D5020

B, S MODEL

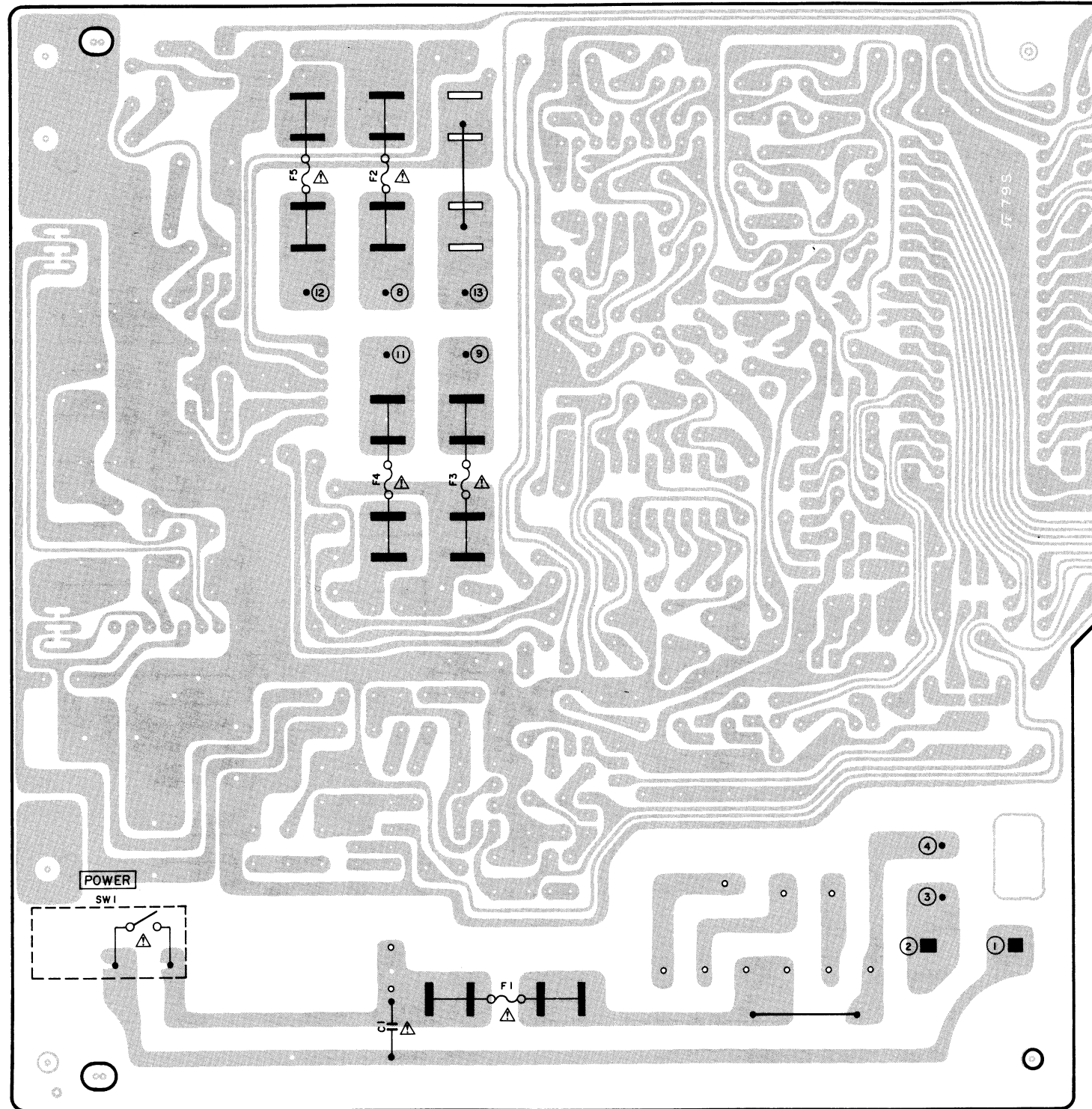

J, C, A, E, V MODEL

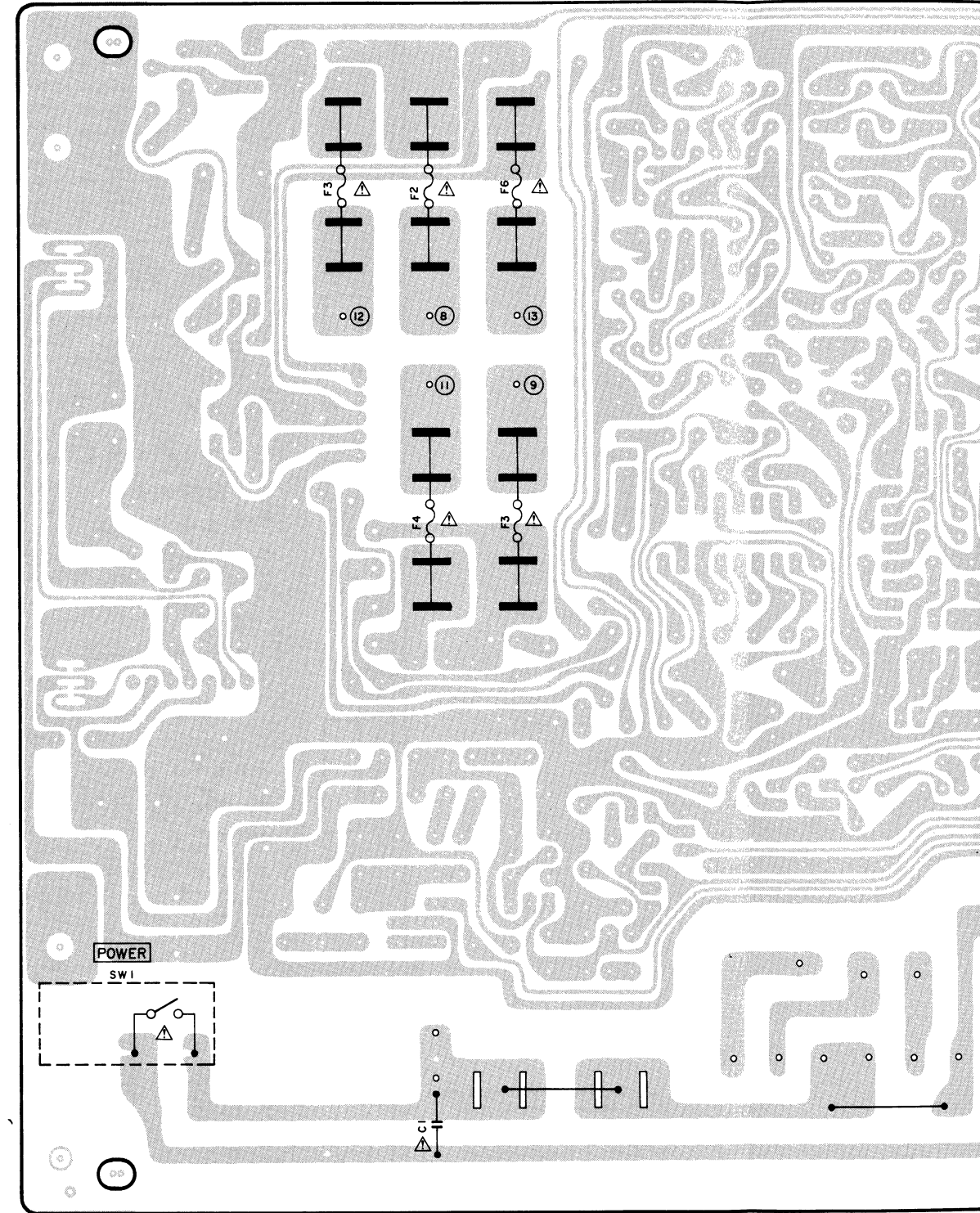

WARNING: Δ INDICATES SAFETY CRITICAL
REPLACE SAFETY CRITICAL
RECOMMENDED PARTS
AVERTISSEMENT: Δ IL INDIQUE LES COM-
MAINTENIR LE DEGRÉ DE SE-
COMPOSANTS DONT LE FONC-
QUE PAR DES PIÈCES RECOM-

B, S MODEL

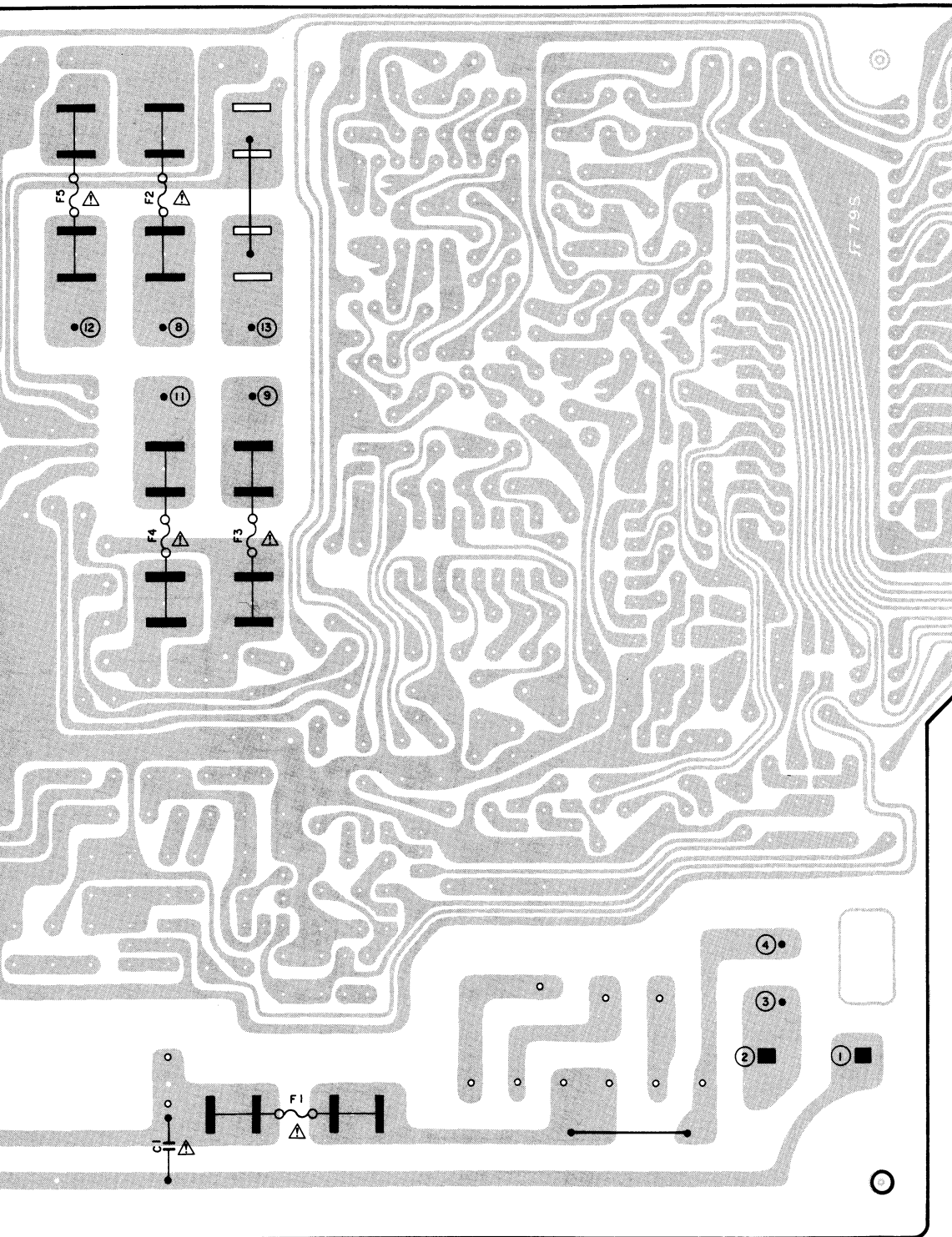

J, C, A, E, V MODEL

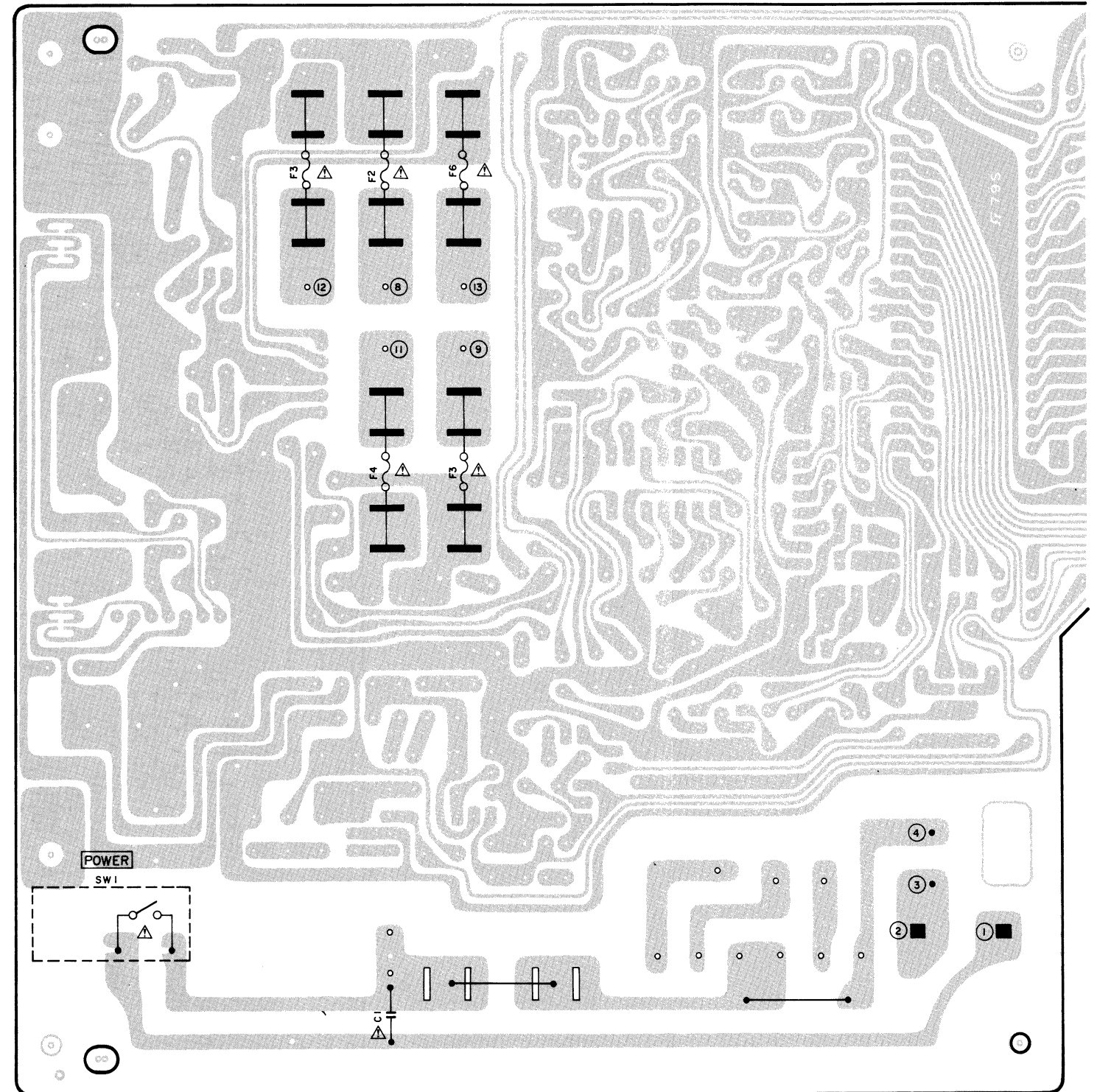

WARNING: Δ INDICATES SAFETY CRITICAL COMPONENTS. FOR CONTINUED SAFETY, REPLACE SAFETY CRITICAL COMPONENTS ONLY WITH MANUFACTURER'S RECOMMENDED PARTS.
 AVERTISSEMENT: Δ IL INDIQU LES COMPOSANTS CRITIQUES DE SÛRETÉ. POUR MAINTENIR LE DEGRÉ DE SÛRETÉ DE L'APPAREIL NE REMPLACER LES COMPOSANTS DONT LE FONCTIONNEMENT EST CRITIQUE POUR LA SÛRETÉ QUE PAR DES PIÈCES RECOMMANDÉES PAR LE FABRICANT.

3) TUNING P.C BOARD T2032B5030 (2ED)

LOCATION OF COMPONENTS

IC

- IC1 ----- A1
- IC2 ----- B2
- IC3 ----- C2
- IC3b ----- C3
- IC4 ----- E2
- IC5, 6 ----- B2

TR

- TR1, 2 ----- A2
- TR3 ----- E3
- TR3b ----- E2
- TR4 to 7 ----- D1
- TR8 ----- E1
- TR9, 10 ----- A2
- TR11 to 14, 12b to 14b ----- D3
- TR15, 16 ----- A1
- TR17 to 21 ----- B3
- TR22 ----- E2
- TR23, 24 ----- E1
- TR25 ----- B3
- TR26, 27 ----- A3
- TR28, 29 ----- B3
- TR30 to 33 ----- A3
- TR34 ----- B1
- TR35, 36 ----- A1
- TR37, 38 ----- C1
- TR39 ----- D1
- TR40 ----- B1
- TR41 ----- C1
- TR42, 43 ----- B2
- TR44 to 46 ----- A2
- TR47, 47b, 48, 48b ----- D2
- TR49 ----- A2

TERMINAL

- P1, 2 ----- A2
- P3 ----- E1
- P4 ----- B3
- P5 ----- A3
- P6 ----- E1
- P7, 8 ----- A1
- P9 ----- E2
- P10 ----- A1
- P11 ----- C1
- P12 ----- D3
- P13 ----- B1
- P14 ----- B3

- TR1, 2, 4 to 10, 12 to 18, 20 to 26, 28, 29, 34 to 41, 46 to 49 --- 2SC2603(F, G)
- TR 3 ----- 2SD1012(V, G)
- TR11 ----- 2SC1061(B, C)
- TR19, 27 ----- 2SD612(K, E, F)
- TR30 to 33 ----- 2SC2274(K, F)
- TR42 to 45 ----- 2SA1115(E, F)

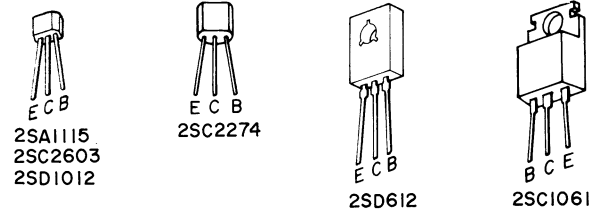
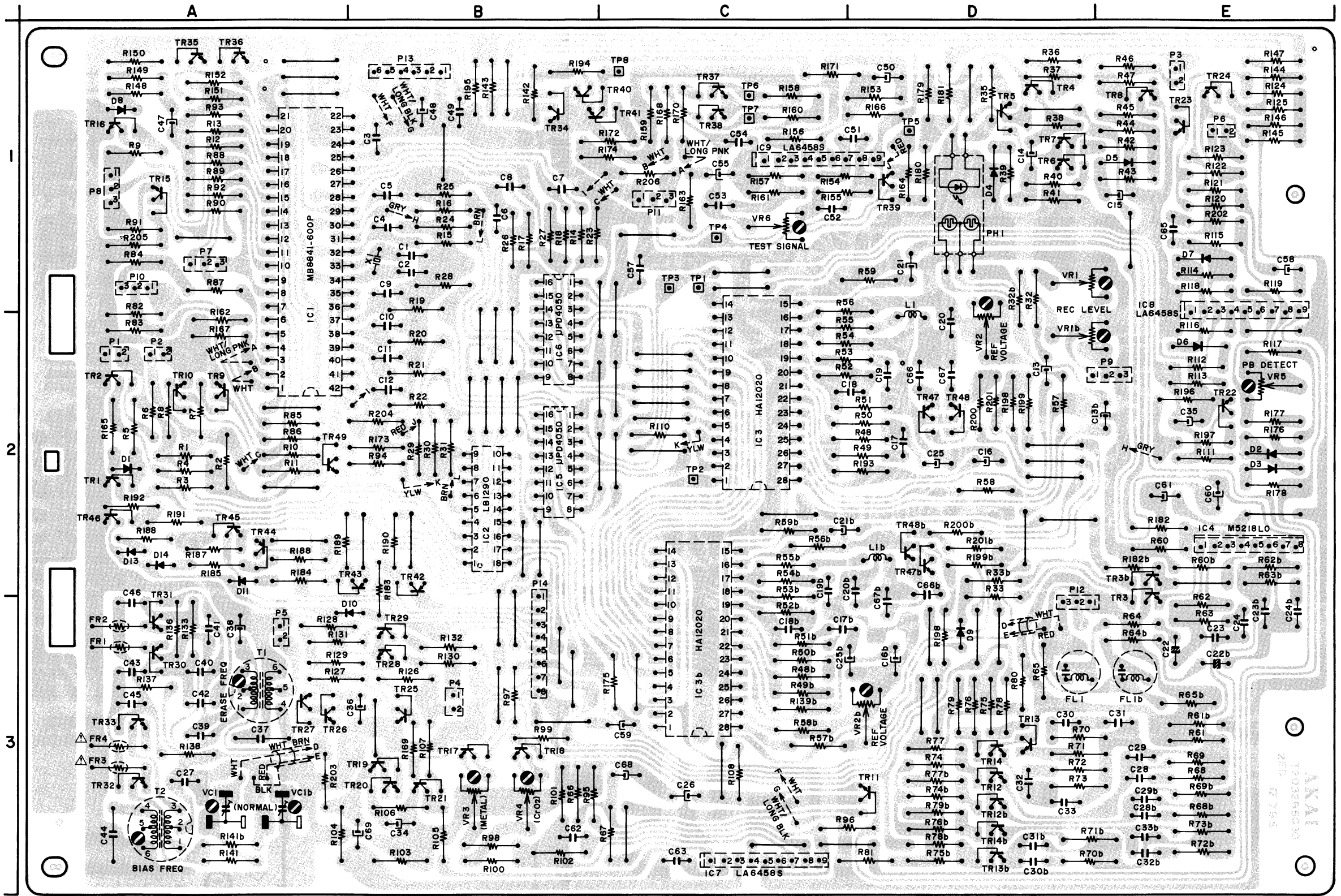

WARNING: Δ INDICATES SAFETY CRITICAL COMPONENTS. FOR CONTINUED SAFETY, REPLACE SAFETY CRITICAL COMPONENTS ONLY WITH MANUFACTURER'S RECOMMENDED PARTS.
 AVERTISSEMENT: Δ IL INDIQUÉ LES COMPOSANTS CRITIQUES DE SÛRETÉ. POUR MAINTENIR LE DEGRÉ DE SÛRETÉ DE L'APPAREIL, NE REMPLACER LES COMPOSANTS DONT LE FONCTIONNEMENT EST CRITIQUE POUR LA SÛRETÉ QUE PAR DES PIÈCES RECOMMANDÉES PAR LE FABRICANT.

2. COMPOSITION OF VARIOUS P.C BOARDS

1) PRE AMP P.C BOARD T2032A501(2ED) and PHONE JACK P.C BOARD T2032A501B

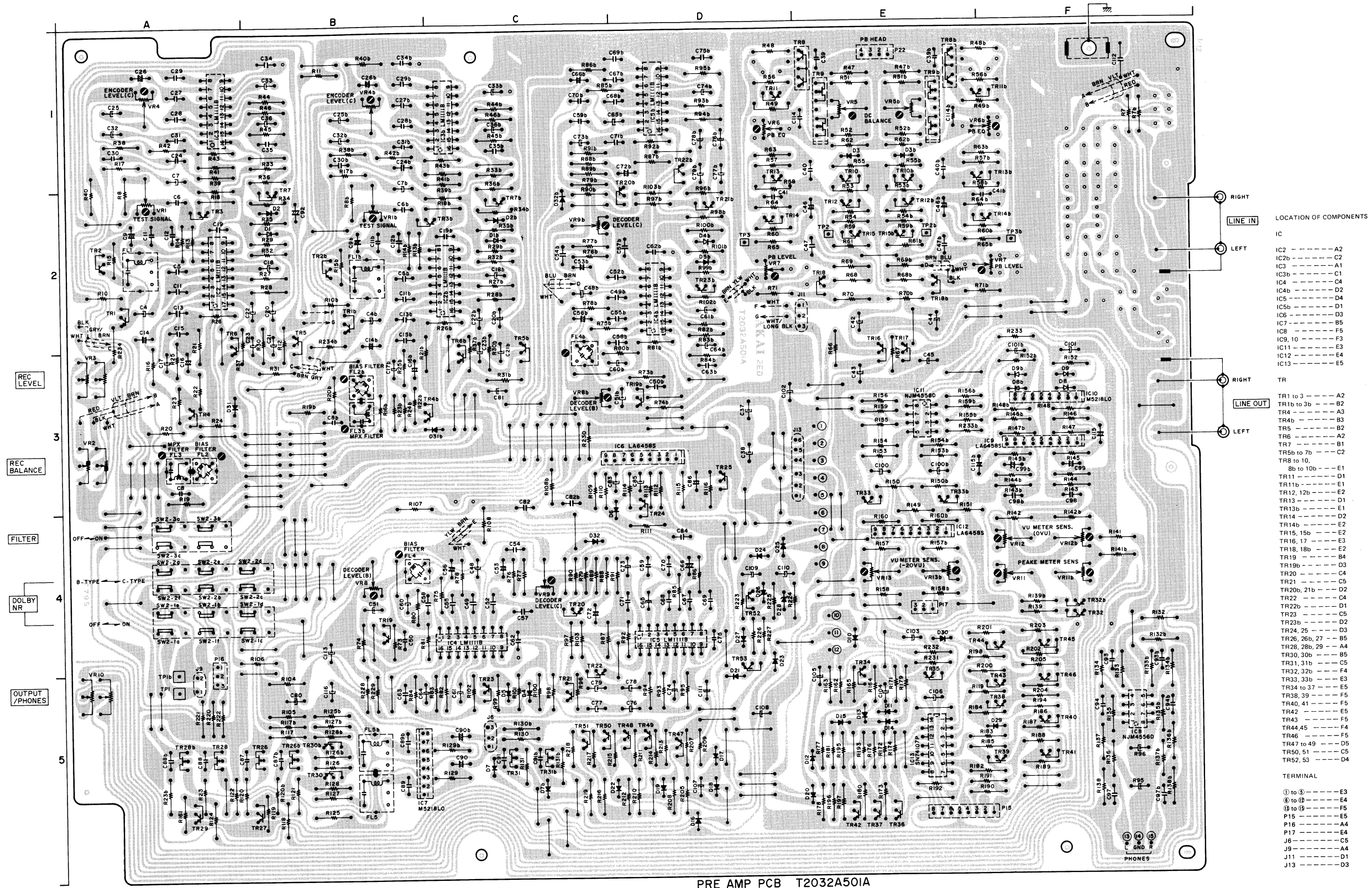

PRE AMP PCB T2032A501A

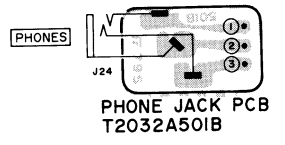

PHONE JACK PCB T2032A501B

- TR1 to 7, 19 to 25, 27, 29, 30, 32
34 to 39, 42 to 44, 47 to 50, 52
--- 2SC2603(E,F)
- TR8 --- 2SA995(E,F)
- TR9 --- 2SK270(GR, BL)
- TR10, 12 --- 2SC1843(E,F)
- TR11 --- 2SA990(E,F)
- TR13, 14, 16 --- 2SC2320(E,F)
- TR15 --- 2SA991(E,F)
- TR16 --- 2SD1012-V(F,G)
- TR17 --- 2SB808-V(F,G)
- TR26, 28 --- 2SK170(BL,V)
- TR31 --- 2SK117(GR, BL)
- TR33, 40, 41, 45
46, 51, 53 --- 2SA1115(E,F)

- ECB
- ECB
- DGS
- ECBCE
- D1 G1 S1 S2 G2 D2
- 2SA990
- 2SA1115
- 2SA999
- 2SB808
- 2SC1843
- 2SC2603
- 2SC2320
- 2SD1012

- LOCATION OF COMPONENTS
- IC
- IC2 --- A2
 - IC2b --- C2
 - IC3 --- A1
 - IC3b --- C1
 - IC4 --- C4
 - IC4b --- D2
 - IC5 --- D4
 - IC5b --- D1
 - IC6 --- D3
 - IC7 --- B5
 - IC8 --- F5
 - IC9, 10 --- F3
 - IC11 --- E3
 - IC12 --- E4
 - IC13 --- E5
- TR
- TR1 to 3 --- A2
 - TR4 --- B2
 - TR4 --- A3
 - TR4b --- B3
 - TR5 --- B2
 - TR6 --- A2
 - TR7 --- B1
 - TR5b to 7b --- C2
 - TR8 to 10 --- C1
 - TR11 --- D1
 - TR11b --- E1
 - TR12, 12b --- E2
 - TR13 --- D1
 - TR13b --- E1
 - TR14 --- D2
 - TR14b --- E2
 - TR15, 15b --- E2
 - TR16, 17 --- E3
 - TR18, 18b --- E4
 - TR19 --- B2
 - TR19b --- D3
 - TR20 --- C4
 - TR21 --- C5
 - TR20b, 21b --- D2
 - TR22 --- C4
 - TR22b --- D1
 - TR23 --- C5
 - TR23b --- D2
 - TR24, 25 --- D3
 - TR26, 26b, 27 --- B5
 - TR28, 28b, 29 --- A4
 - TR30, 30b --- B5
 - TR31, 31b --- C5
 - TR32, 32b --- F4
 - TR33, 33b --- E3
 - TR34 to 37 --- E5
 - TR38, 39 --- F5
 - TR40, 41 --- F5
 - TR42 --- E5
 - TR43 --- F5
 - TR44, 45 --- F4
 - TR46 --- F5
 - TR47 to 49 --- D5
 - TR50, 51 --- C5
 - TR52, 53 --- D4
- TERMINAL
- ① to ③ --- E3
 - ④ to ⑥ --- E4
 - ⑦ to ⑨ --- F5
 - P15 --- E5
 - P16 --- A4
 - P17 --- E4
 - J6 --- C5
 - J9 --- A4
 - J11 --- D1
 - J13 --- D3

ARIOUS P.C BOARDS
T2032A501(2ED) and PHONE JACK P.C BOARD T2032A501B

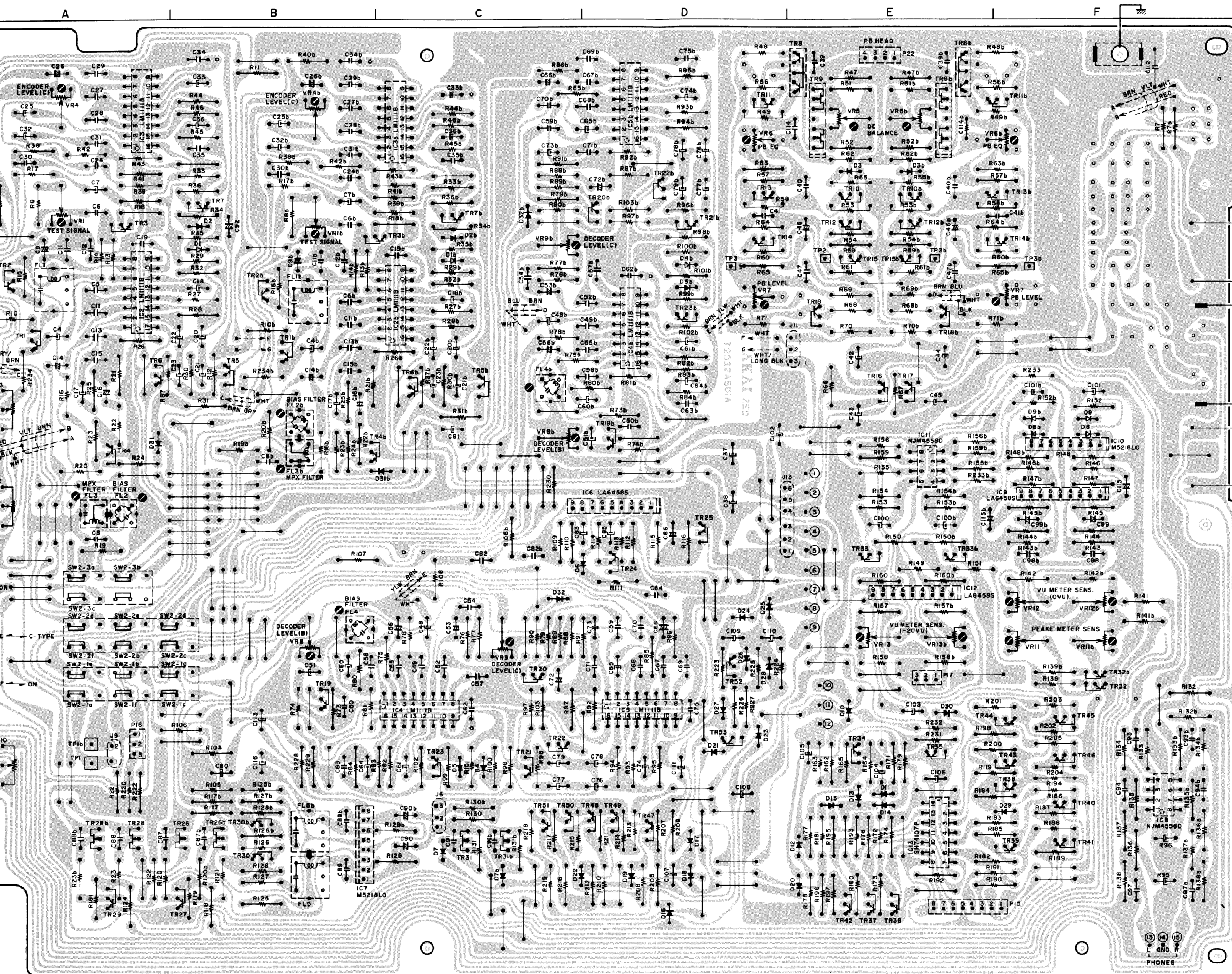

PRE AMP PCB T2032A501A

- TR1 to 7, 19 to 25, 27, 29, 30, 32, 34 to 39, 42 to 44, 47 to 50, 52 --- 25C2603(E, F)
- TR8 --- 25A995(E, F)
- TR9 --- 25K270(GR, BL)
- TR10, 12 --- 25C1843(E, F)
- TR11 --- 25A990(E, F)
- TR13, 14, 18 --- 25C2320(E, F)
- TR15 --- 25A999(E, F)
- TR16 --- 25D1012-V(F, G)
- TR17 --- 25B808-V(F, G)
- TR26, 28 --- 25K170(BL, V)
- TR31 --- 25K117(GR, BL)
- TR33, 40, 41, 45, 46, 51, 53 --- 25A1115(E, F)

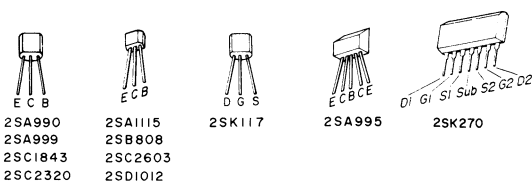

JACK PCB T2032A501B

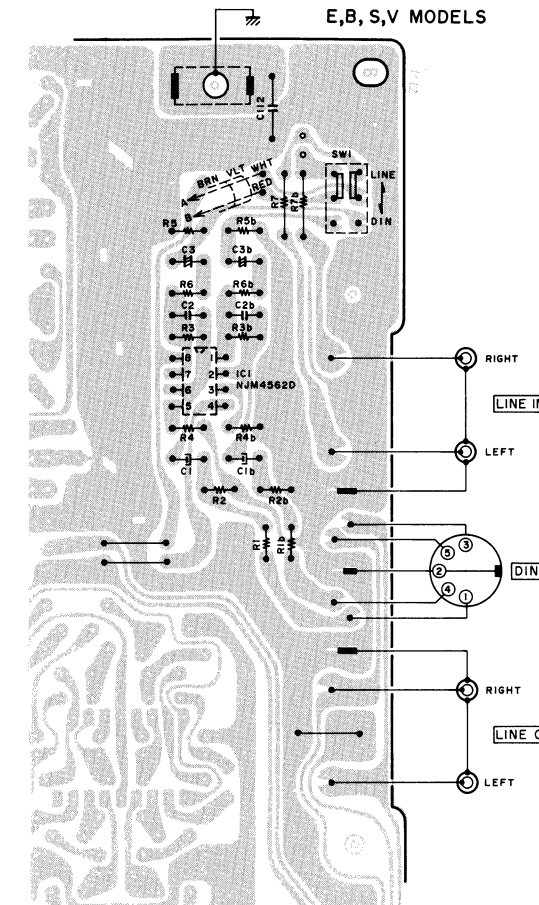

- LOCATION OF COMPONENTS
- IC
 IC2 ----- A2
 IC2b ----- C2
 IC3 ----- A1
 IC3b ----- C1
 IC4 ----- D2
 IC4b ----- D2
 IC5 ----- D4
 IC5b ----- D1
 IC6 ----- D3
 IC7 ----- B5
 IC8 ----- F5
 IC9, 10 ----- F3
 IC11 ----- E3
 IC12 ----- E4
 IC13 ----- E5
- TR
 TR1 to 3 ----- A2
 TR1b to 3b ----- B2
 TR4 ----- B3
 TR4b ----- A3
 TR5 ----- B2
 TR6 ----- A2
 TR7 ----- B1
 TR5b to 7b ----- C2
 TR8 to 10, 8b to 10b ----- D1
 TR11 ----- D1
 TR11b ----- E1
 TR12, 12b ----- E2
 TR13 ----- D1
 TR13b ----- E1
 TR14 ----- D2
 TR14b ----- E2
 TR15, 15b ----- E2
 TR16, 17 ----- E3
 TR18, 18b ----- E4
 TR19 ----- B2
 TR19b ----- D3
 TR20 ----- C4
 TR21 ----- C5
 TR20b, 21b ----- D2
 TR22 ----- C4
 TR22b ----- D1
 TR23 ----- C5
 TR23b ----- D2
 TR24, 25 ----- D3
 TR26, 26b, 27 ----- B5
 TR28, 28b, 29 ----- A4
 TR30, 30b ----- B5
 TR31, 31b ----- C5
 TR32, 32b ----- F4
 TR33, 33b ----- E3
 TR34 to 37 ----- E5
 TR38, 39 ----- F5
 TR40, 41 ----- F5
 TR42 ----- E5
 TR43 ----- F5
 TR44, 45 ----- F4
 TR46 ----- F5
 TR47 to 49 ----- D5
 TR50, 51 ----- C5
 TR52, 53 ----- D4
- TERMINAL
 ① to ⑤ ----- E3
 ⑥ to ⑩ ----- E4
 ⑪ to ⑭ ----- F5
 P15 ----- E5
 P16 ----- A4
 P17 ----- E4
 J6 ----- C5
 J9 ----- A4
 J11 ----- D1
 J13 ----- D3

2) SYSCON P.C BOARD T2032B502A (2ED), SWITCH P.C BOARD T2032B502B, TR P.C BOARD (A) T2032B502C and TR P.C BOARD (B) T2032B502D

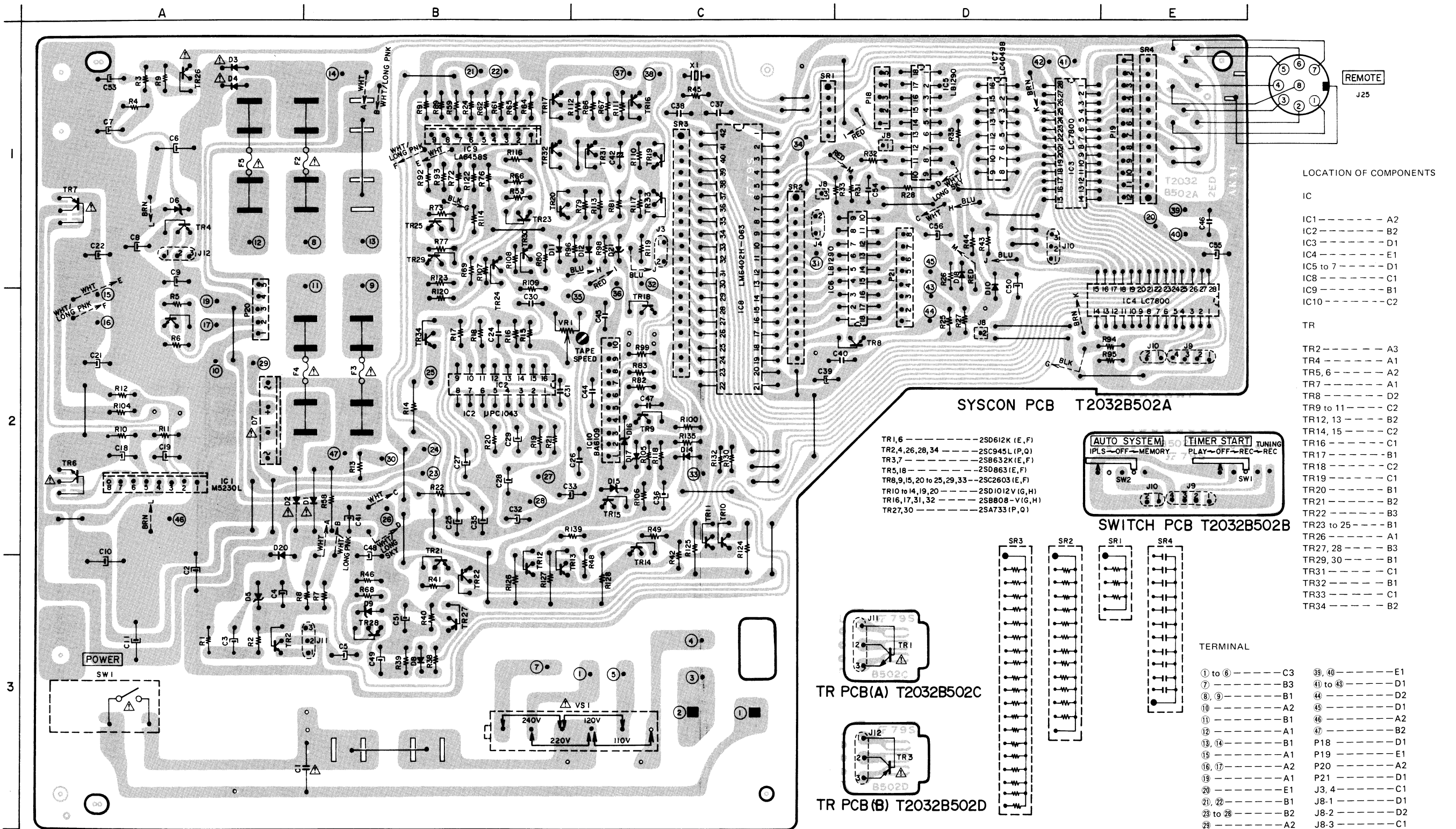

LOCATION OF COMPONENTS

- IC
- IC1 ----- A2
 - IC2 ----- B2
 - IC3 ----- D1
 - IC4 ----- E1
 - IC5 to 7 ----- D1
 - IC8 ----- C1
 - IC9 ----- B1
 - IC10 ----- C2
- TR
- TR2 ----- A3
 - TR4 ----- A1
 - TR5, 6 ----- A2
 - TR7 ----- A1
 - TR8 ----- D2
 - TR9 to 11 ----- C2
 - TR12, 13 ----- B2
 - TR14, 15 ----- C2
 - TR16 ----- C1
 - TR17 ----- B1
 - TR18 ----- C2
 - TR19 ----- C1
 - TR20 ----- B1
 - TR21 ----- B2
 - TR22 ----- B3
 - TR23 to 25 ----- B1
 - TR26 ----- A1
 - TR27, 28 ----- B3
 - TR29, 30 ----- B1
 - TR31 ----- C1
 - TR32 ----- B1
 - TR33 ----- C1
 - TR34 ----- B2

- TR1, 6 ----- 2SD612K (E, F)
- TR2, 4, 26, 28, 34 ----- 2SC945L (P, Q)
- TR3, 7 ----- 2SB632K (E, F)
- TR5, 18 ----- 2SD863 (E, F)
- TR8, 9, 15, 20 to 25, 29, 33 ----- 2SC2603 (E, F)
- TR10 to 14, 19, 20 ----- 2SD1012V (G, H)
- TR16, 17, 31, 32 ----- 2SB808-V (G, H)
- TR27, 30 ----- 2SA733 (P, Q)

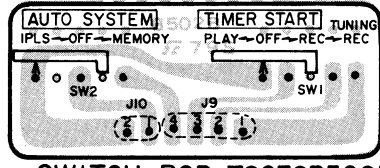

SWITCH PCB T2032B502B

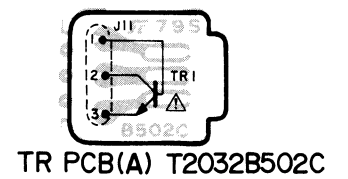

TR PCB(A) T2032B502C

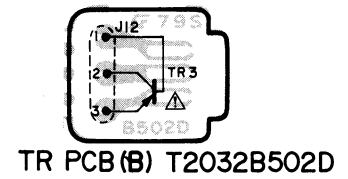

TR PCB(B) T2032B502D

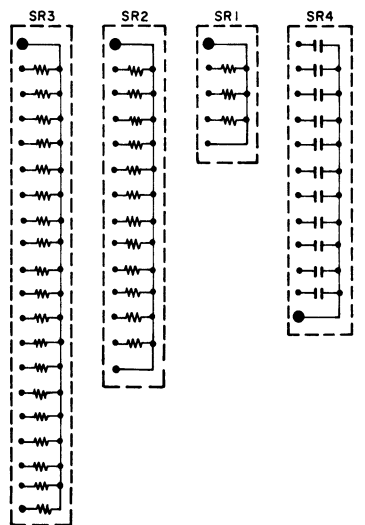

TERMINAL

- ① to ⑥ ----- C3
- ⑦ ----- B3
- ⑧, ⑨ ----- B1
- ⑩ ----- A2
- ⑪ ----- B1
- ⑫ ----- A1
- ⑬, ⑭ ----- B1
- ⑮ ----- A1
- ⑯, ⑰ ----- A2
- ⑱ ----- A1
- ⑳ ----- E1
- ㉑, ㉒ ----- B1
- ㉓ to ㉔ ----- B2
- ㉕ ----- A2
- ㉖ ----- B2
- ㉗, ㉘ ----- C1
- ㉙ ----- B2
- ㉚, ㉛ ----- C1
- ㉜ to ㉝ ----- C1
- ⑳, ㉞ ----- E1
- ㉟, ㊱ ----- D1
- ㊲ ----- D2
- ㊳ ----- C1
- ㊴, ㊵ ----- E2
- ㊶ ----- D1
- ㊷ ----- D1
- ㊸ ----- B3
- ㊹ to ㊺ ----- A1
- ㊻, ㊼ ----- E1
- ㊽ ----- D1
- ㊾ ----- D2
- ㊿ ----- C1

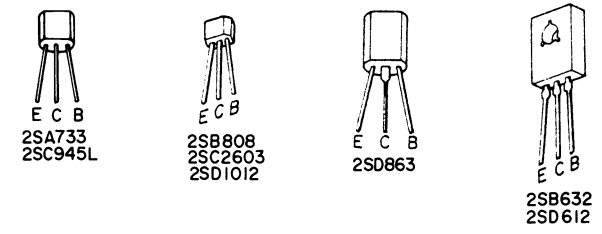

WARNING: Δ INDICATES SAFETY CRITICAL COMPONENTS. FOR CONTINUED SAFETY, REPLACE SAFETY CRITICAL COMPONENTS ONLY WITH MANUFACTURER'S RECOMMENDED PARTS.

AVERTISSEMENT: Δ IL INDIQU LES COMPOSANTS CRITIQUES DE SÛRETÉ. POUR MAINTENIR LE DEGRÉ DE SÛRETÉ DE L'APPAREIL, NE REMPLACER LES COMPOSANTS DONT LE FONCTIONNEMENT EST CRITIQUE POUR LA SÛRETÉ QUE PAR DES PIÈCES RECOMMANDÉES PAR LE FABRICANT.

4) METER P.C BOARD T2032B5040

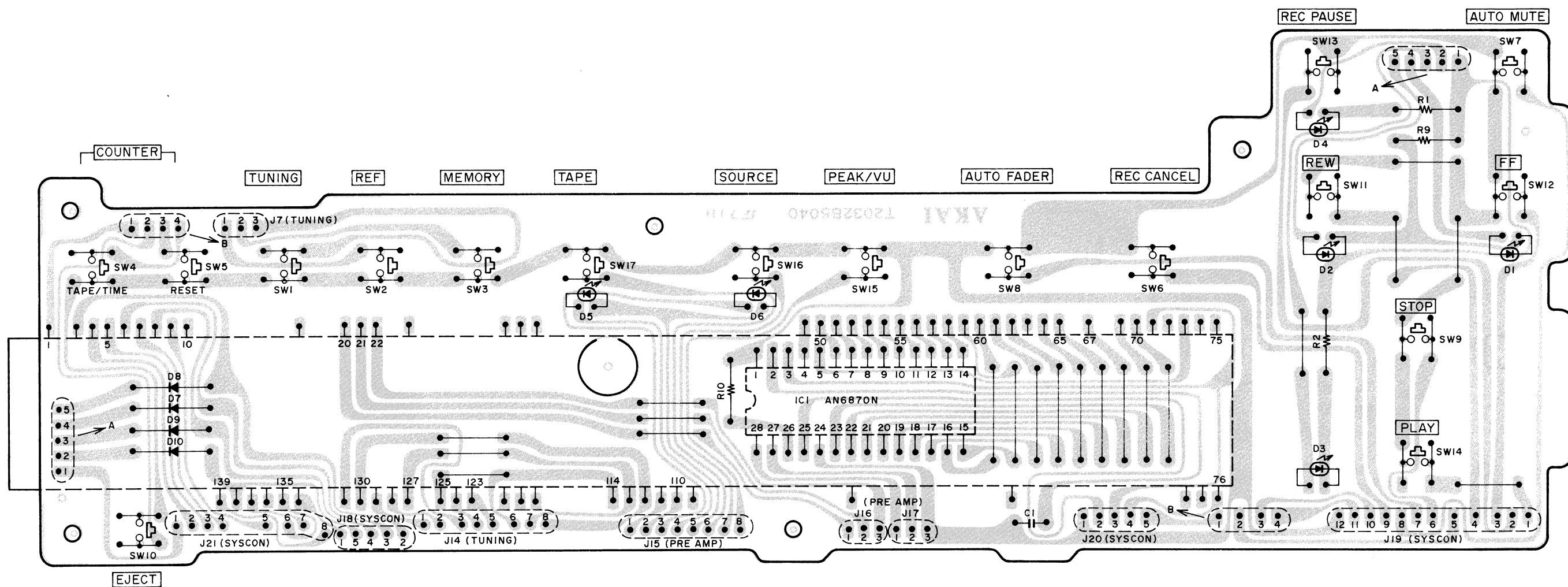

5) MOTOR P.C BOARD M3103C726A and POTENTION P.C BOARD M3103C726B

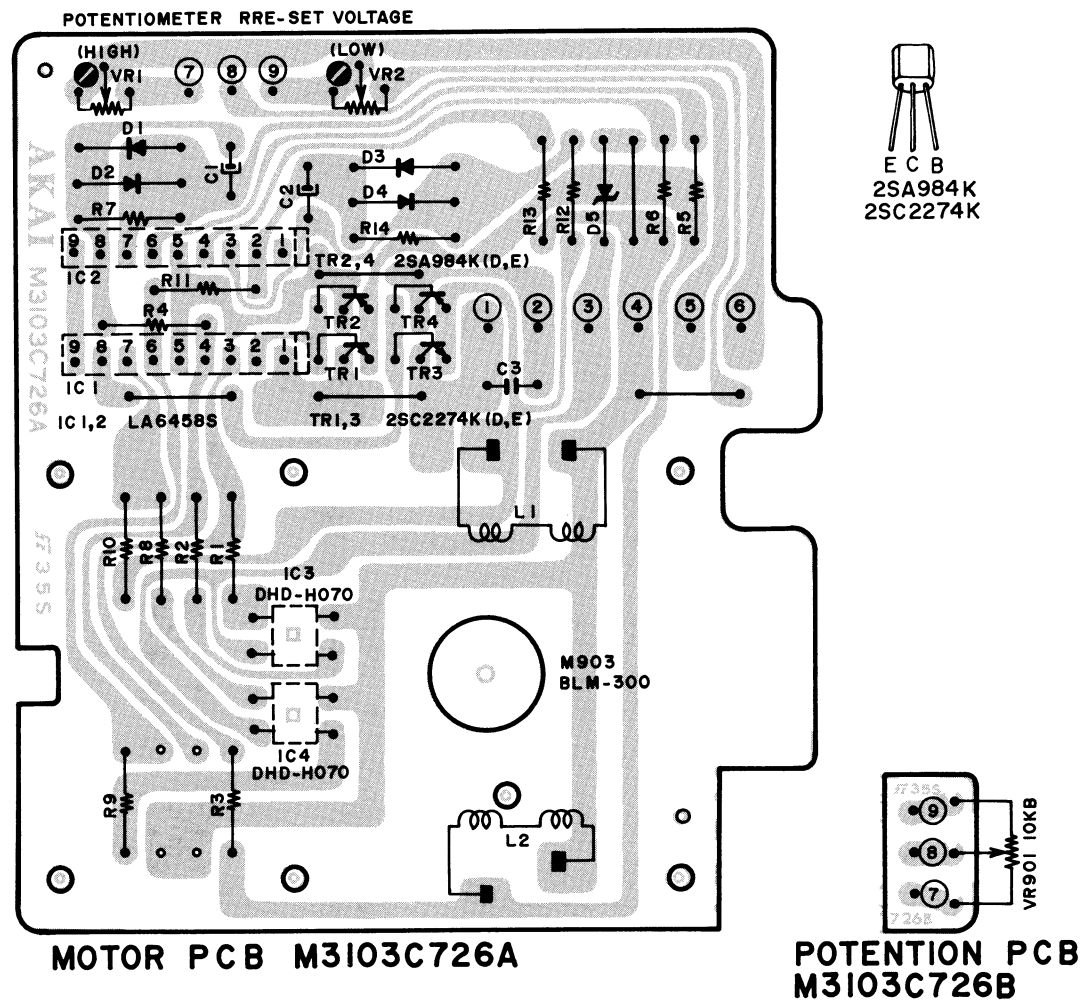

7) FILTER P.C BOARD T2029D5040

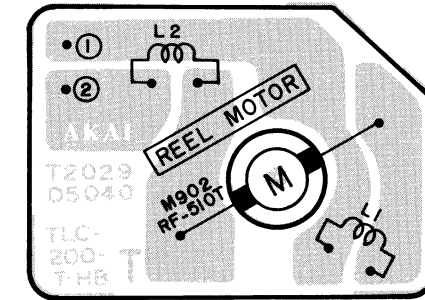

8) DETECTOR P.C BOARD T2029D5030

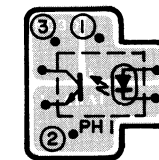

9) MICRO SW P.C BOARD T2029D5020

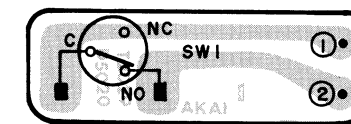

6) FG P.C BOARD M3103C7130

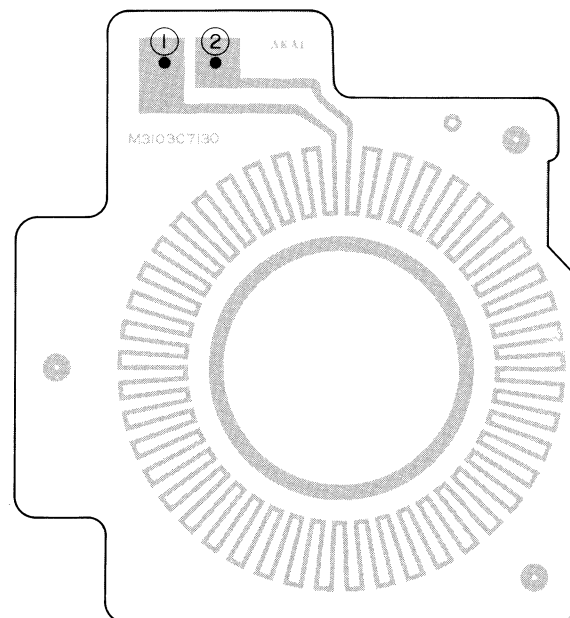

MEMO

MEMO

MEMO

MEMO

SECTION 5

PARTS LIST

TABLE OF CONTENTS

I. MODEL GX-F31

RECOMMENDED SPARE PARTS 5- 3

1. MECHA BLOCK 5- 4

2. MOTOR BLOCK 5- 6

3. PRE AMP P.C BOARD BLOCK 5- 8

4. SYS. CON. P.C BOARD BLOCK 5- 9

5. METER/OPERATE P.C BOARD BLOCK 5- 9

6. MOTOR P.C BOARD BLOCK 5- 9

7. ASSEMBLY BLOCK 5-10

8. FINAL ASSEMBLY BLOCK 5-12

II. MODEL GX-F51

RECOMMENDED SPARE PARTS 5-13

1. MECHA BLOCK 5-14

2. MOTOR BLOCK 5-16

3. PRE AMP P.C BOARD BLOCK 5-18

4. SYS. CON. P.C BOARD BLOCK 5-19

5. TUNING P.C BOARD BLOCK 5-19

6. METER/OPERATE P.C BOARD BLOCK 5-19

7. MOTOR P.C BOARD BLOCK 5-19

8. ASSEMBLY BLOCK 5-20

9. FINAL ASSEMBLY BLOCK 5-22

III. MODEL GX-F71

RECOMMENDED SPARE PARTS 5-23

1. MECHA BLOCK 5-24

2. MOTOR BLOCK 5-26

3. PRE AMP P.C BOARD BLOCK 5-28

4. SYS. CON. P.C BOARD BLOCK 5-29

5. TUNING P.C BOARD BLOCK 5-29

6. METER P.C BOARD BLOCK 5-30

7. MOTOR P.C BOARD BLOCK 5-30

8. ASSEMBLY BLOCK 5-30

9. FINAL ASSEMBLY BLOCK 5-32

INDEX

1. MODEL GX-F31 5-33

2. MODEL GX-F51 5-34

3. MODEL GX-F71 5-35

Resistor and Capacitor which is not listed in this parts list, please refer to COMMON LIST FOR SERVICE PARTS.

ATTENTION

1. When placing an order for parts, be sure to list the parts no., model no., and description. There are instances in which if any of this information is omitted, parts cannot be shipped or the wrong parts will be delivered.
2. Please be careful not to make a mistake in the parts no. If the parts no. is in error, a part different from the one ordered may be delivered.
3. Because parts number and parts unit supply in the Preliminary Parts List may be partially changed, please use this parts list for all future reference.

HOW TO USE THIS PARTS LIST

1. This Parts List shows the parts that are considered necessary for repairs. Other parts, such as resistors and capacitors, are shown in the "Common List for Service Parts". Select and order such parts from the "Common List for Service Parts".
2. The Recommended Spare Parts shows those parts in the Parts List which are considered particularly important for service.
3. Parts not shown in the Parts List and "Common List for Service Parts" will not be supplied in principle.
4. How to read list
 - a) Mechanism Block
 - b) P.C Board Block

2. HEAD BASE BLOCK

REF. NO.	PARTS NO.	DESCRIPTION
2-1x	BH-T2023A320A	HEAD BASE BLOCK GX-F66R
2-2	HP-H2206A010A	HEAD R/P PR4-8FU C
2-3	ZS-477876	PAN20x03STL CMT
2-4	ZS-536488	BID20x08STL CMT
2-5	ZG-402895	CS ANGLE ADJUST SPRING

SP (Service Parts) Classification
 A small "x" indicates the inability to show that particular part in the Photo or Illustration.
 This number corresponds with the individual parts index number in that figure
 This number corresponds with the Figure Number

6. SYS. CON. P.C BOARD BLOCK

REF. NO.	PARTS NO.	DESCRIPTION
6-1	BA-T2034A070A	PC SYS CON BLK GX-F44R
6-IC1	EI-324536	IC HD14049BP
6-IC2	EI-336801	IC MB8841-564M
6-IC3	EI-331661	IC SN7405N
6-IC4	EI-336725	IC M54527P
6-TR1to4	ET-200985	TR 2SC2603 F,G
6-TR5to28	ET-554657	TR 2SA733A P,Q
6-D1	ED-318292	D SILICON H 1S2473T-77 T26
6-D2to4	ED-308952	D GERMA V 1K34A-LR F07
6-D5to10	ED-318292	D SILICON H 1S2473T-77 T26
6-X1	EI-318384	OSC X'TAL NC-18C 3.579545MHZ

SP (Service Parts) Classification
 This reference numbers corresponds with symbol numbers of Schematic Diagrams.

5. Both the kind of part and installation position can be determined by the Parts Number. To determine where a parts number is listed, utilize Parts Index at end of Parts List. It is necessary first of all to find the Parts Number. This can be accomplished by using the Reference Number listed at right of parts number in the Parts Index.

WARNING

⚠ INDICATES SAFETY CRITICAL COMPONENTS. FOR CONTINUED SAFETY, REPLACE SAFETY CRITICAL COMPONENTS ONLY WITH MANUFACTURER'S RECOMMENDED PARTS.

AVERTISSEMENT

⚠ IL INDIQUE LES COMPOSANTS CRITIQUES DE SURETE. POUR MAINTENIR LE DEGRE DE SECURITE DE L'APPAREIL NE REMPLACER LES COMPOSANTS DONT LE FONCTIONNEMENT EST CRITIQUE POUR LA SECURITE QUE PAR DES PIECES RECOMMANDEES PAR LE FABRICANT.

I. MODEL GX-F31

RECOMMENDED SPARE PARTS

Because, if the parts listed below are on hand, almost any repair can be accomplished, we suggest that you stock these Recommended Spare Parts Items.

NO.	PARTS NO.	DESCRIPTION	NO.	PARTS NO.	DESCRIPTION
1	BF-B336013	FLYWHEEL PART	64	EO-337044	COIL FIX 2 102AK-005 36MH
2	BH-T2029A070A	HEAD BLK GX-F31	65	EO-337046	COIL OSC 1 0365-028 100KHZ
3	BL-B336150	ARM PINCH ROLLER (A) PART	66	EO-315758	COIL TUN 1 100S-431 100KHZ
4	BM-M3103A010A	△ MOTOR BLM-300	67	EO-337055	COIL VARI 1 FE002S 10MH
5	BM-B337064	△ MOTOR OPERATION (PULLEY) PART	68	EP-322437	RELAY LEAD LAB2NS 2NO 5V
6	BM-B336989	△ REEL MOTOR (PULLEY) PART	69	ER-337287	△ R FUSE ERD2FC 1/4W 20R0G
7	BM-T2030A120A	△ REEL MOTOR BLK GX-F51	70	ER-307565	△ R FUSE ERD2FC 1/4W 6R8J
8	BR-336606	REEL TABLE ASSY	71	ER-336775	FILTER DB D07001K 19KHZ
9	BT-337246	△ TRANS POWER T-2030(A,C)	72	ER-336776	FILTER DB D07003K 100KHZ
10	BT-337248	△ TRANS POWER T-2030(B,S)	73	ER-337376	R COMP 01-0399
11	BT-337247	△ TRANS POWER T-2030(E,V)	74	ER-337374	R COMP 01-0400
12	BT-337245	△ TRANS POWER T-2030(J)	75	ER-337631	R COMP 01-0449
13	BT-337244	△ TRANS POWER T-2030(U)	76	ES-312234	△ SW PUSH SDL-1P 01-1 E (U,E,B,S,V)
14	BZ-T2030A110A	OIL CLUTCH BLK GX-F51	77	ES-312235	△ SW PUSH SDL-1P 01-1 J (J)
15	EC-338341	C COMP 05-0034	78	ES-312238	△ SW PUSH SDL-1P 01-1 UC (C,A)
16	EC-337017	OSC CE CSB800A 0.8MHZ	79	ES-336990	SW LEAF BSW-1609 01-1 NO
17	ED-322982	D GERMA V 1S188FM-1-LR F07	80	ES-337344	SW MICRO SS-01-ED UC
18	ED-337016	D LED SG203DA GRN	81	ES-337045	SW PUSH SUN312A 3-THROW
19	ED-337010	D LED SLF-201C GRN	82	ES-337043	SW ROTARY SRU1023 1-02-03N
20	ED-337014	D LED SR503D RED	83	ES-336780	SW TACT KHH10902
21	ED-301911	D SILICON H DS448	84	ET-311977	PHOTO SENSOR SPI-201
22	ED-200469	D SILICON H DS448 FA5 F10	85	ET-321016	TR FET 2SK117 GR,BL
23	ED-316143	D SILICON H 1S2473HS F10	86	ET-200558	TR 2SA1115 E,F
24	ED-200468	D SILICON V DS448-VB6	87	ET-554657	TR 2SA733A P,Q
25	ED-306109	D SILIOCN W03B 100/1.0A	88	ET-337012	TR 2SA984K D,E
26	ED-322238	D SILICON 1B4B41 100/1.0A	89	ET-322598	TR 2SB632K E,F
27	ED-338561	D ZENER H HZ2 F10 B2	90	ET-328438	TR 2SB808-V F,G
28	ED-338403	D ZENER V HZ11B-1S1	91	ET-308976	TR 2SC1815 BL,GR
29	ED-338413	D ZENER V HZ24-2S1	92	ET-331279	TR 2SC1843 P,F SNP
30	ED-338412	D ZENER V HZ27-3S1	93	ET-309353	TR 2SC2274 E,F
31	ED-337289	D ZENER V HZ5A-1S1	94	ET-337011	TR 2SC2274K D,E
32	ED-337019	D ZENER V HZ6A-1S1	95	ET-310833	TR 2SC2274K E
33	EF-300588	△ FUSE EAWK T 250V 0.20A (E,B,S,V) (F6)	96	ET-200505	TR 2SC2603 E,F
34	EF-330462	△ FUSE GGS A 250V 0.20A (C,A) (F6)	97	ET-328437	TR 2SD1012-V F,G
35	EF-593706	△ FUSE SEMKO T 250V 0.50A (E,B,S,V) (F3)	98	ET-328868	TR 2SD1012-V G,H
36	EF-593706	△ FUSE SEMKO T 250V 0.50A (E,B,S,V) (F2)	99	ET-452531	TR 2SD313 E
37	EF-602550	△ FUSE SEMKO T 250V 1.25A (E,B,S,V) (F4,5)	100	ET-310148	TR 2SD612K E,F
38	EF-623103	△ FUSE SEMKO T 250V 1A(B)(F1)	101	ET-318239	TR 2SD863 E,F
39	EF-327103	△ FUSE TSC A 250V 0.50A(U,J)(F2)	102	EV-315416	R S-FIX H D8 3P 103
40	EF-327103	△ FUSE TSC A 250V 0.50A(U,J)(F3)	103	EV-315414	R S-FIX H D8 3P 203
41	EF-306949	△ FUSE TSC A 250V 1.25A (U,J) (F4,5)	104	EV-315412	R S-FIX H D8 3P 502
42	EF-309390	△ FUSE TSC 125V 0.50A (C,A)(F3)	105	EV-315413	R S-FIX H D8 3P 503
43	EF-309390	△ FUSE TSC 125V 0.50A (C,A)(F2)	106	EV-336785	R S-FIX H TM8KV2-1S 3P 0.50W 104
44	EF-309392	△ FUSE TSC 125V 1.25A (C,A)(F4,5)	107	EV-464220	R S-FIX H V8K4-1 3P 503
45	EI-337568	HOLE ELEMENT DHD-H070	108	EV-464253	R S-FIX V V8K1-1 3P 202
46	EI-330352	IC BA6109	109	EV-337052	VR ROTARY 16L10×OR B103
47	EI-315799	IC HA12019	110	EV-337028	VR ROTARY 16P20×20 A204
48	EI-336983	IC HA12038	111	EV-337029	VR ROTARY 16P20×2P M204 N204
49	EI-336761	IC LA6458S	112	EV-337030	VR ROTARY 16P20×2Q B103
50	EI-337013	IC LB1290	113	HE-337047	HEAD E HJ213270 C
51	EI-337009	IC LC4049	114	HP-H2201A010A	HEAD R/P PR4-7 C
52	EI-337008	IC LC7800	115	MB-336021	BELT OPERATION
53	EI-337006	IC LM6402H-063	116	MP-336153	PINCH ROLLER (A)
54	EI-337228	IC M5218L0	117	TC-336002	HOLDER CAPSTAN (B)
55	EI-336994	IC M5230L	118	TC-336004B	HOLDER CAPSTAN (C-2)
56	EI-201940	IC NJM4558S	119	TC-336605	WIND IDLER ASSY
57	EI-200938	IC TA7558S			
58	EI-336992	IC μPC1043			
59	EI-338392	IC μPC1224H			
60	EJ-283140	△ SOCKET SELECTER X-17238 6P (U)			
61	EJ-337654	DIN J UC-0044 P 8P			
62	EL-337053	PL CORD 16.0V 80MA 400/400			
63	EM-336988	IND FL FIP48BW11Y DOUBLE			

When ordering parts, please quote Parts Number, Description and Model Number.

MECHA BLOCK

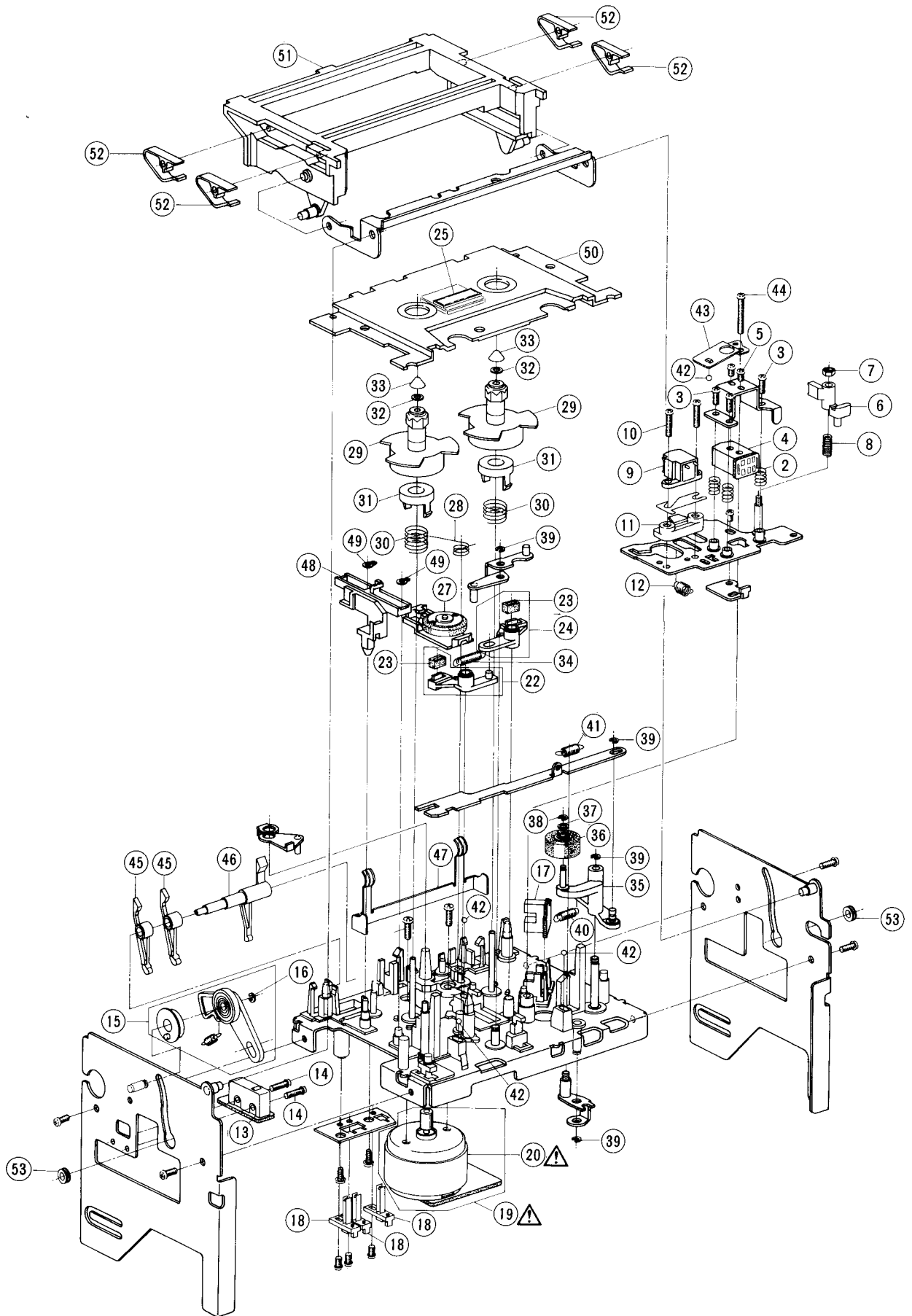

1. MECHA BLOCK

REF. NO.	PARTS NO.	DESCRIPTION
HEAD BLOCK		
1-1x	BH-T2029A070A	HEAD BLK GX-F31
1-2	ZG-336127	SP PUSH HEAD
1-3	ZS-608106	PAN20×06STL CMT
1-4	HP-H2201A010A	HEAD R/P PR4-7 C
1-5	ZS-477876	PAN20×03STL CMT
1-6	HZ-336129	GUIDE TAPE
1-7	ZW-618884	N20STL CMT 1
1-8	ZG-336130	SP PUSH GUIDE
1-9	HE-337047	HEAD E HJ213270 C
1-10	ZS-465298	PAN23×10STL CMT
1-11	HZ-336131	HOLDER E HEAD
1-12	ZG-341972	SP PULL HEAD RETURN
SW MICRO P.C BOARD BLOCK		
1-13	ES-337344	SW MICRO SS-01-ED UC (SW1)
CHASSIS MECHA SIDE (L) BLOCK		
1-14	ZS-310337	PAN20×08STL CMT
1-15	BZ-T2030A110A	OIL CLUTCH BLK GX-F51
1-16	ZW-270088	RING E 190SUP CMT
DETECTION P.C BOARD BLOCK		
1-17	ET-311977	PHOTO SENSOR SPI-201 (PH1)
SW LEAF BLOCK		
1-18	ES-336990	△ SW LEAF BSW-169 01-1 NO (SW902,903,904)
REEL MOTOR BLOCK		
1-19	BM-T2030A120A	△ REEL MOTOR BLK GX-F51
1-20	BM-B336989	△ REEL MOTOR (PULLEY) PART
1-21x	EO-669273	COIL FIX 2 FL5R200 18μH (L1,2)
LEVER BRAKE (A) BLOCK		
1-22	BL-T2030A160A	LEVER BRAKE (A) BLK GX-F51
1-23	TC-336146	BRAKE RUBBER
LEVER BRAKE (B) BLOCK		
1-24	BL-T2030A170A	LEVER BRAKE (B) BLK GX-F51
D LED BLOCK		
1-25	ED-337010	D LED SLF-201C GRN (D901)
MECHA BLOCK		
1-26x	BZ-T2029A080A	MECHA BLK GX-F31
1-27	TC-336605	WIND IDLER ASSY
1-28	ZG-336140	SP TORSION IDLER
1-29	BR-336606	REEL TABLE ASSY
1-30	ZG-336141	SP PUSH BT
1-31	TC-336142	HOLDER BT SP
1-32	ZW-330073	PW21×040×020
1-33	MT-305793	REEL CAP
1-34	ZG-312946	SP T1-3.2/0.29-16.0 T1-062
1-35	BL-B336150	ARM PINCH ROLLER (A) PART
1-36	MP-336153	PINCH ROLLER (A)
1-37	ZW-381644	PW21×040×013PSL
1-38	ZW-356657	RING E 150SUP CMT
1-39	ZW-270088	RING E 190SUP CMT
1-40	ZG-342575	SP PULL PINCH ROLLER (T-2)
1-41	ZG-321534	SP T2-3.2/0.29-12.5 T2-060
1-42	MV-357208	BALL200STL
1-43	ZG-336157	SP PLATE HEAD HOLD
1-44	ZS-342002	ST PAN26×16STL CMT
1-45	ML-336158	LEVER DETECTION (B)
1-46	ML-336159	LEVER DETECTION (A)
1-47	ZG-336160	SP PLATE CASSETTE HOLDER (A)
1-48	TC-336161	SLIDE EJECT
1-49	ZW-336603	RING GRIP 285SUP ACP
1-50	BD-B336162B	LID DECORATION (B) PART
1-51	SP-336163	LID CASE
1-52	ZG-336615	SP PLATE CASSETTE HOLDER (B)
1-53	SZ-336166	COLLAR LID

MOTOR BLOCK

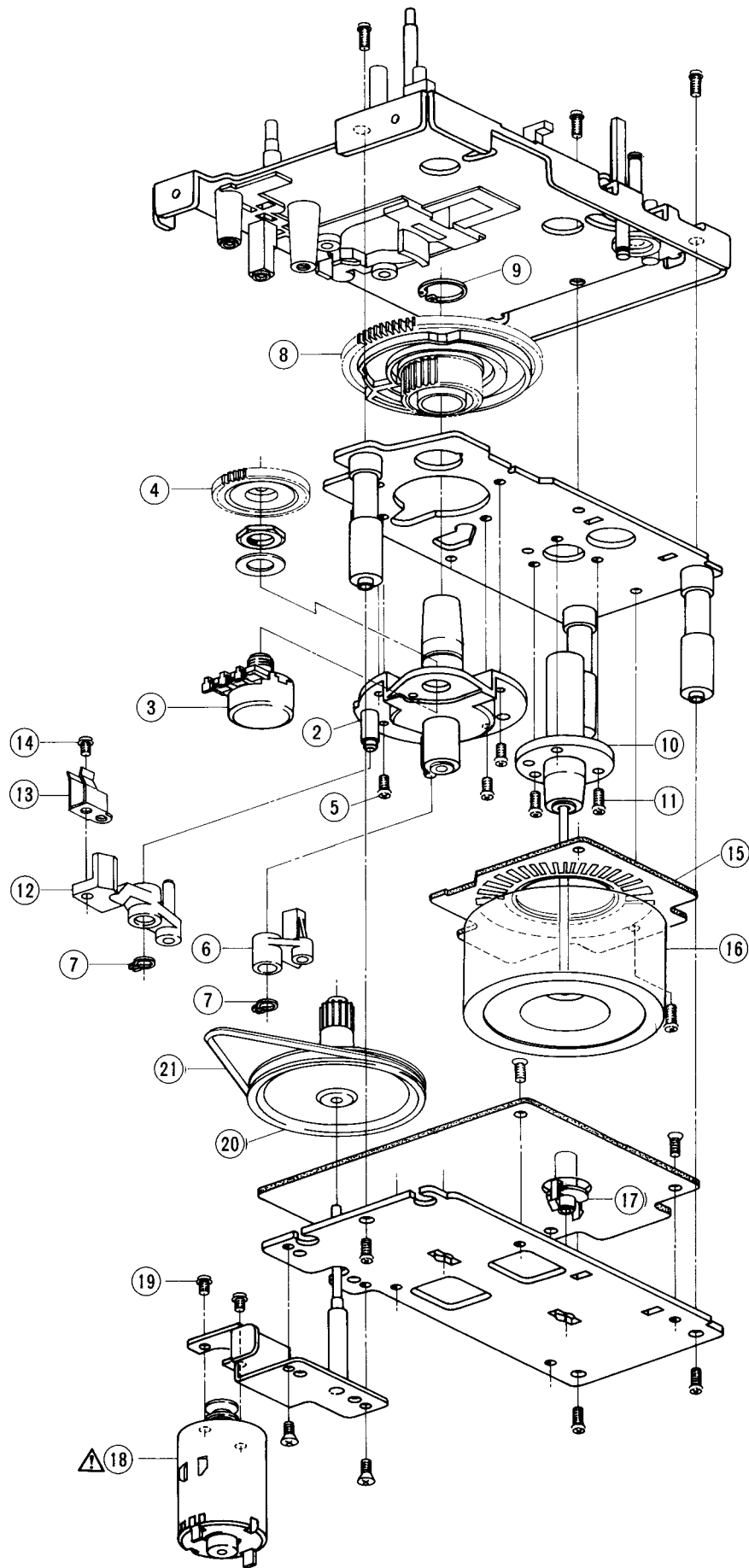

2. MOTOR BLOCK

REF. NO.	PARTS NO.	DESCRIPTION
2-1x	BM-M3103A010A	MOTOR BLM-300
2-2	TC-336004B	HOLDER CAPSTAN (C-2)
2-3	EV-337052	VR ROTARY 16L10xOR B103
2-4	MZ-336005	GEAR POTENTION
2-5	ZS-432843	PAN26x04STL CMT
2-6	BL-B336007	LEVER BRAKE CAM PART
2-7	ZW-336603	RING GRIP 285SUP ACP
2-8	MZ-336006	CAM WHEEL
2-9	ZW-336604	RING S839SUP ACP
2-10	TC-336002	HOLDER CAPSTAN (B)
2-11	ZS-479474	PAN26x05STL CMT
2-12	BL-B336009	LEVER EJECT CAM PART
2-13	ZG-336011	SP PLATE CAM LEVER
2-14	ZS-477876	PAN20x03STL CMT
2-15	EA-336012	PC FG
2-16	BF-B336013	FLYWHEEL PART
2-17	TC-336016	HOLDER THRUST (A)
2-18	BM-B337064	MOTOR OPERATION (PULLEY) PART
2-19	ZS-477876	PAN20x03STL CMT
2-20	MR-336019	PULLEY OPERATE
2-21	MB-336021	BELT OPERATION

3. PRE AMP P.C BOARD BLOCK

REF. NO.	PARTS NO.	DESCRIPTION
3-1	BA-T2029A030A	PC PRE AMP BLK GX-F31(U) (U,J,C,A)
3-2	BA-T2029A030B	PC PRE AMP BLK GX-F31(E) (E,B,S,V)
3-3	BA-T2029A030C	PC PRE AMP BLK GX-F31-P(U) (U,J,C,A)
3-4	BA-T2029A030D	PC PRE AMP BLK GX-F31-P(E) (E,B,S,V)

PRE AMP P.C BOARD

3-IC1	EI-200938	IC TA75558S
3-IC2	EI-336983	IC HA12038
3-IC3	EI-337228	IC M5218L0
3-IC4	EI-336761	IC LA6458S
3-IC6	EI-338392	IC μ PC1224H
3-IC7	EI-336761	IC LA6458S
3-IC8	EI-336761	IC LA6458S
3-TR2	ET-200505	TR 2SC2603 E,F
3-TR4	ET-200505	TR 2SC2603 E,F
3-TR6	ET-200505	TR 2SC2603 E,F
3-TR7,8	ET-200558	TR 2SA1115 E,F
3-TR9to16	ET-200505	TR 2SC2603 E,F
3-TR17	ET-328868	TR 2SD1012-V G,H
3-TR18	ET-331279	TR 2SC1843 P,F SNP
3-TR19to21	ET-328868	TR 2SD1012-V G,H
3-TR22to27	ET-200505	TR 2SC2603 E,F
3-TR28	ET-322598	TR 2SB632K E,F
3-TR29	ET-308976	TR 2SC1815 BL,GR
3-TR30	ET-200505	TR 2SC2603 E,F
3-TR31,32	ET-310833	TR 2SC2274K E
3-TR33	ET-309353	TR 2SC2274 E,F
3-TR34	ET-200505	TR 2SC2603 E,F
3-TR36	ET-321016	TR FET 2SK117 GR,BL
3-TR37	ET-200505	TR 2SC2603 E,F
3-TR38	ET-328437	TR 2SD1012-V F,G
3-TR39	ET-328438	TR 2SB808-V F,G
3-TR40	ET-200505	TR 2SC2603 E,F
3-D2	ED-337292	D ZENER H HZ5 B1
3-D3	ED-322982	D GERMA V 1S188FM-1-LR F07
3-D4	ED-301911	D SILICON H DS448
3-D6to11	ED-301911	D SILICON H DS448
3-D13	ED-301911	D SILICON H DS448
3-D14	ED-200468	D SILICON V DS448-VB6
3-D16to21	ED-301911	D SILICON H DS448
3-D22	ED-338413	D ZENER V HZ24-2S1
3-D23	ED-301911	D SILICON H DS448
3-J1	EJ-337027	PHONE J THROW HLJ4353-210 2x3P
3-J1	EJ-337024	PHONE J THROW HLJ4353-010 2x3P (P)
3-J2	EJ-332435	PIN J P 4P (U,J,C,A)
3-J2	EJ-332437	JACK PLATE (E,B,S,V)
3-SW1	ES-337045	SW PUSH SUN312A 3-THROW
3-VR1	EV-337029	VR ROTARY 16P20x2P M204 N204
3-VR2	EV-337028	VR ROTARY 16P20x20 A204
3-VR3	EV-337030	VR ROTARY 16P20x2Q B103
3-VR4	EV-315414	R S-FIX H D8 3P 203
3-VR5	EV-315413	R S-FIX H D8 3P 503
3-VR6	EV-315416	R S-FIX H D8 3P 103
3-VR8	EV-315416	R S-FIX H D8 3P 103
3-VR9	EV-315412	R S-FIX H D8 3P 502
3-VR10	EV-315416	R S-FIX H D8 3P 103
3-VR11,12	EV-336785	R S-FIX H TM8KV2-1S 3P 0.50W 104
3-L1	EO-669273	COIL FIX 2 FL5R200 18 μ H
3-T1	EO-337046	COIL OSC 1 0365-028 100KHZ
3-FL1	EO-337044	COIL FIX 2 102AK-005 36MH
3-FL2	EO-337055	COIL VARI 1 FE002S 10MH
3-FL3	ER-336776	FILTER DB D07003K 100KHZ
3-FL4	ER-336775	FILTER DB D07001K 19KHZ
3-FL5,6	EO-315758	COIL TUN 1 100S-431 100KHZ
3-RL1	EP-322437	RELAY LEAD LAB2NS 2NO 5V
3-FR1,2	ER-307565	Δ R FUSE ERD2FC 1/4W 6R8J

REF. NO.	PARTS NO.	DESCRIPTION
3-C4	EC-313532	C EC V F05 NP 04D 1R0M 50.0DC
3-C63	EC-331631	C STY V SNP CQFS 821J 50DC
3-C65	EC-338042	C EC V F05 NP NXA 2R2M 50DC
3-C75	EC-314992	C STY V F05 CQF09 681J 50DC
3-C77	EC-315335	C EC V F05 NP 04D 4R7M 25DC
3-C81	EC-308877	C EC V F05 NP 04D 3R3M 25DC
3-C92	EC-337005	C PP V F10 ECQ-F 152J 630DC
3-C93,94	EC-270483	C MC V FM 101J 500DC
3-C98	EC-306017	C STY V F05 CQ09S 221J 50DC

PHONE JACK P.C BOARD

3-J3	EJ-336885	PHONE J 3P HLJ0607-023 6.3
3-J3	EJ-336886	PHONE J 3P HLJ0607-020 6.3 (P)

4. SYS. CON. P.C BOARD BLOCK

REF. NO.	PARTS NO.	DESCRIPTION
4-1	BA-T2029A040A	PC SYS CON BLK GX-F31(U)
4-2	BA-T2029A040B	PC SYS CON BLK GX-F31(J)
4-3	BA-T2029A040C	PC SYS CON BLK GX-F31(C) (C,A)
4-4	BA-T2029A040D	PC SYS CON BLK GX-F31(C) (E,S,V)
4-5	BA-T2029A040E	PC SYS CON BLK GX-F31(B)

SYS. CON. P.C BOARD BLOCK

4-IC1	EI-337006	IC LM6402H-063
4-IC2,3	EI-337013	IC LB1290
4-IC4,5	EI-337008	IC LC7800
4-IC6	EI-337009	IC LC4049
4-IC7	EI-336761	IC LA6458S
4-IC8	EI-330352	IC BA6109
4-IC9	EI-336992	IC μ PC1043
4-IC10	EI-336994	Δ IC M5230L
4-TR1	ET-322598	Δ TR 2SB632K E,F
4-TR2,3	ET-310148	Δ TR 2SD612K E,F
4-TR4	ET-308976	TR 2SC1815 BL,GR
4-TR5	ET-318239	Δ TR 2SD863 E,F
4-TR6	ET-310148	Δ TR 2SD612K E,F
4-TR7	ET-452531	Δ TR 2SD313 E,F
4-TR8	ET-308976	TR 2SC1815 BL,GR
4-TR9to17	ET-200505	TR 2SC2603 E,F
4-TR18to21	ET-336997	TR 2SB808-V G,H
4-TR22,23	ET-328868	TR 2SD1012-V G,H
4-TR24to27	ET-200505	TR 2SC2603 E,F
4-TR29	ET-200505	TR 2SC2603 E,F
4-TR30	ET-554657	TR 2SA733A P,Q
4-D1	ED-322238	D SILICON 1B4B41 100/1.0A
4-D2to5	ED-306109	Δ D SILICON W03B 100/1.0A
4-D6	ED-338412	D ZENER V HZ27-3S1
4-D7	ED-337019	D ZENER V HZ6A-1S1
4-D8	ED-338403	D ZENER V HZ11B-1S1
4-D9,10	ED-200468	D SILICON V DS448-VB6
4-D12	ED-337289	D ZENER V HZ5A-1S1
4-D14	ED-200468	D SILICON V DS448-VB6
4-D17,18	ED-200468	D SILICON V DS448-VB6
4-D20	ED-306109	D SILICON W03B 100/1.0A
4-D22	ED-337019	D ZENER V HZ6A-1S1
4-SW1	ES-312234	Δ SW PUSH SDL-1P 01-1 E (U,E,B,S,V)
4-SW1	ES-312235	Δ SW PUSH SDL-1P 01-1 J (J)
4-SW1	ES-312238	Δ SW PUSH SDL-1P 01-1 UC (C,A)
4-VR1	EV-464220	R S-FIX H V8K4-1 3P 503
4-VS1	EJ-283140	Δ SOCKET SELECTER X-I7238 6P (U)
4-CR1	EC-338341	C COMP 05-0034
4-CR2	ER-337374	R COMP 01-0400
4-CR3	ER-337376	R COMP 01-0399
4-CR4	ER-337631	R COMP 01-0449
4-X1	EC-337017	OSC CE CSB800A 0.8MHZ
4-FR2	ER-337287	Δ R FUSE ERD2FC 1/4W 20R0G
4-R5	ER-337283	R MF V 1/4W 3901G
4-R6	ER-337284	R MF V 1/4W 1202G
4-R7,8	ER-325270	R OMF H FS 1W 272J
4-R22	ER-313699	R OMF H FS 2W 221J
4-R55	ER-338231	R MF V 1/4W 5361F
4-R56	ER-338232	R MF V 1/4W 2871F
4-R57	ER-338233	R MF V 1/4W 2261F
4-R58	ER-338234	R MF V 1/4W 1331F
4-R59	ER-338235	R MF V 1/4W 1820F
4-C4	EC-306986	C STY V F05 500 221K 50DC
4-C8	EC-338396	Δ C MMY V ECQEW 473M 250AC (U)
4-C8	EC-338400	Δ C MMY V ECQ-E 473M 125DC (J)
4-C8	EC-338419	Δ C MMY V ECQUE 473JM 125AC (C,A)
4-C8	EC-331410	Δ C MMY V ECQUF 473M 250AC (E,B,S,V)

REF. No.	PARTS NO.	DESCRIPTION
		SW P.C BOARD
4-SW1	ES-337043	SW ROTARY SRU1023 1-02-03N
4-SW2	ES-337043	SW ROTARY SRU1023 1-02-03N
4-J1	EJ-337654	DIN J UC-0044 P 8P

5. METER/OPERATE P.C BOARD BLOCK

REF. NO.	PARTS NO.	DESCRIPTION
5-IC1,2	EI-315799	IC HA12019
5-IC3	EI-337013	IC LB1290
5-D1	ED-200469	D SILICON H DS448 FA5 F10
5-D2	ED-337014	D LED SR503D RED
5-D3	ED-200469	D SILICON H DS448 FA5 F10
5-D4	ED-337016	D LED SG203DA GRN
5-IN1	EM-336988	IND FL FIP48BW11Y DOUBLE
5-SW1to9	ES-336780	SW TACT KHH10902

6. MOTOR P.C BOARD BLOCK

REF. NO.	PARTS NO.	DESCRIPTION
6-IC1,2	EI-201940	IC NJM4558S
6-IC3,4	EI-337568	HOLE ELEMENT DHD-H070
6-TR1	ET-337011	TR 2SC2274K D,E
6-TR2	ET-337012	TR 2SA984K D,E
6-TR3	ET-337011	TR 2SC2274K D,E
6-TR4	ET-337012	TR 2SA984K D,E
6-D1to4	ED-316143	D SILICON H 1S2473HS F10
6-D5	ED-338561	D ZENER H HZ2 F10 B2
6-VR1,2	EV-464253	R S-FIX V V8K1-1 3P 202

ASSEMBLY BLOCK

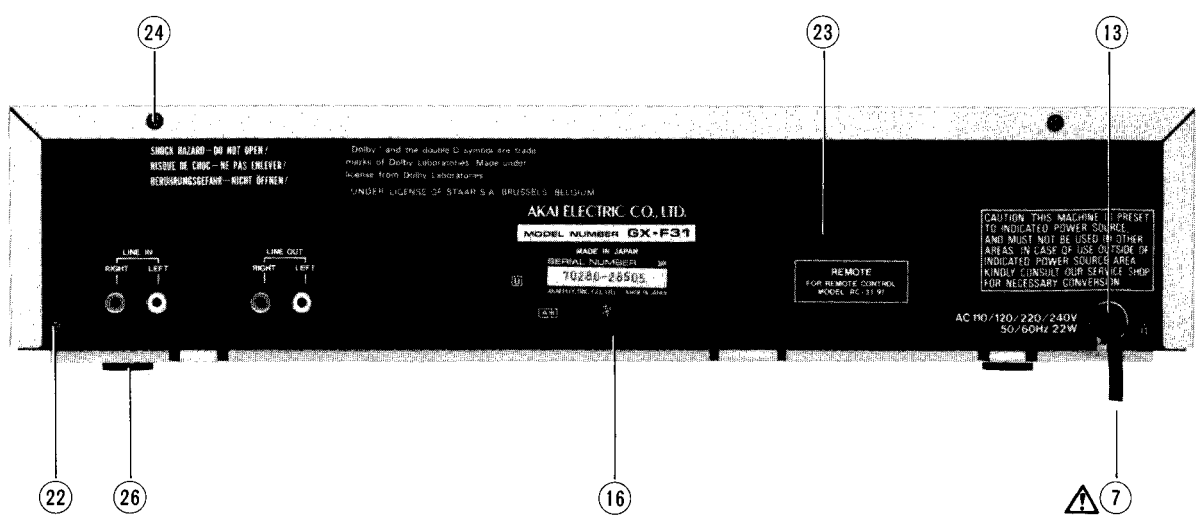
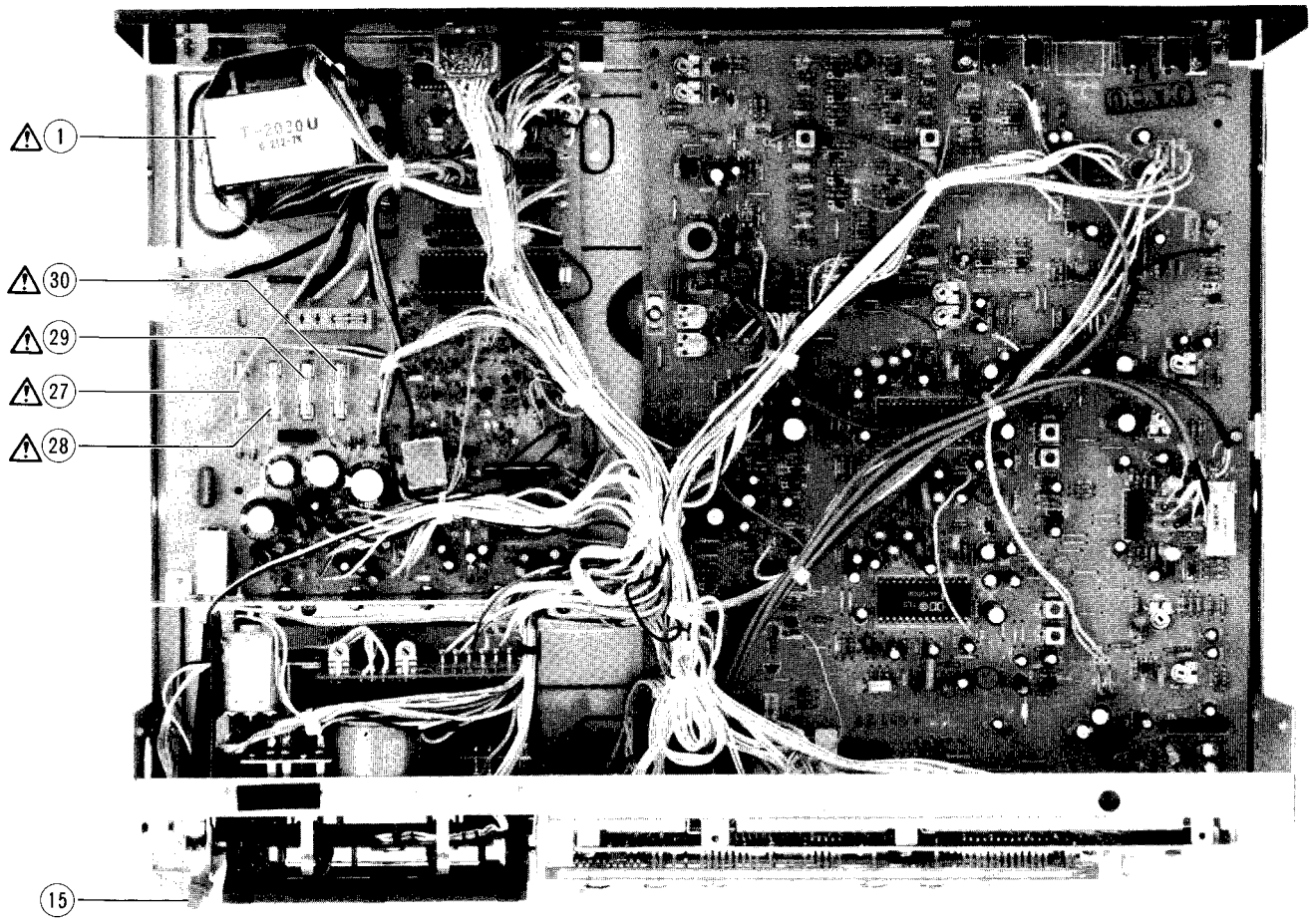

7. ASSEMBLY BLOCK

REF. NO.	PARTS NO.	DESCRIPTION
7-1	BT-337244	△ TRANS POWER T-2030(U)
7-2x	BT-337245	△ TRANS POWER T-2030(J)
7-3x	BT-337246	△ TRANS POWER T-2030(A,C)
7-4x	BT-337247	△ TRANS POWER T-2030(E,V)
7-5x	BT-337248	△ TRANS POWER T-2030(B,S)
7-6x	ZS-301398	ST BID40x08STL CMT
7-7	EW-306428	△ AC CORD 2 CORES KP-205A, VFF J (U)
7-8x	EW-306427	△ AC CORD 2 CORES KP-211, VFF J (J)
7-9x	EW-305691	△ AC CORD 2 CORES KP-8, SPT-1 UC (C,A)
7-10x	EW-313882	△ AC CORD 2 CORES KP-419C, LTCE-2F E (E,V)
7-11x	EW-313884	△ AC CORD 2 CORES GTBS-2F 24/0.20x2 B (B)
7-12x	EW-201515	△ AC CORD 2 CORES KP-560, LTSA-2F S (S)
7-13	SZ-631945	STRAIN RELIEF SR-4N-4 (U,J,C,A,E,S,V)
7-14x	EJ-692908	STRAIN RELIEF SR-5N-4 (B)
7-15	EL-337053	PL CORD 16.0V 80MA 400/400
7-16	SP-336190F	PANEL REAR GX-F31 (U) AS
7-17x	SP-336190G	PANEL REAR GX-F31 (J) AS
7-18x	SP-336190H	PANEL REAR GX-F31 (C) AS
7-19x	SP-336190M	PANEL REAR GX-F31 (A) AS
7-20x	SP-336190J	PANEL REAR GX-F31 (E,V) AS
7-21x	SP-336190K	PANEL REAR GX-F31 (B,S) AS
7-22	ZS-463353	T2BR30x08STL BNI
7-23	ZW-231030	RV NYL30x045 BL
7-24	ZS-463353	T2BR30x08STL BNI
7-25x	ZW305013	RV POP32
7-26	SA-336217	FOOT
7-27	EF-327103	△ FUSE TSC A 250V 0.50A (F2)(U,J)
7-28	EF-327103	△ FUSE TSC A 250V 0.50A (F3)(U,J)
7-29	EF-306949	△ FUSE TSC A 250V 1.25A (F4)(U,J)
7-30	EF-306949	△ FUSE TSC A 250V 1.25A (F5)(U,J)
7-31x	EF-309390	△ FUSE TSC 125V 0.50A (F2)(C,A)
7-32x	EF-309390	△ FUSE TSC 125V 0.50A (F3)(C,A)
7-33x	EF-309392	△ FUSE TSC 125V 1.25A (F4)(C,A)
7-34x	EF-309392	△ FUSE TSC 125V 1.25A (F5)(C,A)
7-35x	EF-330462	△ FUSE GGS A 250V 0.20A (F6)(C,A)
7-36x	EF-623103	△ FUSE SEMKO T 250V 1A(F1)(B)
7-37x	EF-593706	△ FUSE SEMKO T 250V 0.50A (F2)(E,B,S,V)
7-38x	EF-593706	△ FUSE SEMKO T 250V 0.50A (F3)(E,B,S,V)
7-39x	EF-602550	△ FUSE SEMKO T 250V 1.25A (F4)(E,B,S,V)
7-40x	EF-602550	△ FUSE SEMKO T 250V 1.25A (F5)(E,B,S,V)
7-41x	EF-300588	△ FUSE EAWK T 250V 0.20A (F6) (E,B,S,V)

FINAL ASSEMBLY BLOCK

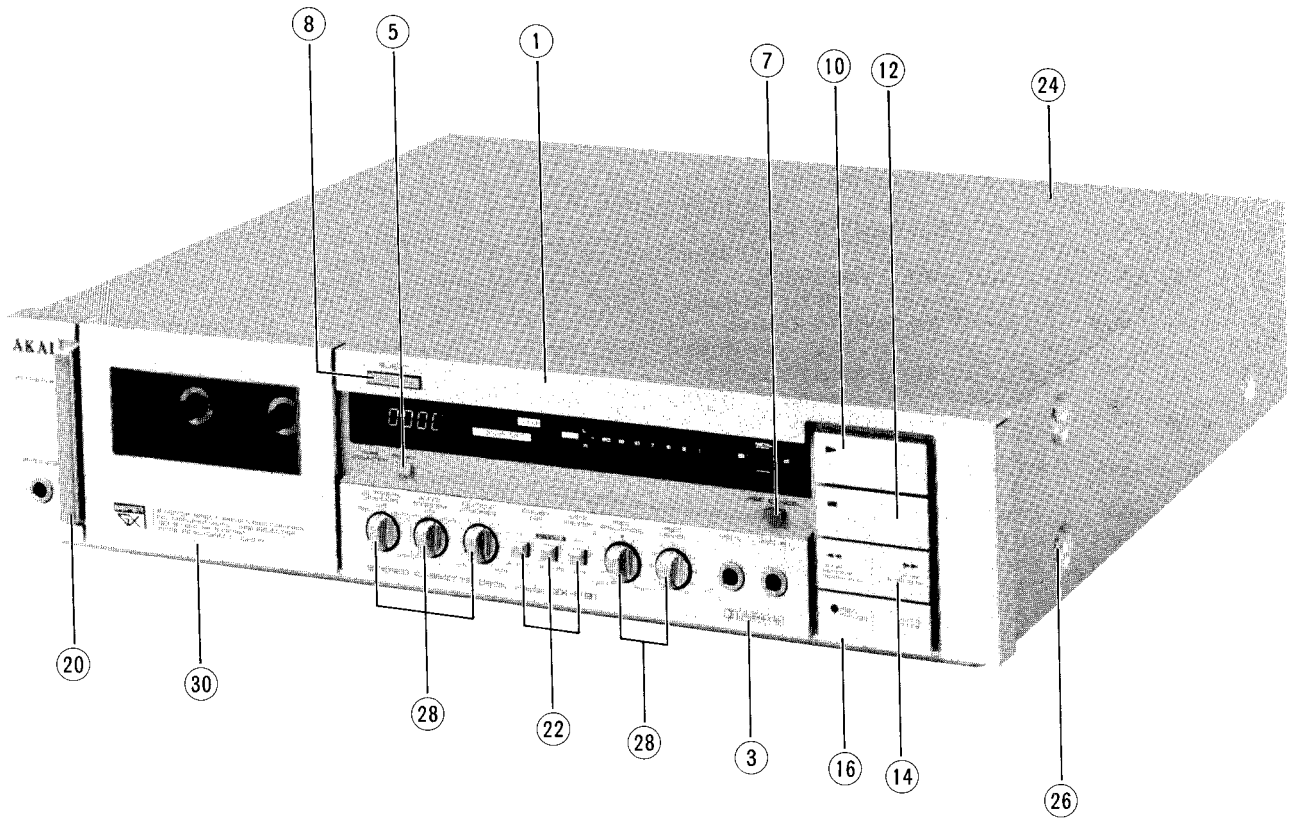

8. FINAL ASSEMBLY BLOCK

REF. NO.	PARTS NO.	DESCRIPTION
FRONT PANEL BLOCK		
8-1	SP-336188C	PANEL FRONT GX-F31
8-2x	SP-336188D	PANEL FRONT GX-F31-P
8-3	BD-B336134A	PANEL SUB (D) PART
8-4x	BD-B336134B	PANEL SUB (D)-P PART
8-5	SK-336237A	KNOB (A-1)
8-6x	SK-336237C	KNOB (A)-P
8-7	SK-336237B	KNOB (A-2)
8-8	SK-336240A	KNOB (C)
8-9x	SK-336240B	KNOB (C)-P
8-10	SK-B336241A	KNOB OPERATE (A) PART
8-11x	SK-B336241B	KNOB OPERATE (A)-P PART
8-12	SK-B336242A	KNOB OPERATE (B) PART
8-13x	SK-B336242B	KNOB OPERATE (B)-P PART
8-14	SK-B336243C	KNOB OPERATE (C-2) PART
8-15x	SK-B336243D	KNOB OPERATE (C-2)-P PART
8-16	SK-B336244A	KNOB OPERATE (D) PART
8-17	BD-B336244B	KNOB OPERATE (D)-P PART
8-18x	SP-336236A	PANEL SUB (B-1)
8-19x	SP-336236B	PANEL SUB (B-1)-P
8-20	SK-336251	KNOB POWER
8-21x	SK-336252	KNOB SPACER
FINAL ASSEMBLY BLOCK		
8-22	SK-336230A	KNOB PUSH
8-23x	SK-336230B	KNOB PUSH-P
8-24	SP-336191A	COVER UPPER
8-25x	SP-336191B	COVER UPPER-P
8-26	ZS-341959	ST BID40x06STL NI3
8-27x	ZS-341960	ST BID40x06STL BNI
8-28	SK-336229A	KNOB ROTARY
8-29x	SK-336229B	KNOB ROTARY-P
8-30	BD-B336235A	LID PANEL PART
8-31x	BD-B336235B	LID PANEL-P PART

When ordering parts, please quote Parts Number, Description and Model Number.

II. MODEL GX-F51

RECOMMENDED SPARE PARTS

Because, if the parts listed below are on hand, almost any repair can be accomplished, we suggest that you stock these Recommended Spare Parts Items.

NO.	PARTS NO.	DESCRIPTION	NO.	PARTS NO.	DESCRIPTION
1	ET-337359	PHOTO SENSOR MCD-7213P	68	EF-593706	△ FUSE SEMKO T 250V 0.50A (E,B,S,V)(F3)
2	ET-311977	PHOTO SENSOR SPI-201	69	EF-602550	△ FUSE SEMKO T 250V 1.25A (E,B,S,V)(F4,5)
3	ET-321016	TR FET 2SK117 GR,BL	70	EF-623103	△ FUSE SEMKO T 250V 1A(B)(F1)
4	ET-200558	TR 2SA1115 E,F	71	EF-327103	△ FUSE TSC A 250V 0.50A(U,J)(F3)
5	ET-554657	TR 2SA733A P,Q	72	EF-306949	△ FUSE TSC A 250V 1.25A (U,J)(F4,5)
6	ET-337012	TR 2SA984K D,E	73	EF-309390	△ FUSE TSC 125V 0.50A(C,A)(F3)
7	ET-322598	TR 2SB632K E,F	74	EF-309392	△ FUSE TSC 125V 1.25A(C,A)(F4,5)
8	ET-328438	TR 2SB808-V F,G	75	EI-337568	HOLE ELEMENT DHD-H070
9	ET-336997	TR 2SB808-V G,H	76	EI-330352	IC BA6109
10	ET-308976	TR 2SC1815 BL,GR	77	EI-315799	IC HA12019
11	ET-337258	TR 2SC1843 E,F	78	EI-336983	IC HA12038
12	ET-331279	TR 2SC1843 P,F SNP	79	EI-336761	IC LA6458S
13	ET-309353	TR 2SC2274 E,F	80	EI-337013	IC LB1290
14	ET-337011	TR 2SC2274K D,E	81	EI-337009	IC LC4049
15	ET-310833	TR 2SC2274K E	82	EI-337008	IC LC7800
16	ET-200505	TR 2SC2603 E,F	83	EI-337006	IC LM6402H-063
17	ET-316171	TR 2SC536K-NP E,F	84	EI-337369	IC MB74LS00M
18	ET-328437	TR 2SD1012-V F,G	85	EI-337242	IC MB8843-600M
19	ET-328868	TR 2SD1012-V G,H	86	EI-337228	IC M5218L0
20	ET-452531	TR 2SD313 E,F	87	EI-336994	IC M5230L
21	ET-310148	TR 2SD612K E,F	88	EI-213390	IC NJM4558D
22	ET-318239	TR 2SD863 E,F	89	EI-201940	IC NJM4558S
23	EV-315416	R S-FIX H D8 3P 103	90	EI-336995	IC NJM78L05A
24	EV-321637	R S-FIX H D8 3P 104	91	EI-200938	IC TA75558S
25	EV-315414	R S-FIX H D8 3P 203	92	EI-302233	IC TC4051BP
26	EV-315412	R S-FIX H D8 3P 502	93	EI-336992	IC μPC1043
27	EV-315413	R S-FIX H D8 3P 503	94	EI-338392	IC μPC1224H
28	EV-336785	R S-FIX H TM8KV2-1S 3P 0.50W 104	95	EJ-283140	△ SOCKET SELECTER X-17238 6P (U)
29	BF-B336013	FLYWHEEL PART	96	EJ-337654	DIN J UC-0044 P 8P
30	BH-T2030A190A	HEAD BLK GX-F51	97	EL-337053	PL CORD 16.0V 80MA 400/400
31	BL-B336150	ARM PINCH ROLLER (A) PART	98	EM-337243	IND FL FIP48AW11Y DOUBLE
32	BM-M3103A010A	△ MOTOR BLM-300	99	EO-337044	COIL FIX 2 102AK-005 36MH
33	BM-B337064	△ MOTOR OPERATION (PULLEY) PART	100	EO-337046	COIL OSC 1 0365-028 100KHZ
34	BM-B336989	△ REEL MOTOR (PULLEY) PART	101	EO-315758	COIL TUN 1 100S-431 100KHZ
35	BM-T2030A120A	REEL MOTOR BLK GX-F51	102	EO-337055	COIL VARI 1 FE002S 10MH
36	BR-336606	REEL TABLE ASSY	103	EP-322437	RELAY LEAD LAB2NS 2NO 5V
37	BT-337246	△ TRANS POWER T-2030(A,C)	104	ER-337287	△ R FUSE ERD2FC 1/4W 20ROG
38	BT-337248	△ TRANS POWER T-2030(B,S)	105	ER-337286	△ R FUSE ERD2FC 1/4W 30ROG
39	BT-337247	△ TRANS POWER T-2030(E,V)	106	ER-307565	△ R FUSE ERD2FC 1/4W 6R8J
40	BT-337245	△ TRANS POWER T-2030(J)	107	ER-337380	FILTER CE KMFC-1001S 3.580MHZ
41	BT-337244	△ TRANS POWER T-2030(U)	108	ER-336775	FILTER DB D07001K 19KHZ
42	BZ-T2030A110A	OIL CLUTCH BLK GX-F51	109	ER-336776	FILTER DB D07003K 100KHZ
43	EC-338341	C COMP 05-0034	110	ER-337376	R COMP 01-0399
44	EC-337017	OSC CE CSB800A 0.8MHZ	111	ER-337374	R COMP 01-0400
45	ED-328605	D GERMA H 1S188FM-1-LH SNP	112	ER-337631	R COMP 01-0449
46	ED-308952	D GERMA V 1K34A-LR F07	113	ES-312234	△ SW PUSH SDL-1P 01-1 E (U,E,B,S,V)
47	ED-337016	D LED SG203DA GRN	114	ES-312235	△ SW PUSH SDL-1P 01-1 J (J)
48	ED-337010	D LED SLF-201C GRN	115	ES-312238	△ SW PUSH SDL-1P 01-1 UC (C,A)
49	ED-337014	D LED SR503D RED	116	ES-336990	SW LEAF BSW-169 01-1 NO
50	ED-301911	D SILICON H DS448	117	ES-337344	SW MICRO SS-01-ED UC
51	ED-200469	D SILICON H DS448 FA5 F10	118	ES-337045	SW PUSH SUN312A 3-THROW
52	ED-316143	D SILICON H 1S2473HS F10	119	ES-337232	SW ROTARY SBM1023N 2-02-03N
53	ED-200468	D SILICON V DS448-VB6	120	ES-337231	SW ROTARY SBM1024N 2-02-04N
54	ED-306109	D SILICON W03B 100/1.0A	121	ES-336780	SW TACT KHH10902
55	ED-322238	D SILICON 1B4B41 100/1.0A	122	EV-464220	R S-FIX H V8K4-1 3P 503
56	ED-338092	D ZENER H HZ-2 B1	123	EV-522663	R S-FIX V V8K1-1 3P 104
57	ED-338561	D ZENER H HZ2 F10 B2	124	EV-464253	R S-FIX V V8K1-1 3P 202
58	ED-337292	D ZENER H HZ5 B1	125	EV-464264	R S-FIX V V8K1-1 3P 503
59	ED-309069	D ZENER H HZ6 B2	126	EV-337052	VR ROTARY 16L10xOR B103
60	ED-338403	D ZENER V HZ11B-1S1	127	EV-337028	VR ROTARY 16P20x20 A204
61	ED-338413	D ZENER V HZ24-2S1	128	EV-337029	VR ROTARY 16P20x2P M204 N204
62	ED-338412	D ZENER V HZ27-3S1	129	EV-337030	VR ROTARY 16P20x2Q B103
63	ED-337289	D ZENER V HZ5A-1S1	130	HE-337047	HEAD E HJ213270 C
64	ED-337019	D ZENER V HZ6A-1S1	131	HP-H2201A010A	HEAD R/P PR4-7 C
65	ED-336998	D ZENER V HZ6B-2S1	132	MB-336021	BELT OPERATION
66	EF-300588	△ FUSE EAWK T 250V 0.20A (E,B,S,V)(F6)	133	MP-336153	PINCH ROLLER (A)
67	EF-330462	△ FUSE GGS A 250V 0.20A (C,A)(F6)	134	TC-336002	HOLDER CAPSTAN (B)
			135	TC-336004B	HOLDER CAPSTAN (C-2)
			136	TC-336605	WIND IDLER ASSY

When ordering parts, please quote Parts Number, Description and Model Number.

MECHA BLOCK

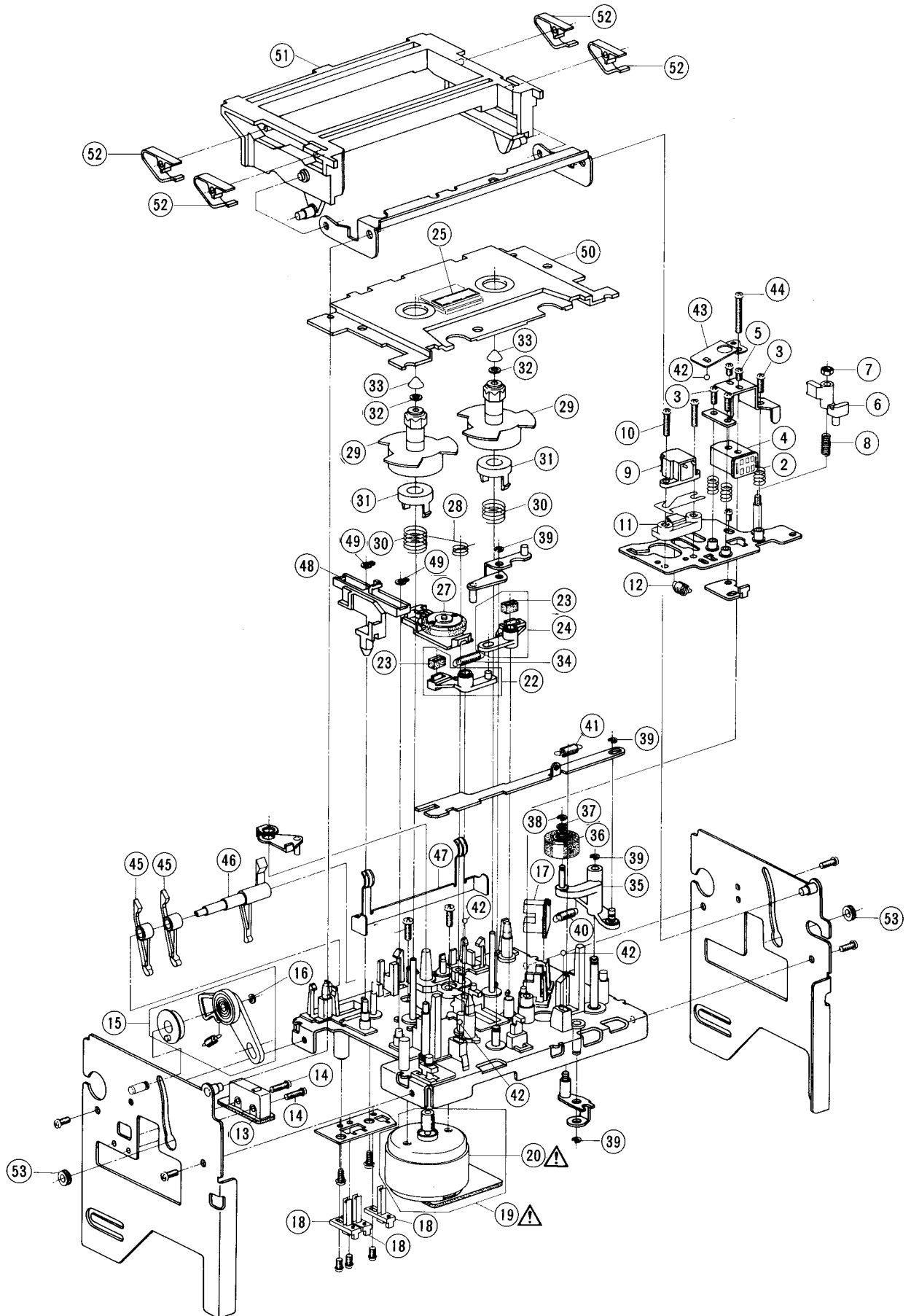

1. MECHA BLOCK

REF. NO.	PARTS NO.	DESCRIPTION
HEAD BLOCK		
1-1x	BH-T2030A190A	HEAD BLK GX-F51
1-2	ZG-336127	SP PUSH HEAD
1-3	ZS-608106	PAN20x06STL CMT
1-4	HP-H2201A010A	HEAD R/P PR4-7 C
1-5	ZS-477876	PAN20x03STL CMT
1-6	HZ-336129	GUIDE TAPE
1-7	ZW-618884	N20STL CMT 1
1-8	ZG-336130	SP PUSH GUIDE
1-9	HE-337047	HEAD E HJ213270 C
1-10	ZS-465298	PAN23x10STL CMT
1-11	HZ-336131	HOLDER E HEAD
1-12	ZG-341972	SP PULL HEAD RETURN
SW MICRO P.C BOARD BLOCK		
1-13	ES-337344	SW MICRO SS-01-ED UC (SW1)
CHASSIS MECHA SIDE (L) BLOCK		
1-14	ZS-310337	PAN20x08STL CMT
1-15	BZ-T2030A110A	OIL CLUTCH BLK GX-F51
1-16	ZW-270088	RING E 190SUP CMT
DETECTION P.C BOARD BLOCK		
1-17	ET-311977	PHOTO SENSOR SPI-201 (PH1)
SW LEAF BLOCK		
1-18	ES-336990	SW LEAF BSW-169 01-1 NO (SW902.903,904)
REEL MOTOR BLOCK		
1-19	BM-T2030A120A	REEL MOTOR BLK GX-F51
1-20	BM-B336989	△ REEL MOTOR (PULLEY) PART
1-21x	EO-669273	COIL FIX 2 FL5R200 18μH (L1,2)
LEVER BRAKE (A) BLOCK		
1-22	BL-T2030A160A	LEVER BRAKE (A) BLK GX-F51
1-23	TC-336146	BRAKE RUBBER
LEVER BRAKE (B) BLOCK		
1-24	BL-T2030A170A	LEVER BRAKE (B) BLK GX-F51
D LED BLOCK		
1-25	ED-337010	D LED SLF-201C GRN (D901)
MECHA BLOCK		
1-26x	BZ-T2030A080A	MECHA BLK GX-F51
1-27	TC-336605	WIND IDLER ASSY
1-28	ZG-336140	SP TORSION IDLER
1-29	BR-336606	REEL TABLE ASSY
1-30	ZG-336141	SP PUSH BT
1-31	TC-336142	HOLDER BT SP
1-32	ZW-330073	PW21x040x020
1-33	MT-305793	REEL CAP
1-34	ZG-312946	SP T1-3.2/0.29-16.0 T1-062
1-35	BL-B336150	ARM PINCH ROLLER (A) PART
1-36	MP-336153	PINCH ROLLER (A)
1-37	ZW-381644	PW21x040x013PSL
1-38	ZW-356657	RING E 150SUP CMT
1-39	ZW-270088	RING E 190SUP CMT
1-40	ZG-342575	SP PULL PINCH ROLLER (T-2)
1-41	ZG-321534	SP T2-3.2/0.29-12.5 T2-060
1-42	MV-357208	BALL200STL
1-43	ZG-336157	SP PLATE HEAD HOLD
1-44	ZS-342002	ST PAN26x16STL CMT
1-45	ML-336158	LEVER DETECTION (B)
1-46	ML-336159	LEVER DETECTION (A)
1-47	ZG-336160	SP PLATE CASSETTE HOLDER (A)
1-48	TC-336161	SLIDE EJECT
1-49	ZW-336603	RING GRIP 285SUP ACP
1-50	BD-B336162B	LID DECORATION (B) PART
1-51	SP-336163	LID CASE
1-52	ZG-336615	SP PLATE CASSETTE HOLDER (B)
1-53	SZ-336166	COLLAR LID

MOTOR BLOCK

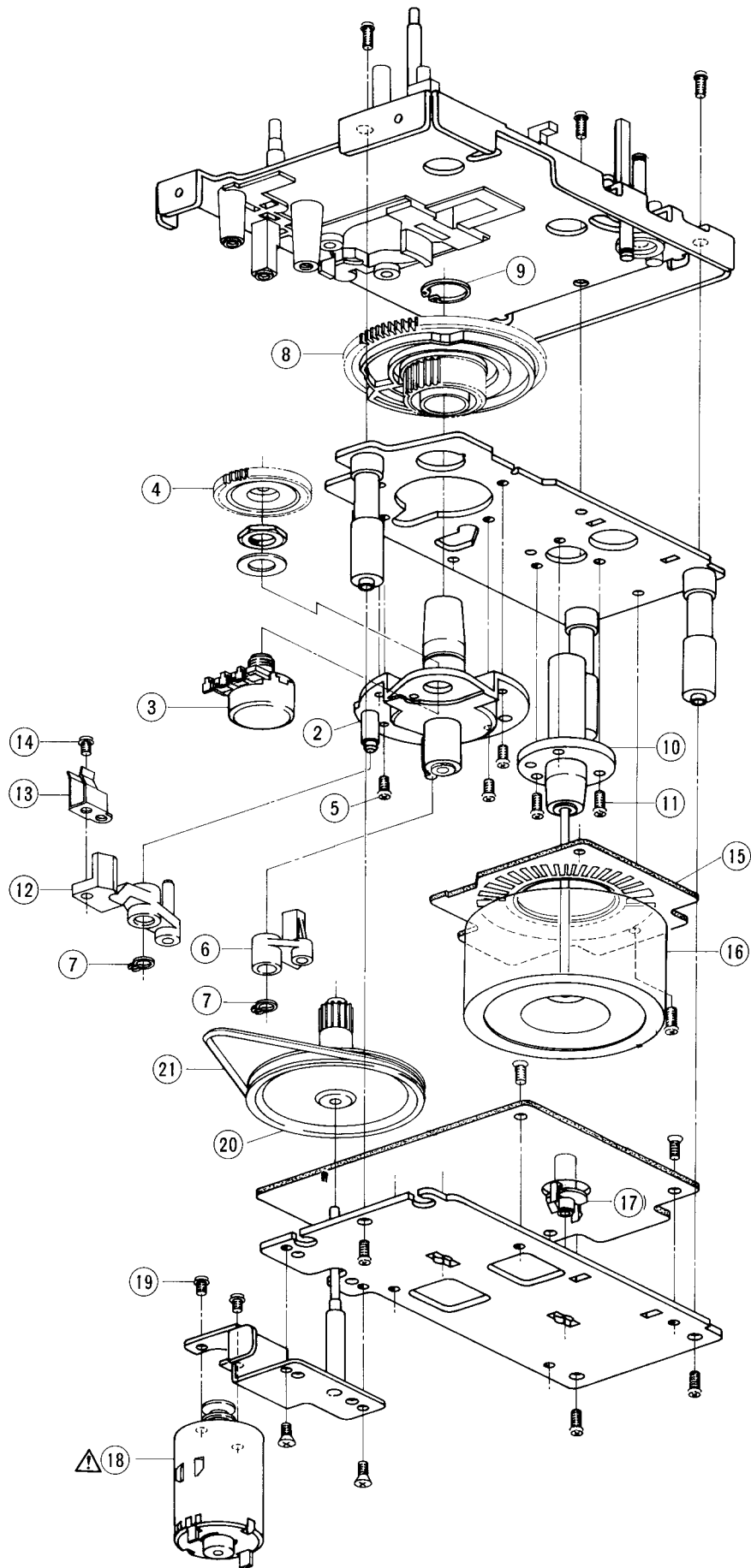

2. MOTOR BLOCK

REF. NO.	PARTS NO.	DESCRIPTION
2-1x	BM-M3103A010A	MOTOR BLM-300
2-2	TC-336004B	HOLDER CAPSTAN (C-2)
2-3	EV-337052	VR ROTARY 16L10×OR B103
2-4	MZ-336005	GEAR POTENTION
2-5	ZS-432843	PAN26×04STL CMT
2-6	BL-B336007	LEVER BRAKE CAM PART
2-7	ZW-336603	RING GRIP 285SUP ACP
2-8	MZ-336006	CAM WHEEL
2-9	ZW-336604	RING S839SUP ACP
2-10	TC-336002	HOLDER CAPSTAN (B)
2-11	ZS-479474	PAN26×05STL CMT
2-12	BL-B336009	LEVER EJECT CAM PART
2-13	ZG-336011	SP PLATE CAM LEVER
2-14	ZS-477876	PAN20×03STL CMT
2-15	EA-336012	PC FG
2-16	BF-B336013	FLYWHEEL PART
2-17	TC-336016	HOLDER THRUST (A)
2-18	BM-B337064	MOTOR OPERATION (PULLEY) PART)
2-19	ZS-477876	PAN20×03STL CMT
2-20	MR-336019	PULLEY OPERATE
2-21	MB-336021	BELT OPERATION

3. PRE AMP P.C BOARD BLOCK

REF. NO.	PARTS NO.	DESCRIPTION	REF. NO.	PARTS NO.	DESCRIPTION
3-1	BA-T2030A030A	PC PRE AMP BLK GX-F51 (U) (U,J,C,A)	3-FL3	ER-336776	FILTER DB D07003K 100KHZ
3-2	BA-T2030A030B	PC PRE AMP BLK GX-F51 (E) (E,B,S,V)	3-FL4	ER-336775	FILTER DB D07001K 19KHZ
3-3	BA-T2030A030C	PC PRE AMP BLK GX-F51-P (U) (U,J,C,A)	3-FL5,6	EO-315758	COIL TUN 1 100S-431 100KHZ
3-4	BA-T2030A030D	PC PRE AMP BLK GX-F51-P (E) (E,B,S,V)	3-T1	EO-337046	COIL OSC 1 0365-028 100KHZ
			3-FR1,2	ER-307565	Δ R FUSE ERD2FC 1/4W 6R8J
			3-C4	EC-313532	C EC V F05 NP 04D 1R0M 50DC
			3-C45	EC-329431	C SA V T05 1R0K 25DC
			3-C49,50	EC-308940	C EC V F05 NP 04D R47M 50DC
			3-C63	EC-331631	C STY V SNP CQFS 821J 50DC
			3-C65	EC-338042	C EC V F05 NP NXA 2R2M 50DC
			3-C75	EC-314992	C STY V F05 CQF09 681J 50DC
			3-C77	EC-332052	C EC V F05 NP SM 4R7M 35DC
			3-C83	EC-333972	C EC V F05 NP SM 3R3M 50DC
			3-C95	EC-337005	C PP V F10 ECQ-F 152J 630DC
			3-C116	EC-306017	C STY V F05 CQ09S 221J 50DC
					PHONE JACK P.C BOARD
			3-J3	EJ-336885	PHONE J 3P HLJ0607-023 6.3 (U,J,C,A)
			3-J3	EJ-336886	PHONE J 3P HLJ0607-020 6.3 (E,B,S,V)
					PRE AMP P.C BOARD
3-IC1	EI-200938	IC TA75558S			
3-IC2	EI-336983	IC HA12038			
3-IC3	EI-337228	IC M5218L0			
3-IC4	EI-336761	IC LA6458S			
3-IC5	EI-337369	IC MB74LS00M			
3-IC6	EI-338392	IC μPC1224H			
3-IC7to9	EI-336761	IC LA6458S			
3-TR1	ET-328868	TR 2SD1012-V G,H			
3-TR2to6	ET-200505	TR 2SC2603 E,F			
3-TR7,8	ET-200558	TR 2SA1115 E,F			
3-TR9to16	ET-200505	TR 2SC2603 E,F			
3-TR17	ET-328868	TR 2SD1012-V G,H			
3-TR18	ET-337258	TR 2SC1843 E,F			
3-TR19to21	ET-328868	TR 2SD1012-V G,H			
3-TR22to29	ET-200505	TR 2SC2603 E,F			
3-TR30	ET-200558	TR 2SA1115 E,F			
3-TR31	ET-200505	TR 2SC2603 E,F			
3-TR32	ET-322598	TR 2SB632K E,F			
3-TR33	ET-331279	TR 2SC1843 P,F SNP			
3-TR34	ET-200505	TR 2SC2603 E,F			
3-TR35,36	ET-310833	TR 2SC2274K E			
3-TR37	ET-309353	TR 2SC2274 E,F			
3-TR38	ET-321016	TR FET 2SK117 GR,BL			
3-TR41	ET-200505	TR 2SC2603 E,F			
3-TR42	ET-328437	TR 2SD1012-V F,G			
3-TR43	ET-328438	TR 2SB808-V F,G			
3-TR44	ET-200505	TR 2SC2603 E,F			
3-D1	ED-301911	D SILICON H DS448			
3-D2	ED-337292	D ZENER H HZ5 B1			
3-D3	ED-328605	D GERMA H 1S188FM-1-LH SNP			
3-D4to13	ED-301911	D SILICON H DS448			
3-D14	ED-200468	D SILICON V DS448-VB6			
3-D15to17	ED-301911	D SILICON H DS448			
3-D18	ED-309069	D ZENER H HZ6 B2			
3-D19,20	ED-301911	D SILICON H DS448			
3-D21,22	ED-200468	D SILICON V DS448-VB6			
3-D23,24	ED-308952	D GERMA V 1K34A-LR F07			
3-D25	ED-338413	D ZENER V HZ24-2S1			
3-D26	ED-301911	D SILICON H DS448			
3-J1	EJ-337027	PHONE J THROW HLJ4353-210 2x3P			
3-J1	EJ-337024	PHONE J THROW HLJ4353-010 2x3P (P)			
3-J2	EJ-332435	PIN J P 4P (U,J,C,A)			
3-J2	EJ-332437	JACK PLATE (E,B,S,V)			
3-SW1to3	ES-337045	SW PUSH SUN312A 3-THROW			
3-VR1	EV-337029	VR ROTARY 16P20x2P M204 N204			
3-VR2	EV-337028	VR ROTARY 16P20x2O A204			
3-VR3	EV-337030	VR ROTARY 16P20x2Q B103			
3-VR4	EV-315414	R S-FIX H D8 3P 203			
3-VR5	EV-315413	R S-FIX H D8 3P 503			
3-VR6	EV-315416	R S-FIX H D8 3P 103			
3-VR7	EV-315414	R S-FIX H D8 3P 203			
3-VR8	EV-321637	R S-FIX H D8 3P 104			
3-VR9	EV-315412	R S-FIX H D8 3P 502			
3-VR10	EV-315416	R S-FIX H D8 3P 103			
3-VR11	EV-336785	R S-FIX H TM8KV2-1S 3P 0.50W 104			
3-L1	EO-669273	COIL FIX 2 FL5R200 18μH			
3-RL1	EP-322437	RELAY LEAD LAB2NS 2NO 5V			
3-PH1	ET-337359	PHOTO SENSOR MCD-7213P			
3-FL1	EO-337044	COIL FIX 2 102AK-005 36MH			
3-FL2	EO-337055	COIL VARI 1 FE002S 10MH			

When ordering parts, please quote Parts Number, Description and Model Number.

4. SYS. CON. P.C BOARD BLOCK

REF. NO.	PARTS NO.	DESCRIPTION
4-1	BA-T2030A050A	PC SYS CON BLK GX-F51(U)
4-2	BA-T2030A050B	PC SYS CON BLK GX-F51(J)
4-3	BA-T2030A050C	PC SYS CON BLK GX-F51(C) (C,A)
4-4	BA-T2030A050D	PC SYS CON BLK GX-F51(E) (E,S,V)
4-5	BA-T2030A050E	PC SYS CON BLK GX-F51(B)

SYS. CON. P.C BOARD

4-IC1	EI-337006	IC LM6402H-063
4-IC2,3	EI-337013	IC LB1290
4-IC4,5	EI-337008	IC LC7800
4-IC6	EI-337009	IC LC4049
4-IC7	EI-336761	IC LA6458S
4-IC8	EI-330352	IC BA6109
4-IC9	EI-336992	IC μ PC1043
4-IC10	EI-336994	Δ IC M5230L
4-IC11	EI-336995	Δ IC NJM78L05A
4-TR1	ET-322598	Δ TR 2SB632K E,F
4-TR2,3	ET-310148	Δ TR 2SD612K E,F
4-TR4	ET-308976	TR 2SC1815 BL,GR
4-TR5	ET-318239	Δ TR 2SD863 E,F
4-TR6	ET-322598	Δ TR 2SB632K E,F
4-TR7	ET-452531	Δ TR 2SD313 E,F
4-TR8	ET-308976	TR 2SC1815 BL,GR
4-TR9to17	ET-200505	TR 2SC2603 E,F
4-TR18to21	ET-336997	TR 2SB808-V G,H
4-TR22,23	ET-328868	TR 2SD1012-V G,H
4-TR24to27	ET-200505	TR 2SC2603 E,F
4-TR29	ET-200505	TR 2SC2603 E,F
4-TR30	ET-554657	TR 2SA733A P,Q
4-D1	ED-322238	Δ D SILICON 1B4B41 100/1.0A
4-D2to5	ED-306109	Δ D SILICON W03B 100/1.0A
4-D6	ED-338412	D ZENER V HZ27-3S1
4-D7	ED-337019	D ZENER V HZ6A-1S1
4-D8	ED-338403	D ZENER V HZ11B-1S1
4-D9,10	ED-200468	D SILICON V DS448-VB6
4-D12	ED-337289	D ZENER V HZ5A-1S1
4-D14	ED-200468	D SILICON V DS448-VB6
4-D17,18	ED-200468	D SILICON V DS448-VB6
4-D20	ED-306109	D SILICON W03B 100/1.0A
4-SW1	ES-312234	Δ SW PUSH SDL-1P 01-1 E (U,E,B,S,V)
4-SW1	ES-312235	Δ SW PUSH SDL-1P 01-1 J (J)
4-SW1	ES-312238	Δ SW PUSH SDL-1P 01-1 UC (C,A)
4-VR1	EV-464220	R S-FIX H V8K4-1 3P 503
4-VS1	EJ-283140	Δ SOCKET SELECTER X-17238 6P (U)
4-CR1	EC-338341	C COMP 05-0034
4-CR2	ER-337374	R COMP 01-0400
4-CR3	ER-337376	R COMP 01-0399
4-CR4	ER-337631	R COMP 01-0449
4-X1	EC-337017	OSC CE CSB800A 0.8MHZ
4-FR1	ER-337286	Δ R FUSE ERD2FC 1/4W 30R0G
4-FR2	ER-337287	Δ R FUSE ERD2FC 1/4W 20R0G
4-R5	ER-337283	R MF V 1/4W 3901G
4-R6	ER-337284	R MF V 1/4W 1202G
4-R7,8	ER-325270	R OMF H FS 1W 272J
4-R22	ER-313699	R OMF H FS 2W 221J
4-R55	ER-338231	R MF V 1/4W 5361F
4-R56	ER-338232	R MF V 1/4W 2871F
4-R57	ER-338233	R MF V 1/4W 2261F
4-R58	ER-338234	R MF V 1/4W 1331F
4-R59	ER-338235	R MF V 1/4W 1820F
4-C4	EC-306986	C STY V F05 500 221K 50DC
4-C8	EC-338396	Δ C MMY V ECQEW 473M 250AC (U)
4-C8	EC-338400	Δ C MMY V ECQ-E 473M 125DC (J)
4-C8	EC-338419	Δ C MMY V ECQUE 473M 125AC (C,A)
4-C8	EC-331410	Δ C MMY V ECQUF 473M 250AC (E,B,S,V)

REF. NO.	PARTS NO.	DESCRIPTION
SW P.C BOARD		
4-SW1	ES-337231	SW ROTARY SBM1024N 2-02-04N
4-SW2	ES-337232	SW ROTARY SBM1023N 2-02-03N
4-J1	EJ-337654	DIN J UC-0044 P 8P

5. TUNING P.C BOARD BLOCK

REF. NO.	PARTS NO.	DESCRIPTION
5-1	BA-T2030A040A	PC TUNING BLK GX-F51
5-IC1	EI-337242	IC MB8843-600M
5-IC2	EI-302233	IC TC4051BP
5-IC3	EI-213390	IC NJM4558D
5-TR1to6	ET-316171	TR 2SC536K-NP E,F
5-TR7to9	ET-200558	TR 2SA1115 E,F
5-TR10to18	ET-316171	TR 2SC536K-NP E,F
5-TR19,20	ET-200558	TR 2SA1115 E,F
5-TR21,22	ET-316171	TR 2SC536K-NP E,F
5-D1to3	ED-200468	D SILICON V DS448-VB6
5-D4,5	ED-336998	D ZENER V HZ6B-2S1
5-VR1,2	EV-464264	R S-FIX V V8K1-1 3P 503
5-VR3	EV-522663	R S-FIX V V8K1-1 3P 104
5-VR4	EV-464264	R S-FIX V V8K1-1 3P 503
5-FL1	ER-337380	FILTER CE KMFC-1001S 3.580MHZ
5-R12	ER-324251	R OMF H FS 1W 101J
5-R78	ER-337269	R OMF V SNP 1W 101J

6. METER/OPERATE P.C BOARD BLOCK

REF. NO.	PARTS NO.	DESCRIPTION
6-IC1,2	EI-315799	IC HA12019
6-IC3	EI-337013	IC LB1290
6-D1	ED-200469	D SILICON H DS448 FA5 F10
6-D2	ED-337014	D LED SR503D RED
6-D3	ED-200469	D SILICON H DS448 FA5 F10
6-D4	ED-337016	D LED SG203DA GRN
6-IN1	EM-337243	IND FL FIP48AW11Y DOUBLE
6-SW1to13	ES-336780	SW TACT KHH10902

7. MOTOR P.C BOARD BLOCK

REF. NO.	PARTS NO.	DESCRIPTION
7-IC1,2	EI-201940	IC NJM4558S
7-IC3,4	EI-337568	HOLE ELEMENT DHD-H070
7-TR1	ET-337011	TR 2SC2274K D,E
7-TR2	ET-337012	TR 2SA984K D,E
7-TR3	ET-337011	TR 2SC2274K D,E
7-TR4	ET-337012	TR 2SA984K D,E
7-D1to4	ED-316143	D SILICON H 1S2473HS F10
7-D5	ED-338561	D ZENER H HZ2 F10 B2
7-VR1,2	EV-464253	R S-FIX V V8K1-1 3P 202

ASSEMBLY BLOCK

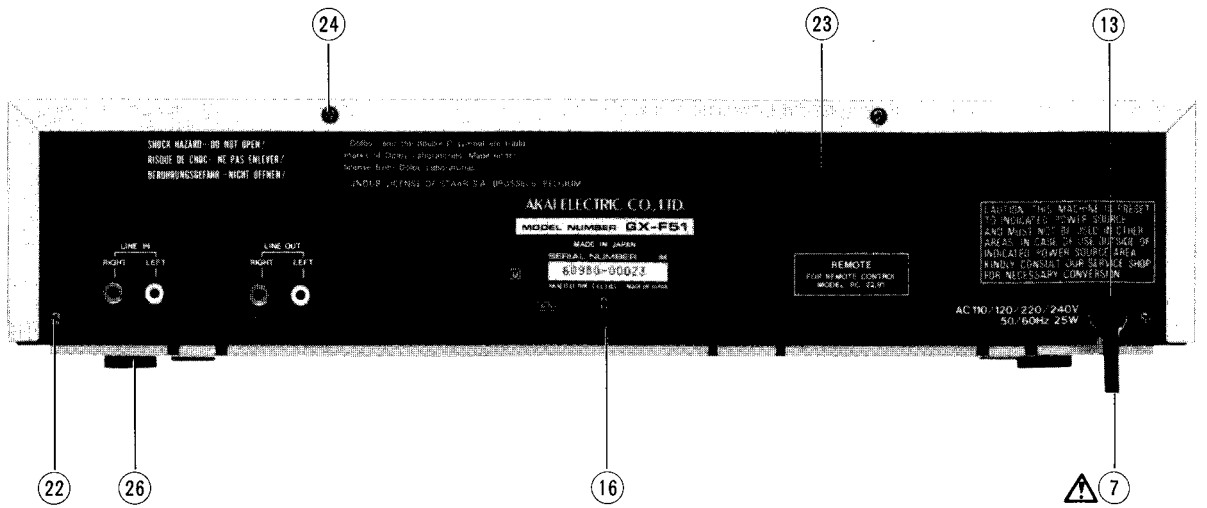
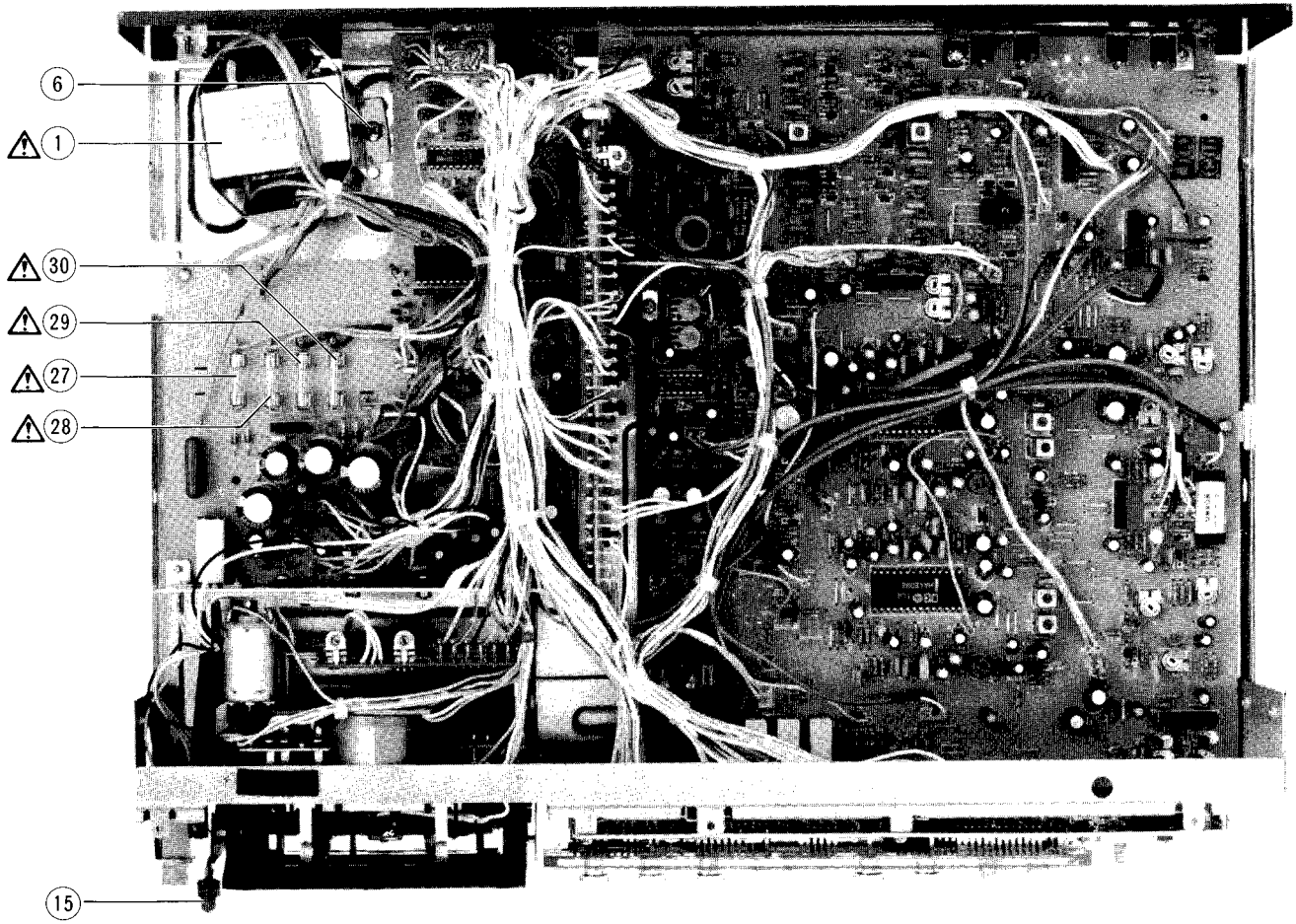

8. ASSEMBLY BLOCK

REF. NO.	PARTS NO.	DESCRIPTION
8-1	BT-337244	△ TRANS POWER T-2030(U)
8-2x	BT-337245	△ TRANS POWER T-2030(J)
8-3x	BT-337246	△ TRANS POWER T-2030(A,C)
8-4x	BT-337247	△ TRANS POWER T-2030(E,V)
8-5x	BT-337248	△ TRANS POWER T-2030(B,S)
8-6	ZS-301398	ST BID40x08STL CMT
8-7	EW-306428	△ AC CORD 2 CORES KP-205A, VFF J (U)
8-8x	EW-306427	△ AC CORD 2 CORES KP-211, VFF J (J)
8-9x	EW-305691	△ AC CORD 2 CORES KP-8, SPT-1 UC (C,A)
8-10x	EW-313882	△ AC CORD 2 CORES KP-419C, LTCE-2F E (E,V)
8-11x	EW-313884	△ AC CORD 2 CORES GTBS-2F 24/0.20x2 B (B)
8-12x	EW-201515	△ AC CORD 2 CORES KP-560, LTSA-2F S (S)
8-13	SZ-631945	STRAIN RELIEF SR-4N-4 (U,J,C,A,E,S,V)
8-14x	EJ-692908	STRAIN RELIEF SR-5N-4 (B)
8-15	EL-337053	PL CORD 16.0V 80MA 400/400
8-16	SP-336190A	PANEL REAR GX-F51(U) AS
8-17x	SP-336190B	PANEL REAR GX-F51(J) AS
8-18x	SP-336190C	PANEL REAR GX-F51(C) AS
8-19x	SP-336190L	PANEL REAR GX-F51(A) AS
8-20x	SP-336190D	PANEL REAR GX-F51(E,V) AS
8-21x	SP-336190E	PANEL REAR GX-F51(B,S) AS
8-22	ZS-463353	T2BR30x08STL BNI
8-23	ZW-231030	RV NYL30x045 BL
8-24	ZS-463353	T2BR30x08STL BNI
8-25x	ZW-305013	RV POP32 (A)
8-26	SA-336217	FOOT
8-27	EF-327103	△ FUSE TSC A 250V 0.50A (F2) (U,J)
8-28	EF-327103	△ FUSE TSC A 250V 0.50A (F3) (U,J)
8-29	EF-306949	△ FUSE TSC A 250V 1.25A (F4) (U,J)
8-30	EF-306949	△ FUSE TSC A 250V 1.25A (F5) (U,J)
8-31x	EF-309390	△ FUSE TSC 125V 0.50A (F2)(C,A)
8-32x	EF-309390	△ FUSE TSC 125V 0.50A (F3)(C,A)
8-33x	EF-309392	△ FUSE TSC 125V 1.25A (F4)(C,A)
8-34x	EF-309392	△ FUSE TSC 125V 1.25A (F5)(C,A)
8-35x	EF-330462	△ FUSE GGS A 250V 0.20A (F5) (C,A)
8-36x	EF-623103	△ FUSE SEMKO T 250V 1A(F1)(B)
8-37x	EF-593706	△ FUSE SEMKO T 250V 0.50A (F2) (E,B,S,V)
8-38x	EF-593706	△ FUSE SEMKO T 250V 0.50A (F3) (E,B,S,V)
8-39x	EF-602550	△ FUSE SEMKO T 250V 1.25A (F4) (E,B,S,V)
8-40x	EF-602550	△ FUSE SEMKO T 250V 1.25A (F5) (E,B,S,V)
8-41x	EF-300588	△ FUSE EAWK T 250V 0.20A (F6) (E,B,S,V)

FINAL ASSEMBLY BLOCK

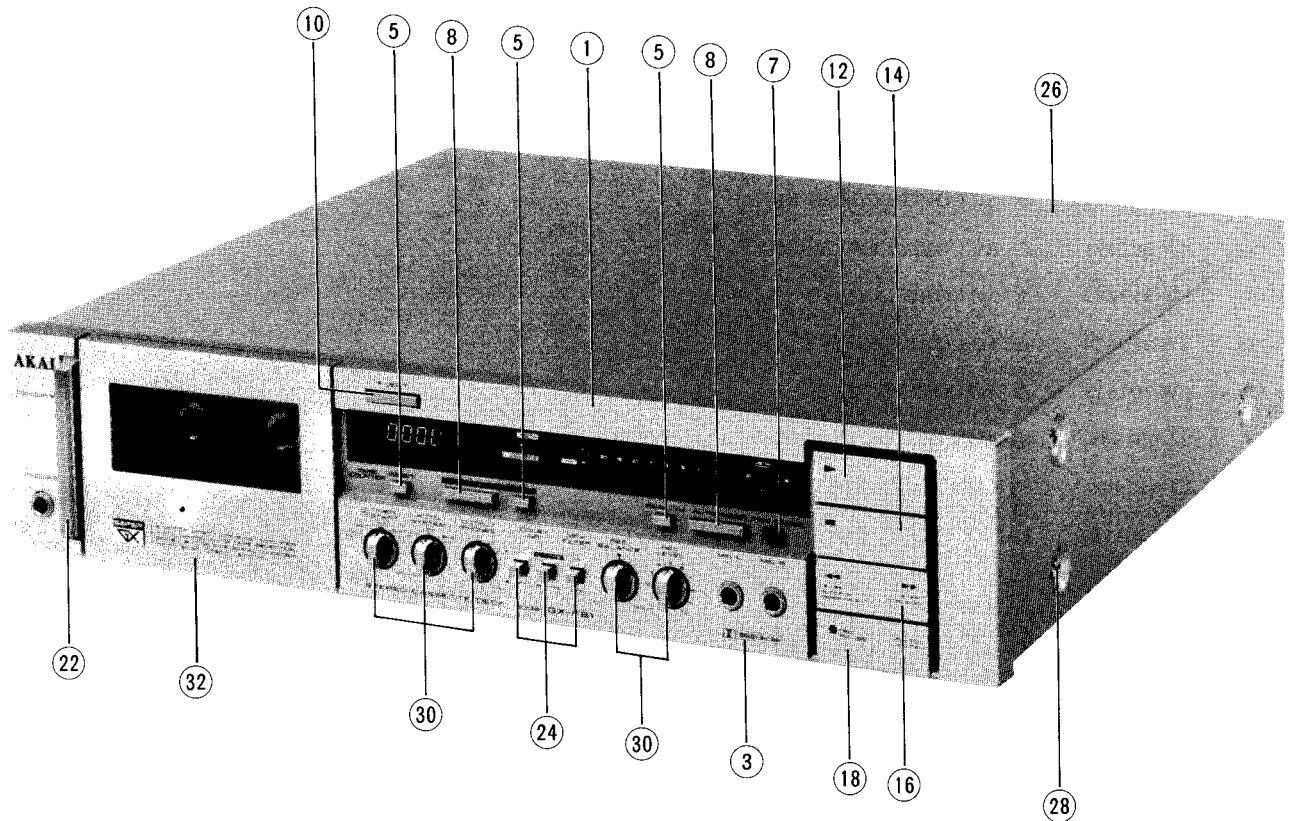

9. FINAL ASSEMBLY BLOCK

REF. NO.	PARTS NO.	DESCRIPTION
FRONT PANEL BLOCK		
9-1	BD-336188A	PANEL FRONT GX-F51
9-2x	BD-336188B	PANEL FRONT GX-F51-P
9-3	BD-B336189A	PANEL SUB (A) PART
9-4x	BD-B336189B	PANEL SUB (A)-P PART
9-5	SK-336237A	KNOB (A-1)
9-6x	SK-336237C	KNOB (A)-P
9-7	SK-336237B	KNOB (A-2)
9-8	SK-336239A	KNOB (B)
9-9x	SK-336239B	KNOB (B)-P
9-10	SK-336240A	KNOB (C)
9-11x	SK-336240B	KNOB (C)-P
9-12	SK-B336241A	KNOB OPERATE (A) PART
9-13x	SK-B336241B	KNOB OPERATE (A)-P PART
9-14	SK-B336242A	KNOB OPERATE (B) PART
9-15x	SK-B336242B	KNOB OPERATE (B)-P PART
9-16	SK-B336243C	KNOB OPERATE (C-2) PART
9-17x	SK-B336243D	KNOB OPERATE (C-2)-P PART

REF. NO.	PARTS NO.	DESCRIPTION
9-18	SK-B336244A	KNOB OPERATE (D) PART
9-19x	BD-B336244B	KNOB OPERATE (D)-P PART
9-20x	SP-336236A	PANEL SUB (B-1)
9-21x	SP-336236B	PANEL SUB (B-1)-P
9-22	SK-336251	KNOB POWER
FINAL ASSEMBLY BLOCK		
9-23x	SK-336252	KNOB SPACER
9-24	SK-336230A	KNOB PUSH
9-25x	SK-336230B	KNOB PUSH-P
9-26	SP-336191A	COVER UPPER
9-27x	SP-336191B	COVER UPPER-P
9-28	ZS-341959	ST BID40x06STL NI3
9-29x	ZS-341960	ST BID40x06STL BNI
9-30	SK-336229A	KNOB ROTARY
9-31x	SK-336229B	KNOB ROTARY-P
9-32	BD-B336235A1	LID PANEL PART
9-33x	BD-B336235B1	LID PANEL-P PART

When ordering parts, please quote Parts Number, Description and Model Number.

III. MODEL GX-F71

RECOMMENDED SPARE PARTS

Because, if the parts listed below are on hand, almost any repair can be accomplished, we suggest that you stock these Recommended Spare Parts Items.

NO.	PARTS NO.	DESCRIPTION	NO.	PARTS NO.	DESCRIPTION	NO.	PARTS NO.	DESCRIPTION
1	BH-T2032A080A	HEAD BLK GX-F71	64	EI-336994	IC M5230L	133	EV-464253	R S-FIX V V8K1-1 3P 202
2	BL-B336150	ARM PINCH ROLLER (A) PART	65	EI-337367	IC M58841-600P	134	EV-337052	VR ROTARY 16L10XOR B103
3	BL-B336202	ARM PINCH ROLLER (B) PART	66	EI-307644	IC NJM4556D	135	EV-313538	VR ROTARY 16P20x1B B103
4	BM-M3104A010A	△ MOTOR BLM-310	67	EI-213390	IC NJM4558D	136	EV-337411	VR ROTARY 16P20x2U M503 N503
5	BM-B337064	△ MOTOR OPERATION (PULLEY) PART	68	EI-201940	IC NJM4558S	137	EV-337409	VR ROTARY 16P20x2V A503
6	BM-B336989	△ REEL MOTOR (PULLEY) PART	69	EI-337025	IC NJM4562D	138	HE-337372	HEAD E E-3621-PR C
7	BR-342719	REEL TABLE (B) ASSY	70	EI-634140	IC SN74107N	139	HP-H2402A010A	HEAD COMBO PR4-5 C
8	BR-336606	REEL TABLE ASSY	71	EI-336992	IC μPC1043	140	MB-336026	BELT CAPSTAN
9	BT-337224	△ TRANS POWER T-2032(A,C)	72	EI-337237	IC μPD4050	141	MB-336021	BELT OPERATION
10	BT-337226	△ TRANS POWER T-2032(B,S)	73	EJ-283140	△ SOCKET SELECTER X-I7238 6P (U)	142	MI-336025	FLYWHEEL (B)
11	BT-337225	△ TRANS POWER T-2032(E,V)	74	EL-337053	PL CORD 16.0V 80MA 400/400	143	MP-336153	PINCH ROLLER (A)
12	BT-337223	△ TRANS POWER T-2032(J)	75	EM-337221	IND FL FIP54AW11Y DOUBLE	144	MP-336204	PINCH ROLLER (B)
13	BT-337222	△ TRANS POWER T-2032(U)	76	EO-669273	COIL FIX 2 FL5R200 18μH	145	TC-336002	HOLDER CAPSTAN (B)
14	BZ-T2030A110A	QIL CLUTCH BLK GX-F51	77	EO-337343	COIL OSC 1 2325-267 100MHZ	146	TC-B336004A	HOLDER CAPSTAN (C-1) PART
15	EC-338341	C COMP 05-0034	78	EO-315758	COIL TUN 1 100S-431 100KHZ	147	TC-336605	WIND IDLER ASSY
16	EC-300034	C S-FIX H ECR-CA100H12 9.0-100	79	EO-336738	COIL TUN 1 102AK-004 19.8KHZ			
17	EC-337366	OSC CE CSB-600C 600 KHZ	80	ER-318647	△ R FUSE ERD2FC F10 1/4W 4R7J			
18	EC-337017	OSC CE CSB800A 0.8MHZ	81	ER-336775	FILTER DB D07001K 19KHZ			
19	ED-308952	D GERMA V 1K34A-LR F07	82	ER-336776	FILTER DB D07003K 100KHZ			
20	ED-322982	D GERMA V 1S188FM-1-LR F07	83	ER-337376	R COMP 01-0399			
21	ED-337016	D LED SG203DA GRN	84	ER-337374	R COMP 01-0400			
22	ED-337010	D LED SLP-201C GRN	85	ER-337631	R COMP 01-0449			
23	ED-337238	D LED SLP-162B RED	86	ES-312234	△ SW PUSH SDL-1P 01-1 E (U,E,B,S,V)			
24	ED-337239	D LED SLP-262B GRN	87	ES-312235	△ SW PUSH SDL-1P 01-1 J (J)			
25	ED-337014	D LED SR503D RED	88	ES-312238	△ SW PUSH SDL-1P 01-1 UC (C,A)			
26	ED-337195	D LED SY403DA YLW	89	ES-336990	SW LEAF BSW-169 01-1 NO			
27	ED-301911	D SILICON H DS448	90	ES-337344	SW MICRO SS-01-ED UC			
28	ED-338229	D SILICON H DS448FB4 F12	91	ES-337257	SW PUSH SUN312A 3-THROW			
29	ED-330987	D SILICON RB152 200/1.5A	92	ES-337197	SW ROTARY SBM1023N 2-02-03N			
30	ED-200468	D SILICON V DS448-VB6	93	ES-337196	SW ROTARY SBM1024N 2-02-04N			
31	ED-306109	D SILICON W03B 100/1.0A	94	ES-283072	SW SLIDE SSC22LP 2-02-02N			
32	ED-330622	D SILICON 1SR35-100VL 100/1.0A	95	ES-336780	SW TACT KHH10902			
33	ED-338561	D ZENER H HZ2 F10 B2	96	ET-337359	PHOTO SENSOR MCD-7213P			
34	ED-337268	D ZENER H HZ5A-1	97	ET-311977	PHOTO SENSOR SPI-201			
35	ED-337265	D ZENER H HZ6C-2	98	ET-321016	TR FET 2SK117 GR,BL			
36	ED-302295	D ZENER H HZ7 C3	99	ET-337235	TR FET 2SK170 BL,V			
37	ED-306014	D ZENER H HZ9 C3	100	ET-337234	TR FET 2SK270 GR,BL			
38	ED-337266	D ZENER H HZ9A-1	101	ET-200558	TR 2SA1115 E,F			
39	ED-338316	D ZENER V HZ22-1S1	102	ET-554657	TR 2SA733A P,Q			
40	ED-337259	D ZENER V HZ6A-3S1	103	ET-337012	TR 2SA984K D,E			
41	ED-337260	D ZENER V HZ7B-2S1	104	ET-337967	TR 2SA990 E,F			
42	EF-300588	△ FUSE EAWK T 250V 0.20A (E,V)(F6)	105	ET-337233	TR 2SA995 F,G			
43	EF-695766	△ FUSE SEMKO T 250V 0.31A (B,S)(F1)	106	ET-322598	TR 2SB632K E,F			
44	EF-593706	△ FUSE SEMKO T 250V 0.50A (E,B,S,V)(F5)	107	ET-328438	TR 2SB808-V F,G			
45	EF-602550	△ FUSE SEMKO T 250V 1.25A (E,B,S,V)(F3,4)	108	ET-336997	TR 2SB808-V G,H			
46	EF-308933	△ FUSE TSC A 250A 0.20A (J)(F6)	109	ET-375603	TR 2SC1061 B,C			
47	EF-327103	△ FUSE TSC A 250V 0.50A (U,J)(F5)	110	ET-337258	TR 2SC1843 E,F			
48	EF-306949	△ FUSE TSC A 250V 1.25A (U,J)(F3,4)	111	ET-337011	TR 2SC2274K D,E			
49	EF-315334	△ FUSE TSC 125V 0.25A (C,A)(F6)	112	ET-308977	TR 2SC2274K F			
50	EF-309390	△ FUSE TSC 125V 0.50A (C,A)(F5)	113	ET-328578	TR 2SC2320 E,F			
51	EF-309392	△ FUSE TSC 125V 1.25A (C,A)(F3,4)	114	ET-200505	TR 2SC2603 E,F			
52	EI-337568	HOLE ELEMENT DHD-H070	115	ET-200985	TR 2SC2603 F,G			
53	EI-337227	IC AN6870N	116	ET-308141	TR 2SC2603 G			
54	EI-330352	IC BA6109	117	ET-639437	TR 2SC945L Q,P			
55	EI-337357	IC HA12020	118	ET-328437	TR 2SD1012-V F,G			
56	EI-322993	IC HD74107P	119	ET-328868	TR 2SD1012-V G,H			
57	EI-336761	IC LA6458S	120	ET-452531	TR 2SD313 E,F			
58	EI-337013	IC LB1290	121	ET-310148	TR 2SD612K E,F			
59	EI-337009	IC LC4049	122	ET-328440	TR 2SD863-V8 E,F			
60	EI-337008	IC LC7800	123	EV-315416	R S-FIX H D8 3P 103			
61	EI-312179	IC LM1111B	124	EV-321637	R S-FIX H D8 3P 104			
62	EI-337006	IC LM6402H-063	125	EV-314646	R S-FIX D8 3P 202			
63	EI-337228	IC M5218L0	126	EV-315752	R S-FIX H D8 3P 204			
			127	EV-322416	R S-FIX H D8 3P 303			
			128	EV-315412	R S-FIX H D8 3P 502			
			129	EV-315413	R S-FIX H D8 3P 503			
			130	EV-483388	R S-FIX H SR19R 3P 0.15W 103			
			131	EV-483377	R S-FIX H SR19R 3P 0.15W 473			
			132	EV-306016	R S-RIX H TM8KV2-1S 3P 0.50W 101			

When ordering parts, please quote Parts Number, Description and Model Number.

MECHA BLOCK

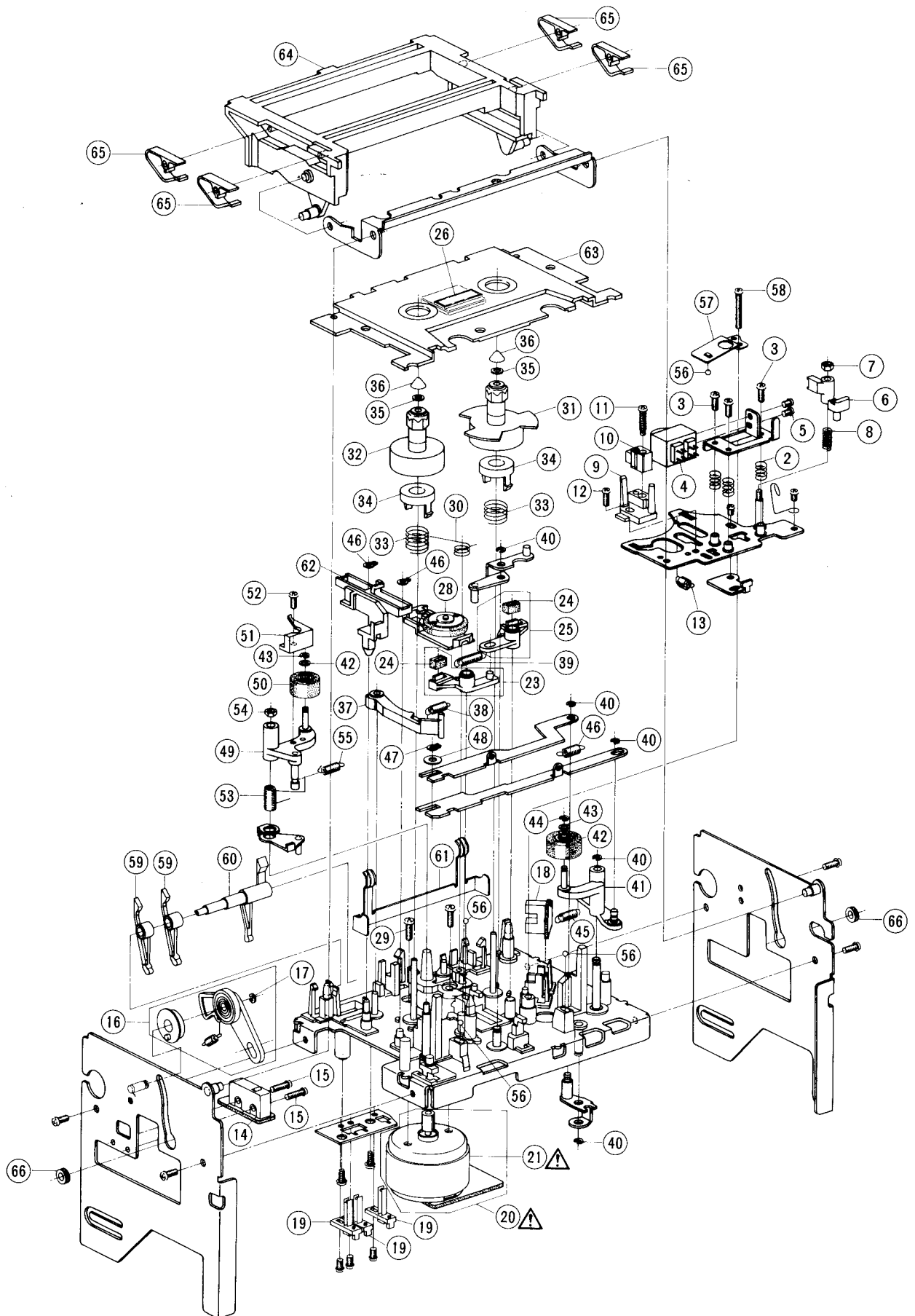

1. MECHA BLOCK

REF. NO.	PARTS NO.	DESCRIPTION	REF. NO.	PARTS NO.	DESCRIPTION
HEAD BLOCK					
1-1x	BH-T2032A080A	HEAD BLK GX-F71	1-55	ZG-336208	SP PULL PINCH ROLLER (S)
1-2	ZG-336127	SP PUSH HEAD	1-56	MV-357208	BALL200STL
1-3	ZS-608095	PAN20x05STL CMT	1-57	ZG-336157	SP PLATE HEAD HOLD
1-4	HP-H2402A010A	HEAD COMBO PR4-5 C	1-58	ZS-342002	ST PAN26x16STL CMT
1-5	ZS-477876	PAN20x03STL CMT	1-59	ML-336158	LEVER DETECTION (B)
1-6	HZ-336129	GUIDE TAPE	1-60	ML-336159	LEVER DETECTION (A)
1-7	ZW-618884	N20STL CMT 1	1-61	ZG-336160	SP PLATE CASSETTE HOLDER (A)
1-8	ZG-336130	SP PUSH GUIDE	1-62	TC-336161	SLIDE EJECT
1-9	HZ-336195	HOLDER HEAD E	1-63	BD-B336162A	LID DECORATION (A) PART
1-10	HE-337372	HEAD E E-3621-PR C	1-64	SP-336163	LID CASE
1-11	ZS-342086	PLX PAN26x12STL CMT	1-65	ZG-336615	SP PLATE CASSETTE HOLDER (B)
1-12	ZS-499331	PAN23x05STL CMT	1-66	SZ-336166	COLLAR LID
1-13	ZG-341972	SP PULL HEAD RETURN			
SW MICRO P.C BOARD BLOCK					
1-14	ES-337344	SW MICRO SS-01-ED UC (SW1)			
CHASSIS MECHA SIDE (L) BLOCK					
1-15	ZS-310337	PAN20x08STL CMT			
1-16	BZ-T2030A110A	OIL CLUTCH BLK GX-F51			
1-17	ZW-270088	RING E 190SUP CMT			
DETECTION P.C BOARD BLOCK					
1-18	ET-311977	PHOTO SENSOR SPI-201 (PH1)			
SW LEAF BLOCK					
1-19	ES-336990	SW LEAF BSW-169 01-1 NO (SW902,903,904)			
REEL MOTOR BLOCK					
1-20	BM-T2032A060A	△ REEL MOTOR BLK GX-F71			
1-21	BM-B336989	△ REEL MOTOR (PULLEY) PART			
1-22x	EO-669273	COIL FIX 2 FL5R200 18μH (L1,2)			
LEVER BRAKE (A) BLOCK					
1-23	BL-T2030A160A	LEVER BRAKE (A) BLK GX-F51			
1-24	TC-336146	BRAKE RUBBER			
LEVER BRAKE (B) BLOCK					
1-25	BL-T2030A170A	LEVER BRAKE (B) BLK GX-F51			
D LED BLOCK					
1-26	ED-337010	D LED SLF-201C GRN (D901)			
MECHA BLOCK					
1-27x	BZ-T2032A050A	MECHA BLK GX-F71			
1-28	TC-336605	WIND IDLER ASSY			
1-29	ZS-563444	BID26x08STL CMT			
1-30	ZG-336140	SP TORSION IDLER			
1-31	BR-336606	REEL TABLE ASSY			
1-32	BR-342719	REEL TABLE (B) ASSY			
1-33	ZG-336141	SP PUSH BT			
1-34	TC-336142	HOLDER BT SP			
1-35	ZW-330073	PW21x040x020			
1-36	MT-305793	REEL CAP			
1-37	BL-B336196	LEVER BT PART			
1-38	ZG-324331	SP T2-3.2/0.2-12.5 T2-041			
1-39	ZG-312946	SP T1-3.2/0.29-16.0 T1-062			
1-40	ZW-270088	RING E 190SUP CMT			
1-41	BL-B336150	ARM PINCH ROLLER (A) PART			
1-42	MP-336153	PINCH ROLLER (A)			
1-43	ZW-381644	PW21x040x013PSL			
1-44	ZW-356657	RING E 150SUP CMT			
1-45	ZG-336175	SP PULL PINCH ROLLER (T)			
1-46	ZG-321534	SP T2-3.2/0.29-12.5 T2-060			
1-47	ZW-336603	RING GRIP 285SUP ACP			
1-48	ZW-306464	PW31x070x050STL CMT			
1-49	BL-B336202	ARM PINCH ROLLER (B) PART			
1-50	MP-336204	PINCH ROLLER (B)			
1-51	HZ-336205	GUIDE TAPE (B)			
1-52	ZS-608095	PAN20x05STL CMT			
1-53	ZG-336206	SP TORSION RETURN			
1-54	ZW-618884	N20STL CMT 1			

MOTOR BLOCK

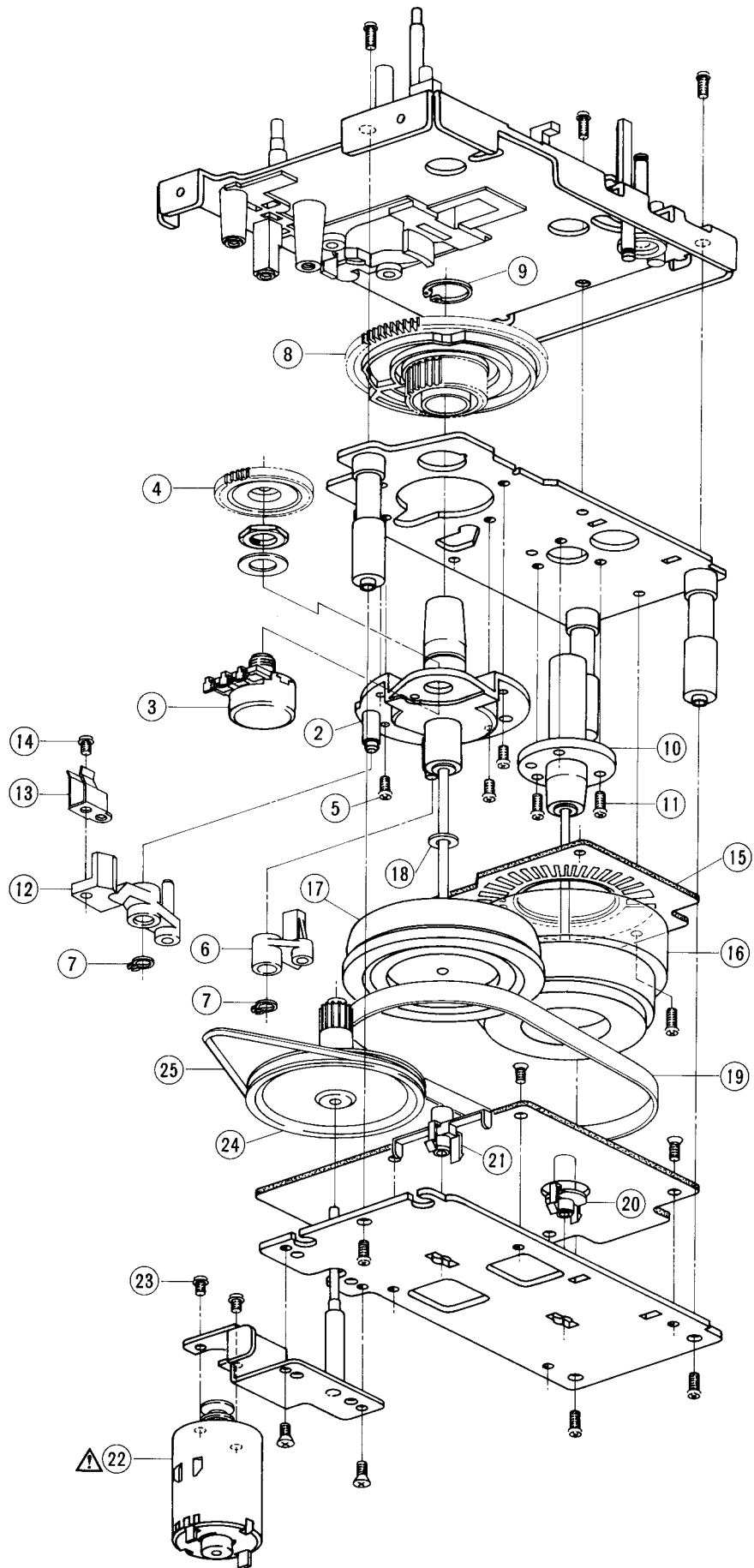

2. MOTOR BLOCK

REF. NO.	PARTS NO.	DESCRIPTION
2-1x	BM-M3104A010A	△ MOTOR BLM-310
2-2	TC-B336004A	HOLDER CAPSTAN (C-1) PART
2-3	EV-337052	VR ROTARY 16L10xOR B103
2-4	MZ-336005	GEAR POTENTION
2-5	ZS-432843	PAN26x04STL CMT
2-6	BL-B336007	LEVER BRAKE CAM PART
2-7	ZW-336603	RING GRIP 285SUP ACP
2-8	MZ-336006	CAM WHEEL
2-9	ZW-336604	RING S839SUP ACP
2-10	TC-336002	HOLDER CAPSTAN (B)
2-11	ZS-479474	PAN26x05STL CMT
2-12	BL-B336009	LEVER EJECT CAM PART
2-13	ZG-336011	SP PLATE CAM LEVER
2-14	ZS-477876	PAN20x03STL CMT
2-15	EA-336012	PC FG
2-16	BF-B336024	FLYWHEEL (A) PART
2-17	MI-336025	FLYWHEEL (B)
2-18	ZW-309295	THRUST WASHER
2-19	MB-336026	BELT CAPSTAN
2-20	TC-336016	HOLDER THRUST (A)
2-21	TC-336027	HOLDER THRUST (B)
2-22	BM-B337064	△ MOTOR OPERATION (PULLEY) PART
2-23	ZS-477876	PAN20x03STL CMT
2-24	MR-336019	PULLEY OPERATE
2-25	MB-336021	BELT OPERATION

3. PRE AMP P.C BOARD BLOCK

REF. NO.	PARTS NO.	DESCRIPTION
3-1	BA-T2032A030A	PC PRE AMP BLK GX-F71(U) (U,J,C,A)
3-2	BA-T2032A030B	PC PRE AMP BLK GX-F71(E) (E,B,S,V)
3-3	BA-T2032A030C	PC PRE AMP BLK GX-F71-P(U) (U,J,C,A)
3-4	BA-T2032A030D	PC PRE AMP BLK GX-F71-P(E) (E,B,S,V)
PRE AMP P.C BOARD		
3-IC1	EI-337025	IC NJM4562D
3-IC2to5	EI-312179	IC LM1111B
3-IC6	EI-336761	IC LA6458S
3-IC7	EI-337228	IC M5218L0
3-IC8	EI-307644	IC NJM4556D
3-IC9	EI-336761	IC LA6458S
3-IC10	EI-337228	IC M5218L0
3-IC11	EI-213390	IC NJM4558D
3-IC12	EI-336761	IC LA6458S
3-IC13	EI-634140	IC SN74107N
3-TR1to7	ET-200505	TR 2SC2603 E,F
3-TR8	ET-337233	TR 2SA995 F,G
3-TR9	ET-337234	TR FET 2SK270 GR,BL
3-TR10	ET-337258	TR 2SC1843 E,F
3-TR11	ET-337967	TR 2SA990 E,F
3-TR12	ET-337258	TR 2SC1843 E,F
3-TR13,14	ET-328578	TR 2SC2320 E,F
3-TR15	ET-337968	TR 2SA999 E,F
3-TR16	ET-328437	Δ TR 2SD1012-V F,G
3-TR17	ET-328438	Δ TR 2SB808-V F,G
3-TR18	ET-328578	TR 2SC2320 E,F
3-TR19to25	ET-200505	TR 2SC2603 E,F
3-TR26	ET-337235	TR FET 2SK170 BL,V
3-TR27	ET-200505	TR 2SC2603 E,F
3-TR28	ET-337235	TR FET 2SK170 BL,V
3-TR29,30	ET-200505	TR 2SC2603 E,F
3-TR1	ET-321016	TR FET 2SK117 GR,BL
3-TR32	ET-200505	TR 2SC2603 E,F
3-TR33	ET-200558	TR 2SA1115 E,F
3-TR34to36	ET-200505	TR 2SC2603 E,F
3-TR37	ET-308141	TR 2SC2603 G
3-TR38,39	ET-200505	TR 2SC2603 E,F
3-TR40,41	ET-200558	TR 2SA1115 E,F
3-TR42to44	ET-200505	TR 2SC2603 E,F
3-TR45,46	ET-200558	TR 2SA1115 E,F
3-TR47to50	ET-200505	TR 2SC2603 E,F
3-TR51	ET-200558	TR 2SA1115 E,F
3-TR52	ET-200505	TR 2SC2603 E,F
3-TR53	ET-200558	TR 2SA1115 E,F
3-D1	ED-308952	D GERMA V 1K34A-LR F07
3-D2,3	ED-200468	D SILICON V DS448-VB6
3-D4	ED-308952	D GERMA V 1K34A-LR F07
3-D5to7	ED-200468	D SILICON V DS448-VB6
3-D8,9	ED-322982	D GERMA V 1S188FM-1-LR F07
3-D10to23	ED-200468	D SILICON V DS448-VB6
3-D24,25	ED-330622	D SILICON 1SR35-100VL 100/1.0A
3-D26	ED-337259	D ZENER V HZ6A-3S1
3-D27	ED-200468	D SILICON V DS448-VB6
3-D28	ED-337260	D ZENER V HZ7B-2S1
3-D29to32	ED-200468	D SILICON V DS448-VB6
3-J23	EJ-337354	PIN J P 4P (U,J,C,A)
3-J23	BJ-337352	JACK PLATE GX-F71 (E,B,S,V)
3-SW1	ES-283072	SW SLIDE SSC22LP 2-02-02N (E,B,S,V)
3-SW2	ES-337257	SW PUSH SUN312A 3-THROW
3-VR1	EV-321637	R S-FIX H D8 3P 104
3-VR2	EV-337411	VR ROTARY 16P20x2U M503 N503
3-VR3	EV-337409	VR ROTARY 16P20x2V A503
3-VR4	EV-314646	R S-FIX H D8 3P 202
3-VR5	EV-306016	R S-FIX H TM8KV2-1S 3P 0.50W 101
3-VR6	EV-483388	R S-FIX H SR19R 3P 0.15W 103

REF. NO.	PARTS NO.	DESCRIPTION
3-VR7	EV-483377	R S-FIX H SR19R 3P 0.15W 473
3-VR8	EV-315412	R S-FIX H D8 3P 502
3-VR9	EV-314646	R S-FIX H D8 3P 202
3-VR10	EV-313538	VR ROTARY 16P20x1B B103
3-VR11	EV-315412	R S-FIX H D8 3P 502
3-VR12,13	EV-315416	R S-FIX H D8 3P 103
3-FL1	EO-336738	COIL TUN 1 102AK-004 19.8KHZ
3-FL2	ER-336776	FILTER DB D07003K 100KHZ
3-FL3	ER-336775	FILTER DB D07001K 19KHZ
3-FL4	ER-336776	FILTER DB D07003K 100KHZ
3-FL5	EO-336738	COIL TUN 1 102AK-004 19.8KHZ
3-R21	ER-314597	R MF H 1/4W 1302F
3-R22	ER-338108	R MF H 1/4W 4421F
3-R41	ER-314597	R MF H 1/4W 1302F
3-R79	IC-314597	R MF H 1/4W 1302F
3-R87	ER-314597	R MF H 1/4W 1302F
3-R88	ER-338108	R MF H 1/4W 4421F
3-C3	EC-337261	C EC V F05 NP NXA 1R0M 50DC
3-C5	EC-306438	C STY V F05 500 101J 50DC
3-C9	EC-337002	C EC V F05 NP NXA 100M 16DC
3-C10	EC-331183	C STY V SNP CQFS 102J 50DC
3-C11	EC-331183	C STY V SNP CQFS 102J 50DC
3-C12	EC-327097	C STY V F05 CQ09S 102J 50DC
3-C14	EC-337262	C EC V F05 NP NXA 4R7M 16DC
3-C16	EC-200948	C EC V F05 NP SM 1R0M 50DC
3-C26	EC-337262	C EC V F05 NP NXA 4R7M 16DC
3-C27	EC-331183	C STY V SNP CQFS 102J 50DC
3-C28,29	EC-327097	C STY V F05 CQ09S 102J 50DC
3-C40	EC-337966	C PP V APS 103J 100DC
3-C41	EC-337980	C PP V APS 512J 100DC
3-C46	EC-337261	C EC V F05 NXA 1R0M 50DC
3-C47	EC-337981	C PP V APS 562J 100DC
3-C49	EC-314990	C STY V SNP CQFS 101J 50DC
3-C52	EC-327097	C STY V F05 CQ09S 102J 50DC
3-C53	EC-337002	C EC V F05 NP NXA 100M 16DC
3-C55	EC-327097	C STY V F05 CQ09S 102J 50DC
3-C56	EC-337262	C EC V F05 NP NXA 4R7M 16DC
3-C57	EC-327097	C STY V F05 CQ09S 102J 50DC
3-C66	EC-337262	C EC V F05 NP NXA 4R7M 16DC
3-C67	EC-331183	C STY V SNP CQFS 102J 50DC
3-C68,69	EC-327097	C STY V F05 CQ09S 102J 50DC
3-C72	EC-200948	C EC V F05 NP SM 1R0M 50DC
3-C84	EC-306419	C STY V F05 500 681J 50DC
3-C86	EC-332052	C EC V F05 NP SM 4R7M 35DC
3-C89	EC-306987	C STY V F05 500 471J 50DC
3-C90	EC-337262	C EC V F05 NP NXA 4R7M 16DC
3-C92	EC-307793	C EC V F05 NP SM 220M 10DC
3-C99	EC-307684	C EC V F05 NP SM R47M 50DC
3-C114	EC-637143	C MC V FM 7R00D 500DC
3-C115	EC-333971	C EC V F05 NP SM 2R2M 50DC

PHONE JACK P.C BOARD

3-J24	EJ-336885	PHONE J 3P HLJ0607-023 6.3
3-J24	EJ-336886	PHONE J 3P HLJ0607-020 6.3(P)

When ordering parts, please quote Parts Number, Description and Model Number.

4. SYS. CON. P.C BOARD BLOCK

REF. NO.	PARTS NO.	DESCRIPTION
4-1	BA-T2032A090A	PC SYS CON BLK GX-F71(U)
4-2	BA-T2032A090B	PC SYS CON BLK GX-F71(J)
4-3	BA-T2032A090C	PC SYS CON BLK GX-F71(C) (C,A)
4-4	BA-T2032A090D	PC SYS CON BLK GX-F71(E) (E,V)
4-5	BA-T2032A090E	PC SYS CON BLK GX-F71(B) (B,S)

SYS. CON. P.C BOARD

4-IC1	EI-336994	IC M5230L
4-IC2	EI-336992	IC μPC1043
4-IC3,4	EI-337008	IC LC7800
4-IC5,6	EI-337013	IC LB1290
4-IC7	EI-337009	IC LC4049
4-IC8	EI-337006	IC LM6402H-063
4-IC9	EI-336761	IC LA6458S
4-IC10	EI-330352	IC BA6109
4-TR2	ET-639437	TR 2SC945L Q,P
4-TR4	ET-639437	TR 2SC945L Q,P
4-TR5	ET-328440	Δ TR 2SD863-V8 E,F
4-TR6	ET-322598	Δ TR 2SB632K E,F
4-TR7	ET-310148	Δ TR 2SD612K E,F
4-TR8,9	ET-200505	TR 2SC2603 E,F
4-TR10to14	ET-328868	TR 2SD1012-V G,H
4-TR15	ET-200505	TR 2SC2603 E,F
4-TR16,17	ET-336997	TR 2SB808-V G,H
4-TR18	ET-452531	Δ TR 2SD313 E,F
4-TR19,20	ET-328868	TR 2SD1012-V G,H
4-TR21to25	ET-200505	TR 2SC2603 E,F
4-TR26	ET-639437	Δ TR 2SC945L Q,P
4-TR27	ET-554657	TR 2SA733A P,Q
4-TR28	ET-639437	Δ TR 2SC945L Q,P
4-TR29	ET-200505	TR 2SC2603 E,F
4-TR30	ET-554657	TR 2SA733A P,Q
4-TR31,32	ET-336997	TR 2SB808-V G,H
4-TR33	ET-200505	TR 2SC2603 E,F
4-TR34	ET-639437	TR 2SC945L Q,P
4-D1,2	ED-306109	Δ D SILICON W03B 100/1.0A
4-D3,4	ED-330622	Δ D SILICON 1SR35-100VL 100/1.0A
4-D5	ED-337265	D ZENER H HZ6C-2
4-D6	ED-338316	D ZENER V HZ22-1S1
4-D7	ED-330987	Δ D SILICON RB152 200/1.5A
4-D8	ED-200468	D SILICON V DS448-VB6
4-D9	ED-302295	D ZENER H HZ7 C3
4-D10to12	ED-200468	D SILICON V DS448-VB6
4-D14	ED-200468	D SILICON V DS448-VB6
4-D15	ED-337266	D ZENER H HZ9A-1
4-D16,17	ED-337268	D ZENER H HZ5A-1
4-D18	ED-200468	D SILICON V DS448-VB6
4-D20	ED-330622	D SILICON 1SR35-100VL 100/1.0A
4-D21	ED-306014	D ZENER H HZ9 C3
4-J25	EJ-337654	DIN J UC-0044 P 8P
4-SW1	ES-312234	Δ SW PUSH SDL-1P 01-1 E (U,E,B,S,V)
4-SW1	ES-312235	Δ SW PUSH SDL-1P 01-1 J (J)
4-SW1	ES-312238	Δ SW PUSH SDL-1P 01-1 UC (C,A)
4-VR1	EV-315413	R S-FIX H D8 3P 503
4-VS1	EJ-283140	Δ SOCKET SELECTER X-17238 6P (U)
4-X1	EC-337017	OSC CE CSB800A 0.8MHZ
4-SR1	ER-337631	R COMP 01-0449
4-SR2	ER-337374	R COMP 01-0400
4-SR3	ER-337376	R COMP 01-0399
4-SR4	EC-338341	C COMP 05-0034
4-R1	ER-669330	Δ R CB H FS RDS 1/2W 102J
4-R3	ER-304667	Δ R CB H FS RDS 1/2W 272J
4-R9	ER-337303	Δ R CB H FS RDS 1/2W 472J
4-R14	ER-658034	Δ R OMF H FS 2W 221J
4-R124	ER-337251	R MF H F10 1/4W 1820F
4-R125	ER-337253	R MF H F10 1/4W 1331F

REF. NO.	PARTS NO.	DESCRIPTION
4-R126	ER-337254	R MF H F10 1/4W 2261F
4-R127	ER-337255	R MF H F10 1/4W 2871F
4-R128	ER-337256	R MF H F10 1/4W 5361F
4-C1	EC-338396	Δ C MMY V ECQEW 473M 250AC (U)
4-C1	EC-338400	Δ C MMY V ECQ-E 473M 125DC (J)
4-C1	EC-338397	Δ C MMY V ECQUE 223M 125AC (C,A)
4-C1	EC-338399	Δ C MMY V ECQUF 223M 250AC (E,B,S,V)

SW P.C BOARD

4-SW1	ES-337196	SW ROTARY SBM1024N 2-02-04N
4-SW2	ES-337197	SW ROTARY SBM1023N 2-02-03N

5. TUNING P.C BOARD BLOCK

REF. NO.	PARTS NO.	DESCRIPTION
5-1	BA-T2032A120A	PC TUNING BLK GX-F71
5-IC1	EI-337367	IC M58841-600P
5-IC2	EI-337013	IC LB1290
5-IC3	EI-337357	IC HA12020
5-IC4	EI-337228	IC M5218L0
5-IC5,6	EI-337237	IC μPD4050
5-IC7to9	EI-336761	IC LA6458S
5-TR1,2	ET-200985	TR 2SC2603 F,G
5-TR3	ET-328437	TR 2SD1012-V F,G
5-TR4to10	ET-200985	TR 2SC2603 F,G
5-TR11	ET-375603	Δ TR 2SC1061 B,C
5-TR12to18	ET-200985	TR 2SC2603 F,G
5-TR19	ET-310148	Δ TR 2SD612K E,F
5-TR20to26	ET-200985	TR 2SC2603 F,G
5-TR27	ET-310148	Δ TR 2SD612K E,F
5-TR28,29	ET-200985	TR 2SC2603 F,G
5-TR30to33	ET-308977	TR 2SC2274K F
5-TR34to41	ET-200985	TR 2SC2603 F,G
5-TR42to45	ET-200558	TR 2SA1115 E,F
5-TR46	ET-200985	TR 2SC2603 F,G
5-TR47to49	ET-200505	TR 2SC2603 E,F
5-D1	ED-200468	D SILICON V DS448-VB6
5-D2to7	ED-301911	D SILICON H DS448
5-D8to13	ED-200468	D SILICON V DS448-VB6
5-VR1	EV-322416	R S-FIX H D8 3P 303
5-VR2	EV-315413	R S-FIX H D8 3P 503
5-VR3	EV-322416	R S-FIX H D8 3P 303
5-VR4,5	EV-315752	R S-FIX H D8 3P 204
5-VR6	EV-321637	R S-FIX H D8 3P 104
5-L1	EO-302464	COIL FIX 1 RX9P-333J 33.00MH J
5-T1,2	EO-337343	COIL OSC 1 2325-267 100MHZ
5-FL1	EO-315758	COIL TUN 1 100S-431 100KHZ
5-X1	EC-337366	OSC CE CSB-600C 600 KHZ
5-PH1	ET-337359	PHOTO SENSOR MCD-7213P
5-VC1	EC-300034	C S-FIX H ECR-CA100H12 9.0-100
5-FR1to4	ER-318647	Δ R FUSE ERD2FC F10 1/4W 4R7J
5-C22	EC-332052	C EC V F05 NP SM 4R7M 35DC
5-C23	EC-317623	C STY V F05 500 102J 50DC
5-C37	EC-337249	C PP V F10 ECQ-F 222J 630DC
5-C39	EC-341496	C PP V APS 682J 100DC
5-C43	EC-306419	C STY V F05 500 681J 50DC
5-C44	EC-337250	C PP V F10 ECQ-F 102J 630DC
5-C46	EC-306419	C STY V F05 500 681J 50DC
5-C51	EC-305680	C STY V F05 500 151J 50DC
5-C66	EC-306987	C STY V F05 500 471J 50DC
5-C67	EC-316150	C STY V F05 500 821J 50DC

6. METER P.C BOARD BLOCK

REF. NO.	PARTS NO.	DESCRIPTION
6-IC1	EI-337227	IC AN6870N
6-D1,2	ED-337195	D LED SY403DA YLW
6-D3	ED-337016	D LED SG203DA GRN
6-D4	ED-337014	D LED SR503D RED
6-D5	ED-337239	D LED SLP-262B GRN
6-D6	ED-337238	D LED SLP-162B RED
6-D7to10	ED-338229	D SILICON H DS448FB4 F12
6-IN1	EM-337221	IND FL FIP54AW11Y DOUBLE
6-SW1to17	ES-336780	SW TACT KHH10902

7. MOTOR P.C BOARD BLOCK

REF. NO.	PARTS NO.	DESCRIPTION
7-IC1	EI-201940	IC NJM4558S
7-IC3	EI-337568	HOLE ELEMENT DHD-H070
7-IC4	EI-337568	HOLE ELEMENT DHD-H070
7-TR1	ET-337011	TR 2SC2274K D,E
7-TR2	ET-337012	TR 2SA984K D,E
7-TR3	ET-337011	TR 2SC2274K D,E
7-TR4	ET-337012	TR 2SA984K D,E
7-D5	ED-338561	D ZENER H HZ2 F10 B2
7-VR1,2	EV-464253	R S-FIX V V8K1-1 3P 202

8. ASSEMBLY BLOCK

REF. NO.	PARTS NO.	DESCRIPTION
----------	-----------	-------------

CHASSIS (C) BLOCK

8-1	ET-310148	TR 2SD612K E,F (TR1)
8-2	ET-322598	TR 2SB632K E,F (TR2)

ASSEMBLY BLOCK

8-3	ZW-698308	RV NYL30x055 BL
8-4x	EF-327103	△ FUSE TSC A 250V 0.50A(F2)(U)
8-5	EF-306949	△ FUSE TSC A 250V 1.25A(F3)(U)
8-6	EF-306949	△ FUSE TSC A 250V 1.25A(F4)(U)
8-7x	EF-327103	△ FUSE TSC A 250V 0.50A(F5)(U)
8-8x	EF-327103	△ FUSE TSC A 250V 0.50A(F2)(J)
8-9x	EF-306949	△ FUSE TSC A 250V 1.25A(F3)(J)
8-10x	EF-306949	△ FUSE TSC A 250V 1.25A(F4)(J)
8-11x	EF-327103	△ FUSE TSC A 250V 0.50A(F5)(J)
8-12x	EF-308933	△ FUSE TSC A 250V 0.20A(F6)(J)
8-13x	EF-309390	△ FUSE TSC 125V 0.50A(F2)(C,A)
8-14x	EF-309392	△ FUSE TSC 125V 1.25A(F3)(C,A)
8-15x	EF-309392	△ FUSE TSC 125V 1.25A(F4)(C,A)
8-16x	EF-309390	△ FUSE TSC 125V 0.50A(F5)(C,A)
8-17x	EF-315334	△ FUSE TSC 125V 0.25A(F6)(C,A)
8-18x	EF-695766	△ FUSE SEMKO T 250V 0.31A (F1)(B,S)
8-19x	EF-593706	△ FUSE SEMKO T 250V 0.50A (F2)(E,B,S,V)
8-20x	EF-602550	△ FUSE SEMKO T 250V 1.25A (F3)(E,B,S,V)
8-21x	EF-602550	△ FUSE SEMKO T 250V 1.25A (F4)(E,B,S,V)
8-22x	EF-593706	△ FUSE SEMKO T 250V 0.50A (F5)(E,B,S,V)
8-23x	EF-300588	△ FUSE EAWK T 250V 0.20A (F6)(E,V)
8-24	SP-336213A	PANEL REAR GX-F71(U) AS
8-25x	SP-336213B	PANEL REAR GX-F71 (J) AS
8-26x	SP-336213F	PANEL REAR GX-F71 (C) AS
8-27x	SP-336213C	PANEL REAR GX-F71 (A) AS
8-28x	SP-336213D	PANEL REAR GX-F71 (E,V) AS
8-29x	SP-336213E	PANEL REAR GX-F71 (B,S) AS
8-30	ZS-447761	T2BR30x06STL BNI
8-31	EW-306428	△ AC CORD 2 CORES KP-205A, VFF J (U)
8-32x	EW-306427	△ AC CORD 2 CORES KP-211, VFF J (J)
8-33x	EW-305691	△ AC CORD 2 CORES KP-8, SPT-1 UC (C,A)
8-34x	EW-313882	△ AC CORD 2 CORES KP-419C, LTCE-2F E (E,V)
8-35x	EW-313884	△ AC CORD 2 CORES GTBS-2F 24/0.20x2 B (B)
8-36x	EW-201515	△ AC CORD 2 CORES KP-560, LTSA-2FS (S)
8-37	SZ-631945	STRAIN RELIEF SR-4N-4 (U,J,C,A,E,S,V)
8-38x	EJ-692908	STRAIN RELIEF SR-5N-4 (B)
8-39	BT-337222	△ TRANS POWER T-2032 (U)
8-40x	BT-337223	△ TRANS POWER T-2032 (J)
8-41x	BT-337224	△ TRANS POWER T-2032 (A,C)
8-42x	BT-337225	△ TRANS POWER T-2032 (E,V)
8-43x	BT-337226	△ TRANS POWER T-2032 (B,S)
8-44	ZS-301398	ST BID40x08STL CMT
8-45x	SP-336215	COVER BOTTOM
8-46x	ZS-325495	T2BR30x06STL CMT
8-47	EL-337053	PL CORD 16.0V 80MA 400/400
8-48	SA-336217	FOOT
8-49x	SW-305013	RV POP32 (A)

ASSEMBLY BLOCK

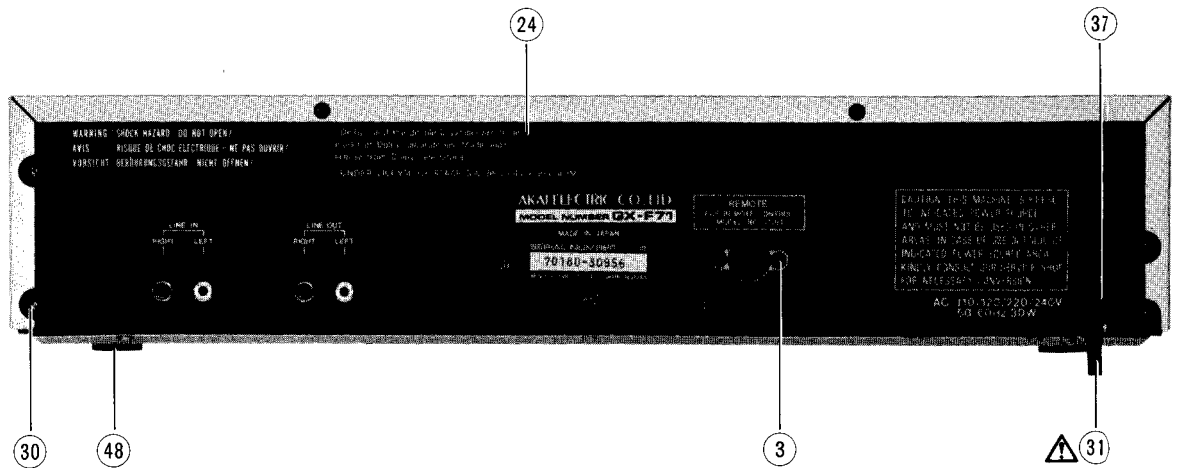
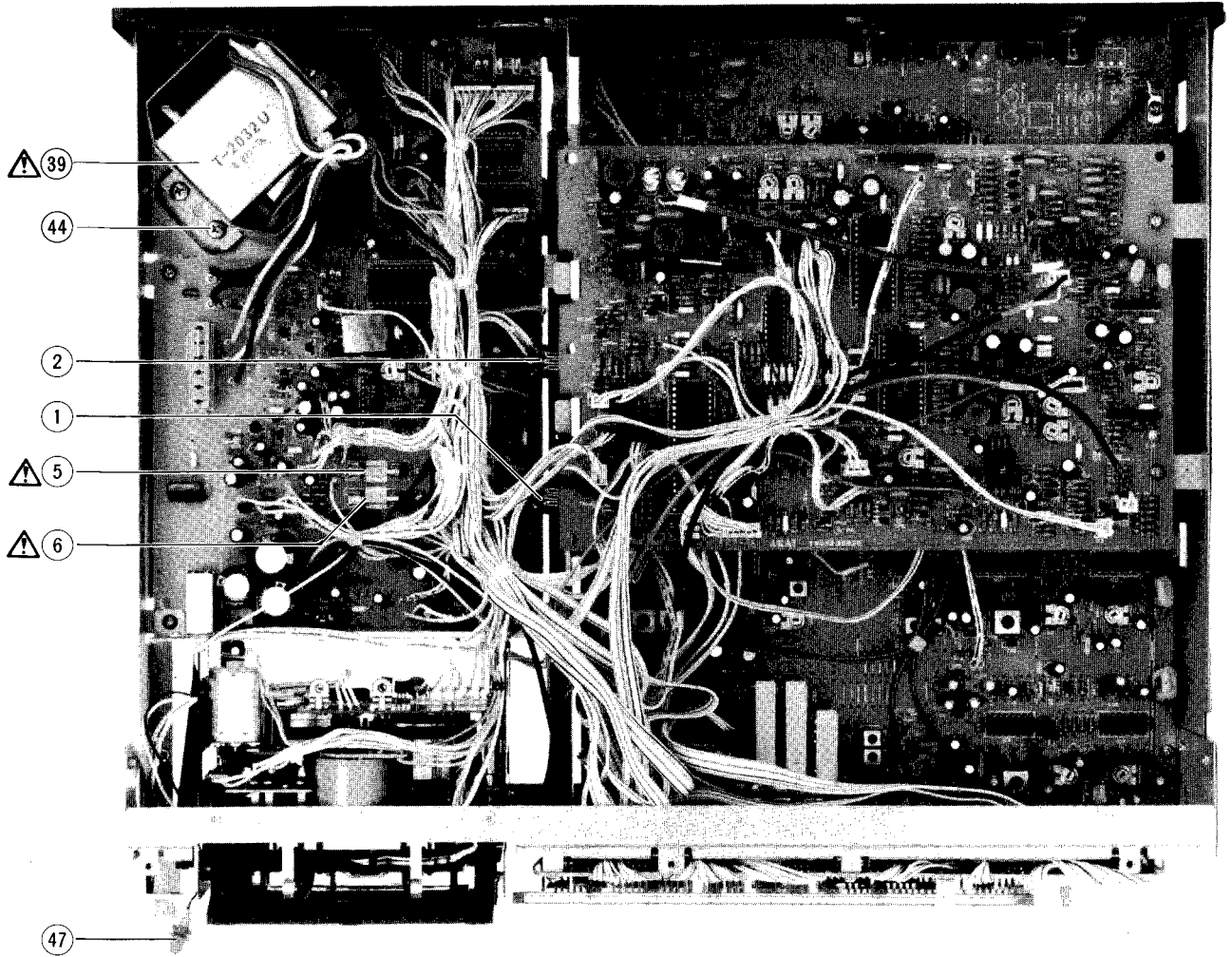

FINAL ASSEMBLY BLOCK

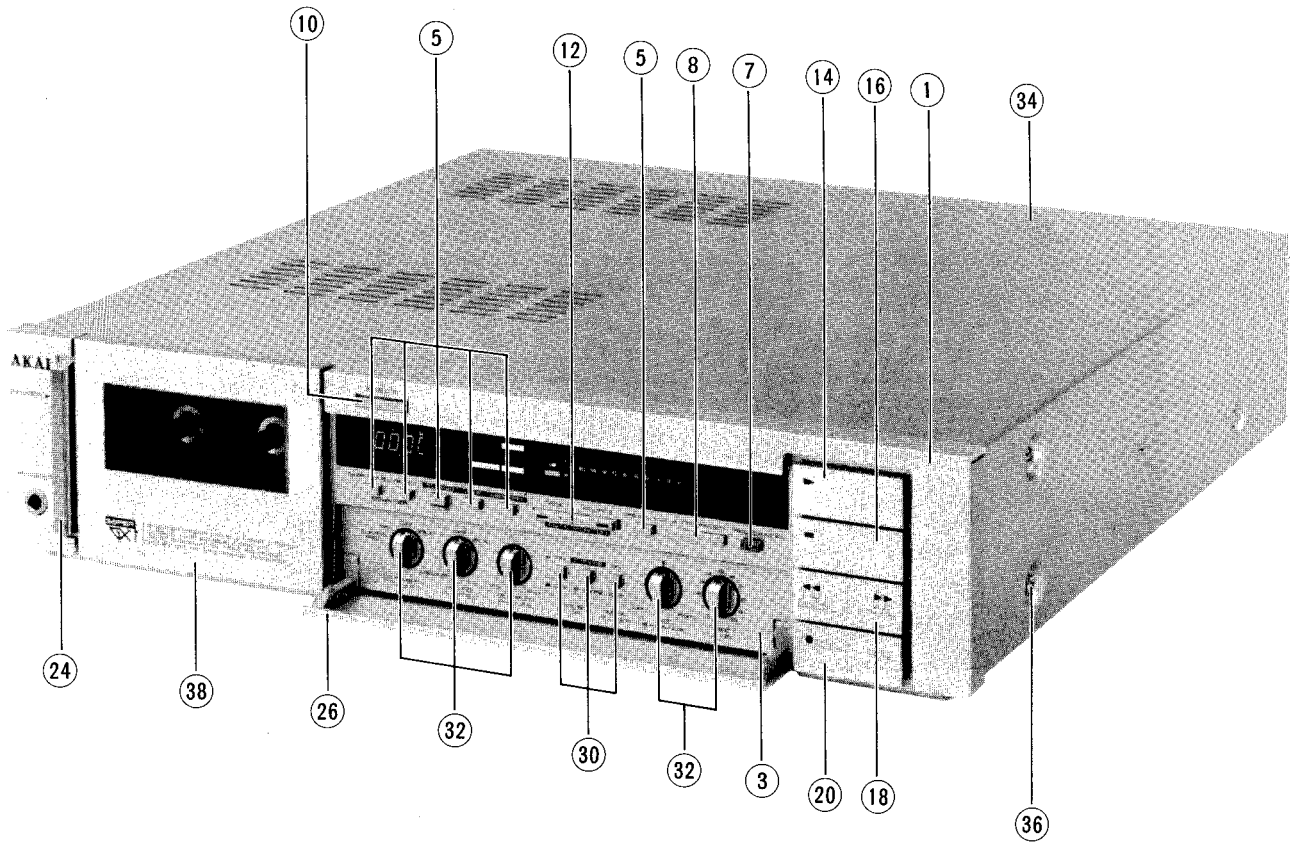

9. FINAL ASSEMBLY BLOCK

REF. NO.	PARTS NO.	DESCRIPTION
FRONT PANEL BLOCK		
9-1	SP-336223A	PANEL FRONT
9-2x	SP-336223B	PANEL FRONT-P
9-3	BD-B336224A	PANEL SUB (C) PART
9-4x	BD-B336224B	PANEL SUB (C)-P PART
9-5	SK-336237A	KNOB (A-1)
9-6x	SK-336237C	KNOB (A)-P
9-7	SK-336237B	KNOB (A-2)
9-8	SK-336239A	KNOB (B)
9-9x	SK-336239B	KNOB (B)-P
9-10	SK-336240A	KNOB (C)
9-11x	SK-336240B	KNOB (C)-P
9-12	SK-B336232A	KNOB CAP SEESAW PART
9-13x	SK-B336232B	KNOB CAP SEESAW-P PART
9-14	SK-B336241A	KNOB OPERATE (A) PART
9-15x	SK-B336241B	KNOB OPERATE (A)-P PART
9-16	SK-B336242A	KNOB OPERATE (B) PART
9-17x	SK-B336242B	KNOB OPERATE (B)-P PART
9-18	SK-B336243A	KNOB OPERATE (C-1) PART
9-19x	SK-B336243B	KNOB OPERATE (C-1)-P PART
9-20	SK-B336244A	KNOB OPERATE (D) PART

REF. NO.	PARTS NO.	DESCRIPTION
9-21x	BD-B336244B	KNOB OPERATE (D)-P PART
9-22x	SP-336236C	PANEL SUB (B-2)
9-23x	SP-336236D	PANEL SUB (B-2)-P
9-24	SK-336251	KNOB POWER
9-25x	SK-336252	KNOB SPACER
9-26	BD-T2032A150A	PANEL DOOR BLK GX-F71
9-27x	BD-T2032A150B	PANEL DOOR BLK GX-F71-P
9-28x	TC-336228A	HINGE
9-29x	TC-336228B	HINGE-P
FINAL ASSEMBLY BLOCK		
9-30	SK-336230A	KNOB PUSH
9-31x	SK-336230B	KNOB PUSH-P
9-32	SK-336229A	KNOB ROTARY
9-33x	SK-336229B	KNOB ROTARY-P
9-34	SP-336233A	COVER UPPER
9-35x	SP-336233B	COVER UPPER-P
9-36	ZS-322570	ST BID40x08STL NI3
9-37x	ZS-322580	ST BID40x08STL BNI
9-38	BD-B336235A2	LID PANEL PART
9-39x	BD-B336235B2	LID PANEL-P PART

When ordering parts, please quote Parts Number, Description and Model Number.

INDEX

1. MODEL GX-F31

PARTS NO.	REF. NO.	PARTS NO.	REF. NO.	PARTS NO.	REF. NO.	PARTS NO.	REF. NO.
BA-T2029A030A	3-1	EF-306949	7-29	ET-200505	3-TR30	SK-336240A	8-8
BA-T2029A030B	3-2	EF-309390	7-31x	ET-200505	3-TR34	SK-336240B	8-9x
BA-T2029A030C	3-3	EF-309390	7-32x	ET-200505	3-TR37	SK-336251	8-20
BA-T2029A030D	3-4	EF-309392	7-34x	ET-200505	3-TR40	SK-336252	8-21x
BA-T2029A040A	4-1	EF-309392	7-33x	ET-200505	4-TR9to17	SP-336163	1-51
BA-T2029A040B	4-2	EF-327103	7-28	ET-200505	4-TR24to27	SP-336188C	8-1
BA-T2029A040C	4-3	EF-327103	7-27	ET-200505	4-TR29	SP-336188D	8-2x
BA-T2029A040D	4-4	EF-330462	7-35x	ET-200558	3-TR7,8	SP-336190F	7-16
BA-T2029A040E	4-5	EF-593706	7-37x	ET-308976	3-TR29	SP-336190G	7-17x
BD-B336134A	8-3	EF-593706	7-38x	ET-308976	4-TR4	SP-336190H	7-18x
BD-B336134B	8-4x	EF-602550	7-40x	ET-308976	4-TR8	SP-336190J	7-20x
BD-B336162B	1-50	EF-602550	7-39x	ET-309353	3-TR33	SP-336190K	7-21x
BD-B336235A	8-30	EF-623103	7-36x	ET-310148	4-TR2,3	SP-336190M	7-19x
BD-B336235B	8-31x	EI-200938	3-IC1	ET-310148	4-TR6	SP-336191A	8-24
BD-B336244B	8-17	EI-201940	6-IC1,2	ET-310833	3-TR31,32	SP-336191B	8-25x
BF-B336013	2-16	EI-315799	5-IC1,2	ET-311977	1-17	SP-336236A	8-18x
BH-T2029A070A	2-1x	EI-330352	4-IC8	ET-318239	4-TR5	SP-336236B	8-19x
BL-B336007	2-6	EI-336761	3-IC4	ET-321016	3-TR36	SZ-336166	1-53
BL-B336009	2-12	EI-336761	3-IC7	ET-322598	3-TR28	SZ-631945	7-13
BL-B336150	1-35	EI-336761	3-IC8	ET-322598	4-TR1	TC-336002	2-10
BL-T2030A160A	1-22	EI-336761	4-IC7	ET-328437	3-TR38	TC-336004B	2-2
BL-T2030A170A	1-24	EI-336983	3-IC2	ET-328438	3-TR39	TC-336016	2-17
BM-B336989	1-20	EI-336992	4-IC9	ET-328868	3-TR17	TC-336142	1-31
BM-B337064	2-18	EI-336994	4-IC10	ET-328868	3-TR19to21	TC-336146	1-23
BM-M3103A010A	2-1x	EI-337006	4-IC1	ET-328868	4-TR22,23	TC-336161	1-48
BM-T2030A120A	1-19	EI-337008	4-IC4,5	ET-331279	3-TR18	TC-336605	1-27
BR-336606	1-29	EI-337009	4-IC6	ET-336997	4-TR18to21	ZG-312946	1-34
BT-337244	7-1	EI-337013	4-IC2,3	ET-337011	6-TR1	ZG-321534	1-41
BT-337245	7-2x	EI-337013	5-IC3	ET-337011	6-TR3	ZG-336011	2-13
BT-337246	7-3x	EI-337228	3-IC3	ET-337012	6-TR2	ZG-336127	1-2
BT-337247	7-4x	EI-337568	6-IC3,4	ET-337012	6-TR4	ZG-336130	1-8
BT-337248	7-5x	EI-338392	3-IC6	ET-452531	4-TR7	ZG-336140	1-28
BZ-T2029A080A	1-26x	EJ-283140	4-VS1	ET-554657	4-TR30	ZG-336141	1-30
BZ-T2030A110A	1-15	EJ-332435	3-J2	EV-315412	3-VR9	ZG-336157	1-43
EA-336012	2-15	EJ-332437	3-J2	EV-315413	3-VR5	ZG-336160	1-47
EC-270483	3-C93,94	EJ-336885	3-J3	EV-315414	3-VR4	ZG-336615	1-52
EC-306017	3-C98	EJ-336886	3-J3	EV-315416	3-VR10	ZG-341972	1-12
EC-306986	4-C4	EJ-337024	3-J1	EV-315416	3-VR6	ZG-342575	1-40
EC-308877	3-C81	EJ-337027	3-J1	EV-315416	3-VR8	ZS-301398	7-6x
EC-313532	3-C4	EJ-337654	4-J1	EV-336785	3-VR11,12	ZS-310337	1-14
EC-314992	3-C75	EJ-692908	7-14x	EV-337028	3-VR2	ZS-341959	8-26
EC-315335	3-C77	EL-337053	7-15	EV-337029	3-VR1	ZS-341960	8-27x
EC-331410	4-C8	EM-336988	5-IN1	EV-337030	3-VR3	ZS-342002	1-44
EC-331631	3-C63	EO-315758	3-FL5,6	EV-337052	2-3	ZS-432843	2-5
EC-337005	3-C92	EO-337044	3-FL1	EV-464220	4-VR1	ZS-463353	7-22
EC-337017	4-X1	EO-337046	3-T1	EV-464253	6-VR1,2	ZS-463353	7-24
EC-338042	3-C65	EO-337055	3-FL2	EW-201515	7-12x	ZS-465298	1-10
EC-338341	4-CR1	EO-669273	1-21x	EW-305691	7-9x	ZS-477876	1-5
EC-338396	4-C8	EO-669273	3-L1	EW-306427	7-8x	ZS-477876	2-14
EC-338400	4-C8	EP-322437	3-RL1	EW-306428	7-7	ZS-477876	2-19
EC-338419	4-C8	ER-307565	3-FR1,2	EW-313882	7-10x	ZS-479474	2-11
ED-200468	3-D14	ER-313699	4-R22	EW-313884	7-11x	ZS-608106	1-3
ED-200468	4-D9,10	ER-325270	4-R7,8	HE-337047	1-9	ZW-231030	7-23
ED-200468	4-D14	ER-336775	3-FL4	HP-H2201A010A	1-4	ZW-270088	1-16
ED-200468	4-D17,18	ER-336776	3-FL3	HZ-336129	1-6	ZW-270088	1-39
ED-200469	5-D1	ER-337283	4-R5	HZ-336131	1-11	ZW-305013	7-25x
ED-200469	5-D3	ER-337284	4-R6	MB-336021	2-21	ZW-330073	1-32
ED-301911	3-D4	ER-337287	4-FR2	ML-336158	1-45	ZW-336603	1-49
ED-301911	3-D6to11	ER-337374	4-CR2	ML-336159	1-46	ZW-336603	2-7
ED-301911	3-D13	ER-337376	4-CR3	MP-336153	1-36	ZW-336604	2-9
ED-301911	3-D16to21	ER-337631	4-CR4	MR-336019	2-20	ZW-356657	1-38
ED-301911	3-D23	ER-338231	4-R55	MT-305793	1-33	ZW-381644	1-37
ED-306109	4-D20	ER-338232	4-R56	MV-357208	1-42	ZW-618884	1-7
ED-306109	3-D2to5	ER-338233	4-R57	MZ-336005	2-4		
ED-316143	6-D1to4	ER-338234	4-R58	MZ-336006	2-8		
ED-322238	4-D1	ER-338235	4-R59	SA-336217	7-26		
ED-322982	3-D3	ES-312234	4-SW1	SK-B336241A	8-10		
ED-337010	1-25	ES-312235	4-SW1	SK-B336241B	8-11x		
ED-337014	5-D2	ES-312238	4-SW1	SK-B336242A	8-12		
ED-337016	5-D4	ES-336780	5-SW1to9	SK-B336242B	8-13x		
ED-337019	4-D7	ES-336990	1-18	SK-B336243C	8-14		
ED-337019	4-D22	ES-337043	4-SW1	SK-B336243D	8-15x		
ED-337289	4-D12	ES-337043	4-SW2	SK-B336244A	8-16		
ED-337292	3-D2	ES-337045	3-SW1	SK-336229A	8-28		
ED-338403	4-D8	ES-337344	1-13	SK-336229B	8-29x		
ED-338412	4-D6	ET-200505	3-TR2	SK-336230A	8-22		
ED-338413	3-D22	ET-200505	3-TR4	SK-336230B	8-23x		
ED-338561	6-D5	ET-200505	3-TR6	SK-336237A	8-5		
EF-300588	7-41x	ET-200505	3-TR9to16	SK-336237B	8-7		
EF-306949	7-30	ET-200505	3-TR22to27	SK-336237C	8-6x		

INDEX

2. MODEL GX-F51

PARTS NO.	REF. NO.	PARTS NO.	REF. NO.	PARTS NO.	REF. NO.	PARTS NO.	REF. NO.
BA-T2030A030A	3-1	ED-337289	4-D12	ER-338234	4-R58	HZ-336129	1-6
BA-T2030A030B	3-2	ED-337292	3-D2	ER-338235	4-R59	HZ-336131	1-11
BA-T2030A030C	3-3	ED-338403	4-D8	ES-312234	4-SW1	MB-336021	2-21
BA-T2030A030D	3-4	ED-338412	4-D6	ES-312235	4-SW1	ML-336158	1-45
BA-T2030A040A	5-1	ED-338413	3-D25	ES-312238	4-SW1	ML-336159	1-46
BA-T2030A050A	4-1	ED-338561	7-D5	ES-336780	6-SW1to13	MP-336153	1-36
BA-T2030A050B	4-2	EF-300588	8-41x	ES-336990	1-18	MR-336019	2-20
BA-T2030A050C	4-3	EF-306949	8-29	ES-337045	3-SW1to3	MT-305793	1-33
BA-T2030A050D	4-4	EF-306949	8-30	ES-337231	4-SW1	MV-357208	1-42
BA-T2030A050E	4-5	EF-309390	8-31x	ES-337232	4-SW2	MZ-336005	2-4
BD-B336162B	1-50	EF-309390	8-32x	ES-337344	1-13	MZ-336006	2-8
BD-B336189A	9-3	EF-309392	8-34x	ET-200505	3-TR9to16	SA-336217	8-26
BD-B336189B	9-4x	EF-309392	8-33x	ET-200505	3-TR22to29	SK-B336241A	9-12
BD-B336235A1	9-32	EF-327103	8-28	ET-200505	3-TR34	SK-B336241B	9-13x
BD-B336235B1	9-33x	EF-327103	8-27	ET-200505	3-TR41	SK-B336242A	9-14
BD-B336244B	9-19x	EF-330462	8-35x	ET-200505	3-TR31	SK-B336242B	9-15x
BD-336188A	9-1	EF-593706	8-38x	ET-200505	3-TR44	SK-B336243C	9-16
BD-336188B	9-2x	EF-593706	8-37x	ET-200505	3-TR2to6	SK-B336243D	9-17x
BF-B336013	2-16	EF-602550	8-39x	ET-200505	4-TR9to17	SK-B336244A	9-18
BH-T2030A190A	1-1x	EF-602550	8-40x	ET-200505	4-TR24to27	SK-336229A	9-30
BL-B336007	2-6	EF-623103	8-36x	ET-200505	4-TR29	SK-336229B	9-31x
BL-B336009	2-12	EI-200938	3-IC1	ET-200558	3-TR30	SK-336230A	9-24
BL-B336150	1-35	EI-201940	7-IC1,2	ET-200558	3-TR7,8	SK-336230B	9-25x
BL-T2030A160A	1-22	EI-213390	5-IC3	ET-200558	5-TR7to9	SK-336237A	9-5
BL-T2030A170A	1-24	EI-302233	5-IC2	ET-200558	5-TR19,20	SK-336237B	9-7
BM-B336989	1-20	EI-315799	6-IC1,2	ET-308976	4-TR4	SK-336237C	9-6x
BM-B337064	2-18	EI-330352	4-IC8	ET-308976	4-TR8	SK-336239A	9-8
BM-M3103A010A	2-1x	EI-336761	3-IC7to9	ET-309353	3-TR37	SK-336239B	9-9x
BM-T2030A120A	1-19	EI-336761	3-IC4	ET-310148	4-TR2,3	SK-336240A	9-10
BR-336606	1-29	EI-336761	4-IC7	ET-310833	3-TR35,36	SK-336240B	9-11x
BT-337244	8-1	EI-336983	3-IC2	ET-311977	1-17	SK-336251	9-22
BT-337245	8-2x	EI-336992	4-IC9	ET-316171	5-TR1to6	SK-336252	9-23x
BT-337246	8-3x	EI-336994	4-IC10	ET-316171	5-TR21,22	SP-336163	1-51
BT-337247	8-4x	EI-336995	4-IC11	ET-316171	5-TR10to18	SP-336190A	8-16
BT-337248	8-5x	EI-337006	4-IC1	ET-318239	4-TR5	SP-336190B	8-17x
BZ-T2030A080A	1-26x	EI-337008	4-IC4,5	ET-321016	3-TR38	SP-336190C	8-18x
BZ-T2030A110A	1-15	EI-337009	4-IC6	ET-322598	3-TR32	SP-336190D	8-20x
EA-336012	2-15	EI-337013	4-IC2,3	ET-322598	4-TR6	SP-336190E	8-21x
EC-306017	3-C116	EI-337013	6-IC3	ET-322598	4-TR1	SP-336190L	8-19x
EC-306986	4-C4	EI-337228	3-IC3	ET-328437	3-TR42	SP-336191A	9-26
EC-308940	3-C49,50	EI-337242	5-IC1	ET-328438	3-TR43	SP-336191B	9-27x
EC-313532	3-C4	EI-337369	3-IC5	ET-328868	3-TR19to21	SP-336236A	9-20x
EC-314992	3-C75	EI-337568	7-IC3,4	ET-328868	3-TR17	SP-336236B	9-21x
EC-329431	3-C45	EI-338392	3-IC6	ET-328868	3-TR1	SZ-336166	1-53
EC-331410	4-C8	EJ-283140	4-VS1	ET-328868	4-TR22,23	SZ-631945	8-13
EC-331631	3-C63	EJ-332435	3-J2	ET-331279	3-TR33	TC-336002	2-10
EC-332052	3-C77	EJ-332437	3-J2	ET-336997	4-TR18to21	TC-3360048	2-2
EC-333972	3-C83	EJ-336885	3-J3	ET-337011	7-TR3	TC-336016	2-17
EC-337005	3-C95	EJ-336886	3-J3	ET-337011	7-TR1	TC-336142	1-31
EC-337017	4-X1	EJ-337024	3-J1	ET-337012	7-TR4	TC-336146	1-23
EC-338042	3-C65	EJ-337027	3-J1	ET-337012	7-TR2	TC-336161	1-48
EC-338341	4-CR1	EJ-337654	4-J1	ET-337258	3-TR18	TC-336605	1-27
EC-338396	4-C8	EJ-692908	8-14x	ET-337359	3-PH1	ZG-312946	1-34
EC-338400	4-C8	EL-337053	8-15	ET-452531	4-TR7	ZG-321534	1-41
EC-338419	4-C8	EM-337243	6-IN1	ET-554657	4-TR30	ZG-336011	2-13
ED-200468	3-D14	EO-315758	3-FL5,6	EV-315412	3-VR9	ZG-336127	1-2
ED-200468	3-D21,22	EO-337044	3 FL1	EV-315413	3-VR5	ZG-336130	1-8
ED-200468	4-D17,18	EO-337046	3-T1	EV-315414	3-VR7	ZG-336140	1-28
ED-200468	4-D9,10	EO-337055	3-FL2	EV-315414	3-VR4	ZG-336141	1-30
ED-200468	4-D14	EO-669273	1-21x	EV-315416	3-VR10	ZG-336157	1-43
ED-200468	5-D1to3	EO-669273	3-L1	EV-315416	3-VR6	ZG-336160	1-47
ED-200469	6-D3	EP-322437	3-RL1	EV-321637	3-VR8	ZG-336615	1-52
ED-200469	6-D1	ER-307565	3-FR1,2	EV-336785	3-VR11	ZG-341972	1-12
ED-301911	3-D19,20	ER-313699	4-R22	EV-337028	3-VR2	ZG-342575	1-40
ED-301911	3-D4to13	ER-324251	5-R12	EV-337029	3-VR1	ZS-301398	8-6
ED-301911	3-D15to17	ER-325270	4-R7,8	EV-337030	3-VR3	ZS-310337	1-14
ED-301911	3-D1	ER-336775	3-FL4	EV-337052	2-3	ZS-341959	9-28
ED-301911	3-D26	ER-336776	3-FL3	EV-464220	4-VR1	ZS-341960	9-29x
ED-306109	4-D2to5	ER-337269	5-R78	EV-464253	7-VR1,2	ZS-342002	1-44
ED-306109	4-D20	ER-337283	4-R5	EV-464264	5-VR1,2	ZS-432843	2-5
ED-308952	3-D23,24	ER-337284	4-R6	EV-464264	5-VR4	ZS-463353	8-22
ED-309069	3-D18	ER-337286	4-FR1	EV-522663	5-VR3	ZS-463353	8-24
ED-316143	7-D1to4	ER-337287	4-FR2	EW-201515	8-12x	ZS-465298	1-10
ED-322238	4-D1	ER-337374	4-CR2	EW-305691	8-9x	ZS-477876	1-5
ED-328605	3-D3	ER-337376	4-CR3	EW-306427	8-8x	ZS-477876	2-14
ED-336998	5-D4,5	ER-337380	5-FL1	EW-306428	8-7	ZS-477876	2-19
ED-337010	1-25	ER-337631	4-CR4	EW-313882	8-10x	ZS-479474	2-11
ED-337014	6-D2	ER-338231	4-R55	EW-313884	8-11x	ZS-608106	1-3
ED-337016	6-D4	ER-338232	4-R56	HE-337047	1-9	ZW-231030	8-23
ED-337019	4-D7	ER-338233	4-R57	HP-H2201A010A	1-4	ZW-270088	1-16

INDEX

PARTS NO.	REF. NO.	PARTS NO.	REF. NO.	PARTS NO.	REF. NO.	PARTS NO.	REF. NO.
ZW-270088	1-39						
ZW-305013	8-25x						
ZW-330073	1-32						
ZW-336603	1-49						
ZW-336603	2-7						
ZW-336604	2-9						
ZW-356657	1-38						
ZW-381644	1-37						
ZW-618884	1-7						

3. MODEL GX-F71

PARTS NO.	REF. NO.	PARTS NO.	REF. NO.	PARTS NO.	REF. NO.	PARTS NO.	REF. NO.
BA-T2032A030A	3-1	EC-327097	3-C52	ED-337239	6-D5	EJ-337354	3-J23
BA-T2032A030B	3-2	EC-327097	3-C57	ED-337259	3-D26	EJ-337654	4-J25
BA-T2032A030C	3-3	EC-327097	3-C12	ED-337260	3-D28	EJ-692908	8-38x
BA-T2032A030D	3-4	EC-331183	3-C10	ED-337265	4-D5	EL-337053	8-47
BA-T2032A090A	4-1	EC-331183	3-C11	ED-337266	4-D15	EM-337221	6-IN1
BA-T2032A090B	4-2	EC-331183	3-C27	ED-337268	4-D16,17	EO-302464	5-L1
BA-T2032A090C	4-3	EC-331183	3-C67	ED-338229	6-D7to10	EO-315758	5-FL1
BA-T2032A090A	4-4	EC-332052	3-C86	ED-338316	4-D6	EO-336738	3-FL1
BA-T2032A090E	4-5	EC-332052	5-C22	ED-338561	7-D5	EO-336738	3-FL5
BA-T2032A120A	5-1	EC-333971	3-C115	EF-300588	8-23x	EO-337343	5-T1,2
BD-B336162A	1-63	EC-337002	3-C9	EF-306949	8-5	EO-669273	1-22x
BD-B336224A	9-3	EC-337002	3-C53	EF-306949	8-9x	ER-304667	4-R3
BD-B336224B	9-4x	EC-337017	4-X1	EF-306949	8-6	ER-314597	3-R41
BD-B336235A2	9-38	EC-337249	5-C37	EF-306949	8-10x	ER-314597	3-R79
BD-B336235B2	9-39x	EC-337250	5-C44	EF-308933	8-12x	ER-314597	3-R21
BD-B336244B	9-21x	EC-337261	3-C3	EF-309390	8-16x	ER-314597	3-R87
BD-T2032A150A	9-26	EC-337261	3-C46	EF-309390	8-13x	ER-318647	5-FR1to4
BD-T2032A150B	9-27x	EC-337262	3-C90	EF-309392	8-15x	ER-336775	3-FL3
BF-B336024	2-16	EC-337262	3-C56	EF-309392	8-14x	ER-336776	3-FL4
BH-T2032A080A	1-1x	EC-337262	3-C66	EF-315334	8-17x	ER-336776	3-FL2
BJ-337352	3-J23	EC-337262	3-C14	EF-327103	8-4x	ER-337251	4-R124
BL-B336007	2-6	EC-337262	3-C26	EF-327103	8-8x	ER-337253	4-R125
BL-B336009	2-12	EC-337366	5-X1	EF-327103	8-11x	ER-337254	4-R126
BL-B336150	1-41	EC-337966	3-C40	EF-327103	8-7x	ER-337255	4-R127
BL-B336196	1-37	EC-337980	3-C41	EF-593706	8-22x	ER-337256	4-R128
BL-B336202	1-49	EC-337981	3-C47	EF-593706	8-19x	ER-337303	4-R9
BL-T2030A160A	1-23	EC-338341	4-SR4	EF-602550	8-21x	ER-337374	4-SR2
BL-T2030A170A	1-25	EC-338396	4-C1	EF-602550	8-20x	ER-337376	4-SR3
BM-B336989	1-21	EC-338397	4-C1	EF-695766	8-18x	ER-337631	4-SR1
BM-B337064	2-22	EC-338399	4-C1	EI-201940	7-IC1	ER-338108	3-R22
BM-M3104A010A	2-1x	EC-338400	4-C1	EI-213390	3-IC11	ER-338108	3-R88
BM-T2032A060A	1-20	EC-341496	5-C39	EI-307644	3-IC8	ER-658034	4-R14
BR-336606	1-31	EC-637143	3-C114	EI-312179	3-IC2to5	ER-669330	4-R1
BR-342719	1-32	ED-200468	3-D5to7	EI-330352	4-IC10	ES-283072	3-SW1
BT-337222	8-39	ED-200468	3-D10to23	EI-336761	3-IC6	ES-312234	4-SW1
BT-337223	8-40x	ED-200468	3-D2,3	EI-336761	3-IC12	ES-312235	4-SW1
BT-337224	8-41x	ED-200468	3-D29to32	EI-336761	3-IC9	ES-312238	4-SW1
BT-337225	8-42x	ED-200468	3-D27	EI-336761	4-IC9	ES-336780	6-SW1to17
BT-337226	8-43x	ED-200468	4-D18	EI-336761	5-IC7to9	ES-336990	1-19
BZ-T2030A110A	1-16	ED-200468	4-D14	EI-336992	4-IC2	ES-337196	4-SW1
BZ-T2032A050A	1-27x	ED-200468	4-D8	EI-336994	4-IC1	ES-337197	4-SW2
EA-336012	2-15	ED-200468	4-D10to12	EI-337006	4-IC8	ES-337257	3-SW2
EC-200948	3-C72	ED-200468	5-D8to13	EI-337008	4-IC3,4	ES-337344	1-14
EC-200948	3-C16	ED-200468	5-D1	EI-337009	4-IC7	ET-200505	3-TR32
EC-300034	5-VC1	ED-301911	5-D2to7	EI-337013	4-IC5,6	ET-200505	3-TR42to44
EC-305680	5-C51	ED-302295	4-D9	EI-337013	5-IC2	ET-200505	3-TR47to50
EC-306419	3-C84	ED-306014	4-D21	EI-337025	3-IC1	ET-200505	3-TR34to36
EC-306419	5-C46	ED-306109	4-D1,2	EI-337227	6-IC1	ET-200505	3-TR19to25
EC-306419	5-C43	ED-308952	3-D1	EI-337228	3-IC10	ET-200505	3-TR29,30
EC-306438	3-C5	ED-308952	3-D4	EI-337228	3-IC7	ET-200505	3-TR38,39
EC-306987	3-C89	ED-322982	3-D8.9	EI-337228	5-IC4	ET-200505	3-TR52
EC-306987	5-C66	ED-330622	3-D24,25	EI-337237	5-IC5,6	ET-200505	3-TR1to7
EC-307684	3-C99	ED-330622	4-D3,4	EI-337357	5-IC3	ET-200505	3-TR27
EC-307793	3-C92	ED-330622	4-D20	EI-337367	5-IC1	ET-200505	4-TR15
EC-314990	3-C49	ED-330987	4-D7	EI-337568	7-IC3	ET-200505	4-TR29
EC-316150	5-C67	ED-337010	1-26	EI-337568	7-IC4	ET-200505	4-TR33
EC-317623	5-C23	ED-337014	6-D4	EI-634140	3-IC13	ET-200505	4-TR8,9
EC-327097	3-C28,29	ED-337016	6-D3	EJ-283140	4-VS1	ET-200505	4-TR21to25
EC-327097	3-C68,69	ED-337195	6-D1,2	EJ-336885	3-J24	ET-200505	5-TR47to49
EC-327097	3-C55	ED-337238	6-D6	EJ-336886	3-J24	ET-200558	3-TR33

INDEX

PARTS NO.	REF. NO.	PARTS NO.	REF. NO.	PARTS NO.	REF. NO.	PARTS NO.	REF. NO.
ET-200558	3-TR40,41	HE-337372	1-10	ZG-341972	1-13		
ET-200558	3-TR45,46	HP-H2402A010A	1-4	ZS-301398	8-44		
ET-200558	3-TR53	HZ-336129	1-6	ZS-310337	1-15		
ET-200558	3-TR51	HZ-336195	1-9	ZS-322570	9-36		
ET-200558	5-TR42to45	HZ-336205	1-51	ZS-322580	9-37x		
ET-200985	5-TR12to18	MB-336021	2-25	ZS-325495	8-46x		
ET-200985	5-TR28,29	MB-336026	2-19	ZS-342002	1-58		
ET-200985	5-TR1,2	MI-336025	2-17	ZS-342086	1-11		
ET-200985	5-TR20to26	ML-336158	1-59	ZS-432843	2-5		
ET-200985	5-TR4to10	ML-336159	1-60	ZS-447761	8-30		
ET-200985	5-TR34to41	MP-336153	1-42	ZS-477876	1-5		
ET-200985	5-TR46	MP-336204	1-50	ZS-477876	2-14		
ET-308141	3-TR37	MR-336019	2-24	ZS-477876	2-23		
ET-308977	5-TR30to33	MT-305793	1-36	ZS-479474	2-11		
ET-310148	4-TR7	MV-357208	1-56	ZS-499331	1-12		
ET-310148	5-TR27	MZ-336005	2-4	ZS-563444	1-29		
ET-310148	5-TR19	MZ-336006	2-8	ZS-608095	1-52		
ET-310148	8-1	SA-336217	8-48	ZS-608095	1-3		
ET-311977	1-18	SK-B336232A	9-12	ZW-270088	1-17		
ET-321016	3-TR31	SK-B336232B	9-13x	ZW-270088	1-40		
ET-322598	4-TR6	SK-B336241A	9-14	ZW-305013	8-49x		
ET-322598	8-2	SK-B336241B	9-15x	ZW-306464	1-48		
ET-328437	3-TR16	SK-B336242A	9-16	ZW-309295	2-18		
ET-328437	5-TR3	SK-B336242B	9-17x	ZW-330073	1-35		
ET-328438	3-TR17	SK-B336243A	9-18	ZW-336603	1-47		
ET-328440	4-TR5	SK-B336243B	9-19x	ZW-336603	2-7		
ET-328578	3-TR13,14	SK-B336244A	9-20	ZW-336604	2-9		
ET-328578	3-TR18	SK-336229A	9-32	ZW-356657	1-44		
ET-328868	4-TR10to14	SK-336229B	9-33x	ZW-381644	1-43		
ET-328868	4-TR19,20	SK-336230A	9-30	ZW-618884	1-54		
ET-336997	4-TR31,32	SK-336230B	9-31x	ZW-618884	1-7		
ET-336997	4-TR16,17	SK-336237A	9-5	ZW-698308	8-3		
ET-337011	7-TR3	SK-336237B	9-7				
ET-337011	7-TR1	SK-336237C	9-6x				
ET-337012	7-TR4	SK-336239A	9-8				
ET-337012	7-TR2	SK-336239B	9-9x				
ET-337233	3-TR8	SK-336240A	9-10				
ET-337234	3-TR9	SK-336240B	9-11x				
ET-337235	3-TR28	SK-336251	9-24				
ET-337235	3-TR26	SK-336252	9-25x				
ET-337258	3-TR10	SP-336163	1-64				
ET-337258	3-TR12	SP-336213A	8-24				
ET-337259	5-PH1	SP-336213B	8-25x				
ET-337967	3-TR11	SP-336213C	8-27x				
ET-337968	3-TR15	SP-336213D	8-28x				
ET-375603	5-TR11	SP-336213E	8-29x				
ET-452531	4-TR18	SP-336213F	8-26x				
ET-554657	4-TR30	SP-336215	8-45x				
ET-554657	4-TR27	SP-336223A	9-1				
ET-639437	4-TR4	SP-336223B	9-2x				
ET-639437	4-TR28	SP-336233A	9-34				
ET-639437	4-TR34	SP-336233B	9-35x				
ET-639437	4-TR2	SP-336236C	9-22x				
ET-639437	4-TR26	SP-336236D	9-23x				
EV-306016	3-VR5	SZ-336166	1-66				
EV-313538	3-VR10	SZ-631945	8-37				
EV-314646	3-VR4	TC-B336004A	2-2				
EV-314646	3-VR9	TC-336002	2-10				
EV-315412	3-VR8	TC-336016	2-20				
EV-315412	3-VR11	TC-336027	2-21				
EV-315413	4-VR1	TC-336142	1-34				
EV-315413	5-VR2	TC-336146	1-24				
EV-315416	3-VR12,13	TC-336161	1-62				
EV-315752	5-VR4,5	TC-336228A	9-28x				
EV-321637	3-VR1	TC-336228B	9-29x				
EV-321637	5-VR6	TC-336605	1-28				
EV-322416	5-VR3	ZG-312946	1-39				
EV-322416	5-VR1	ZG-321534	1-46				
EV-337052	2-3	ZG-324331	1-38				
EV-337409	3-VR3	ZG-336011	2-13				
EV-337411	3-VR2	ZG-336127	1-2				
EV-464253	7-VR1,2	ZG-336130	1-8				
EV-483377	3-VR7	ZG-336140	1-30				
EV-483388	3-VR6	ZG-336141	1-33				
EW-201515	8-36x	ZG-336157	1-57				
EW-305691	8-33x	ZG-336160	1-61				
EW-306427	8-32x	ZG-336175	1-45				
EW-306428	8-31	ZG-336206	1-53				
EW-313882	8-34x	ZG-336208	1-55				
EW-313884	8-35x	ZG-336615	1-65				

SECTION 6

SCHEMATIC DIAGRAM

1. SCHEMATIC DIAGRAM OF ICs
2. GX-F31 POWER & SYSCON NO. 2-1 1640824A SCHEMATIC DIAGRAM
3. GX-F31 AMP NO. 2-2 1640825A SCHEMATIC DIAGRAM
4. GX-F51 POWER & SYSCON NO. 3-1 1640826A SCHEMATIC DIAGRAM
5. GX-F51 AMP NO. 3-2 1640827A SCHEMATIC DIAGRAM
6. GX-F51 TUNING NO. 3-3 1640828A SCHEMATIC DIAGRAM
7. GX-F71 POWER & SYSCON NO. 3-1 1640830A SCHEMATIC DIAGRAM
8. GX-F71 AMP NO. 3-2 1640831A SCHEMATIC DIAGRAM
9. GX-F71 TUNING NO. 3-3 1640832A SCHEMATIC DIAGRAM

BA6109

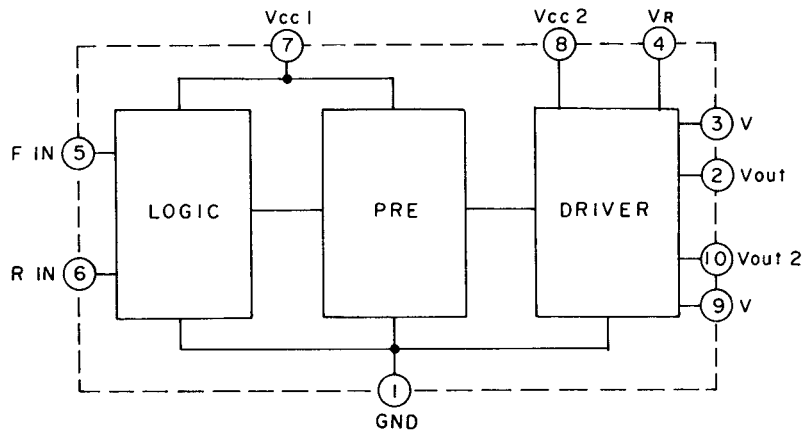

HA12019

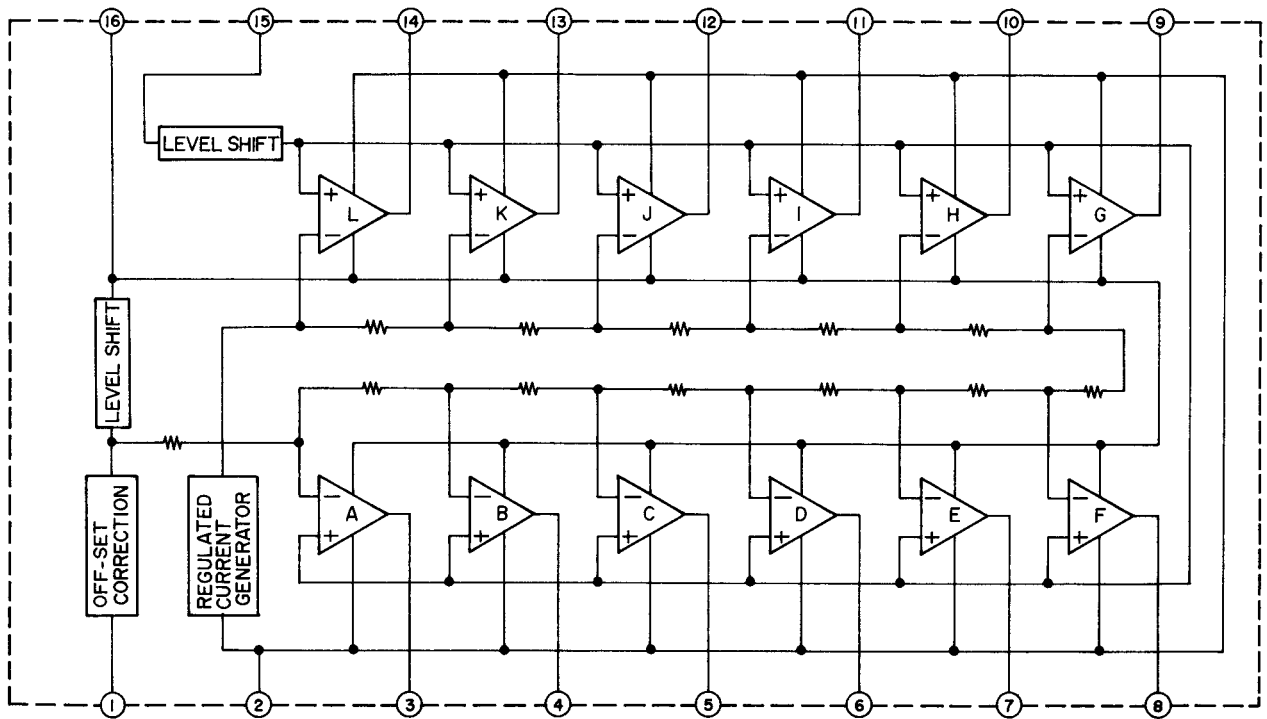

HA12020

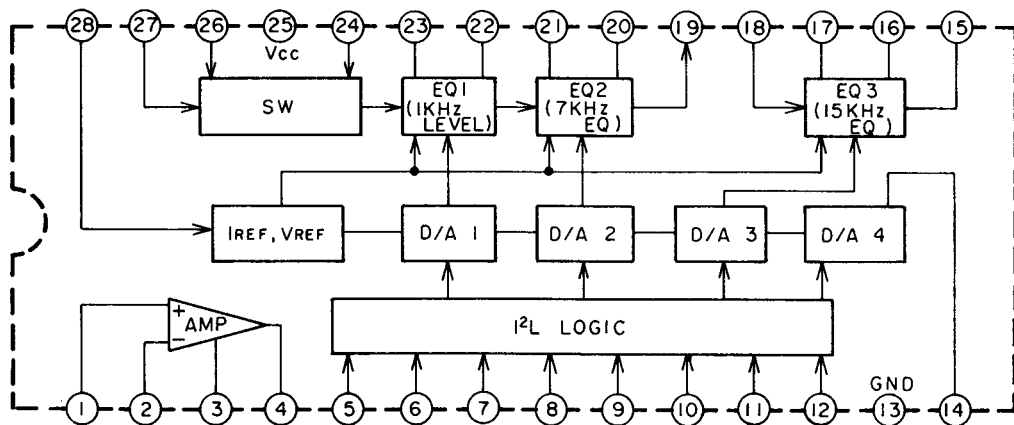

HA12038

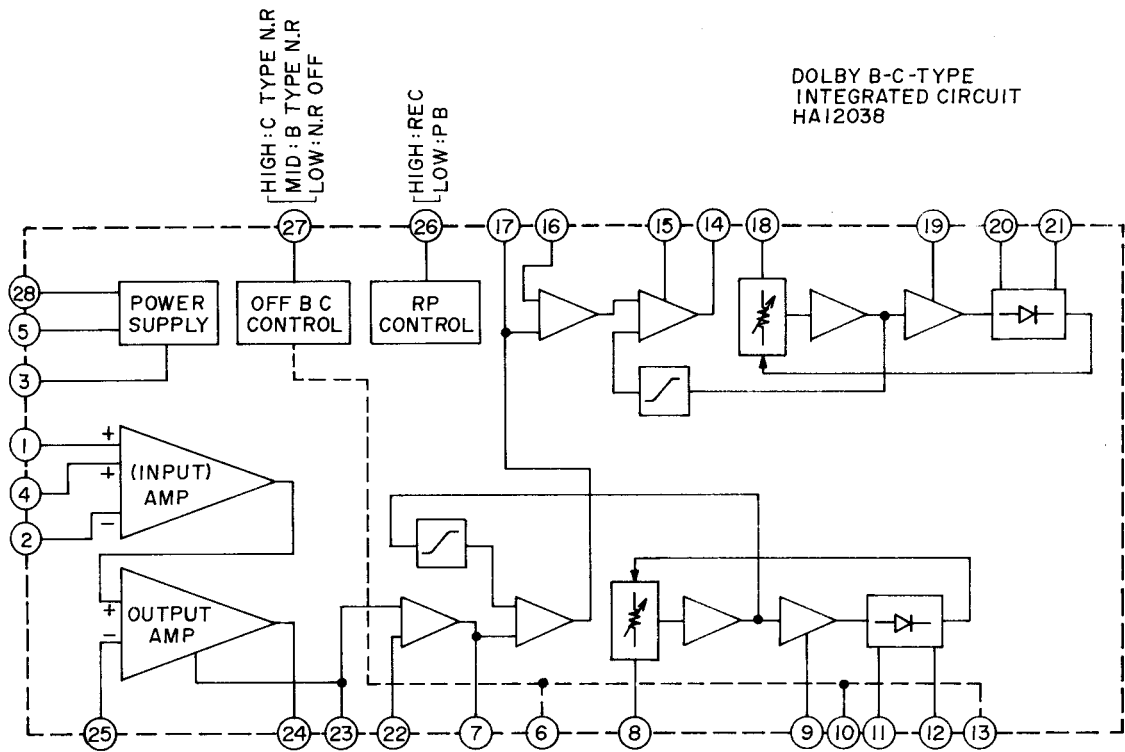

HD74107P

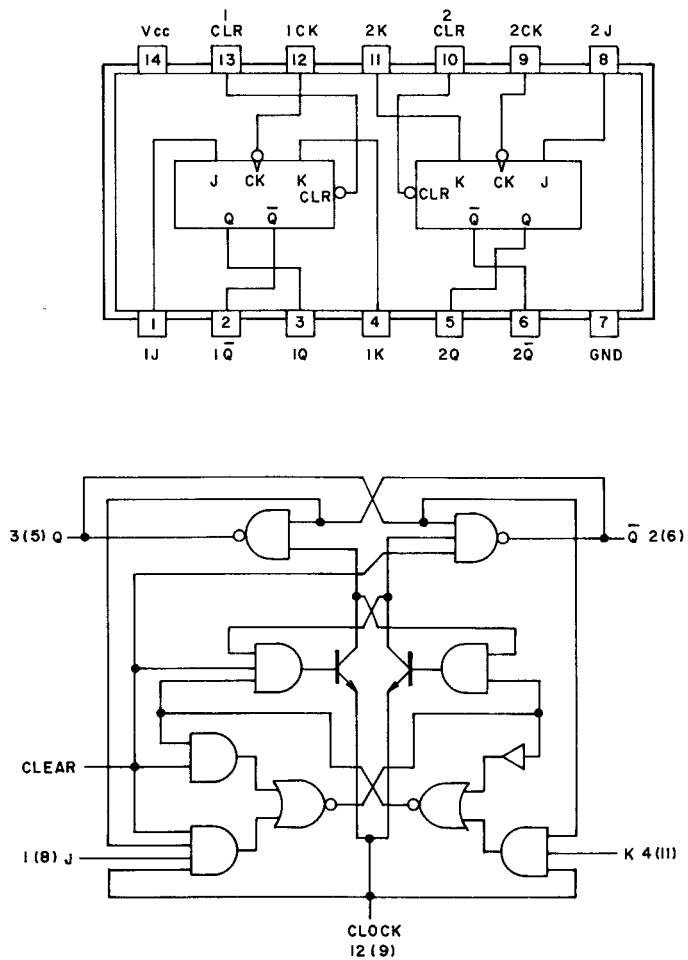

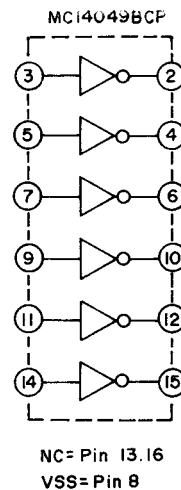
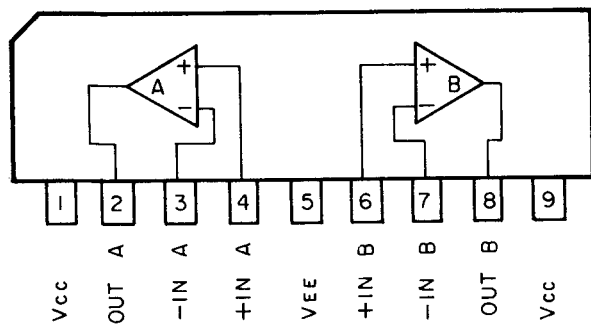

LB1290

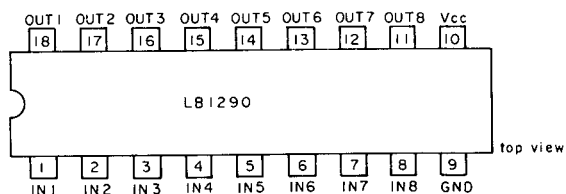
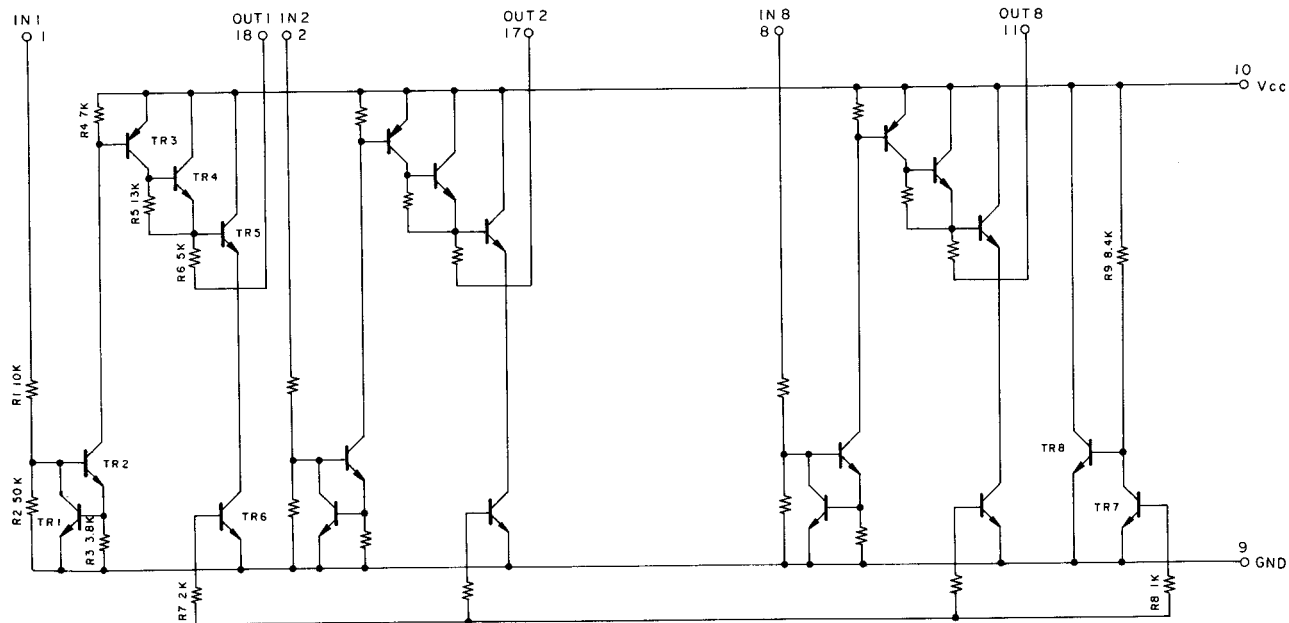

LC7800

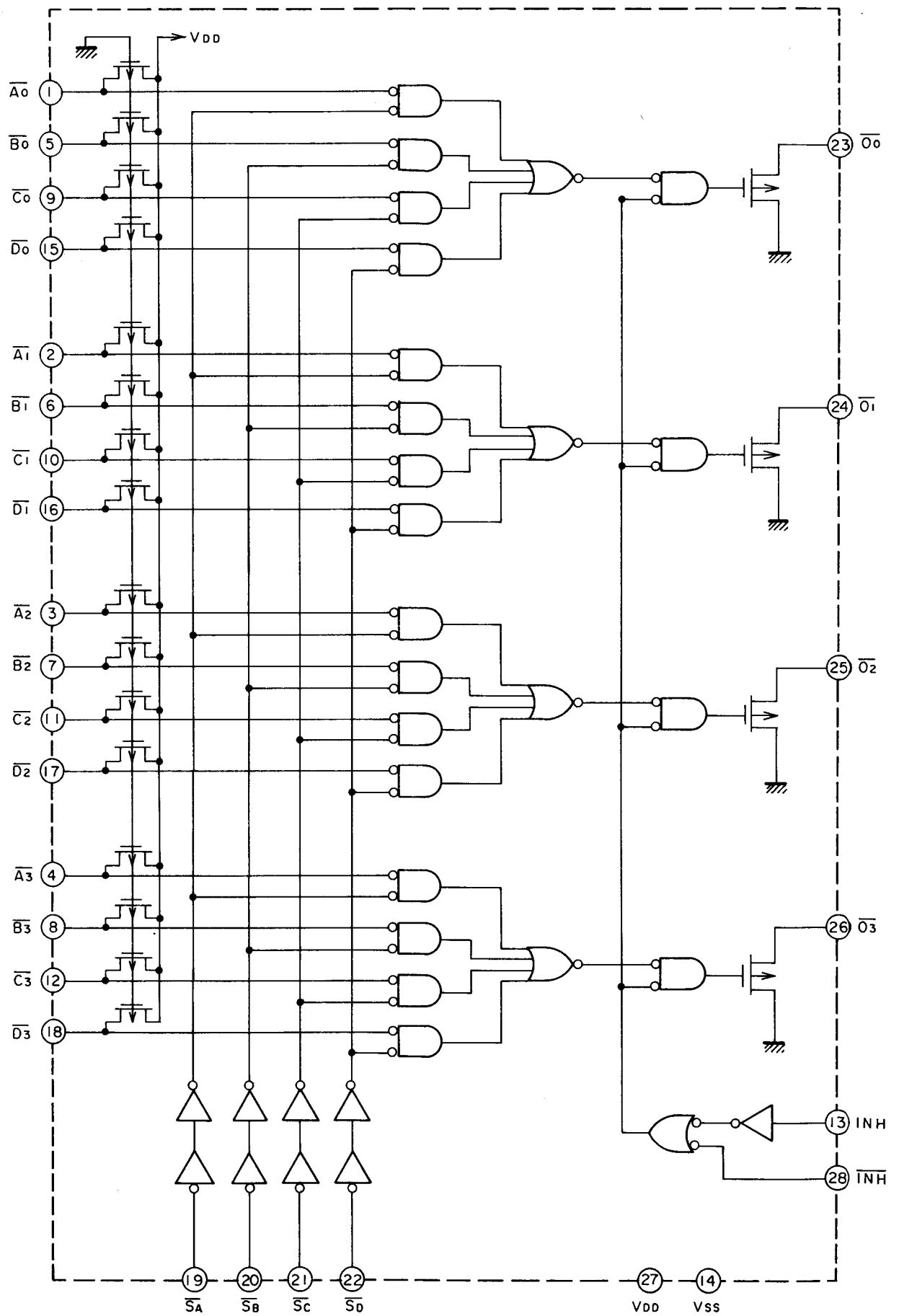

LM1111B

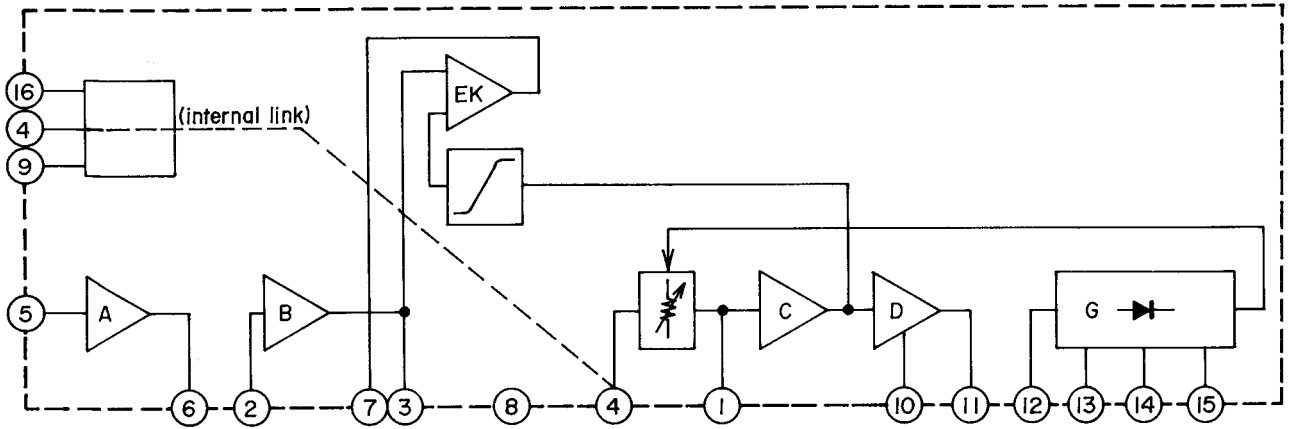

LM6402

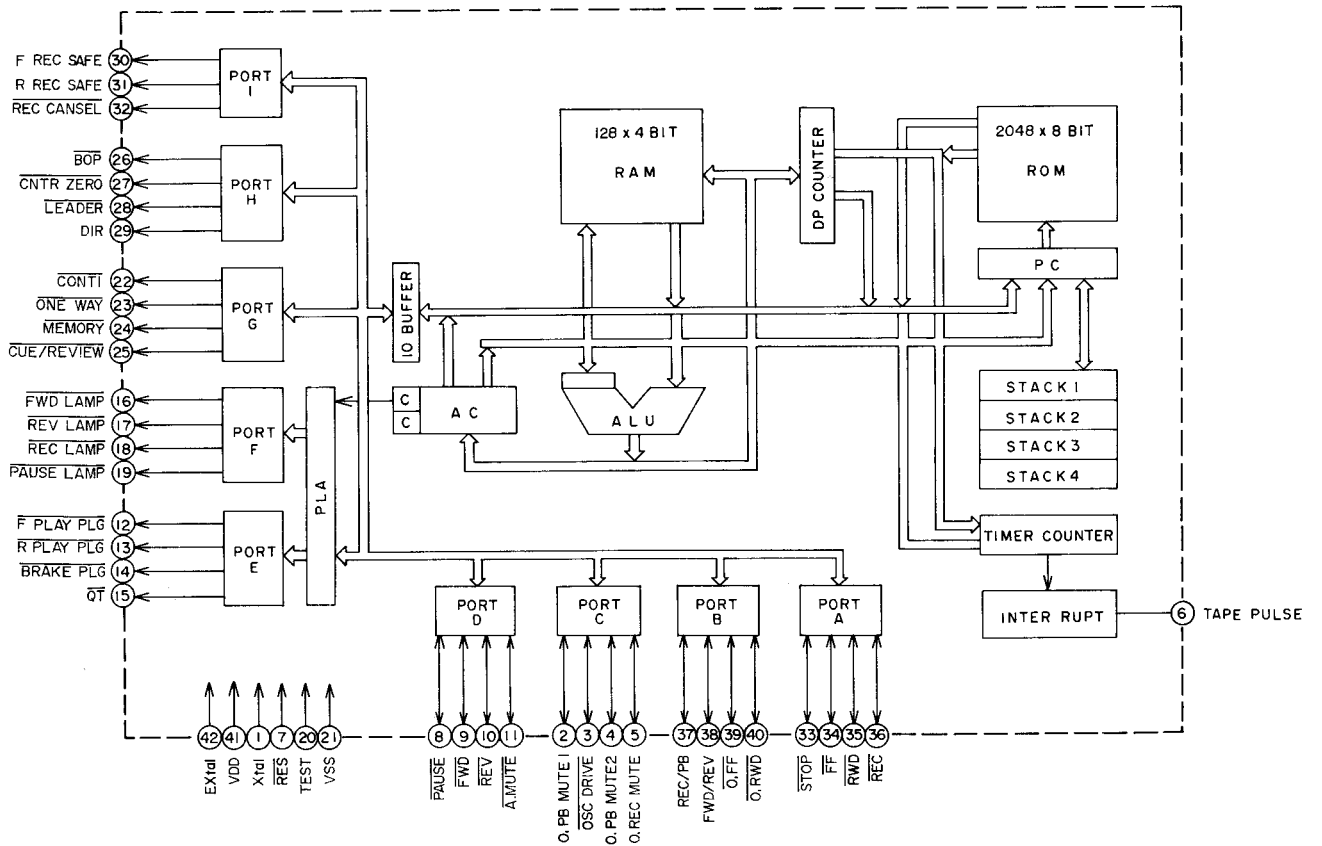

M5218LS

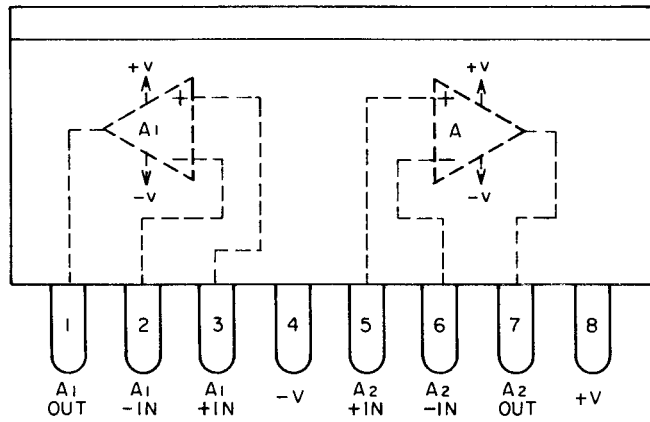

M5230L

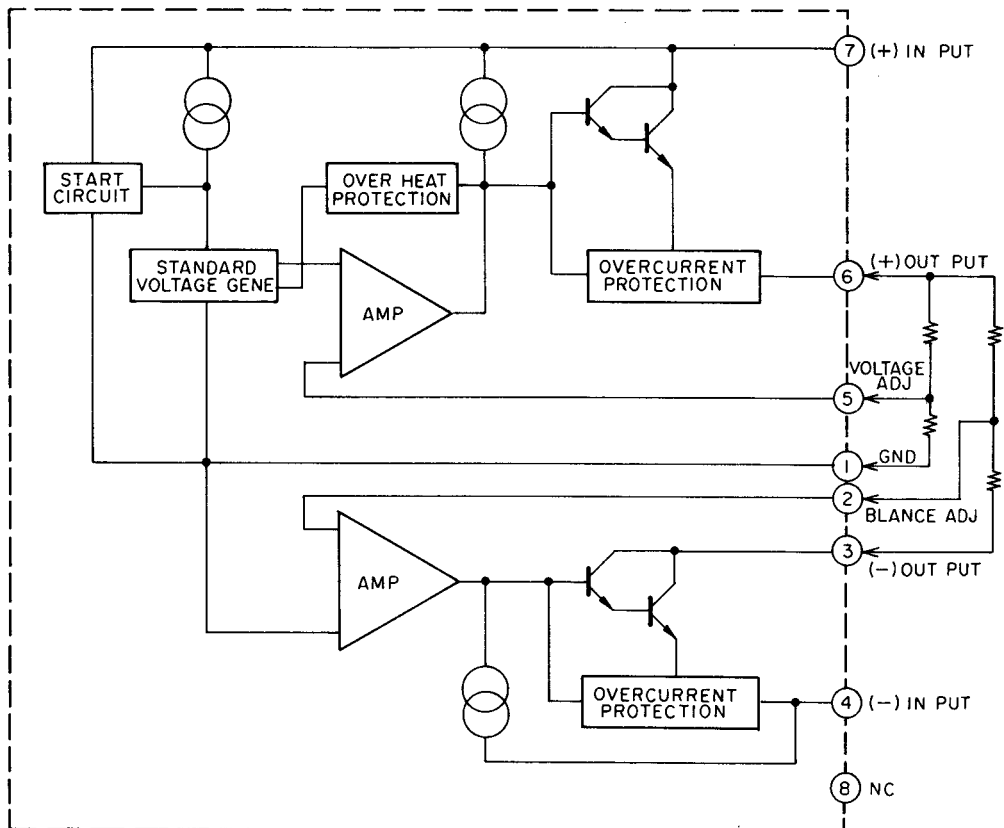
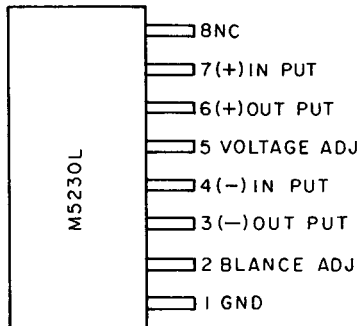

NJM4558D, NJM4556D, NJM4562D

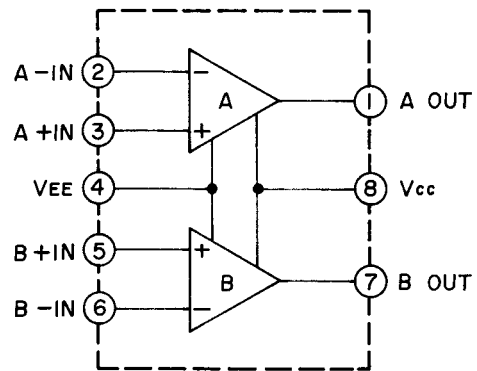

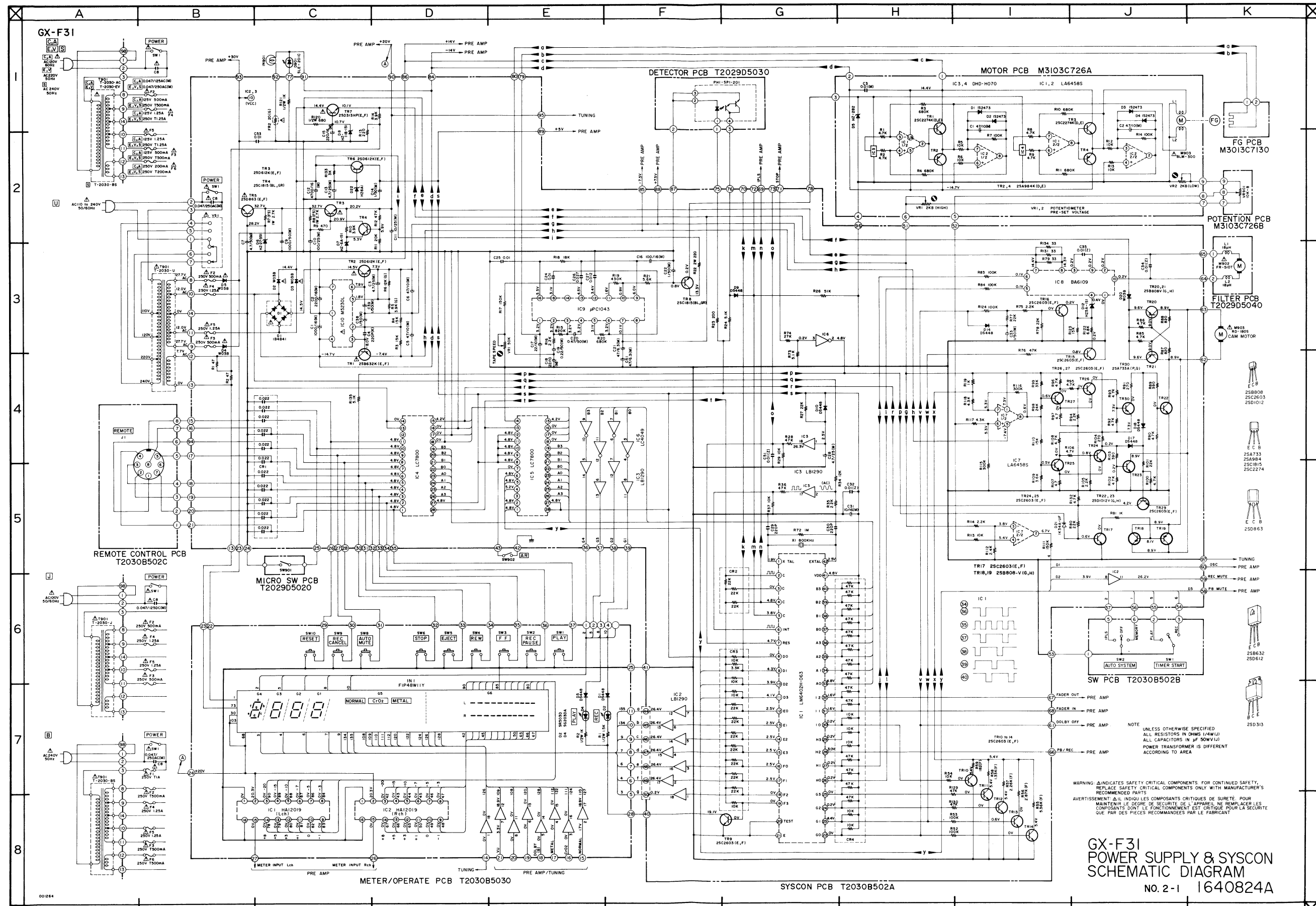

**GX-F31
POWER SUPPLY & SYSCON
SCHEMATIC DIAGRAM
NO. 2-1 1640824A**

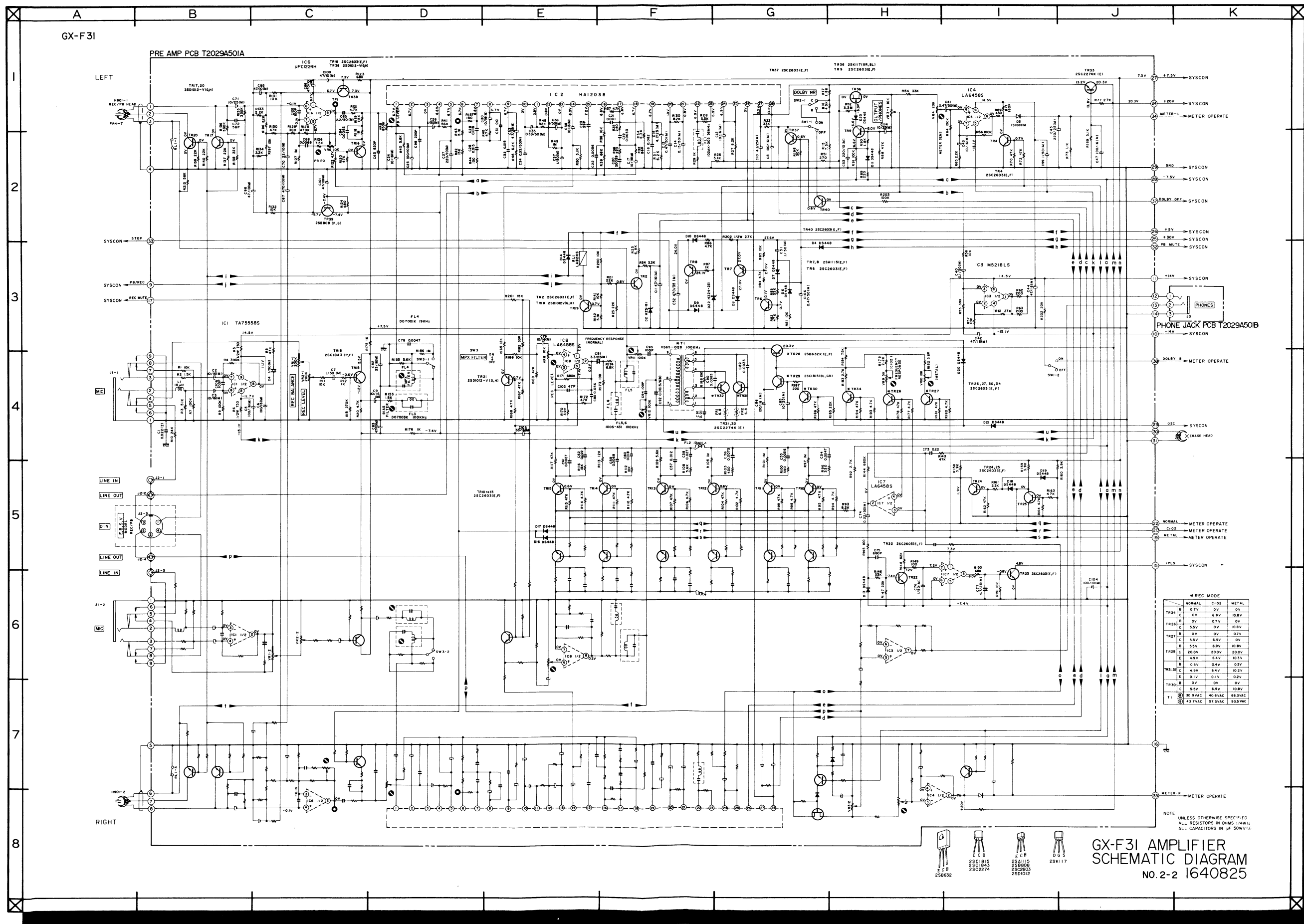

W REC MODE				
	NORMAL	C102	METAL	
TR34	B	0.7V	0V	0V
	C	0V	8.9V	10.8V
TR28	B	0V	0.7V	0V
	C	5.5V	0V	10.8V
TR27	B	0V	0V	0.7V
	C	5.5V	8.9V	10.8V
TR29	C	20.0V	20.0V	20.0V
	E	4.9V	8.4V	10.3V
	B	0.5V	0.4V	0.2V
TR31,M	C	4.9V	8.4V	10.2V
	E	0.1V	0.1V	0.2V
TR30	B	0V	0V	0V
	C	5.5V	8.9V	10.8V
T1	Ⓟ	30.9VAC	40.8VAC	66.3VAC
	Ⓠ	43.7VAC	57.3VAC	93.5VAC

NOTE
UNLESS OTHERWISE SPECIFIED
ALL RESISTORS IN OHMS /WATT
ALL CAPACITORS IN P.F. 50WV.U.

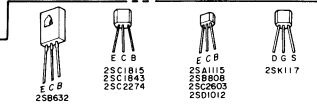

GX-F31 AMPLIFIER
SCHEMATIC DIAGRAM
NO.2-2 1640825

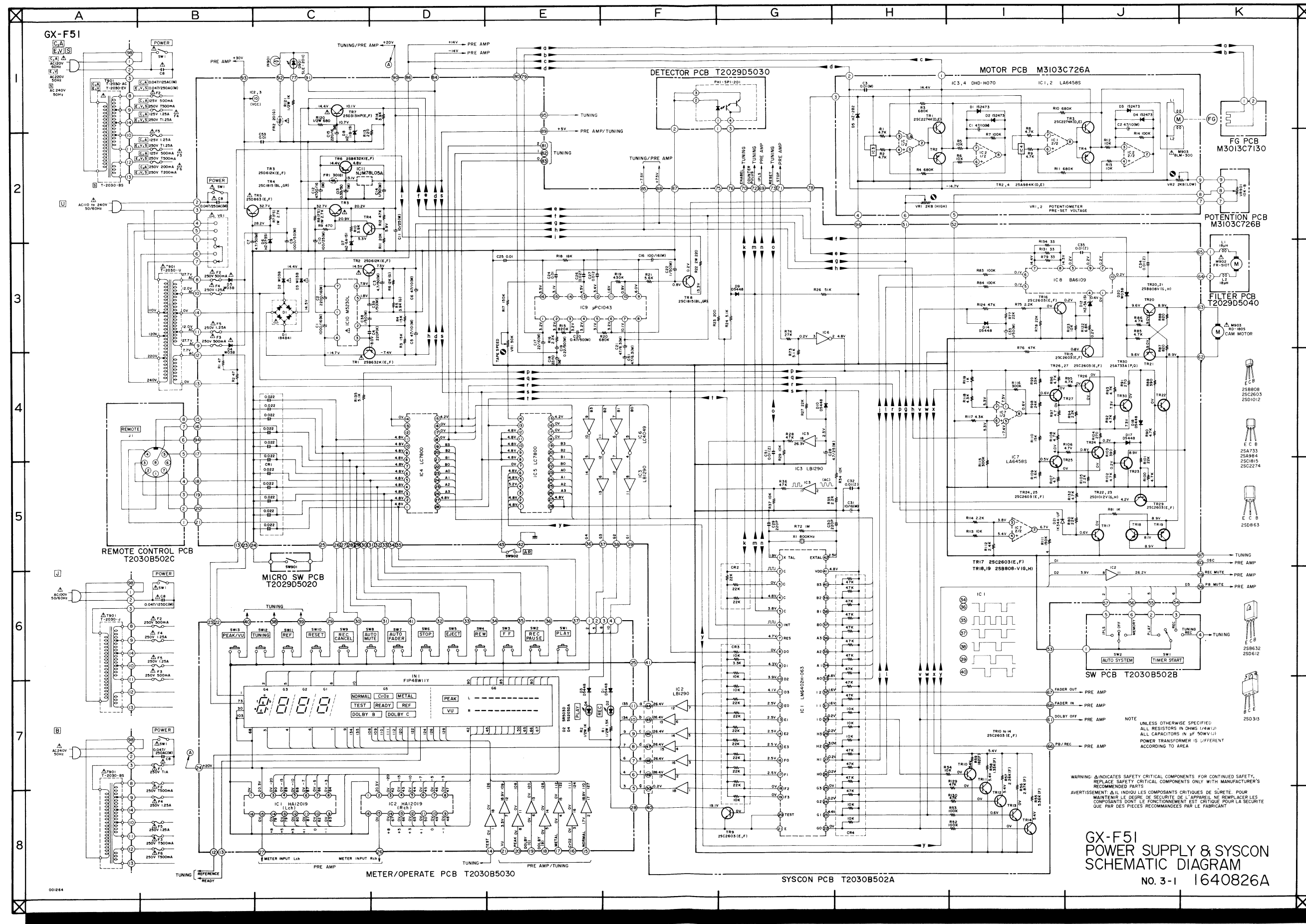

GX-F51
POWER SUPPLY & SYSCON
SCHEMATIC DIAGRAM
NO. 3-1 1640826A

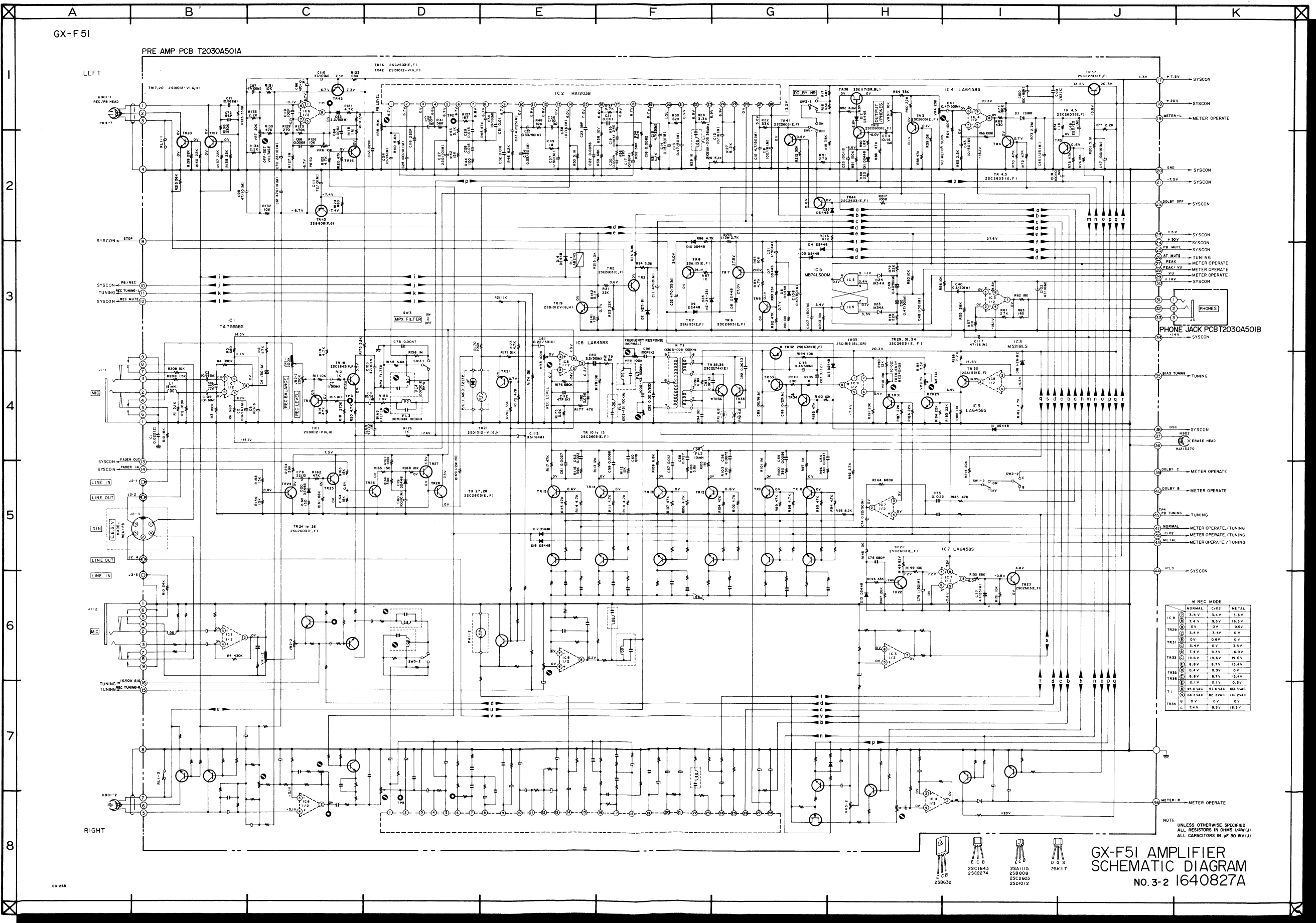

GX-F51

PRE AMP PCB T2030A501A

LEFT

RIGHT

M REC MODE			
IC 1	IC 2	IC 3	IC 4
0.4V	3.4V	3.4V	3.4V
3.4V	3.4V	3.4V	3.4V
0V	0V	0.6V	0V
0V	0.6V	0V	0V
3.4V	0V	3.4V	0V
7.4V	3.3V	16.0V	0V
16.5V	16.4V	16.8V	16.8V
6.8V	8.7V	15.4V	15.4V
0.4V	0.3V	0V	0V
6.8V	8.7V	15.4V	15.4V
0V	0.1V	0.3V	0.3V
45.0VAC	27.4VAC	108.3VAC	108.3VAC
64.3VAC	62.3VAC	141.2VAC	141.2VAC
0V	0V	0V	0V
3.4V	3.3V	16.3V	16.3V

NOTE: UNLESS OTHERWISE SPECIFIED ALL RESISTORS IN OHMS (1/4W/1%) ALL CAPACITORS IN μF (50 WV/1%)

GX-F51 AMPLIFIER SCHEMATIC DIAGRAM NO. 3-2 1640827A

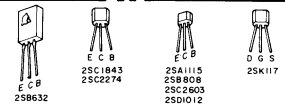

001265

GX-F51

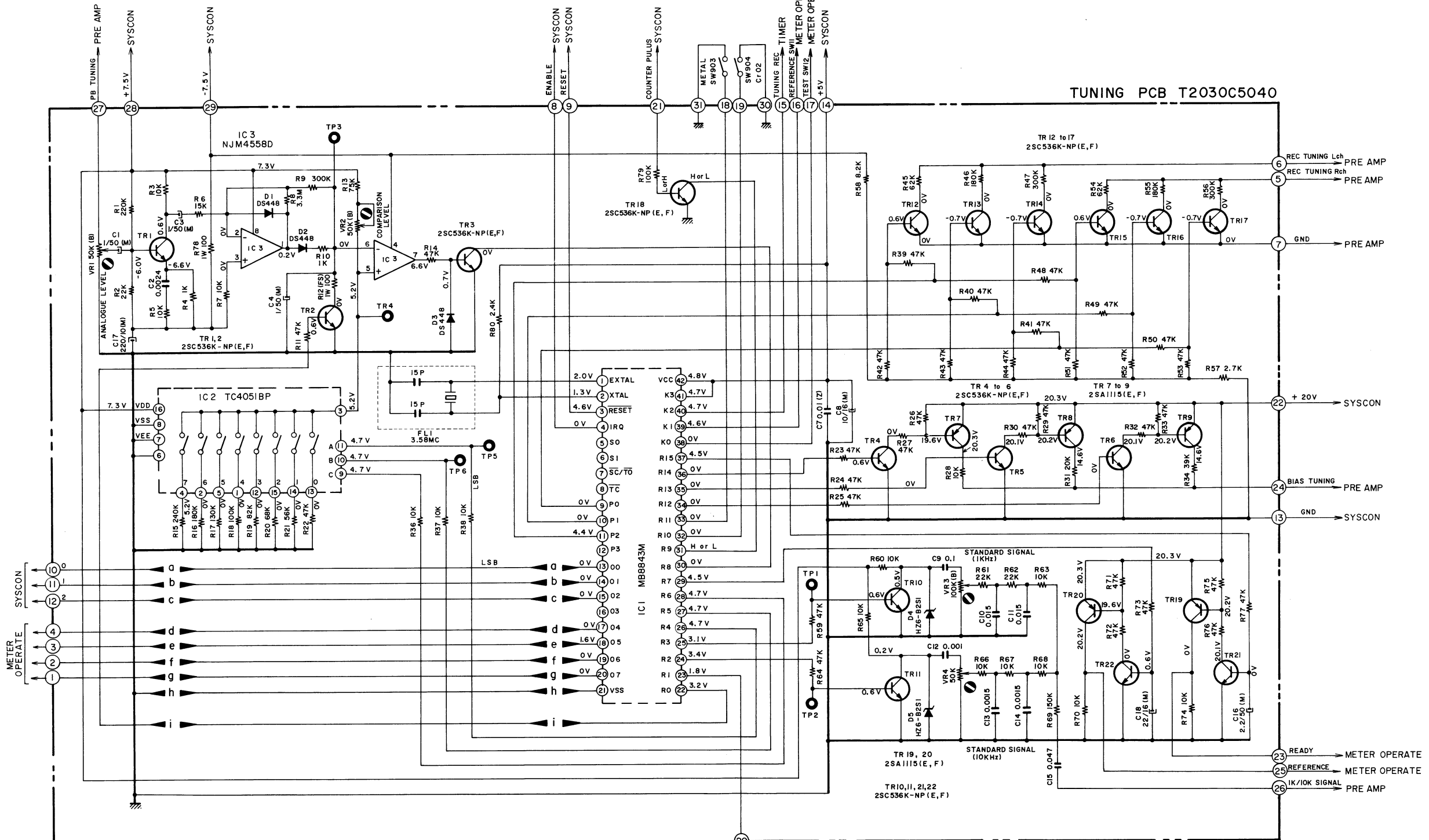

TUNING PCB T2030C5040

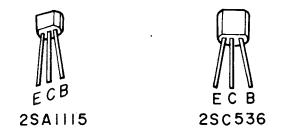

NOTE
UNLESS OTHERWISE SPECIFIED
ALL RESISTORS IN OHMS 1/4W(J)
ALL CAPACITORS IN μ F 50WV(J)

GX-F51 TUNING
SCHEMATIC DIAGRAM
NO. 3-3 1640828A

001266

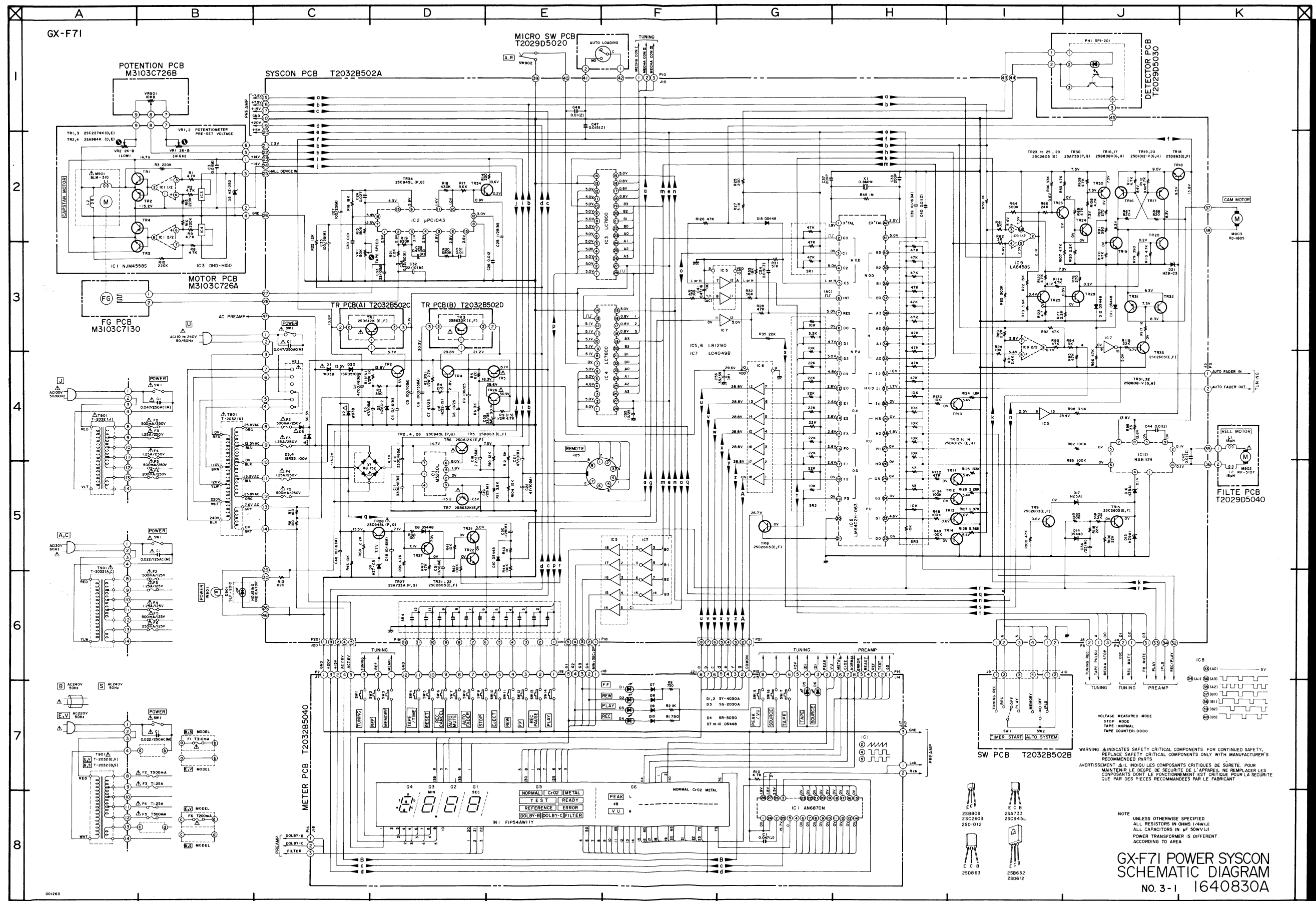

GX-F71 POWER SYSCON SCHEMATIC DIAGRAM No. 3-1 1640830A

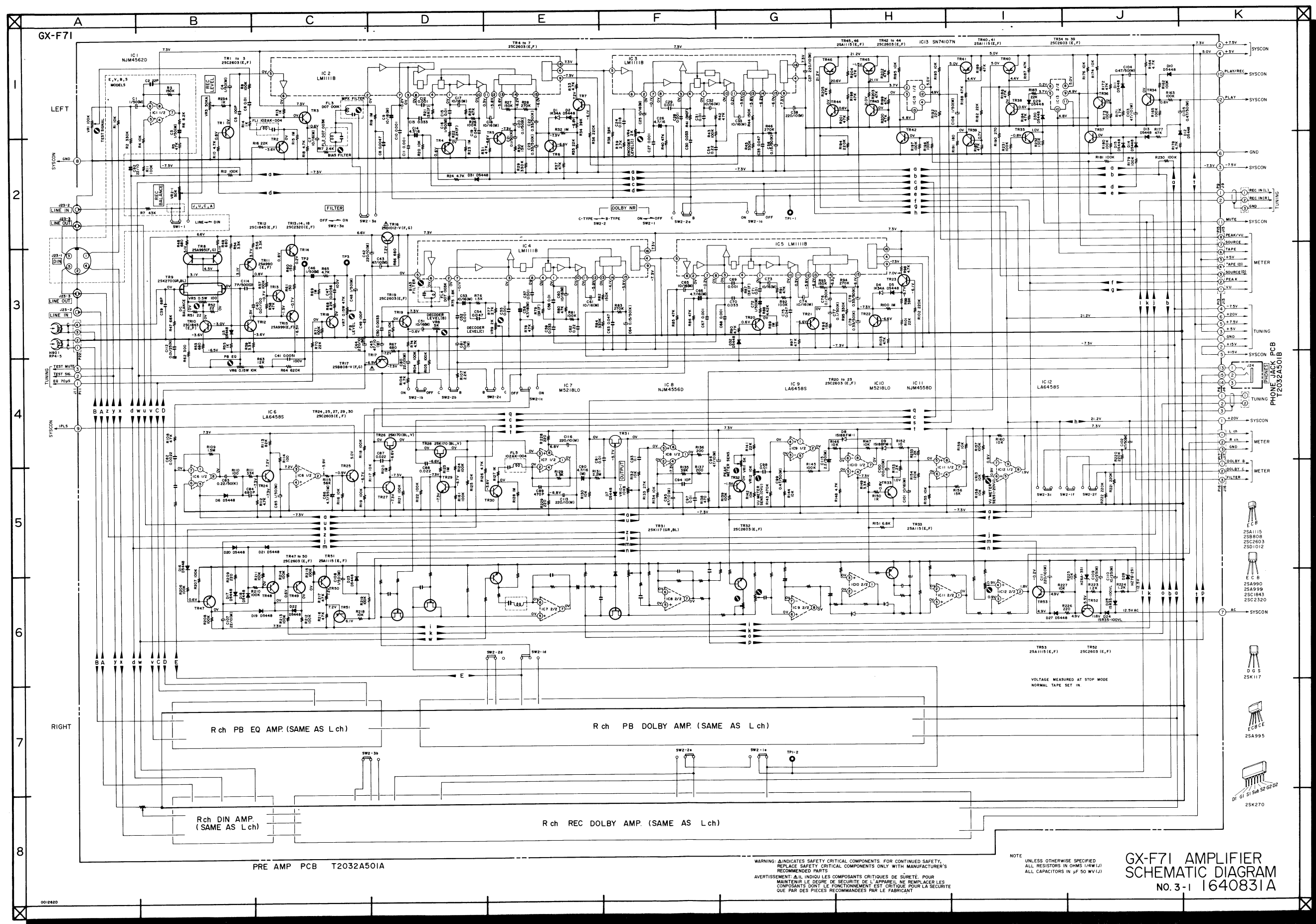

WARNING: Δ INDICATES SAFETY CRITICAL COMPONENTS. FOR CONTINUED SAFETY, REPLACE SAFETY CRITICAL COMPONENTS ONLY WITH MANUFACTURER'S RECOMMENDED PARTS.
 AVERTISSEMENT: Δ IL INDIQUE LES COMPOSANTS CRITIQUES DE SÛRETÉ. POUR MAINTENIR LE DEGRÉ DE SÛRETÉ DE L'APPAREIL, NE REMPLACER LES COMPOSANTS DONT LE FONCTIONNEMENT EST CRITIQUE POUR LA SÛRETÉ QUE PAR DES PIÈCES RECOMMANDÉES PAR LE FABRICANT.

NOTE: UNLESS OTHERWISE SPECIFIED, ALL RESISTORS IN OHMS (1/4W 1%) ALL CAPACITORS IN μF (50 WV 10%)

GX-F71 AMPLIFIER SCHEMATIC DIAGRAM
 NO. 3-1 1640831A

