

AKAI SERVICE MANUAL

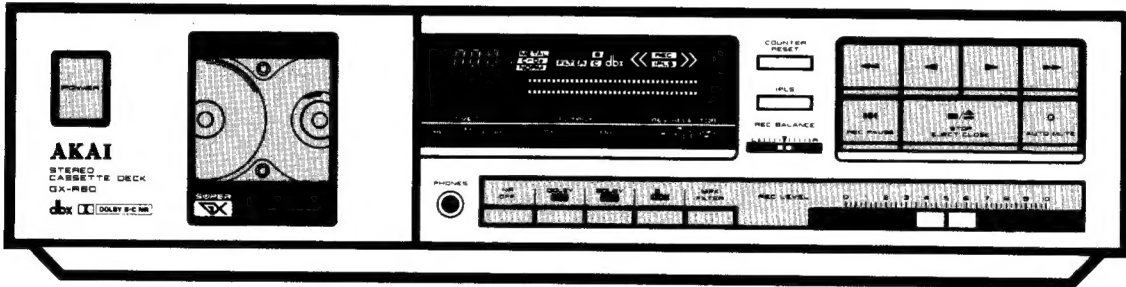

STEREO CASSETTE DECK

MODEL **GX-R60**

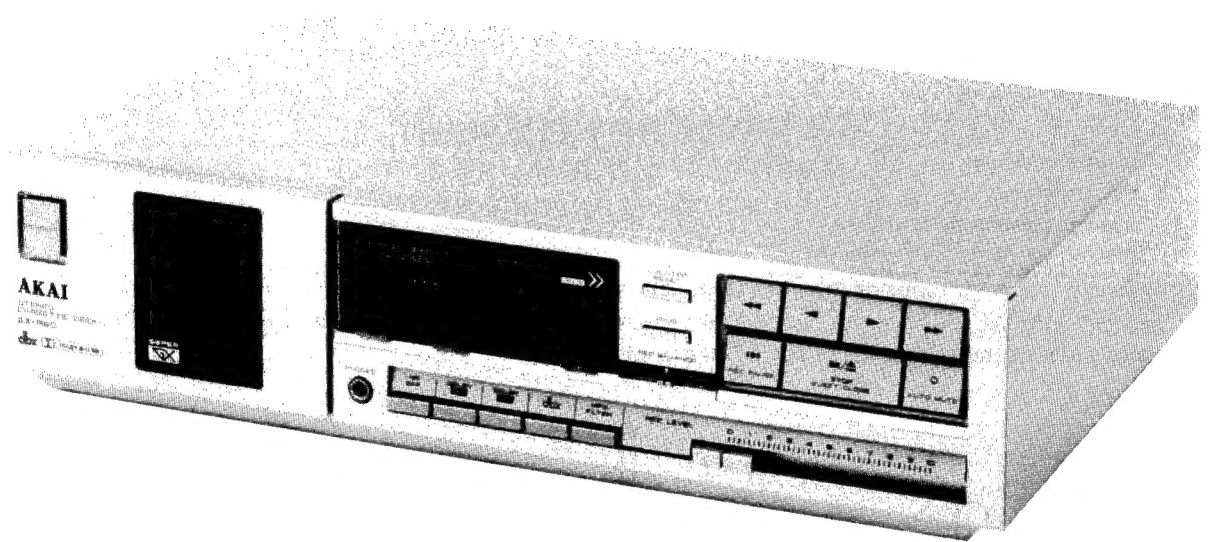

STEREO CASSETTE DECK

MODEL GX-R60

SECTION 1	SERVICE MANUAL	3
SECTION 2	PARTS LIST	19

SAFETY INSTRUCTIONS

SAFETY CHECK AFTER SERVICING

Confirm the specified insulation resistance between power cord plug prongs and externally exposed parts of the set is greater than 10 Mohms, but for equipment with external antenna terminals (tuner, receiver, etc.) and is intended for **C** or **A**, specified insulation resistance should be more than 2.2 Mohms (ground terminals, microphone jacks, headphone jacks, line-in-out jacks etc.)

PRECAUTIONS DURING SERVICING

1. Parts identified by the **Δ** symbol parts are critical for safety.
Replace only with parts number specified.
2. In addition to safety, other parts and assemblies are specified for conformance with such regulations as those applying to spurious radiation. These must also be replaced only with specified replacements.
Examples: RF converters, tuner units, antenna selector switches, RF cables, noise blocking capacitors, noise blocking filters, etc.
3. Use specified internal wiring. Note especially:
 - 1) Wires covered with PVC tubing
 - 2) Double insulated wires
 - 3) High voltage leads
4. Use specified insulating materials for hazardous live parts. Note especially:
 - 1) Insulation Tape
 - 2) PVC tubing
 - 3) Spacers (Insulating Barriers)
 - 4) Insulation sheets for transistors
 - 5) Plastic screws for fixing microswitch (especially in turntable)
5. When replacing AC primary side components (transformers, power cords, noise blocking capacitors, etc.), wrap ends of wires securely about the terminals before soldering.

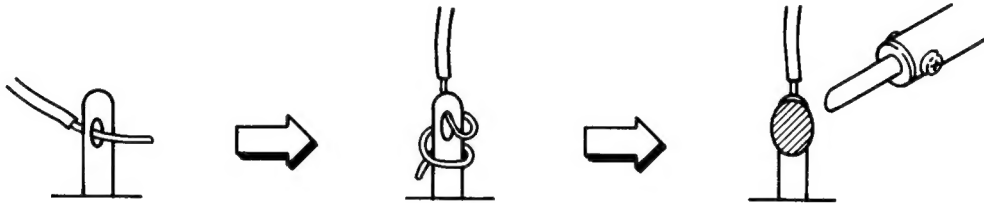

6. Observe that wires do not contact heat producing parts (heatsinks, oxide metal film resistors, fusible resistors, etc.).
7. Check that replaced wires do not contact sharp edged or pointed parts.
8. Also check areas surrounding repaired locations.
9. Use care that foreign objects (screws, solder droplets, etc.) do not remain inside the set.

VOLTAGE CONVERSION

Models for Canada, USA, Europe, UK and Australia are not equipped with this facility. Each machine is preset at the factory according to its destination, but some machines can be set to 110V, 120V, 220V, or 240V as required.

If your machine's voltage can be converted:

Before connecting the power cord, turn the VOLTAGE SELECTOR located on the rear panel with a screwdriver until the correct voltage is indicated.

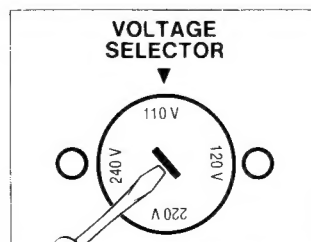

CYCLE CONVERSION

With DC Motors, Cycle Conversion is not necessary.

I. SPECIFICATIONS

TRACK SYSTEM	4 track 2 channel stereo
TAPE	Phillips type cassette
HEADS	Twin field super GX head for recording and playback × 1 Erase head × 1
MOTORS	Electronically speed controlled DC motor for capstan drive × 1 DC motor for reel and lid drive × 1 DC motor for cam drive × 1
WOW & FLUTTER	0.05% WRMS (JIS), 0.12% (DIN) ±0.07% W. Peak (EIAJ) for J-model
FREQUENCY RESPONSE	NORMAL CrO ₂ METAL
	20 Hz to 17,000 Hz ± 3 dB 20 Hz to 18,000 Hz ± 3 dB 20 Hz to 19,000 Hz ± 3 dB
S/N (METAL)	60 dB 59 dB (EIAJ) For J-Model Dolby B type NR switch ON: Improves up to 5 dB at 1 kHz, 10 dB above 5 kHz Dolby C type NR switch ON: Improves up to 15 dB at 500 Hz, 20 dB at 1 kHz to 10 kHz
DYNAMIC RANGE (dbx ON, 1 kHz)	110 dB
HARMONIC DISTORTION (METAL)	Less than 0.8% 0.8% (EIAJ) For J-model
INPUT SENSITIVITY/IMPEDANCE	LINE 70 mV/47 kohms
OUTPUT SENSITIVITY/IMPEDANCE	LINE HEADPHONES 388 mV/1 kohms 1.3 mW (8 ohms)/83 ohms
POWER REQUIREMENTS	100V, 50/60 Hz for JPN 120V, 60 Hz for USA & Canada 220V, 50 Hz for Europe except UK 240V, 50 Hz for UK & Australia 110V/120V/220V/240V, 50 Hz/60 Hz convertible for other countries
POWER CONSUMPTION	17W for J-model
DIMENSIONS	440 (W) × 105 (H) × 280 (D) mm (17.3 × 4.1 × 11.0 inches)
WEIGHT	5.0 kg (11.0 lbs)

* For improvement purposes, specifications and design are subject to change without notice.

* Noise reduction manufactured under license from Dolby Laboratories Licensing Corporation. "Dolby" and double-D symbol are trade marks of Dolby Laboratories Licensing Corporation.

II. DISMANTLING OF UNIT

In case of trouble, etc. necessitating dismantling, please dismantle in the order shown in the photographs. Reassemble in reverse order.

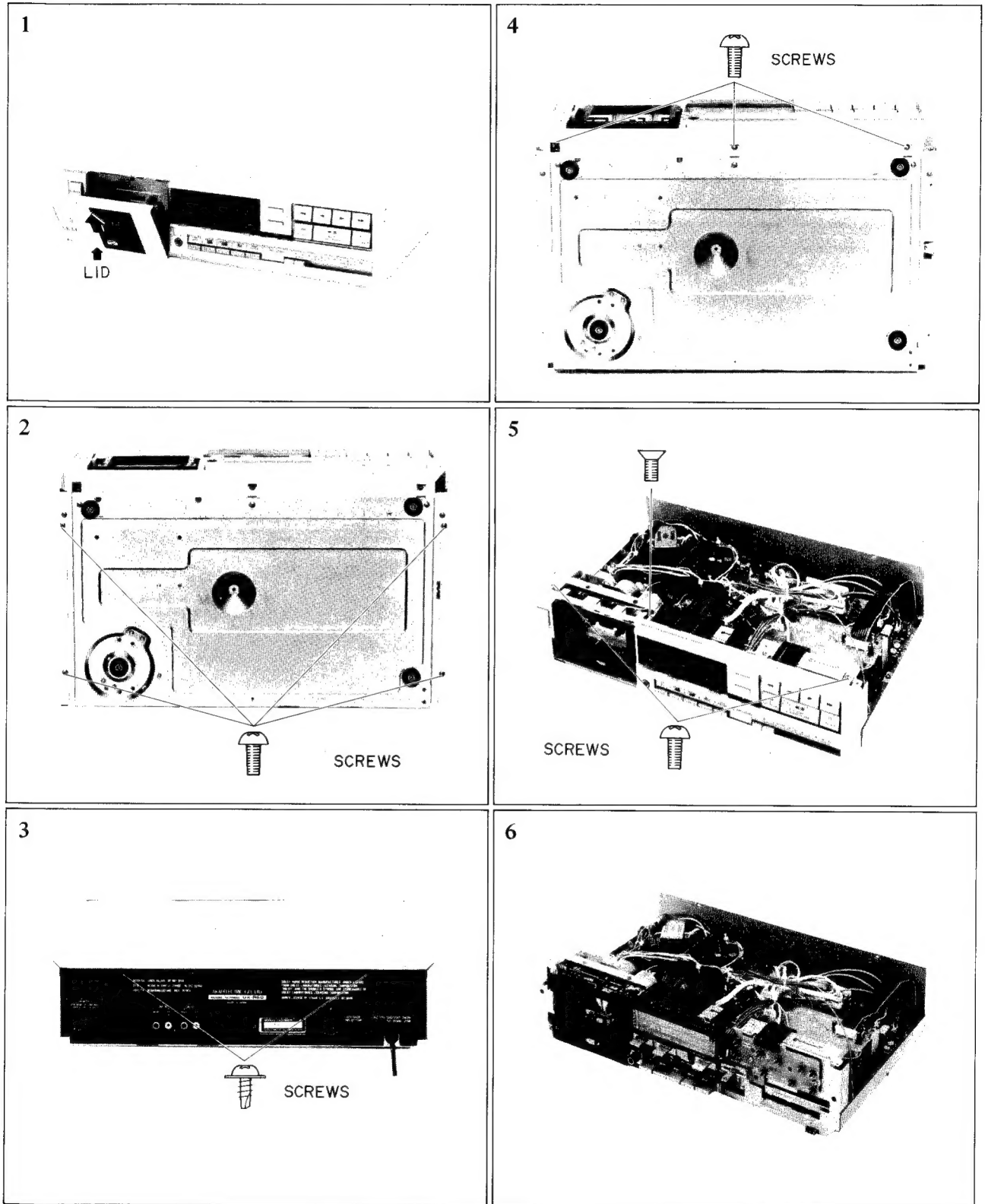

III. CONTROLS

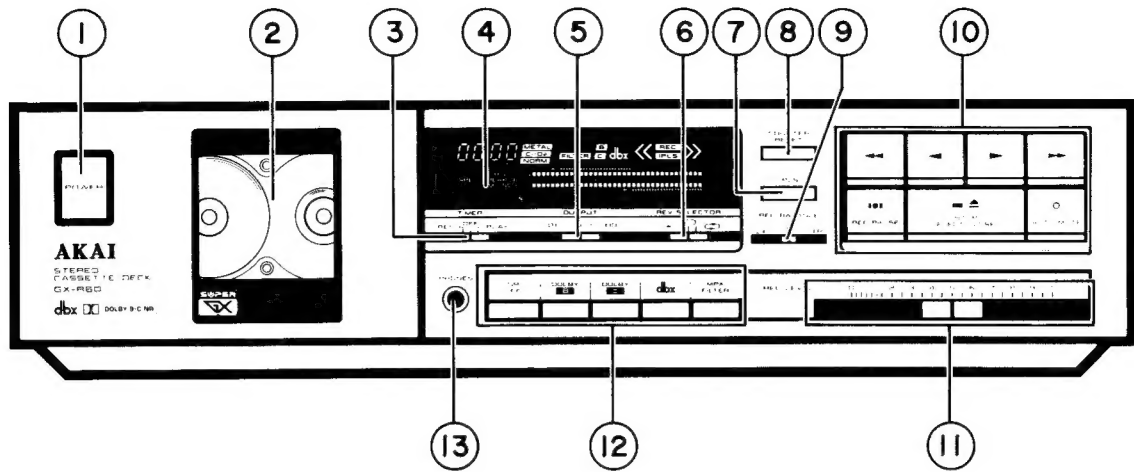

Fig. 3-1

1. POWER BUTTON
2. CASSETTE HOLDER AND CASSETTE LID
3. TIMER CONTROL
4. FL DISPLAY
5. OUT PUT CONTROL
6. REVERSE CONTROL
7. IPLS MODE SELECTOR
8. COUNTER RESET
9. REC BALANCE
10. TAPE TRANSPORT BUTTONS
11. REC LEVEL CONTROL
12. NOISE REDUCTION CONTROL
13. PHONES JACK

IV. PRINCIPAL PARTS LOCATION

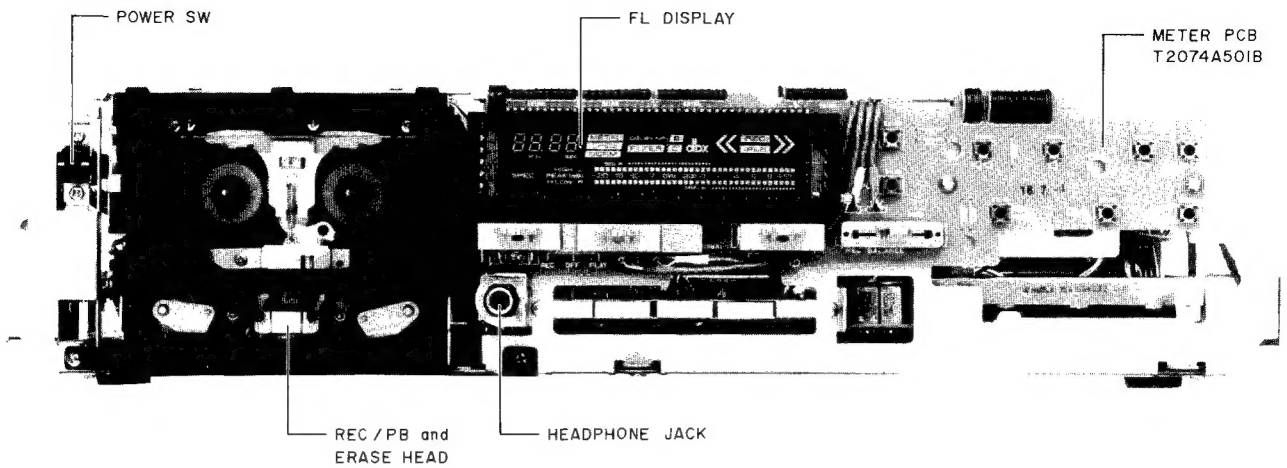

Fig. 4-1 Front View

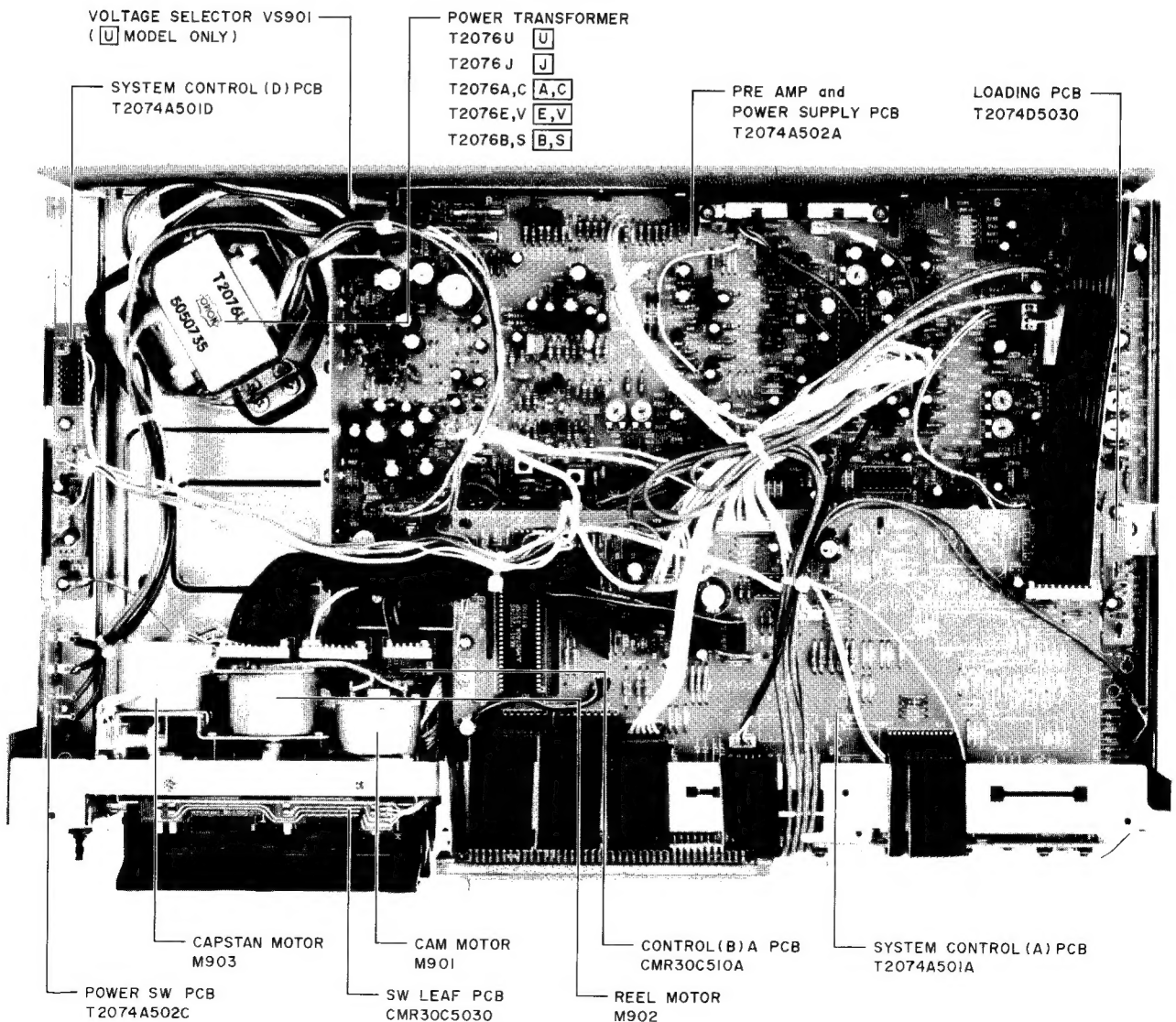

Fig. 4-2 Top View

V. MECHANISM EXPLANATION OF EACH MODE

The operating functions are controlled by the rotary encoder. The main cam wheel is rotated to the set point. Here, we shall explain the mechanism functions:

The main cam wheel is driven by the cam motor through cam gears (B) and (C).

5-1. DIRECT OPERATIONS RESULTING BY MOVEMENTS OF THE MAIN GEAR WHEEL

1) Pinch roller (Refer to Fig. 5-1)

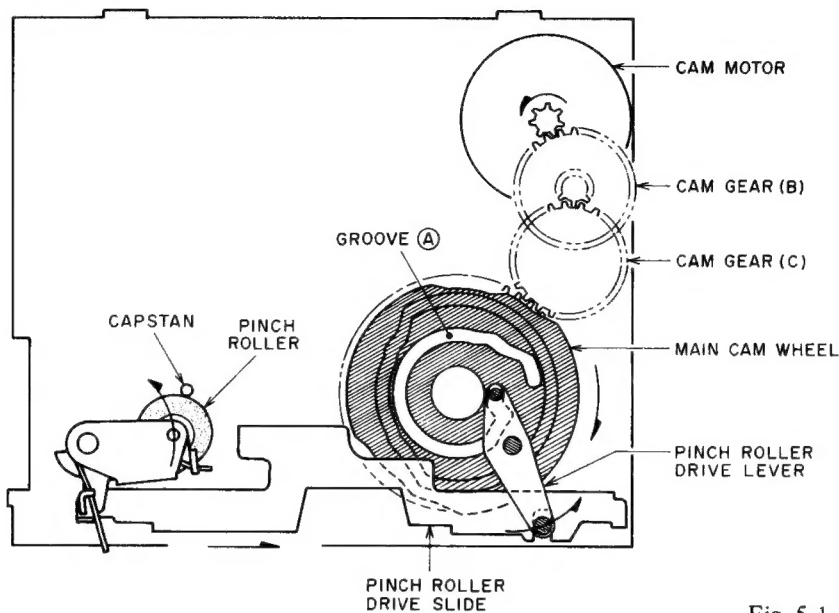

Fig. 5-1

The main cam wheel's groove (A) rived the pinch roller drive lever, pinch roller drive slide and the pinch roller.

When the pinch roller drive lever moves in the right direction, the reverse side's pinch roller moves to the left direction and the capstan contacts to the forward side's pinch roller.

2) Head base plate (Refer to Fig. 5-2)

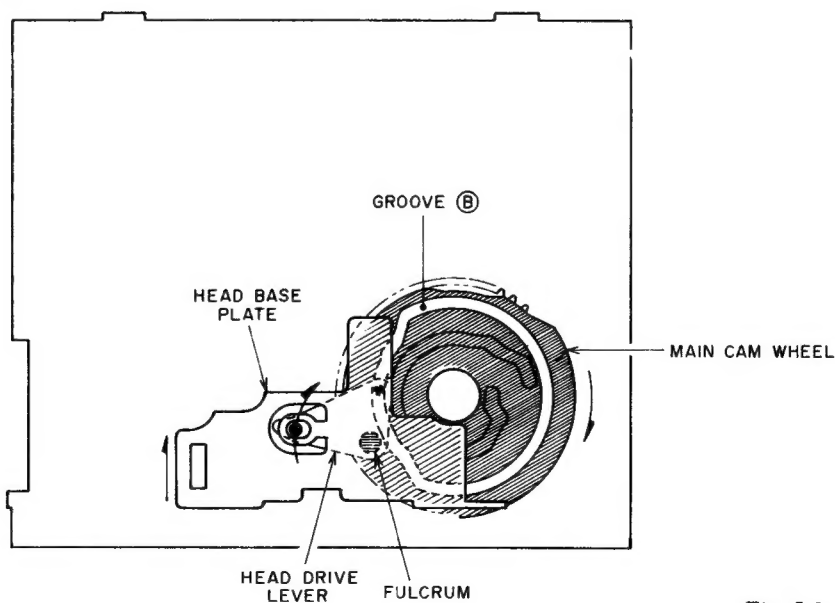

Fig. 5-2

The main cam wheel's groove (B) drives the head drive lever and the head base plate. When the head

base plate moves vertically, the REC/PB combination head moves vertically.

3) Head Rotation (Refer to Fig. 5-3)

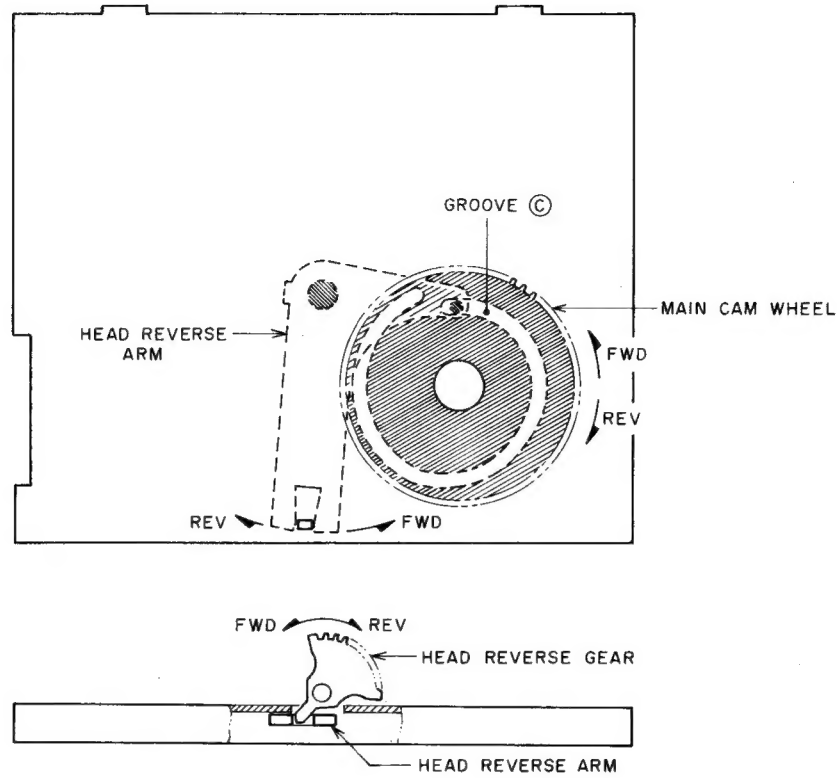

Fig. 5-3

The main cam wheel's groove © drives the head reverse arm and the head reverse gear.
The head rotates when the head reverse gear move.

In the reverse mode, the head moves from left to right.
In FWD mode, the head moves from right to left.

4) Brake and Reel Base (Refer to Figs. 5-4 to 5-7)

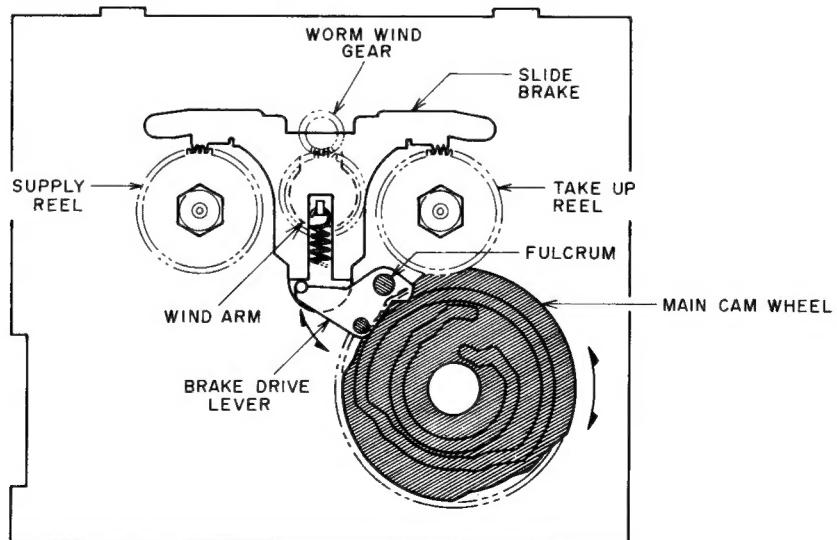

Fig. 5-4

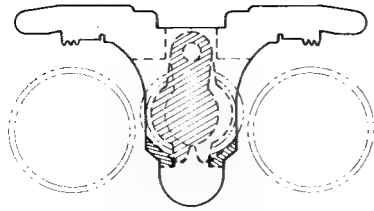

Fig. 5-5

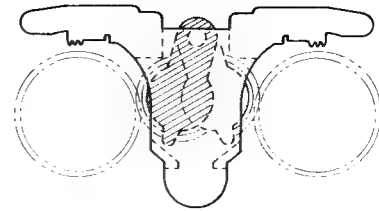

Fig. 5-6

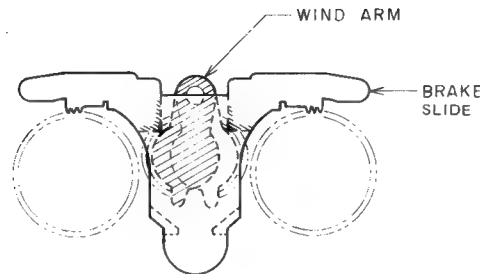

Fig. 5-7

The main cam wheel's external surface drives the brake drive lever and the slide brake.
The slide brake's position rotates the brake and the reel.

- a. The slide brake at bottom position (Refer to Fig. 5-5)
Brake is applied on the reel (supply and take-up).
Wind arm is released from the reel. (In stop condition).
- b. The slide brake at top position (Refer to Fig. 5-6)
The brake is free from the reel. Wind arm is released from the reel. (ejected condition).
- c. The slide brake at the middle position (Refer to Fig. 5-7)
The brake is not applied on the reel.
The wind arm and the reel base come into contact.
The reel motor rotates the worm wind gear. The wind arm swings direction of left and right and rotates the reel base. (In play, FF, rewind and IPLS condition).

5-2. EJECT/LOADING OPERATION (Refer to Figs. 5-8 and 5-9)

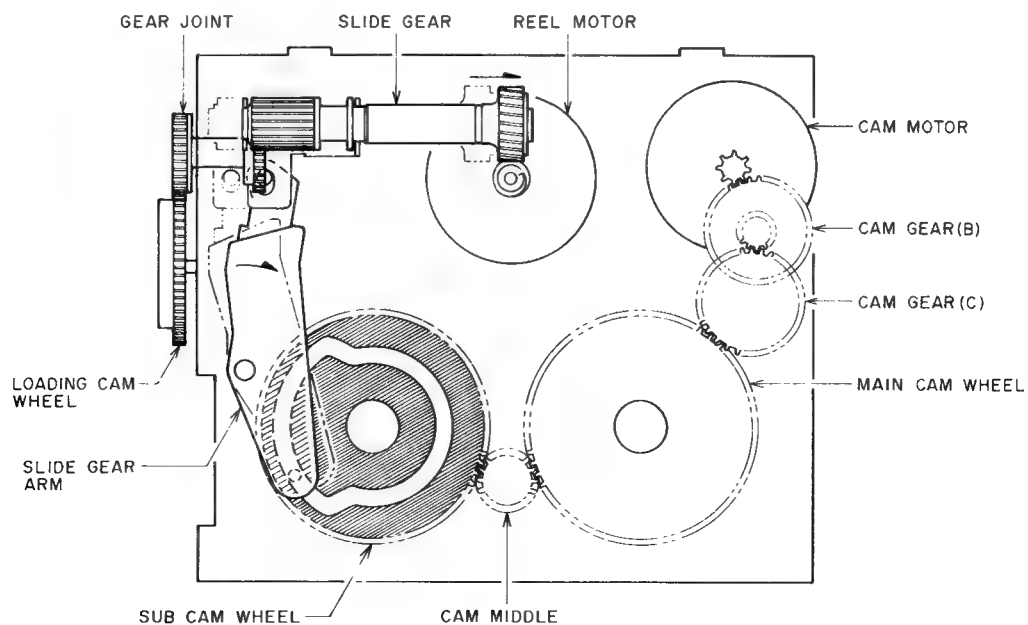

Fig. 5-8

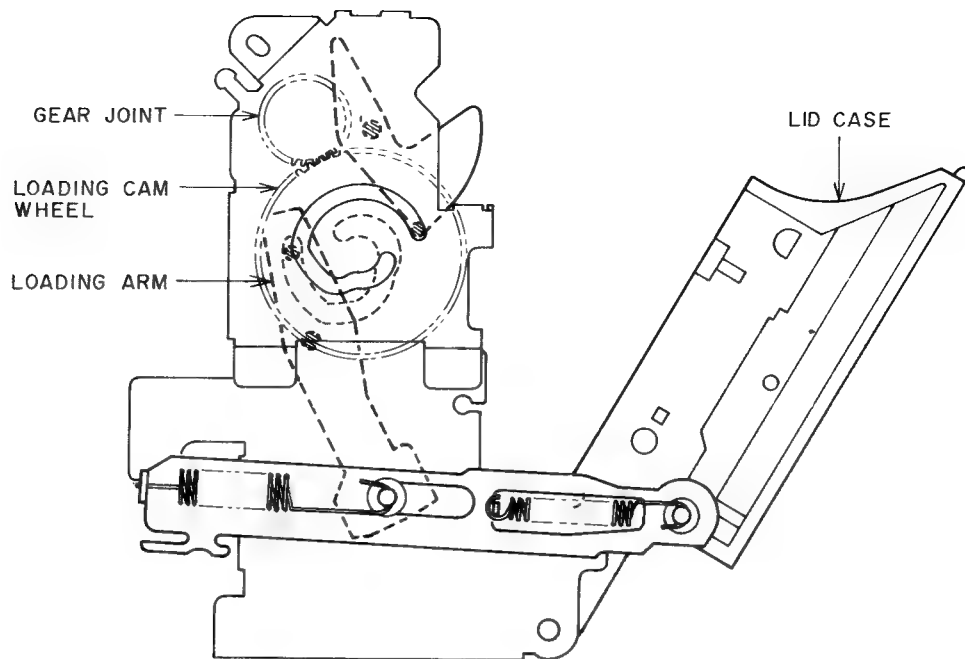

Fig. 5-9

The cam motor drives the cam gear B and C, the main gear, the cam middle and the sub-cam gear.

The slide gear arm and the slide gear move by rotating the sub-cam gear. The slide gear shifts from left to right during eject leading. (Front view).

It contacts with the worm wind gear and rotates the slide gear. The opening/closing of the lid case functions by the reel motor, worm wind gear, gear joint and the loading cam wheel. This in turn drives the loading arm and opens/closes the lid case. The slide gear contacts to the worm wind gear only at eject/loading.

VI. FIXING PROCEDURES FOR CAM WHEEL AND ROTARY ENCODE PCB

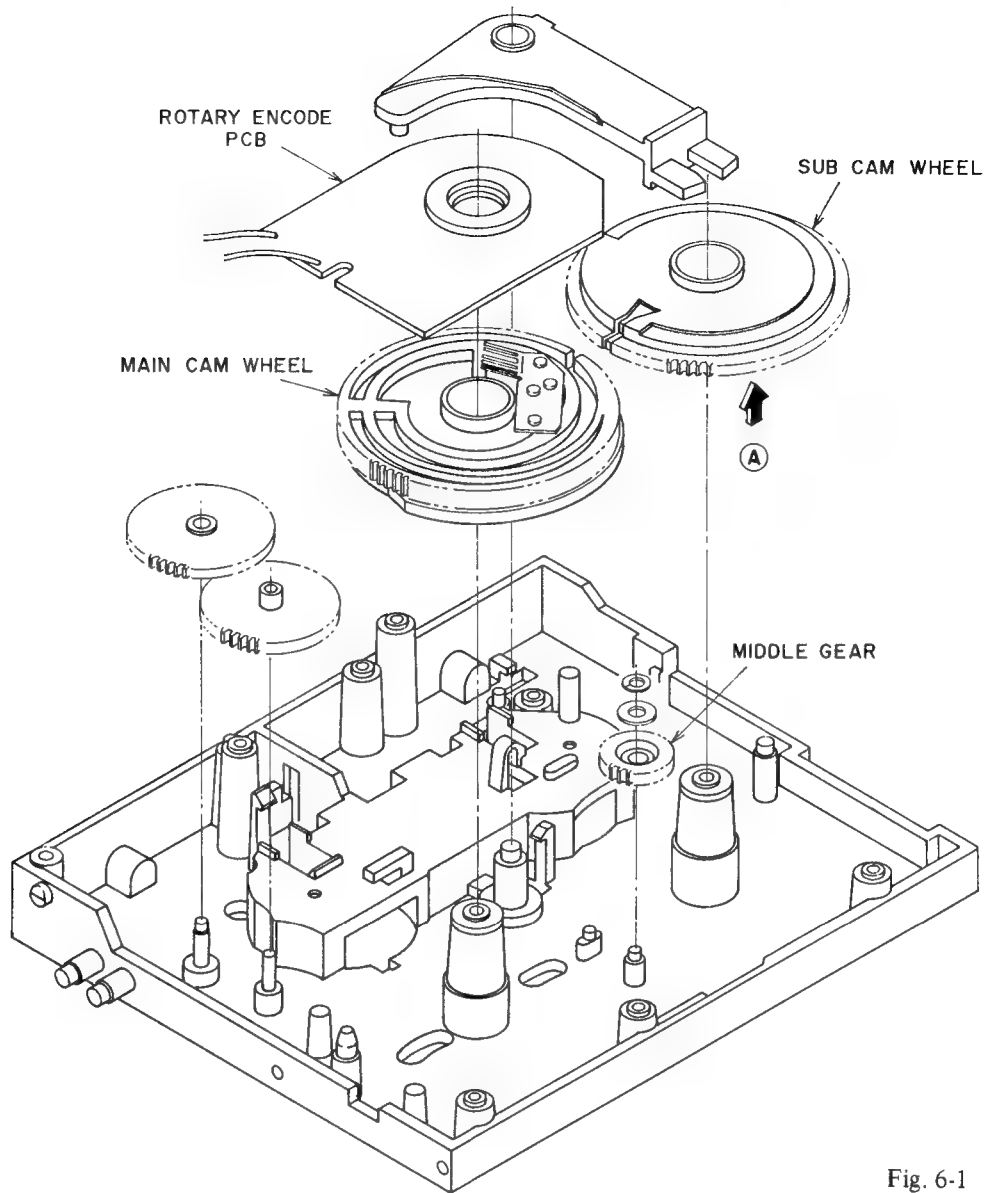

Fig. 6-1

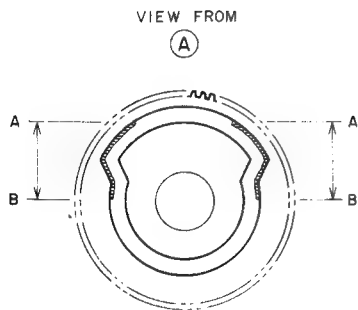

Fig. 6-2

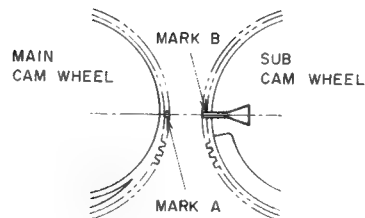

Fig. 6-3

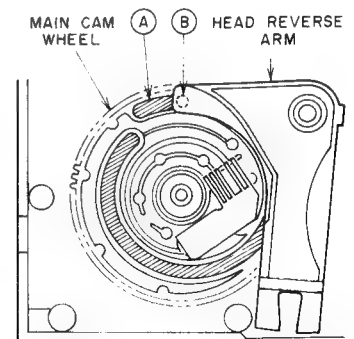

Fig. 6-4

- 1) Lock at SUB CAM WHEEL from direction **A** (Fig. 6-1) and apply grease to areas A to B (the side of the groove shaded with oblique lines) as in Fig. 6-2.
- 2) Align marks (A) and (B) on MAIN CAM WHEEL and SUB CAM WHEEL and fix them on capstan holder as shown in Fig. 6-3.
- 3) Make sure that the marked positions on MAIN CAM WHEEL and SUB CAM WHEEL do not move, then fix MIDDLE GEAR on chassis.
- 4) Insert the head Reverse arm pin **B** (see Fig. 6-1) into groove **A** in MAIN CAM WHEEL as in Fig. 6-4.
- 5) When fixing the rotary encode PCB, check the pattern side is facing MAIN CAM WHEEL.

VII. MECHANICAL ADJUSTMENT

7-1. PINCH ROLLER PRESSURE MEASUREMENT

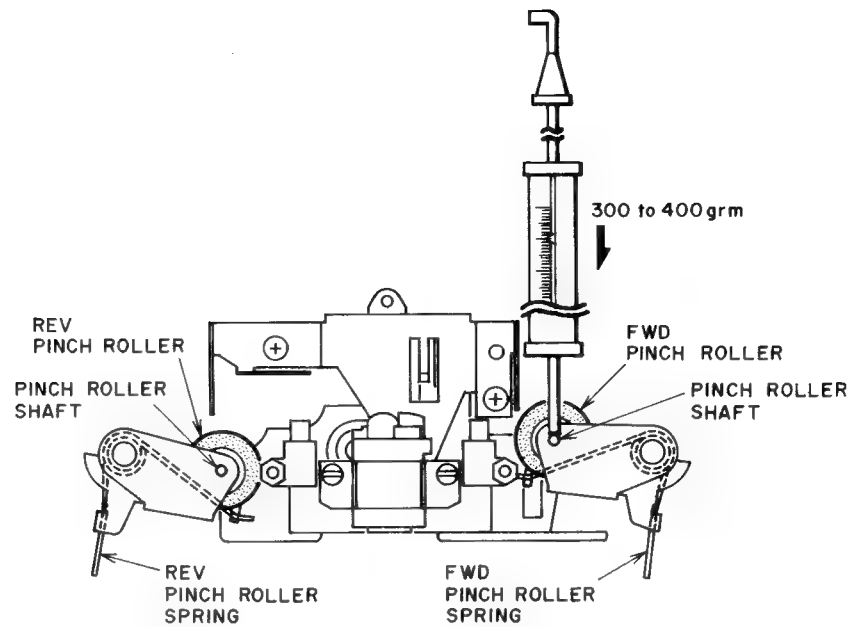

Fig. 7-1

Put in FWD PLAY Mode, Push Pinch roller shaft down with the spring gauge, and push the pinch roller 1 to 2 mm away from the capstan and release slowly. Read the spring gauge at the moment the pinch roller

touches the capstan and begins to rotate. Specified contact pressure measurement is 300 to 400 grams. If the correct measurement is not obtained, replace the pinch roller spring. Do the same for the reverse side.

7-2. WINDING TORQUE MEASUREMENT IN EACH MODE

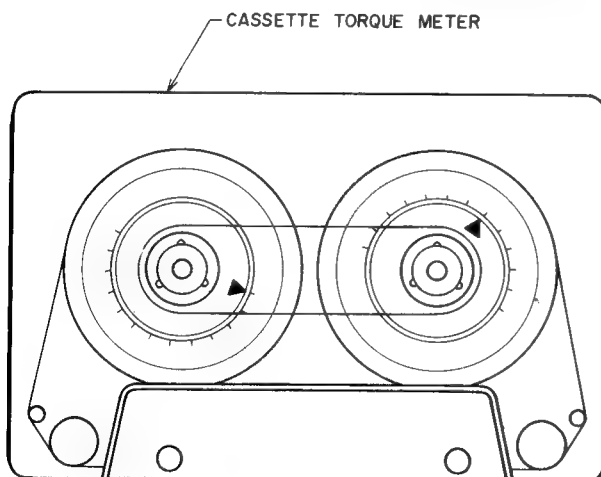

Fig. 7-2

Insert a cassette torque meter (AJ-751179) and measure in each mode, for Fast Forward and Rewind, measure at the end of the tape when the tape has stopped running.

Forward or Reverse mode

Take up Torque: 40 ± 15 g-cm (25 to 55 g-cm)

Back Tension Torque: 3^{+2}_{-1} g-cm (2 to 5 g-cm)

Fast Forward or Rewind mode

Take up Torque: 120^{+130}_{-50} g-cm (70 to 250 g-cm)

7-3. TAPE SPEED ADJUSTMENT

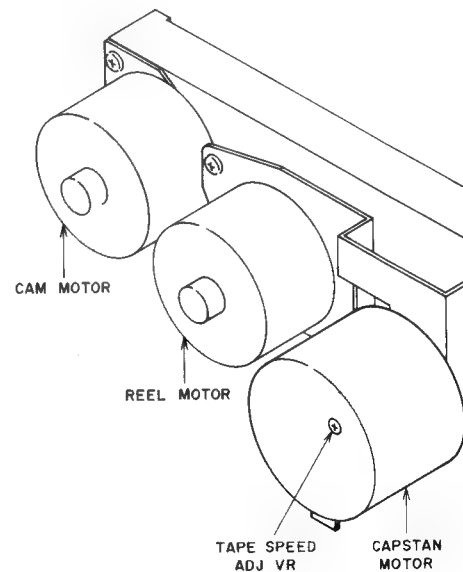

Fig. 7-3

- 1) Connect a frequency counter to Line output terminal.
- 2) Play back a 3150 Hz pre-recorded Test Tape (AT-751263) and adjust the Tape Speed Adjustment Variable Resistor to obtain a tape speed of 3150 Hz \pm 30 Hz.

VIII. HEAD ADJUSTMENT

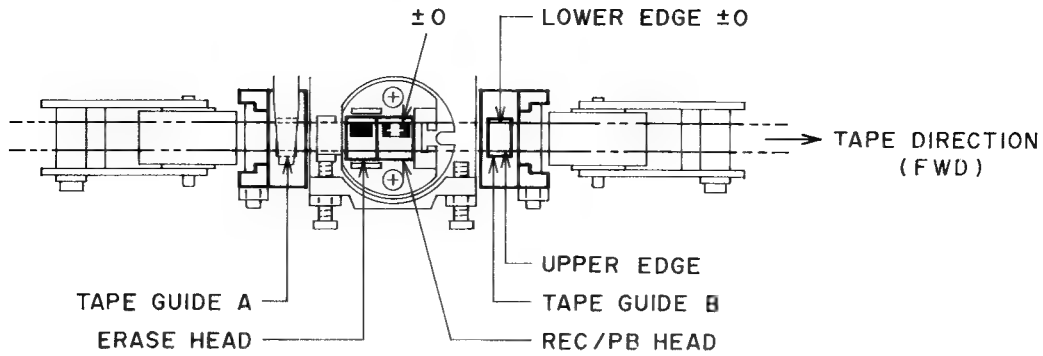

Fig. 8-1

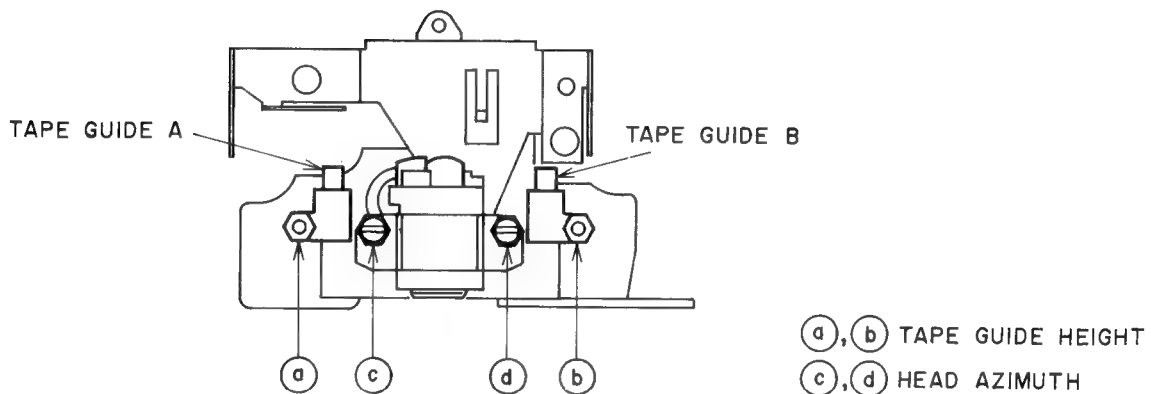

Fig. 8-2

8-1. TAPE GUIDE HEIGHT ADJUSTMENT

- 1) Use the mirror tape (AJ-751178) and adjust the tape guide height with turning the tape guide height adjustment nuts (a) and (b) so that when in FWD Play mode, the tape edge and the head edge match as in Fig. 8-1.
- 2) Play back the 315 Hz OVU (AT-750773) tape and adjust the tape guide height adjustment nuts (a) and (b) so that the difference in level between Lch on FWD and Lch on REV is within 0.5 dBm.
- 3) Play back the 1 kHz 4 Track (AT-750775) tape and adjust the tape guide height adjustment nuts (a) and (b) so that the difference in level between this and the 315 Hz tape in 2) is within 2.0 dBm.
- 4) Repeat 2) and 3) until the optimum condition is achieved.
- 5) Use the mirror tape and check that the tape runs smoothly (The tape edge should not catch on the tape guide and should not curl.) If the tape edge catches on the tape guide, move the tape guide height adjustment nuts (a) and (b) slowly until the tape runs smoothly.
- 6) After adjustment, check 2) and 3) again.

- 7) After adjustment, paintlock the tape guide height adjustment nuts (a) and (b).

8-2. HEAD HEIGHT ADJUSTMENT

No adjustment is required for the height of the head itself. Follow the tape guide height adjustment procedures when the head is replaced and head height adjustment is required.

8-3. REC/PB HEAD AZIMUTH ALIGNMENT ADJUSTMENT

Play back the 10 kHz pre-recorded test tape (AT-750778) for head azimuth adjustment and adjust screw (c) for the FWD direction and screw (d) for the REV direction, so that the level on both channels is at maximum.

NOTES:

1. Be sure to clean the heads prior to head adjustment.
2. Be careful not to use a magnetized driver or other magnetized tools in the vicinity of the heads.
3. Be sure to demagnetize the heads with a head demagnetizer before and after head adjustment.

IX. ELECTRICAL ADJUSTMENT

9-1. QUICK REVERSE SENSITIVITY ADJUSTMENT

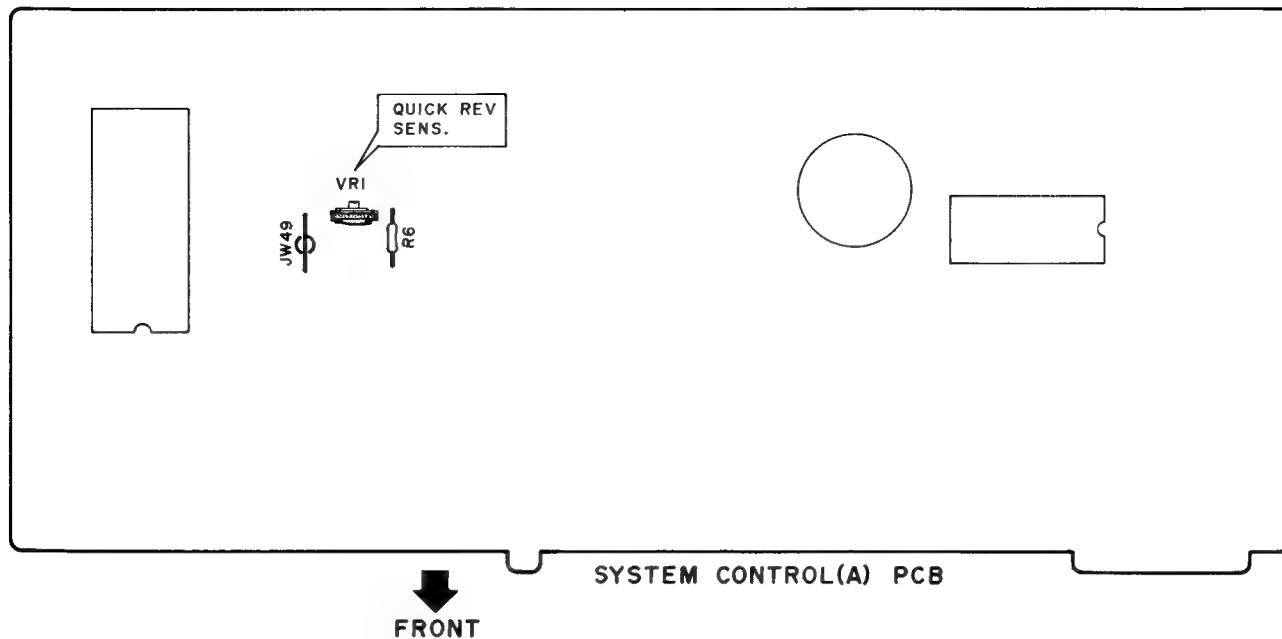

Fig. 9-1

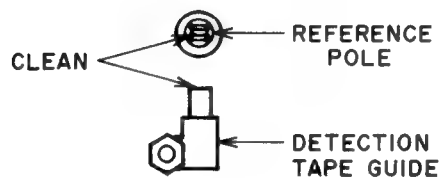

Fig. 9-2

- 1) Make a tapeless cassette pack by removing the tape from the white colored test tape.
- 2) Connect a Digital Voltmeter between JW49 and GND.
- 3) Using the tapeless cassette pack, adjust VR1 so that the digital voltmeter reads $12 \pm 0.3V$ DC at FWD play mode.
- 4) If the digital voltmeter reading is not increase to 12V DC at VR1 maximum. Remove the Resistor R6 (100K ohms) from SYSCON PC Board, and adjust VR1 as the same manner in item 3).

NOTE: Clean the reference pole and the Detection tape guide before adjustment. (Refer to Fig. 9-2).

9-2. PRE AMP ADJUSTMENT

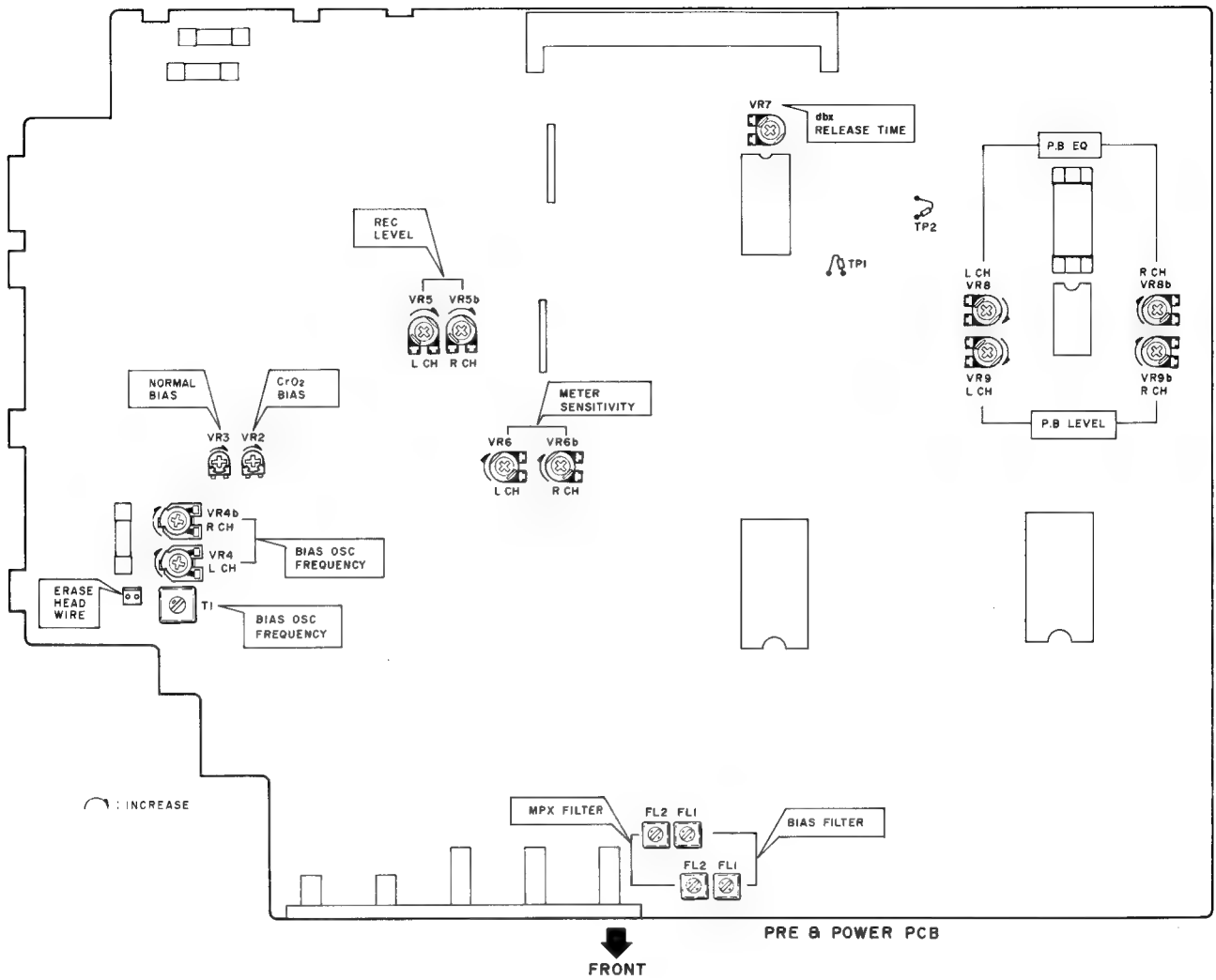

Fig. 9-3

Step	Adjustment Item	Test Tape & Supply Signal	Mode	Adjustment Part	Result	Remarks
1	P.B LEVEL	315 Hz	FWD P.B	VR9	-6.0 ± 0.2 dBm	
			REV P.B	NONE	-6.0 ± 0.2 dBm	Confirmation
2	P.B EQ	10 kHz -15 dBm	FWD P.B	VR8	-21.0 ± 0.3 dBm	
			REV P.B	NONE	-21.0 ± 0.3 dBm	Confirmation
3	BIAS OSC FREQUENCY	METAL BLANK TAPE	REC/P.B	T1	$100\text{kHz} \pm 1.5\text{kHz}$	Connect a Frequency Counter to ERASE HEAD WIRE.
4	NORMAL BIAS	NORMAL BLANK TAPE 1 kHz, 10 kHz -26.0 dBm	REC/P.B	VR4	1 kHz, 10 kHz Flat ± 0.5 dBm	

Step	Adjustment Item	Test Tape & Supply Signal	Mode	Adjustment Part	Result	Remarks
5	CrO ₂ BIAS	CrO ₂ BLANK TAPE 1 kHz, 10 kHz -26.0 dBm	REC/P.B	VR3	1 kHz, 10 kHz Flat ±0.5 dBm	
6	METAL BIAS	METAL BLANK TAPE 1 kHz, 10 kHz -26.0 dBm	REC/P.B	VR2	1 kHz, 10 kHz Flat ±0.5 dBm	
7	REC LEVEL	NORMAL BLANK TAPE 315 Hz -6.0 dBm	REC/P.B	VR5	-6.0 ± 0.5 dBm	
8	METER SENSITIVITY	BLANK TAPE 1 kHz -6.0 dBm	REC/PAUSE	VR6	0VU indication	
9	dbx Release time	BLANK TAPE 1 kHz -6.0 dBm	REC/PAUSE	VR7	15.0 ± 0.2 mV	Connect a Digital Voltmeter between TP1 and TP2.
10	BIAS LEAK (SEE NOTE 2)	NORMAL BLANK TAPE NO SIGNAL	REC/P.B	FL1	Less than -40 dBm	
11	MPX FILTER (SEE NOTE 2)	19 kHz -6.0 dBm	REC/PAUSE	FL2	Less than -30 dBm	MPX FILTER SWITCH ON

- NOTES:**
1. Set to the DOLBY-NR switch to OFF position for all the adjustments.
 2. The adjustments in step 10 and 11 are not needed in normal condition, nor when FL1, FL2 are replaced with a new one.
However, follow the instructions in steps 10 and 11, incase they (ON PRE & POWER PCB) are misadjust.
 3. Use the following cassette measuring tapes.

NORMAL TAPE : MAXELL UDI C-60
 CrO₂ TAPE : TDK SA C-60
 METAL TAPE : TDK MA C-60

X. PC BOARD TITLES AND IDENTIFICATION NUMBERS

PC Board Title		P.C Board Number
SYSTEM CONTROL (A)	PC BOARD	T2074A501A
METER	PC BOARD	T2074A501B
SYSTEM CONTROL (D)	PC BOARD	T2074A501D
PRE AMP & POWER SUPPLY	PC BOARD	T2074A502A
HEADPHONE	PC BOARD	T2-74A502B
POWER SW	PC BOARD	T2074A502C
LOADING	PC BOARD	T2074D5030
ROTARY ENCODER	PC BOARD	CMR30B5010
CONTROL (B) A	PC BOARD	CMR30C510A
CONTROL (B) B	PC BOARD	CMR30C510B
LEAF SW	PC BOARD	CMR30C5030

SECTION 2

PARTS LIST

TABLE OF CONTENTS

RECOMMENDED SPARE PARTS	21
1. MECHA CMR33 BLOCK (1)	22
2. MECHA CMR33 BLOCK (2)	24
3. PC BOARD BLOCK	26
4. PRE AMP & POWER SUPPLY PC BOARD	26
5. SYSTEM CONTROL (A) PC BOARD	27
5A. LOADING PC BOARD	27
6. SYSTEM CONTROL (D) PC BOARD	27
7. METER PC BOARD	28
8. CONTROL (B) A PC BOARD	28
9. FILTER PC BOARD	28
10. HEAD PHONE PC BOARD	28
11. CONTROL (B) B PC BOARD	28
12. POWER SW PC BOARD	28
13. ASSEMBLY BLOCK	28
14. FINAL ASSEMBLY BLOCK	30
INDEX	31

Resistors and Capacitors which are not listed in this parts list, please refer to COMMON LIST FOR SERVICE PARTS.

ATTENTION

1. When placing an order for parts, be sure to list the parts no., model no., and description of each part. If any of this information is omitted, there are instances in which parts cannot be shipped or the wrong parts will be delivered.
2. Please be careful not to make a mistake in the parts no. If the parts no. is in error, a part different from the one ordered may be delivered.
3. Because part numbers and part definitions and supply in the Preliminary Parts List may have been the subject of changes, please use this parts list for all future reference.

HOW TO USE THIS PARTS LIST

1. This Parts List shows those parts which are considered necessary for repairs. Other parts, such as resistors and capacitors, are shown in the "Common List for Service Parts" from which these parts should be selected and parts.
2. The Recommended Spare Parts List shows those parts in the Parts List which are considered particularly important for service.
3. Parts not shown in the Parts List and "Common List for Service Parts" will not in principle be supplied.
4. How to read the parts list
 - a) Mechanism Block
 - b) P.C Board Block

2. HEAD BASE BLOCK

REF. NO.	PART NO.	DESCRIPTION
2-1x	BH-T2023A320A	HEAD BASE BLOCK GX-F66R
2-2	HP-H2206A010A	HEAD R/P PR4-8FU C
2-3	ZS-477876	PAN20x03STL CMT
2-4	ZS-536488	BID20x08STL CMT
2-5	ZG-402895	CS ANGLE ADJUST SPRING

SP (Service Parts) Classification
 A small "x" indicates the inability to show that particular part in the Photo or Illustration.
 This number corresponds with the individual parts index number in that figure
 This number corresponds with the Figure Number

6. SYS. CON. P C BOARD BLOCK

REF. NO.	PART NO.	DESCRIPTION
6-1	BA-T2034A070A	PC SYS CON BLK GX-F44R
6-IC1	EI-324536	IC HD14049BP
6-IC2	EI-336801	IC MB8841-564M
6-IC3	EI-331661	IC SN7405N
6-IC4	EI-336725	IC M54527P
6-TR1to4	ET-200985	TR 2SC2603 F,G
6-TR5to28	ET-554657	TR 2SA733A P,Q
6-D1	ED-318292	D SILICON H 1S2473T-77 T26
6-D2to4	ED-308952	D GERMA V 1K34A-LR F07
6-D5to10	ED-318292	D SILICON H 1S2473T-77 T26
6-X1	EI-318384	OSC X'TAL NC-18C 3.579545MHZ

SP (Service Parts) Classification
 These reference symbols correspond with component symbols in the Schematic Diagrams.

5. The kind of part and its installation position can both be determined by the Part Number. To determine where a part number is listed, utilize the Parts Index at the end of the Parts List. It is necessary first of all to find the Part Number. This can be accomplished by using the Reference Number listed at the right of the part number in the Parts Index.

WARNING

⚠ INDICATES SAFETY CRITICAL COMPONENTS. FOR CONTINUED SAFETY, REPLACE SAFETY CRITICAL COMPONENTS ONLY WITH MANUFACTURE'S RECOMMENDED PARTS

AVERTISSEMENT

⚠ IL INDIQUE LES COMPOSANTS CRITIQUES DE SÉCURITÉ. POUR MAINTENIR LE DEGRÉ DE SÉCURITÉ DE L'APPAREIL, NE REMPLACER QUE DES PIÈCES RECOMMANDÉES PAR LE FABRICANT

RECOMMENDED SPARE PARTS

Because, if the parts listed below are on hand, almost any repair can be accomplished, we suggest that you stock these Recommended Spare Parts Items.

NO.	PART NO.	DESCRIPTION
1	N BH-T2068A430C	PLATE ROTARY BLK CMR33
2	BL-T2068A380A	ARM PINCH ROLLER L BLK CMR31
3	BL-T2068A390A	ARM PINCH ROLLER R BLK CMR31
4	BM-B354697	MOTOR CAM PART CMR30
5	BM-B354716	MOTOR CAPSTAN PART CMR30
6	BM-B354714	MOTOR REEL PART CMR30
7	N BT-355306	△ TRANS POWER T2076 (U)
8	N BT-355309	△ TRANS POWER T2076 (A,C)
9	N BT-355311	△ TRANS POWER T2076 (B,S)
10	N BT-355310	△ TRANS POWER T2076 (E,V)
11	N BT-355308	△ TRANS POWER T2076 (J)
12	BZ-T2045A040A	GUIDE DETECTION BLK HX-R5
13	ED-345555	△ D SILICON DBB10C 200/1.0A
14	ED-349662	△ D SILICON DS135E-FA6 F10 100/1.0A
15	ED-309341	D GERMA H 1K34A
16	ED-344244	D LED SLF601C AMBER
17	ED-301911	D SILICON H DS448
18	ED-344280	D SILICON H GMA-01-FY2 F05
19	ED-306109	D SILICON W03B 100/1.0A
20	ED-328486	D ZENER H HZ15 3
21	ED-329056	D ZENER H HZ22 2
22	ED-346455	D ZENER H HZ7FA F10 A1
23	N ED-346458	D ZENER H HZ7FA F10 B1
24	ED-337776	D ZENER H HZ3 C1
25	ED-329058	D ZENER H HZ5 C1
26	ED-331197	D ZENER H HZ6 C1
27	ED-319167	D ZENER H HZ6 C3
28	N ED-355379	D ZENER H HZ6FA F10 C1,2
29	ED-346604	D ZENER H HZ7 B2
30	ED-346607	D ZENER H HZ9 B1
31	N ED-355471	D ZENER V HZ16LS7 F05 3
32	ED-348023	D ZENER V HZ5B-1S7
33	N ED-348024	D ZENER V HZ5B-2S7
34	ED-345027	D ZENER V HZ5C-3S7
35	N ED-348032	D ZENER V HZ7A-3S7
36	EF-358974	△ FUSE BET T 250V 0.63A [B]
37	EF-359342	△ FUSE BET T 400MA 250V [B]
38	EF-318608	△ FUSE GGS A 250V 1.00A [U,J,C,A]
39	EF-668474	△ FUSE SEMKO T 400MA 250V [E,V,S]
40	EF-601942	△ FUSE SEMKO T 639MA 250V [E,V,S]
41	EH-328491	FILTER DB D07-003K 100KHZ
42	EH-328490	FILTER DB Z07-001K 19KHZ
43	EI-354822	IC AN6291
44	EI-349196	IC HA12058
45	EI-356327	IC HA12067
46	EI-337013	IC LB1290
47	EI-355602	IC LB1649
48	EI-337009	IC LC4049B
49	EI-338171	IC LC4069UB
50	EI-337008	IC LC7800
51	N EI-355350	IC M50740A-430SP
52	EI-357498	IC M51143AL
53	N EI-355134	IC M5201L
54	EI-353227	IC M5216L
55	EI-337228	IC M5218L
56	N EI-355115	IC M5240P
57	EI-304657	IC TC4011BP
58	EI-305456	IC TC4049BP
59	EI-349372	OSC CE CSA4.00MG 4MHZ
60	N EM-355326	IND FL BG-290Z
61	EO-337055	COIL VARI 1 FE002S 10MH
62	EQ-337067	RELAY LEAD LAB2NS 2NO 18V
63	ER-331188	△ R FUSE ERD2FC S10 1/4W 8R2J

NO.	PART NO.	DESCRIPTION
64	ER-328278	△ R FUSE ERD2FC 1/4W 10R0G
65	ES-358581	△ SW PUSH J-U3065 01-1
66	N ES-359606	△ SW SELECTOR ST-41S0454 01-4 [U]
67	ES-354767	SW LEAF BSW-243
68	ES-354849	SW LEAF BSW-47BRC-1
69	ES-354850	SW LEAF MSW-1273NBK
70	N ES-355227	SW PUSH SPUY54 5THROW
71	N ES-355332	SW SLIDE SSY02 2-02-02N
72	ES-355604	SW TACT B3F-1020
73	ET-345626	△ TR 2SA1248 S,T
74	ET-316523	△ TR 2SC1844 F
75	ET-345625	△ TR 2SC3116 S,T
76	ET-345091	PHOTO SENSOR SPI-201-40 B,C
77	ET-308472	TR 2SA1115 E,F,G
78	ET-348950	TR 2SA1345
79	ET-349605	TR 2SA1346
80	ET-349626	TR 2SA1347
81	ET-349725	TR 2SA1391 S,T
82	ET-308141	TR 2SC2603 G
83	ET-349883	TR 2SC3243 D,E
84	ET-349080	TR 2SC3382 S,T
85	ET-349081	TR 2SC3383 S,T
86	ET-350795	TR 2SC3399
87	ET-349592	TR 2SC3400
88	ET-338324	TR 2SD1012-V H
89	ET-310148	TR 2SD612K E,F
90	EV-356579	R S-FIX H H0615C 3P 102
91	EV-356576	R S-FIX H H0615C 3P 472
92	EV-336785	R S-FIX H TM8KV2-1S 3P 0.50W 104
93	EV-338464	R S-FIX H V8K4-11(1S) 3P 103
94	EV-357837	R S-FIX H V8K4-11(1S) 3P 104
95	N EV-355380	R S-FIX H V8K4-11(1S) 3P 202
96	EV-338463	R S-FIX H V8K4-11(1S) 3P 203
97	EV-338462	R S-FIX H V8K4-11(1S) 3P 503
98	EV-522652	R S-FIX V V8K1-1 3P 105
99	N EV-355389	VR SLIDE VJ2013-2GPVN 10C B103
100	N EV-355232	VR SLIDE VJ8012 G PVN 15B A104
101	N EV-355231	VR SLIDE 35P2SVOJ 1Z104
102	HZ-354673	GEAR ROTARY
103	HZ-354675	LEVER GEAR REVERSE
104	MB-354707	BELT CAPSTAN (A)
105	MI-354706	FLYWHEEL
106	ML-B354723	ARM WIND PART CMR30
107	MZ-354737	CAM WHEEL LOADING
108	MZ-B354735	CAM WHEEL MAIN PART CMR30
109	MZ-354733	CAM WHEEL SUB
110	MZ-354682	GEAR CAM (B)
111	MZ-354683	GEAR CAM (C)
112	MZ-354762	GEAR JOINT
113	MZ-354684	GEAR MIDDLE
114	MZ-B354689	GEAR SLIDE PART CMR30
115	MZ-354715	GEAR WORM WIND

“NOTE” N: New Parts

SYMBOL FOR DESTINATION

- [A] : AAL (U.S.A)
- [B] : UK (England)
- [C] : CSA (Canada)
- [E] : CEE (Europe)
- [J] : JPN (Japan)
- [S] : SAA (Australia)
- [U] : U/T (Universal Area)
- [V] : VDE (West Germany)

MECHA CMR33 BLOCK (1)

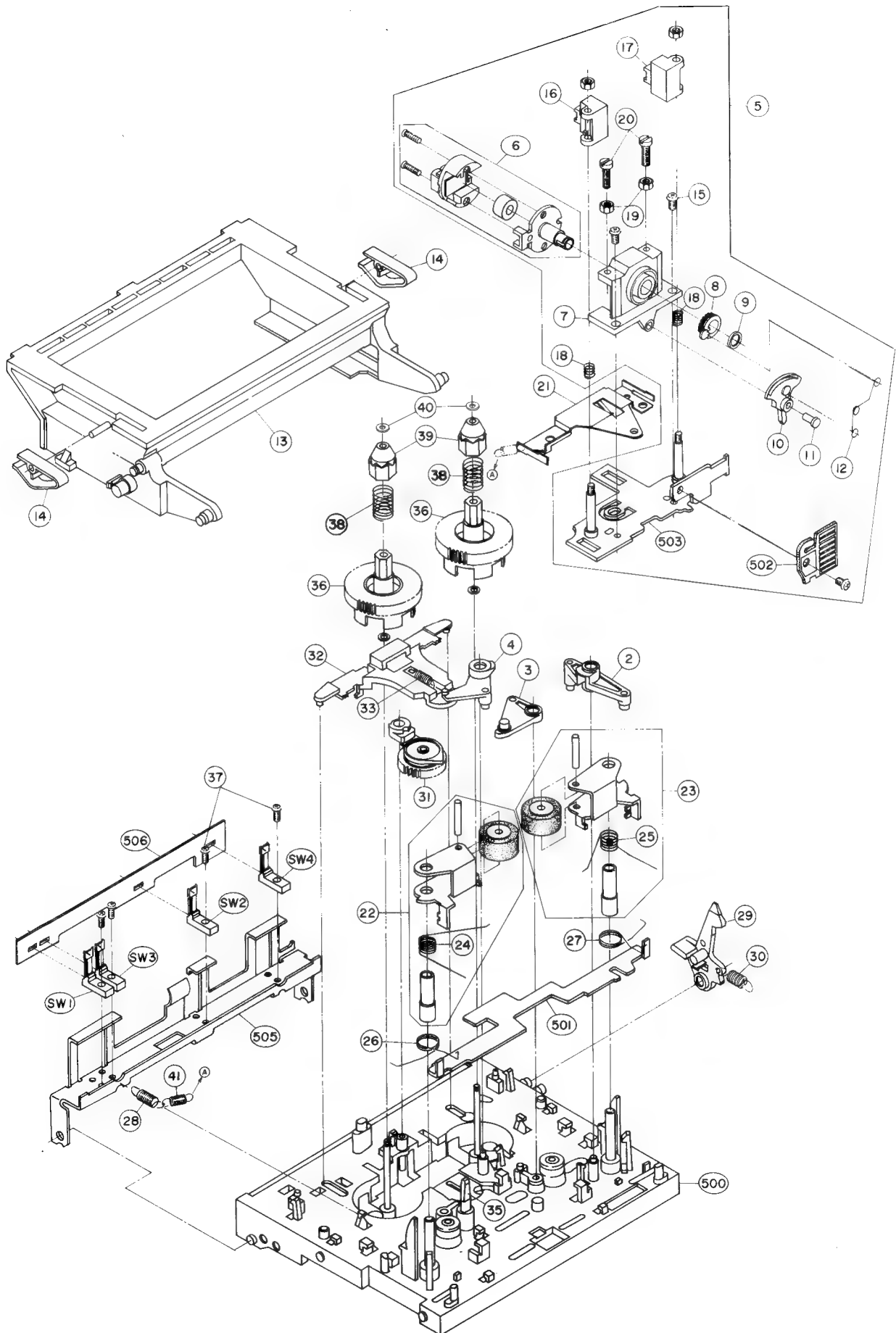

PARTS LIST

1. MECHA CMR33 BLOCK (1)

REF. NO.	PART NO.	DESCRIPTION
1-1	BB-T2068A300D	MECHA CMR33 BLK
1-2	ML-354699	LEVER PINCH ROLLER DRIVE
1-3	ML-354700	LEVER HEAD DRIVE
1-4	ML-354701	LEVER BRAKE DRIVE
1-5	BH-T2068A370D	HEAD BLK CMR 33
1-6	BH-T2068A430C	PLATE ROTARY BLK CMR33
1-7	HZ-354764B	HOLDER HEAD (B)
1-8	HZ-354673	GEAR ROTARY
1-9	ZW-354674	PW38x055x050PSL
1-10	HZ-354675	LEVER GEAR REVERSE
1-11	HZ-354676	PROP GEAR REVERSE
1-12	ZG-354745	SP TORSION ROTARY
1-13	BD-B359140	LID CASE (B) PART
1-14	ZG-336615	SP PLATE CASSETTE HOLDER (B)
1-15	ZS-417161	PAN23x04STL CMT
1-16	BZ-T2045A040A	GUIDE DETECTION BLK HX-R5
1-17	HZ-344093	GUIDE TAPE
1-18	ZG-344012	SP PUSH GUIDE TAPE
1-19	ZW-618884	N20STL CMT 1
1-20	ZS-344001	SCREW AZIMUTH
1-21	ZG-354749	SP PLATE HEAD PUSH
1-22	BL-T2068A380A	ARM PINCH ROLLER L BLK CMR31
1-23	BL-T2068A390A	ARM PINCH ROLLER R BLK CMR31
1-24	ZG-354750	SP TORSION PINCH ROLLER (L)
1-25	ZG-354751	SP TORSION PINCH ROLLER (R)
1-26	ZG-354752	SP TORSION RETURN (L)
1-27	ZG-354753	SP TORTION RETURN (R)
1-28	ZG-359409	SP PULL HOLDER LEAF
1-29	ML-354754	ARM LOCK LOADING
1-30	ZG-357749	SP T6-04.0/0.40-16.0 T6-111
1-31	ML-B354723	ARM WIND PART CMR30
1-32	MZ-354734	SLIDE BRAKE
1-33	ZG-357808	SP T6-03.2/0.29-11.2 T6-059
1-34	ZW-305546	PW21x040x025PSL
1-35	MH-354679	PROP REFRENCE
1-36	MR-359138	PULLEY REEL (B)
1-37	ZS-460440	PAN20x04STL CMT
1-38	ZG-354718	SP PUSH BT (B)
1-39	MT-349681	REEL RETAINER (B)
1-40	ZW-343120	PW17x040x025PSL
1-41	ZG-355133	SP PULL EARTH
1-SW1	ES-354767	SW LEAF BSW-243
1-SW2	ES-354767	SW LEAF BSW-243
1-SW3	ES-354767	SW LEAF BSW-243
1-SW4	ES-354767	SW LEAF BSW-243

NOTE: Parts listed in 1 to SW4 on the exploded view and list are normally stocked for replacement purpose. The remaining parts shown in this manual are not normally stocked, because they are seldom required for routine service.

MECHA CMR33 BLOCK (2)

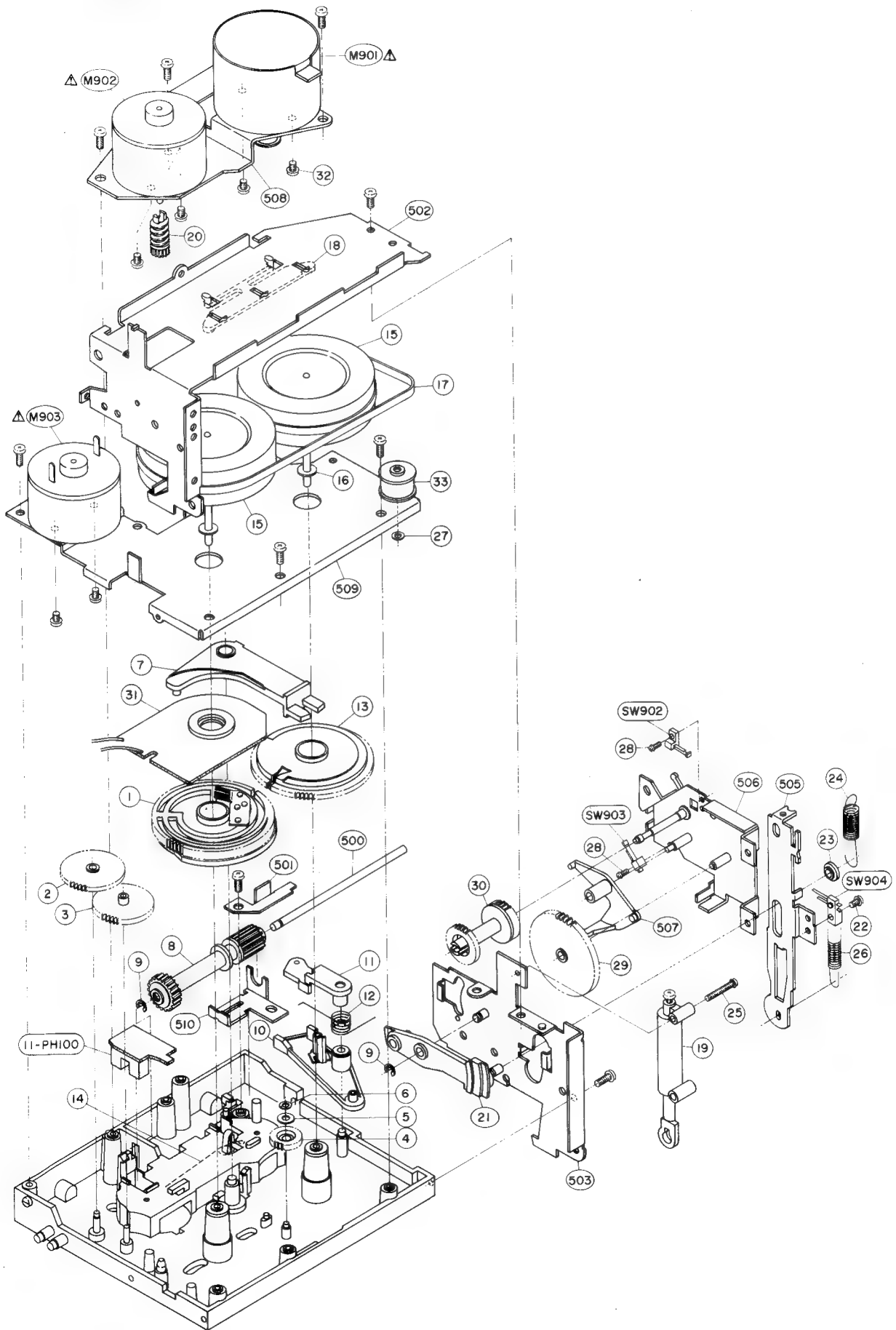

PARTS LIST

2. MECHA CMR33 BLOCK (2)

REF. NO.	PART NO.	DESCRIPTION
MECHA CMR33 BLOCK		
2-1	MZ-B354735	CAM WHEEL MAIN PART CMR30
2-2	MZ-354682	GEAR CAM (B)
2-3	MZ-354683	GEAR CAM (C)
2-4	MZ-354684	GEAR MIDDLE
2-5	ZW-300885	PW23x060x020PBR
2-6	ZW-340648	RING CS 190STL PKR
2-7	ML-354685	ARM HEAD REVERSE
2-8	MZ-B354689	GEAR SLIDE PART CMR30
2-9	ZW-270088	RING E190SUP CMT
2-10	ML-354691	ARM GEAR SLIDE (A)
2-11	ML-354692	ARM GEAR SLIDE (B)
2-12	ZG-354747	GEAR TORSION ARM SLIDE
2-13	MZ-354733	CAM WHEEL SUB
2-14	ZG-355016	SP TORSION EARTH
2-15	MI-354706	FLYWHEEL
2-16	ZW-536466	PW21x070x050NYL
2-17	MB-354707	BELT CAPSTAN (A)
2-18	MZ-354709	HOLDER THRUST
2-19	MZ-344099	DAMPER ASSY
2-20	MZ-354715	GEAR WORM WIND
2-21	ML-B354710	ARM LOADING PART CMR30
2-22	ZS-328606	PAN20x30STL CMT
2-23	SZ-354719	COLLAR LOADING
2-24	ZG-354757	SP PULL LOADING
2-25	ZS-343113	ST PAN20x12STL CMT
2-26	ZG-354759	SP PULL LID LOCK
2-27	ZW-343120	PW17x040x025PSL
2-28	ZS-477876	PAN20x03STL CMT
2-29	MZ-354737	CAM WHEEL LOADING
2-30	MZ-354762	GEAR JOINT
2-31	EA-354860	PC ROTARY ENCODER
2-32	ZS-592378	PAN26x035STL CMT
2-33	MR-B354695	PULLEY MIDDLE PART CMR30
2-M901	BM-B354716	Δ MOTOR CAPSTAN PART CMR30
2-M902	BM-B354714	Δ MOTOR REEL PART CMR30
2-M903	BM-B354697	Δ MOTOR CAM PART CMR30
2-SW902	ES-354850	SW LEAF MSW-1273NBK
2-SW903	ES-354850	SWLEAF MSW-1273NBK
2-SW904	ES-354849	SW LEAF BSW-47BRC-1
CONTROL (B) B PC BOARD		
11-PH100	ET-345091	PHOTO SENSOR SPI-201-40 B,C

NOTE: Parts listed in 1 to SW904 on the exploded view and list are normally stocked for replacement purpose. The remaining parts shown in this manual are not normally stocked, because they are seldom required for routine service.

3. PC BOARD BLOCK

REF. NO.	PART NO.	DESCRIPTION
3-1A	BA-T2074A020B	PC PRE & POWER BLK GX-R60(U) [EXCEPT J]
3-1B	BA-T2074A020D	PC PRE & POWER BLK GX-R60(J) [J]
3-2	BA-T2074A030B	PC SYSCON/METER BLK GX-R60

NOTES: (1) PC PRE & POWER BLK consists of following PC BOARDS.

- PRE AMP & POWER SUPPLY PC BOARD
- HEAD PHONE PC BOARD
- POWER SW PC BOARD

(2) PC SYSCON/METER BLK consists of following PC BOARDS.

- SYSTEM CONTROL (A) PC BOARD
- SYSTEM CONTROL (D) PC BOARD
- METER PC BOARD

4. PRE AMP & POWER SUPPLY PC BOARD

REF. NO.	PART NO.	DESCRIPTION
PRE AMP & POWER SUPPLY PC BOARD		
4-IC4	EI-337228	IC M5218L
4-IC7	EI-357498	IC M51143AL
4-IC8	EI-305456	IC TC4049BP
4-IC9	EI-354822	IC AN6291
4-IC10	EI-355134	IC M5201L
4-IC11	EI-353227	IC M5216L
4-IC12	EI-349196	IC HA12058
4-IC13	EI-355115	IC M5240P
4-TR15	ET-349080	TR 2SC3382 S,T
4-TR18	ET-349592	TR 2SC3400
4-TR19	ET-310148	TR 2SD612K E,F
4-TR20,21	ET-349081	TR 2SC3383 S,T
4-TR22,23	ET-349592	TR 2SC3400
4-TR26,27	ET-349883	TR 2SC3243 D,E
4-TR29	ET-349725	TR 2SA1391 S,T
4-TR30	ET-349080	TR 2SC3382 S,T
4-TR31	ET-345626	△ TR 2SA1248 S,T
4-TR32	ET-345625	△ TR 2SC3116 S,T
4-TR33	ET-349080	TR 2SC3382 S,T
4-TR34	ET-349725	TR 2SA1391 S,T
4-TR35	ET-349080	TR 2SC3382 S,T
4-TR36,37	ET-349725	TR 2SA1391 S,T
4-TR38	ET-349080	TR 2SC3382 S,T
4-TR39	ET-349080	△ TR 2SC3382 S,T
4-TR40	ET-316523	△ TR 2SC1844 F
4-TR41	ET-349080	TR 2SC3382 S,T
4-TR42	ET-345625	△ TR 2SC3116 S,T
4-TR43	ET-349080	TR 2SC3382 S,T
4-TR44	ET-345625	△ TR 2SC3116 S,T
4-TR45	ET-349080	TR 2SC3382 S,T
4-TR46	ET-308141	△ TR 2SC2603 G
4-TR47	ET-308472	TR 2SA1115 E,F,G
4-TR48	ET-310148	△ TR 2SD612K E,F
4-TR49,50	ET-349081	TR 2SC3383 S,T
4-TR51	ET-349605	TR 2SA1346
4-TR52	ET-349592	TR 2SC3400
4-TR53to55	ET-349080	TR 2SC3382 S,T
4-TR60	ET-349080	TR 2SC3382 S,T
4-TR61to63	ET-349081	TR 2SC3383 S,T
4-TR64	ET-349080	TR 2SC3382 S,T
4-TR65,66	ET-349605	TR 2SA1346
4-TR67,68	ET-349081	TR 2SC3383 S,T

REF. NO.	PART NO.	DESCRIPTION
4-TR69	ET-349605	TR 2SA1346
4-TR70	ET-349592	TR 2SC3400
4-TR71	ET-338324	TR 2SD1012-V H
4-TR72to74	ET-349080	TR 2SC3382 S,T
4-TR75	ET-349725	TR 2SA1391 S,T
4-TR76	ET-349080	TR 2SC3382 S,T
4-TR77,78	ET-349081	TR 2SC3383 S,T
4-D6	ED-346604	D ZENER H HZ7 B2
4-D10	ED-301911	D SILICON H DS448
4-D15to18	ED-349662	△ D SILICON DS135E-FA6 F10 100/1.0A
4-D19	ED-345555	△ D SILICON DBB10C 200/1.0A
4-D20,21	ED-348024	D ZENER V HZ5B-2S7
4-D22	ED-319167	D ZENER H HZ6 C3
4-D23	ED-345555	△ D SILICON DBB10C 200/1.0A
4-D24	ED-301911	D SILICON H DS448
4-D25	ED-329056	D ZENER H HZ22 2
4-D26	ED-355471	D ZENER V HZ16LS7 F05 3
4-D27	ED-319167	D ZENER H HZ6 C3
4-D28	ED-344280	D SILICON H GMA-01-FY2 F05
4-D29	ED-348032	D ZENER V HZ7A-3S7
4-D30	ED-345027	D ZENER V HZ5C-3S7
4-D31to36	ED-301911	D SILICON H DS448
4-D37	ED-309341	D GERMA H 1K34A
4-D38,39	ED-355379	D ZENER H HZ6FA F10 C1,2
4-D40	ED-348023	D ZENER V HZ5B-1S7
4-D41	ED-344280	D SILICON H GMA-01-FY2 F05
4-D42	ED-301911	D SILICON H DS448
4-D43	ED-329058	D ZENER H HZ5 C1
4-SW1	ES-355227	SW PUSH SPUY54 5THROW
4-VR1	EV-355232	VR SLIDE VJ8012 G PVN 15B A104
4-VR2	EV-356579	R S-FIX H H0615C 3P 102
4-VR3	EV-356576	R S-FIX H H0615C 3P 472
4-VR4	EV-336785	R S-FIX H TM8KV2-1S 3P 0.50W 104
4-VR5	EV-338463	R S-FIX H V8K4-11(1S) 3P 203
4-VR6	EV-357837	R S-FIX H V8K4-11(1S) 3P 104
4-VR7	EV-355380	R S-FIX H V8K4-11(1S) 3P 202
4-VR8	EV-338464	R S-FIX H V8K4-11(1S) 3P 103
4-VR9	EV-338462	R S-FIX H V8K4-11(1S) 3P 503
4-FL1	EH-328491	FILTER DB D07-003K 100KHZ
4-FL2	EH-328490	FILTER DB Z07-001K 19KHZ
4-FL3	EO-315758	COIL TUN 1 100Z-431 100.00KHZ
4-FL4	EO-337044	COIL TUN 1 102AZ-005
4-L1	EO-355696	COIL FIX 1 LAL04SK 330K
4-L2	EO-337055	COIL VARI 1 FE002S 10MH
4-RL1	EQ-337067	RELAY LEAD LAB2NS 2NO 18V
4-T1	EO-355136	COIL OSC2 94-5014-01 100KHZ
4-FR1,2	ER-328278	△ R FUSE ERD2FC 1/4W 10R0G
4-FR3,4	ER-331188	△ R FUSE ERD2FC S10 1/4W 8R2J
4-R32	ER-338498	R MF H F10 1/4W 102J
4-R38	ER-355370	R MF H F10 1/4W 4221G
4-R39	ER-356257	R MF H F10 1/4W 5601G
4-R83,84	ER-359160	R MF V CUT 1/4W 3901G
4-R85,86	ER-361094	R MF V CUT 1/4W 5601G
4-R113	ER-356698	R MF H F10 1/4W 2202G
4-R114	ER-355400	R MF H F10 1/4W 1101G
4-R122	ER-338225	R MF H F10 1/4W 331J
4-R125	ER-356250	R MF H F10 1/4W 4700G
4-R126	ER-356252	R MF H F10 1/4W 4701G
4-R127	ER-314586	R MF H 1/4W 5101F
4-R130	ER-314626	R MF H 1/4W 1801F
4-R131	ER-311762	R MF H 1/4W 9101F
4-R132	ER-356251	R MF H F10 1/4W 1002G
4-R135,136	ER-338225	R MF H F10 1/4W 331J
4-R137	ER-360311	R MF H F10 1/4W 3303G
4-R138	ER-307730	R MF H F10 1/4W 7502F
4-R139	ER-318335	R MF H F10 1/4W 8202F
4-R140	ER-314606	R MF H 1/4W 3601F
4-R141	ER-356247	R MF H F10 1/4W 2701G
4-R171	ER-356698	R MF H F10 1/4W 2202G
4-R172	ER-355400	R MF H F10 1/4W 1101G

REF. NO.	PART NO.	DESCRIPTION
4-R202	ER-338498	R MF H F10 1/4W 102J
4-R213	ER-355703	R MF H F10 1/4W 1202G
4-R214	ER-361096	R MF H F10 1/4W 3002G
4-R215	ER-321084	R MF H F10 1/4W 3003F
4-R216	ER-338224	R MF H F10 1/4W 392J
4-R248	ER-356258	R MF H F10 1/4W 4302G
4-R251	ER-356251	R MF H F10 1/4W 1002G
4-R254	ER-311771	R MF H 1/4W 1500F
4-R255	ER-338498	R MF H F10 1/4W 102J
4-R257	ER-355705	R MF H F10 1/4W 1500G
4-R258	ER-338498	R MF H F10 1/4W 102J
4-C5	EC-300193	C EC V F05 NP SM 100M 16DC
4-C38	EC-347228	C MC V F05 FM 470J 500DC
4-C39	EC-316149	C STY V F05 CQ09S 182J 500DC
4-C41,42	EC-316187	C EC V CUT SM 102M 16DC
4-C60	EC-315967	C EC V CUT SM 332M 16.0DC
4-C68	EC-351993	C COMP V AWS 562J 50DC
4-C69	EC-351994	C COMP V AWS 152J 50DC
4-C76	EC-357784	C COMP V AWS 433J 50DC
4-C77	EC-347471	C PP V F05 PP 471J 50DC
4-C80	EC-332052	C EC V F05 NP SM 4R7M 35DC
4-C81	EC-356994	C COMP V AWS 202J 50DC
4-C89	EC-314992	C STY V S05 CQFS 681J 50DC
4-C93,94	EC-200948	C EC V F05 NP SM 1R0M 50DC
4-C109	EC-310440	C STY V S05 CQFS 571J 50DC
4-C119	EC-307494	C STY V F05 CQ09S 331J 50DC
4-C132	EC-334011	C EC V F05 NP SM 101M 6.3DC
4-C136	EC-314996	C STY V S05 CQFS 391J 50DC
4-C148	EC-300193	C EC V F05 NP SM 100M 16DC
4-C162	EC-360693	C MC V F05 FE92 100J 500DC
4-C163	EC-334011	C EC V F05 NP SM 101M 6.3DC
4-C164	EC-347367	C MC V F05 FE92 150J 500DC
4-C166	EC-352008	C COMP V AWS 912J 50DC
4-C167	EC-346879	C PP V F05 PP 221J 50DC
4-C172	EC-351980	C EC V F05 NP SM R33M 50.0DC
4-C173	EC-350680	C COMP V AWS 123J 50DC
4-C175	EC-200948	C EC V F05 NP SM 1R0M 50DC
4-J1A	EJ-347664	PIN J YKC21-5053 P 4P [EXCEPT J]
4-J1B	EJ-361072	PIN J YKC21 P 4P [J]
4-J2	EJ-346076	DIN J TCS4690-01-1111 P 8P
ASSEMBLY BLOCK		
4-F1A	EF-318608	△ FUSE GGS A 250V 1.00A [U,J,C,A]
4-F1B	EF-358974	△ FUSE BET T 630MA 250V[B]
4-F1C	EF-601942	△ FUSE SEMKO T 630MA 250V [E,V,S]
4-F2A	EF-318608	△ FUSE GGS A 250V 1.00A [U,J,C,A]
4-F2B	EF-358974	△ FUSE BET T 250V 0.63A [B]
4-F2C	EF-601942	△ FUSE SEMKO T 630MA 250V [E,V,S]
4-F3A	EF-318608	△ FUSE GGS A 250V 1.00A [U,J,C,A]
4-F3B	EF-359342	△ FUSE BET T 400MA 250V[B]
4-F3C	EF-668474	△ FUSE SEMKO T 400MA 250V [E,V,S]

5. SYSTEM CONTROL (A) PC BOARD

REF. NO.	PART NO.	DESCRIPTION
5-IC1	EI-355350	IC M50740A-430SP
5-IC2	EI-355602	IC LB1649
5-IC3	EI-337008	IC LC7800
5-IC4	EI-337009	IC LC4049B
5-IC5	EI-337013	IC LB1290
5-IC6	EI-338171	IC LC4069UB
5-IC7	EI-337013	IC LB1290
5-TR1,2	ET-350795	TR 2SC3399
5-TR3,4	ET-308141	TR 2SC2603 G
5-TR5,6	ET-308472	TR 2SA1115 E,F,G
5-TR7,8	ET-350795	TR 2SC3399
5-TR10	ET-350795	TR 2SC3399
5-TR27	ET-349626	TR 2SA1347
5-TR28	ET-310148	TR 2SD612K E,F
5-TR29	ET-308141	TR 2SC2603 G
5-TR30	ET-350795	TR 2SC3399
5-D1	ED-337776	D ZENER H HZ3 C1
5-D2	ED-346458	D ZENER H HZ7FA F10 B1
5-D3	ED-346455	D ZENER H HX7FA F10 A1
5-D4	ED-346607	D ZENER H HZ9 B1
5-D5	ED-306109	D SILICON W03B 100/1.0A
5-D6to9	ED-301911	D SILICON H DS448
5-D11,13	ED-301911	D SILICON H DS448
5-D15,16	ED-301911	D SILICON H DS448
5-D17to19	ED-328486	D ZENER H HZ15 3
5-D43	ED-301911	D SILICON H DS448
5-D48to52	ED-301911	D SILICON H DS448
5-D53	ED-331197	D ZENER H HZ6 C1
5-D54	ED-301911	D SILICON H DS448
5-VR1	EV-522652	R S-FIX V V8K1-1 3P 105
5-X1	EI-349372	OSC CE CSA.4.00MG 4MHZ
5-IB1	EH-355320	COMP R M3874
5-IB2	EH-355321	COMP R RKC1/8B13 103J
5-IB4	EH-356520	COMP C EXF-P4 103ZF
5-IB5	EH-355323	COMP C EXF-P6 103ZF
5-C3	EC-316187	C EC V CUT SM 102M 16DC

5A. LOADING PC BOARD

REF. NO.	PART NO.	DESCRIPTION
5A-TR1	ET-349626	TR 2SA1347
5A-TR2	ET-350795	TR 2SC3399
5A-TR3	ET-350795	TR 2SC3399
5A-D2	ED-301911	D SILICON H DS448

6. SYSTEM CONTROL (D) PC BOARD

REF. NO.	PART NO.	DESCRIPTION
6-IC301	EI-304657	IC TC4011BP
6-TR301	ET-350795	TR 2SC3399
6-TR302	ET-348950	TR 2SA1345
6-TR303	ET-350795	TR 2SC3399
6-D301to306	ED-301911	D SILICON H DS448

7. METER PC BOARD

REF. NO.	PART NO.	DESCRIPTION
7-IC101	EI-356327	IC HA12067
7-D101	ED-301911	D SILICON H DS448
7-SW101	ES-355332	SW SLIDE SSY02 2-02-02N
7-SW102to110	ES-355604	SW TACT B3F-1020
7-SW111	ES-355332	SW SLIDE SSY02 2-02-02N
7-VR101	EV-355389	VR SLIDE VJ2013-2GPVN 10C B103
7-VR102	EV-355231	VR SLIDE 35P2SVOJ 1Z104
7-IN1	EM-355326	IND FL BG-290Z

8. CONTROL (B) A PC BOARD

REF. NO.	PART NO.	DESCRIPTION
8-R100	ER-306127	R CB H S15 FS RDS 1/2W 681J
8-R101	ER-333668	R CB H S15 FS RDS 1/2W 431J

9. FILTER PC BOARD

REF. NO.	PART NO.	DESCRIPTION
9-L1,2	EO-669273	COIL FIX 2 FL5R200 180

10. HEAD PHONE PC BOARD

REF. NO.	PART NO.	DESCRIPTION
19-J3	EJ-348846	PHONE J 3P HLJ0540 6.3

11. CONTROL (B) B PC BOARD

REF. NO.	PART NO.	DESCRIPTION
11-PH100	ET-345091	PHOTO SENSOR SPI-201-40 B,C

12. POWER SW PC BOARD

REF. NO.	PART NO.	DESCRIPTION
12-SW2	ES-358581	△ SW PUSH J-U3065 01-1
12-C204	EC-355371	△ C CE V F 472Z 400AC

13. ASSEMBLY BLOCK

REF. NO.	PART NO.	DESCRIPTION
ASSEMBLY BLOCK		
13-1	SA-349332	FOOT
13-2	ZS-344754	ST PAN30x06STL CMT C080 [FOOT FIX]
13-3	ZS-304022	ST PAN40x06STL CMT [POWER TRANS FIX]
13-4A	EW-355312	△ AC CORD 2 CORES VM-0129A, VFF-CBU/T [U]
13-4B	EW-355521	△ AC CORD 2 CORES KP-210 J [J]
13-4C	EW-355318	△ AC CORD 2 CORES KP10, SPT2-CB UC [C,A]
13-4D	EW-355315	△ AC CORD 2 CORES VM0364, 2x0.75-CB EV [E,V]
13-4E	EW-355316	△ AC CORD 2 CORES LC2x0.75-CB [B]
13-4F	EW-355317	△ AC CORD 2 CORES VM0436, 2x0.75-CB [S]
13-5	EZ-361283	STRAIN RELIEF SR-5N-5 [J]
13-6	ZW-698308	RV NYL30x055 BL
13-7A	SP-355354A	PANEL REAR BOARD GX-R60 [U]
13-7B	SP-355354B	PANEL REAR BOARD GX-R60 [J]
13-7C	SP-355354C	PANEL REAR BOARD GX-R60[A,C]
13-7D	SP-355354D	PANEL REAR BOARD GX-R60[E,V]
13-7E	SP-355354E	PANEL REAR BOARD GX-R60[B,S]
13-8	ZS-352120	T2BR30x08STL BCM C080
13-9	ZS-455207	T2BR30x05STL CMT [COVER UPPER FIX]
13-10x	AX-603167	CORD RR-163 PIN-PIN/2P
13-T901A	BT-355306	△ TRANS POWER T2076(U)
13-T901B	BT-355308	△ TRANS POWER T2076(J)
13-T901C	BT-355309	△ TRANS POWER T2076(A,C)
13-T901D	BT-355310	△ TRANS POWER T2076(E,V)
13-T901E	BT-355311	△ TRANS POWER T2076(B,S)
13-VS901	ES-359606	△ SW SELECTOR 8T-41S0454 01-4 [U]

PRE AMP & POWER SUPPLY PC BOARD

4-J1A	EJ-347664	PIN J YKC21-5053 P 4P [EXCEPT J]
4-J1B	EJ-361072	PIN J YKC21 P 4P [J]
4-J2	EJ-346076	DIN J TCS4690-01-1111 P 8P

ASSEMBLY BLOCK

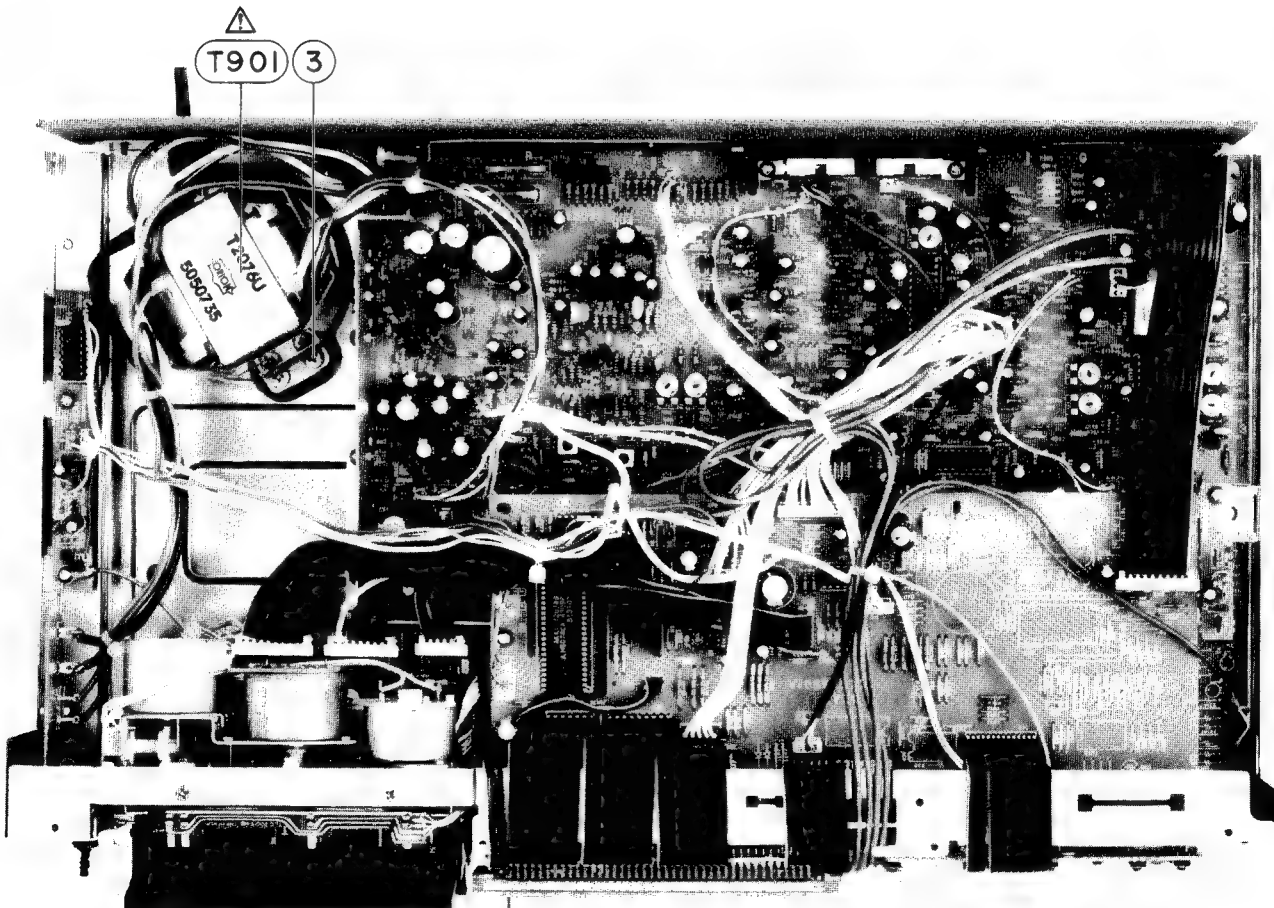
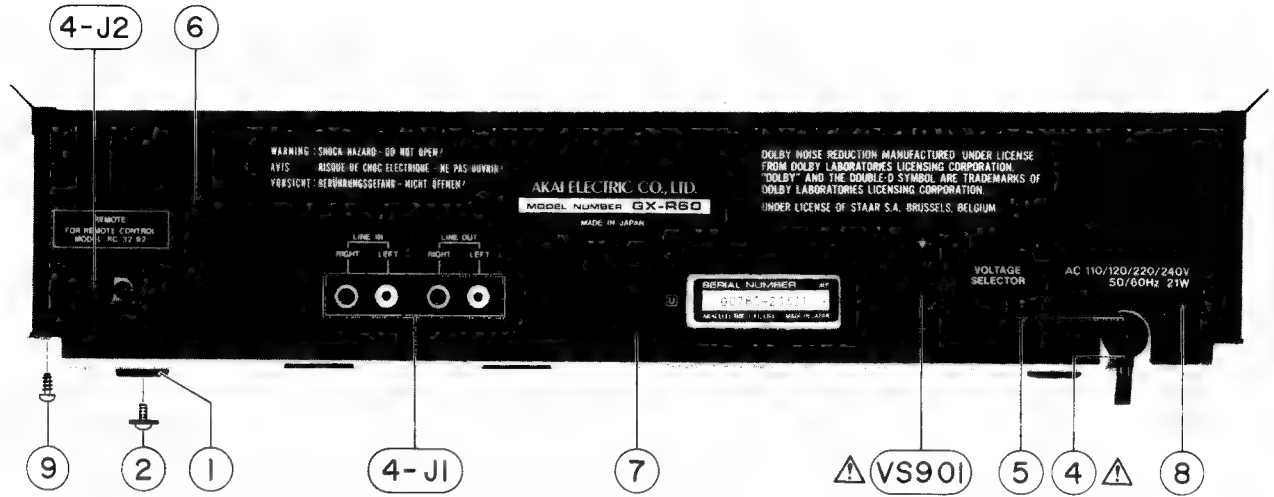

FINAL ASSEMBLY BLOCK

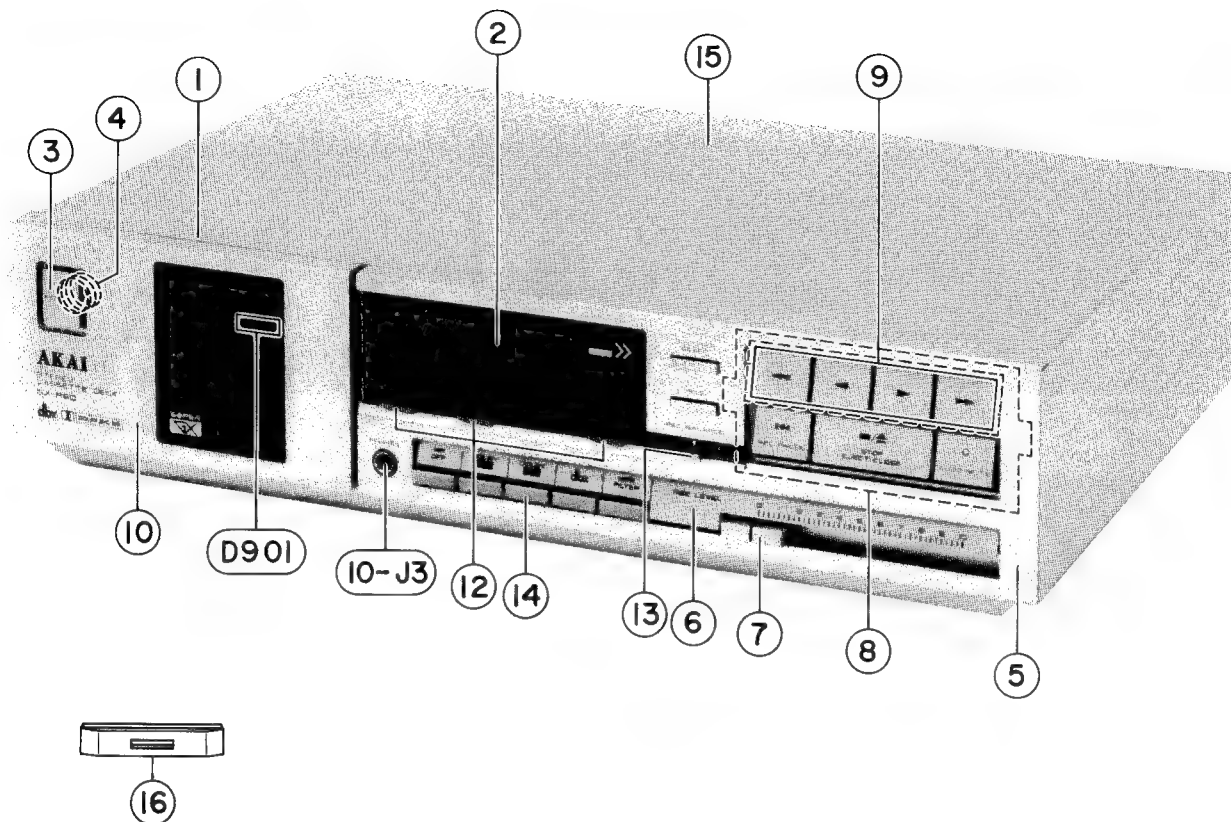

14. FINAL ASSEMBLY BLOCK

REF. NO.	PART NO.	DESCRIPTION
PANEL FRONT BLOCK		
14-1	BD-T2076A020A	PANEL FRONT BLK GX-R60
14-1B	BD-T2076A020B	PANEL FRONT BLK GX-R60-B
14-2	SZ-355243	WINDOW METER
14-3	SK-343017G	KNOB POWER
14-3B	SK-343017F	KNOB POWER-B
14-4	ZG-355238	SP PUSH POWER
14-5	SP-355259	PANEL SUB
14-5B	SP-355259B	PANEL SUB-B
14-6	SP-355255A	PANEL FUNCTION GX-R60
14-6B	SP-355255B	PANEL FUNCTION GX-R60-B
14-7	SK-355250A	KNOB REC LEVEL
14-7B	SK-355250B	KNOB REC LEVEL-B
14-8	SK-355254C	KNOB OPERATION (2)
14-8B	SK-355254D	KNOB OPERATION (2)-B
14-9	SK-355246C	KNOB DIRECTION (2)
14-9B	SK-355246D	KNOB DIRECTION (2)-B
14-D901	ED-344244	D LED SLF601C AMBER [REFLECTOR]

LID PANEL BLOCK		
14-10	BD-T2074A050B	LID PANEL BLK GX-R60
14-10B	BD-T2074A050D	LID PANEL BLK GX-R60-B

REF. NO.	PART NO.	DESCRIPTION
FINAL ASSEMBLY BLOCK		
14-11x	ZS-320906	ST BR30x06STL CMT [PANEL FRONT FIX]
14-12	SK-355248A	KNOB SLIDE
14-12B	SK-355248B	KNOB SLIDE-B
14-13	SK-355249A	KNOB BALANCE
14-13B	SK-355249B	KNOB BALANCE-B
14-14	SK-355247A	KNOB PUSH
14-14B	SK-355247B	KNOB PUSH-B
14-15	SP-344591A	COVER UPPER
14-15B	SP-344591D	COVER UPPER-B(2)
14-16	SE-359322A	PLATE MASK
14-16B	SE-359322B	PLATE MASK-B
HEAD PHONE PC BOARD		
10-J3	EJ-348846	PHONE J 3P HLJ0540 6.3

NOTE: PANEL FRONT BLK consists of 14-2 to 14-D901.

SYMBOL FOR COLOR VARIATION

NON : STANDARD COLOR
B or BL : BLACK

INDEX

PART NO.	REF. NO.	PART NO.	REF. NO.	PART NO.	REF. NO.	PART NO.	REF. NO.
AX-603167	13-10x	ED-301911	6-D302	EO-355696	4-L1	ET-345091	11-PH100
BA-T2074A020B	3-1A	ED-301911	6-D303	EO-669273	9-L1	ET-345625	4-TR44
BA-T2074A020D	3-1B	ED-301911	6-D304	EO-669273	9-L2	ET-345625	4-TR32
BA-T2074A030B	3-2	ED-301911	6-D305	EQ-337067	4-RL1	ET-345625	4-TR42
BB-T2068A300D	1-1	ED-301911	6-D306	ER-306127	8-R100	ET-345626	4-TR31
BD-B359140	1-13	ED-301911	7-D101	ER-307730	4-R138	ET-348950	6-TR302
BD-T2074A050B	14-10	ED-306109	5-D5	ER-311762	4-R131	ET-349080	4-TR45
BD-T2074A050D	14-10B	ED-309341	4-D37	ER-311771	4-R254	ET-349080	4-TR54
BD-T2076A020A	14-1	ED-319167	4-D22	ER-314586	4-R127	ET-349080	4-TR53
BD-T2076A020B	14-1B	ED-319167	4-D27	ER-314606	4-R140	ET-349080	4-TR55
BH-T2068A370D	1-5	ED-328486	5-D18	ER-314626	4-R130	ET-349080	4-TR60
BH-T2068A430C	1-6	ED-328486	5-D17	ER-318335	4-R139	ET-349080	4-TR64
BL-T2068A380A	1-22	ED-328486	5-D19	ER-321084	4-R215	ET-349080	4-TR72
BL-T2068A390A	1-23	ED-329056	4-D25	ER-328278	4-FR1	ET-349080	4-TR73
BM-B354697	2-M903	ED-329058	4-D43	ER-328278	4-FR2	ET-349080	4-TR74
BM-B354714	2-M902	ED-331197	5-D53	ER-331188	4-FR3	ET-349080	4-TR76
BM-B354716	2-M901	ED-337776	5-D1	ER-331188	4-FR4	ET-349080	4-TR15
BT-355306	13-T901A	ED-344244	14-D901	ER-333668	8-R101	ET-349080	4-TR30
BT-355308	13-T901B	ED-344280	4-D28	ER-338224	4-R216	ET-349080	4-TR33
BT-355309	13-T901C	ED-344280	4-D41	ER-338225	4-R122	ET-349080	4-TR35
BT-355310	13-T901D	ED-345027	4-D30	ER-338225	4-R135	ET-349080	4-TR39
BT-355311	13-T901E	ED-345555	4-D19	ER-338225	4-R136	ET-349080	4-TR41
BZ-T2045A040A	1-16	ED-345555	4-D23	ER-338498	4-R32	ET-349080	4-TR38
EA-354860	2-31	ED-346455	5-D3	ER-338498	4-R202	ET-349080	4-TR43
EC-200948	4-C93	ED-346458	5-D2	ER-338498	4-R255	ET-349081	4-TR49
EC-200948	4-C94	ED-346604	4-D6	ER-338498	4-R258	ET-349081	4-TR50
EC-200948	4-C175	ED-346607	5-D4	ER-355370	4-R38	ET-349081	4-TR61
EC-300193	4-C148	ED-348023	4-D40	ER-355400	4-R114	ET-349081	4-TR62
EC-300193	4-C5	ED-348024	4-D20	ER-355400	4-R172	ET-349081	4-TR63
EC-307494	4-C119	ED-348024	4-D21	ER-355703	4-R213	ET-349081	4-TR67
EC-310440	4-C109	ED-348032	4-D29	ER-355705	4-R257	ET-349081	4-TR68
EC-314992	4-C89	ED-349662	4-D15	ER-356247	4-R141	ET-349081	4-TR77
EC-314996	4-C136	ED-349662	4-D16	ER-356250	4-R125	ET-349081	4-TR78
EC-315967	4-C60	ED-349662	4-D17	ER-356251	4-R132	ET-349081	4-TR20
EC-316149	4-C39	ED-349662	4-D18	ER-356251	4-R251	ET-349081	4-TR21
EC-316187	4-C41	ED-355379	4-D38	ER-356252	4-R126	ET-349592	4-TR52
EC-316187	4-C42	ED-355379	4-D39	ER-356257	4-R39	ET-349592	4-TR70
EC-316187	5-C3	ED-355471	4-D26	ER-356258	4-R248	ET-349592	4-TR18
EC-332052	4-C80	EF-318608	4-F1A	ER-356698	4-R113	ET-349592	4-TR22
EC-334011	4-C132	EF-318608	4-F2A	ER-356698	4-R171	ET-349592	4-TR23
EC-334011	4-C163	EF-318608	4-F3A	ER-359160	4-R83	ET-349605	4-TR51
EC-346879	4-C167	EF-358974	4-F1B	ER-359160	4-R84	ET-349605	4-TR65
EC-347228	4-C38	EF-358974	4-F2B	ER-360311	4-R137	ET-349605	4-TR66
EC-347367	4-C164	EF-359342	4-F3B	ER-361094	4-R85	ET-349605	4-TR69
EC-347471	4-C77	EF-601942	4-F1C	ER-361094	4-R86	ET-349626	5-TR27
EC-350680	4-C173	EF-601942	4-F2C	ER-361096	4-R214	ET-349626	5A-TR1
EC-351980	4-C172	EF-668474	4-F3C	ES-354767	1-SW1	ET-349725	4-TR75
EC-351993	4-C68	EH-328490	4-FL2	ES-354767	1-SW2	ET-349725	4-TR29
EC-351994	4-C69	EH-328491	4-FL1	ES-354767	1-SW3	ET-349725	4-TR34
EC-352008	4-C166	EH-355320	5-IB1	ES-354767	1-SW4	ET-349725	4-TR36
EC-355371	12-C204	EH-355321	5-IB2	ES-354849	2-SW904	ET-349725	4-TR37
EC-356994	4-C81	EH-355323	5-IB5	ES-354850	2-SW902	ET-349883	4-TR26
EC-357784	4-C76	EH-356520	5-IB4	ES-354850	2-SW903	ET-349883	4-TR27
EC-360693	4-C162	EI-304657	6-IC301	ES-355227	4-SW1	ET-350795	5-TR1
ED-301911	4-D10	EI-305456	4-IC8	ES-355332	7-SW101	ET-350795	5-TR2
ED-301911	4-D24	EI-337008	5-IC3	ES-355332	7-SW111	ET-350795	5-TR7
ED-301911	4-D31	EI-337009	5-IC4	ES-355604	7-SW102	ET-350795	5-TR8
ED-301911	4-D32	EI-337013	5-IC5	ES-355604	7-SW103	ET-350795	5-TR10
ED-301911	4-D33	EI-337013	5-IC7	ES-355604	7-SW104	ET-350795	5A-TR2
ED-301911	4-D34	EI-337228	4-IC4	ES-355604	7-SW105	ET-350795	5A-TR3
ED-301911	4-D35	EI-338171	5-IC6	ES-355604	7-SW106	ET-350795	5-TR30
ED-301911	4-D36	EI-349196	4-IC12	ES-355604	7-SW107	ET-350795	6-TR301
ED-301911	4-D42	EI-349372	5-X1	ES-355604	7-SW108	ET-350795	6-TR303
ED-301911	5-D6	EI-353227	4-IC11	ES-355604	7-SW109	EV-336785	4-VR4
ED-301911	5-D7	EI-354822	4-IC9	ES-355604	7-SW110	EV-338462	4-VR9
ED-301911	5-D8	EI-355115	4-IC13	ES-358581	12-SW2	EV-338463	4-VR5
ED-301911	5-D9	EI-355134	4-IC10	ES-359606	13-VS901	EV-338464	4-VR8
ED-301911	5-D11	EI-355350	5-IC1	ET-308141	4-TR46	EV-355231	7-VR102
ED-301911	5-D13	EI-355602	5-IC2	ET-308141	5-TR3	EV-355232	4-VR1
ED-301911	5A-D2	EI-356327	7-IC101	ET-308141	5-TR4	EV-355380	4-VR7
ED-301911	5-D15	EI-357498	4-IC7	ET-308141	5-TR29	EV-355389	7-VR101
ED-301911	5-D16	EJ-346076	4-J2	ET-308472	4-TR47	EV-356576	4-VR3
ED-301911	5-D43	EJ-347664	4-J1A	ET-308472	5-TR5	EV-356579	4-VR2
ED-301911	5-D48	EJ-348846	10-J3	ET-308472	5-TR6	EV-357837	4-VR6
ED-301911	5-D49	EJ-361072	4-J1B	ET-310148	4-TR48	EV-522652	5-VR1
ED-301911	5-D50	EM-355326	7-IN1	ET-310148	4-TR19	EW-355312	13-4A
ED-301911	5-D51	EO-315758	4-FL3	ET-310148	5-TR28	EW-355315	13-4D
ED-301911	5-D52	EO-337044	4-FL4	ET-316523	4-TR40	EW-355316	13-4E
ED-301911	5-D54	EO-337055	4-L2	ET-338324	4-TR71	EW-355317	13-4F
ED-301911	6-D301	EO-355136	4-T1	ET-345091	11-PH100	EW-355318	13-4C

INDEX

PART NO.	REF. NO.	PART NO.	REF. NO.	PART NO.	REF. NO.	PART NO.	REF. NO.
EW-355521	13-4B	MZ-354733	2-13	SP-355354D	13-7D	ZS-455207	13-9
EZ-361283	13-5	MZ-354734	1-32	SP-355354E	13-7E	ZS-460440	1-37
HZ-344093	1-17	MZ-354737	2-29	SZ-354719	2-23	ZS-477876	2-28
HZ-354673	1-8	MZ-354762	2-30	SZ-355243	14-2	ZS-592378	2-32
HZ-354675	1-10	SA-349332	13-1	ZG-336615	1-14	ZW-270088	2-9
HZ-354676	1-11	SE-359322A	14-16	ZG-344012	1-18	ZW-300885	2-5
HZ-354764B	1-7	SE-359322B	14-16B	ZG-354718	1-38	ZW-305546	1-34
MB-354707	2-17	SK-343017F	14-3B	ZG-354745	1-12	ZW-340648	2-6
MH-354679	1-35	SK-343017G	14-3	ZG-354747	2-12	ZW-343120	1-40
MI-354706	2-15	SK-355246C	14-9	ZG-354749	1-21	ZW-343120	2-27
ML-B354710	2-21	SK-355246D	14-9B	ZG-354750	1-24	ZW-354674	1-9
ML-B354723	1-31	SK-355247A	14-14	ZG-354751	1-25	ZW-536466	2-16
ML-354685	2-7	SK-355247B	14-14B	ZG-354752	1-26	ZW-618884	1-19
ML-354691	2-10	SK-355248A	14-12	ZG-354753	1-27	ZW-698308	13-6
ML-354692	2-11	SK-355248B	14-12B	ZG-354757	2-24		
ML-354699	1-2	SK-355249A	14-13	ZG-354759	2-26		
ML-354700	1-3	SK-355249B	14-13B	ZG-355016	2-14		
ML-354701	1-4	SK-355250A	14-7	ZG-355133	1-41		
ML-354754	1-29	SK-355250B	14-7B	ZG-355238	14-4		
MR-B354695	2-33	SK-355254C	14-8	ZG-357749	1-30		
MR-359138	1-36	SK-355254D	14-8B	ZG-357808	1-33		
MT-349681	1-39	SP-344591A	14-15	ZG-359409	1-28		
MZ-B354689	2-8	SP-344591D	14-15B	ZS-304022	13-3		
MZ-B354735	2-1	SP-355255A	14-6	ZS-320906	14-11x		
MZ-344099	2-19	SP-355255B	14-6B	ZS-328606	2-22		
MZ-354682	2-2	SP-355259	14-5	ZS-343113	2-25		
MZ-354683	2-3	SP-355259B	14-5B	ZS-344001	1-20		
MZ-354684	2-4	SP-355354A	13-7A	ZS-344754	13-2		
MZ-354709	2-18	SP-355354B	13-7B	ZS-352120	13-8		
MZ-354715	2-20	SP-355354C	13-7C	ZS-417161	1-15		

AKAI

MODEL GX-R60

SCHEMATIC DIAGRAM AND PC BOARDS

TABLE OF CONTENTS

1. SCHEMATIC DIAGRAM OF ICs	2
2. PRE AMP AND POWER SUPPLY BLOCK DIAGRAM.....	4
3. SYSTEM CONTROL (A) BLOCK DIAGRAM	5
4. CONNECTION DIAGRAM.....	6
5. METER PC BOARD AND OTHER PC BOARDS.....	7
6. SYSTEM CONTROL (A) SCHEMATIC DIAGRAM.....	8
7. SYSTEM CONTROL (A) PC BOARD, LOADING PC BOARD.....	9
8. PRE AMP AND POWER SUPPLY SCHEMATIC DIAGRAM	10
9. PRE AMP AND POWER SUPPLY PC BOARD.....	11

M50740A-430SP

PIN	SYMBOL	DESCRIPTION
1	P2 ₇	REEL ROTATION SIGNAL from PHOTO SENSOR (L)
2	P2 ₆	REEL ROTATION SIGNAL from PHOTO SENSOR (R)
3	P2 ₅	GX-R70 → Connected to +5V GX-R60 → Connected to GND
4	P2 ₄	} Digit Signal Output
5	P2 ₃	
6	P2 ₂	
7	P2 ₁	
8	P2 ₀	
9	NC	NO Connection
10	P0 ₇	} KEY input
11	P0 ₆	
12	P0 ₅	
13	P0 ₄	
14	P0 ₃	REC/P.B SELECT SIGNAL OUTPUT REC → "L" P.B → "H"
15	P0 ₂	P.B MUTE Control SIGNAL OUTPUT P.B MUTE → "L"
16	P0 ₁	REC MUTE Control SIGNAL OUTPUT REC MUTE → "L"
17	P0 ₀	BIAS OSC Control SIGNAL OUTPUT ON → "L" OFF → "H"
18	CNTR	Connect to Ground
19	INT	Connect to +5V
20	NC	No Connection
21	CNVSS	Connect to Ground
22	RESET	RESET SIGNAL INPUT Terminal
23	X IN	Terminal for X'tal signal
24	X OUTF	No Connection
25	X OUTS	Terminal for X'tal signal
26	VSS	Connect to ground
27	R3	} DATA input from ROTARY ENCODER
28	R2	
29	R1	
30	R0	
31	0	} Connect to Ground
32	R/W	
33	CE	
34	RESET OUT	
35	P1 ₇	Output REC PLAY MODE SIGNAL to CRLP Micom (GX-R70 only)
36	P1 ₆	Output REC PAUSE MODE SIGNAL to CRLP Micom (GX-R70 only)
37	P1 ₅	CAM MOTOR Forward drive output
38	P1 ₄	CAM MOTOR Reverse drive output
39	P1 ₃	REEL MOTOR Forward drive output
40	P1 ₂	REEL MOTOR Reverse drive output
41	P1 ₁	} REEL MOTOR Drive Control output
42	P1 ₀	
43	P3 ₇	Music interval signal input (At IPLS MODE)
44	P3 ₆	} 7 Segment drive output
45	P3 ₅	
46	P3 ₄	
47	P3 ₃	
48	P3 ₂	
49	P3 ₁	
50	P3 ₀	
51	NC	No Connect
52	Vcc	+5V

LB1649

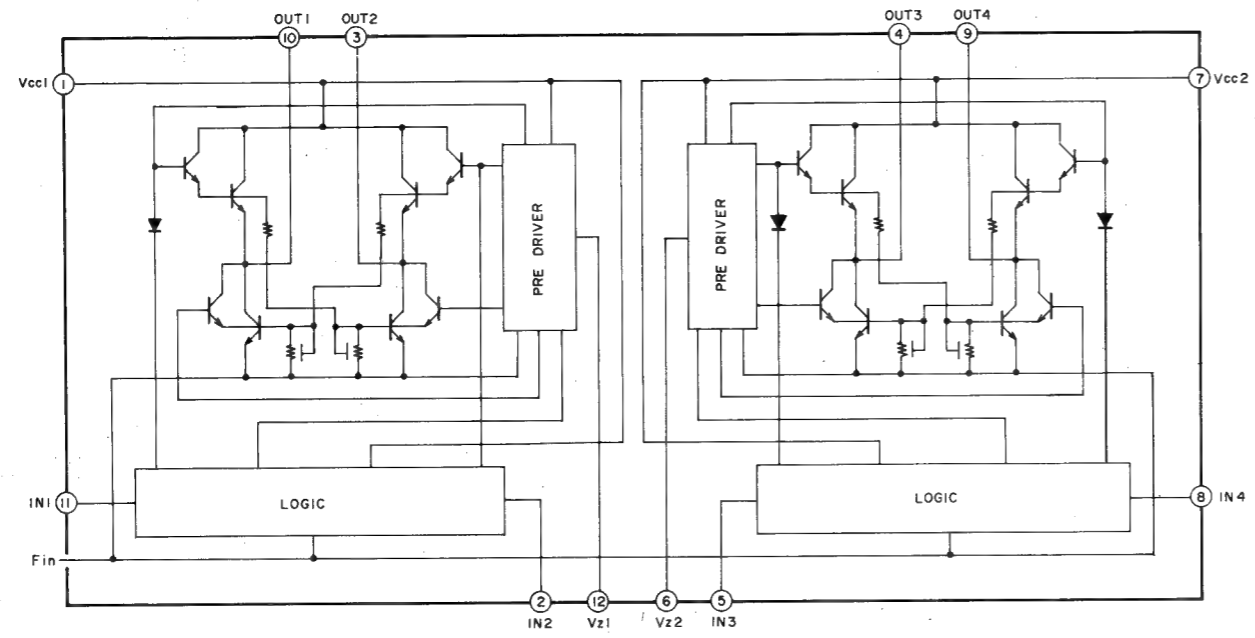

LC7800

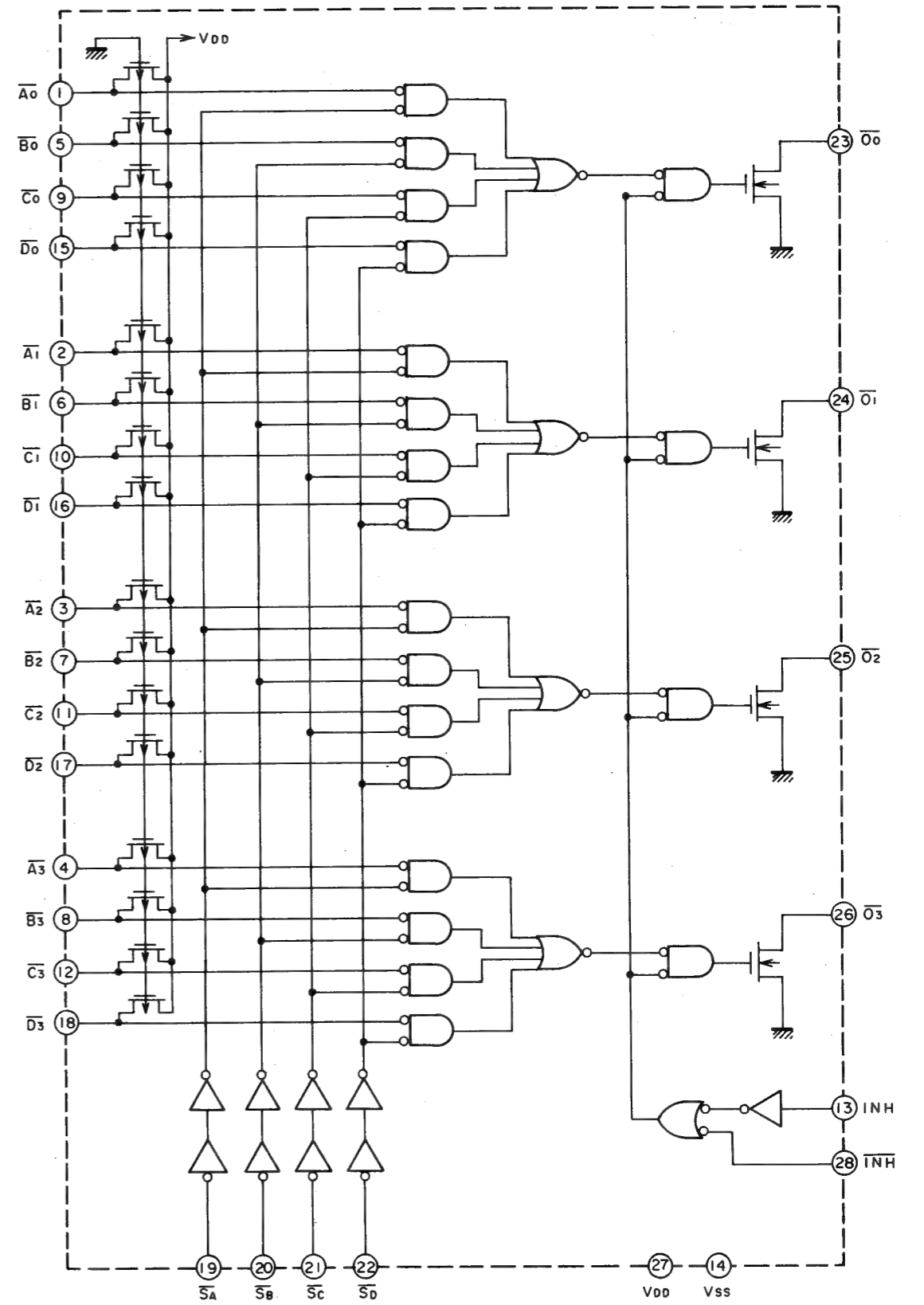

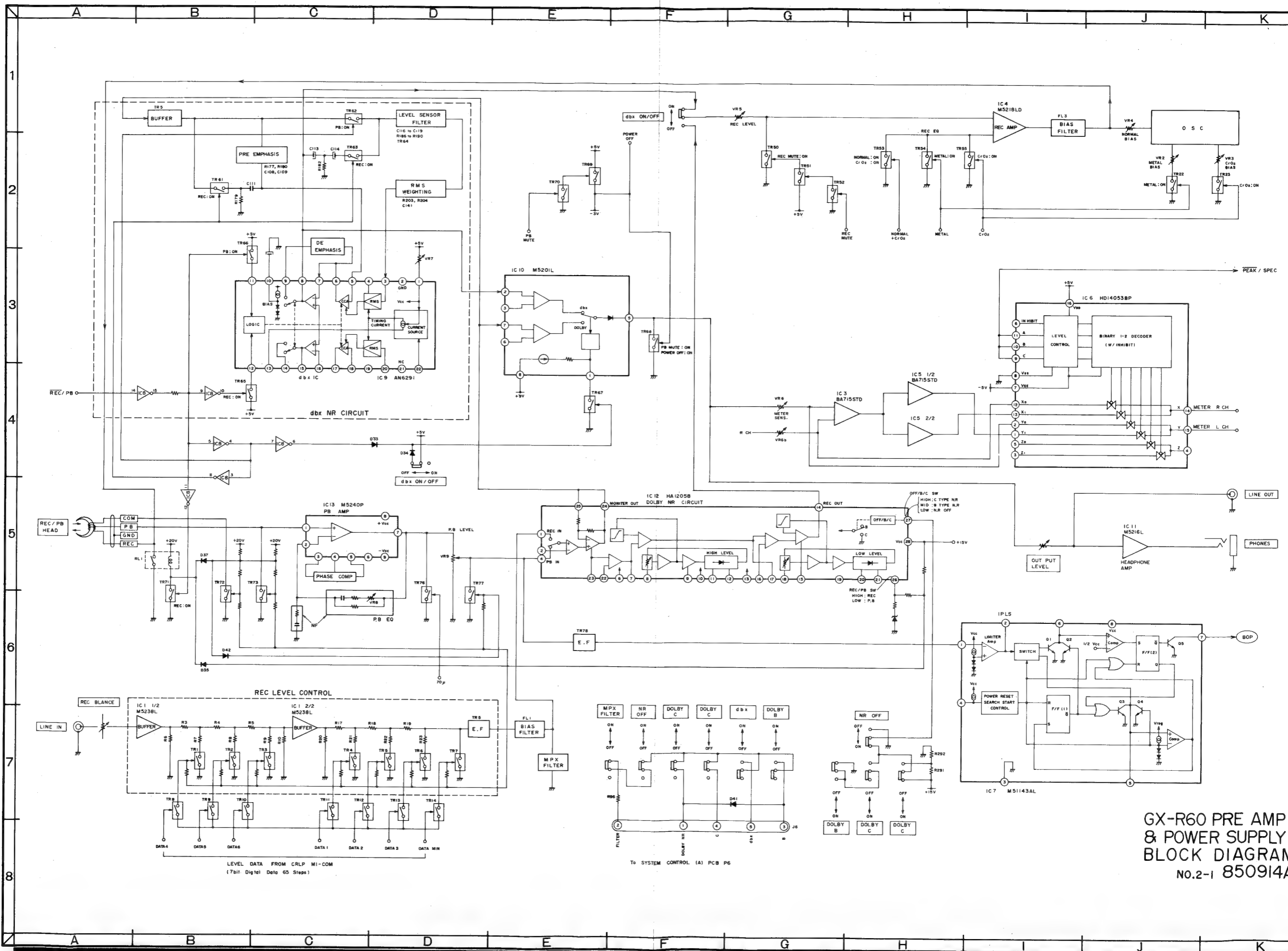

GX-R60 PRE AMP
 & POWER SUPPLY
 BLOCK DIAGRAM
 NO.2-1 850914A

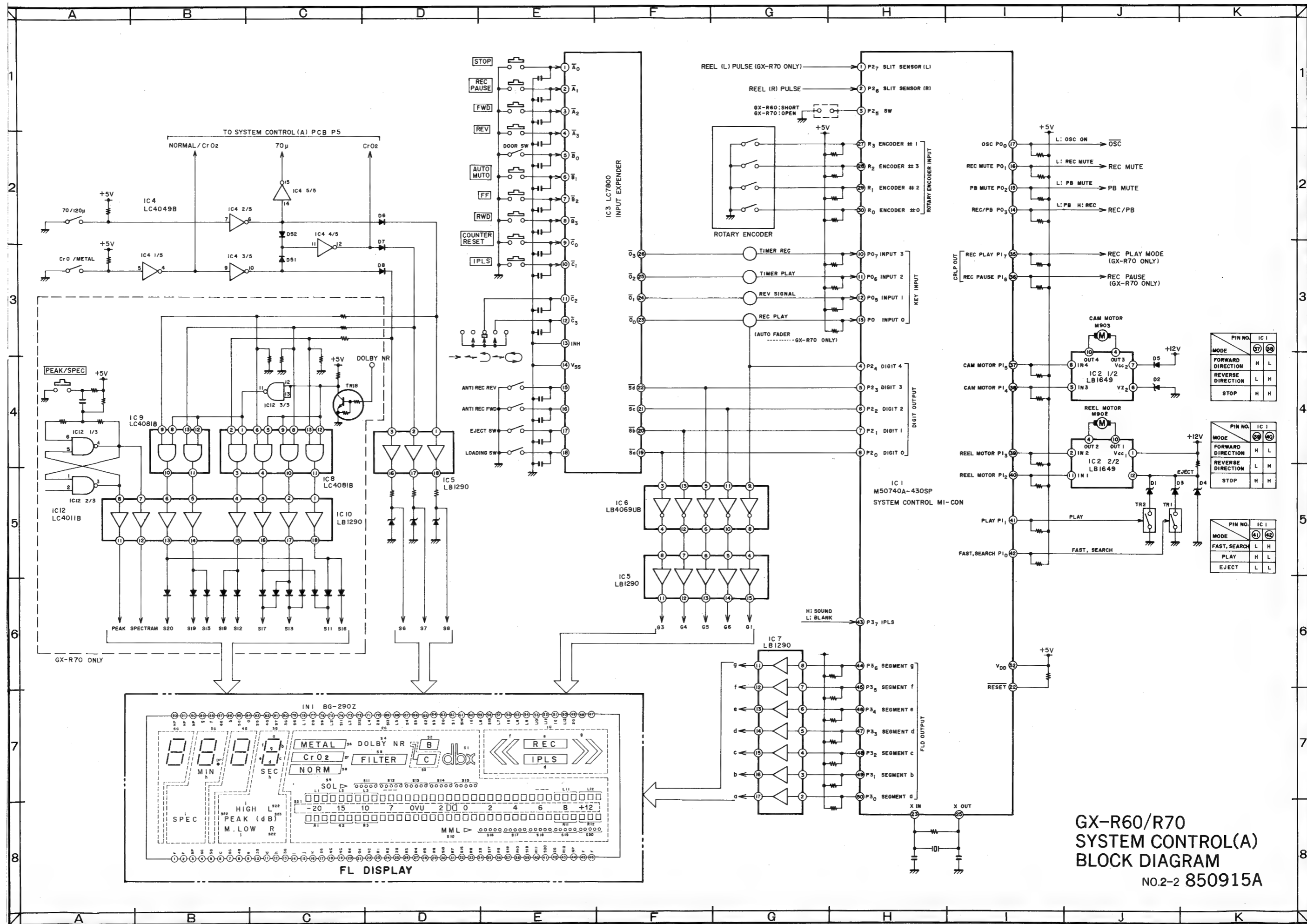

**GX-R60/R70
SYSTEM CONTROL(A)
BLOCK DIAGRAM**
NO.2-2 850915A

PIN NO.		IC 1	
MODE	(37)	(38)	
FORWARD DIRECTION	H	L	
REVERSE DIRECTION	L	H	
STOP	H	H	

PIN NO.		IC 1	
MODE	(39)	(40)	
FORWARD DIRECTION	H	L	
REVERSE DIRECTION	L	H	
STOP	H	H	

PIN NO.		IC 1	
MODE	(41)	(42)	
FAST, SEARCH	L	H	
PLAY	H	L	
EJECT	L	L	

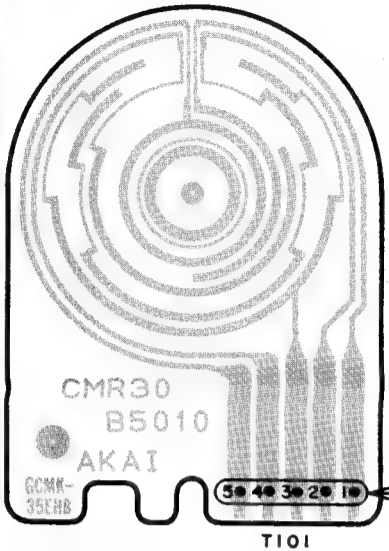

ロータリー エンコーダー基板
ROTARY ENCODER PCB
CMR30B5010

ガイド検出基板
GUIDE DETECTOR PCB
CMR01B0050

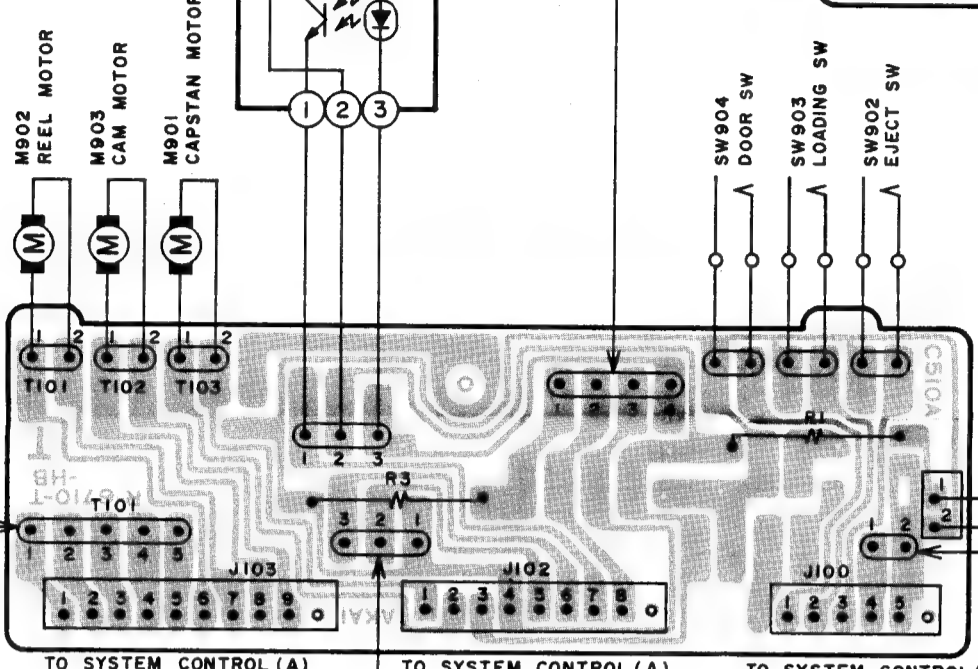
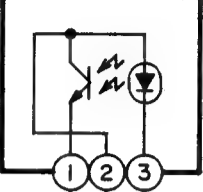

コントロール(B)A基板
CNTROL(B) A PCB
CMR30C510A

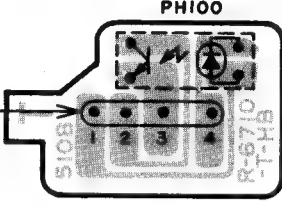

コントロール(B)B基板
CNTROL(B) B PCB
CMR30C510B

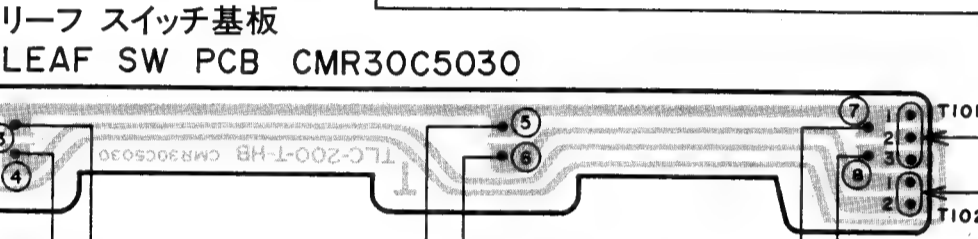

リーフ スイッチ基板
LEAF SW PCB CMR30C5030

ANTI REC (FWD) SW SW1

70μ/120μ SW SW3

C₁ O₂/METAL SW SW2

ANTI REC (REV) SW SW4

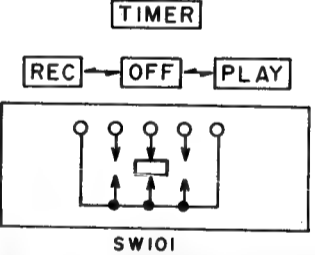

TIMER

SW101

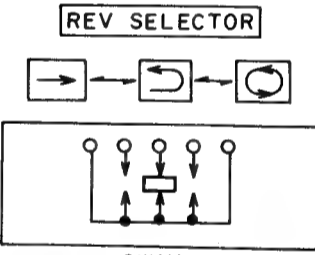

REV SELECTOR

SW111

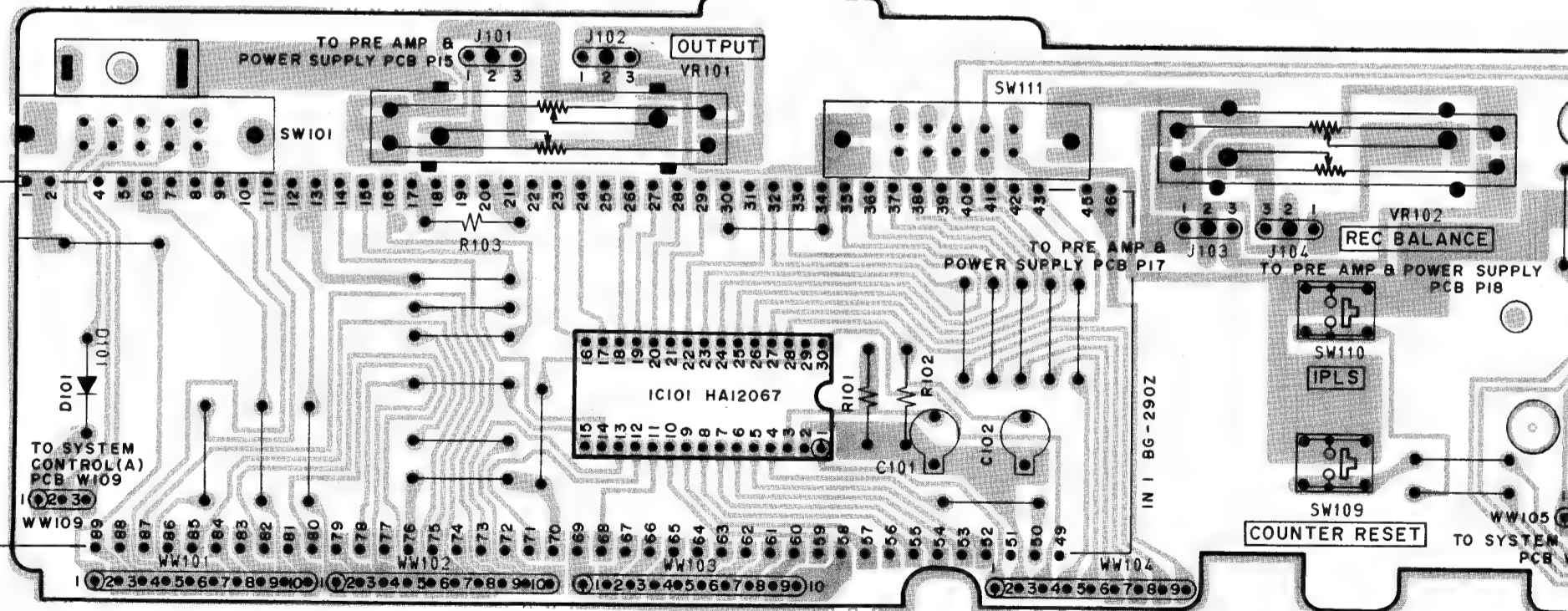

TO SYSTEM CONTROL (A) PCB W101

TO SYSTEM CONTROL (A) PCB W102

TO SYSTEM CONTROL (A) PCB W103

TO SYSTEM CONTROL (A) PCB W104

METER PCB
メーター基板

AKAI
T2074

(B) B基板
 (B) B PCB
 510B

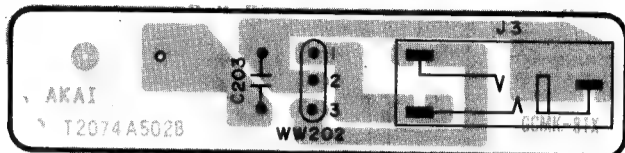

ヘッドホン基板
 HEAD PHONE PCB
 T2074A502B

TO PRE AMP B
 POWER SUPPLY PCB W202

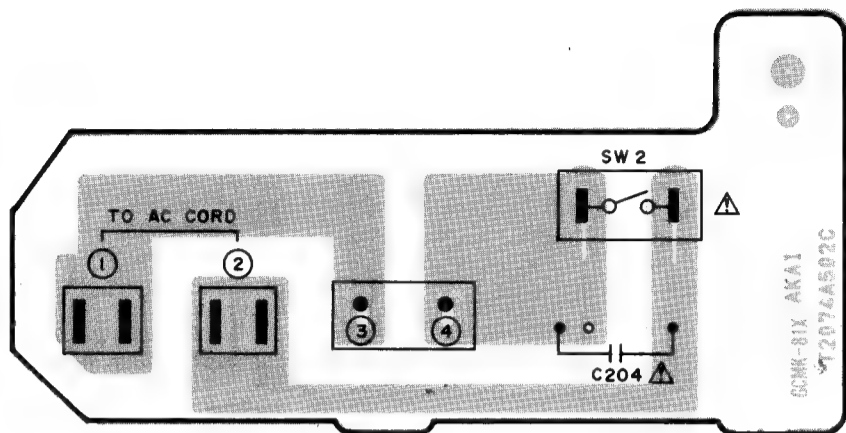

POWER SW PCB T2074A502C
 電源スイッチ基板

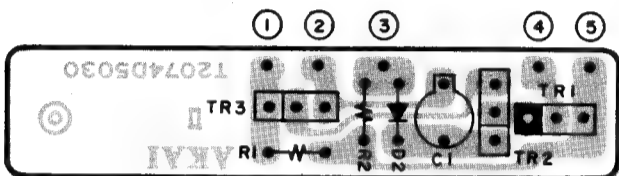

TR1 --- 2SA1347
 TR2,3 -- 2SC3399

LOADING PCB T2074D5030
 ローディング基板

注意: △の付された部品は、安全上重要部品です。交換の際は、指定部品以外は使用しないこと。
 WARNING: △ INDICATES SAFETY CRITICAL COMPONENTS. FOR CONTINUED SAFETY, REPLACE SAFETY CRITICAL COMPONENTS ONLY WITH MANUFACTURER'S RECOMMENDED PARTS.
 AVERTISSEMENT: △ IL INDIQUE LES COMPOSANTS CRITIQUES DE SURETE. POUR MAINTENIR LE DEGRE DE SECURITE DE L'APPAREIL, NE REMPLACER LES COMPOSANTS DONT LE FONCTIONNEMENT EST CRITIQUE POUR LA SECURITE QUE PAR DES PIECES RECOMMANDEES PAR LE FABRICANT.

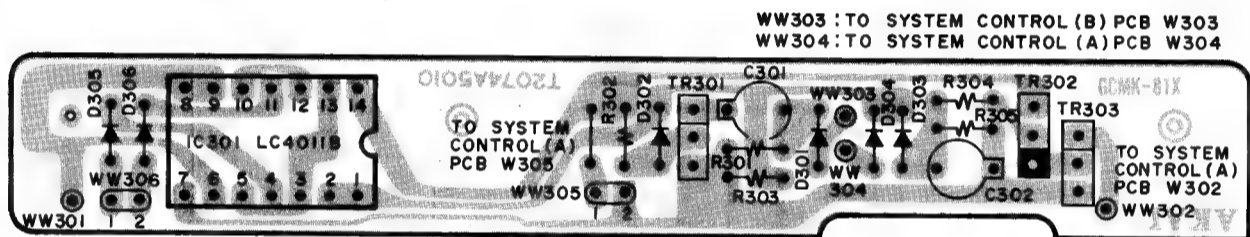

WW301: TO SYSTEM CONTROL (A) PCB W301
 WW306: TO SYSTEM CONTROL (A) PCB W306

SYSTEM CONTROL (D) PCB T2074A5010
 システム コントロール(D)基板



TR301, 303 --- 2SC3399
 TR302 --- 2SA1345

B
 ●●● = NPN TRANSISTOR
 B
 ●●● = PNP TRANSISTOR

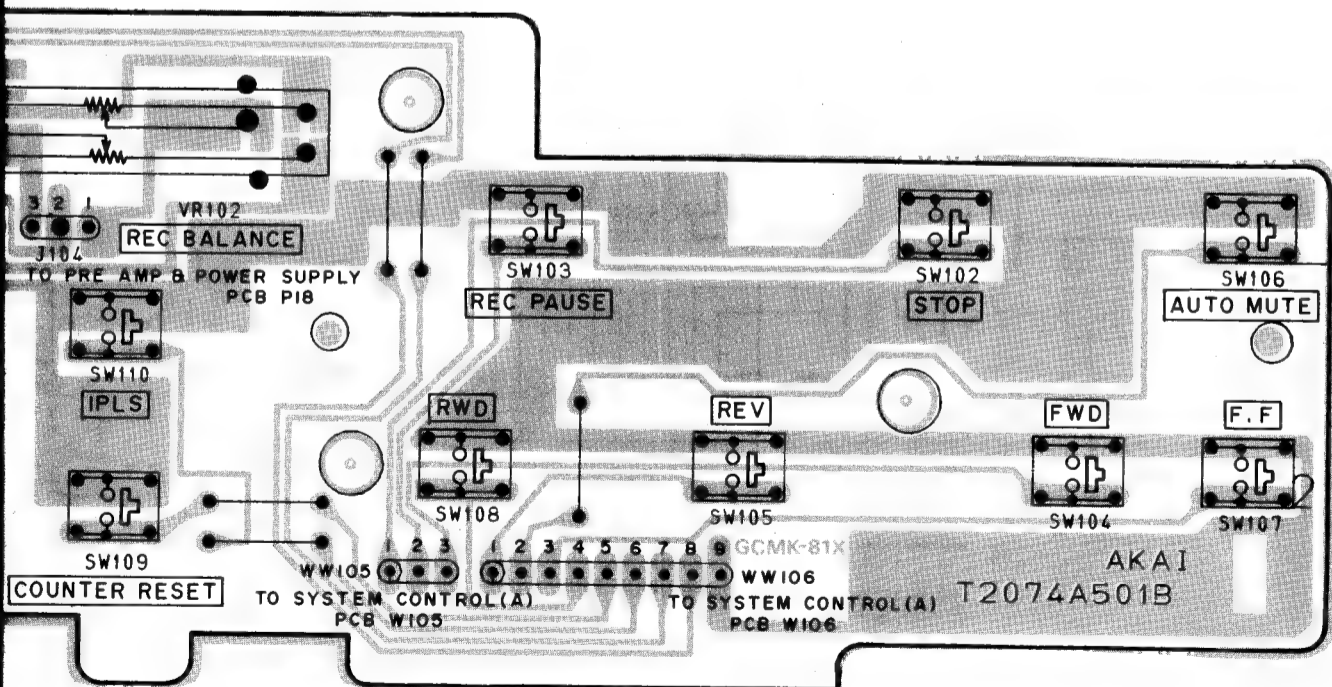

METER PCB T2074A501B
 メーター基板

05

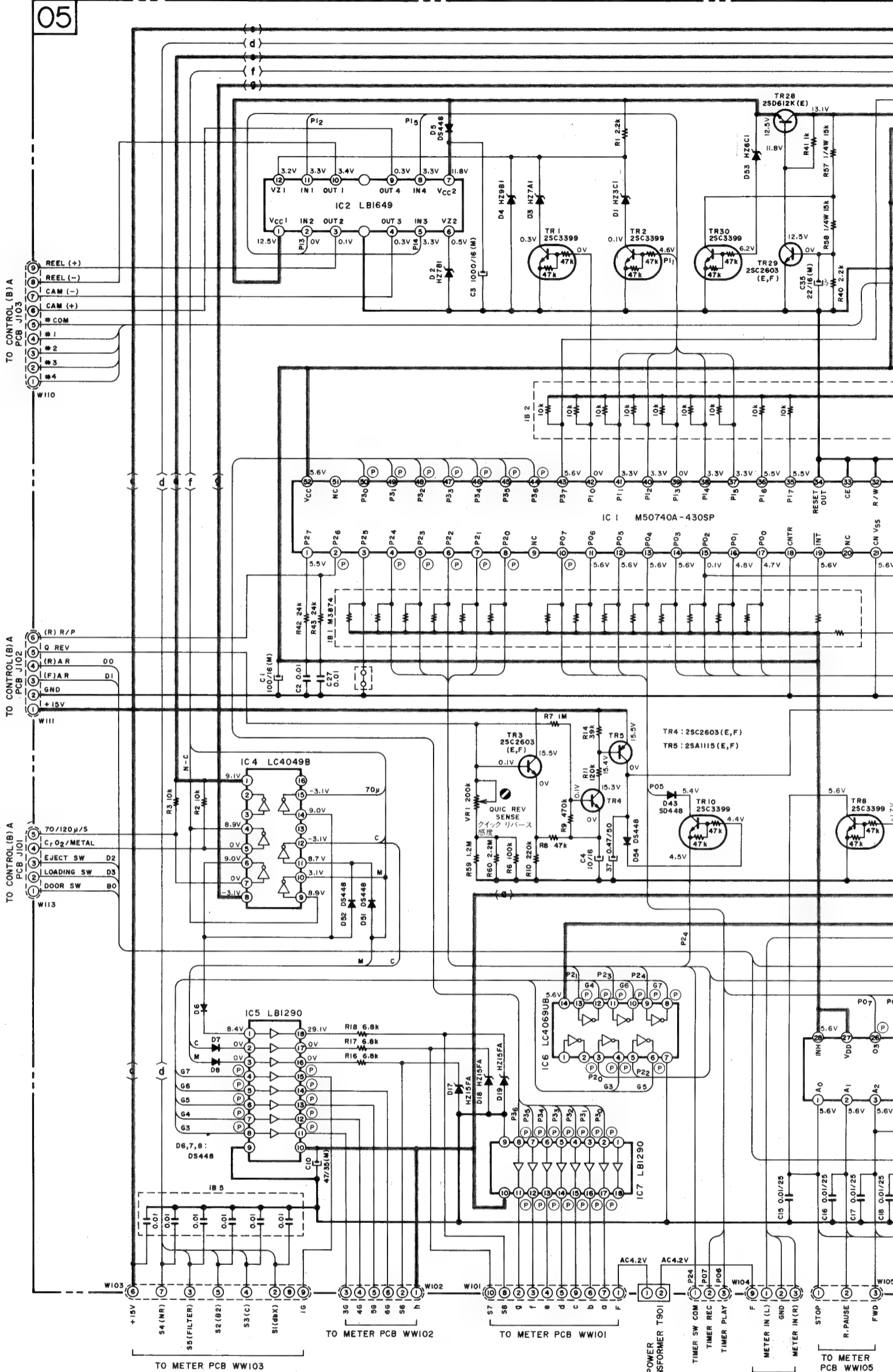

TO CONTROL (B) A
PCB J103

REEL (+)
REEL (-)
CAM (-)
CAM (+)
COM
#1
#2
#3
#4
W110

TO CONTROL (B) A
PCB J101

(R) R/P
Q REV
(R) A R DO
(F) A R DI
GND
+15V
W111

TO CONTROL (B) A
PCB J101

70/120μ/5
C₇ O₂/METAL
EJECT SW D2
LOADING SW D3
DOOR SW B0
W113

TO METER PCB WW103

TO METER PCB WW102

TO METER PCB WW101

TO METER PCB WW104

TO METER PCB WW105

— : B (POWER SUPPLY) LINE
: B電源

VOLTAGE INDICATED AT P.B MODE (DOLBY OFF)
(P) INDICATED AT PULSE SIGNAL

各電圧は再生時(ドルビーオフ)の電圧値を示します。
Pはパルス信号を示します。

NOTE
UNLESS OTH
ALL RESISTO
ALL CAPACIT

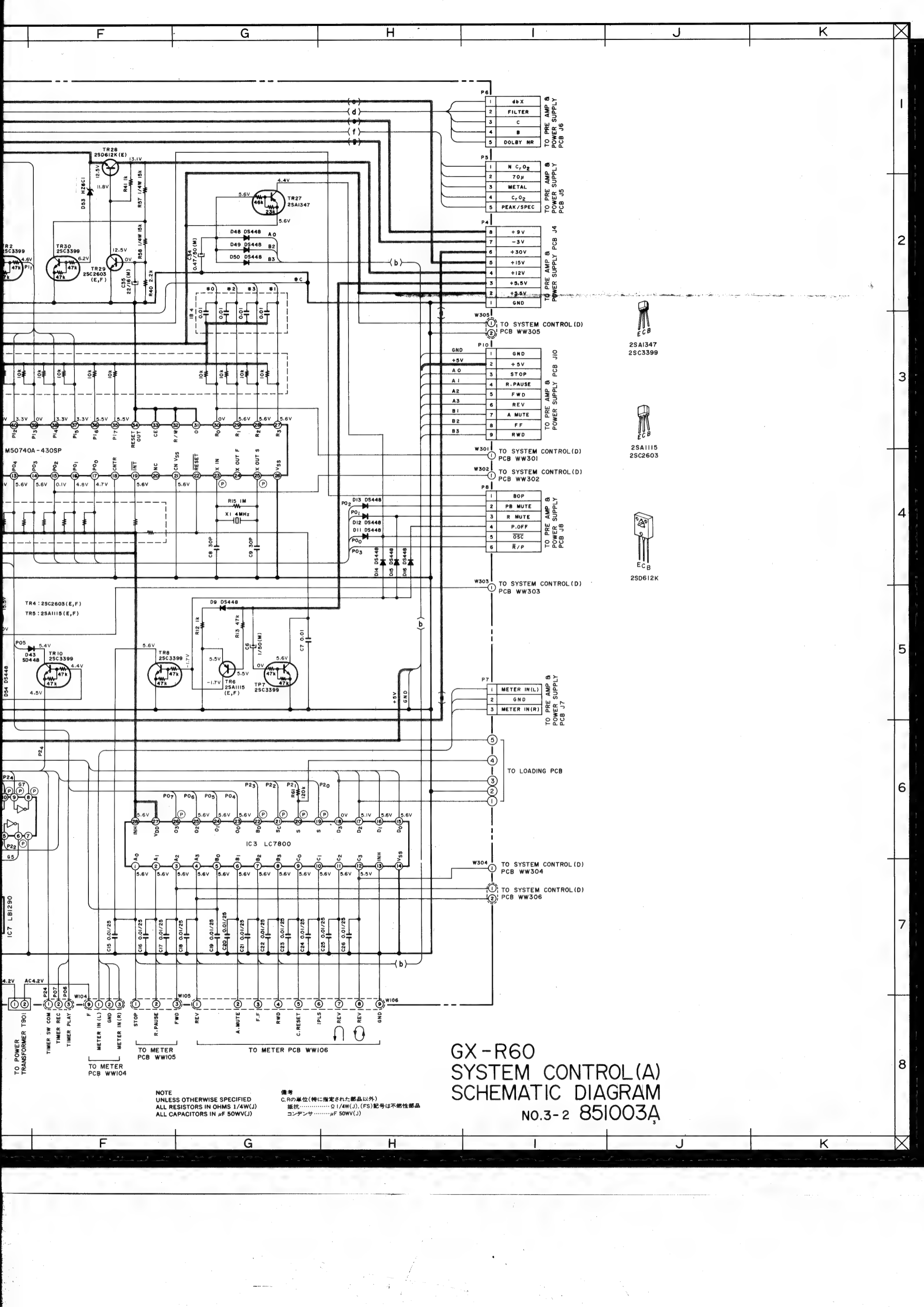

NOTE
UNLESS OTHERWISE SPECIFIED
ALL RESISTORS IN OHMS 1/4W(J)
ALL CAPACITORS IN μ F 50WV(J)

備考
C, Rの単位(特に指定された部品以外)
抵抗…………… Ω 1/4W(J), (FS)記号は不燃性部品
コンデンサ…………… μ F 50WV(J)

GX-R60
SYSTEM CONTROL (A)
SCHEMATIC DIAGRAM
No.3-2 851003A

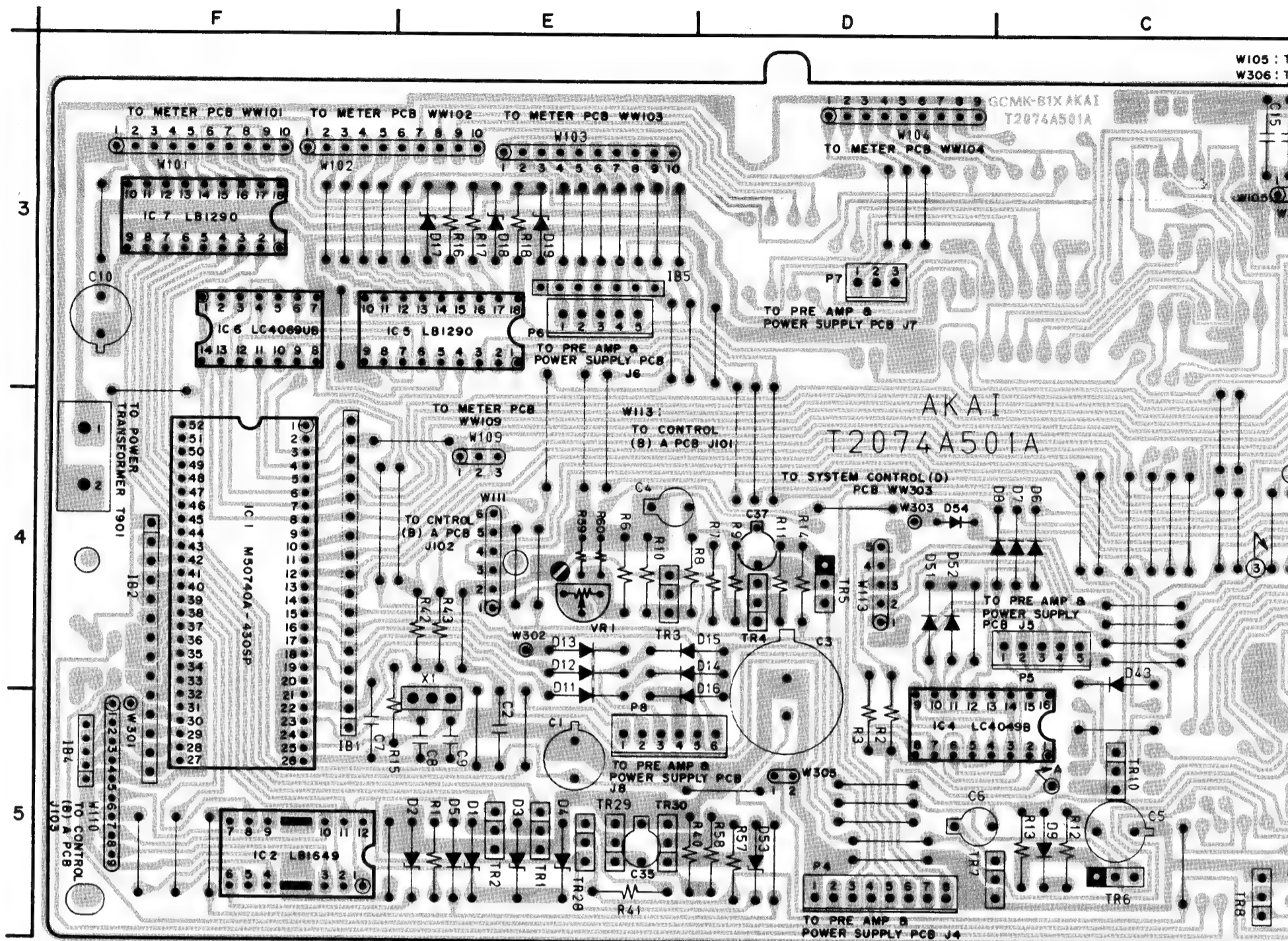

W301: TO SYSTEM CONTROL (D)
PCB WW301

W302: TO SYSTEM CONTROL (D)
PCB WW302

W305: TO SYSTEM CONTROL (D)
PCB WW305



2SA1347
2SC3399



2SA1115
2SC2603



2SD612K

VRI : QUICK REV SENS ADJ

= NPN TRANSISTOR
 = PNP TRANSISTOR

TRI, 2, 7, 8, 10, 30 --- 2SC3399
 TR3, 4, 29 ----- 2SC2603
 TR5, 6 ----- 2SA1115
 TR27 ----- 2SA1347
 TR28 ----- 2SD612K

SYS
シス

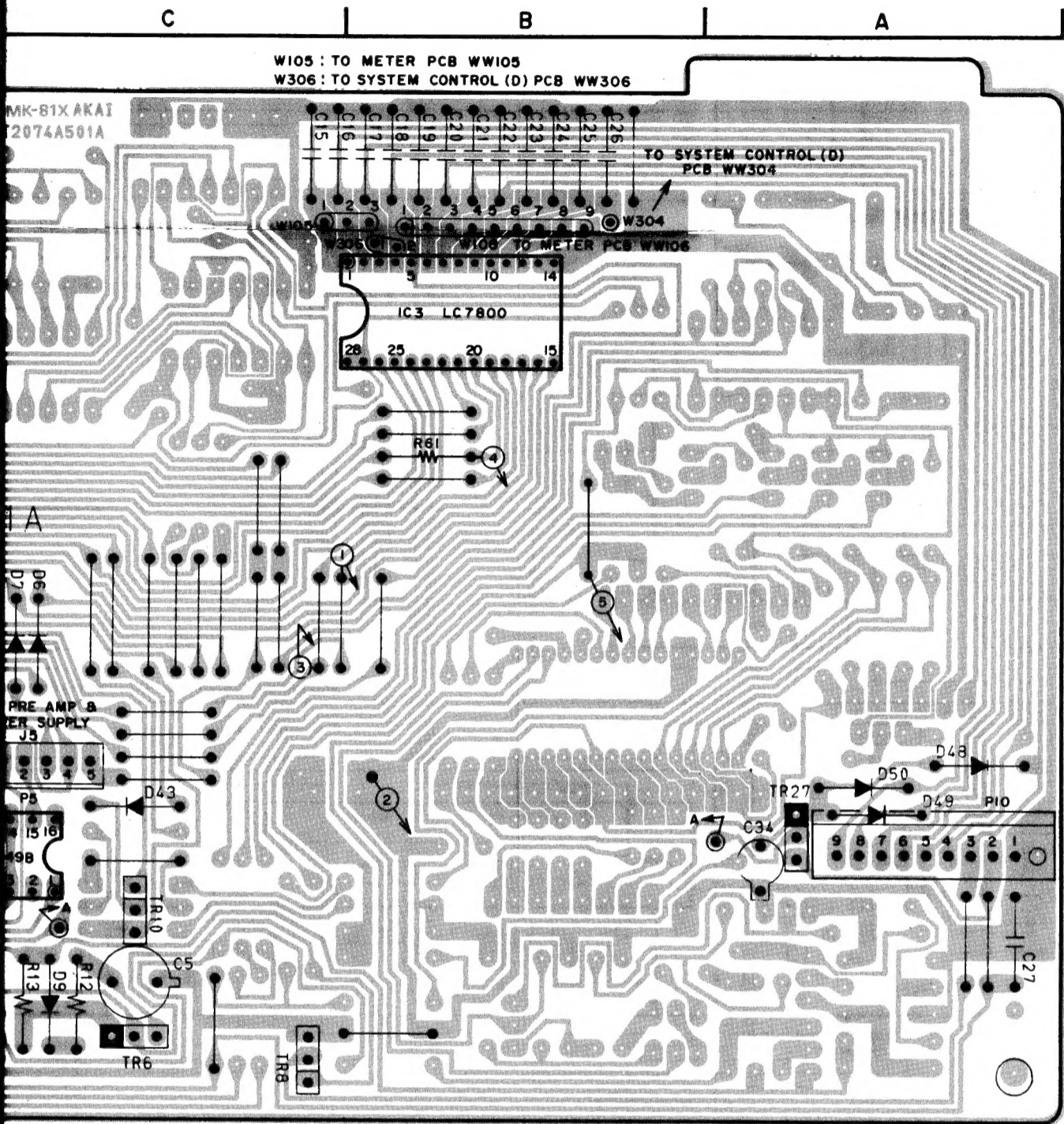

SYSTEM CONTROL (A) PCB T2074A501A
システム コントロール(A)基板

LOCATION OF COMPONENTS

- ICs
 IC1.....F4
 IC2.....F5
 IC3.....B3
 IC4.....C5, D5
 IC5.....E3
 IC6.....F3
 IC7.....F3

- TRs
 TR1.....E5
 TR2.....E5
 TR3.....E4
 TR4.....D4
 TR5.....D4
 TR6.....C5
 TR7.....C5
 TR8.....C5
 TR10....C5
 TR27....A5
 TR28....E5
 TR29....E5
 TR30....E5

CONNECTORS

- P4.....D5
 P5.....C4
 P6.....E3
 P7.....D3
 P8.....E5
 P10....A5

- TR1,2,7, 8,10, 30 -- 2SC3399
 TR3,4,29 ----- 2SC2603(E, F)
 TR5,6 ----- 2SA1115(E, F)
 TR27 ----- 2SA1347
 TR28 ----- 2SD612K

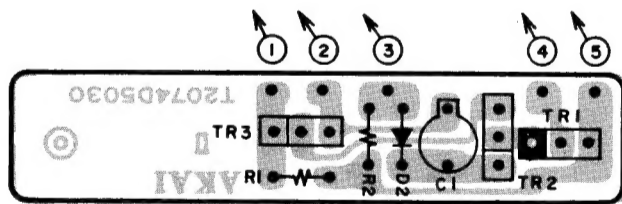

LOADING PCB T2074D5030
ローディング基板

- TR1 ---- 2SA1347
 TR2,3 -- 2SC3399

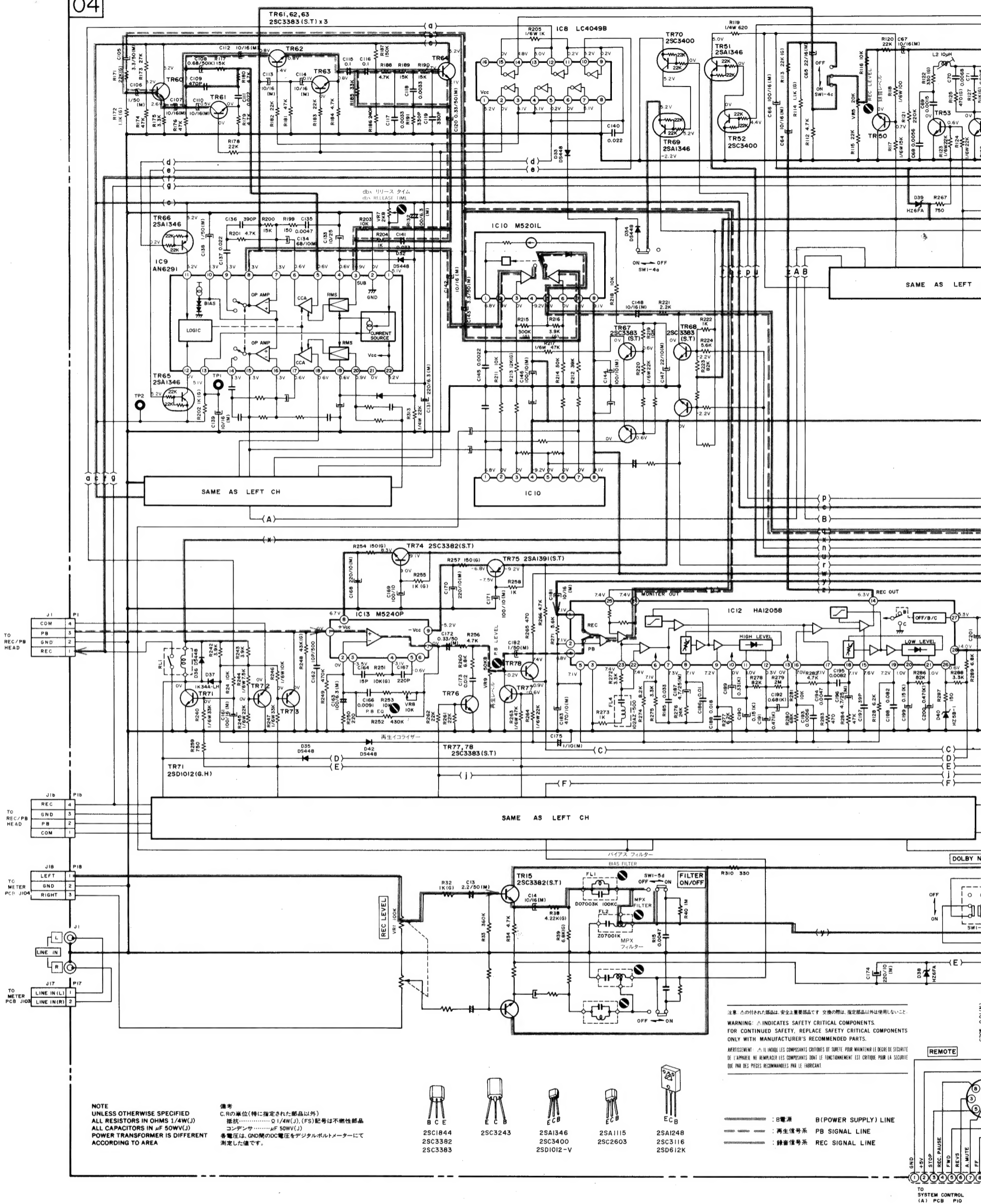

NOTE
UNLESS OTHERWISE SPECIFIED
ALL RESISTORS IN OHMS 1/4W(J)
ALL CAPACITORS IN μF 50WV(J)
POWER TRANSFORMER IS DIFFERENT
ACCORDING TO AREA

備考
C.R.の単位(特に指定された部品以外)
抵抗……………Ω 1/4W(J), (FS)記号は不燃性部品
コンデンサ……………μF 50WV(J)
各電圧は、GND間のDC電圧をデジタルマルチメーターにて
測定した値です。

- B C E
 - F C B
 - E C B
 - E C B
 - E C B
 - E C B
- 25C1844
25C3382
25C3383
- 25C3243
- 25A1346
25C3400
25D1012-V
- 25C2603
- 25A1248
25C3116
25D612K

注意: △の付いた部品は、安全上重要部品です。交換の際は、指定部品以外は使用しないでください。
WARNING: △ INDICATES SAFETY CRITICAL COMPONENTS. FOR CONTINUED SAFETY, REPLACE SAFETY CRITICAL COMPONENTS ONLY WITH MANUFACTURER'S RECOMMENDED PARTS.
AVERTISSEMENT: △ IL INDIQUE LES COMPOSANTS CRITIQUES DE SURETE. POUR MAINTENIR LE DEGRE DE SECURITE DE L'APPAREIL, NE REMPLACER LES COMPOSANTS DONT LE FONCTIONNEMENT EST CRITIQUE POUR LA SECURITE QUE PAR DES PIECES RECOMMANDEES PAR LE FABRICANT.

—●— : 8電源 B(POWER SUPPLY) LINE
—○— : 再生信号系 PB SIGNAL LINE
—□— : 録音信号系 REC SIGNAL LINE

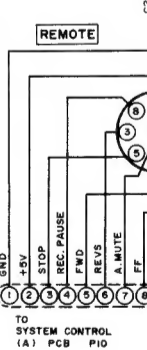

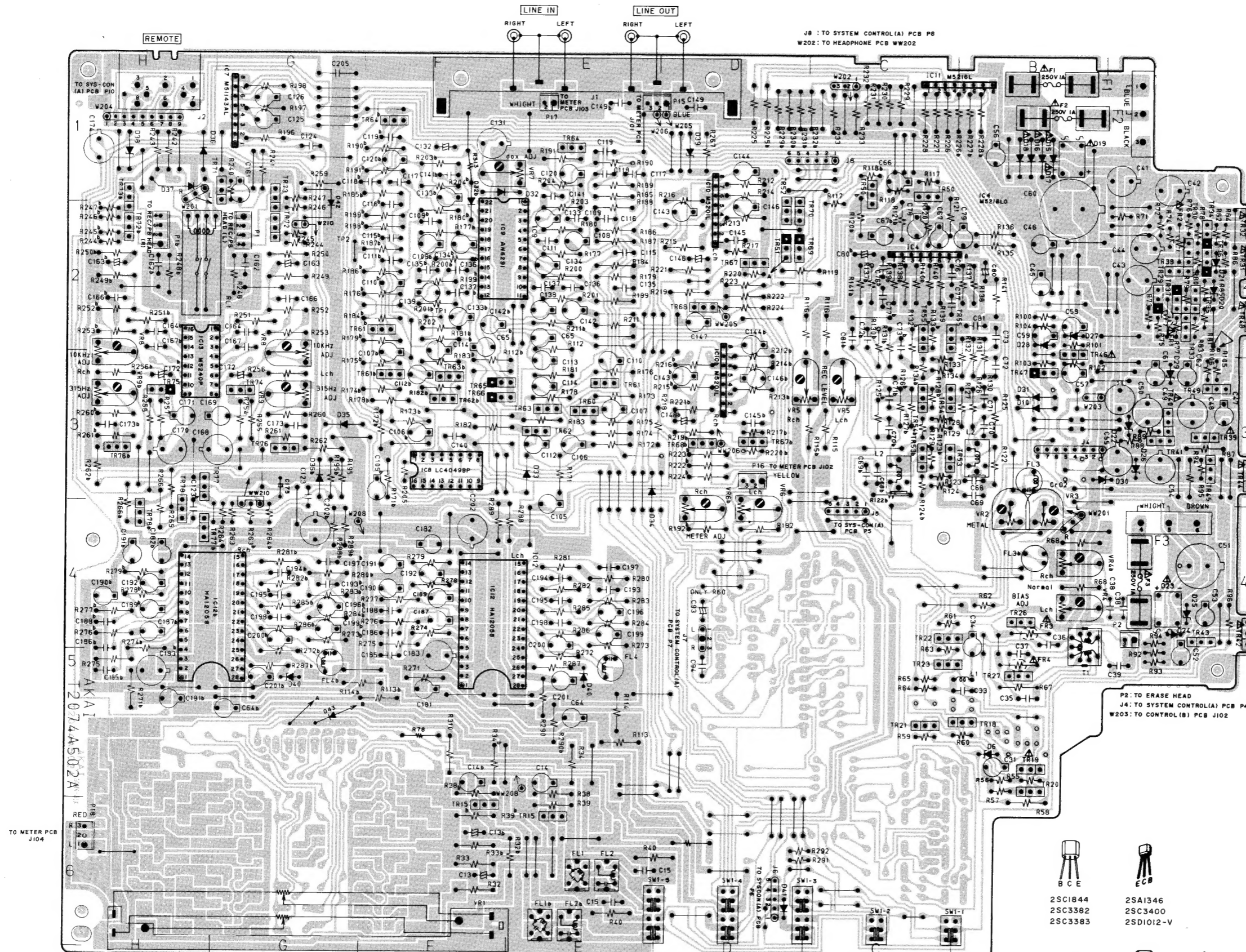

VR2...METAL BIAS ADJ
 VR3...C02 BIAS ADJ
 VR4...NORMAL BIAS ADJ
 VR5...REC LEVEL ADJ
 VR6...METER SENS.ADJ
 VR7...dbx RELEASE TIME ADJ
 VR8...P.B EQ ADJ
 VR9...P.B LEVEL ADJ

PRE AMP & POWER SUPPLY PCB
T2074A502A
プリアンプ/電源基板

注意: △の付いた部品は、安全上重要部品です。交換の際は、指定部品以外は使用しないでください。
 WARNING: △ INDICATES SAFETY CRITICAL COMPONENTS. FOR CONTINUED SAFETY, REPLACE SAFETY CRITICAL COMPONENTS ONLY WITH MANUFACTURER'S RECOMMENDED PARTS.
 Avertissement: △ IL INDIQUE LES COMPOSANTS CRITIQUES DE SURETE. POUR MAINTENIR LE DEGRÉ DE SURETE DE L'APPAREIL, NE REMPLACER LES COMPOSANTS DONT LE FONCTIONNEMENT EST CRITIQUE POUR LA SURETE QUE PAR DES PIÈCES RECOMMANDÉES PAR LE FABRICANT.

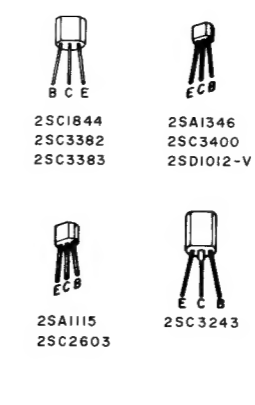
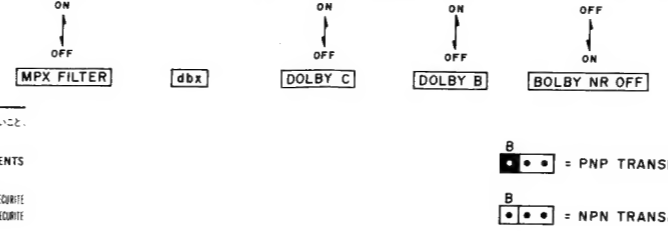

- LOCATION OF COMPONENTS**
- ICs
 IC4.....C3
 IC7.....G1
 IC8.....F3
 IC9.....F2
 IC10.....D1,D2
 IC10b...D3
 IC11.....B1,C1
 IC12.....F4
 IC12b...G4,H4
 IC13.....H2,H3
- TRs
 TR15....E6 TR54...C3
 TR15b...F6 TR54b...C3
 TR18....B5 TR55...C2
 TR19....B5 TR55b...C2
 TR20....B5 TR60...E3
 TR21....C5 TR60b...F3
 TR22....C4 TR61...E3
 TR23....C5 TR61b...E2
 TR26....B4 TR62...E3
 TR27....B5 TR62b...F3
 TR29....A2 TR63...E3
 TR30....A2 TR63b...F3
 TR31....A2 TR64...E1
 TR32....A2 TR64b...F1
 TR33....A2 TR65...F3
 TR34....A2 TR66...F3
 TR35....A2 TR67...D2
 TR36....A2 TR67b...D3
 TR37....A2 TR68...D2
 TR38....A2 TR68b...D3
 TR39....A3 TR69...D2
 TR40....A3 TR70...D2
 TR41....A3 TR71...G1
 TR42....A2 TR72...G2
 TR43....A4 TR72b...H1
 TR44....A3 TR73...H2
 TR45....A3 TR73b...H1
 TR46....B2 TR74...G3
 TR47....B3 TR75...H3
 TR48....A2 TR76...H3
 TR49....A3 TR76b...H3
 TR50....C1 TR77...H3
 TR50b...C1 TR77b...H4
 TR51....D2 TR78...H4
 TR52....D2 TR78b...H4
 TR53....C3
 TR53b...C3
- CONNECTORS**
 P1.....G2
 P1b....H2
 P2.....A4
 P15....D1,E1
 P16....D3
 P17....E1
 P18....H6
- TR15, 30, 33, 35, 38, 39,
 41, 43, 45, 53, 54, 55,
 60, 64, 72, 73, 74, 76...2SC3382 (S,T)
- TR18, 22, 23, 52, 70...2SC3400
- TR19, 48...2SD612K (E,F)
- TR20, 21, 49, 50, 61, 62,
 63, 67, 68, 77, 78...2SC3383 (S,T)
- TR26, 27...2SC3243 (D,E)
- TR29, 34, 36, 37, 75...2SA1391 (S,T)
- TR31...2SA1248
- TR32, 42, 44...2SC3116 (S,T)
- TR40...2SC1844 (F)
- TR46...2SC2603 (E,F)
- TR47...2SA1115 (E,F,G)
- TR51, 65, 66, 69...2SA1346
- TR71...2SD1012-V (H)