

AKAI SERVICE MANUAL

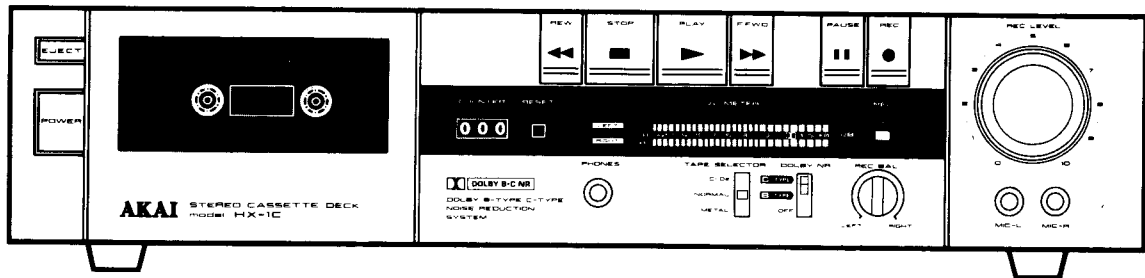

STEREO CASSETTE DECK

MODEL **HX-1C**

ABBREVIATIONS FOR SERVICE MANUAL MODEL HX-1C

ABBREVIATIONS	EXPLANATION
AC	Alternating Current
ATT	ATTenuater
DC	Direct Current
FF	Fast Forward
FREQ	FREQuency
GND	GrouND
MIC	MICrophone
NR	Noise Reduction
PB	Play Back
REC	RECORD
REW	REWind
SENS	SENSitivity

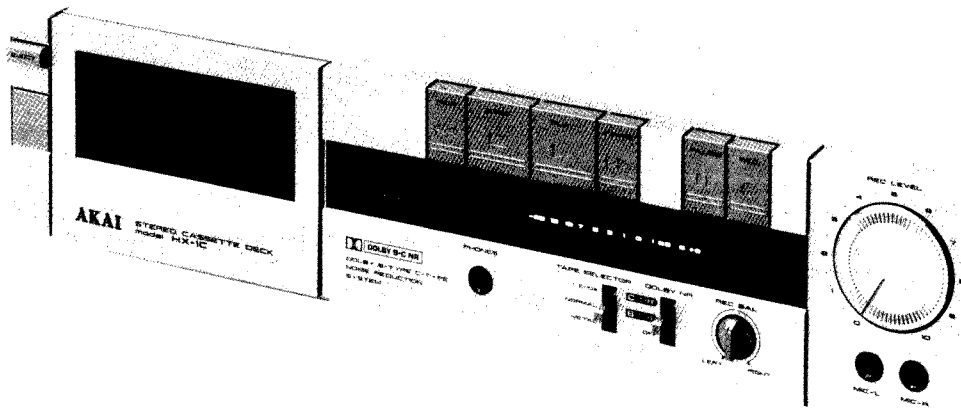

STEREO CASSETTE DECK

MODEL HX-1C

SECTION 1	SERVICE MANUAL	3
SECTION 2	PARTS LIST	15
SECTION 3	SCHEMATIC DIAGRAM	25

SAFETY INSTRUCTIONS

SAFETY CHECK AFTER SERVICING

Confirm the specified insulation resistance between power cord plug prongs and externally exposed parts of the set is greater than 10 Mohms, but for equipment with external antenna terminals (tuner, receiver, etc.) and is intended for **C** or **A**, specified insulation resistance should be more than 2.2 Mohms (ground terminals, microphone jacks, headphone jacks, line-in-out jacks etc.)

PRECAUTIONS DURING SERVICING

1. Parts identified by the **△** symbol parts are critical for safety.
Replace only with parts number specified.
2. In addition to safety, other parts and assemblies are specified for conformance with such regulations as those applying to spurious radiation. These must also be replaced only with specified replacements.
Examples: RF converters, tuner units, antenna selector switches, RF cables, noise blocking capacitors, noise blocking filters, etc.
3. Use specified internal wiring. Note especially:
 - 1) Wires covered with PVC tubing
 - 2) Double insulated wires
 - 3) High voltage leads
4. Use specified insulating materials for hazardous live parts. Note especially:
 - 1) Insulation Tape
 - 2) PVC tubing
 - 3) Spacers (Insulating Barriers)
 - 4) Insulation sheets for transistors
 - 5) Plastic screws for fixing microswitch (especially in turntable)
5. When replacing AC primary side components (transformers, power cords, noise blocking capacitors, etc.), wrap ends of wires securely about the terminals before soldering.

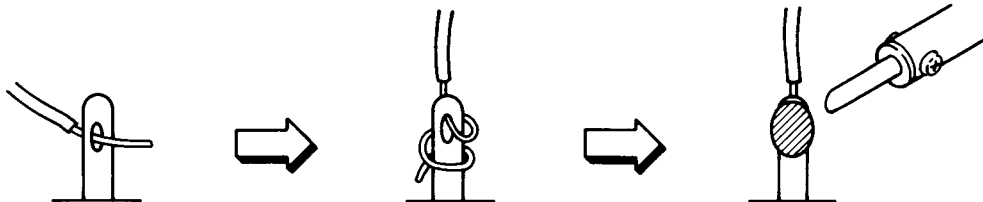

6. Observe that wires do not contact heat producing parts (heatsinks, oxide metal film resistors, fusible resistors, etc.).
7. Check that replaced wires do not contact sharp edged or pointed parts.
8. Also check areas surrounding repaired locations.
9. Use care that foreign objects (screws, solder droplets, etc.) do not remain inside the set.

VOLTAGE CONVERSION

Models for Canada, Europe, USA, UK and Australia are not equipped with this facility.

Each machine is preset at the factory according to destination, but some machines can be set to 110V, 120V, 220V or 240V as required.

If voltage change is necessary, this can be accomplished as follows:

1. Disconnect power cord.
2. Loosen holding screws and remove upper cover.
3. Remove short pin plug from present holes and replace in correct holes. Follow the markings explicitly.

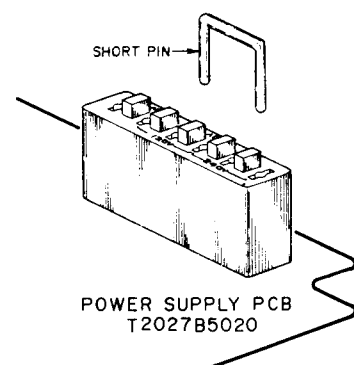

CYCLE CONVERSION

With DC motor, cycle conversion is not necessary.

SECTION 1

SERVICE MANUAL

TABLE CONTENTS

I. SPECIFICATIONS	4
II. DISMANTLING OF UNIT	5
III. CONTROLS	6
IV. PRINCIPAL PARTS LOCATION	7
V. MECHANICAL AND HEAD ADJUSTMENT	8
VI. AMPLIFIER ADJUSTMENT	9
VII. DC RESISTANCE OF VARIOUS COILS	12
VIII. CLASSIFICATION OF VARIOUS P.C BOARDS	12
1. P.C BOARD TITLES AND IDENTIFICATION NUMBER	12
2. COMPOSITION OF VARIOUS P.C BOARDS	13

For basic adjustments, measuring methods, and operating principles, refer to GENERAL TECHNICAL MANUAL.

I. SPECIFICATIONS

HEADS	Erase Head × 1 High Density Head for REC/P.B × 1
MOTOR	Electronically speed controlled DC motor for capstan drive × 1
WOW & FLUTTER	0.12% (DIN) 0.05% (WRMS)
FREQUENCY RESPONSE	Normal: 20 to 15,000 Hz ±3 dB CrO ₂ : 20 to 16,000 Hz ±3 dB Metal: 20 to 17,000 Hz ±3 dB
S/N	56 dB (measured via tape with peak recording level) Dolby B-type NR switch ON: Improves up to 5 dB at 1 kHz, 10 dB above 5 kHz. Dolby C-type NR switch ON: Improves up to 15 dB at 500 Hz, 20 dB at 1 kHz to 10 kHz.
DISTORTION	0.7% (Metal Tape)
INPUT	Line: 70 mV/47 kohms MIC: 0.25 mV/5 kohms
OUTPUT	Line: 410 mV/1 kohms Phones: 0.3 mW/8 ohms
POWER CONSUMPTION	14W (U), 15W (C), 16W (A)
POWER REQUIREMENTS	120V, 60 Hz for USA and Canada 220V, 50 Hz for Europe except UK 240V, 50 Hz for UK and Australia 110V/120V/220V/240V, 50/60 Hz internally switchable for other countries
FIMENSIONS	440 (W) × 103 (H) × 233 (D) mm (17.3 × 4.1 × 9.2 inches)
WEIGHT	4.0 kg (8.8 lbs)

* For improvement purposes, specifications and design are subject to change without notice.

* Noise reduction manufactured under license from Dolby Laboratories Licensing Corporation. "Dolby" and the Double-D symbol are are trade marks of Dolby Laboratories Licensing Corporation.

II. DISMANTLING OF UNIT

In case of trouble, etc. necessitating dismantling, please dismantle in the order shown in the photographs. Reassemble in reverse order.

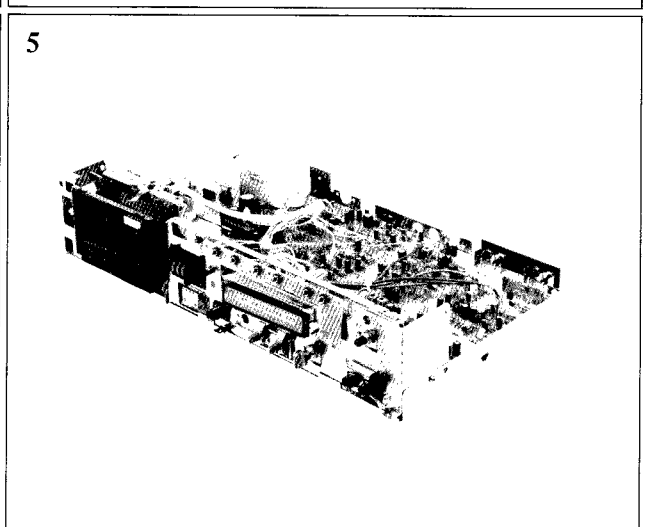
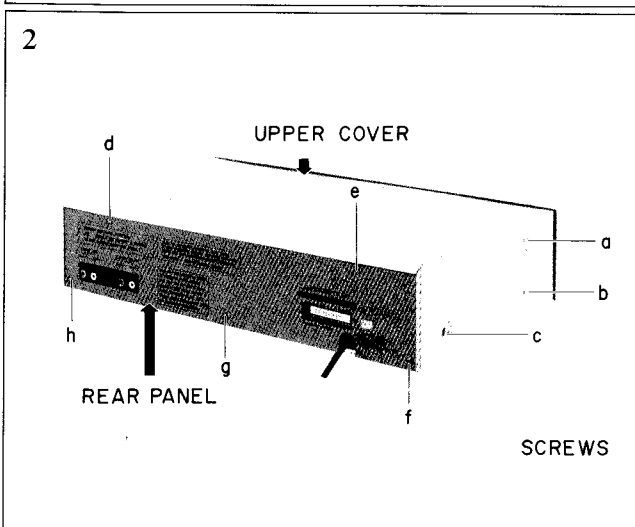
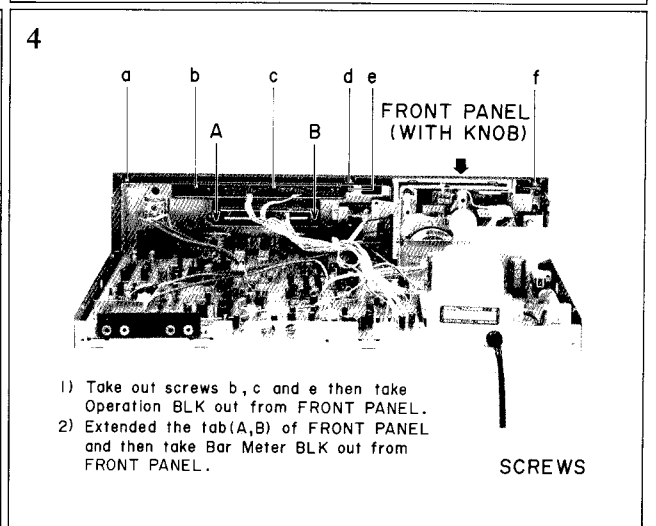
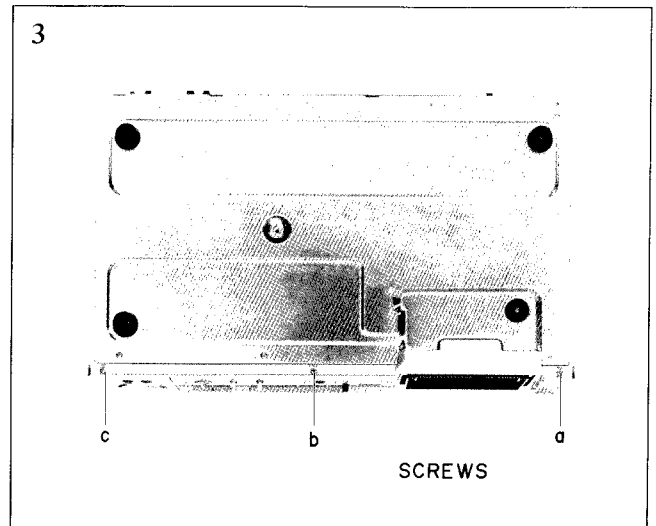
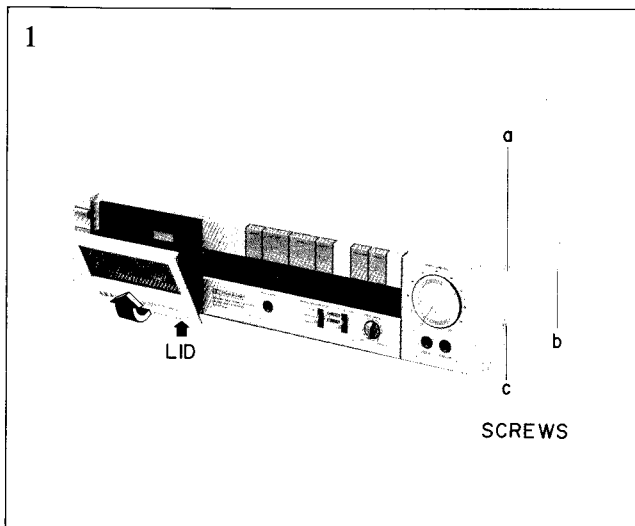

III. CONTROLS

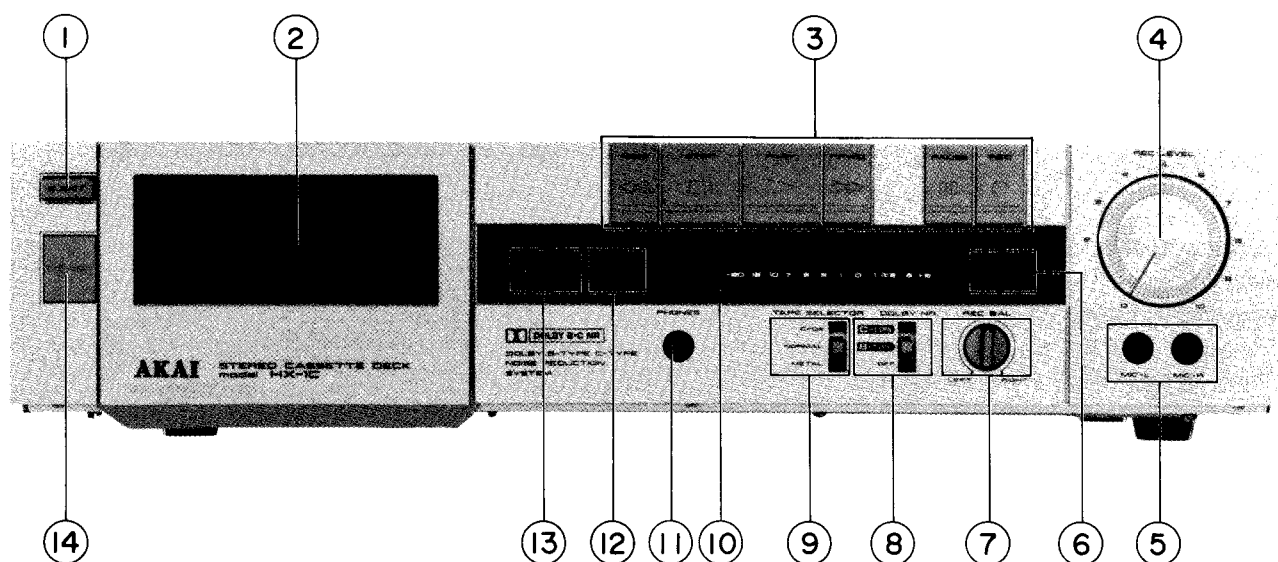

Fig. 3-1 Front View



Fig. 3-2 Rear View

- | | |
|------------------------|--------------------|
| 1. EJECT BUTTON | 10. VU METER |
| 2. CASSETTE HOLDER | 11. PHONES JACK |
| 3. OPERATION BUTTONS | 12. RESET BUTTON |
| 4. REC LEVEL CONTROL | 13. TAPE COUNTER |
| 5. MIC JACKS (L/R) | 14. POWER SWITCH |
| 6. REC INDICATOR | 15. LINE IN JACKS |
| 7. REC BALANCE CONTROL | 16. LINE OUT JACKS |
| 8. DOLBY NR SELECTOR | 17. AC POWER CORD |
| 9. TAPE SELECTOR | |

IV. PRINCIPAL PARTS LOCATION

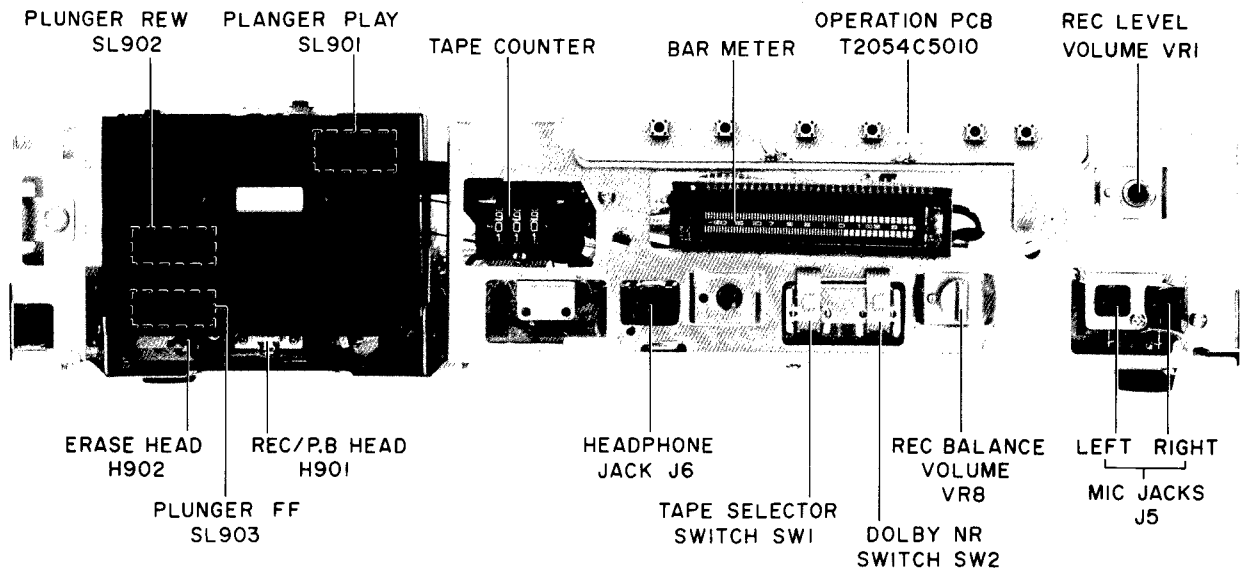

Fig. 4-1 Front View

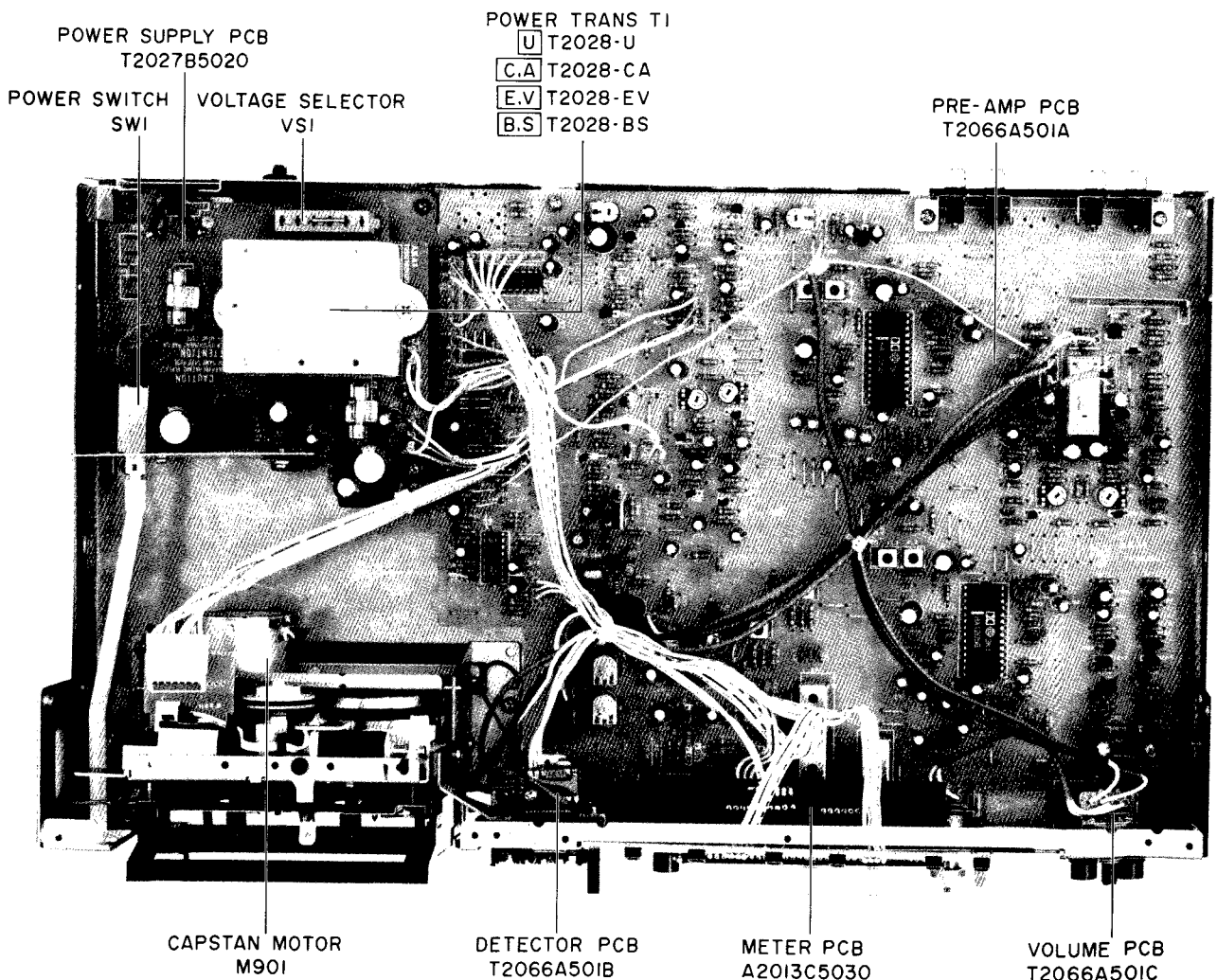

Fig. 4-2 Top View

V. MECHANICAL AND HEAD ADJUSTMENT

1. VARIOUS TORQUE MEASUREMENT

Use the Cassette Torque Meter (AT-751179) to confirm that the value of each mode is as follows:

- Take up Torque : 35 to 70 g-cm
- FF/REW Torque : 70 to 150 g-cm

2. TAPE SPEED ADJUSTMENT

(Refer to Fig. 5-1)

Playback a 1,000 Hz pre-recorded test tape (AT-750774) or a 3,150 Hz pre-recorded test tape (AT-751263) and adjust the tape speed adjustment volume to obtain a tape speed of 1,000 Hz \pm 3 Hz or 3,150 Hz \pm 10 Hz.

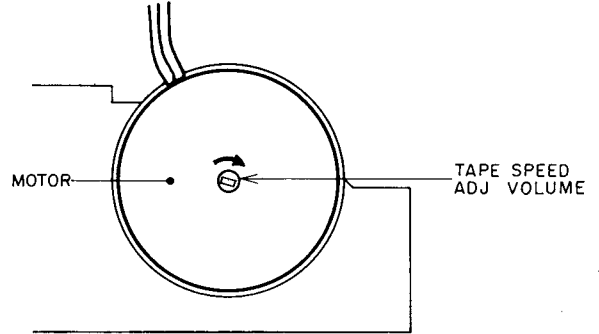

Fig. 5-1 Tape Speed Adjustment

3. RECORDING/PLAYBACK HEAD AZIMUTH ALIGNMENT (Refer to Fig. 5-2)

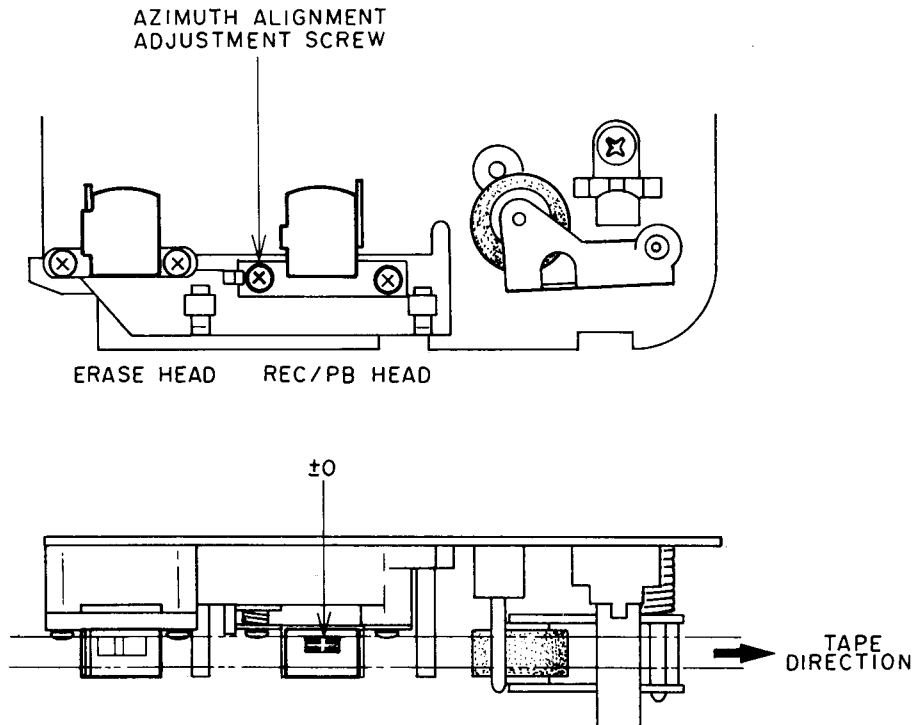

Fig. 5-2 Head Adjustment

- a) Playback a 10 kHz pre-recorded cassette azimuth alignment test tape (AT-750778) and adjust screw shown in Fig. 5-2 to obtain maximum output on both channels.
- b) Invert cassette and confirm that the output level does not change from that obtained in Item 3-a) above.
If the output level differs, adjust in the same way as in Item 3-a) above until both sides of the test tape display equal output.

- NOTES:**
1. Be sure to clean the heads prior to head adjustment.
 2. Be careful not to use a magnetized driver or other magnetized tools in the vicinity of the heads.
 3. Be sure to demagnetize the heads with a Head Demagnetizer before and after head adjustment.

VI. AMPLIFIER ADJUSTMENT

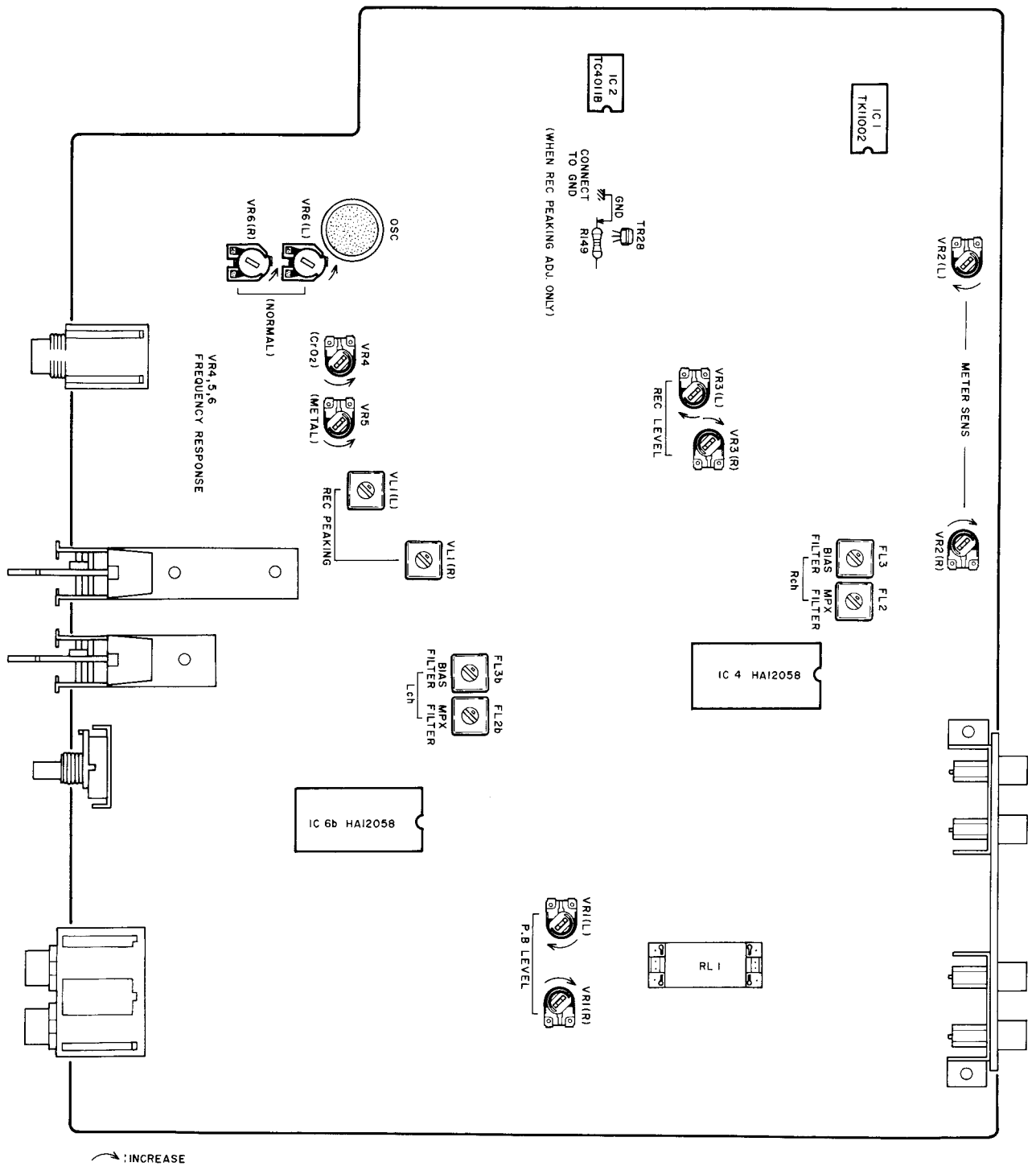

Fig. 6-1 Pre-Amplifier Adjustment Points

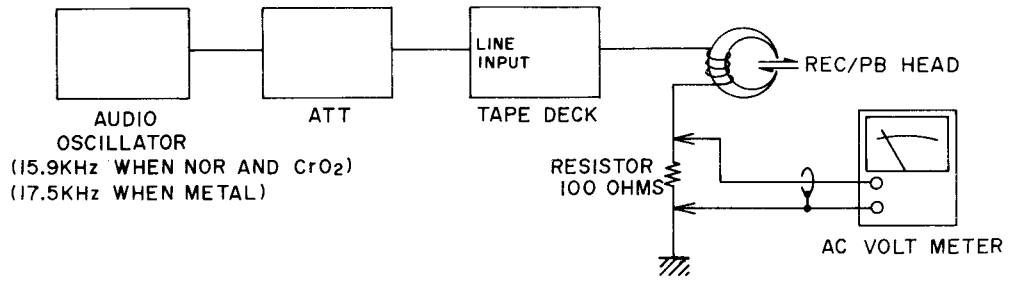

Fig. 6-2 Instruments Connection

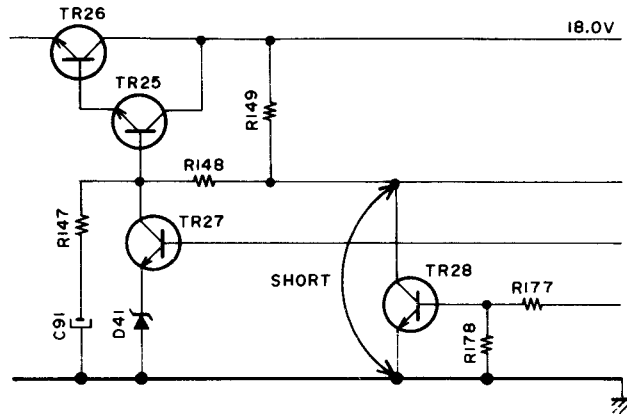

Fig. 6-3 How to Stop REC Bias Oscillation

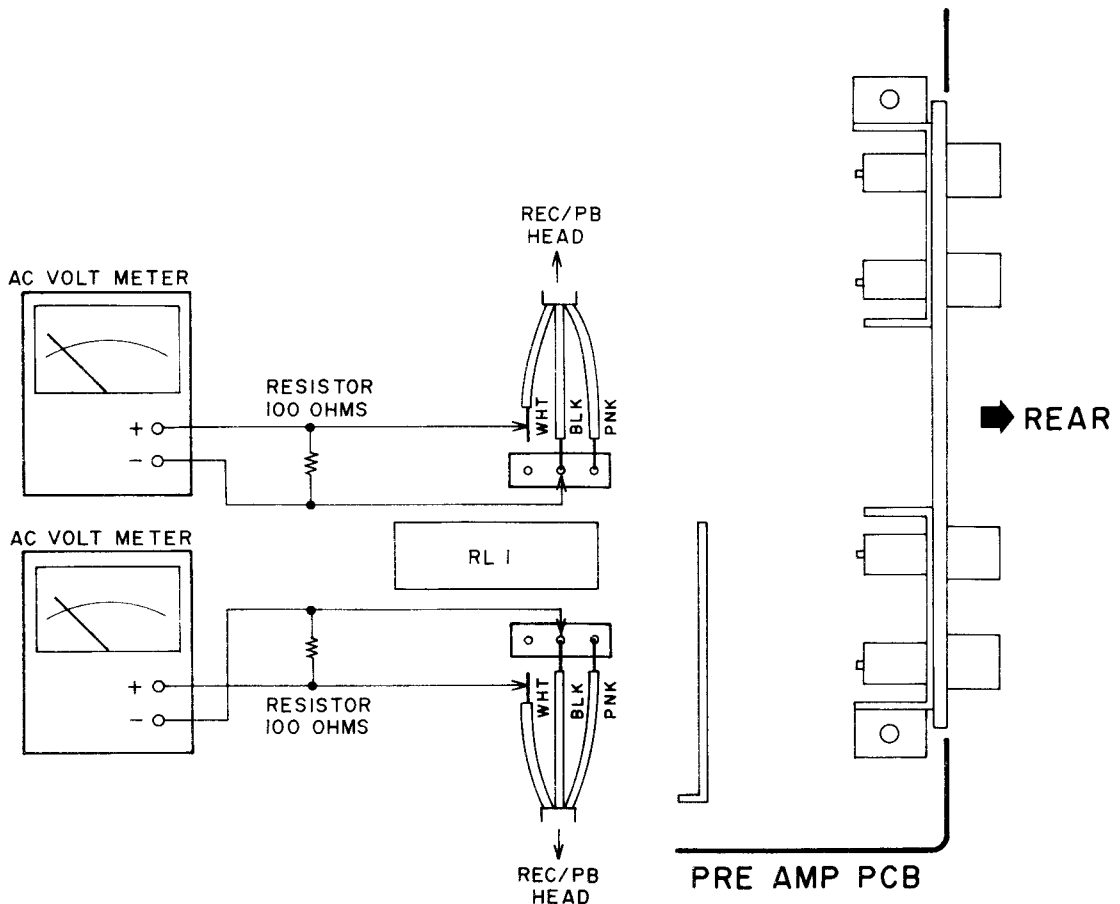

Fig. 6-4 REC Peaking Adjustment

Step	Adjustment Item	Test Tape Supply Signal	Mode	Adjustment Parts	Result	Remarks
1	P.B Level	315 Hz or 333 Hz	P.B	VR1	-5.5 ± 0.2 dBm or -6.1 ± 0.2 dBm	Set Tape Selector Switch to NORMAL.
2	REC Peaking	NORMAL and CrO ₂ 15.9 kHz METAL 17.5 kHz from oscillator	REC	VL1	Maximum AC Voltmeter indication	Refer to NOTE 3, 4 and Figs. 6-1, 6-4.
3	Normal Position Frequency Response	Normal Blank Tape 1 kHz, 10 kHz -25.5 dBm	REC/P.B	VR6	1 kHz to 10 kHz ± 0.3 dBm	
4	CrO ₂ Position Frequency Response	CrO ₂ Blank Tape 1 kHz, 10 kHz -25.5 dBm	REC/P.B	VR4	1 kHz to 10 kHz ± 0.5 dBm	Set Tape Selector Switch to CrO ₂ .
5	Metal Position Frequency Response	Metal Blank Tape 1 kHz, 10 kHz -25.5 dBm	REC/P.B	VR5	1 kHz to 10 kHz ± 0.5 dBm	Set Tape Selector Switch to Metal.
6	REC Level	Normal Blank Tape 1 kHz, -5.5 dBm	REC/P.B	VR3	-5.5 ± 0.3 dBm	Set Tape Selector Switch to Normal.
7	MPX Filter	19 kHz from oscillator	REC	FL2	Minimum Output See NOTE 6.	Set DOLBY-NR Switch to B type or C type
8	Bias Filter	No signal Input	REC	FL3	Minimum Output See NOTE 7	Set Tape Selector Switch to METAL. Set REC Volume to maximum.
9	Meter Sensitivity	1 kHz input	REC PAUSE	VR2	+1 VU extinguishes at Line output -5.2 dBm	

- NOTES:**
1. Except for Step 7 set Dolby NR switch to OFF Position.
 2. Use the following cassette measuring tapes:
 NORMAL Tape : Maxell UD C-60
 CrO₂ Tape : TDK SA C-60
 METAL Tape : TDK MA C-60
 3. Stop the recording bias oscillator while making record peaking adjustment.
 4. Unless the core is moved unintentionally this adjustment is not necessary.
 5. As the test tape has been changed set to -6.1 ± 0.2 dBm when using 333 Hz test tape. For details, refer to Service Guide (No. 0012) issued in NOV., 1982.
 6. Confirm line output level is less than -35.5 dBm.
 7. Confirm line output level is less than -45.5 dBm.

VII. DC RESISTANCE OF VARIOUS COILS

Description	DC Resistance
REC/P.B Head	210 ohms \pm 20%
Erase Head	75 ohms \pm 10%

VIII. CLASSIFICATION OF VARIOUS P.C BOARDS

1. P.C BOARD TITLES AND IDENTIFICATION NUMBER

P.C Board Title		P.C Board Number
PRE AMP	P.C BOARD	T2066A501A
DETECTOR	P.C BOARD	T2066A501B
VOLUME	P.C BOARD	T2066A501C
POWER SUPPLY	P.C BOARD	T2027B5020 (2ED) U
POWER SUPPLY	P.C BOARD	T2027B5020 (2ED) C A
POWER SUPPLY	P.C BOARD	T2027B5020 (2ED) E V B S
OPERATION	P.C BOARD	T2054C5010
METER	P.C BOARD	A2013C5030

2. COMPOSITION OF VARIOUS P.C BOARDS

1) PRE AMP P.C BOARD T2066A501A, DETECTOR P.C BOARD T2066A501B and VOLUME P.C BOARD T2066A501C

LOCATION OF COMPONENTS

IC	-----	1E
IC1	-----	1E
IC2,3	-----	2E
IC4	-----	1B
IC4b	-----	3B

TR	-----	1D
TR1,2	-----	1D
TR3	-----	2D
TR4,5,6	-----	1E
TR10,10b	-----	1A
TR11,12,11b,12b	-----	2A
TR13	-----	2B
TR14,15,14b,15b	-----	3A
TR16	-----	1B
TR16b	-----	2B
TR17,17b	-----	3D
TR19,20	-----	1D
TR19b to 21b	-----	1C
TR21,22	-----	2D
TR22b	-----	2C
TR23,24	-----	3D
TR25 to 29	-----	2D
TR30	-----	1A
TR33	-----	1D
TR35,35b	-----	3C
TR36,36b	-----	1A

TERMINAL

J1,2	-----	1E
J3	-----	3E
① to ⑧	-----	1E
⑨ to ⑪	-----	1A
⑫,⑬,⑭	-----	3B
⑮	-----	1C
⑯	-----	2B
⑰ to ⑲	-----	1A
⑳,㉑,㉒	-----	1D
㉓ to ㉕	-----	3D
㉖,㉗	-----	1E
㉘	-----	2D
㉙	-----	1C
㉚	-----	2B

TR1,2	-----	2SB774(Q,R,S,T)
TR3,12,19,20,22,25,27,28,33,36	-----	2SC2603(E,F)
TR4 to 6	-----	2SD1111
TR10,11,14 to 16	-----	2SC132S(G,H)
TR13,23,24	-----	2SC2274K(E,F)
TR17,29	-----	2SA1115(E,F)
TR21	-----	2SD1012-V(F,G)
TR26	-----	2SC1061(C,D)
TR30	-----	2SC2130(G,H)
TR35	-----	2SD1010(R,S,T)

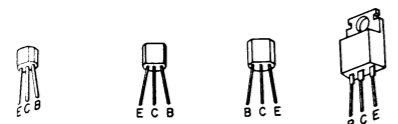

2SA1115	2SB774	2SC132S	2SC1061
2SC2603	2SC2274K	2SC2130	
2SD1012	2SD1010	2SD1111	

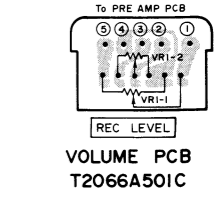
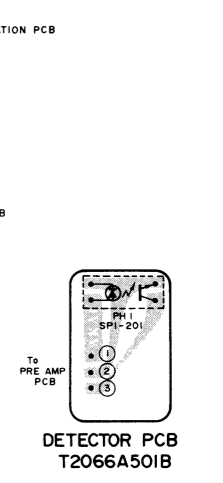
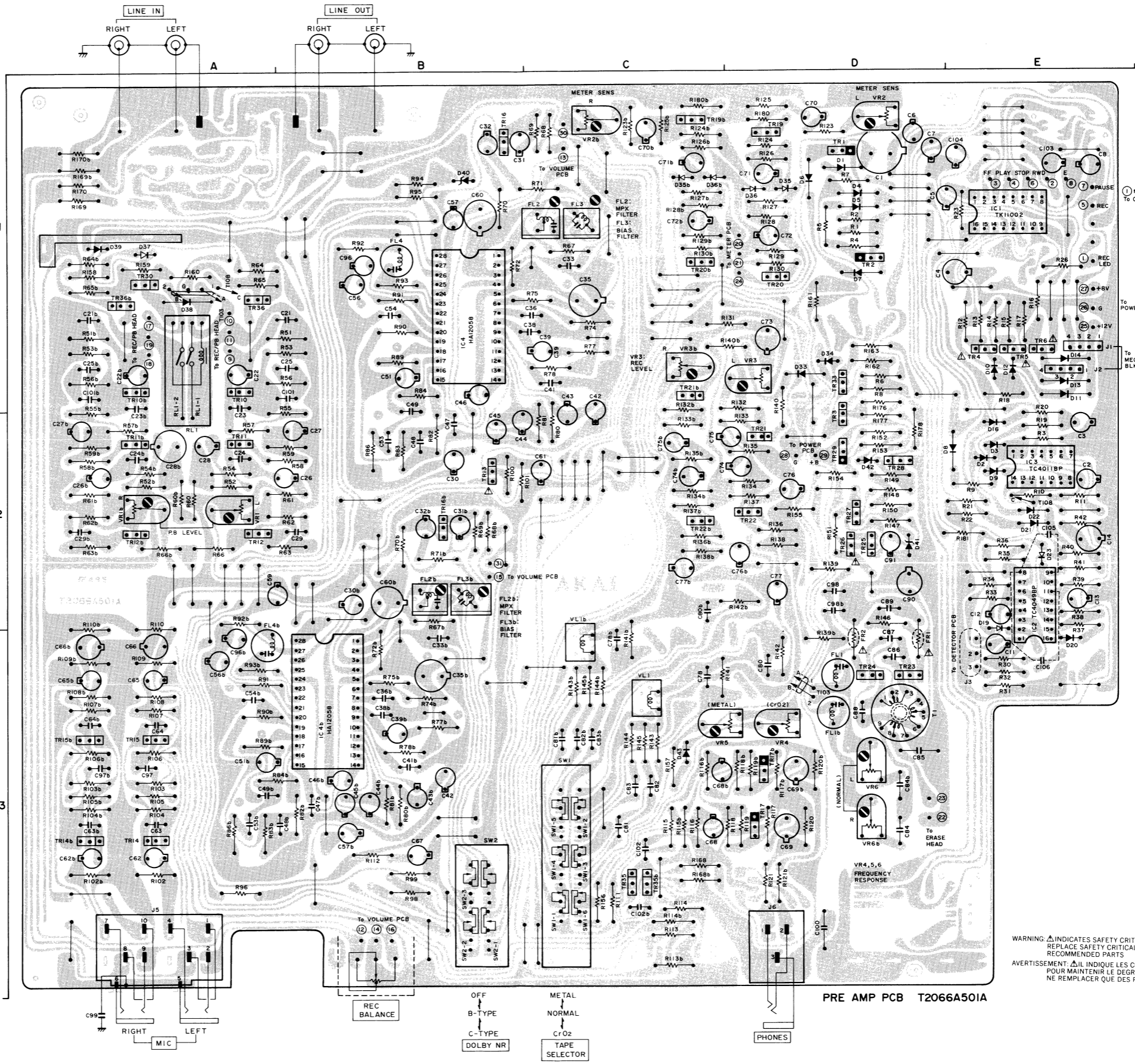

WARNING: ⚠ INDICATES SAFETY CRITICAL COMPONENTS. FOR CONTINUED SAFETY, REPLACE SAFETY CRITICAL COMPONENTS ONLY WITH MANUFACTURER'S RECOMMENDED PARTS.
 AVERTISSEMENT: ⚠ IL INDIQUE LES COMPOSANTS CRITIQUES DE SÉCURITÉ. POUR MAINTENIR LE DEGRÉ DE SÉCURITÉ DE L'APPAREIL, NE REMPLACER QUE DES PIÈCES RECOMMANDÉES PAR LE FABRICANT.

2) POWER SUPPLY P.C BOARD T2027B5020 (2ED) **U**

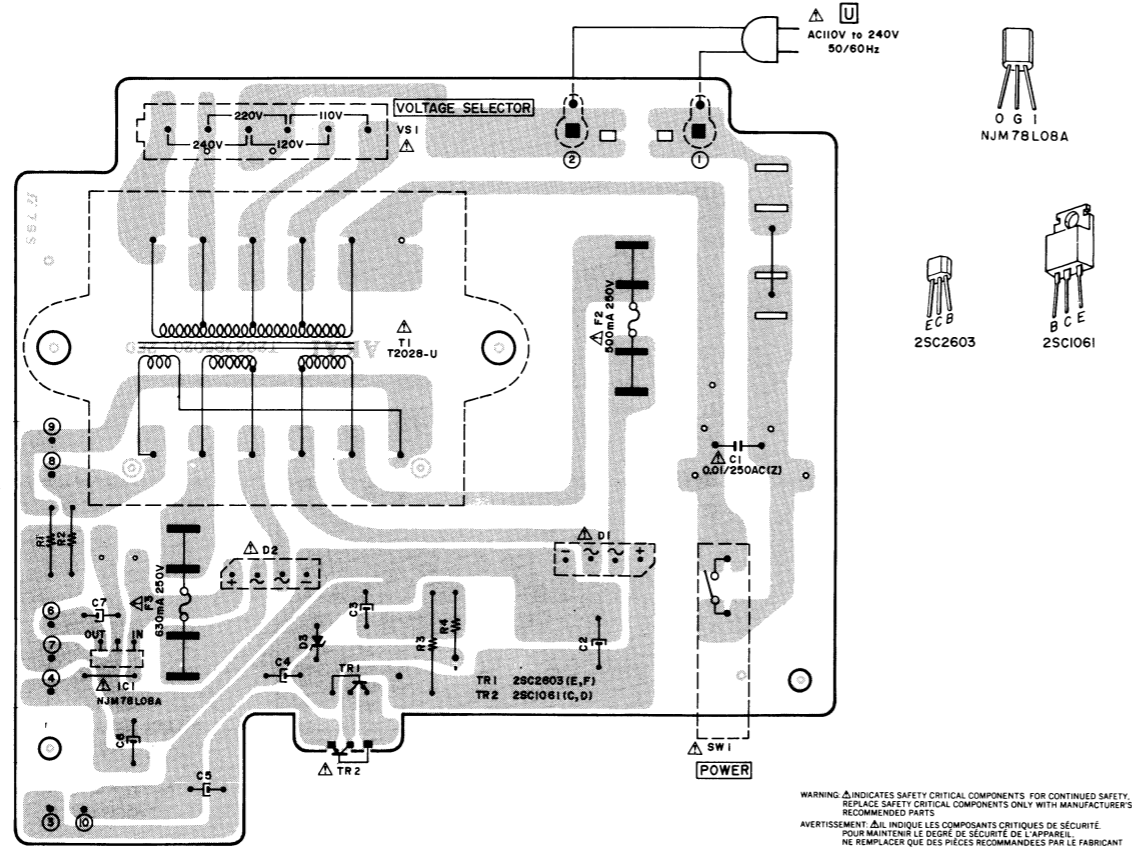

4) POWER SUPPLY P.C BOARD T2027B5020 (2ED) **E V B S**

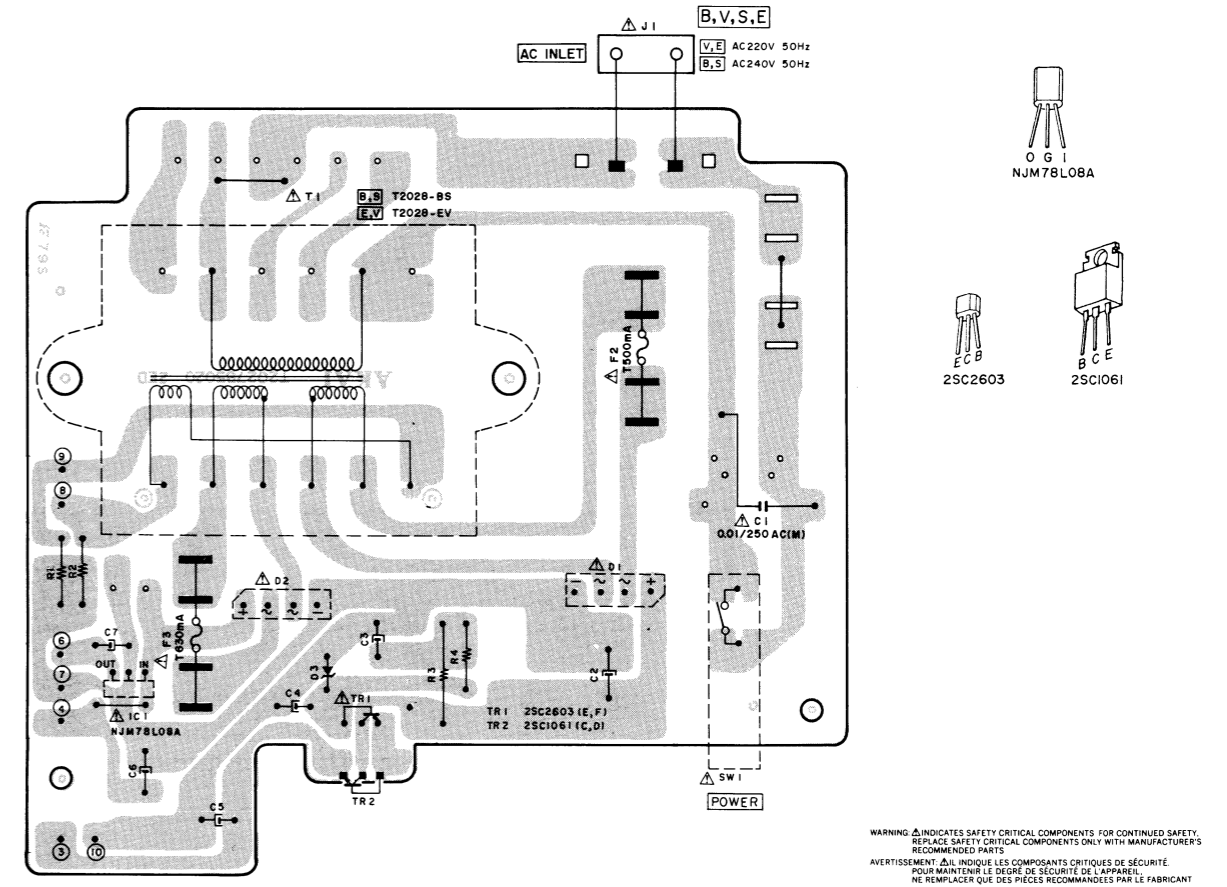

3) POWER SUPPLY P.C BOARD T2027B5020 (2ED) **C A**

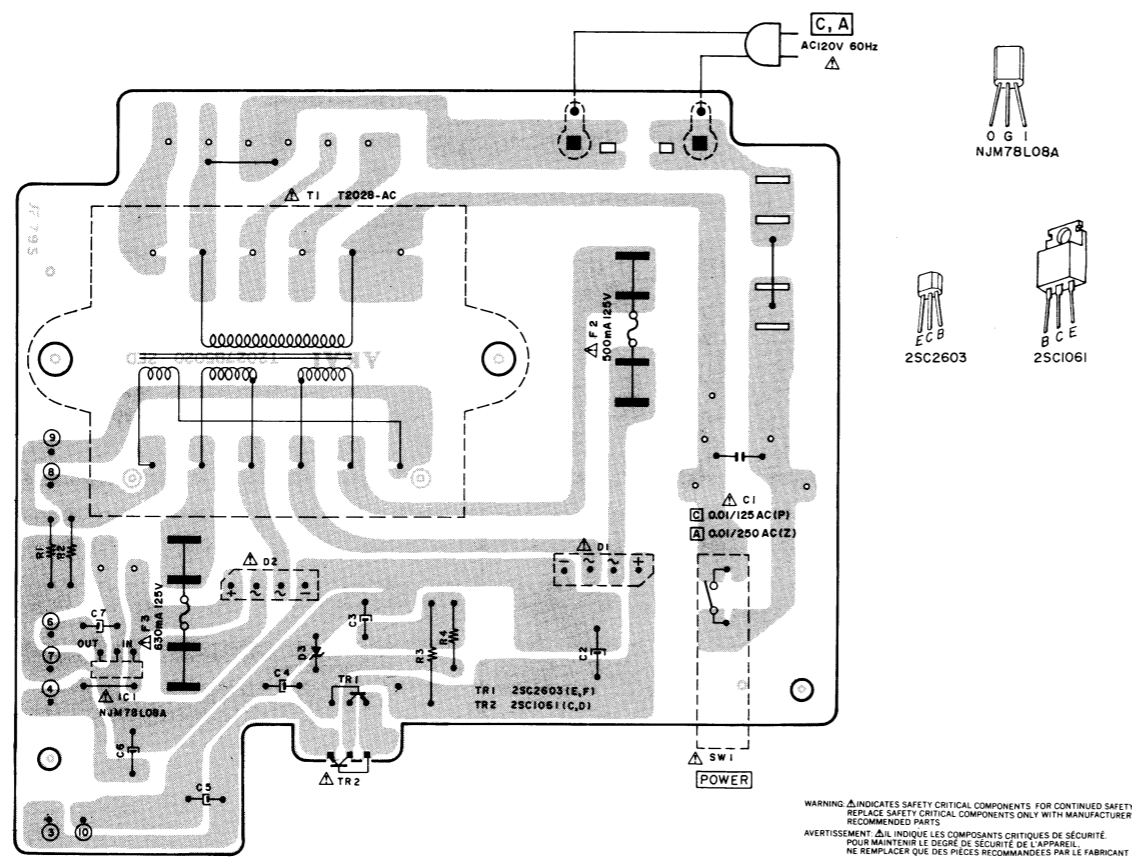

5) OPERATION P.C BOARD T2054C5010

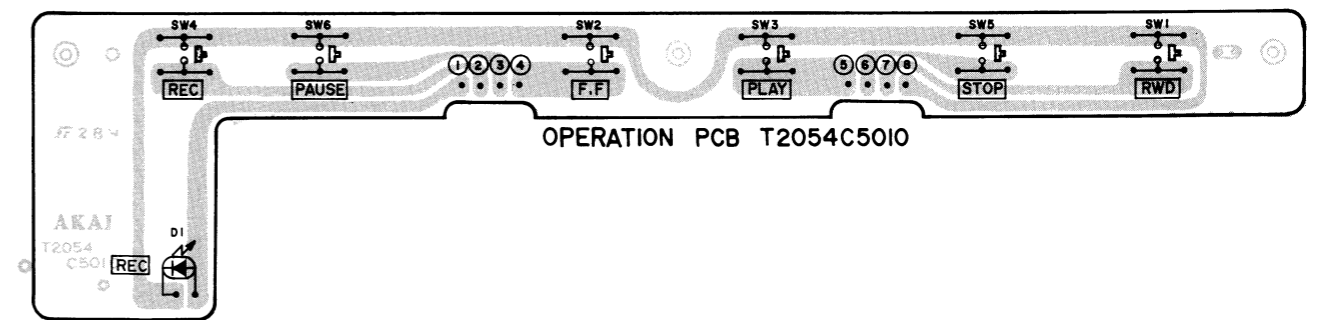

6) METER P.C BOARD A2013C5030

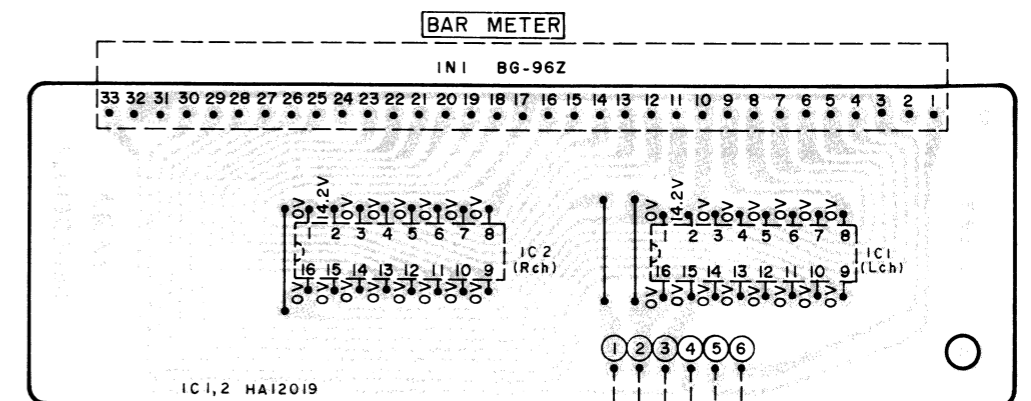

SECTION 2

PARTS LIST

TABLE OF CONTENTS

RECOMMENDED SPARE PARTS	17
1. MECHA BLOCK	18
2. PRE AMP P.C BOARD BLOCK	19
3. OPERATION P.C BOARD BLOCK	19
4. METER P.C BOARD BLOCK	19
5. POWER SUPPLY P.C BOARD BLOCK	19
6. ASSEMBLY BLOCK	20
7. FINAL ASSEMBLY BLOCK	22
INDEX	23

Resistors and Capacitors which are not listed in this parts list, please refer to COMMON LIST FOR SERVICE PARTS.

ATTENTION

1. When placing an order for parts, be sure to list the parts no., model no., and description. There are instances in which if any of this information is omitted, parts cannot be shipped or the wrong parts will be delivered.
2. Please be careful not to make a mistake in the parts no. If the parts no. is in error, a part different from the one ordered may be delivered.
3. Because parts number and parts unit supply in the Preliminary Parts List may be partially changed, please use this parts list for all future reference.

HOW TO USE THIS PARTS LIST

1. This Parts List shows the parts that are considered necessary for repairs. Other parts, such as resistors and capacitors, are shown in the "Common List for Service Parts". Select and order such parts from the "Common List for Service Parts".
2. The Recommended Spare Parts shows those parts in the Parts List which are considered particularly important for service.
3. Parts not shown in the Parts List and "Common List for Service Parts" will not be supplied in principle.
4. How to read list
 - a) Mechanism Block
 - b) P.C Board Block

2. HEAD BASE BLOCK

REF. NO.	PARTS NO.	DESCRIPTION
2-1x	BH-T2023A320A	HEAD BASE BLOCK GX-F66R
2-2	HP-H2206A010A	HEAD R/P PR4-8FU C
2-3	ZS-477876	PAN20x03STL CMT
2-4	ZS-536488	BID20x08STL CMT
2-5	ZG-402895	CS ANGLE ADJUST SPRING

SP (Service Parts) Classification

A small "x" indicates the inability to show that particular part in the Photo or Illustration.

This number corresponds with the individual parts index number in that figure

This number corresponds with the Figure Number

6. SYS. CON. P.C BOARD BLOCK

REF. NO.	PARTS NO.	DESCRIPTION
6-1	BA-T2034A070A	PC SYS CON BLK GX-F44R
6-IC1	EI-324536	IC HD14049BP
6-IC2	EI-336801	IC MB8841-564M
6-IC3	EI-331661	IC SN7405N
6-IC4	EI-336725	IC M54527P
6-TR1to4	ET-200985	TR 2SC2603 F,G
6-TR5to28	ET-554657	TR 2SA733A P,Q
6-D1	ED-318292	D SILICON H 1S2473T-77 T26
6-D2to4	ED-308952	D GERMA V 1K34A-LR F07
6-D5to10	ED-318292	D SILICON H 1S2473T-77 T26
6-X1	EI-318384	OSC X'TAL NC-18C 3.579545MHZ

SP (Service Parts) Classification

This reference numbers corresponds with symbol numbers of Schematic Diagrams.

5. Both the kind of part and installation position can be determined by the Parts Number. To determine where a parts number is listed, utilize Parts Index at end of Parts List. It is necessary first of all to find the Parts Number. This can be accomplished by using the Reference Number listed at right of parts number in the Parts Index.

WARNING

⚠ INDICATES SAFETY CRITICAL COMPONENTS. FOR CONTINUED SAFETY, REPLACE SAFETY CRITICAL COMPONENTS ONLY WITH MANUFACTURER'S RECOMMENDED PARTS.

AVERTISSEMENT

⚠ IL INDIQUE LES COMPOSANTS CRITIQUES DE SURETE. POUR MAINTENIR LE DEGRE DE SECURITE DE L'APPAREIL NE REMPLACER LES COMPOSANTS DONT LE FONCTIONNEMENT EST CRITIQUE POUR LA SECURITE QUE PAR DES PIECES RECOMMANDEES PAR LE FABRICANT.

RECOMMENDED SPARE PARTS

Because, if the parts listed below are on hand, almost any repair can be accomplished, we suggest that you stock these Recommended Spare Parts Items.

NO.	PARTS NO.	DESCRIPTION
71	MB-706393	BELT SUB
72	MC-706413	COUNTER ME390-117
73	MI-711752	CLUTCH ASSY
74	MI-711761	IDLER ASSY

NO.	PARTS NO.	DESCRIPTION
1	BF-7111770	FLYWHEEL ASSY
2	BL-711739	PINCH ROLLER ASSY
3	BM-711773	Δ MOTOR ASSY
4	BR-711730	SUPPLY REEL ASSY
5	BR-711732	TAKE-UP REEL ASSY
6	BT-332230	Δ TRANS POWER T2028 (B,S)
7	BT-332227	Δ TRANS POWER T2028 (C,A)
8	BT-332229	Δ TRANS POWER T2028 (E,V)
9	BT-332228	Δ TRANS POWER T2028 (U)
10	ED-330319	Δ D SILICON DBA10B 100/1.0A
11	ED-308952	D GERMA V 1K34A-LR F07
12	ED-322982	D GERMA V 1S188FM-1-LR F07
13	ED-310584	D LED GL9PR2 RED
14	ED-200469	D SILICON H DS448 FA5 F10
15	ED-200468	D SILICON V DS448-VB6
16	ED-323979	D SILICON W03B F12 100/1.0A
17	ED-337295	D ZENER H HZ3 C3
18	ED-329058	D ZENER H HZ5 C1
19	ED-337779	D ZENER V HZ20S7 1
20	EF-593706	Δ FUSE SEMKO T 250V 0.50A
21	EF-601942	Δ FUSE SEMKO T 250V 0.63A
22	EF-327103	Δ FUSE TSC A 250V 0.50A
23	EF-306124	Δ FUSE TSC A 250V 0.63A
24	EF-309390	Δ FUSE TSC 125V 0.50A
25	EF-305703	Δ FUSE TSC 125V 0.63A
26	EH-336775	FILTER DB D07001K 19KHZ
27	EH-336776	FILTER DB D07003K 100KHZ
28	EI-336759	Δ IC TA78L008AP
29	EI-315799	IC HA12019
30	EI-349196	IC HA12058
31	EI-304657	IC TC4011BP
32	EI-305456	IC TC4049BP
33	EI-332425	IC TK11002
34	EJ-283140	Δ SOCKET SELECTER X-I7238 6P
35	EM-332427	IND FL BG-96Z GRAPH
36	EO-332420	COIL OSC 1 0365-047 100KHZ
37	EO-315758	COIL TUN 1 100S-431 100.00KHZ
38	EO-337044	COIL TUN 1 102AK-005
39	EO-321336	COIL VARI 1 FE002 10MH
40	EP-711751	SOLENOID ASSY
41	EP-711758	SOLENOID ASSY
42	EQ-337067	RELAY LEAD LAB2NS 2NO 18V
43	ER-307565	Δ R FUSE ERD2FC S10 1/4W 6R8J
44	ES-348998	Δ SW PUSH SDL1P 01-1
45	ES-336781	SW LEVER 00430540 2-04-03S
46	ES-321274	SW LEVER 63349 2-06-03S
47	ES-711774	SW TACT
48	ES-336780	SW TACT KHH10902
49	ET-317919	Δ TR 2SC1061 C,D
50	ET-309353	Δ TR 2SC2274K E,F
51	ET-332424	Δ TR 2SD1111 AKAI
52	ET-311977	PHOTO SENSOR SPI-201
53	ET-200558	TR 2SA1115 E,F
54	ET-352334	TR 2SB774 Q,R,S,T
55	ET-603257	TR 2SC1312S G,H
56	ET-308937	TR 2SC2130 G,H
57	ET-200505	TR 2SC2603 E,F
58	ET-344999	TR 2SD1010 R,S,T
59	ET-328437	TR 2SD1012-V F,G
60	EV-315416	R S-FIX H D8 3P 103
61	EV-315414	R S-FIX H D8 3P 203
62	EV-322413	R S-FIX H D8 3P 302
63	EV-322416	R S-FIX H D8 3P 303
64	EV-315413	R S-FIX H D8 3P 503
65	EV-336785	R S-FIX H TM8KV2-1S 3P 0.50W 104
66	EV-337068	VR ROTARY 16P10x11 W204
67	HE-711725	HEAD E
68	HR-711724	HEAD R/P
69	MB-711772	BELT COUNTER
70	MB-711757	BELT MAIN

MECHA BLOCK

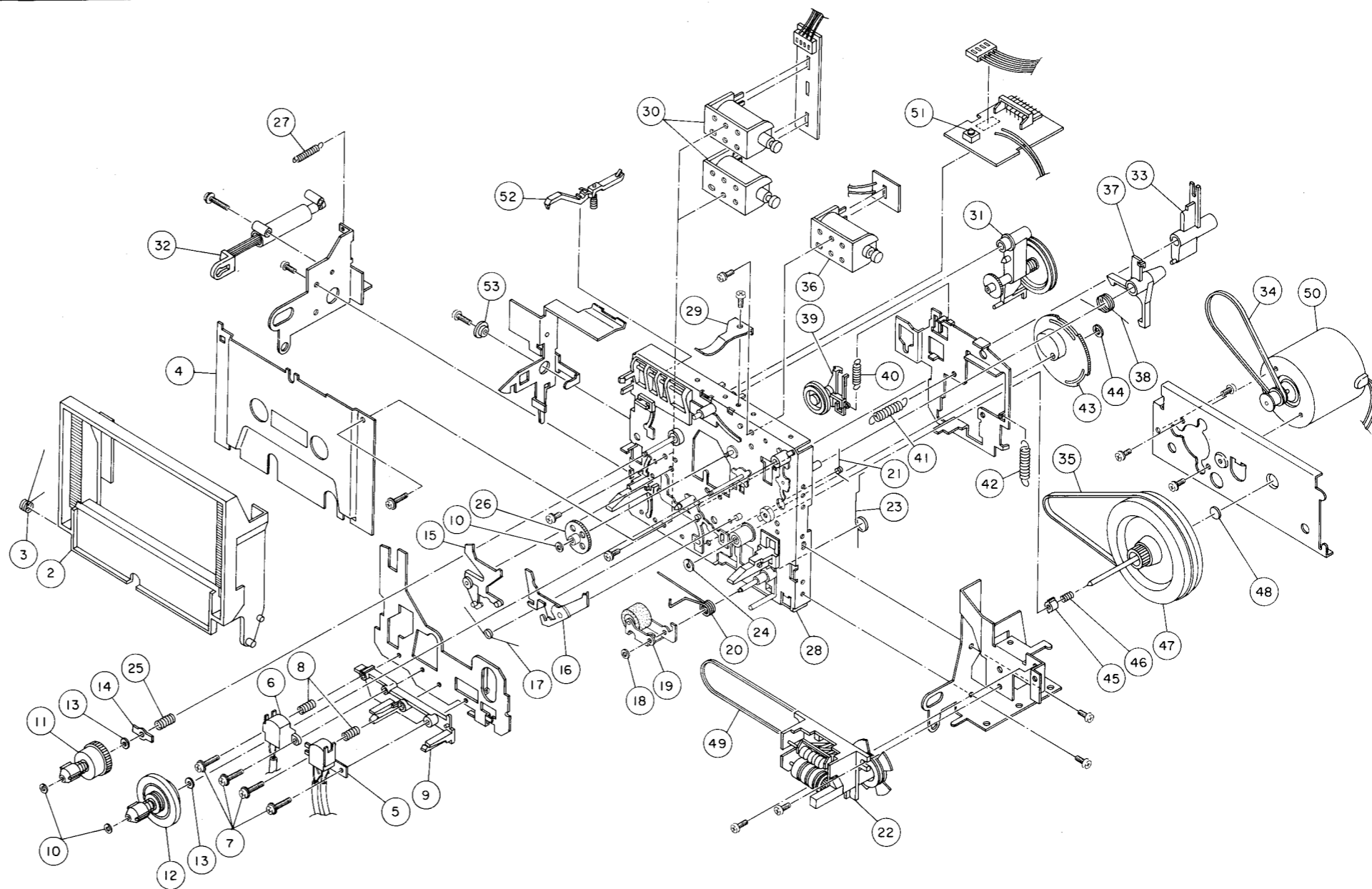

1. MECHA BLOCK

REF. NO.	PARTS NO.	DESCRIPTION	REF. NO.	PARTS NO.	DESCRIPTION	REF. NO.	PARTS NO.	DESCRIPTION
1-1	BB-348278	MECHA BLK FHQ1-022	1-19	BL-711739	PINCH ROLLER ASSY	1-37	ML-711759	ARM PLAY
1-2	TC-706406	SUPPORT CASSETTE ASSY	1-20	ZG-711740	SP PINCH ROLLER	1-38	ZG-711760	SP PLAY ARM
1-3	ZG-706374	SP DOOR	1-21	ZG-711741	SP CHANGE ARM	1-39	MI-711761	IDLER ASSY
1-4	SP-711723	LID DECORATION PLATE	1-22	MC-706413	COUNTER ME390-117	1-40	ZG-711762	SP IDLER
1-5	HR-711724	HEAD R/P	1-23	ZG-711744	SP ASSIST	1-41	ZG-711763	SP HEAD BASE
1-6	HE-711725	HEAD E	1-24	ZW-704947	OIL SEAL	1-42	ZG-711765	SP ASSIST BASE
1-7	ZS-711726	SCREW F LOCK	1-25	ZG-711746	SP BACK TENSION	1-43	MI-711766	GEAR PLAY
1-8	ZG-706378	SP AZIMUTH	1-26	MI-711747	GEAR IDLE	1-44	ZW-711767	WASHER LOCK
1-9	HZ-711728	HEAD SPACER	1-27	ZG-711748	SP EJECT ARM	1-45	ZW-711768	COLLAR CR
1-10	ZW-711729	WASHER FIXATION	1-28	MA-711749	CHASSIS ASSY	1-46	ZG-711769	SP PUSH F/W
1-11	BR-711730	SUPPLY REEL ASSY	1-29	ZG-711750	SP CASSETTE HOLD	1-47	BF-711770	FLYWHEEL ASSY
1-12	BR-711732	TAKE-UP REEL ASSY	1-30	EP-711751	SOLENOID ASSY	1-48	ZW-711771	SPACER
1-13	ZW-711733	PW PSL	1-31	MI-711752	CLUTCH ASSY	1-49	MB-711772	BELT COUNTER
1-14	MT-711734	HOLDER SP	1-32	TC-706398	DAMPER ASSY	1-50	BM-711773	Δ MOTOR ASSY
1-15	ML-711735	ARM BRAKE (L)	1-33	ML-711755	ARM FR CHANGE	1-51	ES-711774	SW TACT
1-16	ML-711736	ARM BRAKE (R)	1-34	MB-706393	BELT SUB	1-52	ML-711776	REC DETECT LEVER ASSY
1-17	ZG-711737	SP TORTION BRAKE	1-35	MB-711757	BELT MAIN	1-53	TC-706389	SPACER
1-18	ZW-711738	WASHER LOCK	1-36	EP-711758	SOLENOID ASSY			

2. PRE AMP P.C BOARD BLOCK

REF. NO.	PARTS NO.	DESCRIPTION
2-1	BA-T2066A060A	PC PRE AMP BLK HX-1C
PRE AMP P.C BOARD		
2-IC1	EI-332425	IC TK1002
2-IC2	EI-305456	IC TC4049BP
2-IC3	EI-304657	IC TC4011BP
2-IC4	EI-349196	IC HA12058
2-TR1,2	ET-352334	TR 2SB774 Q,R,S,T
2-TR3	ET-200505	TR 2SC2603 E,F
2-TR4to6	ET-332424	△ TR 2SD1111 AKAI
2-TR10,11	ET-603257	TR 2SC1312S G,H
2-TR12	ET-200505	TR 2SC2603 E,F
2-TR13	ET-309353	△ TR 2SC2274K E,F
2-TR14to16	ET-603257	TR 2SC1312S G,H
2-TR17	ET-200558	TR 2SA1115 E,F
2-TR19,20	ET-200505	TR 2SC2603 E,F
2-TR21	ET-328437	TR 2SD1012-V F,G
2-TR22	ET-200505	TR 2SC2603 E,F
2-TR23,24	ET-309353	TR 2SC2274K E,F
2-TR25	ET-200505	TR 2SC2603 E,F
2-TR26	ET-317919	△ TR 2SC1061 C,D
2-TR27,28	ET-200505	TR 2SC2603 E,F
2-TR29	ET-200558	TR 2SA1115 E,F
2-TR30	ET-308937	TR 2SC2130 G,H
2-TR33	ET-200505	TR 2SC2603 E,F
2-TR35	ET-344999	TR 2SD1010 R,S,T
2-TR36	ET-200505	TR 2SC2603 E,F
2-D1	ED-200469	D SILICON H DS448 FA5 F10
2-D2,3	ED-200468	D SILICON V DS448-VB6
2-D4to8	ED-200469	D SILICON H DS448 FA5 F10
2-D9,10	ED-200468	D SILICON V DS448-VB6
2-D11	ED-323979	D SILICON W03B F12 100/1.0A
2-D12	ED-200468	D SILICON V DS448-VB6
2-D13,14	ED-323979	D SILICON W03B F12 100/1.0A
2-D16	ED-200468	D SILICON V DS448-VB6
2-D19	ED-322982	D GERMA V 1S188FM-1-LR F07
2-D20to22	ED-200468	D SILICON V DS448-VB6
2-D23	ED-322982	D GERMA V 1S188FM-1-LR F07
2-D33	ED-200469	D SILICON H DS448 FA5 F10
2-D34	ED-200468	D SILICON V DS448-VB6
2-D35,36	ED-322982	D GERMA V 1S188FM-1-LR F07
2-D37	ED-308952	D GERMA V 1K34A-LR F07
2-D38	ED-323979	D SILICON W03B F12 100/1.0A
2-D39	ED-200468	D SILICON V DS448-VB6
2-D40	ED-329058	D ZENER H HZ5 C1
2-D41	ED-337295	D ZENER H HZ3 C3
2-D42,43	ED-200468	D SILICON V DS448-VB6
2-J4	EJ-332435	PIN J P 4P
2-J5	EJ-349149	PHONE J HLJ0523-320 2x3P
2-J6	EJ-349148	PHONE J 3P HLJ0628-024 6.3
2-SW1	ES-321274	SW LEVER 63349 2-06-03S
2-SW2	ES-336781	SW LEVER 00430540 2-04-03S
2-VR1	EV-315413	R S-FIX H D8 3P 503
2-VR2	EV-322416	R S-FIX H D8 3P 303
2-VR3	EV-315414	R S-FIX H D8 3P 203
2-VR4	EV-315416	R S-FIX H D8 3P 103
2-VR5	EV-322413	R S-FIX H D8 3P 302
2-VR6	EV-336785	R S-FIX H TM8KV2-1S 3P 0.50W 104
2-VR8	EV-337068	VR ROTARY 16P10x1I W204
2-VL1	EO-321336	COIL VARI 1 FE002 10MH
2-T1	EO-332420	COIL OSC 1 0365-047 100KHZ
2-FL1	EO-315758	COIL TUN 1 100S-431 100KHZ
2-FL2	EH-336775	FILTER DB D07001K 19KHZ
2-FL3	EH-336776	FILTER DB D07003K 100KHZ
2-FL4	EO-337044	COIL TUN 1 102AK-005
2-FR1,2	ER-307565	△ R FUSE ERD2FC S10 1/4W 6R8J
2-RL1	EQ-337067	RELAY LEAD LAB2NS 2NO 18V
2-C23	EC-306980	C STY V F05 500 221J 50DC
2-C24	EC-201319	C MC V FM 270J 500DC
2-C56	EC-324527	C EC V F05 K R15K 50.0DC
2-C63	EC-306419	C STY V F05 500 681J 50DC
2-C84	EC-325352	C MC V FM 151J 500DC
2-C85	EC-326138	C PP V F10 APH 182J 630DC

REF. NO.	PARTS NO.	DESCRIPTION
2-C87	EC-341675	C PP V APS 223K 100DC
2-C97	EC-427948	C MC V FM 100J 500DC
2-C98	EC-331631	C STY V SNP CQFS 821J 50DC
2-C101	EC-306980	C STY V F05 500 221J 50DC
VOLUME P.C BOARD		
2-VR1C	EV-351956	VR ROTARY 16P20X A104 *L=150
DETECTOR P.C BOARD		
2-PH1	ET-311977	PHOTO SENSOR SPI-201

3. OPERATION P.C BOARD BLOCK

REF. NO.	PARTS NO.	DESCRIPTION
3-SW1to6	ES-336780	SW TACT KHH10902
3-D1	ED-310584	D LED GL9PR2 RED

4. METER P.C BOARD BLOCK

REF. NO.	PARTS NO.	DESCRIPTION
4-IC1	EI-315799	IC HA12019
4-IN1	EM-332427	IND FL BG-96Z GRAPH

5. POWER SUPPLY P.C BOARD BLOCK

REF. NO.	PARTS NO.	DESCRIPTION
5-IC1	EI-336759	△ IC TA78L008AP
5-TR1	ET-200505	TR 2SC2603 E,F
5-TR2	ET-317919	△ TR 2SC1061 C,D
5-D1,2	ED-330319	△ D SILICON DBA10B 100/1.0A
5-D3	ED-337779	D ZENER V HZ20S7 1
5-VS1	EJ-283140	△ SOCKET SELECTOR X-I7238 6P (U ONLY)
5-R3	ER-318430	△ OMF H S15 FS 1W 102J
5-C1U	EC-320548	△ C CE V F 103Z 250AC (U,C,A)
5-C1E	EC-330308	△ C MMY V ECQUF 103M 250AC (E,B,S)
5-C2	EC-316230	C EC V CUT HM 222M 35DC

ASSEMBLY BLOCK

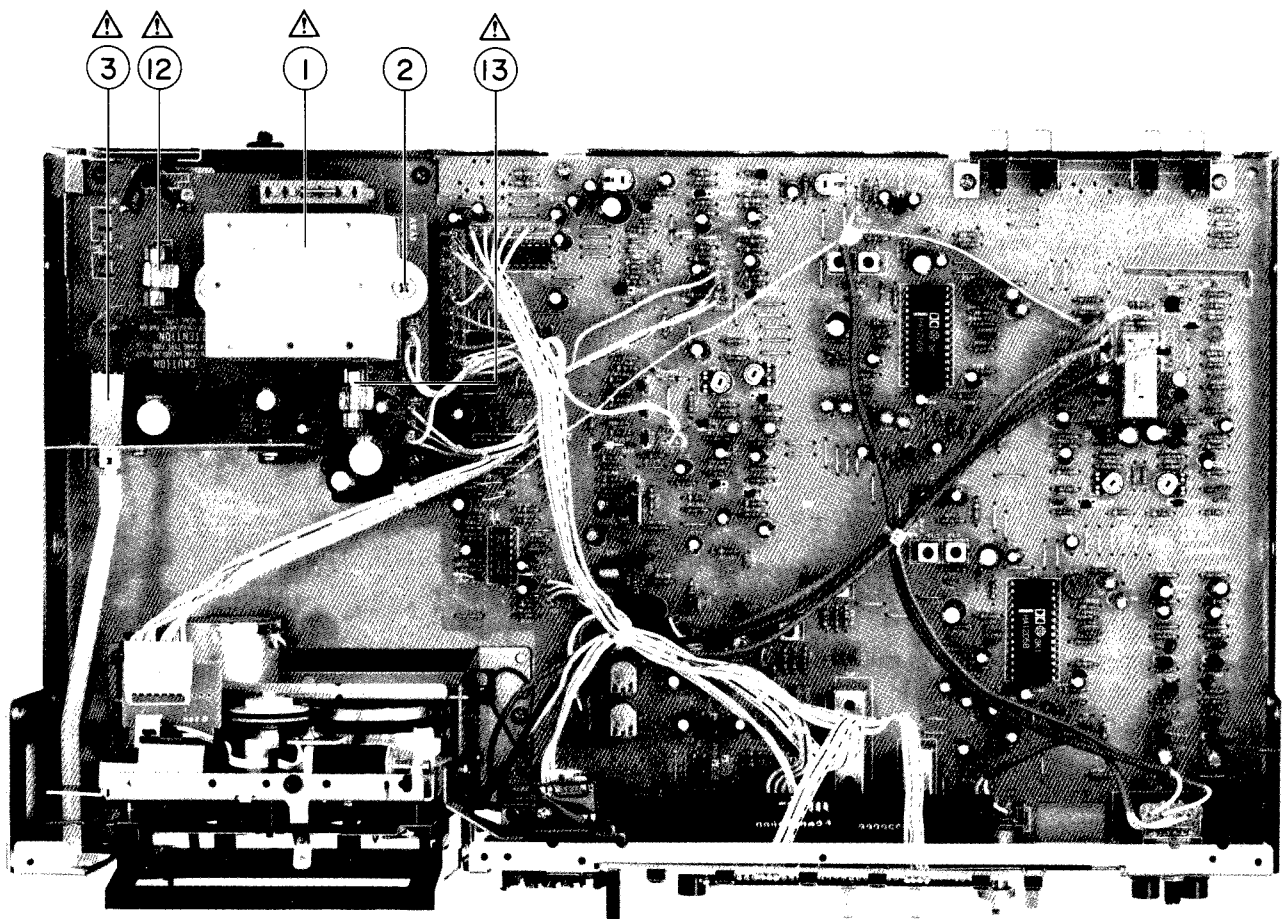
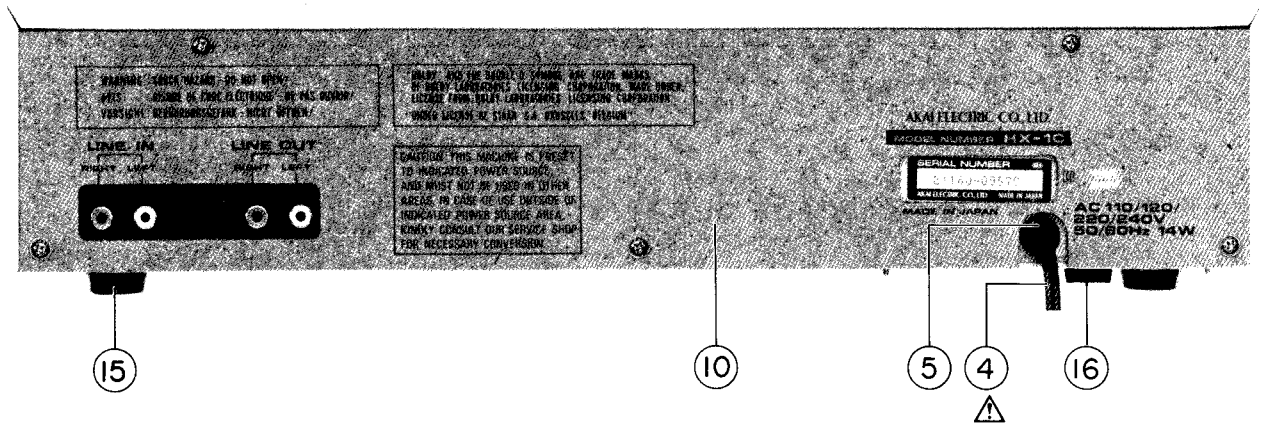

6. ASSEMBLY BLOCK

REF. NO.	PARTS NO.	DESCRIPTION
6-1U	BT-332228	△ TRANS POWER T2028(U) (T1)
6-1C	BT-332227	△ TRANS POWER T2028(C,A)(T1)
6-1E	BT-332229	△ TRANS POWER T2028(E,V)(T1)
6-1B	BT-332230	△ TRANS POWER T2028(B,S)(T1)
6-2	ZS-312116	ST BID40×20STL CMT
6-3U	ES-348998	△ SW PUSH SDL1P 01-1 (SW1)(U,E,B,S)
6-3C	ES-348998	△ SW PUSH SDL1P 01-1(SW1)(C,A)
6-4U	EW-306428	△ AC CORD 2 CORES KP-700A, VFF U/T(U)
6-4C	EW-305691	△ AC CORD 2 CORES KP-8, SPT-1 UC(C,A)
6-5	EZ-631945	STRAIN RELIEF SR-4N-4(U,C,A)
6-6x	EJ-310567	△ SOCKET INLET 0378PC-GS E 2P (J1)(E,B,S)
6-7x	EW-315767	△ AC CORD 2 CORES KP-419C/KS-15 EV(E)
6-8x	EW-322400	△ AC CORD 2 CORES KS-15/GTBS-2F B(B)
6-9x	EW-322401	△ AC CORD 2 CORES KP-560/KS-15 S(S)
6-10U	SP-348360H	PANEL REAR BOARD HX-1C(U)
6-10C	SP-348360J	PANEL REAR BOARD HX-1C(C,A)
6-10E	SP-348360K	PANEL REAR BOARD HX-1C(E,V)
6-10B	SP-348360L	PANEL REAR BOARD HX-1C(B,S)
6-11x	ZW-305013	RV POP32 (A ONLY)
6-12U	EF-327103	△ FUSE TSC A 250V 0.50A(F2)(U)
6-12C	EF-309390	△ FUSE TSC 125V 0.50A(F2)(C,A)
6-12E	EF-593706	△ FUSE SEMKO T 250V 0.50A (F2)(E,B,S)
6-13U	EF-306124	△ FUSE TSC A 250V 0.63A(F3)(U)
6-13C	EF-305703	△ FUSE TSC 125V 0.63A(F3)(C,A)
6-13E	EF-601942	△ FUSE SEMKO T 250V 0.63A (F3)(E,B,S)
6-14x	EW-344151	CORD RR-61A PINX2-PINX2
6-15	SA-202118	FOOT
6-16	SA-349332	FOOT

FINAL ASSEMBLY BLOCK

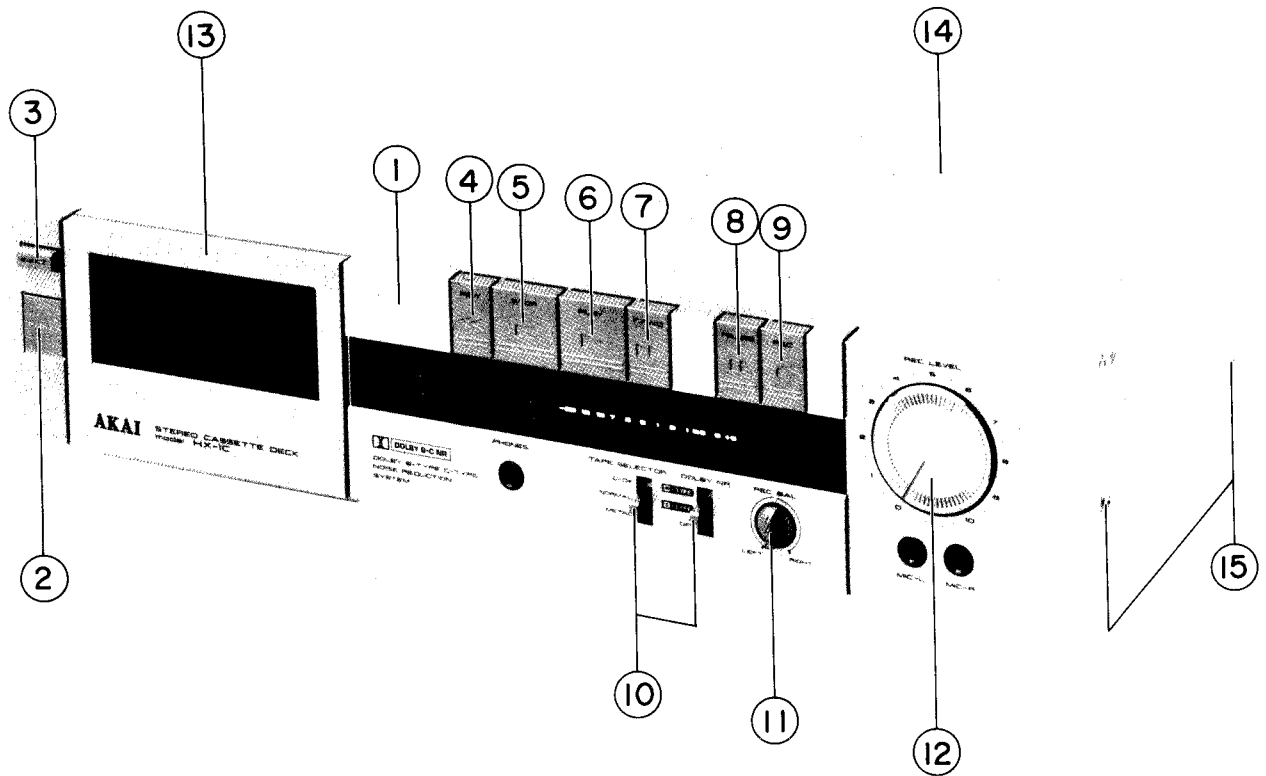

7. FINAL ASSEMBLY BLOCK

REF. NO.	PARTS NO.	DESCRIPTION
7-1	BD-T2066A030A	PANEL FRONT BLK HX-1C
7-1S	BD-T2066A030B	PANEL FRONT BLK HX-1C-S
7-2	SK-343017C	KNOB POWER (2)
7-3	SK-345376A	KNOB EJECT
7-4	SK-345377A	KNOB REW
7-5	SK-345377C	KNOB STOP
7-6	SK-345377E	KNOB PLAY
7-7	SK-345377G	KNOB FF
7-8	SK-345377J	KNOB PAUSE
7-9	SK-345377L	KNOB REC
7-10	SK-332590D	KNOB SWITCH (A-4)
7-10S	SK-332590B	KNOB SW (A-2)
7-11	SK-332591E	KNOB VOLUME (A-5)
7-11S	SK-332591D	KNOB VR (A-4)
7-12	SK-345375A	KNOB VOLUME
7-13	BD-B345373C	LID PANEL(C) PART
7-13S	BD-B345373D	LID PANEL(C)-S PART
7-14	SP-336654C	UPPER COVER (C)
7-15	ZS-341959	ST BID40x06STL NI3

SYMBOL FOR COLOR VARIATION

NONE – STANDARD
S – SILVER

INDEX

PARTS NO.	REF. NO.	PARTS NO.	REF. NO.	PARTS NO.	REF. NO.	PARTS NO.	REF. No.
BA-T2066A060A	2-1	EJ-349148	2-J6	MI-711752	1-31		
BB-348278	1-1	EJ-349149	2-J5	MI-711761	1-39		
BD-B345373C	7-13	EM-332427	4-IN1	MI-711766	1-43		
BD-B345373D	7-13S	EO-315758	2-FL1	ML-711735	1-15		
BD-T2066A030A	7-1	EO-321336	2-VL1	ML-711736	1-16		
BD-T2066A030B	7-1S	EO-332420	2-T1	ML-711755	1-33		
BF-711770	1-47	EO-337044	2-FL4	ML-711759	1-37		
BL-711739	1-19	EP-711751	1-30	ML-711776	1-52		
BM-711773	1-50	EP-711758	1-36	MT-711734	1-14		
BR-711730	1-11	EQ-337067	2-RL1	SA-202118	6-15		
BR-711732	1-12	ER-307565	2-FR1	SA-349332	6-16		
BT-332227	6-1C	ER-307565	2-FR2	SK-332590B	7-10S		
BT-332228	6-1U	ER-318430	5-R3	SK-332590D	7-10		
BT-332229	6-1E	ES-321274	2-SW1	SK-332591D	7-11S		
BT-332230	6-1B	ES-336780	3-SW2	SK-332591E	7-11		
EC-201319	2-C24	ES-336780	3-SW3	SK-343017C	7-2		
EC-306419	2-C63	ES-336780	3-SW4	SK-345375A	7-12		
EC-306980	2-C23	ES-336780	3-SW6	SK-345376A	7-3		
EC-306980	2-C101	ES-336780	3-SW1	SK-345377A	7-4		
EC-316230	5-C2	ES-336780	3-SW5	SK-345377C	7-5		
EC-320548	5-C1U	ES-336781	2-SW2	SK-345377E	7-6		
EC-324527	2-C56	ES-348998	6-3U	SK-345377G	7-7		
EC-325352	2-C84	ES-348998	6-3C	SK-345377J	7-8		
EC-326138	2-C85	ES-711774	1-51	SK-345377L	7-9		
EC-330308	5-C1E	ET-200505	2-TR12	SP-336654C	7-14		
EC-331631	2-C98	ET-200505	2-TR19	SP-348360H	6-10U		
EC-341675	2-C87	ET-200505	2-TR20	SP-348360J	6-10C		
EC-427948	2-C97	ET-200505	2-TR22	SP-348360K	6-10E		
ED-200468	2-D2	ET-200505	2-TR25	SP-348360L	6-10B		
ED-200468	2-D3	ET-200505	2-TR27	SP-711723	1-4		
ED-200468	2-D10	ET-200505	2-TR28	TC-706389	1-53		
ED-200468	2-D12	ET-200505	2-TR33	TC-706398	1-32		
ED-200468	2-D9	ET-200505	2-TR36	TC-706406	1-2		
ED-200468	2-D16	ET-200505	2-TR3	ZG-706374	1-3		
ED-200468	2-D21	ET-200505	5-TR1	ZG-706378	1-8		
ED-200468	2-D20	ET-200558	2-TR17	ZG-711737	1-17		
ED-200468	2-D22	ET-200558	2-TR29	ZG-711740	1-20		
ED-200468	2-D34	ET-308937	2-TR30	ZG-711741	1-21		
ED-200468	2-D39	ET-309353	2-TR13	ZG-711744	1-23		
ED-200468	2-D42	ET-309353	2-TR23	ZG-711746	1-25		
ED-200468	2-D43	ET-309353	2-TR24	ZG-711748	1-27		
ED-200469	2-D1	ET-311977	2-PH1	ZG-711750	1-29		
ED-200469	2-D4	ET-317919	2-TR26	ZG-711760	1-38		
ED-200469	2-D5	ET-317919	5-TR2	ZG-711762	1-40		
ED-200469	2-D6	ET-328437	2-TR21	ZG-711763	1-41		
ED-200469	2-D7	ET-332424	2-TR6	ZG-711765	1-42		
ED-200469	2-D8	ET-332424	2-TR4	ZG-711769	1-46		
ED-200469	2-D33	ET-332424	2-TR5	ZS-312116	6-2		
ED-308952	2-D37	ET-344999	2-TR35	ZS-341959	7-15		
ED-310584	3-D1	ET-352334	2-TR1	ZS-711726	1-7		
ED-322982	2-D19	ET-352334	2-TR2	ZW-305013	6-11x		
ED-322982	2-D23	ET-603257	2-TR10	ZW-704947	1-24		
ED-322982	2-D35	ET-603257	2-TR11	ZW-711729	1-10		
ED-322982	2-D36	ET-603257	2-TR14	ZW-711733	1-13		
ED-323979	2-D11	ET-603257	2-TR15	ZW-711738	1-18		
ED-323979	2-D14	ET-603257	2-TR16	ZW-711767	1-44		
ED-323979	2-D13	EV-315413	2-VR1	ZW-711768	1-45		
ED-323979	2-D38	EV-315414	2-VR3	ZW-711771	1-48		
ED-329058	2-D40	EV-315416	2-VR4				
ED-330319	5-D2	EV-322413	2-VR5				
ED-330319	5-D1	EV-322416	2-VR2				
ED-337295	2-D41	EV-336785	2-VR6				
ED-337779	5-D3	EV-337068	2-VR8				
EF-305703	6-13C	EV-351956	2-VR1C				
EF-306124	6-13U	EW-305691	6-4C				
EF-309390	6-12C	EW-306428	6-4U				
EF-327103	6-12U	EW-315767	6-7x				
EF-593706	6-12E	EW-322400	6-8x				
EF-601942	6-13E	EW-322401	6-9x				
EH-336775	2-FL2	EW-344151	6-14x				
EH-336776	2-FL3	EZ-631945	6-5				
EI-304657	2-IC3	HE-711725	1-6				
EI-305456	2-IC2	HR-711724	1-5				
EI-315799	4-IC1	HZ-711728	1-9				
EI-332425	2-IC1	MA-711749	1-28				
EI-336759	5-IC1	MB-706393	1-34				
EI-349196	2-IC4	MB-711757	1-35				
EJ-283140	5-VS1	MB-711772	1-49				
EJ-310567	6-6x	MC-706413	1-22				
EJ-332435	2-J4	MI-711747	1-26				

AKAI

MODEL HX-1C

SECTION 3

SCHEMATIC DIAGRAM

TABLE OF CONTENTS

1. BLOCK DIAGRAM	27
2. SCHEMATIC DIAGRAM	28

HX-1C

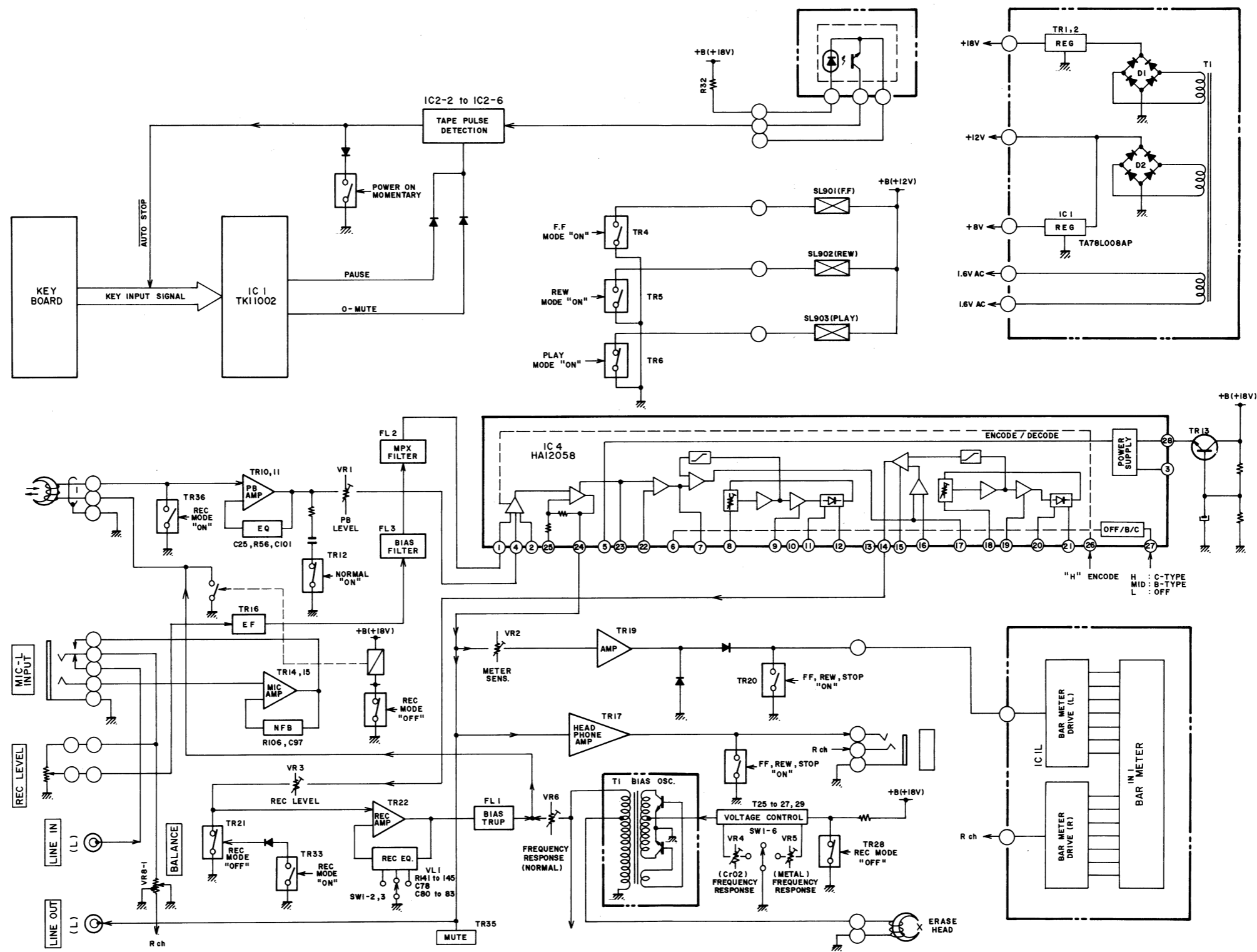

HX-1C
SCHEMATIC DIAGRAM
NO. 2-1 840110A

HX-1C

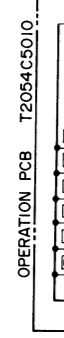
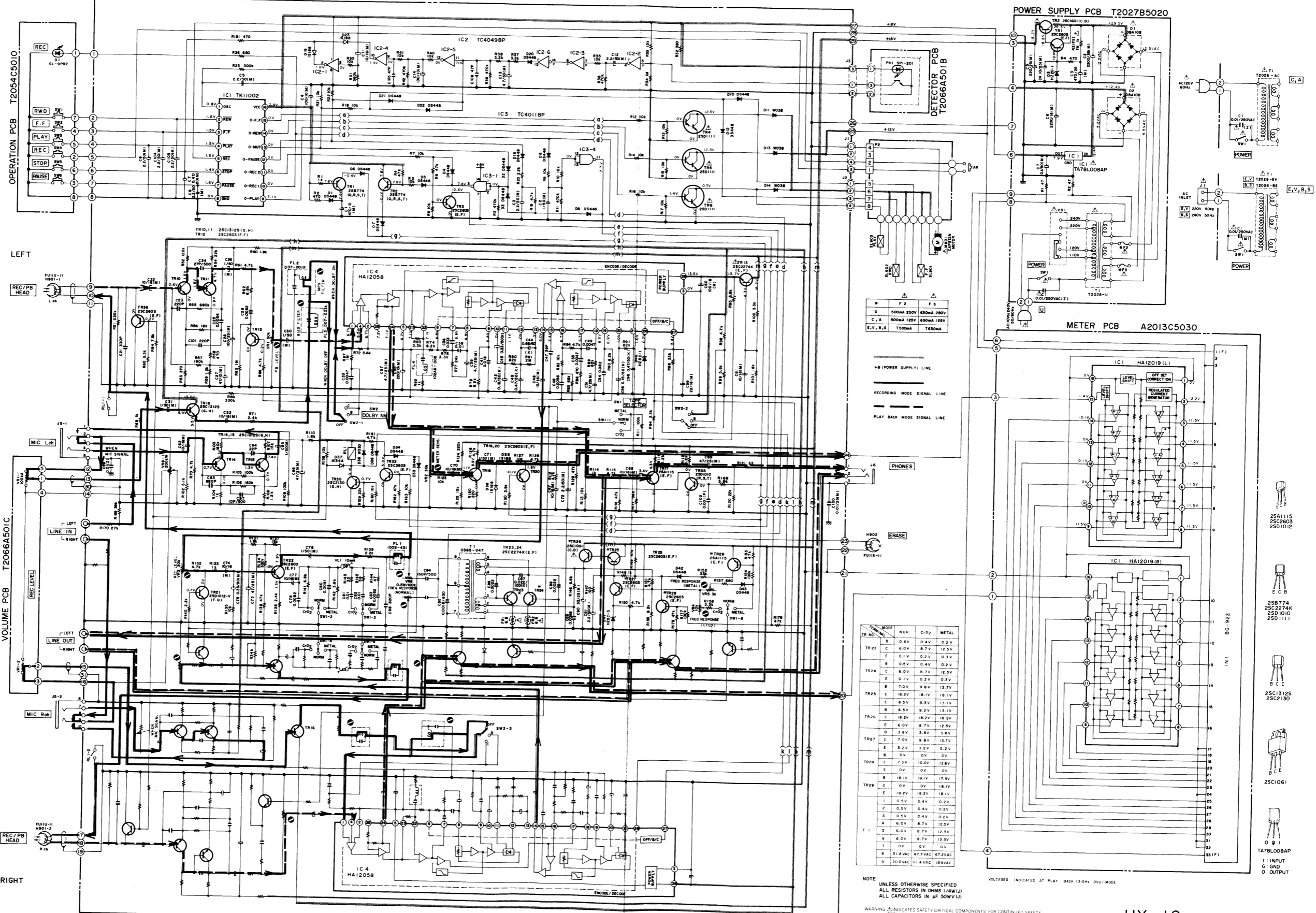

LEFT



VOLUME PCB T2066A501C



RIGHT



PREAMP PCB T2066A501A

POWER SUPPLY PCB T2027B5020

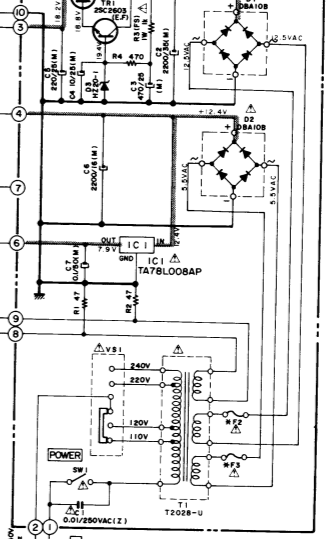

METER PCB A2013C5030

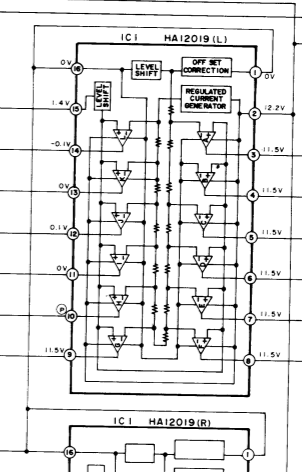

W	A	F 3
U	500MA 250V	830MA 280V
C, A	500MA 125V	830MA 125V
E, V, B, S	T500MA	T830MA

— 48 (POWER SUPPLY) LINE
 - - - RECORDING MODE SIGNAL LINE
 - - - PLAY BACK MODE SIGNAL LINE

TR NO.	TERMINAL	MODE	NOR	C102	METAL
TR 23	A	0.5V	0.4V	0.2V	
	B	6.0V	8.7V	12.5V	
	C	0.1V	0.2V	0.3V	
TR 24	A	0.5V	0.4V	0.2V	
	B	6.0V	8.7V	12.5V	
	C	0.1V	0.2V	0.3V	
TR 25	A	7.0V	9.8V	13.7V	
	B	18.2V	18.1V	18.1V	
	C	6.5V	9.3V	13.1V	
TR 26	A	18.2V	18.2V	18.2V	
	B	6.0V	8.7V	12.5V	
	C	3.8V	3.8V	3.8V	
TR 27	A	7.0V	9.8V	13.7V	
	B	3.2V	3.2V	3.2V	
	C	0V	0V	0V	
TR 28	A	7.3V	10.0V	13.9V	
	B	0V	0V	0V	
	C	0V	0V	0V	
TR 29	A	18.1V	18.1V	17.5V	
	B	0V	0V	18.1V	
	C	18.2V	18.2V	18.1V	
T 1	1	0.5V	0.4V	0.2V	
	2	0.5V	0.4V	0.2V	
	3	0.5V	0.4V	0.2V	
	4	6.0V	8.7V	12.5V	
	5	6.0V	8.7V	12.5V	
	6	6.0V	8.7V	12.5V	
	7	0V	0V	0V	
	8	51.8VAC	47.7VAC	67.2VAC	
	9	70.0VAC	111.4VAC	155VAC	

NOTE
 UNLESS OTHERWISE SPECIFIED
 ALL RESISTORS IN OHMS (1/4W/1%)
 ALL CAPACITORS IN μF (50WV/1%)

WARNING: INDICATES SAFETY CRITICAL COMPONENTS FOR CONTINUED SAFETY.
 REPLACE SAFETY CRITICAL COMPONENTS ONLY WITH MANUFACTURER'S
 RECOMMENDED PARTS.
 AVERTISSEMENT: Δ INDIQUE LES COMPOSANTS CRITIQUES DE SECURITE.
 POUR MAINTENIR LE DEGRE DE SECURITE DE L'APPAREIL,
 NE REMPLACEZ QUE DES PIECES RECOMMANDEES PAR LE FABRICANT.

VOLTAGES INDICATED AT PLAY BACK (30Hz) 0VU; MODE

HX-1C
 SCHEMATIC DIAGRAM
 No.2-2 840111A