

Service Manual

CD MICRO SYSTEM

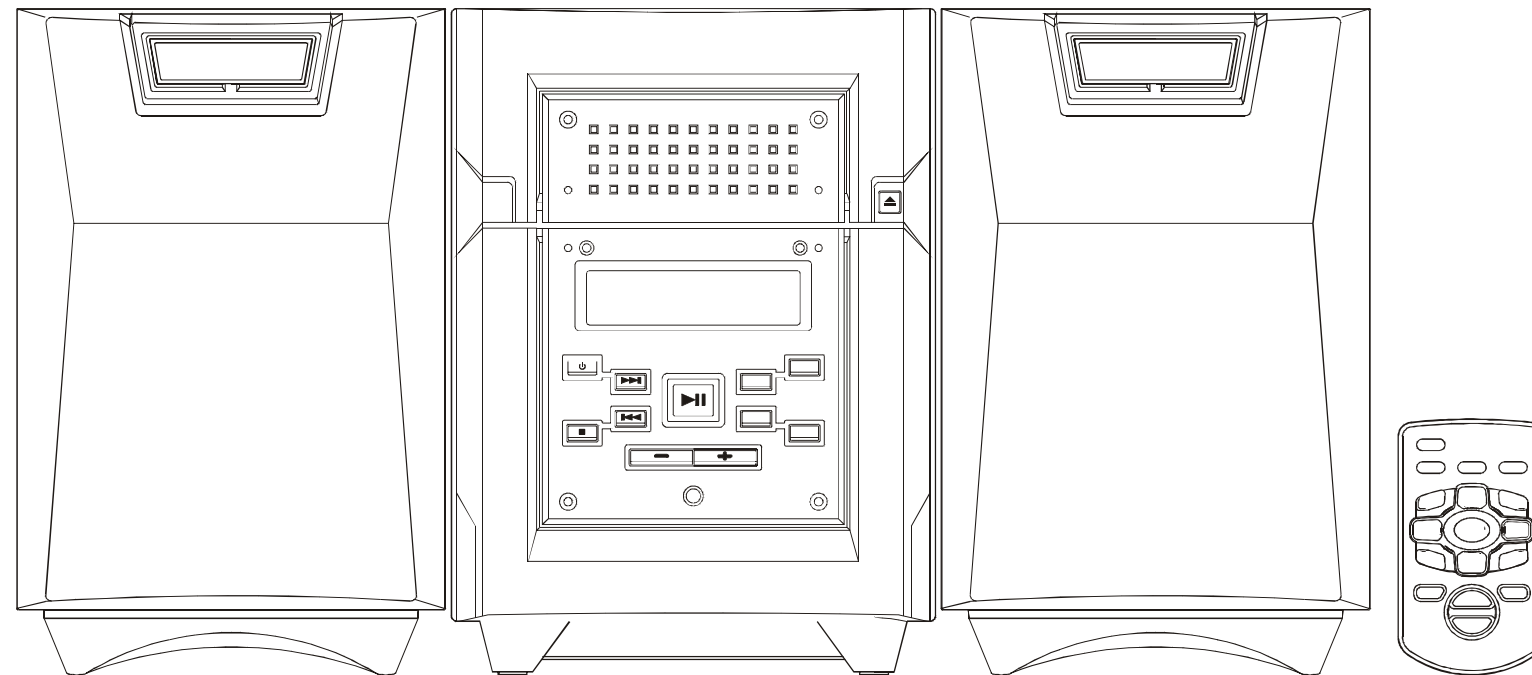

QX-D3305

CONTENTS

	Page
Performance Specifications	1
Electrical Parts List	4
Printed Circuit Boards	13
Wiring Diagram	21
Schematic Diagrams	23
Alignment Set-up Procedures	29
Equipment Connection Diagrams	30
Voltage Chart	32
IC Lead Identification and Internal Diagrams	35
Block Diagrams	39
Exploded Drawing Parts List	42
Exploded Drawings	46

PRODUCT SAFETY NOTICE

Many electrical and mechanical parts in this chassis have special safety characteristics. These safety characteristics often pass unnoticed and the protection afforded by them cannot necessarily be obtained by using replacement components rated for higher voltage, wattage, etc. Replacement parts that have these special safety characteristics are identified in this manual and its supplements; electrical components having such features are identified by ⚠ in the schematic diagram and the parts list.

Before replacing any of these components, read the parts list in this manual carefully. The use of substitute replacement parts that do not have the same safety characteristics as specified in the parts list may create shock, fire or other hazards.

PERFORMANCE SPECIFICATIONS

GENERAL TEST CONDITION	
Power Supply	: AC 230V 50Hz
Output Load	: 4 ohm non-reactive
Reference Output	: 500 mW, 4 ohm
Input Signal Source	: External AM Loop Antenna 75 ohm Dummy for FM
Modulation	: 30% 400Hz for AM 80% for Power 75kHz Deviation 1000Hz for FM 1kHz, 750mV @ Aux Input
Remarks	: 7.5kHz Pilot Tone 40kHz L+R 1000Hz

CD SECTION				
	TEST ITEMS	UNIT	NOMINAL	LIMIT
1.	10% Dis. Output Power (1kHz, 0dB)	W	5	4.5
2.	Frequency Response (100Hz-20kHz/1kHz, 0dB)	dB	±1	±6
3.	De-emphasis Response (1kHz, 0dB/5K, -5dB/16kHz, -9dB)	dB	±2	±4
4.	Channel Balance (1kHz, 0dB)	dB	1	2
*5.	Channel Separation (1kHz, 0dB)	dB	45	40
*6.	T.H.D. + Noise (1kHz, 0dB)	%	0.3	1.0
*7.	S/N Ratio (1HF-A) (1kHz, 0dB)	dB	60	55
8.	CD Speed (1000Hz)	Hz	-	±1
*9.	Dynamic Range	dB	80	70
10.	Wedge	µm	-	600
11.	Black Dot	µm	800	600
12.	Finger Print	Track	-	No. 18
13.	Eccentricity	TCD-712 ABEX µm	-	150
14.	Vertical Deviation	TCD-731R ABEX mm	-	>0.8
15.	Seaching Time	TN01-TN024 Sec.	5	8
		TN024-TN01 Sec.	5	8
16.	Minimum Operation Voltage	%	85	90
17.	CD Max. Vol. Hum	mV	5	10

*with external "A" CURE L.P.F.
ITEM 1 - 9 Test Disc "CBD SONY YEDS7"
ITEM 10 - 12 Test Disc "PHILIPS 444A"
ITEM 15 Test Disc "PHILIPS 444"

Level Matching
Aux 750 mV

AM 55% 5mV	dB	-6	±3
FM 40kHz 1mV	dB		±3
CD -10dB	dB		±3
MTT-112N	dB		±3

PERFORMANCE SPECIFICATIONS - CONTINUED

AM SECTION, AMPLITUDE MODULATION				
	TEST ITEMS	UNIT	NOMINAL	LIMIT
1.	Tuning Range	kHz	522-1620	-
2.	I. F.	kHz	450	±3
3.	S/N 10mV/m	0.999MHz dB	36	30
4.	Sens. (at S/N 20dB)	0.603MHz µV/m	997	1995
		0.999MHz µV/m	997	1995
		1.404MHz µV/m	997	1995
5.	I. F. Rejection	0.603MHz dB	50	46
6.	Image Rejection	1.404MHz dB	30	24
7.	Spurious Rejection	dB	35	25
8.	Bandwidth, -6 dB, at (Max. Sens. +6 dB)	0.999MHz kHz	6	4 - 9
9.	ACA (±9 kHz) Input	0.999MHz dB	20	15
10.	AGC Figure Merit	100mV/m dB	45	40
11.	Distortion, 5mV/m, 30%	%	1	3
	80%	%	3	6
12.	10% THD Power AC	W	5	4.5
13.	a. Tweet (2nd 900kHz & 3rd 1350kHz) at 75 dB I/P	dB	15	10
14.	Audio Fidelity, Centre ± (6) dB	Hz	60/2200	120/2000
15.	Low Voltage AC	%	80	85
16.	a. Mod. Hum 10mV/m	dB	36	30
	b. Hum at Min. Vol.	mV	1	3
17.	Auto Stop Sens.	dB	64	70
18.	Step Frequency	kHz	-	9

CASSETTE SECTION				
	TEST ITEMS	UNIT	NOMINAL	LIMIT
A (PLAYBACK)				
1.	Tape Speed (MTT-111N)	%	±1	±3
2.	Wow & Flutter JIS WTD (MTT-111N)	%	0.25	0.38
3.	Take Up Torque (PLAY)	g-cm	30	60
4.	F. F. / Rew. Torque	g-cm	60	140
5.	Output Power (MTT-112BN) 10% THD	W	5	4.5
6.	S/N Ratio (MTT-112BN)	dB	45	40
7.	T. H. Distortion (MTT-112BN)	%	2	3
8.	Frequency Response (MTT-257H)	125Hz dB	±3	±6
		6.3kHz dB	±3	±6
9.	Separation (MTT-141N) w/BPF	dB	40	30
10.	Cross Talk (X- BASS OFF) w/BPF (MTT-121N)	dB	55	45
11.	Hum & Noise VR MAX	(w/o Tape) mV	30	50
	VR MIN	(w/o Tape) mV	1	3
B (RECORD)				
1.	T. H. / Distortion	%	4	8
2.	Erase Ratio Effect (MTT-112BN) for Level	dB	55	48
3.	Rec. / Playback Level Difference (Radio)	dB	2	4
4.	Rec. / Play S/N Ratio (with A Filter)	dB	40	35
5.	Frequency Response (MTT-257)	125Hz dB	±4	±7
	(Ref: 1kHz 0dB)	6.3kHz dB	±4	±7

Remarks:

All measurement should be done in Bypass mode without X-Bass/Tone...effect.

PERFORMANCE SPECIFICATIONS - CONTINUED

FM SECTION, FREQUENCY MODULATION						
	TEST ITEMS		UNIT	NOMINAL	LIMIT	
1.	Tuning Range		MHz	87.5-108	-	
2.	I. F.		MHz	10.7	±0.3	
3.	30dB S/N	90MHz	µV	22	26	
		98MHz	µV	22	26	
		106MHz	µV	22	26	
4.	-3dB Limit Sens.		dB	16	30	
5.	I. F. Reection		98MHz	dB	60	50
6.	Image Rejection		106MHz	dB	30	22
7.	Spurious Rejection (F + 0.535 MHz) (Max. Sens. +6dB)		dB	40	35	
8.	AM Suppression (60dB I/P)		dB	45	30	
9.	Mod. Hum (60dB I/P)		dB	48	42	
10.	Distortion at 1mV/m (Mono)		%	1	2	
	100mV/m		75kHz	%		
11.	Audio Fidelity, (-3dB) (Pre-emphass) (75µS)/(50µS)		Hz	60/9000	120/6000	
12.	Power Out, Max. AC		W	6.5	5.5	
	10% THD		W	5	4.5	
13.	Low Voltage AC		%	80	85	
14.	S/N Ratio at 1mV/m		98MHz	dB	55	46
15.	Alternate Channel Selective ±400kHz		dB	25	18	
16.	Stereo Separation		dB	26	22	
17.	19kHz Leak Carrier		dB	32	27	
18.	Stereo Indication		dB	26	30	
19.	Step Frequency		kHz	-	50	
20.	Auto Stop Sens.		dB	30	35	
Remarks:						
NOTE: All measurement should be done in Bypass mode without X-Bass/Tone/...effect.						

AMPLIFIER SECTION						
	TEST ITEMS		UNIT	NOMINAL	LIMIT	
1.	Output Power Per Channel (750mV IN)	10%	1kHz	W	5	4.5
2.	Frequency Response: +/-6dB		(L&R)	Hz/kHz	-	100/20
3.	THD (1kHz, Ref O/P)		(L&R)	%	0.5	1.0
4.	Channel Unbalance	L&R	1kHz	dB	±1	±3
5.	Minimum Vol. Hum (Unwgted/wgtd)			mV	1	3
6.	Maximium Vol. Hum (Unwgted/wgtd)			mV	5	10
7.	X-Bass		100Hz	dB	8	±3
8.	S/N (Unwgted/CCIR-ARM2k)	L&R	1kHz	dB	60	50
9.	Seperation		1kHz	dB	45	40
10.	Cross Talk for Input (AUX/CD-Ref) w/BPF		1kHz	dB	45	40

ELECTRICAL PARTS LIST

Ref. No.	Description	Mfr's Part No.	Qty.
PCB			
TUNER PCB	PCB CD6606-01-01 (94V0)	033-006606-600	1
CASSETTE & CD PCB	PCB CD6606-01-02 (94V0)	033-006606-600	1
POWER PCB	PCB CD6606-01-03 (94V0)	033-006606-600	1
DOOR SW. PCB	PCB CD6606-01-04 (94V0)	033-006606-600	1
CONNECT PCB	PCB CD6606-01-05 (94V0)	033-006606-600	1
MOTOR & LEAF SW. CONNECT PCB	PCB CD6606-01-06 (94V0)	033-006606-600	1
RECTIFIER PCB	PCB CD6606-01-09 150x100x1.6mm/2 (94V0)	033-006606-101	1
KEY & DISPLAY PCB	PCB CD6606-01-08 224x124x1.6mm/2 (94HB)	033-006606-100	1
REMOTE CONTROL SECTION			
	REMOTE CONTROL HANDSET, w/BATTERY, L.GR COLOR (CD330x/CD66xx/CD6821/RV2003)	043-R11817-010	1
AUX SECTION			
RESISTORS [All are +-5% 1/16W (1/8W) tape & wheel resistors unless otherwise specified]			
R501,502	*CdF RESISTOR 47 Kohm	001-047351-016	2
R503,504	RESISTOR 8.2 Kohm	001-082251-016	2
CAPACITORS			
C501,502	ELECT CAP 4.7 MFD/50V +-20% (5x11)	006-004000-50D	2
MISCELLANEOUS			
JK501	PIN JACK #HSP-212V-06 WHITE/RED	118-020212-001	1
CD SECTION			
RESISTORS [All are +-5% 1/16W (1/8W) tape & wheel resistors unless otherwise specified]			
R51,56	*CdF RESISTOR 33 Kohm	001-033351-016	2
R42,58	RESISTOR 56 Kohm	001-056351-016	2
R60	*CdF RESISTOR 10 ohm	001-010051-016	1
R5,6,7,9,13,28,29,30,38,40,43,57, LM-CL1	*CdF RESISTOR 1 Kohm	001-010251-016	13
R1,16,20,25,26,27,31,37,39,47,48,49, 50,59,61,88	*CdF RESISTOR 10 Kohm	001-010351-016	16
R11,17	*CdF RESISTOR 100 Kohm	001-010451-016	2
R34	*CdF RESISTOR 15 Kohm	001-015351-016	1
R41	*CdF RESISTOR 220 ohm	001-022151-016	1
R45	*CdF RESISTOR 2.2 Kohm	001-022251-016	1
R23,24,44	*CdF RESISTOR 22 Kohm	001-022351-016	3
R33	RESISTOR 220 Kohm	001-022451-016	1
R21,22	RESISTOR 270 ohm	001-027151-016	2
R36	*CdF RESISTOR 3.3 Kohm	001-033251-016	1
R15	RESISTOR 39 Kohm	001-039351-016	1
R10,14	*CdF RESISTOR 4.7 Kohm	001-047251-016	2
R32,46,52,53,54,55,86	*CdF RESISTOR 47 Kohm	001-047351-016	7
R35	RESISTOR 5.6 Kohm	001-056251-016	1
R12	RESISTOR 680 ohm	001-068151-016	1
R4	RESISTOR 91 ohm	001-091051-016	1
CAPACITORS			
C5,6,17,22,39,40,41,42,47	(F003-010380-025) CERAMIC CAP 0.01 uF/ 50V +80%-20%	003-010380-050	9
C4,23,25,26,27,29,30,53,54	CERAMIC CAP 0.1 uF/16V +80%-20%	003-010480-016	9
C8,12	CERAMIC CAP 0.002 uF/50V +80%-20%	003-020280-050	2
C43	CERAMIC CAP 47 pF/50V +-10%	003-047010-050	1
C35,36	CERAMIC CAP 470 pF/50V +-10% TAPING (B TYPE/4mm)	003-047110-051	2
C31,32,33,34,50	CERAMIC CAP 0.047 uF/50V +80%-20%	003-047380-050	5
C61	CERAMIC CAP 0.0047 uF/16V +80%-20% (EP050YF472Z) (AXIAL TAPED 52mm)	003-247280-016	1

ELECTRICAL PARTS LIST - CONTINUED

Ref. No.	Description	Mfr's Part No.	Qty.
C56	CERAMIC CAP 56 pF/50V +-10%	003-056010-050	1
C7	CERAMIC CAP 100 pF/50V +-5% (NPO) (CC45-CH1H101J/RBU04CH101J-L)	003-410150-050	1
C55	CERAMIC CAP 1 pF/50V +-0.25pF (NPO) (CC45-CH1H010CY)	003-410830-050	1
C19,20	CERAMIC CAP 15 pF/50V +-5% (NPO) (CC45-CH1H150J/RBU04CH150J-L)	003-415050-050	2
C15,16	CERAMIC CAP 27 pF/50V +-5% (NPO) (CC45-CH1H270J/RBU04CH270J-L)	003-427050-050	2
C45	@ MYLAR CAP 0.015 uF/100V +-5%	004-015350-100	1
C51,52	@ MYLAR CAP 0.22 uF/100V +-10%	004-022410-100	2
C38	@ MYLAR CAP 0.0027 uF/100V +-10%	004-027210-100	1
C37	@ MYLAR CAP 0.0047 uF/100V +-10%	004-047210-100	1
C10,11	ELECT CAP 3.3 MFD/50V +-20% (5x11)	006-003000-50D	2
C63	*CdF (F006-010000-16C) ELECT CAP 10 MFD/50V +-20% (VX/5x11)	006-010000-50C	1
C1,18,21,60,62	*CdF ELECT CAP 100 MFD/10V +-20% (VX/5x11)	006-010100-10C	5
C9,24	*CdF ELECT CAP 1000 MFD/10V +-20% (VX/10x12)	006-010200-10C	2
C3,13,14	ELECT CAP 22 MFD/25V +-20% (VX/5x11)	006-022000-25C	3
C2,28,44,46,48,57,58,59	*CdF ELECT CAP 47 MFD/16V +-20% (VX SERIES/5x11)	006-047000-16C	8
TRANSISTORS			
Q2,3	TRLNPSST-TAP&TO-092 3CG1015/ 2SA1015	008-610150-000	2
Q4,5,7	TRLNPNPWR-TAP&TO-092 3DG1815	008-618150-000	3
Q1,6	TRLNPNPWR-TAP&TO-092 3CA8550	008-685500-000	2
CRYSTAL			
X2	CRYSTAL 75.0 KHz +-20ppm TF26-75	009-375000-003	1
INTEGRATED CIRCUITS			
IC3	ICMOTORDRIVER-04CH TA2092N (TOSHIBA) (87-A20-157-01J/AIWA)	010-832092-000	1
IC2	ICCDP-153CDSP+ASP TA2153FN	010-832153-000	1
IC1	ICMCU-09K-LCD TC94A09F-202	010-849409-000	1
DIODES			
D2,3,4,5,6,8,10,11	DIODE IN-4148 ROHM/TELEFUNKEN TAP**50 KEL(NS)(TAP:52mm)/NS(FAIRCHILD)/SEMTECH	011-004148-000	8
D7	ZENER IN-5228B, 3.9V, 1/2W	011-010039-120	1
D1,9	RECTIFIER IN-4001B/IN-4001 (DC)	011-024001-000	2
INDUCTOR			
L1	INDUCTOR 10 uH CEC-100K/ZHF103-100KT +-10% (CdF)	018-010016-000	1
RESONATOR			
X1	CERAMIC RESONATOR 16.93 MHz ZTA16.93MX (ZHEJIANG JIAKANG)	020-001693-005	1
MISCELLANEOUS			
SEN1	CD&-TLB-01-SAMG-N CD MECHANISM CMS-B31BG6U REMOTE/CONTROL PHOTO RECEIVER ROHM/RPM7138-V4	153-000316-000 111-007138-000	1 1
CD DOOR SECTION			
RESISTORS [All are +-5% 1/16W (1/8W) tape & wheel resistors unless otherwise specified]			
R95,96	*CdF RESISTOR 1 Kohm	001-010251-016	2

ELECTRICAL PARTS LIST - CONTINUED

Ref. No.	Description	Mfr's Part No.	Qty.
R97,98	*CdF RESISTOR 10 Kohm	001-010351-016	2
R91,92	*CdF RESISTOR 220 ohm	001-022151-016	2
R90	RESISTOR 5.6 ohm +-5% 1/4W	001-056850-014	1
CAPACITORS			
C94	CERAMIC CAP 0.1 uF/16V +80%-20%	003-010480-016	1
C91,92,93	ELECT CAP 470 MFD/10V +-20% (8x11.5)	006-047100-10D	3
C95,96	ELECT CAP 220 MFD/10V +-20% (SMALL SIZE) (6.3x7)	006-122100-10D	2
TRANSISTORS			
Q93,94	TRLNPNPWR-TAP&TO-092 3DA8050	008-680500-000	2
Q91,92	TRLNPNPWR-TAP&TO-092 3CA8550	008-685500-000	2
RESONATORS			
SW91	LEAF SWITCH LSA-1120Y2/LS35 (CdF)	022-001120-002	1
SW92	MICRO SWITCH MQS-2	023-000002-000	1
MISCELLANEOUS			
MOT1	MOTOR-DC-012V-NORMAL 12V #WRF-370C-15370	151-121537-001	1
CONTROL & DISPLAY SECTION			
RESISTORS [All are +-5% 1/16W (1/8W) tape & wheel resistors unless otherwise specified]			
R72	*CdF RESISTOR 10 Kohm	001-010351-016	1
R78,81	*CdF RESISTOR 1.5K	001-015251-016	2
R77,80	RESISTOR 2 Kohm	001-020251-016	2
R76,79	RESISTOR 2.7 Kohm	001-027251-016	2
R74	RESISTOR 3.9K	001-039251-016	1
R75	RESISTOR 6.2 Kohm	001-062251-016	1
R71,73	*CdF RESISTOR 6.8 Kohm	001-068251-016	2
CAPACITOR			
C399	(F003-010380-025) CERAMIC CAP 0.01uF/50V	003-010380-050	1
SWITCHES			
SW1,2,3,4,5,6,7,8,9,10,11,12	*CdF TACT SWITCH 4P 4.3mm 100G #1102-4 (=021-008300-000)	021-110200-001	12
MISCELLANEOUS			
D303	LED-G-3MM&-S-&&&-&&& W03304PGSC-KL 3mm PURE GREEN WATER CLEAR SUPER BRIGHT	110-033041-013	1
LCD1	LCD-P-&&D-80x25SM022P JT4-01600 80x25x2.8mm TRANSMISSIVE/POSITIVE	112-001600-000	1
GENERAL SECTION			
WIRES			
SW7,8	JP WIRE AWG26#1007 3x3mm 80mm YELLOW	051-673080-010	2
W6	JP WIRE AWG26#1007 3x3mm 100mm ORANGE	051-673100-003	1
W5	JP WIRE AWG26#1007 3x3mm 100mm BLACK	051-673100-009	1
W3	JP WIRE AWG26#1007 3x3mm 200mm RED (CdF)	051-673200-006	1
W4	JP WIRE AWG26#1007 3x3mm 200mm BLACK (CdF)	051-673200-009	1
CN1	FFC CABLE 16 PINS L=65mm P:1mm KLV9586-1A (01-0735C-3F16-057S04N08-08NN) (CdF)	040-160065-102	1
CN4,5	FFC CABLE 16 PINS L=220mm PITCH:1mm RHW0276-1B (02-0735C-3F16-212S04N08-08NN)	040-160220-100	2
CN6	CONN PIN 2 PINS (3.5+193+3.5) PITCH 2mm AWG26#UL2651 GREY COLOR	050-020200-200	1
CN18,19	CONN PIN 4 PINS (3.5+33+3.5) PITCH 2mm AWG26#UL2651 FLAT CABLE GREY COLOR	050-040040-200	2
CN17	CONN PIN 5 PINS (3.5+43+3.5) PITCH 2mm AWG26#UL2651	050-050050-200	1
CN13	CONN PIN 5 PINS (3.5+203+3.5) PITCH 2mm AWG26#2651 FLAT CABLE GREY COLOR	050-050210-200	1

ELECTRICAL PARTS LIST - CONTINUED

Ref. No.	Description	Mfr's Part No.	Qty.
CN16	CONN PIN 8 PINS (3.5+53+3.5) PITCH:2mm	050-080060-200	1
	AWG26#UL2651 FLAT CABLE GREY COLOR		
CN15	CONN PIN 8 PINS (3.5+203+3.5) PITCH 2mm	050-080210-200	1
	AWG26#UL2651 FLAT CABLE GREY COLOR		
	CONN PIN 11 PINS (3.5+33+3.5) PITCH 2mm	050-110040-200	1
	AWG26#UL2651 GREY		
CN21	HSG CD138-4B(C) PEC 2507-H-4 w/160mm	136-040138-C00	1
	BLK,RED,VIO,BLUE AWG26#UL1007 SLDG 4mm		
CN11	HSG CD368-4B(C) PEC 2507-H-4 w/234mm BLK	136-040368-C01	1
	SHIELD WIRE AWG30#UL2547/3C SLDG.2mm		
LSW PCB TO CD PCB	HSG VCD30D-4A JST PHR-04 w/150mm	136-04V30D-200	1
	BLK,BRN,RED,ORG AWG28#UL1007 SLDG 3mm		
CN3	HSG CDR931-5 JST-PHR/2 w/150mm BLK,RD,	136-050931-200	1
	OR,YELL,GN AWG28#1095 JP 3mm		
	HSG CD769C-6(C) PEC 2001H-6 TO PEC	136-06769C-B00	1
	2003H-6 w/180mm RED,BLKx5 AWG28#UL1571		
MISCELLANEOUS			
	AM LOOP ANT .388-88 & 388-89 MOLD BK (ABS)	132-020388-882	1
	5264-2 2.54mm w/5750mm BK AWG26#UL1007		
CN101	HEADER MOLEX 2 PINS 5268-02A PITCH 2.5mm	135-005268-020	1
	HORIZONTAL TYPE		
HR4	FFC CONN SOCKET 16P P:1 TAIKO DENKI	135-006116-160	1
	6116-0101/CFF7816-01-01/TOC-B16X-G2) (CdF)		
HR11,21	HEADER 4PINS PEC #2507-WS-4 P:2.5mm	135-2507WS-040	2
	VERTICAL REPLACE:135-005267-040		
HR04	FFC/FPC CONNECTOR 16 PINS PITCH:1mm	135-D100DR-160	1
	#D100-DRA-16 DOUBLE CONTACT (CdF)		
HR5,05	FFC CONNECTOR 16 PINS P:1mm D100-SRV-16U/	135-D100SR-160	2
	LWFPC1.0-R-16P RIGHT-ANGLE (CdF)		
HR1	FFC/FPC CONNECTOR 16 PINS PITCH:1mm	135-D100SS-160	1
	#D100-SSA-16 VERTICAL/TOP CONTACT (CdF)		
HR12	HEADER CTL 4 PINS PHS-04 PITCH 2mm	135-PHS040-040	1
	STRAIGHT TYPE WHT COLOR (MARKING:HR)		
HR3	HEADER CTL 5 PINS PHS-05 PITCH 2mm	135-PHS050-050	1
	STRAIGHT TYPE WHT COLOR (MARKING:HR)		
FM ANT WIRE	FERRITE CORE R0002-M191812100AF3	032-219181-000	1
	T18x12x10 OD:18mm,ID:10mm,T:12mm		
AC CORD	FERRITE CORE FYE-T-062/T25x15x10/	032-225015-010	1
	F2515100D OD:25mm,ID:15mm,T:10mm		
L305,306,307,501,502,503	TOROIDAL COIL 100 uH RI63-870001 (COILS)	037-870001-A00	6
T901	⚠ PT005WEI57/30&FSBEN& 230V:15.5V/11.2V	123-486201-140	1
	w/FUSE 115°C (HCD6201ENFN)		
	⚠ (F134-220120-001) PLA-VDE-6'06"-VDE-MG	134-B10331-004	1
	VDE APP.CORD 6.5'		
POWER AMP. SECTION			
RESISTORS [All are +5% 1/16W (1/8W) tape & wheel resistors unless otherwise specified]			
R329,331,359	*CdF RESISTOR 100 ohm	001-010151-016	3
R305,308,309,344,351,352,353,511,512	*CdF RESISTOR 1 Kohm	001-010251-016	9
R303,341,342,345,346,347,355,358,505,506,510,513,514	*CdF RESISTOR 10 Kohm	001-010351-016	13
R328,330,349,350	*CdF RESISTOR 100 Kohm	001-010451-016	4
R362	*CdF RESISTOR 15 Kohm	001-015351-016	1
R339,363,377	*CdF RESISTOR 220 ohm	001-022151-016	3

ELECTRICAL PARTS LIST - CONTINUED

Ref. No.	Description	Mfr's Part No.	Qty.
R304,334,379	*CdF RESISTOR 2.2 Kohm	001-022251-016	3
R388	*CdF RESISTOR 22 Kohm	001-022351-016	1
R314	RESISTOR 270 ohm	001-027151-016	1
R365	RESISTOR 2.7 Kohm	001-027251-016	1
R509	*CdF RESISTOR 330 ohm	001-033151-016	1
R306	*CdF RESISTOR 3.3 Kohm	001-033251-016	1
R336,338	*CdF RESISTOR 33 Kohm	001-033351-016	2
R340,343	*CdF RESISTOR 470 ohm	001-047151-016	2
R356,374,375,376,389	*CdF RESISTOR 4.7 Kohm	001-047251-016	5
R354,364	RESISTOR 5.1 Kohm	001-051251-016	2
R307	RESISTOR 68 ohm	001-068051-016	1
R348	RESISTOR 680 ohm	001-068151-016	1
R301,302	RESISTOR 8.2 Kohm	001-082251-016	2
R507,508	RESISTOR 220 Kohm	001-022451-016	2
CAPACITORS			
C330,334	CERAMIC CAP 0.001uF/50V +80%-20%	003-010280-050	2
C370,373	CERAMIC CAP 120 pF/50V +-10%	003-012110-050	2
C374	CERAMIC CAP 0.02 uF/50V +80%-20%	003-020380-050	1
C339,342	@ MYLAR CAP 0.1 uF/50V +-10%	004-010410-050	2
C301,302	@ MYLAR CAP 0.0015 uF/100V +-10%	004-015210-100	2
C329,333,359,360,381,382	ELECT CAP 2.2 MFD/50V +-20% (5x11)	006-002000-50D	6
C356,357,366,367	ELECT CAP 10 MFD/50V +-20% (5x11)	006-010000-50D	4
C336	ELECT CAP 100 MFD/10V +-20% (5x11)	006-010100-10D	1
C331,335,343,345	ELECT CAP 100 MFD/16V +-20% (5x11)	006-010100-16D	4
C338,341	ELECT CAP 1000 MFD/16V +-20% (10x20)	006-010200-16D	2
C386	ELECT CAP 22 MFD/25V +-20% (5x11)	006-022000-25D	1
C368,375	ELECT CAP 220 MFD/10V +-20% (6.3x11)	006-022100-10D	2
C362	ELECT CAP 220 MFD/16V +-20% (8x11.5)	006-022100-16D	1
C332,350	ELECT CAP 220 MFD/25V +-20% (8x11.5)	006-022100-25D	2
C361	ELECT CAP 3300 MFD/25V +-20% (16x31.5)	006-033200-25D	1
C337,340,344	*CdF ELECT CAP 47 MFD/16V +-20% (5x11)	006-047000-16D	3
C322,328	(F003-010380-025) CERAMIC CAP 0.01 uF/50V +80%-20%	003-010380-050	2
C514	CERAMIC CAP 0.1 uF/16V +80%-20%	003-010480-016	1
C371,372	@ MYLAR CAP 0.068 uF/100V +-10%	004-068310-100	2
C505,506	*CdF ELECT CAP 0.1 MFD/50V +-20% (VX/5x11)	006-000100-50C	2
C515,516	ELECT CAP 1 MFD/50V +-20% (5x11)	006-001000-50D	2
C503,504,507,508,509,510,511,512	ELECT CAP 4.7 MFD/50V +-20% (5x11)	006-004000-50D	8
C327	ELECT CAP 100 MFD/25V +-20% (6.3x11)	006-010100-25D	1
C513	ELECT CAP 220 MFD/10V +-20% (6.3x11)	006-022100-10D	1
C321	ELECT CAP 470 MFD/10V +-20% (8x11.5)	006-047100-10D	1
TRANSISTORS			
Q307	TRLNPPWR-BUK&TO-220 2SB1566E/F (FOSHAN)	008-601566-000	1
Q309	TRLNPPWR-TAP&TO-092 3CG562	008-605620-000	1
Q304	TRLNPSST-TAP&TO-092 3CG1015/2SA1015	008-610150-000	1
Q303,308,310,321,322,506,507	TRLNPSST-TAP&TO-092 3DG1815	008-618150-000	7
Q305,306	TRANSISTOR 2SK2541-T/2SK2541 (NEC)	008-902541-000	2
INTEGRATED CIRCUITS			
IC301	ICAMP-POWR-ST-00005W BA5415A, R-OHM POWER AMPLIFIER 5Wx2	010-405415-000	1
IC501	(F010-404052-000/010-354052-00A) ICLOGIC BU4052BC/B HCF4052BE (87-017-804-01G)	010-354052-000	1

ELECTRICAL PARTS LIST - CONTINUED

Ref. No.	Description	Mfr's Part No.	Qty.
IC309	I.C. L7806CV VOLTAGE REGULATOR	010-727806-000	1
IC502	ICELEVOL-078STEP TC9260P	010-849260-000	1
DIODES			
D305,306,307,321,323,329,314	DIODE IN-4148 ROHM/TELEFUNKEN TAP**50 KEL(NS)(TAP:52mm)/NS(FAIRCHILD)/SEMTECH	011-004148-000	7
ZD303	ZENER DIODE MTZJ2.4A 2.4V	011-010024-001	1
DZ301	ZENER IN-5237B, 8.2V, 1/2W	011-010082-120	1
D330	RECTIFIER IN-4001B/IN-4001(DC)	011-024001-000	1
MISCELLANEOUS			
JK301	HEADPHONE JACK STEREO 3.5mm #MSJ-2000 HSJ2000-01-110 (8Z-CS1-604-01) (Cd FREE)	116-002000-352	1
JK302	EXT SP JACK HSP-104V-01/MSP-104V-01 RED,BLK,BLK,RED (PUSH TERMINAL BOARD)	118-040104-000	1
RECTIFIER SECTION			
CAPACITORS			
C901,902,903,904,905,906,907,908	(F003-010380-025) CERAMIC CAP 0.01 uF/ 50V +80%-20%	003-010380-050	8
C909	ELECT CAP 3300 MFD/25V +-20% (16x31.5)	006-033200-25D	1
DIODES			
D905,906,907,908	RECTIFIER IN5391	011-025391-000	4
D901,902,903,904	(F011-005401-000) RECTIFIER IN-5401BL/ IN-5401(DC)	011-025401-000	4
MISCELLANEOUS			
F902	⚠ *CdF FUSE #218002 2A/250V 5x20mm TIME LAG (CULVDE/SEMKO/BSI/CCC/JIS/KOR)	124-020020-001	1
F901	⚠ FUSE #S506/TDS5063153 3.15A/250V 5x20mm TIME LAG (CULVDE/SEMKO/BSI)(BUSSMANN)	124-031520-002	1
TAPE SECTION			
RESISTORS [All are +-5% 1/16W (1/8W) tape & wheel resistors unless otherwise specified]			
R226	*CdF RESISTOR 4.7 Kohm	001-047251-016	1
R225	RESISTOR 5.6 ohm	001-056851-016	1
R227	*CdF RESISTOR 6.8 Kohm	001-068251-016	1
SFR201	*CdF SEMI-FIXED FRB-085-10KOHM	002-103085-000	1
R216,228	*CdF RESISTOR 100 ohm	001-010151-016	2
R207,208	*CdF RESISTOR 1 Kohm	001-010251-016	2
R236	*CdF RESISTOR 10 Kohm	001-010351-016	1
R237	*CdF RESISTOR 100 Kohm	001-010451-016	1
R201,202	*CdF RESISTOR 12 Kohm	001-012351-016	2
R206,214	RESISTOR 18 Kohm	001-018351-016	2
R231	*CdF RESISTOR 22 Kohm	001-022351-016	1
R209	RESISTOR 220 Kohm	001-022451-016	1
R217,218	RESISTOR 2.7 Kohm	001-027251-016	2
R229,230,233,219,221	*CdF RESISTOR 3.3 Kohm	001-033251-016	5
R204,213	RESISTOR 47 ohm	001-047051-016	2
R205,210,212,215	*CdF RESISTOR 4.7 Kohm	001-047251-016	4
R232	*CdF RESISTOR 47 Kohm	001-047351-016	1
R220,222	RESISTOR 68K	001-068351-016	2
R203,211	*CdF RESISTOR 82 Kohm	001-082351-016	2
CAPACITORS			
C217,218	(F004-022310-050) @ MYLAR CAP 0.022 uF/ 100V +-10%	004-022310-100	2
C216	@ MYLAR CAP 0.0039 uF/100V +-10%	004-039210-100	1
C203,205	CERAMIC CAP 0.01 uF/16V +80%-20% (EP050YF103Z) (AXIAL TAPED 52mm)	003-210380-016	2

ELECTRICAL PARTS LIST - CONTINUED

Ref. No.	Description	Mfr's Part No.	Qty.
C202,204	@ MYLAR CAP 0.0015 uF/100V +-10%	004-015210-100	2
C201,212	@ MYLAR CAP 0.0022 uF/100V +-5%	004-022250-100	2
C207,213	@ MYLAR CAP 0.033 uF/100V +-5%	004-033350-100	2
C220	ELECT CAP 100 MFD/25V +-20%	006-010100-25D	1
C230,231	ELECT CAP 1 MFD/50V +-20% (5x11)	006-001000-50D	2
C208,209,210	ELECT CAP 10 MFD/50V +-20% (5x11)	006-010000-50D	3
C219	ELECT CAP 100 MFD/10V +-20% (5x11)	006-010100-10D	1
C214,221	ELECT CAP 220 MFD/10V +-20% (6.3x11)	006-022100-10D	2
C206,211	*CdF ELECT CAP 47 MFD/16V +-20% (5x11)	006-047000-16D	2
TRANSISTORS			
Q204	TRLNPN SST-TAP&TO-092 3CG1015/ 2SA1015	008-610150-000	1
Q202	TRLNPN SST-TAP&TO-092 3DG1815	008-618150-000	1
Q203	TRLNPN SST-TAP&TO-092 3DG1815	008-618150-000	1
DIODES			
D201,202	DIODE IN-4148 ROHM/TELEFUNKEN TAP**50 KEL(NS)(TAP:52mm)/NS(FAIRCHILD)/SEMTECH	011-004148-000	2
INDUCTOR			
T201	*CdF IFT 4A-363R(B), 10mm	012-003630-010	1
INTEGRATED CIRCUIT			
IC201	ICAMP-PRE-ST-W/ALC D3308 (CHMC)	010-333308-000	1
DIODES			
D203,204,205	DIODE IN-4148 ROHM/TELEFUNKEN TAP**50 KEL(NS)(TAP:52mm)/NS(FAIRCHILD)/SEMTECH	011-004148-000	3
SWITCH			
SW201	REC SWITCH 9P2T,2mm PS92D01/ PS92D01A RSD-92D02N-ES (CdF)	024-009220-000	1
MISCELLANEOUS			
	CASSDECK-SM-T-S03+&& TN-9ZR-219 w/o MOTOR,RP HEAD,E HEAD MOTOR-DC-002V-NORMAL 2V #SM2611-13260 (SAMSON MOTOR) ER/HEAD-&&&&&&&&& #6PA (CHENWEI) RP/HEAD-ST-TECHRECO & #T21V1BB0	150-000219-K00	1
		151-021326-000	1
		152-010006-000	1
		152-020211-001	1
GOVERNORS SECTION			
RESISTORS [All are +-5% 1/16W (1/8W) tape & wheel resistors unless otherwise specified]			
R261,262,263	RESISTOR 1.5 ohm	001-015851-016	3
R271,272,273 ,274	RESISTOR 2.2 ohm +-5% 1/2W	001-022850-012	4
R251	*CdF RESISTOR 470 ohm	001-047151-016	1
R252	RESISTOR 820 ohm	001-082151-016	1
R253	RESISTOR 9.1 Kohm	001-091251-016	1
VR251	SEMI-FIXED DIA.8mm 500 ohm DOUBLE CONTACT/HORIZONTAL 3 PINS (CdF)	002-501085-000	1
CAPACITORS			
C255	CERAMIC CAP 0.001 uF/50V +80%-20% (UP050YF102Z) (AXIAL TAPED 52mm)	003-210280-050	1
C254	@ MYLAR CAP 0.1 uF/50V +-10%	004-010410-050	1
C252	ELECT CAP 220 MFD/10V +-20% (6.3x11)	006-022100-10D	1
C251	*CdF ELECT CAP 47 MFD/16V +-20% (VX SERIES/5x11)	006-047000-16C	1
TRANSISTOR			
Q251	TRLNPN PWR-TAP&TO-092 3DA8050	008-680500-000	1
INTEGRATED CIRCUIT			
IC251	IC UTC6650 MOTOR SPEED CONTROL IC	010-396650-000	1

ELECTRICAL PARTS LIST - CONTINUED

Ref. No.	Description	Mfr's Part No.	Qty.
DIODE			
D251	ZENER WZ-033, 3.3V, 1/2W	011-010033-120	1
TUNER SECTION			
RESISTORS [All are +-5% 1/16W (1/8W) tape & wheel resistors unless otherwise specified]			
R121,122	*CdF RESISTOR 12 Kohm	001-012351-016	2
R123,124	*CdF RESISTOR 4.7 Kohm	001-047251-016	2
R141,417	*CdF RESISTOR 100 ohm	001-010151-016	2
R101,114,413	*CdF RESISTOR 1 Kohm	001-010251-016	3
R105,108,111,119,404,405,409,410	*CdF RESISTOR 10 Kohm	001-010351-016	8
R112,113	*CdF RESISTOR 100 Kohm	001-010451-016	2
R130	*CdF RESISTOR 1.5K	001-015251-016	1
R161	*CdF RESISTOR 220 ohm	001-022151-016	1
R110,406,407,408,411,412	*CdF RESISTOR 2.2 Kohm	001-022251-016	6
R127	*CdF RESISTOR 2.2 Mohm	001-022551-016	1
R118,401	*CdF RESISTOR 330 ohm	001-033151-016	2
R106,120	*CdF RESISTOR 3.3 Kohm	001-033251-016	2
R109,128	*CdF RESISTOR 4.7 Kohm	001-047251-016	2
R102,103,129,414,415,416	*CdF RESISTOR 47 Kohm	001-047351-016	6
R104	RESISTOR 68 ohm	001-068051-016	1
R418	*CdF RESISTOR 6.8 Kohm	001-068251-016	1
CAPACITORS			
C124	CERAMIC CAP 12 pF/50V +-5% (NPO) (CC45-CH1H120J/RBU04CH120J-L)	003-412050-050	1
C134,144	@ MYLAR CAP 0.018 uF/100V +-10%	004-018310-100	2
C407,408,409	CERAMIC CAP 100 pF/50V +-10%	003-010110-050	3
C101,103,104,116	CERAMIC CAP 0.001uF/50V +80%-20%	003-010280-050	4
C128,130,142	(F003-010380-025) CERAMIC CAP 0.01 uF/ 50V +80%-20%	003-010380-050	3
C401	CERAMIC CAP 0.002 uF/50V +80%-20%	003-020280-050	1
C105,114,121,122,123,126,132,402	CERAMIC CAP 0.02 uF/50V +80%-20%	003-020380-050	8
C108	CERAMIC CAP 330 pF/50V +-10%	003-033110-050	1
C117	CERAMIC CAP 0.0047 uF/50V +80%-20%	003-047280-050	1
C181	CERAMIC CAP 0.047 uF/50V +80%-20%	003-047380-050	1
C107	CERAMIC CAP 15 pF/50V +-5% (NPO) (CC45-CH1H150J/RBU04CH150J-L)	003-415050-050	1
C106	CERAMIC CAP 22 pF/50V +-5% (NPO) (CC45-CH1H220J/RBU04CH220J-L)	003-422050-050	1
C405,406	CERAMIC CAP 30 pF/50V +-5% (NPO) (CC45-CH1H300J/RBU04CH300J-L)	003-430050-050	2
C135	CERAMIC CAP 5 pF/50V +-0.25pF (NPO) (CC45-CH1H050C/RBU04CH050C-L)	003-450830-050	1
C125	POLY CAP 350 pF/100V +-5% (RADIAL TYPE) (1A351J/MILOSONIC) (PSR351J/HONJU)	005-035100-100	1
C109,110	*CdF ELECT CAP 0.1 MFD/50V +-20% (VX/5x11)	006-000100-50C	2
C112,131	ELECT CAP 0.47 MFD/50V +-20% (5x11)	006-000400-50D	2
C111,119,120	ELECT CAP 1 MFD/50V +-20% (5x11)	006-001000-50D	3
C127	ELECT CAP 3.3 MFD/50V +-20% (VX/5x11)	006-003000-50C	1
C133	ELECT CAP 4.7 MFD/50V +-20% (5x11)	006-004000-50D	1
C404	ELECT CAP 100 MFD/10V +-20% (5x11)	006-010100-10D	1
C141,403	ELECT CAP 220 MFD/10V +-20% (6.3x11)	006-022100-10D	2
C100	ELECT CAP 220 MFD/16V +-20% (8x11.5)	006-022100-16D	1
TC101,102	TRIMMER CAP CVN610 3-10pF WHITE (6x6x5mm) (JIN MYOUNG) (CdF)	007-200610-000	2

ELECTRICAL PARTS LIST - CONTINUED

Ref. No.	Description	Mfr's Part No.	Qty.
INDUCTORS			
L106	IFT 1A784R MW RF, 10mm, BLACK	012-007840-010	1
T103	*CdF IFT 4A-224R, 10mm	012-002240-010	1
T102	IFT 1A612R, 10mm	012-006120-010	1
L101	FM COIL 3T, 5mm, DIA:0.8mm (CS58-862492) (2.5Tx5mmx0.8mm/HEROWELL)	015-030050-008	1
L102	FM COIL 4T, 5mm, DIA:0.8mm (CS58-862493) (3.5Tx5mmx0.8mm/HEROWELL)	015-040050-008	1
L402	*CdF INDUCTOR 100 uH /1128/CEC-101K +-10% LAL03 TB 101K/ZHF0103-101KT	018-010014-000	1
L103	INDUCTOR 10 uH CEC-100K/ZHF0103-100KT +-10% (CdF)	018-010016-000	1
L105	INDUCTOR 2.2uH #LAL02NA2R2K/2.3x3.4 #CEC22-2R2K-823457	018-010227-001	1
FILTERS			
CF101	(F019-000450-002) CERAMIC FILTER LTU450G2/LT450GU	019-000450-012	1
CF103	CERAMIC FILTER L10.7MS2-A(CQ)	019-000107-029	1
BPF101	(F019-100008-001) BANDPASS FILTER GFMB3-1 (LEAD PITCH:2.3mm)	019-100031-001	1
TRANSISTORS			
Q102,103,107	TRLNPNSS-TAP&TO-092 3DG1815	008-618150-000	3
Q108	TRLPNPPWR-TAP&TO-092 3CA8550	008-685500-000	1
Q105,106	TR NPNSST-RAD&SC-072 DTC114YSTP/ DTC114YS	008-800114-000	2
CRYSTAL			
CX101	CRYSTAL 4.500 MHz HC-49/U (CdF+)	009-604500-000	1
INTEGRATED CIRCUITS			
IC101	ICREVD-AFM-TR-IF-MPX TA2149BN (TOSHIBA)	010-832149-001	1
IC401	ICPLL TC9257P (TOSHIBA)	010-849257-001	1
DIODES			
VD103,104	VARI CAP DIODE 2CC149	011-000149-001	2
VD101,102, VT SET TO 1.8V TO 5.5V	VARI CAP DIODE 2CC910	011-000910-000	2
D101,102,103,401	DIODE IN-4148 ROHM/TELEFUNKEN TAP**50 KEL(NS)(TAP:52mm)/NS(FAIRCHILD)/SEMTECH	011-004148-000	4
ZD105,106	ZENER IN-5232B, 5.6V, 1/2W (ROHM)	011-010056-120	2
ZD107	ZENER 10V, 1/2W BL, TOS 05AZ10Z, HITACHI HZ11A3,ROHM MTZJ10 MTZJT-7210 C/D	011-010100-120	1
RESONATOR			
CF102	CERAMIC RESONATOR #CDA10.7MG80-A (FOR IC TA2104)	020-601070-004	1
WIRES			
	(F051-679A20-009) JP WIRE AWG26#1007 3x0mm 1200mm BLACK (Cd FREE)	051-679A20-209	1
MISCELLANEOUS			
FM ANT	SOLDERING PIN	137-300000-002	1
SPEAKER SECTION			
MISCELLANEOUS			
	SPK WIRE UL/CSA AWG22/2C UL2468 1830mm 6' BLACK w/WHT LINE NON-MIGRATION SPK00005*0040HM0010W w/BLACK CAP, FOAM EDGE MAG:60x32x10 #125B58-2	122-002020-605	2
		131-504010-011	2

NOTES:

- " @ " Mylar is a registered trademark of E.I. Du Pont de Nemours and Company.
- ⚠ Symbol in parts list represent safety parts.

PRINTED CIRCUIT BOARDS

TUNER PCB
CD6606-01-01

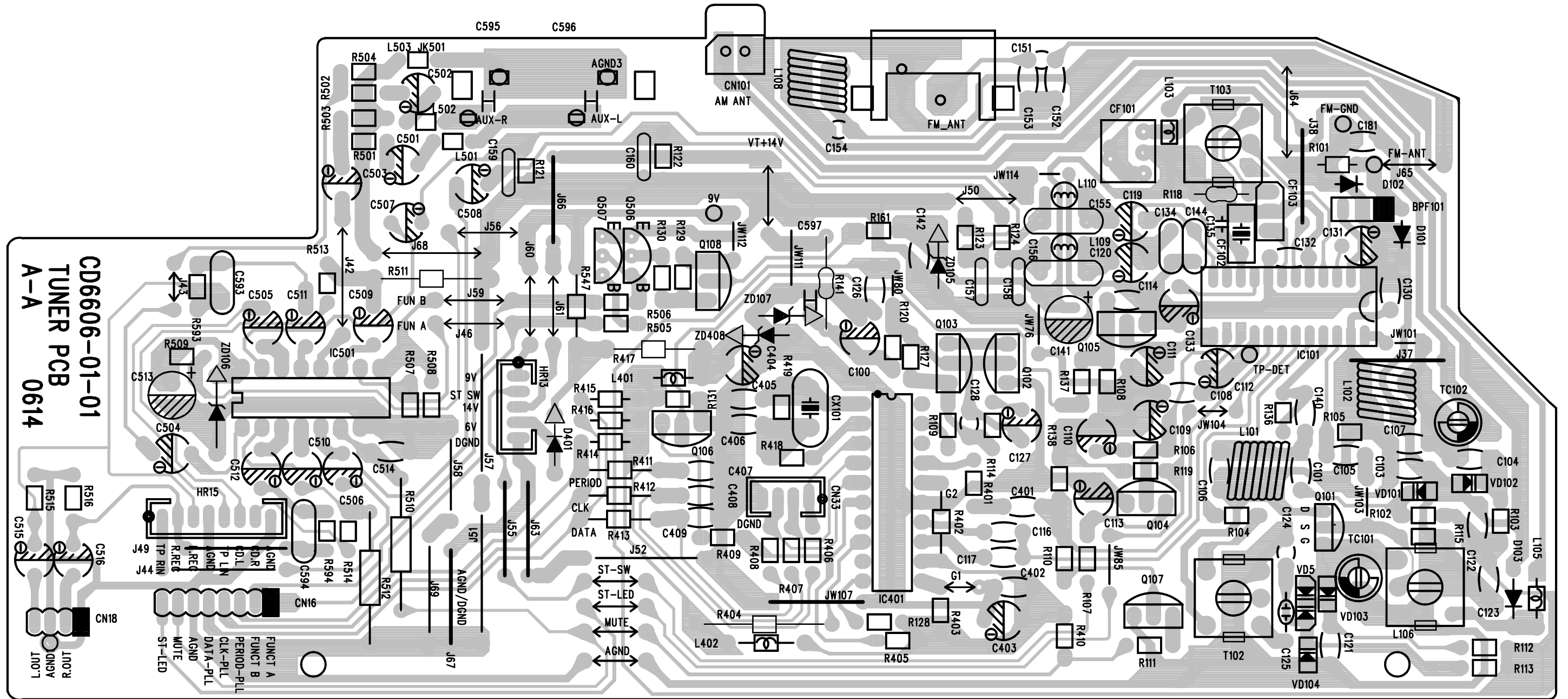

DOOR SW. PCB
CD6606-01-04

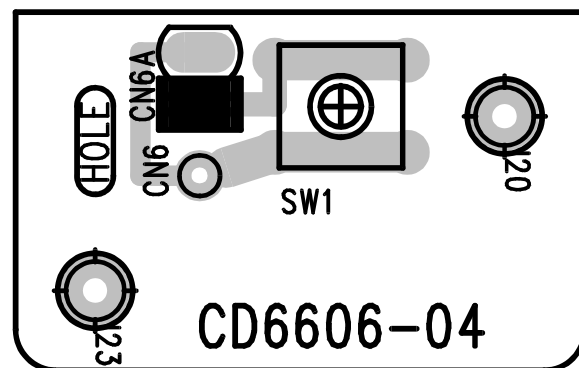

CONNECT PCB
CD6606-01-05

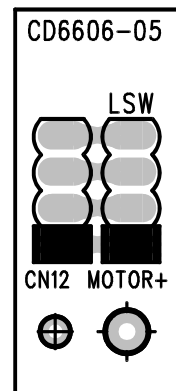

MOTOR & LEAF SW. CONNECT PCB
CD6606-01-06

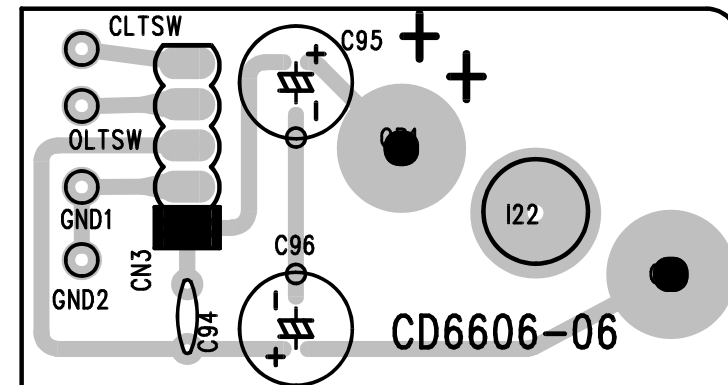

REMARKS:
PCB Part No.: 033-006606-600 of this model are assembled and aligned in FULL SET and are supplied in FULL SET for serving.

CASSETTE & CD PCB
CD6606-01-02

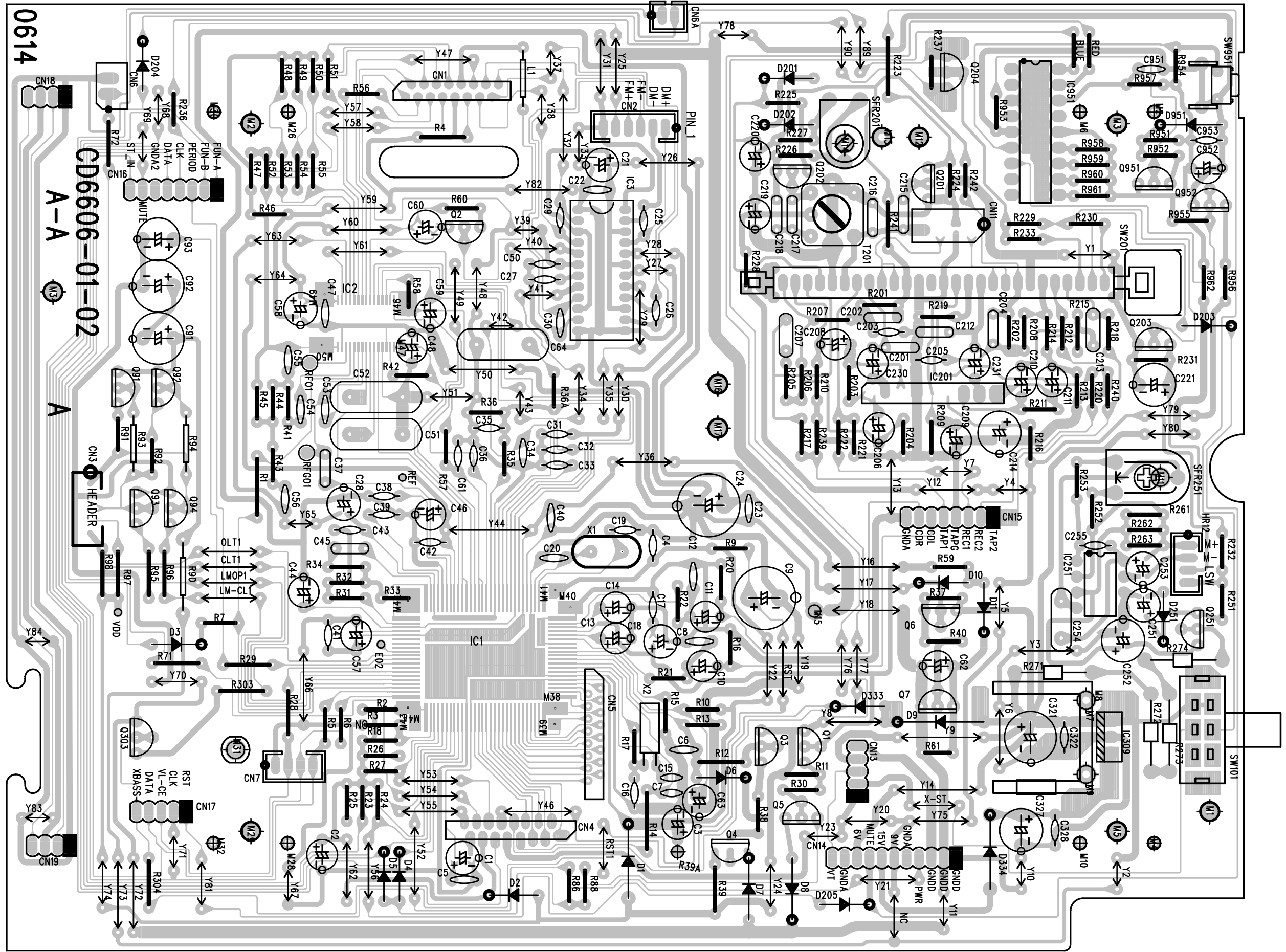

POWER PCB
CD6606-01-03

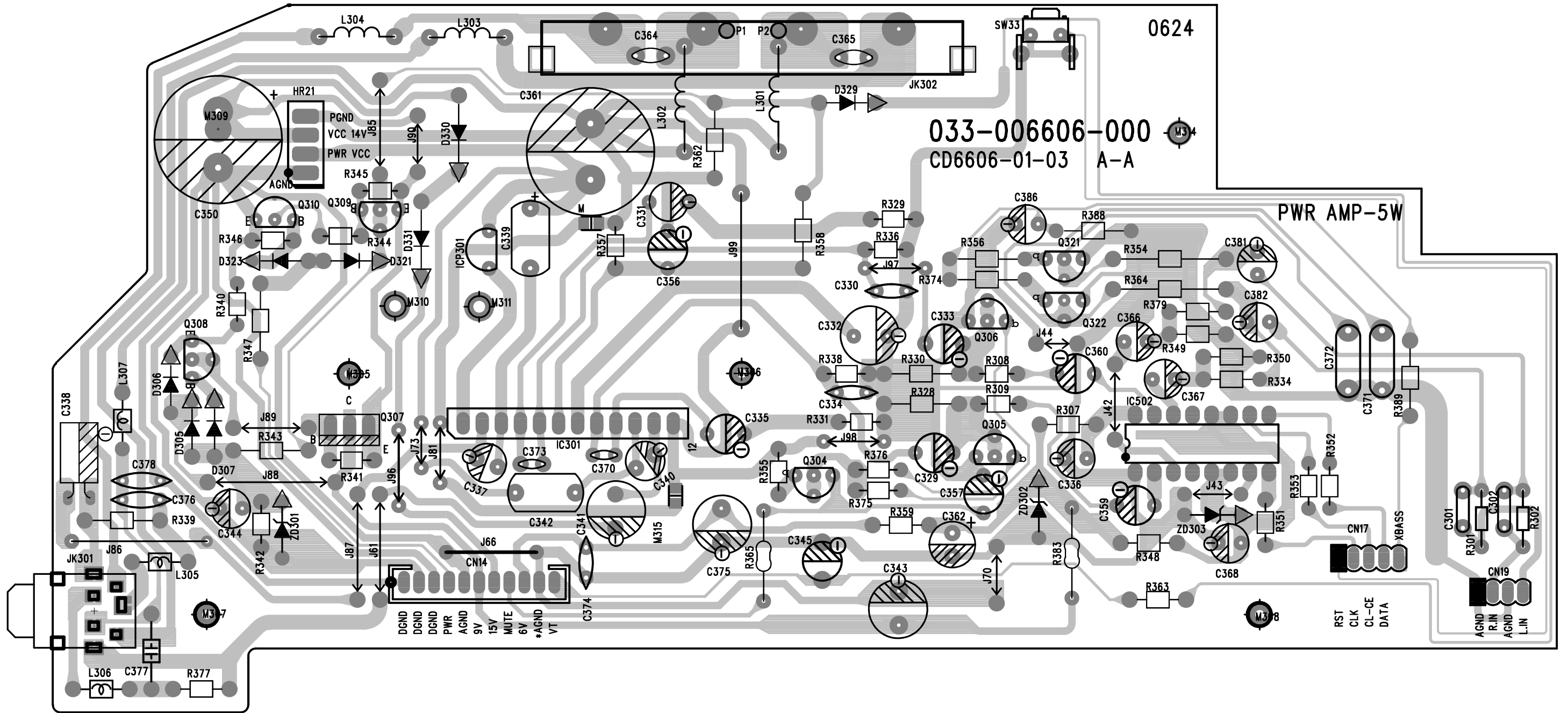

RECTIFIER PCB
CD6606-01-09

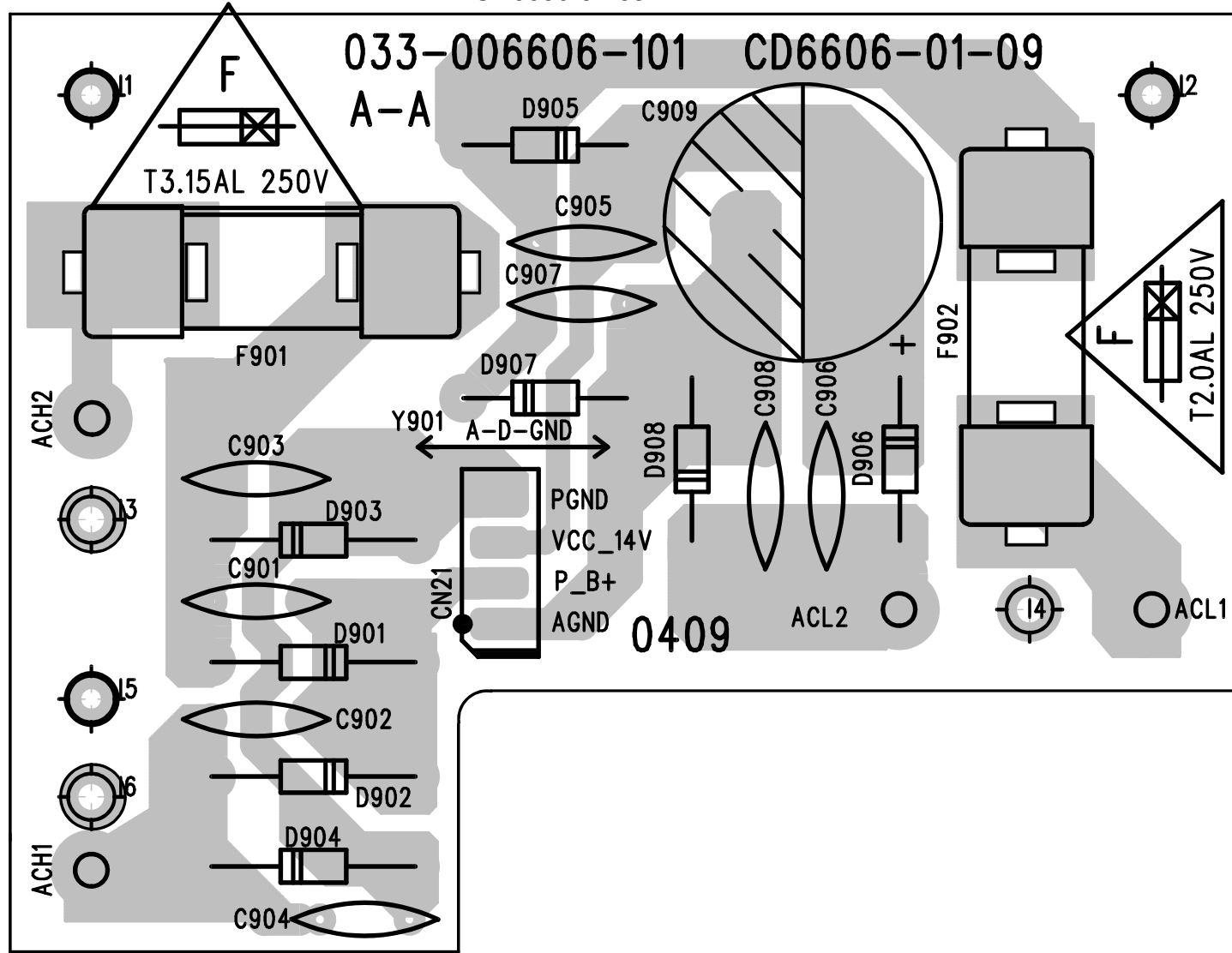

KEY & DISPLAY PCB
CD6606-01-08

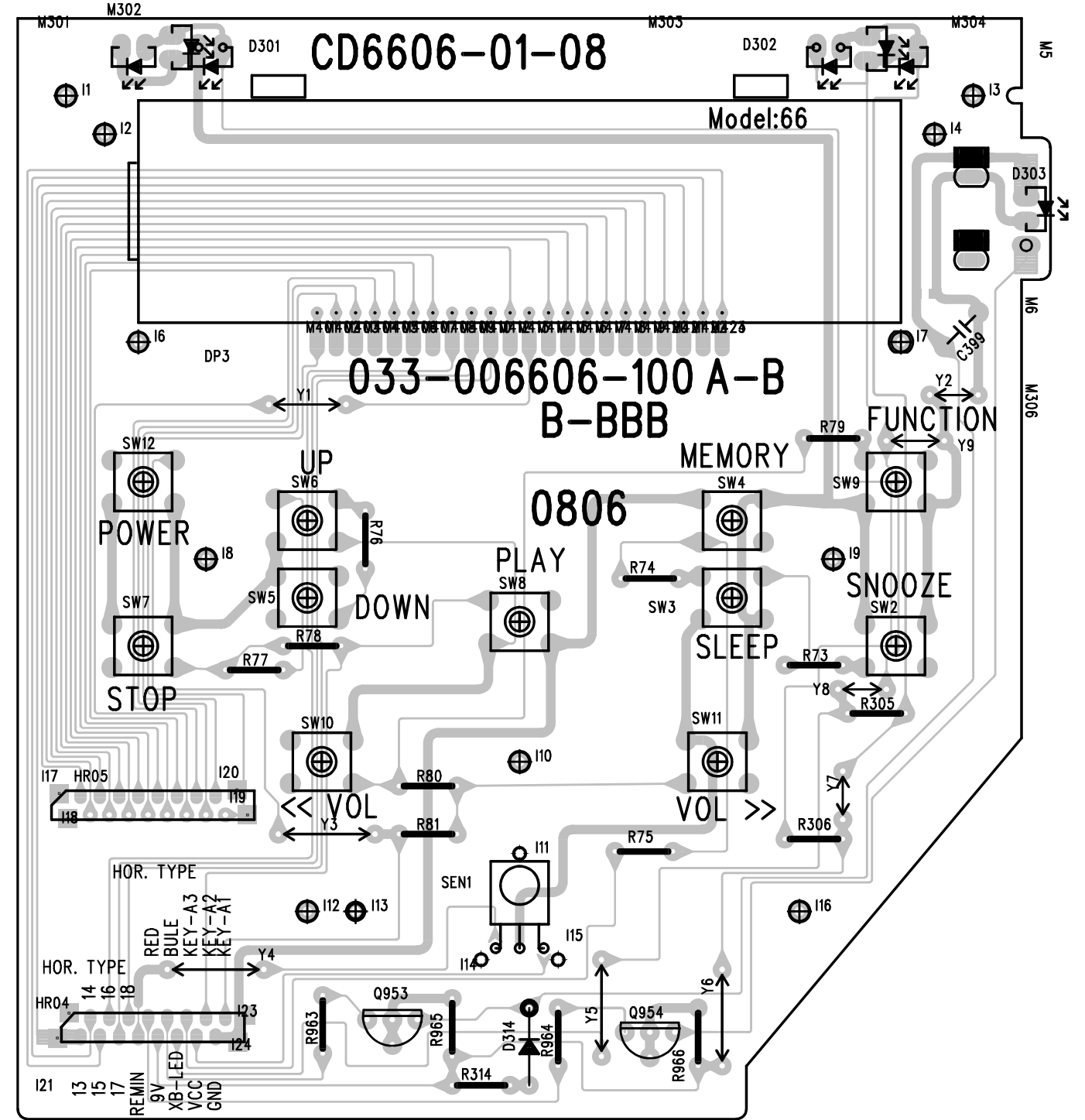

WIRING DIAGRAM

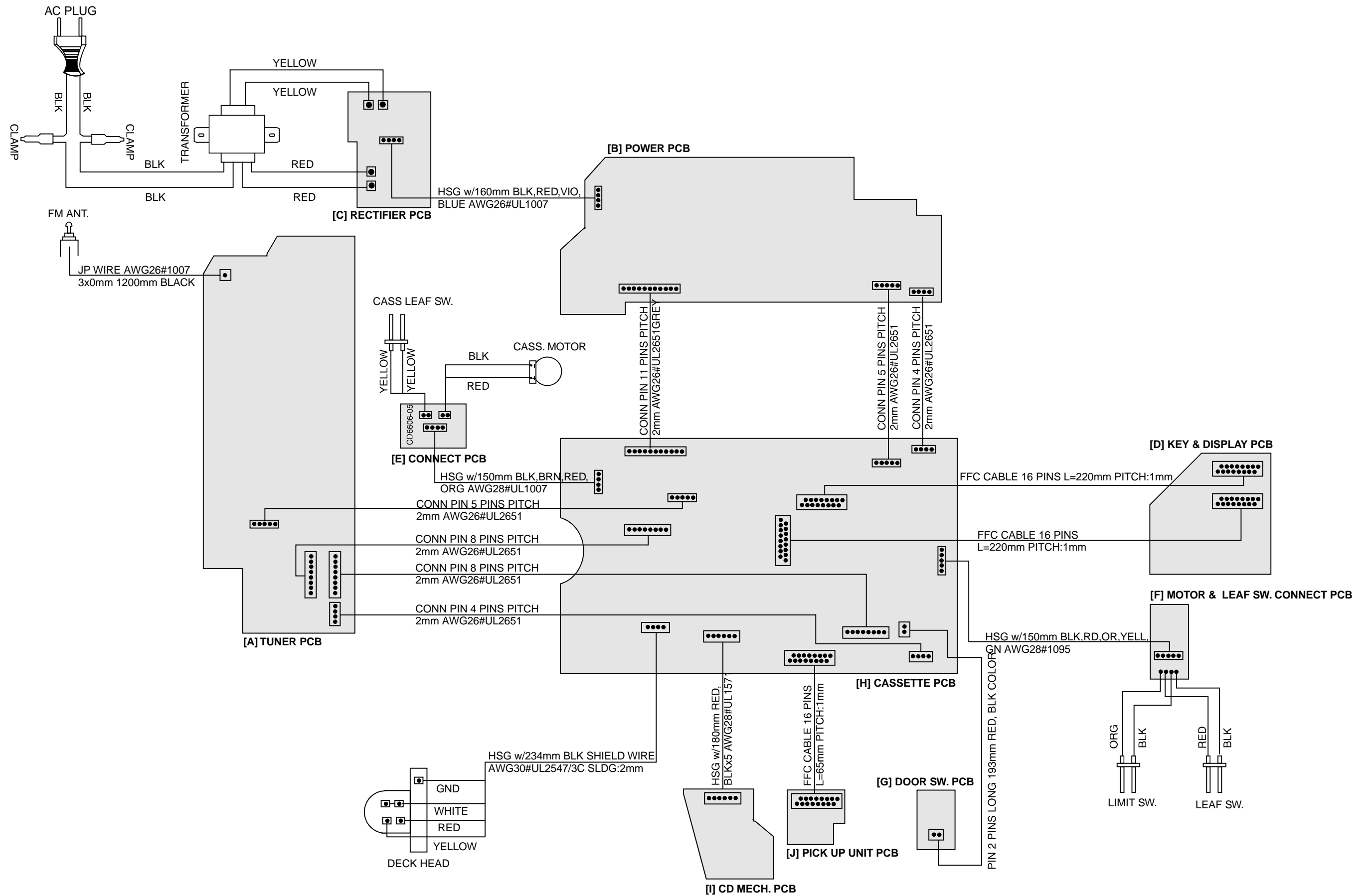

SCHEMATIC DIAGRAMS

TUNER & POWER SECTION

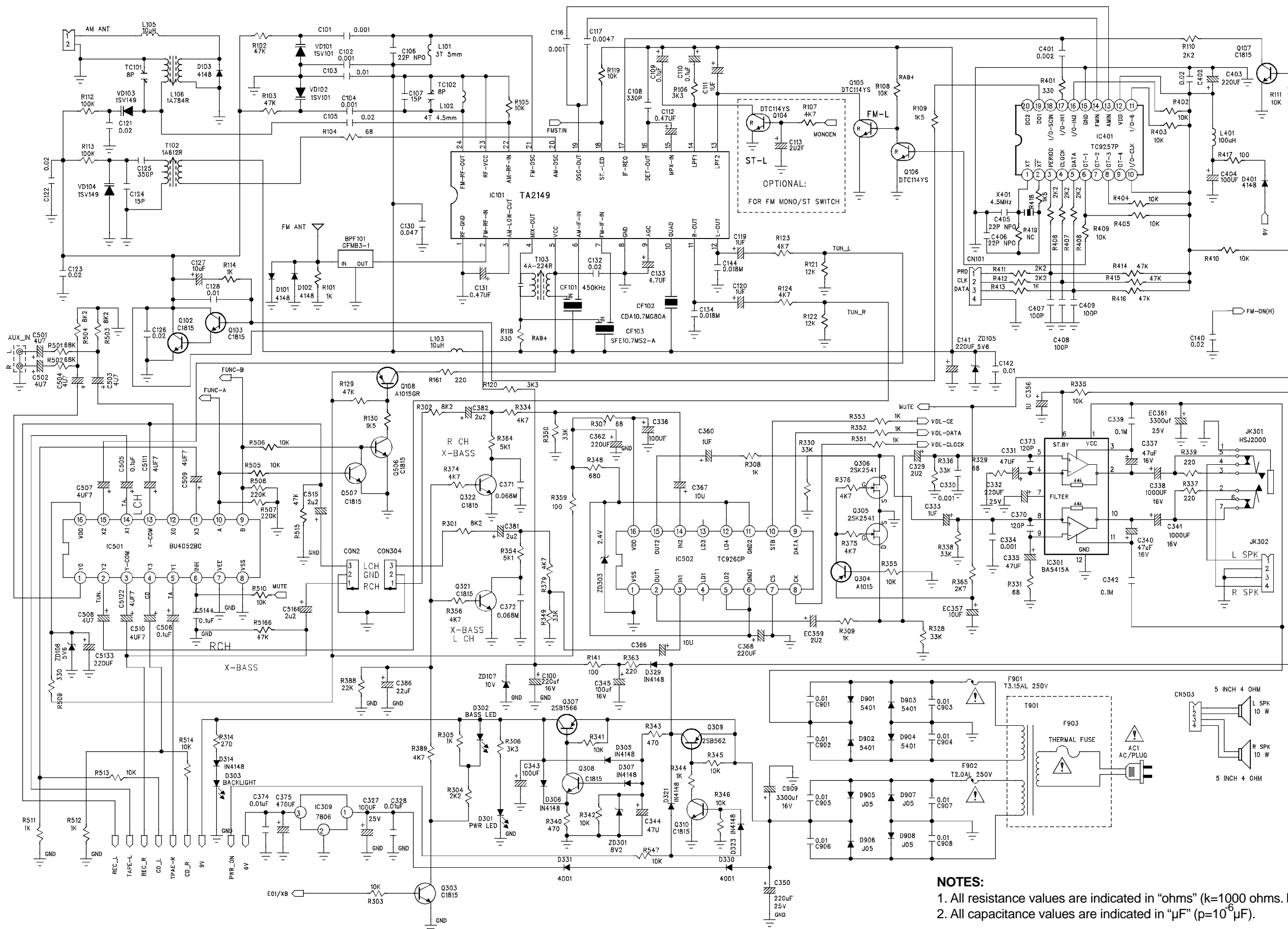

- NOTES:**
1. All resistance values are indicated in "ohms" (k=1000 ohms. M=1000 kohms).
 2. All capacitance values are indicated in "μF" (p=10⁻⁶ μF).

CASSETTE SECTION

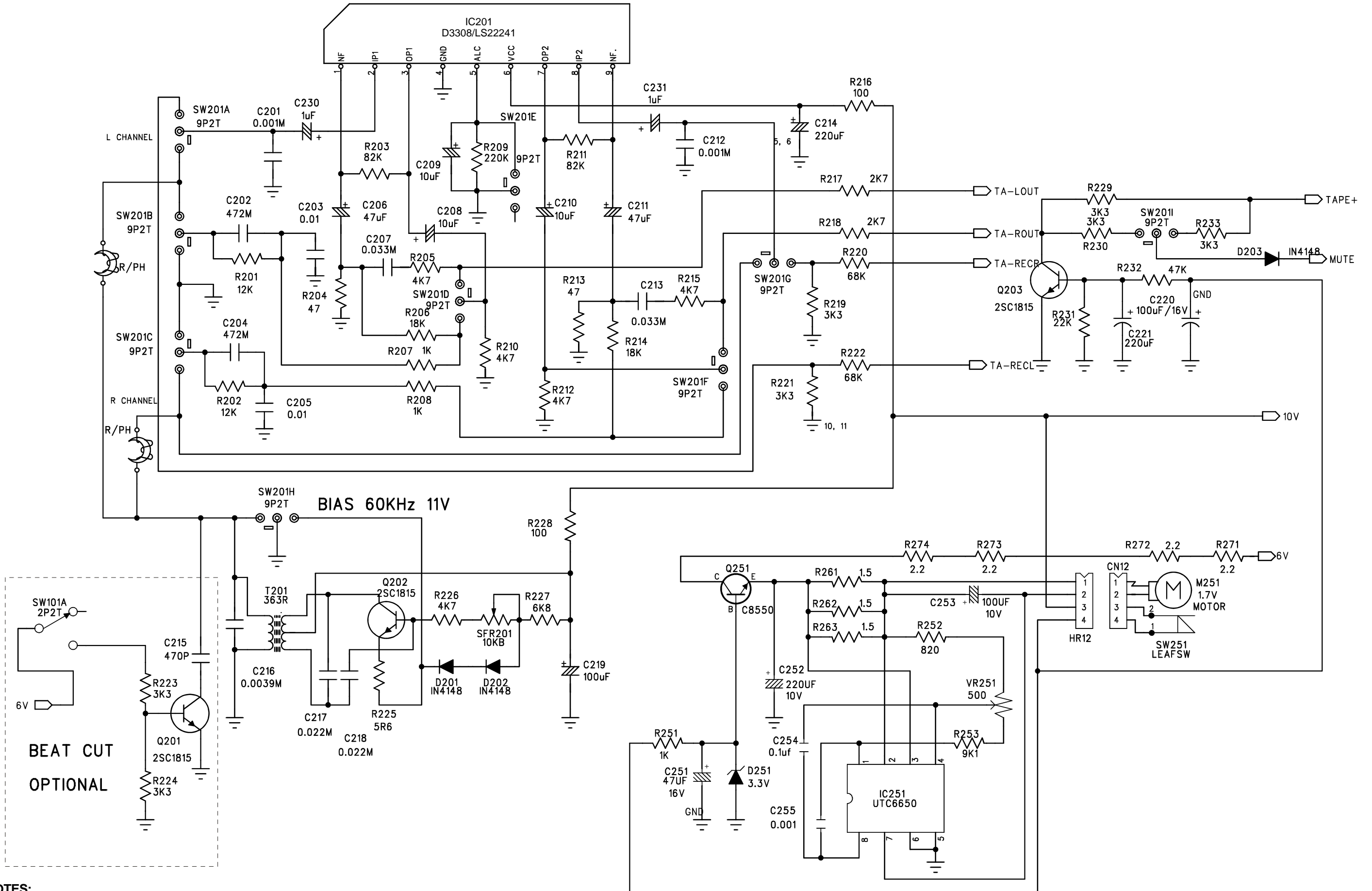

NOTES:

1. All resistance values are indicated in "ohms" (k=1000 ohms. M=1000 kohms).
2. All capacitance values are indicated in "µF" (p=10⁻⁶µF).

CD & DISPLAY SECTION

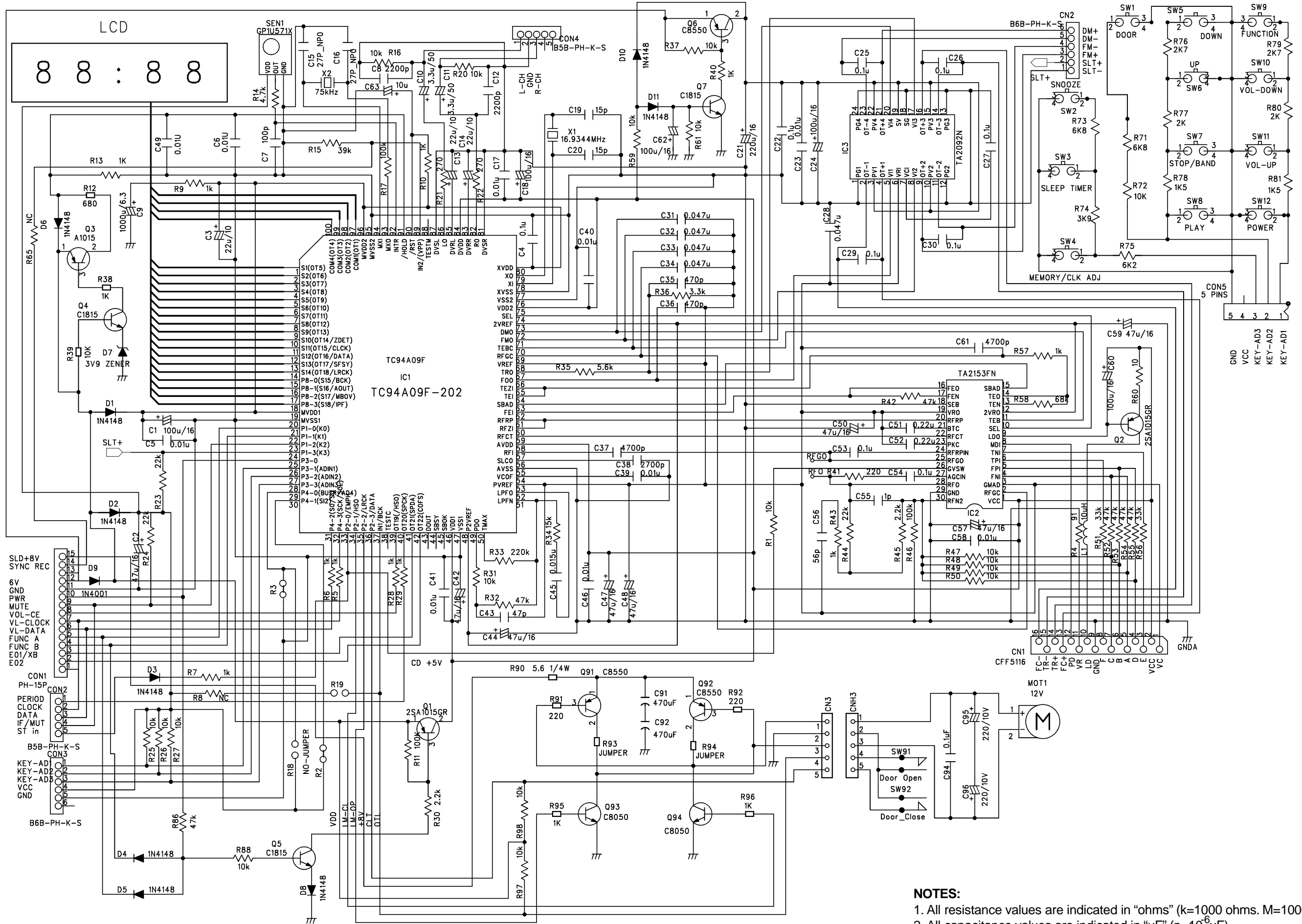

NOTES:

1. All resistance values are indicated in "ohms" (k=1000 ohms, M=1000 kohms).
2. All capacitance values are indicated in "µF" (p=10⁻⁶µF).

ALIGNMENT SET-UP PROCEDURES

TUNER SECTION

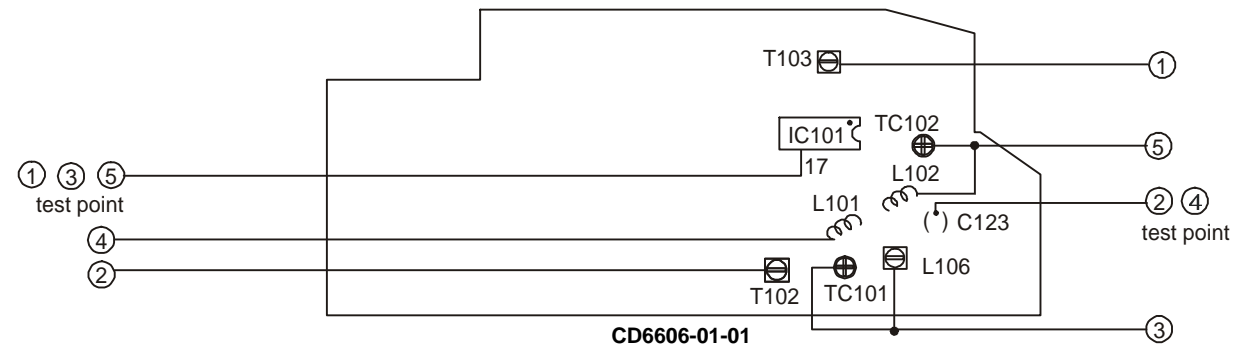

1. AM IF Adjustment
Test point: IC101 (TA2149BN) 17 PIN
Adjustment location: T103
T103 ----- 450kHz
2. AM Frequency Range Adjustment
Test point: C123
Adjustment location: T102
Set tuner frequency to be 522kHz.
Adjust T102 so that voltage of test point is $1.7 \pm 0.05V$.
Change tuner frequency to be 1620kHz, the voltage of test point should be less than 9.5V.
3. AM Tracking Adjustment
Test point: IC101 (TA2149BN) 17 PIN
Adjustment location: L106, TC101
L106 ----- 603kHz waveform max.
TC101 ----- 1404kHz waveform max.
4. FM Frequency Range Adjustment
Test point: C123
Adjustment location: L101
Set tuner frequency to be 87.5MHz.
Adjust L101 so that voltage of test point is $2.5 \pm 0.05V$.
Change tuner frequency to be 108MHz, the voltage of test point should be less than 9.5V.
5. FM Tracking Adjustment
Test point: IC101 (TA2149BN) 17 PIN
Adjustment location: L102, TC102
L102 ----- 90MHz waveform max.
TC102 ----- 106MHz waveform max.

CASSETTE SECTION

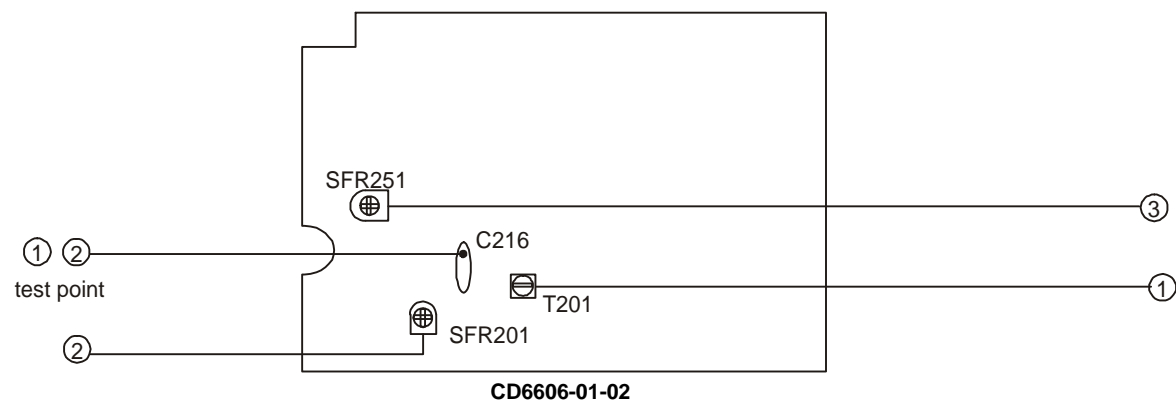

1. Bias Frequency Adjustment
Test point: C216
Adjustment location: T201
T201 ----- $60kHz \pm 1kHz$
2. Bias Level Adjustment
Test point: C216
Adjustment location: SFR201
SFR201 ----- $13V \pm 1V$
3. Tape Speed Adjustment
Test point: headphone jack
Adjustment location: SFR251
SFR251 ----- $3000Hz \pm 90Hz$

EQUIPMENT CONNECTION DIAGRAMS

AM SECTION

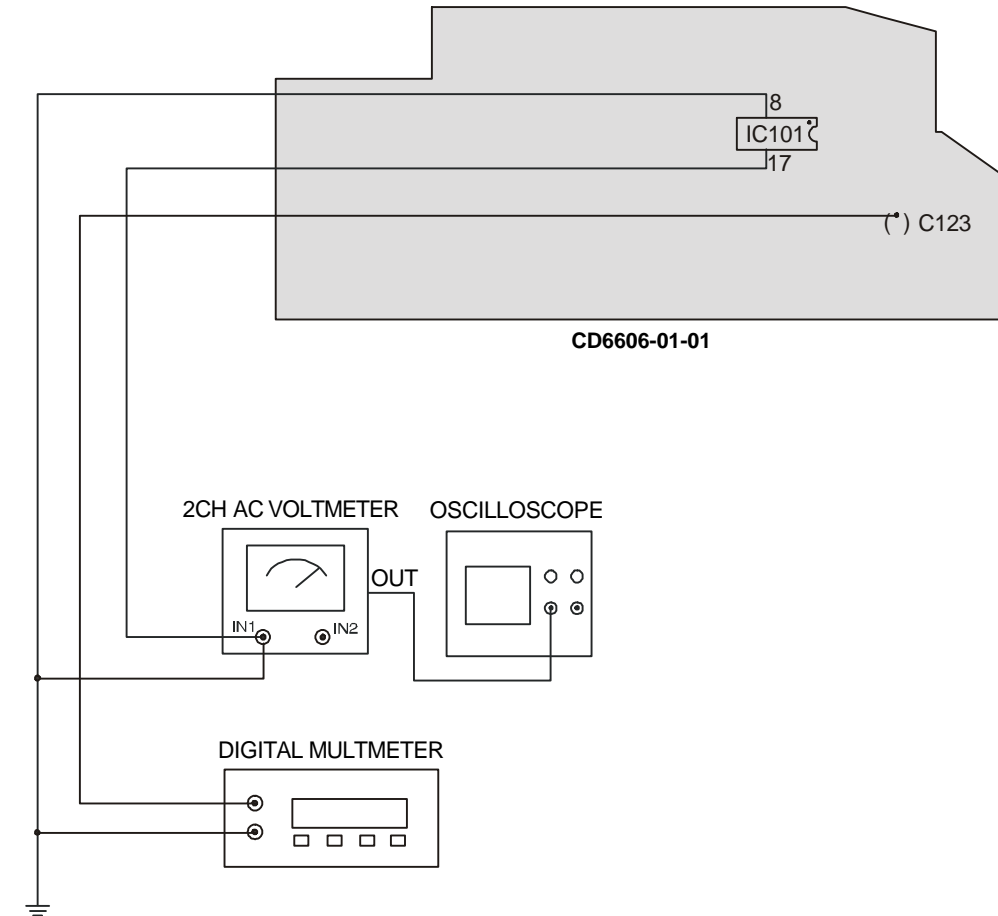

CASSETTE SECTION

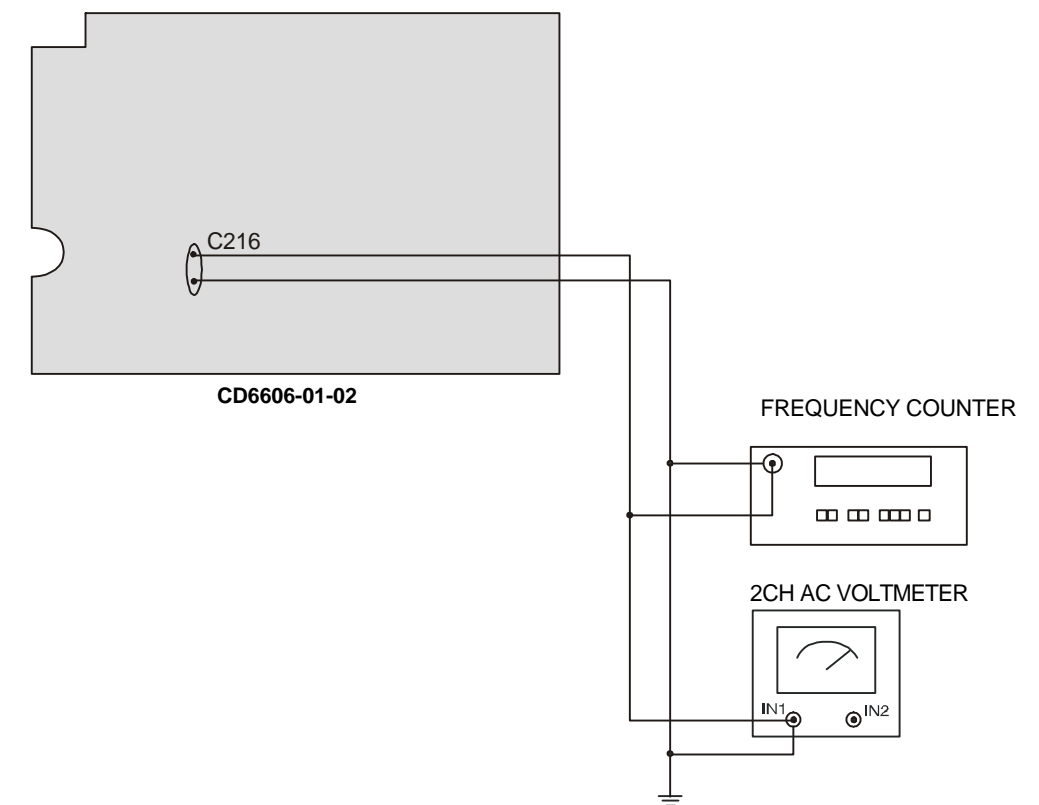

FM SECTION

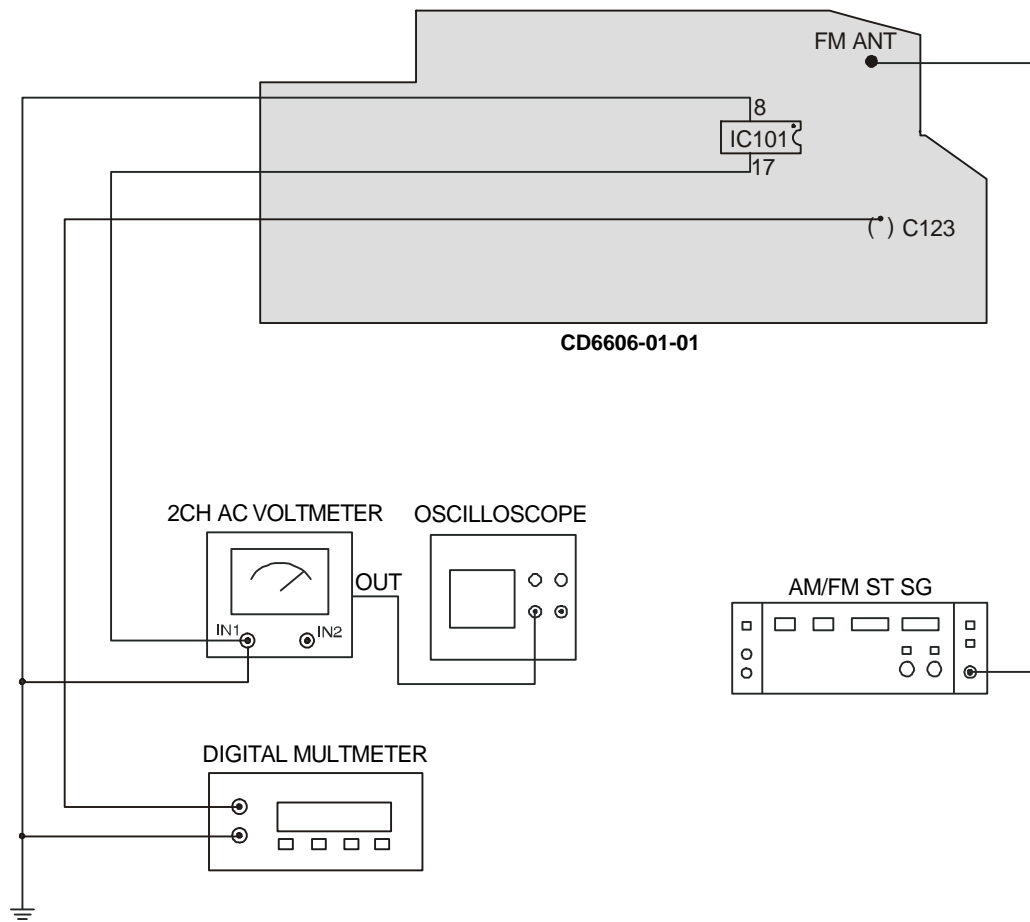

VOLTAGE CHART

THE MEASURED VALUE IS DC VOLTAGE

UNIT: V

TUNER SECTION

TEST CONDITION: SET AM/FM TUNER ONE FREQUENCY

IC101 (TA2149BN)

PIN'S NUMBER	1	2	3	4	5	6	7	8
AM	0	0	1.09	5.47	5.50	4.82	5.50	0
FM	0	0.80	0.21	4.83	4.99	4.45	5.02	0
PIN'S NUMBER	9	10	11	12	13	14	15	16
AM	0.28	4.92	1.24	1.26	0	0	0.71	1.11
FM	0	4.20	1.23	1.25	4.09	0	0.71	1.03
PIN'S NUMBER	17	18	19	20	21	22	23	24
AM	0.94	3.57	3.94	5.50	5.50	5.49	5.50	5.50
FM	0.95	3.29	3.43	4.99	4.99	4.97	4.99	5.01

IC401 (TC9257P)

PIN'S NUMBER	1	2	3	4	5	6	7	8	9	10
FM	2.11	2.26	4.76	4.76	4.76	3.22	0	0	0	4.57
PIN'S NUMBER	11	12	13	14	15	16	17	18	19	20
FM	4.57	4.58	0	2.34	0	4.57	2.26	0	1.07	0.27

TRANSISTOR	Q102(C1815)			Q103(C1815)		
	E	C	B	E	C	B
FM	0	8.39	0.60	0.60	8.39	1.07

POWER AMP. SECTION

TEST CONDITION: FM ON OR CD PLAY

IC501 (BU4052BC)

PIN'S NUMBER	1	2	3	4	5	6	7	8
TUNER	0.11	0.11	0.11	0.10	0	0.12	0	0
CASSETTE	0.10	0.10	0.10	0.10	0	0.12	0	0
CD	0.12	0.12	0.11	0.10	0	0.16	0	0
PIN'S NUMBER	9	10	11	12	13	14	15	16
TUNER	4.65	0	0	0	0	0	0	5.62
CASSETTE	0	4.22	0	0	0	0	0	5.62
CD	4.45	4.47	0	0	0	0	0	5.62

IC309 (L7806CV)

PIN'S NUMBER	1	2	3
FM	12.00	0	6.00

TRANSISTOR	Q506(C1815)			Q507(C1815)			Q108(8550)		
	E	C	B	E	C	B	E	C	B
FM	0	0	0.70	0	0.70	0	8.29	8.27	7.55
TRANSISTOR	Q309(2SB562)			Q310(C1815)					
	E	C	B	E	C	B			
FM	13.37	13.37	12.52	0	0	0.69			

TRANSISTOR	Q307(2SB1566)			Q308(C1815)		
	E	C	B	E	C	B
CD	13.00	8.31	12.32	7.59	12.24	8.14

VOLTAGE CHART - CONTINUED

IC502 (TC9260P)

PIN'S NUMBER	1	2	3	4	5	6	7	8
FM	0	2.43	2.43	2.43	2.43	2.43	0	4.76
PIN'S NUMBER	9	10	11	12	13	14	15	16
FM	4.76	0	2.43	2.43	2.43	2.43	2.43	5.59

IC301 (BA5415A)

PIN'S NUMBER	1	2	3	4	5	6
FM	16.51	8.50	14.21	0.61	0	9.19
PIN'S NUMBER	7	8	9	10	11	12
FM	15.02	0	0.61	14.15	8.39	0

CD SECTION

TEST CONDITION: CD PLAY

IC1 (TC94A09F-202)

PIN'S NUMBER	1	2	3	4	5	6	7	8	9	10
CD PLAY	/	/	/	/	/	/	/	/	/	/
PIN'S NUMBER	11	12	13	14	15	16	17	18	19	20
CD PLAY	/	/	/	/	/	/	/	2.30	4.59	0
PIN'S NUMBER	21	22	23	24	25	26	27	28	29	30
CD PLAY	4.47	4.45	0.15	4.64	4.48	4.65	4.65	4.65	4.66	4.66
PIN'S NUMBER	31	32	33	34	35	36	37	38	39	40
CD PLAY	4.60	4.59	4.58	0	0	0	5.10	0	0	4.59
PIN'S NUMBER	41	42	43	44	45	46	47	48	49	50
CD PLAY	0	0	5.17	0	5.17	5.17	0	4.22	2.12	2.07
PIN'S NUMBER	51	52	53	54	55	56	57	58	59	60
CD PLAY	2.12	2.00	2.12	1.67	0	2.11	2.12	5.17	2.60	2.61
PIN'S NUMBER	61	62	63	64	65	66	67	68	69	70
CD PLAY	2.61	1.99	1.98	2.15	2.13	2.23	2.13	2.12	2.26	2.03
PIN'S NUMBER	71	72	73	74	75	76	77	78	79	80
CD PLAY	2.12	2.22	4.22	2.59	5.17	0	0	2.12	2.17	4.59
PIN'S NUMBER	81	82	83	84	85	86	87	88	89	90
CD PLAY	0	2.72	2.59	5.18	2.59	2.72	0	0	0	4.59
PIN'S NUMBER	91	92	93	94	95	96	97	98	99	100
CD PLAY	3.12	4.64	2.34	1.65	0	4.59	2.29	2.30	2.30	2.31

IC2 (TA2153FN)

PIN'S NUMBER	1	2	3	4	5	6	7	8	9	10
CD PLAY	5.17	2.24	2.12	2.18	2.19	2.15	2.15	0.20	4.08	2.59
PIN'S NUMBER	11	12	13	14	15	16	17	18	19	20
CD PLAY	2.11	4.22	2.12	2.16	1.99	2.02	2.12	0	2.12	2.62
PIN'S NUMBER	21	22	23	24	25	26	27	28	29	30
CD PLAY	3.32	2.60	1.90	2.12	2.08	4.08	2.11	1.77	0	2.12

VOLTAGE CHART - CONTINUED

IC3 (TA2092N)

PIN'S NUMBER	1	2	3	4	5	6	7	8
CD PLAY	0	2.85	5.93	2.46	2.05	2.12	2.65	2.09
PIN'S NUMBER	9	10	11	12	13	14	15	16
CD PLAY	2.54	5.94	2.70	0	0	2.65	5.94	2.65
PIN'S NUMBER	17	18	19	20	21	22	23	24
CD PLAY	2.12	0	5.94	2.24	2.99	5.94	2.34	0

TRANSISTOR	Q91(C8550)			Q92(C8550)		
	E	C	B	E	C	B
DOOR/OPEN	5.65	0	5.23	5.75	5.71	4.66
DOOR/CLOSE	5.47	5.47	4.66	5.47	0	5.45
TRANSISTOR	Q93(C8050)			Q94(C8050)		
	E	C	B	E	C	B
DOOR/OPEN	0	0	0.77	0	5.74	0
DOOR/CLOSE	0	5.44	0	0	0	0.79

TRANSISTOR	Q1(2SA1015GR)			Q5(C1815)		
	E	C	B	E	C	B
CD PLAY	5.25	5.18	4.49	0.67	0.76	1.34

CASSETTE SECTION

TEST CONDITION: TAPE PLAY OR REC.

IC201 (LS22241/D3308)

PIN'S NUMBER	1	2	3	4	5	6	7	8	9
TAPE PLAY	1.79	0	1.80	0	0	7.98	1.81	0	1.80

IC251 (UTC6650)

PIN'S NUMBER	1	2	3	4	5	6	7	8
TAPE PLAY	1.24	2.51	2.57	2.29	0	0	0.71	0.75

TRANSISTOR	Q201(2SC1815)		
	E	C	B
REC.	0	0	0.72
TRANSISTOR	Q202(2SC1815)		
	E	C	B
REC.	7.83	8.29	8.28

TRANSISTOR	Q251(C8550)		
	E	C	B
TAPE PLAY	2.57	5.15	3.23

IC LEAD IDENTIFICATION AND INTERNAL DIAGRAMS

IC501 BU452BC

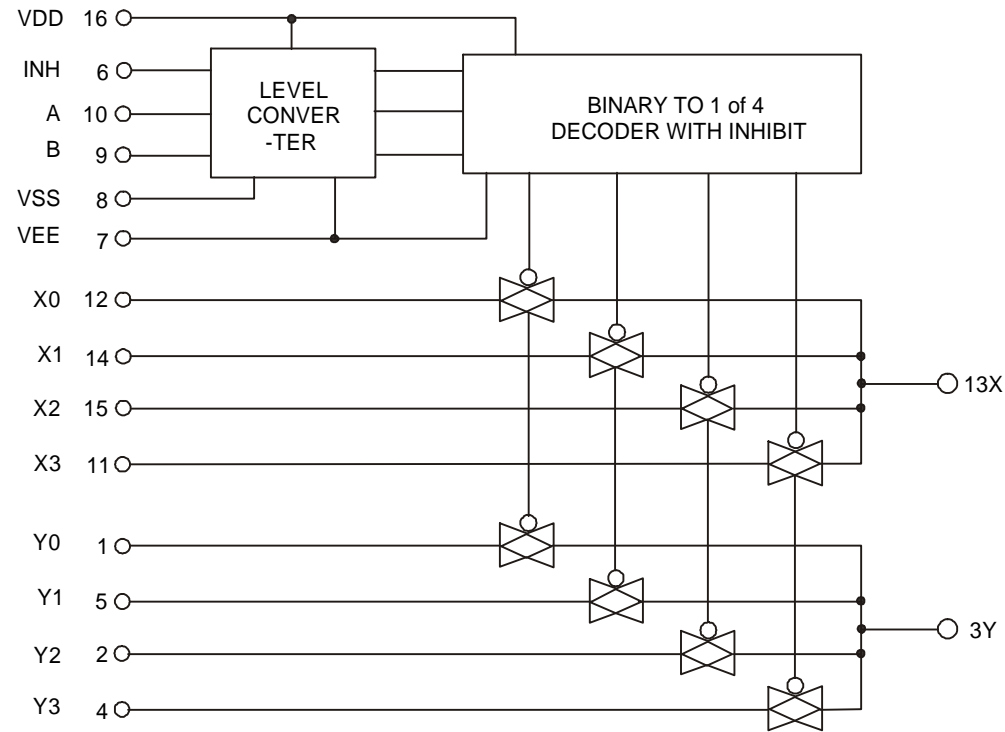

IC3 TA2092N

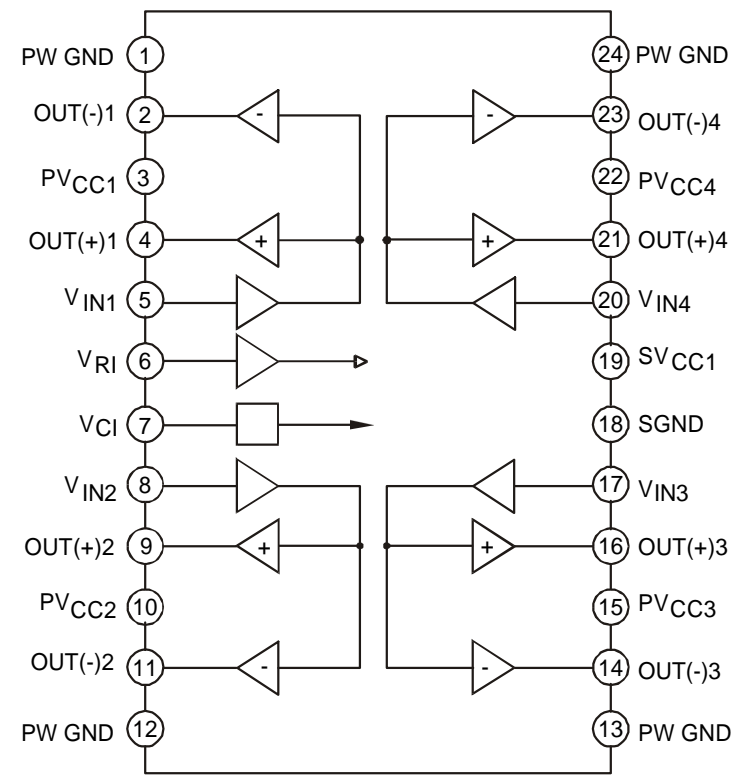

IC309 L7806CV

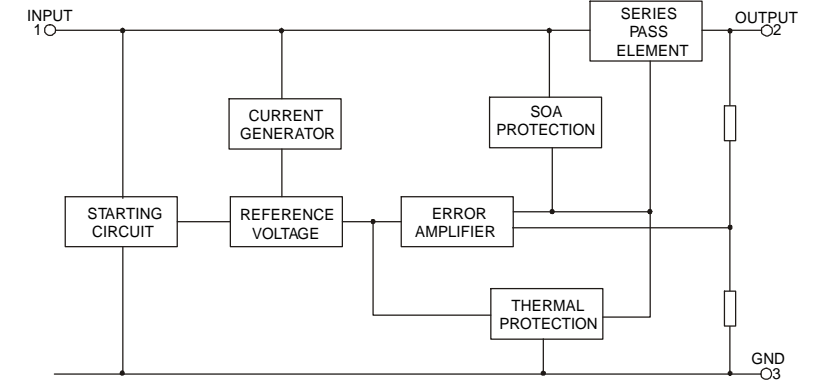

IC251 UTC6650

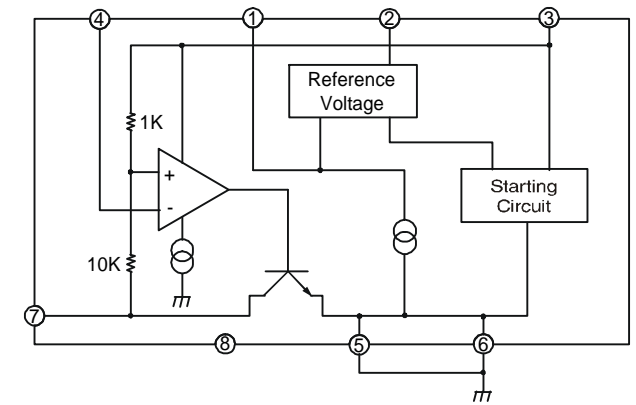

IC401 TC9257P

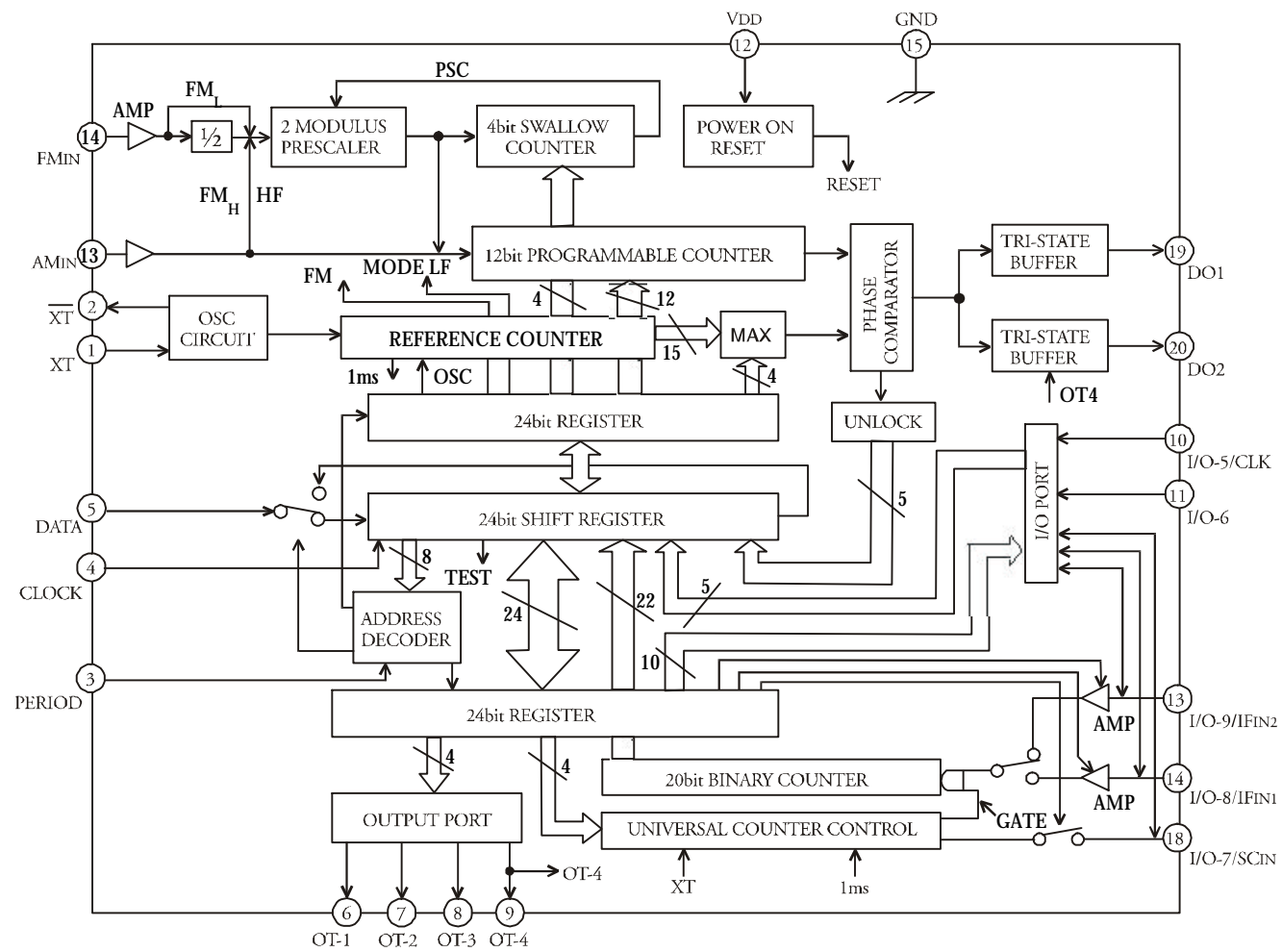

IC101 TA2149BN

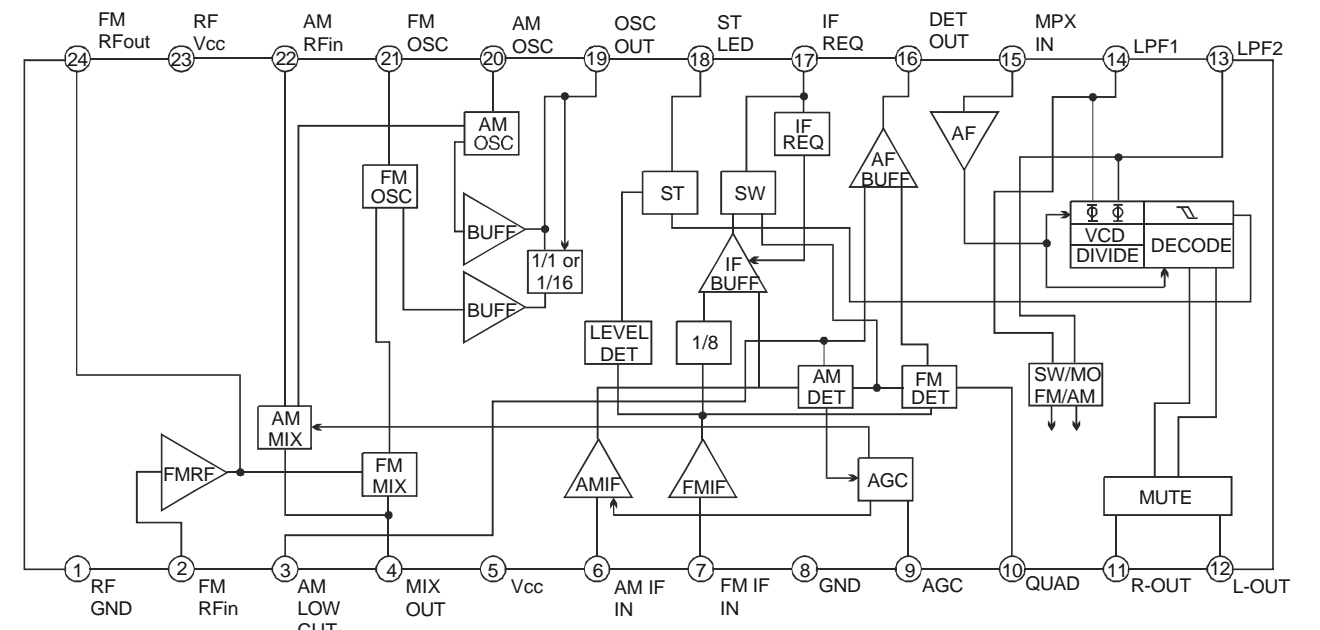

IC301 BA5415A

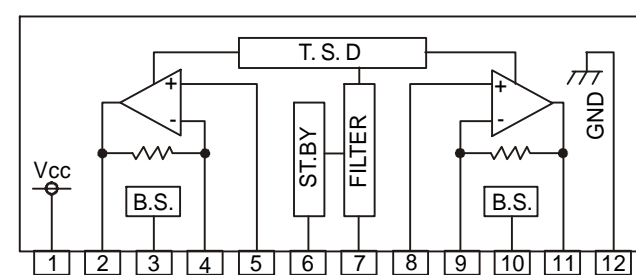

IC201 LS22241/D3308

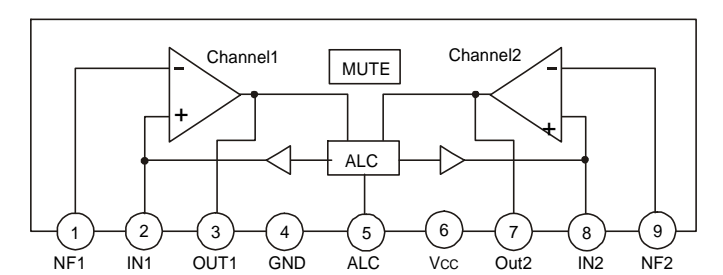

IC2 TA2153FN

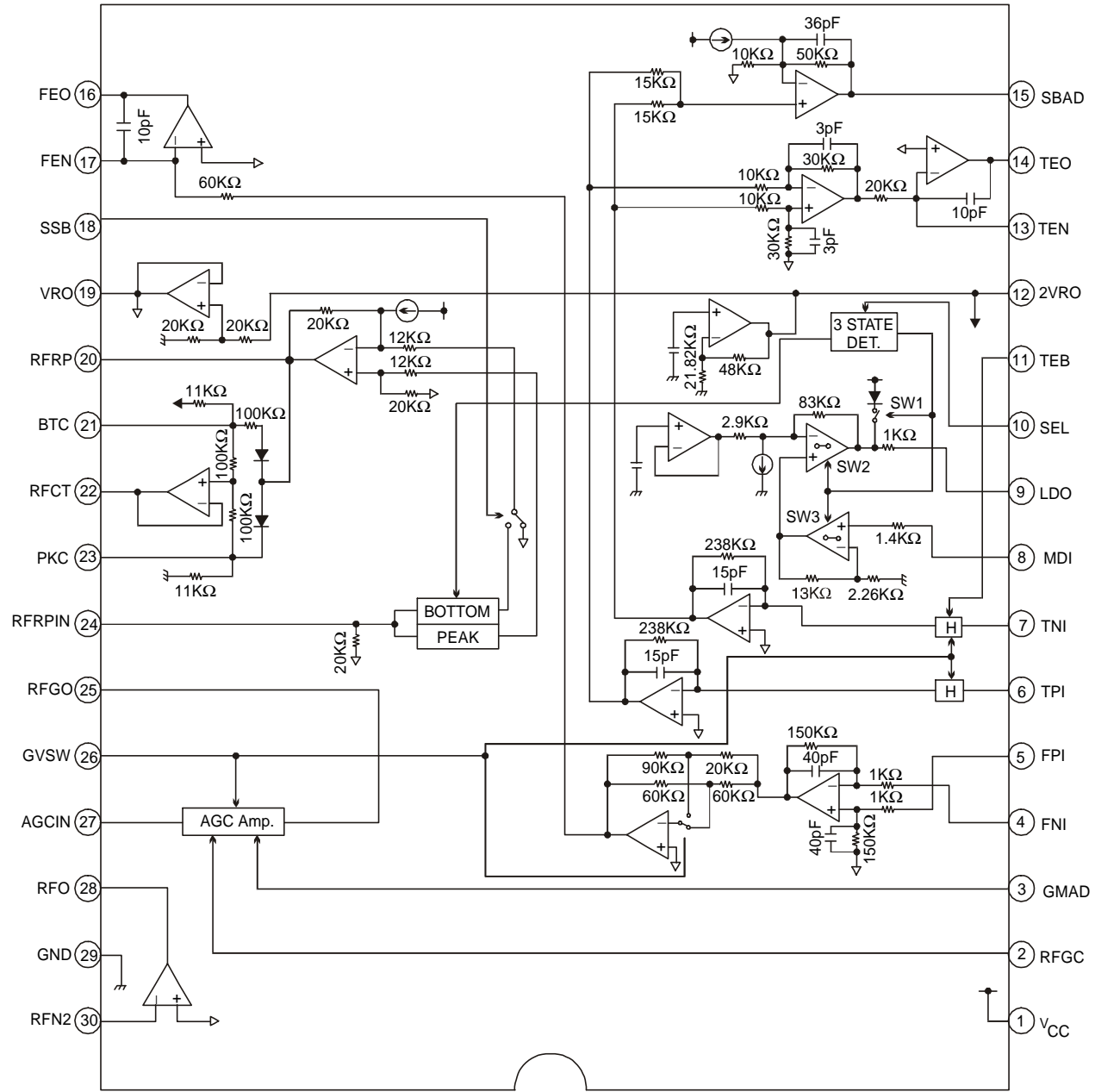

IC502 TC9260P

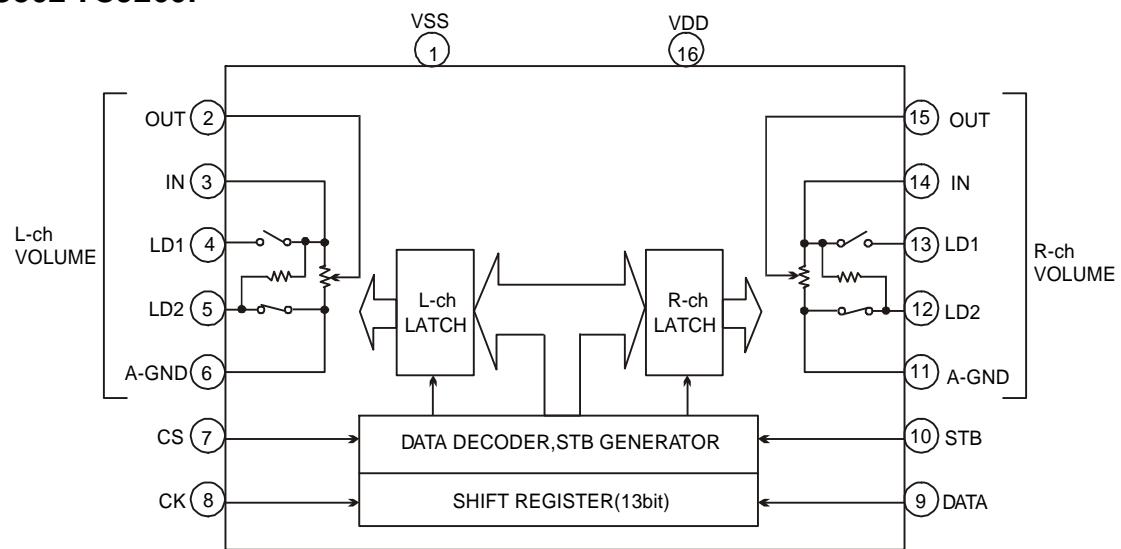

IC1 TC94A09F-202

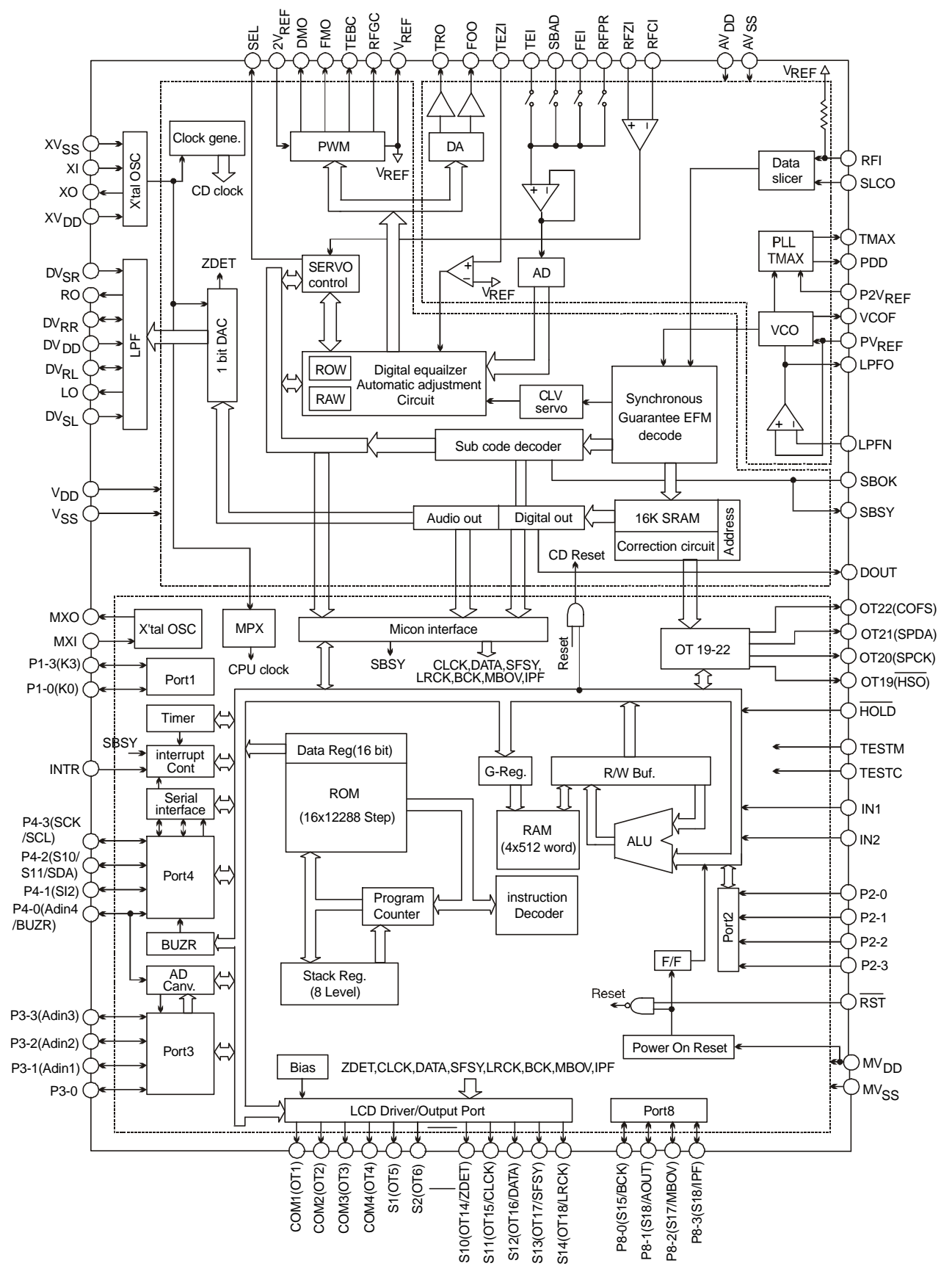

TUNER & POWER AMP. SECTION

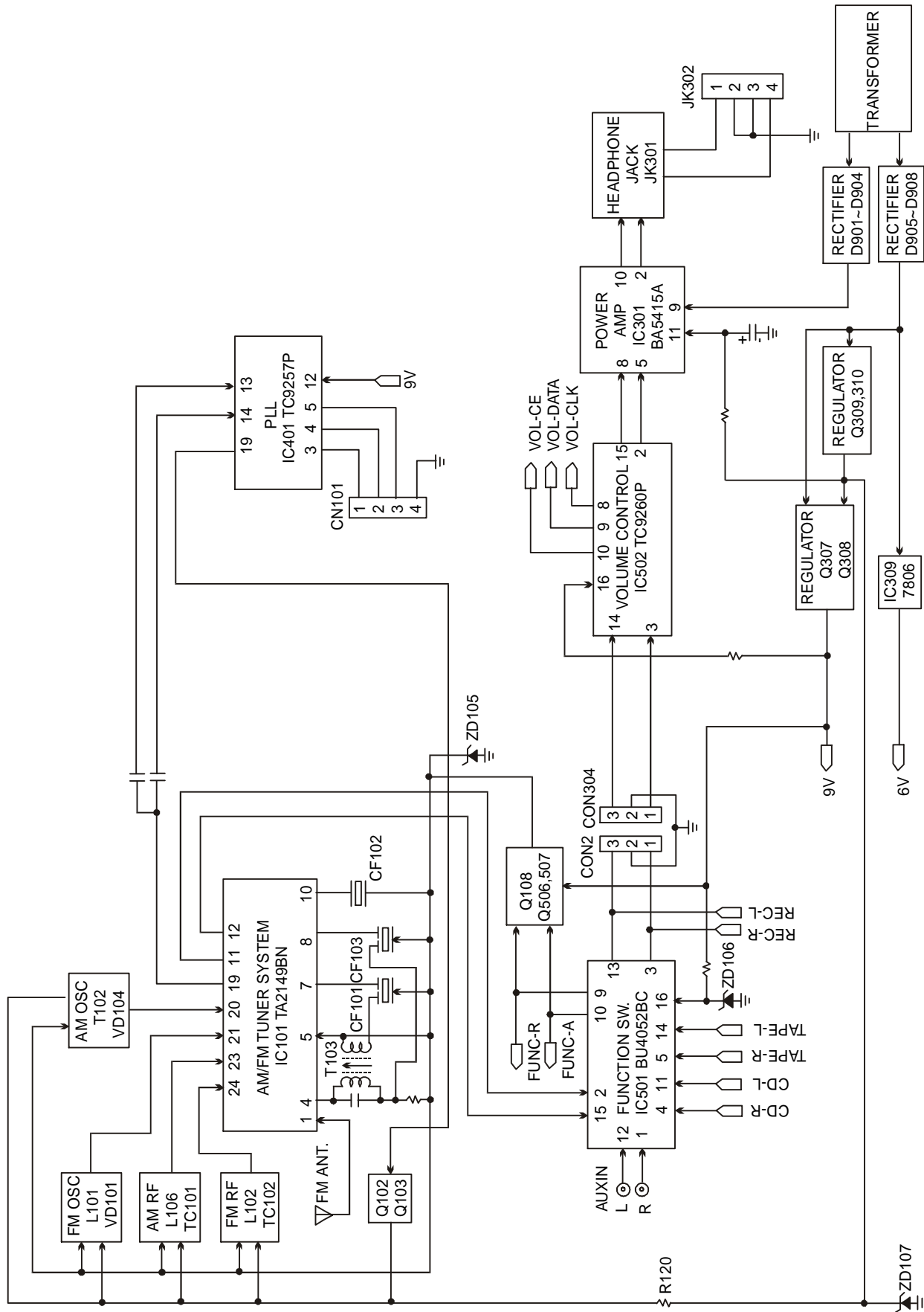

BLOCK DIAGRAMS

CD & DISPLAY SECTION

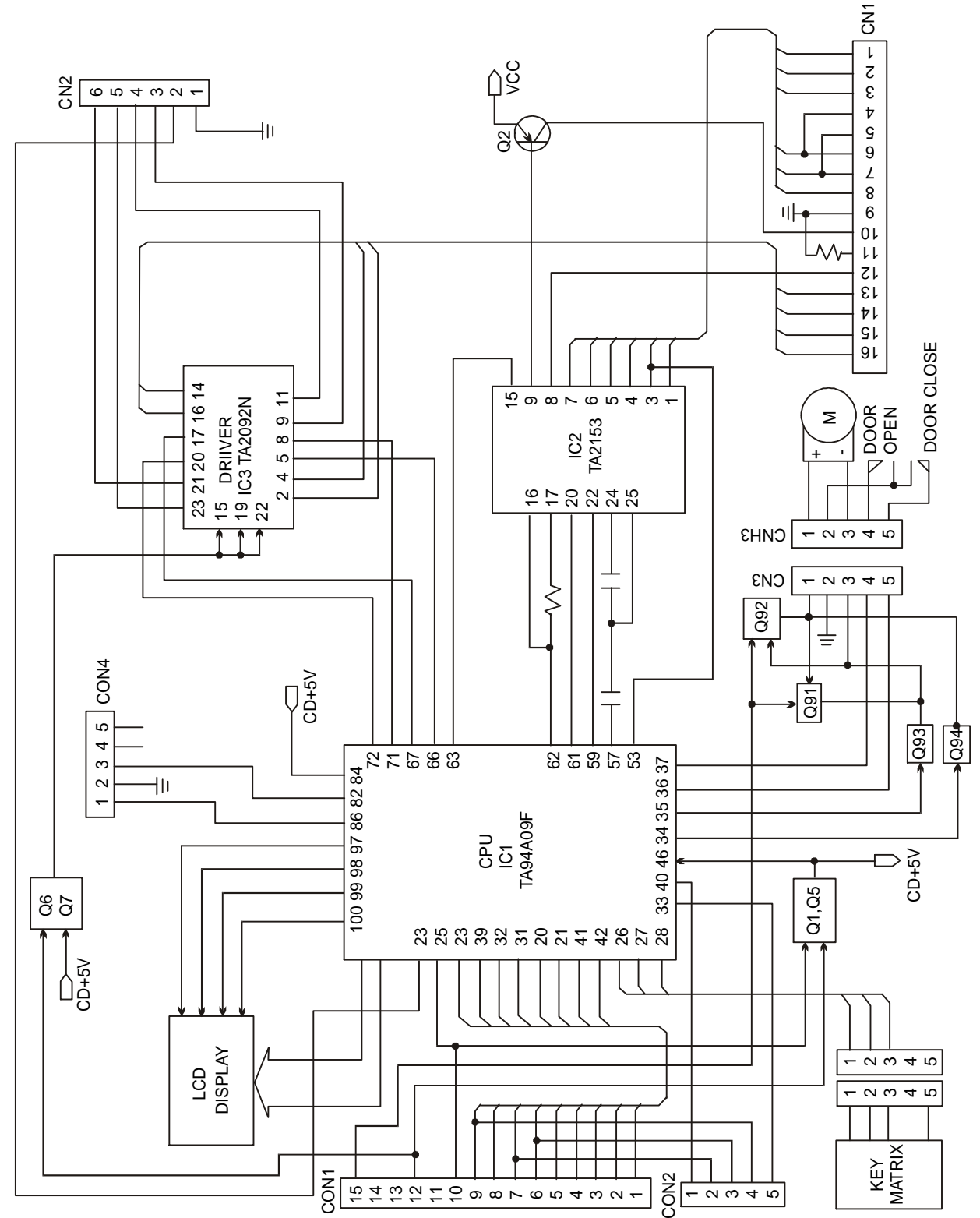

CASSETTE SECTION

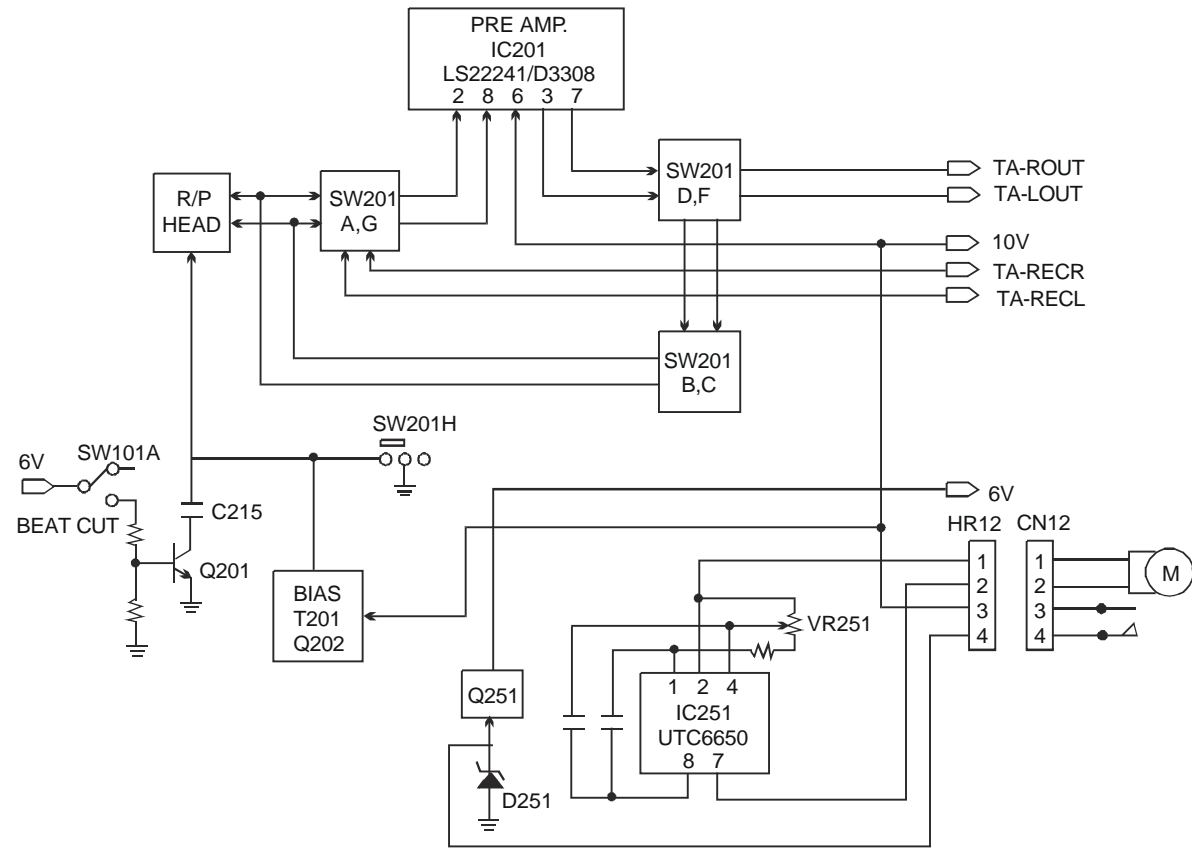

EXPLODED DRAWING PARTS LIST

Ref. No.	Description	Mfr's Part No.	Qty.
MAIN UNIT			
1	CD DOOR LENS, MOLD TRANS.BLUE(A-30188A) (SAN), CAV:1, w/PNT	500-660806-xxx	1
2	REMOTE LENS, MOLD TRANS.BLUE(A-30188A) (SAN) CAV:1	500-660826-000	1
3	CD DOOR, MOLDED COLOR (ABS) CAV:1, w/PNT, HS(AM89024AL)	500-660803-xxx	1
4	PLAY/PAUSE KNOB, MOLD NATURAL (ABS) CAV:1, w/CHROME-PLATED	510-660623-001	1
5	SKIP FORWARD KNOB, MOLD NATURAL (ABS) CAV:1, w/CHROME-PLATED	510-660631-001	1
6	VOLUME KNOB, MOLD NATURAL (ABS) CAV:1, w/CHROME-PLATED	510-660610-001	1
7	KNOB BRACKET "D", MOLDED BLACK, CAV.1 (ABS)	505-660838-000	1
8	SKIP BACKWARD KNOB, MOLD NATURAL (ABS) CAV:1, w/CHROME-PLATED	510-660632-001	1
9	STOP KNOB, MOLD NATURAL (ABS) CAV:1, w/CHROME-PLATED	510-660628-001	1
10	KNOB BRACKET "B", MOLDED BLACK, CAV.1 (ABS)	505-660836-000	1
11	POWER KNOB, MOLD NATURAL (ABS) CAV:1, w/CHROME-PLATED	510-660627-001	1
12	KNOB BRACKET "A", MOLDED BLACK, CAV.1 (ABS)	505-660835-000	1
13	KEY & DISPLAY PCB CD6606-01-08	033-006606-100	1
14	CD DOOR COVER, MOLD COOL GREY 9C (ABS) CAV:2	500-660265-000	1
15	RUBBER FOOT, 5x5x2mm (PORON)	700-660648-000	2
16	SENSOR HOLDER, MOLDED WHITE, CAV.1 (ABS)	505-660614-000	1
17	KNOB BRACKET "C", MOLDED BLACK, CAV.1 (ABS)	505-660837-000	1
18	SLEEP/TIMER KNOB, MOLD NATURAL (ABS) CAV:1, w/CHROME-PLATED	510-660615-001	1
19	SNOOZE KNOB, MOLD NATURAL (ABS) CAV:1, w/CHROME-PLATED	510-660630-001	1
20	FUNCTION KNOB, MOLD NATURAL (ABS) CAV:1, w/CHROME-PLATED	510-660629-001	1
21	MEMORY KNOB, MOLD NATURAL (ABS) CAV:1, w/CHROME-PLATED	510-660611-001	1
22	LCD-P-&D-80x25SM022P JT4-01600, 80x25x2.8mm, TRANSMISSIVE/POSITIVE	LCD1 112-001600-000	1
23	LCD DIFFUSER PAPER, T=0.1mm D207	650-660654-000	1
24	DIFFUSER LENS, MOLDED TRANSPARENT, CAV.2 (PMMA)	500-660616-000	1
25	LCD BRACKET, MOLDED WHITE, CAV.1 (ABS)	505-660618-000	1
26	CASS DOOR LENS, MOLDED COLOR (SAN) CAV:1, w/SPY & PNT	500-660807-xxx	1
27	CASS DOOR, MOLDED COLOR (ABS), CAV:1, w/SPY, H-S(AM89024AL)	500-660804-xxx	1
28	CASS DOOR SPRING, DIA:0.8mm (SUS WIRE)	561-660243-000	1
29	CASS DOOR FRAME, MOLD COOL GREY 9C (ABS) CAV:2	500-660605-000	1
30	FRONT COVER, MOLD COLOR (ABS) CAV:1, w/SPY	500-660219-xxx	1
31	FRONT PANEL, MOLD COLOR (HIPS) CAV:1, w/SPY, (w/o BEAT CUT)	500-660667-xxx	1
32	MOUNTING PLATE, T=0.8mm (EG STEEL)	650-078864-000	4
33	CASSDECK-SM-T-S03+&& TN-9ZR-219, w/o MOTOR,RP HEAD,E HEAD	150-000219-K00	1
34	CASS KNOB SET, MOLD COOL GREY 9C (ABS) CAV:2	510-139110-002	1
35	RECORDING PLATE, T=0.7mm STAINLESS STEEL	650-660652-000	1
36	TUNER PCB CD6606-01-01	033-006606-600	1
37	PIN JACK #HSP-212V-06 WHITE/RED	JK501 118-020212-001	1

EXPLODED DRAWING PARTS LIST - CONTINUED

Ref. No.	Description	Mfr's Part No.	Qty.
38	CONNECT PCB CD6606-01-05	033-006606-600	1
39	DOOR SW. PCB CD6606-01-04	033-006606-600	1
40	CD DOOR OPEN KNOB, MOLD NATURAL (ABS) CAV:1, w/CHROME-PLATED/MASKING	510-660634-001	1
41	MOTOR & LEAF SW. CONNECT PCB CD6606-01-06	033-006606-600	1
42	CASSETTE SPRING PLATE, T=0.3mm STAINLESS STEEL	650-128136-000	1
43	MOTOR-DC-012V-NORMAL 12V #WRF-370C-15370	MOT1 151-121537-001	1
44	LEAF SWITCH LSA-1120Y2/LS35 (CdF)	SW91 022-001120-002	1
45	MOTOR PULLEY, MOLDED NATURAL, CAV.8 (POM)	509-131228-000	1
46	GEAR BRACKET, MOLDED WHITE, CAV.1 (ABS)	505-660617-000	1
47	CD DOOR GEAR, MOLDED NATURAL, CAV.1 (POM)	509-660642-001	1
48	GEAR MOUNTING BRACKET, T=0.8mm E.G. STEEL	605-660645-000	1
49	MIDDLE GEAR, MOLDED NATURAL, CAV.1 (POM)	509-660641-001	1
50	PULLEY GEAR, MOLDED NATURAL, CAV.1 (POM)	509-660640-001	1
51	PULLEY BELT, DIA:36x1.2x1.2 RUBBER RING	700-227039-001	1
52	CD COVER, MOLDED BLACK, CAV.2 (ABS)	500-128116-000	1
53	CD&-TLB-01-SAMG-N CD MECHANISM CMS-B31BG6U	153-000316-000	1
54	*CdF CD CUSHION HARDNESS TO BE 40+2 DEGREE DURO, (CD1892-39)	700-189239-000	4
55	CD CUSHION CAP, MOLDED BLACK, CAV.12 (ABS)	509-130153-000	2
56	POWER PCB CD6606-01-03	033-006606-600	1
57	CASSETTE & CD PCB CD6606-01-02	033-006606-600	1
58	(F550-266422-000) MOUNTING BRACKET, MOLDED NATURAL, CAV.8 (ABS)	4/MPCB 505-266422-000	4
59	HEATSINK (5W) EXTRUDE AL. SIZE:40(L)x71(W)x15.6(H)	613-660658-001	1
60	EXT SP JACK HSP-104V-01/MSP-104V-01 RED, BLK, BLK, RED (PUSH TERMINAL BOARD)	JK302 118-040104-000	1
61	HEADPHONE JACK STEREO 3.5mm #MSJ-2000, HSJ2000-01-110 (8Z-CS1-604-01) (Cd FREE)	JK301 116-002000-352	1
62	HEAT SINK, T=2.0mm ALUMINIUM	613-0CDG74-000	1
63	REGULATOR HEATSINK, T=0.5mm ZN-PLATED STEEL	613-660675-000	1
64	TRANSFORMER MOUNTING BRACKET, T=1.0mm, (E.G.STEEL)	605-660646-000	1
65	TRANSFORMER SHIELD PLATE, T=0.35mm (Z-11 STEEL PLATE)	650-660681-000	1
66	POWER TRANSFORMER w/FUSE 115°C	T901 123-486201-140	1
67	CORD CLAMP WASHER (SUCCESS)	532-900003-001	1
68	RECTIFIER PCB CD6606-01-09	033-006606-101	1
69	CASS KNOB COVER RUBBER, 8x8x2mm THK PORON HH48C	700-130148-000	2
70	BACK CABINET, MOLD COLOR (HIPS) CAV:1 (4 ohm), w/PNT, w/FM PIGTAIL, w/o BEATCUT	500-660602-xxx	1
71	FM ANTENNA COVER, MOLD COLOR GREY 11C (ABS) CAV:4	500-630147-008	1
	METAL WASHER DIA:2.8/DIA:9.5x0.5mm	2/CD MECH. 532-202809-550	2
	SCREW ST2.6x17mm BB w/CHROMATE-PLATING	4/CD MECH. 720-110260-172	4
	SCREW ST3x10mm BB HEAD V5.9-6.3 BRASS BASED	720-110300-100	2
	LED SPACER, DIA.4.0xT0.5mm BLACK PVC	700-660870-000	2
	SCREW ST3x6mm HEXAGON HEAD DIA:5.5 NICKEL	723-046606-000	4
	FIBRE WASHER Ø3.5x8x0.4mm (DIA:3x8x0.4mm)	3/PCB 532-303508-040	3
	LED COVER PLATE, 0.5mm THK WHITE PVC	1/LED 650-660671-000	1
	RUBBER PAD, 7.0x4.0x2.0mm (PORON RUBBER)	2/CD DR 700-130152-000	4
		2/CASS DR	
	CASSETTE DOOR CUSHION 4.0x2.0x2.0(T)mm (PORON)	700-660680-000	2
	SCREW ST1.7x10mm, PAB	1/MICRO SWITCH 720-010170-100	1
	SCREW ST2x8mm PAB BLACK	2/FRONT COVER 720-010200-081	2
	SCREW ST2.6x10mm, PAB (M3 HEAD) BRASS BASED	4/GEAR BKT 720-010260-100	4

EXPLODED DRAWING PARTS LIST - CONTINUED

Ref. No.	Description	Mfr's Part No.	Qty.
	SCREW ST2x12mm KAB BLACK ZINC	4/CD DOOR COVER 720-020200-121	4
	SCREW ST2x8mm, PB BRASS BASED	1/TN-9 720-050200-080	1
	SCREW ST2x10mm, PB	2/TN-9 720-050200-100	2
	SCREW ST2x8mm, BB (4 HEAD)	1/LEAF SWITCH 720-110200-080	3
		2/CTRL PCB TO CD DR	
	SCREW ST2.6x8mm BB BRASS BASED	2/DOOR SPEN PCB 720-110260-080	2
	SCREW ST3x8mm, BB HEAD V5.9-6.3, BB BRASS BASED	8/MPCB MOUNTING BKT 720-110300-080	9
		CONNECTION PCB-F. PANEL	
	SCREW ST3x10mm BB HEAD V5.9-6.3 BRASS BASED	1/AUX JACK 720-110300-100	11
		2/SPK JACK	
		3/RECT. PCB	
		5/MAIN PCB	
	SCREW ST3x14mm, BB HEAD V5.9-6.3	2/F. PANEL TO R. CAB. 720-110300-140	2
	SCREW 3x10mm, PM BRASS BASED	1/IC TO HEATSINK 721-010300-100	1
	SCREW 3x4mm PWM BRASS BASED	2/MOTOR 721-030300-040	2
	SCREW 2.6x8mm PWB T.T.S. P TYPE, w/CHROMATE PLATED	1/GEAR PULLEY 722-050269-082	1
	SCREW 2.6x8mm FLAT HEAD T.T.S. P TYPE BLACK	2/GEAR PULLEY 722-060269-081	2
	SCREW 3x12mm BB T.T.S. (P TYPE) (BPZ30P100FNI)	1/CORD WASHER 722-080309-120	1
	SCREW M2x2mm PM T.T.S BLACK (B TYPE)	1/RECORDING PLATE 722-110200-201	1
	SCREW 3x6mm KM T.T.S. BLACK (STTF3x6AB)	4/F. PL TO R. CAB. 722-160300-061	4
	NUT M3x0.5 PITCH Ni (TSB#9270221800)	1/IC TO HEATSINK 725-000030-500	1
	SCREW 3x6mm,PWM CHROMATE PLATING W=7 (F722-080308-100) SCREW ST3x10mm BB T.T.S., (B TYPE)	2/TFR 721-030300-060	2
		2/HEATSINK TO MPCB 722-080307-100	5
		3/IC TO HEATSINK	
	SCREW 3x20mm BB T.T.S. (P TYPE), w/YELLOW ZINC (PTB3x20MC)	4/TX 722-080309-202	4
	SPONGE, SIZE:15mmx15mmx10mm	700-0228A3-000	3
	METAL TIE (CdF)	727-000001-000	1
	4" CABLE/PLASTIC TIE (SKB-1M/CV-100) (CdF)	727-000100-000	8
	PVC TUBE AWG5 INNER DIA:4.72mm (DAE CHANG/TAE IK) (UL/CSA APP.)	UNIT"M" 728-000047-001	0.14
	PVC TUBE AWG3 INNER DIA:6.0mm (UL/CSA APP.), (DAE CHANG/TAE IK)	UNIT"M" 728-000060-001	0.205
	PVC HEAT SHRINKABLE TUBE DIA. 3mm (UNITUNE), (UL/CSA APP) (CdF)	UNIT"M" 728-015030-001	0.021
	PVC TUBE AWG5 INNER DIA:4.72mm (UL/CSA APP.), (DAE CHANG/TAE IK)	UNIT"M" 728-000047-001	0.14
	PVC TUBE AWG3 INNER DIA:6.0mm (UL/CSA APP.), (DAE CHANG/TAE IK)	UNIT"M" 728-000060-001	0.205
	FUSE HOLDER #FH-V-03078 5x20mm, P.B CU/SN-PLATED	550-790000-002	4
	*CdF WIRE JOINT IN/CLIP TYPE CE-2	700-000200-000	2
	*CdF PVC HEAT SHRINKABLE TUBE DIA.3.5mm, (UNITUBE) (UL/CSA APP)	UNIT"M" 728-015035-000	0.11
	EYELET DIA:1.9mmx4mm HEAD:3.3mm (DIA:2.0mm)	726-001900-000	4
SPEAKER SECTION			
1	SPK PANEL TRIM, MOLD COLOR (ABS) CAV:4, w/SPY, H-S (AM89024AL)	509-660621-xxx	2
2	SPEAKER CLOTH #FP-662-0WT (SILVER GREY), WIDTH:60"-62"	(320x220mm)x2 UNIT"YD" 662-0FP662-000	0.12
3	SPEAKER PANEL, MOLDED BLACK (HIPS) CAV:2	500-660622-000	2
4	SPK00005"004OHM0010W w/BLACK CAP, FOAM EDGE MAG: 60x32x10 #125B58-2	131-504010-011	2
5	RUBBER FOOT, DIA:5x2mm THK PORON w/ADHESIVE NITTO 500	700-227030-000	4

EXPLODED DRAWING PARTS LIST - CONTINUED

Ref. No.	Description	Mfr's Part No.	Qty.
6	SPK BOX STAND, MOLD COLOR (HIPS) CAV:2, w/SPY	509-227022-xxx	2
7	SPEAKER PLASTIC FOOT, MOLD BROWN (PMS730C), (HIPS) CAV:4	509-227047-000	4
8	SPK BOX (5W), 9mm PARTICLE BOARD, S:W150xD163xH210mm, WOODEN PVC (TC-F1021)	660-660624-000	2
9	(F700-027362-000) SPEAKER TUBE, MOLDED BLACK, (ABS) DEPTH=60	509-027362-000	2
	SPONGE, SIZE:32mmx8mmx3mm, w/SELF-AHDESIVE TAPE	8/SPK-SPK BOX 700-036883-001	8
	SCREW ST2.6x10mm, PAB (M3 HEAD) BRASS BASED	4/SPK TRIM 720-010260-100	4
	SCREW ST3x10mm, PWAB BRASS BASED W=7	4/SPK 720-030300-100	8
	SCREW ST3x12mm, BB HEAD V5.9-6.3, BB BRASS BASED, (P TYPE)	4/SPK BOX STAND 720-110300-120	4

EXPLODED DRAWINGS

SPEAKER

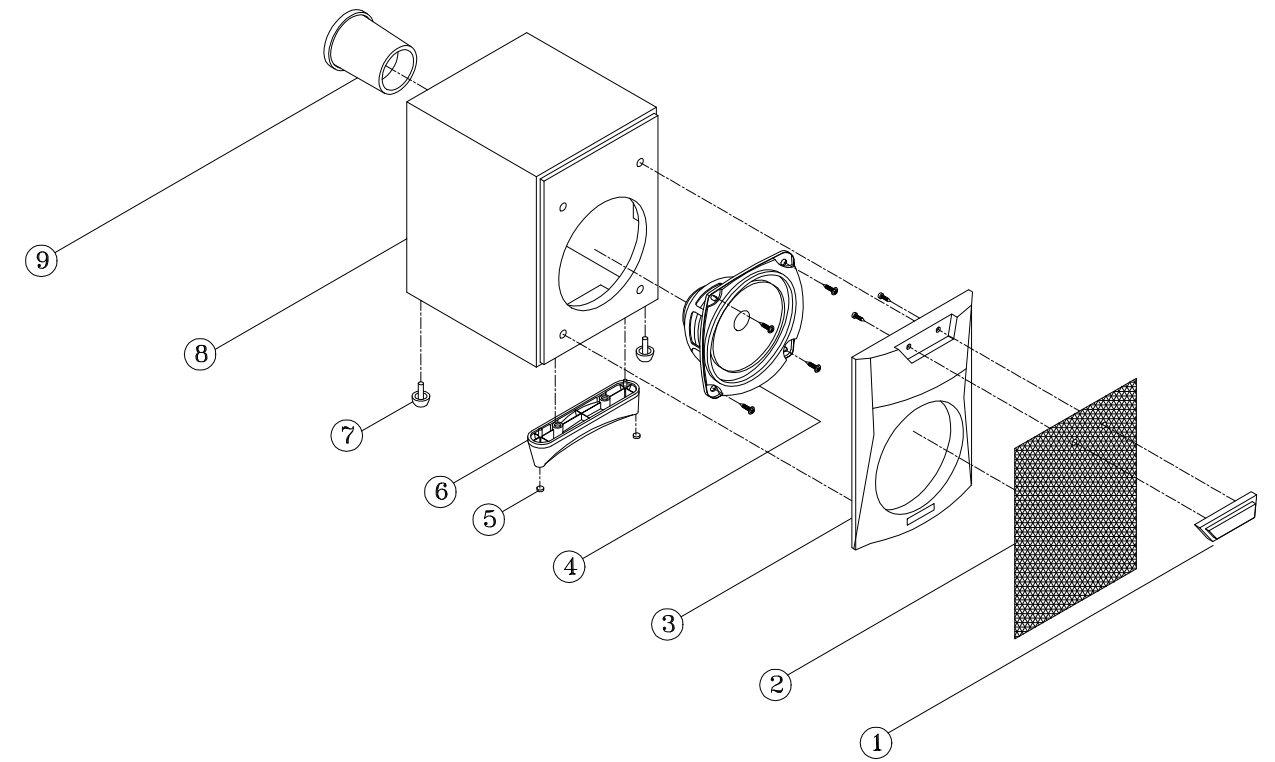

MAIN UNIT

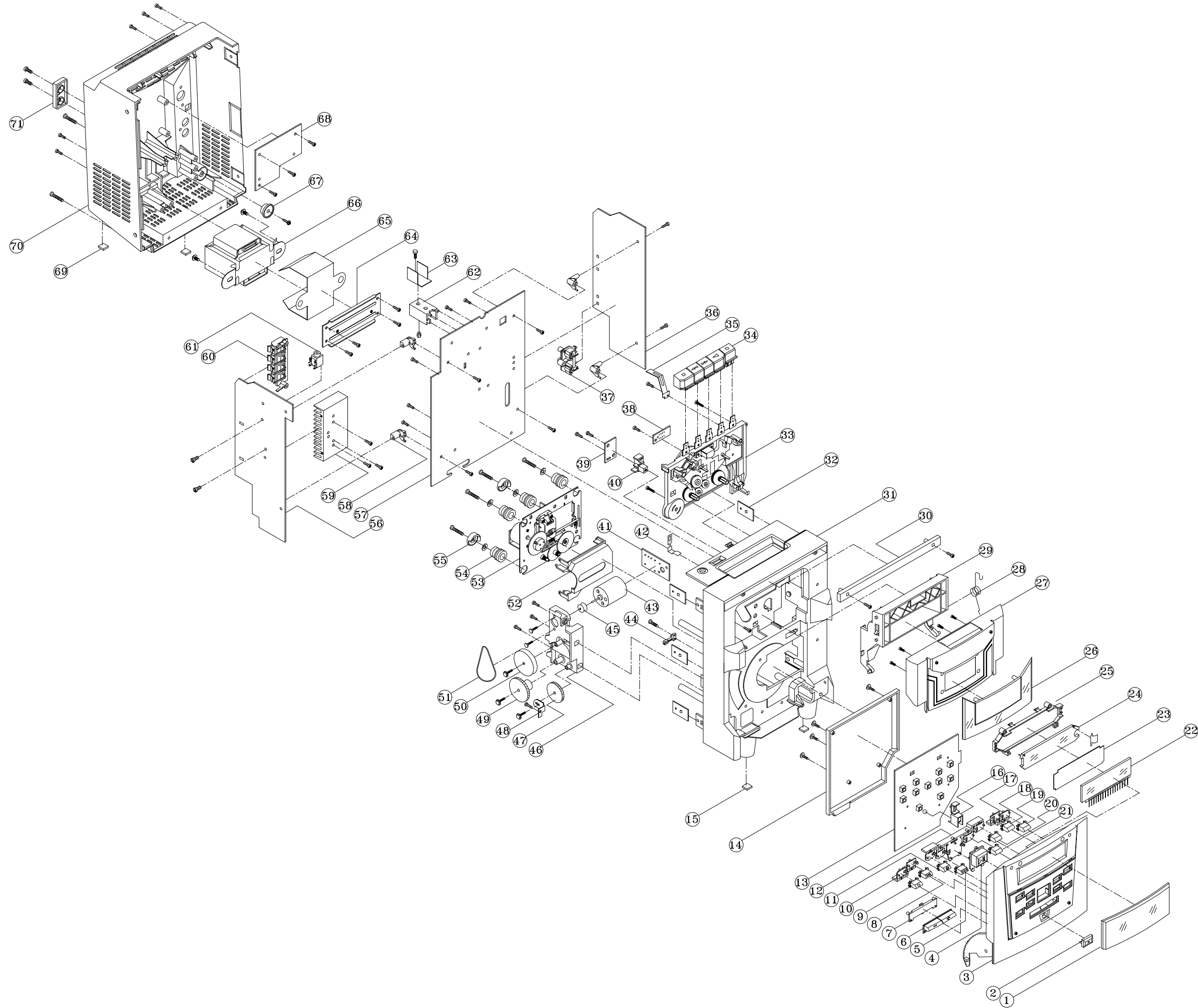

NOTES:

March, 2004