

# AKAI SERVICE MANUAL

**RTV servis Horvat**

Kešinci, 31402 Semeljci

031-856-139

031-856-637

098-788-319

[rtv-servis-horvat@os.tel.hr](mailto:rtv-servis-horvat@os.tel.hr)

Croatia

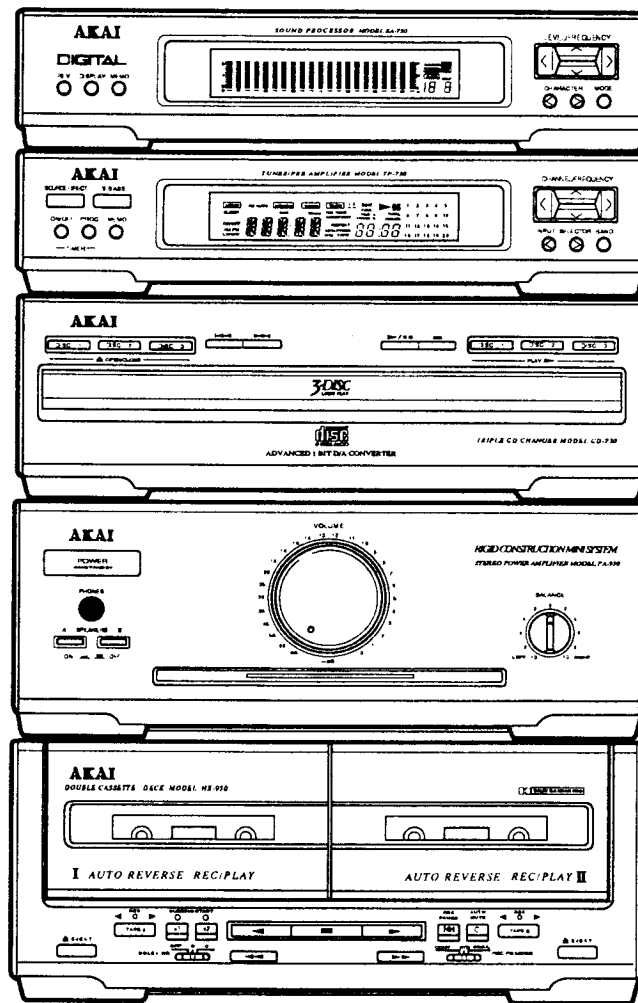

COMPACT  
**disc**  
DIGITAL AUDIO

SYSTEM MX-950

14905

MINI COMPONENT SYSTEM

## MX-750

(TP-750/EA-750/PA-750/HX-750/CD-750)

## MX-950

(TP-750/EA-750/PA-950/HX-950/CD-750)

# TABLE OF CONTENTS

---

SAFETY INSTRUCTIONS .....	3	MODEL CD-750	
INFORMATIONS .....	4	SPECIFICATIONS .....	51
MODEL TP-750		I. DISASSEMBLY .....	52
SPECIFICATIONS .....	5	II. PRINCIPAL PARTS LOCATION .....	53
I. DISASSEMBLY .....	6	III. REPLACEMENT OF	
II. PRINCIPAL PARTS LOCATION .....	7	THE PRINCIPAL COMPONENTS .....	54
III. ADJUSTMENT .....	8	3-1. DISMANTLING PROCEDURE	
3-1. INSTRUMENT CONNECTIONS .....	8	OF THE COMPONENTS .....	54
3-2. ADJUSTMENT .....	9	3-2. REMOVAL OF THE TRAVERSE MECHA. ....	54
IV. PARTS LIST .....	10	3-3. REMOVAL OF THE MAIN PCB .....	54
INDEX .....	13	3-4. REMOVAL OF THE TRAY BLOCK .....	55
ABBREVIATION (TUNER) .....	14	3-5. REPLACEMENT OF THE PICK UP BLOCK ....	55
MODEL EA-750		3-6. REPLACEMENT OF THE SPINDLE MOTOR ....	55
SPECIFICATIONS .....	15	3-7. REPLACEMENT OF THE SLED MOTOR .....	56
I. DISASSEMBLY .....	16	3-8. REPLACEMENT OF THE LOADING MOTOR ....	56
II. PRINCIPAL PARTS LOCATION .....	17	3-9. REPLACEMENT OF THE TABLE MOTOR .....	56
III. PARTS LIST .....	18	IV. ELECTRICAL ADJUSTMENT .....	57
INDEX .....	22	V. PARTS LIST .....	58
MODEL PA-750/950		INDEX .....	62
SPECIFICATIONS .....	23	ABBREVIATIONS (COMPACT DISC) .....	63
I. DISASSEMBLY .....	24		
II. PRINCIPAL PARTS LOCATION .....	25		
III. PARTS LIST .....	26		
INDEX .....	30		
ABBREVIATIONS (AMPLIFIER) .....	31		
MODEL HX-750/950			
SPECIFICATIONS .....	33		
I. DISASSEMBLY .....	34		
II. PRINCIPAL PARTS LOCATION .....	35		
2-1. MODEL HX-750 .....	35		
2-2. MODEL HX-950 .....	36		
III. REPLACEMENT OF PRINCIPAL			
MECHANICAL PARTS .....	37		
3-1. REPLACEMENT OF			
THE PINCH ROLLER BLOCK .....	37		
3-2. REPLACEMENT OF THE PB HEAD			
(MODEL HX-750 TAPE I ONLY) .....	37		
3-3. REPLACEMENT OF THE REC/PB HEAD			
(EXCEPT MODEL HX-750 TAPE I) .....	37		
3-4. REPLACEMENT OF THE CAPSTAN MOTOR ....	37		
3-5. REPLACEMENT OF THE DRIVE BELT .....	37		
IV. MECHANICAL ADJUSTMENT .....	38		
4-1. ADJUSTMENT OF THE PB HEAD AZIMUTH			
ALIGNMENT (MODEL HX-750 TAPE I ONLY) ....	38		
4-2. ADJUSTMENT OF			
THE REC/PB HEAD AZIMUTH ALIGNMENT			
(EXCEPT MODEL HX-750 TAPE I) ....	38		
V. ELECTRICAL ADJUSTMENT .....	39		
5-1. MODEL HX-750 .....	39		
5-2. MODEL HX-950 .....	40		
VI. PARTS LIST .....	41		
INDEX .....	48		
ABBREVIATIONS (CASSETTE) .....	50		

# ★ SAFETY INSTRUCTIONS

## PRECAUTIONS DURING SERVICING

1. Parts identified by the (\*) symbol are critical for safety. Replace them only with the parts number specified.
2. In addition to safety, other parts and assemblies are specified for conformance with such regulations as those applying to spurious radiation. These must also be replaced only with the specified replacements.  
Examples: RF converters, tuner units, antenna selector switches, RF cables, noise blocking capacitors, noise blocking filters, etc.
3. Use specified internal wiring. Note especially:
  - 1) Wires covered with PVC tubing
  - 2) Double insulated wires
  - 3) High voltage leads
4. Use specified insulating materials for hazardous live parts. Note especially:
  - 1) Insulation Tape
  - 2) PVC tubing
  - 3) Spacers (insulating barriers)
  - 4) Insulation sheets for transistors
  - 5) Plastic screws for fixing micro switches
5. When replacing AC primary side components (transformers, power cords, noise blocking capacitors, etc.), wrap the ends of the wires securely around the terminals before soldering.

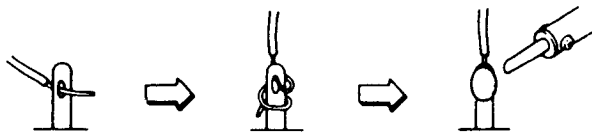

6. Make sure that wires do not contact heat producing parts (heat sinks, oxide metal film resistors, fusible resistors, etc.).
7. Check that replaced wires do not contact sharp edged or pointed parts.
8. Also check areas surrounding repaired locations.
9. Make sure that foreign objects (screws, solder droplets, etc.) do not remain inside the set.

## MAKE YOUR CONTRIBUTION TO PROTECT THE ENVIRONMENT

Used batteries with the ISO symbol for recycling as well as small accumulators (rechargeable batteries), mini-batteries (cells) and starter batteries should not be thrown into the garbage can. Please leave them at an appropriate depot. All other household batteries can be thrown out with the household waste.



## SAFETY CHECK AFTER SERVICING

After servicing, make measurements of leakage-current or resistance in order to determine that exposed parts are acceptably insulated from the supply circuit.

The leakage-current measurement should be done between accessible metal parts (such as chassis, ground terminal, microphone jacks, signal input/output connec-

ohms paralleled with a 0.15  $\mu\text{F}$  capacitor, under the unit's normal working conditions.

The leakage-current should be less than 0.5 mA rms AC. The resistance measurement should be done between accessible exposed metal parts and power cord plug prongs with the power switch (if included) "ON". The resistance should be more than 2.2 M Ohms.

## PRECAUTIONS IN REPAIRING

When repairing or adjusting the unit, please note the following points.

1. Do not put excessive pressure on the mechanical part (operation part), including the pick-up block, as extremely high mechanical precision is required in these parts.
2. When the base is removed for repair or adjustment, make sure that there are no metal objects in the narrow gap between the P.C. board or the mecha parts and the base.
3. The Micro-Computer and the CD signal processing ICs can be damaged by static electricity or leakage from a soldering iron during repairing. While soldering, please take the precautions against leakage as in the illustration.

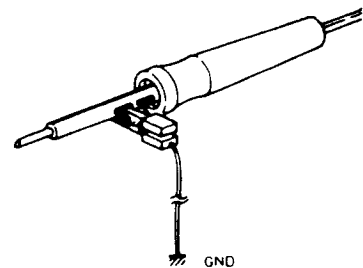

4. Do not loosen any screws in the pick-up block. When handling the pick-up block, please refer to the points to NOTE when replacing the pick up block.
5. To avoid hazardous invisible Laser Radiation, DO NOT look at the Laser Beam (Objective lens) directly.
6. On models for some countries, laser warning labels are affixed on the unit and inside of the unit, as shown below. For your safety, read these labels carefully when repairing or adjusting the unit.

[EUROPE, SCANDINAVIA, UK and AUSTRALIA]

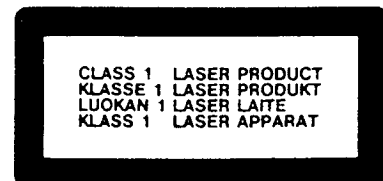

Label affixed on the rear panel of the unit

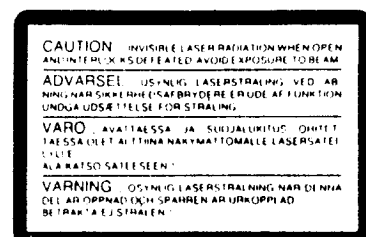

# ★ INFORMATIONS

## SYMBOLS FOR PRIMARY DESTINATION

Alphabet indicates the destination of the units as listed below.

Symbol	Principal Destination
<b>B</b>	UK
<b>E</b>	Europe (except UK)
<b>S</b>	Australia
<b>V</b>	Germany
<b>U</b>	Universal
<b>Y*</b>	Custom version

## VOLTAGE CONVERSION ( **U** Model only)

Before connecting the power cord, set the VOLTAGE SELECTOR located on the rear panel of the PA-750/950 so that the correct voltage for your area is indicated.

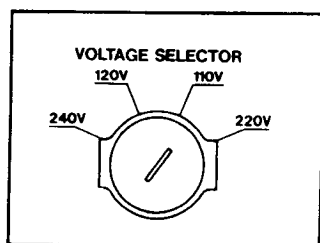

## PRECAUTION ABOUT THE POWER SUPPLY

The power supply of the EA-750, HX-750/950 and CD-750 is supplied from the PA-750/950 through the TP-750. So when repair of the TP-750, EA-750, PA-750/950, HX-750/950 and CD-750 is necessary, repair should be made together with the TP-750, EA-750, PA-750/950, HX-750/950 and CD-750.



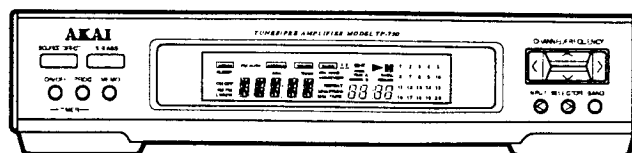

## TUNER/PRE AMPLIFIER

# MODEL TP-750

## SPECIFICATIONS

### Tuner section

#### FM

Tuning frequency range .. 87.5 to 108MHz  
 Usable sensitivity ..... 13.2dBf [E/U], 17.2dBf [V]  
 (IHF, 3% THD)  
 Quieting sensitivity  
 Mono ..... 17.2dBf [E/U], 21.2dBf [V]  
 Stereo ..... 31.2dBf [E/U], 35.2dBf [V]  
 S/N ratio  
 Mono ..... 70dB [E/U], 65dB [V] (IHF)  
 Stereo ..... 60dB (IHF)  
 Frequency response ..... 30Hz to 15kHz ( $\pm 1$ dB)  
 Total harmonic distortion  
 Mono ..... 0.5% (at 1kHz)  
 Stereo ..... 0.3% [E/U], 0.7% [V] (at 1kHz)  
 Selectivity ..... 55dB ( $\pm 400$ kHz)  
 Image rejection ..... 50dB  
 Stereo separation ..... 45dB (at 1kHz)  
 Capture ratio ..... 2dBf  
 AM suppression ..... 60dB  
 Spurious rejection ..... 55dB  
 IF rejection ..... 90dB  
 Output level ..... 500mV [E/U], 450mV [V]  
 (100% MOD)

#### MW

Tuning frequency range .. 531 to 1602kHz (9kHz step)  
 530 to 1710kHz [U]  
 (10kHz step)  
 Usable sensitivity ..... 500 $\mu$ Vm  
 S/N ratio ..... 36dB  
 Selectivity ..... 15dB  
 Image rejection ..... 37dB  
 IF rejection ..... 40dB  
 Output level ..... 150mV (30% MOD)

#### LW

Tuning frequency range .. 144 to 351kHz [E/U],  
 144 to 288kHz [V] (1kHz step)  
 Usable sensitivity ..... 800 $\mu$ Vm  
 S/N ratio ..... 28dB  
 Selectivity ..... 17dB  
 Image rejection ..... 33dB  
 IF rejection ..... 40dB  
 Output level ..... 150mV (30% MOD)

### Pre amplifier Section

Input sensitivity  
 PHONO ..... 3mV/47 ohms  
 VCR/AUX ..... 230mV/22k ohms  
 Output level ..... VCR 150mV/1k ohms  
 S/N ratio  
 PHONO ..... 63dB  
 except PHONO ..... 77dB  
 Residual noise ..... 0.1mV  
 Channel separation ..... 65dB  
 Frequency response ..... 10Hz to 100kHz  
 (10Hz : -4dB, 100kHz : -3dB)  
 Super bass effects ..... 6dB/50Hz (SB-1)  
 12dB/50Hz (SB-2)

### [GENERAL]

Power consumption ..... 10W  
 Dimension ..... 270(W) x 61(H) x 304(D) mm  
 Weight ..... 1.8kg

### Standard accessories

FM long wire antenna ..... x1  
 AM loop antenna ..... x1  
 Plug adaptor ..... x1

# I. DISASSEMBLY

In case of trouble etc., necessitating dismantling, please dismantle in the order shown in the illustrations. Reassemble in the reverse order.

## 1. Removal of the UPPER COVER

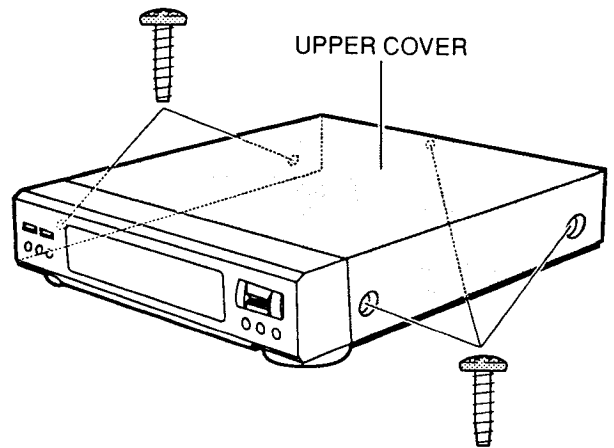

## 2. Removal of the FRONT PANEL

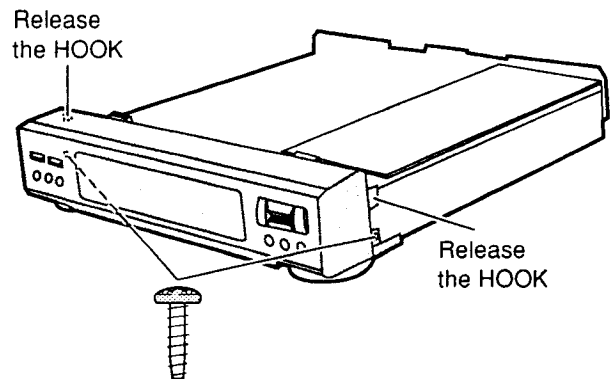
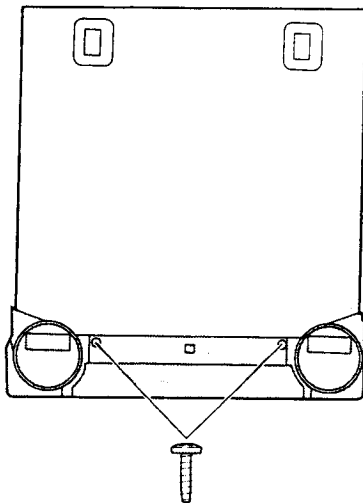

## II. PRINCIPAL PARTS LOCATION

---

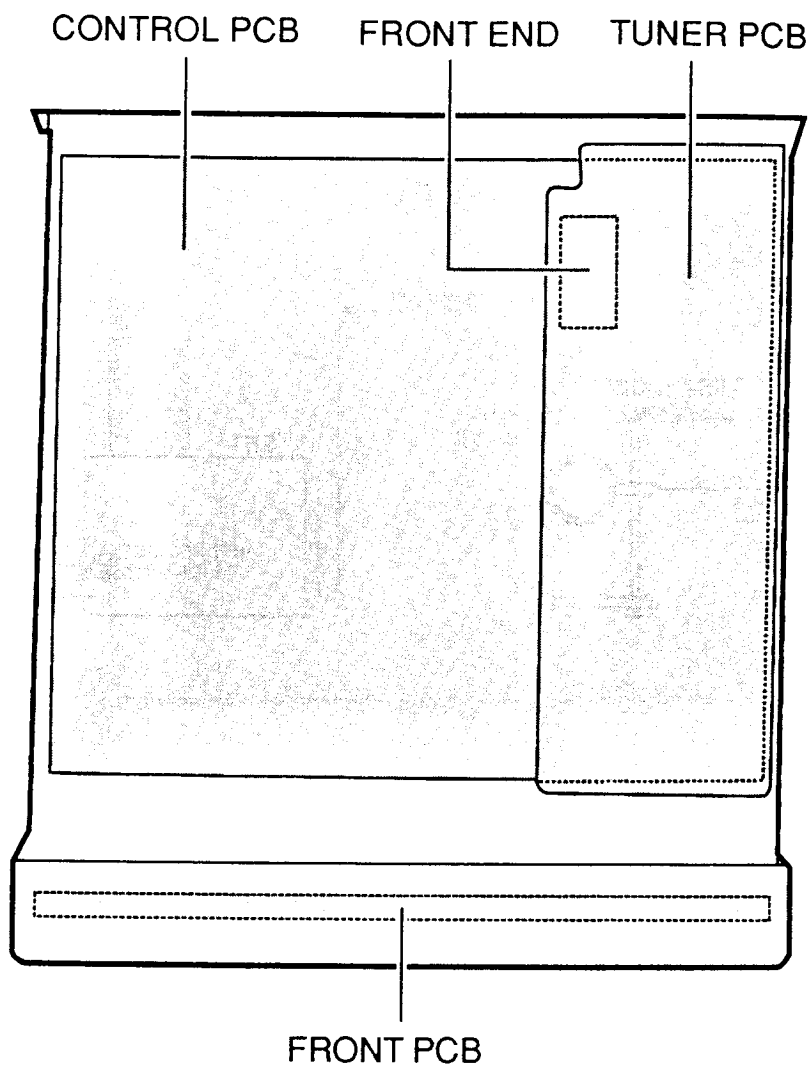

Fig.2-1 Top view

# III. ADJUSTMENT

## 3-1. INSTRUMENT CONNECTIONS

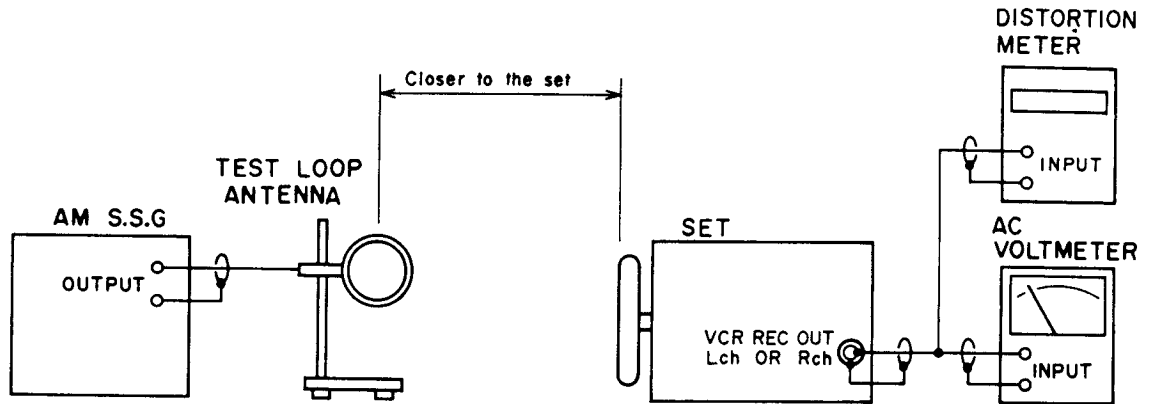

Fig.3-1 Instrument Connection of AM Adjustment

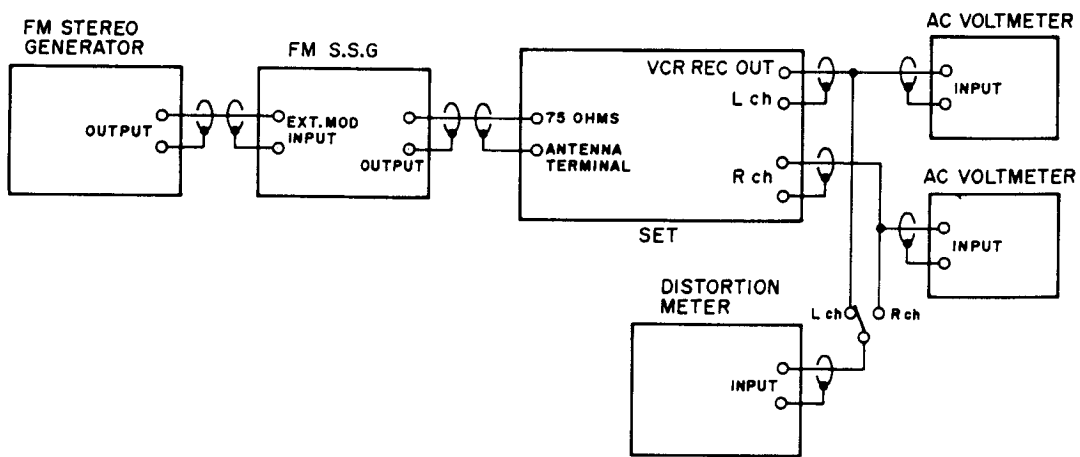

Fig.3-2 Instrument Connection of FM Adjustment

**NOTE:**

Before making adjustment, please set the input to "TUNER" mode by pressing the input SELECTOR button on the TP-750, then select the tuner band with the BAND button according to the adjustment procedure.

# ADJUSTMENT

Set the S.S.G. to 1kHz, 75kHz deviation for **U**, **S**, **B** or **E** model.  
1 kHz, 40 kHz deviation for **V** model.

ADJUSTMENT ITEM	Part	Mark	Result
FREQ. & OUTPUT LEVEL			
Tuning FREQ.			
Part			
MARKS (*) & RESULT (*)			
Point			
Adjustment Part			

**DISTORTION (STEREO)**  
98.0MHz, 60dBμ (STEREO L or R channel only)  
98.0MHz  
IFT (FRONT END)  
Connect the distortion meter to VCR/REC OUT.  
\*Minimum Distortion

**TUNING LED**  
98.0MHz, 22dBμ (MONO)  
98.0MHz  
Tuning LED on the front panel, VR101.  
\*Tuning LED is lit.

**CENTER VOLTAGE**  
98.0MHz, 60dBμ (MONO)  
98.0MHz  
T101  
Connect the DC Digital Voltmeter to both ends of R108.  
0 ± 50mV

**STEREO SEPARATION**  
98.0MHz, 60dBμ (STEREO L or R channel only)  
98.0MHz  
VR102  
Connect the milli-voltmeter to VCR/REC OUT.  
\*Minimum output level for opposite channel.

## LW

- 2 LW SENSITIVITY**
- 162kHz, 75dBμ (Low) or 297kHz <288kHz>, 75dBμ (High)
  - 162kHz PRESET 4 ch, 297kHz <288kHz> PRESET 7 ch.
  - T202 (Low), VC202 (High)
  - Connect the milli-voltmeter to VCR/REC OUT.  
\*Maximum output level.  
\*For best result, repeat Low and High adjustments several times.

**NOTE:** 1. Set the S.S.G to 1kHz 30% modulation on each adjustment.  
2. Frequencies indicated in < > are for the **V** model.

- 1 LW OSC**
- - 351kHz <288kHz> (preset 10 ch)
  - T204
  - Connect the Digital DC Voltmeter between TP1 and GND.  
\*8.2 ± 0.1V <5.75 ± 0.1V>.

## AM

**NOTE:** Set the S.S.G to 1kHz 30% modulation on each adjustment.

- 2 AM (MW) SENSITIVITY**
- 603kHz, 70dBμ (Low) or 1,404kHz, 70dBμ (High)
  - 603kHz (Low), PRESET 8 ch  
1,404kHz (High), PRESET 7 ch
  - T201 (Low), VC201 (High)
  - Connect the milli-voltmeter to VCR/REC OUT.  
\*Maximum output level.  
\*For best result, repeat Low a High adjustments several times.

- 1 AM (MW) OSC**
- - 1,404kHz (PRESET 7 ch)
  - T203
  - Connect the Digital DC Voltmeter between TP1 and GND.  
\*6.7 ± 0.1 V.

- 3 AM IF**
- 162kHz, 65dBμ
  - 162 kHz
  - T205
  - Connect the milli-voltmeter to VCR/REC OUT.  
\*Maximum output level.

- 4 TUNING LED**
- 198kHz, 70dBμ
  - 198kHz
  - Tuning LED on the front panel, VR103.
  - \*Tuning LED is lit.

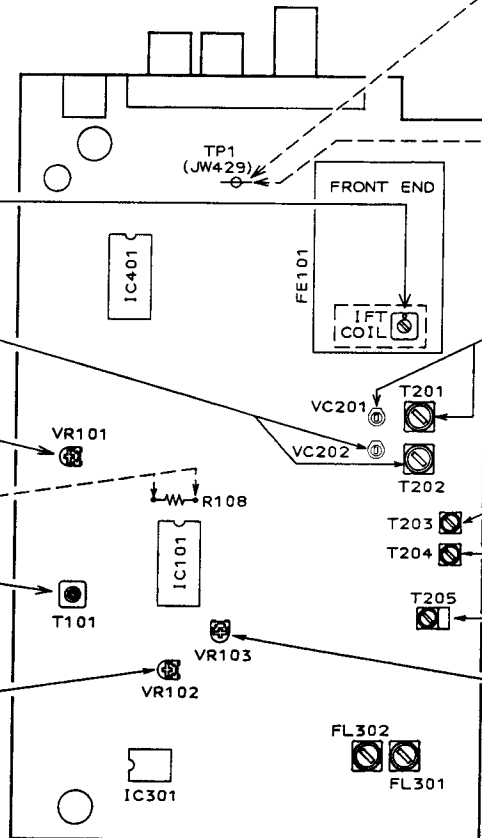

FRONT  
TUNER PCB

# PARTS LIST

## ATTENTION

When placing an order for parts, be sure to list Part No., Model No. and the description of each part. Otherwise, the non-delivery of the part or the delivery of a wrong part may result. Please make sure that Part No. is correct when ordering. If a part different from the one you ordered may be delivered. The parts shown in Parts List of Preliminary Service Manual may have been the subject of changes, please use this Parts List for all future reference.

## HOW TO USE THIS PARTS LIST

This Parts List lists those parts which are considered necessary for repairs. Other common parts, such as resistors and capacitors are listed in the "Common List for Service Parts" from which these parts should be selected and stocked. This Recommended Spare Parts List shows those parts in the Parts List which are considered particularly important for service.

Parts not shown in the Parts List and "Common List for Service Parts" will not in principle be supplied. Please refer to the Parts List.

Head Mechanism Block

### HEAD BASE BLOCK

Part No.	Description
2023A320A	HEAD BASE BLOCK
2206A010A	HEAD R/P PR4-8FU C
7876	PAN20*03STL CMT
6488	BID20*08STL CMT
2895	SP CS ANGLE ADJUST

SP (Service Parts) Classification

This number corresponds with the individual part's index number in that figure.

b) PC Board

### 6. MAIN PC BOARD

Ref. No.	Part No.	Description
IC1	EI-324536	IC HD14049BP
IC2	EI-336801	IC MB8841-564M
C1A	EC-338399	C MMY V 223M 250AC [U,E,B,S]
C1B	EC-350949	C MMY V 223M 250DC [J]
C1C	EC-338397	C MMY V 223M 125AC [C,A]
X1	EI-318384	OSC XTAL NC-18C

Symbols for primary destination

[A]: AAL (U.S.A) [S]: SAA (Australia)  
 [B]: BEAB (England) [U]: U/T (Universal Area)  
 [C]: CSA (Canada)  
 [E]: CEE (Europe) [V]: VDE (Germany)  
 [J]: JPN (Japan) [Y]: Custom Version

SP (Service Parts) Classification

These reference symbols correspond with component symbols in the Schematic Diagrams.

Table PC Board Blocks are listed separately.

If Part No. is known, Parts Index at end of Parts List can be used to locate where that part is shown in Parts List.

Reference No. listed at right of Part No.

## WARNING

INDICATES SAFETY CRITICAL COMPONENTS. FOR CONTINUED SAFETY, REPLACE SAFETY CRITICAL COMPONENTS ONLY WITH MANUFACTURER'S RECOMMENDED PARTS.

## AVERTISSEMENT

INDIQUE LES COMPOSANTS CRITIQUES DE SÉCURITÉ. POUR MAINTENIR LE DEGRÉ DE SÉCURITÉ L'APPAREIL, NE REMPLACER QUE DES PIÈCES RECOMMANDÉES PAR LE FABRICANT.

## 1. RECOMMENDED SPARE PARTS

We suggest you to stock the following Recommended Spare Part items listed below since they can cover most of the routine service.

Ref.No.	Part No.	Description
1	*EC-410588J	C DOUBLE FYPD0H474Z 5.SDC
2	ED-410423J	D LED SEL4914D O ORANGE
3	ED-307572	D SILICON H 1SS131
4	ED-624903	D SILICON H 1S2473
5	*ED-511907	D SILICON 1N4002 100/1.0A
6	ED-372893	D VARACTOR SVC321SPA A DBL
7	ED-397288J	D ZENER H HZS20-2
8	ED-367578	D ZENER H HZS5.6B2J
9	ED-398688J	D ZENER H HZS5B2
10	ED-370786	D ZENER H HZS9.1B2J
11	ED-346559	D ZENER H HZ12B2L
12	ED-346560	D ZENER H HZ12B3L
13	ED-337990	D ZENER H HZ27-1L
14	ED-329058	D ZENER H HZS C1
15	ED-346531	D ZENER H HZ7A2L
16	ED-351418	D ZENER H HZ7B1L
17	ED-346534	D ZENER H HZ7C1L
18	EE-408686J	FRONT END FE415-G10
19	EH-364919	COMP R RKC8BS 473J
20	EH-394759J	FILTER CE SFE10.7MS2GK-A [U,E]
21	EH-338338	FILTER CE SFE10.7MS3GK-A [V]
22	EH-360924	FILTER LC BP BPNB6A [V]
23	EH-405199J	FILTER LC LP K7-J1YD-0170 [V]
24	EH-408815J	FILTER LC LP 42B-5226-03
25	EI-408675J2	IC M38173M6-145FP MXA1TP3
26	EI-382860J	IC BA1521B-DX
27	EI-387938J	IC HD74LS05P
28	EI-408673J	IC LA1851N
29	EI-354951	IC LM7000N
30	EI-213390	IC NJM4558D
31	EI-400756J	IC NJM4558L-B
32	EI-408672J	IC S-80721AN
33	EI-302233	IC TC4051BP
34	EI-332259	IC TC4052BP
35	EI-200573	IC TC4053BP
36	EI-408674J	OSC CE CSB456F15 19.000KHZ
37	EI-405327J	OSC CE CST6.00MGW 6.000MHZ
38	EI-368825M	OSC XTAL C-002RX 32.768KHZ
39	EI-408814M	OSC XTAL HC-49/U 7200KHZ
40	EM-408409J	IND FL 10-MT-44G CHARACTER
41	EO-408689M	COIL DET 1 499HNAS0078Z10.7MHZ
42	EO-408687J	COIL IFT BCFAZ-024
43	EO-363279	COIL OSC 2 A7NRS-9857X 150.0UH
44	EO-352089	COIL OSC 2 7BRS-9098X 580.0UH
45	EO-408808M	COIL VARI 2 MRHNF-45614A
46	EO-408809M	COIL VARI 2 MRZNF-45615A
47	*ER-326169	R FUSE H S10 ERD2FC 1/4W 2R0G
48	*ER-318647	R FUSE H S10 ERD2FC 1/4W 4R7J
49	*ER-386215J	R OMF H S12 FS 1W 220J
50	*ER-408692J	R OMF H S15 FS 2W 390J
51	ES-362883	SW TACT SKHMLM
52	ES-394818J	SW TACT SOR-123HS T05
53	ET-411995J	DETECTOR GP1U581X
54	ET-356336	TR DTA114ES
55	ET-369248	TR DTA114YS
56	ET-354370	TR DTA124ES
57	ET-353897	TR DTC114ES
58	ET-354371	TR DTC124ES
59	ET-373392	TR DTC124XS
60	ET-354094	TR DTC144WS
61	ET-349458	TR FET 2SK192A Y
62	ET-337759	TR FET 2SK246 GR
63	ET-353899	TR 2SA1317 S.T.U
64	*ET-366365	TR 2SB1185 EF
65	ET-397160J	TR 2SC3330 R.S.T.U.V
66	ET-394735J	TR 2SC3792 T05
67	ET-356437	TR 2SC930 D2.EF
68	*ET-366581	TR 2SD1762 E.F
69	*ET-373025	TR 2SD1944 J1J2K
70	ET-401091J	TR 2SD2144S U.V.W T05

Ref.No.	Part No.	Description
71	ET-396072J	TR 2SD2159 V.W
72	EW-408684J	WIRE ASSY HFG0704-0801 L600 4P
73	EW-408682J	WIRE ASSY HFG07115101 L630 11P
74	EW-408678J	WIRE ASSY HFG07157501 L600 15P
75	EW-408679J	WIRE ASSY 52305-1411 L-650 14P
76	EW-408683J	WIRE ASSY 52305-1510 L-300 15P

## 2. P.C BOARD BLK

Ref.No.	Part No.	Description
1A	BA-A6007T030G	ML PC (#) TU-PRE BLKTP-750 (U) /ML
1B	BA-A6007T030H	ML PC (#) TU-PRE BLKTP-750 (E) /ML
1C	BA-A6007T030J	ML PC (#) TU-PRE BLKTP-750 (V) /ML
2	BA-A6009T060A	ML PC SYSCON BLK TP-750/ML

PC (#) TU-PRE BLK CONSISTS OF FOLLOWING P.C BOARD.

- TUNER P.C BOARD
- CONTROL P.C BOARD

## 3. TUNER P.C BOARD

Ref.No.	Part No.	Description
D101	ED-307572	D SILICON H 1SS131
D201	ED-372893	D VARACTOR SVC321SPA A DBL
D202	ED-372893	D VARACTOR SVC321SPA A DBL
D203	ED-307572	D SILICON H 1SS131
D204	ED-307572	D SILICON H 1SS131
D401	ED-367576	D ZENER H HZS5.6B2J
D402	ED-307572	D SILICON H 1SS131
D403	ED-307572	D SILICON H 1SS131
D404	ED-307572	D SILICON H 1SS131
D405	ED-307876	D ZENER H HZS9.1B2J
D406	ED-398688J	D ZENER H HZS5B2
FE101	EE-408686J	FRONT END FE415-G10
FL101	EH-360924	FILTER LC BP BPNB6A [V]
FL102A	EH-394759J	FILTER CE SFE10.7MS2GK-A [U,E]
FL102B	EH-338338	FILTER CE SFE10.7MS3GK-A [V]
FL103A	EH-394759J	FILTER CE SFE10.7MS2GK-A [U,E]
FL103B	EH-338338	FILTER CE SFE10.7MS3GK-A [V]
FL104	EH-405199J	FILTER LC LP K7-J1YD-0170 [V]
FL301	EH-408815J	FILTER LC LP 42B-5226-03
FL302	EH-408815J	FILTER LC LP 42B-5226-03
IC101	EI-408673J	IC LA1851N
IC301	EI-213390	IC NJM4558D
IC401	EI-354951	IC LM7000N
L101	EO-357539	COIL FIX 1 EL0606RA T05 222K
L301	EO-353588	COIL FIX 1 LAPO2 F05 2R2K [V]
L302	EO-353588	COIL FIX 1 LAPO2 F05 2R2K [V]
R107	ER-324184	R CB H S10 FS RDS 1/4W 121J
R108	ER-333387	R CB H S10 FS RDS 1/4W 223J
R425	*ER-318647	R FUSE H S10 ERD2FC 1/4W 4R7J
T101	EO-408689M	COIL DET 1 499HNAS0078Z10.7MHZ
T201	EO-408808M	COIL VARI 2 MRHNF-45614A
T202	EO-408809M	COIL VARI 2 MRZNF-45615A
T203	EO-363279	COIL OSC 2 A7NRS-9857X 150.0UH
T204	EO-352089	COIL OSC 2 7BRS-9098X 580.0UH
T205	EO-408687J	COIL IFT BCFAZ-024
TM1	EJ-359031	TERMINAL LEVER YKD31-0215 P 2P
TR101	ET-356437	TR 2SC930 D2.EF
TR102	ET-397160J	TR 2SC3330 R.S.T.U.V
TR201	ET-349458	TR FET 2SK192A Y
TR202	ET-394735J	TR FET 2SK3792 T05
TR203	ET-353897	TR DTC114ES
TR401	ET-337759	TR FET 2SK246 GR
TR402	ET-397160J	TR 2SC3330 R.S.T.U.V
TR403	ET-354094	TR DTC144WS
TR404	ET-354094	TR DTC144WS
TR405	ET-354094	TR DTC144WS

Ref.No.	Part No.	Description
TR406	ET-353899	TR 2SA1317 S,T,U
TR407	ET-353899	TR 2SA1317 S,T,U
TR408	ET-396072J	TR 2SD2159 V,W
VC201	EC-337603	C S-FIX H VCT51F 5.5-30
VC202	EC-356284	C S-FIX H VCT51G 7.5-50
VR101	EV-358829	R S-FIX H RH0615C 0.10W 223
VR102	EV-356576	R S-FIX H RH0615C 0.10W 472
VR103	EV-356576	R S-FIX H RH0615C 0.10W 472
X101	EI-408674J	OSC CE CSB456F15 19.000KHZ
X401	EI-408814M	OSC X'TAL HC-49/U 7200KHZ

**4. CONTROL P.C BOARD**

Ref.No.	Part No.	Description
C764	*EC-346868	C CE V T05 F 473Z 50DC
C765	*EC-346868	C CE V T05 F 473Z 50DC
C766	*EC-346868	C CE V T05 F 473Z 50DC
C767	*EC-346868	C CE V T05 F 473Z 50DC
C801	*EC-410588J	C DOUBLE FYD0H474Z 5.5DC
D701	ED-346534	D ZENER H HZ7C1L
D702	ED-346534	D ZENER H HZ7C1L
D751	*ED-511907	D SILICON 1N4002 100/1.0A
D752	*ED-511907	D SILICON 1N4002 100/1.0A
D753	*ED-511907	D SILICON 1N4002 100/1.0A
D754	*ED-511907	D SILICON 1N4002 100/1.0A
D755	ED-346559	D ZENER H HZ12B2L
D756	ED-346560	D ZENER H HZ12B3L
D757	*ED-511907	D SILICON 1N4002 100/1.0A
D758	*ED-511907	D SILICON 1N4002 100/1.0A
D759	*ED-511907	D SILICON 1N4002 100/1.0A
D760	ED-337990	D ZENER H HZ27-1L
D761	*ED-511907	D SILICON 1N4002 100/1.0A
D762	*ED-511907	D SILICON 1N4002 100/1.0A
D763	ED-351418	D ZENER H HZ7B1L
D764	ED-346531	D ZENER H HZ7A2L
D765	*ED-511907	D SILICON 1N4002 100/1.0A
D766	ED-511907	D SILICON 1N4002 100/1.0A
D767	ED-511907	D SILICON 1N4002 100/1.0A
D768	ED-329058	D ZENER H HZ5 C1
D801	ED-307572	D SILICON H 1SS131
D802	ED-307572	D SILICON H 1SS131
D803	ED-307572	D SILICON H 1SS131
D804	ED-307572	D SILICON H 1SS131
D805	ED-307572	D SILICON H 1SS131
D806	ED-307572	D SILICON H 1SS131
D807	ED-307572	D SILICON H 1SS131
D808	ED-307572	D SILICON H 1SS131
		[U]
		[V]
D813	ED-307572	D SILICON H 1SS131
D814	ED-511907	D SILICON 1N4002 100/1.0A
D815	ED-307572	D SILICON H 1SS131
D821	ED-397289J	D ZENER H HZS20-2
D822	ED-307572	D SILICON H 1SS131
IB801	EH-364919	COMP R RKC8BS 473J
IC501	EI-302233	IC TC4051BP
IC502	EI-200573	IC TC4053BP
IC601	EI-302233	IC TC4051BP
IC602	EI-200573	IC TC4053BP
IC701	EI-382660J	IC BA15218-DX
IC702	EI-400756J	IC NJM4558L-B
IC703	EI-400756J	IC NJM4558L-B
IC704	EI-332259	IC TC4052BP
IC801	EI-408675J2	IC M38173M6-145FP MXA1TP3
IC802	EI-387938J	IC HD74LS05P
IC803	EI-387938J	IC HD74LS05P
IC804	EI-408672J	IC S-80721AN
J11A	EJ-408671J	PIN J T6592AABB W/SHIELD 8P
		[U,E]
J11B	EJ-408670J	PIN J T6388-AABC 8P
		[V]
R751	*ER-386215J	R OMF H S12 FS 1W 220J
R752	*ER-386215J	R OMF H S12 FS 1W 220J
R759	*ER-386215J	R OMF H S12 FS 1W 220J
R764	*ER-326169	R FUSE H S10 ERD2FC 1/4W 22R0G
R765	*ER-408692J	R OMF H S15 FS 2W 390J
TR501	ET-394735J	TR 2SC3792 T05
TR512	ET-397160J	TR 2SC3330 R,S,T,U,V

Ref.No.	Part No.	Description
TR601	ET-394735J	TR 2SC3792 T05
TR612	ET-397160J	TR 2SC3330 R,S,T,U,V
TR752	*ET-373025	TR 2SD1944 J1,J2,K
TR753	ET-353899	TR 2SA1317 S,T,U
TR754	*ET-366365	TR 2SB1185 E,F
TR755	ET-353899	TR 2SA1317 S,T,U
TR756	*ET-366365	TR 2SB1185 E,F
TR757	ET-397160J	TR 2SC3330 R,S,T,U,V
TR758	*ET-366581	TR 2SD1762 E,F
TR759	ET-397160J	TR 2SC3330 R,S,T,U,V
TR760	ET-353899	TR 2SA1317 S,T,U
TR761	ET-353899	TR 2SA1317 S,T,U
TR801	ET-354371	TR DTC124ES
TR802	ET-354371	TR DTC124ES
TR803	ET-354371	TR DTC124ES
TR804	ET-354371	TR DTC124ES
TR805	ET-354371	TR DTC124ES
TR806	ET-353897	TR DTC114ES
TR807	ET-354371	TR DTC124ES
TR808	ET-354370	TR DTA124ES
TR809	ET-373392	TR DTC124XS
TR810	ET-369248	TR DTA114YS
TR811	ET-353897	TR DTC114ES
TR812	ET-354370	TR DTA124ES
TR815	ET-353899	TR 2SA1317 S,T,U
TR816	ET-354371	TR DTC124ES
TR817	ET-356336	TR DTA114ES
TR818	ET-401091J	TR 2SD2144S U,V,W T05
TR819	ET-401091J	TR 2SD2144S U,V,W T05
TS801	ES-362883	SW TACT SKHMLM
W1	EW-408678J	WIRE ASSY HFG07157501 L600 15P
W2	EW-408679J	WIRE ASSY 52305-1411 L=650 14P
W3	EW-408682J	WIRE ASSY HFG07115101 L630 11P
W4	EW-408683J	WIRE ASSY 52305-1510 L=300 15P
W5	EW-408684J	WIRE ASSY HFG0704-0801 L600 4P
X801	EI-405327J	OSC CE CST6.00MGW 6.000MHZ
X802	EI-368825M	OSC X'TAL C-002RX 32.768KHZ

**5. FRONT P.C BOARD**

Ref.No.	Part No.	Description
D851	ED-624903	D SILICON H 1S2473
D852	ED-624903	D SILICON H 1S2473
D853	ED-624903	D SILICON H 1S2473
D854	ED-624903	D SILICON H 1S2473
D855	ED-624903	D SILICON H 1S2473
D856	ED-624903	D SILICON H 1S2473
D857	ED-624903	D SILICON H 1S2473
D861	ED-410423J	D LED SEL4914D D ORANGE
D862	ED-410423J	D LED SEL4914D D ORANGE
HS851	ET-411995J	DETECTOR GP1U581X
IN851	EM-408409J	IND FL 10-MT-44GK CHARACTER
TR851	ET-353897	TR DTC114ES
TS851	ES-394818J	SW TACT SOR-123HS T05
TS852	ES-394818J	SW TACT SOR-123HS T05
TS853	ES-394818J	SW TACT SOR-123HS T05
TS854	ES-394818J	SW TACT SOR-123HS T05
TS855	ES-394818J	SW TACT SOR-123HS T05
TS856	ES-394818J	SW TACT SOR-123HS T05
TS857	ES-394818J	SW TACT SOR-123HS T05
TS858	ES-394818J	SW TACT SOR-123HS T05
TS859	ES-394818J	SW TACT SOR-123HS T05
TS860	ES-394818J	SW TACT SOR-123HS T05
TS861	ES-394818J	SW TACT SOR-123HS T05
TS862	ES-394818J	SW TACT SOR-123HS T05
W852	EW-408819J1	CORD A6009 L=130 13P
W853	EW-408819J1	CORD A6009 L=130 13P
W854	EW-408818J1	CORD A6009 L=130 9P

A 8  
 Ti 154

## FINAL ASSEMBLY

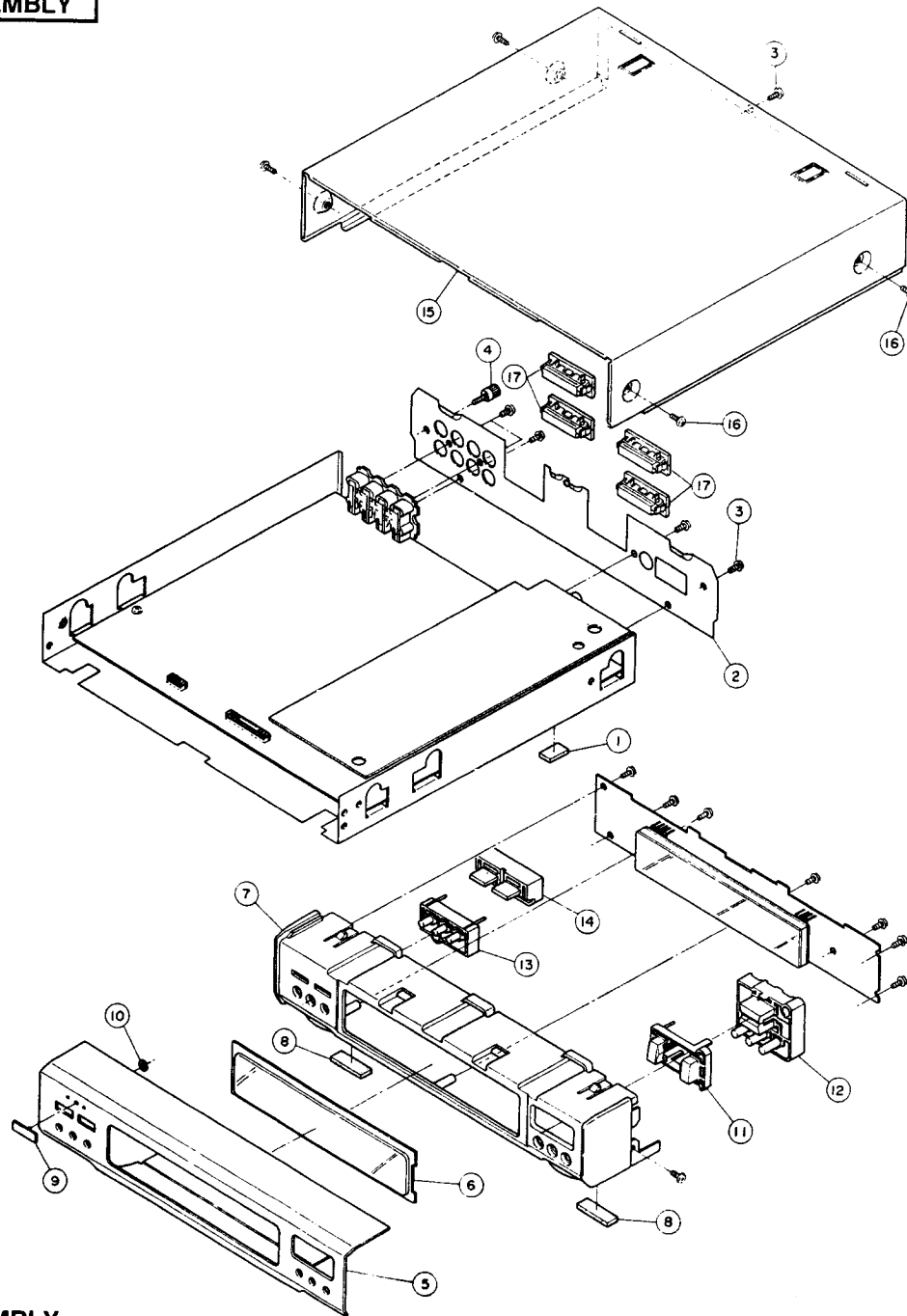

### 6. FINAL ASSEMBLY

Ref.No.	Part No.	Description
1	SA-407840M	CUSHION FOOT REAR (SG)
2A	SP-407974M	PANEL REAR TP-750 (U) (SG)
2B	SP-407975M	PANEL REAR TP-750 (E) (SG)
2C	SP-407976M	PANEL REAR TP-750 (V) (SG)
3	ZS-394412M	BT BID30X08STL BZN PROJECTION
4	EJ-393745J	TERMINAL W/SCREW UB-0132
5	SP-407959J	PANEL FRONT-TP
6	SE-407964M	WINDOW FLD-TP (SG)
7	SE-407956M	ESCUTCHEON FRONT (SG)
8	SA-394136M	CUSHION FOOT (SG)
9	SM-409218J	NAME PLATE AKAI-S
10	ZW-408744J	PUSH NUT SPN-2
11	SB-407961M	BUTTON FR (SG)
12	SB-407962M	BUTTON OP (SG)
13	SB-407965M	BUTTON MEMO (SG)
14	SB-407966M	BUTTON SOURCE (SG)
15	SP-407980M	COVER UPPER-TP (SG)
16	ZS-331182	BT BID30X08STL BNI
17	SZ-407909M	WIRE HOLDER

### NOTE:

Parts will not be supplied if they are not listed in the parts list, even if they appear on the assembling illustrations with reference No.

### 7. ACCESSORY

Ref.No.	Part No.	Description
1	EE-394420M1	ANT LOOP LA-75
2	EE-396107M	ANT WIRE FM A3063
3	EJ-394417J	SOCKET COAX HXC 0526-01-010



# INDEX

Part No.	Ref. No.	Part No.	Ref. No.	Part No.	Ref. No.	Part No.	Ref. No.
BAA6007T030G	2-1A	EH364919	4-IB801	ET353899	4-TR755		
BAA6007T030H	2-1B	EH394759J	3-FL102A	ET353899	4-TR760		
BAA6007T030J	2-1C	EH394759J	3-FL103A	ET353899	4-TR761		
BAA6009T060A	2-2	EH405199J	3-FL104	ET353899	4-TR815		
EC337603	3-VC201	EH408815J	3-FL301	ET354094	3-TR403		
EC346868	4-C764	EH408815J	3-FL302	ET354094	3-TR404		
EC346868	4-C765	EI200573	4-IC502	ET354094	3-TR405		
EC346868	4-C766	EI200573	4-IC602	ET354370	4-TR808		
EC346868	4-C767	EI213390	3-IC301	ET354370	4-TR812		
EC356284	3-VC202	EI302233	4-IC501	ET354371	4-TR801		
EC410588J	4-C801	EI302233	4-IC601	ET354371	4-TR802		
ED307572	3-D101	EI332259	4-IC704	ET354371	4-TR803		
ED307572	3-D203	EI354951	3-IC401	ET354371	4-TR804		
ED307572	3-D204	EI368825M	4-X802	ET354371	4-TR805		
ED307572	3-D402	EI382660J	4-IC701	ET354371	4-TR807		
ED307572	3-D403	EI387938J	4-IC802	ET354371	4-TR816		
ED307572	3-D404	EI387938J	4-IC803	ET356336	4-TR817		
ED307572	4-D801	EI400756J	4-IC702	ET356437	3-TR101		
ED307572	4-D802	EI400756J	4-IC703	ET366365	4-TR754		
ED307572	4-D803	EI405327J	4-X801	ET366365	4-TR756		
ED307572	4-D804	EI408672J	4-IC804	ET366581	4-TR758		
ED307572	4-D805	EI408673J	3-IC101	ET369248	4-TR810		
ED307572	4-D806	EI408674J	3-X101	ET373025	4-TR752		
ED307572	4-D807	EI408675J2	4-IC801	ET373392	4-TR809		
ED307572	4-D808	EI408814M	3-X401	ET394735J	3-TR202		
ED307572	4-D813	EJ359031	3-TM1	ET394735J	4-TR501		
ED307572	4-D815	EJ393745J	6-4	ET394735J	4-TR601		
ED307572	4-D822	EJ394417J	7-3	ET396072J	3-TR408		
ED329058	4-D768	EJ408670J	4-J11B	ET397160J	3-TR102		
ED337990	4-D760	EJ408671J	4-J11A	ET397160J	3-TR402		
ED346531	4-D764	EM408409J	5-IN851	ET397160J	4-TR512		
ED346534	4-D701	EO352089	3-T204	ET397160J	4-TR612		
ED346534	4-D702	EO353588	3-L301	ET397160J	4-TR757		
ED346559	4-D755	EO353588	3-L302	ET397160J	4-TR759		
ED346560	4-D756	EO357539	3-L101	ET401091J	4-TR818		
ED351418	4-D763	EO363279	3-T203	ET401091J	4-TR819		
ED367576	3-D401	EO408687J	3-T205	ET411995J	5-HS851		
ED370786	3-D405	EO408689M	3-T101	EV356576	3-VR102		
ED372893	3-D201	EO408808M	3-T201	EV356576	3-VR103		
ED372893	3-D202	EO408809M	3-T202	EV358829	3-VR101		
ED389688J	3-D406	ER318647	3-R425	EW408678J	4-W1		
ED397289J	4-D821	ER324184	3-R107	EW408679J	4-W2		
ED410423J	5-D861	ER326169	4-R764	EW408682J	4-W3		
ED410423J	5-D862	ER333387	3-R108	EW408683J	4-W4		
ED511907	4-D751	ER386215J	4-R751	EW408684J	4-W5		
ED511907	4-D752	ER386215J	4-R752	EW408818J1	5-W854		
ED511907	4-D753	ER386215J	4-R759	EW408819J1	5-W852		
ED511907	4-D754	ER408692J	4-R765	EW408819J1	5-W853		
ED511907	4-D757	ES362883	4-TS801	SA394136M	6-8		
ED511907	4-D758	ES394818J	5-TS851	SA407840M	6-1		
ED511907	4-D759	ES394818J	5-TS852	SB407961M	6-11		
ED511907	4-D761	ES394818J	5-TS853	SB407962M	6-12		
ED511907	4-D762	ES394818J	5-TS854	SB407965M	6-13		
ED511907	4-D765	ES394818J	5-TS855	SB407966M	6-14		
ED511907	4-D766	ES394818J	5-TS856	SE407956M	6-7		
ED511907	4-D767	ES394818J	5-TS857	SE407964M	6-6		
ED511907	4-D814	ES394818J	5-TS858	SM409218J	6-9		
ED624903	5-D851	ES394818J	5-TS859	SP407959J	6-5		
ED624903	5-D852	ES394818J	5-TS860	SP407974M	6-2A		
ED624903	5-D853	ES394818J	5-TS861	SP407975M	6-2B		
ED624903	5-D854	ES394818J	5-TS862	SP407976M	6-2C		
ED624903	5-D855	ET337759	3-TR401	SP407980M	6-15		
ED624903	5-D856	ET349458	3-TR201	SZ407909M	6-17		
ED624903	5-D857	ET353897	3-TR203	ZS331182	6-16		
EE394420M1	7-1	ET353897	4-TR806	ZS394412M	6-3		
EE396107M	7-2	ET353897	4-TR811	ZW408744J	6-10		
EE408686J	3-FE101	ET353897	5-TR851				
EH338338	3-FL102B	ET353899	3-TR406				
EH338338	3-FL103B	ET353899	3-TR407				

## ABBREVIATIONS (TUNER)

ABBREVIATION	EXPLANATION	ABBREVIATION	EXPLANATION
AFC	Auto Frequency Control	MEMO	MEMORy
AGC	Auto Gain Control	MI-COM	Micro-COMputer
ALC	Auto Level Control	MIN	MINimum
AM	Amplitude Modulation	MIX	MIXing
AMP	AMPLifier	MPX	MultiPleX
ANT	ANTenna	MW	Medium Wave (frequency)
BATT	BATTery	NC	No Connection
BLK	BLock	NFB	Negative Feed Back
BUFF	BUFFer	OSC	OSCillator
COMP	COMPalator	PCB	Printed Circuit Board
DET	DETECT (DETECTor)	PLL	Phase Locked Loop
FLD	FLuorescent Display	Q.D	Quadrature Detector
FM	Frequency Modulation	Rch	Right channel
FREQ	FREQuency	REF	REFerence
GND	GrouND	REG	REGulator
H	Hight	RF	Radio Frequency
HPF	Hight Pass Filter	SEG	SEGment
IF	Intermediate Frequency	SELE	SELEctor
IHF	Institut of High Fidelity	SENS	SENSitivity
IND	INDicator	SIG	SIGNAL
I/O	In/Out	S/N	Signal to Noise ratio
JW	Jumper Wire	SSG	Standard Signal Generator
L	Low	STD	STanDard
LCD	Liquid Crystal Display	SW	SWitch: Short Wave (frequency)
Lch	Left channel	THD	Total Harmonic Distortion
LED	Light Emiting Diode	TP	Test Point
LPF	Low Pass Filter	VCO	Voltage Controlled Oscillator
LW	Long Wave (Frequency)	VR	Variable Resistor
		X'TAL	Crystal

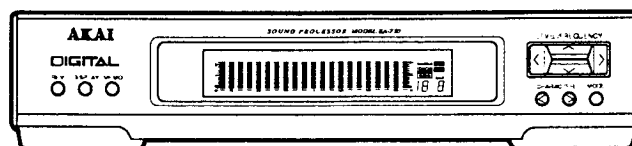

DIGITAL SOUND PROCESSOR

MODEL **EA-750**

**SPECIFICATIONS**

Center frequency .....	63Hz/160Hz/400Hz/1kHz/2.5kHz/6.3kHz/16kHz
Control range .....	-10dB (2dB step)
S/N ratio .....	100dB (A-Weight)
Total harmonic distortion .....	0.008% (1kHz, flat)
Power consumption .....	10W
Dimensions .....	270 (W) X 61 (H) X 295 (D)mm
Weights .....	1.6kg

# I. DISASSEMBLY

In case of trouble, etc., necessitating dismantling, please dismantle in the order shown in the illustrations. Reassemble in the reverse order.

## 1. Removal of the UPPER COVER

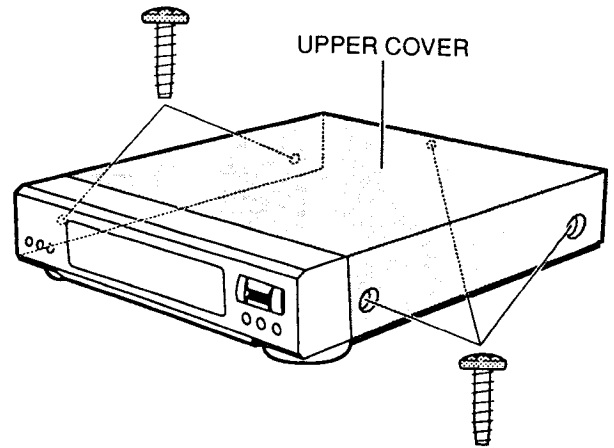

## 2. Removal of the FRONT PANEL

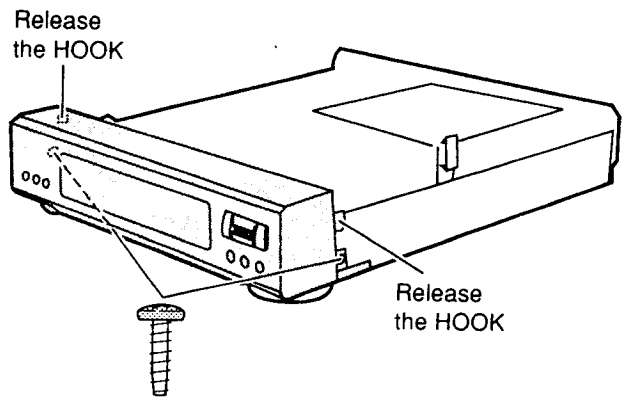
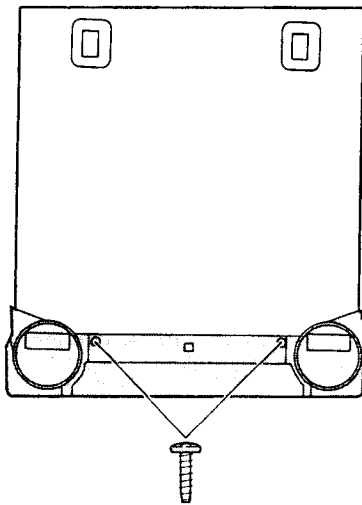

## II. PRINCIPAL PARTS LOCATION

---

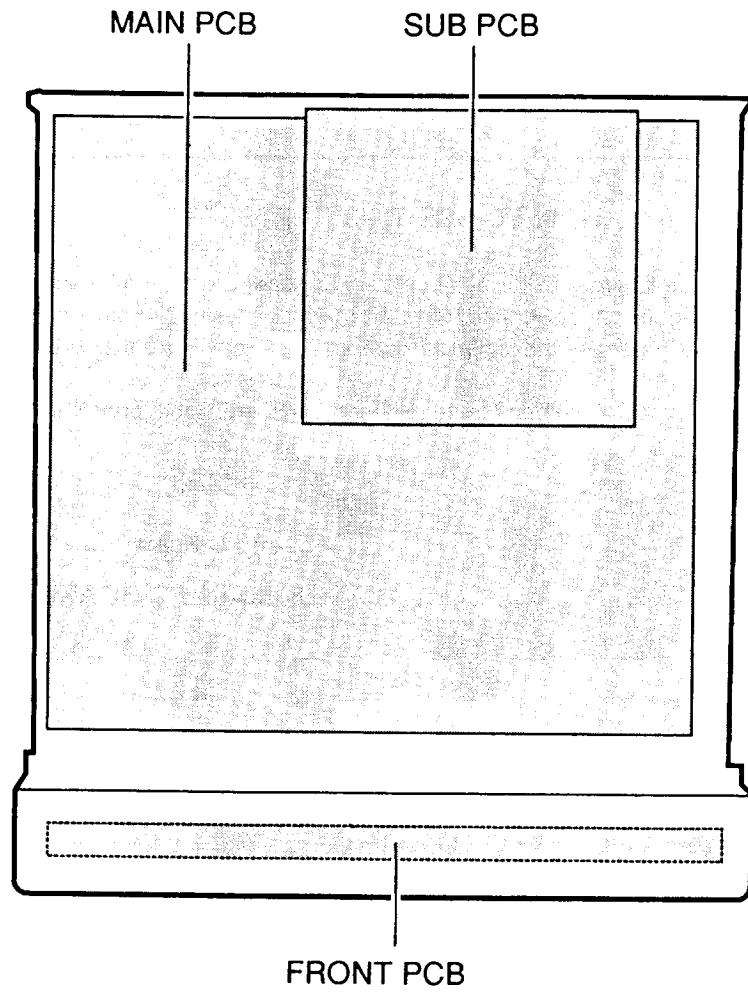

Fig.2-1 Top view

# III. PARTS LIST

## ATTENTION

1. When placing an order for parts, be sure to list Part No., Model No. and the description of each part. Otherwise, the non-delivery of the part or the delivery of a wrong part may result.
2. Please make sure that Part No. is correct when ordering.  
If not, a part different from the one you ordered may be delivered.
3. Since the parts shown in Parts List of Preliminary Service Manual may have been the subject of changes, please use this Parts List for all future reference.

## HOW TO USE THIS PARTS LIST

1. This Parts List lists those parts which are considered necessary for repairs. Other common parts, such as resistors and capacitors, are listed in the "Common List for Service Parts" from which these parts should be selected and stocked.
2. The Recommended Spare Parts List shows those parts in the Parts List which are considered particularly important for service.
3. Parts not shown in the Parts List and "Common List for Service Parts" will not in principle be supplied.
4. How to read the Parts List.

a) Mechanism Block

### 2. HEAD BASE BLOCK

Ref. No.	Part No.	Description
1	BH-T2023A320A	HEAD BASE BLOCK
2	HP-H2206A010A	HEAD R/P PR4-8FU C
3	ZS-477876	PAN20×03STL CMT
4	ZS-536488	BID20×08STL CMT
5	ZG-402895	SP CS ANGLE ADJUST

SP (Service Parts) Classification

This number corresponds with the individual parts index number in that figure.

b) PC Board

### 6. MAIN PC BOARD

Ref. No.	Part No.	Description
IC1	EI-324536	IC HD14049BP
IC2	EI-336801	IC MB8841-564M
C1A	EC-338399	C MMY V 223M 250AC [U,E,B,S]
C1B	EC-350949	C MMY V 223M 250DC [J]
C1C	EC-338397	C MMY V 223M 125AC [C,A]
X1	EI-318384	OSC X'TAL NC-18C

Symbols for primary destination

[A] : AAL (U.S.A)      [S] : SAA (Australia)  
 [B] : BEAB (England) [U] : U/T (Universal Area)  
 [C] : CSA (Canada)  
 [E] : CEE (Europe)    [V] : VDE (Germany)  
 [J] : JPN (Japan)      [Y] : Custom Version

SP (Service Parts) Classification

These reference symbols correspond with component symbols in the Schematic Diagrams.

The available PC Board Blocks are listed separately.

5. When Part No. is known, Parts Index at end of Parts List can be used to locate where that part is shown in Parts List by its Reference No. listed at right of Part No.

## WARNING

⚠ (\*) INDICATES SAFETY CRITICAL COMPONENTS. FOR CONTINUED SAFETY, REPLACE SAFETY CRITICAL COMPONENTS ONLY WITH MANUFACTURE'S RECOMMENDED PARTS.

## AVERTISSEMENT

⚠ (\*) IL INDIQUE LES COMPOSANTS CRITIQUES DE SÉCURITÉ. POUR MAINTENIR LE DEGRÉ DE SÉCURITÉ DE L'APPAREIL, NE REMPLACER QUE DES PIÈCES RECOMMANDÉES PAR LE FABRICANT.

## 1. RECOMMENDED SPARE PARTS

We suggest you to stock the following Recommended Spare Part items listed below since they can cover most of the routine service.

Ref.No.	Part No.	Description
1	ED-307572	D SILICON H 1SS131
2	ED-624903	D SILICON H 1S2473
3	*ED-511907	D SILICON 1N4002 100/1.0A
4	ED-346559	D ZENER H HZ12B2L
5	ED-346620	D ZENER H HZ27 2
6	*ED-346529	D ZENER H HZ6C2L
7	ED-346538	D ZENER H HZ9A2L
8	ED-400519J	D ZENER H MTZJ3.9A T26
9	ED-403978J	D ZENER H UTZJ5.1B T26
10	*ED-405446J	D ZENER H UTZJ5.6B T26
11	EH-408801J	COMP R RGL7T 105J
12	EI-387938J	IC HD74LS05P
13	EI-359053	IC LA3600
14	EI-408647J	IC LC7522
15	EI-408798J	IC M38173M6-143FP MXB1GE1
16	EI-403308J	IC M50194P
17	EI-393323J	IC M5218AL-771
18	EI-408810J	IC M5289P-610
19	EI-408797J	IC M74HC154P
20	EI-400756J	IC NJM4558L-B
21	EI-408393J	IC ST24C01B1
22	EI-302233	IC TC4051BP
23	EI-332259	IC TC4052BP
24	EI-200573	IC TC4053BP
25	EI-408646J	IC XR1091ECP
26	EI-382875J	OSC CE CST4.00MGW 4MHZ
27	EI-405327J	OSC CE CST6.00MGW 6.000MHZ
28	EM-408411J	IND FL BU048GK DOUBLE
29	*ER-345751	R FUSE H S10 ERD2FC 1/4W 15R0G
30	*ER-408806J	R OMF H S12 FS 1W 470J
31	*ER-408267J	R OMF H S15 FS 2W 5R6J
32	ES-394818J	SW TACT SOR-123HS T05
33	ET-354370	TR DTA124ES
34	ET-396487J	TR DTA124XL T05
35	ET-354415	TR DTA144ES
36	ET-354414	TR DTC144ES
37	*ET-353899	TR 2SA1317 S,T,U
38	ET-352726	TR 2SA1392 T,U
39	*ET-366365	TR 2SB1185 E,F
40	*ET-356817	TR 2SB891 Q,R
41	*ET-397160J	TR 2SC3330 R,S,T,U,V
42	ET-378524J	TR 2SC3383 S,T,U
43	ET-361736	TR 2SC3576
44	*ET-354083	TR 2SD1189 Q,R
45	*ET-366581	TR 2SD1762 E,F

## 2. P.C BOARD BLK

Ref.No.	Part No.	Description
1	BA-D3016T030A	ML PC MAIN EA BLK EA-750/ML
2	BA-D3016T040A	ML PC (#) SUB EA BLK EA-750/ML

PC (#) SUB EA BLK CONSISTS OF FOLLOWING P.C BOARD.

- SUB P.C BOARD
- FRONT P.C BOARD

## 3. MAIN P.C BOARD

Ref.No.	Part No.	Description
D1	*ED-511907	D SILICON 1N4002 100/1.0A
D2	*ED-511907	D SILICON 1N4002 100/1.0A
D3	*ED-511907	D SILICON 1N4002 100/1.0A
D4	*ED-511907	D SILICON 1N4002 100/1.0A
D5	ED-511907	D SILICON 1N4002 100/1.0A
D6	ED-511907	D SILICON 1N4002 100/1.0A
D7	*ED-346529	D ZENER H HZ6C2L
D8	*ED-346538	D ZENER H HZ9A2L

Ref.No.	Part No.	Description
D10	*ED-405446J	D ZENER H UTZJ5.6B T26
D11	ED-346559	D ZENER H HZ12B2L
D12	ED-346559	D ZENER H HZ12B2L
D13	*ED-346529	D ZENER H HZ6C2L
D14	*ED-405446J	D ZENER H UTZJ5.6B T26
D15	ED-346620	D ZENER H HZ27 2
D19	ED-400519J	D ZENER H MTZJ3.9A T26
D20	ED-307572	D SILICON H 1SS131
D21	ED-307572	D SILICON H 1SS131
D22	ED-307572	D SILICON H 1SS131
D23	ED-624903	D SILICON H 1S2473
D26	ED-307572	D SILICON H 1SS131
D27	ED-307572	D SILICON H 1SS131
D28	ED-307572	D SILICON H 1SS131
D29	ED-307572	D SILICON H 1SS131
D30	ED-403978J	D ZENER H UTZJ5.1B T26
D31	ED-403978J	D ZENER H UTZJ5.1B T26
D32	ED-624903	D SILICON H 1S2473
D33	ED-511907	D SILICON 1N4002 100/1.0A
D34	ED-511907	D SILICON 1N4002 100/1.0A
IC1	EI-408798J	IC M38173M6-143FP MXB1GE1
IC2	EI-387938J	IC HD74LS05P
IC3	EI-403308J	IC M50194P
IC4	EI-400756J	IC NJM4558L-B
IC5	EI-400756J	IC NJM4558L-B
IC6	EI-393323J	IC M5218AL-771
IC7	EI-393323J	IC M5218AL-771
IC8	EI-400756J	IC NJM4558L-B
IC9	EI-400756J	IC NJM4558L-B
IC10	EI-359053	IC LA3600
IC11	EI-200573	IC TC4053BP
IC12	EI-332259	IC TC4052BP
IC13	EI-302233	IC TC4051BP
IC14	EI-200573	IC TC4053BP
IC15	EI-200573	IC TC4053BP
IC16	EI-408646J	IC XR1091ECP
IC17	EI-408646J	IC XR1091ECP
IC18	EI-302233	IC TC4051BP
IC19	EI-302233	IC TC4051BP
IC20	EI-408393J	IC ST24C01B1
J1	EJ-404321J	SOCKET 52303-1510 WHITE 15P
L1	EO-345887	COIL FIX 1 EL0606SKI 221J
L2	EO-345887	COIL FIX 1 EL0606SKI 221J
L3	EO-345887	COIL FIX 1 EL0606SKI 221J
L4	EO-345887	COIL FIX 1 EL0606SKI 221J
R1	*ER-408267J	R OMF H S15 FS 2W 5R6J
R2	*ER-408267J	R OMF H S15 FS 2W 5R6J
R3	*ER-345751	R FUSE H S10 ERD2FC 1/4W 15R0G
R4	*ER-345751	R FUSE H S10 ERD2FC 1/4W 15R0G
R171	*ER-408267J	R OMF H S15 FS 2W 5R6J
R172	*ER-345751	R FUSE H S10 ERD2FC 1/4W 15R0G
TR1	*ET-366581	TR 2SD1762 E,F
TR2	*ET-397160J	TR 2SC3330 R,S,T,U,V
TR3	*ET-356817	TR 2SB891 Q,R
TR4	*ET-353899	TR 2SA1317 S,T,U
TR5	*ET-354083	TR 2SD1189 Q,R
TR6	ET-397160J	TR 2SC3330 R,S,T,U,V
TR7	*ET-356817	TR 2SB891 Q,R
TR8	ET-353899	TR 2SA1317 S,T,U
TR9	*ET-354083	TR 2SD1189 Q,R
TR10	*ET-397160J	TR 2SC3330 R,S,T,U,V
TR11	*ET-366365	TR 2SB1185 E,F
TR12	ET-353899	TR 2SA1317 S,T,U
TR15	ET-353899	TR 2SA1317 S,T,U
TR16	ET-397160J	TR 2SC3330 R,S,T,U,V
TR17	ET-397160J	TR 2SC3330 R,S,T,U,V
TR18	ET-354415	TR DTA144ES
TR19	ET-361736	TR 2SC3576
TR20	ET-361736	TR 2SC3576
TR21	ET-361736	TR 2SC3576
TR22	ET-361736	TR 2SC3576
TR23	ET-361736	TR 2SC3576
TR24	ET-354370	TR DTA124ES
TR25	ET-354370	TR DTA124ES
TR26	ET-354370	TR DTA124ES
TR28	ET-397160J	TR 2SC3330 R,S,T,U,V
TR29	ET-361736	TR 2SC3576
TR30	ET-361736	TR 2SC3576
TR31	ET-354415	TR DTA144ES
TR32	ET-354414	TR DTC144ES
X1	EI-405327J	OSC CE CST6.00MGW 6.000MHZ

#### 4. SUB P.C BOARD

Ref.No.	Part No.	Description
D201	ED-346538	D ZENER H HZ9A2L
D202	ED-346538	D ZENER H HZ9A2L
D203	ED-307572	D SILICON H 1SS131
D204	ED-307572	D SILICON H 1SS131
D205	ED-307572	D SILICON H 1SS131
D206	ED-307572	D SILICON H 1SS131
D207	ED-307572	D SILICON H 1SS131
D208	ED-307572	D SILICON H 1SS131
D209	ED-307572	D SILICON H 1SS131
D210	ED-403978J	D ZENER H UTZJ5.1B T26
IC201	EI-393323J	IC M5218AL-771
IC202	EI-408810J	IC M5289P-610
IC203	EI-408810J	IC M5289P-610
IC204	EI-408647J	IC LC7522
IC205	EI-400756J	IC NJM4558L-B
IC206	EI-332259	IC TC4052BP
IC207	EI-400756J	IC NJM4558L-B
IC208	EI-400756J	IC NJM4558L-B
R243	*ER-408806J	R OMF H S12 FS 1W 470J
R244	*ER-408806J	R OMF H S12 FS 1W 470J
SR201	EH-408801J	COMP R RGL7T 105J
SR202	EH-408801J	COMP R RGL7T 105J
TR201	ET-378524J	TR 2SC3383 S,T,U
TR202	ET-352726	TR 2SA1392 T,U

#### 5. FRONT P.C BOARD

Ref.No.	Part No.	Description
D301	ED-624903	D SILICON H 1S2473
D302	ED-624903	D SILICON H 1S2473
D303	ED-624903	D SILICON H 1S2473
D304	ED-624903	D SILICON H 1S2473
D305	ED-624903	D SILICON H 1S2473
D306	ED-511907	D SILICON 1N4002 100/1.0A
FL301	EM-408411J	IND FL BJ048GK DOUBLE
IC301	EI-408797J	IC M74HC154P
TR301	ET-396487J	TR DTA124XL T05
TR302	ET-396487J	TR DTA124XL T05
TR303	ET-396487J	TR DTA124XL T05
TR304	ET-396487J	TR DTA124XL T05
TR305	ET-396487J	TR DTA124XL T05
TR306	ET-396487J	TR DTA124XL T05
TR307	ET-396487J	TR DTA124XL T05
TR308	ET-396487J	TR DTA124XL T05
TR309	ET-396487J	TR DTA124XL T05
TR310	ET-396487J	TR DTA124XL T05
TR311	ET-396487J	TR DTA124XL T05
TR312	ET-396487J	TR DTA124XL T05
TS301	ES-394818J	SW TACT SOR-123HS T05
TS302	ES-394818J	SW TACT SOR-123HS T05
TS303	ES-394818J	SW TACT SOR-123HS T05
TS304	ES-394818J	SW TACT SOR-123HS T05
TS305	ES-394818J	SW TACT SOR-123HS T05
TS306	ES-394818J	SW TACT SOR-123HS T05
TS307	ES-394818J	SW TACT SOR-123HS T05
TS308	ES-394818J	SW TACT SOR-123HS T05
TS309	ES-394818J	SW TACT SOR-123HS T05
TS310	ES-394818J	SW TACT SOR-123HS T05

#### 6. FINAL ASSEMBLY

Ref.No.	Part No.	Description
1	SA-407840M	CUSHION FOOT REAR (SG)
2	ZS-394412M	BT BID30X08STL BZN PROJECTION
3	ZS-331182	BT BID30X08STL BNI
4A	SP-407967M	PANEL REAR EA-750 (U) (SG) [U]
4B	SP-407969M	PANEL REAR EA-750 (E) (SG) [E]
5	SP-407958J	PANEL FRONT-EA
6	SE-407963M	WINDOW FLD-EA (SG)
7	SE-407956M	ESCUTCHEON FRONT (SG)
8	SA-394136M	CUSHION FOOT (SG)
9	SM-409218J	NAME PLATE AKAI-S
10	ZW-408744J	PUSH NUT SPN-2
11	SB-407961M	BUTTON FR (SG)
12	SB-407962M	BUTTON OP (SG)
13	SB-407965M	BUTTON MEMO (SG)
14	SP-407980M	COVER UPPER-TP (SG)

#### NOTE:

Parts will not be supplied if they are not listed in the parts list, even if they appear on the assembling illustrations with reference No.



**FINAL ASSEMBLY**

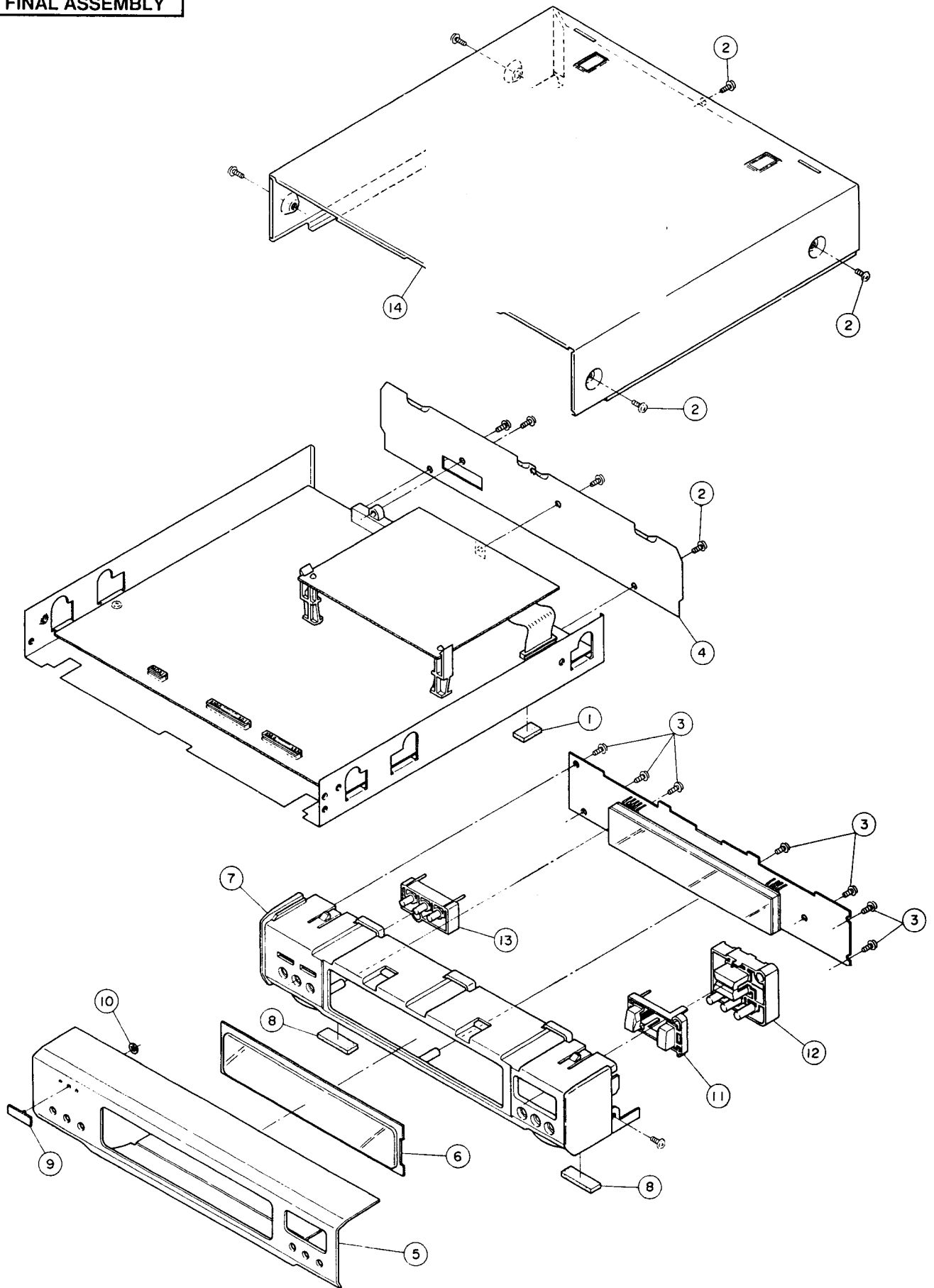

# INDEX

Part No.	Ref. No.	Part No.	Ref. No.	Part No.	Ref. No.	Part No.	Ref. No.
BAD3016T030A	2-1	EI403308J	3-IC3	ET396487J	5-TR312		
BAD3016T040A	2-2	EI405327J	3-X1	ET397160J	3-TR2		
ED307572	3-D20	EI408393J	3-IC20	ET397160J	3-TR6		
ED307572	3-D21	EI408646J	3-IC16	ET397160J	3-TR10		
ED307572	3-D22	EI408646J	3-IC17	ET397160J	3-TR16		
ED307572	3-D26	EI408647J	4-IC204	ET397160J	3-TR17		
ED307572	3-D27	EI408797J	5-IC301	ET397160J	3-TR28		
ED307572	3-D28	EI408798J	3-IC1	SA394136M	6-8		
ED307572	3-D29	EI408810J	4-IC202	SA407840M	6-1		
ED307572	4-D203	EI408810J	4-IC203	SB407961M	6-11		
ED307572	4-D204	EJ404321J	3-J1	SB407962M	6-12		
ED307572	4-D205	EM408411J	5-FL301	SB407965M	6-13		
ED307572	4-D206	EO345887	3-L1	SE407956M	6-7		
ED307572	4-D207	EO345887	3-L2	SE407963M	6-6		
ED307572	4-D208	EO345887	3-L3	SM409218J	6-9		
ED307572	4-D209	EO345887	3-L4	SP407958J	6-5		
ED346529	3-D7	ER345751	3-R3	SP407967M	6-4A		
ED346529	3-D8	ER345751	3-R4	SP407969M	6-4B		
ED346529	3-D13	ER345751	3-R172	SP407980M	6-14		
ED346538	4-D201	ER408267J	3-R1	ZS331182	6-3		
ED346538	4-D202	ER408267J	3-R2	ZS394412M	6-2		
ED346559	3-D11	ER408267J	3-R171	ZW408744J	6-10		
ED346559	3-D12	ER408806J	4-R243				
ED346620	3-D15	ER408806J	4-R244				
ED400519J	3-D19	ES394818J	5-TS301				
ED403978J	3-D30	ES394818J	5-TS302				
ED403978J	3-D31	ES394818J	5-TS303				
ED403978J	4-D210	ES394818J	5-TS304				
ED405446J	3-D9	ES394818J	5-TS305				
ED405446J	3-D10	ES394818J	5-TS306				
ED405446J	3-D14	ES394818J	5-TS307				
ED511907	3-D1	ES394818J	5-TS308				
ED511907	3-D2	ES394818J	5-TS309				
ED511907	3-D3	ES394818J	5-TS310				
ED511907	3-D4	ET352726	4-TR202				
ED511907	3-D5	ET353899	3-TR4				
ED511907	3-D6	ET353899	3-TR8				
ED511907	3-D33	ET353899	3-TR12				
ED511907	3-D34	ET353899	3-TR15				
ED511907	5-D306	ET354083	3-TR5				
ED624903	3-D23	ET354083	3-TR9				
ED624903	3-D32	ET354370	3-TR24				
ED624903	5-D301	ET354370	3-TR25				
ED624903	5-D302	ET354370	3-TR26				
ED624903	5-D303	ET354414	3-TR32				
ED624903	5-D304	ET354415	3-TR18				
ED624903	5-D305	ET354415	3-TR31				
EH408801J	4-SR201	ET356817	3-TR3				
EH408801J	4-SR202	ET356817	3-TR7				
EI200573	3-IC11	ET361736	3-TR19				
EI200573	3-IC14	ET361736	3-TR20				
EI200573	3-IC15	ET361736	3-TR21				
EI302233	3-IC13	ET361736	3-TR22				
EI302233	3-IC18	ET361736	3-TR23				
EI302233	3-IC19	ET361736	3-TR29				
EI332259	3-IC12	ET361736	3-TR30				
EI332259	4-IC206	ET366365	3-TR11				
EI359053	3-IC10	ET366581	3-TR1				
EI382875J	3-X2	ET378524J	4-TR201				
EI387938J	3-IC2	ET396487J	5-TR301				
EI393323J	3-IC6	ET396487J	5-TR302				
EI393323J	3-IC7	ET396487J	5-TR303				
EI393323J	4-IC201	ET396487J	5-TR304				
EI400756J	3-IC4	ET396487J	5-TR305				
EI400756J	3-IC5	ET396487J	5-TR306				
EI400756J	3-IC8	ET396487J	5-TR307				
EI400756J	3-IC9	ET396487J	5-TR308				
EI400756J	4-IC205	ET396487J	5-TR309				
EI400756J	4-IC207	ET396487J	5-TR310				
EI400756J	4-IC208	ET396487J	5-TR311				

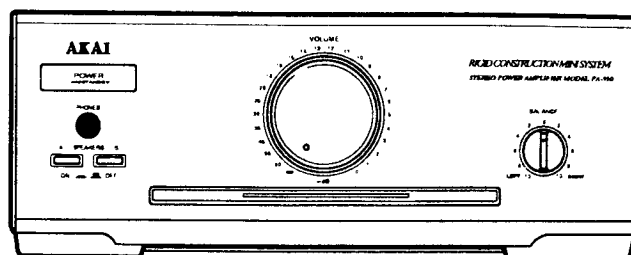

**MODEL PA-950**

**STEREO POWER AMPLIFIER**

**MODEL PA-750, 950**

**SPECIFICATIONS**

**Power output**

**MODEL PA-750**

FTC .....	45W + 45W (60Hz to 20kHz, 0.5% THD, 6 ohms)
DIN .....	55W + 55W (1kHz, 1.0% THD, 6 ohms)
	50W + 50W (1kHz, 1.0% THD, 8 ohms)
EIAJ .....	70W + 70W (1kHz, 10% THD, 6 ohms)

**MODEL PA-950**

FTC .....	55W + 55W (60Hz to 20kHz, 0.5% THD, 6 ohms)
DIN .....	65W + 65W (1kHz, 1.0% THD, 6 ohms)
	55W + 55W (1kHz, 1.0% THD, 8 ohms)
EIAJ .....	85W + 85W (1kHz, 10% THD, 6 ohms)

**Music power output**

MODEL PA-750 .....	500W (L / R total)
MODEL PA-950 .....	600W (L / R total)

**Peak music power output**

MODEL PA-750 .....	800W (L / R total)
MODEL PA-950 .....	900W (L / R total)

**Required speaker impedance .....**

6 to 16 ohms (A or B)  
12 to 16 ohms (A + B)

**Power requirement .....**

AC220 - 230V, 50Hz for Europe except UK  
AC240V, 50Hz for UK and Australia  
AC110/120/220/240V, 50/60Hz convertible for other countries.

**Power consumption**

MODEL PA-750 .....	110W
MODEL PA-950 .....	130W

**Dimensions .....**

270(W) X 100(H) X 358(D) mm

**Weights**

MODEL PA-750 .....	5.6kg
MODEL PA-950 .....	6.2kg

**Standard accessories**

Remote control unit .....	X1
Batteries .....	X2
Operator's manual .....	X1

\* For improvement purposes, specifications and design are subject to change without notice.

# I. DISASSEMBLY

In case of trouble, etc., necessitating dismantling, please dismantle in the order shown in the illustrations. Reassemble in the reverse order.

## 1. Removal of the UPPER COVER

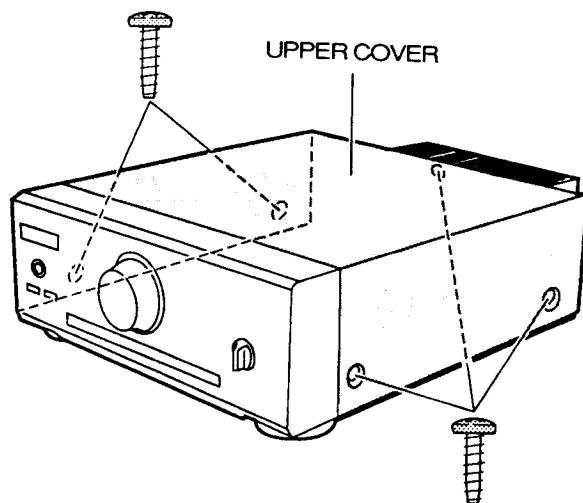

## 2. Removal of the FRONT PANEL

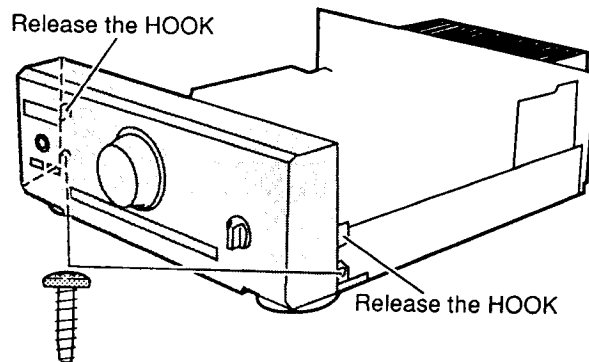
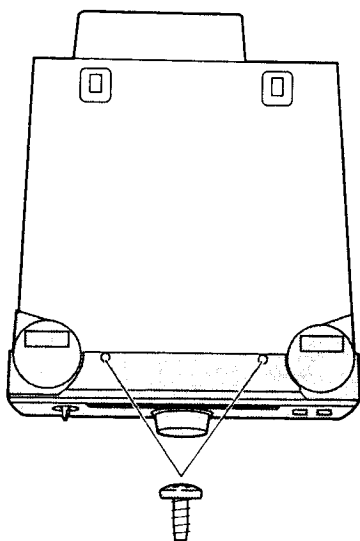

## II. PRINCIPAL PARTS LOCATION

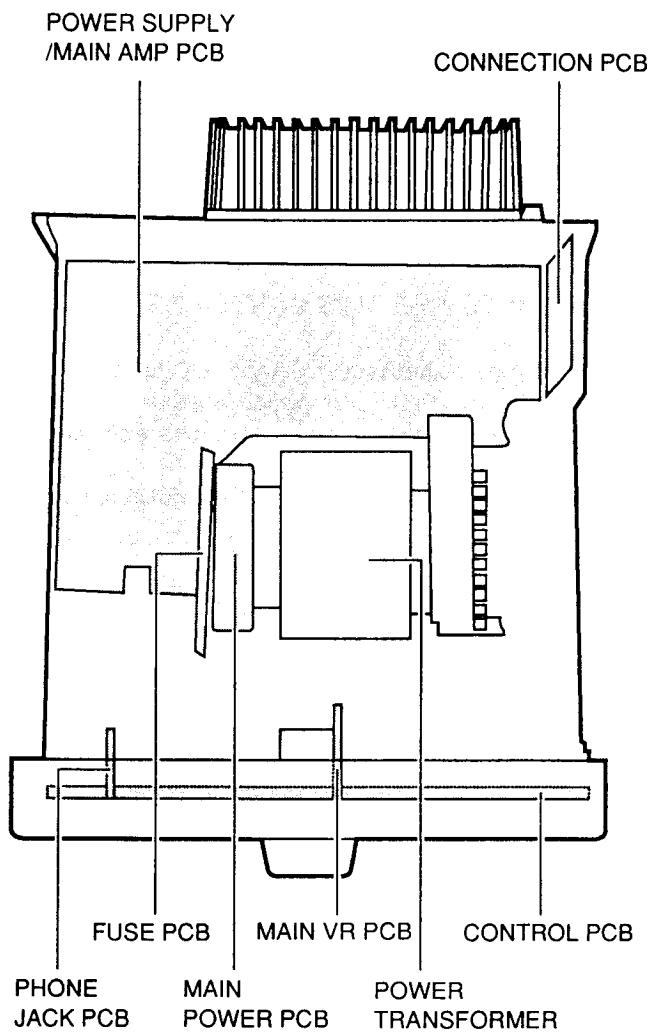

Fig.2-1 Top view

# III. PARTS LIST

## ATTENTION

1. When placing an order for parts, be sure to list Part No., Model No. and the description of each part. Otherwise, the non-delivery of the part or the delivery of a wrong part may result.
2. Please make sure that Part No. is correct when ordering. If not, a part different from the one you ordered may be delivered.
3. Since the parts shown in Parts List of Preliminary Service Manual may have been the subject of changes, please use this Parts List for all future reference.

## HOW TO USE THIS PARTS LIST

1. This Parts List lists those parts which are considered necessary for repairs. Other common parts, such as resistors and capacitors, are listed in the "Common List for Service Parts" from which these parts should be selected and stocked.
2. The Recommended Spare Parts List shows those parts in the Parts List which are considered particularly important for service.
3. Parts not shown in the Parts List and "Common List for Service Parts" will not in principle be supplied.
4. How to read the Parts List.

a) Mechanism Block

b) PC Board

### 2. HEAD BASE BLOCK

### 6. MAIN PC BOARD

Ref. No.	Part No.	Description
1	BH-T2023A320A	HEAD BASE BLOCK
2	HP-H2206A010A	HEAD R/P PR4-8FU C
3	ZS-477876	PAN20×03STL CMT
4	ZS-536488	BID20×08STL CMT
5	ZG-402895	SP CS ANGLE ADJUST

Ref. No.	Part No.	Description
IC1	EI-324536	IC HD14049BP
IC2	EI-336801	IC MB8841-564M
C1A	EC-338399	C MMY V 223M 250AC [U,E,B,S]
C1B	EC-350949	C MMY V 223M 250DC [J]
C1C	EC-338397	C MMY V 223M 125AC [C,A]
X1	EI-318384	OSC X'TAL NC-18C

SP (Service Parts) Classification

This number corresponds with the individual parts index number in that figure.

Symbols for primary destination

[A] : AAL (U.S.A) [S] : SAA (Australia)  
 [B] : BEAB (England) [U] : U/T (Universal Area)  
 [C] : CSA (Canada)  
 [E] : CEE (Europe) [V] : VDE (Germany)  
 [J] : JPN (Japan) [Y] : Custom Version

SP (Service Parts) Classification

These reference symbols correspond with component symbols in the Schematic Diagrams.

The available PC Board Blocks are listed separately.

5. When Part No. is known, Parts Index at end of Parts List can be used to locate where that part is shown in Parts List by its Reference No. listed at right of Part No.

## WARNING

⚠ (\*) INDICATES SAFETY CRITICAL COMPONENTS. FOR CONTINUED SAFETY, REPLACE SAFETY CRITICAL COMPONENTS ONLY WITH MANUFACTURE'S RECOMMENDED PARTS.

## AVERTISSEMENT

⚠ (\*) IL INDIQUE LES COMPOSANTS CRITIQUES DE SÉCURITÉ. POUR MAINTENIR LE DEGRÉ DE SÉCURITÉ DE L'APPAREIL, NE REMPLACER QUE DES PIÈCES RECOMMANDÉES PAR LE FABRICANT.

## 1. RECOMMENDED SPARE PARTS

We suggest you to stock the following Recommended Spare Part items listed below since they can cover most of the routine service.

Ref.No.	Part No.	Description
1	AX-408738M	REMOCON RC-S650
2	*BT-408786M	TRANS POW A5013 B S [B,S] [750]
3	*BT-408785M	TRANS POW A5013 E V [E,V] [750]
4	*BT-408784M	TRANS POW A5013 U [U] [750]
5	*BT-408789M	TRANS POW A5014 B S [B,S] [950]
6	*BT-408788M	TRANS POW A5014 E V [E,V] [950]
7	*BT-408787M	TRANS POW A5014 U [U] [950]
8	ED-394509J	D LED GL3HY43 ORANGE
9	ED-408768J	D LED SEL2213C TP6 RED
10	ED-408640J	D LED SEL2913KTP6 D ORANGE T05
11	ED-307572	D SILICON H 1SS131
12	*ED-394708J	D SILICON RBA402 200/4.0A [750]
13	*ED-384278J	D SILICON RBV602 200/6.0A [950]
14	*ED-511907	D SILICON 1N4002 100/1.0A
15	ED-388320J	D ZENER H HZS12B3L
16	*ED-378530J	D ZENER H HZS6B2L
17	*EF-355398	FUSE BET T 250V 2.00A [U,B,S]
18	*EF-364518	FUSE BET T 250V 2.50A [750]
19	*EF-359225	FUSE BET T 250V 3.15A [950]
20	*EF-359086	FUSE BET T 250V 4.00A
21	*EF-358974	FUSE BET T 250V 630MA
22	*EF-601964	FUSE SEMKO T 250V 1.60A [750]
23	*EI-358554	IC STK4152II [750]
24	*EI-366695	IC STK4172-2 [950]
25	EO-337880	COIL FIX 2 202AK-018 2R2K
26	*EO-338409	COIL LF FKOB160MH02 250UH
27	*ER-331188	R FUSE H S10 ERD2FC 1/4W 8R2J
28	*ER-401039J	R FUSE V T05 ERD2FCV 1/4W 4R7J
29	*ER-408716J	R FUSE V T05 ERD2FCV 1/4W56R0G
30	ER-397193J	R OMF V T05 FS 1W 100J
31	ES-394512J	SW PUSH SPEA12 02-02N
32	*ES-349070	SW SELECTOR YKS11-0002 02-4
33	ES-408703J	SW TACT EVQ 233 05R T05
34	ET-369248	TR DTA114YS
35	ET-373985	TR DTA144TS
36	ET-354365	TR DTC114YS
37	ET-354371	TR DTC124ES
38	ET-353899	TR 2SA1317 S,T,U
39	*ET-366365	TR 2SB1185 E,F
40	ET-397160J	TR 2SC3330 R,S,T,U,V
41	*ET-378524J	TR 2SC3383 S,T,U
42	ET-394735J	TR 2SC3792 T05
43	*ET-366581	TR 2SD1762 E,F
44	EV-408707J	VR ROTARY RK11K1140 SP W104 [BALANCE VR]
45	EV-408811J	VR SPL RK16EUWMZ1 B104X2 [MAIN VR]

## 2. P.C BOARD BLK

Ref.No.	Part No.	Description
1A	BA-A5013T030A	ML PC (#) MAIN BLK PA-750 (U) /ML
1B	BA-A5013T030B	ML PC (#) MAIN BLK PA-750 (E) /ML
1C	BA-A5013T030C	ML PC (#) MAIN BLK PA-750 (V) /ML
1D	BA-A5013T030D	ML PC (#) MAIN BLK PA-750 (B) /ML
1E	BA-A5013T030E	ML PC (#) MAIN BLK PA-950 (U) /ML

Ref.No.	Part No.	Description
1G	BA-A5013T030G	ML PC (#) MAIN BLK PA-950 (V) /ML
1H	BA-A5013T030H	ML PC (#) MAIN BLK PA-950 (B) /ML

PC (#) MAIN BLK CONSISTS OF FOLLOWING P.C BOARD.

- POWER SUPPLY/MAIN AMP P.C BOARD
- CONNECTION P.C BOARD
- CONTROL P.C BOARD
- MAIN VR P.C BOARD
- PHONE JACK P.C BOARD
- INDICATOR P.C BOARD
- FUSE P.C BOARD

## 3. POWER SUPPLY/MAIN AMP P.C BOARD

Ref.No.	Part No.	Description
C83A	EC-394535J	C EC V CUT SME 332M 45.0DC [750]
C83B	EC-394534J	C EC V CUT SME 472M 50.0DC [950]
C84A	EC-394535J	C EC V CUT SME 332M 45.0DC [750]
C84B	EC-394534J	C EC V CUT SME 472M 50.0DC [950]
C91	*EC-403337J	C CE V DE7100 F472M 400AC
C92	*EC-403337J	C CE V DE7100 F472M 400AC
D1A	*ED-394708J	D SILICON RBA402 200/4.0A [750]
D1B	*ED-384278J	D SILICON RBV602 200/6.0A [950]
D2	*ED-511907	D SILICON 1N4002 100/1.0A
D3	*ED-511907	D SILICON 1N4002 100/1.0A
D4	ED-388320J	D ZENER H HZS12B3L
D5	ED-307572	D SILICON H 1SS131
D6	ED-307572	D SILICON H 1SS131
D7	ED-307572	D SILICON H 1SS131
D8	ED-307572	D SILICON H 1SS131
D9	ED-307572	D SILICON H 1SS131
D10	*ED-388320J	D ZENER H HZS12B3L
D11	*ED-511907	D SILICON 1N4002 100/1.0A
D12	*ED-511907	D SILICON 1N4002 100/1.0A
D13	*ED-388320J	D ZENER H HZS12B3L
D14	ED-511907	D SILICON 1N4002 100/1.0A
D15	ED-511907	D SILICON 1N4002 100/1.0A
D16	ED-511907	D SILICON 1N4002 100/1.0A
D17	ED-511907	D SILICON 1N4002 100/1.0A
D18	*ED-511907	D SILICON 1N4002 100/1.0A
FR1	*ER-331188	R FUSE H S10 ERD2FC 1/4W 8R2J
FR2	*ER-408716J	R FUSE V T05 ERD2FCV 1/4W56R0G
FR3	*ER-401039J	R FUSE V T05 ERD2FCV 1/4W 4R7J
IC1A	*EI-358554	IC STK4152II [750]
IC1B	*EI-366695	IC STK4172-2 [950]
L1	EO-337880	COIL FIX 2 202AK-018 2R2K
L2	EO-337880	COIL FIX 2 202AK-018 2R2K
L3	EO-342936	COIL BALUM [V]
L4	EO-342936	COIL BALUM [V]
L5	*EO-338409	COIL LF FKOB160MH02 250UH
R9	ER-397193J	R OMF V T05 FS 1W 100J
R10	ER-397193J	R OMF V T05 FS 1W 100J
R59	ER-397193J	R OMF V T05 FS 1W 100J
R60	ER-397193J	R OMF V T05 FS 1W 100J
TM1	EJ-408698J	TERMINAL PUSH LQR0810-0006 8P
TR1	ET-354365	TR DTC114YS
TR2	ET-373985	TR DTA144TS
TR3	*ET-366365	TR 2SB1185 E,F
TR4	ET-353899	TR 2SA1317 S,T,U
TR5	ET-369248	TR DTA114YS
TR6	*ET-353899	TR 2SA1317 S,T,U
F1A	*EF-364518	FUSE BET T 250V 2.50A [750]
F1B	*EF-359225	FUSE BET T 250V 3.15A [950]
F2A	*EF-364518	FUSE BET T 250V 2.50A

Ref.No.	Part No.	Description
F2B	*EF-359225	FUSE BET T 250V 3.15A [950]
F3	*EF-355398	FUSE BET T 250V 2.00A [U,B,S]
F4	*EF-355398	FUSE BET T 250V 2.00A [U]

#### 4. CONECTION P.C BOARD

Ref.No.	Part No.	Description
D201	*ED-511907	D SILICON 1N4002 100/1.0A
D202	*ED-511907	D SILICON 1N4002 100/1.0A
D203	*ED-378530J	D ZENER H HZS6B2L
D204	*ED-388320J	D ZENER H HZS12B3L
D205	*ED-307572	D SILICON H 1SS131
J6	EJ-408717J	SOCKET CFG1115-0121 RED 15P
J7	EJ-408775J	SOCKET CFG1204-0101 BLACK 4P
TR201	*ET-366581	TR 2SD1762 E,F
TR202	*ET-378524J	TR 2SC3383 S,T,U

#### 5. CONTROL P.C BOARD

Ref.No.	Part No.	Description
D301	ED-408768J	D LED SEL2213C TP6 RED
D302	ED-408768J	D LED SEL2213C TP6 RED
D303	ED-408768J	D LED SEL2213C TP6 RED
D304	ED-408768J	D LED SEL2213C TP6 RED
D305	ED-408640J	D LED SEL2913KTP6 D ORANGE T05
D306	ED-408640J	D LED SEL2913KTP6 D ORANGE T05
D307	ED-408640J	D LED SEL2913KTP6 D ORANGE T05
D308	ED-408640J	D LED SEL2913KTP6 D ORANGE T05
D309	ED-408640J	D LED SEL2913KTP6 D ORANGE T05
R313	ER-397194J	R OMF V T05 FS 1W 331J
R314	ER-397194J	R OMF V T05 FS 1W 331J
SW301	ES-394512J	SW PUSH SPEA12 02-02N
SW302	ES-394512J	SW PUSH SPEA12 02-02N
TR301	ET-353899	TR 2SA1317 S,T,U
TR302	ET-353899	TR 2SA1317 S,T,U
TR303	ET-397160J	TR 2SC3330 R,S,T,U,V
TR304	ET-397160J	TR 2SC3330 R,S,T,U,V
TR305	ET-354371	TR DTC124ES
TR306	ET-354371	TR DTC124ES
TR307	ET-354371	TR DTC124ES
TR308	ET-354371	TR DTC124ES
TR309	ET-394735J	TR 2SC3792 T05
TR310	ET-394735J	TR 2SC3792 T05
TS301	ES-408703J	SW TACT EVQ 233 05R T05
VR301	EV-408707J	VR ROTARY RK11K1140 SP W104 [BALANCE VR]

#### 6. MAIN VR P.C BOARD

Ref.No.	Part No.	Description
VR401	EV-408811J	VR SPL RK16EUWMZ1 B104X2 [MAIN VR]

#### 7. PHONE JACK P.C BOARD

Ref.No.	Part No.	Description
J501	EJ-390079J	PHONE J 3P YKB21-5009A NI 6.3

#### 8. INDICATOR P.C BOARD

Ref.No.	Part No.	Description
D601	ED-394509J	D LED GL3HY43 ORANGE

#### 9. FUSE P.C BOARD

Ref.No.	Part No.	Description
F701A	*EF-601964	FUSE SEMKO T 250V 1.60A [750]
F701B	*EF-355398	FUSE BET T 250V 2.00A [950]
F702A	*EF-601964	FUSE SEMKO T 250V 1.60A [750]
F702B	*EF-355398	FUSE BET T 250V 2.00A [950]
F703	*EF-358974	FUSE BET T 250V 630MA
F704	*EF-358974	FUSE BET T 250V 630MA
F705	*EF-359086	FUSE BET T 250V 4.00A
F706	*EF-359086	FUSE BET T 250V 4.00A

#### 10. FINAL ASSEMBLY

Ref.No.	Part No.	Description
1	SA-407840M	CUSHION FOOT REAR (SG)
2A	SP-408079M	PANEL REAR PA- (1) (SG) [U]
2B	SP-408080M	PANEL REAR PA- (2) (SG) [E,V,B,S]
3	ZS-331182	BT BID30X08STL BNI
4	ZS-394412M	BT BID30X08STL BZN PROJECTION
5	ZS-725336J	BT BID30X16STL BNI
6	*ES-349070	SW SELECTOR YKS11-0002 02-4
7A	SP-408063J1	PANEL FRONT-A [750]
7B	SP-408072J1	PANEL FRONT-B [950]
8	SE-408064M1	ESCUTCHEON FRONT (SG)
9	SA-394136M	CUSHION FOOT (SG)
10	SM-409218J	NAME PLATE AKAI-S
11	ZW-408744J	PUSH NUT SPN-2
12	SB-408066M	BUTTON POWER (SG)
13	SE-408069M	LENS INDICATOR (1) (SG)
14	SE-408070M	LENS INDICATOR (2) (SG)
15	SE-408067M	BUTTON SP (SG)
16	ZS-407886M	BT PAN30X08STL BZN C100 (SG)
17	SE-407867M	LENS VR (SG)
18	SK-407864M	KNOB VR (SG)
19	SK-407865M	KNOB BALANCE (SG)
20A	*BT-408784M	TRANS POW A5013 U [U] [750]
20B	*BT-408785M	TRANS POW A5013 E V [E,V] [750]
20C	*BT-408786M	TRANS POW A5013 B S [B,S] [750]
20D	*BT-408787M	TRANS POW A5014 U [U] [950]
20E	*BT-408788M	TRANS POW A5014 E V [E,V] [950]
20F	*BT-408789M	TRANS POW A5014 B S [B,S] [950]
21	ZS-346742	ST BID40X08STL CMT CUP
22A	*EW-408790M	AC CORD200 SZ4W H03VVH2F B120 U [U]
22B	*EW-404002M	AC CORD 200 SE-1 WITH TUBE E [E,V]
22C	*EW-404001M	AC CORD 200 VCTFK WITH TUBE B [B]
22D	*EW-404003M	AC CORD 200 SA-2 WITH TUBE S [S]
23	SP-408065M	COVER UPPER PA (SG)

#### 11. ACCESSARY

Ref.No.	Part No.	Description
1	AX-408738M	REMOCON RC-S650



**FINAL ASSEMBLY**

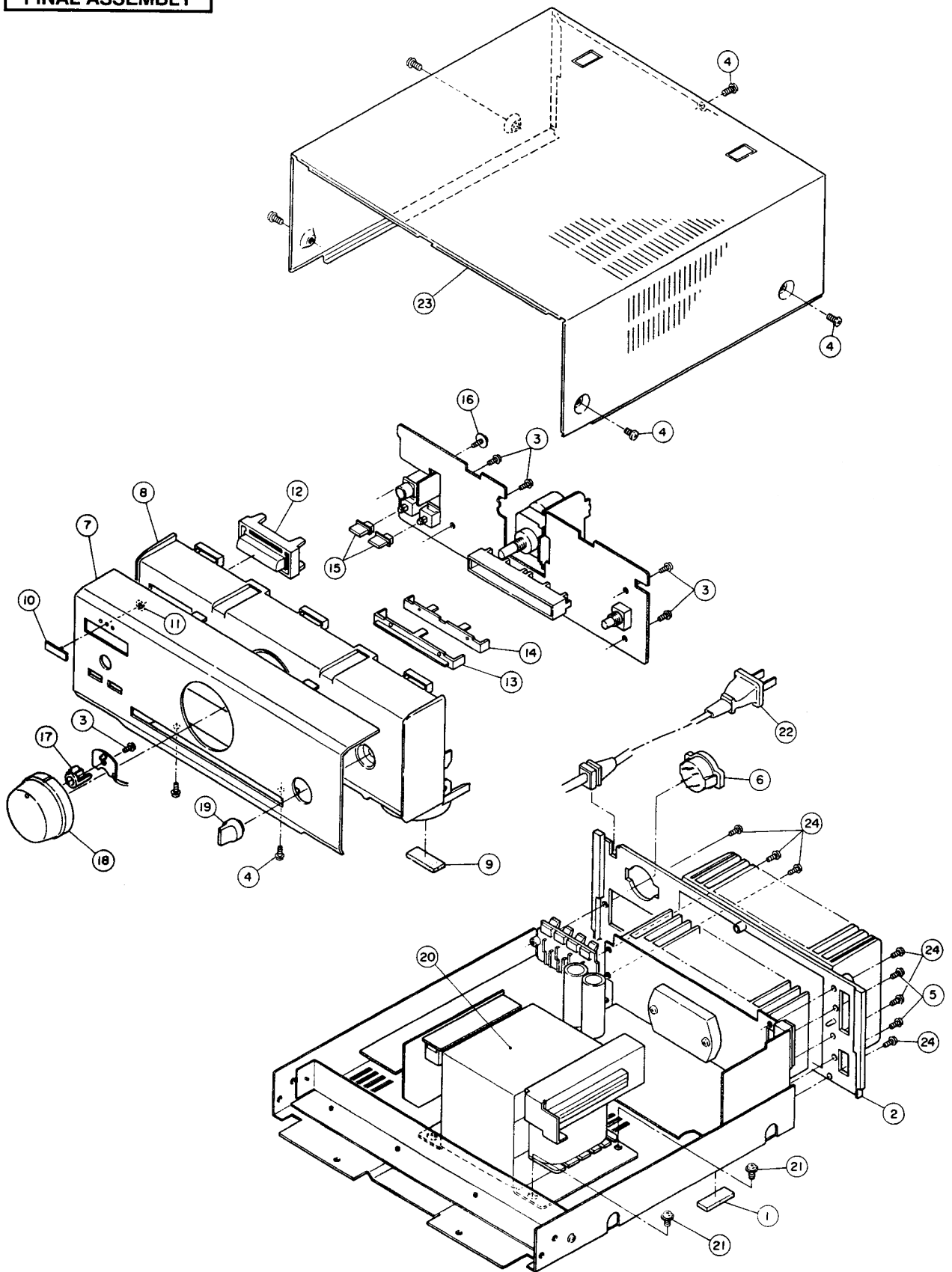

**NOTE:**

Parts will not be supplied if they are not listed in the parts list, even if they appear on the assembling illustrations

# INDEX

Part No.	Ref. No.	Part No.	Ref. No.	Part No.	Ref. No.	Part No.	Ref. No.
AX408738M	11-1	EI366695	3-IC1B				
BAA5013T030A	2-1A	EJ390079J	7-J501				
BAA5013T030B	2-1B	EJ408698J	3-TM1				
BAA5013T030C	2-1C	EJ408717J	4-J6				
BAA5013T030D	2-1D	EJ408775J	4-J7				
BAA5013T030E	2-1E	EO337880	3-L1				
BAA5013T030F	2-1F	EO337880	3-L2				
BAA5013T030G	2-1G	EO338409	3-L5				
BAA5013T030H	2-1H	EO342936	3-L3				
BT408784M	10-20A	EO342936	3-L4				
BT408785M	10-20B	ER331188	3-FR1				
BT408786M	10-20C	ER397193J	3-R9				
BT408787M	10-20D	ER397193J	3-R10				
BT408788M	10-20E	ER397193J	3-R59				
BT408789M	10-20F	ER397193J	3-R60				
EC394534J	3-C83B	ER397194J	5-R313				
EC394534J	3-C84B	ER397194J	5-R314				
EC394535J	3-C83A	ER401039J	3-FR3				
EC394535J	3-C84A	ER408716J	3-FR2				
EC403337J	3-C91	ES349070	10-6				
EC403337J	3-C92	ES394512J	5-SW301				
ED307572	3-D5	ES394512J	5-SW302				
ED307572	3-D6	ES408703J	5-TS301				
ED307572	3-D7	ET353899	3-TR4				
ED307572	3-D8	ET353899	3-TR6				
ED307572	3-D9	ET353899	5-TR301				
ED307572	4-D205	ET353899	5-TR302				
ED378530J	4-D203	ET354365	3-TR1				
ED384278J	3-D1B	ET354371	5-TR305				
ED388320J	3-D4	ET354371	5-TR306				
ED388320J	3-D10	ET354371	5-TR307				
ED388320J	3-D13	ET354371	5-TR308				
ED388320J	4-D204	ET366365	3-TR3				
ED394509J	8-D601	ET366581	4-TR201				
ED394708J	3-D1A	ET369248	3-TR5				
ED408640J	5-D305	ET373985	3-TR2				
ED408640J	5-D306	ET378524J	4-TR202				
ED408640J	5-D307	ET394735J	5-TR309				
ED408640J	5-D308	ET394735J	5-TR310				
ED408640J	5-D309	ET397160J	5-TR303				
ED408768J	5-D301	ET397160J	5-TR304				
ED408768J	5-D302	EV408707J	5-VR301				
ED408768J	5-D303	EV408811J	6-VR401				
ED408768J	5-D304	EW404001M	10-22C				
ED511907	3-D2	EW404002M	10-22B				
ED511907	3-D3	EW404003M	10-22D				
ED511907	3-D11	EW408790M	10-22A				
ED511907	3-D12	SA394136M	10-9				
ED511907	3-D14	SA407840M	10-1				
ED511907	3-D15	SB408066M	10-12				
ED511907	3-D16	SE407867M	10-17				
ED511907	3-D17	SE408064M1	10-8				
ED511907	3-D18	SE408067M	10-15				
ED511907	4-D201	SE408069M	10-13				
ED511907	4-D202	SE408070M	10-14				
EF355398	3-F3	SK407864M	10-18				
EF355398	3-F4	SK407865M	10-19				
EF355398	9-F701B	SM409218J	10-10				
EF355398	9-F702B	SP408063J1	10-7A				
EF358974	9-F703	SP408065M	10-23				
EF358974	9-F704	SP408072J1	10-7B				
EF359086	9-F705	SP408079M	10-2A				
EF359086	9-F706	SP408080M	10-2B				
EF359225	3-F1B	ZS331182	10-3				
EF359225	3-F2B	ZS346742	10-21				
EF364518	3-F1A	ZS394412M	10-4				
EF364518	3-F2A	ZS407886M	10-16				
EF601964	9-F701A	ZS425336J	10-5				
EF601964	9-F702A	ZW408744J	10-11				
EI358554	3-IC1A						

## ABBREVIATIONS (AMPLIFIER)

ABBREVIATION	EXPLANATION
A	Analog
AC	Alternating Current
AMP	AMPlifier
CD	Compact Disc
COM	COMmon
D	Digital
D/A	Digital to Analog
DAC	Digital to Analog Converter
DAT	Digital Audio Tape recorder
DC	Direct Current
GND	GrouND
L	Left
LED	Light Emitting Diode
MC	Moving Coil
MM	Moving Magnet
PCB	Printed Circuit Board
R	Right
REG	REGulator
REC	RECord
TR	TRansistor
SW	SWitch
V.AMP	Voltage AMPlifier
VCR	Video Cassette Recorder
V.DIS	Video DISC
VR	Variable Resistor
VTR	Video Tape Recorder

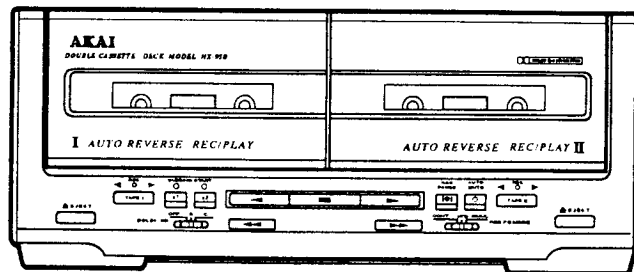

**MODEL HX-950**

**STEREO CASSETTE DECK**

**MODEL HX-750, 950**

**SPECIFICATIONS**

Track system .....	4 track 2 channel system
Wow & Flutter .....	0.09% (WRMS), 0.15% (DIN)
Frequency response .....	Normal 35Hz to 14,000Hz ( $\pm 3$ dB) CrO <sub>2</sub> 35Hz to 15,000Hz ( $\pm 3$ dB) Metal 35Hz to 15,000Hz ( $\pm 3$ dB) (HX-950 only)
S/N ratio .....	76dB (Dolby C ON, 1kHz to 10kHz) 66dB (Dolby B ON, 5kHz) 56dB (Dolby OFF, CrO <sub>2</sub> tape)
Total harmonic distortion .....	Less than 0.3% (Normal tape, at 315Hz)
Channel separation .....	35dB (Normal tape)
Power consumption	
MODEL HX-750 .....	15W
MODEL HX-950 .....	15W
Dimensions .....	270 (W) X 110 (H) X 301 (D)mm
Weights	
MODEL HX-750 .....	2.6kg
MODEL HX-950 .....	2.8kg

\* For improvement purposes, specifications and design are subject to change without notice.

\* Noise reduction manufactured under license from Dolby Laboratories Licensing Corporation.

"DOLBY" and  symbol are trademarks of Dolby Licensing Corporation.

HX-750 950

# I. DISASSEMBLY

In case of trouble, etc., necessitating dismantling, please dismantle in the order shown in the illustrations. Reassemble in the reverse order.

1. Removal of the UPPER COVER

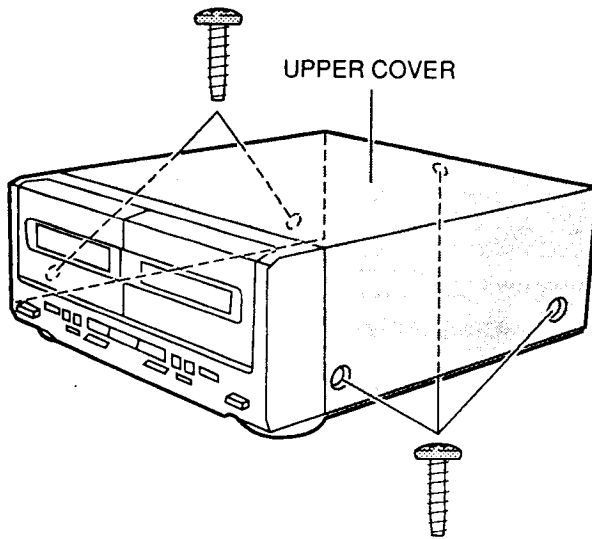

3.

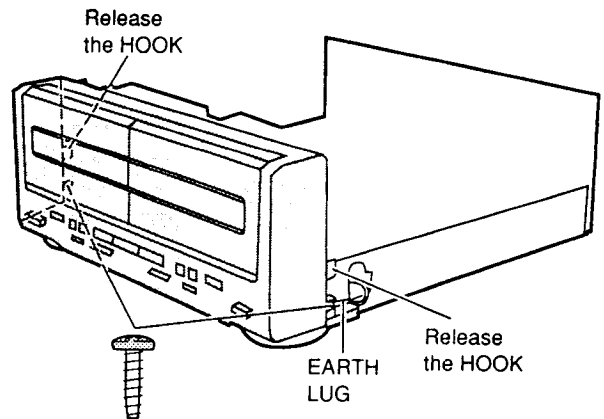

2. Removal of the FRONT PANEL BLOCK

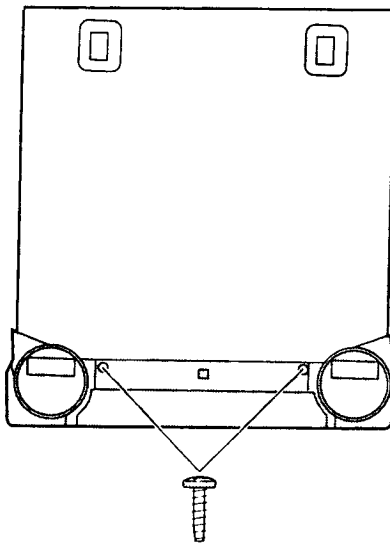

4. Removal of the MECHA. BLOCK

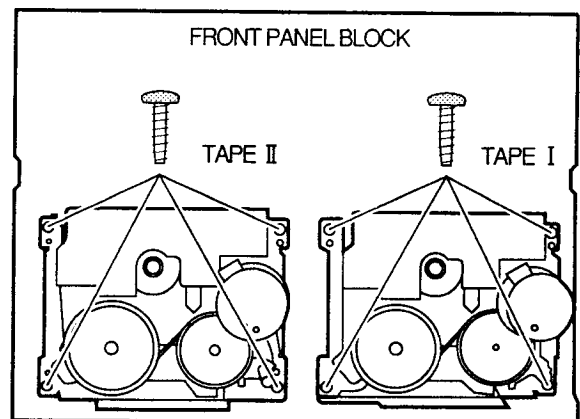

## II. PRINCIPAL PARTS LOCATION

---

### 2-1. MODEL HX-750

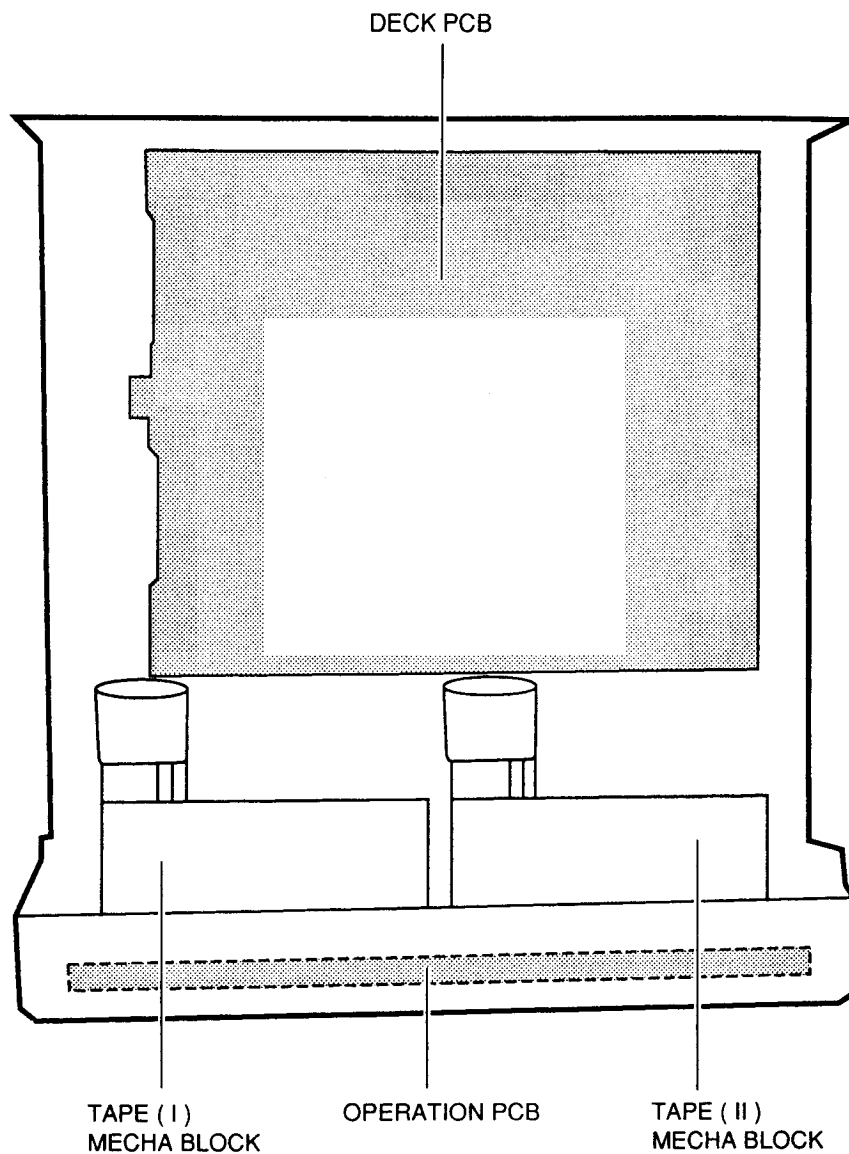

Fig.2-1 Top view

2-2. MODEL HX-950

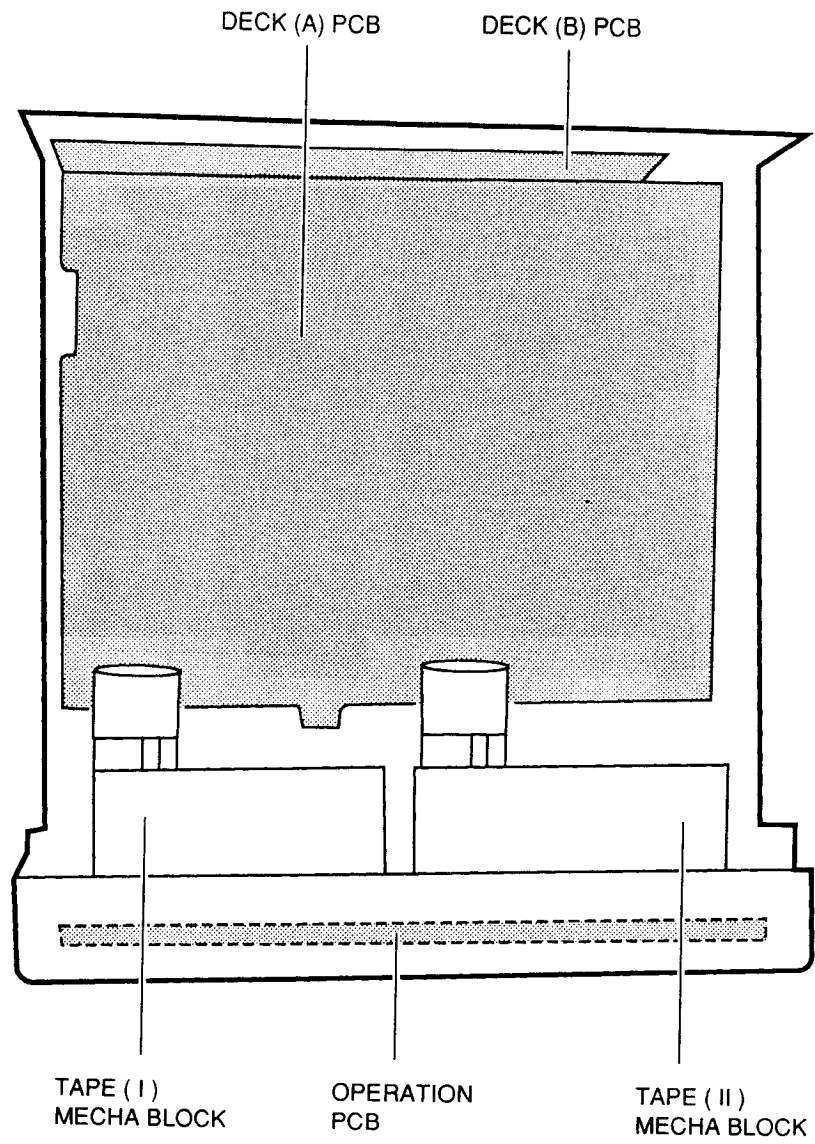

Fig.2-2 Top view

# III. REPLACEMENT OF PRINCIPAL MECHANICAL PARTS

## 3-1. REPLACEMENT OF THE PINCH ROLLER BLOCK

- 1) Pull the PINCH ROLLER BLOCK upward (↑) while releasing the PINCH ROLLER RETAINING HOOK.
- 2) Reassemble in the reverse order.

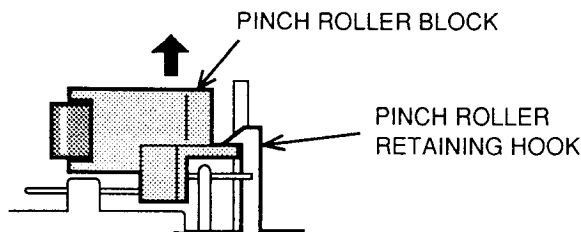

Fig.3-1

## 3-2. REPLACEMENT OF THE PB HEAD (model HX-750 TAPE I only)

- 1) Remove the two HEAD RETAINING (A) SCREWS.
- 2) Pull out the HEAD and disconnect all the lead wires with a soldering iron, then replace the PB HEAD.
- 3) Reassemble in the reverse order. After replacement, head azimuth and PB level adjustment must be performed.

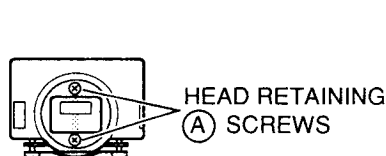

Fig.3-2

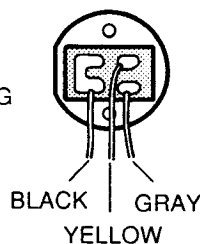
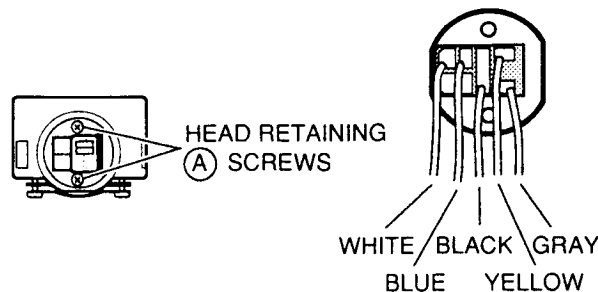

Fig.3-3

## 3-3. REPLACEMENT OF THE REC/PB HEAD (Except model HX-750 TAPE I)

- 1) Remove the two HEAD RETAINING (A) SCREWS.
- 2) Pull out the HEAD and disconnect all lead wires with a soldering iron, then replace the REC/PB HEAD.
- 3) Reassemble in the reverse order. After replacement, head azimuth, PB level, BIAS current and REC level adjustments must be performed.



## 3-4. REPLACEMENT OF THE CAPSTAN MOTOR

- 1) Disconnect the lead wire of the CAPSTAN MOTOR with a soldering iron.
- 2) Remove the CAPSTAN MOTOR RETAINING (B) SCREWS, then replace the CAPSTAN MOTOR.
- 3) Reassemble in the reverse order and set the DRIVE BELT. After replacement, tape speed adjustment must be performed.

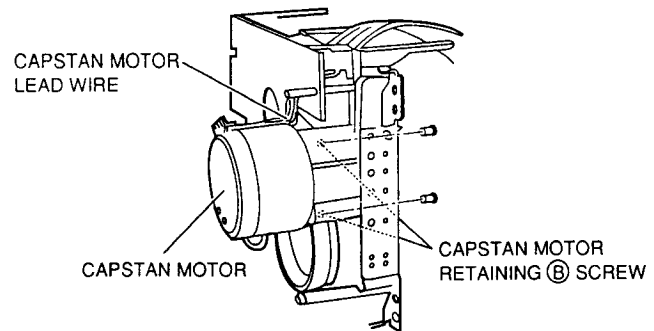
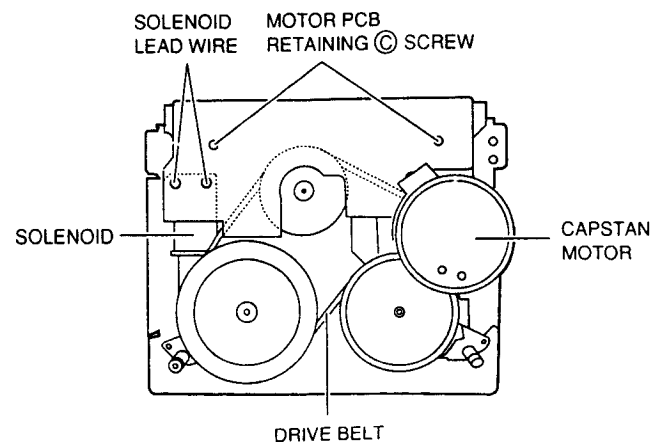

Fig.3-6

## 3-5. REPLACEMENT OF THE DRIVE BELT

- 1) Remove the CAPSTAN MOTOR RETAINING (B) SCREWS. (refer illustration Fig.3-6)
- 2) Unsolder the lead wires of the SOLENOID with a soldering iron.
- 3) Remove the two MOTOR PCB RETAINING (C) SCREWS and separate the MOTOR PCB from the MECHA BLK. Replace the DRIVE BELT.
- 4) Reassemble in the reverse order. After replacement, confirm the tape speed and if the result is not satisfactory, adjust the tape speed.





# IV. MECHANICAL ADJUSTMENT

## 4-1. ADJUSTMENT OF THE PB HEAD AZIMUTH ALIGNMENT (model HX-750 TAPE I only)

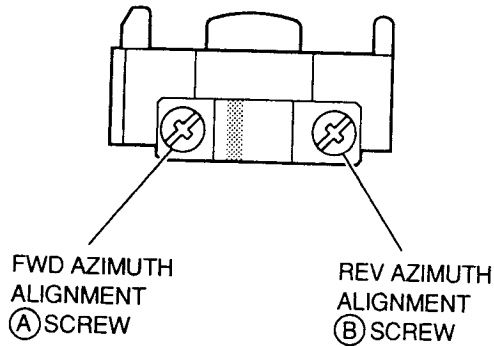

Fig.4-1

- 1) Connect an AC milli-voltmeter to the TP-750 VCR REC OUT L and R-CH then connect an oscilloscope's input CH-1 and CH-2 to the output of the AC milli-voltmeters.
- 2) Play back the 10 kHz (-15 dB), HEAD AZIMUTH ALIGNMENT TEST TAPE (TF-106CH) then adjust the PB HEAD AZIMUTH ALIGNMENT (A) (FWD PLAY) and (B) (REV PLAY) SCREW respectively so that the reading on the AC mill-voltmeters are at maximum and waveforms on the oscilloscope are in the same phase, in both FWD and REV directions.

## 4-2. ADJUSTMENT OF THE REC/PB HEAD AZIMUTH ALIGNMENT (Except HX-750 TAPE I)

- 1) Connect an AC milli-voltmeter to the TP-750 VCR REC OUT L and R-CH then connect the oscilloscope's input CH-1 and CH-2 to the output of the AC milli-voltmeters.
- 2) Play back the 10 kHz (-15dB), HEAD AZIMUTH ALIGNMENT TEST TAPE (TF-106CH) then adjust the REC/PB HEAD AZIMUTH ALIGNMENT (A) (FWD PLAY) and (B) (REV PLAY) SCREW respectively so that the reading on the AC milli-voltmeters are at maximum and waveforms on the oscilloscope are in the same phase in both FWD and REV directions.

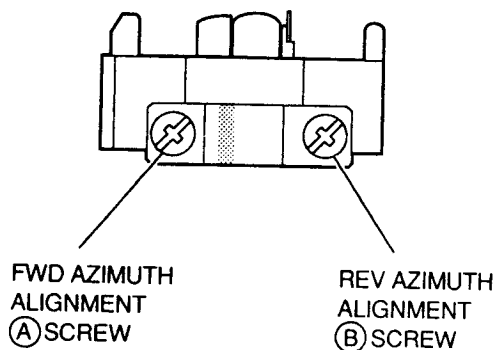

Fig.4-2

# ELECTRICAL ADJUSTMENT

MODEL HX-750

Following adjustment should be performed in test mode.

Engage the test mode, connect the AC power to the AC outlet while pressing the **▶▶** and **▶** buttons together.

When the test mode is engaged, X1 dub lamp is lit.

When performing the tape speed adjustment, observe the following notes.

Adjustment should be started more than 30 seconds after the power is ON.

Adjustment should be made on X2 speed mode when adjust normal speed mode.

Adjustment should be made in the forward direction.

## TAPE I (X2) TAPE SPEED

Use 315 Hz test tape (TF-110CT)

Press the x 2 DUBBING START button) VCR REC OUT, VR651

Select a frequency counter to the VCR REC OUT.

Adjustment range:  $\pm 20$  Hz

## TAPE I NORMAL TAPE SPEED

Use 315 Hz test tape (TF-110CT)

VCR REC OUT, VR653

Select a frequency counter to the VCR REC OUT.

Adjustment range:  $\pm 10$  Hz

## TAPE II (X2) TAPE SPEED

Use 315 Hz test tape (TF-110CT)

Press the x 2 DUBBING START button) VCR REC OUT, VR654

Select a frequency counter to the VCR REC OUT.

Adjustment range:  $\pm 20$  Hz

## TAPE II NORMAL TAPE SPEED

Use 315 Hz test tape (TF-110CT)

VCR REC OUT, VR652

Select a frequency counter to the VCR REC OUT.

Adjustment range:  $\pm 10$  Hz

### STEP ADJUSTMENT

1. TEST TAPE/INPUT SIGNAL
2. MODE
3. CHECK POINT, ADJUSTMENT PART
4. REMARKS (●) and RESULT (\*)

Adjustment Part

Test Point

(0 dBs = 0.775V)

### 6 TAPE II PB LEVEL

1. 315 Hz test tape (TF-101CL)
2. PLAY
3. VCR REC OUT, VR102 (L-ch) / VR152 (R-ch)
4. ● Connect an AC milli-voltmeter to the VCR REC OUT.  
\* -10 dBs

### 5 TAPE I PB LEVEL

1. 315 Hz test tape (TF-101CL)
2. PLAY
3. VCR REC OUT, VR101 (L-ch) / VR151 (Rch)
4. ● Connect an AC milli-voltmeter to the VCR REC OUT.  
\* -10 dBs

### 9 RECORDING LEVEL

1. 1 kHz, -10 dBs (VCR REC OUT) / NORMAL recording test tape (UD-124)
2. REC → PLAY
3. VCR REC OUT, VR351 (L-ch) / VR301 (R-ch)
4. ● Connect an AC Milli-voltmeter to the VCR REC OUT.  
● Connect an audio signal generator to the AUX INPUT and set the generator level so that the VCR REC OUT levels are -10 dBs.  
\* Playback levels after recording are -10 dBs

### 8 NORMAL POSITION BIAS

1. 1 kHz and 10 kHz, -30 dBs (VCR REC OUT) / NORMAL recording test tape (UD-124).
2. REC → PLAY
3. VCR REC OUT, VR402 (L-ch) / VR403 (R-ch)
4. ● Connect an AC Milli-voltmeter to the VCR REC OUT.  
● Connect an audio signal generator to the AUX INPUT and set the generator level so that the VCR REC OUT levels are -30 dBs.  
\* Playback level difference between 1 kHz and 10 kHz after recording is within  $\pm 0.2$  dB.

### 7 BIAS OSC FREQUENCY

1. CrO<sub>2</sub> type blank tape
2. REC
3. TAPE II, T401 (P102)
4. ● Connect a frequency counter between P102 ⑤ pin and GND.  
\* 100.0  $\pm$  0.2 kHz

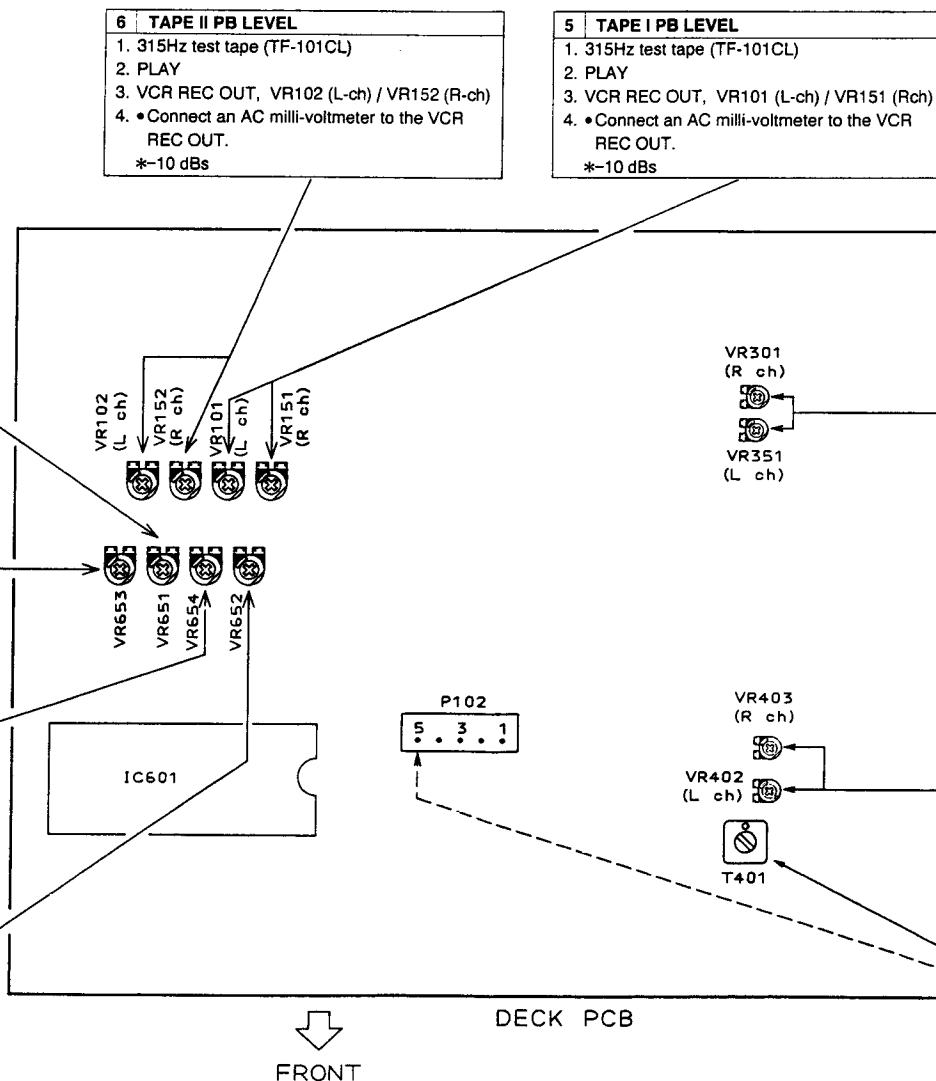

FRONT

DECK PCB

SERVICE MANUAL

HX-750, 950

Following adjustment should be performed in the order indicated.

1. To adjust the test mode, connect the AC power to the AC outlet while pressing the **▶▶** and **▶** buttons together.

2. When the test mode is engaged, X1 dub lamp is lit.

3. When performing the tape speed adjustment, observe the following notes.

4. The adjustment should be started more than 30 seconds after the power is ON.

5. The adjustment should be made on X 2 speed mode first and then on just normal speed mode.

6. The adjustment should be made in the forward direction.

**ADJUSTMENT POINT**

**ADJUSTMENT PART**

Adjustment Part

Test Point

VR301, VR351, VR401, VR451, VR502, VR552, VR101, VR152, VR151, VR102, VR702, VR701, VR704, VR703, T951, T952, T901, T902, VR951, VR952, VR901, VR902, P101, P102, R906, IC701

**OSC FREQUENCY**

recording test tape (AC-712)

pin, T501 (TAPE I)

pin, T551 (TAPE II)

Connect a frequency counter between P101 and GND, P102 @pin and GND.

$\pm 0.2\text{kHz}$

**DC VOLTAGE POINT**

recording test tape (AC-712)

pin, T901, T902 (TAPE I)

pin, T951, T952 (TAPE II)

Connect a digital voltmeter both end of the test mode.

Level of DC range.

**METAL POSITION BIAS**

1. 1kHz and 10kHz, -30dBs (VCR REC OUT) METAL recording test tape (UD-124).

2. REC → PLAY

3. VCR REC OUT, VR901 (TAPE I L-ch) / VR951 (TAPE I R-ch) and VR951 (TAPE I L-ch) / VR952 (TAPE II R-ch)

4. •Connect an AC Milli-voltmeter to the VCR REC OUT.

•Connect an audio signal generator to the AUX INPUT and set the generator level so that the VCR REC OUT levels are -30dBs.

\*Playback level difference between 1kHz and 10kHz is within  $\pm 0.2\text{dB}$ .

**11 METAL POSITION BIAS**

1. 1kHz and 10kHz, -30 dBs (VCR REC OUT) METAL recording test tape (AC-712)

2. REC → PLAY

3. VCR REC OUT, VR502 (TAPE I) / VR552 (TAPE II)

4. •Connect an AC Milli-voltmeter to the VCR REC OUT.

•Connect an audio signal generator to the AUX INPUT and set the generator level so that the VCR REC OUT levels are -30 dBs.

\*Playback levels difference between 1kHz and 10kHz is within 0.2dB.

**10 RECORDING LEVEL**

1. 1 kHz, -10 dBs (VCR REC OUT) / NORMAL recording test tape (UD-124)

2. REC → PLAY

3. VCR REC OUT, VR301 (TAPE I L-ch) / VR351 (TAPE I R-ch) and VR401 (TAPE II L-ch) / VR451 (TAPE II R-ch).

4. •Connect an AC Milli-voltmeter to the VCR REC OUT.

•Connect an audio signal generator to the AUX INPUT and set the generator level so that the VCR REC OUT levels are -10 dBs.

\*Playback levels after recording are -10 dBs

**5 TAPE I PB LEVEL**

1. 315Hz test tape (TF-101CL)

2. PLAY

3. VCR REC OUT, VR101 (L-ch) / VR151 (R-ch)

4. •Connect an AC milli-voltmeter to the VCR REC OUT.

\*-10dBs

**6 TAPE II PB LEVEL**

1. 315Hz test tape (TF-101CL)

2. PLAY

3. VCR REC OUT, VR102 (L-ch) / VR152 (R-ch)

4. •Connect an AC milli-voltmeter to the VCR REC OUT.

\*-10dBs

**1 TAPE I (X2) TAPE SPEED**

1. 3,150Hz test tape (TF-110CT)

2. PLAY

3. VCR REC OUT, VR701

4. •Connect a frequency counter to the VCR REC OUT.

\*6,300  $\pm$  20Hz

**2 TAPE I NORMAL TAPE SPEED**

1. 3,150Hz test tape (TF-110CT)

2. PLAY

3. VCR REC OUT, VR702

4. •Connect a frequency counter to the VCR REC OUT.

\*3,150  $\pm$  10Hz

**3 TAPE II (X2) TAPE SPEED**

1. 3,150Hz test tape (TF-110CT)

2. PLAY

3. VCR REC OUT, VR703

4. •Connect a frequency counter to the VCR REC OUT.

\*6,300  $\pm$  20Hz

**4 TAPE II NORMAL TAPE SPEED**

1. 3,150Hz test tape (TF-110CT)

2. PLAY

3. VCR REC OUT, VR704

4. •Connect a frequency counter to the VCR REC OUT.

\*3,150  $\pm$  10Hz

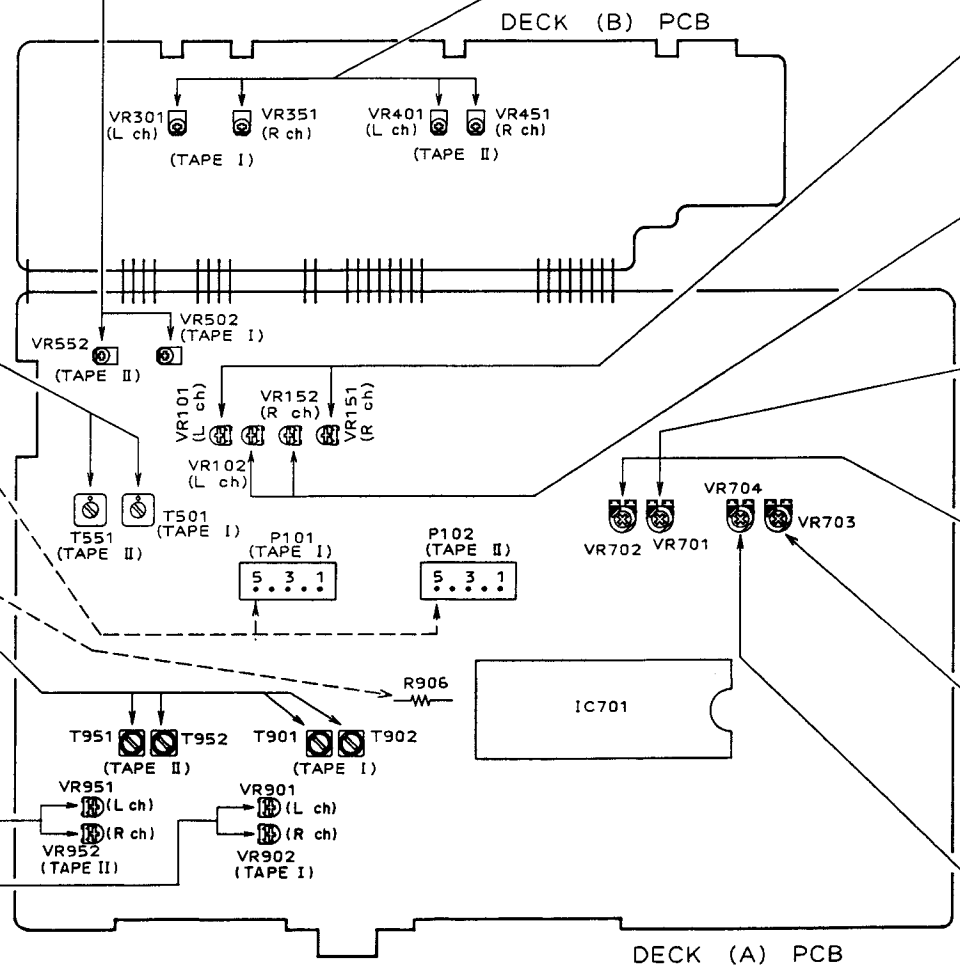

# VI. PARTS LIST

## ATTENTION

1. When placing an order for parts, be sure to list Part No., Model No. and the description of each part. Otherwise, the non-delivery of the part or the delivery of a wrong part may result.
2. Please make sure that Part No. is correct when ordering. If not, a part different from the one you ordered may be delivered.
3. Since the parts shown in Parts List of Preliminary Service Manual may have been the subject of changes, please use this Parts List for all future reference.

## HOW TO USE THIS PARTS LIST

1. This Parts List lists those parts which are considered necessary for repairs. Other common parts, such as resistors and capacitors, are listed in the "Common List for Service Parts" from which these parts should be selected and stocked.
2. The Recommended Spare Parts List shows those parts in the Parts List which are considered particularly important for service.
3. Parts not shown in the Parts List and "Common List for Service Parts" will not in principle be supplied.
4. How to read the Parts List.

### a) Mechanism Block

#### 2. HEAD BASE BLOCK

Ref. No.	Part No.	Description
1	BH-T2023A320A	HEAD BASE BLOCK
2	HP-H2206A010A	HEAD R/P PR4-8FU C
3	ZS-477876	PAN20×03STL CMT
4	ZS-536488	BID20×08STL CMT
5	ZG-402895	SP CS ANGLE ADJUST

SP (Service Parts) Classification

This number corresponds with the individual parts index number in that figure.

### b) PC Board

#### 6. MAIN PC BOARD

Ref. No.	Part No.	Description
IC1	EI-324536	IC HD14049BP
IC2	EI-336801	IC MB8841-564M
C1A	EC-338399	C MMY V 223M 250AC [U,E,B,S]
C1B	EC-350949	C MMY V 223M 250DC [J]
C1C	EC-338397	C MMY V 223M 125AC [C,A]
X1	EI-318384	OSC X'TAL NC-18C

Symbols for primary destination

[A] : AAL (U.S.A)      [S] : SAA (Australia)  
 [B] : BEAB (England) [U] : U/T (Universal Area)  
 [C] : CSA (Canada)  
 [E] : CEE (Europe)    [V] : VDE (Germany)  
 [J] : JPN (Japan)      [Y] : Custom Version

SP (Service Parts) Classification

These reference symbols correspond with component symbols in the Schematic Diagrams.

The available PC Board Blocks are listed separately.

5. When Part No. is known, Parts Index at end of Parts List can be used to locate where that part is shown in Parts List by its Reference No. listed at right of Part No.

## WARNING

⚠ (\*) INDICATES SAFETY CRITICAL COMPONENTS. FOR CONTINUED SAFETY, REPLACE SAFETY CRITICAL COMPONENTS ONLY WITH MANUFACTURE'S RECOMMENDED PARTS.

## AVERTISSEMENT

⚠ (\*) IL INDIQUE LES COMPOSANTS CRITIQUES DE SÉCURITÉ. POUR MAINTENIR LE DEGRÉ DE SÉCURITÉ DE L'APPAREIL, NE REMPLACER QUE DES PIÈCES RECOMMANDÉES PAR LE FABRICANT.

## 1. RECOMMENDED SPARE PARTS

We suggest you to stock the following Recommended Spare Part items listed below since they can cover most of the routine service.

Ref.No.	Part No.	Description
1	BB-408782M1	MECHA GAK9302 [750 TAPE-1]
2	BB-408781M1	MECHA GAK9602 [950 TAPE-2]
3	BB-408783M1	MECHA GAK9603 [950 TAPE-1]
4	BB-410525M1	MECHA GAK9604 [750 TAPE-2]
5	BM-729992J	MOTOR EG-530KD-2B [OLD]
6	BM-729993J	MOTOR EG-530YD-2B [NEW]
7	ED-394509J	D LED GL3HY43 ORANGE
8	ED-394724J	D LED GL3PR43 RED [950]
9	ED-408651J	D LED SEL2913K ORANGE [750]
10	ED-307572	D SILICON H 1SS131
11	*ED-511907	D SILICON 1N4002 100/1.0A
12	*ED-408743J	D ZENER H HZS11B3L
13	ED-404319J	D ZENER H HZS12B2L
14	*ED-388320J	D ZENER H HZS12B3L
15	ED-391003J	D ZENER H HZS4C3
16	ED-408733J	D ZENER H HZS6A3L
17	*ED-400171J	D ZENER H HZS6C2L
18	EH-408820J	COMP R RGL10T 472J
19	EH-408821J	COMP R RGL12T 473J
20	EH-387619J	COMP R RGL14X 103J
21	EH-404318J	COMP R RGL5X 332J
22	EH-389421J	COMP R RGL7X 103J
23	EH-408713J	COMP R RGL8T 332J
24	EI-394573J	IC CXA1331S
25	EI-387938J	IC HD74LS05P
26	EI-394574J	IC LA2000
27	EI-337008	IC LC7800
28	EI-393323J	IC M5218AL-771
29	EI-394569J	IC M66312P
30	EI-310036	IC TC4066BP
31	EI-373383	IC UPC1297CA
32	EI-408700J1	IC UPD75108CW-W19 MXA1DK2
33	EI-410610J	IC UPD75108CW-W20 MXB1DK1
34	EI-373957J1	OSC CE CST4.19MGW 4.194MHZ
35	EO-408699J	COIL OSC 1 T2134 100.0KHZ
36	EO-408762J	COIL OSC 1 T2135-1 100.0KHZ
37	EO-408763J	COIL OSC 1 T2135-2 (HX) 100.0KHZ
38	EO-356809	COIL TUN 1 100Z-121 100.00KHZ
39	EP-733165J	SOLENOID ASSY
40	*ER-200926	R FUSE H S10 ERD2FC 1/4W 27R0G
41	ES-733164J	LEAF SWITCH LSA-1114G
42	ES-733163J	LEAF SWITCH LSA-1141EAU
43	ES-408708J	SW SLIDE SSSS91 L=2 1-01-03
44	ES-408641J	SW TACT EVQ 233 07K T05
45	ET-733156J	DETECTOR NJL5165K
46	ET-369248	TR DTA114YS
47	ET-373382	TR DTA143ZS
48	ET-373985	TR DTA144TS
49	ET-360399	TR DTC114TS
50	ET-354365	TR DTC114YS
51	ET-373485	TR DTC123JS
52	ET-375986	TR DTC124TS
53	ET-354364	TR DTC143TS
54	ET-373391	TR DTC143ZS
55	ET-354414	TR DTC144ES
56	ET-370310	TR DTC144TS
57	ET-408777J	TR FET 2SJ40 D,E T05
58	ET-408709J	TR FET 2SK373 Y,GR T05
59	*ET-348302	TR FET 2SK381 C,D F05
60	ET-353899	TR 2SA1317 S,T,U
61	ET-408772J	TR 2SA1318 S,T,U T05
62	ET-397160J	TR 2SC3330 R,S,T,U,V
63	ET-361736	TR 2SC3576
64	ET-400741J	TR 2SC3708 T T05
65	*ET-366581	TR 2SD1762 E,F

Ref.No.	Part No.	Description
67	ET-396072J	TR 2SD2159 V,W
68	EV-330531	R S-FIX H TM8KV2-1S 0.50W503
69	EV-404299J	R S-FIX H T05 KVSF637T 0.1W332
70	EV-394561J	R S-FIX H V8K4-11 (1S) 0.10W102
71	EV-367524	R S-FIX H V8K4-11 (1S) 0.10W501
72	EV-403967J	R S-FIX V T05EVNDCAA03 0.1W332
73	EW-733169J	5P HEAD WIRE ASSY
74	EW-733168J	3P HEAD WIRE ASSY
75	HP-733172J	ROTATION HEAD MK10P-AB2N3
76	HR-733173J	ROTATION HEAD YK56R-AA4N3
77	HZ-733119J	TAPE GUIDE
78	MB-733130J	DRIVE BELT (A)
79	MR-733129J	P ROLLER
80	MZ-733132J	HOUSING ASSY (L)
81	MZ-733131J	HOUSING ASSY (R)

## 2. MECHA BLK

Ref.No.	Part No.	Description
2	ZG-733087J	PACK SPRING
3	ML-733088J	SHIFT LEVER
5	HZ-733090J	HEAD PLATE ASSY
6	ZG-733091J	AZIMUTH SPRING
12	MZ-733096J	COLLAR
13	MS-733097J	PINCH ROLLER ARM SHAFT
21	MZ-733104J	CLUTCH GEAR
22	MZ-733105J	REW GEAR
23	ML-733106J	ER ARM
24	MZ-733107J	FR GEAR
25	MZ-733108J	REEL GEAR
26	MT-733109J	REEL CAP (A)
27	MT-733110J	REEL BUSH (B)
28	ML-733111J	PLAY ARM
32	ML-733115J	SHIFT LEVER SELECT
33	MZ-733116J	PLAY CAM GEAR
34	ML-733117J	TRIGGER ARM
35	ML-733118J	SELECT ARM
36	HZ-733119J	TAPE GUIDE
37	MZ-733120J	ROTATION GEAR
38	MZ-733121J	RETURN GEAR
39	MS-733122J	CASSETTE GUIDE
40	ML-733123J	P ROLLER ARM (R)
41	ML-733124J	P ROLLER ARM (L)
42	ML-733125J	BRAKE ARM
45	MR-733128J	MOTOR PULLEY
46	MR-733129J	P ROLLER
47	MB-733130J	DRIVE BELT (A)
48	MZ-733131J	HOUSING ASSY (R)
49	MZ-733132J	HOUSING ASSY (L)
50	ZG-733133J	RETURN SPRING
51	ZG-733134J	REEL SPRING
53	ZG-733136J	CLUTCH ARM SPRING
55	ZG-733138J	PLAY ARM SPRING
56	ZG-733139J	SHIFT LEVER SELECT SPRING
57	ZG-733140J	TRIGGER ARM SPRING
58	ZG-733141J	SHIFT SPRING
59	ZG-733142J	HEAD CHASSIS SPRING
60	ZG-733143J	P ROLLER ARM (R) SPRING
61	ZG-733144J	P ROLLER ARM (L) SPRING
62	ZG-733145J	BRAKE ARM SPRING
63A	ZG-733146J	INTER LOCK LEVER (R) SPRING [GAK9602][GAK9604]
63B	ZG-733147J	INTER LOCK LEVER (L) SPRING [GAK9603][GAK9302]
65	ZW-733149J	POLYSLIDER WASHER 1.6X3X0.13T
66	SZ-733150J	REFLECT SEAL
68	ZG-733152J	AZIMUTH SCREW
70	ZG-733154J	HEAD SCREW (RVS)
72	ET-733156J	DETECTOR NJL5165K
73	ER-341091	R CB H F05 RDS 1/6W 152J
74	ZW-733157J	POLYSLIDER WASHER 1.8X6X0.5T
75	ZW-733158J	POLYSLIDER WASHER 2.3X4X0.25T
76	ZW-733159J	TEFRON WASHER 4.1X6.5X0.25T
77	ZW-733160J	POLYSLIDER WASHER 3.5X6.5X0.5T
78	ZW-733161J	POLYSLIDER WASHER 2.1X4X0.25T
79	ZW-733162J	POLYSLIDER WASHER 1.65X5X0.5T
80	ES-733163J	LEAF SWITCH LSA-1141EAU
81	ES-733164J	LEAF SWITCH LSA-1114G

A BLK

Part No.	Description
EW-733167J	15P FLAT RIBBON WIRE
EW-733168J	3P HEAD WIRE ASSY [PB]
EW-733169J	5P HEAD WIRE ASSY [REC/PB]
EJ-733170J	CONNECTOR 52004-1510
BM-729992J	MOTOR EG-530KD-2B [OLD]
BM-729993J	MOTOR EG-530YD-2B [NEW]
HP-733172J	ROTATION HEAD MK10P-AB2N3 [GAK9302 ONLY]
HR-733173J	ROTATION HEAD YK56R-AA4N3
CS-460440	PAN20X04STL CMT
CS-321320	BT PAN20X06STL CMT
CS-733174J	TAPPING SCREW 1.7X8
CS-432843	PAN26X04STL CMT
CS-733175J	WASHER HEAD SCREW 20X6
MA-733176J	MECHA BASE ASSY
Z-733179J	PLAY GEAR ASSY
MF-733191J	FLYWHEEL (R) ASSY
MF-733192J	FLYWHEEL (L) ASSY
Z-733194J	CLUTCH ASSY
C-322028	C CE V F05 SL 101J 50DC

Not to be supplied if they are not listed in the parts list  
if they appear on the assembling illustrations  
Reference No.

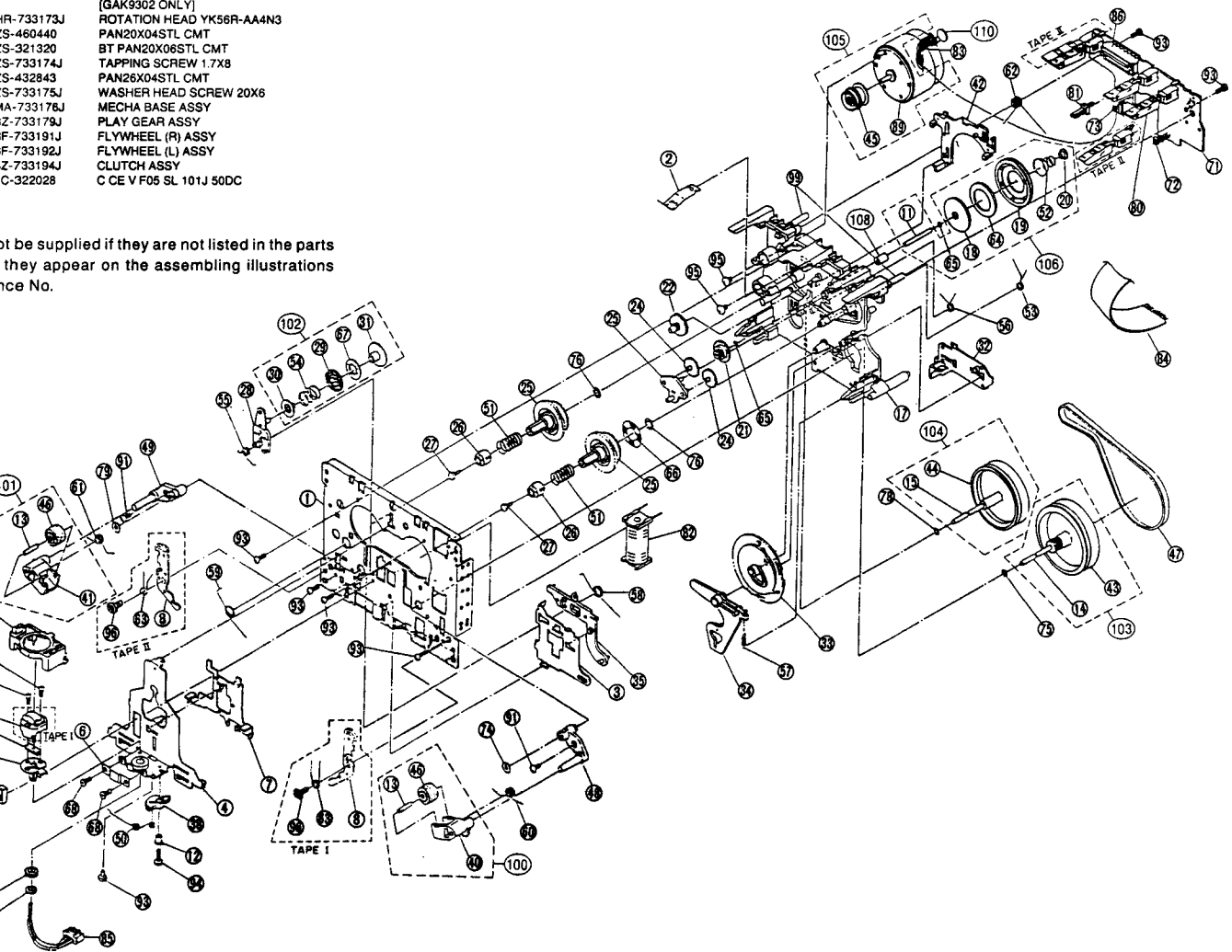

PARTS LIST

### 3. P.C BOARD BLK

Ref.No.	Part No.	Description
1A	BA-T2134T070A	ML PC—DECK-750 BLK HX-750/ML
1B	BA-T2135T070A	ML PC—DECK-950 BLK HX-950/ML
PC (#) DECK-750 BLK CONSISTS OF FOLLOWING P.C BOARD.		
• DECK P.C BOARD		
• OPERATION P.C BOARD		
PC (#) DECK-950 BLK CONSISTS OF FOLLOWING P.C BOARD.		
• DECK (A) P.C BOARD		
• DECK (B) P.C BOARD		
• OPERATION P.C BOARD		
TR302	ET-354364	TR DTC143TS
TR303	ET-354364	TR DTC143TS
TR304	ET-354364	TR DTC143TS
TR305	ET-408777J	TR FET 25J40 D,E T05
TR351	ET-397180J	TR 25C3330 R,S,T,U,V
TR352	ET-354364	TR DTC143TS
TR353	ET-354364	TR DTC143TS
TR354	ET-354364	TR DTC143TS
TR355	ET-408777J	TR FET 25J40 D,E T05
TR381	ET-369248	TR DTA114YS
TR401	ET-354414	TR DTC144ES
TR402	ET-354414	TR DTC144ES
TR403	ET-397180J	TR 25C3330 R,S,T,U,V
TR404	ET-373391	TR DTC143ZS
TR405	*ET-373025	TR 25D1944 J1,J2K
TR406	*ET-397180J	TR 25C3330 R,S,T,U,V
TR407	*ET-397180J	TR 25C3330 R,S,T,U,V
TR408	ET-354364	TR DTC143TS
TR409	ET-400741J	TR 25C3708 T T05
TR410	ET-400741J	TR 25C3708 T T05
TR501	ET-397180J	TR 25C3330 R,S,T,U,V
TR502	ET-397180J	TR 25C3330 R,S,T,U,V
TR503	ET-397180J	TR 25C3330 R,S,T,U,V
TR504	ET-397180J	TR 25C3330 R,S,T,U,V
TR505	ET-397180J	TR 25C3330 R,S,T,U,V
TR506	ET-397180J	TR 25C3330 R,S,T,U,V
TR601	ET-373485	TR DTC123JS
TR602	ET-369248	TR DTA114YS
TR603	ET-373382	TR DTA143ZS
TR606	ET-354365	TR DTC114YS
TR607	ET-354365	TR DTC114YS
TR608	ET-361736	TR 25C3576
TR609	ET-361736	TR 25C3576
TR610	ET-373485	TR DTC123JS
TR611	ET-373391	TR DTC143ZS
TR612	ET-361736	TR 25C3576
TR613	ET-361736	TR 25C3576
TR614	ET-373485	TR DTC123JS
TR615	ET-373391	TR DTC143ZS
TR616	ET-373391	TR DTC143ZS
TR617	ET-408772J	TR 25A1318 S,T,U T05
TR618	ET-408772J	TR 25A1318 S,T,U T05
TR653	ET-353899	TR 25A1317 S,T,U
TR654	ET-353899	TR 25A1317 S,T,U
TR655	ET-373392	TR DTA143ZS
TR656	ET-398072J	TR 25D2159 V,W
TR657	ET-398072J	TR 25D2159 V,W
TR658	ET-398072J	TR 25D2159 V,W
TR659	ET-397160J	TR 25C3330 R,S,T,U,V
TR660	ET-397160J	TR 25C3330 R,S,T,U,V
TR701	*ET-373025	TR 25D1944 J1,J2K
TR702	*ET-397160J	TR 25C3330 R,S,T,U,V
TR703	*ET-408772J	TR 25C3330 R,S,T,U T05
TR704	*ET-353899	TR 25A1317 S,T,U
TR721	*ET-373025	TR 25D1944 J1,J2K
TR722	*ET-397160J	TR 25C3330 R,S,T,U,V
TR741	*ET-366551	TR 25D1762 E,F
TR742	*ET-366551	TR 25D1762 E,F
TR743	*ET-397160J	TR 25C3330 R,S,T,U,V
TR744	*ET-348302	TR FET 25K381 C,D F05
TR745	ET-354365	TR DTC114YS
TR781	ET-373985	TR DTA144TS
TR783	ET-354414	TR DTC144ES
TR784	ET-397160J	TR 25C3330 R,S,T,U,V
TR785	ET-354414	TR DTC144ES
T401	EO-408699J	COIL OSC 1 T2134 100.0KHZ
VR101	EV-404299J	R-S-FIX H T05 KVSF637T 0.1W332
VR102	EV-404299J	R-S-FIX H T05 KVSF637T 0.1W332
VR151	EV-404299J	R-S-FIX H T05 KVSF637T 0.1W332
VR152	EV-404299J	R-S-FIX H T05 KVSF637T 0.1W332
VR301	EV-404299J	R-S-FIX H T05 KVSF637T 0.1W332
VR351	EV-404299J	R-S-FIX H T05 KVSF637T 0.1W332
VR402	EV-330531	R-S-FIX H TM8KV2-1S 0.50W503
VR403	EV-330531	R-S-FIX H TM8KV2-1S 0.50W503
VR651	EV-394561J	R-S-FIX H V8K4-11 (1S) 0.10W102
VR652	EV-394561J	R-S-FIX H V8K4-11 (1S) 0.10W102
VR653	EV-367524	R-S-FIX H V8K4-11 (1S) 0.10W501
VR654	EV-367524	R-S-FIX H V8K4-11 (1S) 0.10W501
X601	EH-373957J1	OSC CE CST4.19MGW 4.194MHZ

### 4. DECK P.C BOARD (HX-750)

Ref.No.	Part No.	Description
C701	EC-363491	C EC V CUT SME 222M 25.0DC
C702	EC-366613	C EC V CUT SME 102M 25.0DC
C741	EC-363491	C EC V CUT SME 222M 25.0DC
D101	ED-307572	D SILICON H 1SS131
D151	ED-307572	D SILICON H 1SS131
D301	ED-307572	D SILICON H 1SS131
D351	ED-307572	D SILICON H 1SS131
D401	ED-391003J	D ZENER H HZS4C3
D501	ED-307572	D SILICON H 1SS131
D502	ED-307572	D SILICON H 1SS131
D503	ED-307572	D SILICON H 1SS131
D504	ED-307572	D SILICON H 1SS131
D505	ED-307572	D SILICON H 1SS131
D601	ED-307572	D SILICON H 1SS131
D602	*ED-408743J	D ZENER H HZS11B3L
D603	ED-307572	D SILICON H 1SS131
D604	ED-307572	D SILICON H 1SS131
D651	ED-307572	D SILICON H 1SS131
D652	ED-307572	D SILICON H 1SS131
D701	*ED-511907	D SILICON 1N4002 100/1.0A
D702	*ED-511907	D SILICON 1N4002 100/1.0A
D703	*ED-511907	D SILICON 1N4002 100/1.0A
D704	*ED-511907	D SILICON 1N4002 100/1.0A
D705	*ED-388320J	D ZENER H HZS12B3L
D706	*ED-388320J	D ZENER H HZS12B3L
D721	*ED-400171J	D ZENER H HZS6C2L
D722	*ED-400171J	D ZENER H HZS6C2L
D723	ED-511907	D SILICON 1N4002 100/1.0A
D724	ED-511907	D SILICON 1N4002 100/1.0A
D725	ED-511907	D SILICON 1N4002 100/1.0A
D726	ED-511907	D SILICON 1N4002 100/1.0A
D741	*ED-511907	D SILICON 1N4002 100/1.0A
D742	*ED-511907	D SILICON 1N4002 100/1.0A
D743	*ED-388320J	D ZENER H HZS12B3L
D761	ED-307572	D SILICON H 1SS131
FL101	EO-356809	COIL TUN 1 100Z-121 100.00KHZ
FL151	EO-356809	COIL TUN 1 100Z-121 100.00KHZ
FL301	EO-356809	COIL TUN 1 100Z-121 100.00KHZ
FL351	EO-356809	COIL TUN 1 100Z-121 100.00KHZ
IB601	EH-408820J	COMP R RGL10T 472J
IB602	EH-408713J	COMP R RGL10T 472J
IB603	EH-408821J	COMP R RGL12T 473J
IC101	EH-310036	IC TC4066BP
IC102	EH-393323J	IC MS218AL-771
IC202	EH-394573J	IC CXA1331S
IC301	EH-393323J	IC MS218AL-771
IC551	EH-394574J	IC LA2000
IC601	EH-408700J1	IC UPD75108CW-W19 MXA1DK2
IC602	EH-387938J	IC HD74LS05P
J201	EJ-394445J	SOCKET 52303-1411 BLACK 14P
L301	EO-394589J	COIL FIX 1 RCP095 822J
L302	EO-393645J	COIL FIX 1 RCP095 392J
L351	EO-394589J	COIL FIX 1 RCP095 822J
L352	EO-393645J	COIL FIX 1 RCP095 392J
L401	EO-403270J	COIL FIX 1 EL0405RA T05 101J
TR101	ET-408709J	TR FET 25K373 Y,GR T05
TR102	ET-375986	TR DTC124TS
TR103	ET-354364	TR DTC143TS
TR104	ET-354364	TR DTC143TS
TR105	ET-354364	TR DTC143TS
TR106	ET-354364	TR DTC143TS
TR107	ET-370310	TR DTC144TS
TR108	ET-370310	TR DTC144TS
TR151	ET-408709J	TR FET 25K373 Y,GR T05
TR152	ET-375986	TR DTC124TS
TR153	ET-354364	TR DTC143TS
TR154	ET-354364	TR DTC143TS
TR155	ET-354364	TR DTC143TS
TR156	ET-354364	TR DTC143TS
TR157	ET-370310	TR DTC144TS
TR158	ET-370310	TR DTC144TS
TR181	ET-369248	TR DTA114YS
TR182	ET-370310	TR DTC144TS
TR183	ET-370310	TR DTC144TS
TR184	ET-369248	TR DTA114YS
TR201	ET-397160J	TR 25C3330 R,S,T,U,V
TR202	ET-397160J	TR 25C3330 R,S,T,U,V
TR251	ET-397160J	TR 25C3330 R,S,T,U,V
TR252	ET-397160J	TR 25C3330 R,S,T,U,V
TR281	ET-354414	TR DTC144ES
TR301	ET-397160J	TR 25C3330 R,S,T,U,V

PARTS LIST

## 5. DECK (A) P.C BOARD (HX-950)

Ref.No.	Part No.	Description
C701	EC-363491	C EC V CUT SME 222M 25.0DC
C703	EC-363491	C EC V CUT SME 222M 25.0DC
D101	ED-307572	D SILICON H 1SS131
D102	ED-307572	D SILICON H 1SS131
D151	ED-307572	D SILICON H 1SS131
D152	ED-307572	D SILICON H 1SS131
D181	ED-307572	D SILICON H 1SS131
D321	ED-307572	D SILICON H 1SS131
D371	ED-307572	D SILICON H 1SS131
D421	ED-307572	D SILICON H 1SS131
D471	ED-307572	D SILICON H 1SS131
D501	ED-391003J	D ZENER H HZS4C3
D551	ED-391003J	D ZENER H HZS4C3
D601	ED-307572	D SILICON H 1SS131
D602	ED-307572	D SILICON H 1SS131
D603	ED-307572	D SILICON H 1SS131
D604	ED-307572	D SILICON H 1SS131
D651	ED-307572	D SILICON H 1SS131
D701	*ED-511907	D SILICON 1N4002 100/1.0A
D702	*ED-511907	D SILICON 1N4002 100/1.0A
D703	*ED-511907	D SILICON 1N4002 100/1.0A
D704	*ED-511907	D SILICON 1N4002 100/1.0A
D705	*ED-511907	D SILICON 1N4002 100/1.0A
D706	*ED-511907	D SILICON 1N4002 100/1.0A
D707	ED-404319J	D ZENER H HZS12B2L
D708	ED-404319J	D ZENER H HZS12B2L
D709	ED-400171J	D ZENER H HZS6C2L
D710	ED-408733J	D ZENER H HZS6A3L
D711	ED-388320J	D ZENER H HZS12B3L
D712	ED-307572	D SILICON H 1SS131
D713	ED-307572	D SILICON H 1SS131
D714	ED-307572	D SILICON H 1SS131
D751	ED-511907	D SILICON 1N4002 100/1.0A
D752	ED-511907	D SILICON 1N4002 100/1.0A
D753	ED-511907	D SILICON 1N4002 100/1.0A
D754	ED-511907	D SILICON 1N4002 100/1.0A
D755	ED-511907	D SILICON 1N4002 100/1.0A
D756	ED-511907	D SILICON 1N4002 100/1.0A
D757	ED-307572	D SILICON H 1SS131
D758	ED-307572	D SILICON H 1SS131
FL101	EO-356809	COIL TUN 1 100Z-121 100.00KHZ
FL151	EO-356809	COIL TUN 1 100Z-121 100.00KHZ
FL301	EO-356809	COIL TUN 1 100Z-121 100.00KHZ
FL351	EO-356809	COIL TUN 1 100Z-121 100.00KHZ
FL401	EO-356809	COIL TUN 1 100Z-121 100.00KHZ
FL451	EO-356809	COIL TUN 1 100Z-121 100.00KHZ
FR701	*ER-200926	R FUSE H S10 ERD2FC 1/4W 27R0G
IB701	EH-387619J	COMP R RGLE14X 103J
IB702	EH-404318J	COMP R RGLE5X 332J
IB703	EH-389421J	COMP R RGLE7X 103J
IC101	EI-310036	IC TC4066BP
IC102	EI-393323J	IC M5218AL-771
IC701	EI-410610J	IC UPD75108CW-W20 MXB1DK1
IC702	EI-337008	IC LC7800
IC703	EI-394569J	IC M66312P
IC704	EI-387938J	IC HD74LS05P
IC901	EI-373383	IC UPC1297CA
IC951	EI-373383	IC UPC1297CA
J701	EJ-394445J	SOCKET 52303-1411 BLACK 14P
L501	EO-403270J	COIL FIX 1 EL0405RA T05 101J
L551	EO-403270J	COIL FIX 1 EL0405RA T05 101J
R711	ER-408692J	R OMF H S15 FS 2W 390J
R906	ER-333342	R CB H S10 FS RDS 1/4W 2R2J
TR101	ET-408709J	TR FET 2SK373 Y,GR T05
TR102	ET-408709J	TR FET 2SK373 Y,GR T05
TR103	ET-354364	TR DTC143TS
TR104	ET-354364	TR DTC143TS
TR105	ET-354364	TR DTC143TS
TR106	ET-354364	TR DTC143TS
TR107	ET-354364	TR DTC143TS
TR108	ET-370310	TR DTC144TS
TR109	ET-370310	TR DTC144TS
TR151	ET-408709J	TR FET 2SK373 Y,GR T05
TR152	ET-408709J	TR FET 2SK373 Y,GR T05
TR153	ET-354364	TR DTC143TS
TR154	ET-354364	TR DTC143TS
TR155	ET-354364	TR DTC143TS
TR156	ET-354364	TR DTC143TS
TR157	ET-354364	TR DTC143TS
TR158	ET-354364	TR DTC143TS
TR159	ET-354364	TR DTC143TS

Ref.No.	Part No.	Description
TR159	ET-370310	TR DTC144TS
TR181	ET-369248	TR DTA114YS
TR182	ET-369248	TR DTA114YS
TR183	ET-370310	TR DTC144TS
TR184	ET-370310	TR DTC144TS
TR201	ET-397160J	TR 2SC3330 R,S,T,U,V
TR202	ET-397160J	TR 2SC3330 R,S,T,U,V
TR251	ET-397160J	TR 2SC3330 R,S,T,U,V
TR252	ET-397160J	TR 2SC3330 R,S,T,U,V
TR321	ET-408777J	TR FET 2SJ40 D,E T05
TR371	ET-408777J	TR FET 2SJ40 D,E T05
TR391	ET-369248	TR DTA114YS
TR421	ET-408777J	TR FET 2SJ40 D,E T05
TR471	ET-408777J	TR FET 2SJ40 D,E T05
TR491	ET-369248	TR DTA114YS
TR501	ET-354414	TR DTC144ES
TR502	ET-354414	TR DTC144ES
TR503	ET-373391	TR DTC143ZS
TR504	ET-397160J	TR 2SC3330 R,S,T,U,V
TR505	*ET-373025	TR 2SD1944 J1,J2,K
TR506	ET-397160J	TR 2SC3330 R,S,T,U,V
TR507	ET-397160J	TR 2SC3330 R,S,T,U,V
TR508	ET-354364	TR DTC143TS
TR509	ET-354364	TR DTC143TS
TR510	ET-400741J	TR 2SC3708 T T05
TR511	ET-400741J	TR 2SC3708 T T05
TR551	ET-354414	TR DTC144ES
TR552	ET-354414	TR DTC144ES
TR553	ET-373391	TR DTC143ZS
TR554	ET-397160J	TR 2SC3330 R,S,T,U,V
TR555	*ET-373025	TR 2SD1944 J1,J2,K
TR556	ET-397160J	TR 2SC3330 R,S,T,U,V
TR557	ET-397160J	TR 2SC3330 R,S,T,U,V
TR558	ET-354364	TR DTC143TS
TR559	ET-354364	TR DTC143TS
TR560	ET-400741J	TR 2SC3708 T T05
TR561	ET-400741J	TR 2SC3708 T T05
TR601	ET-397160J	TR 2SC3330 R,S,T,U,V
TR602	ET-397160J	TR 2SC3330 R,S,T,U,V
TR603	ET-397160J	TR 2SC3330 R,S,T,U,V
TR604	ET-397160J	TR 2SC3330 R,S,T,U,V
TR651	ET-397160J	TR 2SC3330 R,S,T,U,V
TR652	ET-397160J	TR 2SC3330 R,S,T,U,V
TR701	*ET-373025	TR 2SD1944 J1,J2,K
TR702	ET-404320J	TR 2SC3331 T,U T05
TR703	*ET-373025	TR 2SD1944 J1,J2,K
TR704	ET-404320J	TR 2SC3331 T,U T05
TR705	*ET-408772J	TR 2SA1318 S,T,U T05
TR706	ET-408772J	TR 2SA1318 S,T,U T05
TR707	ET-397160J	TR 2SC3330 R,S,T,U,V
TR708	*ET-366581	TR 2SD1762 E,F
TR709	*ET-366581	TR 2SD1762 E,F
TR710	ET-348302	TR FET 2SK381 C,D F05
TR711	ET-397160J	TR 2SC3330 R,S,T,U,V
TR712	*ET-366581	TR 2SD1762 E,F
TR713	*ET-366581	TR 2SD1762 E,F
TR714	ET-354365	TR DTC114YS
TR715	ET-373382	TR DTA143ZS
TR716	ET-396072J	TR 2SD2159 V,W
TR717	ET-396072J	TR 2SD2159 V,W
TR718	ET-396072J	TR 2SD2159 V,W
TR719	ET-397160J	TR 2SC3330 R,S,T,U,V
TR720	ET-397160J	TR 2SC3330 R,S,T,U,V
TR721	ET-353899	TR 2SA1317 S,T,U
TR722	ET-353899	TR 2SA1317 S,T,U
TR723	ET-373485	TR DTC123JS
TR724	ET-373485	TR DTC123JS
TR725	ET-373485	TR DTC123JS
TR726	ET-369248	TR DTA114YS
TR727	ET-373382	TR DTA143ZS
TR728	ET-373382	TR DTA143ZS
TR729	ET-354414	TR DTC144ES
TR730	ET-354414	TR DTC144ES
TR731	ET-397160J	TR 2SC3330 R,S,T,U,V
TR732	ET-397160J	TR 2SC3330 R,S,T,U,V
T501	EO-408762J	COIL OSC 1 T2135-1 100.0KHZ
T551	EO-408762J	COIL OSC 1 T2135-1 100.0KHZ
T901	EO-408763J	COIL OSC 1 T2135-2 (HX) 100.0KHZ
T902	EO-408763J	COIL OSC 1 T2135-2 (HX) 100.0KHZ
T951	EO-408763J	COIL OSC 1 T2135-2 (HX) 100.0KHZ
T952	EO-408763J	COIL OSC 1 T2135-2 (HX) 100.0KHZ
VR101	EV-404299J	R S-FIX H T05 KVSF637T 0.1W332



Ref.No.	Part No.	Description
VR151	EV-404299J	R S-FIX H T05 KVSF637T 0.1W332
VR152	EV-404299J	R S-FIX H T05 KVSF637T 0.1W332
VR502	EV-404294J	R S-FIX H T05 KVSF637T 0.1W102
VR552	EV-404294J	R S-FIX H T05 KVSF637T 0.1W102
VR701	EV-394561J	R S-FIX H V8K4-11 (1S) 0.10W102
VR702	EV-367524	R S-FIX H V8K4-11 (1S) 0.10W501
VR703	EV-394561J	R S-FIX H V8K4-11 (1S) 0.10W102
VR704	EV-367524	R S-FIX H V8K4-11(1S) 0.10W501
VR901	EV-405657J	R S-FIX H T05 KVSF637T 0.1W103
VR902	EV-405657J	R S-FIX H T05 KVSF637T 0.1W103
VR951	EV-405657J	R S-FIX H T05 KVSF637T 0.1W103
VR952	EV-405657J	R S-FIX H T05 KVSF637T 0.1W103
X701	EI-373957J1	OSC CE CST4.19MGW 4.194MHZ

## 6. DECK (B) P.C BOARD (HX-950)

Ref.No.	Part No.	Description
IC201	EI-394573J	IC CXA1331S
IC301	EI-393323J	IC M5218AL-771
IC401	EI-393323J	IC M5218AL-771
IC681	EI-394574J	IC LA2000
L301	EO-394589J	COIL FIX 1 RCP095 822J
L351	EO-394589J	COIL FIX 1 RCP095 822J
L401	EO-394589J	COIL FIX 1 RCP095 822J
L402	EO-393645J	COIL FIX 1 RCP095 392J
L451	EO-394589J	COIL FIX 1 RCP095 822J
L452	EO-393645J	COIL FIX 1 RCP095 392J
TR281	ET-354365	TR DTC114YS
TR301	ET-397160J	TR 2SC3330 R,S,T,U,V
TR302	ET-354364	TR DTC143TS
TR303	ET-354364	TR DTC143TS
TR304	ET-354364	TR DTC143TS
TR351	ET-397160J	TR 2SC3330 R,S,T,U,V
TR352	ET-354364	TR DTC143TS
TR353	ET-354364	TR DTC143TS
TR354	ET-354364	TR DTC143TS
TR381	ET-360399	TR DTC114TS
TR401	ET-397160J	TR 2SC3330 R,S,T,U,V
TR402	ET-354364	TR DTC143TS
TR403	ET-354364	TR DTC143TS
TR404	ET-354364	TR DTC143TS
TR405	ET-354364	TR DTC143TS
TR406	ET-354364	TR DTC143TS
TR451	ET-397160J	TR 2SC3330 R,S,T,U,V
TR452	ET-354364	TR DTC143TS
TR453	ET-354364	TR DTC143TS
TR454	ET-354364	TR DTC143TS
TR455	ET-354364	TR DTC143TS
TR456	ET-354364	TR DTC143TS
TR481	ET-360399	TR DTC114TS
VR301	EV-403967J	R S-FIX V T05EVNDCAA03 0.1W332
VR351	EV-403967J	R S-FIX V T05EVNDCAA03 0.1W332
VR401	EV-403967J	R S-FIX V T05EVNDCAA03 0.1W332
VR451	EV-403967J	R S-FIX V T05EVNDCAA03 0.1W332

## 7. OPERATION P.C BOARD

Ref.No.	Part No.	Description
D801	ED-394509J	D LED GL3HY43 ORANGE
D802A	ED-394509J	D LED GL3HY43 ORANGE [750]
D802B	ED-394724J	D LED GL3PR43 RED [950]
D803	ED-394509J	D LED GL3HY43 ORANGE
D804	ED-394509J	D LED GL3HY43 ORANGE
D805A	ED-394509J	D LED GL3HY43 ORANGE [750]
D805B	ED-394724J	D LED GL3PR43 RED [950]
D806	ED-394509J	D LED GL3HY43 ORANGE
D807A	ED-408651J	D LED SEL2913K ORANGE [750]
D807B	ED-394509J	D LED GL3HY43 ORANGE [950]
D808A	ED-408651J	D LED SEL2913K ORANGE [750]
D808B	ED-394509J	D LED GL3HY43 ORANGE [950]
D809A	ED-394724J	D LED GL3PR43 RED [750]
D809B	ED-408651J	D LED SEL2913K ORANGE [950]
D810	ED-408651J	D LED SEL2913K ORANGE [950]
SW801	ES-408708J	SW SLIDE SSSS91 L=2 1-01-03
SW802	ES-408708J	SW SLIDE SSSS91 L=2 1-01-03 [950]
TS801	ES-408641J	SW TACT EVQ 233 07K T05
TS802	ES-408641J	SW TACT EVQ 233 07K T05
TS803	ES-408641J	SW TACT EVQ 233 07K T05
TS804	ES-408641J	SW TACT EVQ 233 07K T05
TS805	ES-408641J	SW TACT EVQ 233 07K T05
TS806	ES-408641J	SW TACT EVQ 233 07K T05
TS807	ES-408641J	SW TACT EVQ 233 07K T05
TS808	ES-408641J	SW TACT EVQ 233 07K T05
TS809	ES-408641J	SW TACT EVQ 233 07K T05
TS810	ES-408641J	SW TACT EVQ 233 07K T05
TS811	ES-408641J	SW TACT EVQ 233 07K T05

## FINAL ASSEMBLY

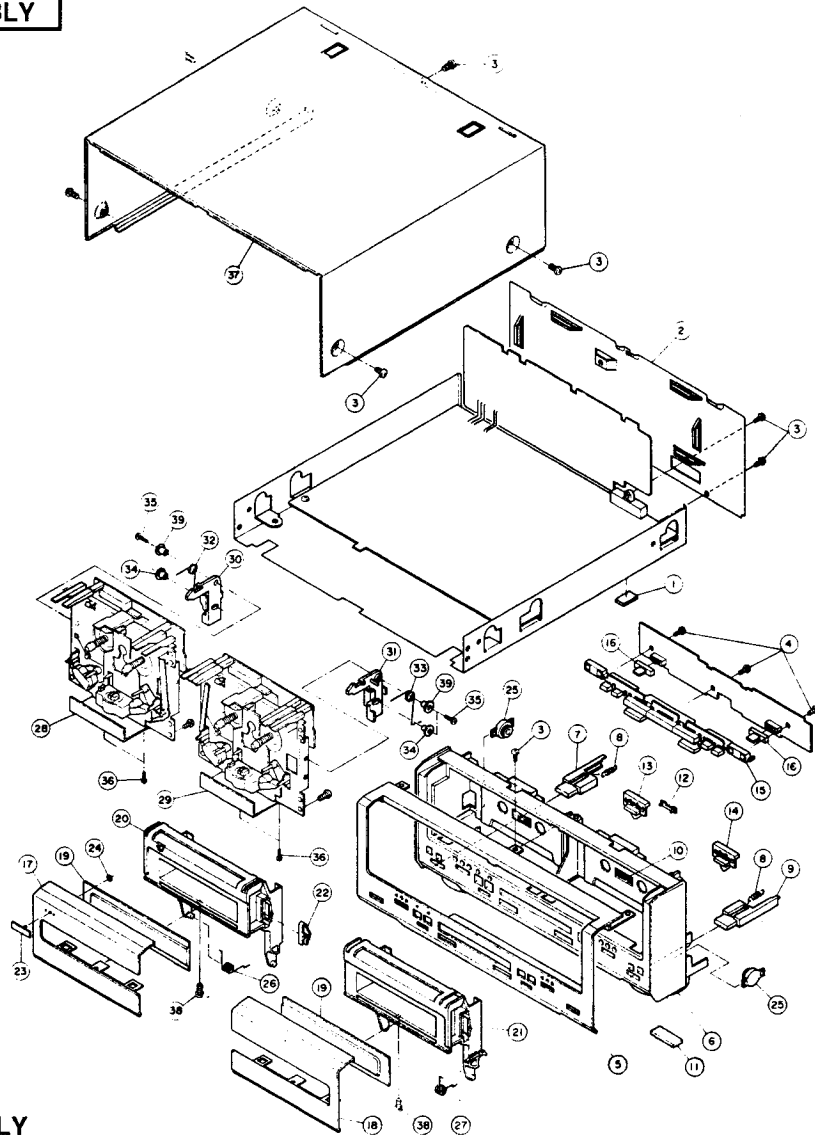

### 8. FINAL ASSEMBLY

Ref.No.	Part No.	Description	Ref.No.	Part No.	Description
1	SA-407840M	CUSHION FOOT REAR (SG)	22	ZG-394158M	SP PLATE CASSETTE HOLDER (SG)
2A	SP-408144M	PANEL REAR HX-750 (U) (SG)	23	SM-409218J	NAME PLATE AKAI-S
2B	SP-408145M	PANEL REAR HX-750 (E) (SG)	24	ZW-408744J	PUSH NUT SPN-2
2C	SP-408146M	PANEL REAR HX-950 (U) (SG)	25	MZ-408740J	DUMPER 2G50-C
2D	SP-408147M	PANEL REAR HX-950 (E) (SG)	26	ZG-408124M1	SP TORSION EJECT (L) (SG)
3	ZS-394412M	BT BID30X08STL BZN PROJECTION	27	ZG-408125M1	SP TORSION EJECT (R) (SG)
4	ZS-331182	BT BID30X08STL BNI	28A	BB-408782M1	MECHA GAK9302 [750 TAPE-1]
5A	SP-408130J	PANEL FRONT 750	28B	BB-408783M1	MECHA GAK9603 [950 TAPE-1]
5B	SP-408149J	PANEL FRONT 950	29A	BB-410525M1	MECHA GAK9604 [750 TAPE-2]
6	SE-408129M	ESCUTCHEON FRONT (SG)	29B	BB-408781M1	MECHA GAK9602 [950 TAPE-2]
7	SB-408140M	BUTTON EJECT (L) (SG)	30	ML-408121M	LEVER EJECT (L) (SG)
8	ZG-408164M	SP PULL EJECT BUTTON (SG)	31	ML-408128M	LEVER EJECT (R) (SG)
9	SB-408141M	BUTTON EJECT (R) (SG)	32	ZG-408122M1	SP TORSION LEVER EJECT (L) (SG)
10	SE-394092M	REFLECTOR (SG)	33	ZG-408123M1	SP TORSION LEVER EJECT (R) (SG)
11	SA-394136M	CUSHION FOOT (SG)	34	MZ-408127M	COLLAR (SG)
12	SE-408138M	LENS INDICATOR (SG)	35	ZS-715857	T2BID20X10STL CMT
13A	SB-409356M	BUTTON TAPE (3) (SG)	36	ZS-357727	ST PAN20X05STL CMT
13B	SB-408142M	BUTTON TAPE (1) (SG)	37	SP-408143M	COVER UPPER (SG)
14	SB-408153M	BUTTON TAPE (2) (SG)	38	ZS-404181M	BT BID30X06STL BZN (SG)
15	SB-408139M	BUTTON OP (SG)	39	MZ-411095J	COLLAR EJECT
16	SK-407866M	KNOB SLIDE (SG)			
17A	SP-408133J	LID PANEL (L) 750			
17B	SP-408154J	LID PANEL (L) 950			
18A	SP-408134J	LID PANEL (R) 750			
18B	SP-408155J	LID PANEL (R) 950			
19	SE-408136M	WINDOW LID (SG)			
20	MZ-408131M	HOLDER LID (L) (SG)			
21	MZ-408132M	HOLDER LID (R) (SG)			

#### NOTE:

Parts will not be supplied if they are not listed in the parts list, even if they appear on the assembling illustrations

# INDEX

Part No.	Ref. No.	Part No.	Ref. No.	Part No.	Ref. No.	Part No.	Ref. No.
BAT2134T070A	3-1A	ED400171J	4-D721	EO356809	5-FL351	ET354364	5-TR153
BAT2135T070A	3-1B	ED400171J	4-D722	EO356809	5-FL401	ET354364	5-TR154
BB408781M1	8-29B	ED400171J	5-D709	EO356809	5-FL451	ET354364	5-TR155
BB408782M1	8-28A	ED404319J	5-D707	EO393645J	4-L302	ET354364	5-TR156
BB408783M1	8-28B	ED404319J	5-D708	EO393645J	4-L352	ET354364	5-TR157
BB410525M1	8-29A	ED408651J	7-D807A	EO393645J	6-L402	ET354364	5-TR158
BF733191J	2-103	ED408651J	7-D808A	EO393645J	6-L452	ET354364	5-TR159
BF733192J	2-104	ED408651J	7-D809B	EO394589J	4-L301	ET354364	5-TR157
BM729992J	2-89A	ED408651J	7-D810	EO394589J	4-L351	ET354364	5-TR558
BM729993J	2-89B	ED408733J	5-D710	EO394589J	6-L301	ET354364	5-TR559
							6-TR302
BZ733179J	2-102	ED408743J	4-D602	EO394589J	6-L351	ET354364	6-TR303
BZ733194J	2-106	ED511907	4-D701	EO394589J	6-L401	ET354364	6-TR304
EC322028	2-110	ED511907	4-D702	EO394589J	6-L451	ET354364	6-TR352
EC363491	4-C701	ED511907	4-D703	EO403270J	4-L401	ET354364	6-TR353
EC363491	4-C741	ED511907	4-D704	EO403270J	5-L501	ET354364	6-TR354
EC363491	5-C701	ED511907	4-D723	EO403270J	5-L551	ET354364	6-TR402
EC363491	5-C703	ED511907	4-D724	EO408699J	4-T401	ET354364	6-TR403
EC366613	4-C702	ED511907	4-D725	EO408762J	5-T501	ET354364	6-TR404
ED307572	4-D101	ED511907	4-D726	EO408762J	5-T551	ET354364	6-TR405
ED307572	4-D151	ED511907	4-D741	EO408763J	5-T901	ET354364	6-TR406
ED307572	4-D301	ED511907	4-D742	EO408763J	5-T902	ET354364	6-TR452
ED307572	4-D351	ED511907	5-D701	EO408763J	5-T951	ET354364	6-TR453
ED307572	4-D501	ED511907	5-D702	EO408763J	5-T952	ET354364	6-TR454
ED307572	4-D502	ED511907	5-D703	EP733165J	2-82	ET354364	6-TR455
ED307572	4-D503	ED511907	5-D704	ER200926	5-FR701	ET354364	6-TR456
ED307572	4-D504	ED511907	5-D705	ER333342	5-R906	ET354365	4-TR606
ED307572	4-D505	ED511907	5-D706	ER341091	2-73	ET354365	4-TR607
ED307572	4-D601	ED511907	5-D751	ER408692J	5-R711	ET354365	4-TR745
ED307572	4-D603	ED511907	5-D752	ES408641J	7-TS801	ET354365	5-TR714
ED307572	4-D604	ED511907	5-D753	ES408641J	7-TS802	ET354365	6-TR281
ED307572	4-D651	ED511907	5-D754	ES408641J	7-TS803	ET354414	4-TR281
ED307572	4-D652	ED511907	5-D755	ES408641J	7-TS804	ET354414	4-TR401
ED307572	4-D761	ED511907	5-D756	ES408641J	7-TS805	ET354414	4-TR402
ED307572	5-D101	EH387619J	5-IB701	ES408641J	7-TS806	ET354414	4-TR763
ED307572	5-D102	EH389421J	5-IB703	ES408641J	7-TS807	ET354414	4-TR765
ED307572	5-D151	EH404318J	5-IB702	ES408641J	7-TS808	ET354414	5-TR501
ED307572	5-D152	EH408713J	4-IB602	ES408641J	7-TS809	ET354414	5-TR502
ED307572	5-D181	EH408820J	4-IB601	ES408641J	7-TS810	ET354414	5-TR551
ED307572	5-D321	EH408821J	4-IB603	ES408641J	7-TS811	ET354414	5-TR552
ED307572	5-D371	EI310036	4-IC101	ES408708J	7-SW801	ET354414	5-TR729
ED307572	5-D421	EI310036	5-IC101	ES408708J	7-SW802	ET354414	5-TR730
ED307572	5-D471	EI337008	5-IC702	ES733163J	2-80	ET360399	6-TR381
ED307572	5-D601	EI373383	5-IC901	ES733164J	2-81	ET360399	6-TR481
ED307572	5-D602	EI373383	5-IC951	ET348302	4-TR744	ET361736	4-TR608
ED307572	5-D603	EI373957J1	4-X601	ET348302	5-TR710	ET361736	4-TR609
ED307572	5-D604	EI373957J1	5-X701	ET353899	4-TR653	ET361736	4-TR612
ED307572	5-D651	EI387938J	4-IC602	ET353899	4-TR654	ET361736	4-TR613
ED307572	5-D712	EI387938J	5-IC704	ET353899	4-TR704	ET366581	4-TR741
ED307572	5-D713	EI393323J	4-IC102	ET353899	5-TR721	ET366581	4-TR742
ED307572	5-D714	EI393323J	4-IC301	ET353899	5-TR722	ET366581	5-TR708
ED307572	5-D757	EI393323J	5-IC102	ET354364	4-TR103	ET366581	5-TR709
ED307572	5-D758	EI393323J	6-IC301	ET354364	4-TR104	ET366581	5-TR712
ED388320J	4-D705	EI393323J	6-IC401	ET354364	4-TR105	ET366581	5-TR713
ED388320J	4-D706	EI394569J	5-IC703	ET354364	4-TR106	ET369248	4-TR181
ED388320J	4-D743	EI394573J	4-IC202	ET354364	4-TR153	ET369248	4-TR184
ED388320J	5-D711	EI394573J	6-IC201	ET354364	4-TR154	ET369248	4-TR381
ED391003J	4-D401	EI394574J	4-IC551	ET354364	4-TR155	ET369248	4-TR602
ED391003J	5-D501	EI394574J	6-IC681	ET354364	4-TR156	ET369248	5-TR181
ED391003J	5-D551	EI408700J1	4-IC601	ET354364	4-TR302	ET369248	5-TR182
ED394509J	7-D801	EI410610J	5-IC701	ET354364	4-TR303	ET369248	5-TR391
ED394509J	7-D802A	EJ394445J	4-J201	ET354364	4-TR304	ET369248	5-TR491
ED394509J	7-D803	EJ394445J	5-J701	ET354364	4-TR352	ET369248	5-TR726
ED394509J	7-D804	EJ733170J	2-86	ET354364	4-TR353	ET370310	4-TR107
ED394509J	7-D805A	EO356809	4-FL101	ET354364	4-TR354	ET370310	4-TR108
ED394509J	7-D806	EO356809	4-FL151	ET354364	4-TR408	ET370310	4-TR157
ED394509J	7-D807B	EO356809	4-FL301	ET354364	5-TR103	ET370310	4-TR158
ED394509J	7-D808B	EO356809	4-FL351	ET354364	5-TR104	ET370310	4-TR182
ED394724J	7-D802B	EO356809	5-FL101	ET354364	5-TR105	ET370310	4-TR183
ED394724J	7-D805B	EO356809	5-FL151	ET354364	5-TR106	ET370310	5-TR108
ED394724J	7-D809A	EO356809	5-FL301	ET354364	5-TR107	ET370310	5-TR109

Part No.	Ref. No.	Part No.	Ref. No.	Part No.	Ref. No.	Part No.	Ref. No.
ET370310	5-TR158	ET397160J	5-TR603	EW733167J	2-84	ZG408124M1	8-26
ET370310	5-TR159	ET397160J	5-TR604	EW733168J	2-85A	ZG408125M1	8-27
ET370310	5-TR183	ET397160J	5-TR651	EW733169J	2-85B	ZG408164M	8-8
ET370310	5-TR184	ET397160J	5-TR652	HP733172J	2-90A	ZG733087J	2-2
ET373025	4-TR405	ET397160J	5-TR707	HR733173J	2-90B	ZG733091J	2-6
ET373025	4-TR701	ET397160J	5-TR711	HZ733090J	2-5	ZG733133J	2-50
ET373025	4-TR721	ET397160J	5-TR719	HZ733119J	2-36	ZG733134J	2-51
ET373025	5-TR505	ET397160J	5-TR720	MA733176J	2-99	ZG733136J	2-53
ET373025	5-TR555	ET397160J	5-TR731	MB733130J	2-47	ZG733138J	2-55
ET373025	5-TR701	ET397160J	5-TR732	ML408121M	8-30	ZG733139J	2-56
ET373025	5-TR703	ET397160J	6-TR301	ML408128M	8-31	ZG733140J	2-57
ET373382	4-TR603	ET397160J	6-TR351	ML733088J	2-3	ZG733141J	2-58
ET373382	4-TR655	ET397160J	6-TR401	ML733106J	2-23	ZG733142J	2-59
ET373382	5-TR715	ET397160J	6-TR451	ML733111J	2-28	ZG733143J	2-60
ET373382	5-TR727	ET400741J	4-TR409	ML733115J	2-32	ZG733144J	2-61
ET373382	5-TR728	ET400741J	4-TR410	ML733117J	2-34	ZG733145J	2-62
ET373391	4-TR404	ET400741J	5-TR510	ML733118J	2-35	ZG733146J	2-63A
ET373391	4-TR611	ET400741J	5-TR511	ML733123J	2-40	ZG733147J	2-63B
ET373391	4-TR615	ET400741J	5-TR560	ML733124J	2-41	ZG733152J	2-68
ET373391	4-TR616	ET400741J	5-TR561	ML733125J	2-42	ZG733154J	2-70
ET373391	5-TR503	ET404320J	5-TR702	MR733128J	2-45	ZS321320	2-93
ET373391	5-TR553	ET404320J	5-TR704	MR733129J	2-46	ZS331182	8-4
ET373485	4-TR601	ET408709J	4-TR101	MS733097J	2-13	ZS357727	8-36
ET373485	4-TR610	ET408709J	4-TR151	MS733122J	2-39	ZS394412M	8-3
ET373485	4-TR614	ET408709J	5-TR101	MT733109J	2-26	ZS404181M	8-38
ET373485	5-TR723	ET408709J	5-TR102	MT733110J	2-27	ZS432843	2-95
ET373485	5-TR724	ET408709J	5-TR151	MZ408127M	8-34	ZS460440	2-91
ET373485	5-TR725	ET408709J	5-TR152	MZ408131M	8-20	ZS715857	8-35
ET373985	4-TR761	ET408772J	4-TR617	MZ408132M	8-21	ZS733174J	2-94
ET375986	4-TR102	ET408772J	4-TR618	MZ408740J	8-25	ZS733175J	2-96
ET375986	4-TR152	ET408772J	4-TR703	MZ411095J	8-39	ZW408744J	8-24
ET396072J	4-TR656	ET408772J	5-TR705	MZ733096J	2-12	ZW733149J	2-65
ET396072J	4-TR657	ET408772J	5-TR706	MZ733104J	2-21	ZW733157J	2-74
ET396072J	4-TR658	ET408777J	4-TR305	MZ733105J	2-22	ZW733158J	2-75
ET396072J	5-TR716	ET408777J	4-TR355	MZ733107J	2-24	ZW733159J	2-76
ET396072J	5-TR717	ET408777J	5-TR321	MZ733108J	2-25	ZW733160J	2-77
ET396072J	5-TR718	ET408777J	5-TR371	MZ733116J	2-33	ZW733161J	2-78
ET397160J	4-TR201	ET408777J	5-TR421	MZ733120J	2-37		
ET397160J	4-TR202	ET408777J	5-TR471	MZ733121J	2-38		
ET397160J	4-TR251	ET733156J	2-72	MZ733131J	2-48		
ET397160J	4-TR252	EV330531	4-VR402	MZ733132J	2-49		
ET397160J	4-TR301	EV330531	4-VR403	SA394136M	8-11		
ET397160J	4-TR351	EV367524	4-VR653	SA407840M	8-1		
ET397160J	4-TR403	EV367524	4-VR654	SB408139M	8-15		
ET397160J	4-TR406	EV367524	5-VR702	SB408140M	8-7		
ET397160J	4-TR407	EV367524	5-VR704	SB408141M	8-9		
ET397160J	4-TR501	EV394561J	4-VR651	SB408142M	8-13B		
ET397160J	4-TR502	EV394561J	4-VR652	SB408153M	8-14		
ET397160J	4-TR503	EV394561J	5-VR701	SB409356M	8-13A		
ET397160J	4-TR504	EV394561J	5-VR703	SE394092M	8-10		
ET397160J	4-TR505	EV403967J	6-VR301	SE408129M	8-6		
ET397160J	4-TR506	EV403967J	6-VR351	SE408136M	8-19		
ET397160J	4-TR659	EV403967J	6-VR401	SE408138M	8-12		
ET397160J	4-TR660	EV403967J	6-VR451	SK407866M	8-16		
ET397160J	4-TR702	EV404294J	5-VR502	SM409218J	8-23		
ET397160J	4-TR722	EV404294J	5-VR552	SP408130J	8-5A		
ET397160J	4-TR743	EV404299J	4-VR101	SP408133J	8-17A		
ET397160J	4-TR764	EV404299J	4-VR102	SP408134J	8-18A		
ET397160J	5-TR201	EV404299J	4-VR151	SP408143M	8-37		
ET397160J	5-TR202	EV404299J	4-VR152	SP408144M	8-2A		
ET397160J	5-TR251	EV404299J	4-VR301	SP408145M	8-2B		
ET397160J	5-TR252	EV404299J	4-VR351	SP408146M	8-2C		
ET397160J	5-TR504	EV404299J	5-VR101	SP408147M	8-2D		
ET397160J	5-TR506	EV404299J	5-VR102	SP408149J	8-5B		
ET397160J	5-TR507	EV404299J	5-VR151	SP408154J	8-17B		
ET397160J	5-TR554	EV404299J	5-VR152	SP408155J	8-18B		
ET397160J	5-TR556	EV405657J	5-VR901	SZ733150J	2-66		
ET397160J	5-TR557	EV405657J	5-VR902	ZG394158M	8-22		
ET397160J	5-TR601	EV405657J	5-VR951	ZG408122M1	8-32		
ET397160J	5-TR602	EV405657J	5-VR952	ZG408123M1	8-33		

## ABBREVIATIONS (CASSETTE)

ABBREVIATION	EXPLANATION	ABBREVIATION	EXPLANATION
AC	Alternating Current	MIN	MINute
A/D	Analog/Digital	MML	Maximum Modulation Level
AF	Auto Fader	MOL	Maximum Output Level
AMP	AMPlifier	MPX	Multi PleX
AR	Anti Recording	NC	Not Connected (No Connection)
AT BIAS	Auto Turning BIAS	NFB	Negative Feed Back
ATT	ATTenuator	NORM	NORMAl
BAL	BALance	NR	Noise Reduction
BEF	Band Elimination Filter	OSC	OSCillator (OSCillation)
BSS	Blank Search System	P	Pulse
CAP M	CAPstan Motor	PB	Play Back
CH	CHannel	QMSS	Quick Memory Search System
COMP	COMParator	QR	Quick Reverse
CONT	CONTinuance	R CH	Right CHannel
CRLP	Computer Recording Level Processing	REC	RECord (RECording)
CS	Chip Select	REV	REVerse
D/A	Digital/Analog	ROT	ROTation
DC	Direct Current	REW	REWind
DET	DETector	SEC	SECond
DISCRI	DISCRIminator	SELE	SELEctor
DUB	DUBbing	SENS	SENSitivity
EQ	EQualizer	SEPP	Single Ended Push Pull
FF (or F.FWD)	Fast Foward	SIG	SIGnal
FLD	FLuoresent Display	SPECT	SPECTrum
FREQ	FREQuency	STD	STanDard
FWD	ForWarD	SW	SWitch
GND	GrouND	SYSCON	SYStem CONtrol
H	High	TP	Test Point
HPF	High Pass Filter	TRIG	TRIGa
IND	INDicator	VCA	Voltage Control Attenuator
IPLS	Instant Program Location System	VOL	VOLume
L	Low	VOLT	VOLTage
L CH	Left CHannel	VR	Variable Resistor
LED	Light Emitining Diode	X'TAL	cysTAL
MEMO	MEMOry	X1	Normal speed
MICOM	MicroCOMputer	X2	Dubble speed

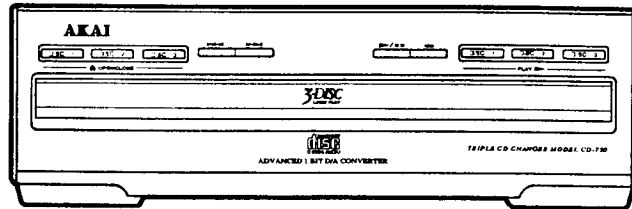

## MULTI COMPACT DISC PLAYER

# MODEL CD-750

## SPECIFICATIONS

Type .....	3 discs auto changer
Pick up system .....	3 beam laser pick-up
Sampling frequency .....	44.1kHz
Error correction system .....	Cross interleave reed solomon
Number of channels .....	2 channel stereo
Frequency response .....	20 to 20,000Hz $\pm$ 1dB
S/N ratio .....	97dB (A-weight)
Wow & flutter .....	Less than measurable limits
Total harmonic distortion .....	0.01% (at 1kHz)
Channel separation .....	85dB (at 1kHz)
Dynamic range .....	95dB
Dimensions .....	270 (W) x 88 (H) x 324 (D)mm
Weight .....	2.7kg
Power requirement .....	Supplied from the PA-750/950 through the TP-750.
Power consumption .....	10W

\* For improvement purposes, specifications and design are subject to change without notice.

# I. DISASSEMBLY

In case of trouble, etc., necessitating dismantling, please dismantle in the order shown in the illustrations. Reassemble in the reverse order.

1. Removal of the UPPER COVER

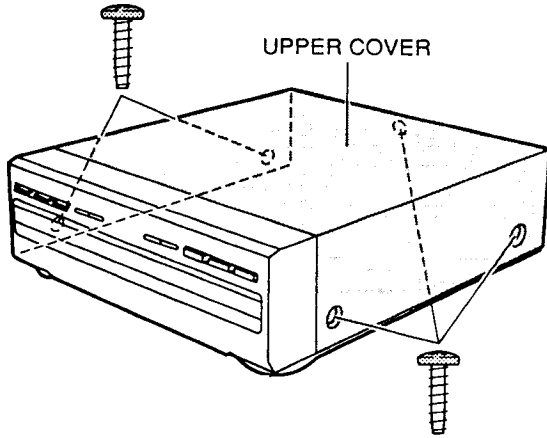

3.

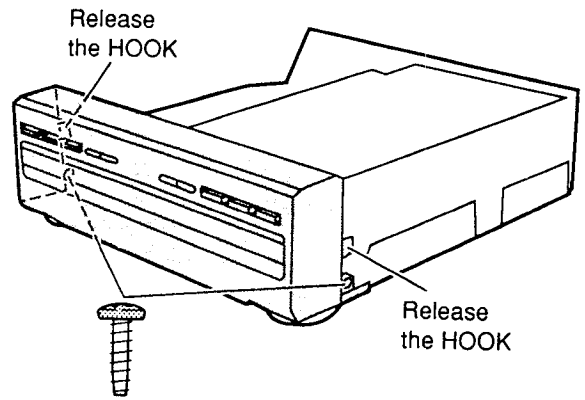

2. Removal of the FRONT PANEL

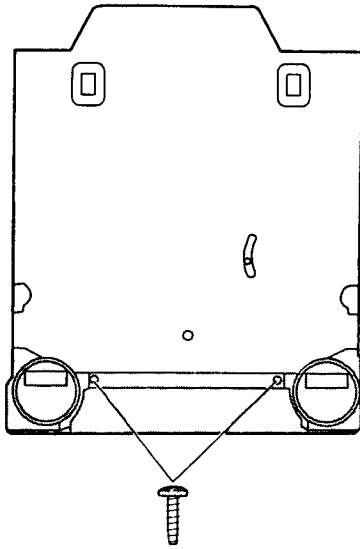

4. Removal of the BOTTOM COVER

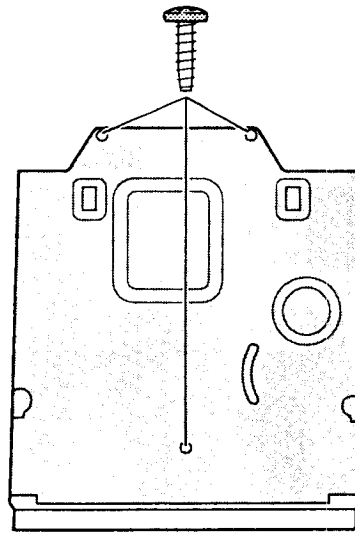

## II. PRINCIPAL PARTS LOCATION

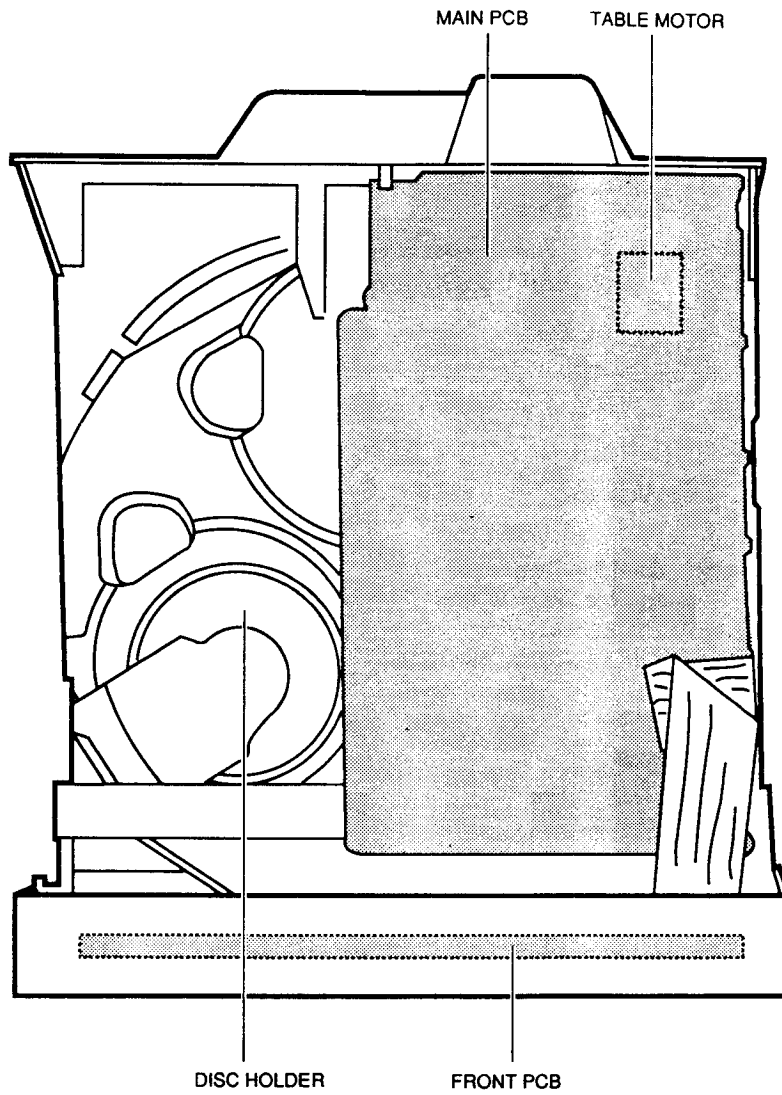

Fig.2-1 Top view

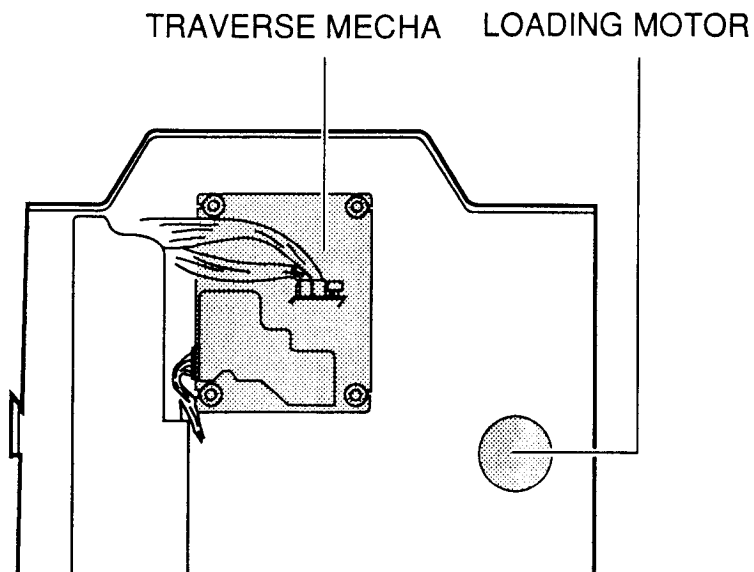

Fig 2-2 Bottom view



# III. REPLACEMENT OF THE PRINCIPAL COMPONENTS

## 3-1. DISMANTLING PROCEDURE OF THE COMPONENTS

When replacement of the mechanical parts is necessary, replace them using the following procedure.

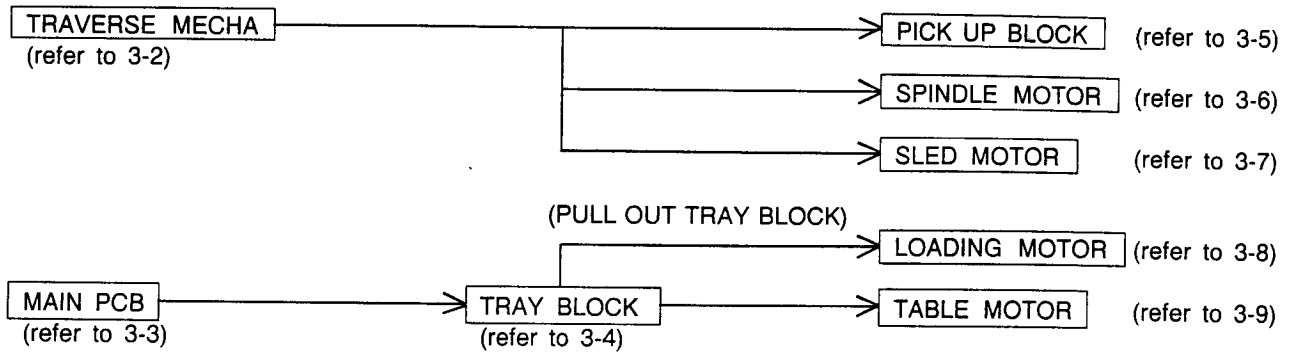

## 3-2. REMOVAL OF THE TRAVERSE MECHA.

- 1) Disconnect the three connectors carefully (two connectors are on the PICK UP PCB and the other is on the MOTOR PCB of the TRAVERSE MECHA.).
- 2) Remove the four retaining screws, then remove the PICK UP UNIT.

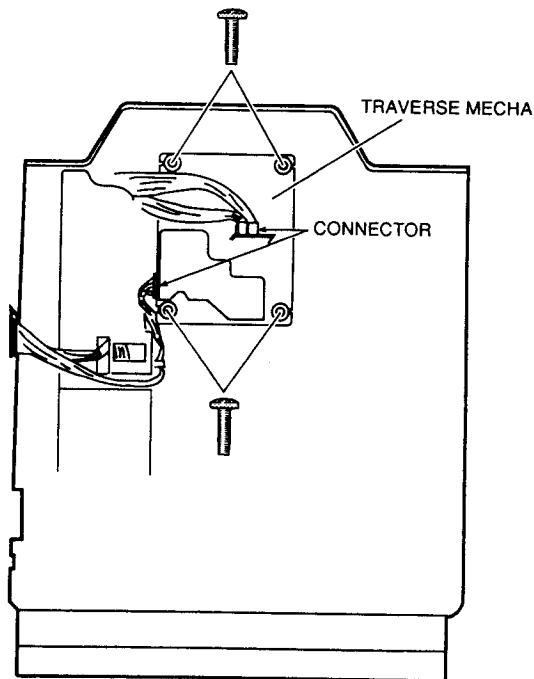

Fig.3-1

## 3-3. REMOVAL OF THE MAIN PCB

- 1) Disconnect the P4, P5 and P6 connectors on the MAIN PCB.
- 2) Remove the four retaining screws of the MAIN PCB, then remove the MAIN PCB.

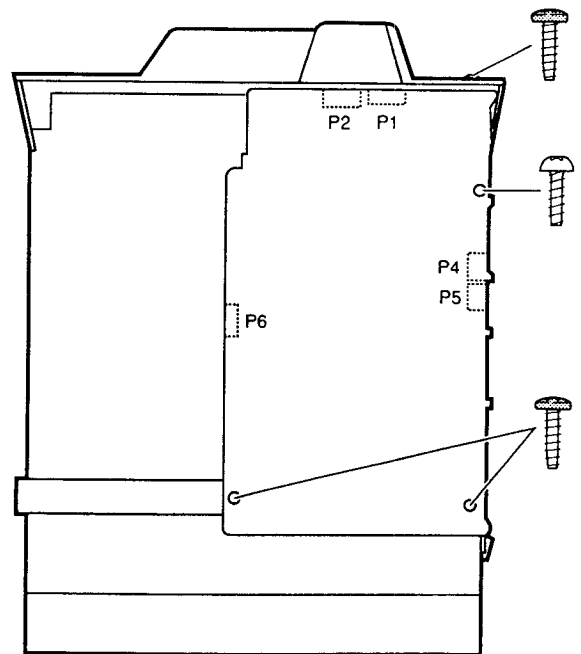

Fig.3-2

### 3-4.REMOVAL OF THE TRAY BLOCK

- 1) Remove the MAIN PCB.
- 2) Slide the GEAR HOLDER RETAINING SCREW in the direction of the arrow and pull out the TRAY BLOCK slowly.
- 3) Remove the MAIN PCB HOLDER RETAINING SCREWS then remove the MAIN PCB HOLDER and the BRACKETS on both side.
- 4) Remove the TRAY BLOCK.

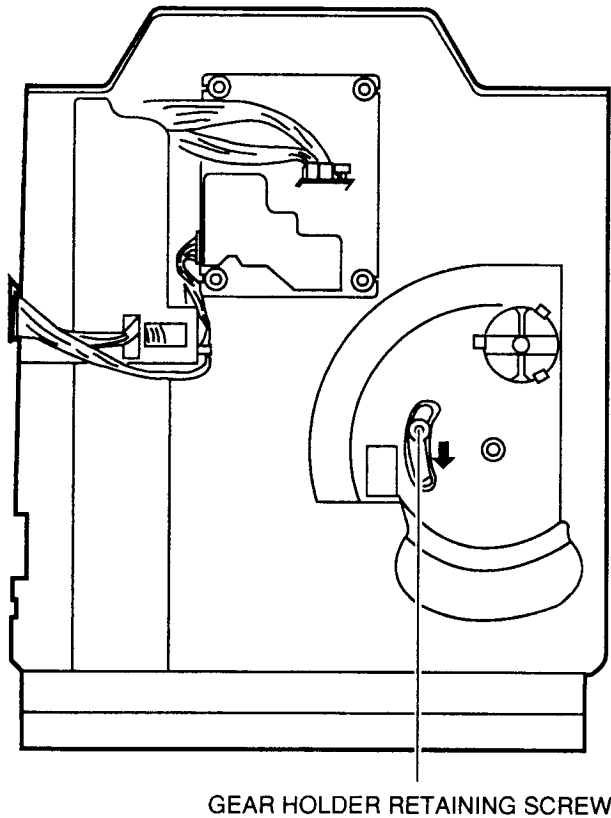

Fig.3-3

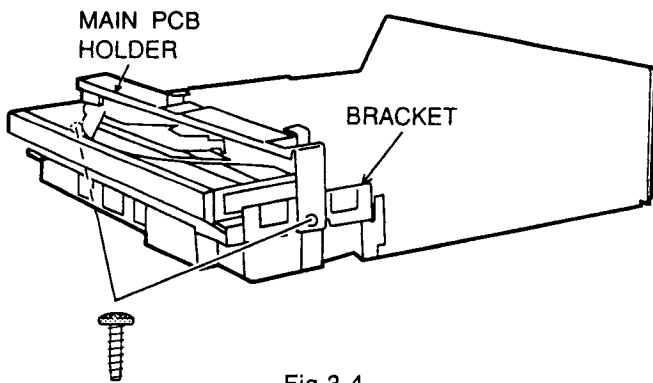

Fig.3-4

### 3-5.REPLACEMENT OF THE PICK UP BLOCK

- 1) Remove the TRAVERSE MECHA.
- 2) Push the Ⓐ stopper in the right direction and pull the SLIDE SHAFT in the forward direction to remove the PICK UP BLOCK, then replace the PICK UP BLOCK.
- 3) Reassemble in the reverse order.

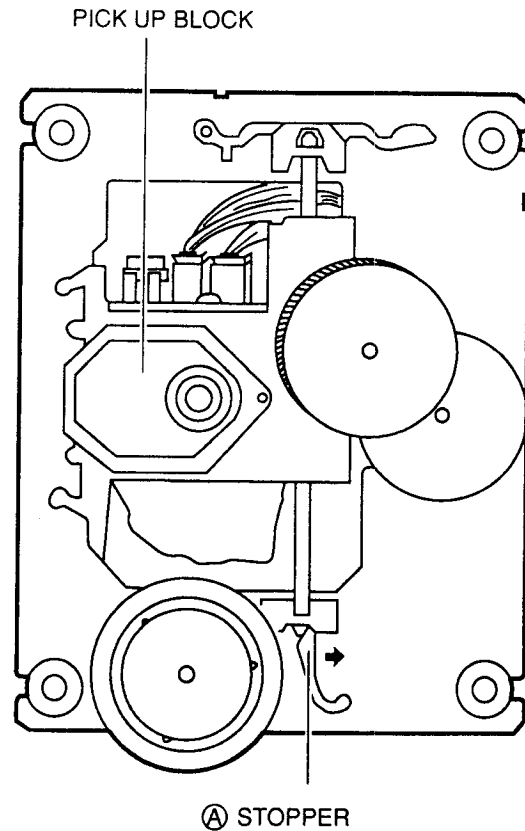

Fig.3-5

### 3-6.REPLACEMENT OF THE SPINDLE MOTOR

Replacement of the SPINDLE MOTOR itself is not recommended, because the adjustment of the TURN TABLE height is quite critical and necessitating the use of a special jig.

### 3-7. REPLACEMENT OF THE SLED MOTOR

- 1) Remove the TRAVERSE MECHA.
- 2) Remove the MOTOR PCB.
- 3) Remove the SLED MOTOR RETAINING Ⓞ SCREWS, then replace the SLED MOTOR.
- 4) Reassemble in the reverse order.

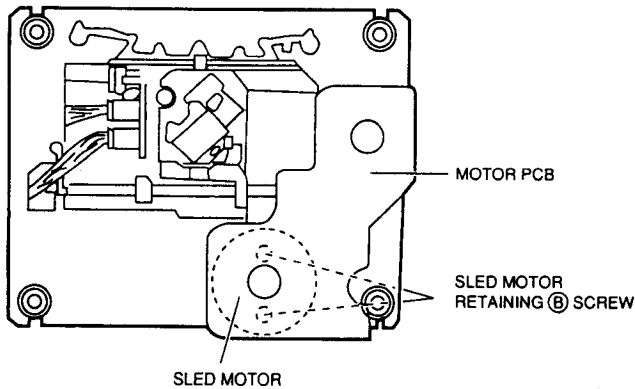
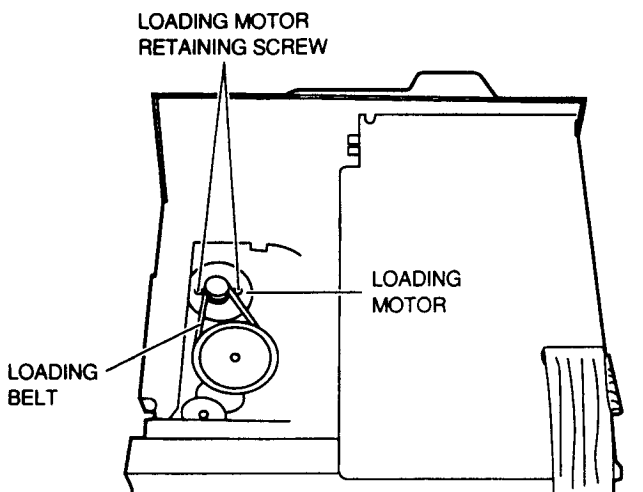

Fig.3-6

### 3-8. REPLACEMENT OF THE LOADING MOTOR

- 1) Push the GEAR HOLDER RETAINING SCREW in the direction of the arrow, then pull out the TRAY BLOCK.
- 2) Remove the LOADING BELT and the LOADING MOTOR RETAINING SCREWS.
- 3) Unsolder the lead wires of the LOADING MOTOR with a soldering iron.
- 4) While opening the LOADING MOTOR'S THREE RETAINING HOOKS, remove and replace the LOADING MOTOR.
- 5) Reassemble in the reverse order.



### 3-9. REPLACEMENT OF THE TABLE MOTOR

- 1) Remove the MAIN PCB.
- 2) Remove the TRAY BLOCK.
- 3) Remove the DISC HOLDER RETAINING SCREW then remove DISC HOLDER.
- 4) Remove the GEAR COVER then remove the TABLE GEAR (B) and WORM WHEEL TABLE GEAR.
- 5) Unsolder the lead wires of the TABLE MOTOR.
- 6) Remove the TABLE MOTOR while opening the TABLE MOTOR RETAINING HOOK, then replace the TABLE MOTOR.
- 7) Reassemble in the reverse order.

NOTE: 1) When reassembling, make sure that the TABLE GEAR (A)'s hole is aligned with the reference hole on the LOADING TRAY.  
 2) When installing the DISC HOLDER on the LOADING TRAY, make sure to place the DISC HOLDER so that "DISC 3" is facing upward ("DISC 2" faces right and "DISC 1" faces left accordingly).

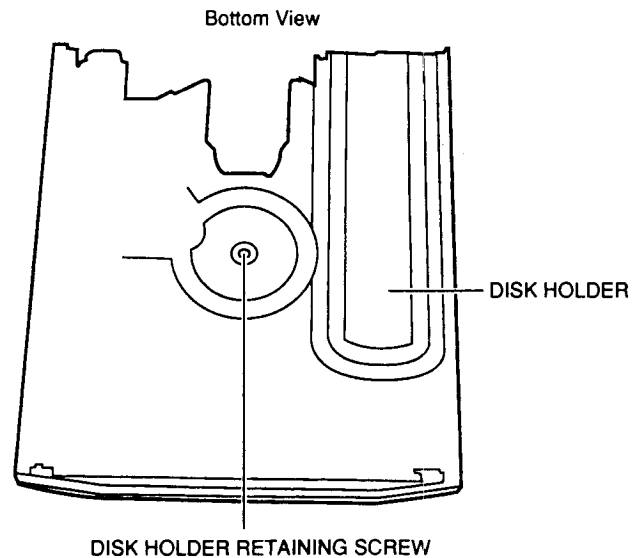
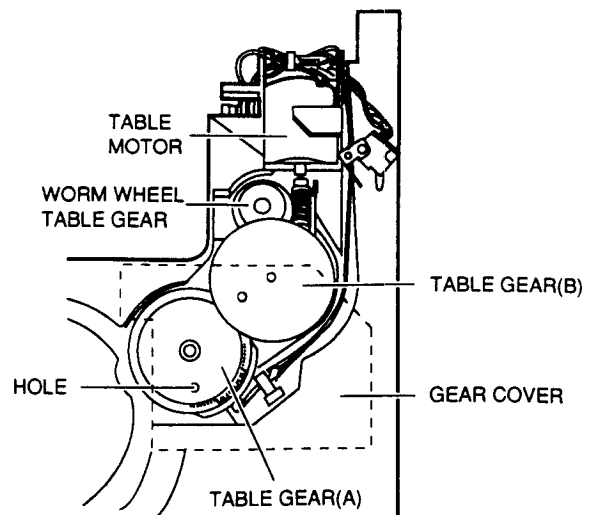

Fig.3-8



# ELECTRICAL ADJUSTMENT

When making adjustments 1 - 5, load a test disc as follows.

First setting the unit to the test mode 1, press the ►/■ button to open the disc tray and place a SONY TYPE 3 test disc on the DISC 1 holder. Press the ►/■ button again to close the tray. Adjustments can now be made.

**P1 ADJUSTMENT**  
TEST DISC  
MODE or TEST mode  
TEST POINT and ADJUSTMENT parts.  
REMARK (\*), RESULT (\*)

Test point      ADJ. part

**5 FOCUS OFF-SET**

1. Test disc SONY TYPE 3 (AT-711881)
2. Test mode 2 and 1
3. FE (TP-2) / VR 5
4. •Connect a digital DC voltmeter to the TP 2 (FE) and check the voltage A in the test mode 2, then press STOP button and adjust the voltage B so that the reading on the digital DC voltmeter is the same as voltage A.  
\*A=B

**4 TRACKING SERVO GAIN**

1. Test disc SONY TYPE 3 (AT-711881)
2. Test mode 5
3. P1 @ pin / VR 4
4. •Connect an oscilloscope to the P1 connector @ pin.  
\*500 to 800mVp-p

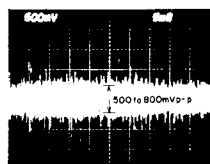
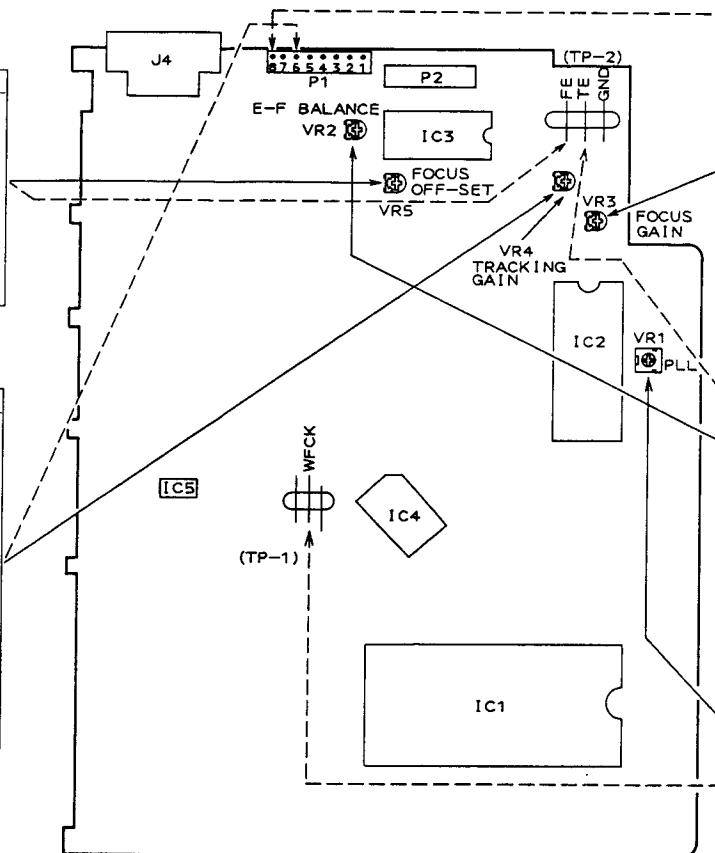
MAIN PCB  
FRONT

**3 FOCUS SERVO GAIN**

1. Test disc SONY TYPE 3 (AT-711881)
2. Test mode 5
3. P1 @ pin / VR 3
4. •Connect an oscilloscope to the P1 connector @ pin.  
\*1.0 to 1.4Vp-p

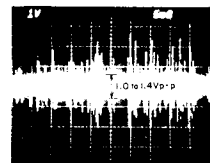

**2 E-F BALANCE**

1. Test disc SONY TYPE 3 (AT-711881)
2. Test mode 3
3. TE (TP 2) / VR 2
4. •Connect an oscilloscope to the TP 2 (TE)  
\*A=B



**1 VCO**

1. —
2. Test mode 1
3. WFCK (TP-1) / VR 1
4. •Connect a frequency counter to the TP 1 (WFCK).  
\*7,350 ±10Hz

MODE	HOW TO SET EACH MODE	FUNCTION	LED 1	LED 2	LED 3	MUSIC CALENDAR
1	While pressing the ■ and ►/■ buttons, insert the power cord.	•Indicates that unit is set into the TEST mode.	ON	OFF	OFF	1
2	Press the ▲ OPEN/CLOSE DISC 1 button	•FOCUS SERVO is on.	OFF	ON	OFF	2
3	Press the ▲ OPEN/CLOSE DISC 2 button	•CLV-S SERVO is on.	ON	ON	OFF	3
4	Press the ▲ OPEN/CLOSE DISC 3 button	•TRACKING SERVO is on.	OFF	OFF	ON	4
5	Press the PLAY ► DISC 1 button	•CLV-A and SLED SERVO are on.	ON	OFF	ON	5
6	Press the PLAY ► DISC 2 button	•ANTI SHOCK is on	OFF	ON	ON	6

- The disc tray can be opened or closed by pressing the ►/■ button (during any mode). After opening the tray, closing it will move the pick up to the inward position and return the unit to the TEST MODE 1.
- Pressing the ■ button will return the unit to the TEST MODE 1 regardless of the test mode presently engaged. However, the pick up will not be moved.
- Test modes can be selected directly.

# PARTS LIST

## ATTENTION

When placing an order for parts, be sure to list Part No., Model No. and the description of each part. Otherwise, the non-delivery of the part or the delivery of a wrong part may result. Please make sure that Part No. is correct when ordering. Not, a part different from the one you ordered may be delivered. The parts shown in Parts List of Preliminary Service Manual may have been the subject of changes, please use this Parts List for all future reference.

## HOW TO USE THIS PARTS LIST

Parts List lists those parts which are considered necessary for repairs. Other common parts, such as resistors and capacitors, are listed in the "Common List for Service Parts" from which these parts should be selected and stocked.

Recommended Spare Parts List shows those parts in the Parts List which are considered particularly important for service.

Parts not shown in the Parts List and "Common List for Service Parts" will not in principle be supplied.

Please read the Parts List.

Mechanism Block

## BASE BLOCK

No.	Description
T2023A320A	HEAD BASE BLOCK
H2206A010A	HEAD R/P PR4-8FU C
777876	PAN20×03STL CMT
636488	BID20×08STL CMT
402895	SP CS ANGLE ADJUST

b) PC Board

## 6. MAIN PC BOARD

Ref. No.	Part No.	Description
IC1	EI-324536	IC HD14049BP
IC2	EI-336801	IC MB8841-564M
C1A	EC-338399	C MMY V 223M 250AC [U,E,B,S]
C1B	EC-350949	C MMY V 223M 250DC [J]
C1C	EC-338397	C MMY V 223M 125AC [C,A]
X1	EI-318384	OSC XTAL NC-18C

Symbols for primary destination

[A] : AAL (U.S.A) [S] : SAA (Australia)  
 [B] : BEAB (England) [U] : U/T (Universal Area)  
 [C] : CSA (Canada)  
 [E] : CEE (Europe) [V] : VDE (Germany)  
 [J] : JPN (Japan) [Y] : Custom Version

SP (Service Parts) Classification

These reference symbols correspond with component symbols in the Schematic Diagrams.

Available PC Board Blocks are listed separately.

Part No. is known, Parts Index at end of Parts List can be used to locate where that part is shown in Parts

reference No. listed at right of Part No.

## WARNING

INDICATES SAFETY CRITICAL COMPONENTS. FOR CONTINUED SAFETY, REPLACE SAFETY CRITICAL COMPONENTS ONLY WITH MANUFACTURER'S RECOMMENDED PARTS.

## AVERTISSEMENT

INDIQUE LES COMPOSANTS CRITIQUES DE SÉCURITÉ. POUR MAINTENIR LE DEGRÉ DE SÉCURITÉ DE L'APPAREIL, NE REMPLACER QUE DES PIÈCES RECOMMANDÉES PAR LE FABRICANT.

## 1. RECOMMENDED SPARE PARTS

We suggest you to stock the following Recommended Spare Part items listed below since they can cover most of the routine service.

Ref.No.	Part No.	Description
1	*BB-408757N1	MECHA TRAVERSE KSM-2101ABM
2	BM-733203J	MOTOR GEAR ASSY (MB)
3	BM-374198	MOTOR RF-370CA-15370
4	BM-408752M	MOTOR RF-500TB-14415
5	*BO-394728J	PICK UP KSS-210A
6	ED-408651J	D LED SEL2913K ORANGE
7	ED-307572	D SILICON H 1SS131
8	*ED-511907	D SILICON 1N4002 100/1.0A
9	ED-408721J	D ZENER H HZS2B3
10	ED-408720J	D ZENER H HZS3C1
11	ED-408719J	D ZENER H HZS4C2
12	ED-403743J	D ZENER H HZS6B3
13	*ED-400171J	D ZENER H HZS6C2L
14	EH-408654J	COMP R RGLLE10T 223J
15	EH-404307J	COMP R RGLLE13X 223J
16	EH-408656J	COMP R RGLLE6X 472J
17	EI-330352	IC BA6109
18	EI-389264J	IC BA6209N
19	EI-390112J	IC CXA1081S
20	EI-390120J	IC CXA1082BS
21	EI-403497J	IC CXD11670
22	EI-387938J	IC HD74LS05P
23	EI-408657J1	IC M38002M4-126SP MXA1CD2
24	EI-393325J	IC M5218AP
25	EI-213390	IC NJM4558D
26	EI-408658J	IC PCM67U
27	EI-390149J	OSC CE CST4.23MGW 4.230MHZ
28	EI-381139J	OSC XTAL HC-49/U 16934.400KHZ
29	ES-733205J	SW LEAF
30	ES-408754M	SW LEAF LSA-1119H
31	ES-408755M	SW LEAF LSA-2127E
32	ES-394427J	SW TACT SOR-133HS T05
33	ET-369248	TR DTC114YS
34	ET-360399	TR DTC114TS
35	ET-354365	TR DTC114YS
36	ET-354371	TR DTC124ES
37	ET-354364	TR DTC143TS
38	ET-353899	TR 2SA1317 S,T,U
39	ET-394919J	TR 2SB1329 Q,R T05
40	*ET-388338J	TR 2SB1425 S,E
41	ET-397160J	TR 2SC3330 R,S,T,U,V
42	ET-379239	TR 2SD1380 Q,R
43	*ET-396072J	TR 2SD2159 V,W
44	MA-733202J	TURNTABLE CHASSIS ASSY (MB)

## 2. CD MECHANISM

Ref.No.	Part No.	Description
1	BM-408752M	MOTOR RF-500TB-14415
2	MR-407764M	PULLEY (SG)
3	ES-408755M	SW LEAF LSA-2127E
4	ES-408754M	SW LEAF LSA-1119H
5	ZS-343082	PT BR26X08STL CMT
6	*BB-408757N1	MECHA TRAVERSE KSM-2101ABM
7	MS-733198J	SLIDE SHAFT
8	ZG-733199J	SP COMPRESSION
9	MZ-733200J	CENTER RING (LO)
10	*BO-394728J	PICK UP KSS-210A
11	MZ-733201J	GEAR (A)
12	MA-733202J	TURNTABLE CHASSIS ASSY (MB)
13	BM-733203J	MOTOR GEAR ASSY (MB)
14	EA-733204J	MOTOR P C BOARD (6P)
15	ES-733205J	SW LEAF
16	EJ-733206J	CONNECTOR 6P
17	ZS-477876	PAN20X03STL CMT
18	EW-408749M	WIRE ASSY YMC-02 PU1 8P
19	EW-408750M	WIRE ASSY YMC-02 PU2 8P
20	EW-408751M	WIRE ASSY YMC-02 TRAVERSE 6P
21A	MB-407746M1	INSULATOR (SG)
21B	MB-411982M1	INSULATOR (B) (SG)
22	MZ-407745M1	HOLDER TRAVERSE (SG)
23	ZW-409219M	PW23X100X100STL BZN (SG)
24	ZS-390395J	BT BID20X10STL BZN
25	ZS-407886M	BT PAN30X08STL BZN C100 (SG)
26	BL-409250M	SG HOLDER GEAR PART
27	MZ-407734J1	GEAR LOADING (B)
28	MZ-407733M	GEAR LOADING (A) (SG)
29	MZ-407783J1	PULLEY GEAR
30	MB-407767M	BELT LOADING (SG)
31	MZ-410907J1	CLAMPER (B)
32	MZ-408753J	MAGNET FM30X17X5.2 2P
33	ML-407765J	LEVER SW LOADING
34	SC-407748M	TRAY LOADING (SG)
35	BM-374198	MOTOR RF-370CA-15370
36	MZ-407740J	WORM TABLE
37	MZ-407739M	GEAR WORM WHEEL TABLE (SG)
38	MZ-407737M	GEAR TABLE (A) (SG)
39	MZ-407738M	GEAR TABLE (B) (SG)
40	ES-408758M	SW LEVER SSCTL-S-R
41	ZG-407741M	SP PLATE HOLDER DISK (SG)
42	ML-407742M	LEVER SW (SG)
43	SZ-407750M	COVER GEAR (SG)
44	MZ-407749M	HOLDER DISK (SG)
45	ZW-396336M	PW30X150X080STL CMT (SG)
46	ZS-331182	BT BID30X08STL BNI
47	MR-407755M	ROLLER (SG)
48	MS-411215J	SHAFT WORM

## NOTE:

Parts will not be supplied if they are not listed in the parts list, even if they appear on the assembling illustrations with reference No.

**CD MECHANISM**

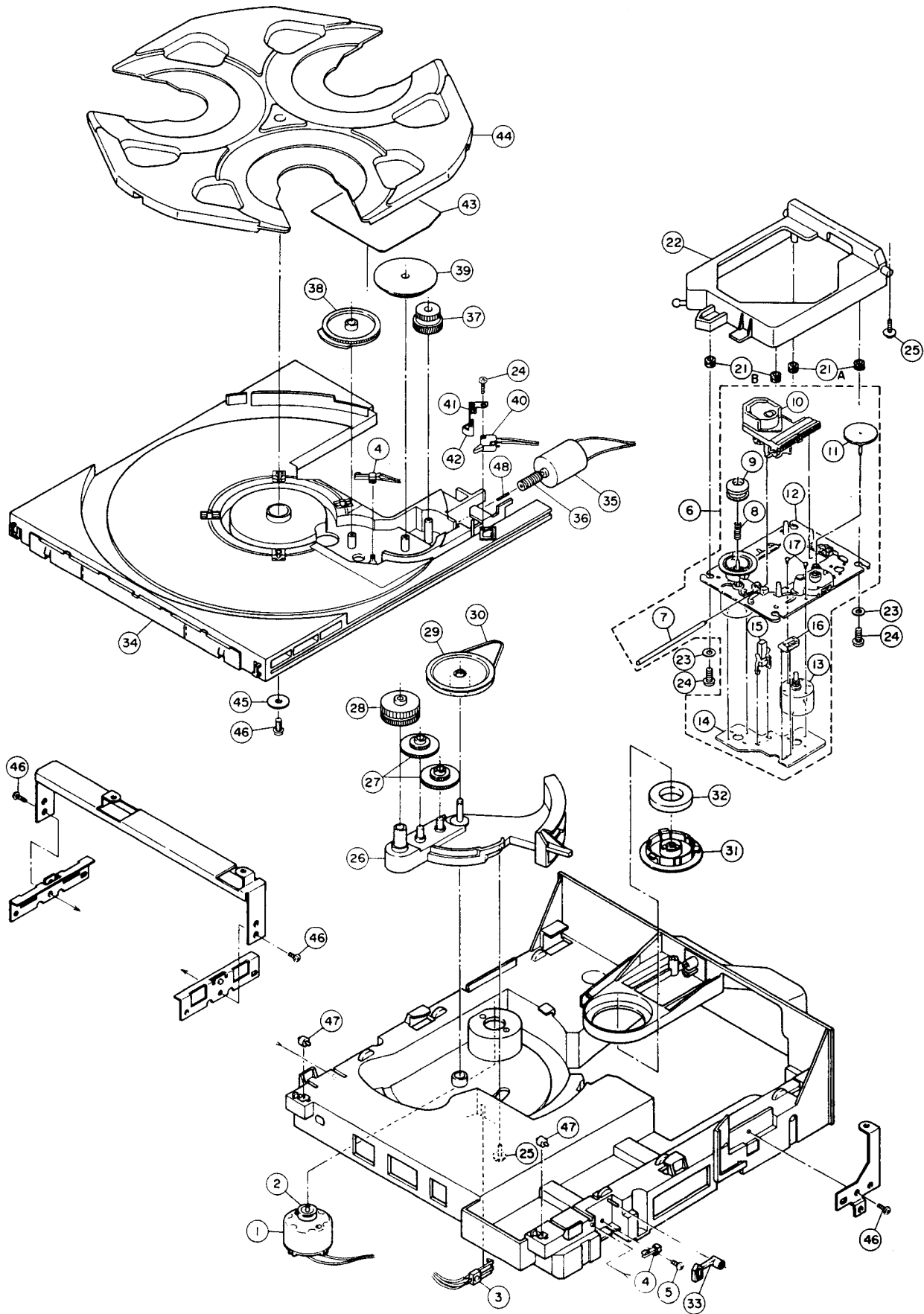

### 3. P.C BOARD BLOCK

Ref.No.	Part No.	Description
1	BA-P2069T030B	ML PC (#) CD BLK CD-750/ML

PC (#) CD BLK CONSISTS OF FOLLOWING P.C BOARD.

- MAIN P.C BOARD
- FRONT P.C BOARD

### 4. MAIN P.C BOARD

Ref.No.	Part No.	Description
D1	*ED-511907	D SILICON 1N4002 100/1.0A
D2	*ED-511907	D SILICON 1N4002 100/1.0A
D3	*ED-511907	D SILICON 1N4002 100/1.0A
D4	*ED-511907	D SILICON 1N4002 100/1.0A
D5	*ED-511907	D SILICON 1N4002 100/1.0A
D6	*ED-511907	D SILICON 1N4002 100/1.0A
D7	*ED-400171J	D ZENER H HZS6C2L
D9	*ED-400171J	D ZENER H HZS6C2L
D11	ED-307572	D SILICON H 1SS131
D12	ED-307572	D SILICON H 1SS131
D13	ED-307572	D SILICON H 1SS131
D14	ED-403743J	D ZENER H HZS6B3
D15	ED-400171J	D ZENER H HZS6C2L
D16	ED-408721J	D ZENER H HZS2B3
D17	ED-408720J	D ZENER H HZS3C1
D18	ED-408719J	D ZENER H HZS4C2
D19	ED-307572	D SILICON H 1SS131
D20	ED-307572	D SILICON H 1SS131
IB1	EH-404307J	COMP R RGL13X 223J
IB2	EH-408654J	COMP R RGL10T 223J
IB3	EH-408656J	COMP R RGL6X 472J
IC1	EI-408657J1	IC M38002M4-126SP MXA1CD2
IC2	EI-390120J	IC CXA1082BS
IC3	EI-390112J	IC CXA1081S
IC4	EI-403497J	IC CXD1167Q
IC5	EI-408658J	IC PCM67U
IC6	EI-393325J	IC M5218AP
IC7	EI-213390	IC NJM4558D
IC8	EI-387938J	IC HD74LS05P
IC9	EI-389264J	IC BA6209N
IC10	EI-330352	IC BA6109
J4	EJ-408660J	SOCKET CFG1111-0161 BLUE 11P
R50	*ER-394882J	R OMF V T05 FS 1/2W 1R2J
R53	*ER-394882J	R OMF V T05 FS 1/2W 1R2J
TR1	ET-397160J	TR 2SC3330 R,S,T,U,V
TR2	*ET-396072J	TR 2SD2159 V,W
TR3	*ET-396072J	TR 2SD2159 V,W
TR4	*ET-396072J	TR 2SD2159 V,W
TR5	ET-353899	TR 2SA1317 S,T,U
TR6	*ET-388338J	TR 2SB1425 S,E
TR7	ET-353899	TR 2SA1317 S,T,U
TR8	ET-397160J	TR 2SC3330 R,S,T,U,V
TR9	ET-360399	TR DTC114TS
TR10	ET-354365	TR DTC114YS
TR11	ET-397160J	TR 2SC3330 R,S,T,U,V
TR12	ET-397160J	TR 2SC3330 R,S,T,U,V
TR13	ET-397160J	TR 2SC3330 R,S,T,U,V
TR14	ET-360399	TR DTC114TS
TR15	ET-360399	TR DTC114TS
TR16	ET-354371	TR DTC124ES
TR17	ET-354364	TR DTC143TS
TR18	ET-354364	TR DTC143TS
TR19	ET-369248	TR DTA114YS
TR21	ET-379239	TR 2SD1380 Q,R
TR22	ET-388338J	TR 2SB1425 S,E
TR23	ET-379239	TR 2SD1380 Q,R
TR24	ET-394919J	TR 2SB1329 Q,R T05
TR25	ET-396072J	TR 2SD2159 V,W
TR26	ET-388338J	TR 2SB1425 S,E
TR27	ET-396072J	TR 2SD2159 V,W
TR28	ET-388338J	TR 2SB1425 S,E
TR29	ET-354365	TR DTC114YS
TR30	ET-354365	TR DTC114YS
TR31	ET-354365	TR DTC114YS
VR1	EV-404260J	R S-FIX H RH0681C 0.30W 102
VR2	EV-358829	R S-FIX H RH0615C 0.10W 223

Ref.No.	Part No.	Description
VR4	EV-358829	R S-FIX H RH0615C 0.10W 223
VR5	EV-356576	R S-FIX H RH0615C 0.10W 472
X1	EI-381139J	OSC X'TAL HC-49/U 16934.400KHZ
X2	EI-390149J	OSC CE CST4.23MGW 4.230MHZ

### 5. FRONT P.C BOARD

Ref.No.	Part No.	Description
D301	ED-408651J	D LED SEL2913K ORANGE
D302	ED-408651J	D LED SEL2913K ORANGE
D303	ED-408651J	D LED SEL2913K ORANGE
TS301	ES-394427J	SW TACT SOR-133HS T05
TS302	ES-394427J	SW TACT SOR-133HS T05
TS303	ES-394427J	SW TACT SOR-133HS T05
TS304	ES-394427J	SW TACT SOR-133HS T05
TS305	ES-394427J	SW TACT SOR-133HS T05
TS306	ES-394427J	SW TACT SOR-133HS T05
TS307	ES-394427J	SW TACT SOR-133HS T05
TS308	ES-394427J	SW TACT SOR-133HS T05
TS309	ES-394427J	SW TACT SOR-133HS T05
TS310	ES-394427J	SW TACT SOR-133HS T05

### 6. FINAL ASSEMBLY

Ref.No.	Part No.	Description
1	SA-394136M	CUSHION FOOT (SG)
2	SA-407840M	CUSHION FOOT REAR (SG)
3	SP-408026J	PANEL FRONT
4	SE-408024M	ESCUTCHEON FRONT (SG)
5	SB-408027M	BUTTON OP (SG)
6	SB-408028M	BUTTON OPEN (SG)
7	ZS-331182	BT BID30X08STL BNI
8	ZS-394412M	BT BID30X08STL BZN PROJECTION
9	SP-408022M	COVER UPPER (SG)
10	SP-408029J	COVER TRAY
11	SC-408030M	CAP TRAY L (SG)
12	SC-408031M	CAP TRAY R (SG)
13	SM-409218J	NAME PLATE AKAI-S
14	ZW-408744J	PUSH NUT SPN-2

#### NOTE:

Parts will not be supplied if they are not listed in the parts list, even if they appear on the assembling illustrations with reference No.

**FINAL ASSEMBLY**

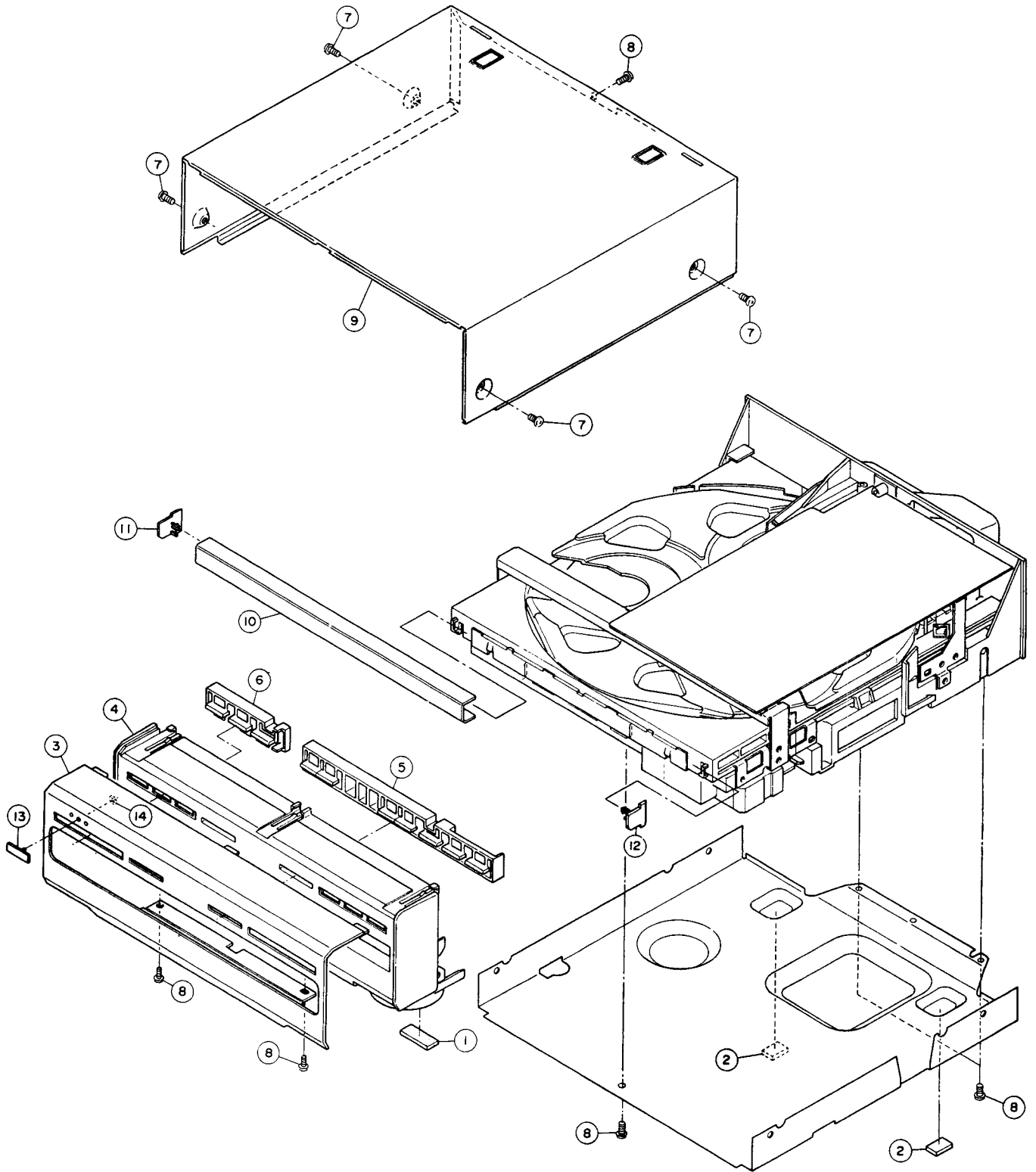



# INDEX

Part No.	Ref. No.	Part No.	Ref. No.	Part No.	Ref. No.	Part No.	Ref. No.
BAP2069T030B	3-1	ET354371	4-TR16	ZS343082	2-5		
BB408757N1	2-6	ET360399	4-TR9	ZS390395J	2-24		
BL409250M	2-26	ET360399	4-TR14	ZS394412M	6-8		
BM374198	2-35	ET360399	4-TR15	ZS407886M	2-25		
BM408752M	2-1	ET369248	4-TR19	ZS477876	2-17		
BM733203J	2-13	ET379239	4-TR21	ZW396336M	2-45		
BO394728J	2-10	ET379239	4-TR23	ZW408744J	6-14		
EA733204J	2-14	ET388338J	4-TR6	ZW409219M	2-23		
ED307572	4-D11	ET388338J	4-TR22				
ED307572	4-D12	ET388338J	4-TR26				
ED307572	4-D13	ET388338J	4-TR28				
ED307572	4-D19	ET394919J	4-TR24				
ED307572	4-D20	ET396072J	4-TR2				
ED400171J	4-D7	ET396072J	4-TR3				
ED400171J	4-D9	ET396072J	4-TR4				
ED400171J	4-D15	ET396072J	4-TR25				
ED403743J	4-D14	ET396072J	4-TR27				
ED408651J	5-D301	ET397160J	4-TR1				
ED408651J	5-D302	ET397160J	4-TR8				
ED408651J	5-D303	ET397160J	4-TR11				
ED408719J	4-D18	ET397160J	4-TR12				
ED408720J	4-D17	ET397160J	4-TR13				
ED408721J	4-D16	EV356576	4-VR5				
ED511907	4-D1	EV358829	4-VR2				
ED511907	4-D2	EV358829	4-VR3				
ED511907	4-D3	EV358829	4-VR4				
ED511907	4-D4	EV404260J	4-VR1				
ED511907	4-D5	EW408749M	2-18				
ED511907	4-D6	EW408750M	2-19				
EH404307J	4-IB1	EW408751M	2-20				
EH408654J	4-IB2	MA733202J	2-12				
EH408656J	4-IB3	MB407746M	2-21A				
EI213390	4-IC7	MB407767M	2-30				
EI330352	4-IC10	MB411992M	2-21B				
EI381139J	4-X1	ML407742M	2-42				
EI387938J	4-IC8	ML407765J	2-33				
EI389264J	4-IC9	MR407755M	2-47				
EI390112J	4-IC3	MR407764M	2-2				
EI390120J	4-IC2	MS411215J	2-48				
EI390149J	4-X2	MS733198J	2-7				
EI393325J	4-IC6	MZ407733M	2-28				
EI403497J	4-IC4	MZ407734J1	2-27				
EI408657J1	4-IC1	MZ407737M	2-38				
EI408658J	4-IC5	MZ407738M	2-39				
EJ408660J	4-J4	MZ407739M	2-37				
EJ733206J	2-16	MZ407740J	2-36				
ER394882J	4-R50	MZ407745M	2-22				
ER394882J	4-R53	MZ407749M	2-44				
ES394427J	5-TS301	MZ407763J1	2-29				
ES394427J	5-TS302	MZ408753J	2-32				
ES394427J	5-TS303	MZ410907J1	2-31				
ES394427J	5-TS304	MZ733200J	2-9				
ES394427J	5-TS305	MZ733201J	2-11				
ES394427J	5-TS306	SA394136M	6-1				
ES394427J	5-TS307	SA407840M	6-2				
ES394427J	5-TS308	SB408027M	6-5				
ES394427J	5-TS309	SB408028M	6-6				
ES394427J	5-TS310	SC407748M	2-34				
ES408754M	2-4	SC408030M	6-11				
ES408755M	2-3	SC408031M	6-12				
ES408758M	2-40	SE408024M	6-4				
ES733205J	2-15	SM409218J	6-13				
ET353899	4-TR5	SP408022M	6-9				
ET353899	4-TR7	SP408026J	6-3				
ET354364	4-TR17	SP408029J	6-10				
ET354364	4-TR18	SZ407750M	2-43				
ET354365	4-TR10	ZG407741M	2-41				
ET354365	4-TR29	ZG733199J	2-8				
ET354365	4-TR30	ZS331182	2-46				
ET354365	4-TR31	ZS331182	6-7				

## ABBREVIATIONS (COMPACT DISC)

ABBREVIATION	EXPLANATION	ABBREVIATION	EXPLANATION
A-D	Analog to Digital (Convertor)	Mb	Mega Bits
ADC	Analog to Digital (Convertor)	MDA	Mortor Drive Amplifier
BCD	Binary Code Decimal	MFM	Modified Frequency Modulation
BPI	Bits per Inch	MM	Mono-stable Multivibrator
CD	Compact Disc	M <sup>2</sup> FM	Modified Modified Frequency Modulation
CIRC	Cross Interleaving & Reed Solomon Coding	MOD2	Modulo 2 (Addition)
CLV	Constant Linear Velocity	MP	Microprocessor
CP	Clock Pulses	MSB	Most Significant Bit
CRCC	Cyclic Redundancy Check Codes	NA	Numerical Aperture
D Level	Decision Level	NRZ	Non Return to Zero
D-A	Digital to Analog (Convertor)	NRZ-1	Non Return to Zero Inverted
DAC	Digital to Analog (Convertor)	P	Parity Data
DAD	Digital Audio Disc	PAM	Pulse Amplitude Modulation
DEM	Dynamic Element Matching	PCM	Pulse Code Modulation
DPD	Differential Phase Detection	PD	Phase Detector
DSV	Digital Sum Value	PE	Phase Encode
EFM	Eight to fourteen Modulation	PLL	Phase Locked Loop
EX-OR	EXclusive OR	PNM	Pulse Number Modulation
FCI	Flux Changes per Inch	PPM	Pulse Phase Modulation
FIR	Finite Impulse Response	PWM	Pulse Width Modulation
FP	Front Pulse	Q	Parity Data
FPG	Front Pulse Gate	R, R <sub>1</sub> , R <sub>2</sub> , etc.	Data for Right Channel
f	Frequency of Sampling	RAM	Random Access Memory
GF	Galois Field	RPG	Rear Pulse Gate
H & V (Parity)	Horizontal & Vertical	SCOOP	Self Coupled Optical Pick-up
IIR	Infinite Impulse Response	S & H	Sample & Hold
kb	Kilo Bits	S/N	Signal to Noise Ratio
L, L <sub>1</sub> , L <sub>2</sub> , etc.	Data for Left Channel	SSG	Standard Signal Generator
LPF	Low Pass Filter	SYSCON	SYStem CONtrol
LSB	Least Significant Bit		

# AKAI

**MODEL MX-750**  
(TP-750, EA-750, PA-750, HX-750, CD-750)

**MODEL MX-950**  
(TP-750, EA-750, PA-950, HX-950, CD-750)

## **SCHEMATIC DIAGRAMS AND PC BOARDS**

### TABLE OF CONTENTS

<b>I. BLOCK DIAGRAMS</b>	
1. TP-750 .....	3
2. EA-750 .....	4
3. HX-750 DECK & OPERATION .....	5
4. HX-950 DECK (A) · (B) & OPERATION .....	6
5. CD-750 .....	7
<b>II. SCHEMATIC DIAGRAMS AND PC BOARDS</b>	
1. TP-750 CONTROL & FRONT .....	8
2. TP-750 TUNER .....	10
3. EA-750 FRONT .....	13
4. EA-750 MAIN & SUB .....	14
5. PA-750, 950 POWER SUPPLY & MAIN AMP .....	16
6. HX-750 .....	18
7. HX-950 .....	20
8. CD-750 MAIN & FRONT .....	22
<b>III. INFORMATION OF ICs</b> .....	24

Use these schematic diagrams and PC boards together with the provided service manual.

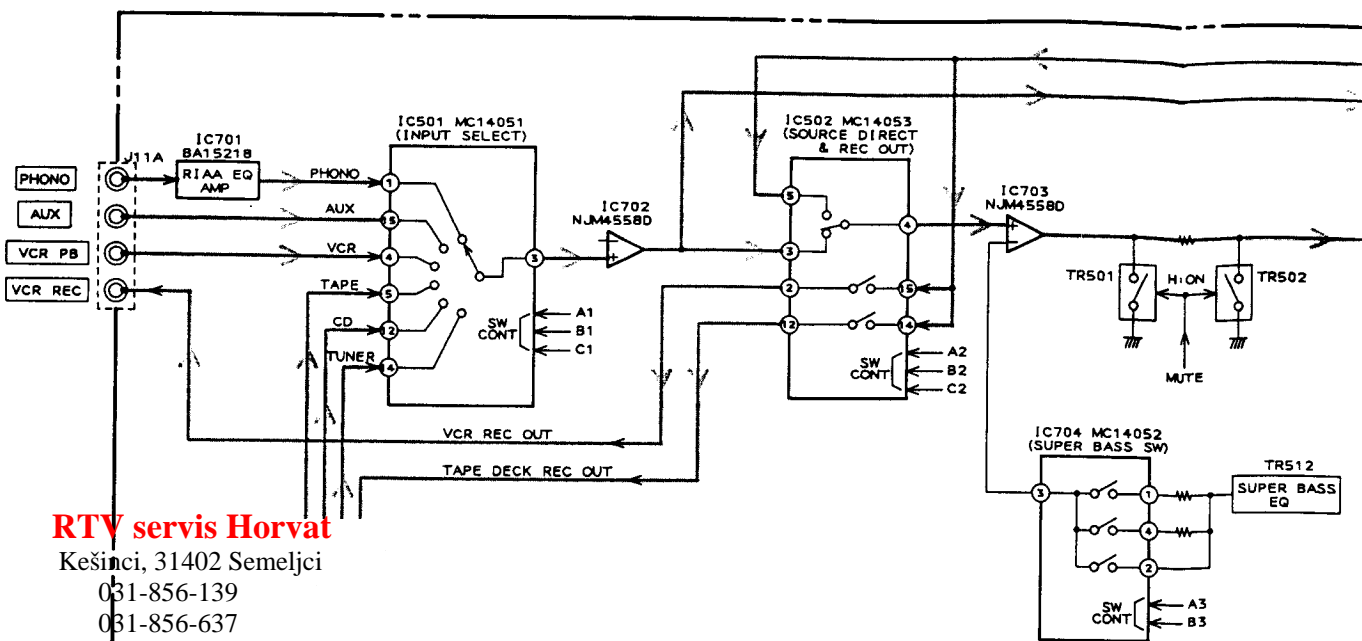

**RTV servis Horvat**

Kešinci, 31402 Semeljci

031-856-139

031-856-637

098-788-319

[rtv-servis-horvat@os.tel.hr](mailto:rtv-servis-horvat@os.tel.hr)

Croatia

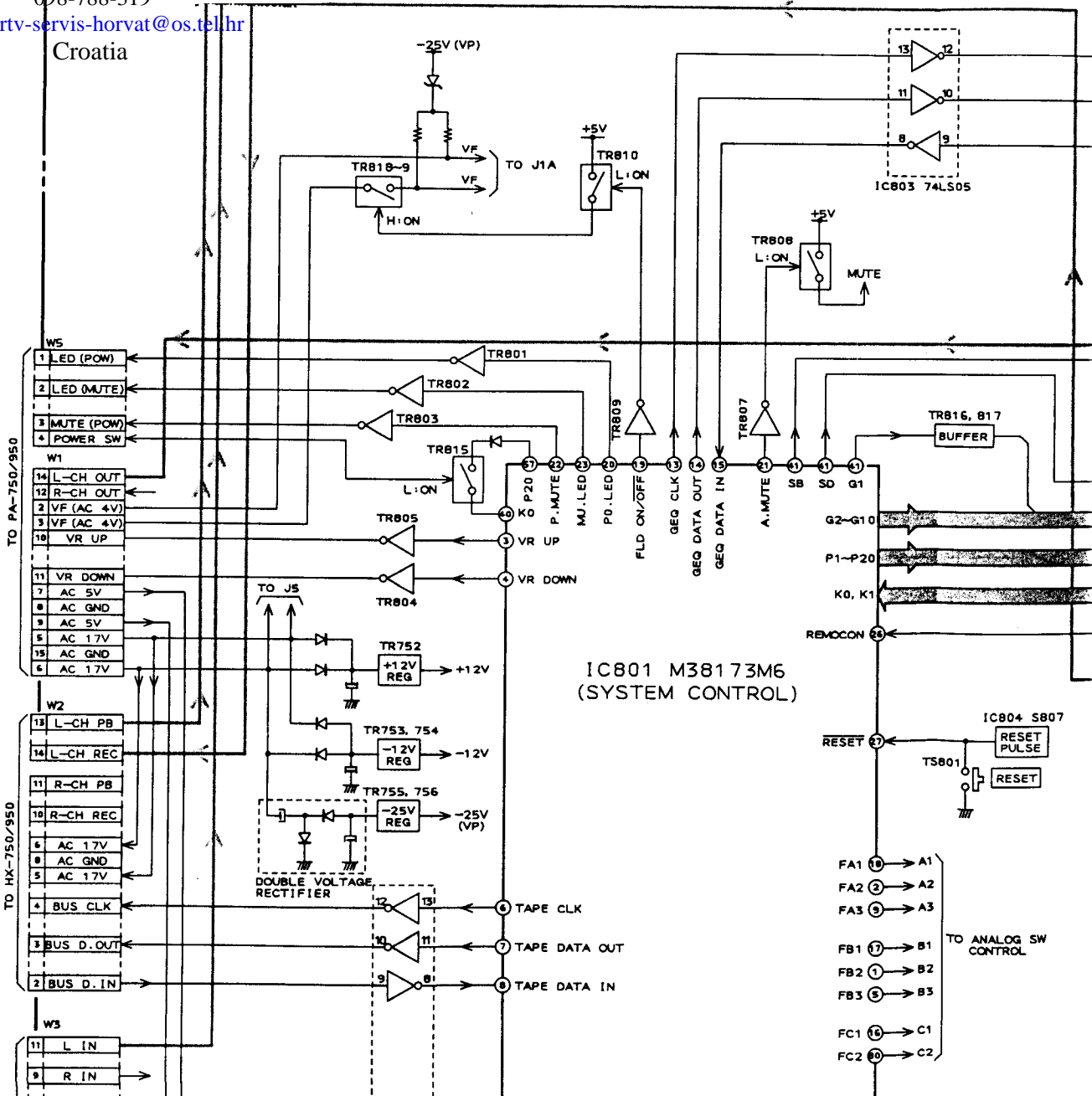

C

D

E

F

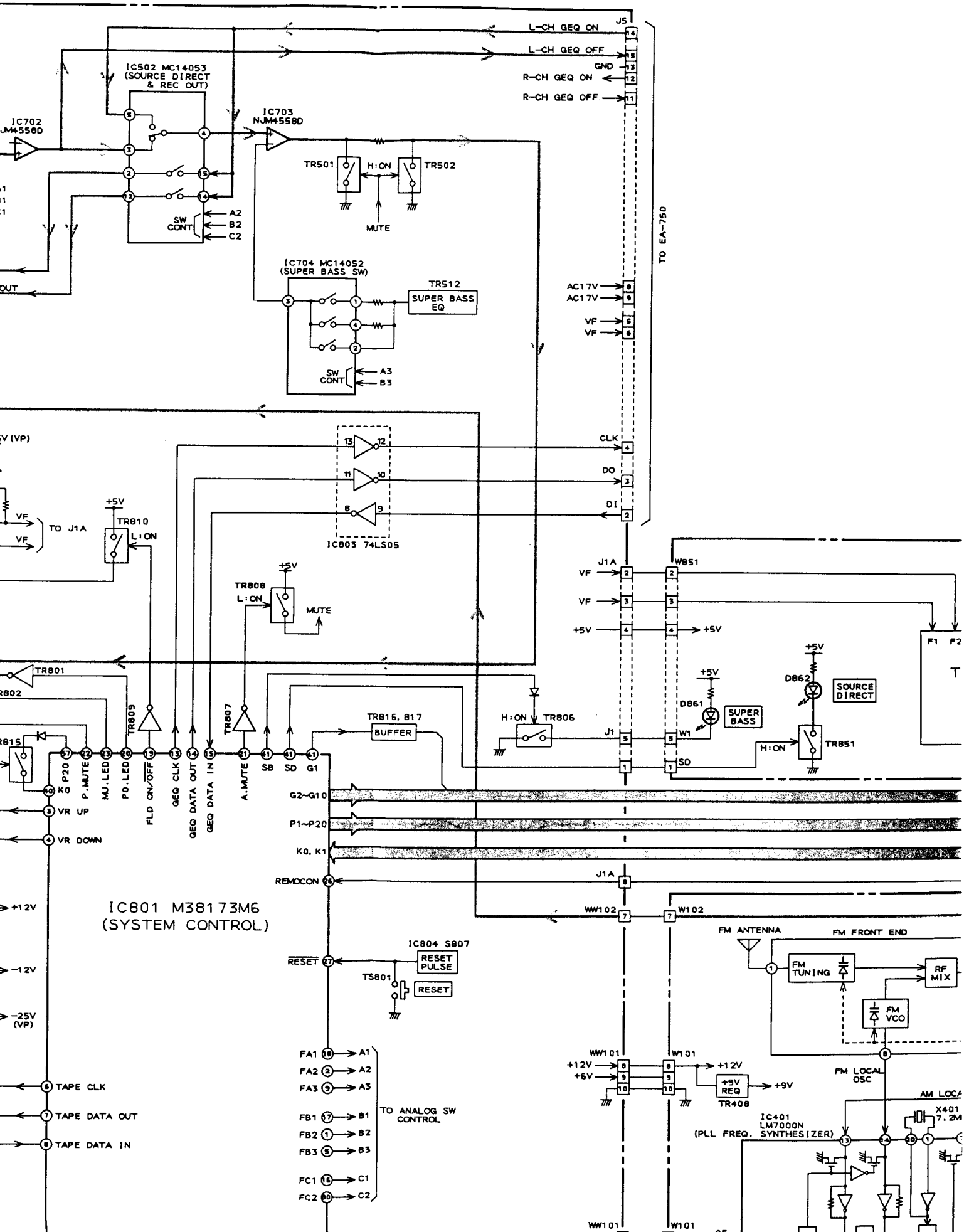

IC801 M38173M6 (SYSTEM CONTROL)

IC804 S807

RESET

RESET PULSE

RESET

- FA1 (10) → A1
- FA2 (2) → A2
- FA3 (9) → A3
- FB1 (17) → B1
- FB2 (1) → B2
- FB3 (6) → B3
- FC1 (15) → C1
- FC2 (20) → C2

TO ANALOG SW CONTROL

TO EA-750

FM ANTENNA

FM FRONT END

FM TUNING

RF MIX

FM VCO

FM LOCAL OSC

IC401 LM7000N (PLL FREQ. SYNTHESIZER)

X401 7.2M

AM LOCAL OSC

+12V

+6V

+9V REQ

+9V

WW101

WW101

VF

VF

+5V

H:ON

J1

SD

W1

SD

VF

VF

+5V

W102

W102

J1A

W101

W101

W101

W101

W101

W101

W101

W101

W101

W101

J5

L-CH GEQ ON

L-CH GEQ OFF

GND

R-CH GEQ ON

R-CH GEQ OFF

AC17V

AC17V

VF

VF

VF

VF

VF

VF

VF

VF

VF

VF

VF

VF

VF

VF

VF

VF

VF

VF

VF

VF

VF

VF

VF

VF

VF

VF

VF

VF

VF

VF

VF

VF

VF

VF

VF

VF

VF

VF

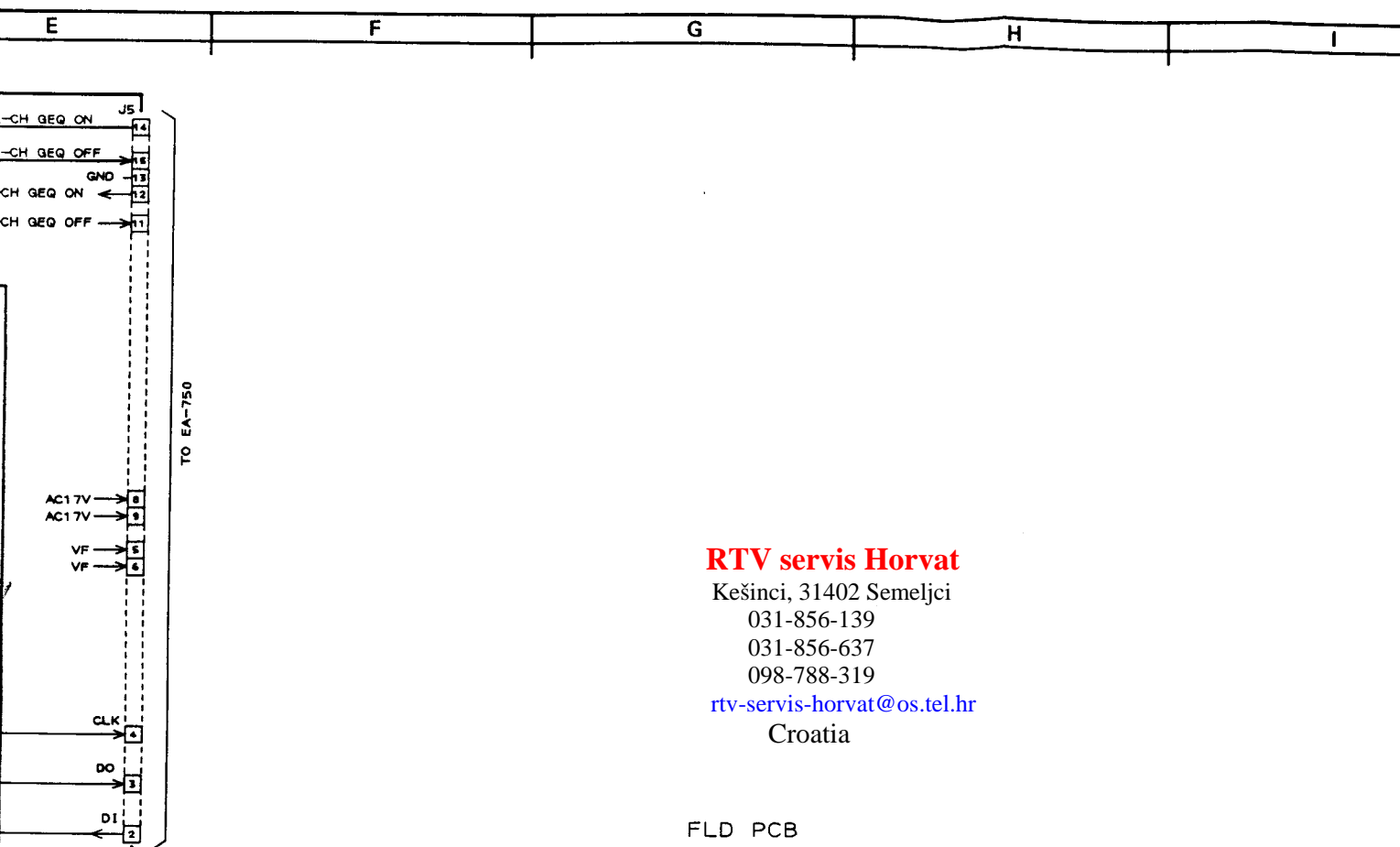

**RTV servis Horvat**  
 Kešinci, 31402 Semeljci  
 031-856-139  
 031-856-637  
 098-788-319  
[rtv-servis-horvat@os.tel.hr](mailto:rtv-servis-horvat@os.tel.hr)  
 Croatia

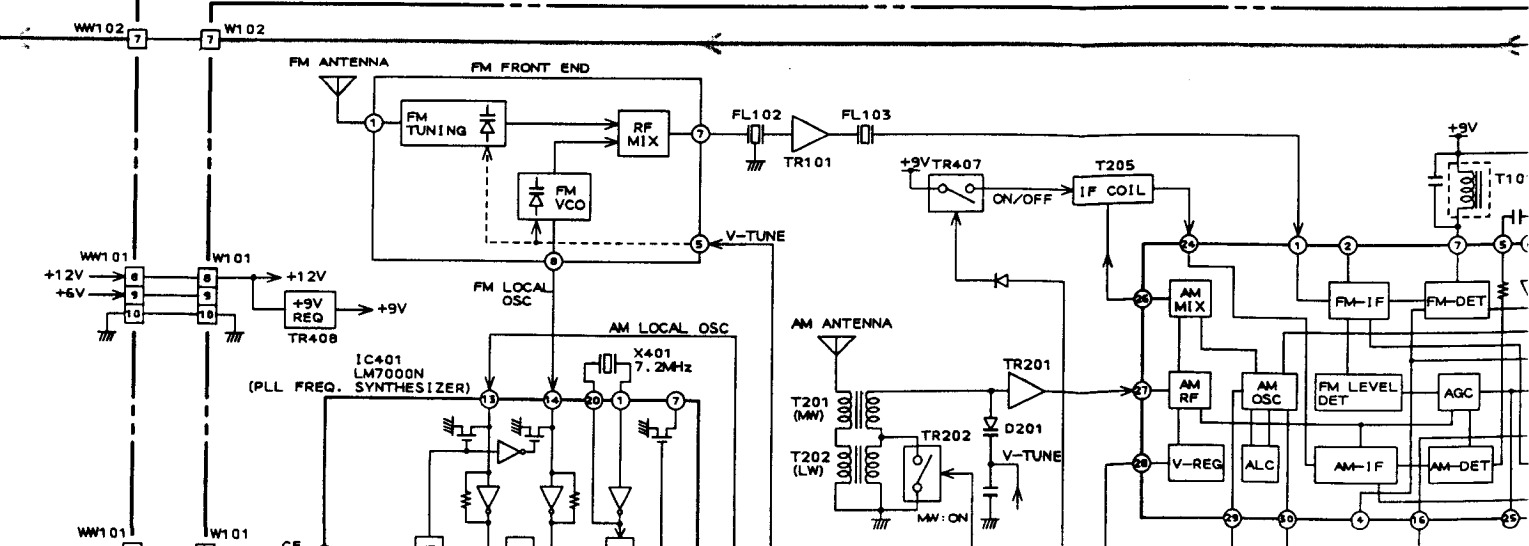
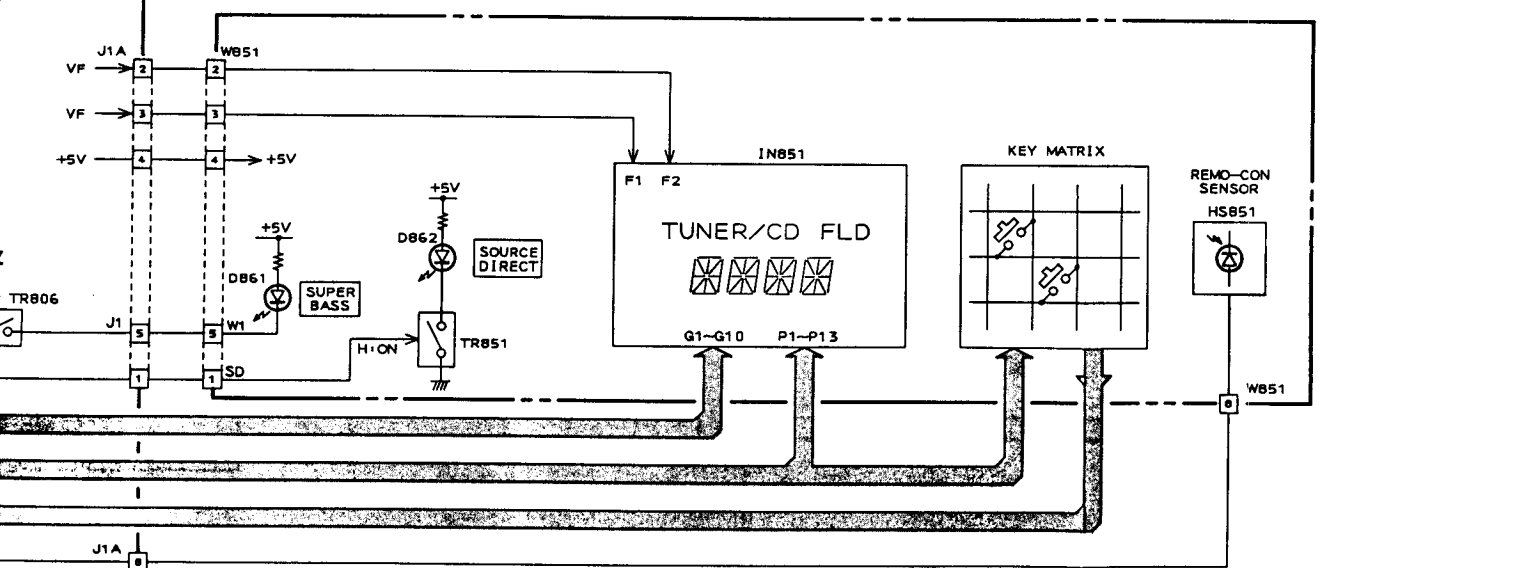

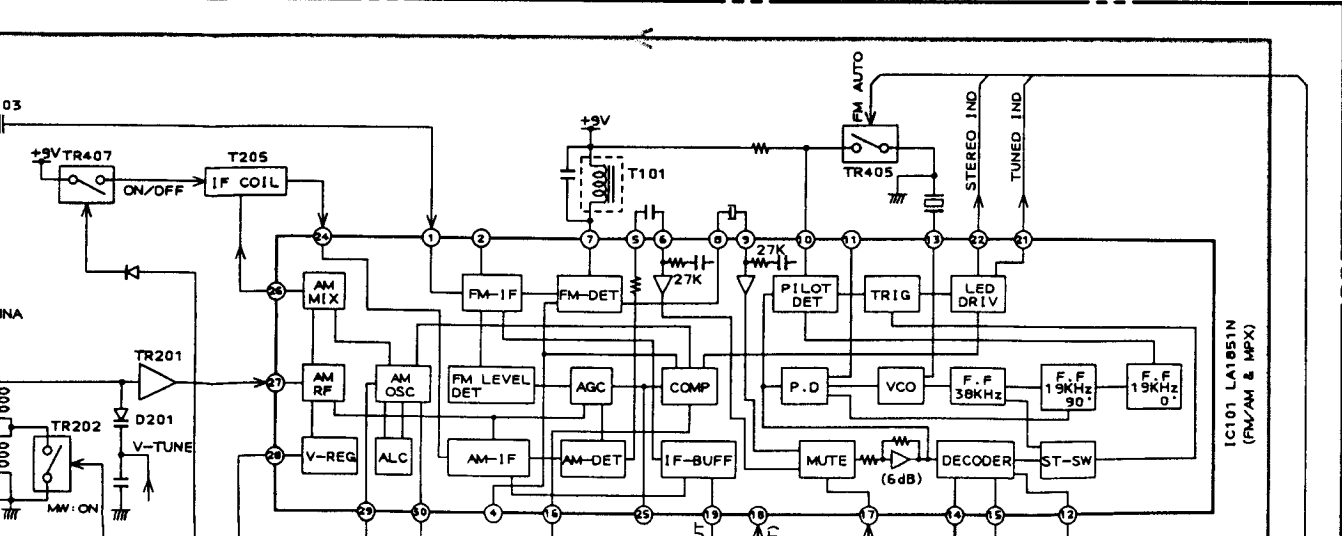
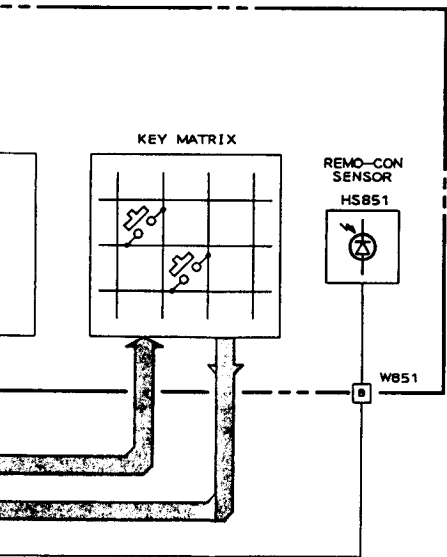

3

4

5

6

7

8

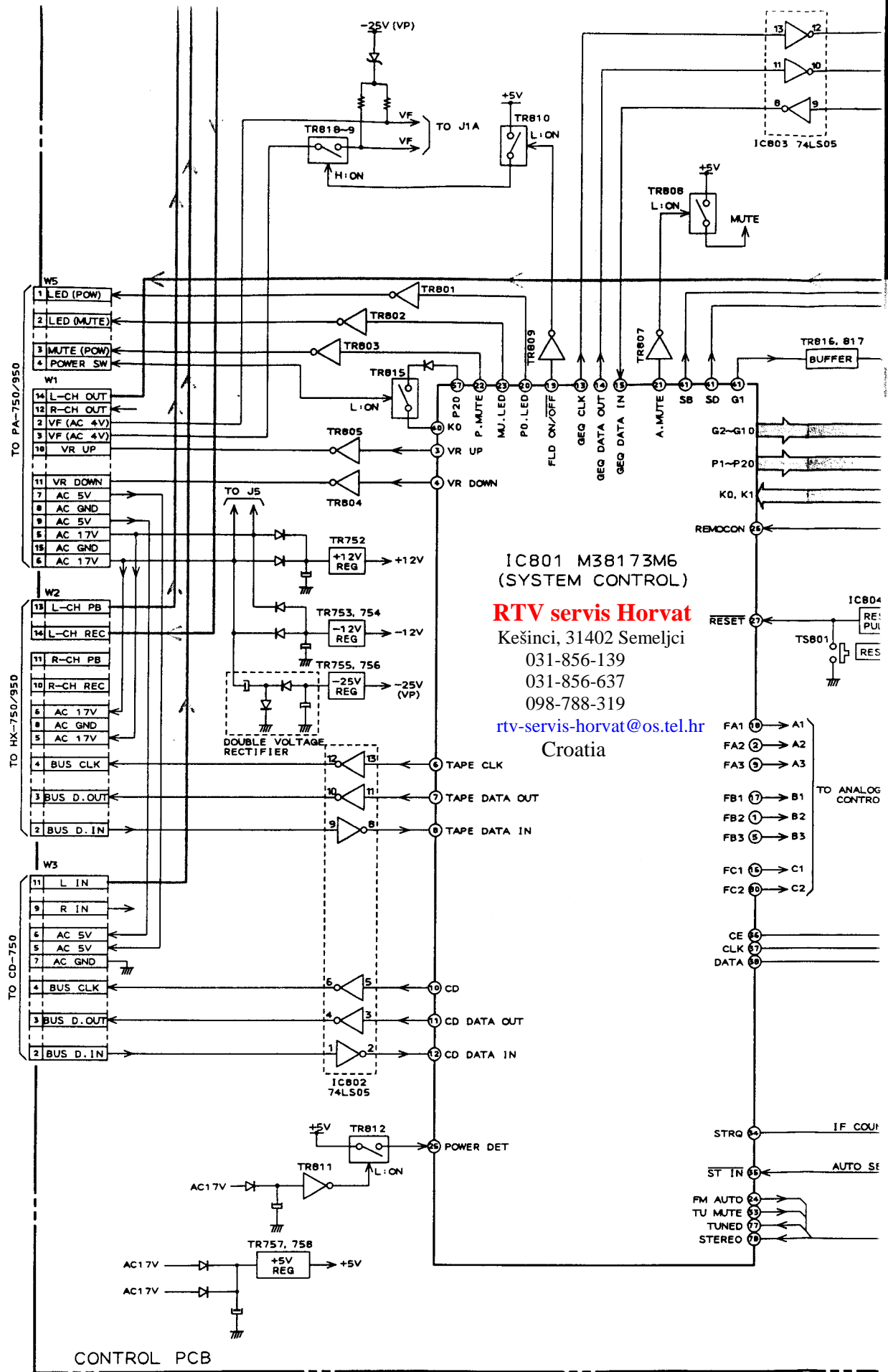

IC801 M38173M6  
(SYSTEM CONTROL)

**RTV servis Horvat**

Kešinci, 31402 Semeljci

031-856-139

031-856-637

098-788-319

[rtv-servis-horvat@os.tel.hr](mailto:rtv-servis-horvat@os.tel.hr)

Croatia

CONTROL PCB



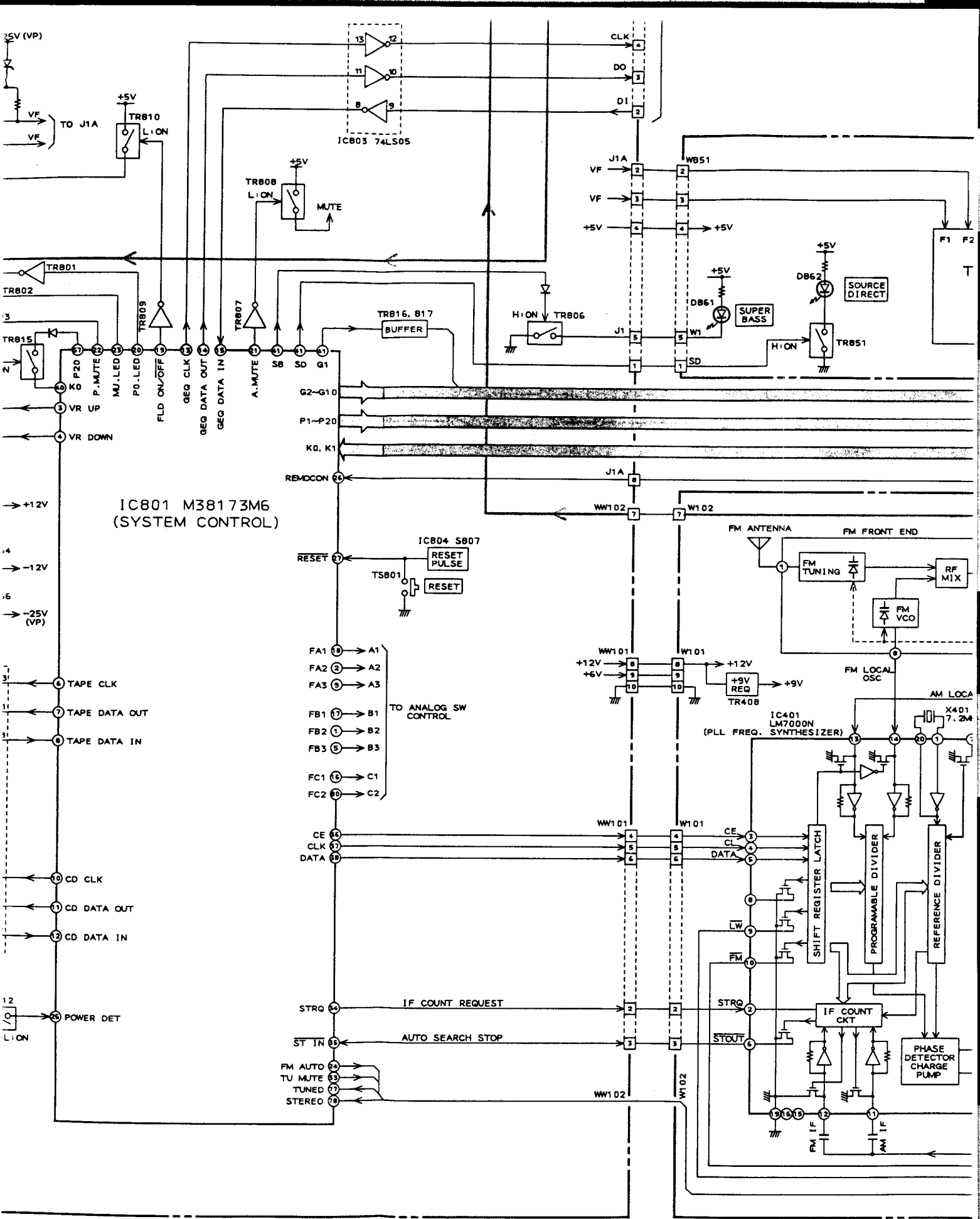

TUNER PCB

# RTV servis Horvat

Kešinci, 31402 Semeljci

031-856-139

031-856-637

098-788-319

[rtv-servis-horvat@os.tel.hr](mailto:rtv-servis-horvat@os.tel.hr)

Croatia

FLD PCB

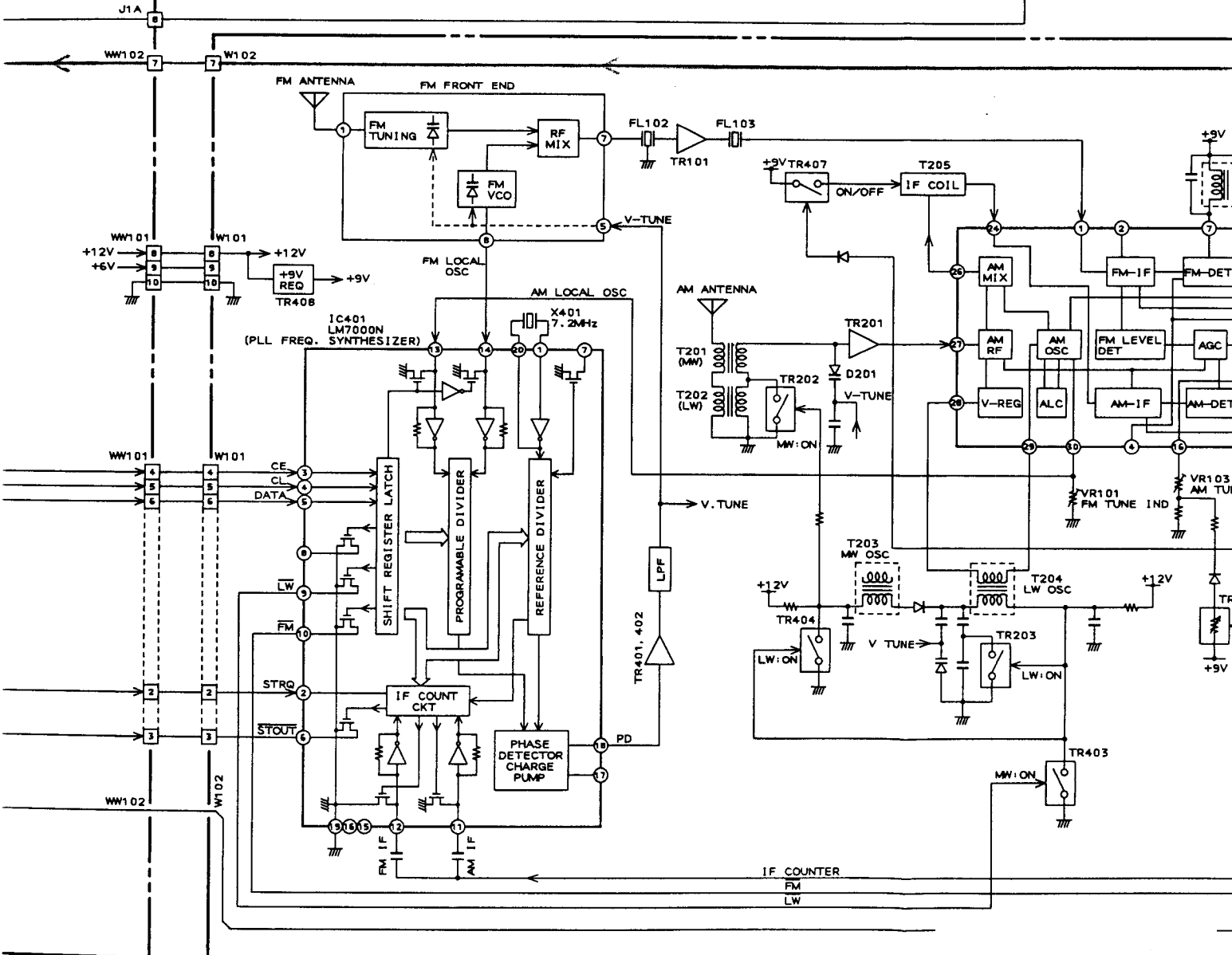
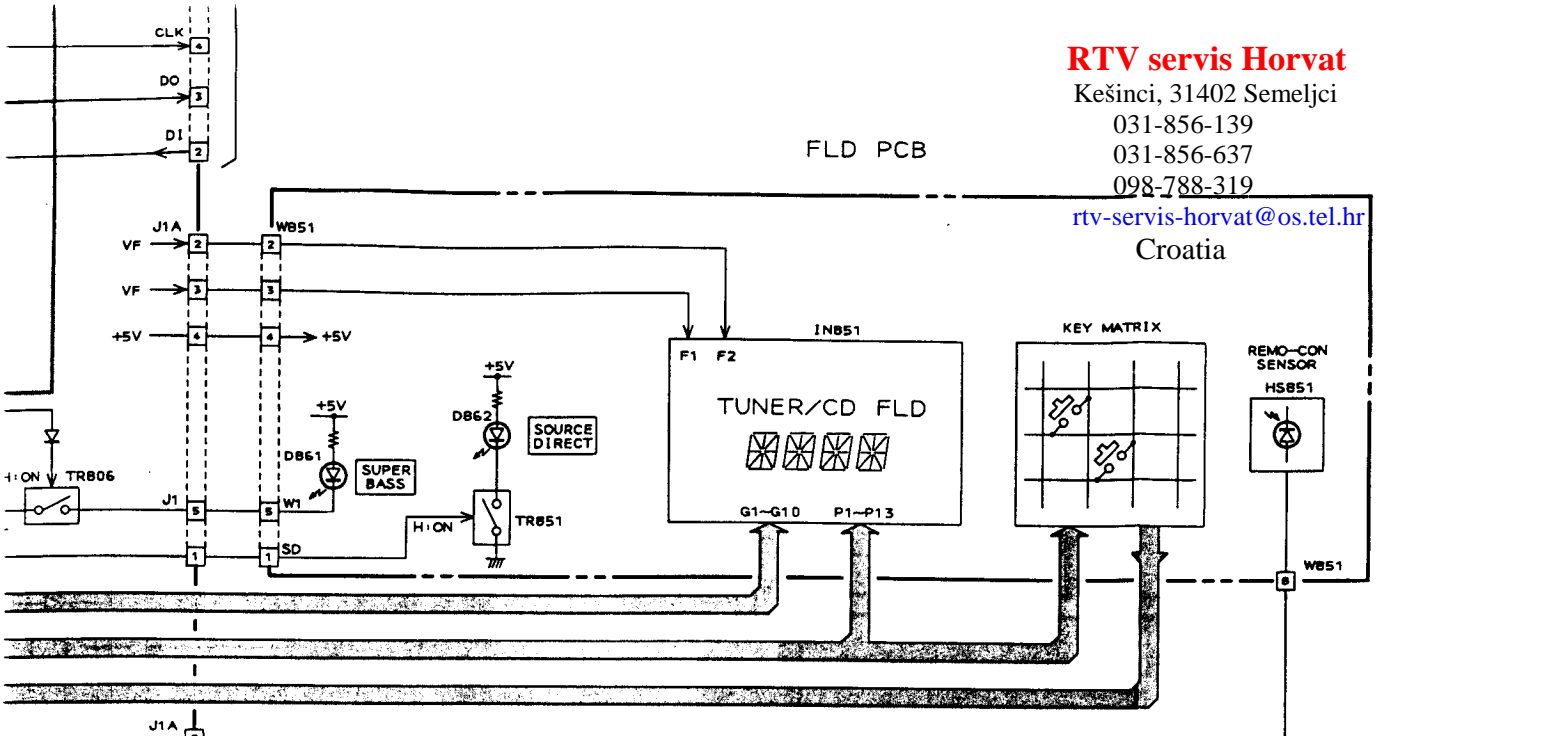

TUNER PCB

——— AUDIO SIGNAL LINE (L-CH)

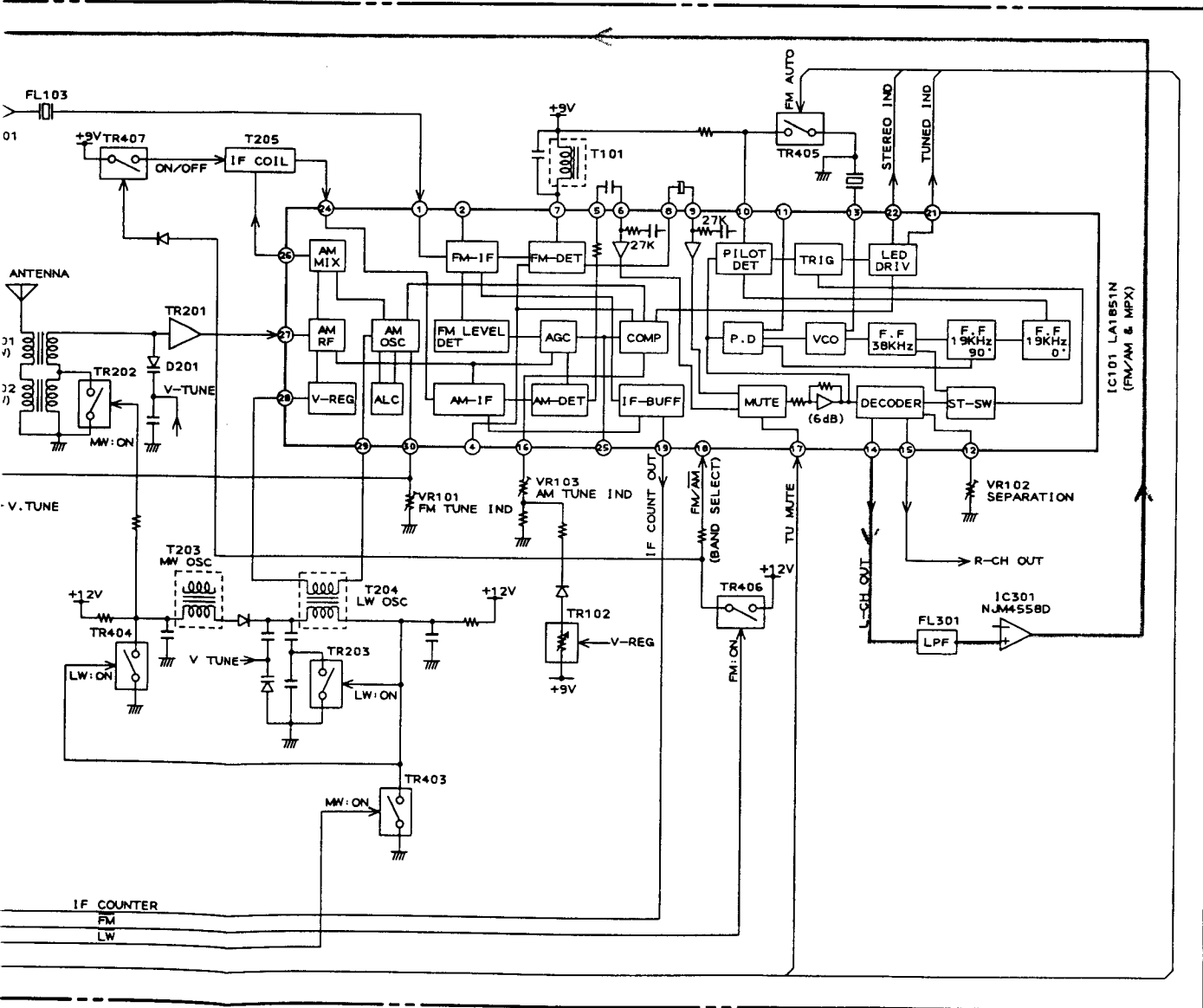
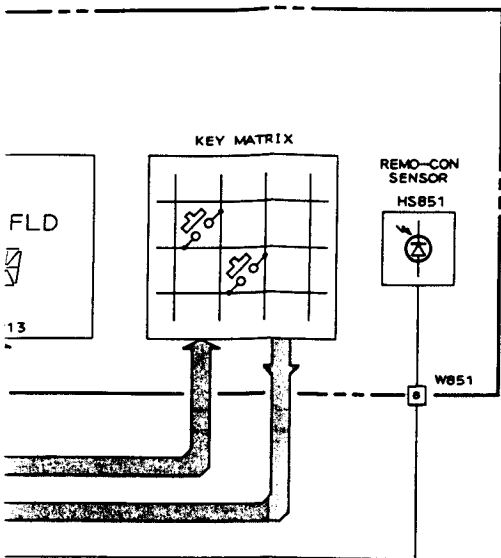

AUDIO SIGNAL LINE (L-CH)

TP-750  
BLOCK DIAGRAM  
No.5-1 A600951M

3  
4  
5  
6  
7  
8

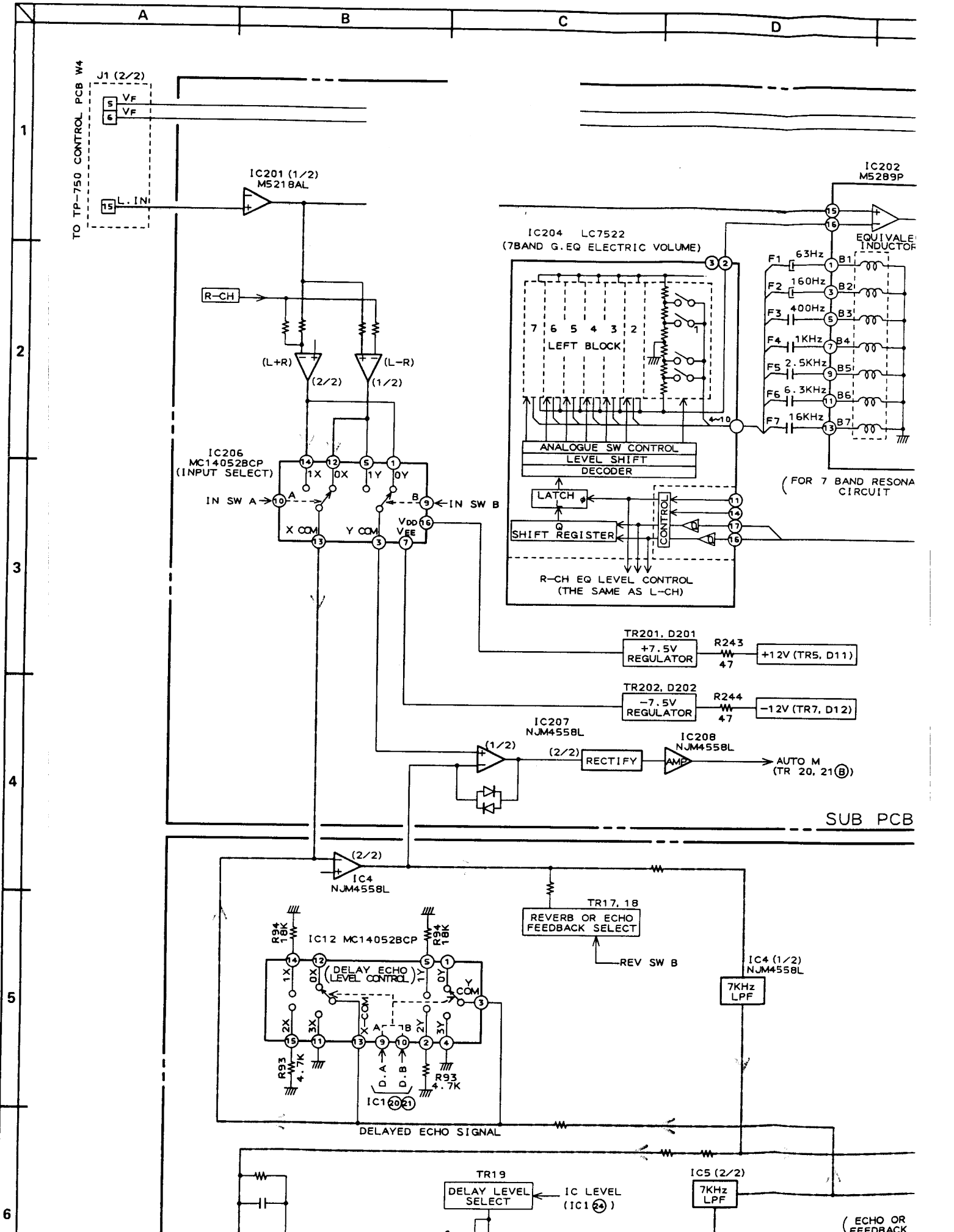

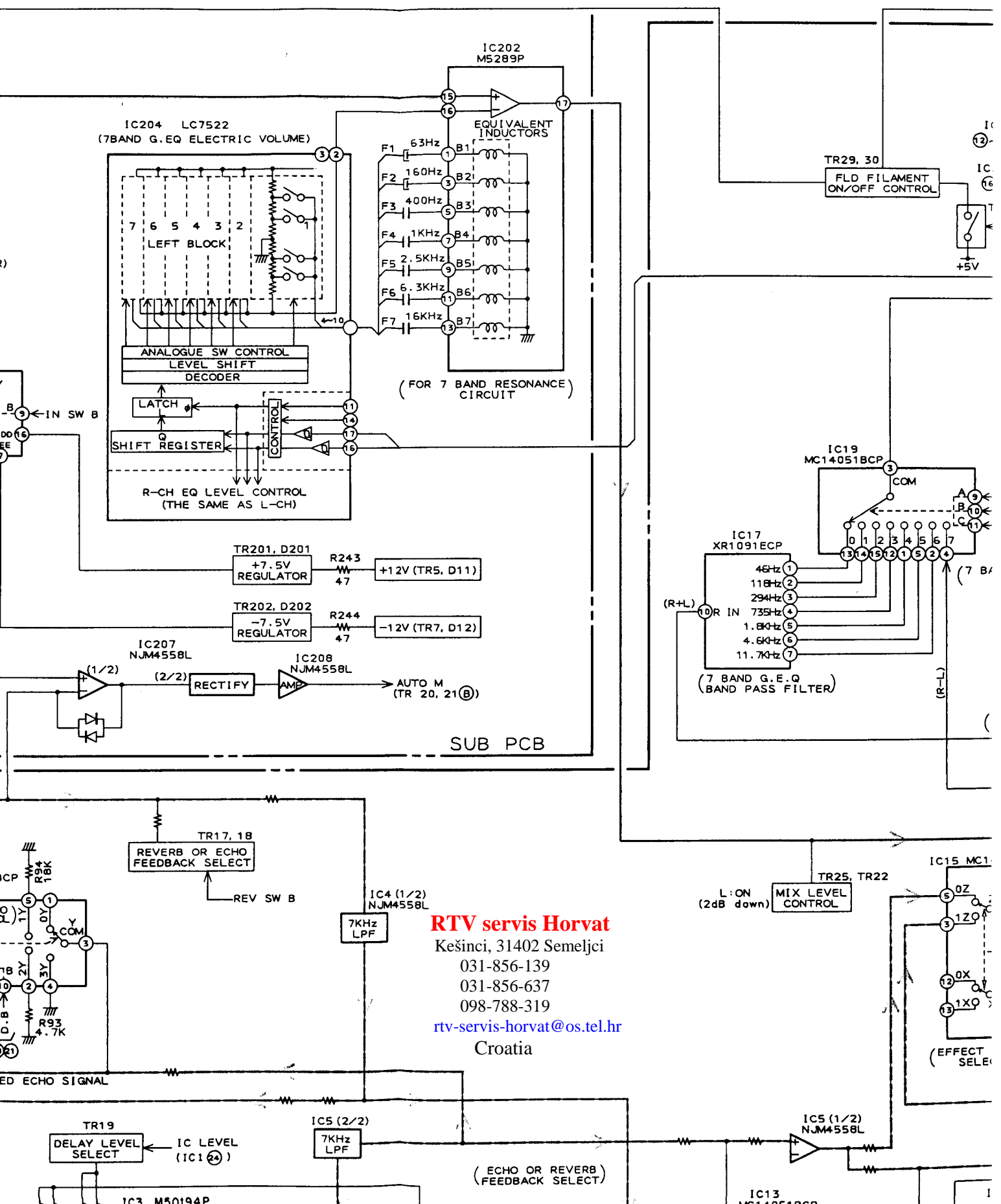

**RTV servis Horvat**

Kešinci, 31402 Semeljci

031-856-139

031-856-637

098-788-319

[rtv-servis-horvat@os.tel.hr](mailto:rtv-servis-horvat@os.tel.hr)

Croatia

FRONT

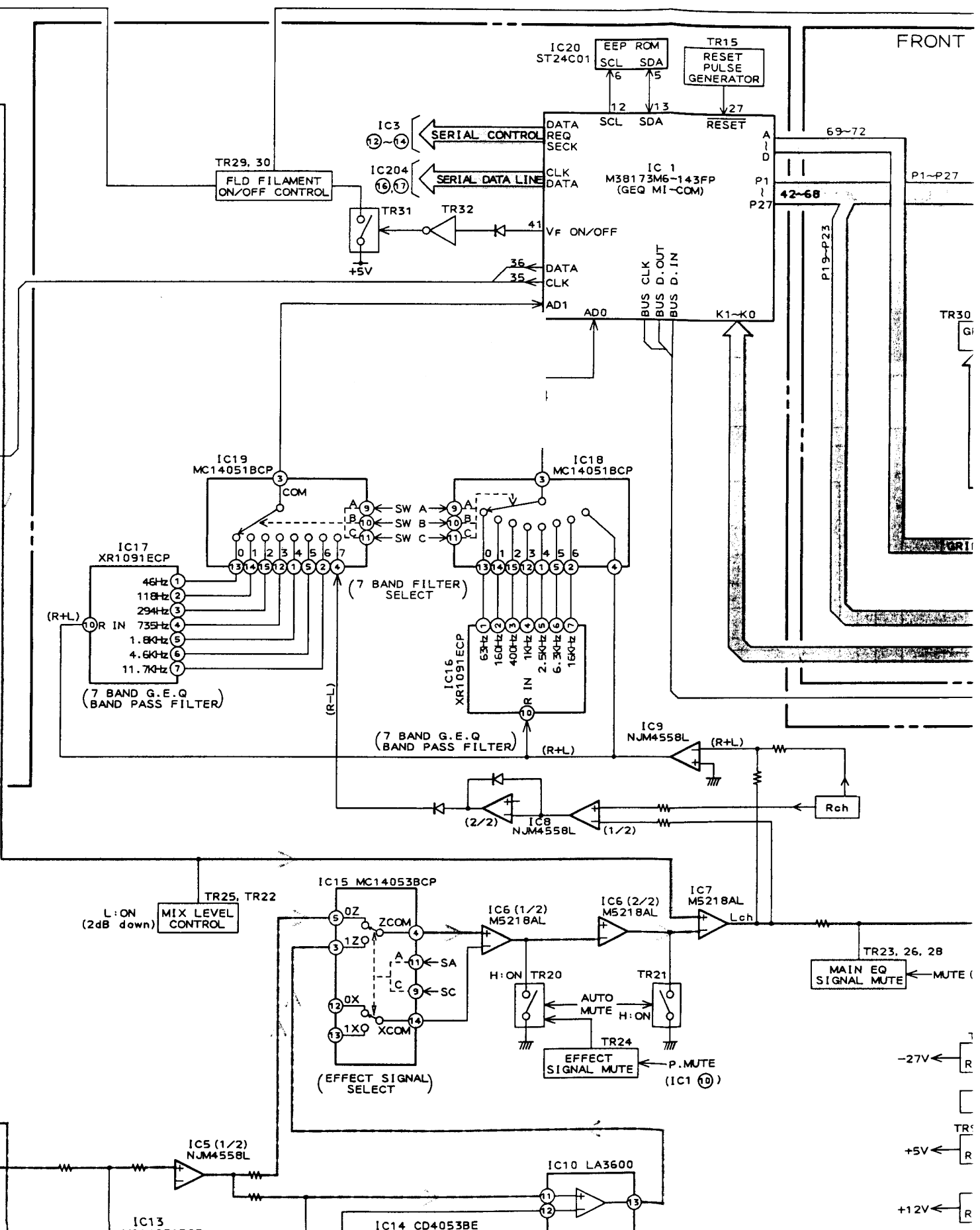

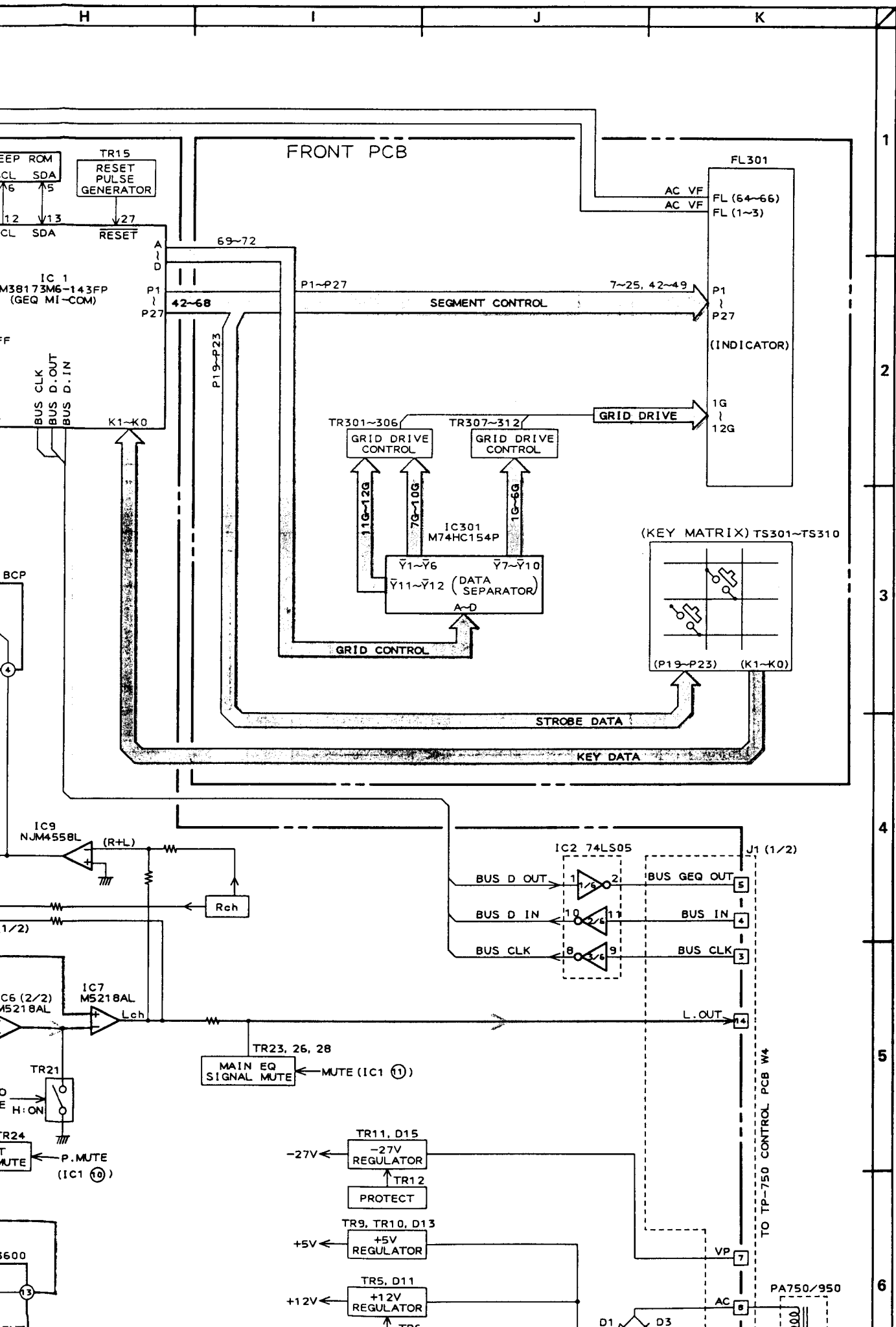

1

2

3

4

5

6

3

4

5

6

7

8

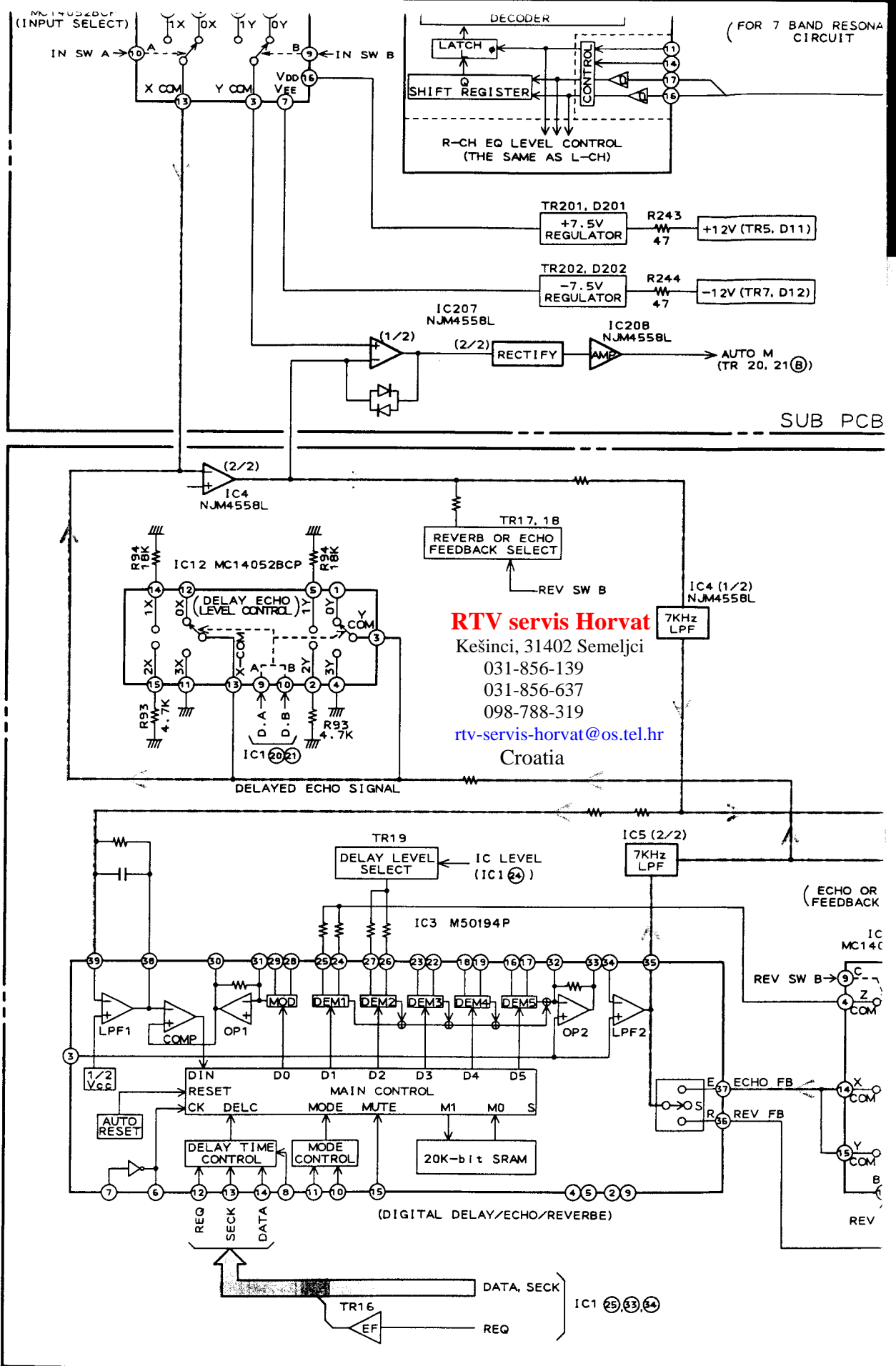



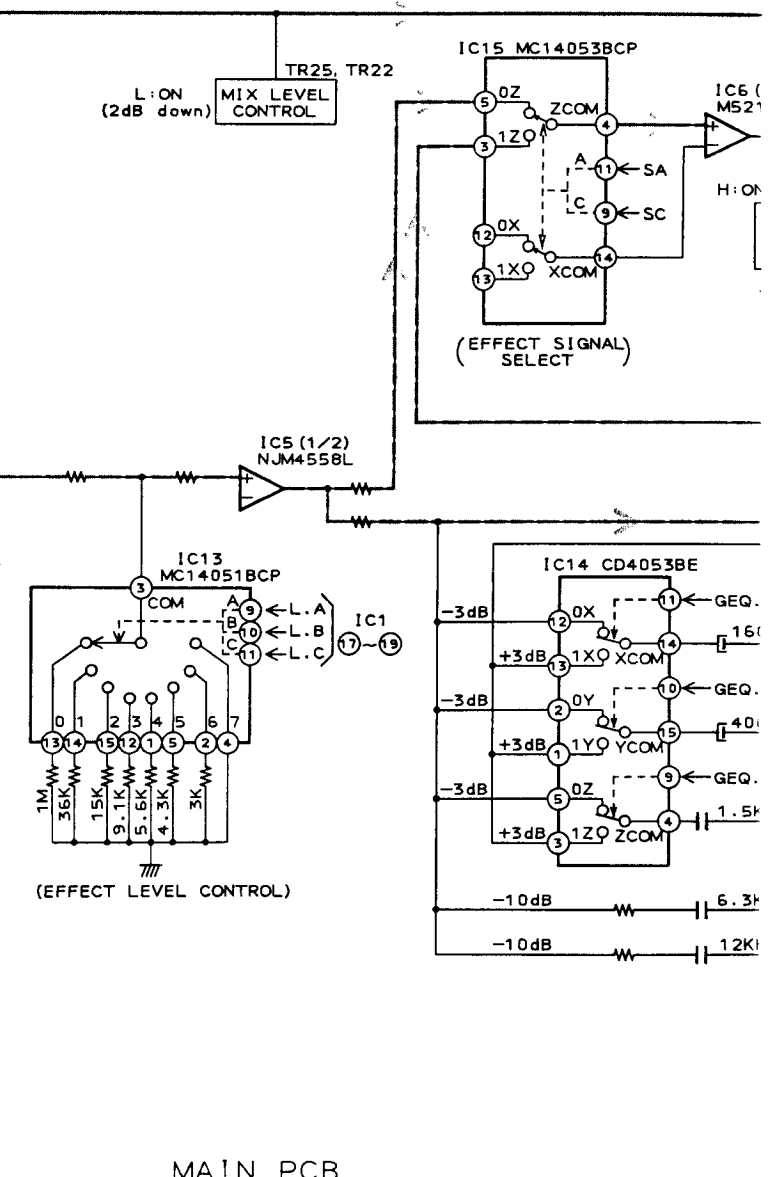
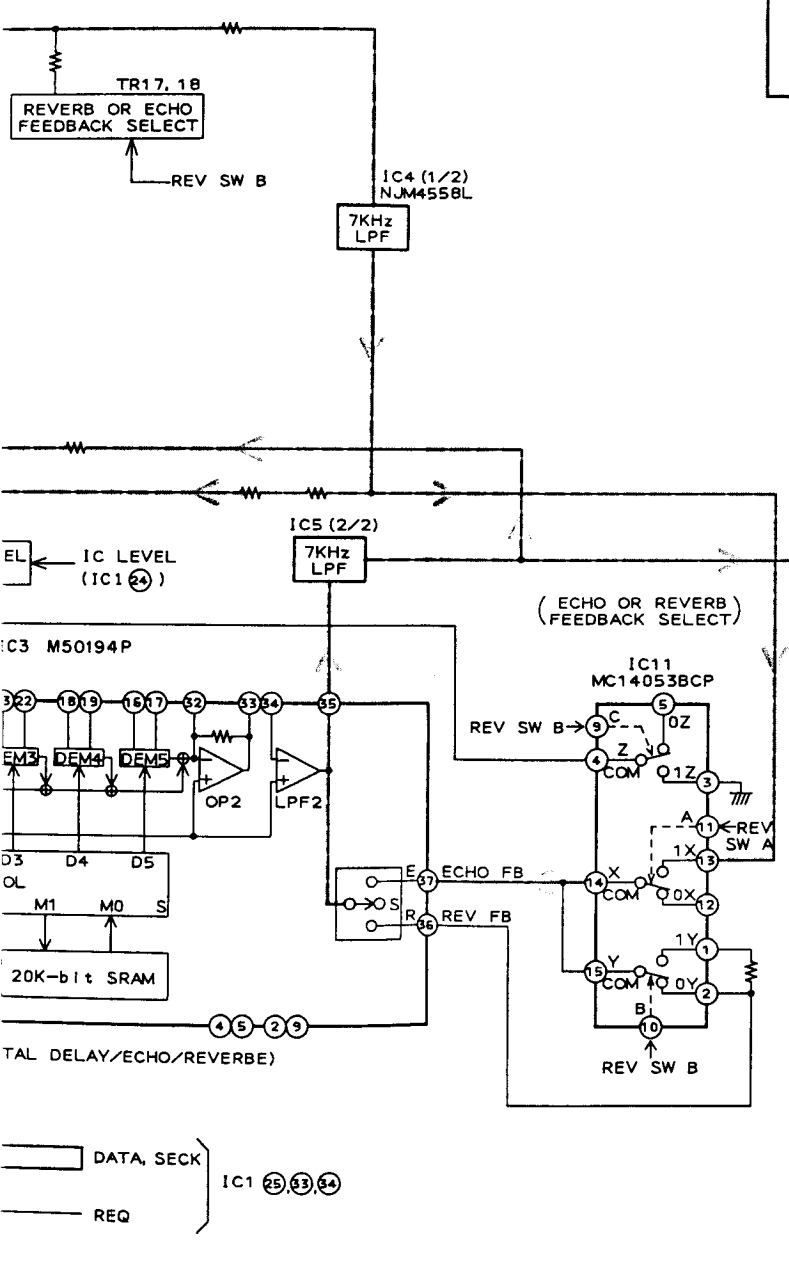
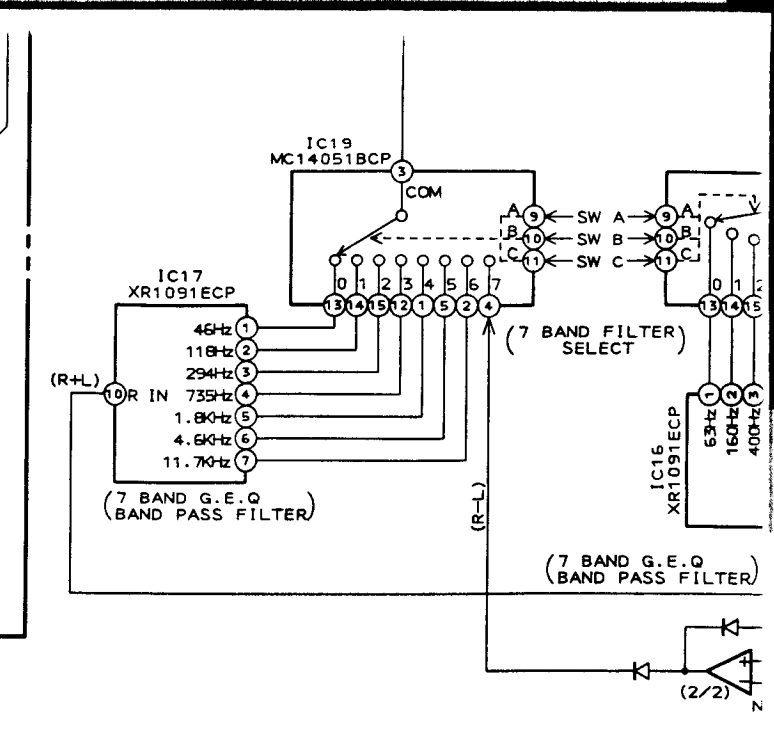
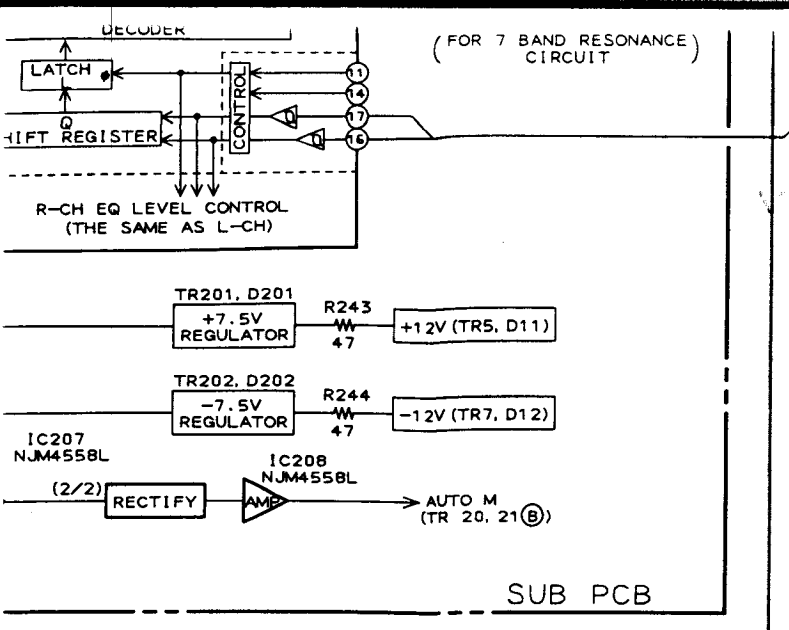

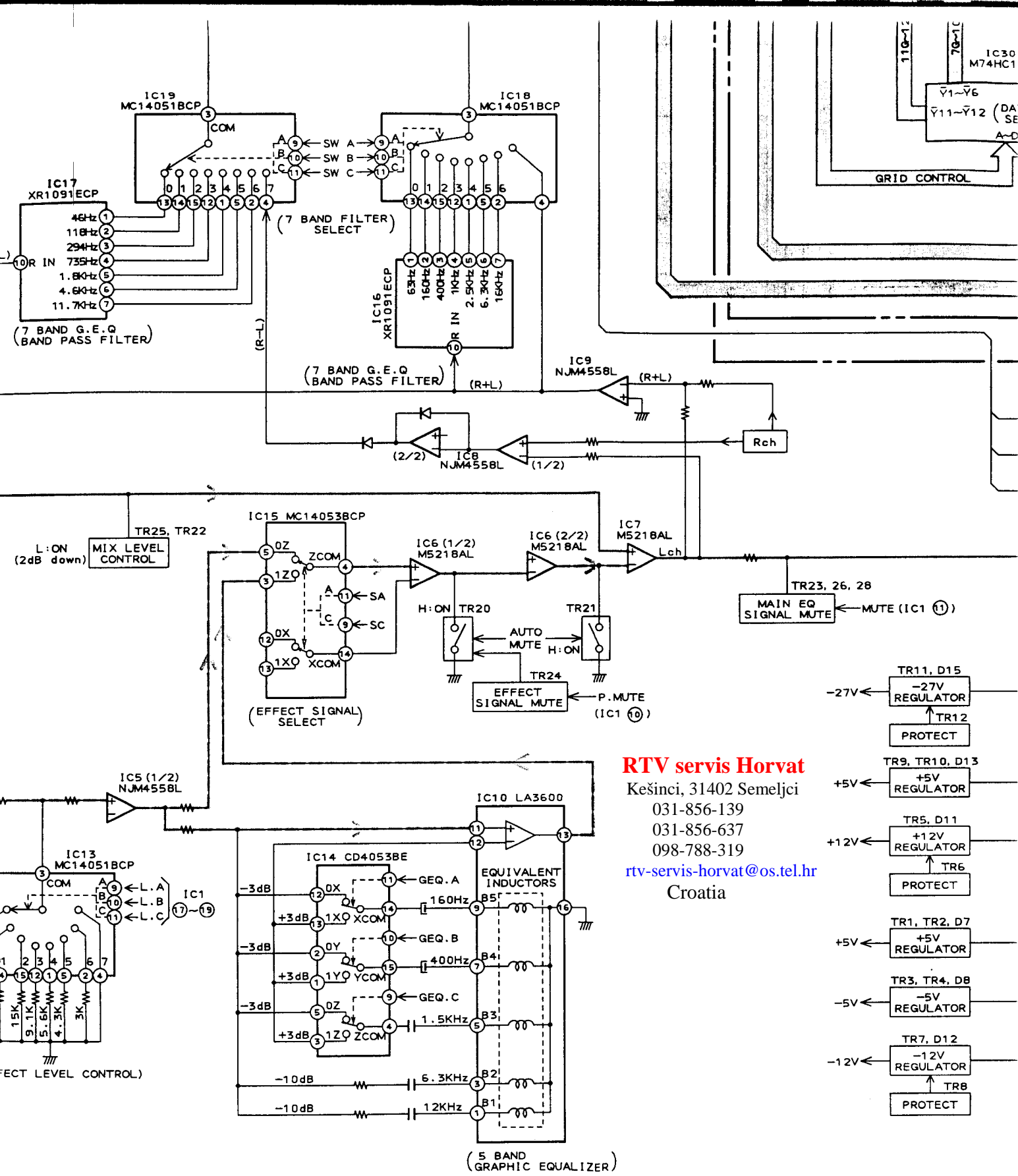

MAIN PCB

**RTV servis Horvat**

Kešinci, 31402 Semeljci

031-856-139

031-856-637

098-788-319

[rtv-servis-horvat@os.tel.hr](mailto:rtv-servis-horvat@os.tel.hr)

Croatia

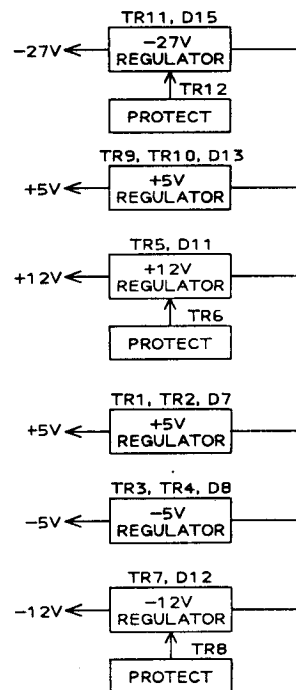

————— AUDIO SIGNAL LINE (Lch)  
 - - - - - EFFECT SIGNAL LINE

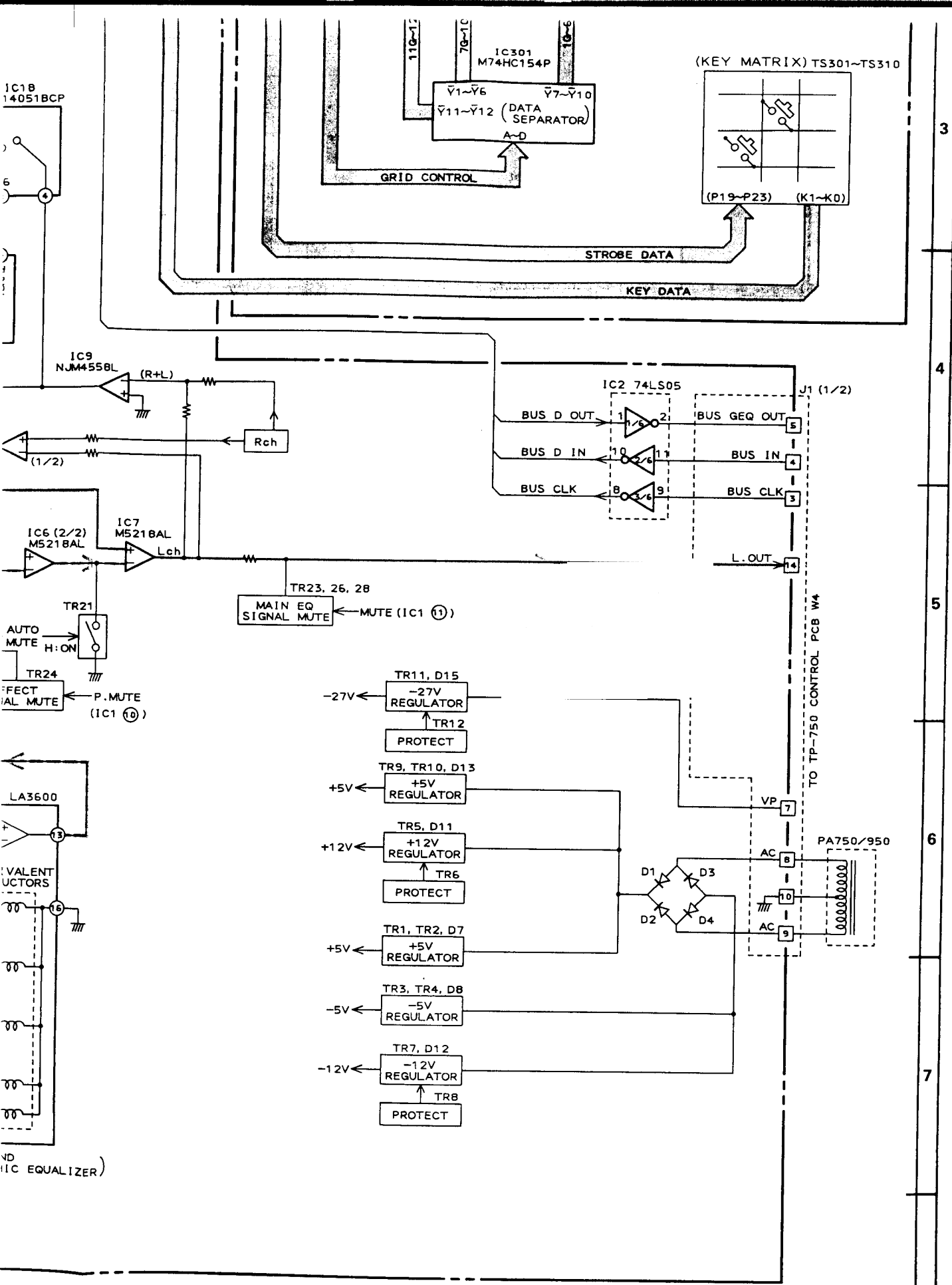

EA-750  
 BLOCK DIAGRAM  
 No.5-2 D301651M

3  
 4  
 5  
 6  
 7  
 8

1

2

3

4

5

6

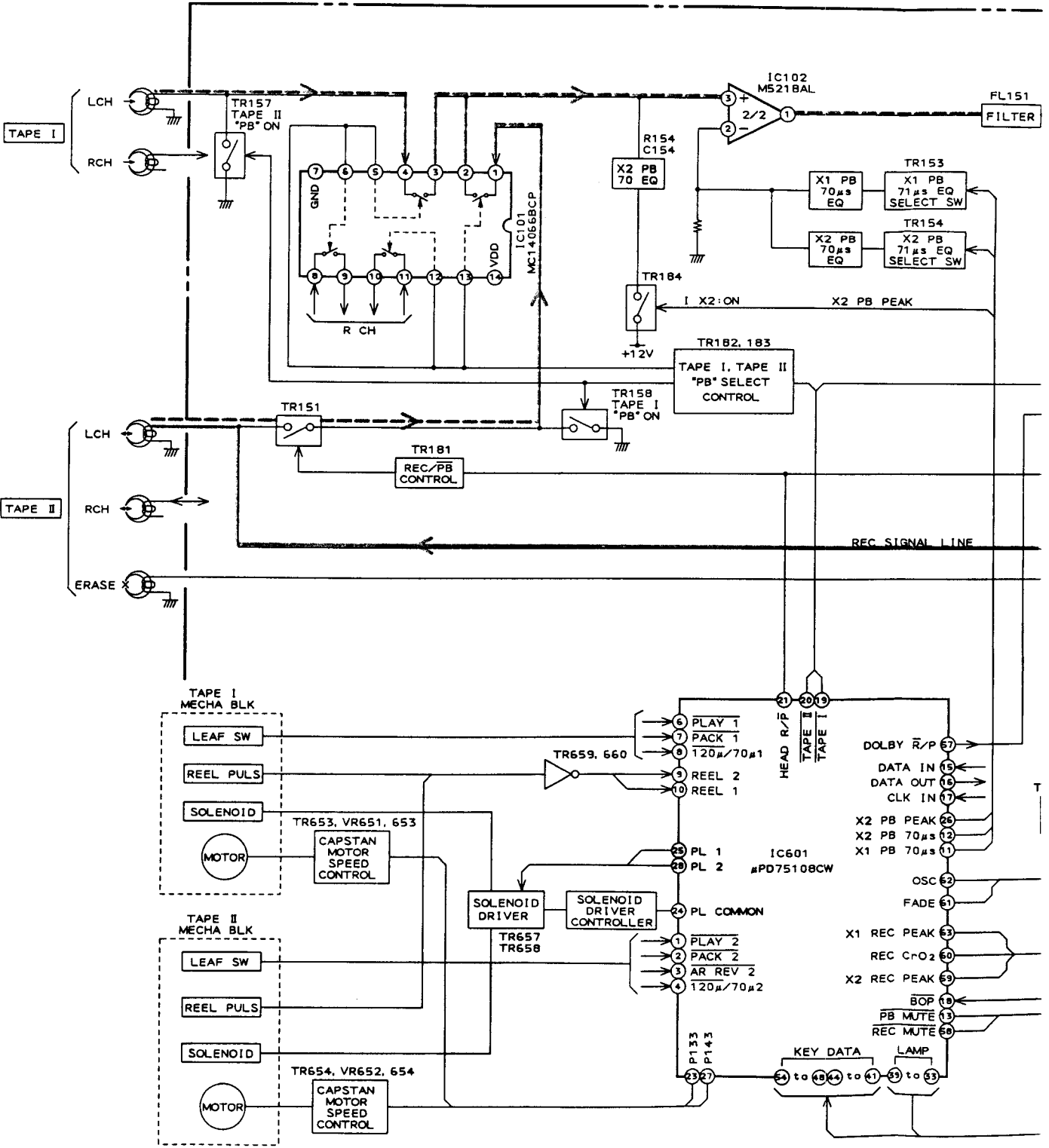

TAPE I  
LCH  
RCH

TAPE II  
LCH  
RCH  
ERASE

TAPE I  
MECHA BLK  
LEAF SW  
REEL PULS  
SOLENOID  
MOTOR  
CAPSTAN MOTOR  
SPEED CONTROL

TAPE II  
MECHA BLK  
LEAF SW  
REEL PULS  
SOLENOID  
MOTOR  
CAPSTAN MOTOR  
SPEED CONTROL

PLAY 1  
PACK 1  
120μ/70μ1  
REEL 2  
REEL 1  
PL 1  
PL 2  
PL COMMON  
PLAY 2  
PACK 2  
AR REV 2  
120μ/70μ2

HEAD R/P  
TAPE I  
TAPE II  
DOLBY R/P  
DATA IN  
DATA OUT  
CLK IN  
X2 PB PEAK  
X2 PB 70μs  
X1 PB 70μs  
OSC  
FADE  
X1 REC PEAK  
REC CrO2  
X2 REC PEAK  
BOP  
PB MUTE  
REC MUTE

KEY DATA  
LAMP

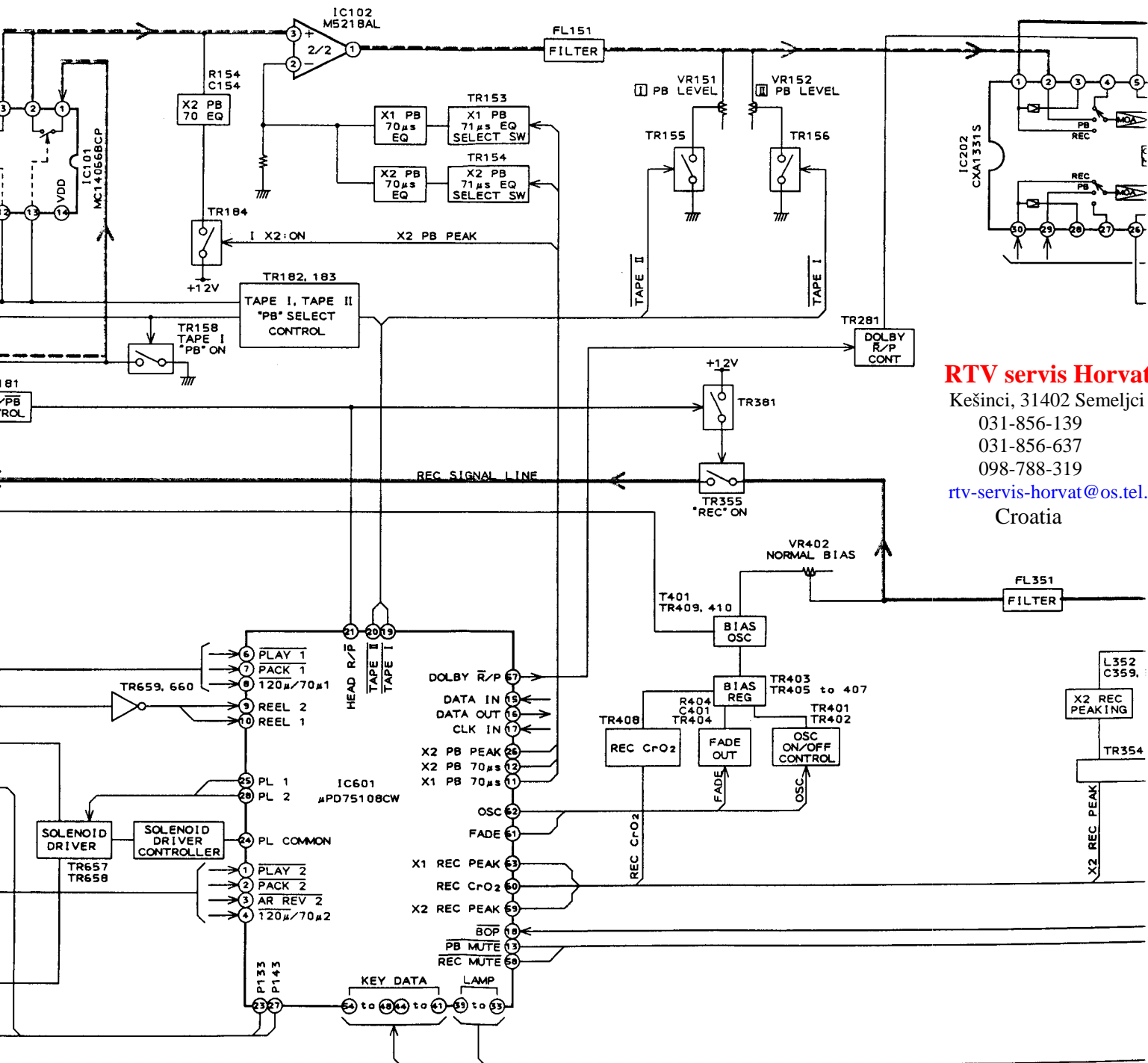

**RTV servis Horvat**  
 Kešinci, 31402 Semeljci  
 031-856-139  
 031-856-637  
 098-788-319  
[rtv-servis-horvat@os.tel.hr](mailto:rtv-servis-horvat@os.tel.hr)  
 Croatia

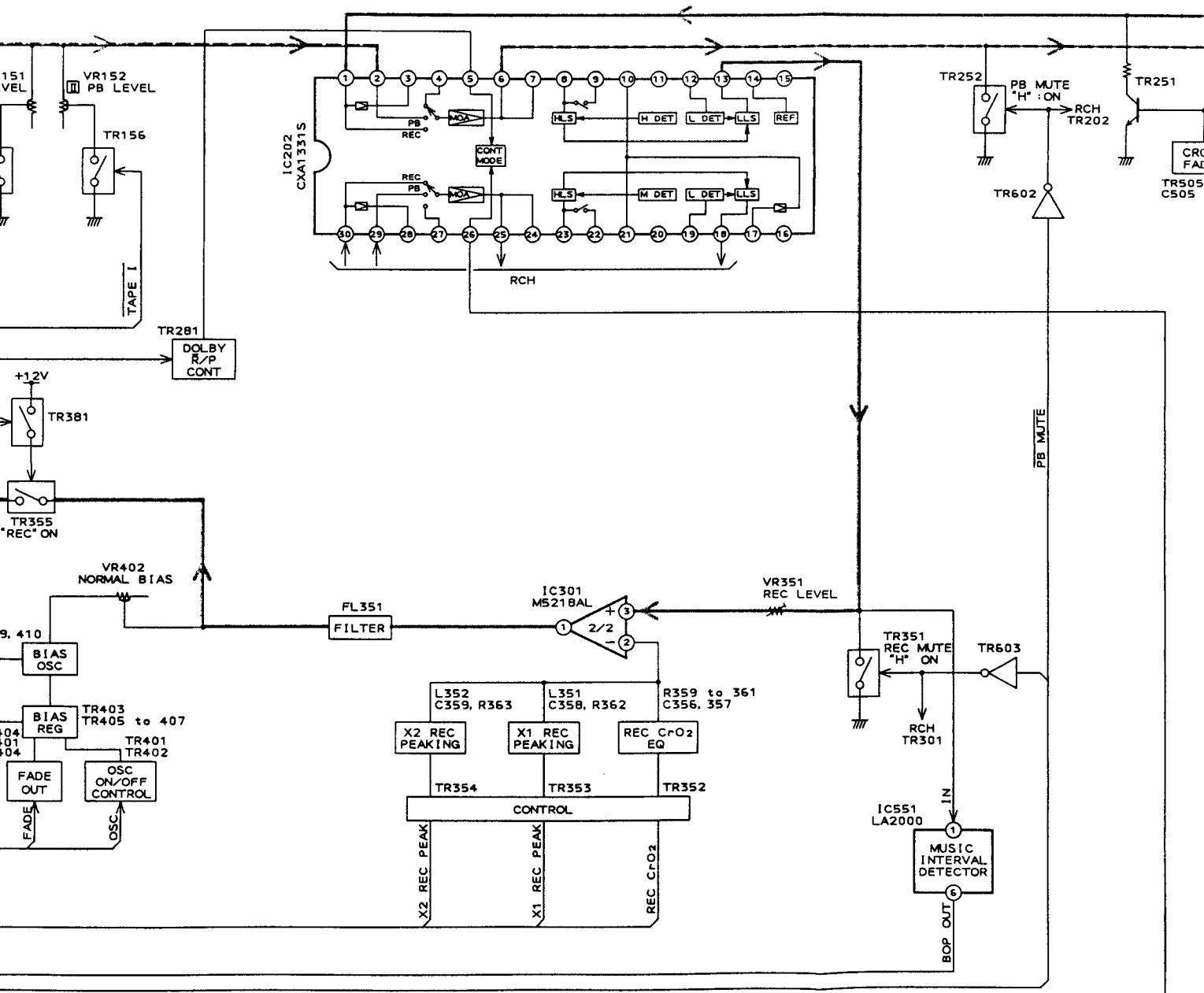

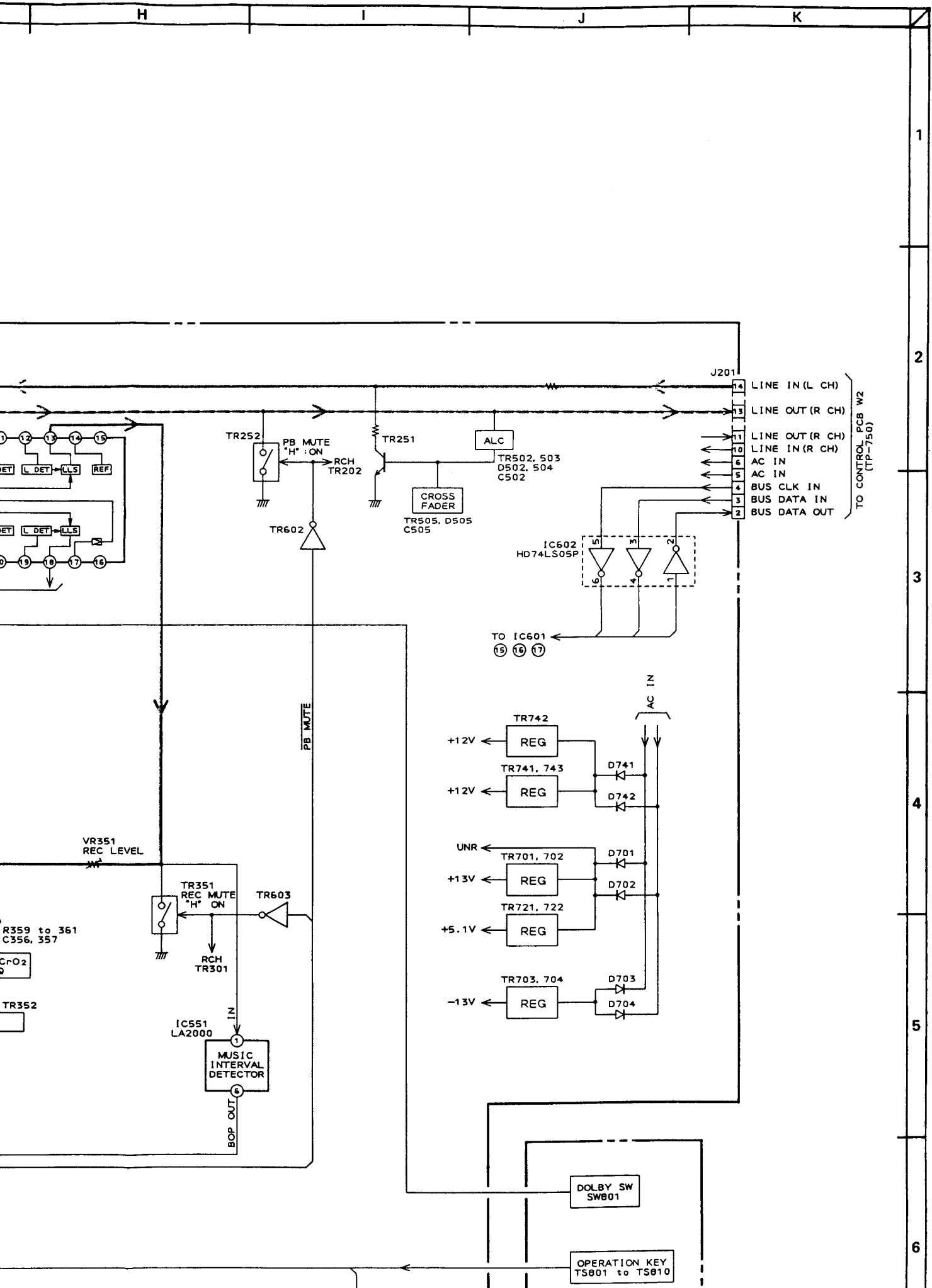

1  
2  
3  
4  
5  
6

3  
4  
5  
6  
7  
8

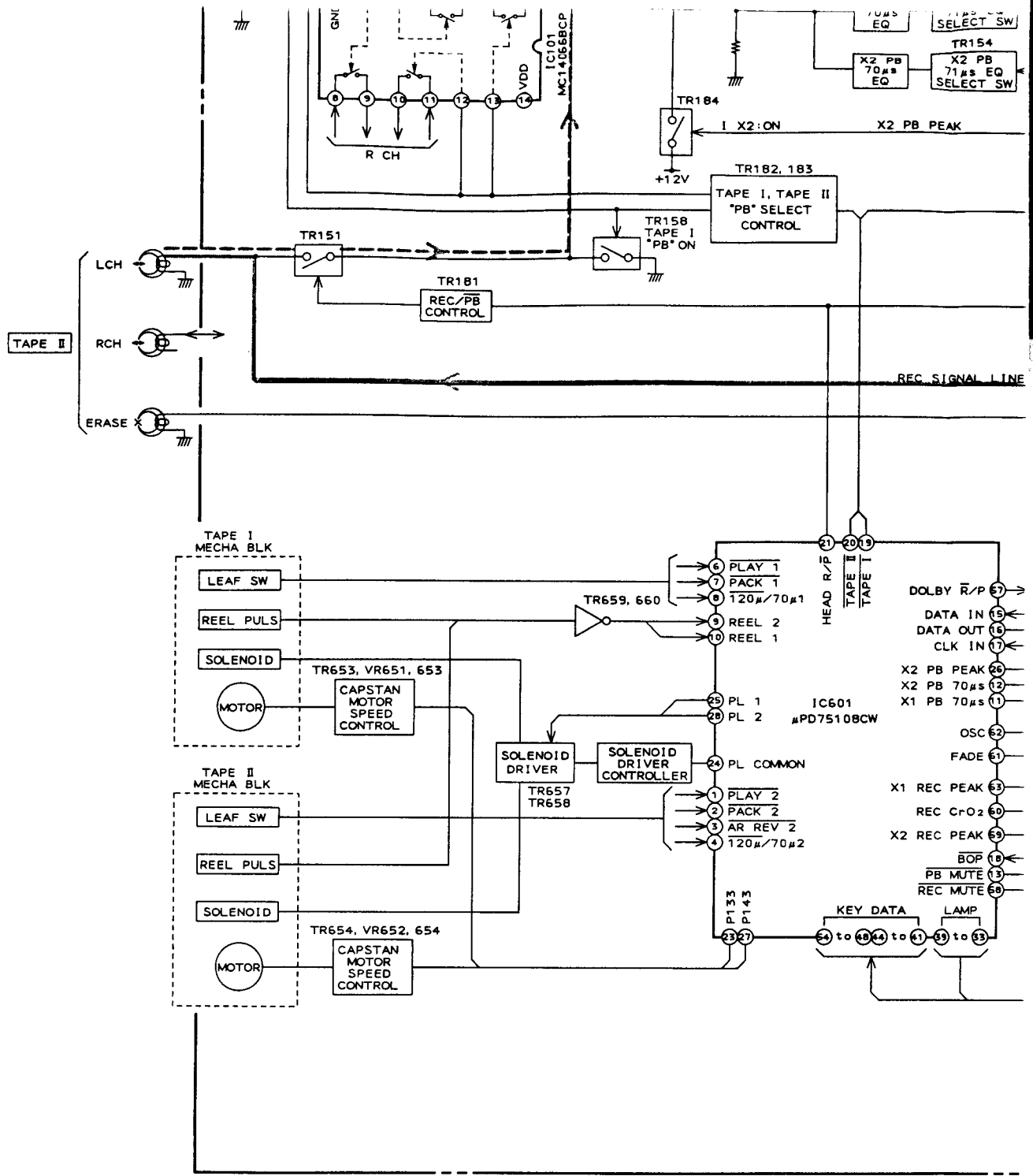



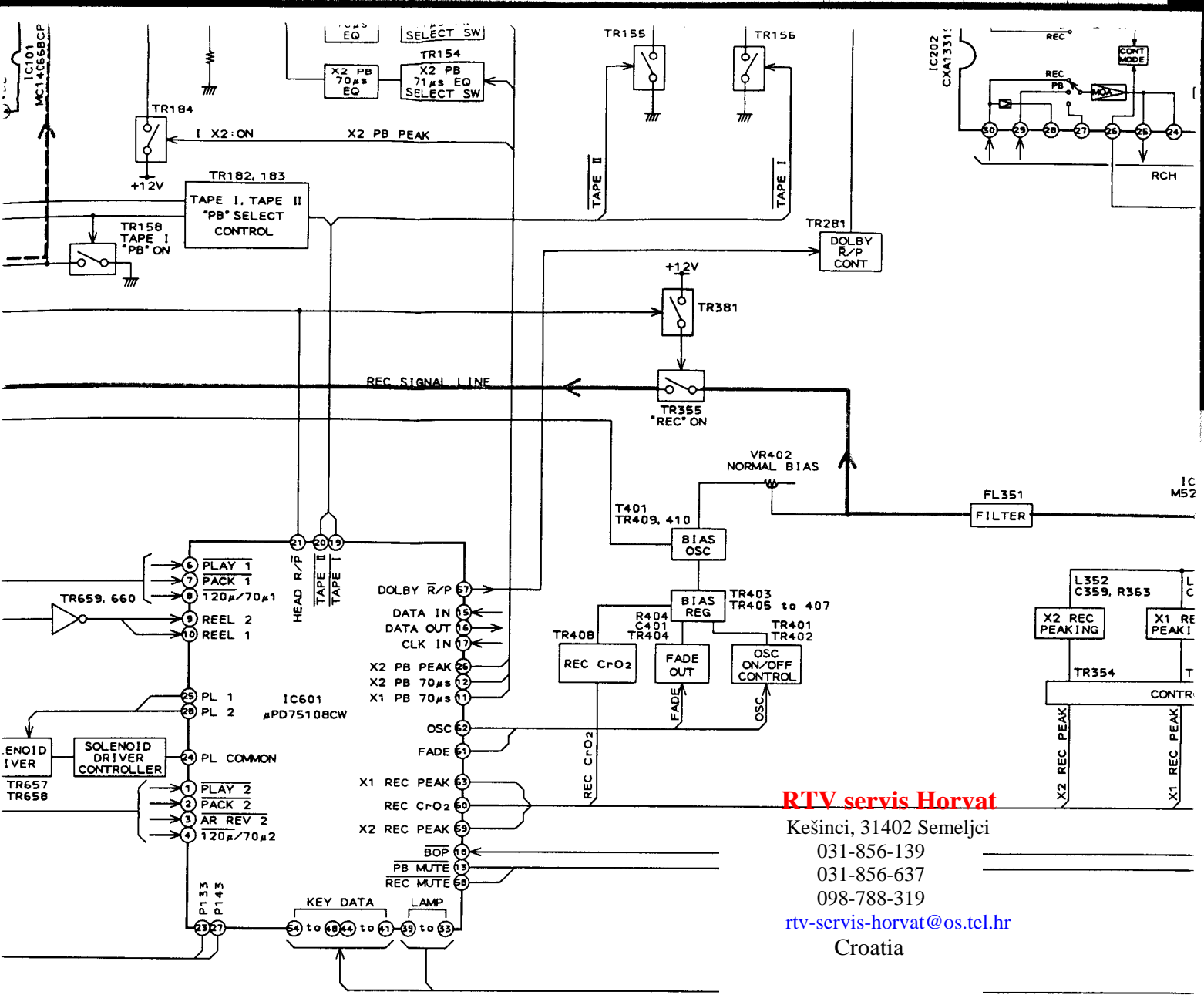

**RTV servis Horvat**

Kešinci, 31402 Semeljci

031-856-139

031-856-637

098-788-319

[rtv-servis-horvat@os.tel.hr](mailto:rtv-servis-horvat@os.tel.hr)

Croatia

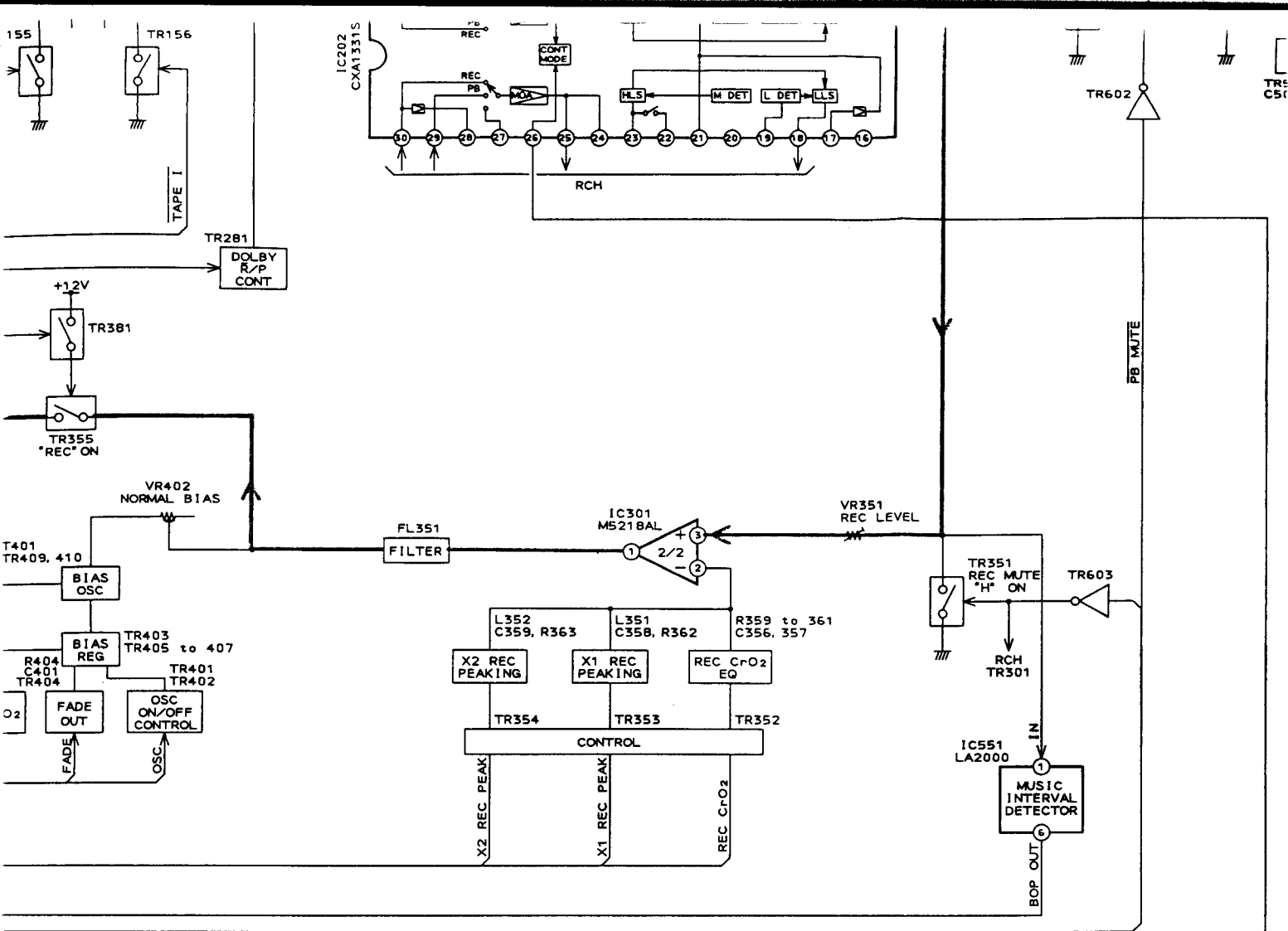

DECK PCB

----- : PB SIGNAL LINE  
 \_\_\_\_\_ : REC SIGNAL LINE

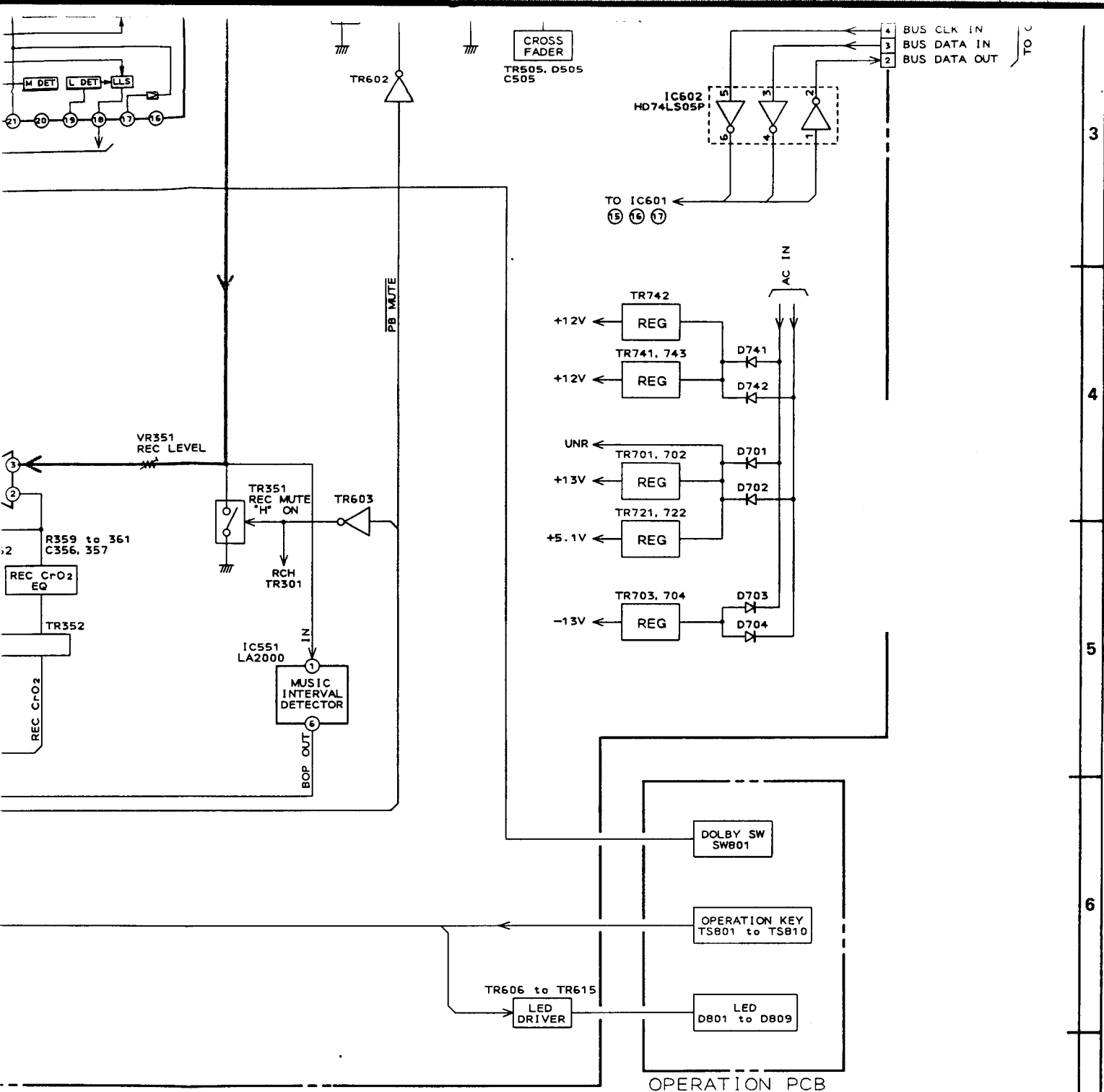

- - - - - : PB SIGNAL LINE  
 ————— : REC SIGNAL LINE

HX-750  
 DECK & OPERATION  
 BLOCK DIAGRAM  
 No. 5-3 T213451M  
 A1

3  
4  
5  
6  
7  
8

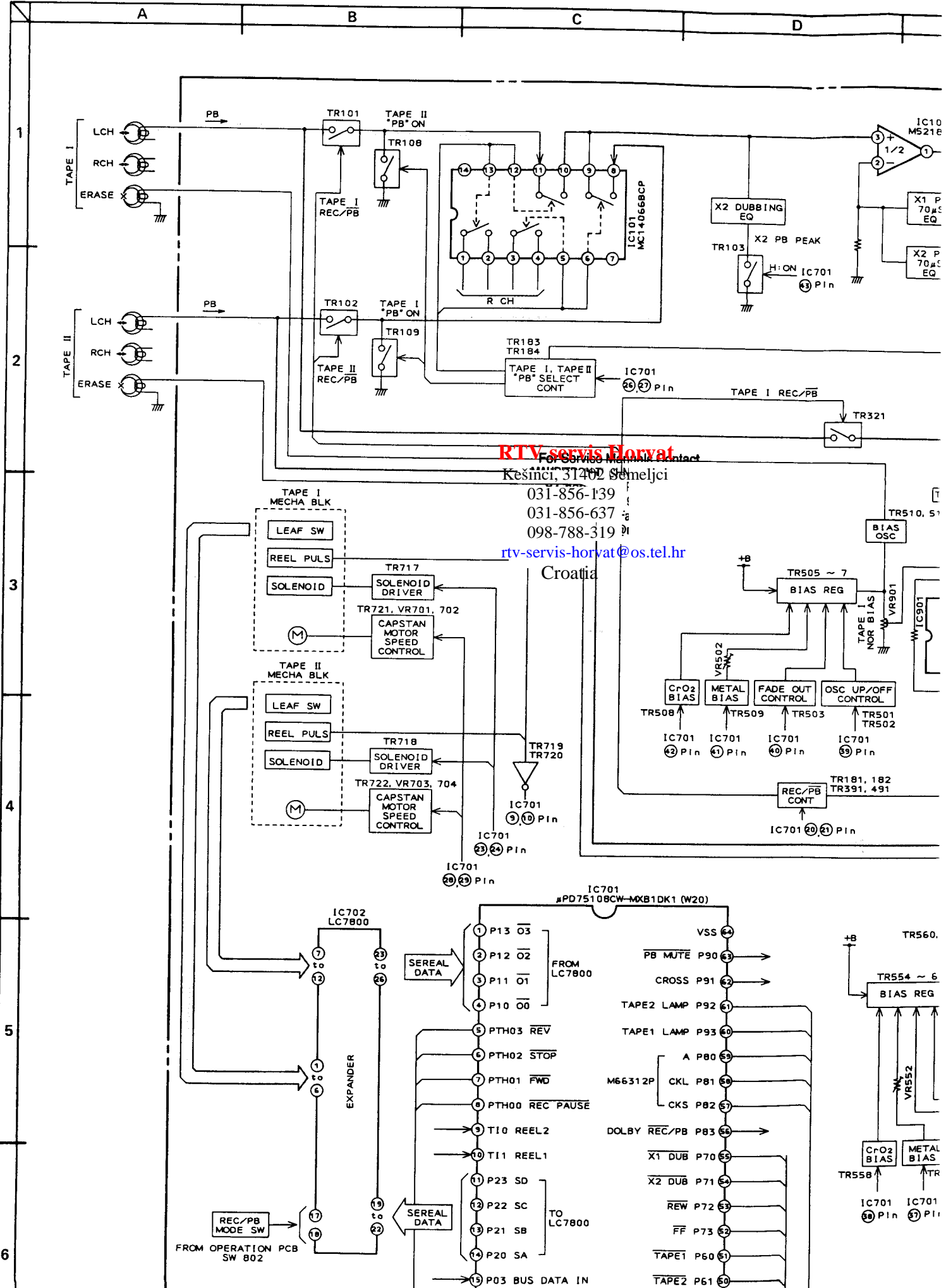

RTV servis Horvat

Kešinci, 31402 Šemeljci

031-856-139

031-856-637

098-788-319

rtv-servis-horvat@os.tel.hr

Croatia

1  
2  
3  
4  
5  
6

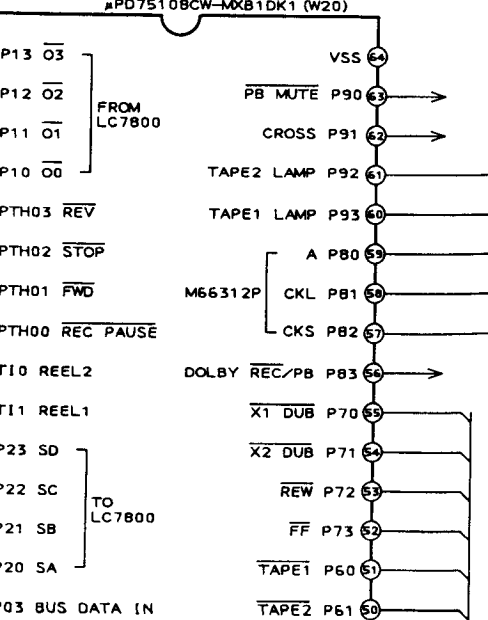
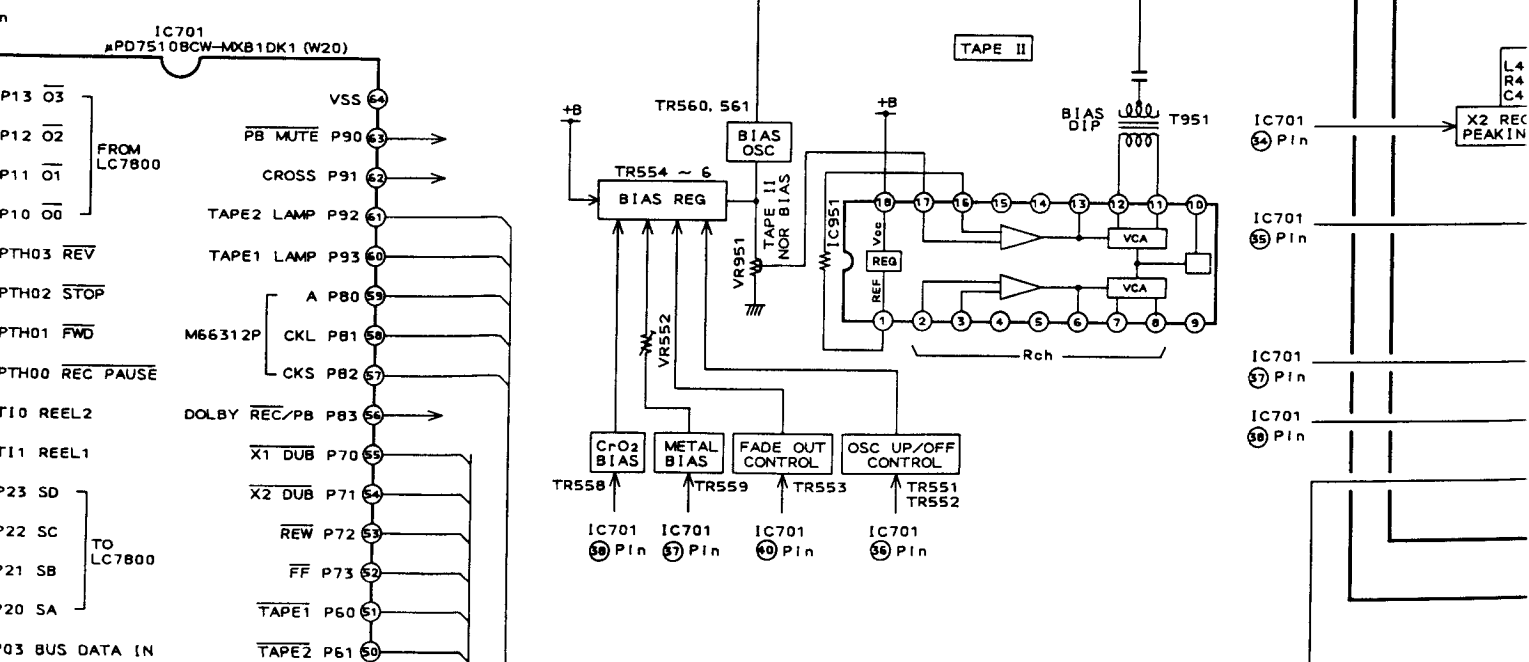
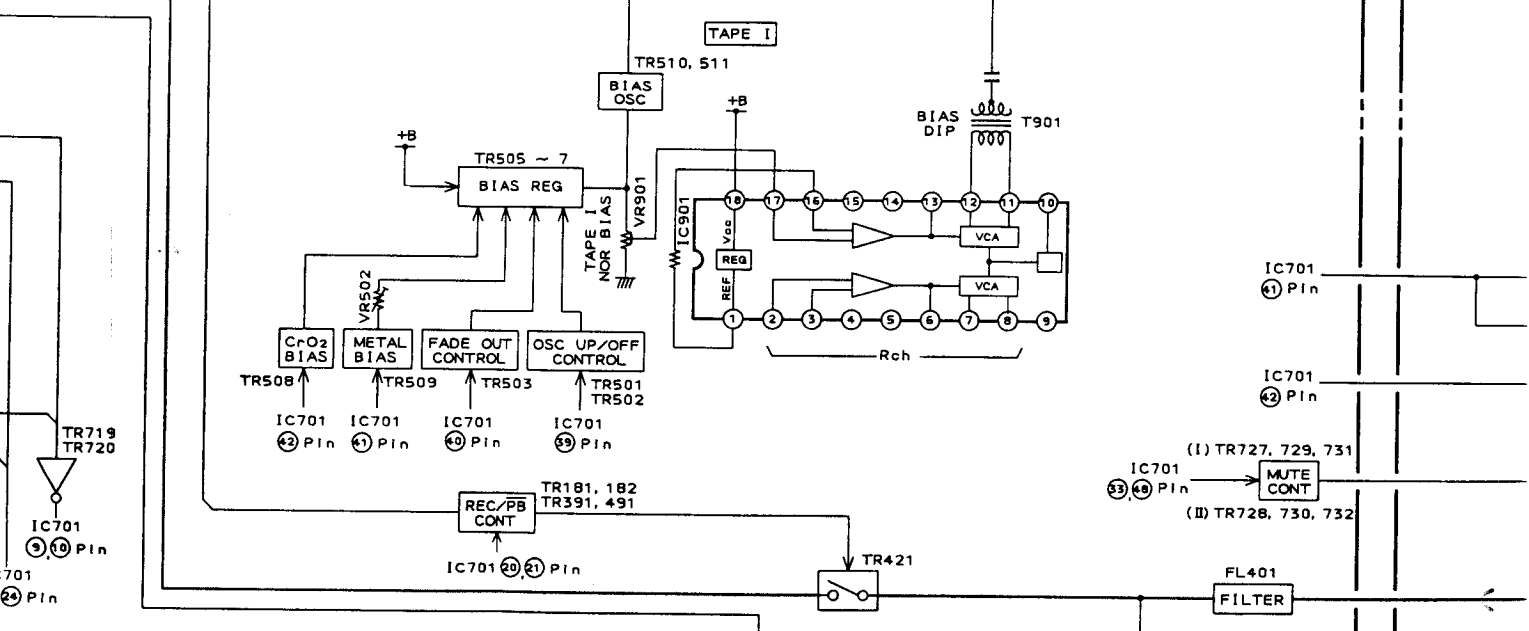
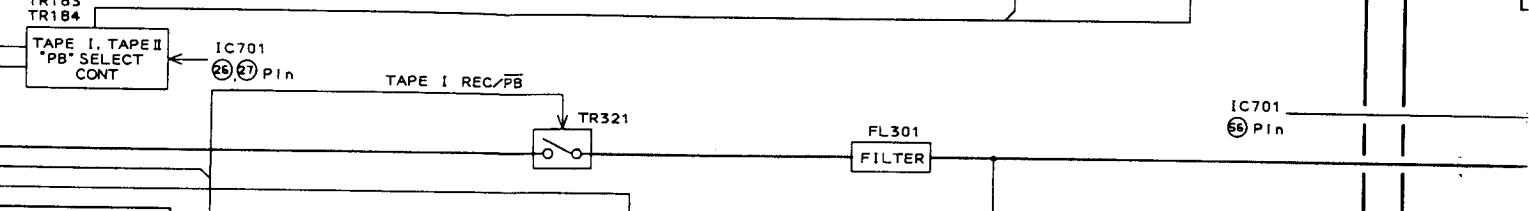
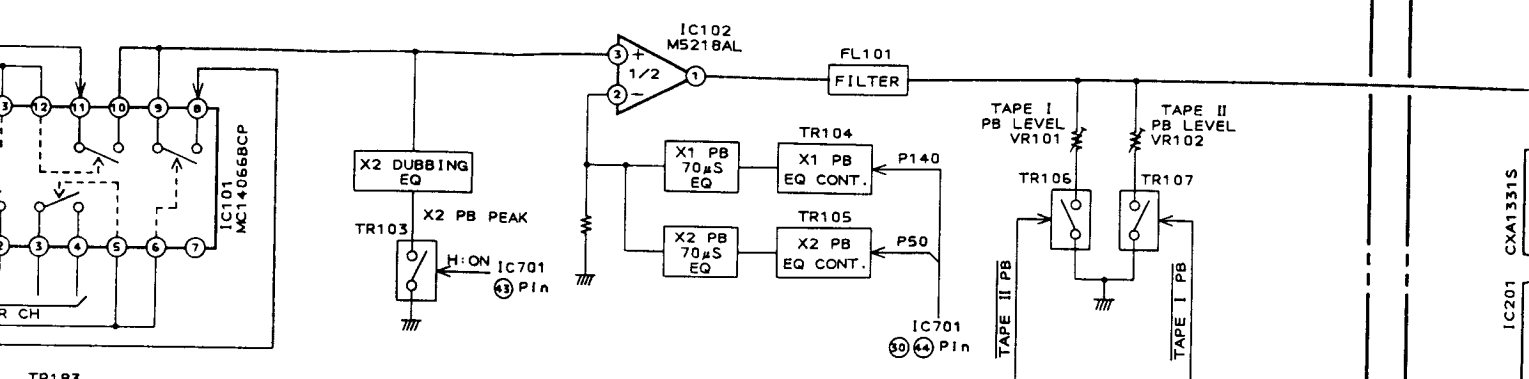

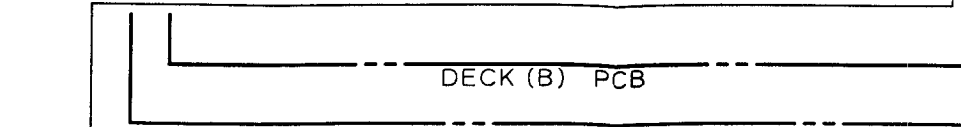
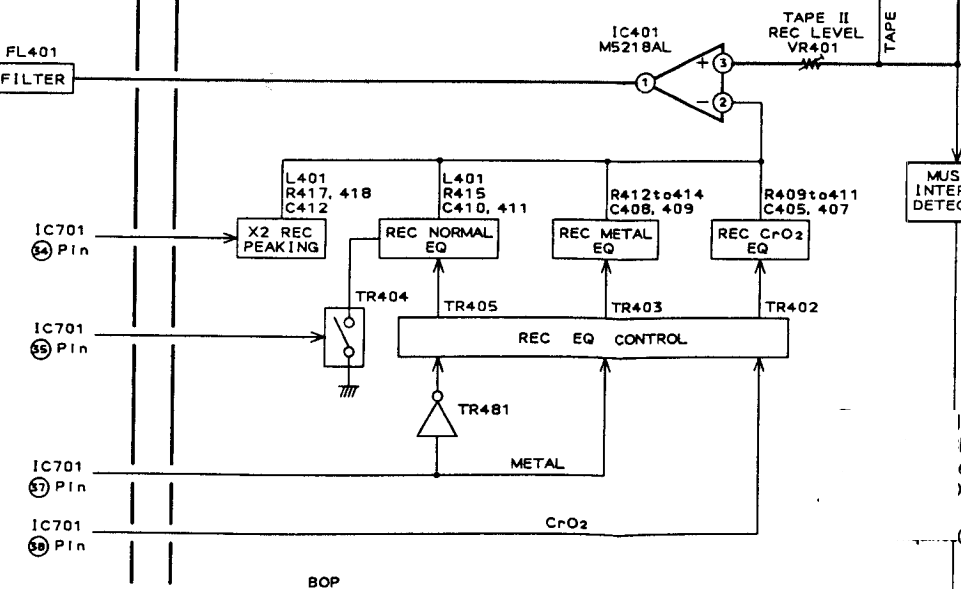
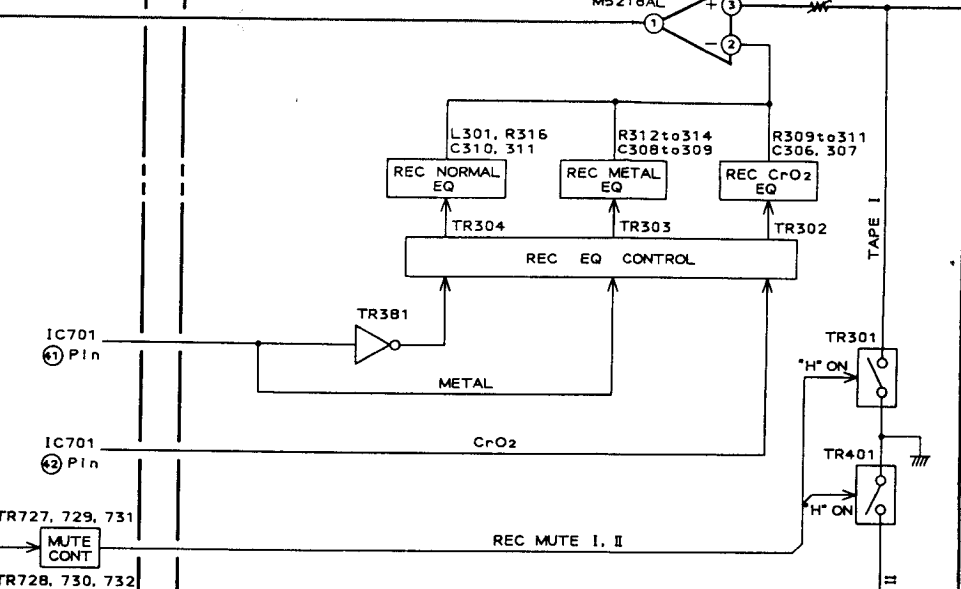
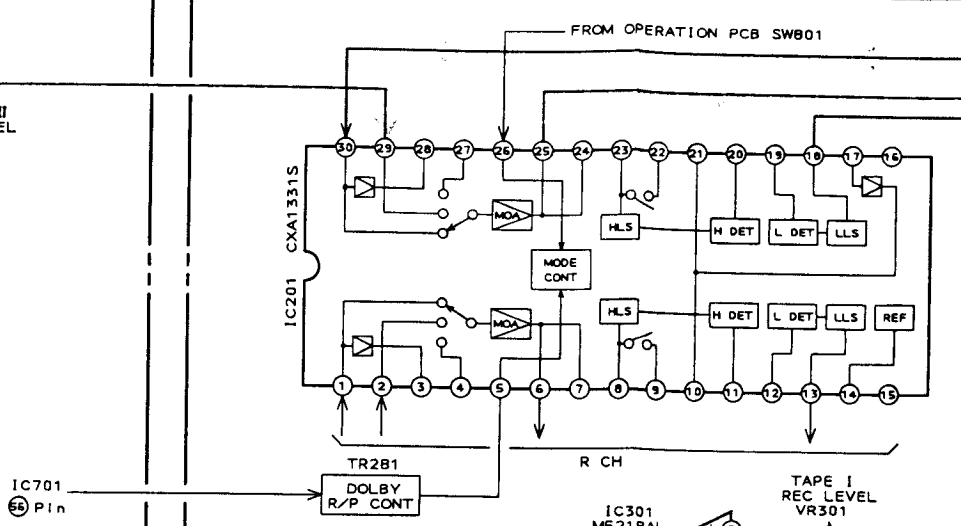
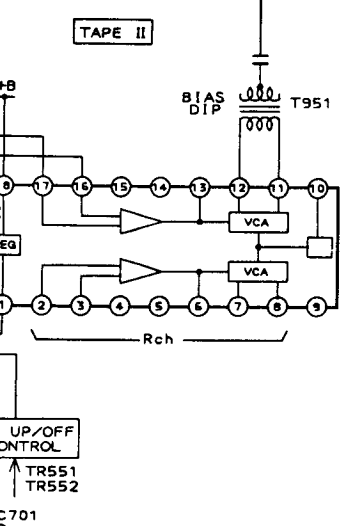
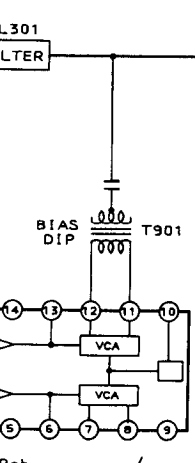
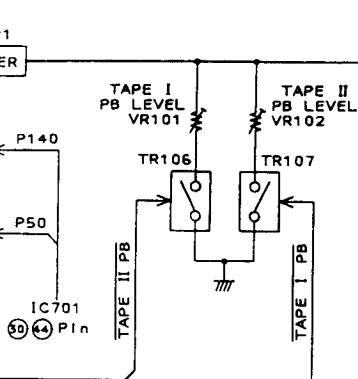

TR:  
MECH  
MECH  
SY  
PRE  
BIAS  
PRE

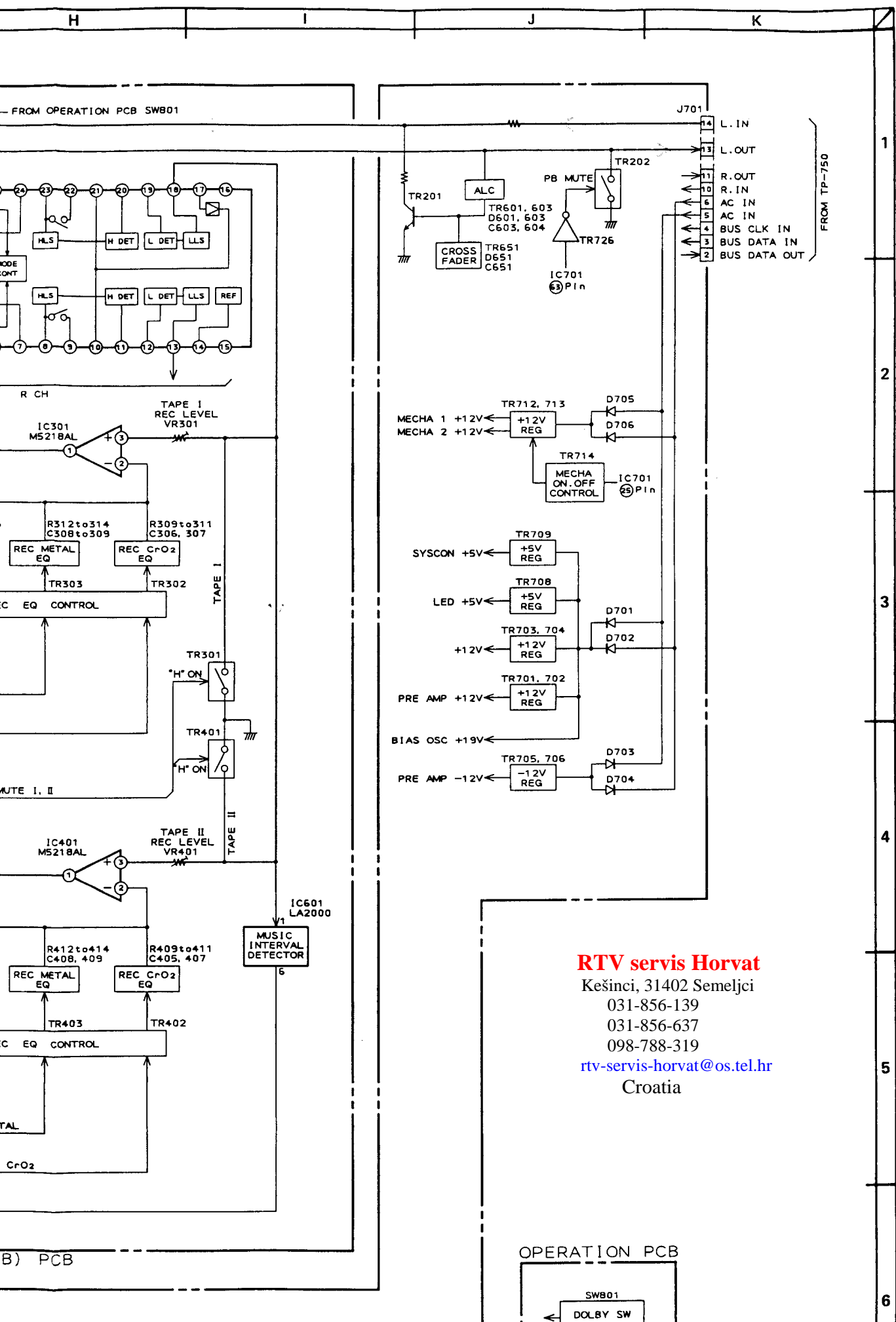

**RTV servis Horvat**

Kešinci, 31402 Semeljci

031-856-139

031-856-637

098-788-319

[rtv-servis-horvat@os.tel.hr](mailto:rtv-servis-horvat@os.tel.hr)

Croatia

3

4

5

6

7

8

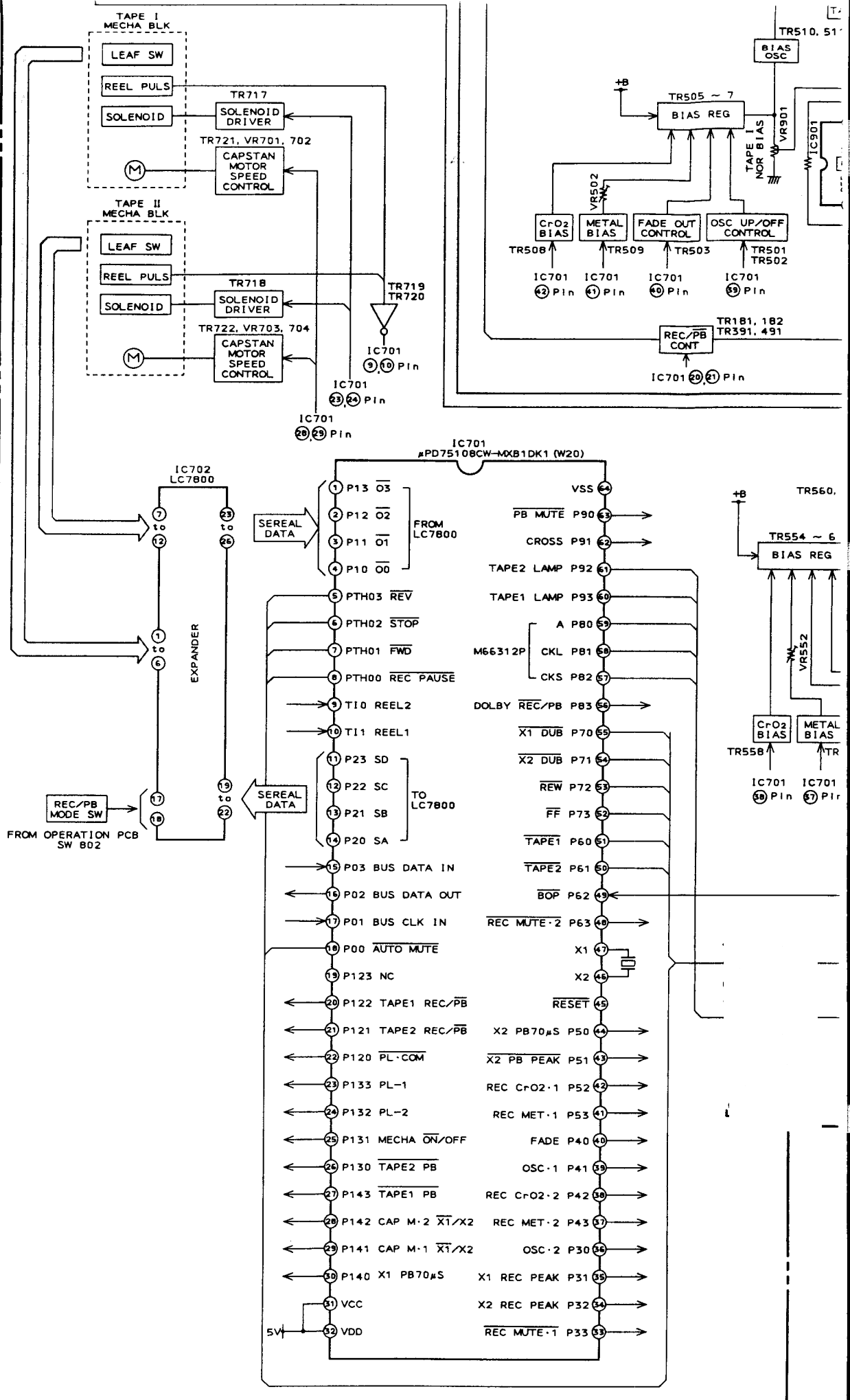

T/

TR510. 51'

BIAS OSC

TR505 ~ 7

BIAS REG

TAPE I NOR BIAS

CrO2 BIAS

TR508

IC701 (42) Pin

METAL BIAS

TR509

IC701 (41) Pin

FADE OUT CONTROL

TR503

IC701 (40) Pin

OSC UP/OFF CONTROL

TR501 TR502

IC701 (39) Pin

REC/PB CONT

TR181. 182 TR391. 491

IC701 (20, 21) Pin

IC701 µPD75108CW-MXB1DK1 (W20)

VSS (44)

PB MUTE P90 (43)

CROSS P91 (42)

TAPE2 LAMP P92 (41)

TAPE1 LAMP P93 (40)

A P80 (39)

M66312P CKL P81 (38)

CKS P82 (37)

DOLBY REC/PB P83 (36)

X1 DUB P70 (35)

X2 DUB P71 (34)

REW P72 (33)

FF P73 (32)

TAPE1 P60 (31)

TAPE2 P61 (30)

BOP P62 (29)

REC MUTE · 2 P63 (28)

X1 (47)

X2 (46)

RESET (45)

X2 PB70µS P50 (44)

X2 PB PEAK P51 (43)

REC CrO2 · 1 P52 (42)

REC MET · 1 P53 (41)

FADE P40 (40)

OSC · 1 P41 (39)

REC CrO2 · 2 P42 (38)

REC MET · 2 P43 (37)

OSC · 2 P30 (36)

X1 REC PEAK P31 (35)

X2 REC PEAK P32 (34)

REC MUTE · 1 P33 (33)

+B TR560.

TR554 ~ 6

BIAS REG

CrO2 BIAS

METAL BIAS

TR558

IC701 (38) Pin

TR

IC701 (37) Pin

SERIAL DATA

PTH03 REV

PTH02 STOP

PTH01 FWD

PTH00 REC PAUSE

TI0 REEL2

TI1 REEL1

P23 SD

P22 SC

P21 SB

P20 SA

P03 BUS DATA IN

P02 BUS DATA OUT

P01 BUS CLK IN

P00 AUTO MUTE

P123 NC

P122 TAPE1 REC/PB

P121 TAPE2 REC/PB

P120 PL · COM

P133 PL · 1

P132 PL · 2

P131 MECHA ON/OFF

P130 TAPE2 PB

P143 TAPE1 PB

P142 CAP M · 2 X1/X2

P141 CAP M · 1 X1/X2

P140 X1 PB70µS

VCC

VDD

IC702 LC7800

7 to 12

23 to 26

EXPANDER

1 to 6

REC/PB MODE SW

FROM OPERATION PCB SW 802

17 to 18

19 to 22

SERIAL DATA

TO LC7800

TO LC7800

TO LC7800

TO LC7800

TO LC7800

TO LC7800

TO LC7800

TO LC7800

TO LC7800

TO LC7800

TO LC7800

TO LC7800

TO LC7800

TO LC7800

TO LC7800

TO LC7800

TO LC7800



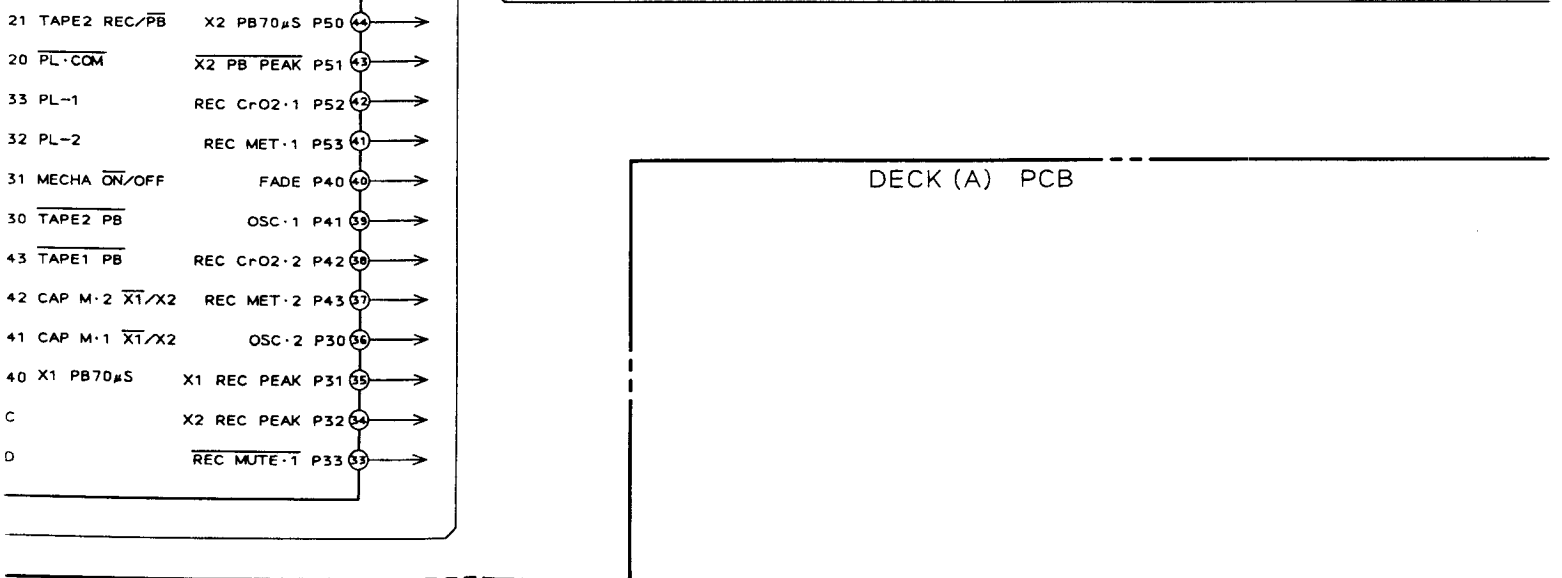
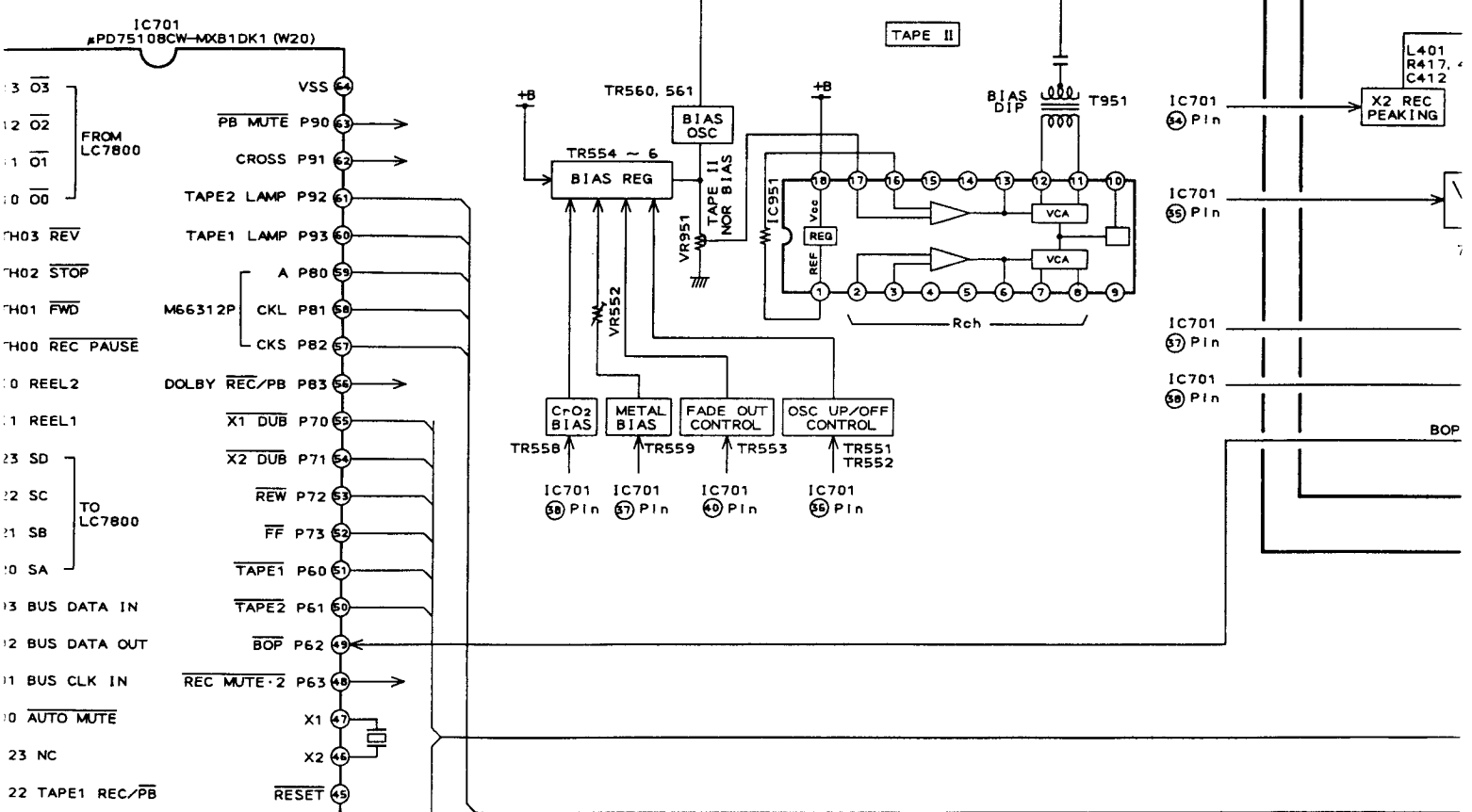
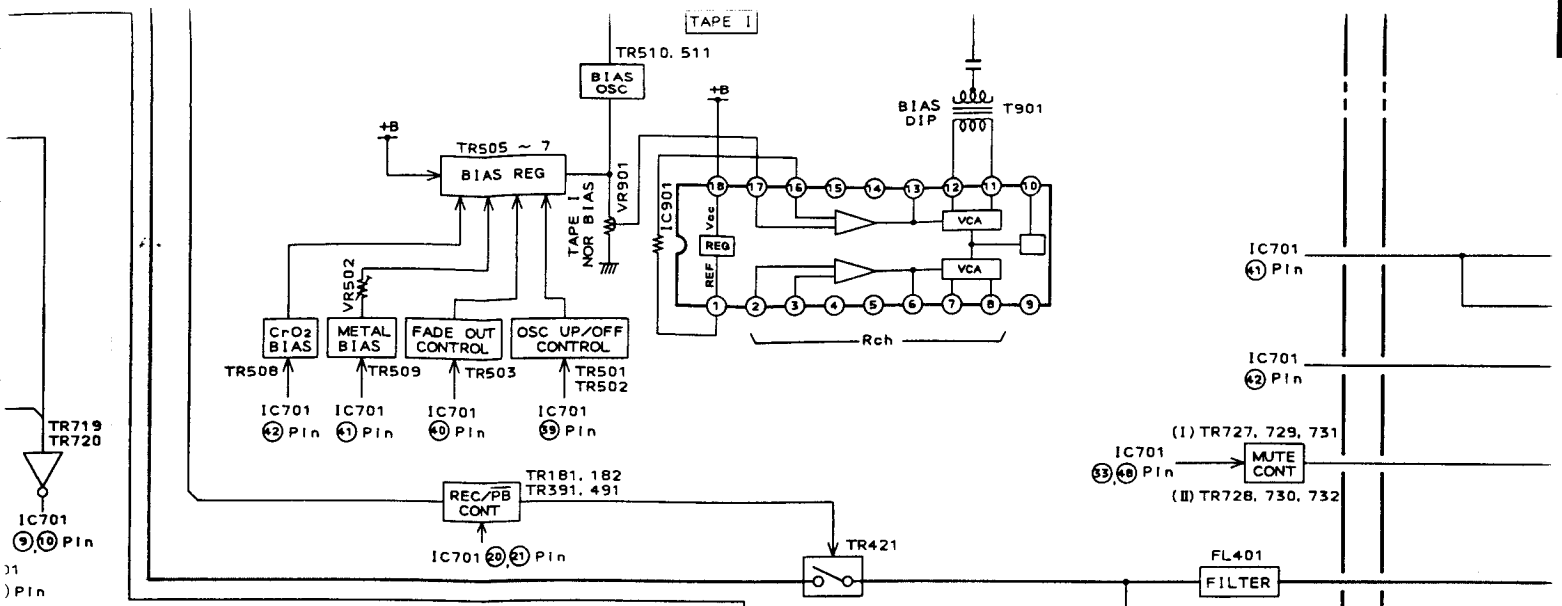

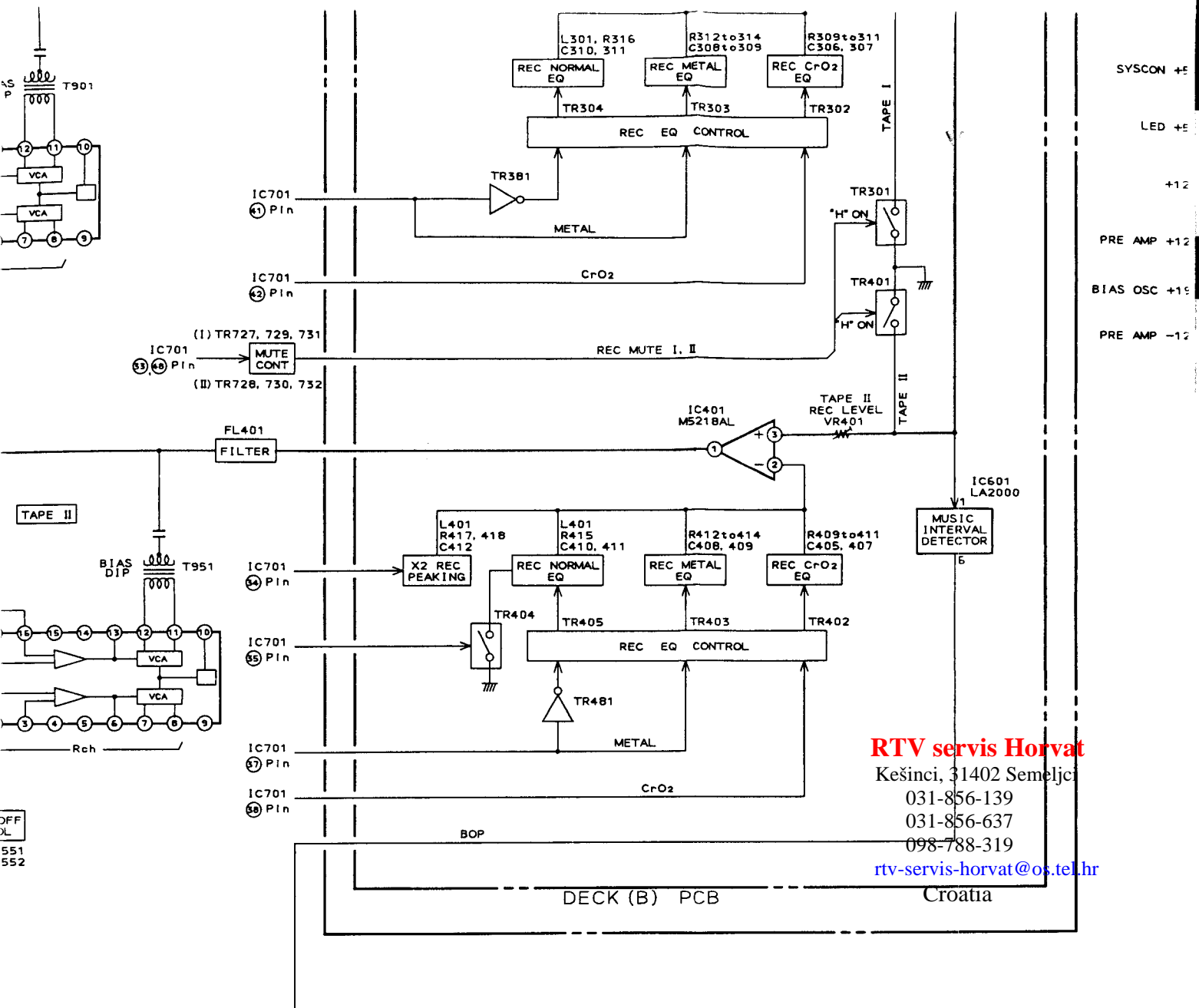

**RTV servis Horvat**  
 Kešinci, 31402 Semeljci  
 031-856-139  
 031-856-637  
 098-788-319  
[rtv-servis-horvat@os.tel.hr](mailto:rtv-servis-horvat@os.tel.hr)  
 Croatia

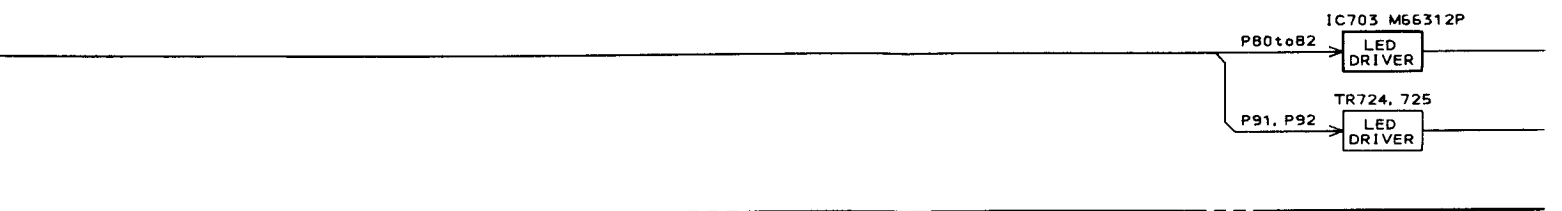

DECK (A) PCB

--- : PB SIGNAL LINE  
 --- : REC SIGNAL LINE

H  
D  
B

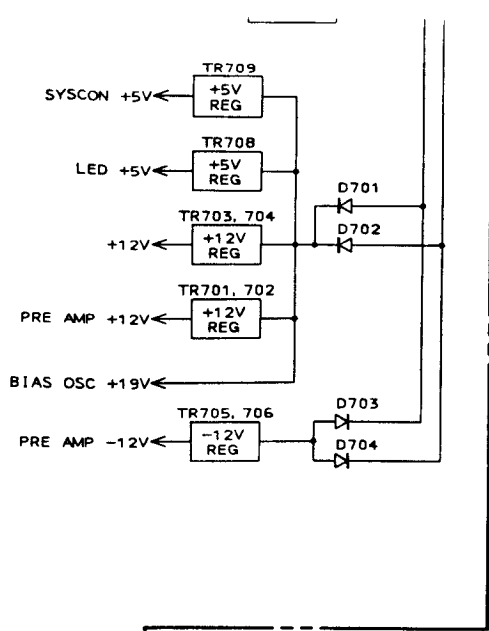
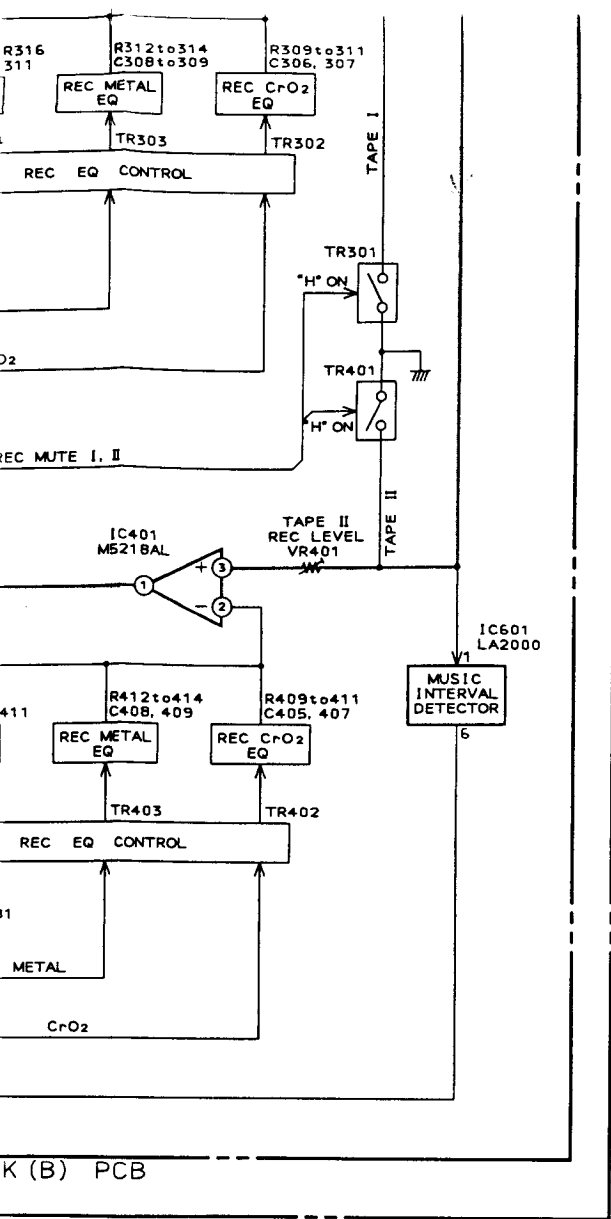

K (B) PCB

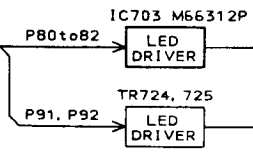
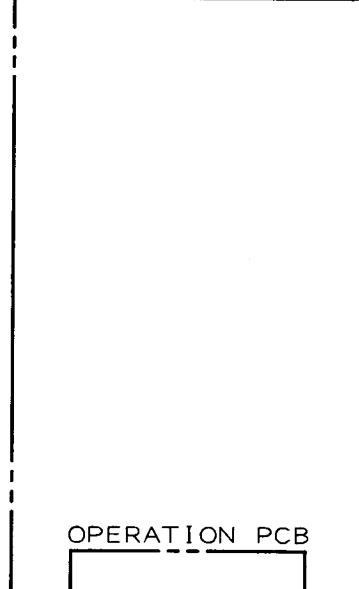

--- PB SIGNAL LINE  
 --- REC SIGNAL LINE

HX-950  
 DECK (A), (B) & OPERATION  
 BLOCK DIAGRAM  
 No. 5-4 T213551M  
 A1

3  
 4  
 5  
 6  
 7  
 8

1

2

3

4

5

6

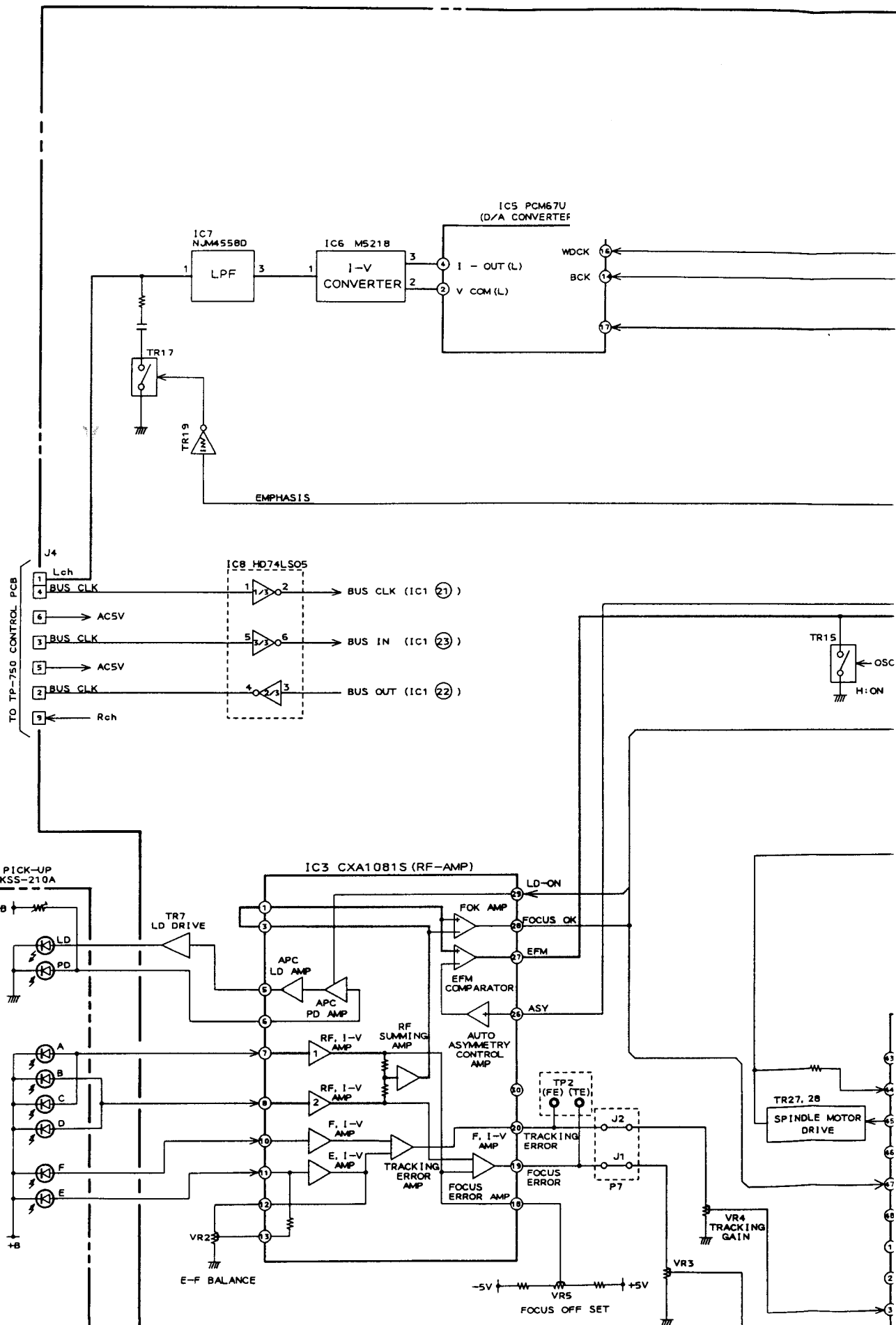

C

D

E

F

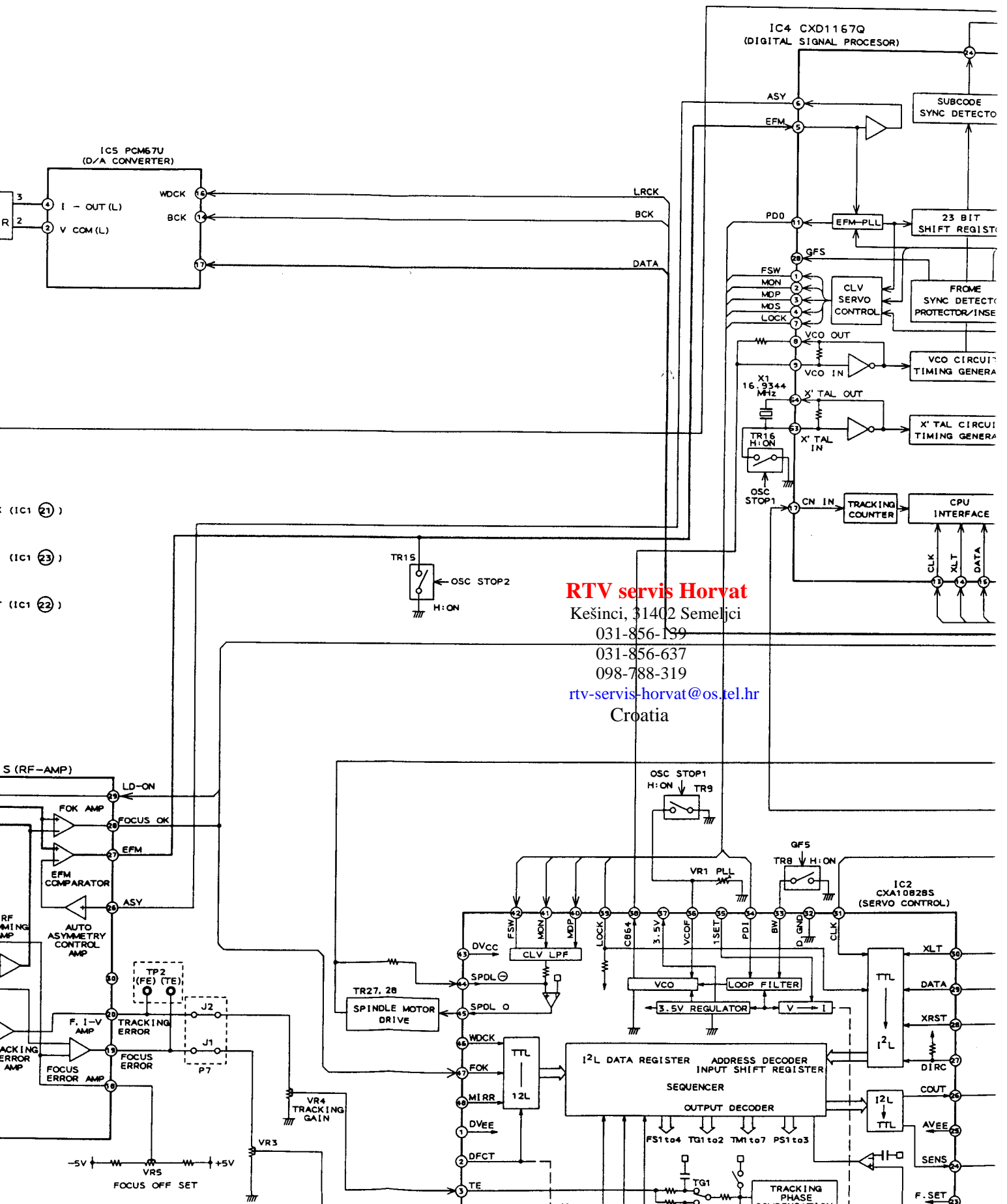

**RTV servis Horvat**

Kešinci, 31402 Semeljci

031-856-139

031-856-637

098-788-319

[rtv-servis-horvat@os.tel.hr](mailto:rtv-servis-horvat@os.tel.hr)

Croatia

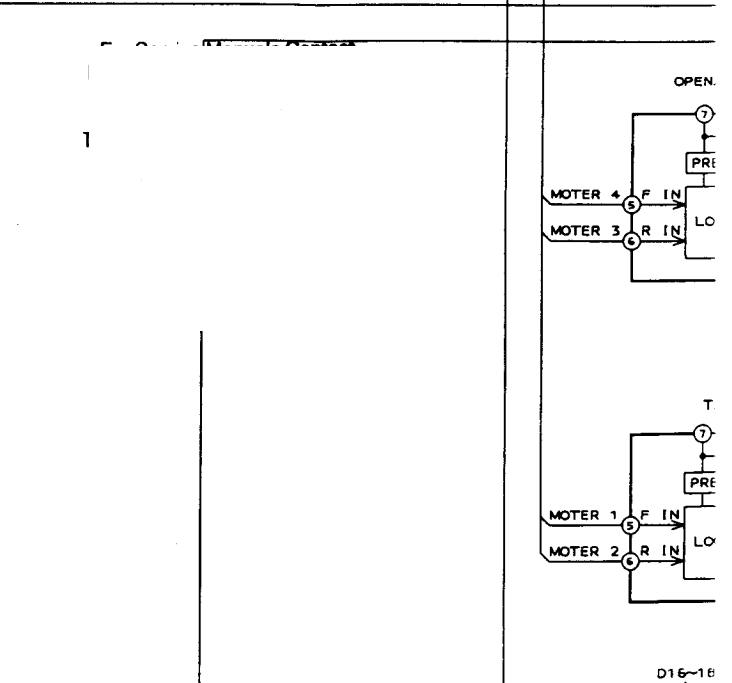
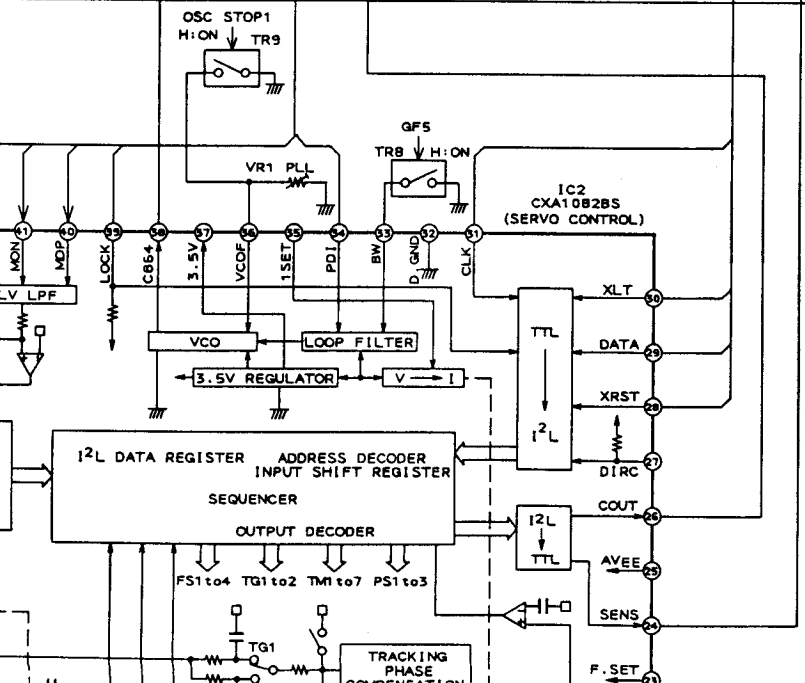
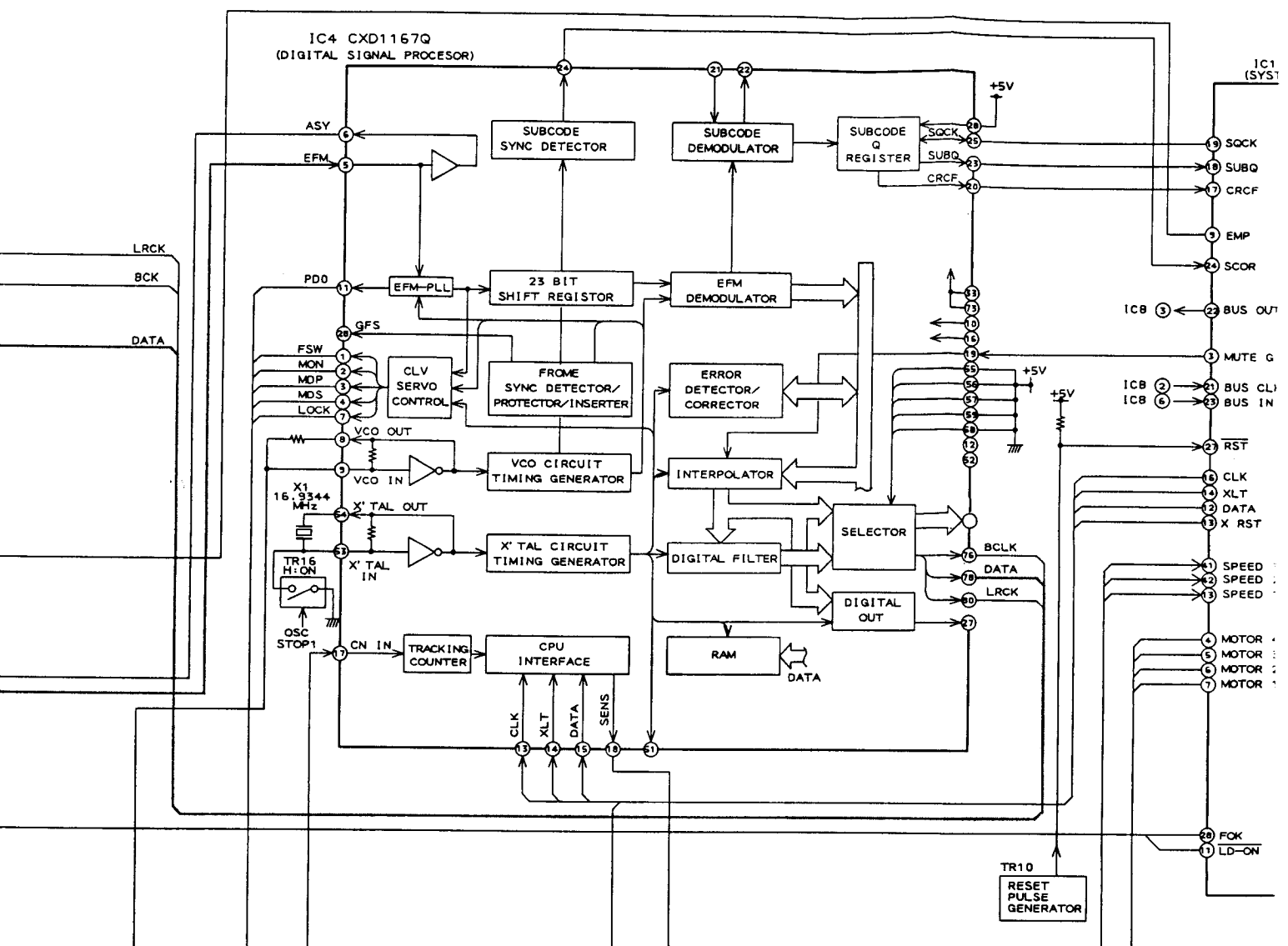

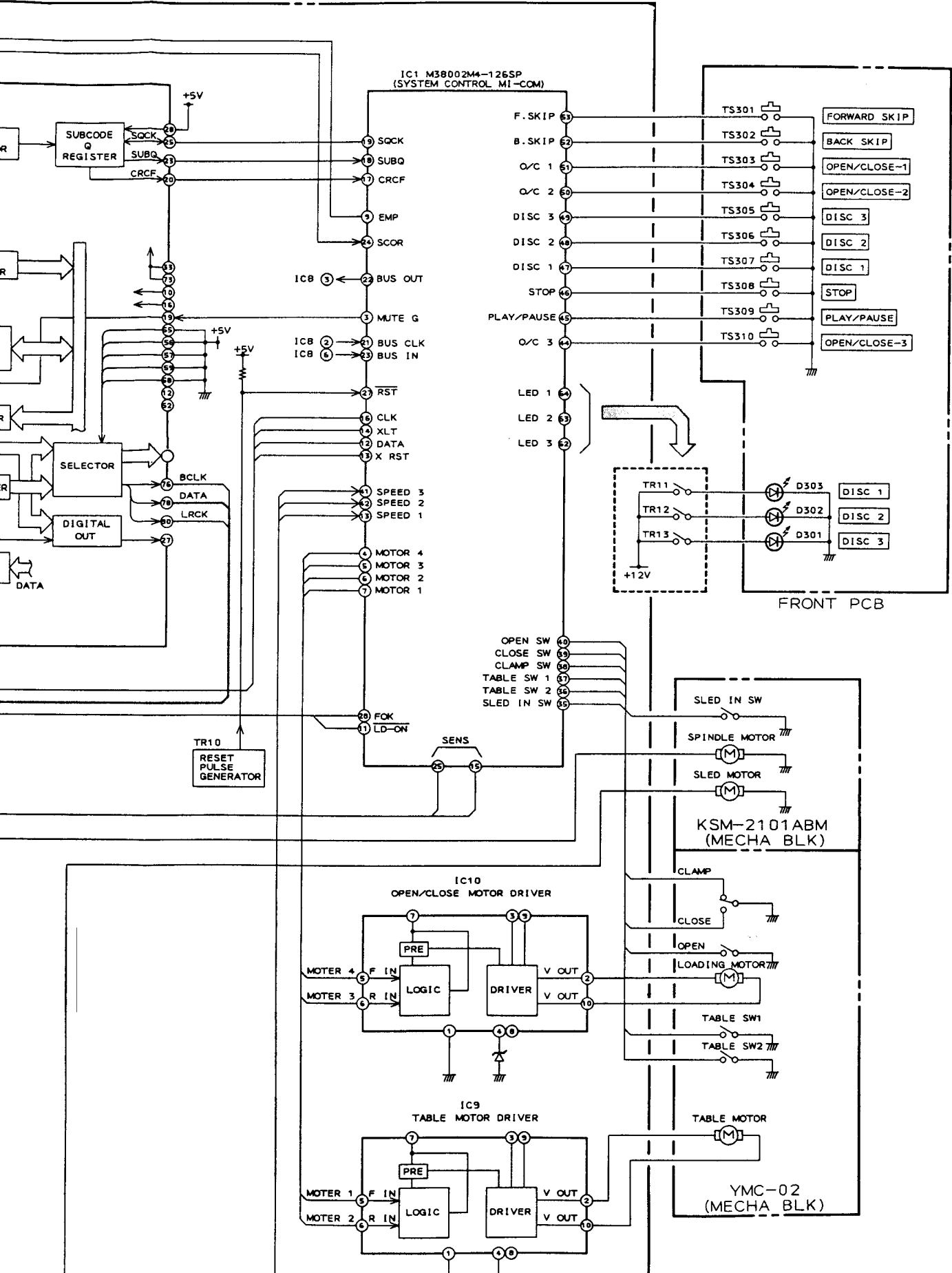

IC1 M38002M4-1265P  
(SYSTEM CONTROL MI-COM)

SUBCODE REGISTER  
SOCK  
SUBQ  
CRCF

SELECTOR  
DIGITAL OUT  
BCLK  
DATA  
LRCK

TR10  
RESET PULSE GENERATOR

IC10  
OPEN/CLOSE MOTOR DRIVER

IC9  
TABLE MOTOR DRIVER

KSM-2101ABM  
(MECHA BLK)

YMC-02  
(MECHA BLK)

FRONT PCB

- F. SKIP 53
- B. SKIP 52
- O/C 1 51
- O/C 2 50
- DISC 3 49
- DISC 2 48
- DISC 1 47
- STOP 46
- PLAY/PAUSE 45
- O/C 3 44
- LED 1 43
- LED 2 42
- LED 3 41
- TS301 FORWARD SKIP
- TS302 BACK SKIP
- TS303 OPEN/CLOSE-1
- TS304 OPEN/CLOSE-2
- TS305 DISC 3
- TS306 DISC 2
- TS307 DISC 1
- TS308 STOP
- TS309 PLAY/PAUSE
- TS310 OPEN/CLOSE-3

- SPEED 3 31
- SPEED 2 32
- SPEED 1 33
- MOTOR 4 34
- MOTOR 3 35
- MOTOR 2 36
- MOTOR 1 37

- OPEN SW 40
- CLOSE SW 41
- CLAMP SW 42
- TABLE SW 1 43
- TABLE SW 2 44
- SLED IN SW 45
- FOK 46
- LD-ON 47

IC10  
OPEN/CLOSE MOTOR DRIVER

IC9  
TABLE MOTOR DRIVER

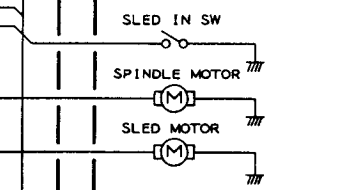
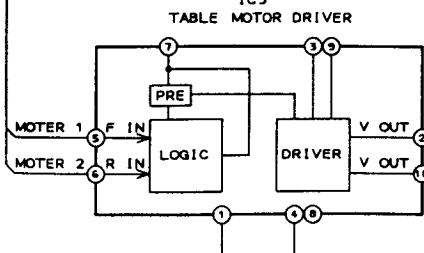
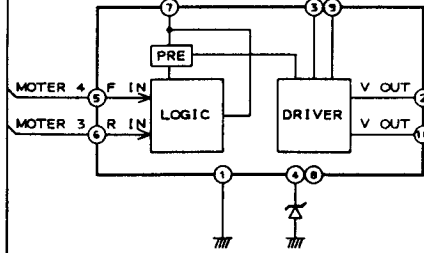
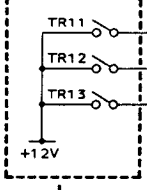
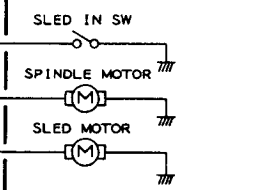

KSM-2101ABM  
(MECHA BLK)

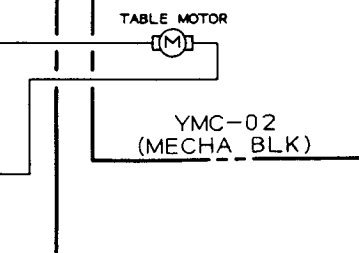
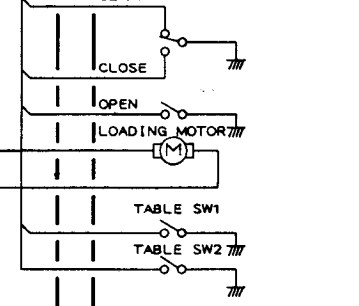

YMC-02  
(MECHA BLK)

3  
4  
5  
6  
7  
8

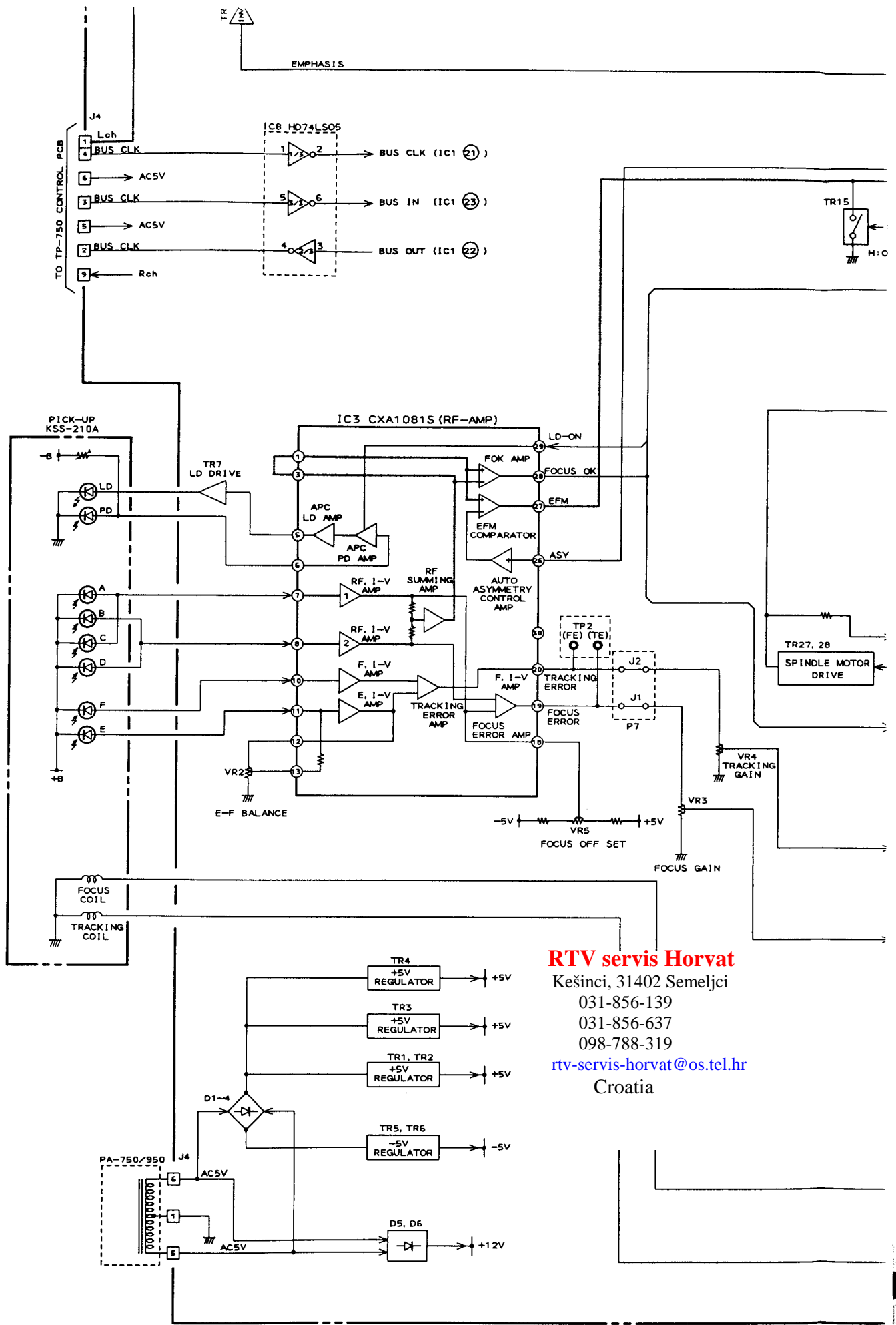

**RTV servis Horvat**  
 Kešinci, 31402 Semeljci  
 031-856-139  
 031-856-637  
 098-788-319  
[rtv-servis-horvat@os.tel.hr](mailto:rtv-servis-horvat@os.tel.hr)  
 Croatia



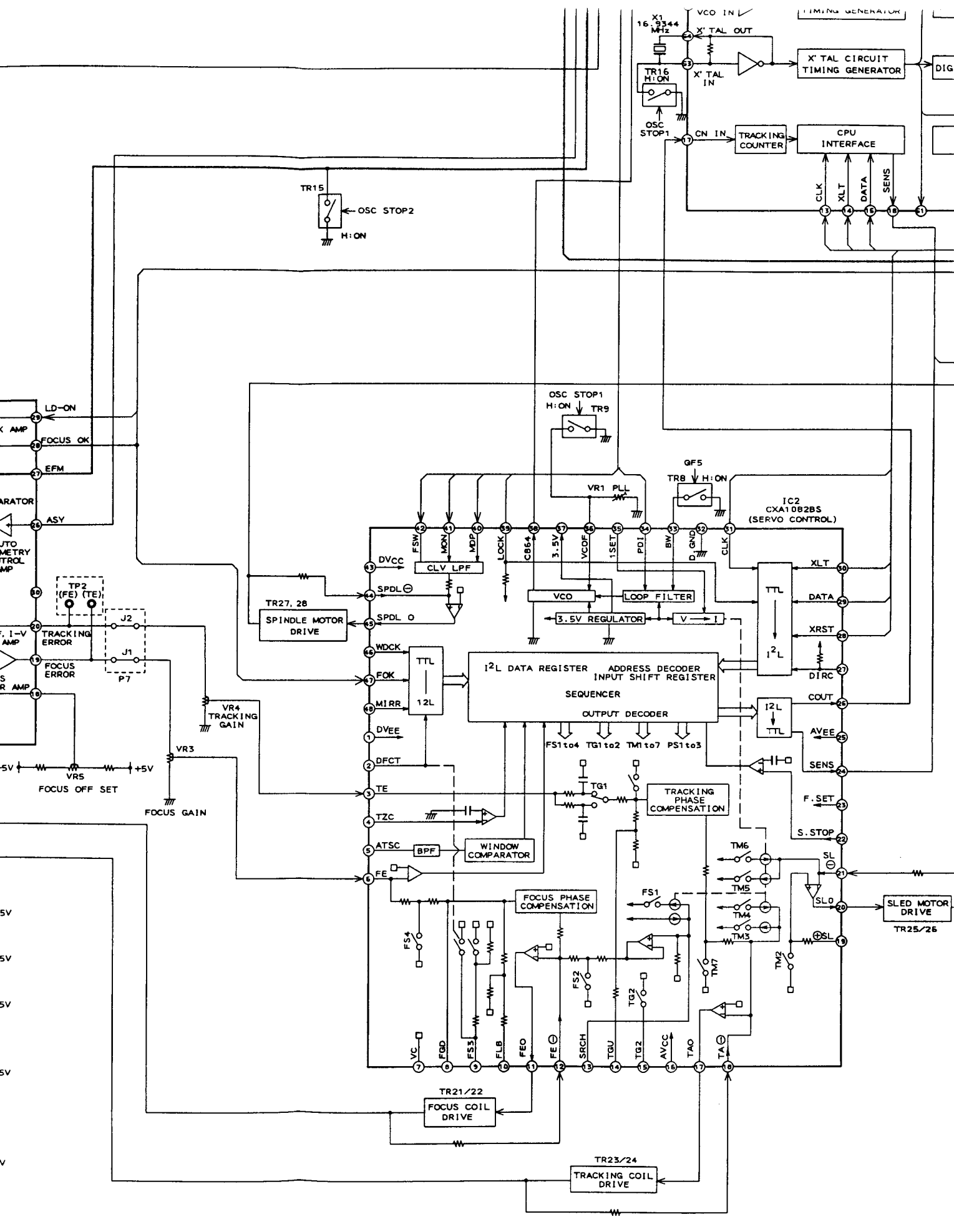
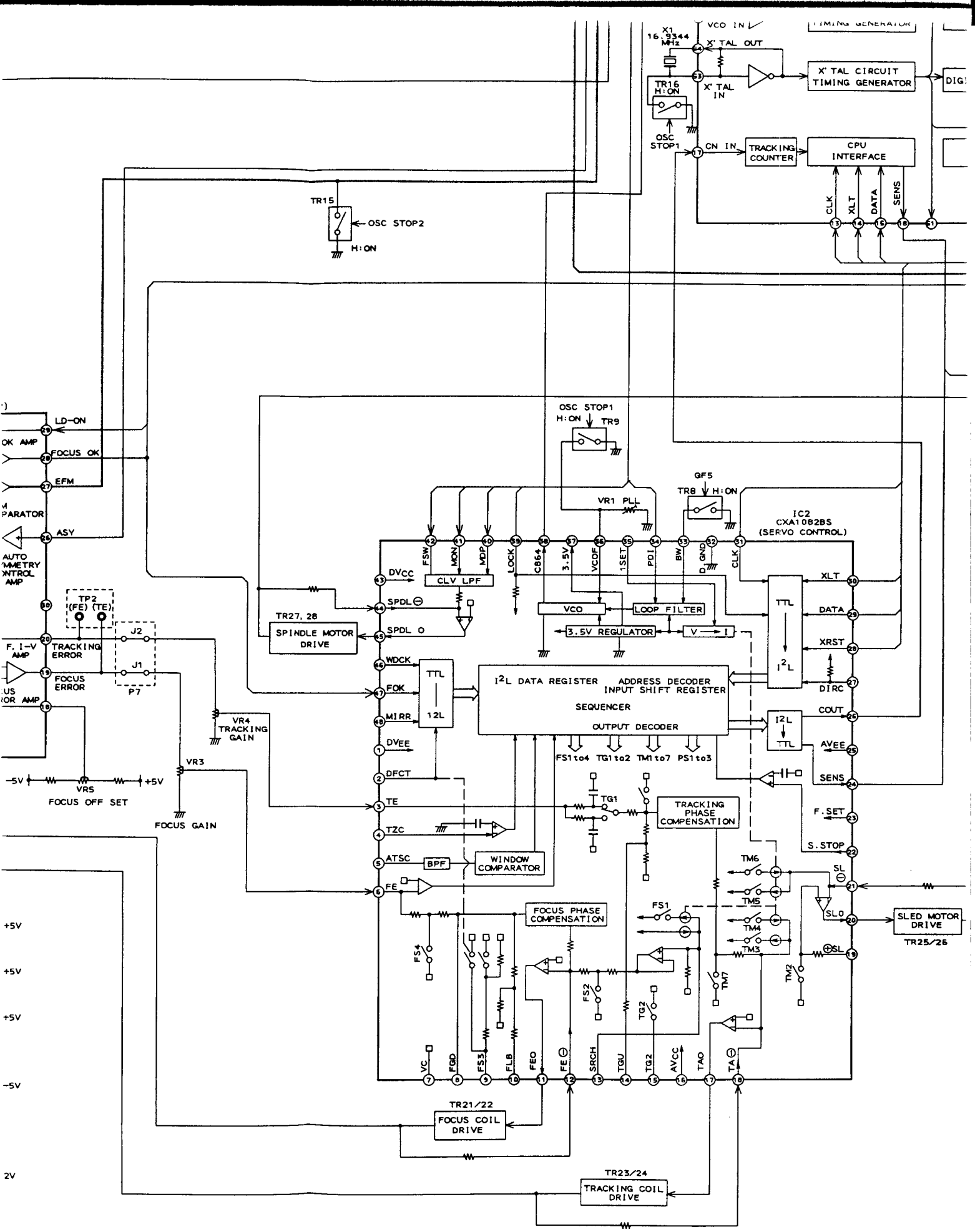

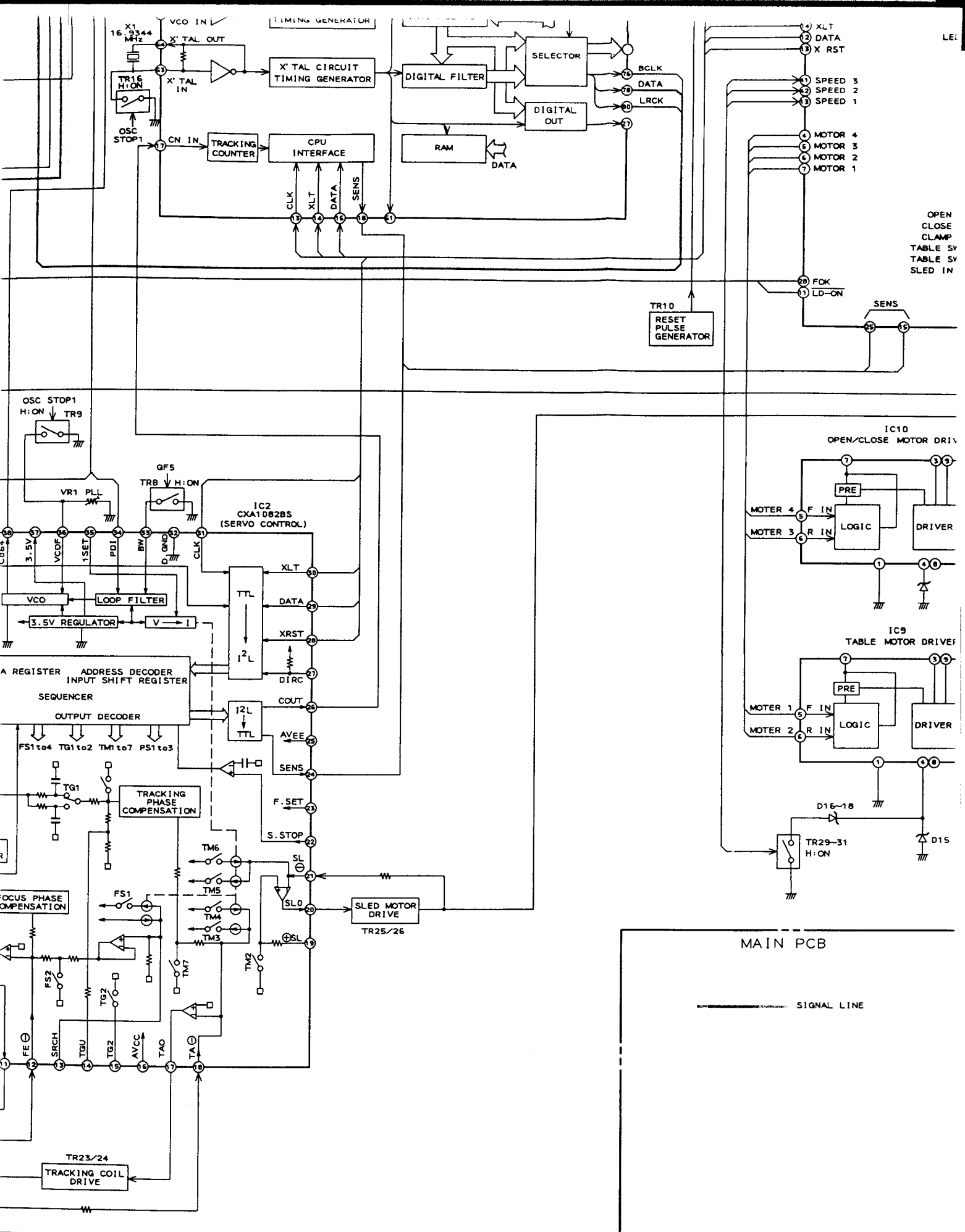

MAIN PCB

SIGNAL LINE

OPEN  
CLOSE  
CLAMP  
TABLE SV  
TABLE SV  
SLED IN

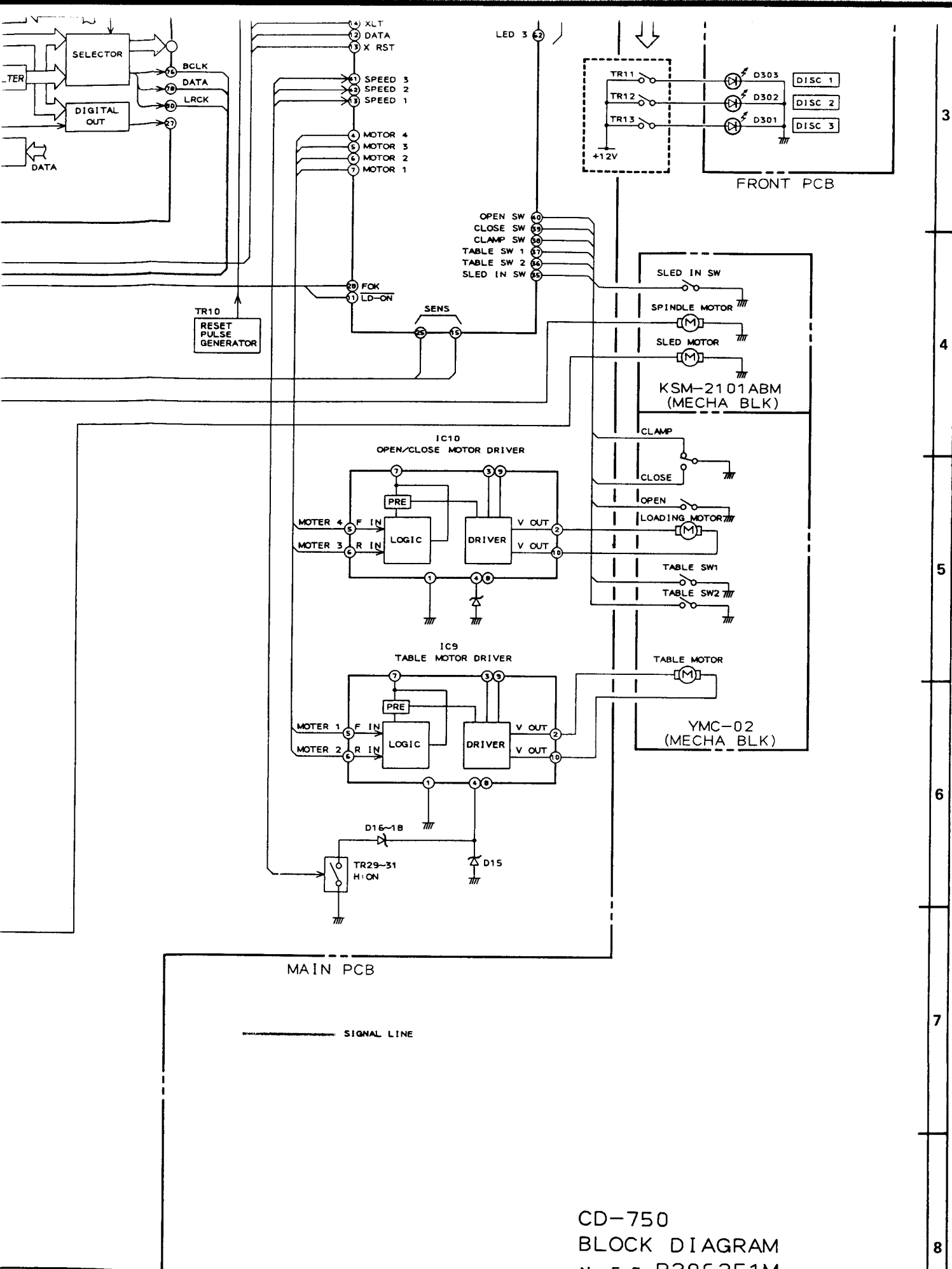

CD-750  
 BLOCK DIAGRAM  
 No. 5-5 P206251M  
 A1

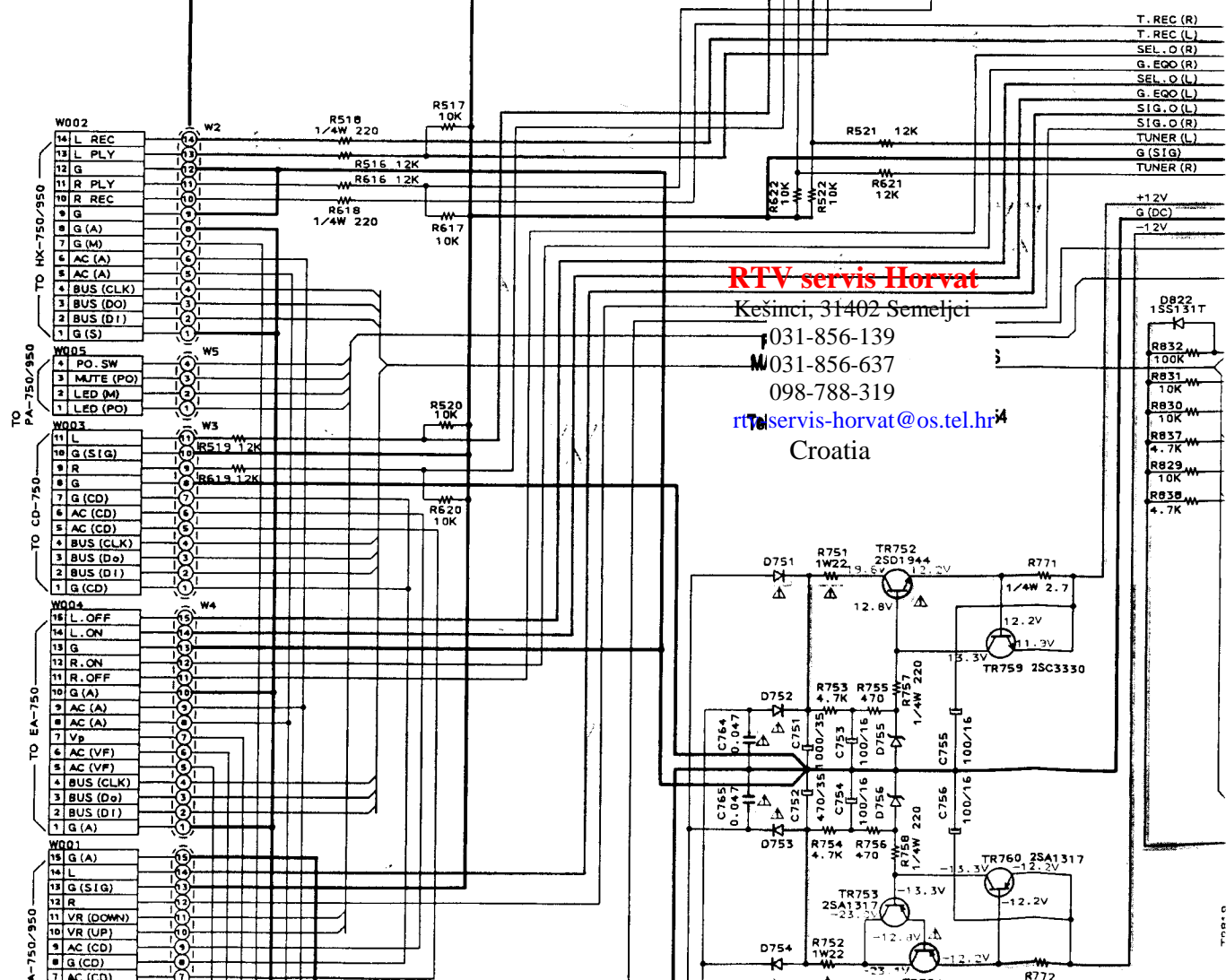
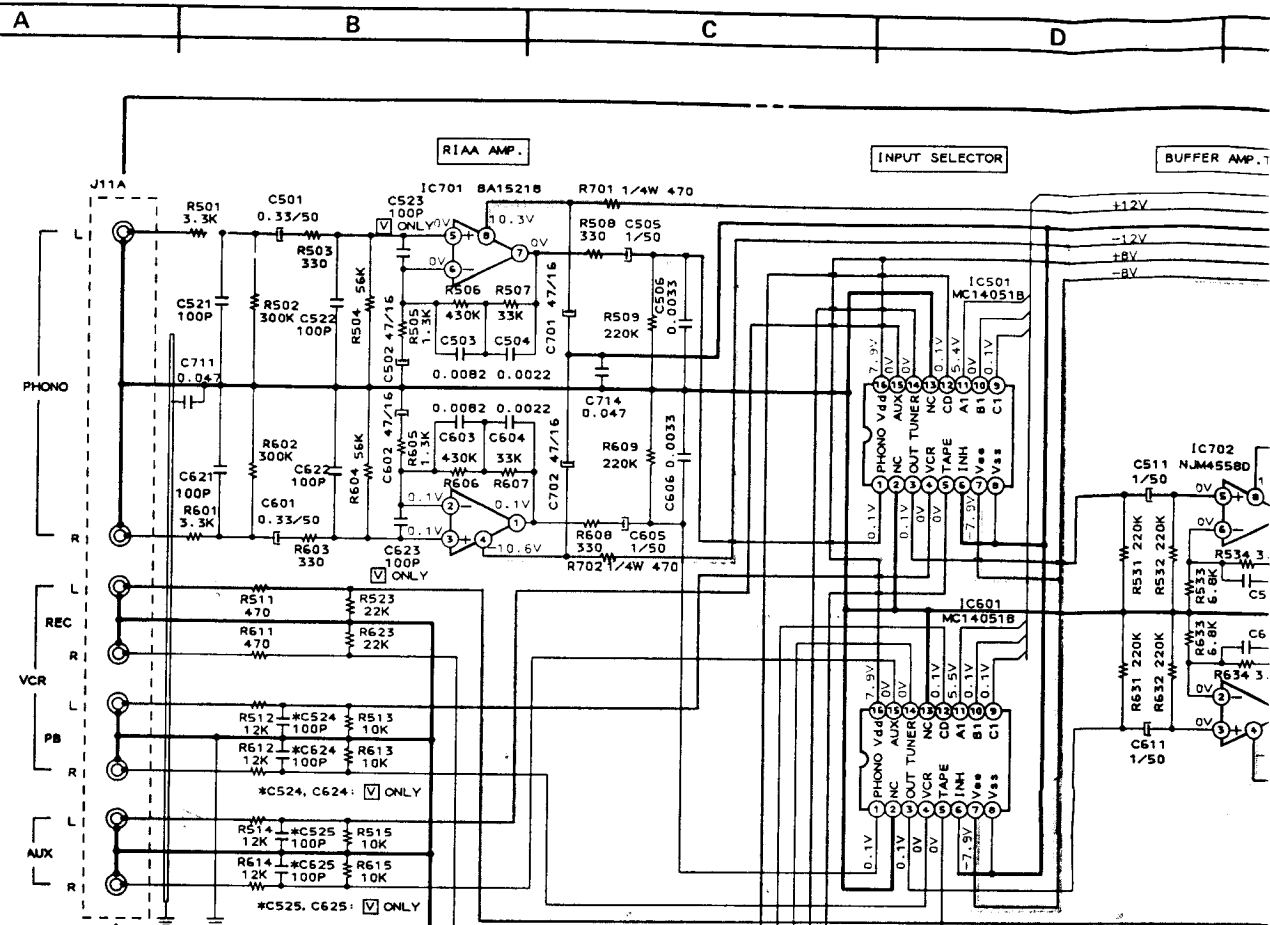

**RTV servis Horvat**  
 Kešinci, 31402 Semeljci  
 ☎031-856-139  
 ☎031-856-637  
 ☎098-788-319  
 ✉rtvservis-horvat@os.tel.hr  
 Croatia

IAA AMP.

INPUT SELECTOR

BUFFER AMP. TOR

SOURCE DIRECT SW.  
REC OUT SW.

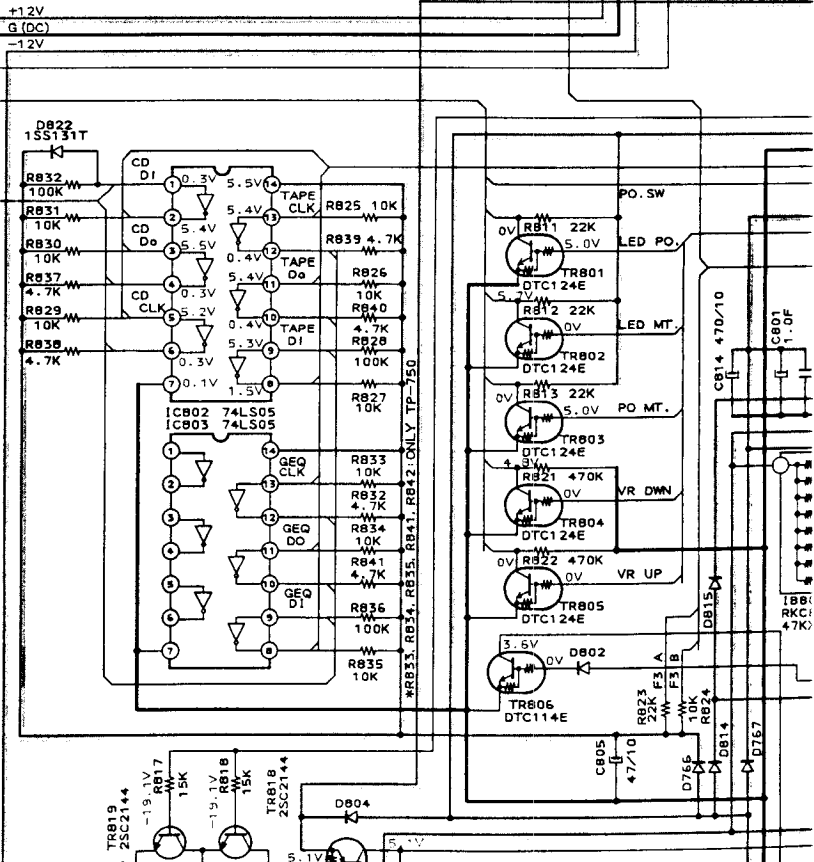
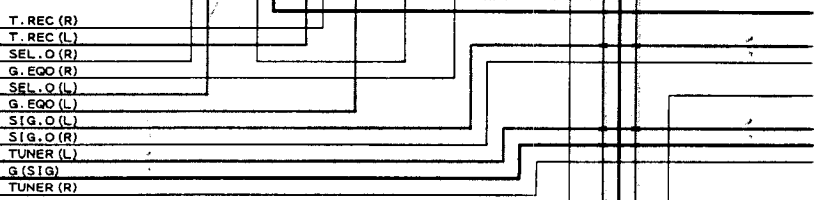
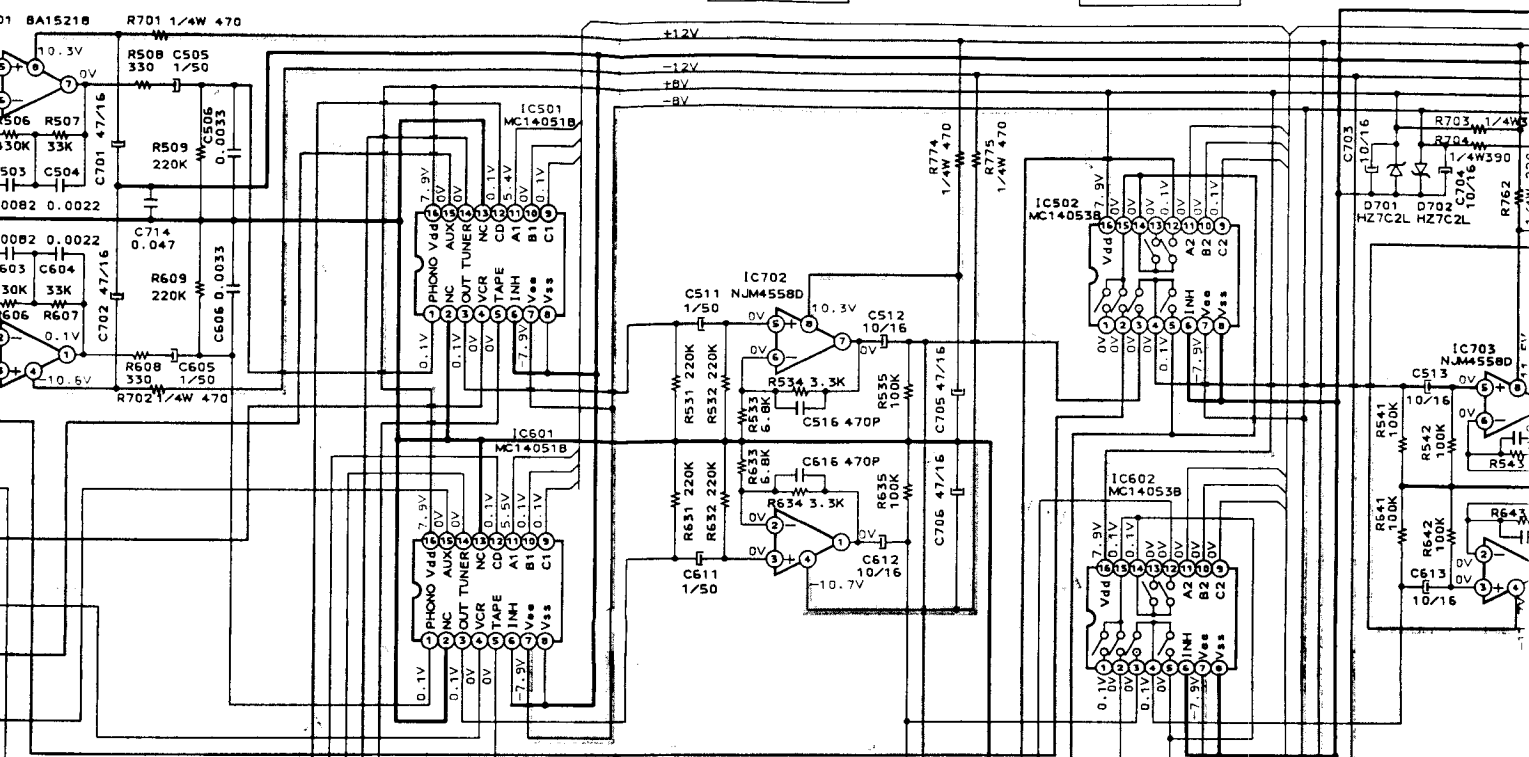

SOURCE DIRECT SW.  
REC OUT SW.

SUPER BASS

MUTE

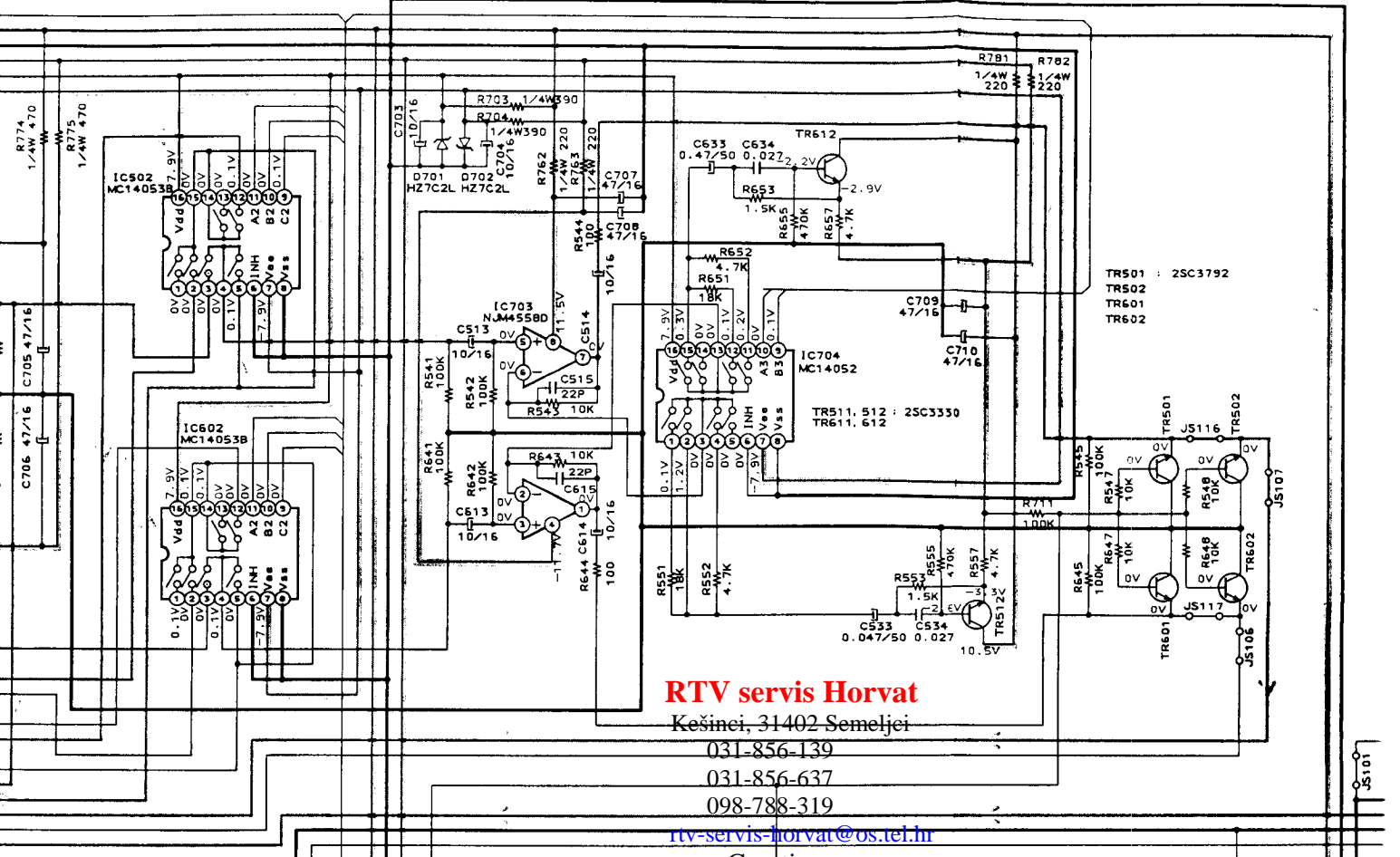

**RTV servis Horvat**

Kesinec, 31402 Semeljei

031-856-139

031-856-637

098-788-319

[rtv-servis-horvat@os.tel.hr](mailto:rtv-servis-horvat@os.tel.hr)

Croatia

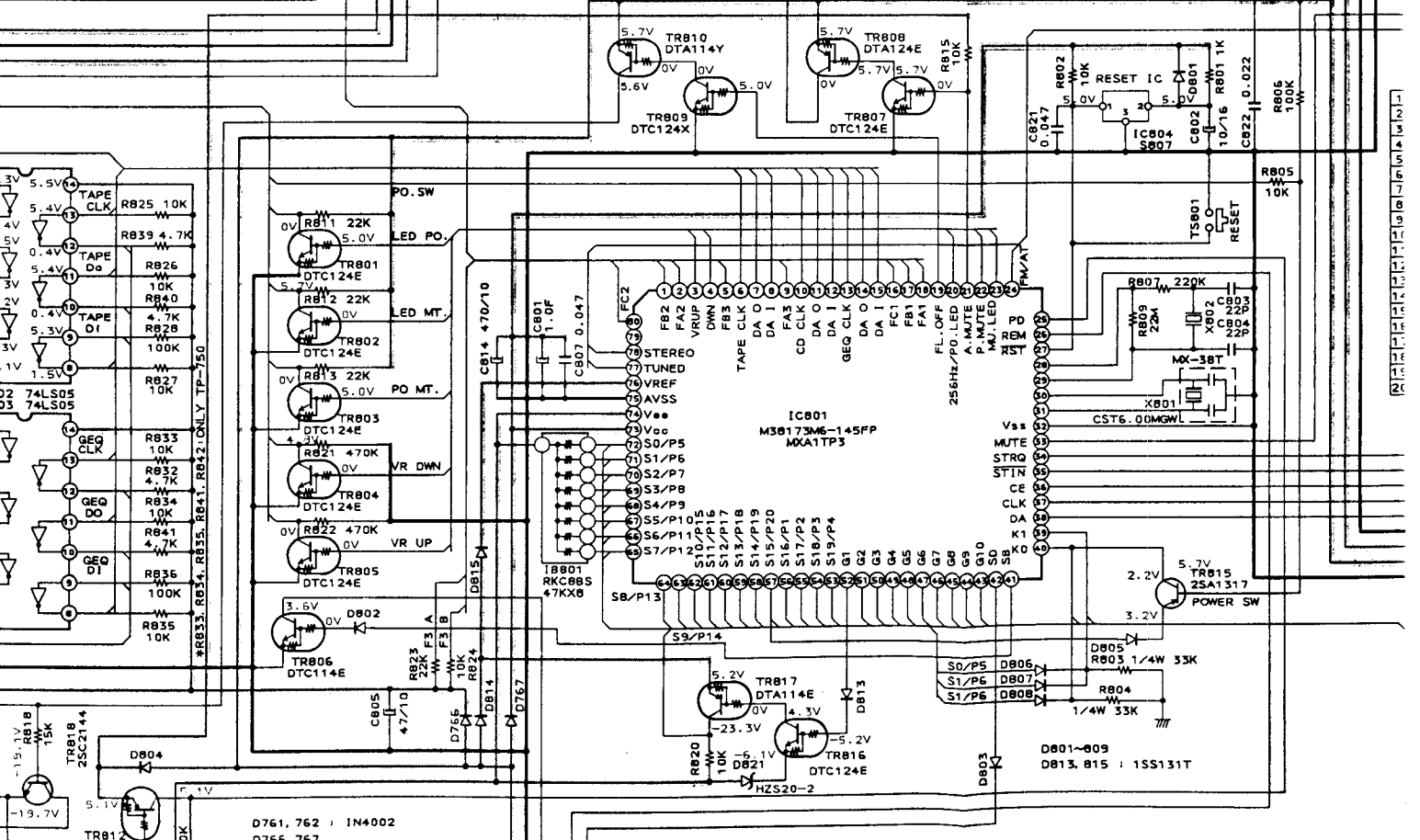

1  
2  
3  
4  
5  
6  
7  
8  
9  
10  
11  
12  
13  
14  
15  
16  
17  
18  
19  
20  
21  
22  
23  
24  
25  
26  
27  
28  
29  
30  
31  
32  
33  
34  
35  
36  
37  
38  
39  
40  
41  
42  
43  
44  
45  
46  
47  
48  
49  
50  
51  
52  
53  
54  
55  
56  
57  
58  
59  
60  
61  
62  
63  
64  
65  
66  
67  
68  
69  
70  
71  
72  
73  
74  
75  
76  
77  
78  
79  
80  
81  
82  
83  
84  
85  
86  
87  
88  
89  
90  
91  
92  
93  
94  
95  
96  
97  
98  
99  
100

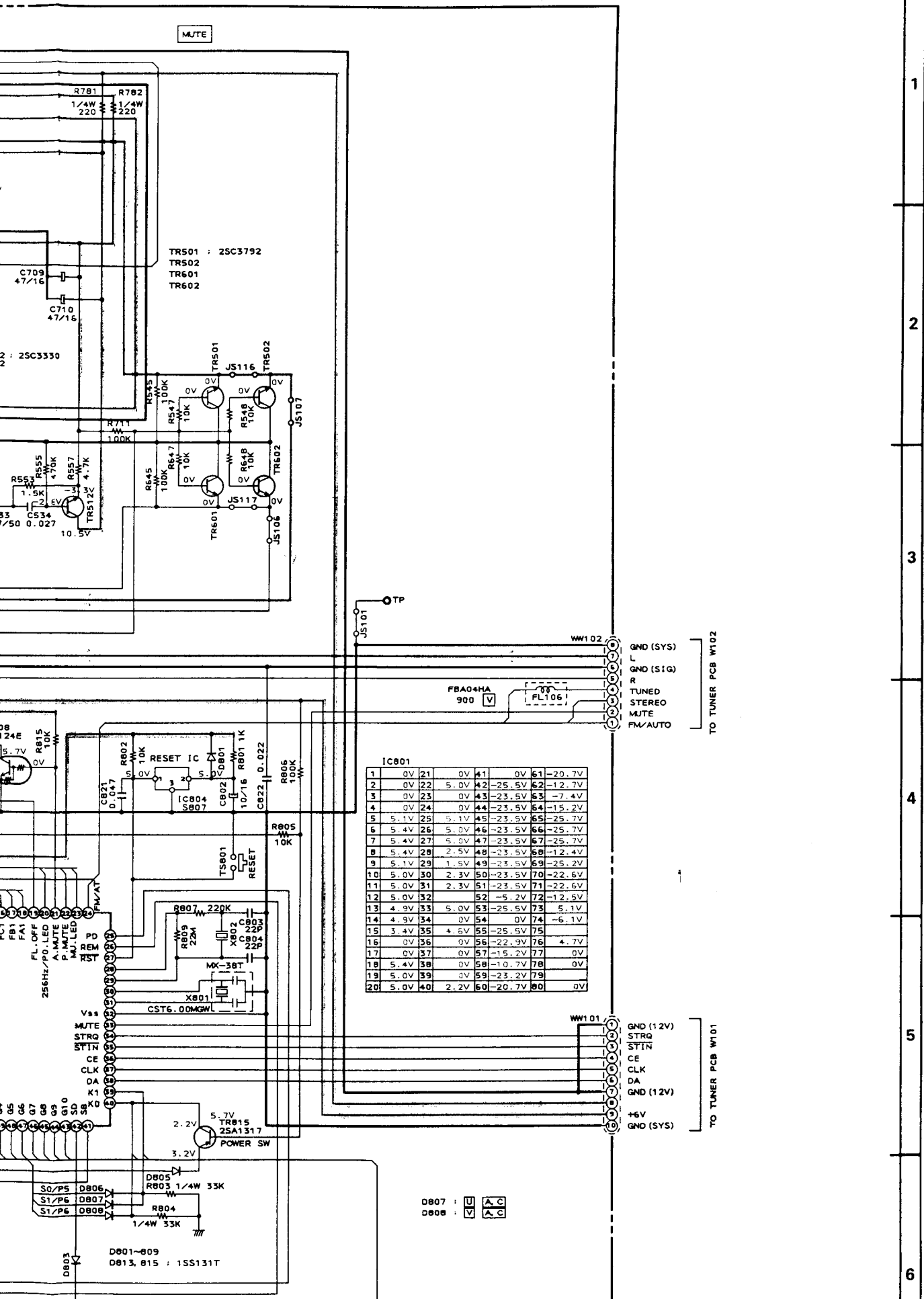

1  
2  
3  
4  
5  
6

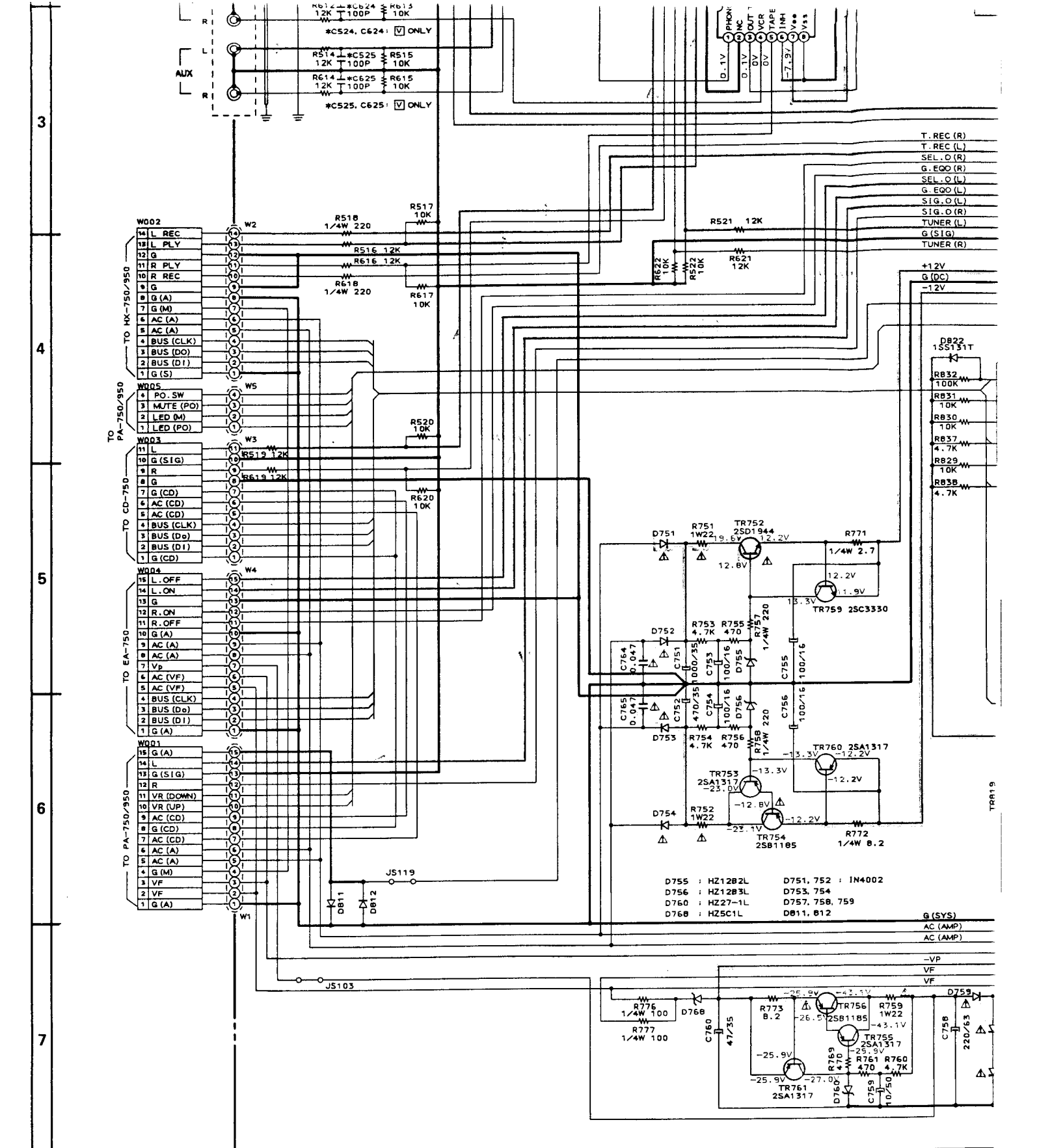

CONTROL PCB A6007A502B

INDICATED VOLTA DURING FM STERE

B (PC  
AUD)



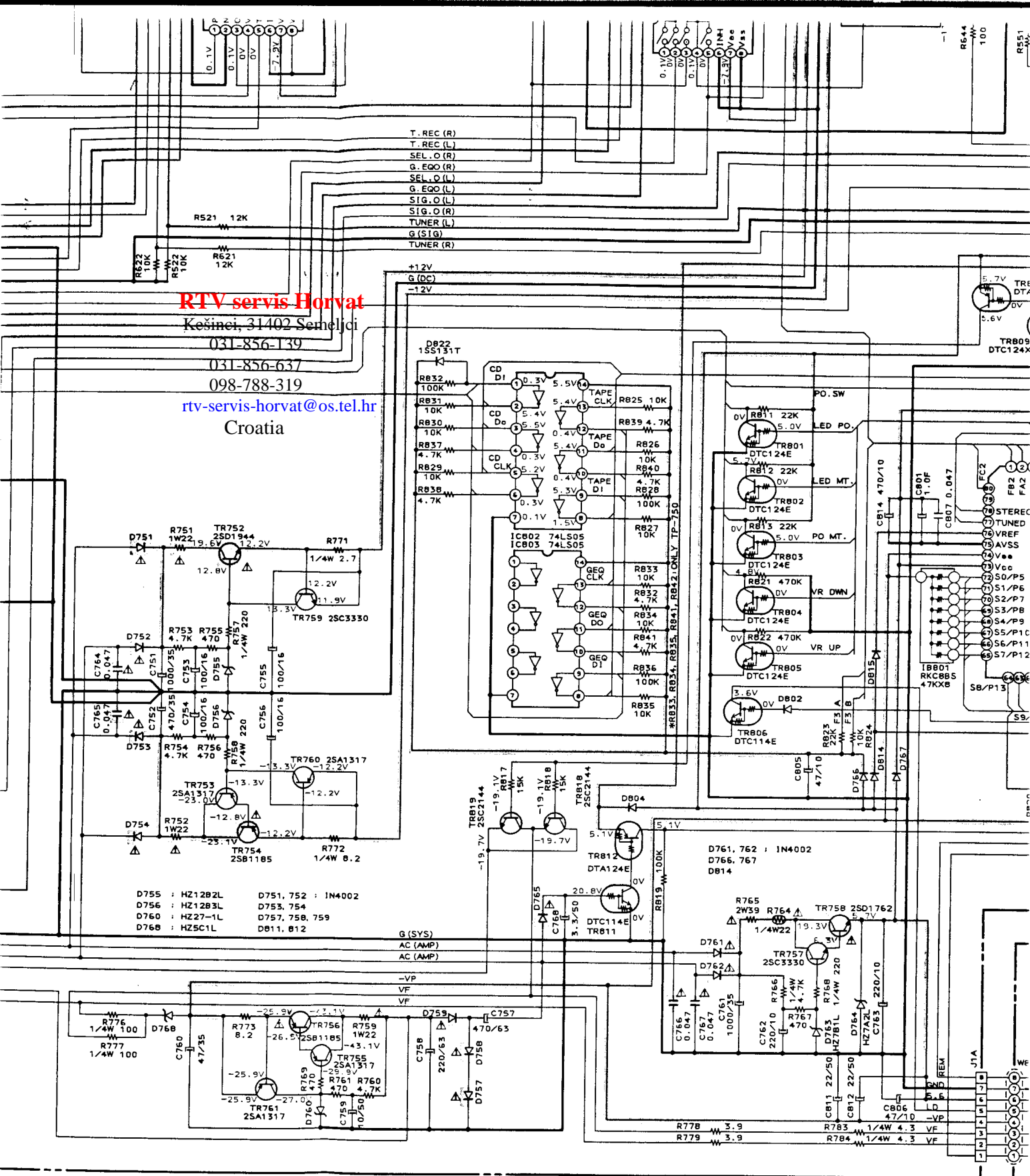

**RTV servis Horvat**  
 Kešinci, 31402 Semeljci  
 031-856-139  
 031-856-637  
 098-788-319  
 rtv-servis-horvat@os.tel.hr  
 Croatia

6007A502B

INDICATED VOLTAGES WERE MEASURED DURING FM STEREO MODE.

NOTE UNLESS OTHERWISE SPECIFIED ALL RESISTORS IN OHMS 1/6W(J) ALL CAPACITORS IN μF

B (POWER SUPPLY) LINE  
 AUDIO SIGNAL LINE (L-CH)

WARNING: Δ AND INDICATE SAFETY CRITICAL COMPONENTS FOR CONTINUED SAFETY. REPLACE SAFETY CRITICAL COMPONENTS ONLY WITH MANUFACTURER'S RECOMMENDED PARTS

AVERTISSEMENT: Δ ET ILS INDIQUENT LES COMPOSANTS CRITIQUES DE SÉCURITÉ. POUR MAINTENIR LE DEGRÉ DE SÉCURITÉ DE L'APPAREIL, NE REMPLACER QUE DES PIÈCES RECOMMANDÉES PAR LE FABRICANT

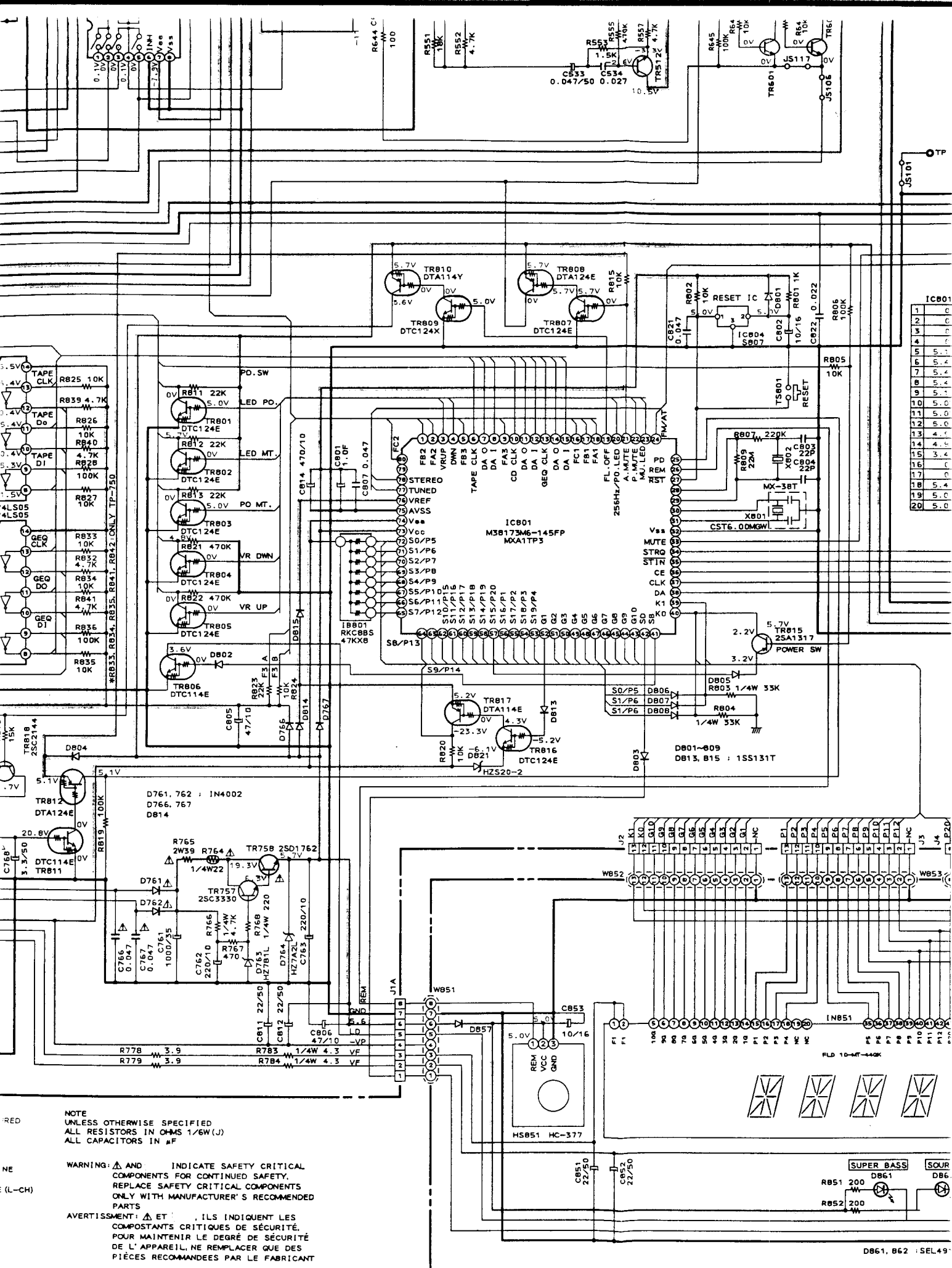

IC801	1	C
	2	C
	3	C
	4	F
	5	F
	6	S
	7	S
	8	S
	9	S
	10	S
	11	S
	12	S
	13	F
	14	F
	15	C
	16	C
	17	C
	18	S
	19	S
	20	S

NOTE  
 UNLESS OTHERWISE SPECIFIED  
 ALL RESISTORS IN OHMS 1/4W(J)  
 ALL CAPACITORS IN  $\mu$ F

WARNING:  $\Delta$  AND  $\nabla$  INDICATE SAFETY CRITICAL COMPONENTS FOR CONTINUED SAFETY. REPLACE SAFETY CRITICAL COMPONENTS ONLY WITH MANUFACTURER'S RECOMMENDED PARTS

AVERTISSEMENT:  $\Delta$  ET  $\nabla$  ILS INDICENT LES COMPOSANTS CRITIQUES DE SÉCURITÉ. POUR MAINTENIR LE DEGRÉ DE SÉCURITÉ DE L'APPAREIL, NE REMPLACER QUE DES PIÈCES RECOMMANDÉES PAR LE FABRICANT

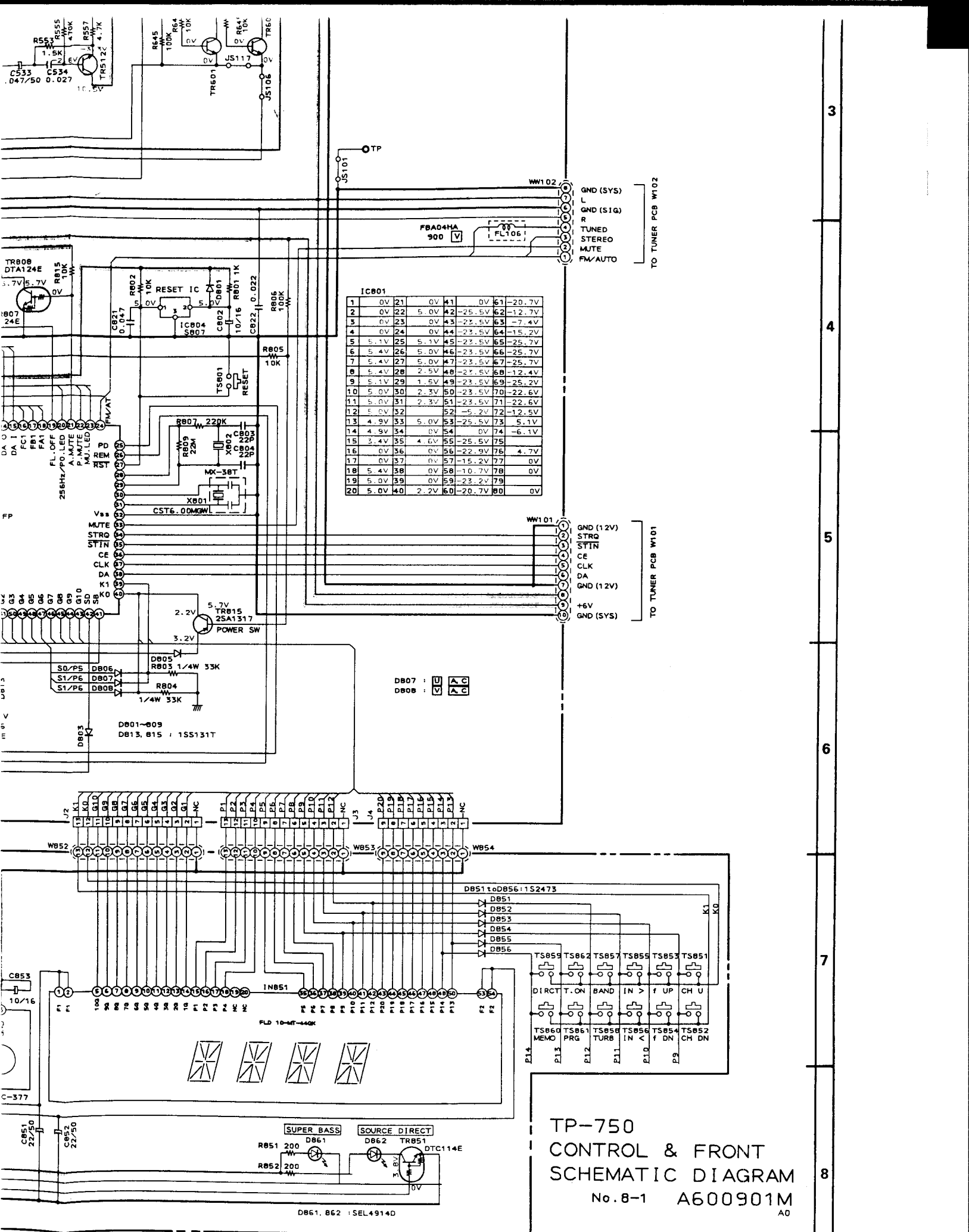

IC801

1	0V	21	0V	41	0V	61	-20.7V
2	0V	22	5.0V	42	-25.5V	62	-12.7V
3	0V	23	0V	43	-23.5V	63	-7.4V
4	0V	24	0V	44	-23.5V	64	-15.2V
5	5.1V	25	5.1V	45	-23.5V	65	-25.7V
6	5.4V	26	5.0V	46	-23.5V	66	-25.7V
7	5.4V	27	5.0V	47	-23.5V	67	-25.7V
8	5.4V	28	2.5V	48	-23.5V	68	-12.4V
9	5.1V	29	1.5V	49	-23.5V	69	-25.2V
10	5.0V	30	2.3V	50	-23.5V	70	-22.6V
11	5.0V	31	2.3V	51	-23.5V	71	-22.6V
12	5.0V	32	0V	52	-5.2V	72	-12.5V
13	4.9V	33	5.0V	53	-25.5V	73	5.1V
14	4.9V	34	0V	54	0V	74	-6.1V
15	3.4V	35	4.0V	55	-25.5V	75	0V
16	0V	36	0V	56	-22.9V	76	4.7V
17	0V	37	0V	57	-15.2V	77	0V
18	5.4V	38	0V	58	-10.7V	78	0V
19	5.0V	39	0V	59	-23.2V	79	0V
20	5.0V	40	2.2V	60	-20.7V	80	0V

TO TUNER PCB W102

GND (SYS)  
L  
GND (SIG)  
R  
TUNED  
STEREO  
MUTE  
FM/AUTO

TO TUNER PCB W101

GND (12V)  
STRQ  
STIN  
CE  
CLK  
DA  
GND (12V)  
+6V  
GND (SYS)

TP-750  
CONTROL & FRONT  
SCHEMATIC DIAGRAM  
No. 8-1 A600901M  
A0

3  
4  
5  
6  
7  
8

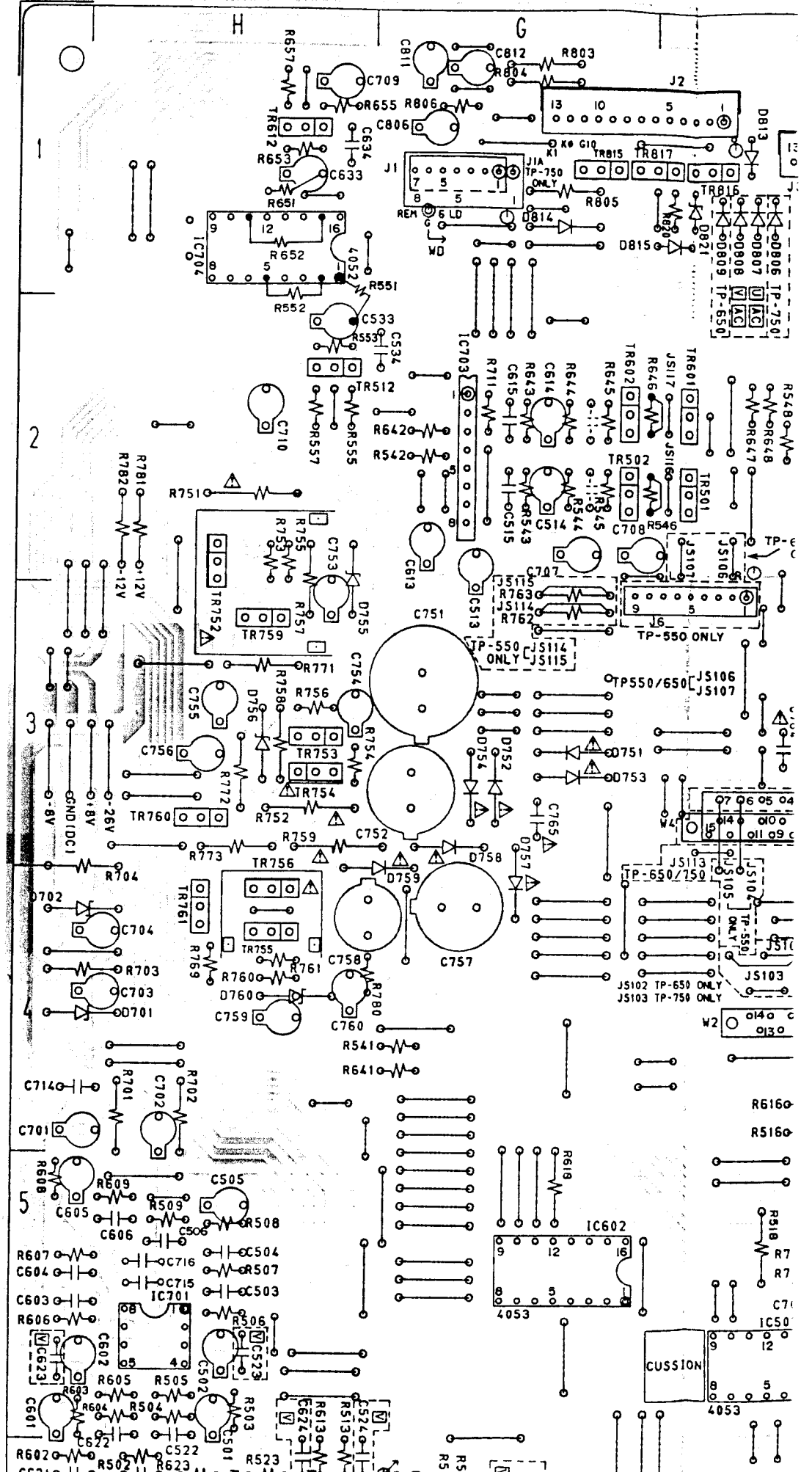

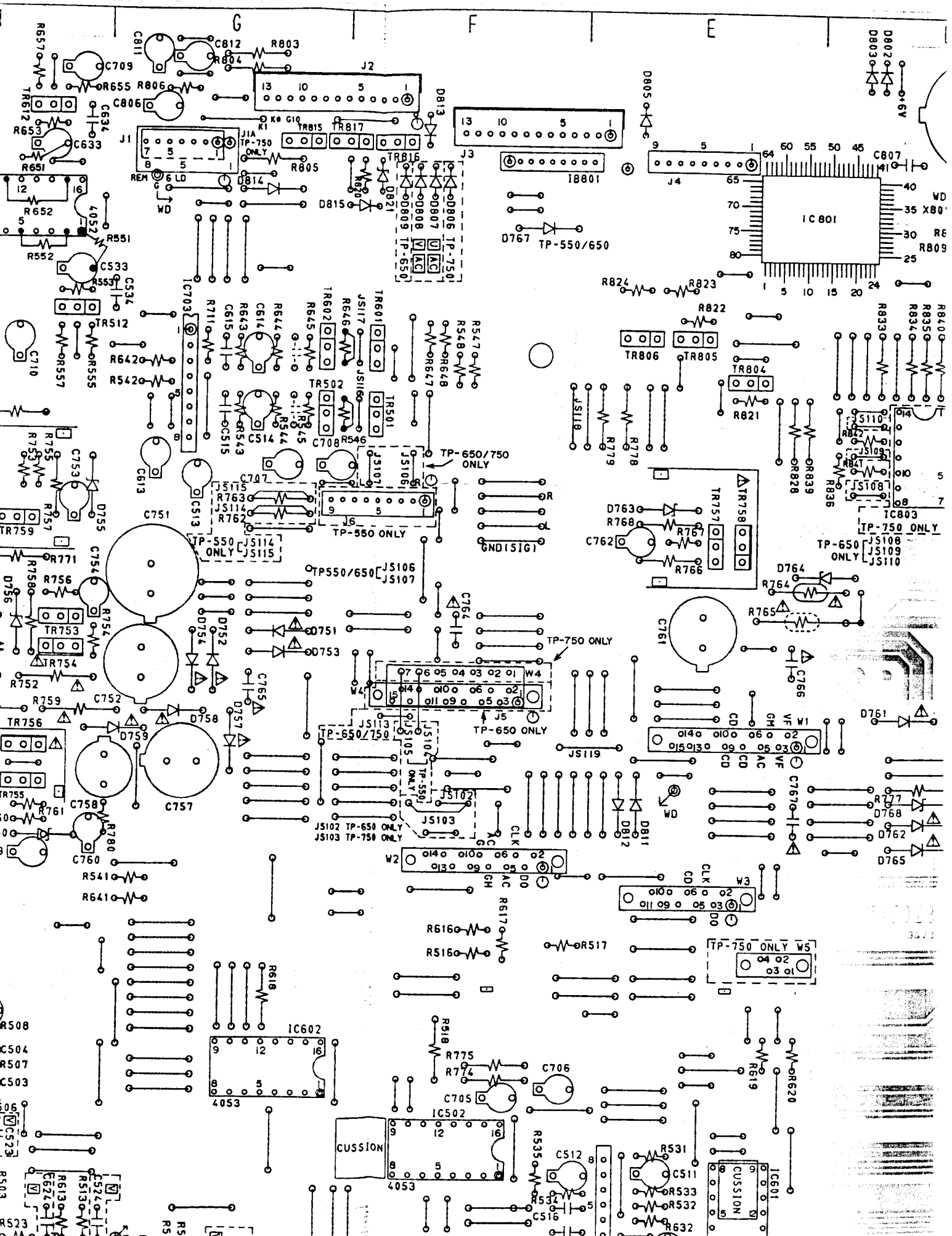

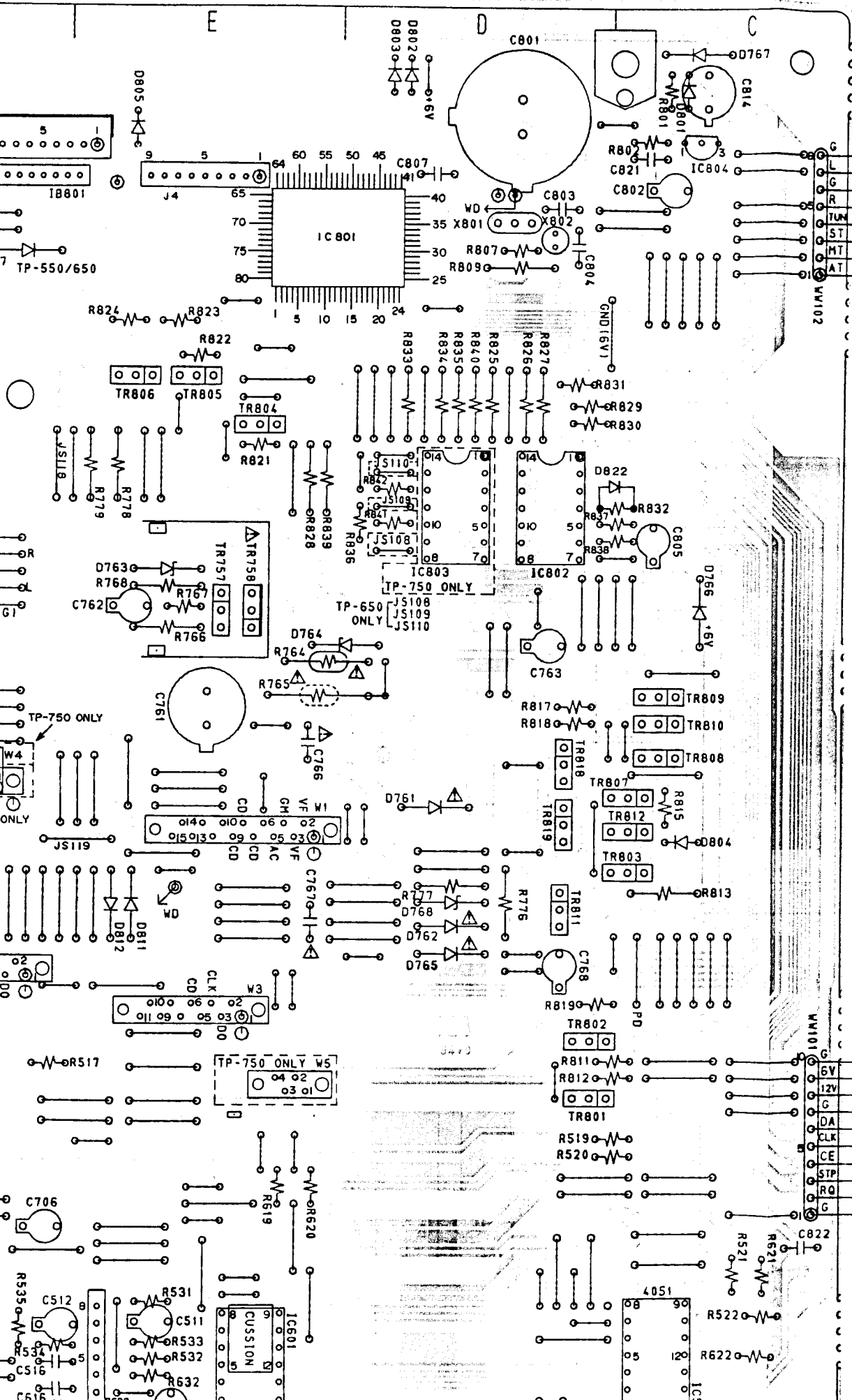

**PRINCIPA**

- ICs
- IC101 .....
- IC301 .....
- IC401 .....
- IC501 .....
- IC502 .....
- IC601 .....
- IC602 .....
- IC701 .....
- IC702 .....
- IC703 .....
- IC704 .....
- IC801 .....
- IC801A .....
- IC802 .....
- IC803 .....
- IC804 .....

**TRANSISTO**

- TR101 .....
- TR201 .....
- TR202 .....
- TR203 .....
- TR401 .....
- TR402 .....
- TR403 .....
- TR404 .....
- TR405 .....
- TR406 .....
- TR407 .....
- TR408 .....
- TR501 .....
- TR502 .....
- TR512 .....
- TR601 .....
- TR602 .....
- TR612 .....
- TR752 .....

NOTE : PARTS DIFFER  
REFER TO SCHE  
PARTS INFORMA

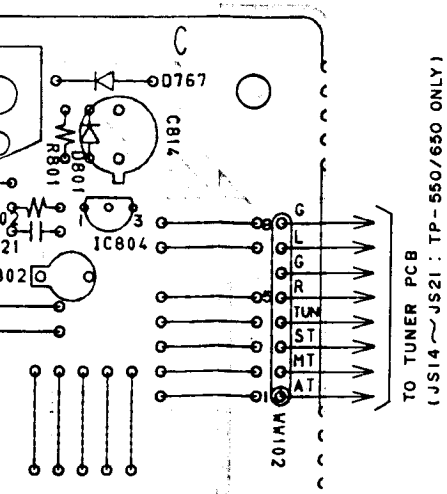

TO TUNER PCB  
(JS14 ~ JS21 : TP-550/650 ONLY)

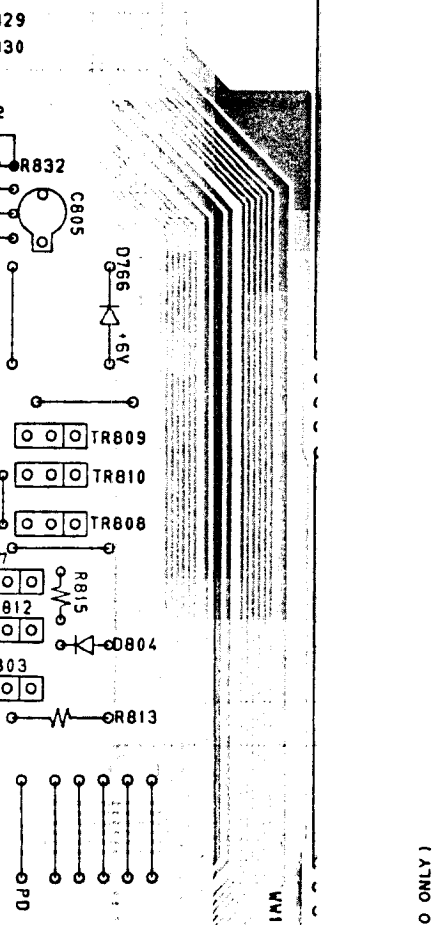

TO TUNER PCB  
(JS4 ~ JS13 : TP-550/650 ONLY)

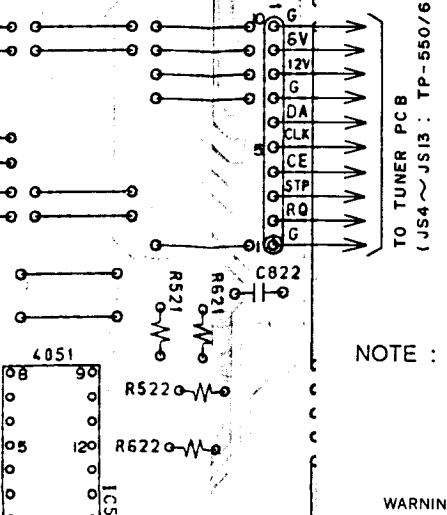

**PRINCIPAL PARTS LOCATION**

<b>ICs</b>		
IC101 .....	B2,3	TR753..... H3
IC301 .....	B1	TR754..... H3
IC401 .....	B4,5	TR755..... H4
IC501 .....	C5,6	TR756..... H4
IC502 .....	F5	TR757..... E3
IC601 .....	E5,6	TR758..... E3
IC602 .....	G5	TR759..... H3
IC701 .....	H5	TR760..... H3
IC702 .....	E5,6	TR761..... H4
IC703 .....	G2	TR801..... D5
IC704 .....	H1	TR802..... D4
IC801 .....	D,E1	TR803..... C4
IC801A .....	D,E1	TR804..... E2
IC802 .....	D2,3	TR805..... E2
IC803 .....	D2,3	TR806..... E2
IC804 .....	C1	TR807..... C3
<b>TRANSISTORS</b>		
TR101 .....	B3	TR808..... C3
TR201 .....	A3	TR809..... C3
TR202 .....	A4	TR810..... C3
TR203 .....	A3	TR811..... D4
TR401 .....	B5	TR812..... C4
TR402 .....	B5,6	TR815..... G1
TR403 .....	B4	TR816..... F1
TR404 .....	B4	TR817..... F,G1
TR405 .....	B2	TR818..... D3
TR406 .....	A4	TR819..... D3,4
TR407 .....	A4	
TR408 .....	B4	
TR501 .....	F2	
TR502 .....	G2	
TR512 .....	H2	
TR601 .....	F2	
TR602 .....	G2	
TR612 .....	H1	
TR752 .....	H2	
<b>CONNECTORS</b>		
J1,J1A .....	G1	
J2 .....	F,G1	
J3 .....	E,F1	
J4 .....	E1	
J5 .....	F3	
J6 .....	F,G3	
J11,11A,B,C .....	G,H6	
J101 .....	B3	

NOTE : PARTS DIFFER DEPENDING ON MODEL NUMBER.  
REFER TO SCHEMATIC DIAGRAMS FOR PERTAINING PARTS INFORMATION.

WARNING: Δ INDICATES SAFETY CRITICAL COMPONENTS FOR CONTINUED SAFETY.

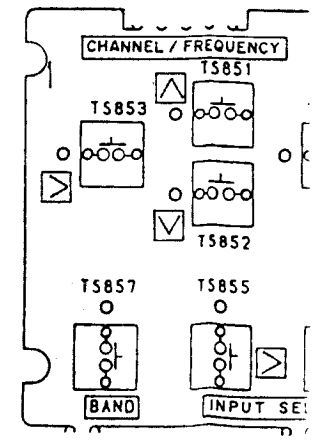
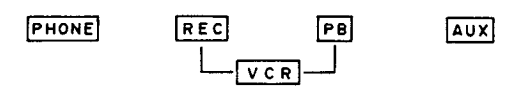
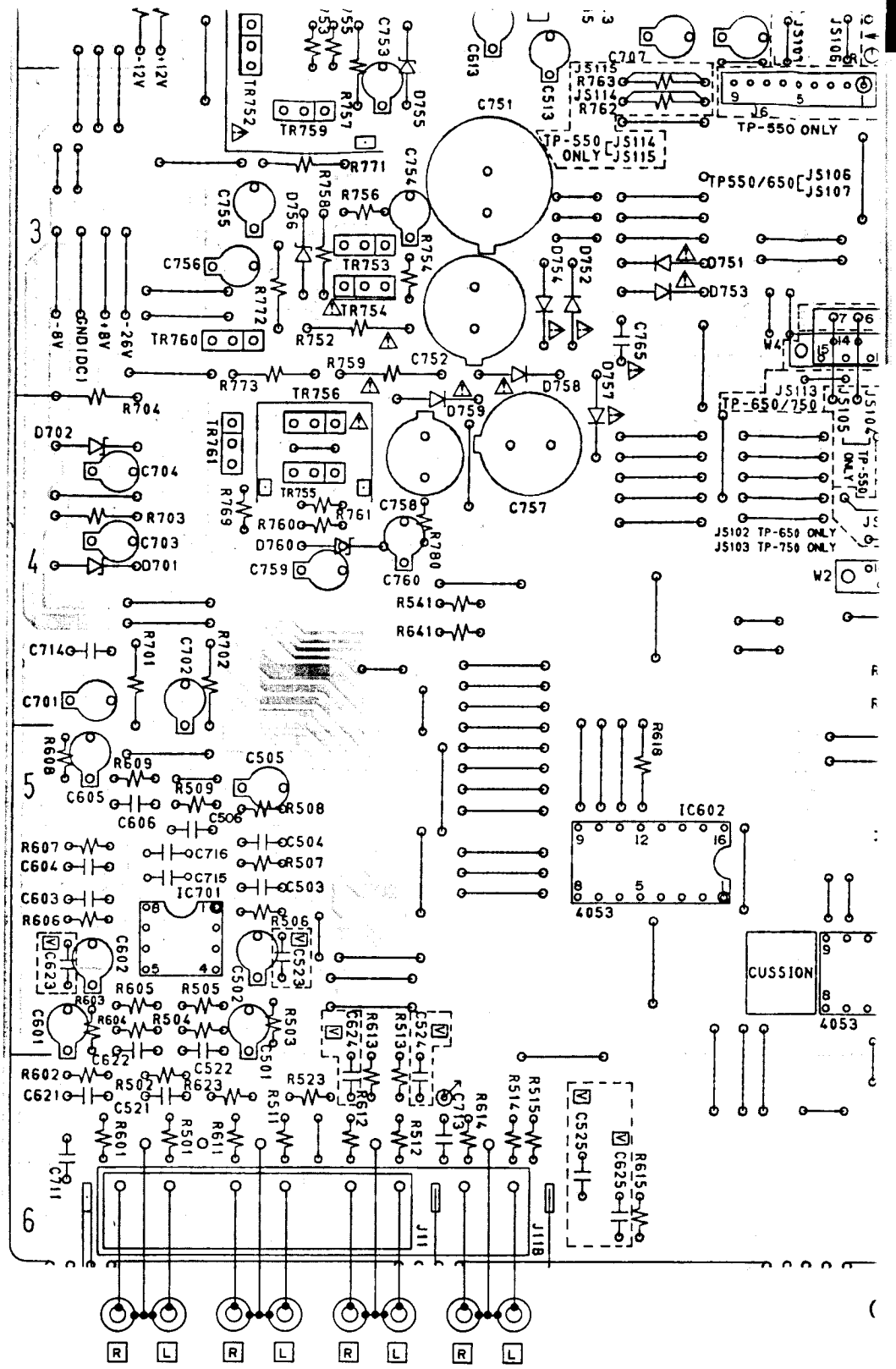



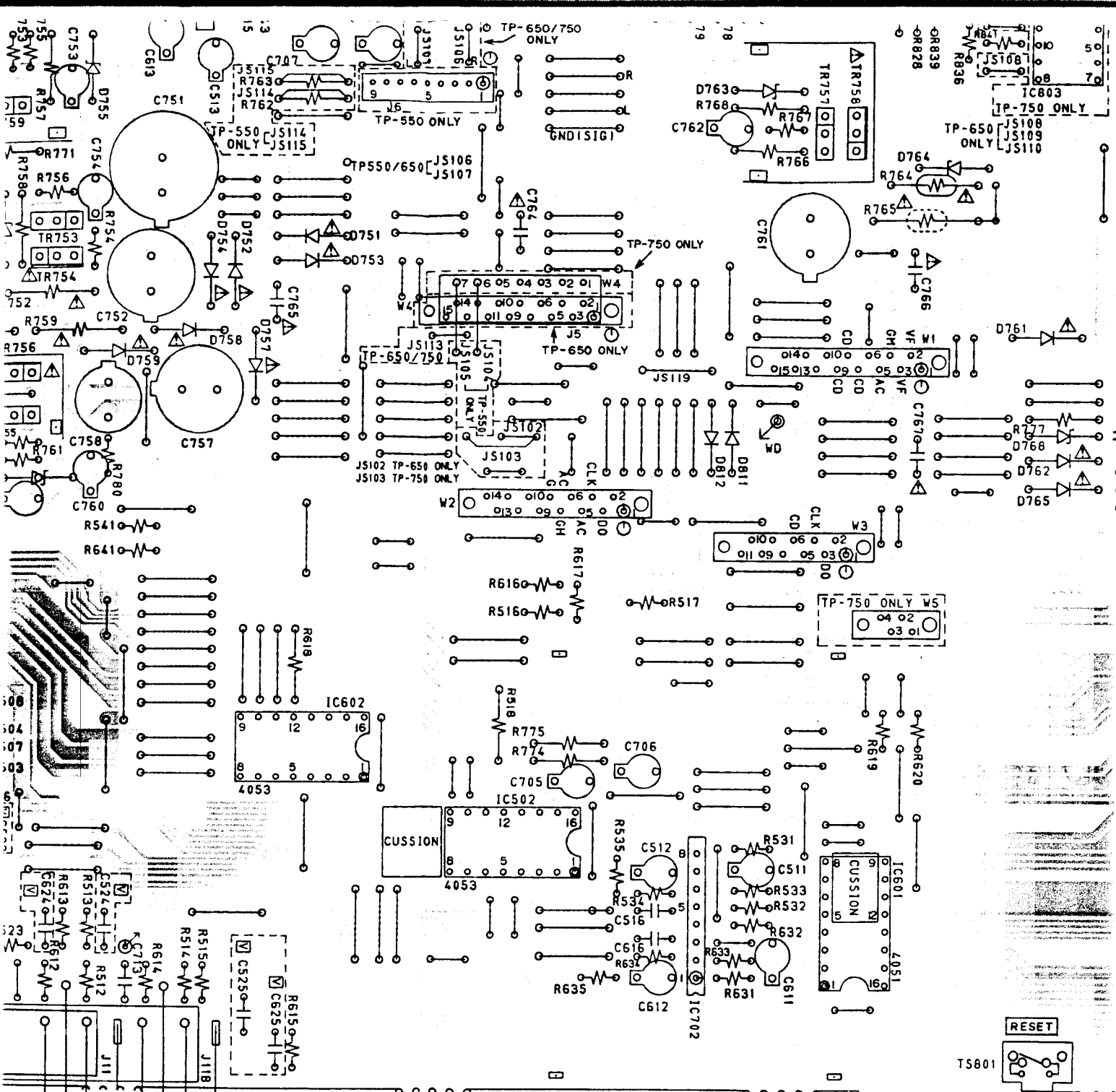

CONTROL PCB A6007A502B

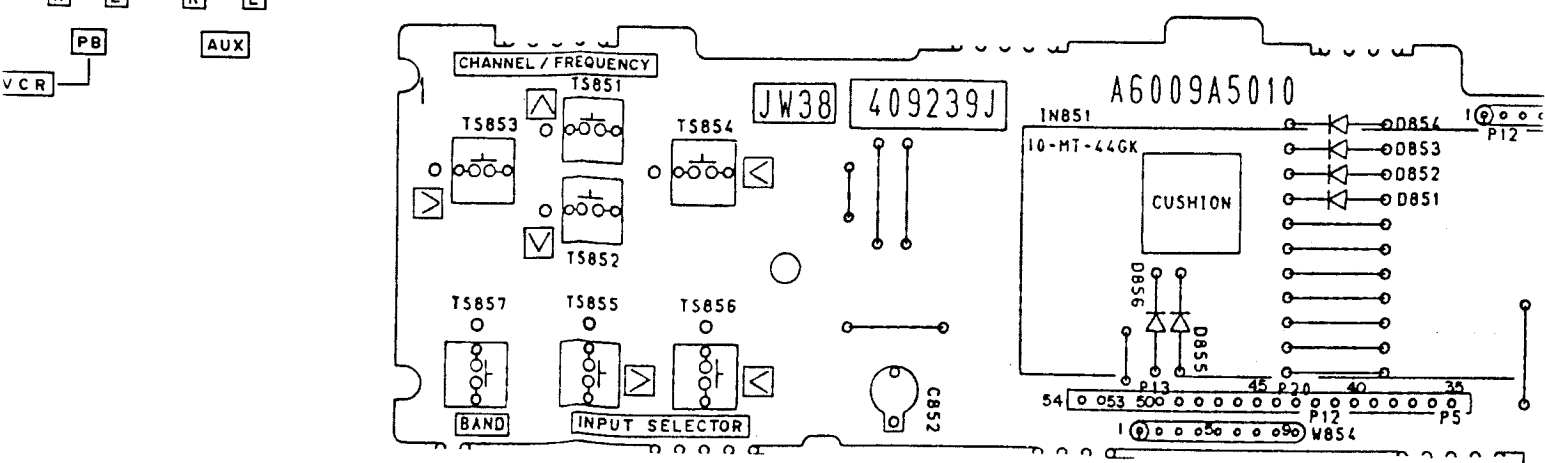

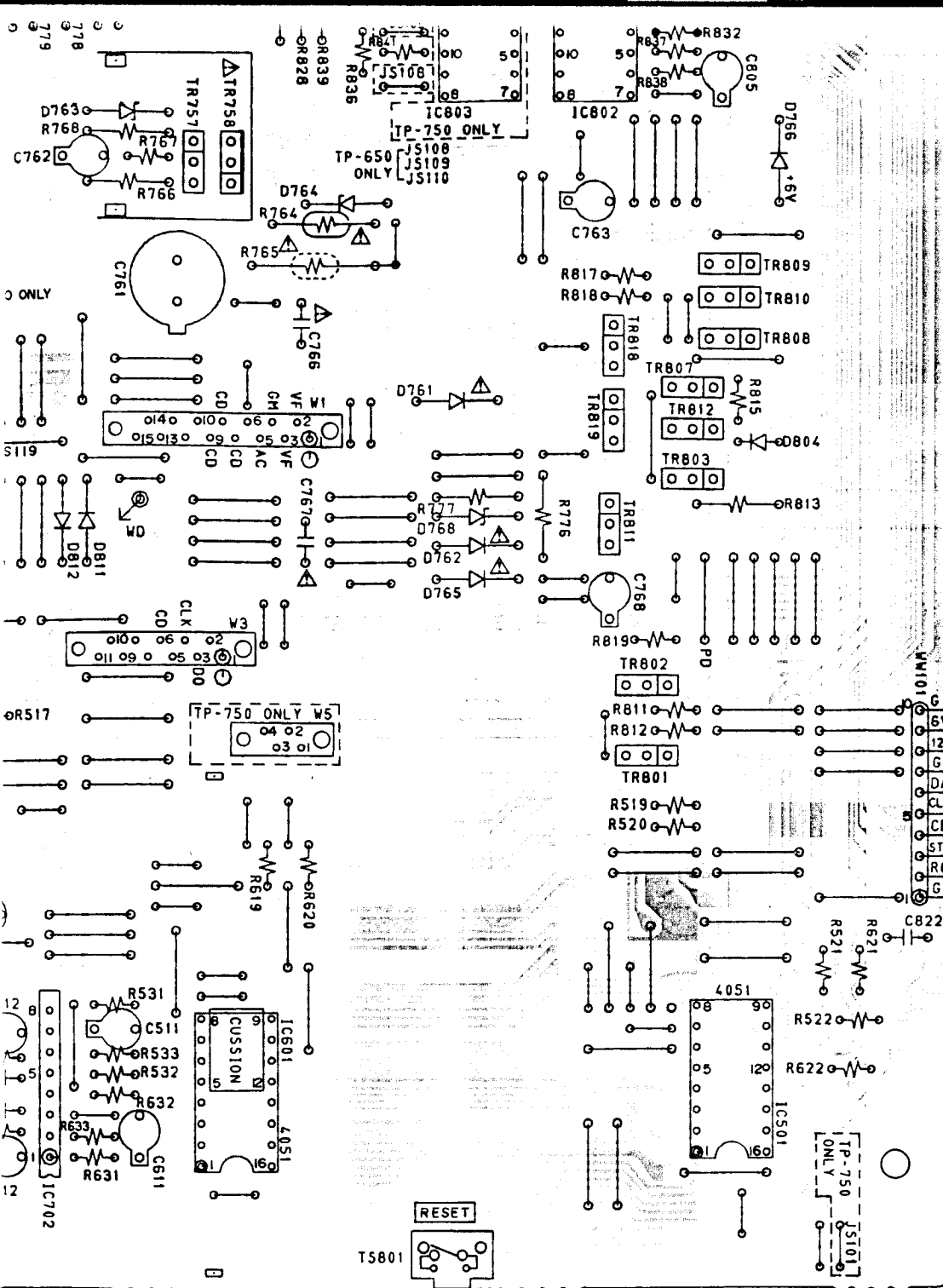

TR201	.....	A3
TR202	.....	A4
TR203	.....	A3
TR401	.....	B5
TR402	.....	B5,6
TR403	.....	B4
TR404	.....	B4
TR405	.....	B2
TR406	.....	A4
TR407	.....	A4
TR408	.....	B4
TR501	.....	F2
TR502	.....	G2
TR512	.....	H2
TR601	.....	F2
TR602	.....	G2
TR612	.....	H1
TR752	.....	H2

TO TUNER PCB  
(JS4~JS13 : TP-550/650 ONLY)

NOTE : PARTS DIFFER DEPEND REFER TO SCHEMATIC D PARTS INFORMATION.

WARNING: ⚠ INDICATES SAFETY CRITICAL CO REPLACE SAFETY CRITICAL COMPC RECOMMENDED PARTS  
 AVERTISSEMENT: ⚠ IL INDIQUE LES COMPOS POUR MAINTENIR LE DEGRÉ DE SÉ NE REMPLACER QUE DES PIÈCES F

A6007A502B

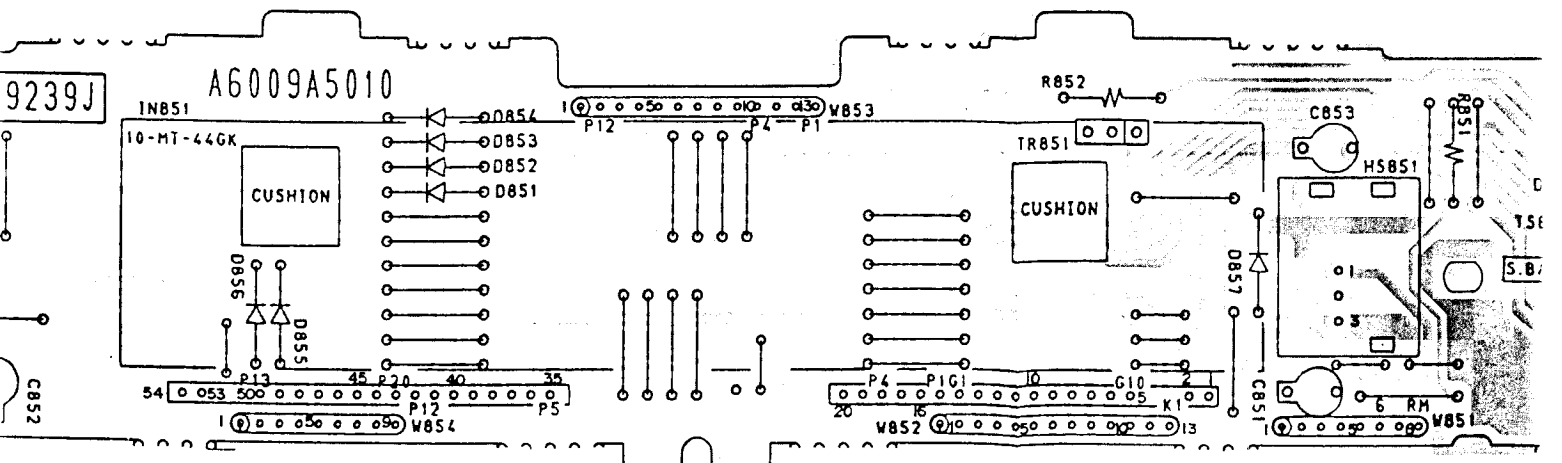

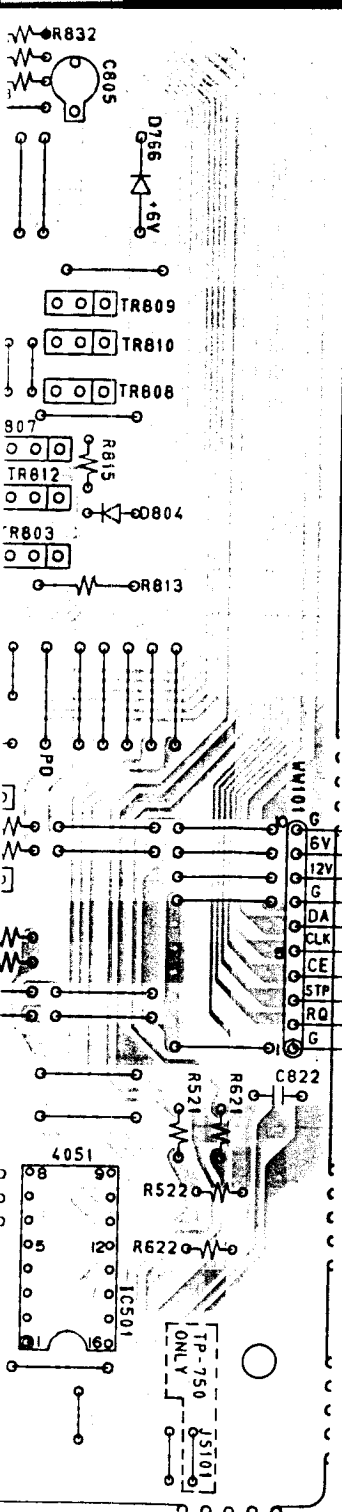

TR201	.....	A3	TR811	.....	D4
TR202	.....	A4	TR812	.....	C4
TR203	.....	A3	TR815	.....	G1
TR401	.....	B5	TR816	.....	F1
TR402	.....	B5,6	TR817	.....	F,G1
TR403	.....	B4	TR818	.....	D3
TR404	.....	B4	TR819	.....	D3,4
TR405	.....	B2			
TR406	.....	A4	<b>CONNECTORS</b>		
TR407	.....	A4	J1, J1A	.....	G1
TR408	.....	B4	J2	.....	F, G1
TR501	.....	F2	J3	.....	E, F1
TR502	.....	G2	J4	.....	E1
TR512	.....	H2	J5	.....	F3
TR601	.....	F2	J6	.....	F, G3
TR602	.....	G2	J11, J1A, B, C	.....	G, H6
TR612	.....	H1	J101	.....	B3
TR752	.....	H2			

TO TUNER PCB  
(JS4 ~ JS13 : TP-550/650 ONLY)

NOTE : PARTS DIFFER DEPENDING ON MODEL NUMBER.  
REFER TO SCHEMATIC DIAGRAMS FOR PERTAINING  
PARTS INFORMATION.

WARNING: **Δ** INDICATES SAFETY CRITICAL COMPONENTS FOR CONTINUED SAFETY.  
REPLACE SAFETY CRITICAL COMPONENTS ONLY WITH MANUFACTURER'S  
RECOMMENDED PARTS

AVERTISSEMENT: **Δ** IL INDIQUE LES COMPOSANTS CRITIQUES DE SÉCURITÉ.  
POUR MAINTENIR LE DEGRÉ DE SÉCURITÉ DE L'APPAREIL,  
NE REMPLACER QUE DES PIÈCES RECOMMANDÉES PAR LE FABRICANT

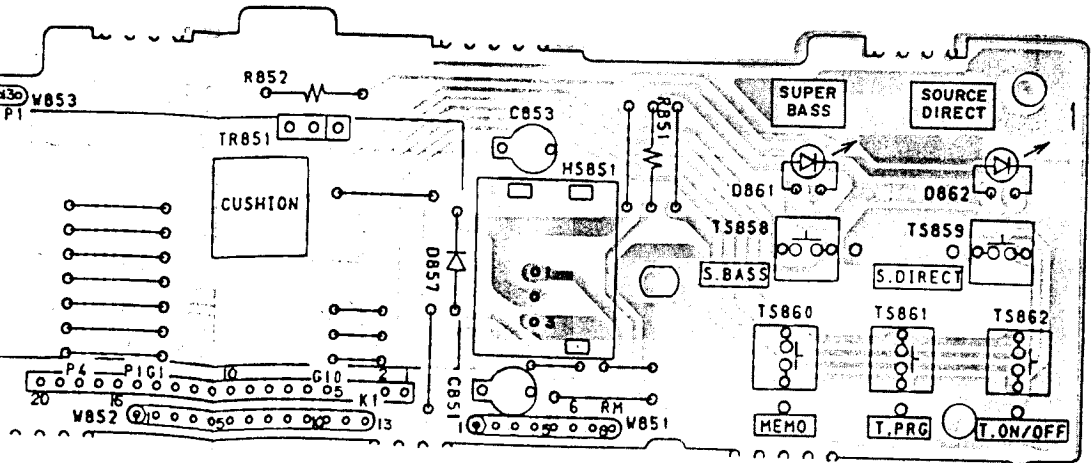

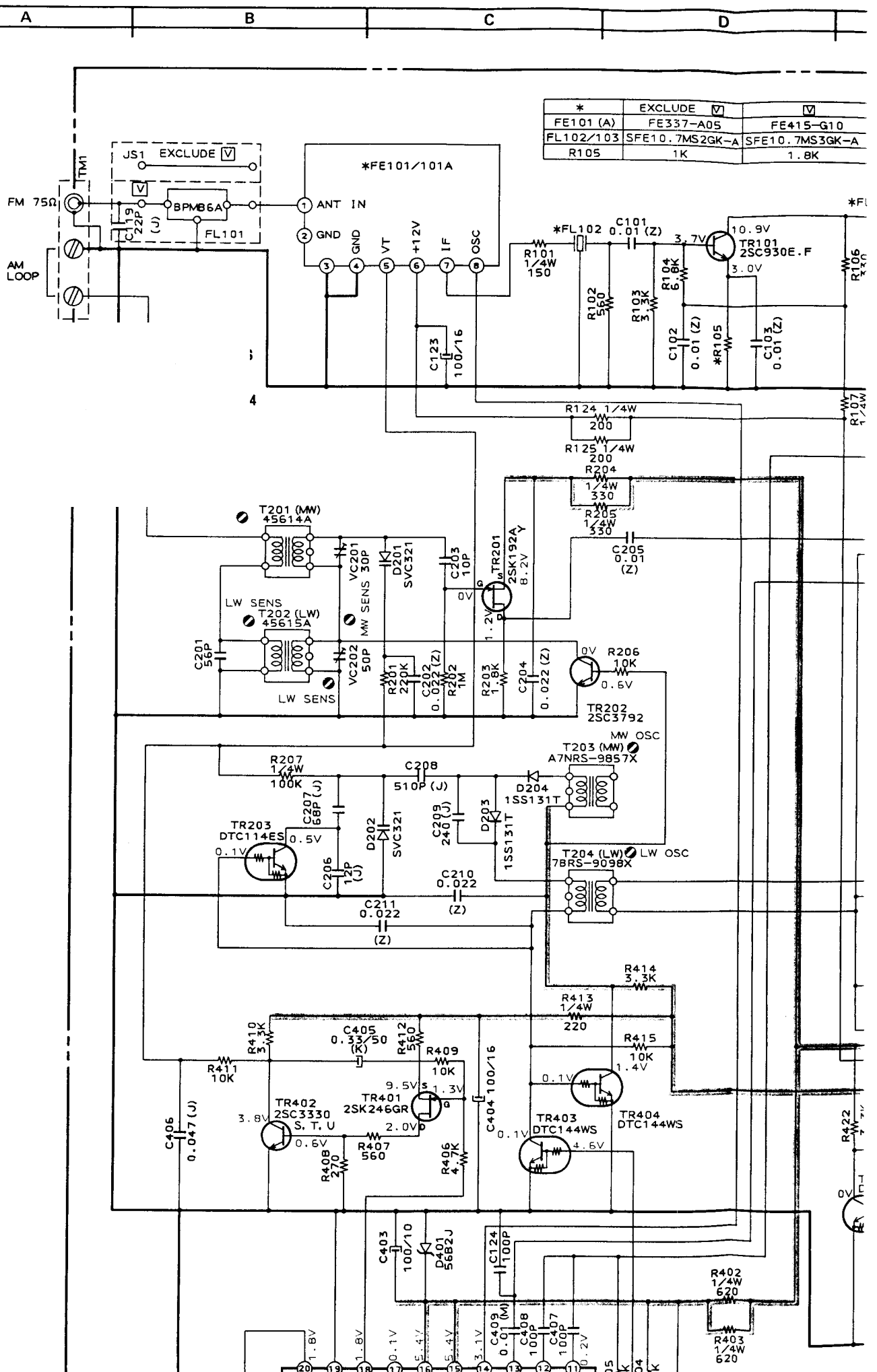

*	EXCLUDE	<input checked="" type="checkbox"/>	<input checked="" type="checkbox"/>
FE101 (A)	FE337-A05	<input checked="" type="checkbox"/>	FE415-G10
FL102/103	SFE10.7MS2GK-A	<input checked="" type="checkbox"/>	SFE10.7MS3GK-A
R105	1K	<input checked="" type="checkbox"/>	1.8K

*	EXCLUDE	
FE101 (A)	FE337-A05	FE415-G10
FL102/103	SFE10.7MS2GK-A	SFE10.7MS3GK-A
R105	1K	1.8K

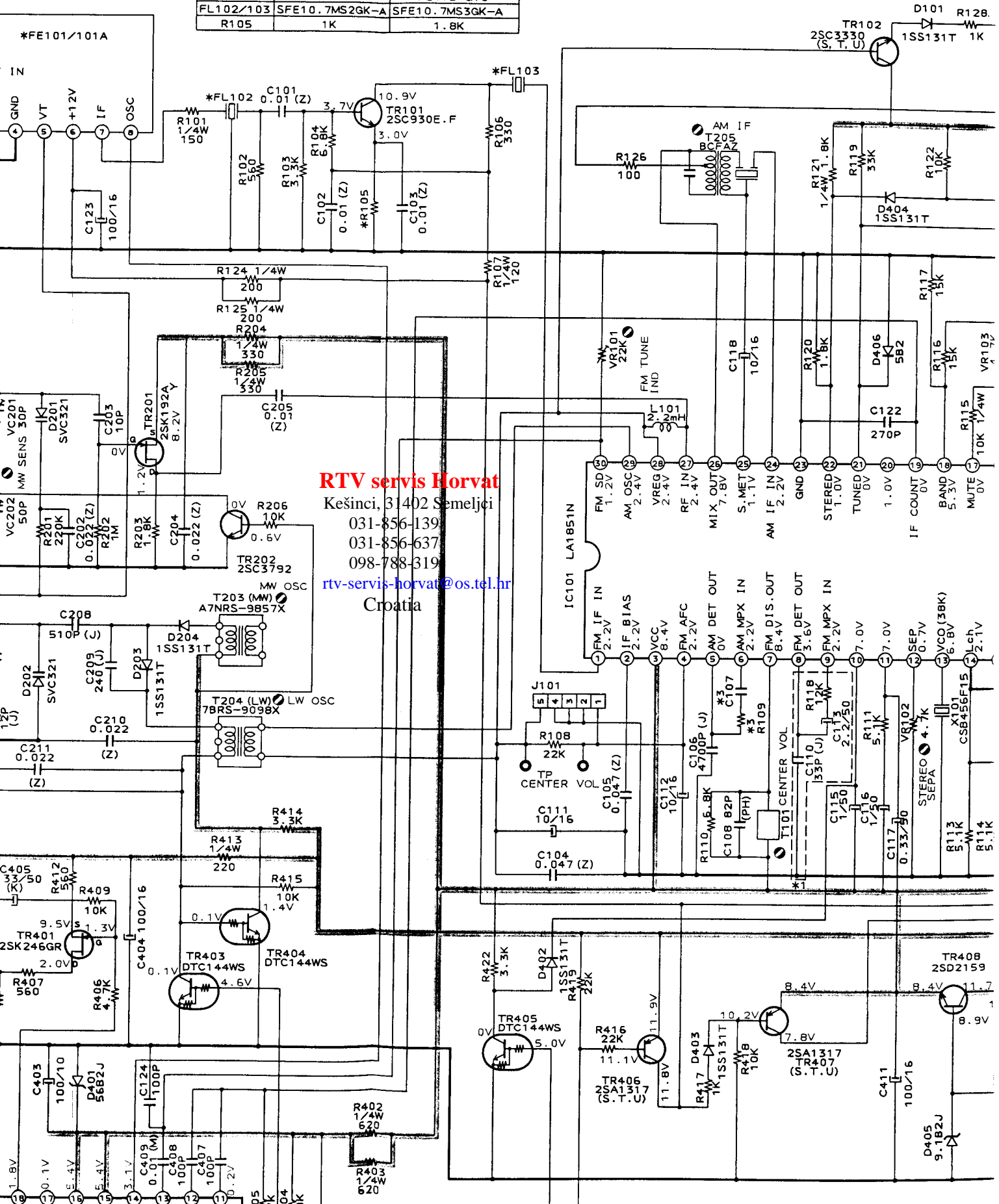

**RTV servis Horvat**

Kešinci, 31402 Semeljci

031-856-139

031-856-637

098-788-319

[rtv-servis-horvat@os.tel.hr](mailto:rtv-servis-horvat@os.tel.hr)

Croatia

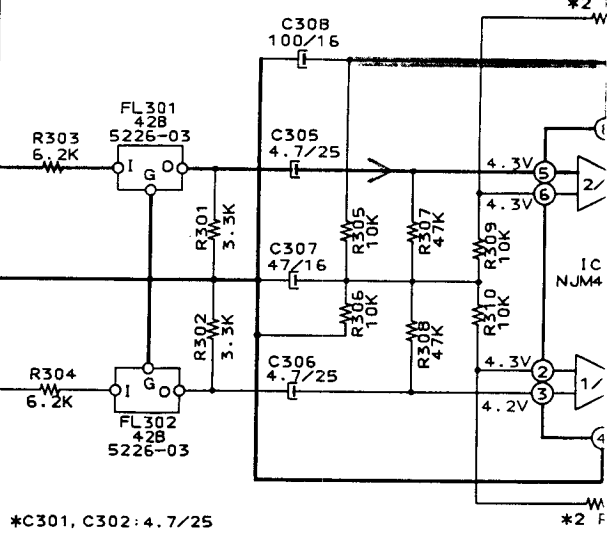
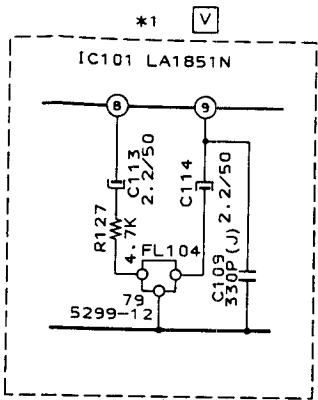
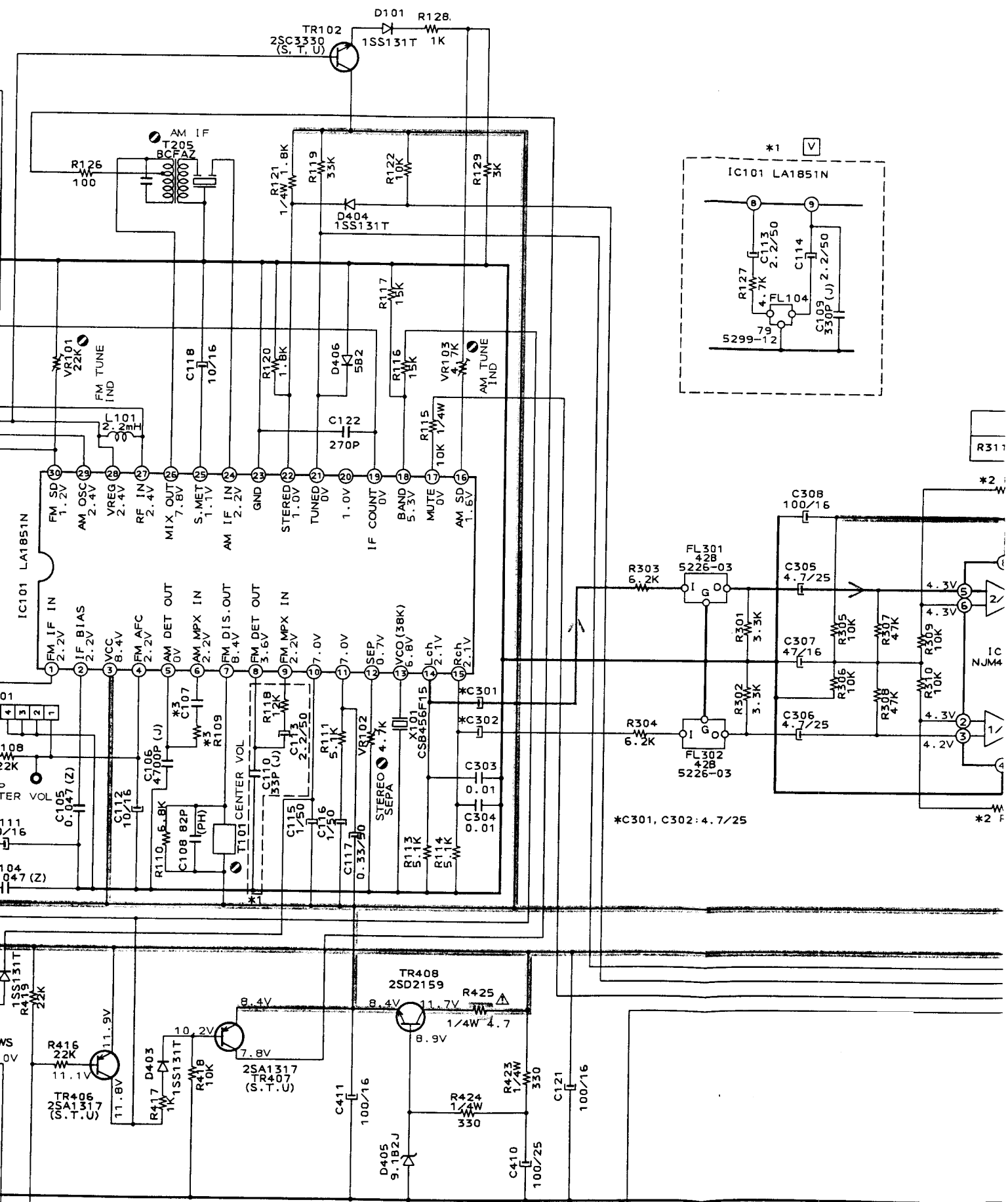

R311

\*2

IC NJM4

\*2 F

H

I

J

K

1

2

3

4

5

6

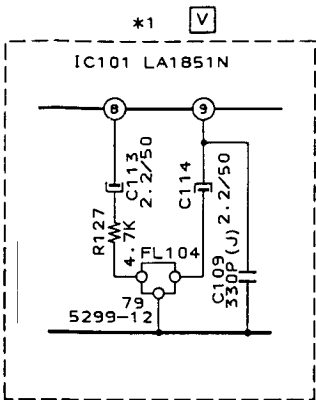

*2	EXCLUDE	
R311, R312	7.5K	20K

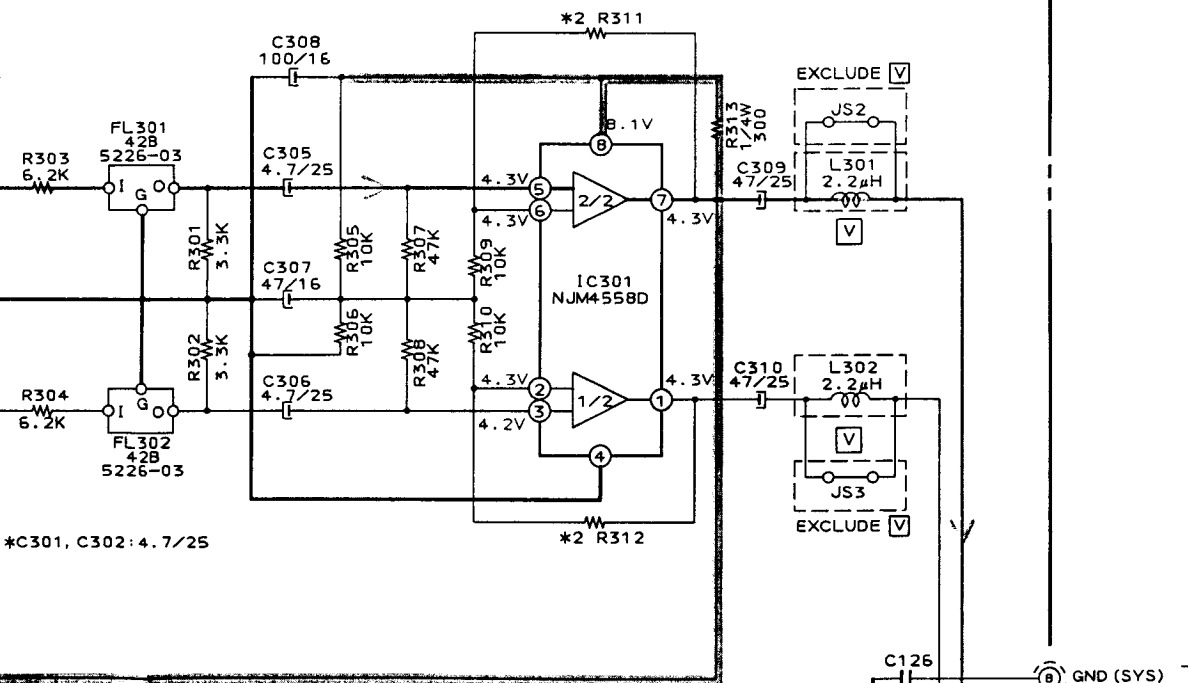

\*C301, C302: 4.7/25

### RTV servis Horvat

Kešinci, 31402 Semeljci  
 031-856-139  
 031-856-637  
 098-788-319

[rtv-servis-horvat@os.tel.hr](mailto:rtv-servis-horvat@os.tel.hr)  
 Croatia

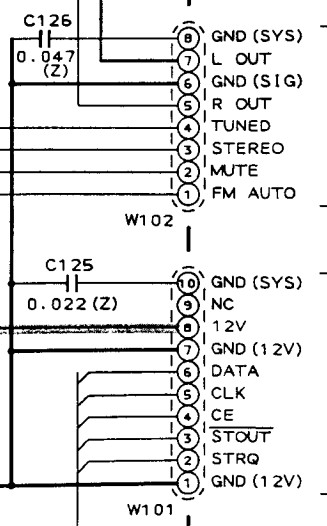

TO CONTROL PCB WW102

TO CONTROL PCB WW101

3

4

5

6

7

8

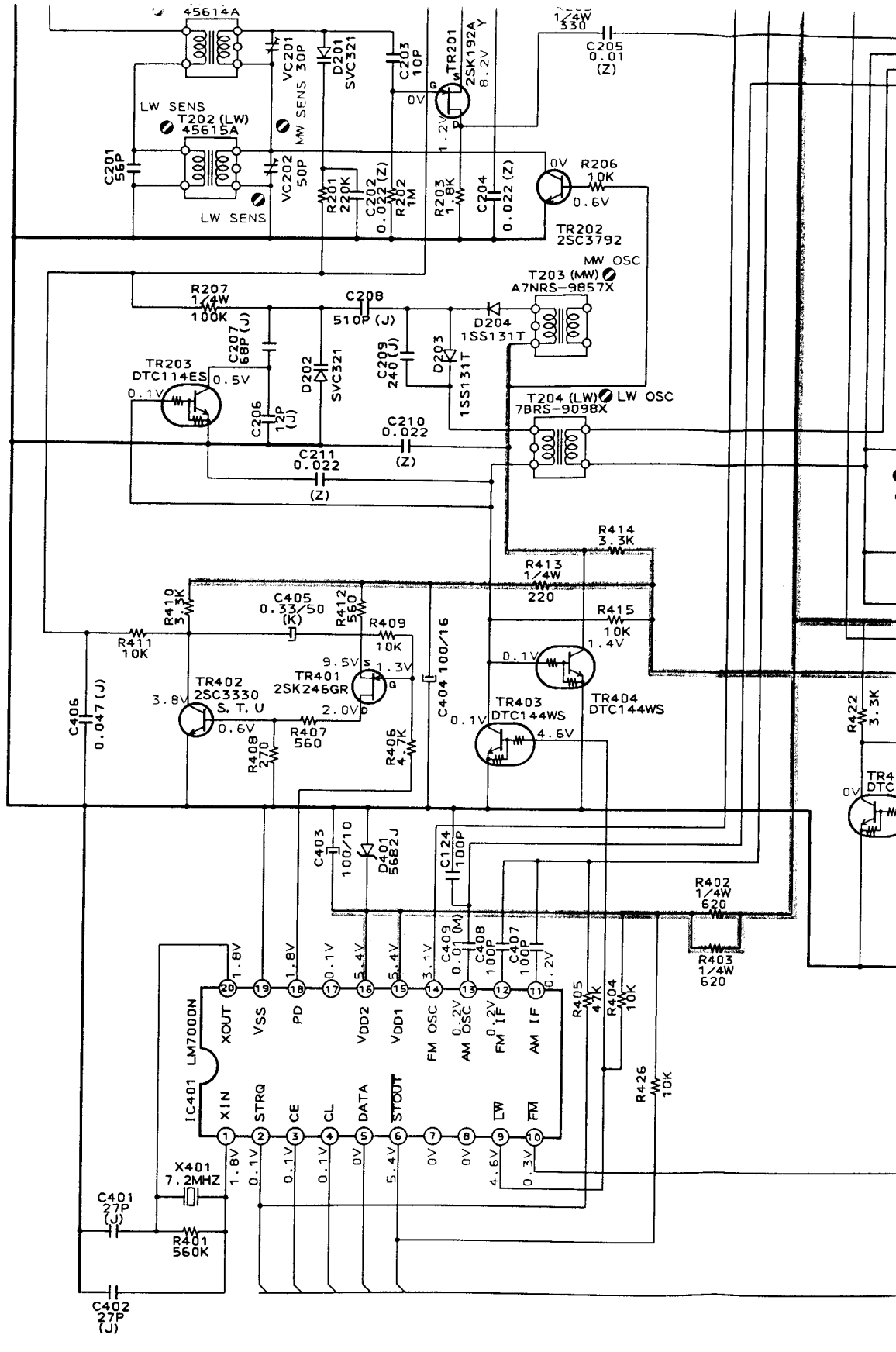

TUNER PCB A6007A502A

— B (POWER SUPPLY) L



— AUDIO SIGNAL LIN

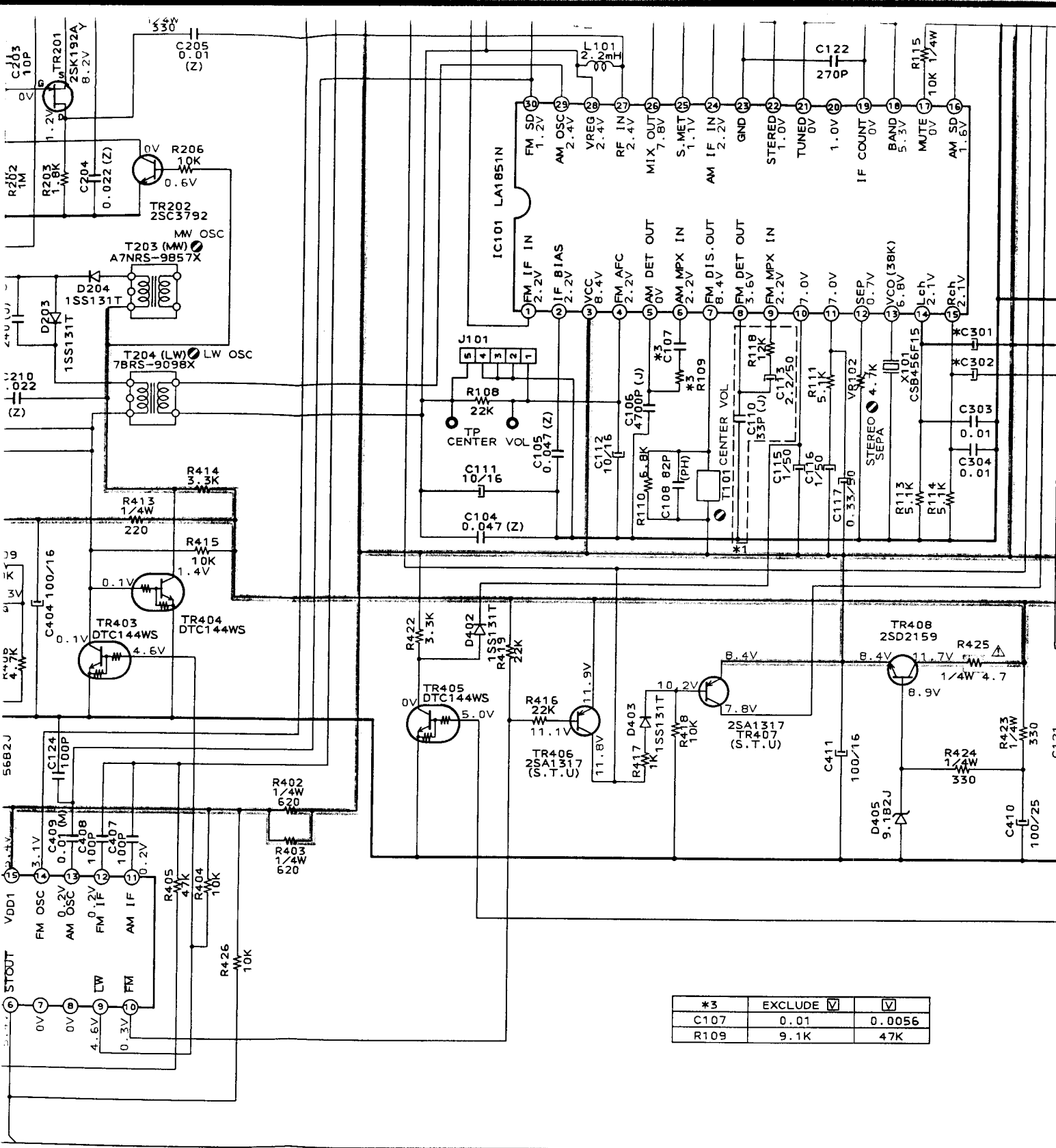







*3	EXCLUDE	<input checked="" type="checkbox"/>	<input checked="" type="checkbox"/>
C107	0.01		0.0056
R109	9.1K		47K

5007A502A

 B (POWER SUPPLY) LINE  
 AUDIO SIGNAL LINE (L-CH)

WARNING:  AND  INDICATE SAFETY CRITICAL COMPONENTS FOR CONTINUED SAFETY. REPLACE SAFETY CRITICAL COMPONENTS ONLY WITH MANUFACTURER'S RECOMMENDED PARTS  
 AVERTISSEMENT:  ET  ILS INDIQUENT LES COMPOSANTS CRITIQUES DE SÉCURITÉ. POUR MAINTENIR LE DEGRÉ DE SÉCURITÉ DE L'APPAREIL, NE REMPLACER QUE DES PIÈCES RECOMMANDÉES PAR LE FABRICANT

NOTE: UNLESS ALL RE: ALL CAI: ALL ELI: INDICA: DURING

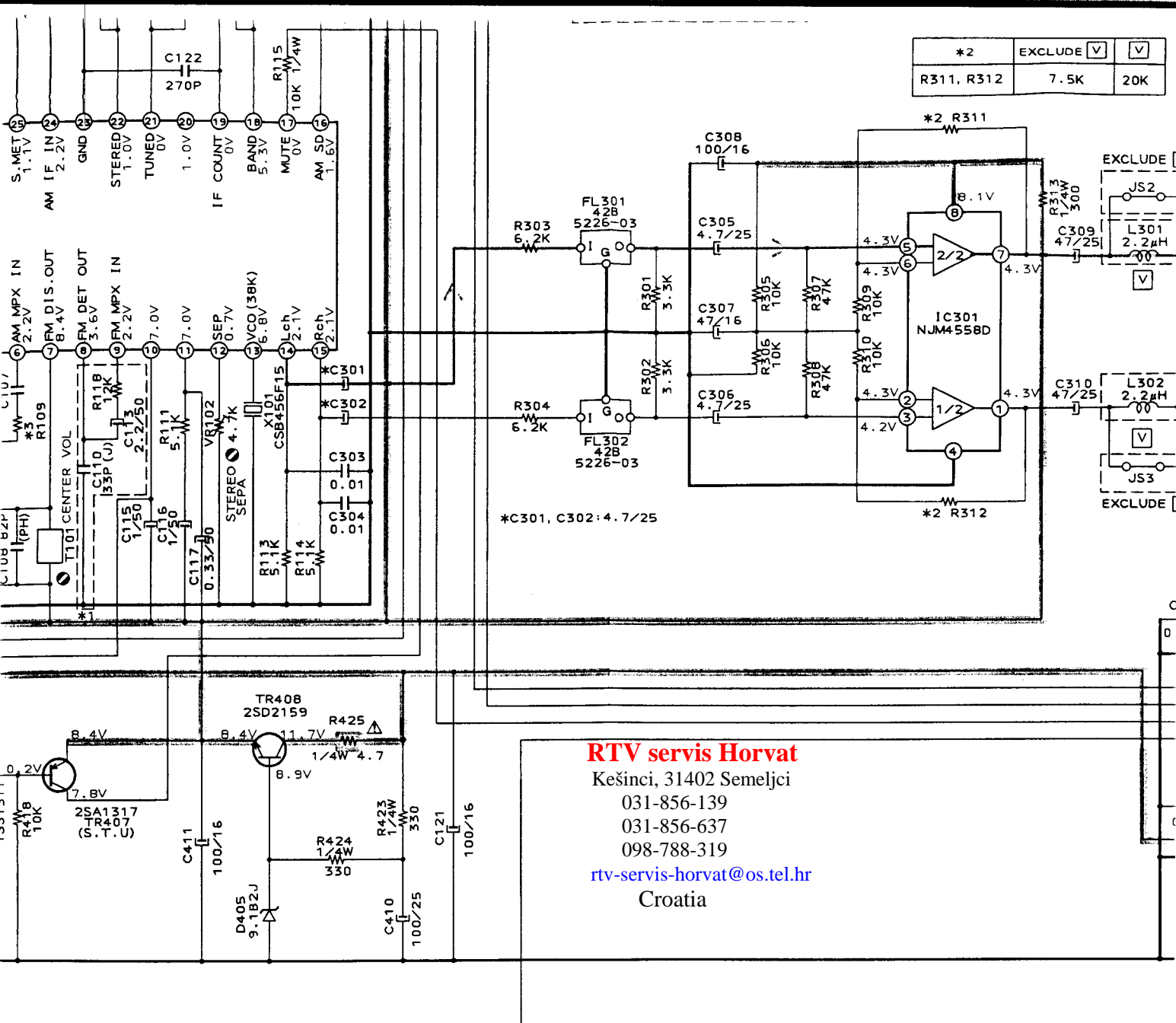

*2	EXCLUDE	<input checked="" type="checkbox"/>	<input checked="" type="checkbox"/>
R311, R312		7.5K	20K

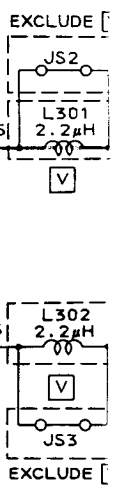

\*C301, C302: 4.7/25

\*2 R312

**RTV servis Horvat**

Kešinci, 31402 Semeljci  
 031-856-139  
 031-856-637  
 098-788-319  
[rtv-servis-horvat@os.tel.hr](mailto:rtv-servis-horvat@os.tel.hr)  
 Croatia

*3	EXCLUDE	<input checked="" type="checkbox"/>	<input checked="" type="checkbox"/>
C107		0.01	0.0056
R109		9.1K	47K

INDICATE SAFETY CRITICAL COMPONENTS FOR CONTINUED SAFETY.  
 REPLACE SAFETY CRITICAL COMPONENTS ONLY WITH MANUFACTURER'S RECOMMENDED PARTS.  
 ET ILS INDIQUENT LES POSTES CRITIQUES DE SÉCURITÉ.  
 POUR MAINTENIR LE DEGRÉ DE SÉCURITÉ DE L'APPAREIL, NE REMPLACER QUE DES PIÈCES RECOMMANDÉES PAR LE FABRICANT

NOTE:  
 UNLESS OTHERWISE SPECIFIED  
 ALL RESISTORS IN OHMS  
 ALL CAPACITORS IN μF (P=PF)  
 ALL ELECTROLYTIC CAPACITORS IN μF/W

INDICATED VOLTAGES WERE MEASURED DURING FM STEREO MODE.

TP-7  
 TUNE  
 SCHE  
 N

*2	EXCLUDE <input type="checkbox"/>	<input type="checkbox"/>
R311, R312	7.5K	20K

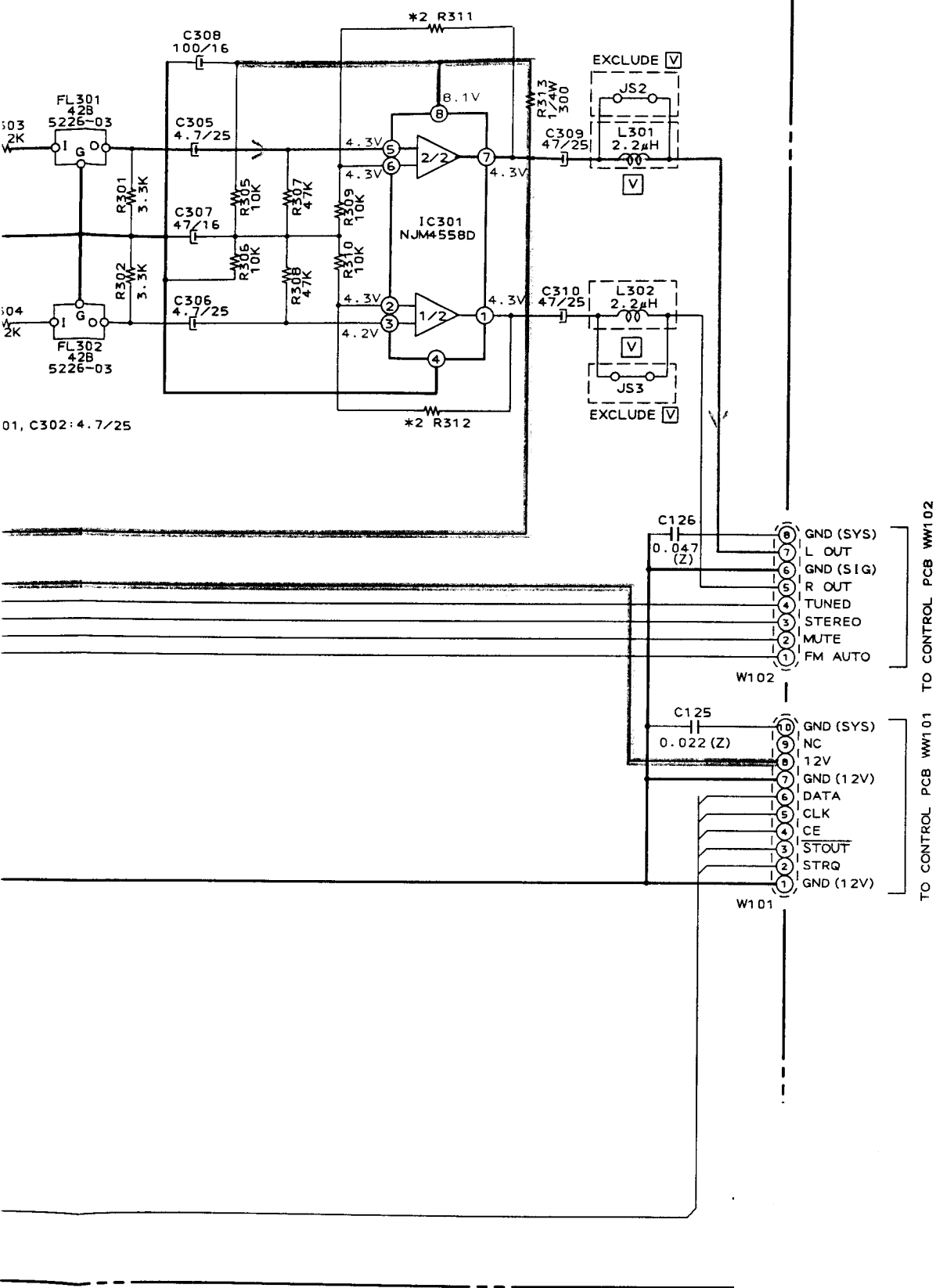

01, C302: 4.7/25

ALL DIMENSIONS SPECIFIED  
RESISTORS IN OHMS  
CAPACITORS IN µF (P-PF)  
RESISTORS IN µF/W

ALL DIMENSIONS WERE MEASURED  
IN THIS MODE.

TP-750  
TUNER  
SCHEMATIC DIAGRAM  
No. 8-2 A600902M  
A1

3  
4  
5  
6  
7  
8

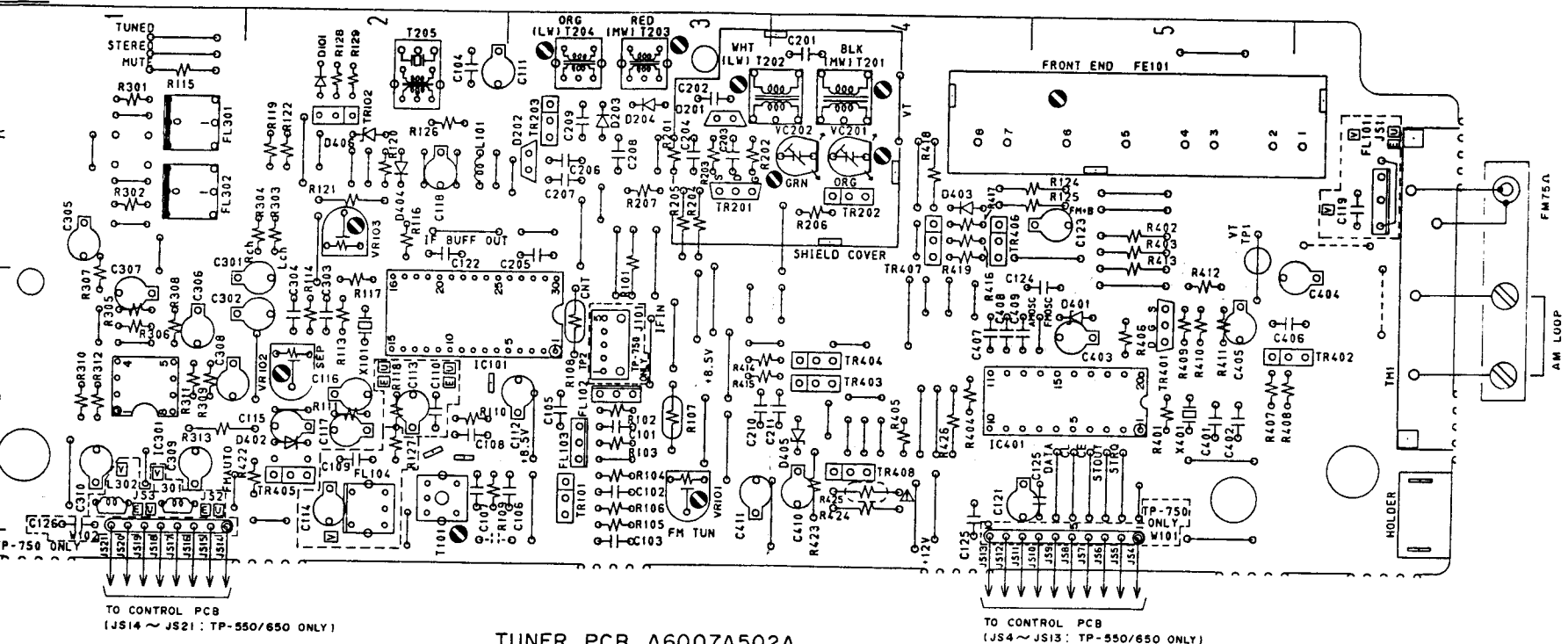

TO CONTROL PCB  
(JS14 ~ JS21: TP-550/650 ONLY)

TUNER PCB A6007A502A

TO CONTROL PCB  
(JS4 ~ JS13: TP-550/650 ONLY)

WARNING:  $\Delta$  INDICATES SAFETY CRITICAL COMPONENTS FOR CONTINUED SAFETY  
REPLACE SAFETY CRITICAL COMPONENTS ONLY WITH MANUFACTURER'S  
RECOMMENDED PARTS

VERTISSEMENT:  $\Delta$  IL INDIQUE LES COMPOSANTS CRITIQUES DE SÉCURITÉ  
POUR MAINTENIR LE DEGRÉ DE SÉCURITÉ DE L'APPAREIL.  
NE REMPLACER QUE DES PIÈCES RECOMMANDÉES PAR LE FABRICANT

NOTE : PARTS DIFFER DEPENDING ON MODEL NUMBER.  
REFER TO SCHEMATIC DIAGRAMS FOR PERTAINING  
PARTS INFORMATION.

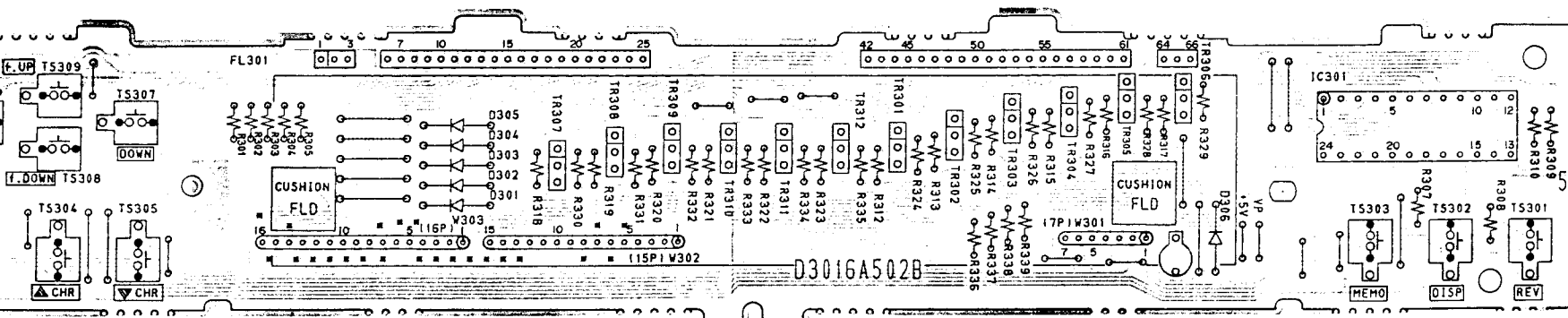

FRONT PCB D3016A502B

1

2

3

4

5

6

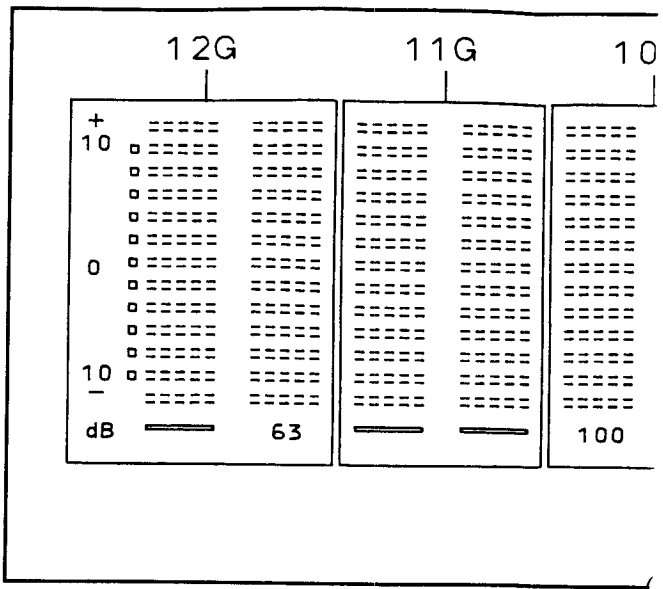

FL301  
BJO48GK

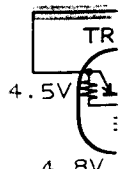
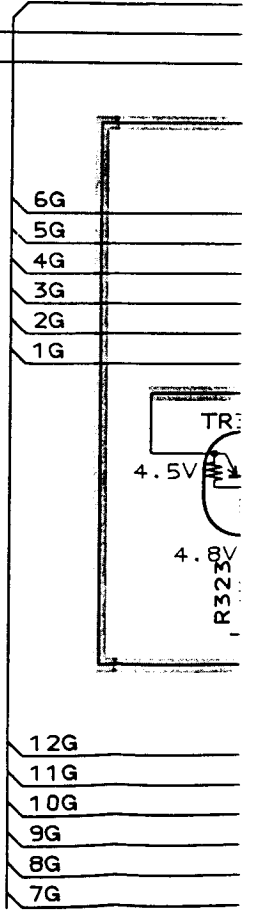
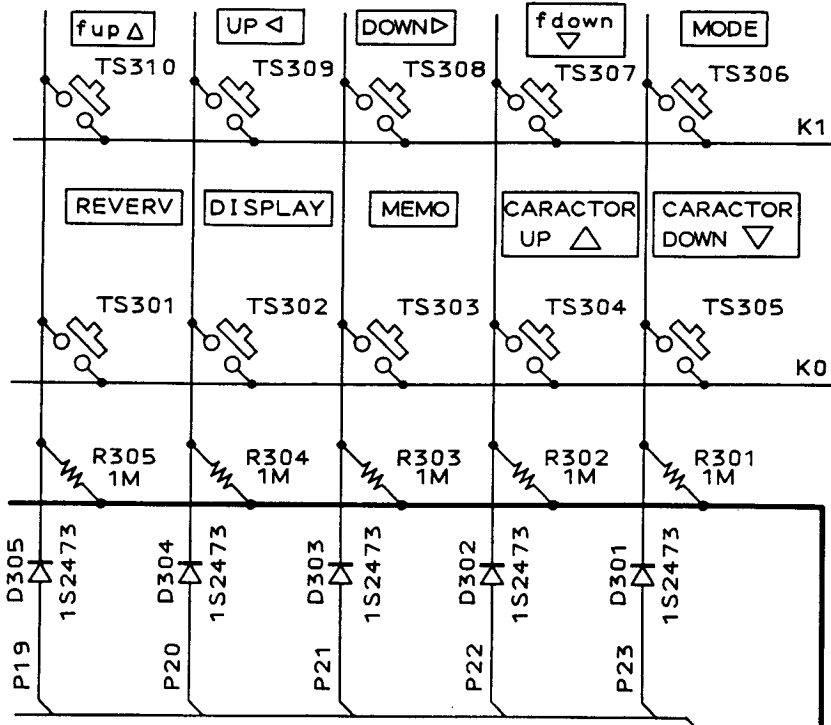

C

D

E

F

12G

11G

10G

9G

8G

7G

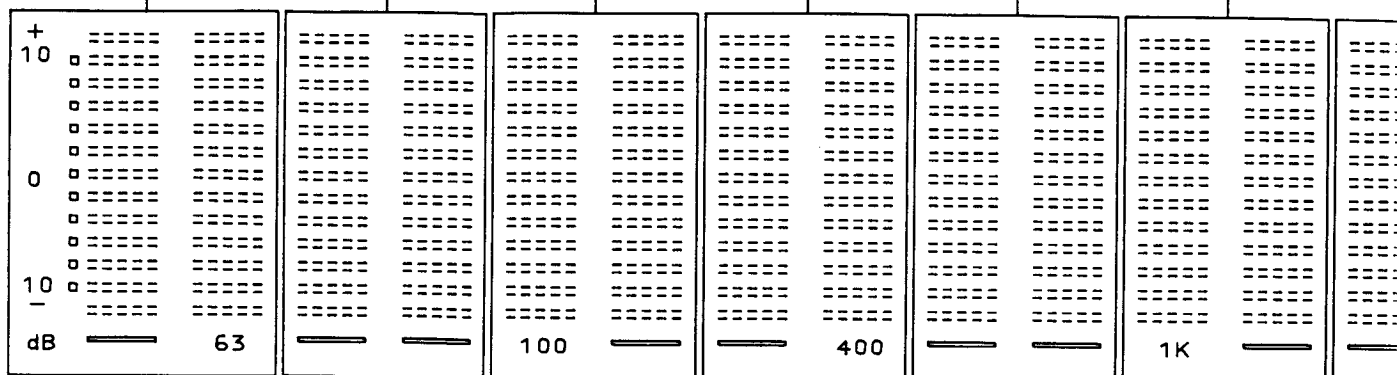

FL301  
BJ048GK

FL  
1 2 3

12G  
61  
11G  
60  
10G  
59  
9G  
58  
8G  
57  
7G  
56  
6G  
55  
5G  
54  
4G  
53  
3G  
52  
2G  
51  
1G  
50

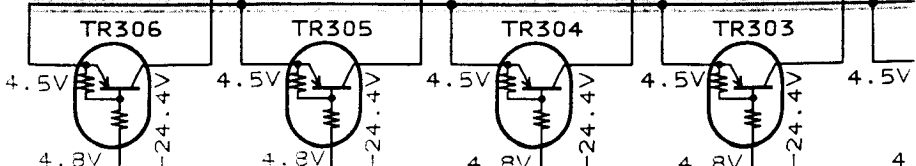
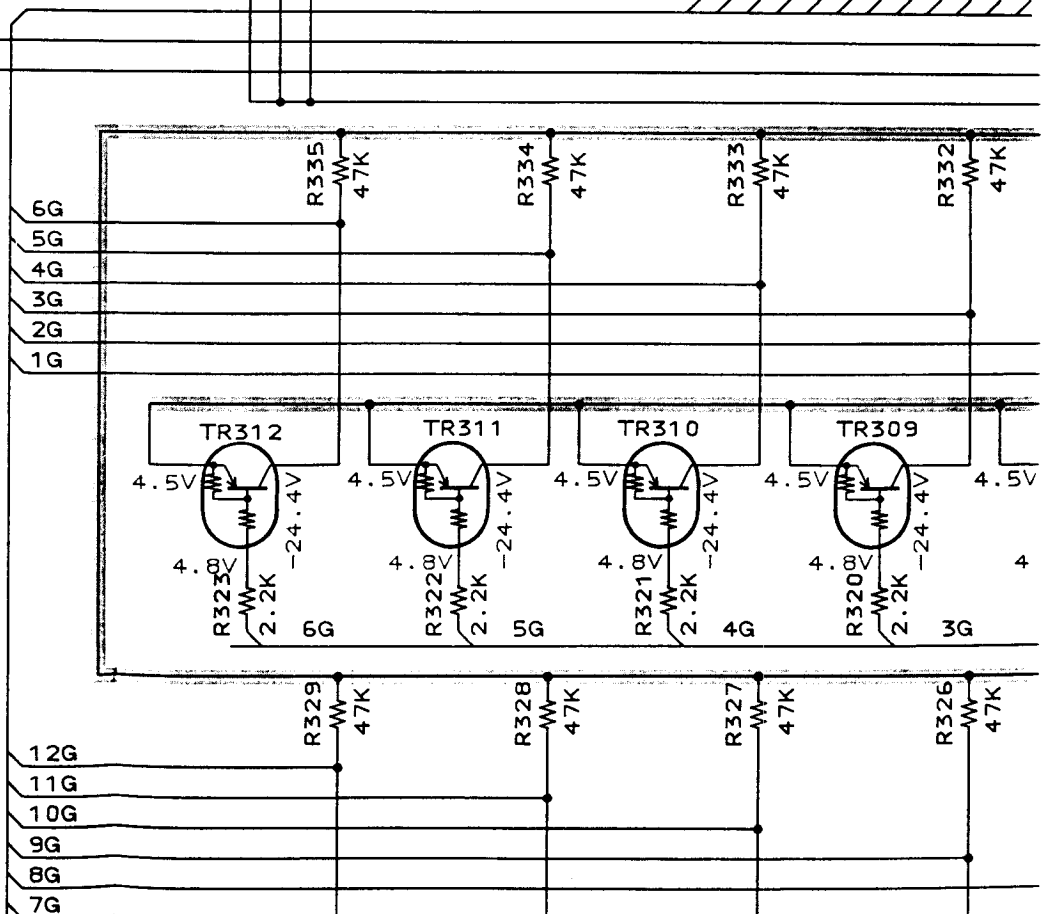
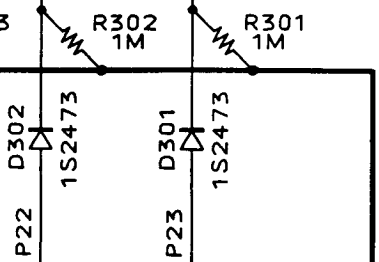
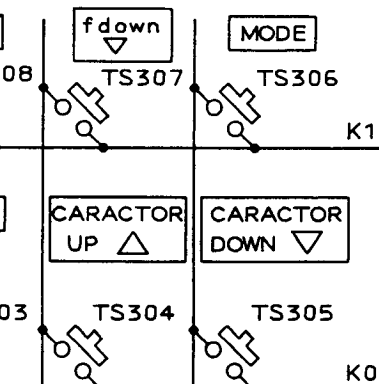

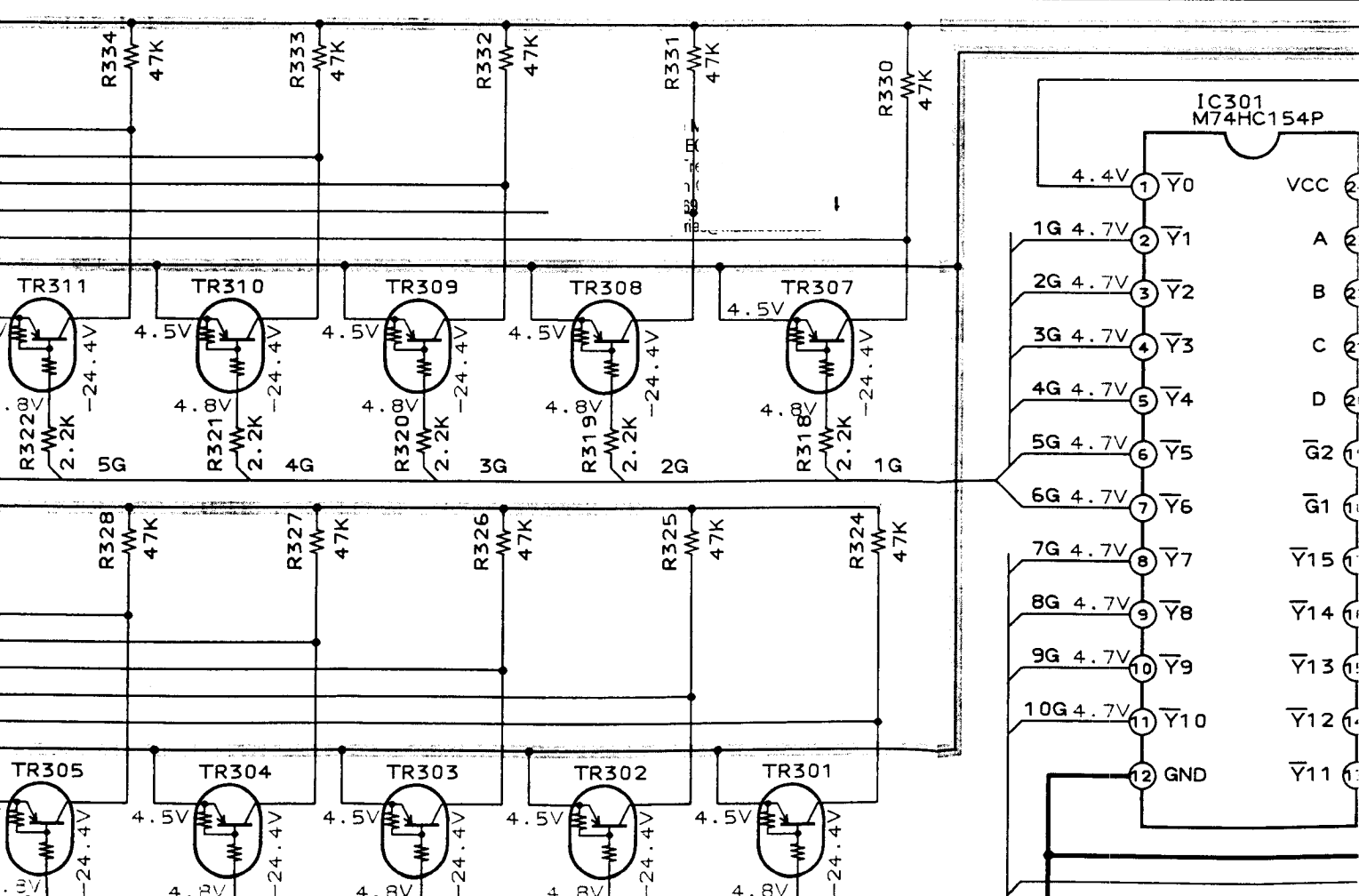
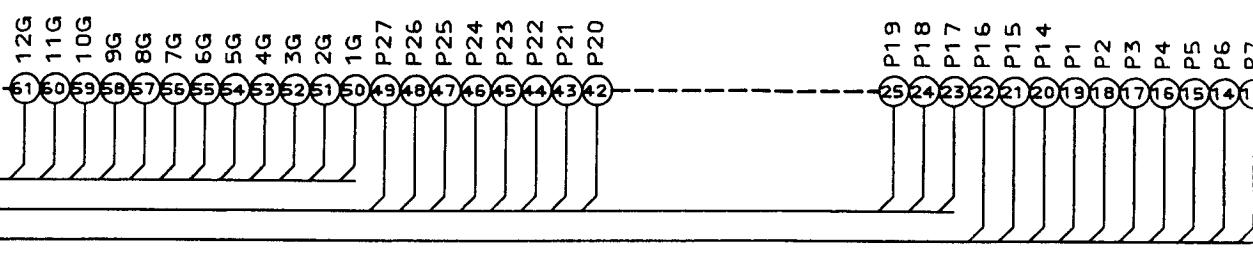
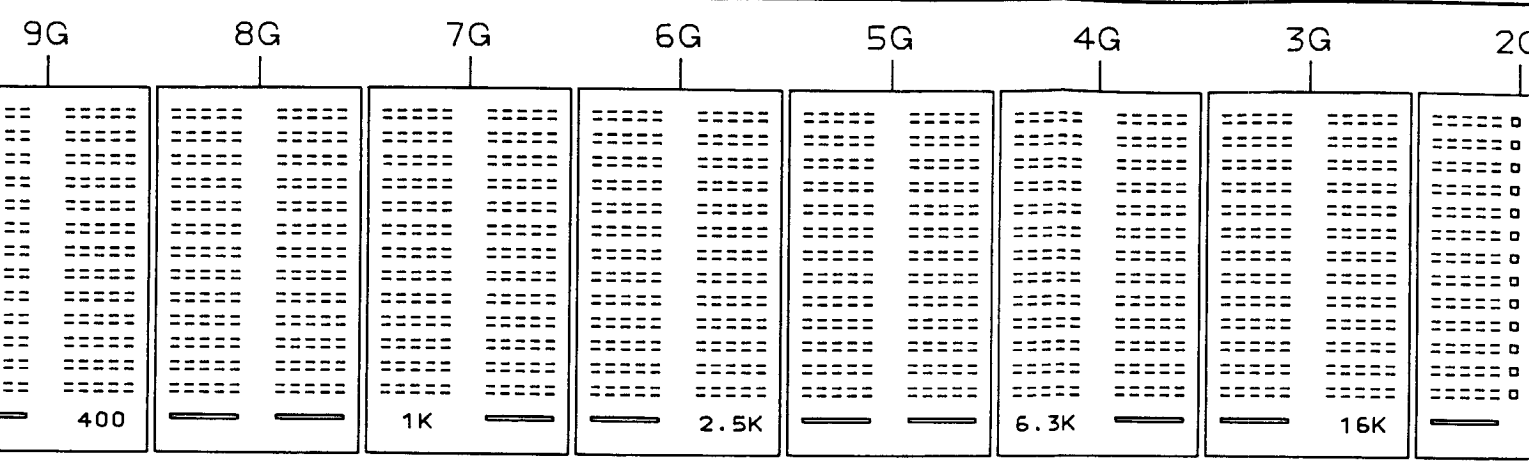



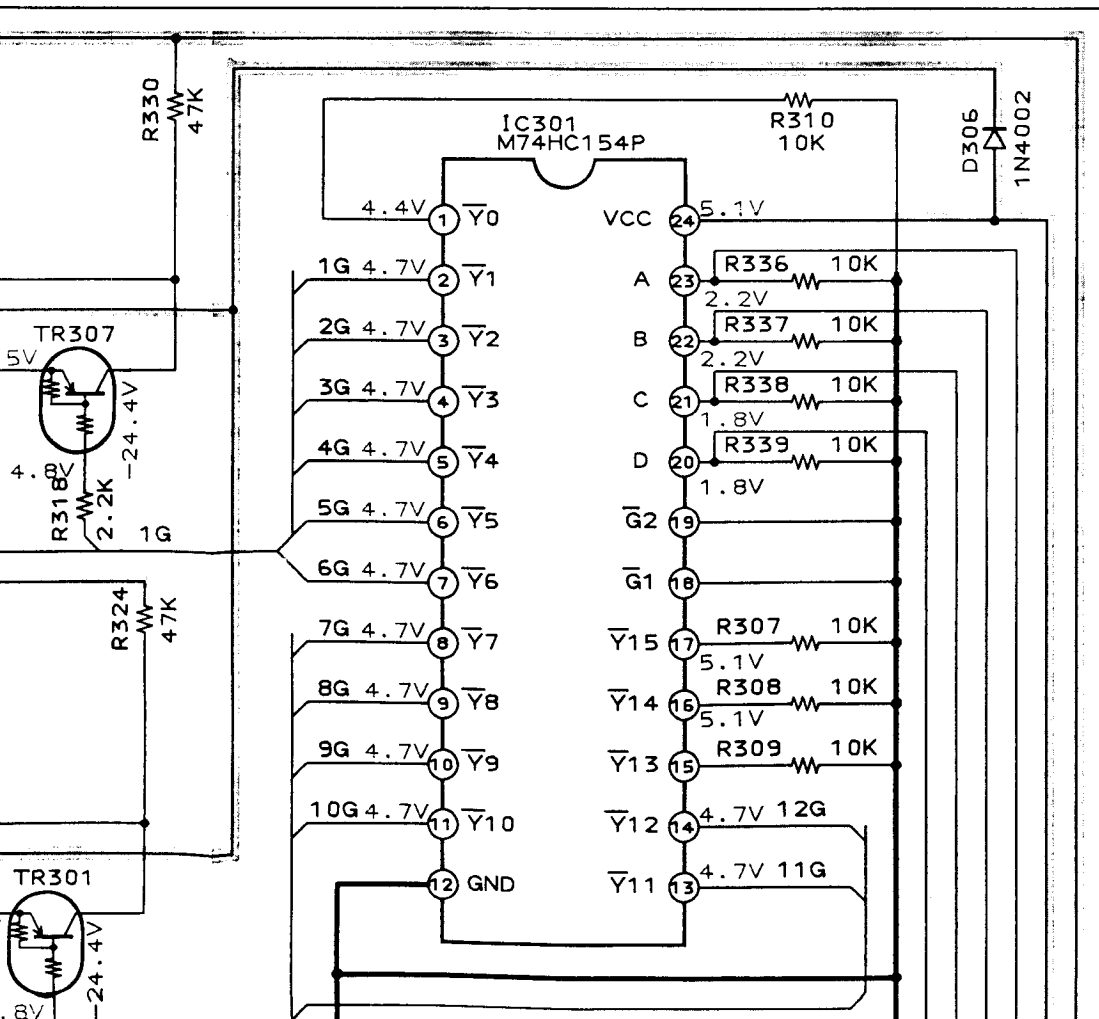
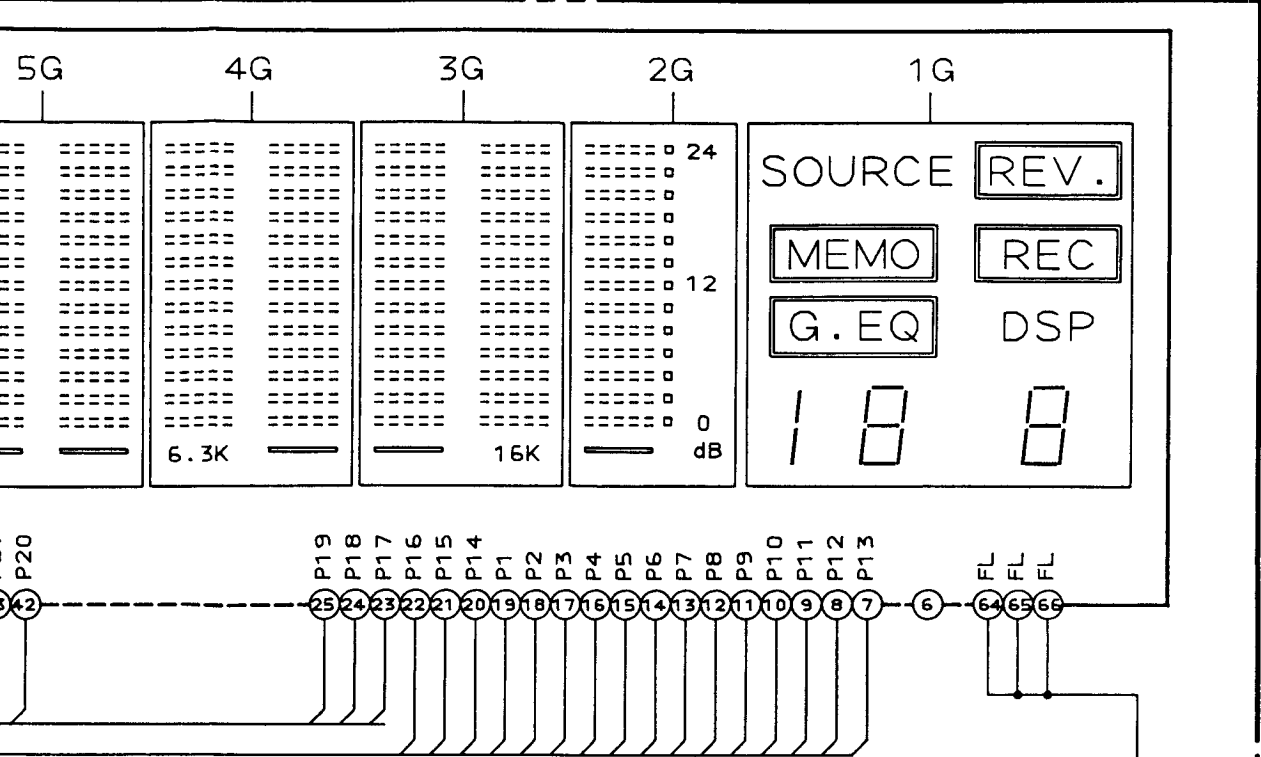

FL301  
BJ048GK

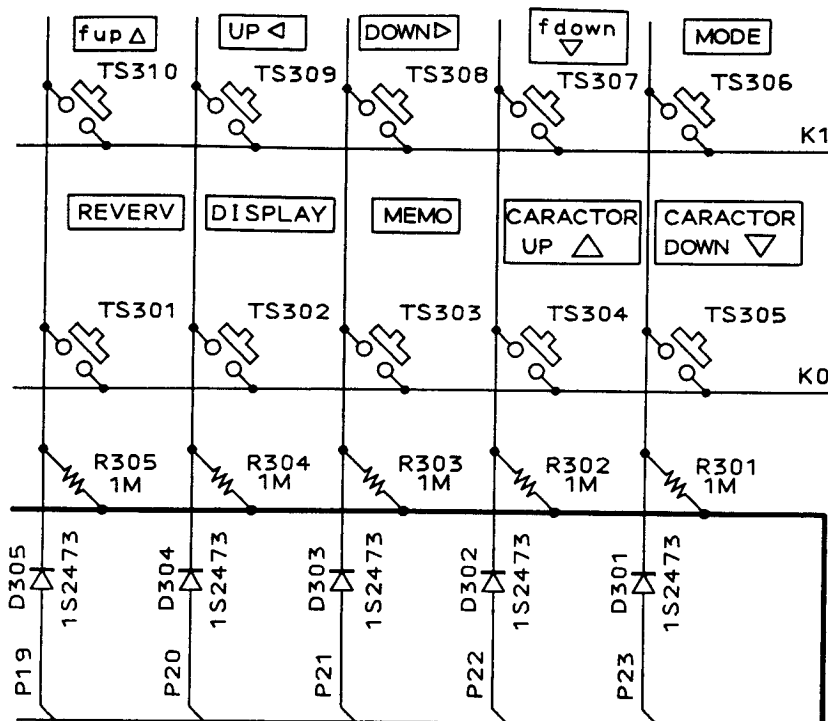

**RTV servis Horvat**

Kešinci, 31402 Semeljci

031-856-139

031-856-637

098-788-319

[rtv-servis-horvat@os.tel.hr](mailto:rtv-servis-horvat@os.tel.hr)

Croatia

TR301~312 : DTA124XL

TS301~310 : SOR-123HS

FRONT PCB D3016A502B

**NOTE:**

UNLESS OTHERWISE SPECIFIED

ALL RESISTORS IN OHMS

ALL CAPACITORS IN  $\mu$ F (P=PF)

ALL ELECTROLYTIC CAPACITORS IN  $\mu$ F/WV

INDICATED VOLTAGES WERE MEASURED

DURING THE EQUALIZER'S FLAT MODE.

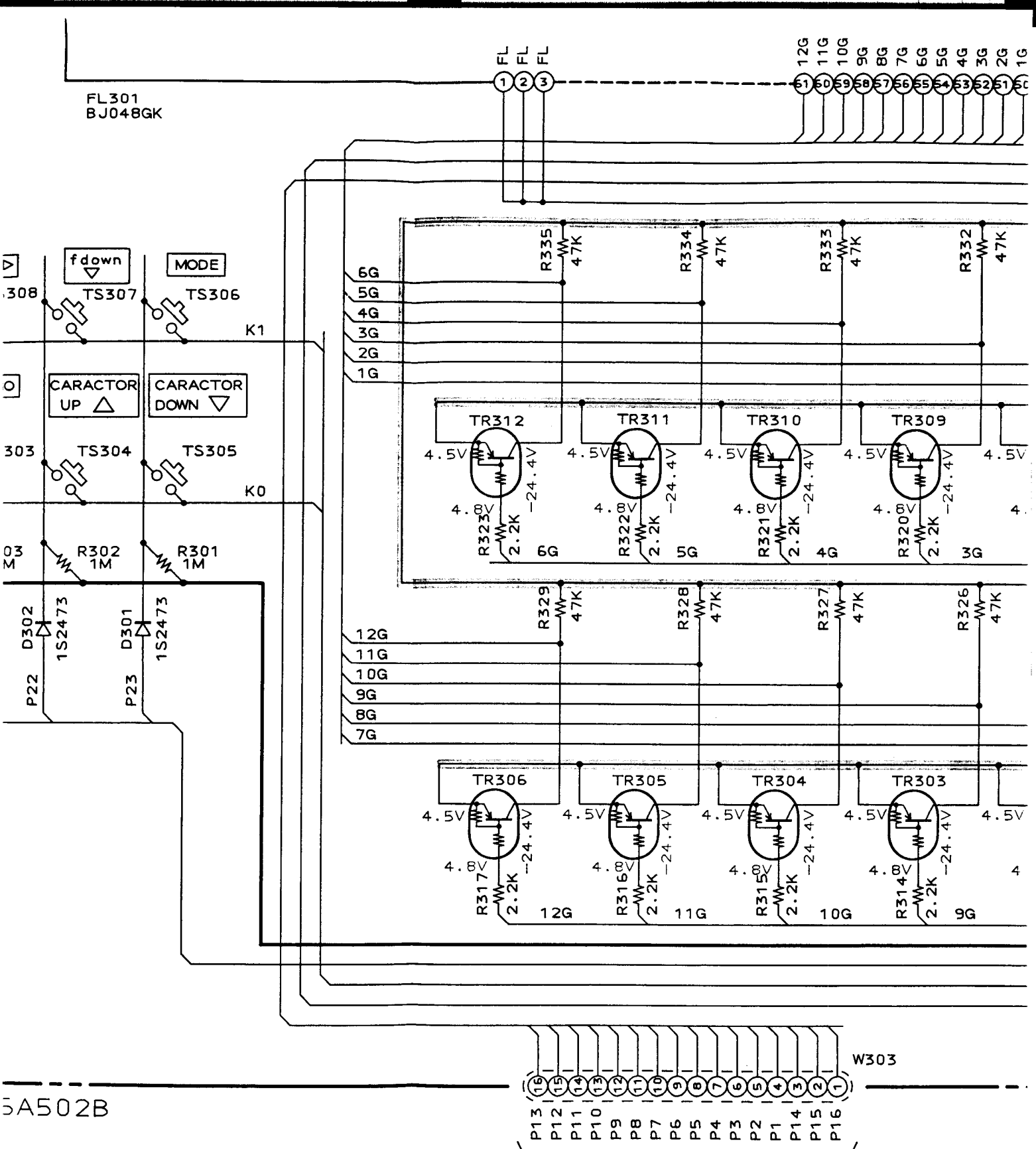

NOTE:  
 UNLESS OTHERWISE SPECIFIED  
 ALL RESISTORS IN OHMS  
 ALL CAPACITORS IN  $\mu$ F (P=PF)  
 ALL ELECTROLYTIC CAPACITORS IN  $\mu$ F/WV

INDICATED VOLTAGES WERE MEASURED  
 DURING THE EQUALIZER'S FLAT MODE.

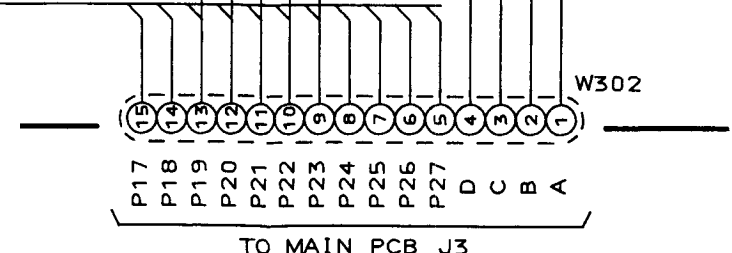
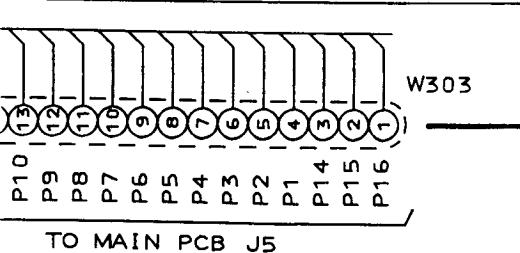
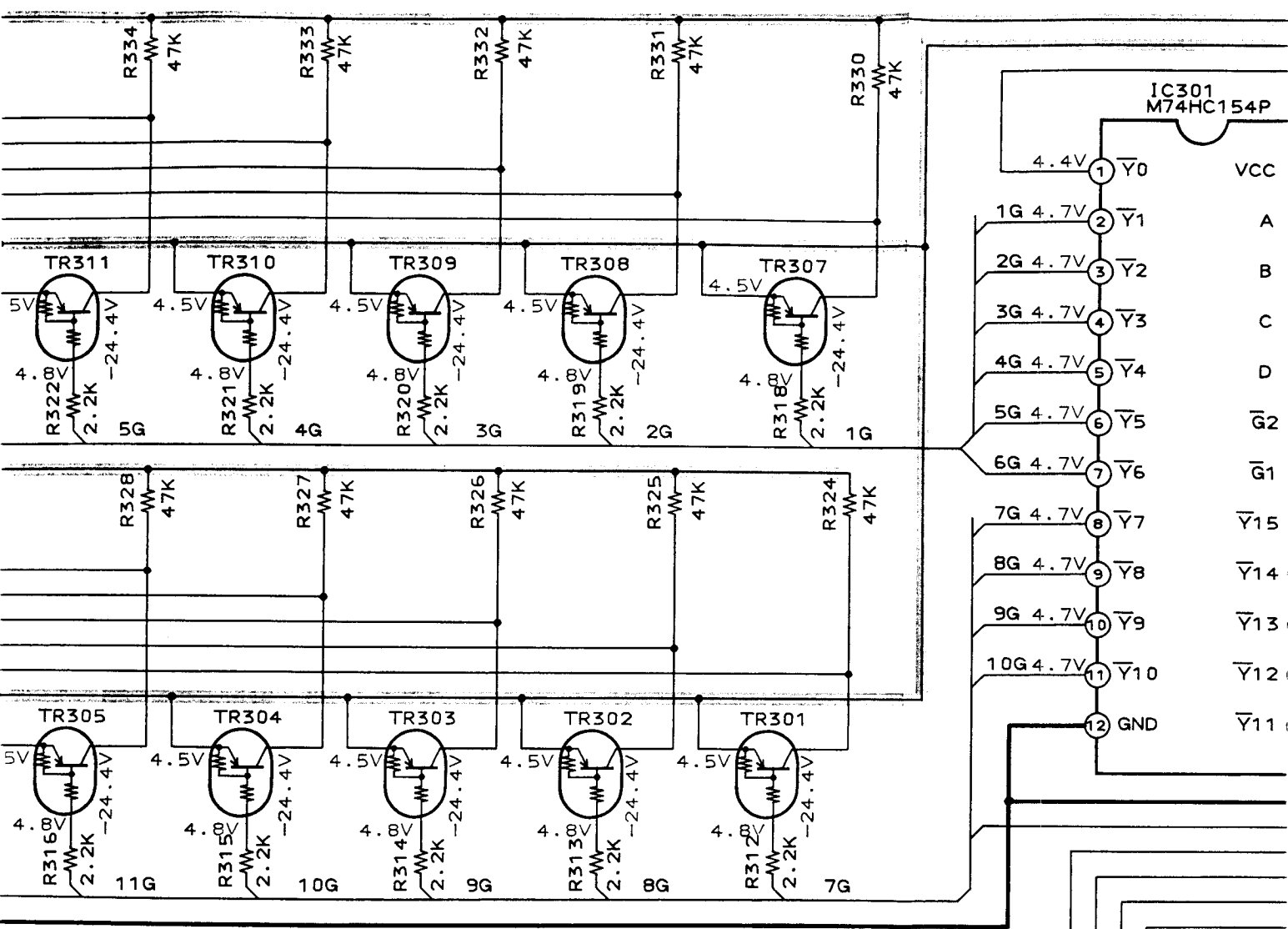
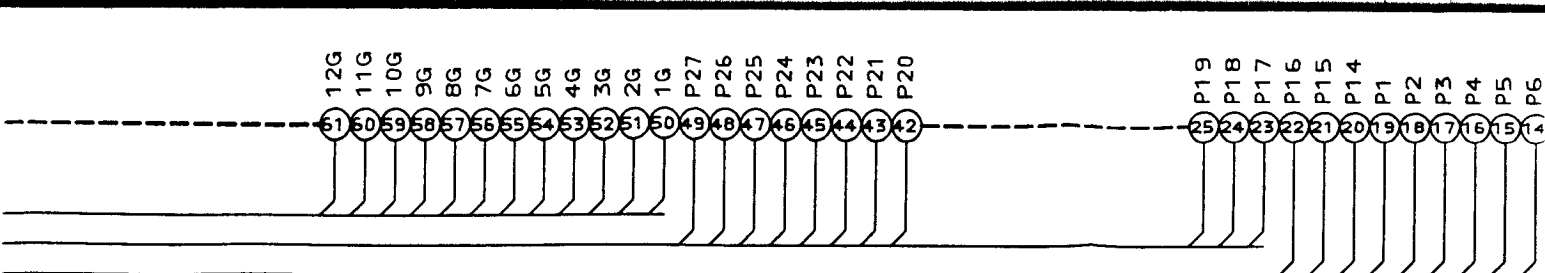

(POWER SUPPLY) LINE

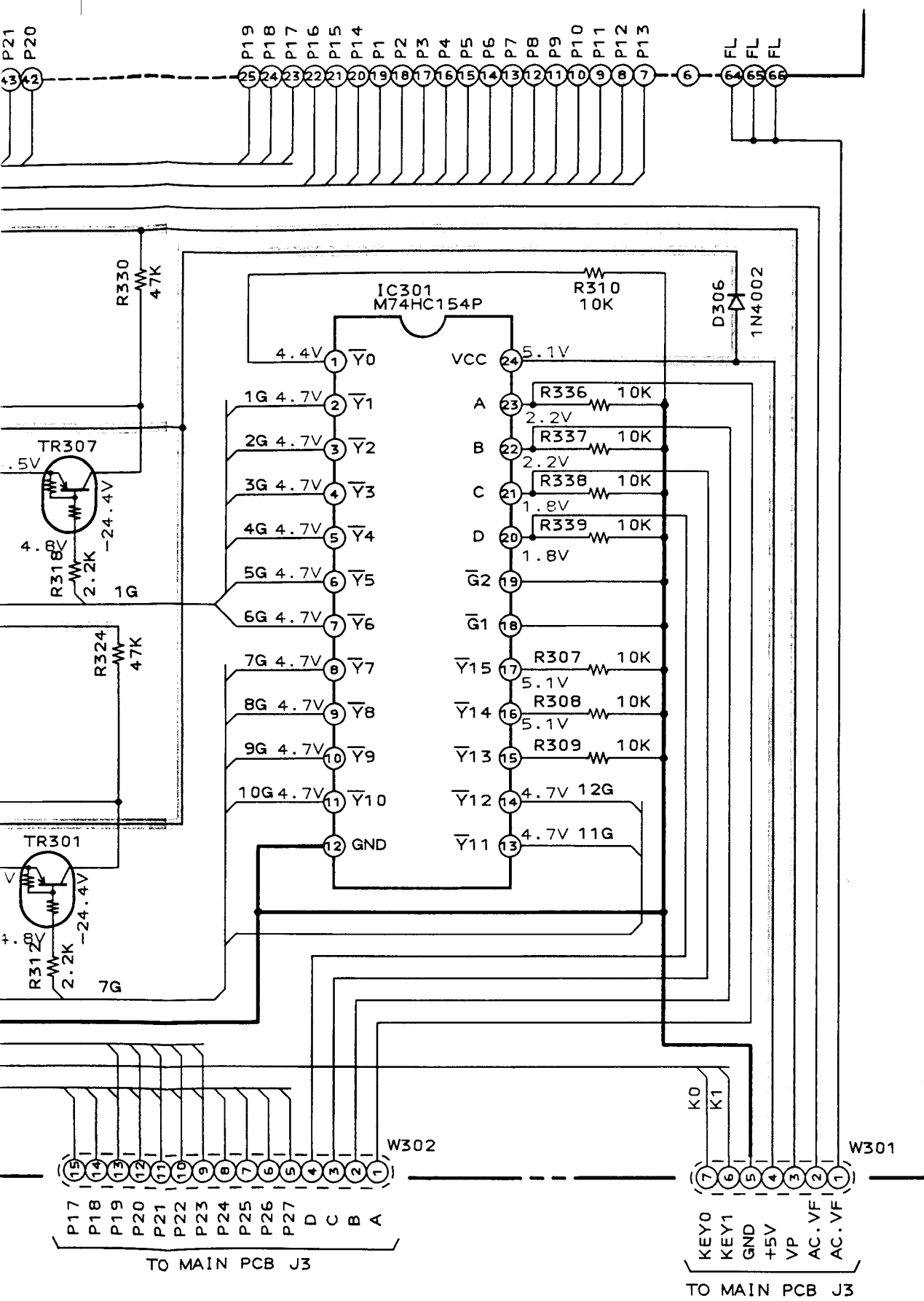

POWER SUPPLY) LINE

EA-750  
 FRONT  
 SCHEMATIC DIAGRAM  
 No. 8-3 D301602M  
 A2

3  
 4  
 5  
 6  
 7  
 8

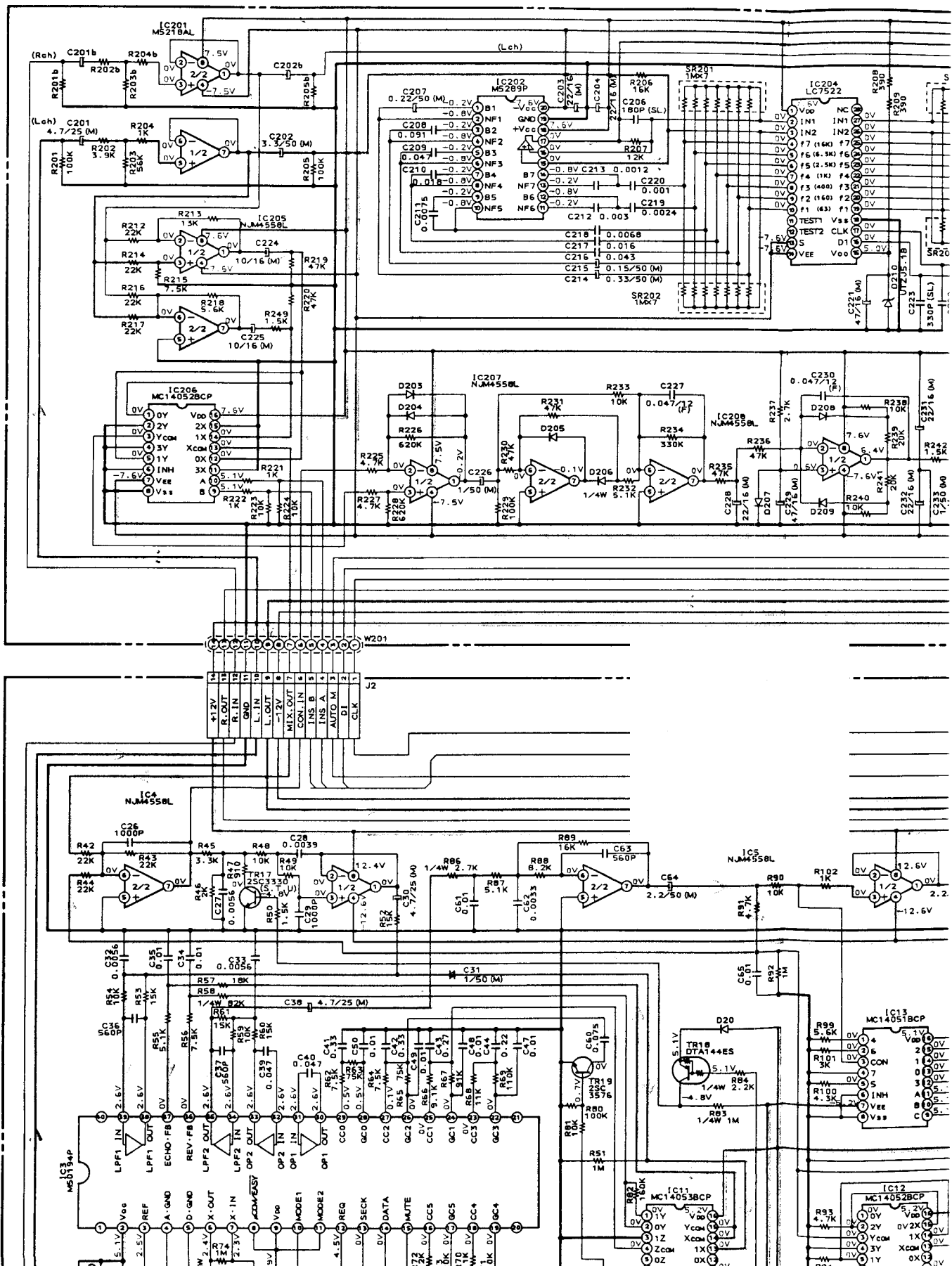

C

D

E

F

SUB PCB D3016A502A

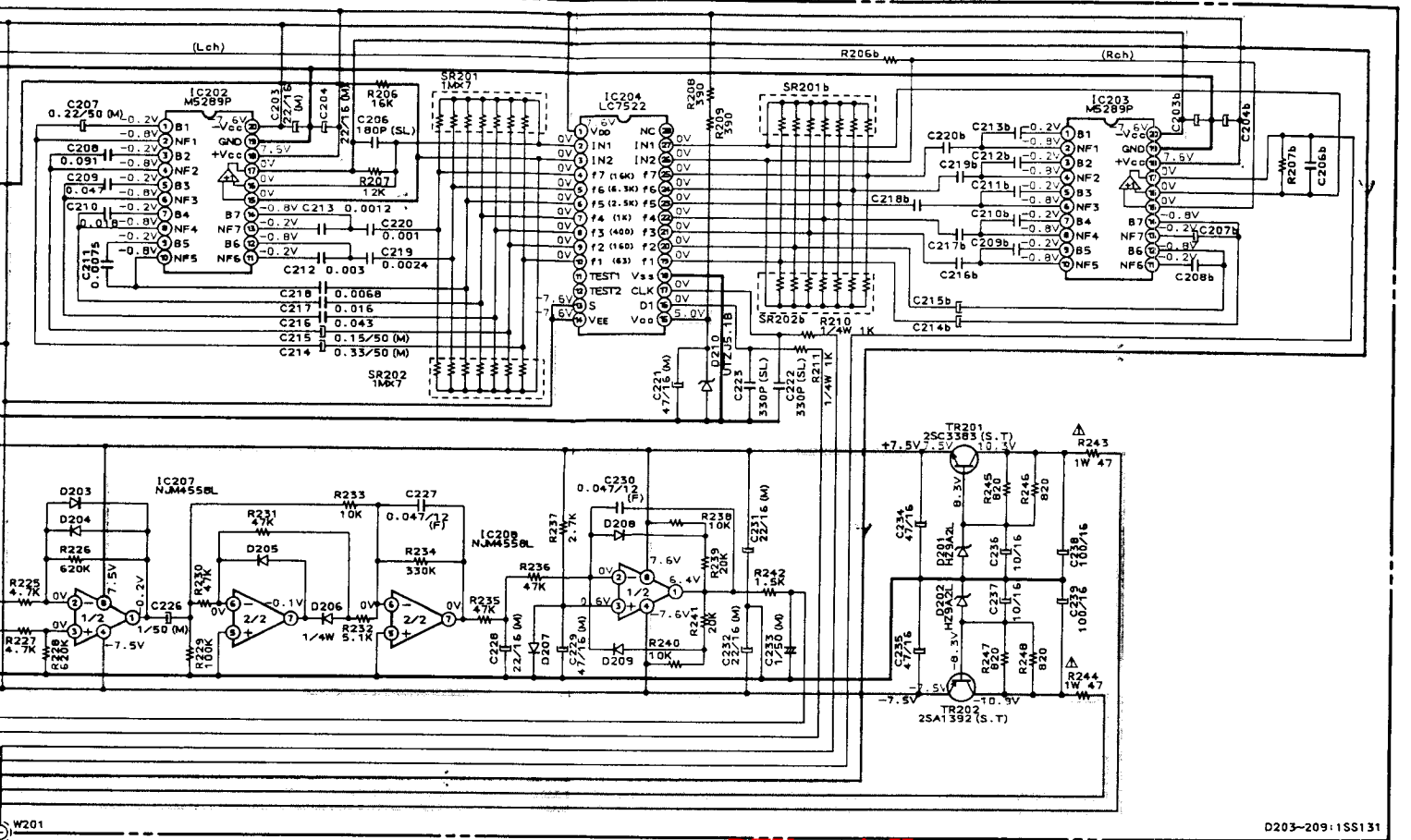

D203-209:1SS131

**RTV servis Horvat**

Kešinci, 31402 Semeljei

031-856-139

031-856-637

098-788-319

[rtv-servis-horvat@os.tel.hr](mailto:rtv-servis-horvat@os.tel.hr)

Croatia

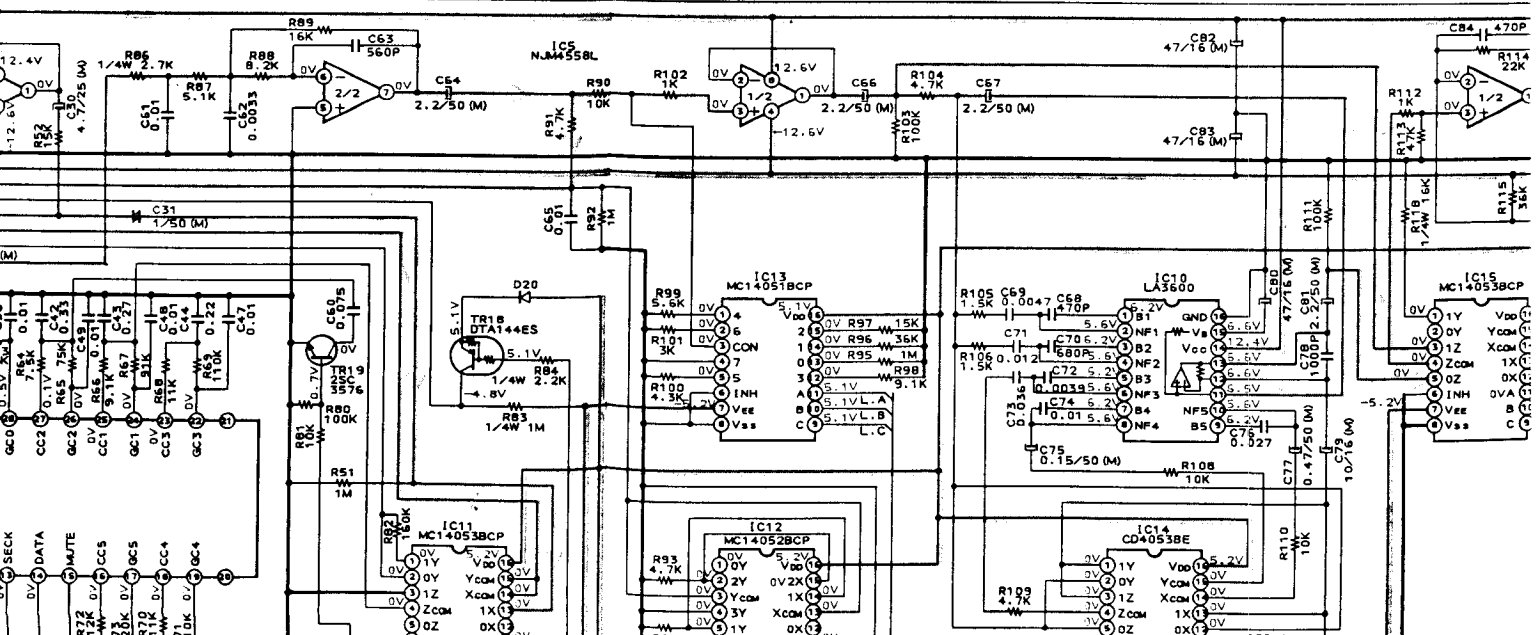

SUB PCB D3016A502A

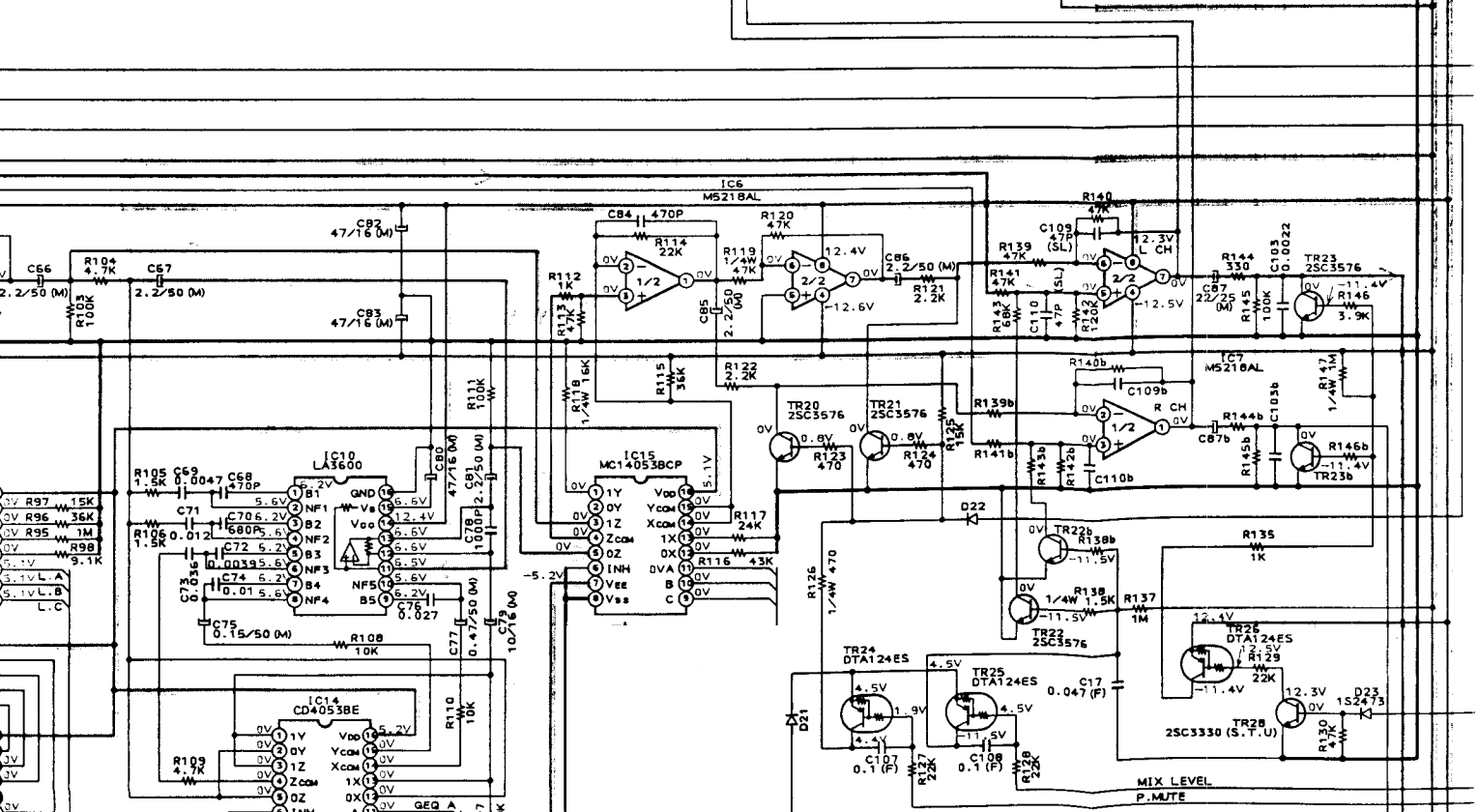
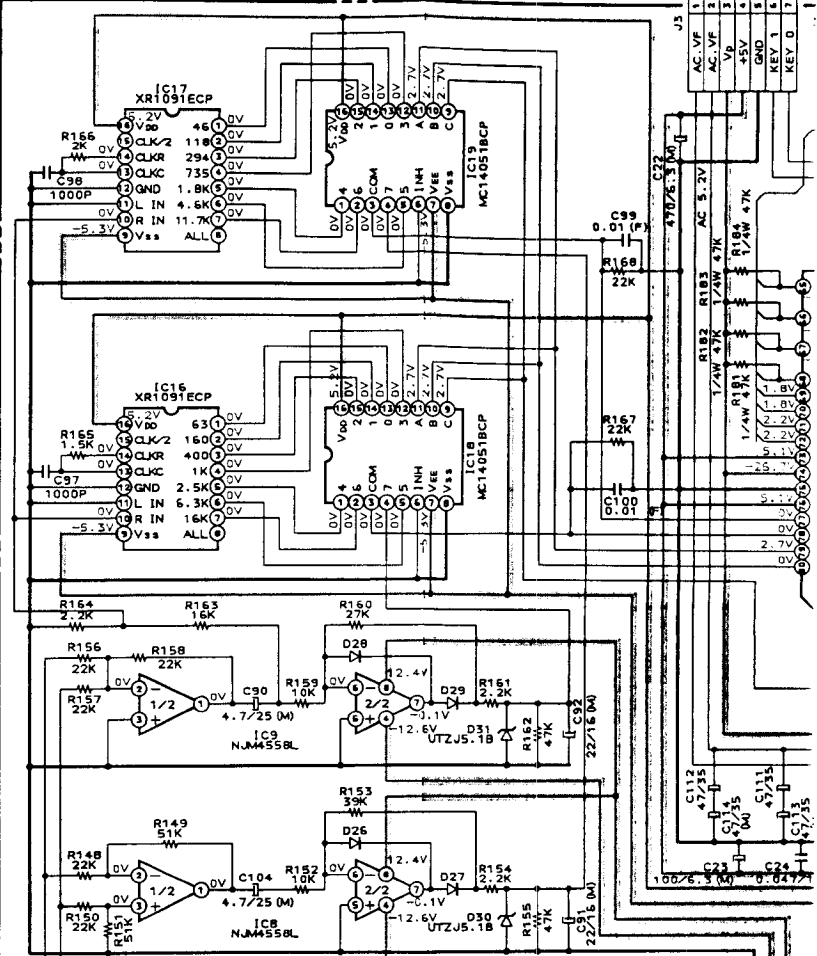
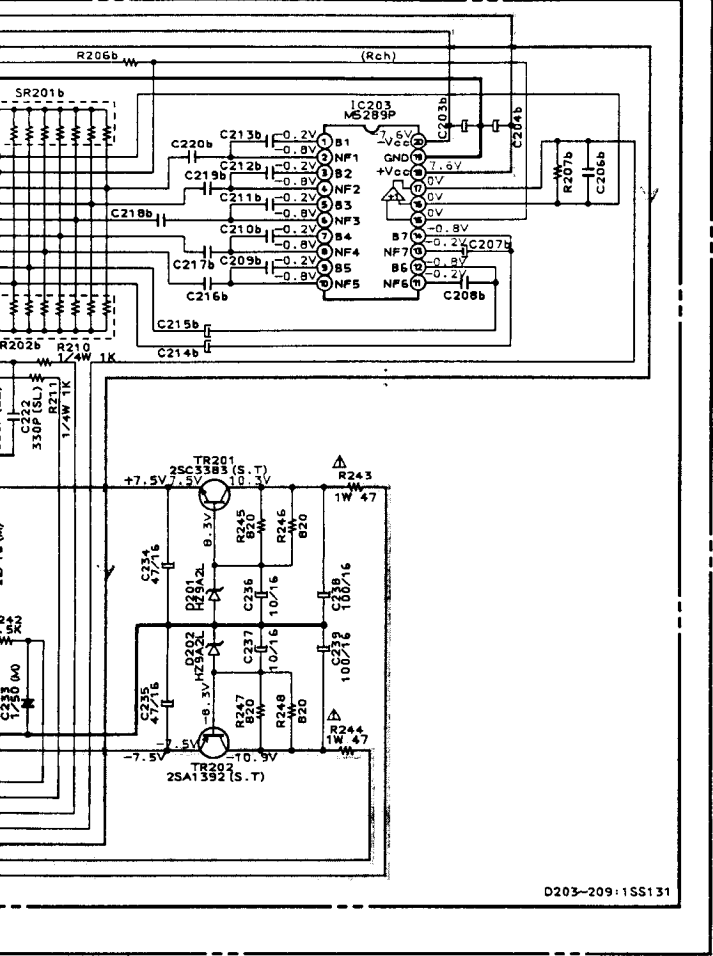



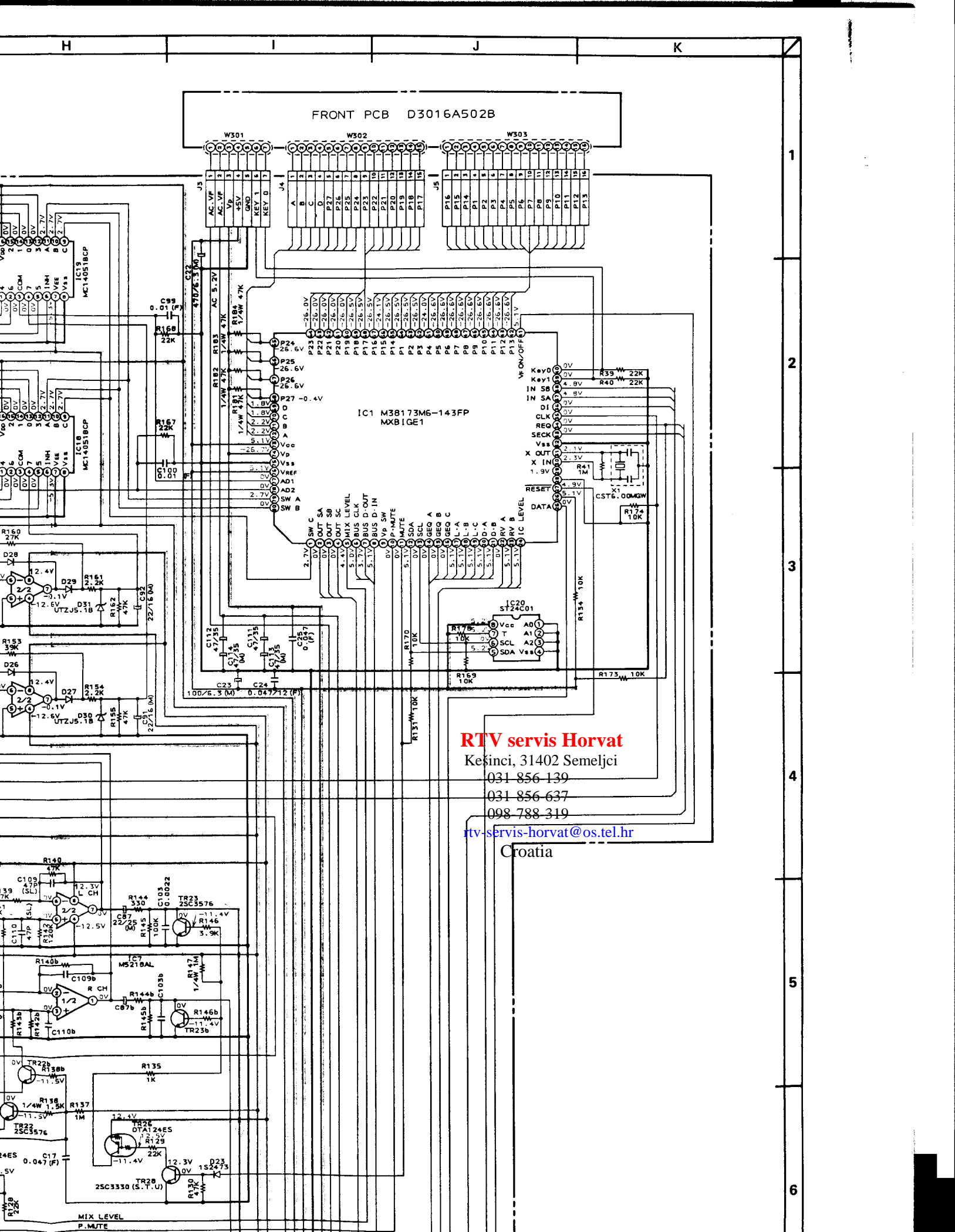

FRONT PCB D3016A502B

IC1 M38173M6-143FP  
MXB IGE1

**RTV servis Horvat**

Kesinci, 31402 Semeljci

031 856 139

031 856 637

098 788 319

[rtv-servis-horvat@os.tel.hr](mailto:rtv-servis-horvat@os.tel.hr)

Croatia

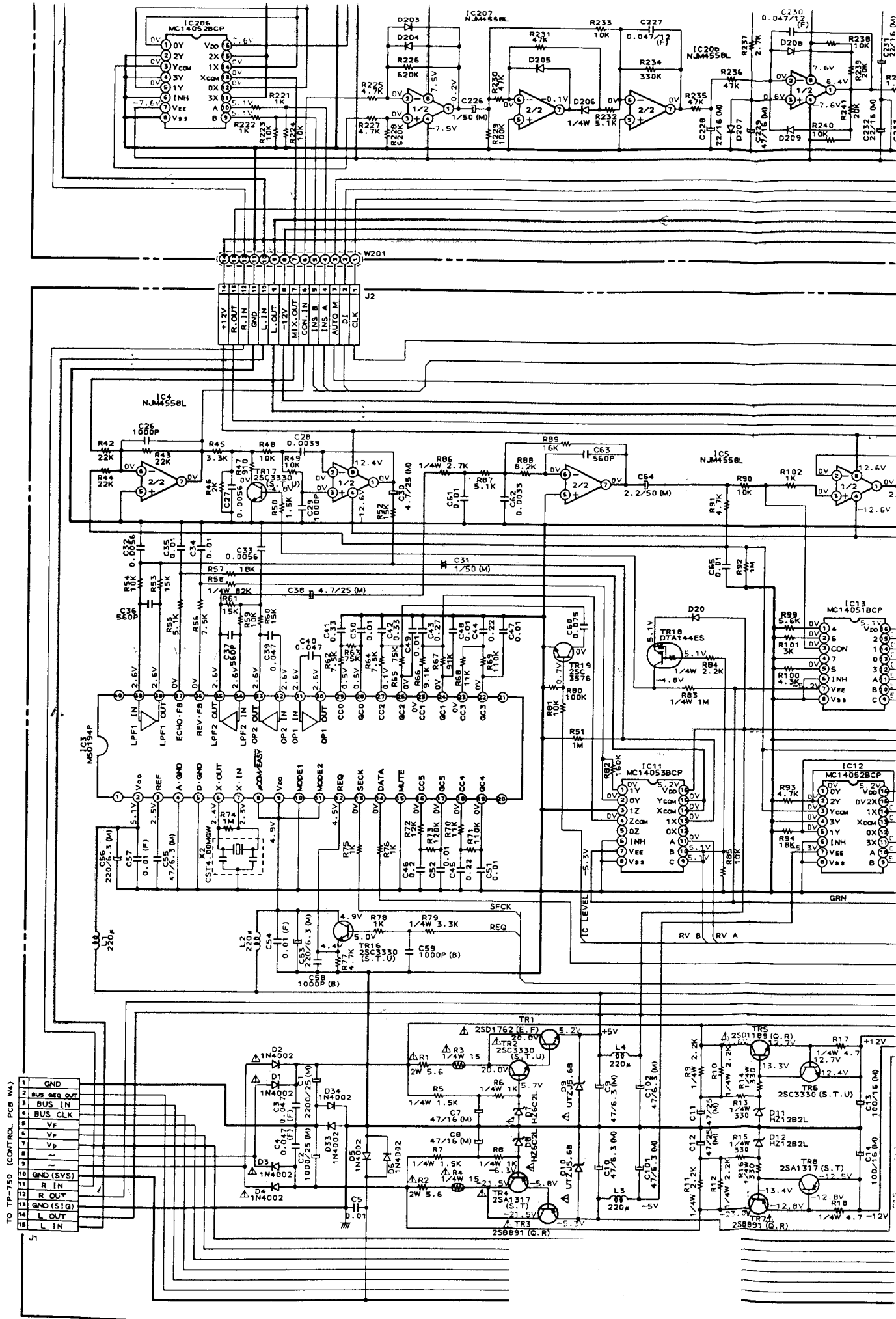

MAIN PCB D3016A5010

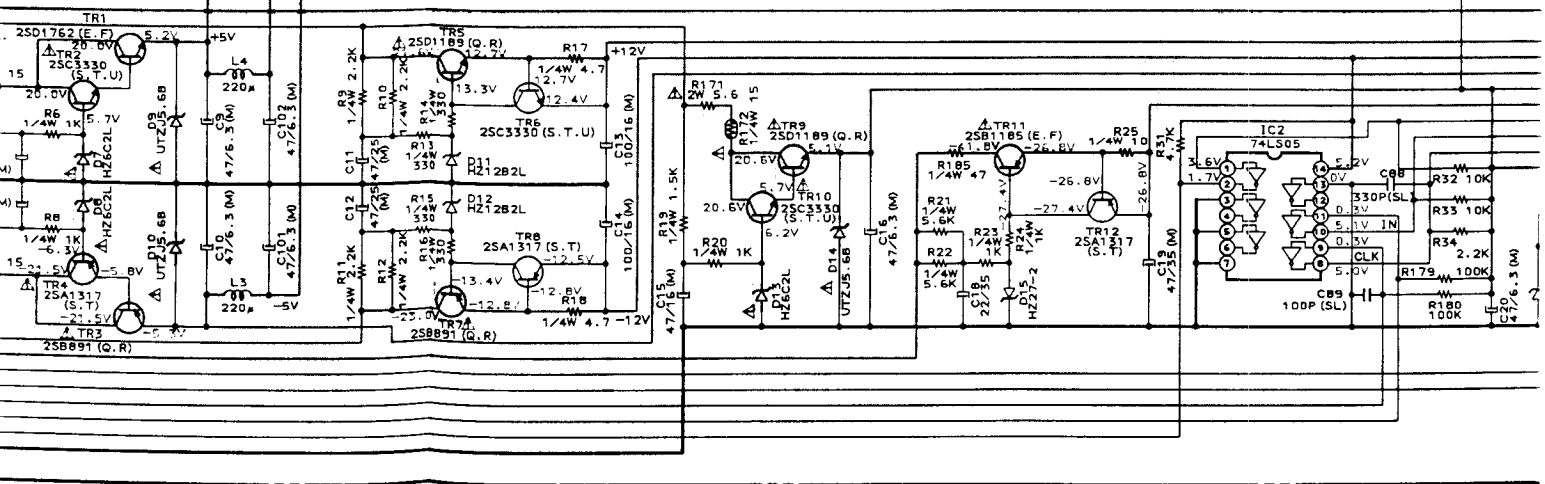
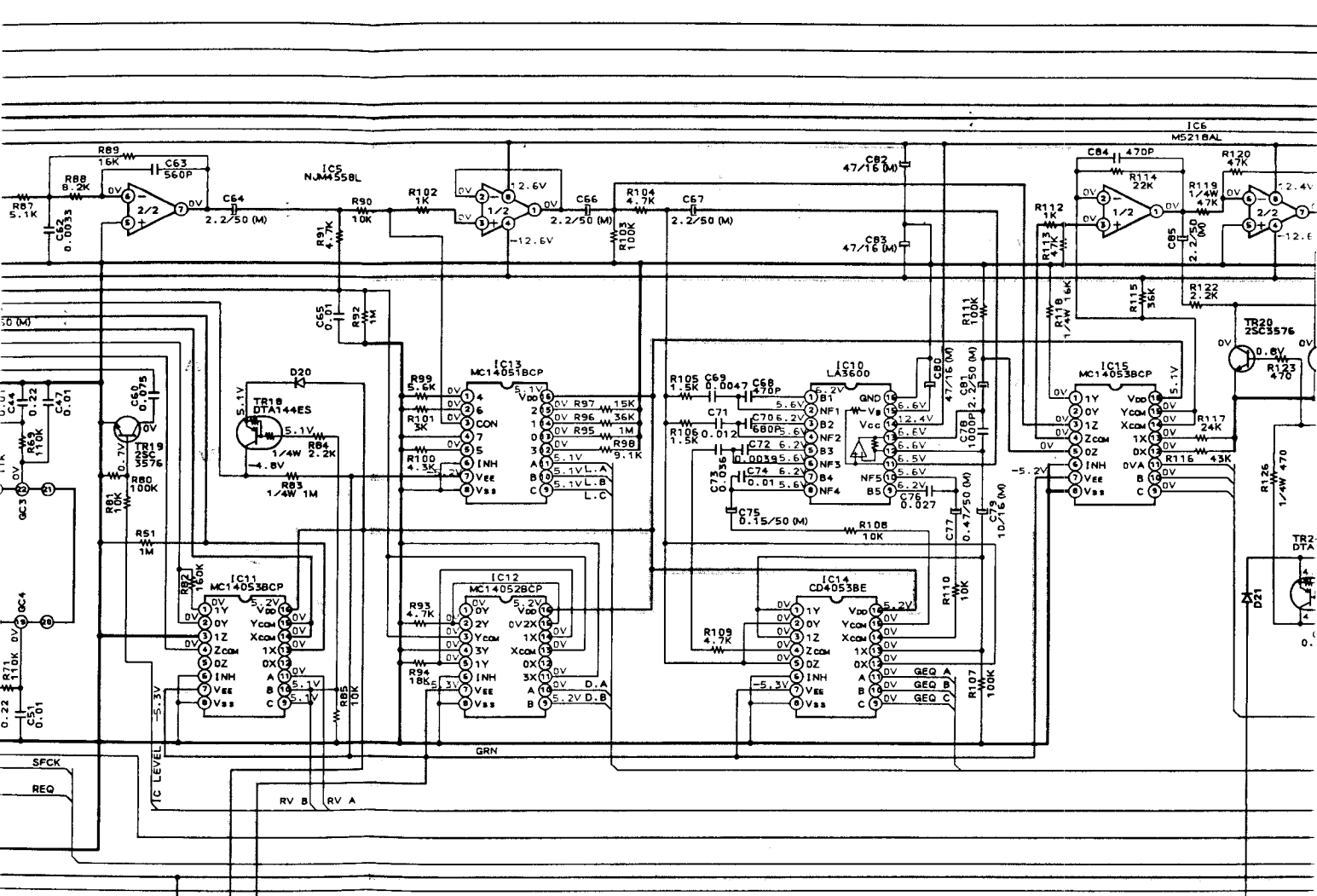
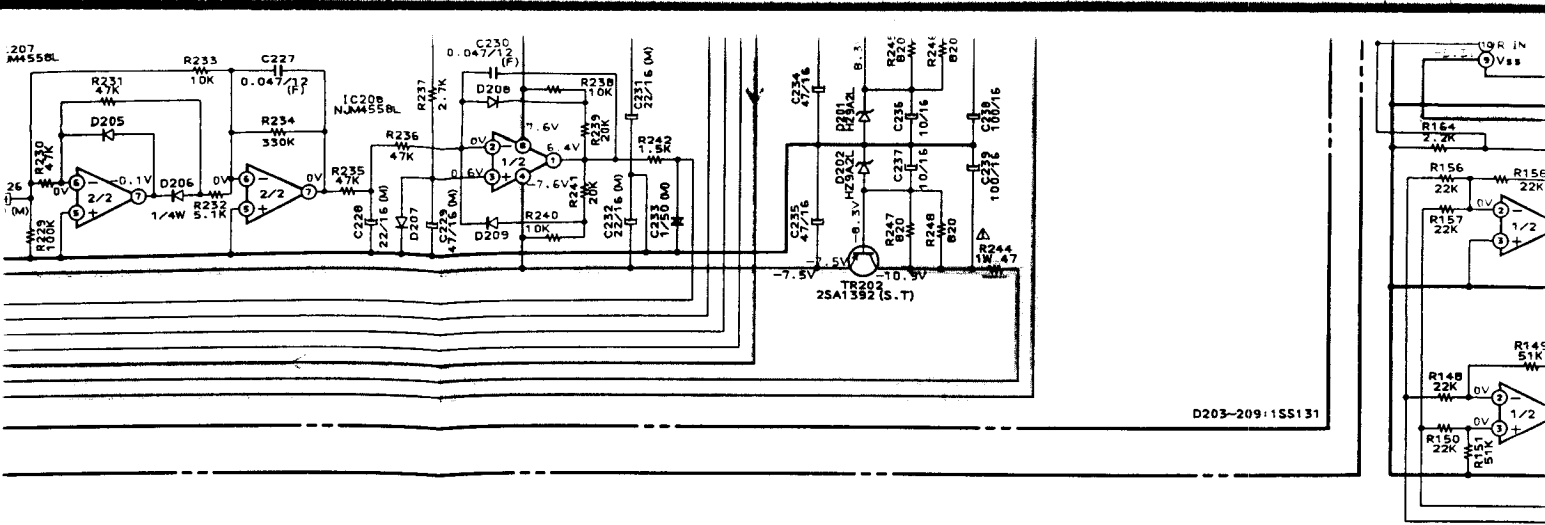

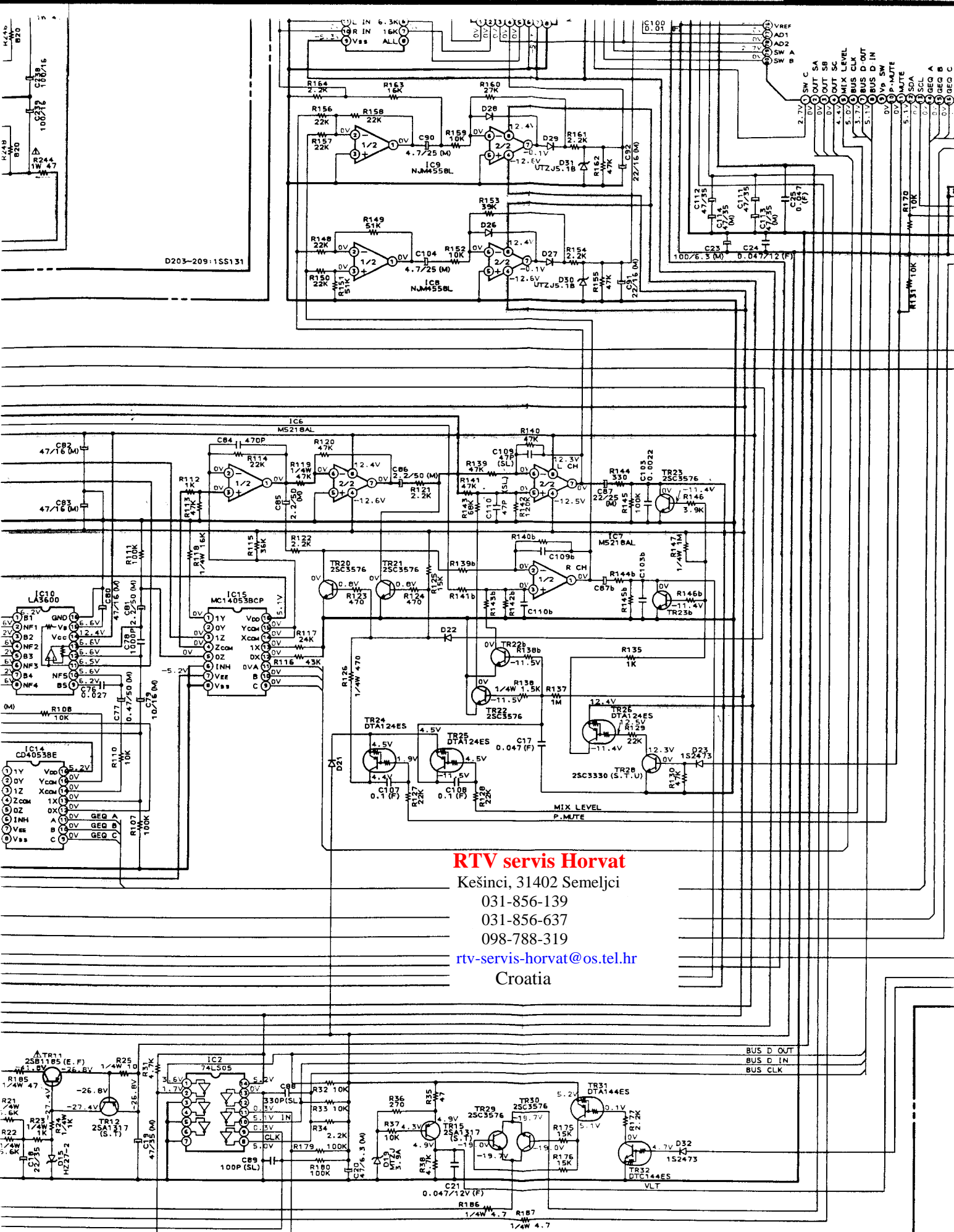

**RTV servis Horvat**

Kešinci, 31402 Semeljci

031-856-139

031-856-637

098-788-319

[rtv-servis-horvat@os.tel.hr](mailto:rtv-servis-horvat@os.tel.hr)

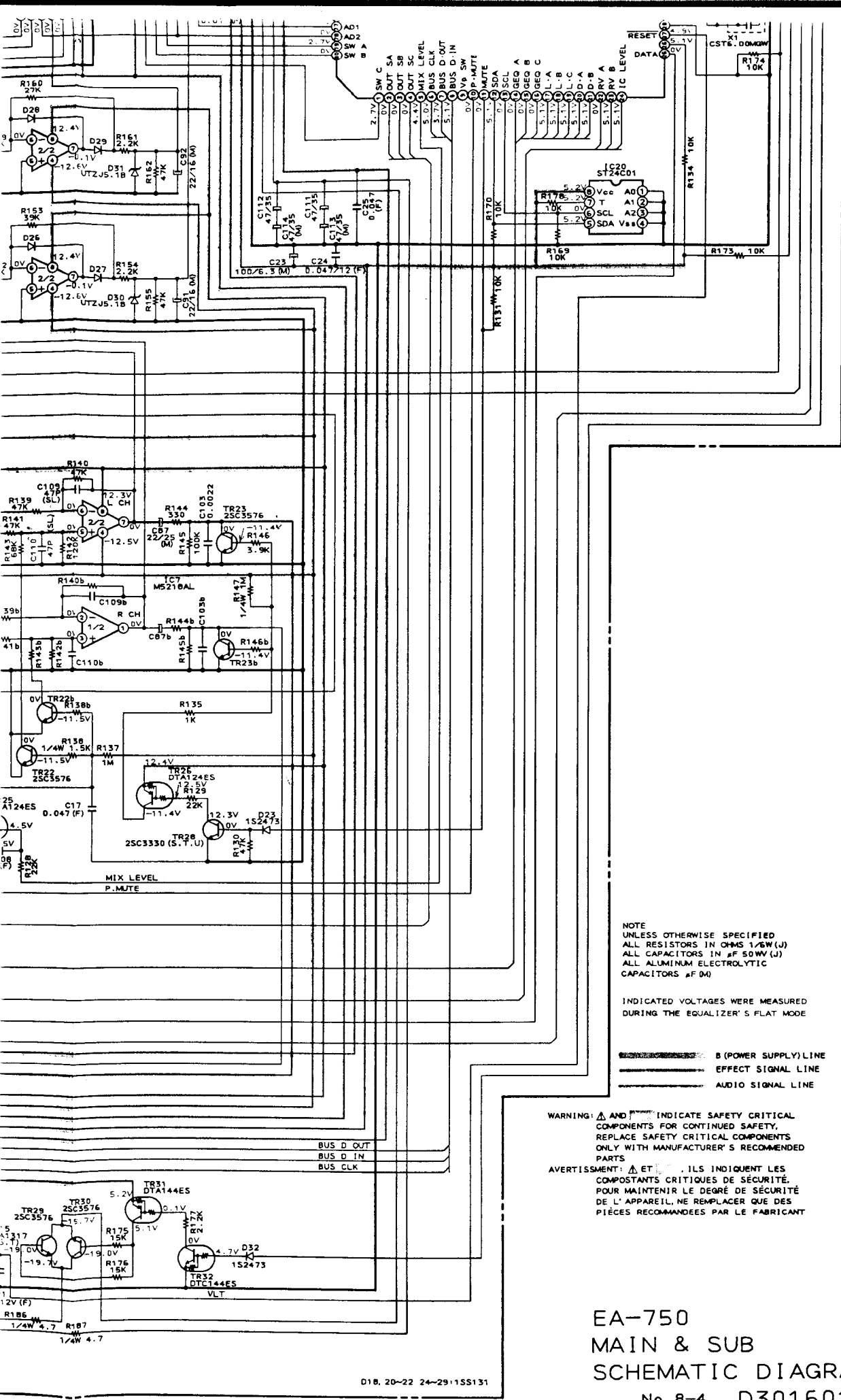

Croatia



3  
4  
5  
6  
7  
8

NOTE  
UNLESS OTHERWISE SPECIFIED  
ALL RESISTORS IN OHMS 1/6W(J)  
ALL CAPACITORS IN  $\mu$ F 50WV(J)  
ALL ALUMINUM ELECTROLYTIC  
CAPACITORS  $\mu$ F 0W

INDICATED VOLTAGES WERE MEASURED  
DURING THE EQUALIZER'S FLAT MODE

 B (POWER SUPPLY) LINE  
 EFFECT SIGNAL LINE  
 AUDIO SIGNAL LINE

WARNING:  $\Delta$  AND  $\square$  INDICATE SAFETY CRITICAL COMPONENTS FOR CONTINUED SAFETY. REPLACE SAFETY CRITICAL COMPONENTS ONLY WITH MANUFACTURER'S RECOMMENDED PARTS

AVERTISSEMENT:  $\Delta$  ET  $\square$  ILS INDICENT LES COMPOSANTS CRITIQUES DE SÉCURITÉ. POUR MAINTENIR LE DEGRÉ DE SÉCURITÉ DE L'APPAREIL, NE REMPLACER QUE DES PIÈCES RECOMMANDÉES PAR LE FABRICANT

EA-750  
MAIN & SUB  
SCHEMATIC DIAGRAM  
No. 8-4 D301601M  
A0

### PRINCIPAL PARTS LOCATION

#### ICs

- IC201 ..... C2
- IC202 ..... A4
- IC203 ..... A2
- IC204 ..... A3
- IC205 ..... B2
- IC206 ..... B3
- IC207 ..... B3
- IC208 ..... B4

#### WIRE

- W201 ..... C2,3

#### TRANSISTORS

- TR201 ..... C4
- TR202 ..... C3

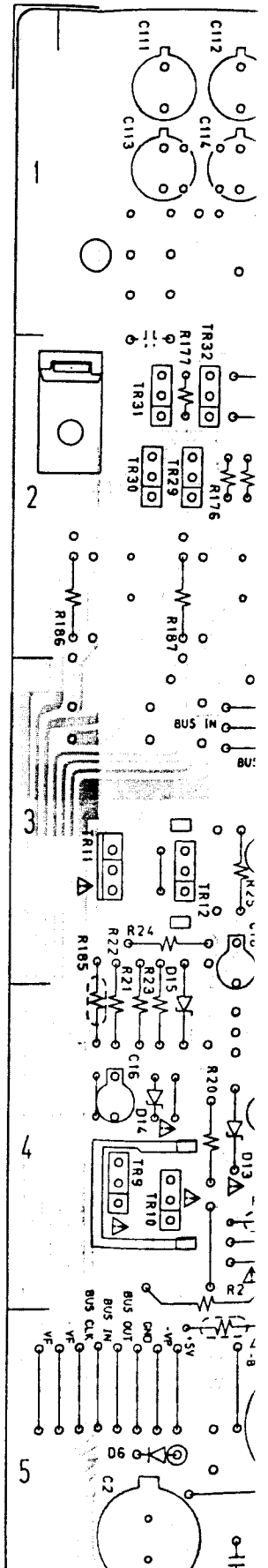
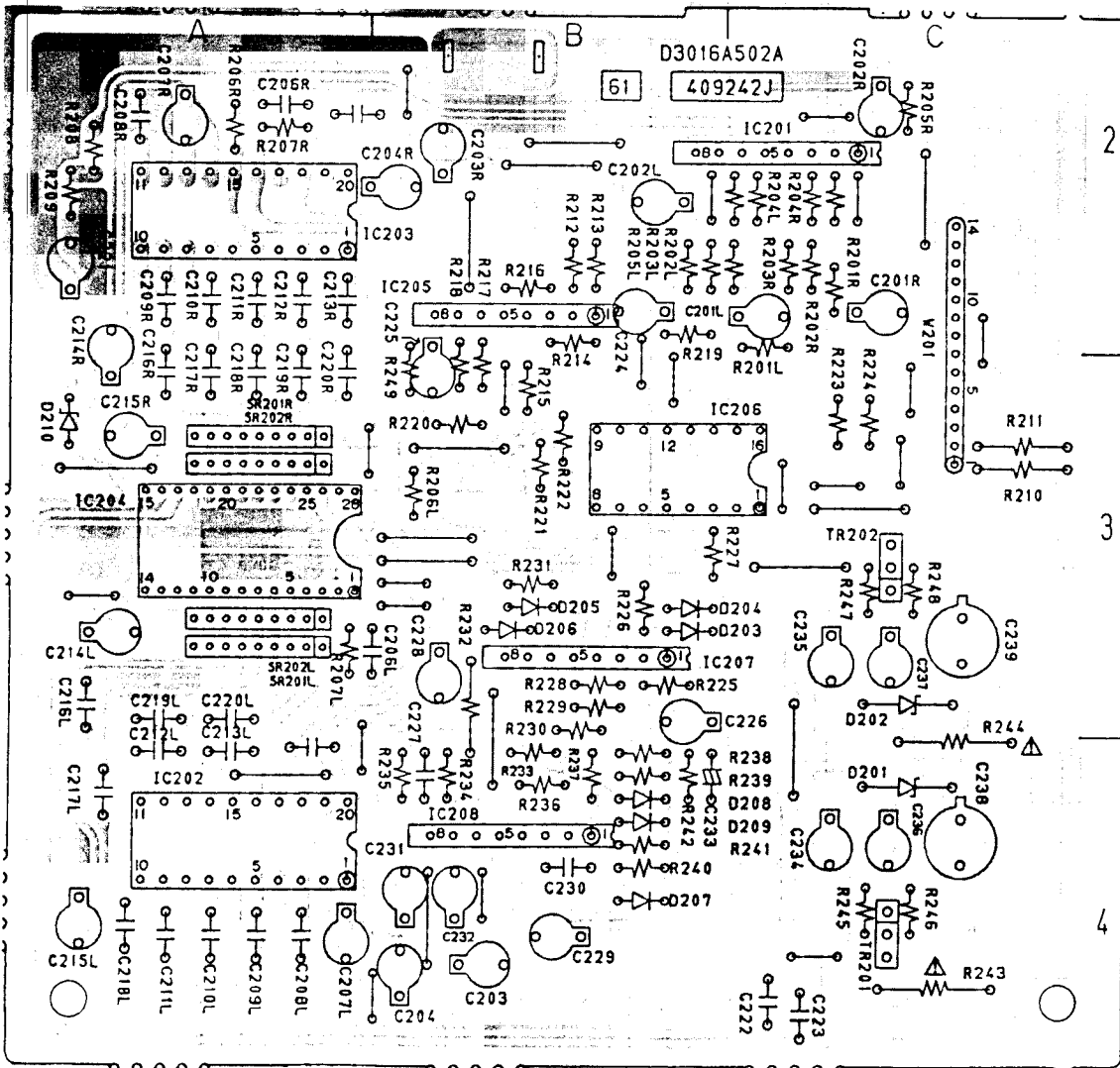

PRINCIPAL PARTS LOCATION

- 01 ..... C2
  - 02 ..... A4
  - 03 ..... A2
  - 04 ..... A3
  - 05 ..... B2
  - 06 ..... B3
  - 07 ..... B3
  - 08 ..... B4
- 
- 01 ..... C2,3
- 
- TRANSISTORS
- 01 ..... C4
  - 02 ..... C3

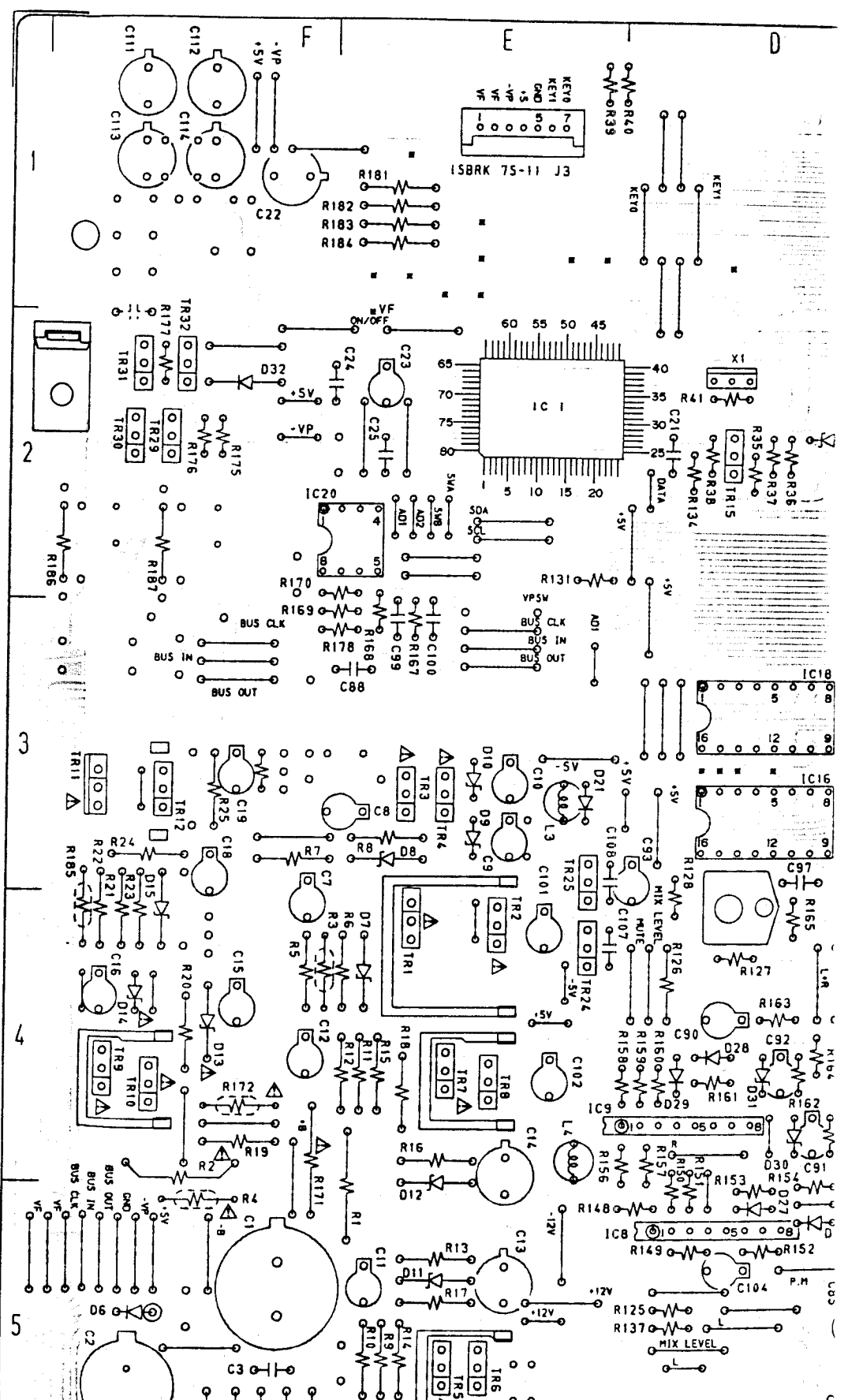
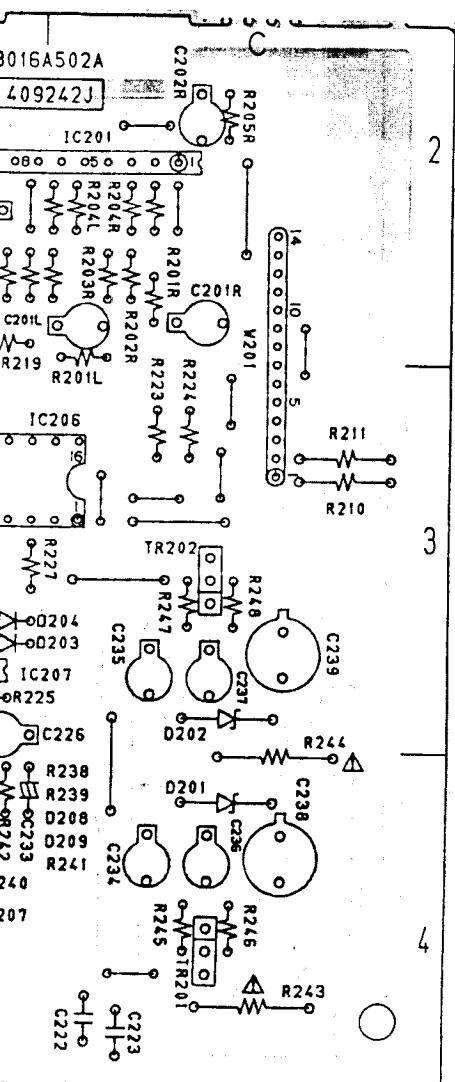



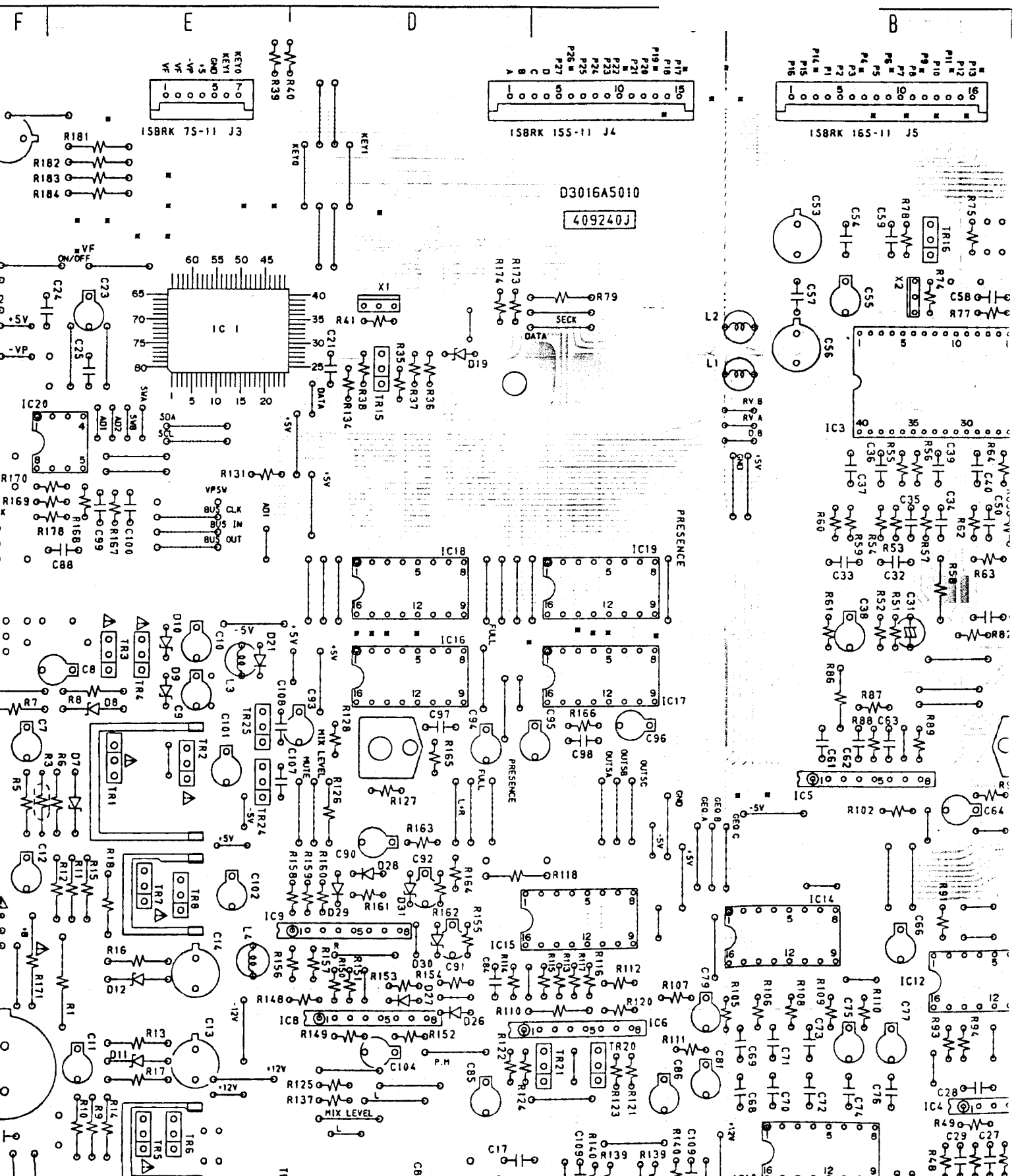

F

E

D

B

15BRK 75-11 J3

15BRK 155-11 J4

15BRK 165-11 J5

D3016A5010

409240J

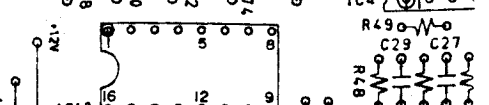
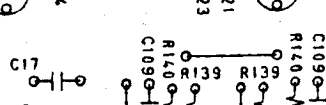
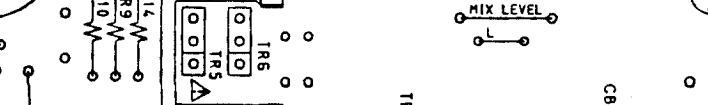
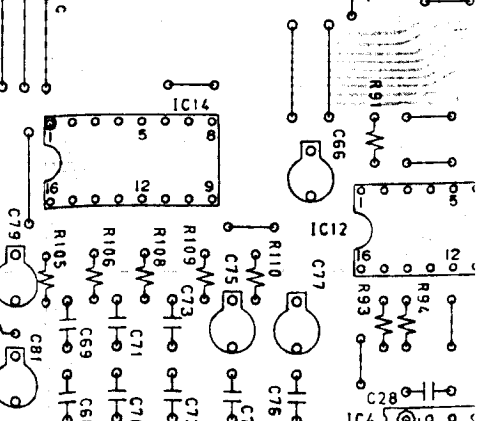
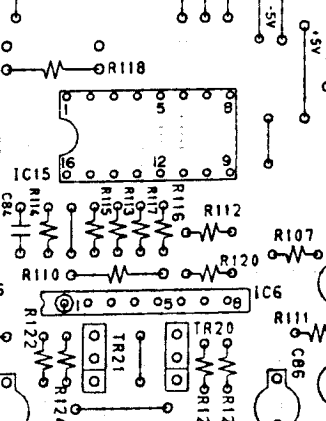
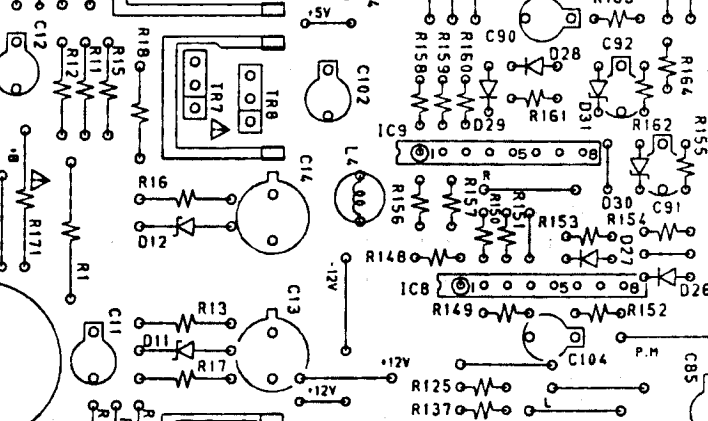
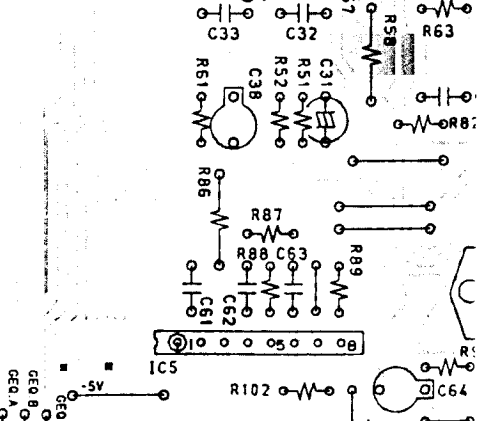
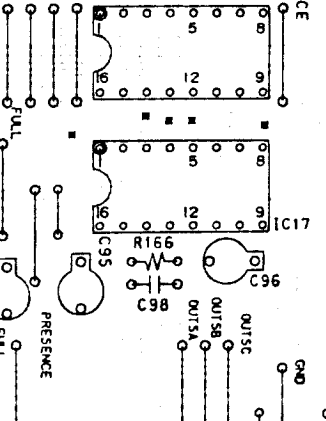
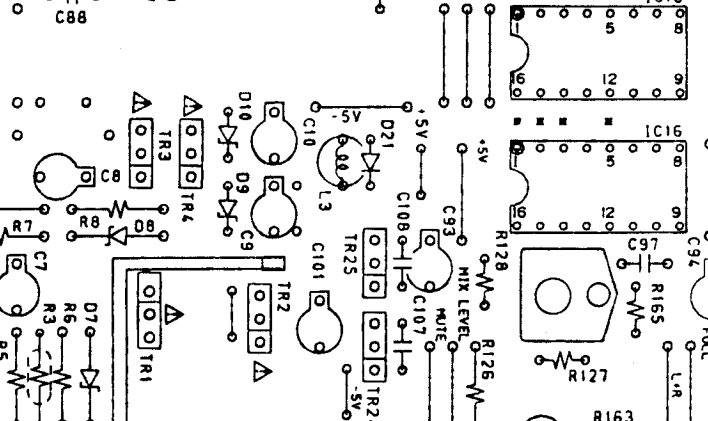
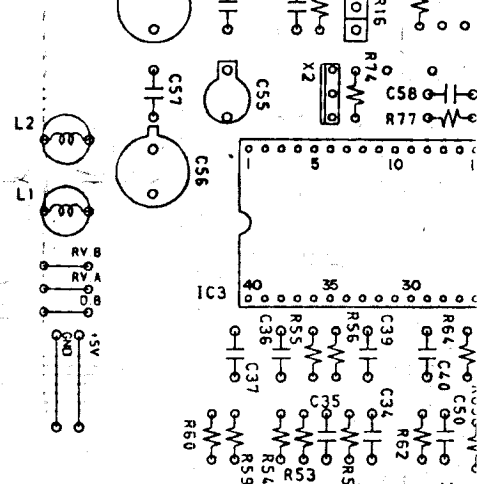
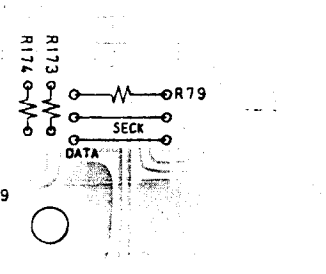
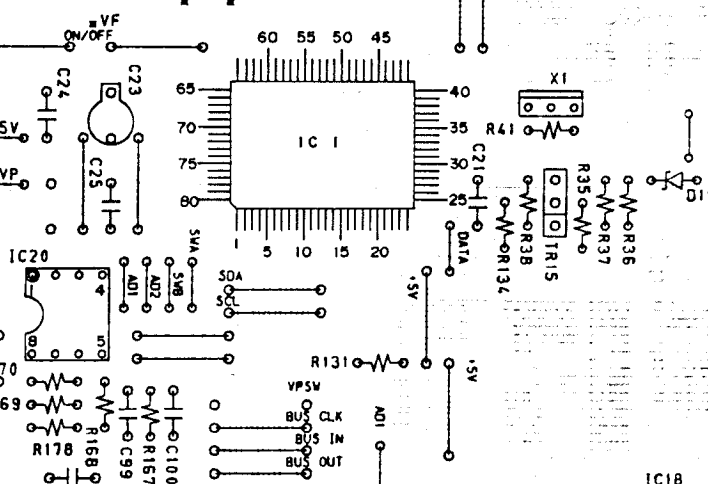
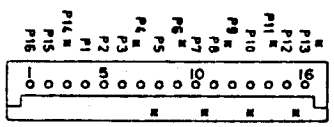
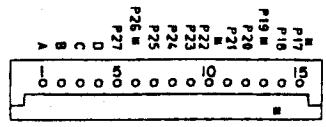
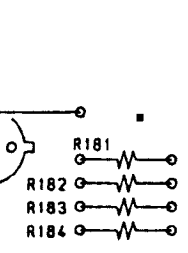



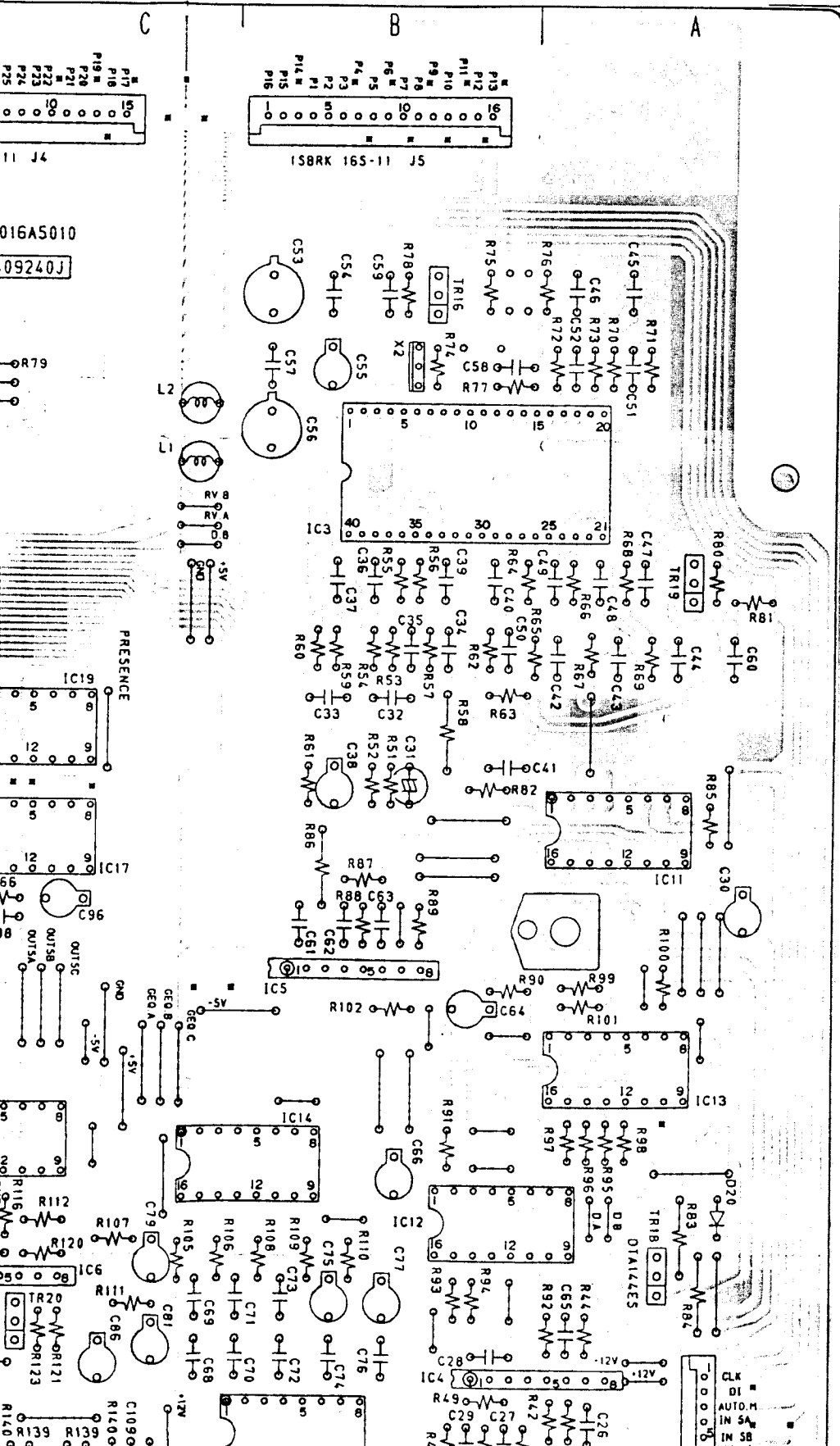

**PRINCIPAL PARTS LOCATION**

ICs

IC1	.....	E2
IC2	.....	F6
IC3	.....	B2
IC4	.....	A,B5
IC5	.....	B4
IC6	.....	C5
IC7	.....	C5,6
IC8	.....	D5
IC9	.....	D4
IC10	.....	B5
IC11	.....	A3
IC12	.....	A,B5
IC13	.....	A4
IC14	.....	C,B4
IC15	.....	C4
IC16	.....	D3
IC17	.....	C3
IC18	.....	D3
IC19	.....	C3
IC20	.....	E2

CONNECTORS

J1	.....	E6
J2	.....	A5,6
J3	.....	E1
J4	.....	C1
J5	.....	B1

TRANSISTORS

TR1	.....	E4
TR2	.....	E4
TR3	.....	E3
TR4	.....	E3
TR5	.....	E5
TR6	.....	E5
TR7	.....	E4
TR8	.....	E4
TR9	.....	F4
TR10	.....	F4
TR11	.....	F3
TR12	.....	F3
TR15	.....	D2
TR16	.....	B1
TR17	.....	B5,6
TR18	.....	A5
TR19	.....	A2
TR20	.....	C5
TR21	.....	C5
TR22	.....	C6
TR23	.....	D6
TR24	.....	E4
TR25	.....	E3
TR26	.....	E6
TR28	.....	E5,6
TR29	.....	F2
TR30	.....	F2
TR31	.....	F2
TR32	.....	F2

W201 ..... C2,3

TRANSISTORS

TR201 ..... C4

TR202 ..... C3

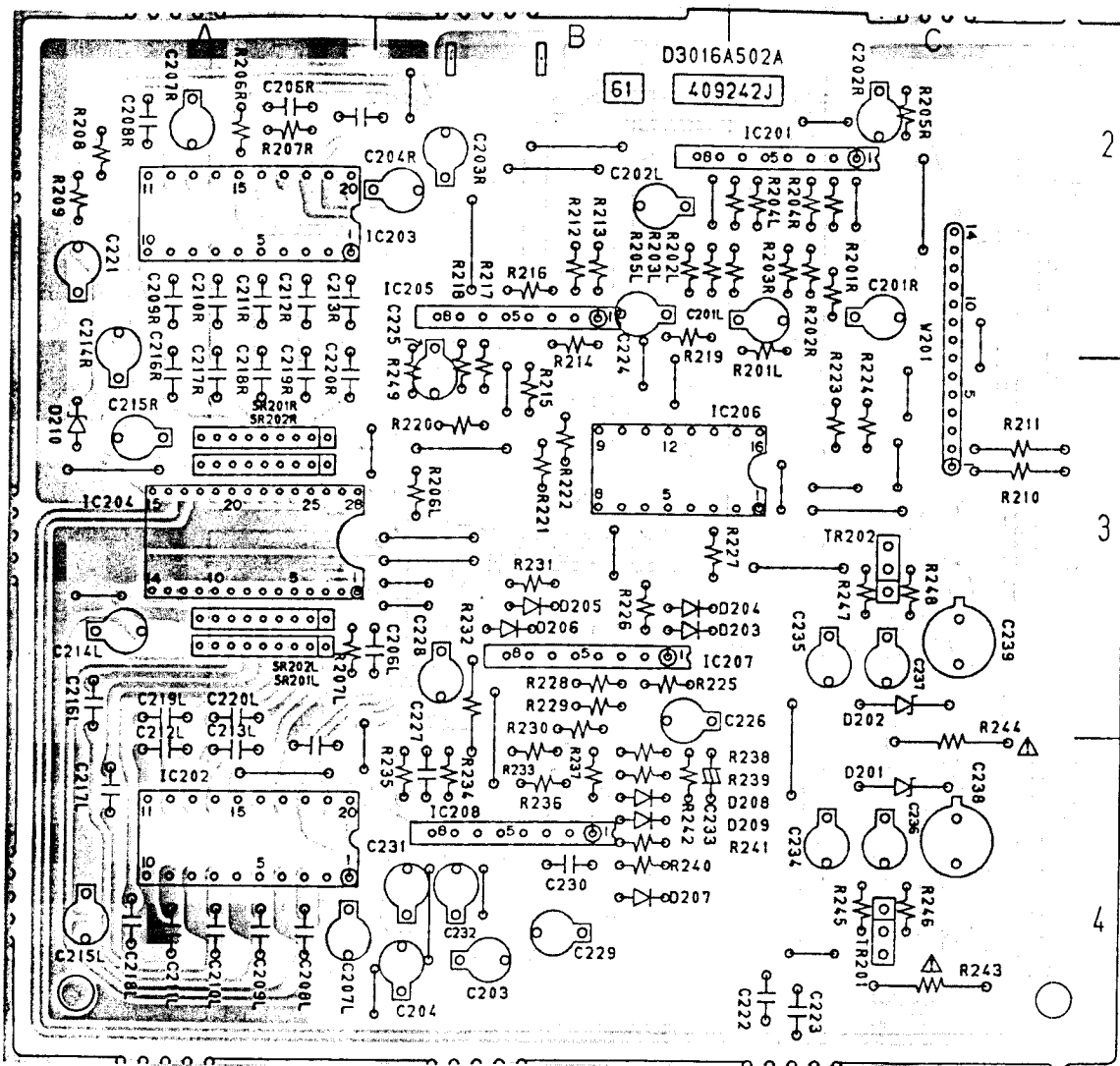

SUB PCB D3016A502A

NOTE : PARTS DIFFER DEPENDING ON MODEL NUMBER. REFER TO SCHEMATIC DIAGRAMS FOR PERTAINING PARTS INFORMATION.

WARNING: ⚠ INDICATES SAFETY CRITICAL COMPONENTS FOR CONTINUED SAFETY. REPLACE SAFETY CRITICAL COMPONENTS ONLY WITH MANUFACTURER'S RECOMMENDED PARTS

AVERTISSEMENT: ⚠ IL INDIQUE LES COMPOSANTS CRITIQUES DE SÉCURITÉ. POUR MAINTENIR LE DEGRÉ DE SÉCURITÉ DE L'APPAREIL, NE REMPLACER QUE DES PIÈCES RECOMMANDÉES PAR LE FABRICANT

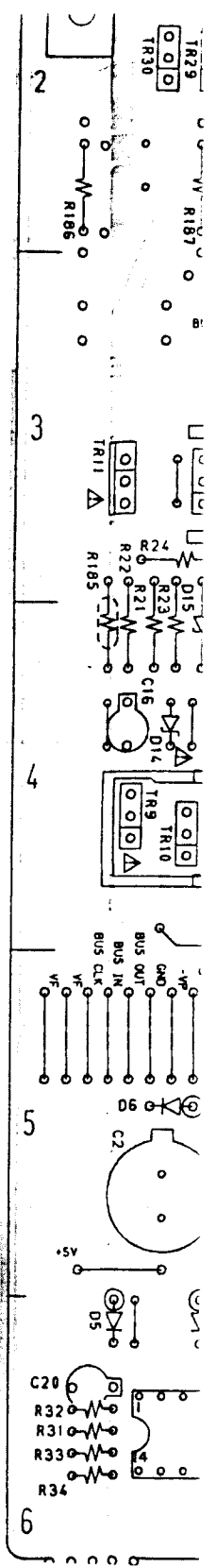

C2,3  
C4  
C3

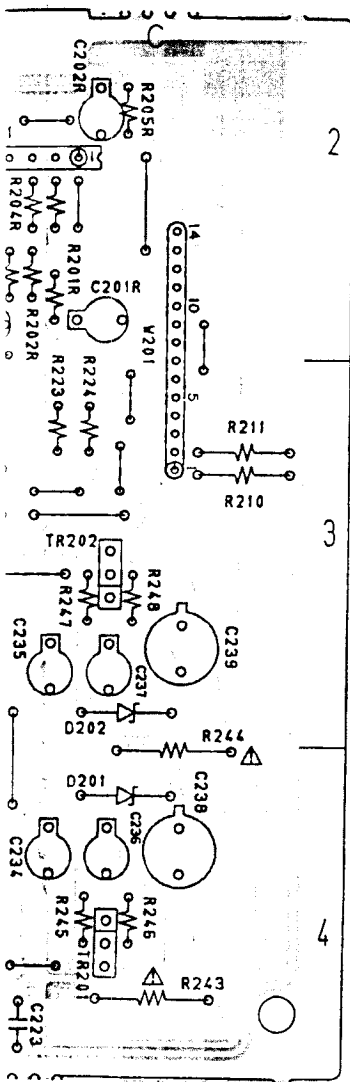

...ENDING ON MODEL NUMBER.  
...DIAGRAMS FOR PERTAINING

...COMPONENTS FOR CONTINUED SAFETY.  
...COMPONENTS ONLY WITH MANUFACTURER'S

...POSANTS CRITIQUES DE SÉCURITÉ.  
...DE SÉCURITÉ DE L'APPAREIL.  
...DES RECOMMANDÉES PAR LE FABRICANT

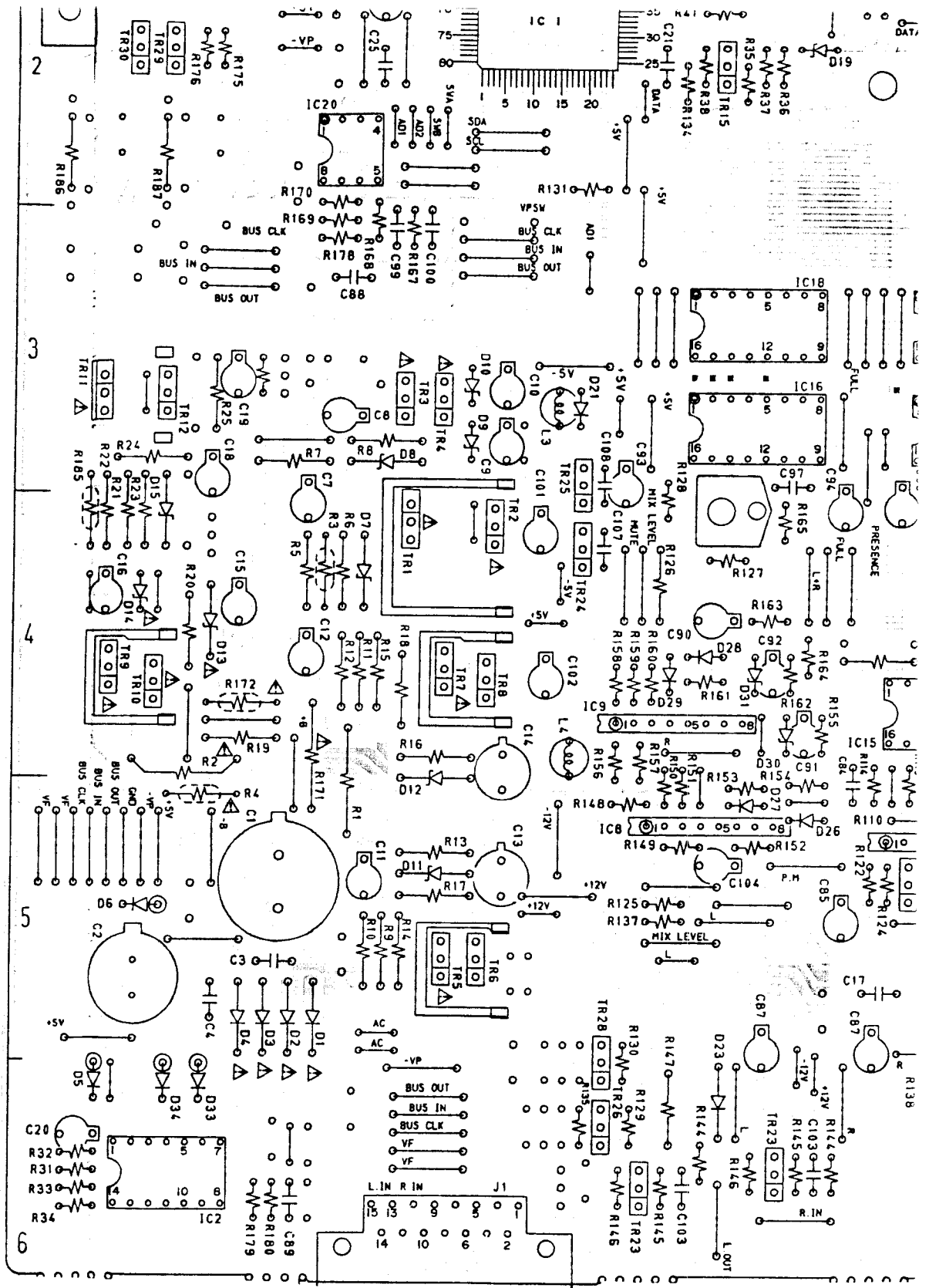

MAIN PCB D3

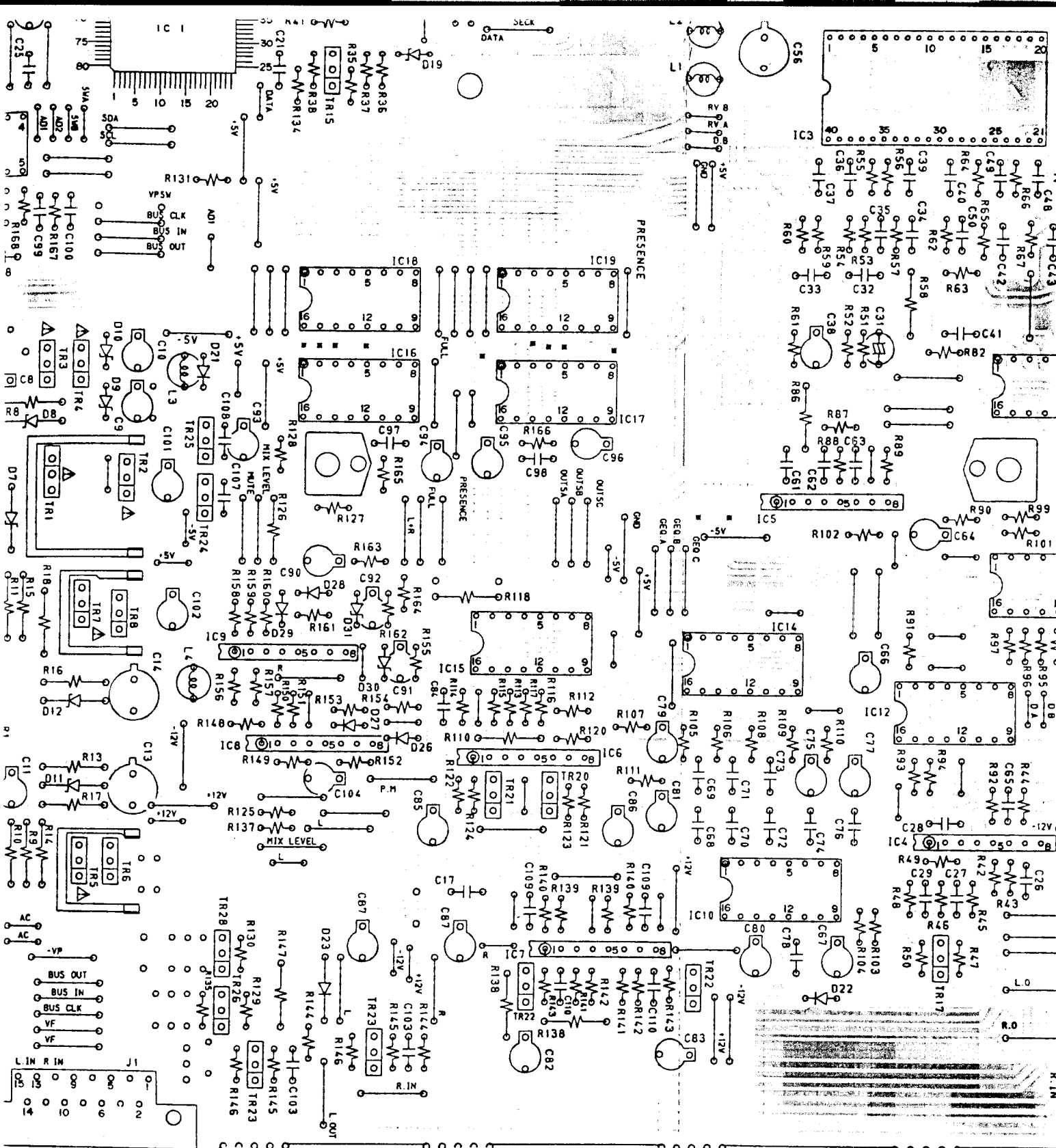

MAIN PCB D3016A5010

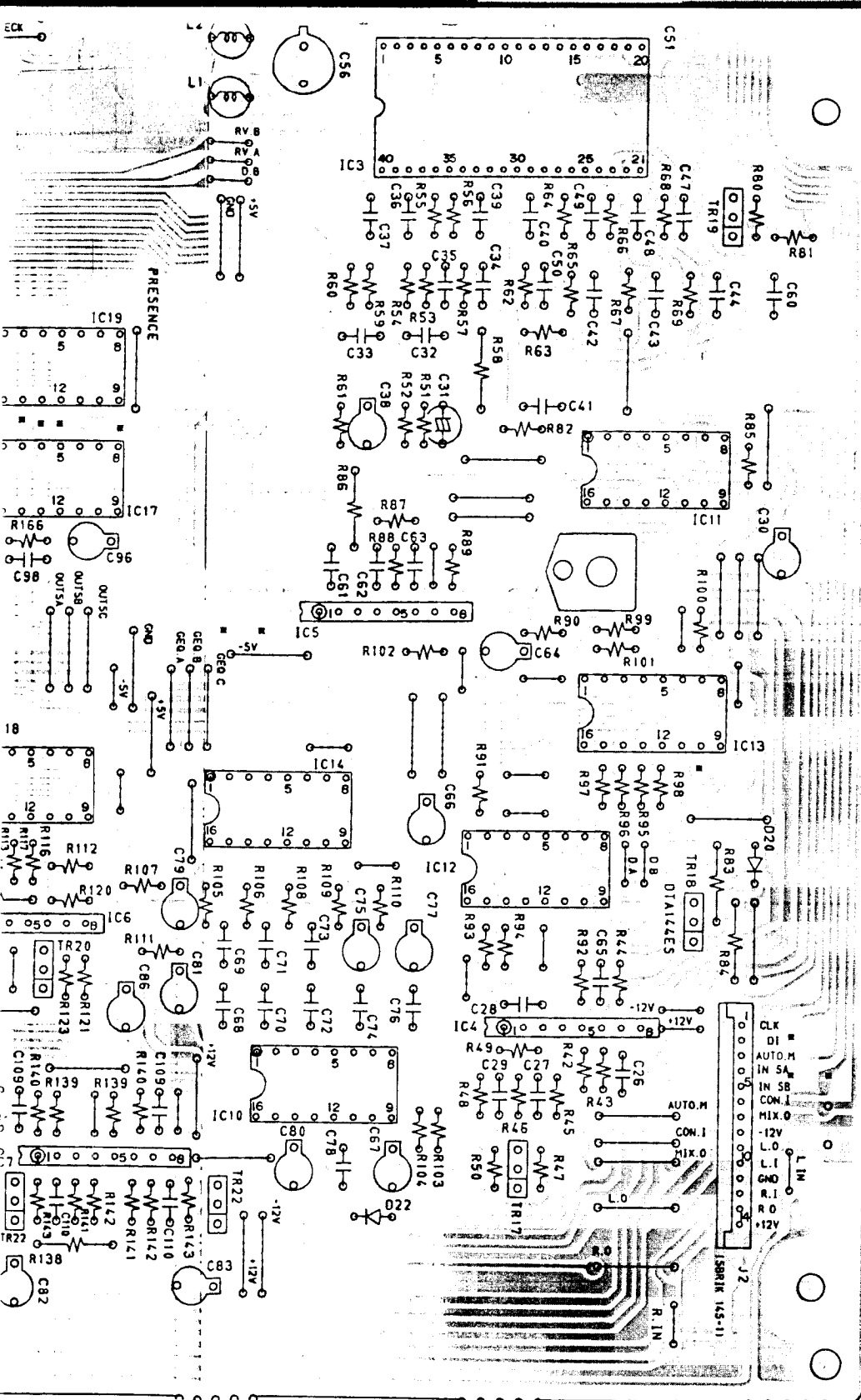

- IC12 ..... A,B5
- IC13 ..... A4
- IC14 ..... C,B4
- IC15 ..... C4
- IC16 ..... D3
- IC17 ..... C3
- IC18 ..... D3
- IC19 ..... C3
- IC20 ..... E2

- CONNECTORS**
- J1 ..... E6
  - J2 ..... A5,6
  - J3 ..... E1
  - J4 ..... C1
  - J5 ..... B1

- TRANSISTORS**
- TR1 ..... E4
  - TR2 ..... E4
  - TR3 ..... E3
  - TR4 ..... E3
  - TR5 ..... E5
  - TR6 ..... E5
  - TR7 ..... E4
  - TR8 ..... E4
  - TR9 ..... F4
  - TR10 ..... F4
  - TR11 ..... F3
  - TR12 ..... F3
  - TR15 ..... D2
  - TR16 ..... B1
  - TR17 ..... B5,6
  - TR18 ..... A5
  - TR19 ..... A2
  - TR20 ..... C5
  - TR21 ..... C5
  - TR22 ..... C6
  - TR23 ..... D6
  - TR24 ..... E4
  - TR25 ..... E3
  - TR26 ..... E6
  - TR28 ..... E5,6
  - TR29 ..... F2
  - TR30 ..... F2
  - TR31 ..... F2
  - TR32 ..... F2

16A5010

A

B

C

D

MAIN POWER PCB A5013A501H FUSE PCB A5013A501G

1  
2  
3  
4  
5  
6

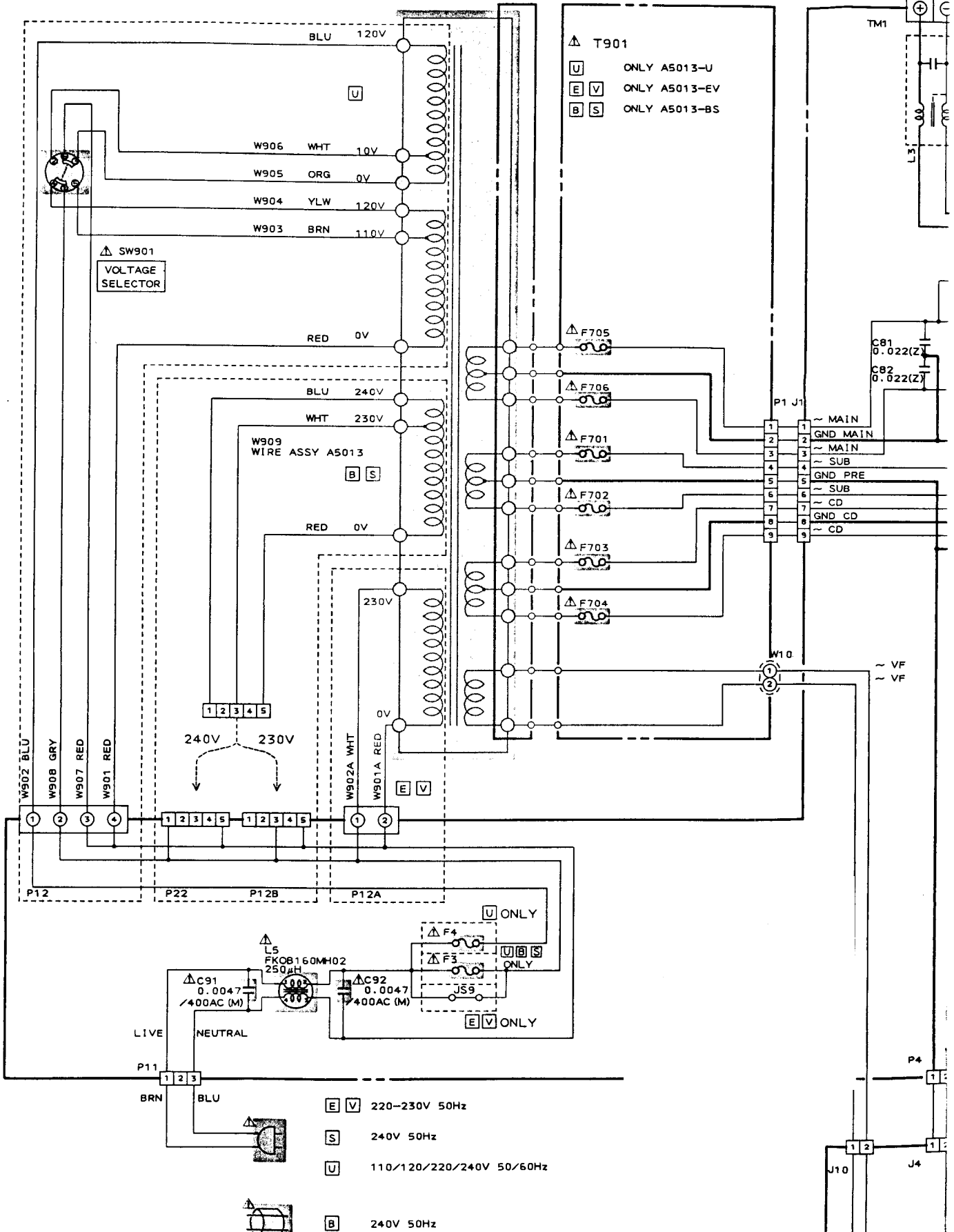

- △ T901
- U ONLY A5013-U
- E V ONLY A5013-EV
- B S ONLY A5013-BS

E V	220-230V 50Hz
S	240V 50Hz
U	110/120/220/240V 50/60Hz
B	240V 50Hz

S

TM1

P1 J1

W10

~ VF  
~ VF

C81  
0.022(Z)  
C82  
0.022(Z)

1 ~ MAIN  
2 ~ MAIN  
3 ~ SUB  
4 ~ GND PRE  
5 ~ SUB  
6 ~ CD  
7 ~ GND CD  
8 ~ CD  
9

P4

J10

J4



C

D

E

F

A5013A501H FUSE PCB A5013A501G

- △ T901
- U ONLY A5013-U
  - E V ONLY A5013-EV
  - B S ONLY A5013-BS

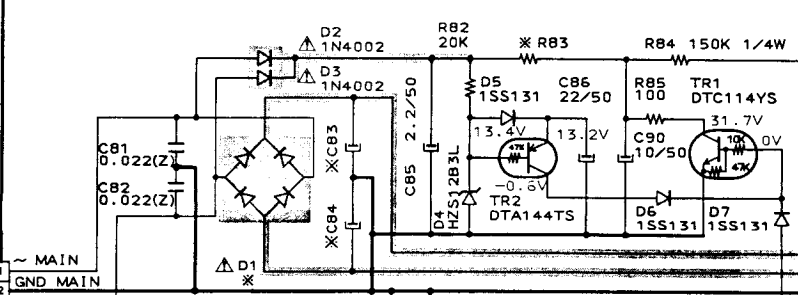
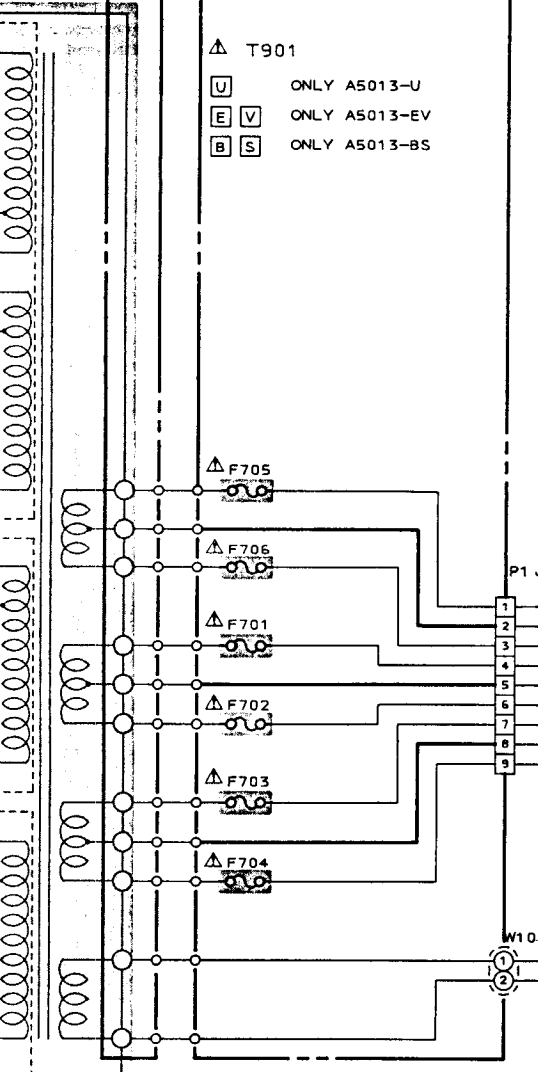
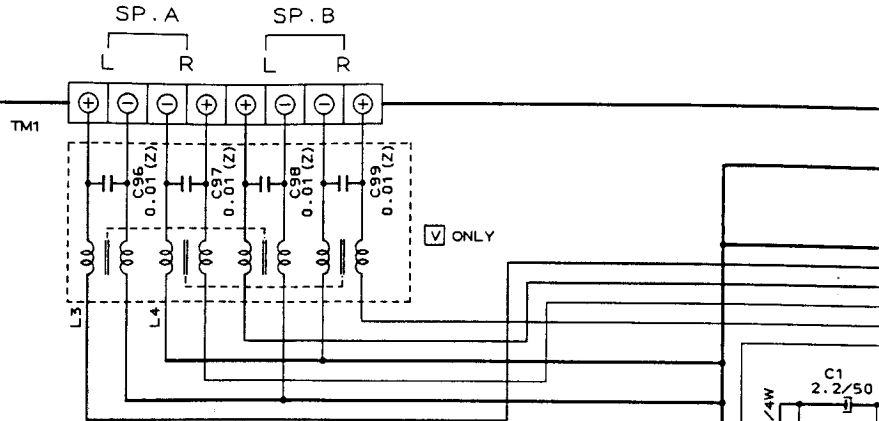

	PA-750	PA-950
C83	3300/45	4700/50
C84	3300/45	4700/50
D1	RBV-402	RBV-602
R4	510	430
R7	2.2K	3.3K
R8	2.2K	3.3K
R54	510	430
R57	2.2K	3.3K
R58	2.2K	3.3K
R83	47K	51K

**RTV servis Horvat**  
 Kešinci, 31402 Semeljci  
 031-856-139  
 031-856-637  
 098-788-319  
[rtv-servis-horvat@os.tel.hr](mailto:rtv-servis-horvat@os.tel.hr)  
 Croatia

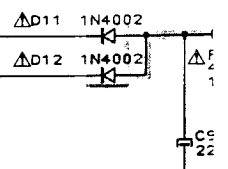
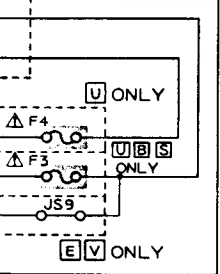
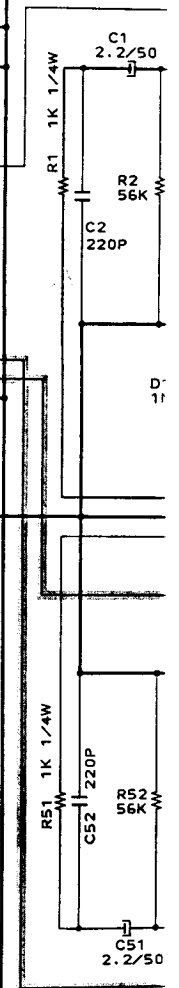

POWER SU

100V 50Hz  
 110V 60Hz  
 220/220/240V 50/60Hz  
 230V 50Hz

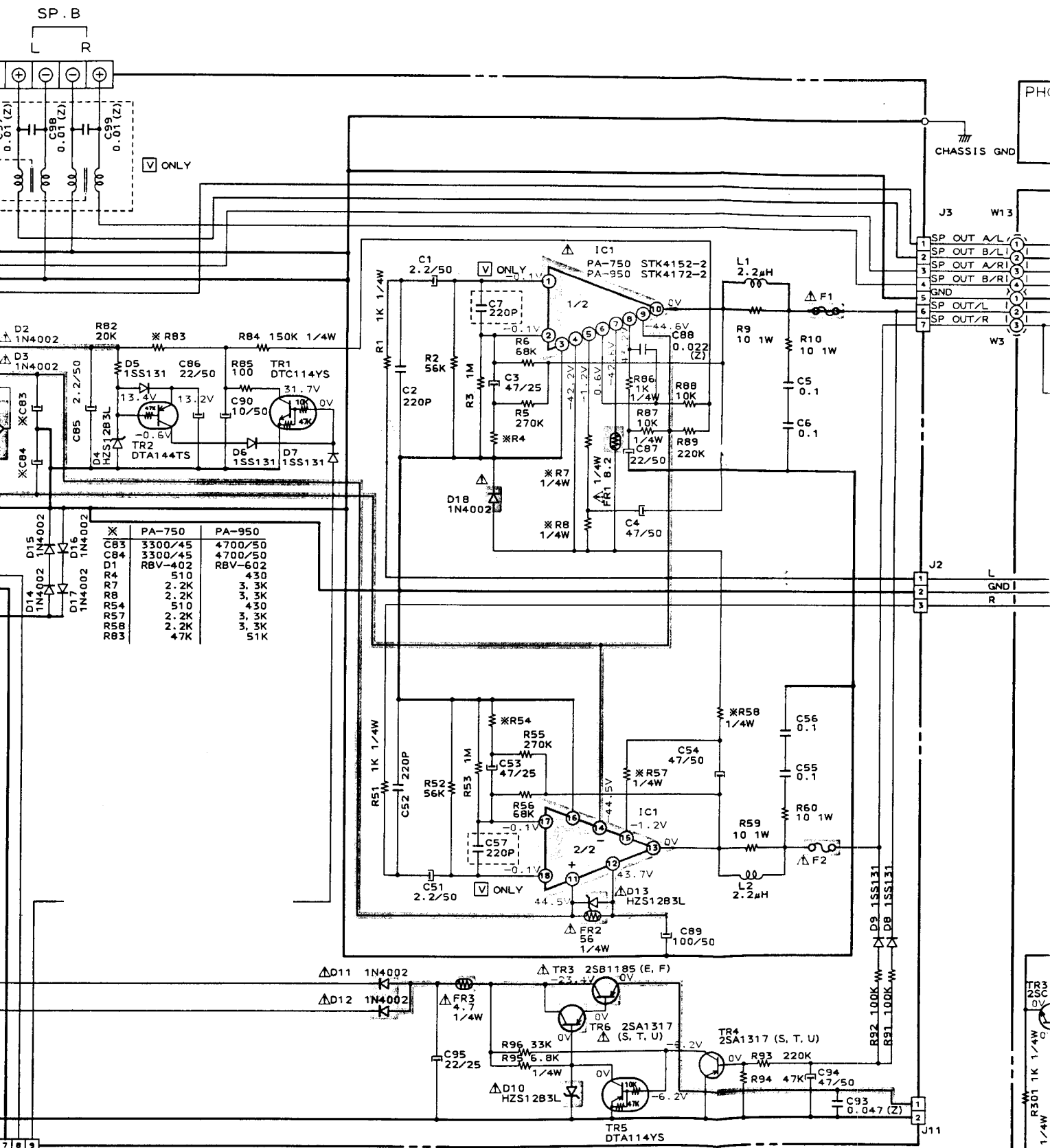

POWER SUPPLY / MAIN AMP PCB A5013A501A

	PA-750	PA-950
C83	3300/45	4700/50
C84	3300/45	4700/50
D1	RBV-402	RBV-602
R4	510	430
R7	2.2K	3, 3K
R8	2.2K	3, 3K
R54	510	430
R57	2.2K	3, 3K
R58	2.2K	3, 3K
R83	47K	51K



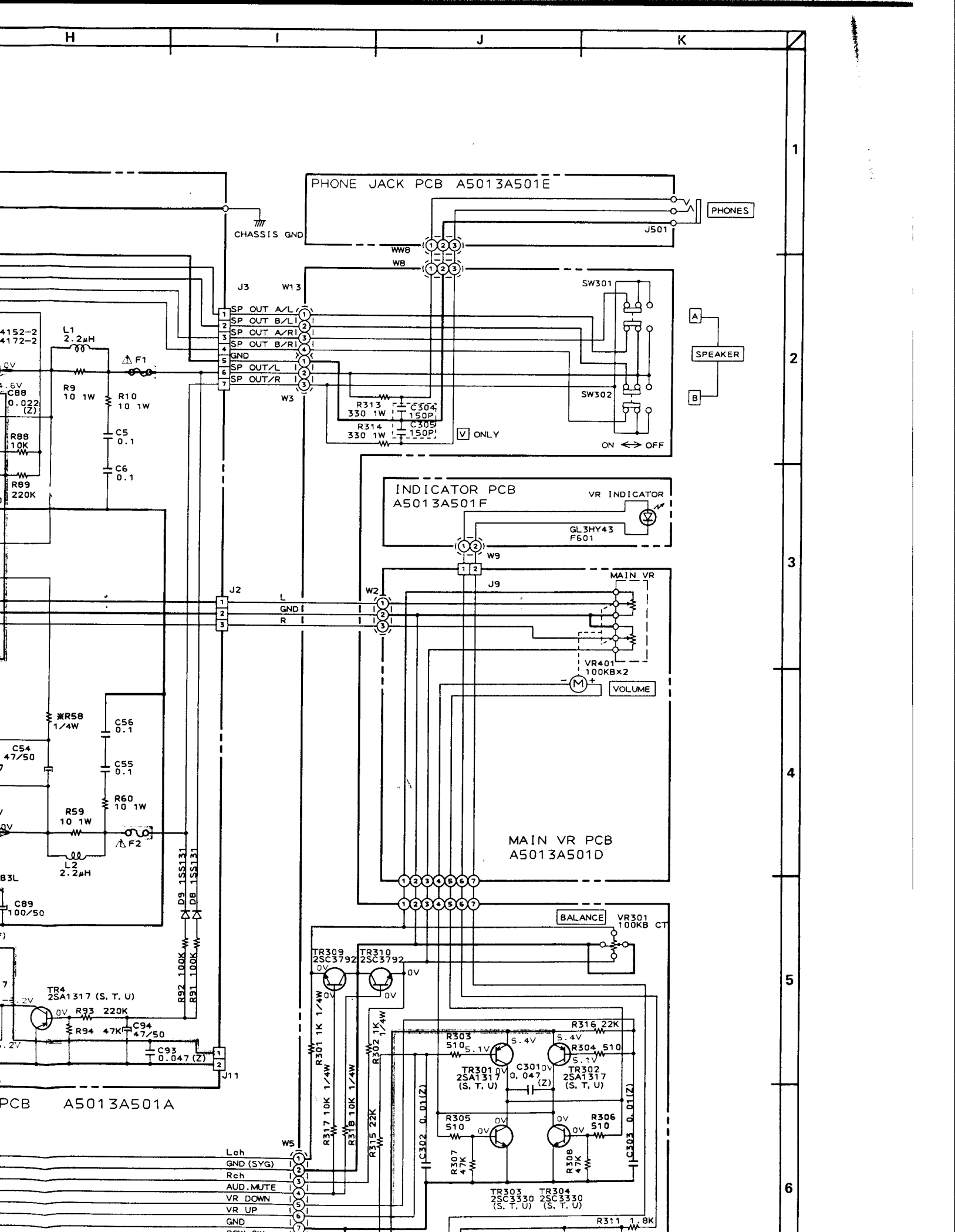

3  
4  
5  
6  
7  
8

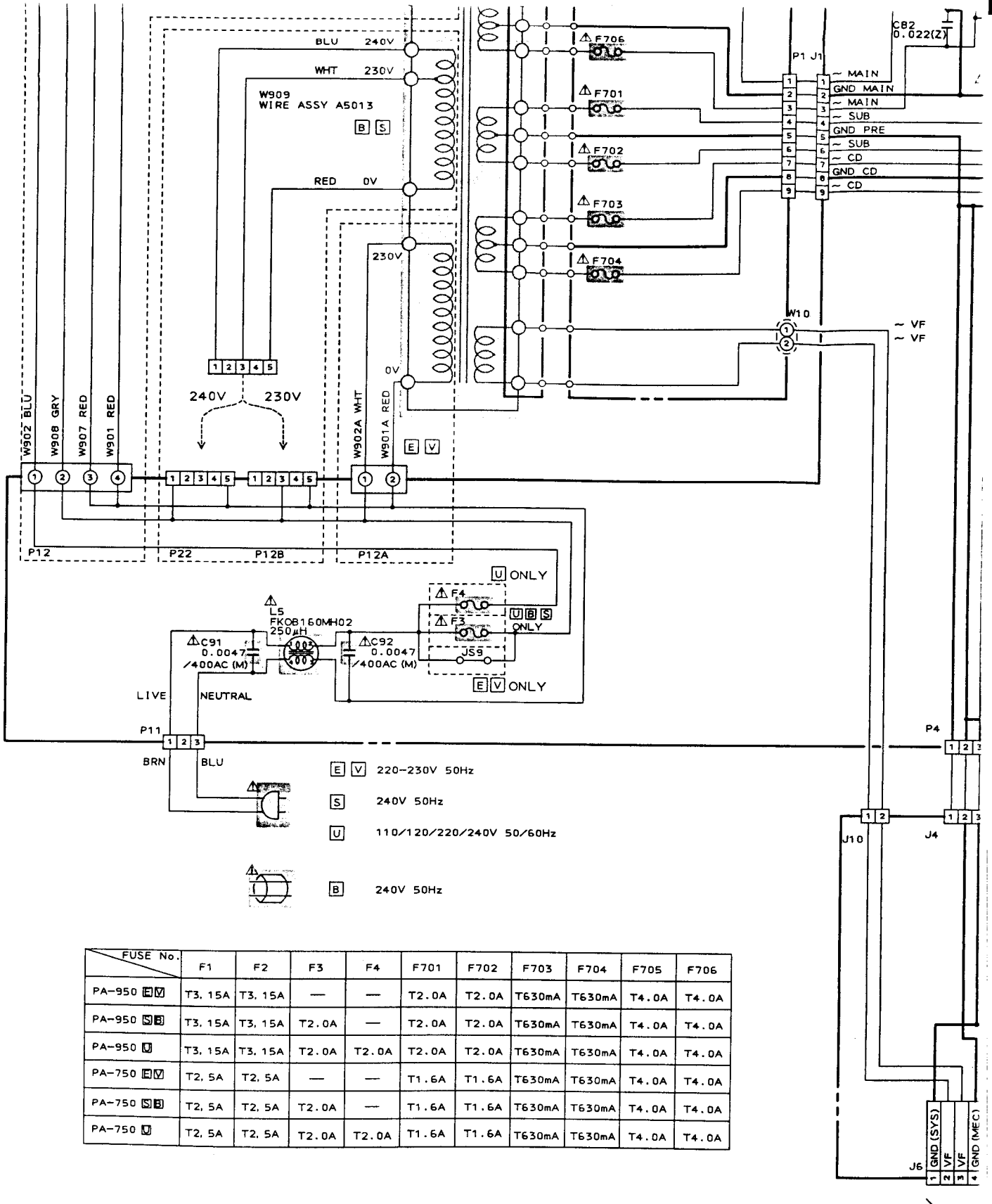

FUSE No.	F1	F2	F3	F4	F701	F702	F703	F704	F705	F706
PA-950	T3, 15A	T3, 15A	—	—	T2.0A	T2.0A	T630mA	T630mA	T4.0A	T4.0A
PA-950	T3, 15A	T3, 15A	T2.0A	—	T2.0A	T2.0A	T630mA	T630mA	T4.0A	T4.0A
PA-950	T3, 15A	T3, 15A	T2.0A	T2.0A	T2.0A	T2.0A	T630mA	T630mA	T4.0A	T4.0A
PA-750	T2, 5A	T2, 5A	—	—	T1.6A	T1.6A	T630mA	T630mA	T4.0A	T4.0A
PA-750	T2, 5A	T2, 5A	T2.0A	—	T1.6A	T1.6A	T630mA	T630mA	T4.0A	T4.0A
PA-750	T2, 5A	T2, 5A	T2.0A	T2.0A	T1.6A	T1.6A	T630mA	T630mA	T4.0A	T4.0A

B (POWER SUPPLY) LINE  
 AUDIO SIGNAL LINE (L-CH)

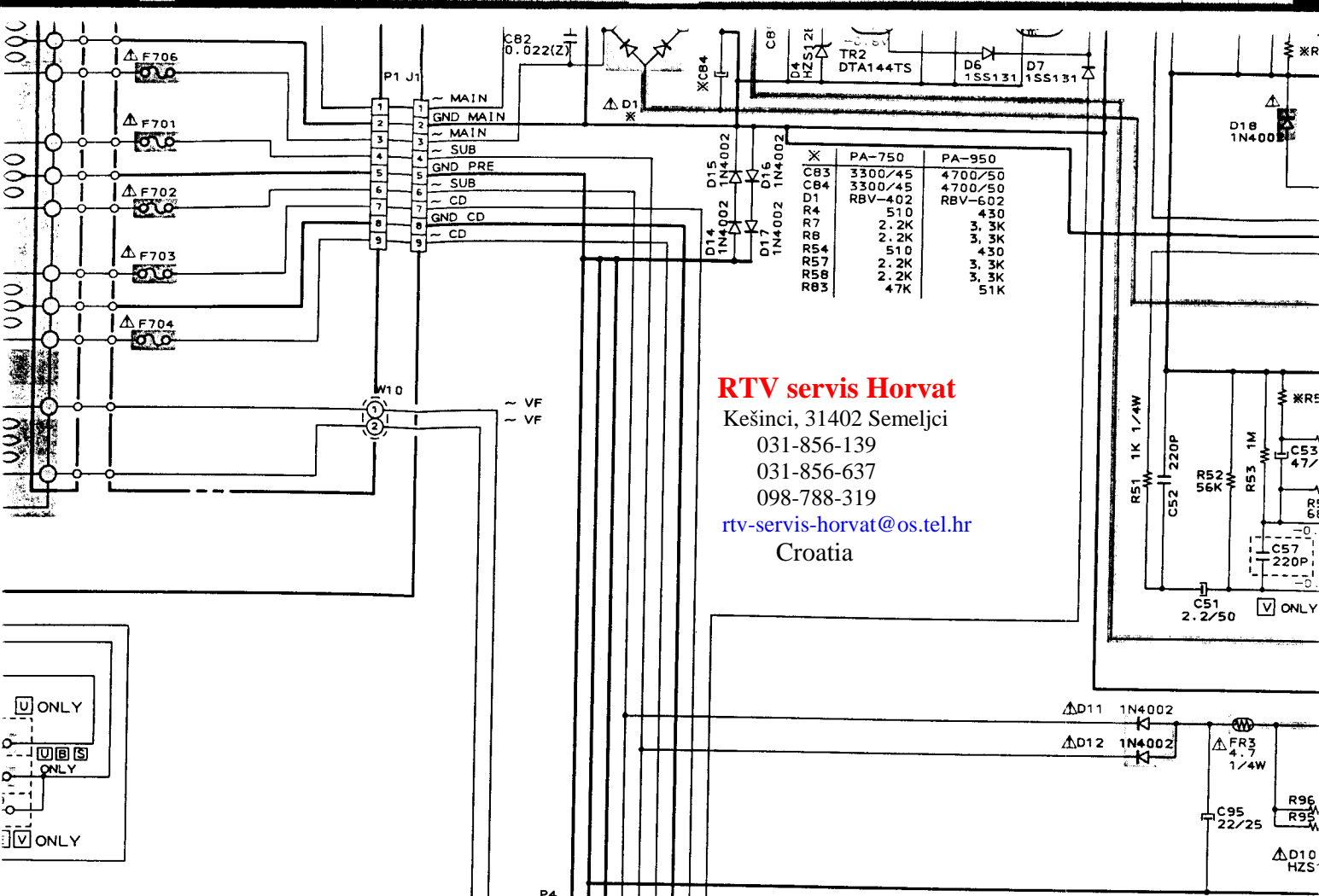

**RTV servis Horvat**

Kešinci, 31402 Semeljci

031-856-139

031-856-637

098-788-319

[rtv-servis-horvat@os.tel.hr](mailto:rtv-servis-horvat@os.tel.hr)

Croatia

	PA-750	PA-950
C83	3300/45	4700/50
C84	3300/45	4700/50
D1	RBV-402	RBV-602
R4	510	430
R7	2.2K	3.3K
R8	2.2K	3.3K
R54	510	430
R57	2.2K	3.3K
R58	2.2K	3.3K
R83	47K	51K

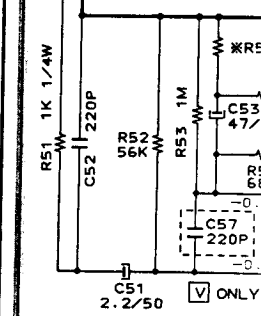
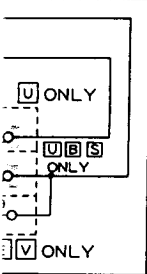

0V 50/60Hz

	F703	F704	F705	F706
0A	T630mA	T630mA	T4.0A	T4.0A
0A	T630mA	T630mA	T4.0A	T4.0A
0A	T630mA	T630mA	T4.0A	T4.0A
6A	T630mA	T630mA	T4.0A	T4.0A
6A	T630mA	T630mA	T4.0A	T4.0A
6A	T630mA	T630mA	T4.0A	T4.0A

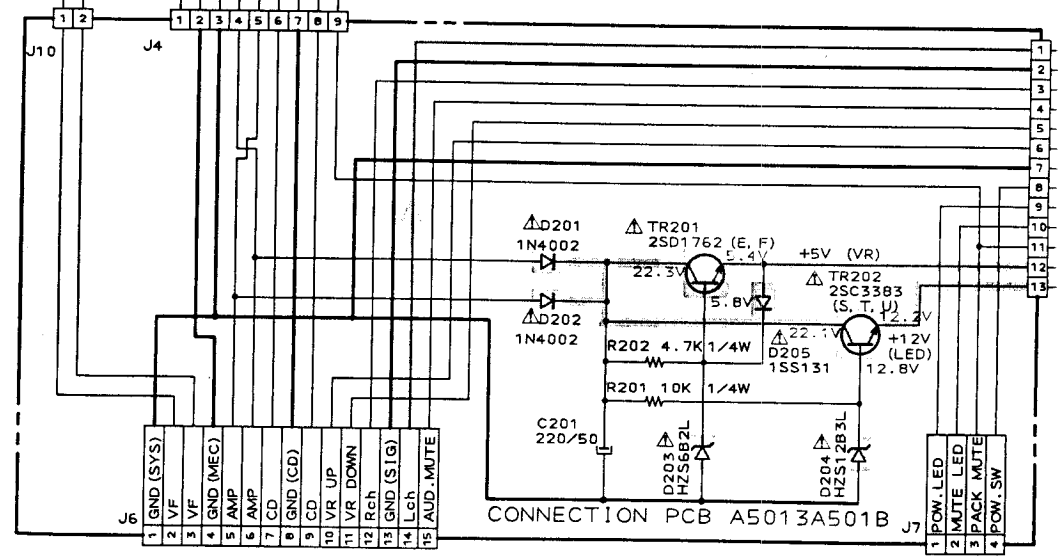

B (POWER SUPPLY) LINE  
AUDIO SIGNAL LINE (L-CH)

FROM MODEL TP-750

WARNING: AND IN COMPONENTS FOR REPLACE SAFELY ONLY WITH MANUFACTURER'S PARTS  
AVERTISSEMENT: ET COMPOSANTS C POUR MAINTENIR DE L'APPAREIL PIÈCES RECOM

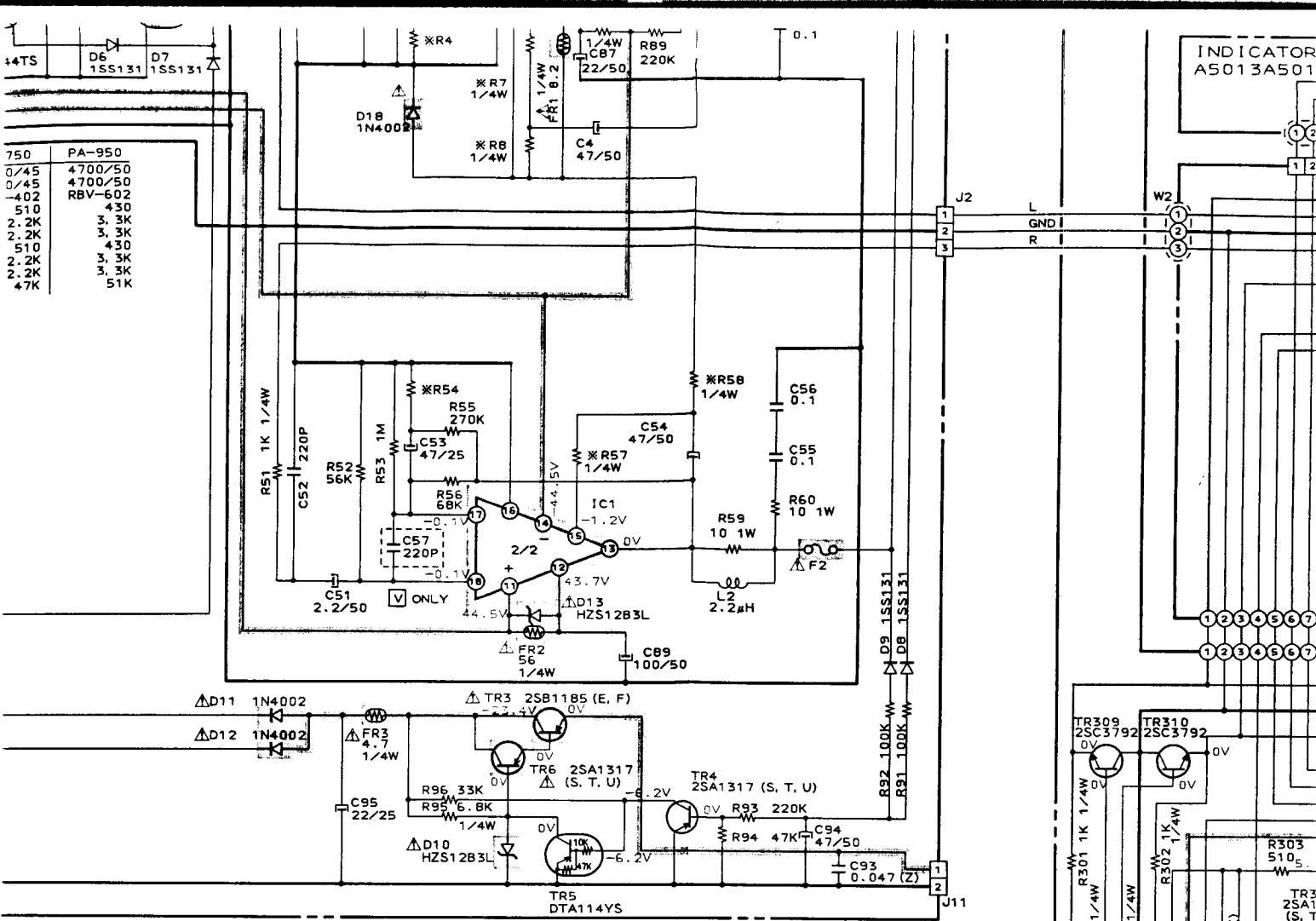

POWER SUPPLY / MAIN AMP PCB A5013A501A

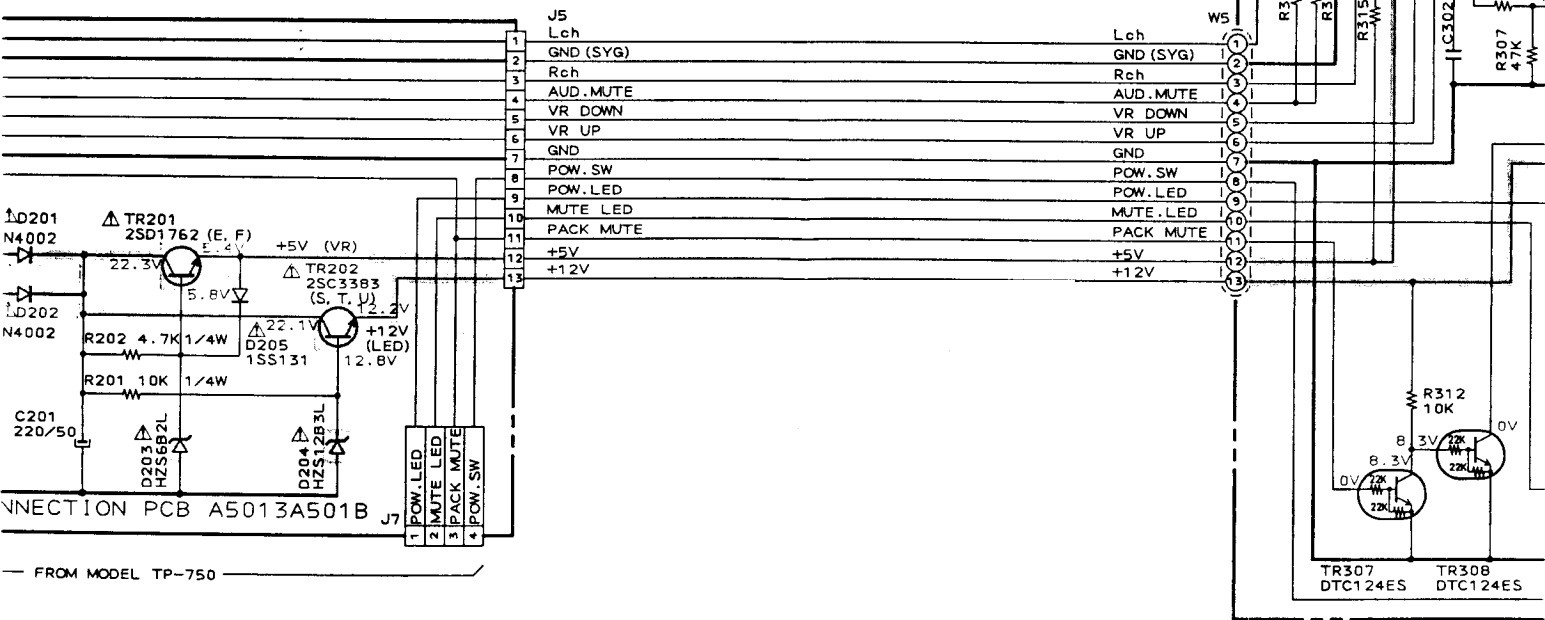

CONTROL PCB

WARNING:  $\Delta$  AND  $\nabla$  INDICATE SAFETY CRITICAL COMPONENTS FOR CONTINUED SAFETY. REPLACE SAFETY CRITICAL COMPONENTS ONLY WITH MANUFACTURER'S RECOMMENDED PARTS.

AVERTISSEMENT:  $\Delta$  ET  $\nabla$  ILS INDIQUENT LES COMPOSANTS CRITIQUES DE SÉCURITÉ. POUR MAINTENIR LE DEGRÉ DE SÉCURITÉ DE L'APPAREIL, NE REMPLACER QUE DES PIÈCES RECOMMANDÉES PAR LE FABRICANT.

NOTE: UNLESS OTHERWISE SPECIFIED ALL RESISTORS IN OHMS (J) ALL CAPACITORS IN  $\mu$ F (P=PF) 50V (J) ALL ELECTROLYTIC CAPACITORS IN  $\mu$ F/WV(M)

INDICATED VOLTAGES WERE MEASURED WHEN NO SIGNAL WAS BEING INPUT.

PA-750,  
POWER  
SCHEMA

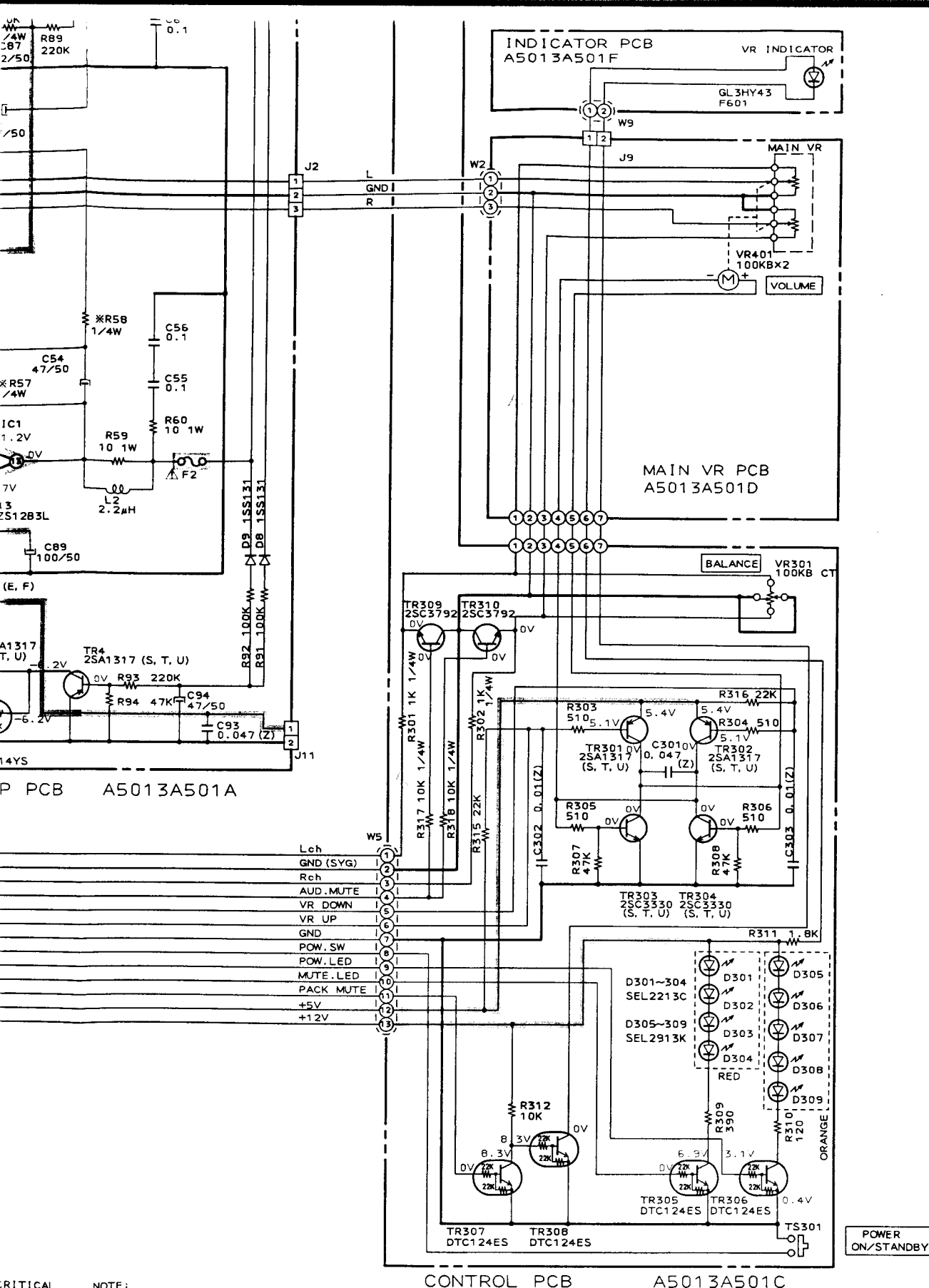

3  
4  
5  
6  
7  
8

CRITICAL  
FETY,  
COMPONENTS  
COMMENDED

NOTE:  
UNLESS OTHERWISE SPECIFIED  
ALL RESISTORS IN OHMS 1/4W (J)  
ALL CAPACITORS IN  $\mu$ F (P-PF) 50V (J)  
ALL ELECTROLYTIC CAPACITORS IN  $\mu$ F/WV (M)

INDICATED VOLTAGES WERE MEASURED  
WHEN NO SIGNAL WAS BEING INPUT

LES  
CURITÉ,  
SÉCURITÉ  
QUE DES  
FABRICANT

PA-750/950  
POWER SUPPLY & MAIN AMP  
SCHEMATIC DIAGRAM  
No. 8-5 A501302M  
A1

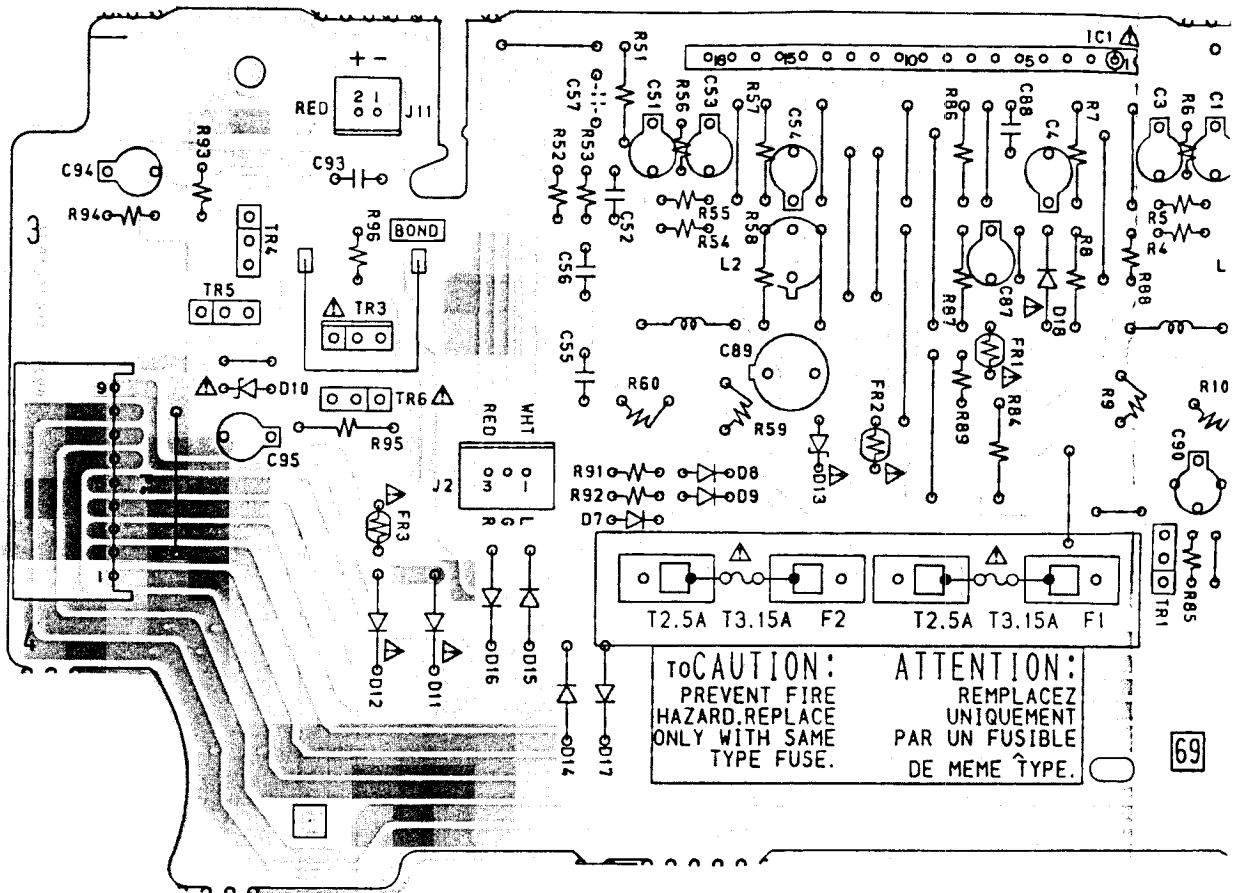

POWER SUPPLY / MAIN AMP PCB A5013A501

NOTE : PARTS DIFFER DEPENDING ON MODEL NUMB  
REFER TO SCHEMATIC DIAGRAMS FOR PERTAIN  
PARTS INFORMATION.

WARNING: ⚠ INDICATES SAFETY CRITICAL COMPONENTS FOR CONTINUED SAFET  
REPLACE SAFETY CRITICAL COMPONENTS ONLY WITH MANUFACTUREF  
RECOMMENDED PARTS

AVERTISSEMENT: ⚠ IL INDIQUE LES COMPOSANTS CRITIQUES DE SÉCURITÉ.  
POUR MAINTENIR LE DEGRÉ DE SÉCURITÉ DE L'APPAREIL.  
NE REMPLACER QUE DES PIÈCES RECOMMANDEES PAR LE FABRICANT

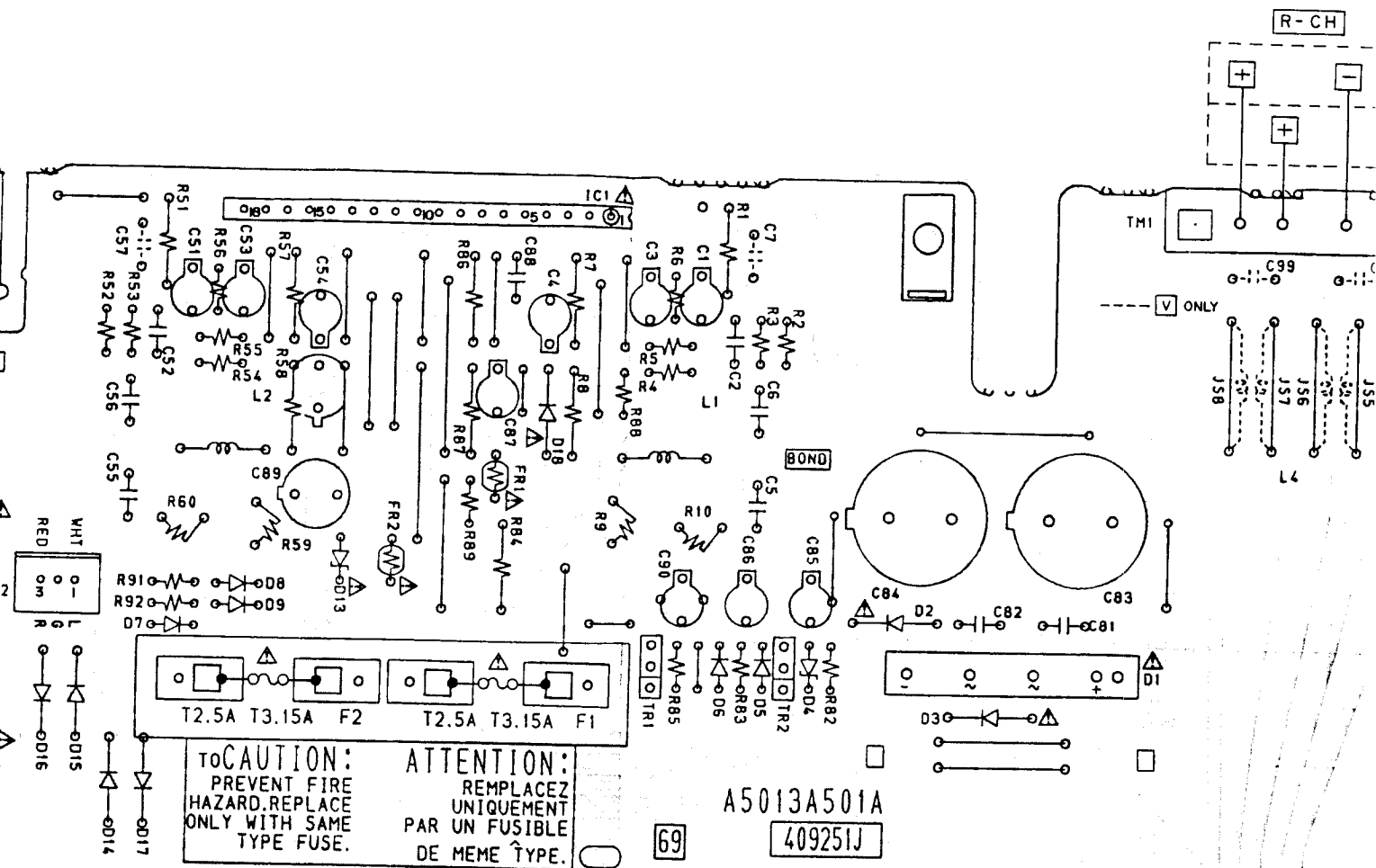

**POWER SUPPLY / MAIN AMP PCB A5013A501A**

NOTE : PARTS DIFFER DEPENDING ON MODEL NUMBER. REFER TO SCHEMATIC DIAGRAMS FOR PERTAINING PARTS INFORMATION.

WARNING:  $\Delta$  INDICATES SAFETY CRITICAL COMPONENTS. FOR CONTINUED SAFETY, REPLACE SAFETY CRITICAL COMPONENTS ONLY WITH MANUFACTURER'S RECOMMENDED PARTS.

AVERTISSEMENT:  $\Delta$  IL INDIQUE LES COMPOSANTS CRITIQUES DE SÉCURITÉ. POUR MAINTENIR LE DEGRÉ DE SÉCURITÉ DE L'APPAREIL, NE REMPLACER QUE DES PIÈCES RECOMMANDÉES PAR LE FABRICANT

**CAUTION:**  
PREVENT FIRE HAZARD. REPLACE ONLY WITH SAME TYPE FUSE.

**ATTENTION:**  
REPLACEZ UNIQUEMENT PAR UN FUSIBLE DE MEME TYPE.

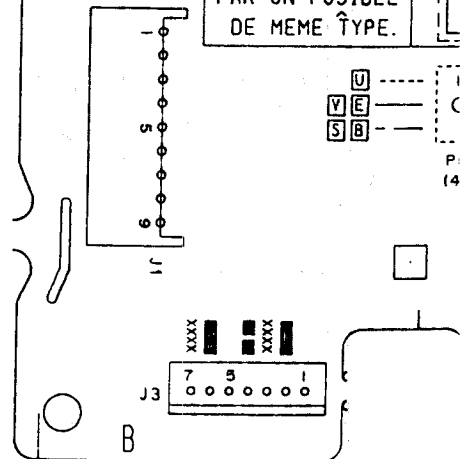

SPEAKER

R-CH

L-CH

A

B

TM1

ONLY

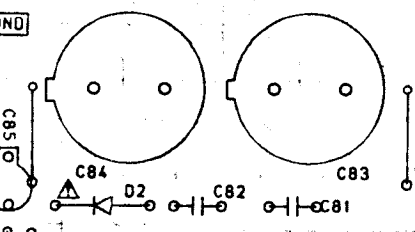
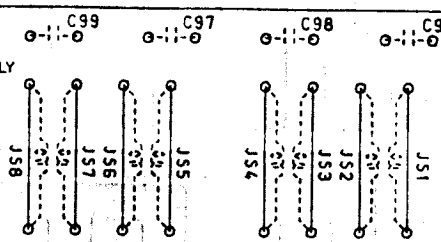

A501A  
09251J

P11

C91

L5

C92

TO CAUTION:  
PREVENT FIRE  
HAZARD, REPLACE  
ONLY WITH SAME  
TYPE FUSE.

ATTENTION:  
REPLACEZ  
UNIQUEMENT  
PAR UN FUSIBLE  
DE MEME TYPE.

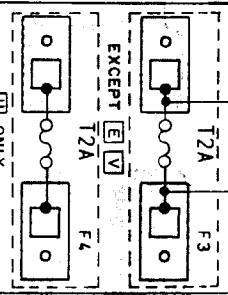

ONLY

ONLY

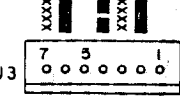
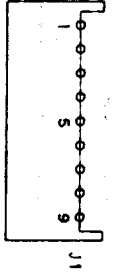
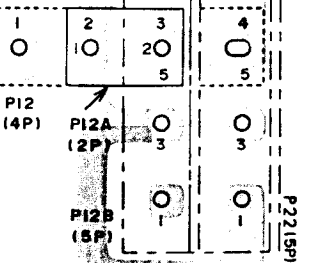

B

A

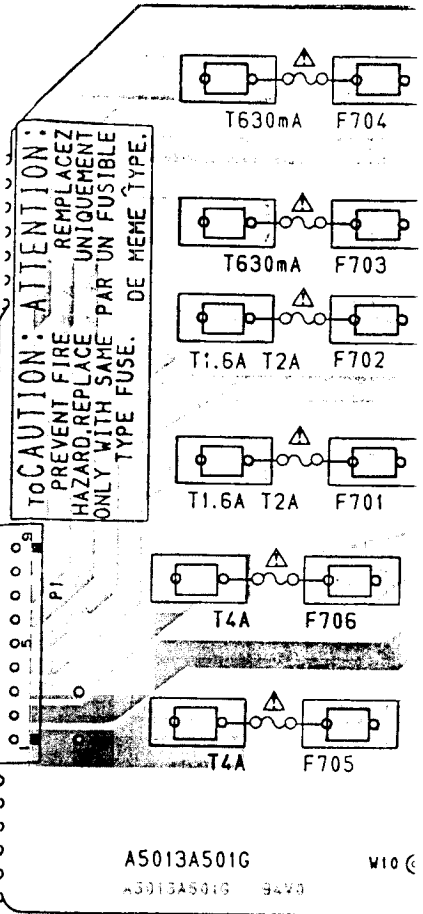

TO CAUTION: ATTENTION:  
PREVENT FIRE HAZARD, REPLACE ONLY WITH SAME TYPE FUSE.  
REPLACEZ UNIQUEMENT PAR UN FUSIBLE DE MEME TYPE.

A5013A501G

W10

A5013A501G 9249

FUSE PCB A5013A501G

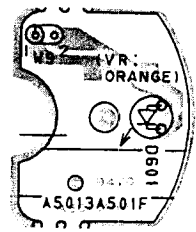

INDICATOR PCB  
A5013A501F

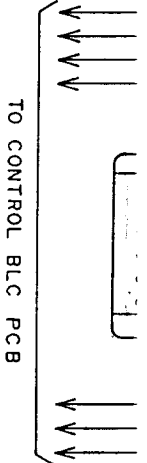

MAI



A  
B

3

4

5

6

**TO CAUTION: ATTENTION:**  
 PREVENT FIRE HAZARD, REPLACE ONLY WITH SAME TYPE FUSE.  
 REMPLACER UNIQUEMENT PAR UN FUSIBLE DE MEME TYPE.

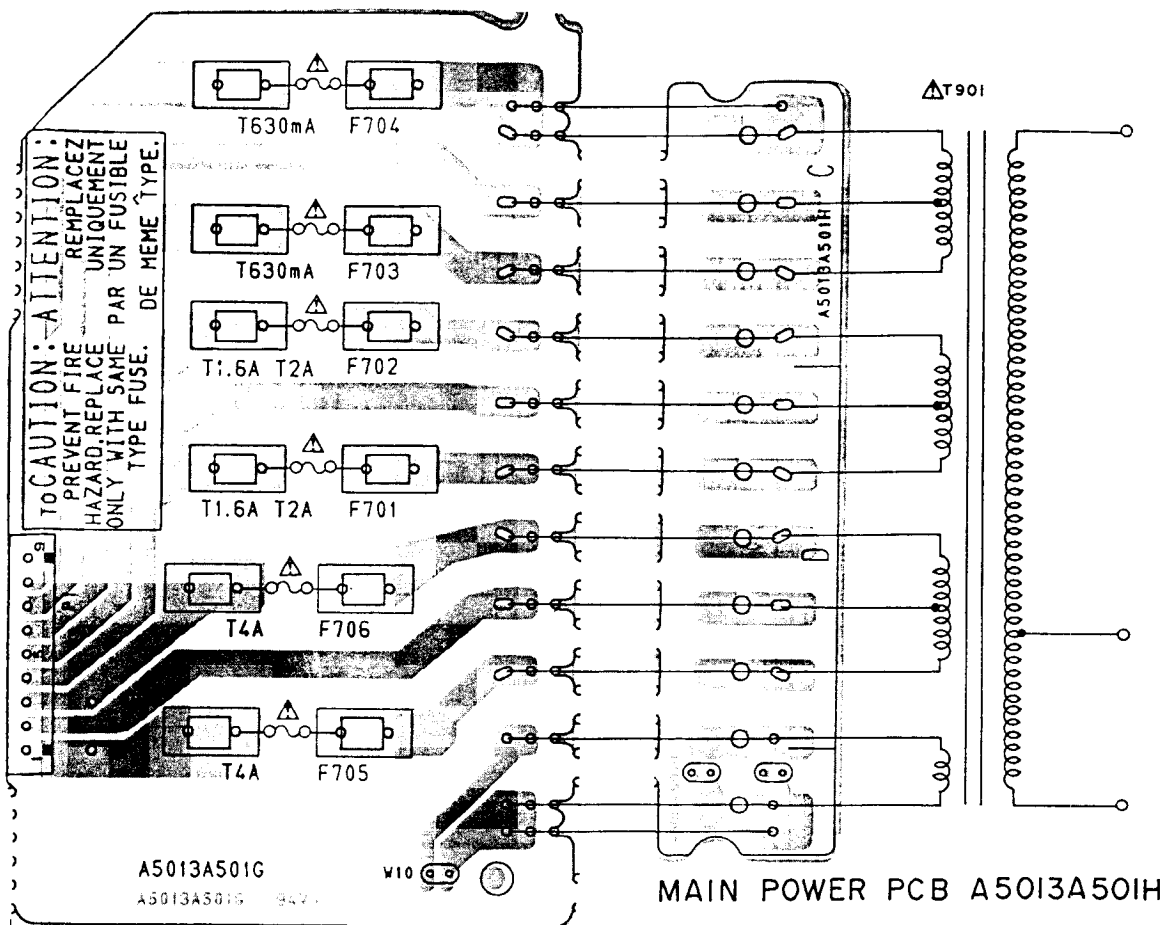

MAIN POWER PCB A5013A50IH

FUSE PCB A5013A50IG

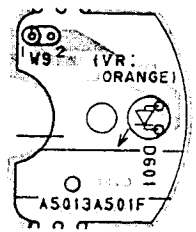

INDICATOR PCB A5013A501F

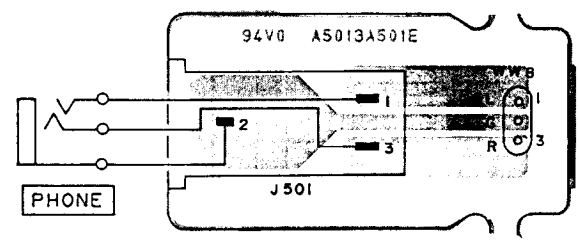

PHONE JACK PCB A5013A501E

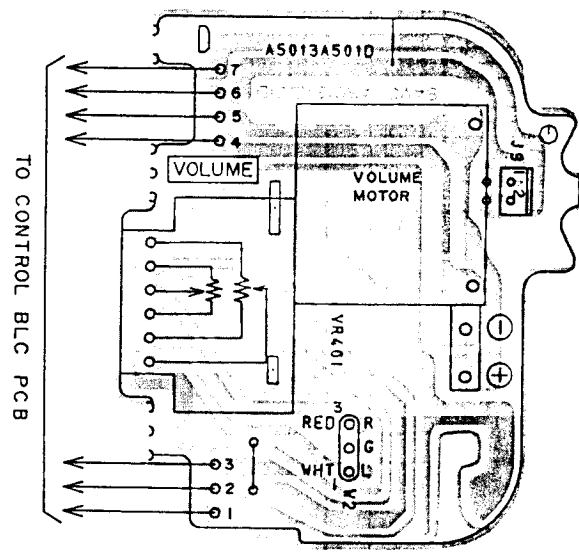

MAIN VR PCB A5013A501D

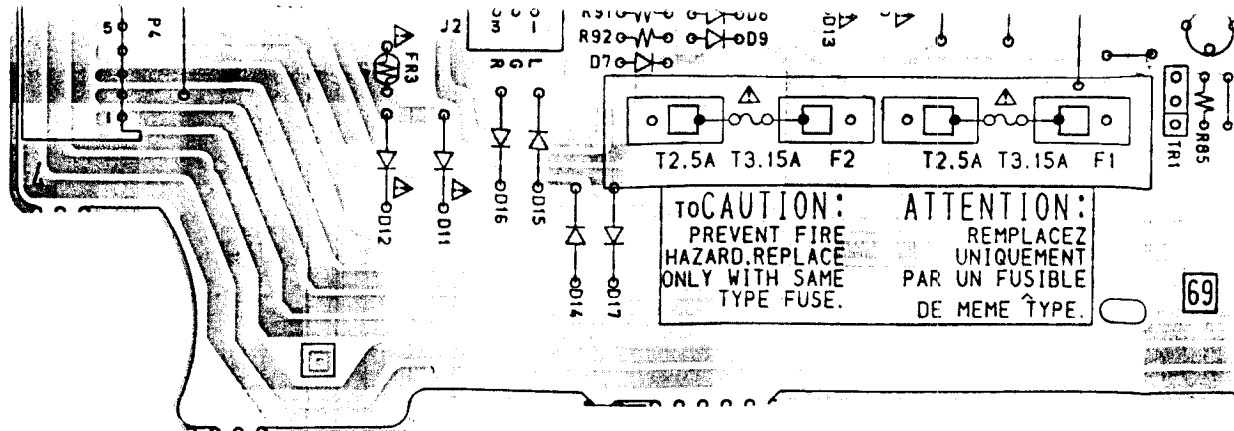

POWER SUPPLY / MAIN AMP PCB A5013A501.

NOTE : PARTS DIFFER DEPENDING ON MODEL NUMB  
REFER TO SCHEMATIC DIAGRAMS FOR PERTAIN  
PARTS INFORMATION.

WARNING:  $\Delta$  INDICATES SAFETY CRITICAL COMPONENTS FOR CONTINUED SAFET  
REPLACE SAFETY CRITICAL COMPONENTS ONLY WITH MANUFACTURER  
RECOMMENDED PARTS

AVERTISSEMENT:  $\Delta$  IL INDIQUE LES COMPOSANTS CRITIQUES DE SÉCURITÉ.  
POUR MAINTENIR LE DEGRÉ DE SÉCURITÉ DE L'APPAREIL.  
NE REMPLACER QUE DES PIÈCES RECOMMANDÉES PAR LE FABRICANT

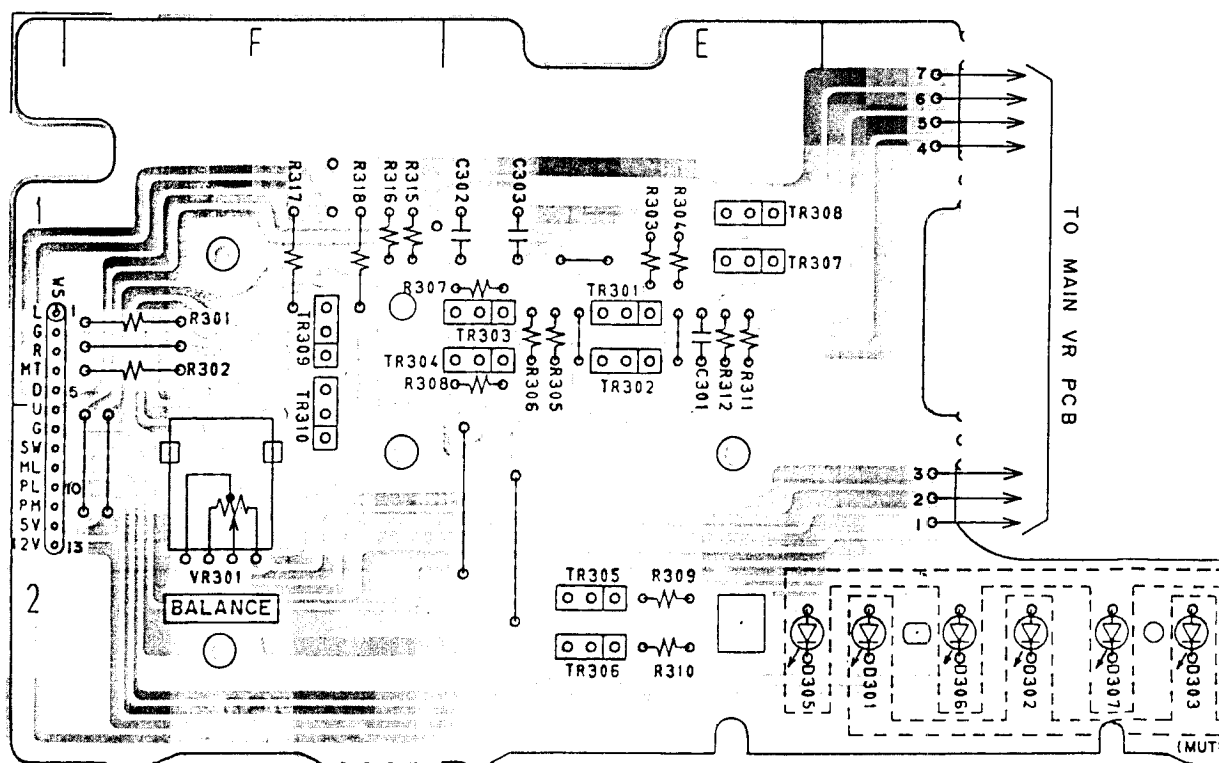

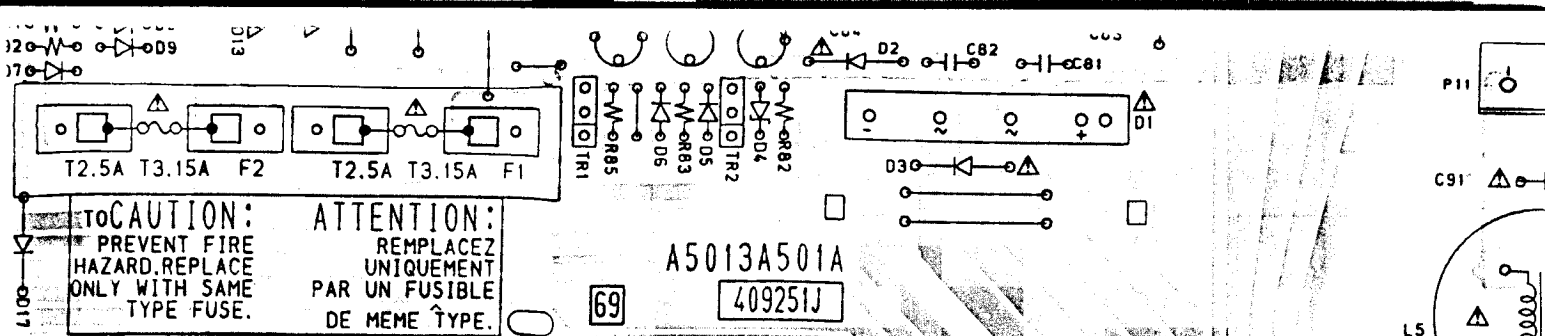

**SUPPLY / MAIN AMP PCB A5013A501A**

NOTE : PARTS DIFFER DEPENDING ON MODEL NUMBER. REFER TO SCHEMATIC DIAGRAMS FOR PERTAINING PARTS INFORMATION.

WARNING:  $\Delta$  INDICATES SAFETY CRITICAL COMPONENTS. FOR CONTINUED SAFETY, REPLACE SAFETY CRITICAL COMPONENTS ONLY WITH MANUFACTURER'S RECOMMENDED PARTS.

AVERTISSEMENT:  $\Delta$  IL INDIQUE LES COMPOSANTS CRITIQUES DE SÉCURITÉ. POUR MAINTENIR LE DEGRÉ DE SÉCURITÉ DE L'APPAREIL, NE REMPLACER QUE DES PIÈCES RECOMMANDÉES PAR LE FABRICANT.

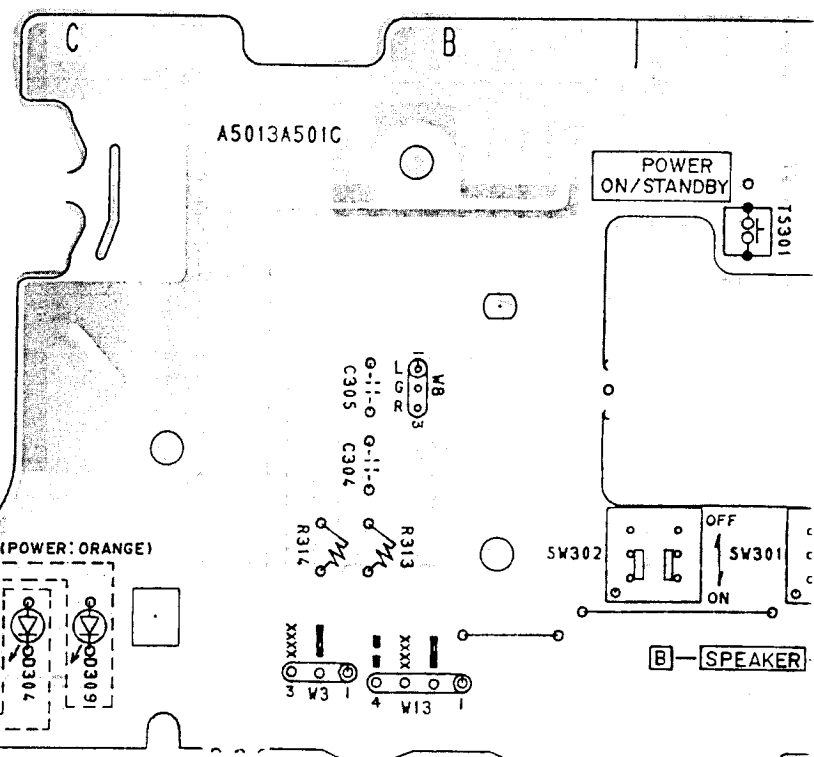
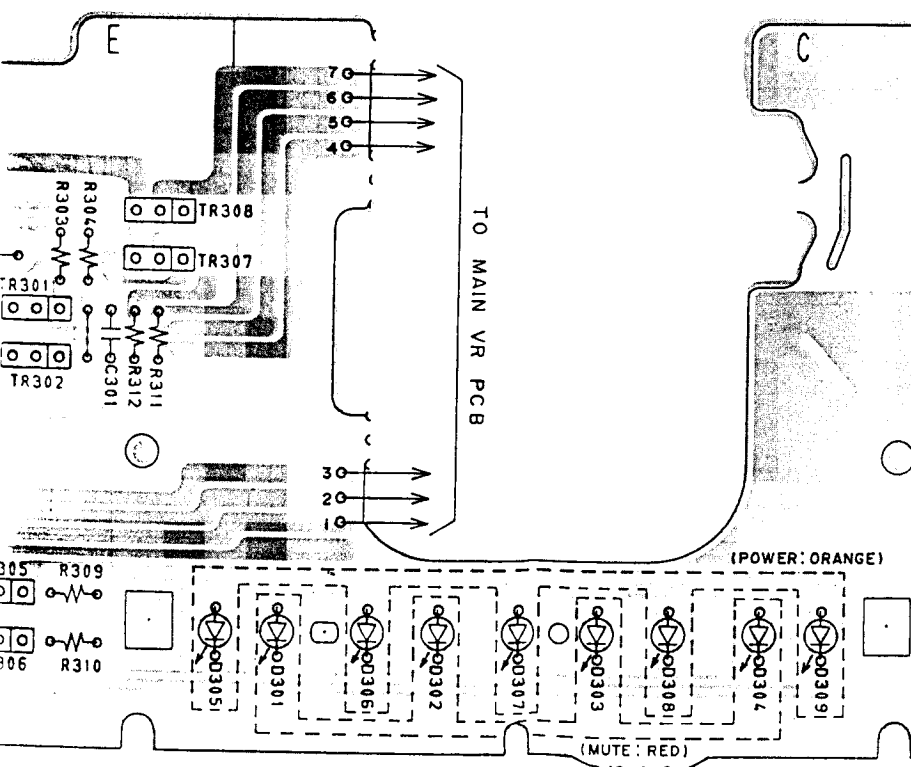
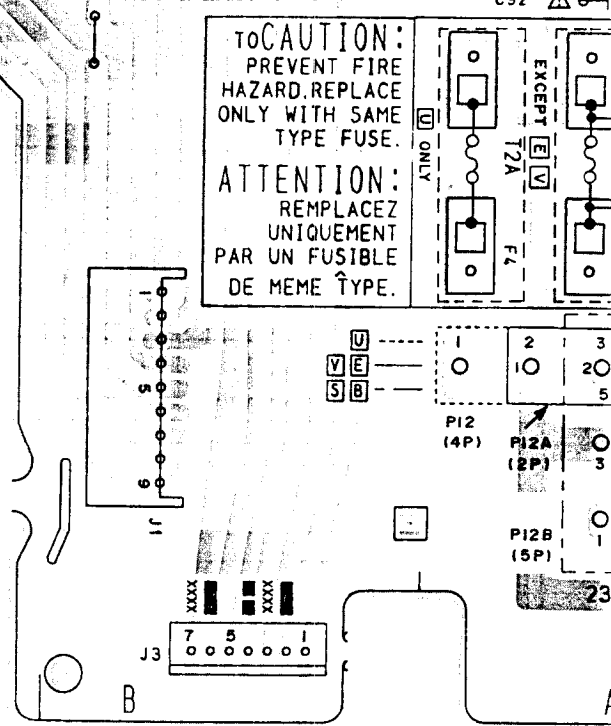

**CONTROL PCB A5013A501C**

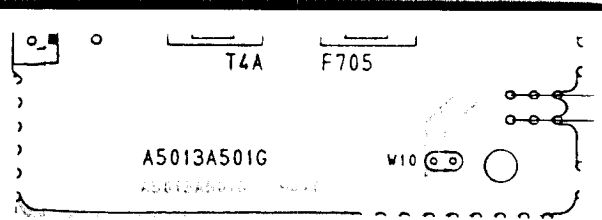
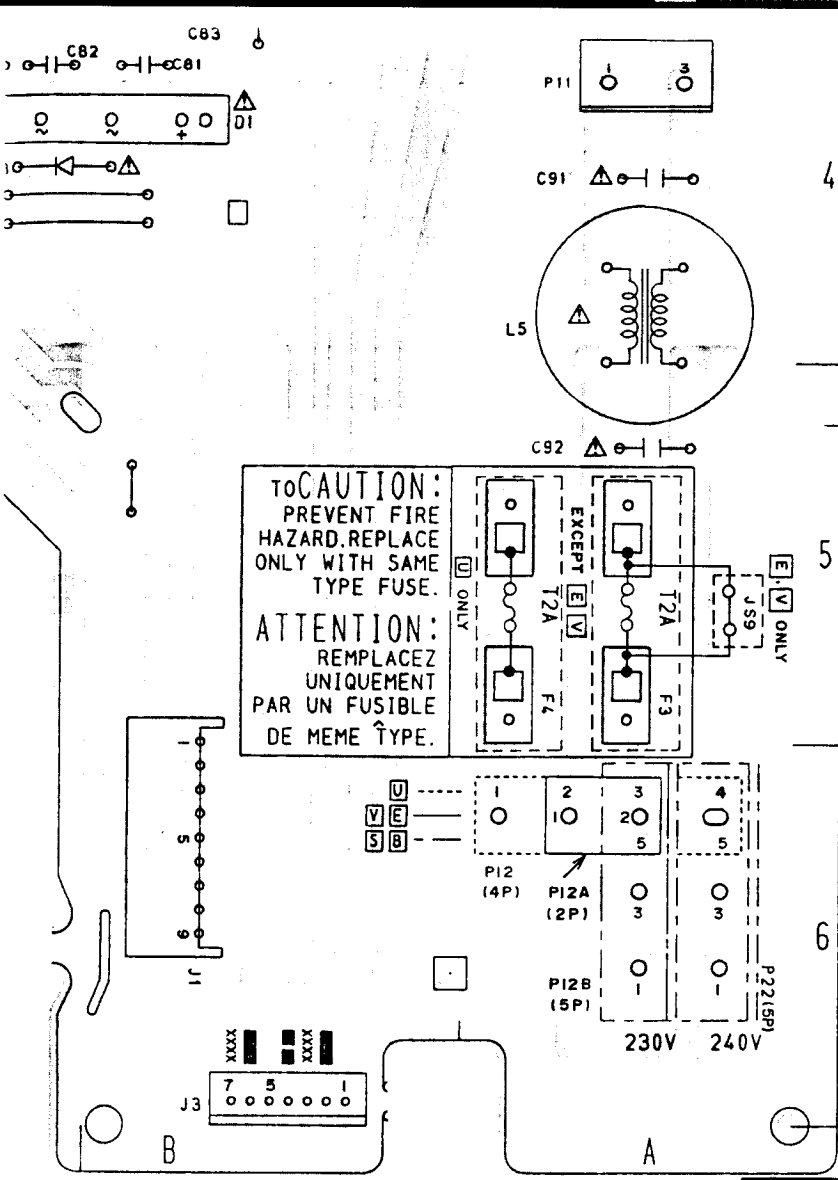

FUSE PCB A5013A501G

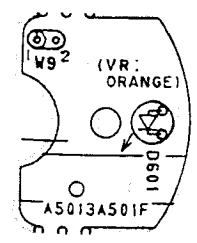

INDICATOR PCB A5013A501F

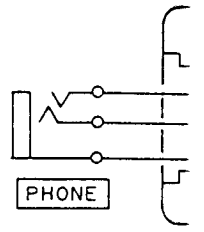

PHONE PCB

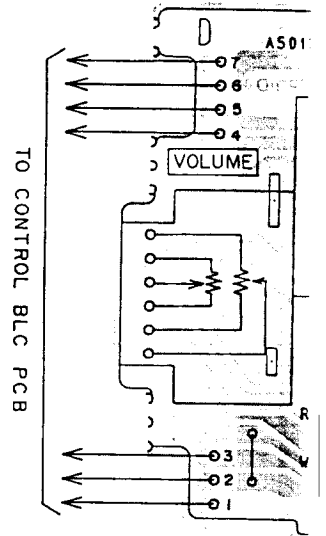

MAIN VR PCB

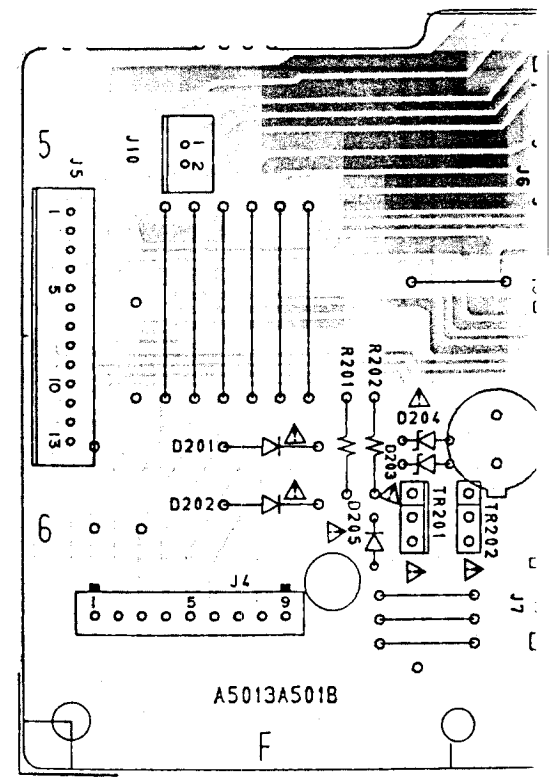
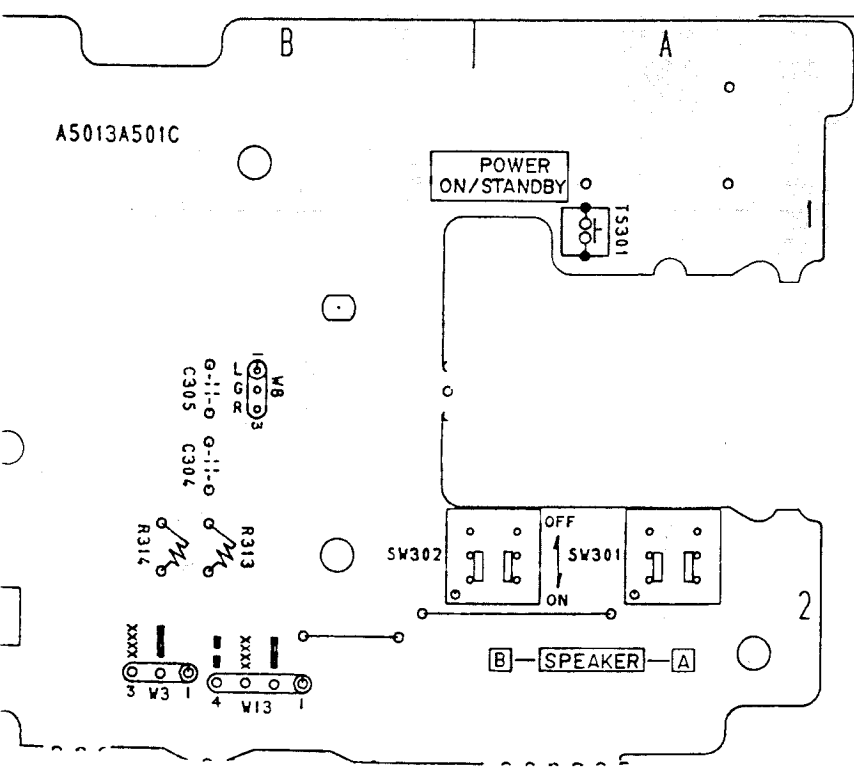

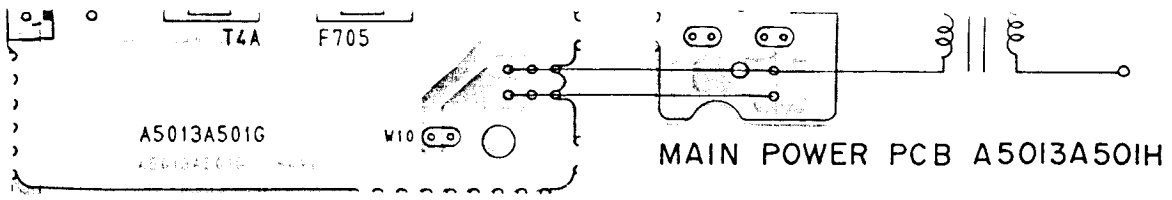

FUSE PCB A5013A501G

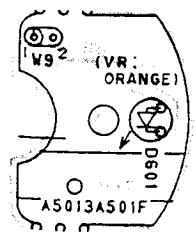

INDICATOR PCB A5013A501F

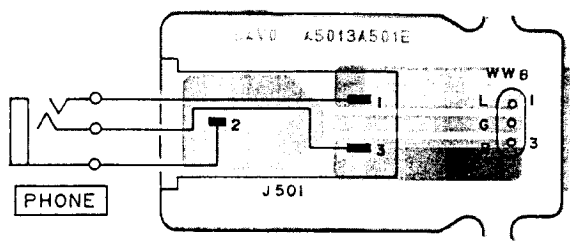

PHONE JACK PCB A5013A501E

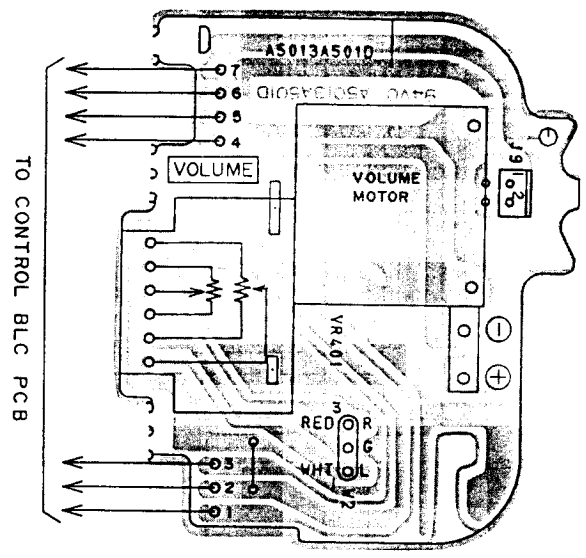

MAIN VR PCB A5013A501D

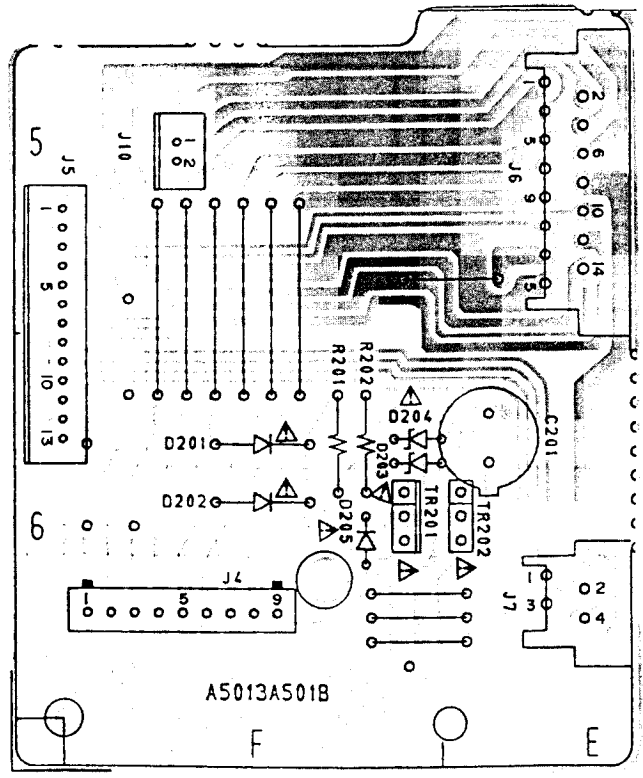

E-V ONLY  
JS9

P2218P1  
AC

1

TAPE I  
PB HEAD  
H901  
MK10P-AB2H3

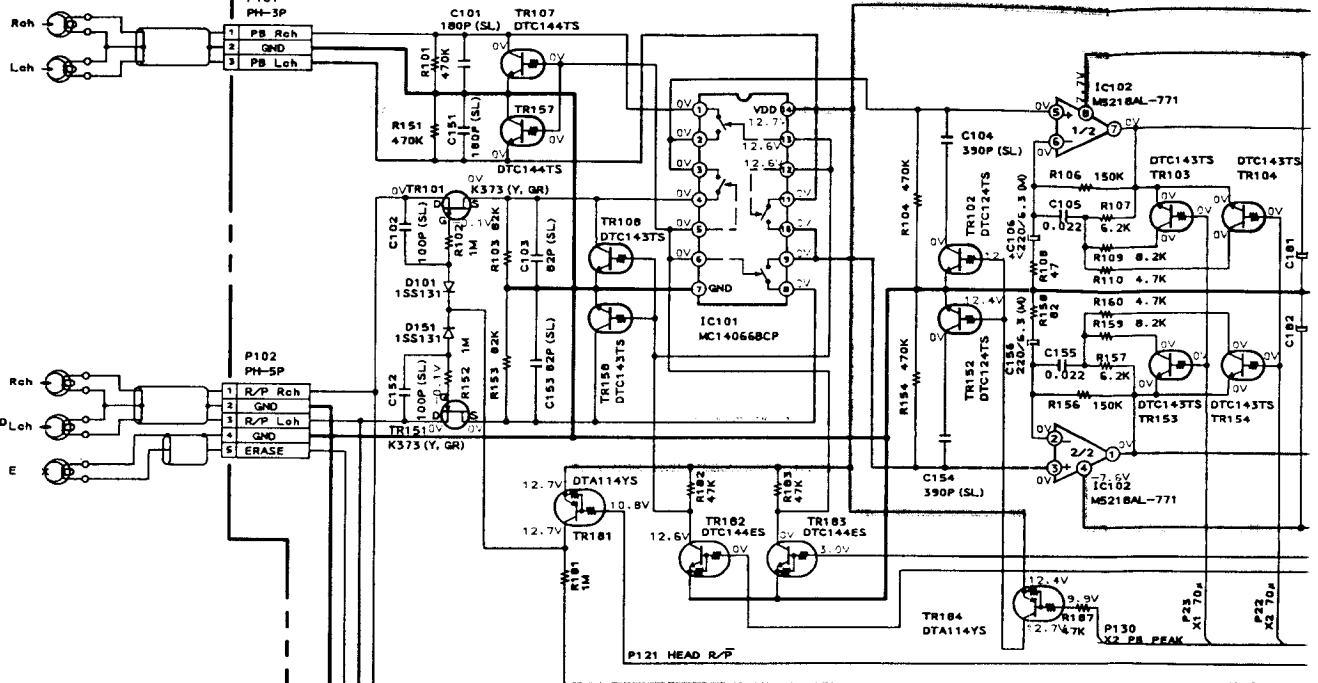

2

TAPE II  
REC/PB/E HEAD  
H901  
YK56R-AA4H3

3

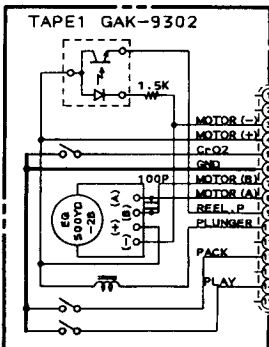

4

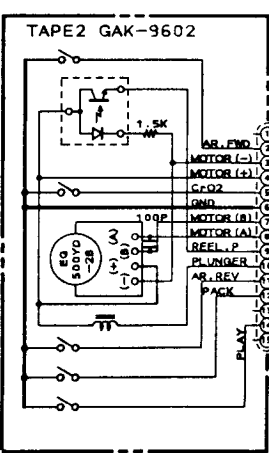

5

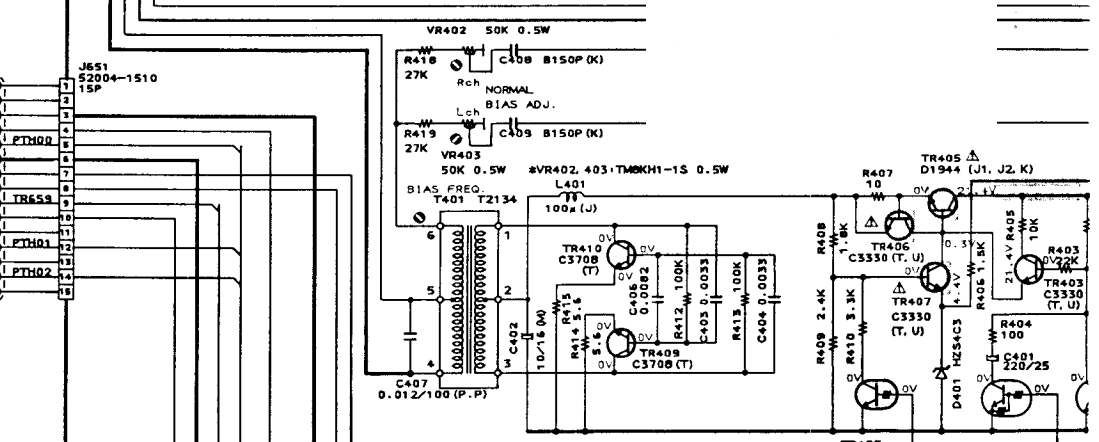

\* PLEASE NOTE THAT THERE ARE TWO TYPES OF CIRCUITS FOR THE CIRCUIT ENCLOSED IN THE DOTTED LINES.

6

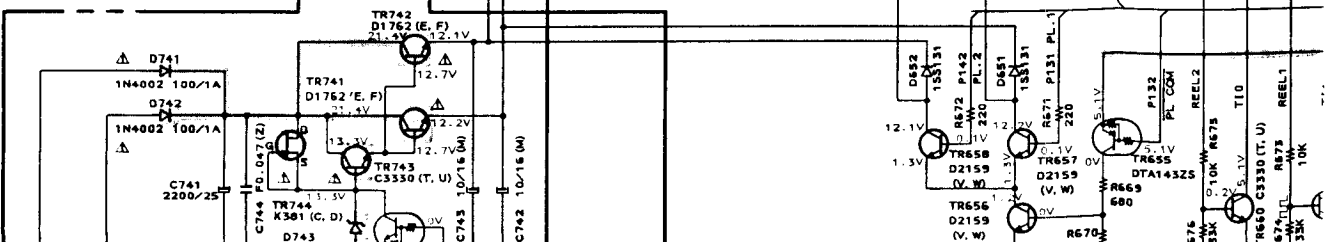

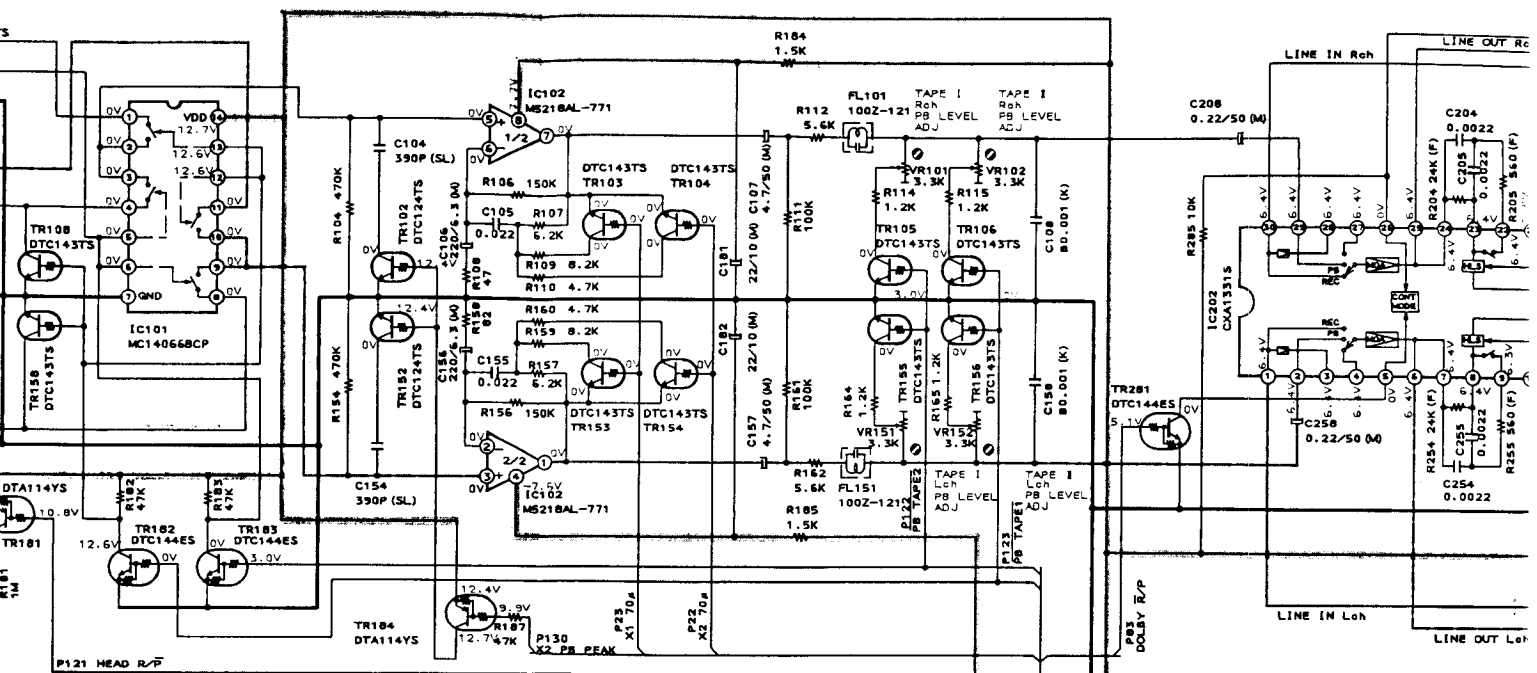

RTV servis Horvat

Kešinci, 31402 Semeljci

031-856-139

031-856-637

098-788-319

rtv.servis.horvat@os.tel.hr

Croatia

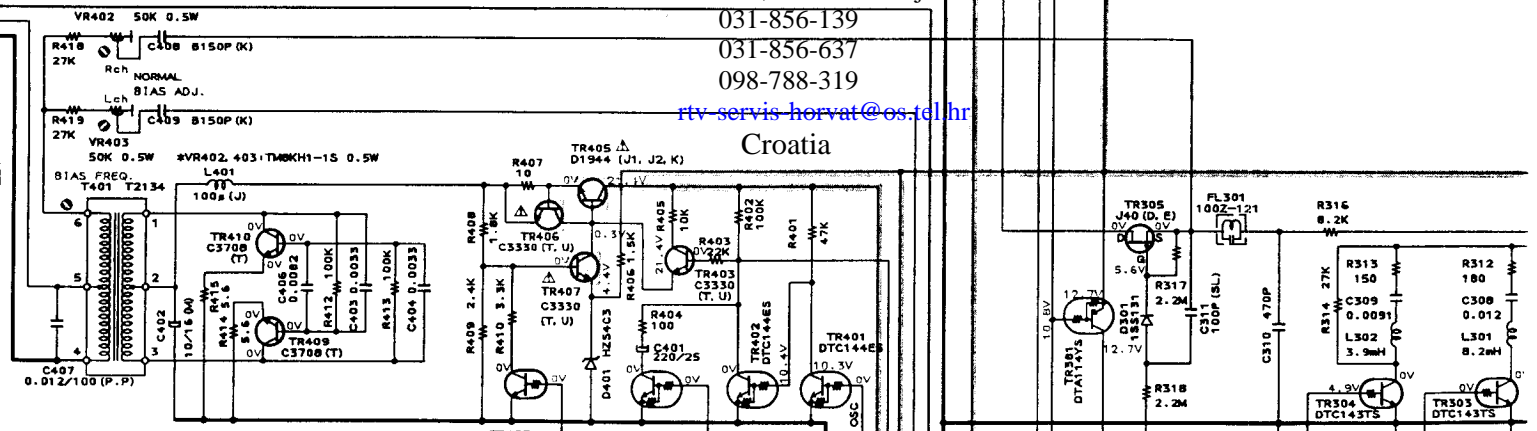

\* PLEASE NOTE THAT THERE ARE TWO TYPES OF CIRCUITS FOR THE CIRCUIT ENCLOSED IN THE DOTTED LINES.

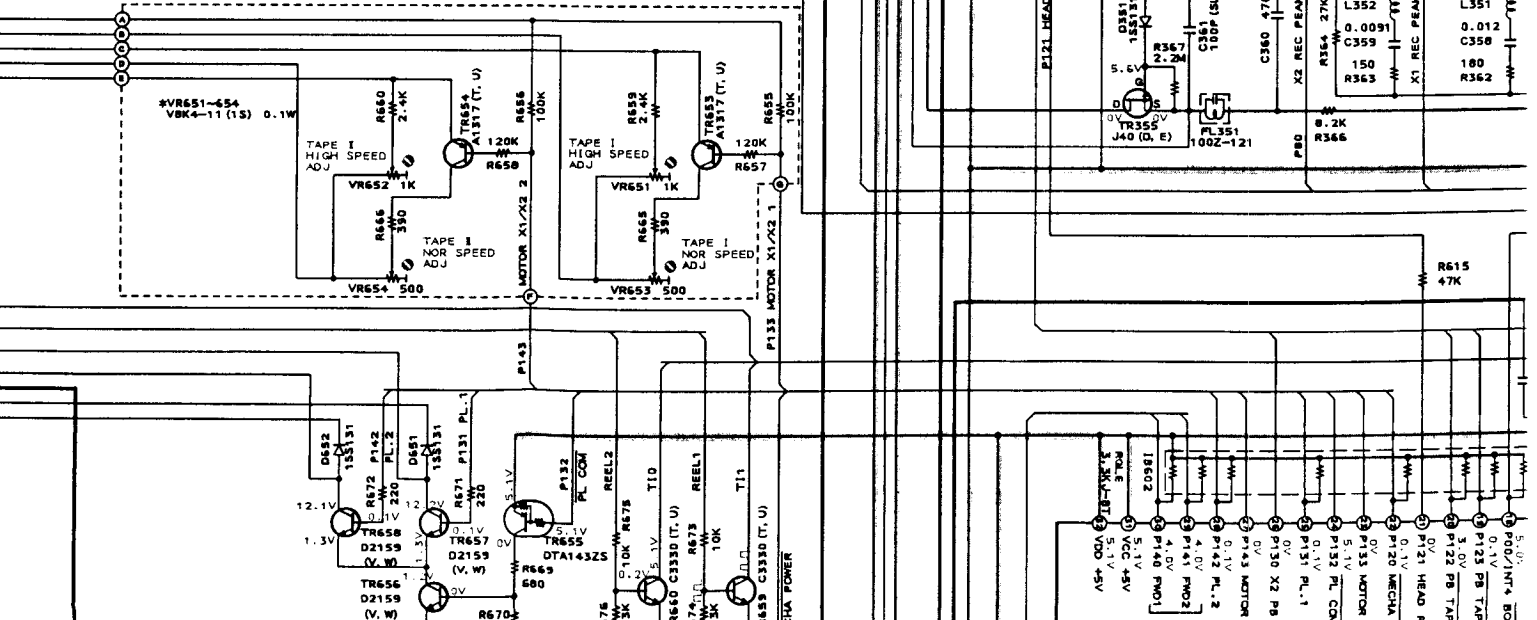

F

G

H

I

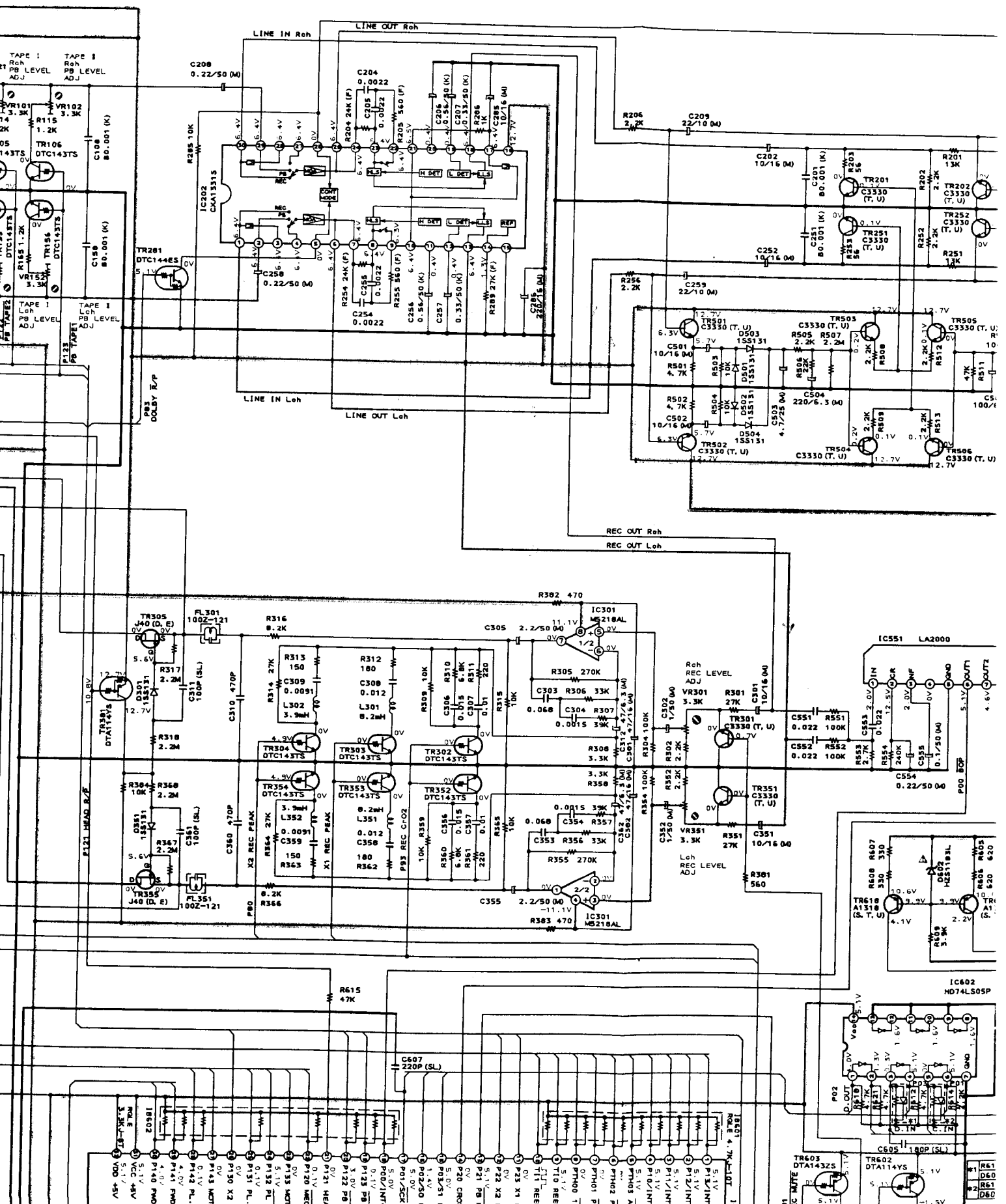



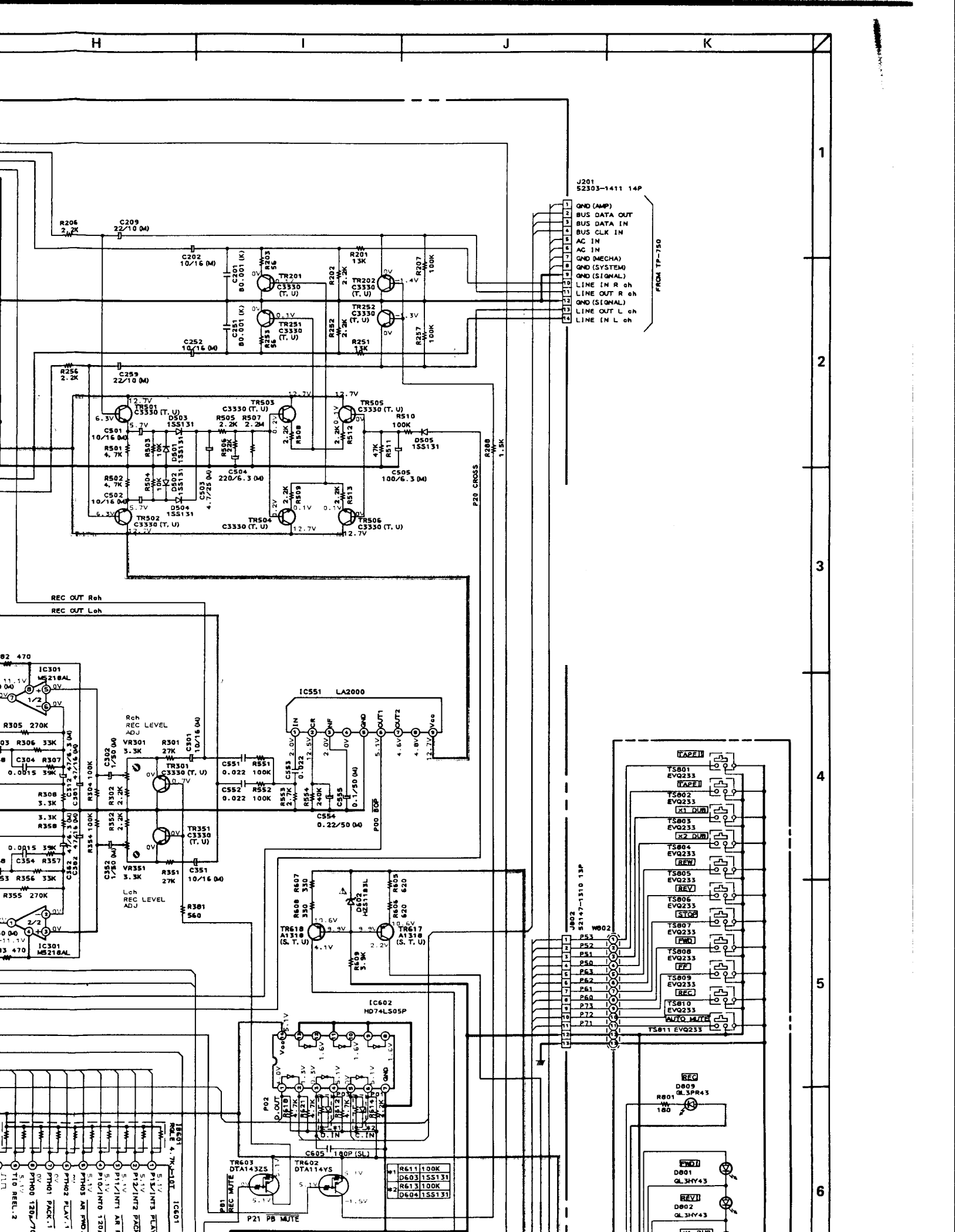

1  
2  
3  
4  
5  
6

- J201  
52303-1411 14P
- 1 GND (AMP)
  - 2 BUS DATA OUT
  - 3 BUS DATA IN
  - 4 BUS CLK IN
  - 5 AC IN
  - 6 AC IN
  - 7 GND (MECHA)
  - 8 GND (SYSTEM)
  - 9 GND (SIGNAL)
  - 10 LINE IN R oh
  - 11 LINE OUT R oh
  - 12 GND (SIGNAL)
  - 13 LINE OUT L oh
  - 14 LINE IN L oh

FROM TP-750

P20 CROSS  
R388  
1.5K

J202  
52147-1310 13P

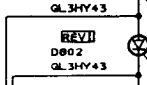
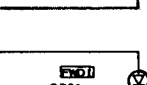
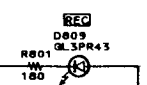
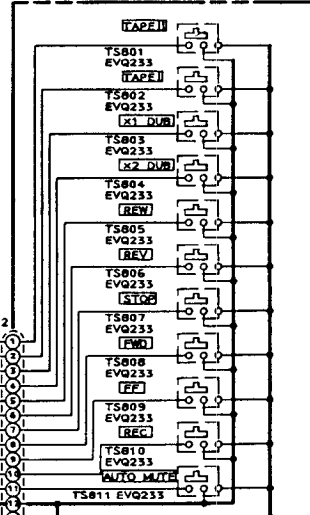

3  
4  
5  
6  
7  
8

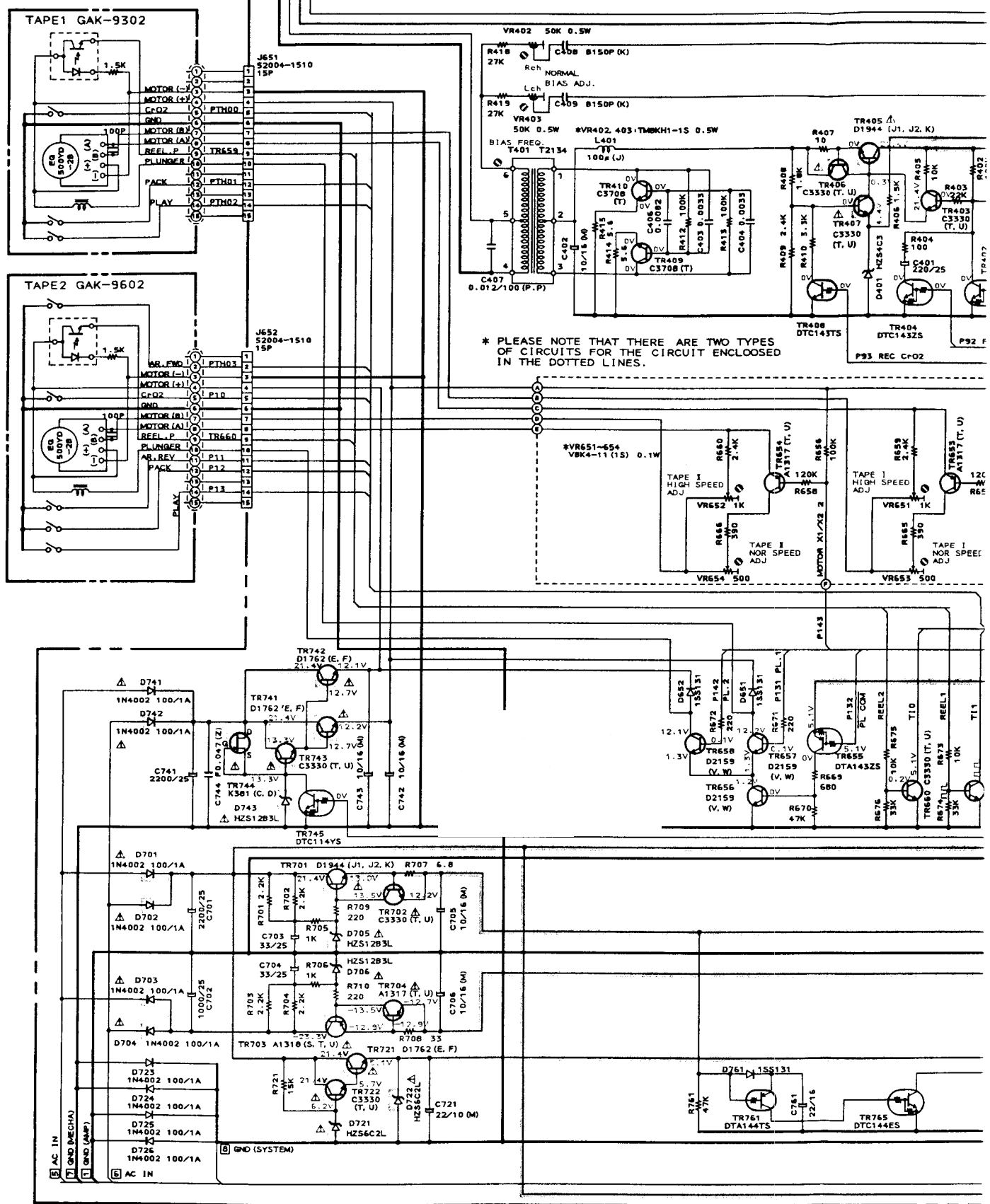

DECK PCB T2134A501A

INDICATED VOLTAGES WERE MEASURED DURING PB MODE  
(CONDITION: TAPE I, FWD PLAY, NORMAL TAPE, DOLBY OFF)

IB (POWER SUP)  
PB SIGNAL L  
REC SIGNAL I

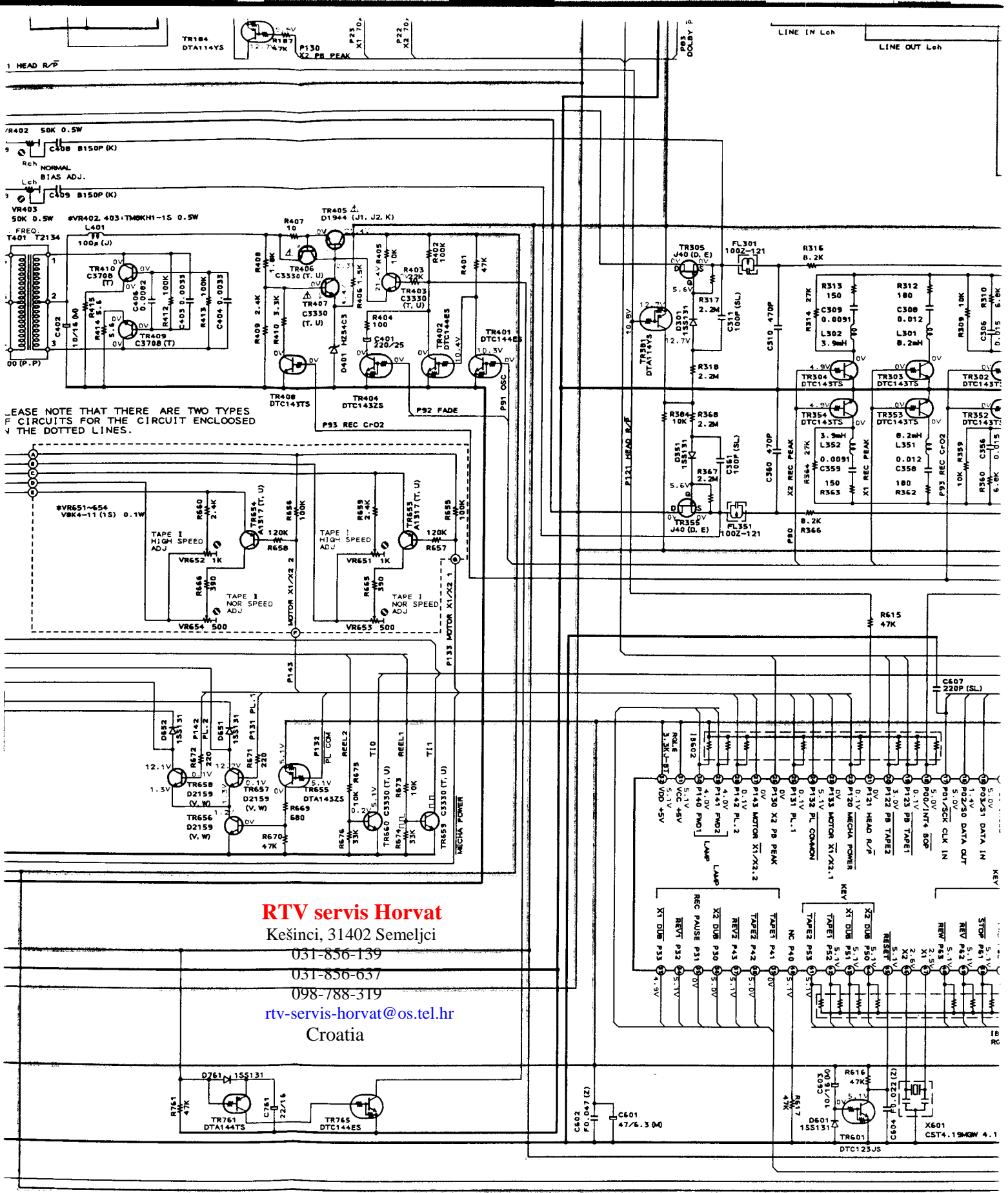

**RTV servis Horvat**

Kešinci, 31402 Semeljci

031-856-139

031-856-637

098-788-319

[rtv-servis-horvat@os.tel.hr](mailto:rtv-servis-horvat@os.tel.hr)

Croatia

MEASURED DURING PB MODE  
AV. NORMAL TAPE, DOLBY OFF

- IB (POWER SUPPLY) LINE
- PB SIGNAL LINE
- REC SIGNAL LINE

WARNING: AND COMPONENT REPLACE S. ONLY WITH PARTS  
AVERTISSEMENT: ET COMPOSANT POUR MAIN DE L'APPA PIÈCES RE

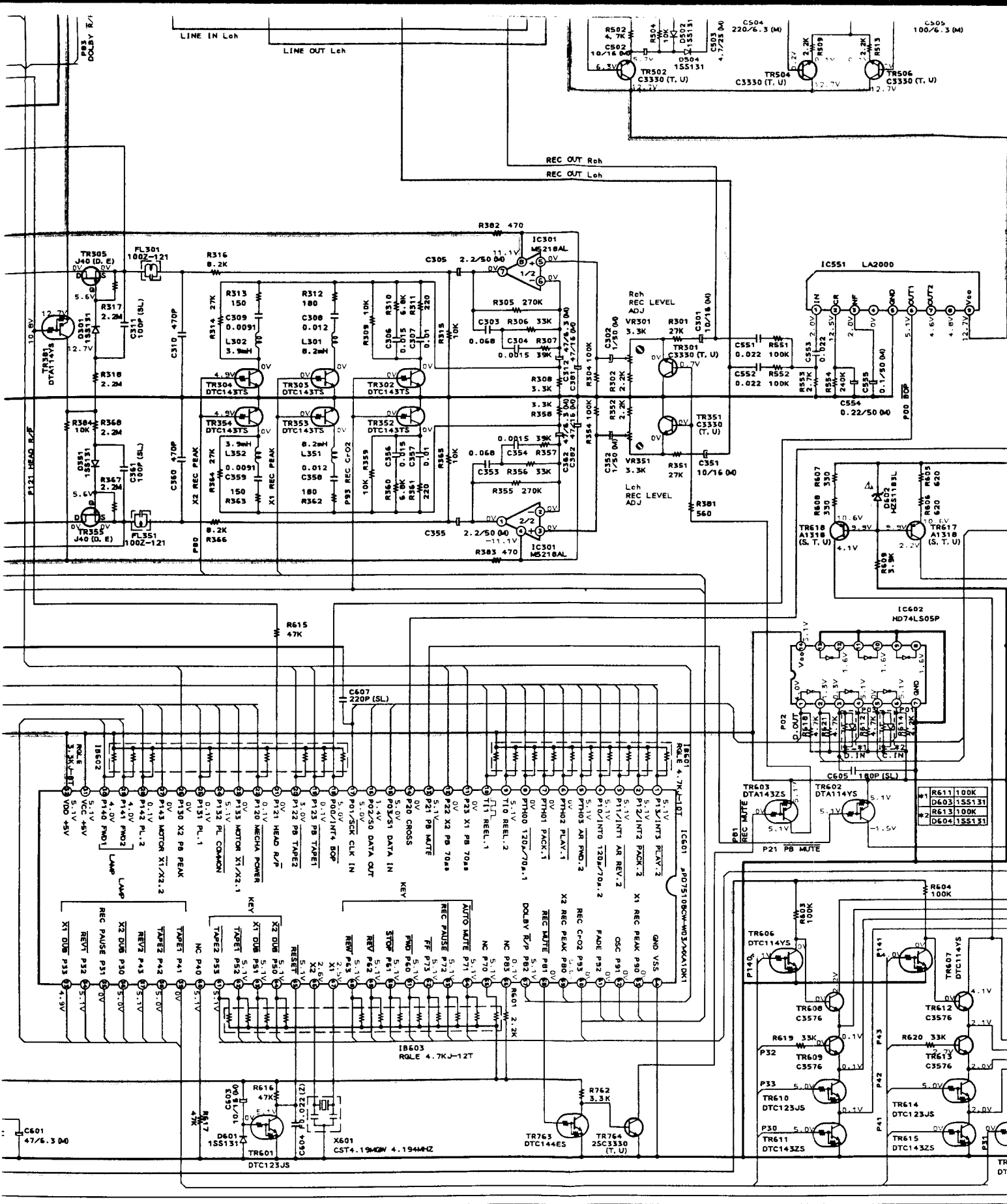

WARNING:  $\Delta$  AND  $\square$  INDICATE SAFETY CRITICAL COMPONENTS FOR CONTINUED SAFETY. REPLACE SAFETY CRITICAL COMPONENTS ONLY WITH MANUFACTURER'S RECOMMENDED PARTS.

AVERTISSEMENT:  $\Delta$  ET  $\square$  ILS INDICENT LES COMPOSANTS CRITIQUES DE SÉCURITÉ. POUR MAINTENIR LE DEGRÉ DE SÉCURITÉ DE L'APPAREIL NE REMPLACER QUE DES PIÈCES RECOMMANDÉES PAR LE FABRICANT

NOTE: UNLESS OTHERWISE SPECIFIED ALL RESISTORS IN OHMS ALL CAPACITORS IN  $\mu$ F

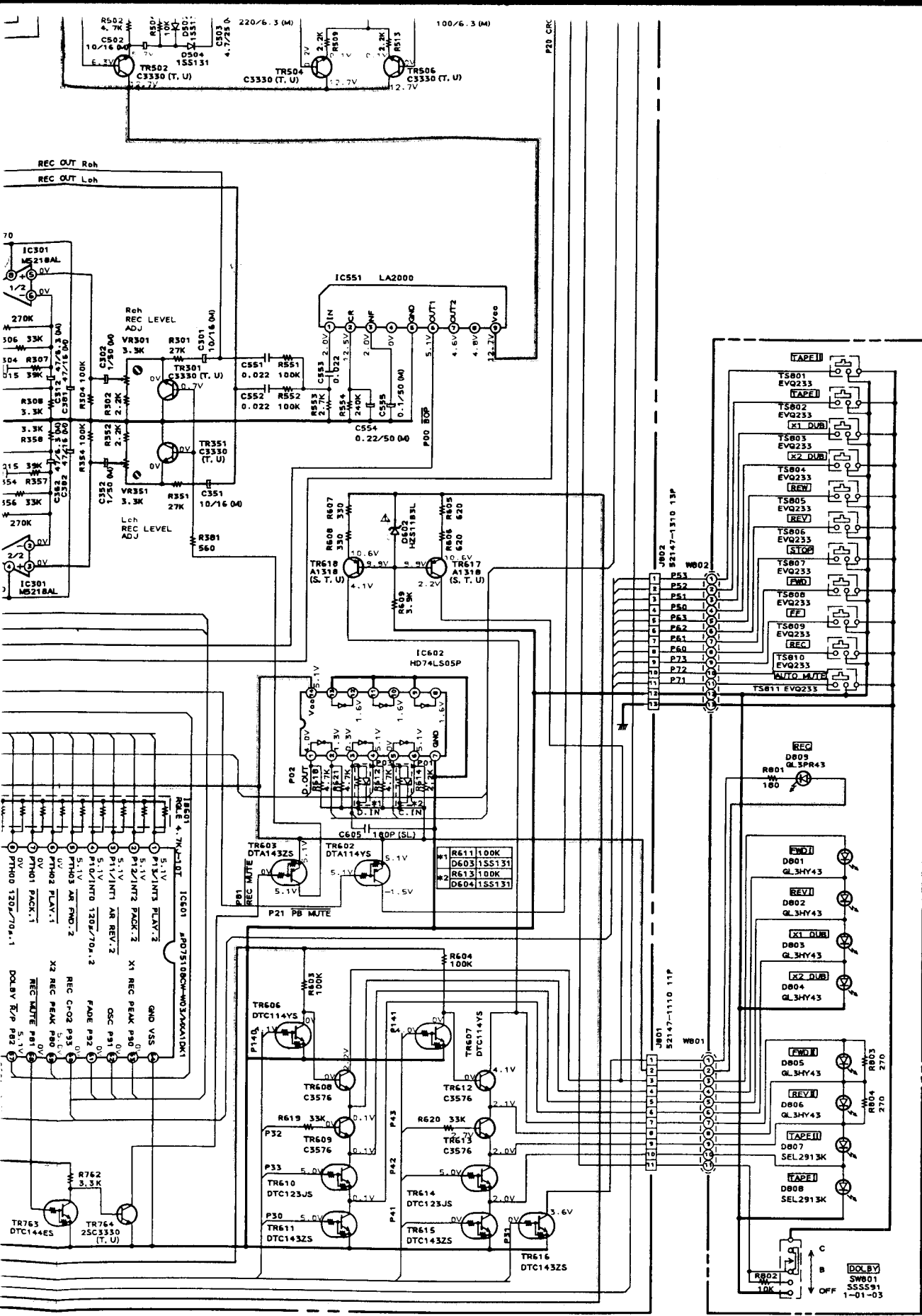

OPERATION PCB T2134A501B

NOTE  
UNLESS OTHERWISE SPECIFIED  
ALL RESISTORS IN OHMS  
ALL CAPACITORS IN pF

TICAL  
Y.  
ENTS  
AMENDED  
LES  
URITÉ  
DES  
TRICANT

3  
4  
5  
6  
7  
8

\* ANOTHER TYPE

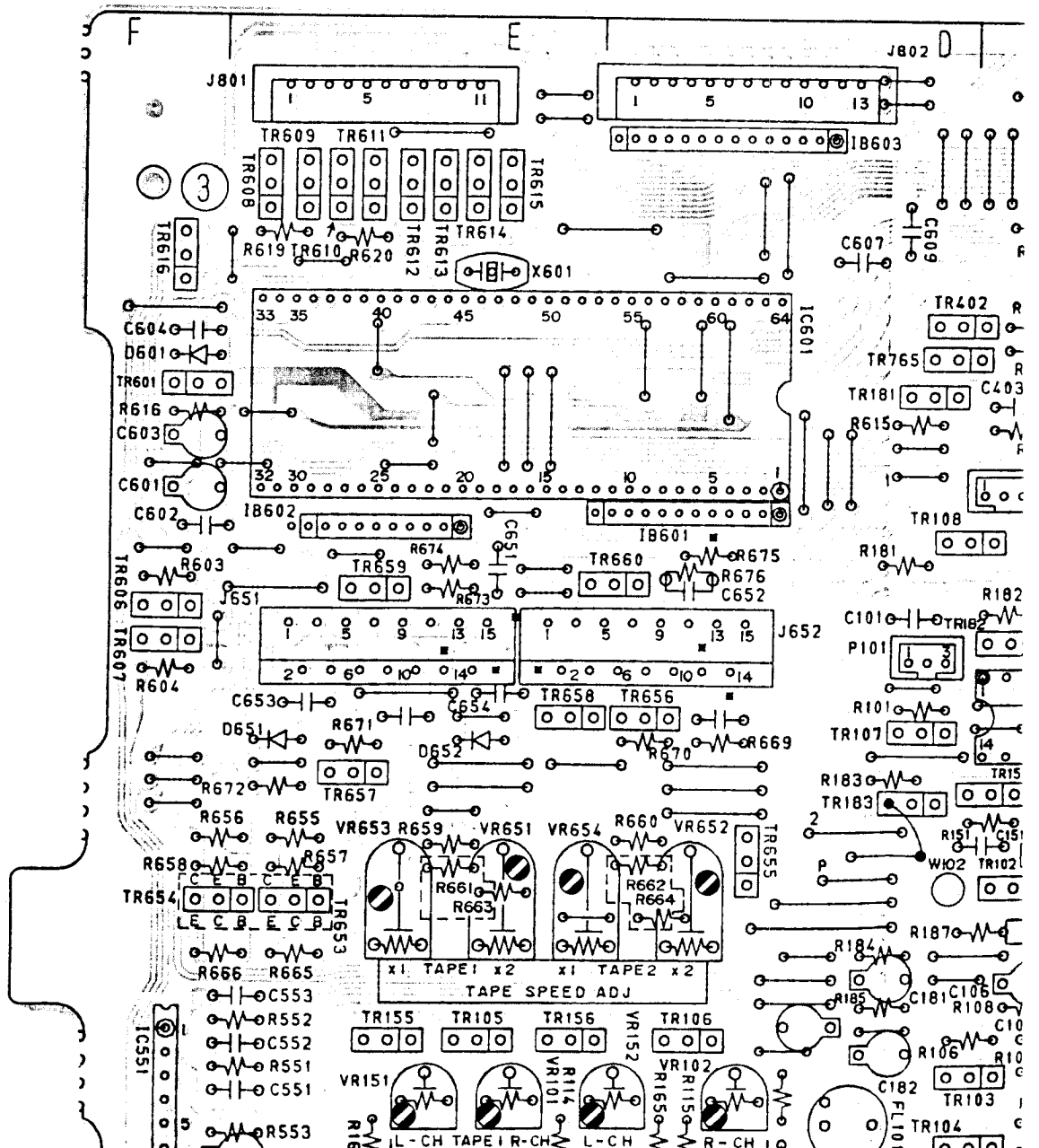
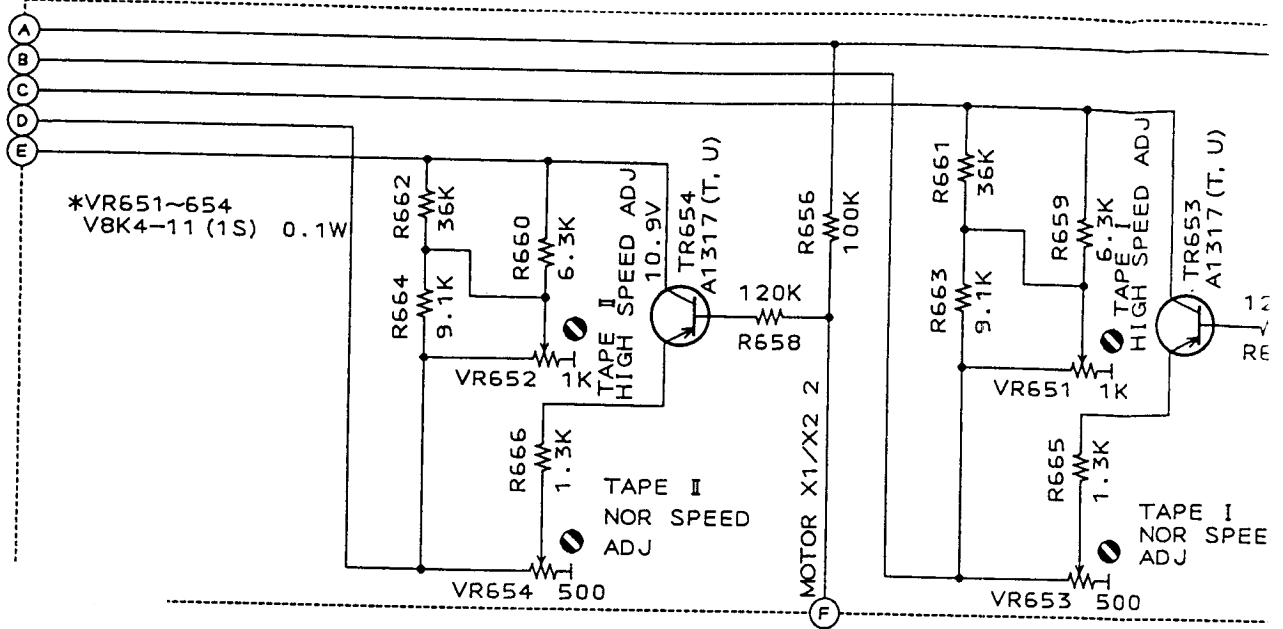

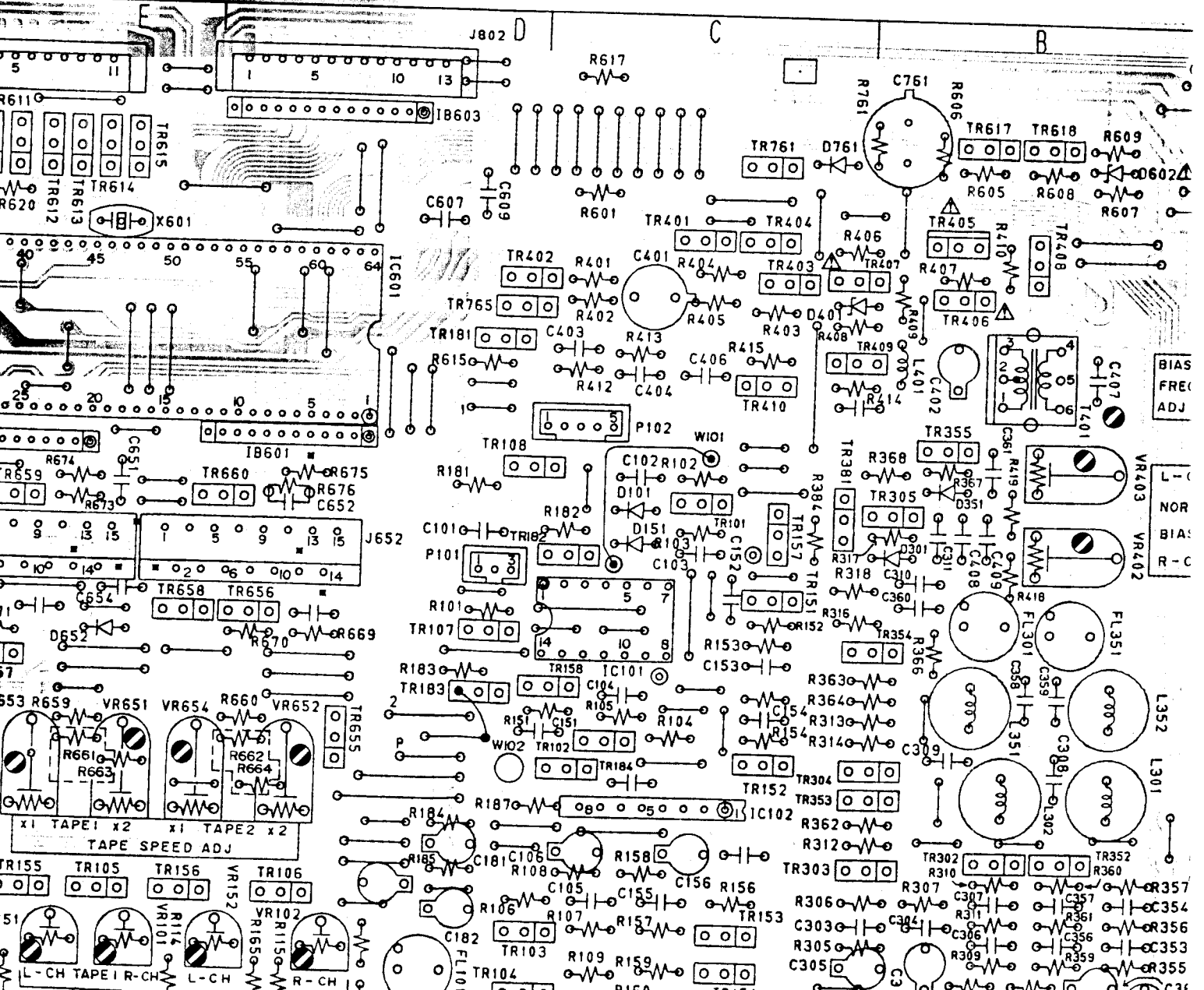
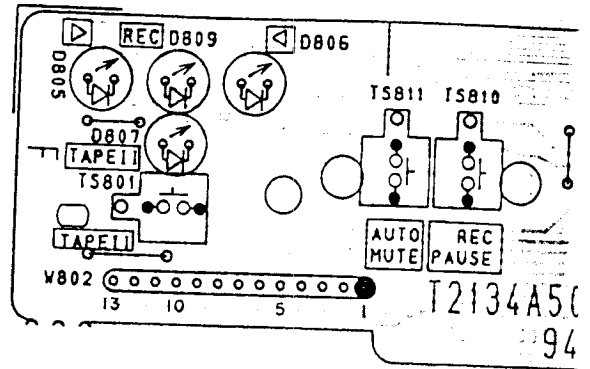
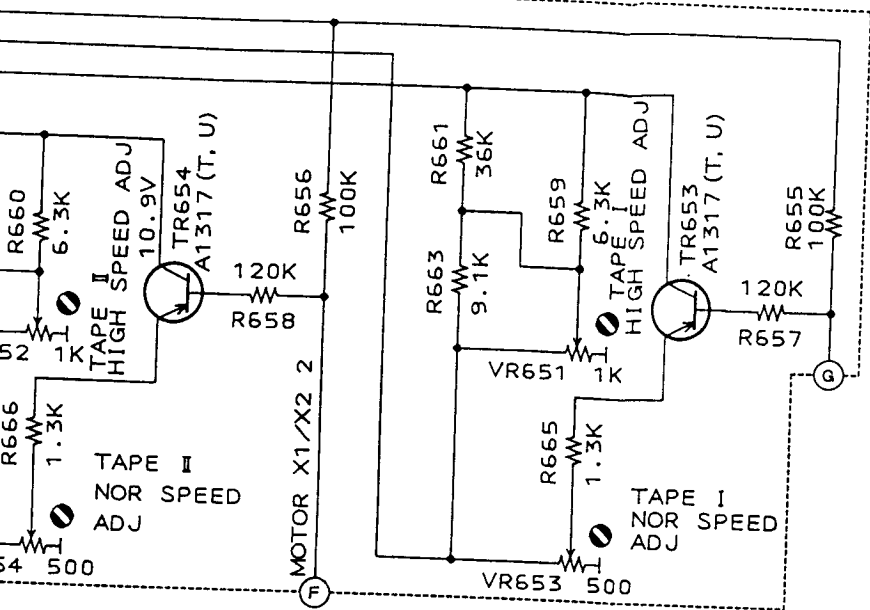

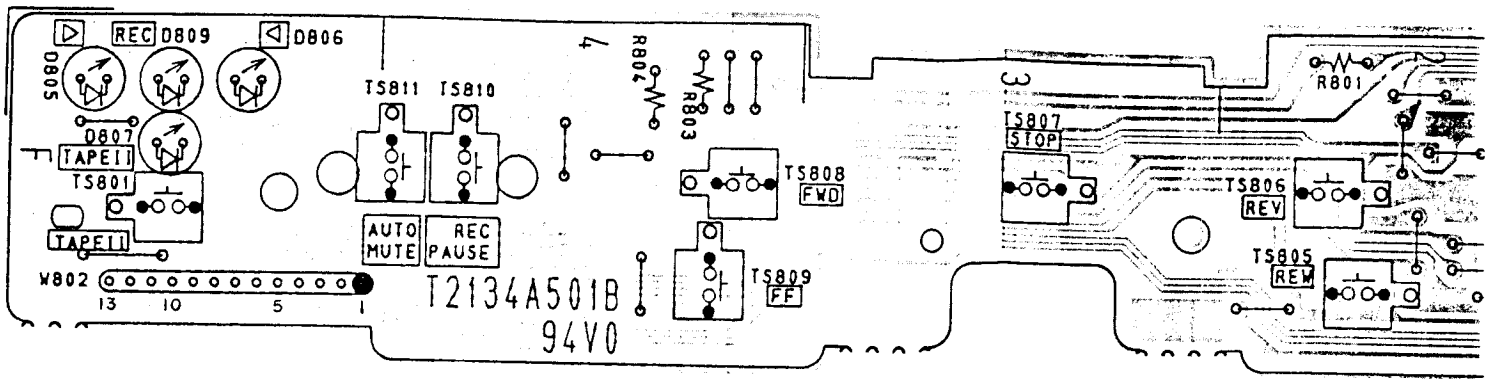

OPERATION PCB T2134A501B

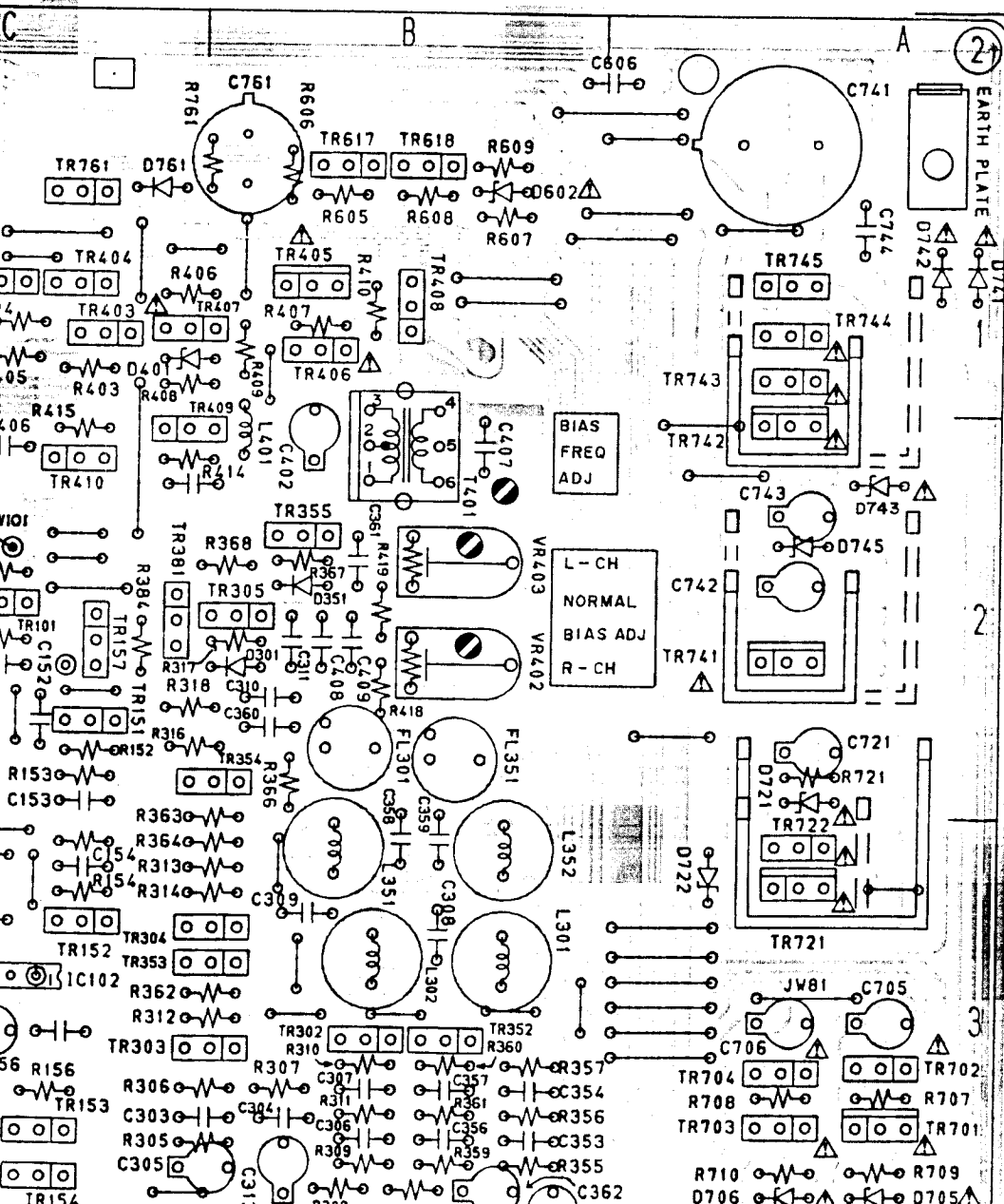

PRINCIPAL PARTS LOCATION

ICs		
IC101	..... C2	TI
IC102	..... C3	TI
IC202	..... D,E4	TI
IC301	..... B4	TF
IC551	..... F3,4	TF
IC601	..... D,E1	TF
IC602	..... B4	TF

CONNECTORS

P101	..... D2	TF
P102	..... C2	TF
J201	..... B5	TF
J651	..... E2	TF
J652	..... D,E2	TF
J801	..... E1	TF
J802	..... D1	TF

TRANSISTORS

TR101	..... C2	TF
TR102	..... C3	TF
TR103	..... C,D3	TF
TR104	..... C,D3	TF
TR105	..... E3	TF
TR106	..... D3	TF
TR107	..... D2	TF
TR108	..... C,D2	TR
TR151	..... C2	TR
TR152	..... C3	TR
TR153	..... C3	TR
TR154	..... C3	TR
TR155	..... E3	TR
TR156	..... D,E3	TR
TR157	..... C2	TR
TR158	..... C3	TR
TR181	..... D1	TR
TR182	..... C2	TR
TR183	..... D2	TR



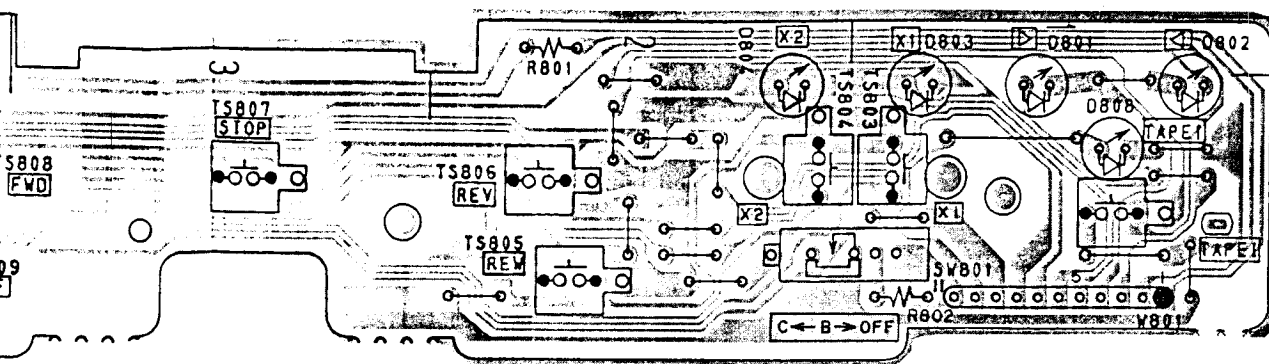

OPERATION PCB T2134A501B

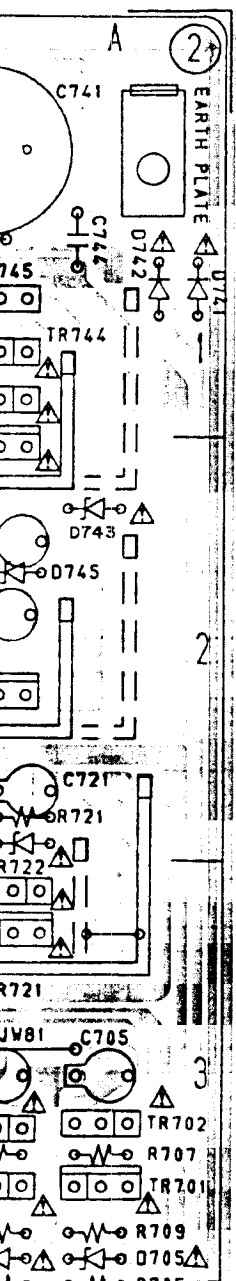

**PRINCIPAL PARTS LOCATION**

**ICs**

IC101 .....	C2	TR402 .....	C, D1
IC102 .....	C3	TR403 .....	C1
IC202 .....	D, E4	TR404 .....	C1
IC301 .....	B4	TR405 .....	B1
IC551 .....	F3,4	TR406 .....	B1
IC601 .....	D, E1	TR407 .....	B, C1
IC602 .....	B4	TR408 .....	B1

**CONNECTORS**

P101 .....	D2	TR409 .....	B, C2
P102 .....	C2	TR410 .....	C2
J201 .....	B5	TR501 .....	B, C5
J651 .....	E2	TR502 .....	B, C5
J652 .....	D, E2	TR503 .....	C5
J801 .....	E1	TR504 .....	C5
J802 .....	D1	TR505 .....	C4
		TR506 .....	C4

**TRANSISTORS**

TR101 .....	C2	TR601 .....	F1
TR102 .....	C3	TR602 .....	B4
TR103 .....	C, D3	TR603 .....	B4
TR104 .....	C, D3	TR606 .....	F2
TR105 .....	E3	TR607 .....	F2
TR106 .....	D3	TR608 .....	E1
TR107 .....	D2	TR609 .....	E1
TR108 .....	C, D2	TR610 .....	E1
TR151 .....	C2	TR611 .....	E1
TR152 .....	C3	TR612 .....	E1
TR153 .....	C3	TR613 .....	E1
TR154 .....	C3	TR614 .....	E1
TR155 .....	E3	TR615 .....	E1
TR156 .....	D, E3	TR616 .....	F1
TR157 .....	C2	TR617 .....	B1
TR158 .....	C3	TR618 .....	B1
TR181 .....	D1	TR653 .....	E3
TR182 .....	C2	TR654 .....	E, F3
TR183 .....	D3	TR655 .....	D3
		TR656 .....	D2
		TR657 .....	E2,3
		TR658 .....	E2

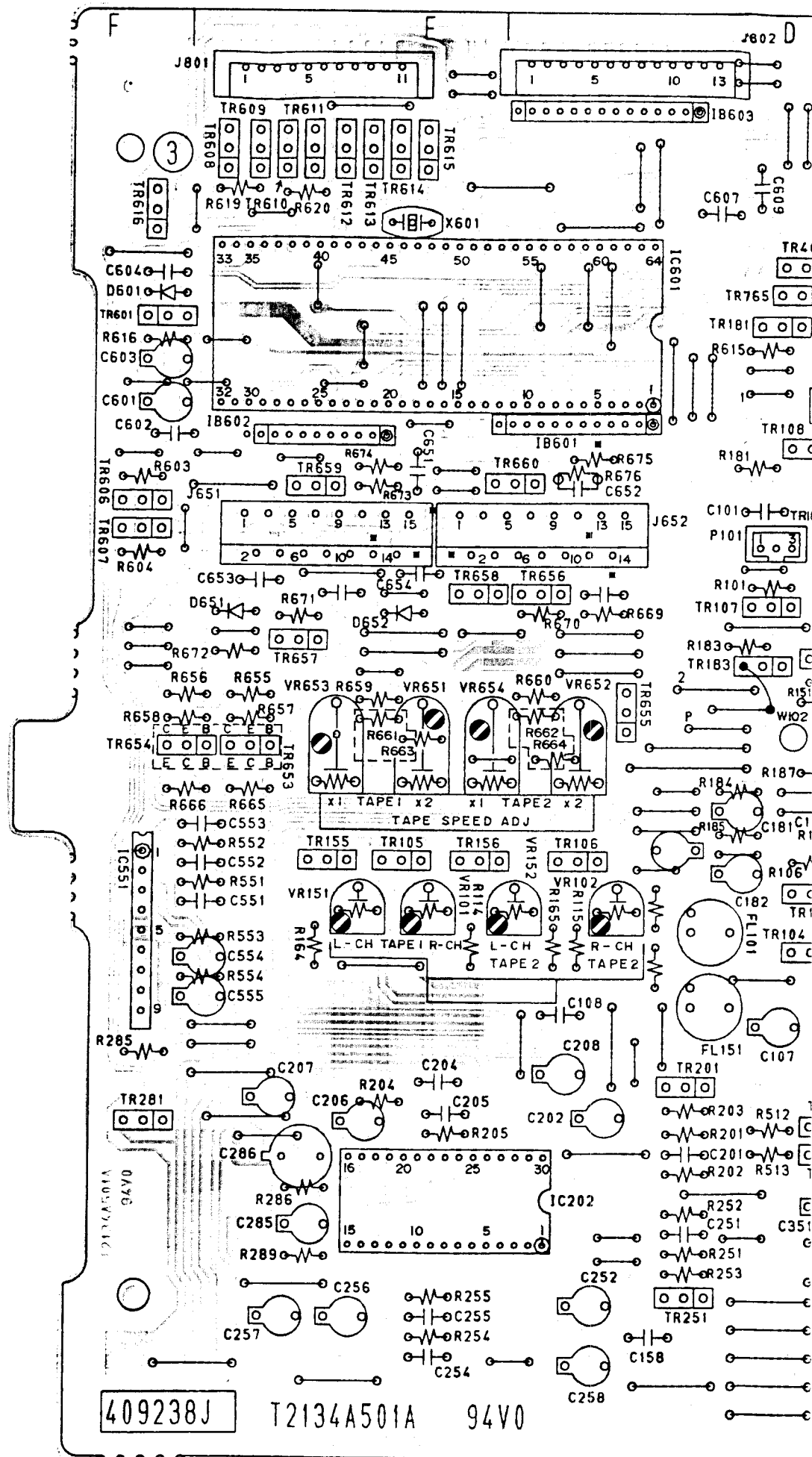

409238J

T2134A501A

94V0

WARNING:  $\Delta$  INDICATES SAFETY CRITICAL COMPONENTS. FOR CONTINUED SAFETY, REPLACE SAFETY CRITICAL COMPONENTS ONLY WITH MANUFACTURER'S RECOMMENDED PARTS.

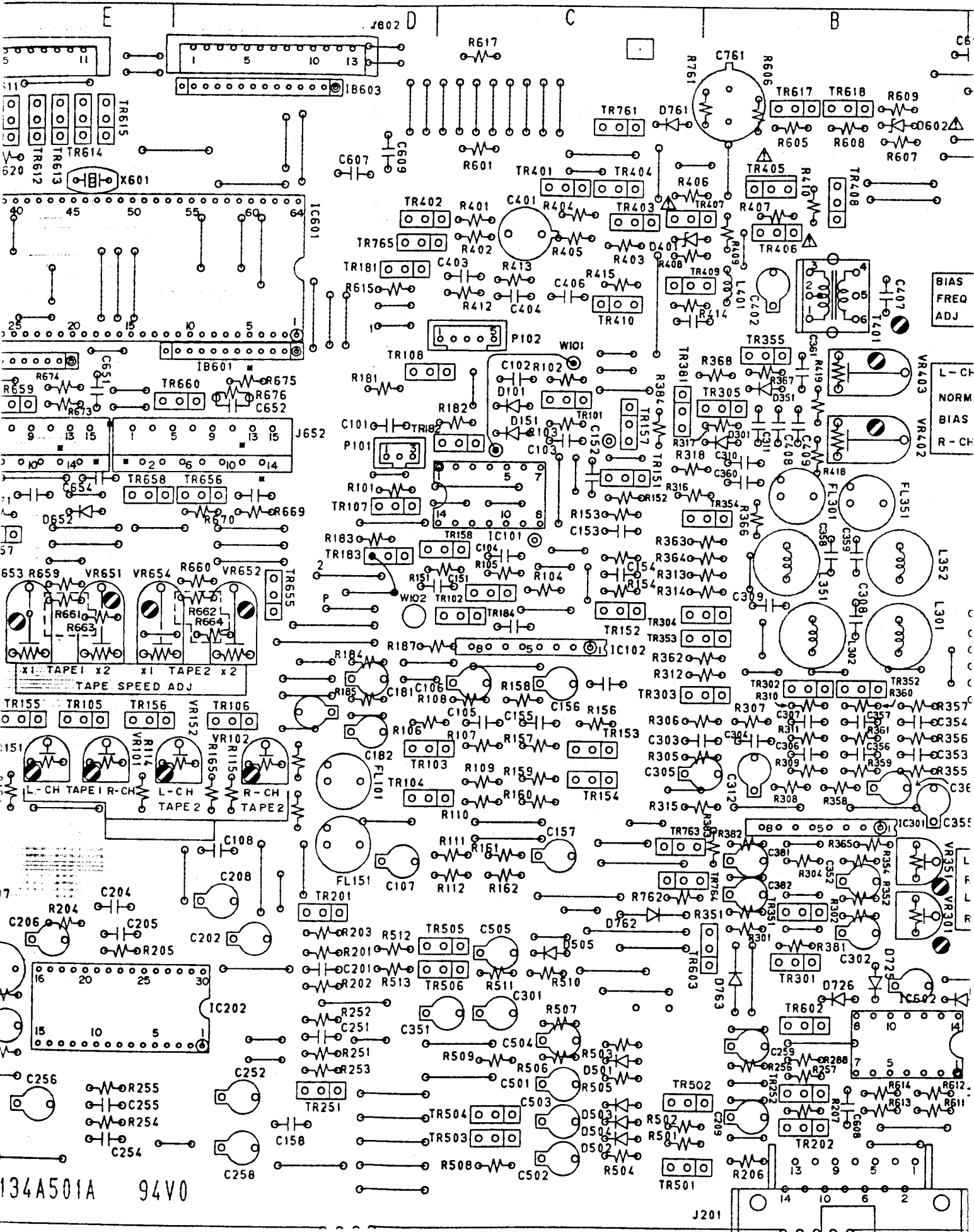

134A501A 94V0

DECK PCB T2134A501A

REPLACES SAFETY CRITICAL COMPONENTS. FOR CONTINUED SAFETY, USE SAFETY CRITICAL COMPONENTS ONLY WITH MANUFACTURER'S RECOMMENDED PARTS.

For Service Manuals Contact

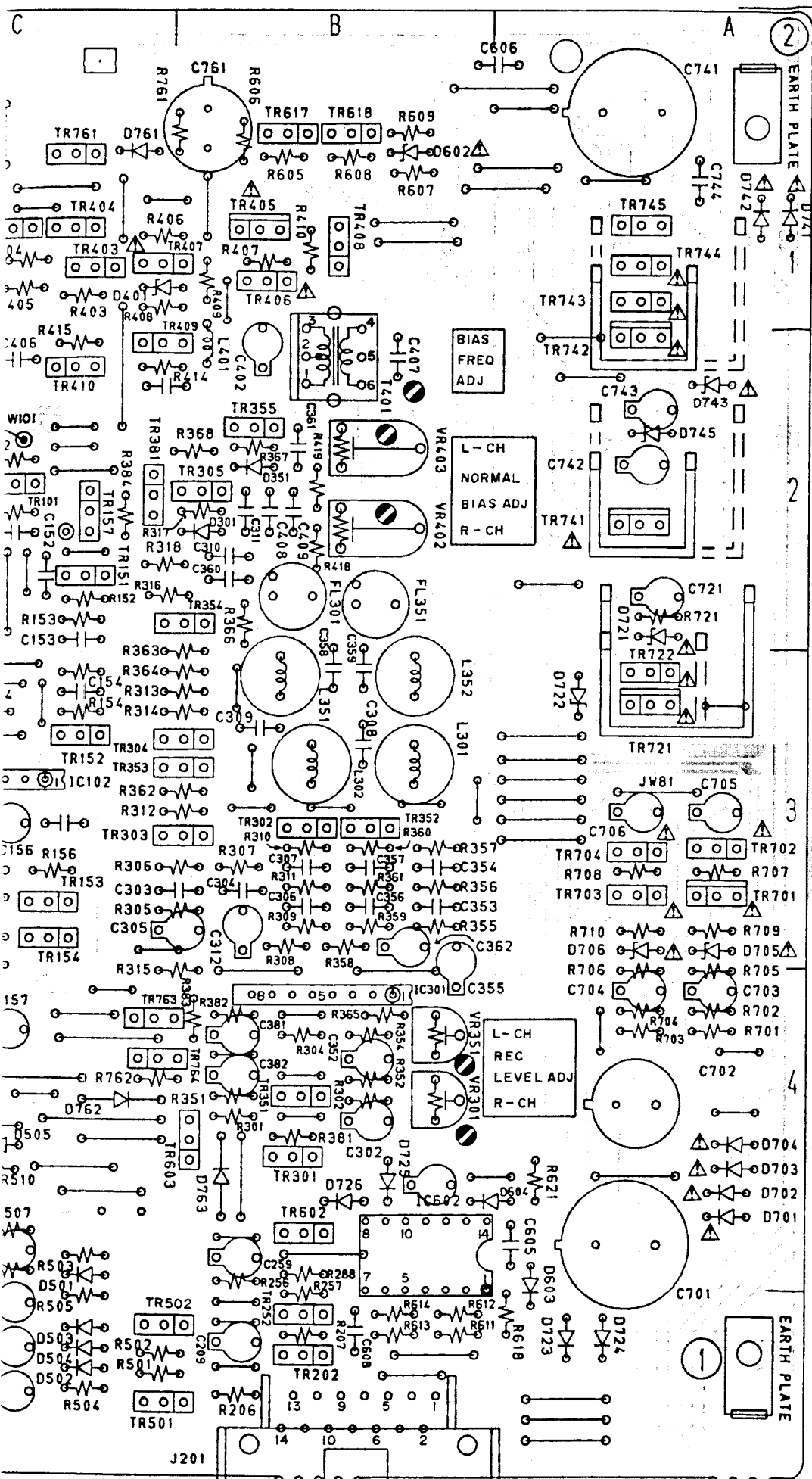

**PRINCIPAL PARTS LOCATION**

**ICs**

IC101 .....	C2	TF
IC102 .....	C3	TF
IC202 .....	D,E4	TF
IC301 .....	B4	TF
IC551 .....	F3,4	TF
IC601 .....	D,E1	TF
IC602 .....	B4	TF

**CONNECTORS**

P101 .....	D2	TF
P102 .....	C2	TF
J201 .....	B5	TF
J651 .....	E2	TF
J652 .....	D,E2	TF
J801 .....	E1	TF
J802 .....	D1	TF

**TRANSISTORS**

TR101 .....	C2	TF
TR102 .....	C3	TF
TR103 .....	C,D3	TF
TR104 .....	C,D3	TF
TR105 .....	E3	TF
TR106 .....	D3	TF
TR107 .....	D2	TF
TR108 .....	C,D2	TF
TR151 .....	C2	TF
TR152 .....	C3	TF
TR153 .....	C3	TF
TR154 .....	C3	TF
TR155 .....	E3	TF
TR156 .....	D,E3	TF
TR157 .....	C2	TF
TR158 .....	C3	TF
TR181 .....	D1	TF
TR182 .....	C2	TF
TR183 .....	D3	TF
TR184 .....	C3	TF
TR201 .....	D4	TF
TR202 .....	B5	TF
TR251 .....	D5	TF
TR252 .....	B5	TF
TR281 .....	F4	TF
TR301 .....	B4	TF
TR302 .....	B3	TF
TR303 .....	B,C3	TF
TR304 .....	B,C3	TF
TR305 .....	B2	TF
TR351 .....	B4	TF
TR352 .....	B3	TF
TR353 .....	B,C3	TF
TR354 .....	B,C2	TF
TR355 .....	B2	TF
TR381 .....	C2	TF
TR401 .....	C1	TF

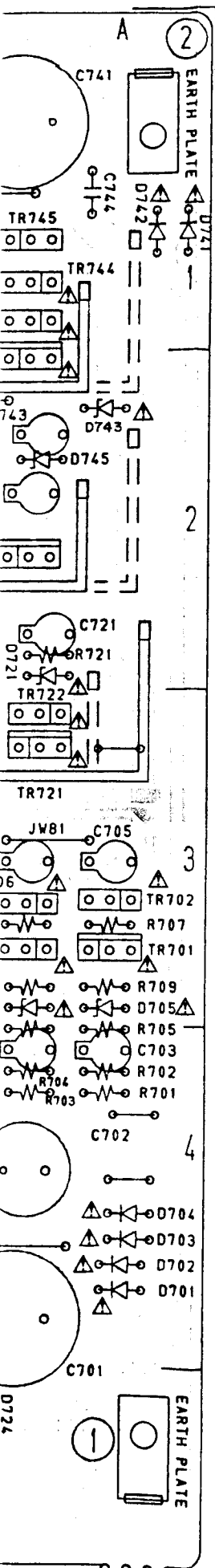

**PRINCIPAL PARTS LOCATION**

**ICs**

IC101	.....	C2
IC102	.....	C3
IC202	.....	D,E4
IC301	.....	B4
IC551	.....	F3,4
IC601	.....	D,E1
IC602	.....	B4

**CONNECTORs**

P101	.....	D2
P102	.....	C2
J201	.....	B5
J651	.....	E2
J652	.....	D,E2
J801	.....	E1
J802	.....	D1

**TRANSISTORs**

TR101	.....	C2
TR102	.....	C3
TR103	.....	C,D3
TR104	.....	C,D3
TR105	.....	E3
TR106	.....	D3
TR107	.....	D2
TR108	.....	C,D2
TR151	.....	C2
TR152	.....	C3
TR153	.....	C3
TR154	.....	C3
TR155	.....	E3
TR156	.....	D,E3
TR157	.....	C2
TR158	.....	C3
TR181	.....	D1
TR182	.....	C2
TR183	.....	D3
TR184	.....	C3
TR201	.....	D4
TR202	.....	B5
TR251	.....	D5
TR252	.....	B5
TR281	.....	F4
TR301	.....	B4
TR302	.....	B3
TR303	.....	B,C3
TR304	.....	B,C3
TR305	.....	B2
TR351	.....	B4
TR352	.....	B3
TR353	.....	B,C3
TR354	.....	B,C2
TR355	.....	B2
TR381	.....	C2
TR401	.....	C1

TR402	.....	C,D1
TR403	.....	C1
TR404	.....	C1
TR405	.....	B1
TR406	.....	B1
TR407	.....	B,C1
TR408	.....	B1
TR409	.....	B,C2
TR410	.....	C2
TR501	.....	B,C5
TR502	.....	B,C5
TR503	.....	C5
TR504	.....	C5
TR505	.....	C4
TR506	.....	C4
TR601	.....	F1
TR602	.....	B4
TR603	.....	B4
TR606	.....	F2
TR607	.....	F2
TR608	.....	E1
TR609	.....	E1
TR610	.....	E1
TR611	.....	E1
TR612	.....	E1
TR613	.....	E1
TR614	.....	E1
TR615	.....	E1
TR616	.....	F1
TR617	.....	B1
TR618	.....	B1
TR653	.....	E3
TR654	.....	E,F3
TR655	.....	D3
TR656	.....	D2
TR657	.....	E2,3
TR658	.....	E2
TR659	.....	E2
TR660	.....	D,E2
TR701	.....	A3
TR702	.....	A3
TR703	.....	A3
TR704	.....	A3
TR721	.....	A3
TR722	.....	A3
TR741	.....	A2
TR742	.....	A2
TR743	.....	A1
TR744	.....	A1
TR745	.....	A1
TR761	.....	C1
TR763	.....	B,C4
TR764	.....	B,C4
TR765	.....	C,D1

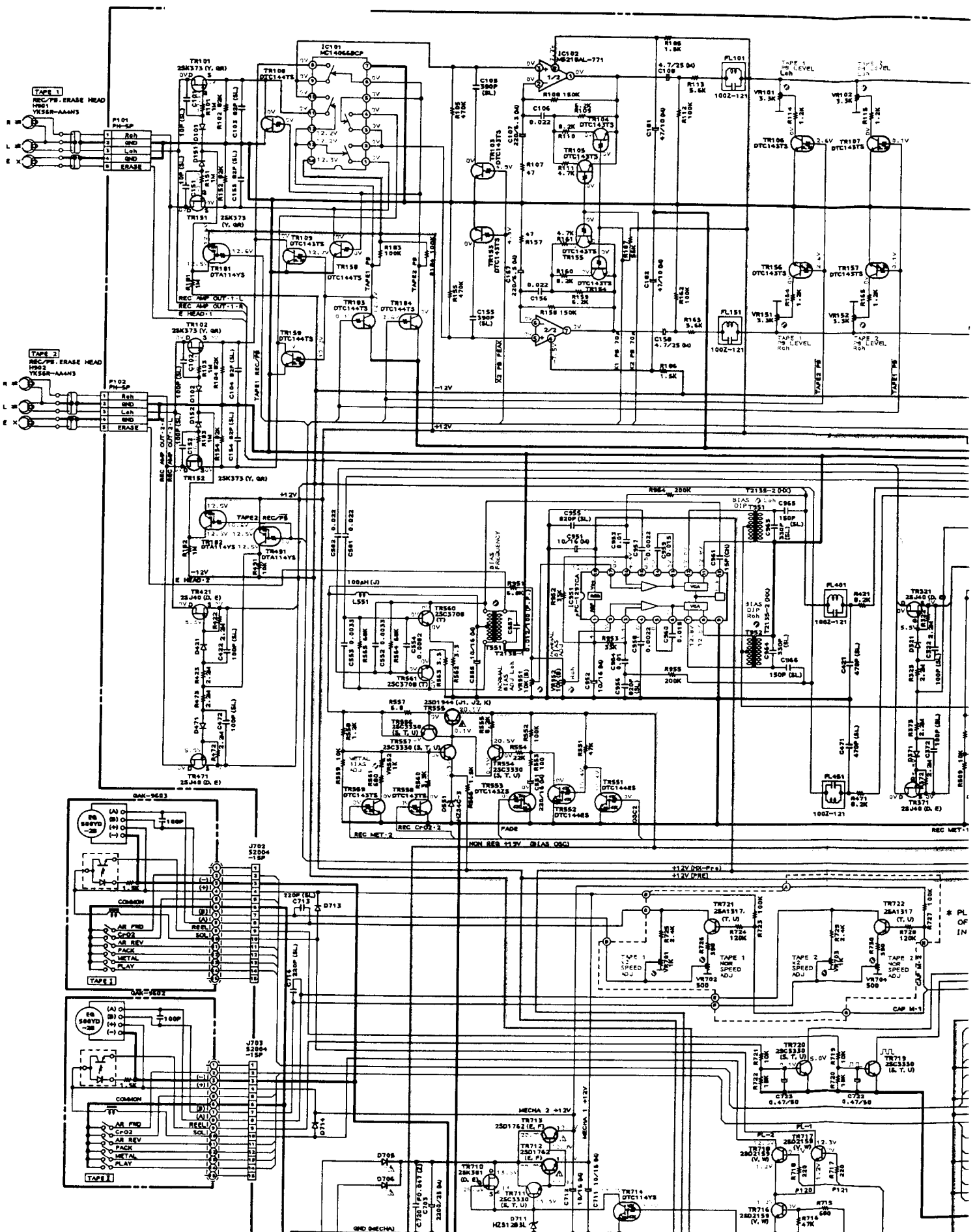

\* PL  
IN





(B) PCB T21 35A501B

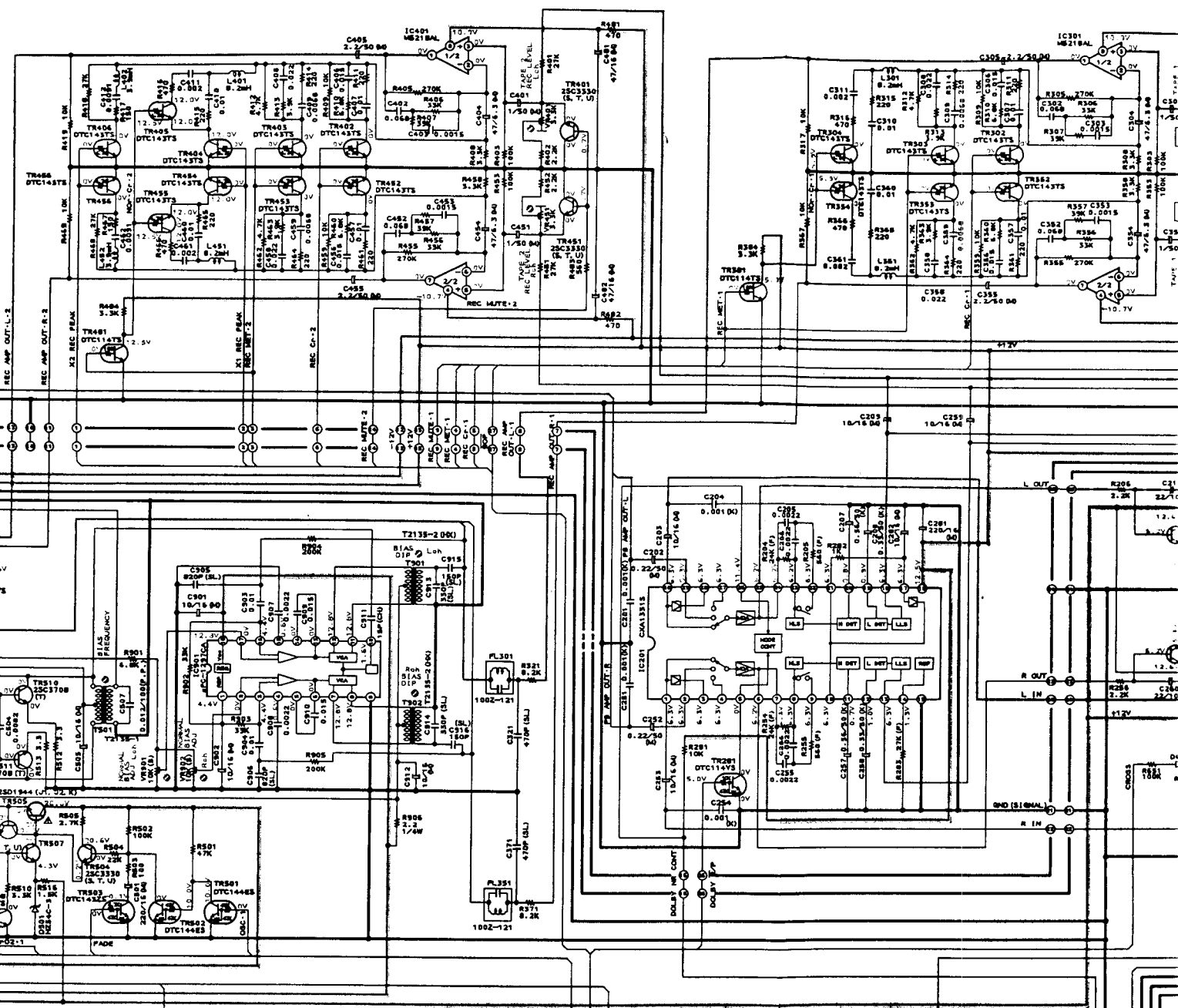

THERE ARE TWO TYPES OF THE CIRCUIT ENCLOSED IN THESE.

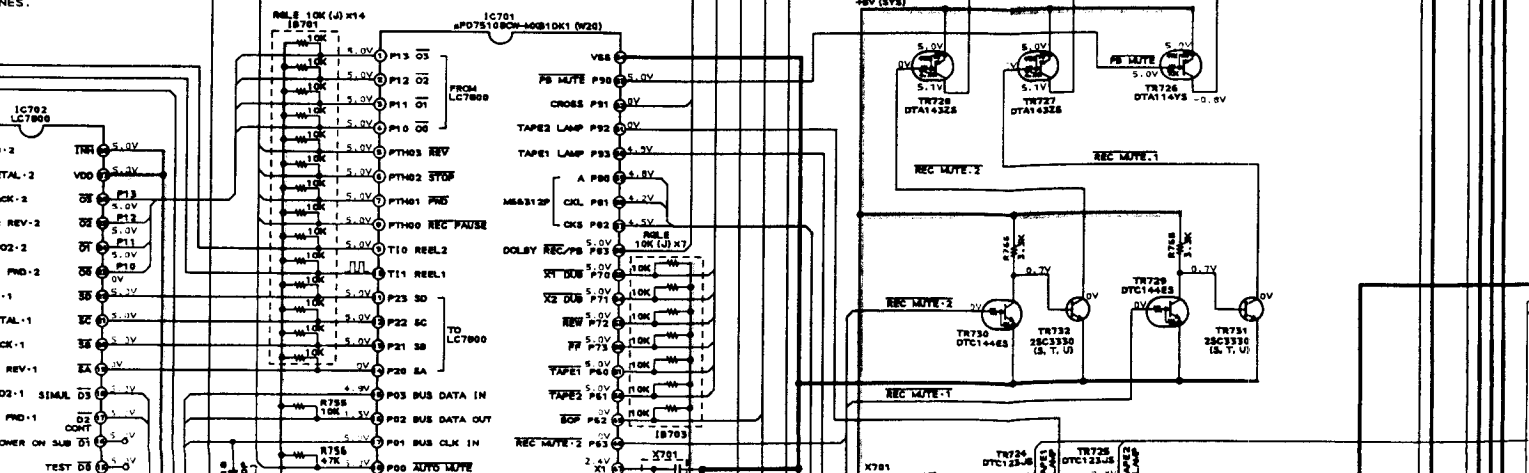



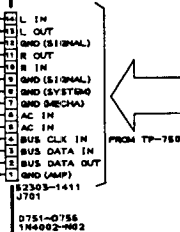
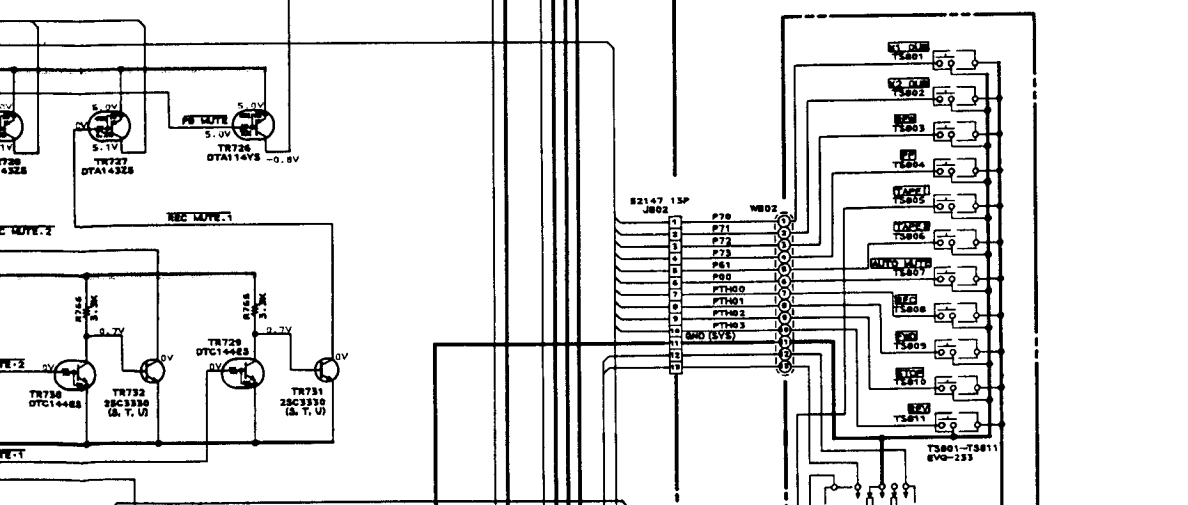
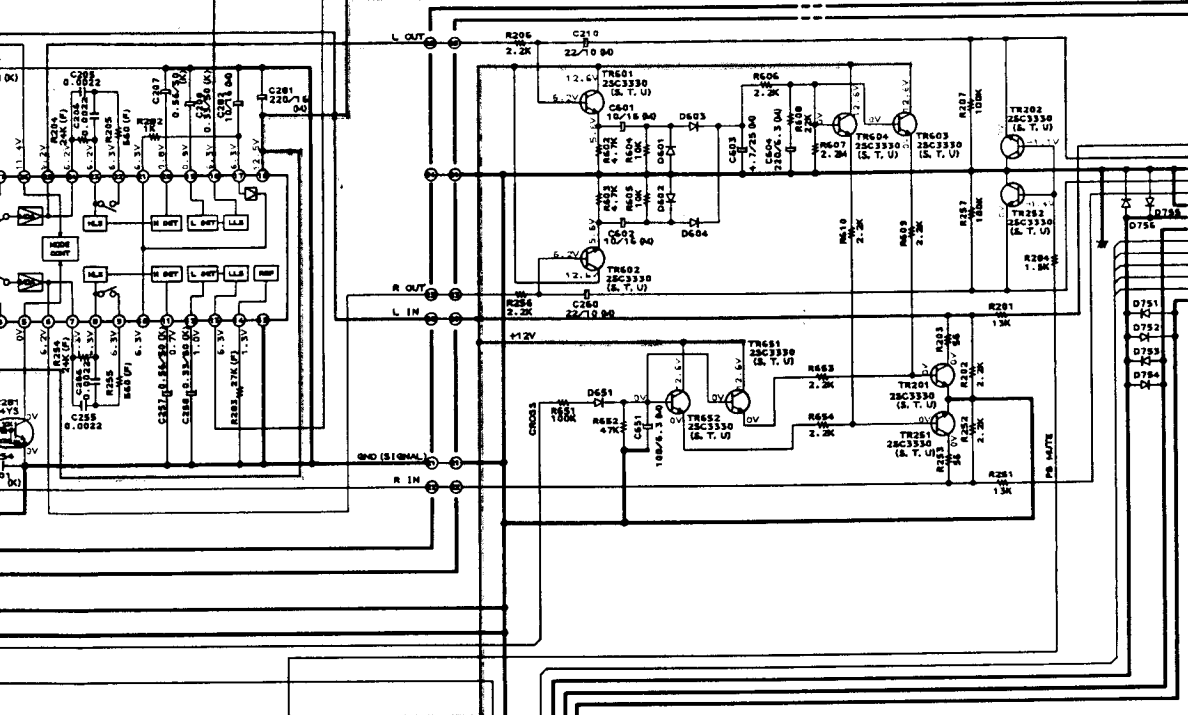
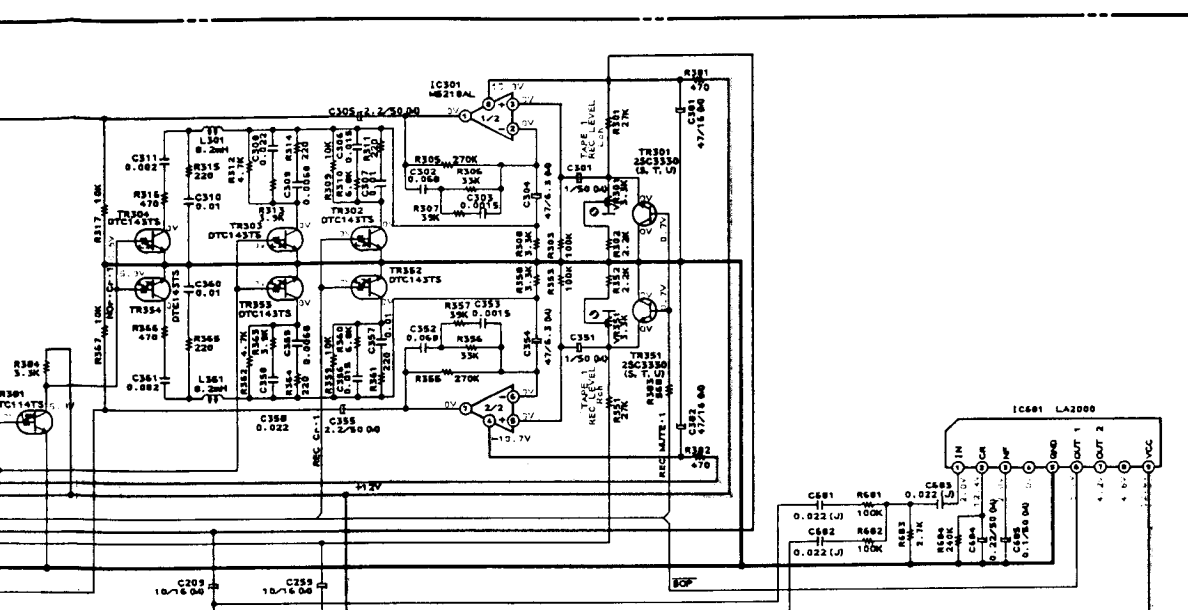

FROM TP-760

100-1000

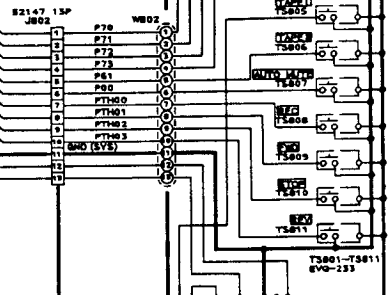

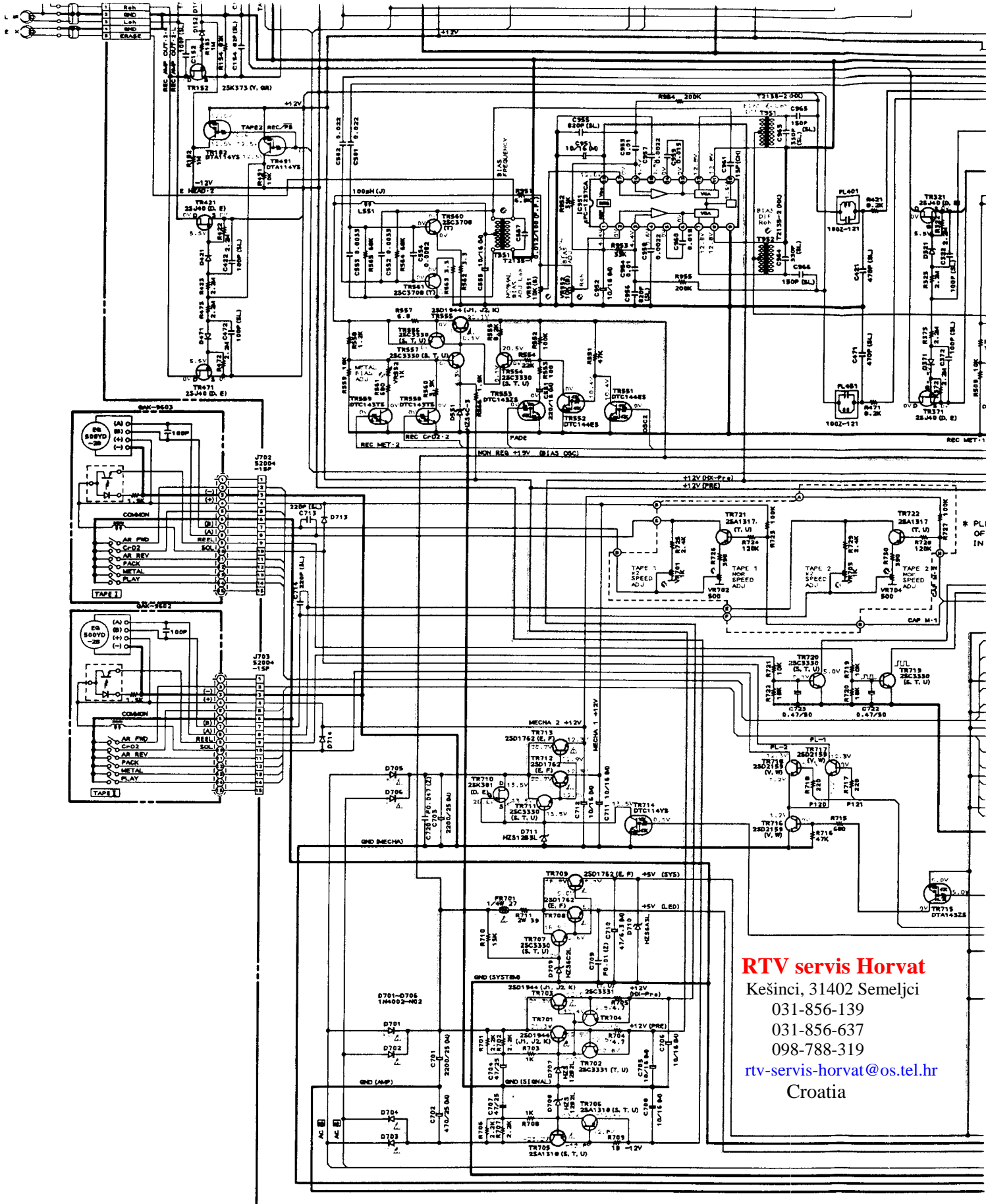

**RTV servis Horvat**  
 Kešinci, 31402 Semeljci  
 031-856-139  
 031-856-637  
 098-788-319  
[rtv-servis-horvat@os.tel.hr](mailto:rtv-servis-horvat@os.tel.hr)  
 Croatia

4 DECK (A) PCB T2135A501A

--- POWER SUPPLY LINE  
 --- SIGNAL LINE  
 --- REC SIGNAL LINE

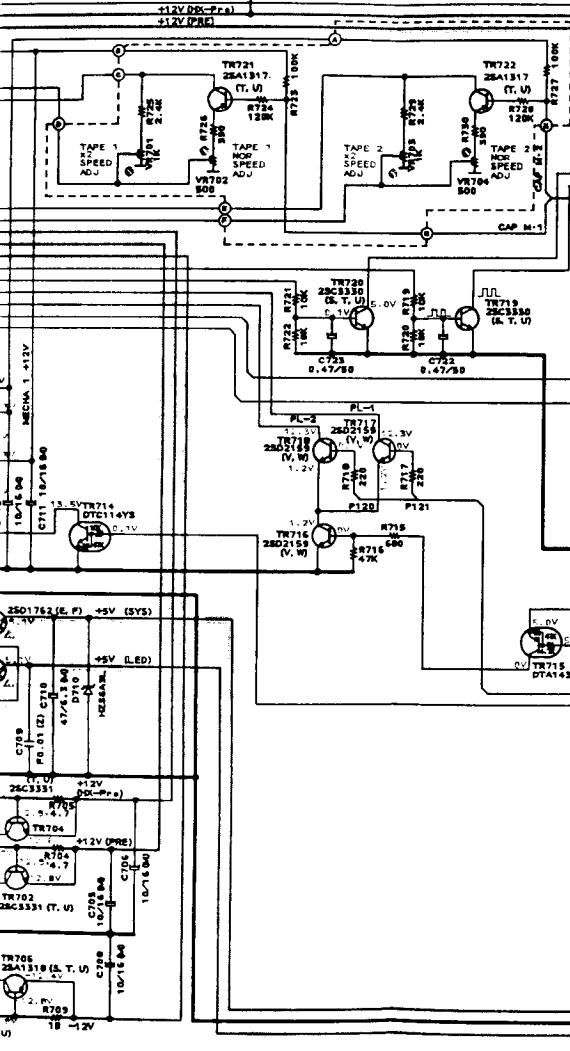
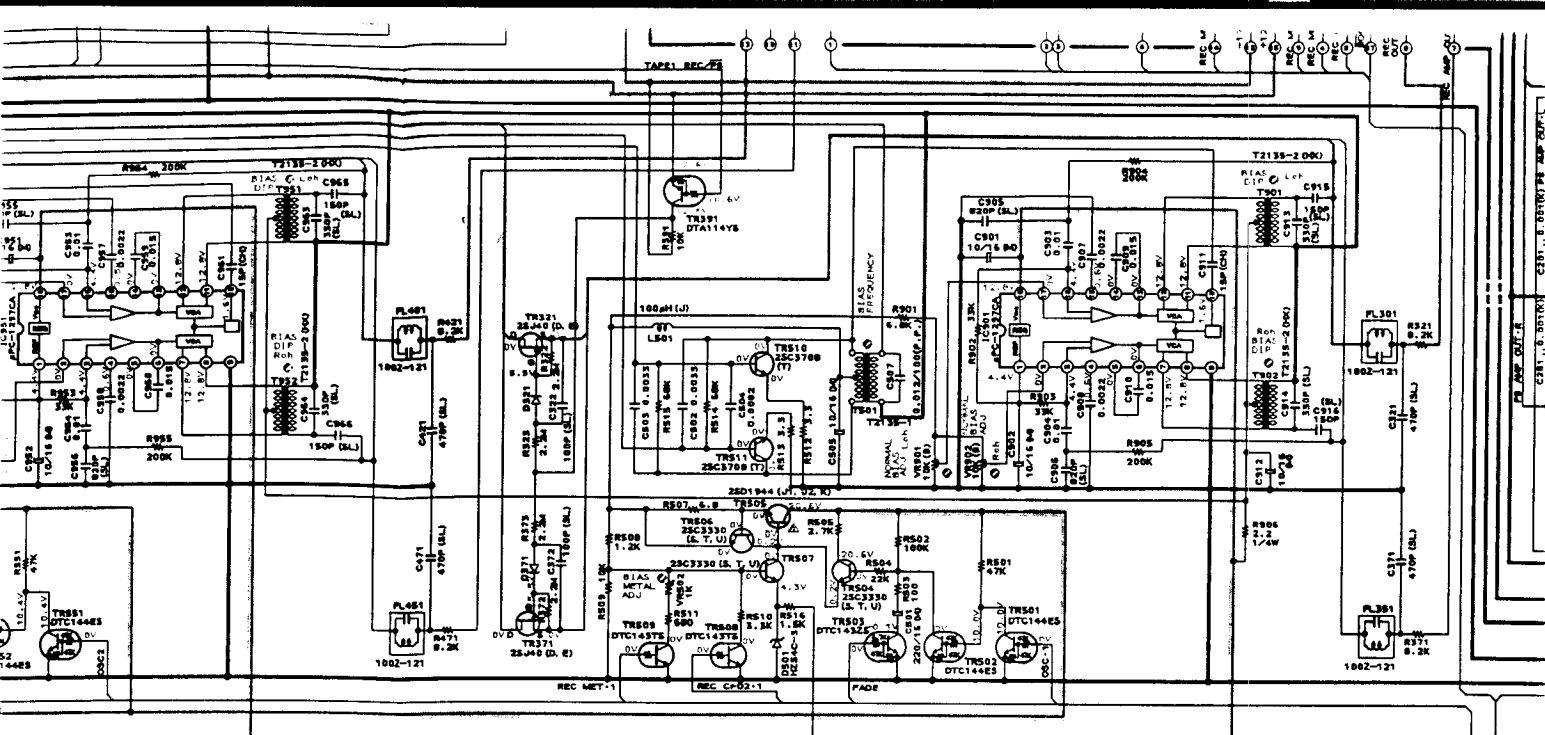

\* PLEASE NOTE THAT THERE ARE TWO TYPES OF CIRCUITS FOR THE CIRCUIT ENCLOSED IN THE DOTTED LINES.

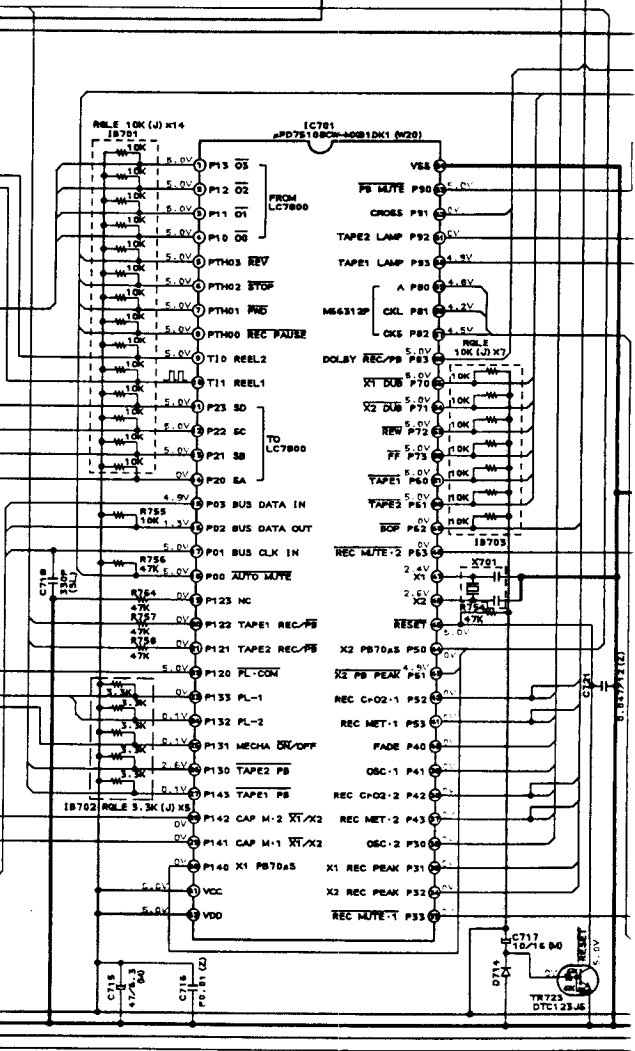
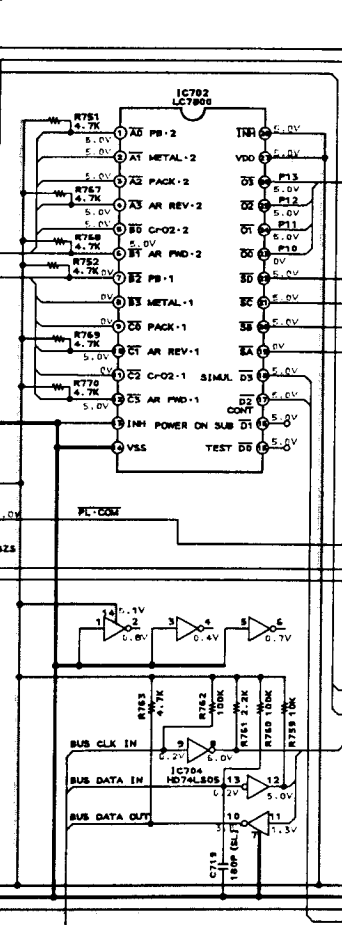

(POWER SUPPLY) LINE  
 (SIGNAL) LINE  
 (REC SIGNAL) LINE

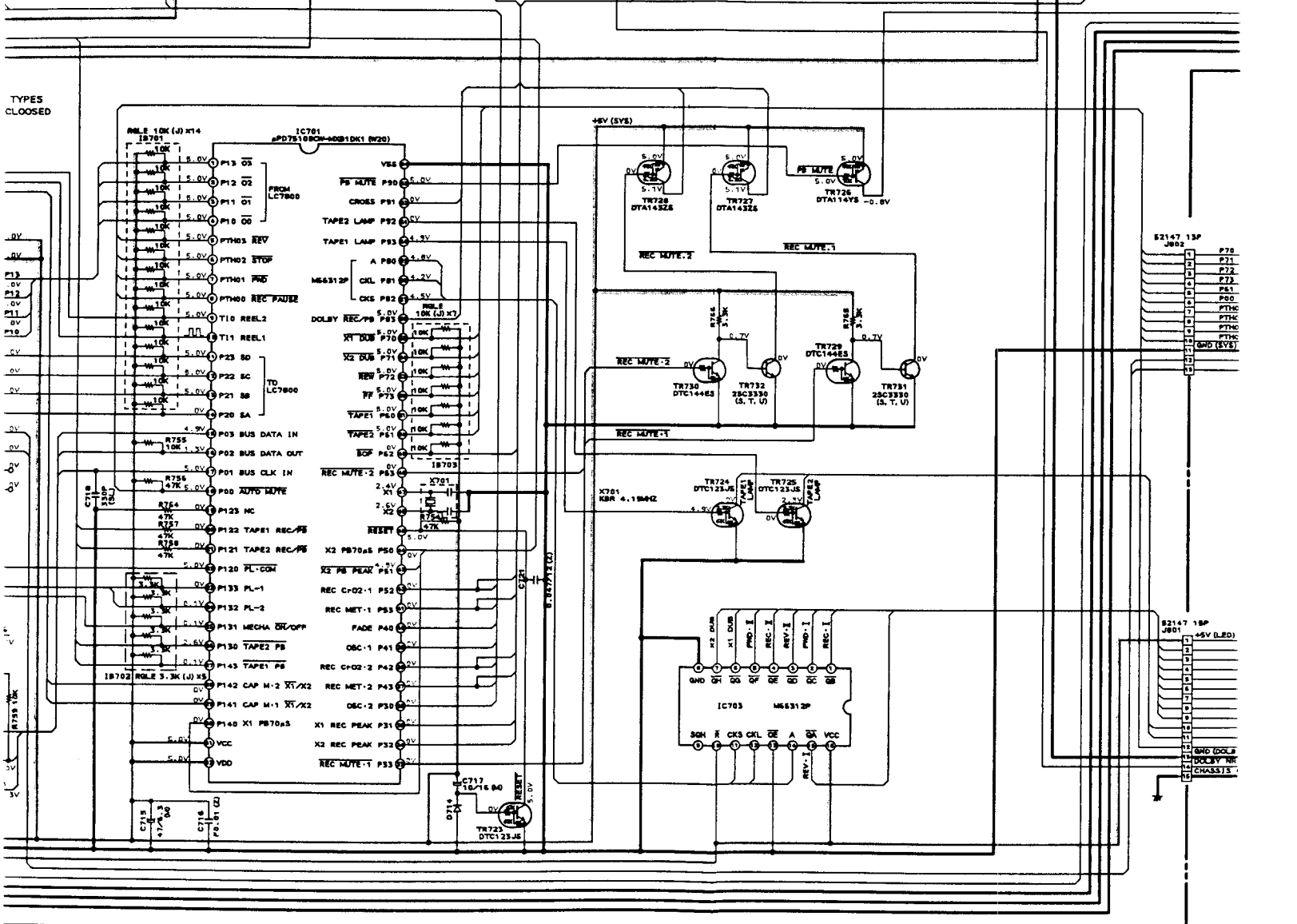
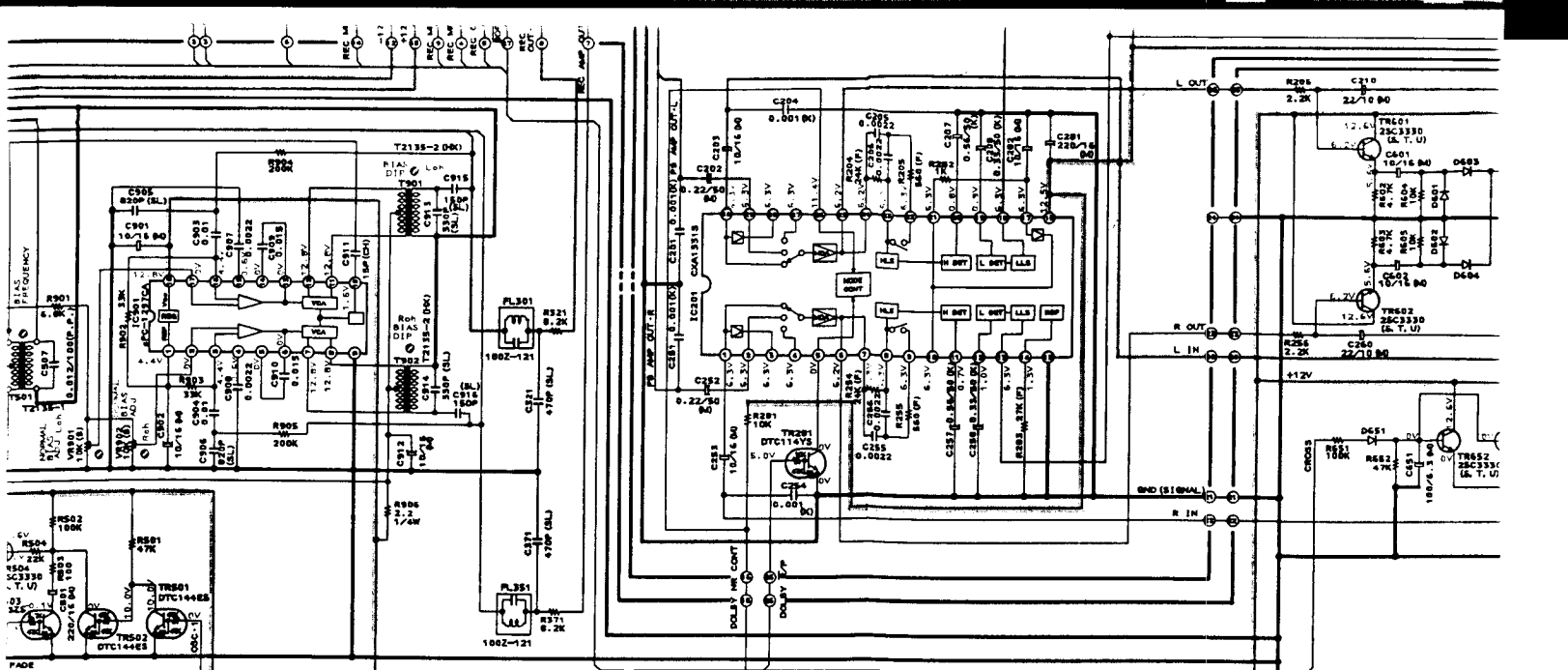

NOTE  
 UNLESS OTHERWISE SPECIFIED  
 ALL RESISTORS IN OHMS  
 ALL CAPACITORS IN PF  
 ALL DIODES ARE 1N5111T

INDICATED VOLTAGES WERE MEASURED DURING PB MODE  
 (CONDITIO-TAPE I, FWD PLAY, NORMAL TAPE, DOLBY OFF)

WARNING: ⚠ AND ⚡ INDICATE SAFETY CRITICAL COMPONENTS FOR CONTINUED SAFETY. REPLACE SAFETY CRITICAL COMPONENTS ONLY WITH MANUFACTURER'S RECOMMENDED PARTS

AVERTISSEMENT: ⚠ ET ⚡ ILS INDICENT LES COMPOSANTS CRITIQUES DE SÉCURITÉ. POUR MAINTENIR LE DEGRÉ DE SÉCURITÉ DE L'APPAREIL, NE REMPLACER QUE DES PIÈCES RECOMMANDÉES PAR LE FABRICANT

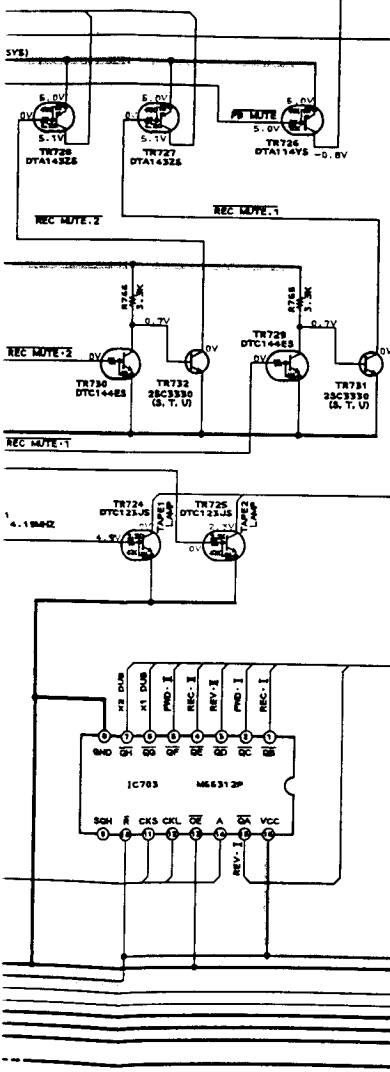
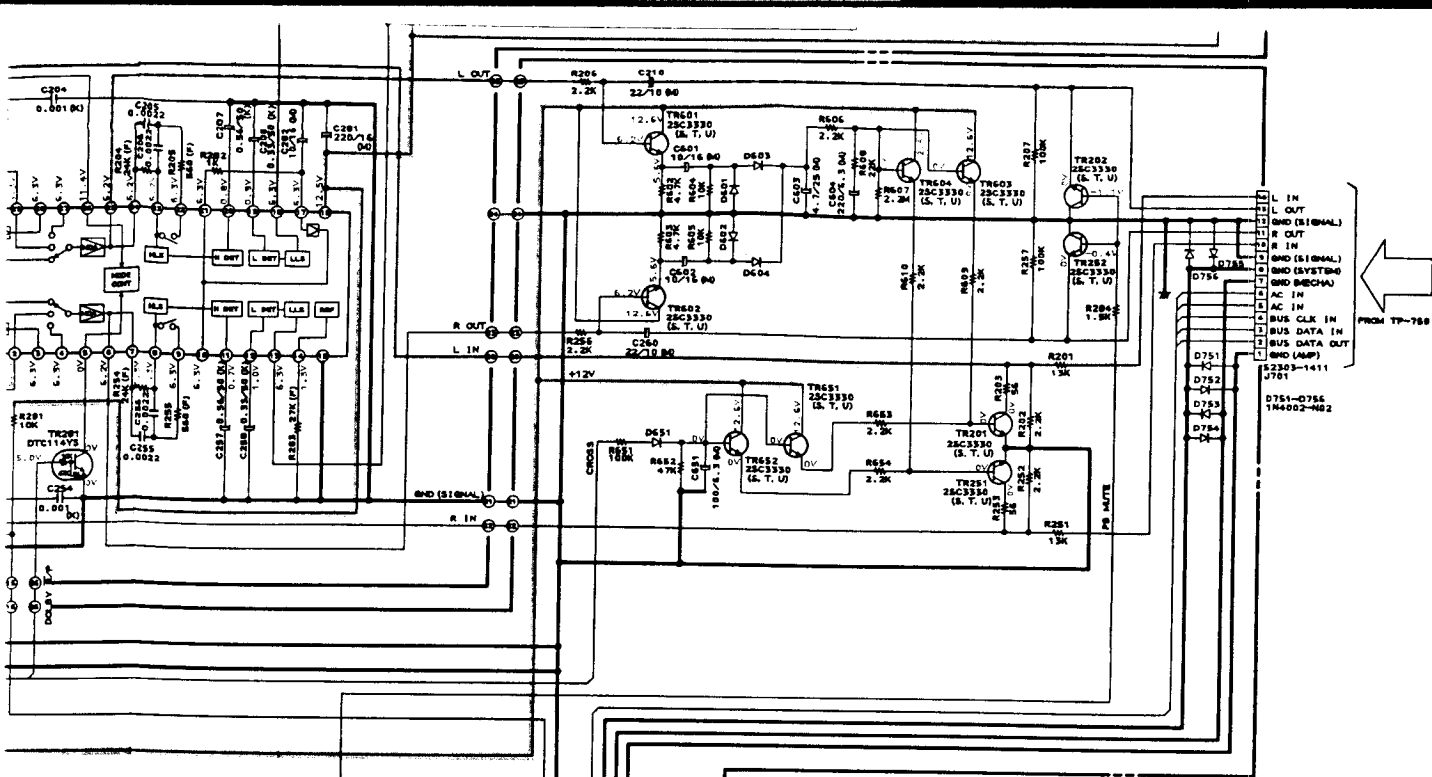

**RTV servis Horvat**  
 Kešinci, 31402 Semeljci  
 031-856-139  
 031-856-637  
 098-788-319  
[rtv-servis-horvat@os.teh.hr](mailto:rtv-servis-horvat@os.teh.hr)  
 Croatia

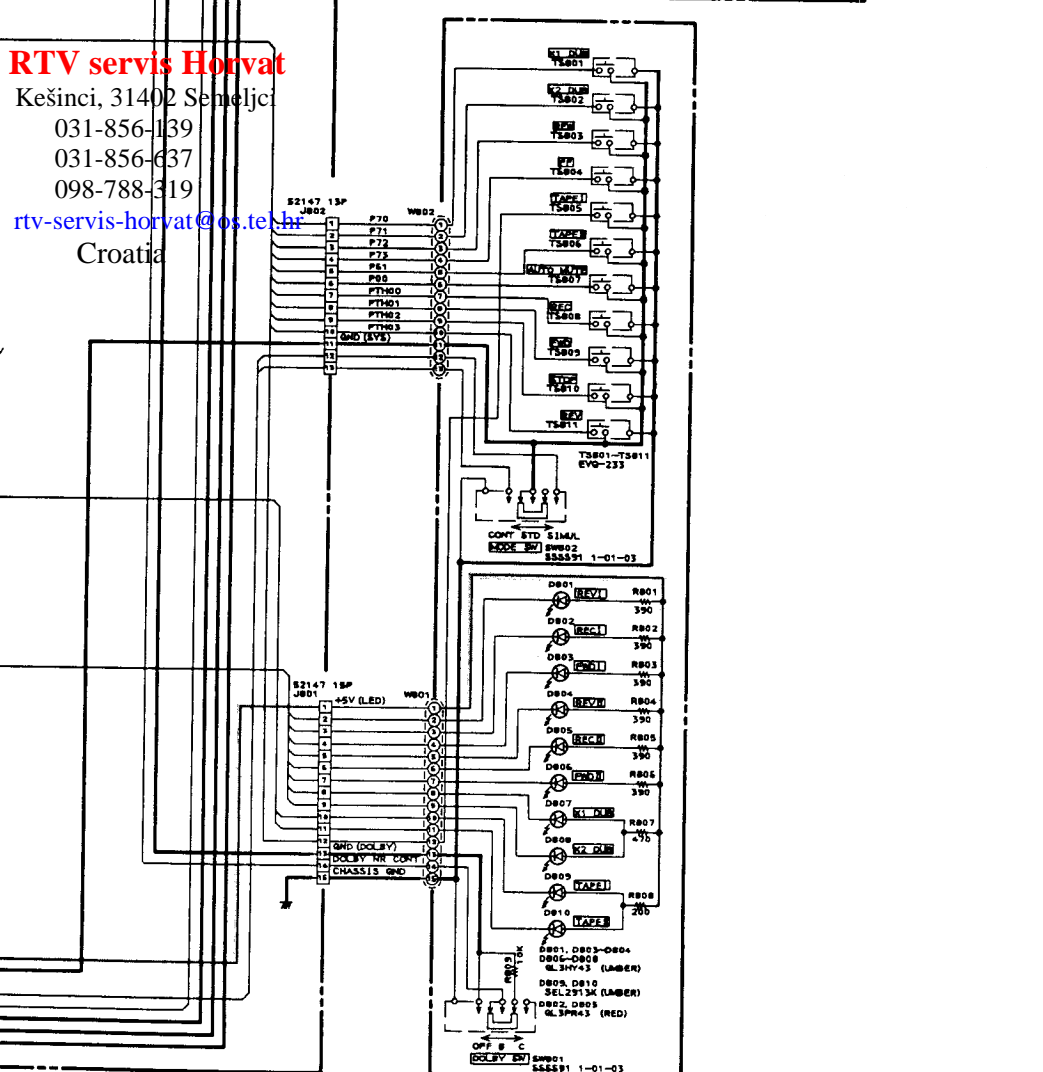

NOTE  
 UNLESS OTHERWISE SPECIFIED  
 ALL RESISTORS IN OHMS  
 ALL CAPACITORS IN PF  
 ALL DIODES ARE 1SS131T  
 INDICATED VOLTAGES WERE MEASURED DURING PB MODE  
 (CONDITION: TAPE 1, FWD PLAY, NORMAL TAPE, DOLBY OFF)

WARNING: A AND T INDICATE SAFETY CRITICAL COMPONENTS FOR CONTINUED SAFETY. REPLACE SAFETY CRITICAL COMPONENTS ONLY WITH MANUFACTURER'S RECOMMENDED PARTS  
 AVERTISSEMENT: A ET T ILS INDICENT LES COMPOSANTS CRITIQUES DE SECURITE. POUR MAINTENIR LE DEGRE DE SECURITE DE L'APPAREIL NE REMPLACER QUE DES PIECES RECOMMENDEES PAR LE FABRICANT

OPERATION PCB T2135A501C

# HX-950 SCHEMATIC DIAGRAM

No. 8-7 T213501M

\* ANOTHER TYPE

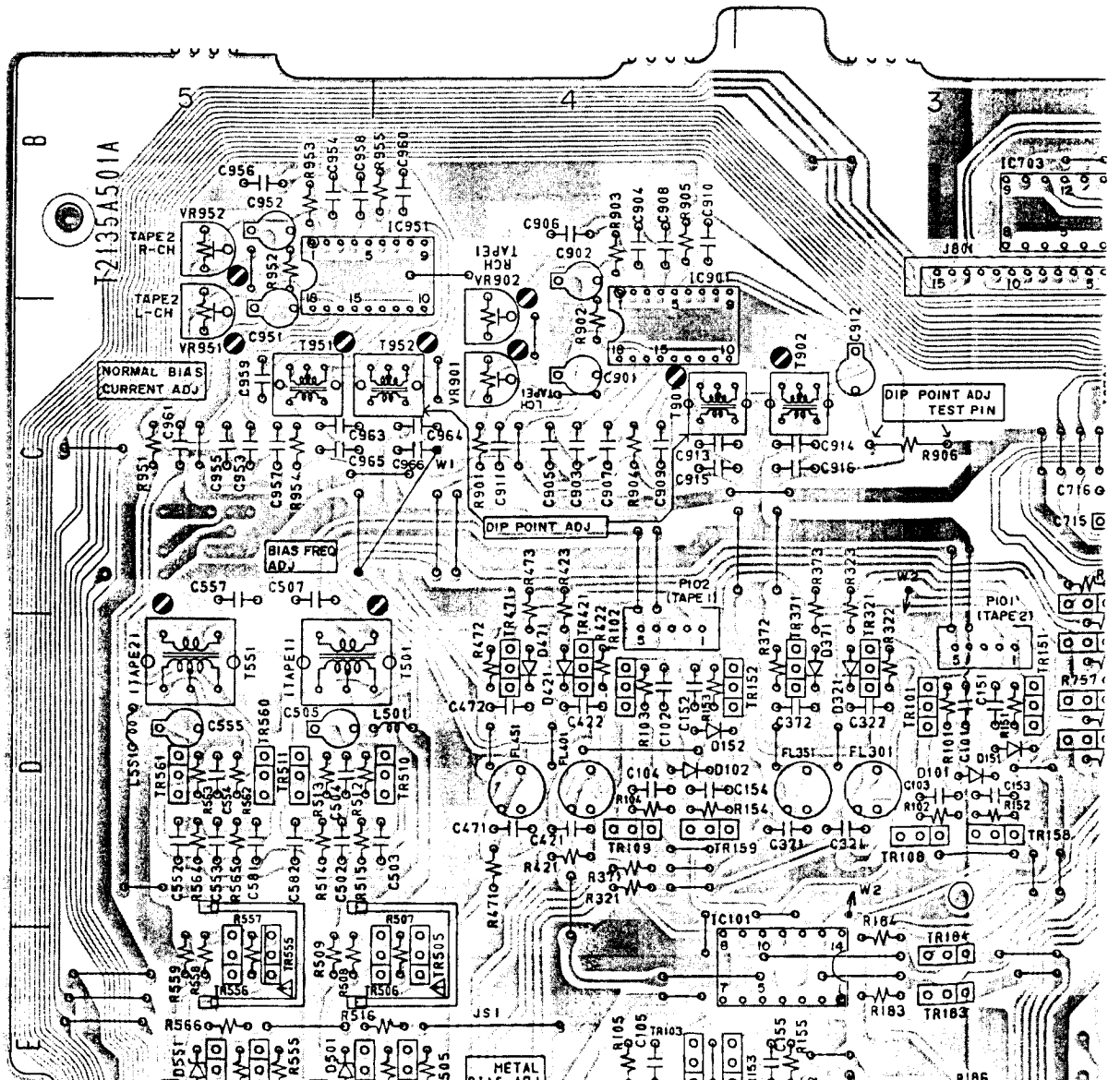
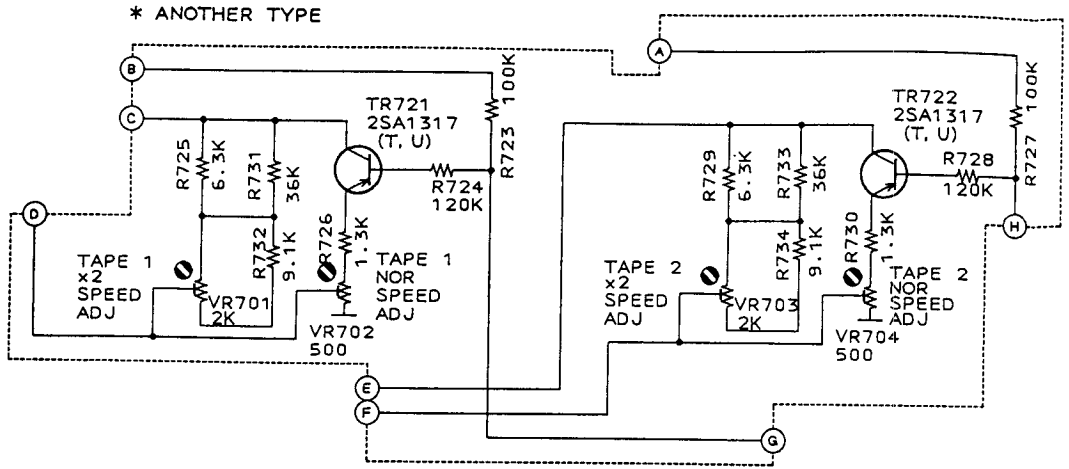

G  
H

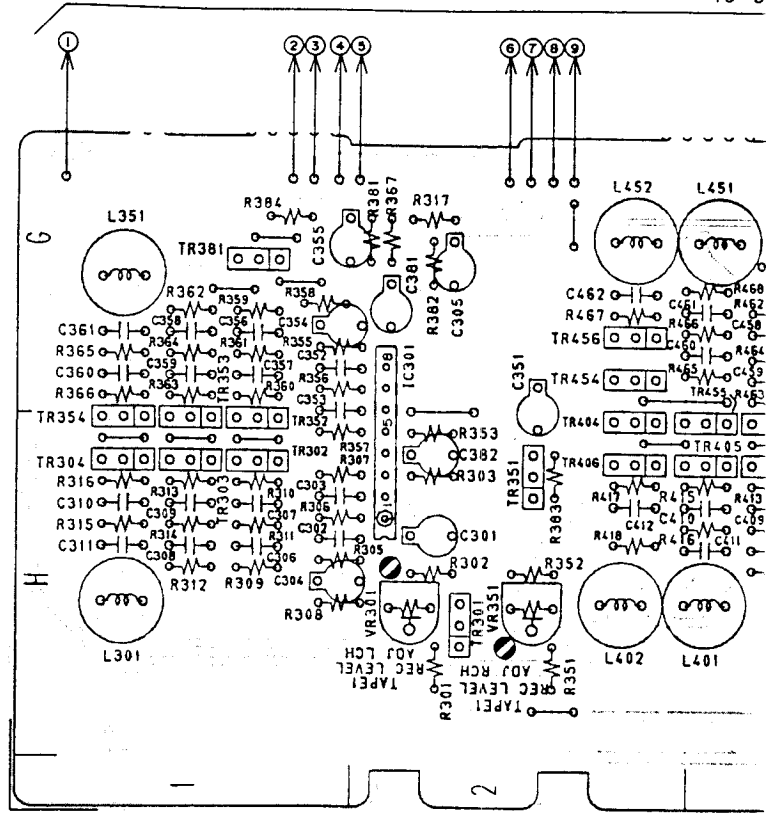
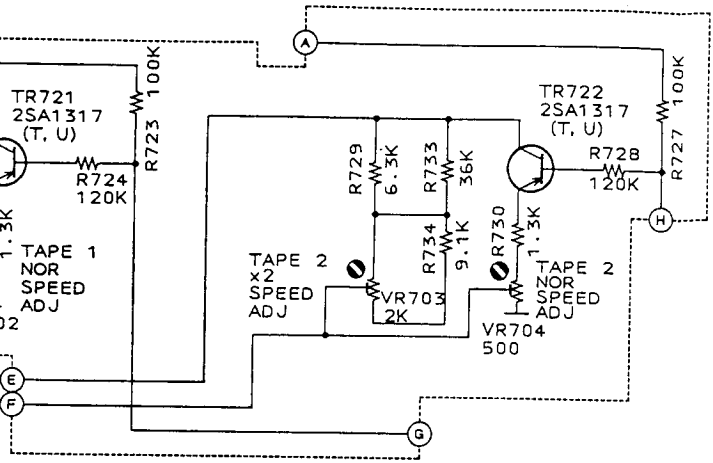

DECK (B)

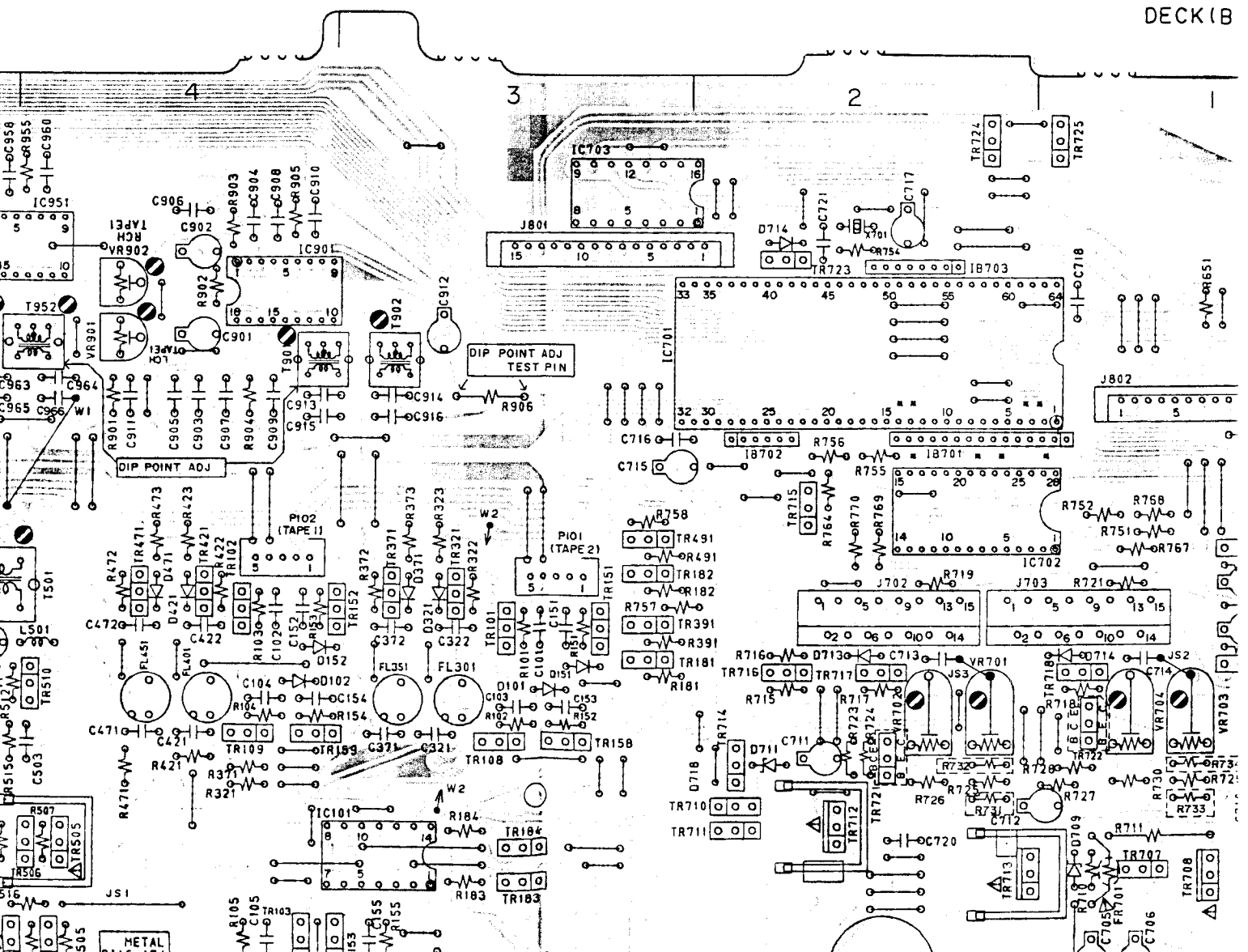



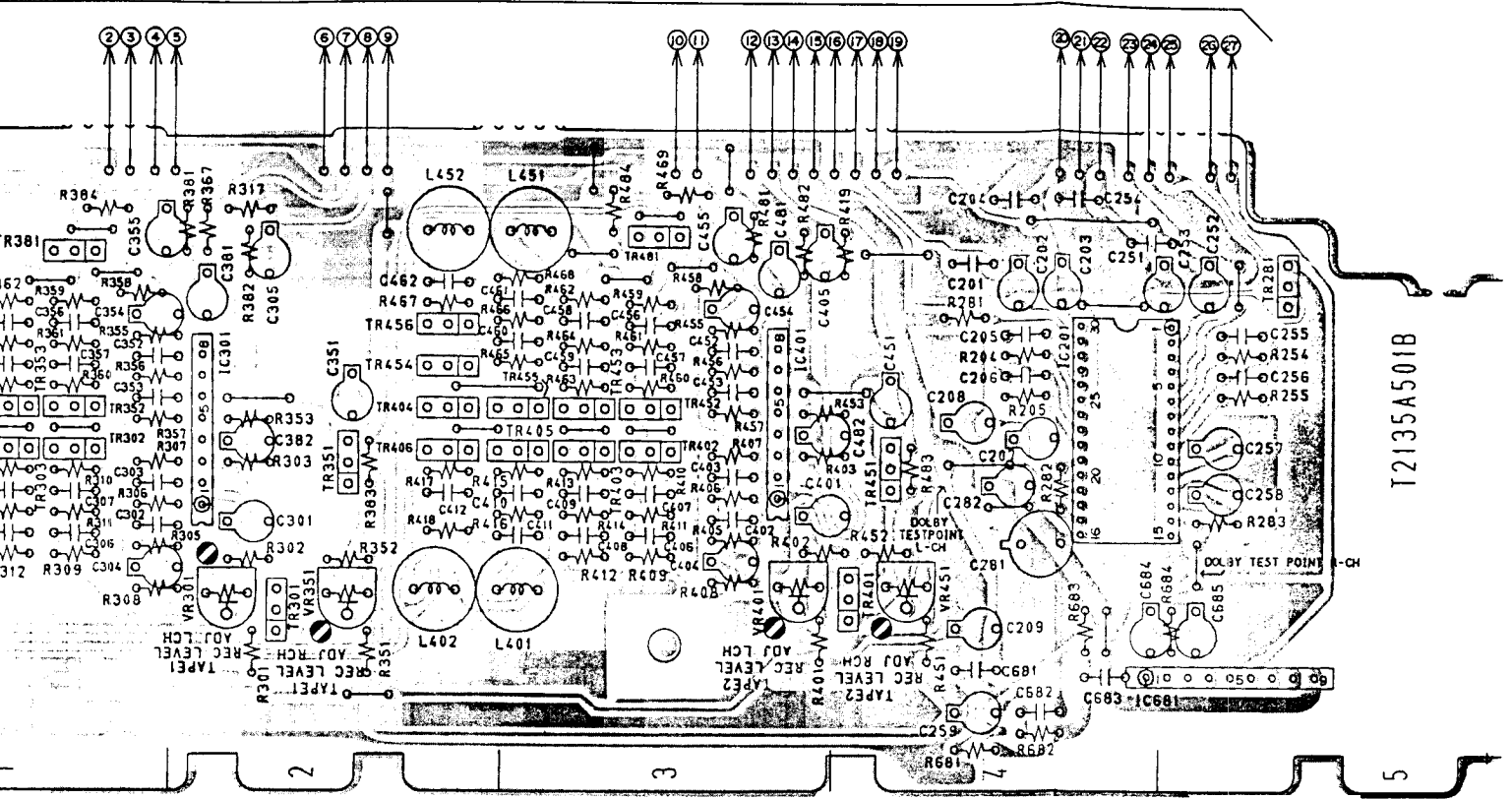

T2135A501B

DECK(B) PCB T2135A501B

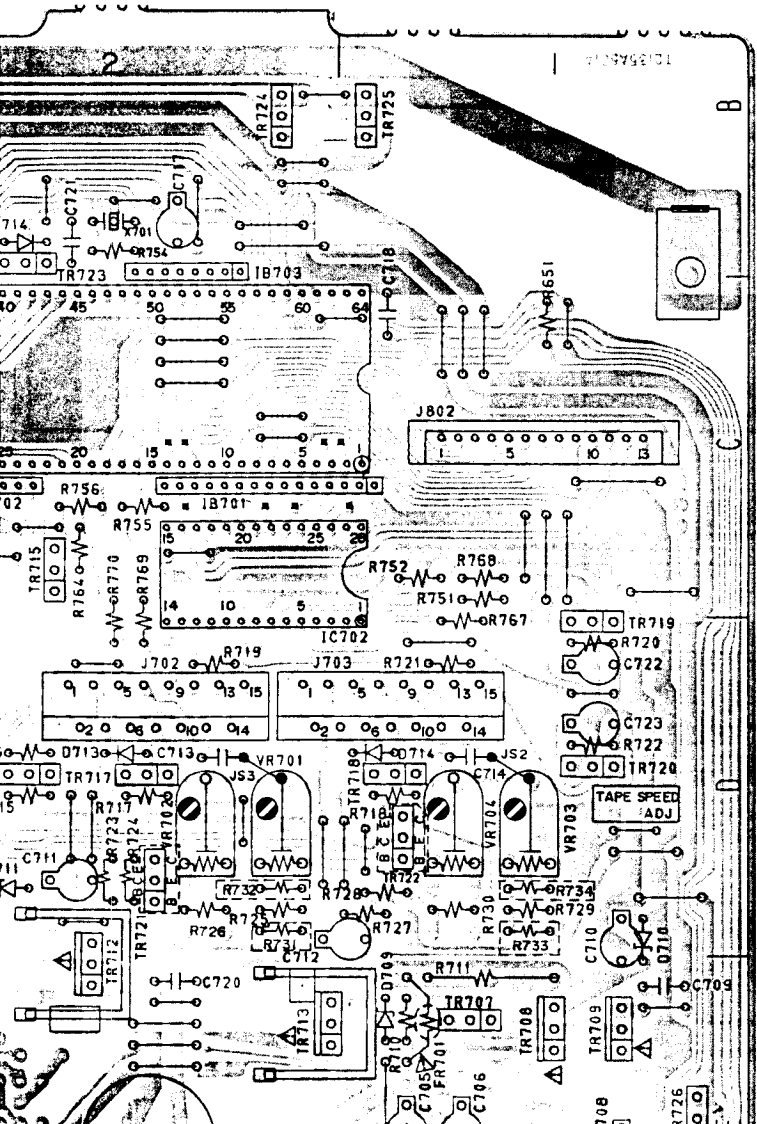

PRINCIPAL PARTS LOCATION

ICs			
IC101 .....	E3	TR506 .....	E4
IC102 .....	E3,4	TR507 .....	E5
IC701 .....	C2	TR508 .....	E5
IC702 .....	C1,2	TR509 .....	E5
IC703 .....	B3	TR510 .....	D5
IC704 .....	F1	TR511 .....	D5
IC901 .....	C4	TR551 .....	F5
IC951 .....	B4,5	TR552 .....	F5
		TR553 .....	E5
		TR554 .....	E5
		TR555 .....	E5
		TR556 .....	E5
		TR557 .....	E5
		TR558 .....	F5
		TR559 .....	F5
		TR560 .....	D5
		TR561 .....	D5
		TR601 .....	F3
		TR602 .....	F3
		TR603 .....	F3
		TR604 .....	F3
		TR651 .....	F2
		TR652 .....	F2
		TR701 .....	E1
		TR702 .....	E1
		TR703 .....	E1
		TR704 .....	E1
		TR705 .....	E1
		TR706 .....	E1
		TR707 .....	E1
		TR708 .....	E1
		TR709 .....	E1
		TR710 .....	D2
		TR711 .....	E2
		TR712 .....	D,E2
		TR713 .....	E1,2
		TR714 .....	D2
		TR715 .....	C2
		TR716 .....	D2
		TR717 .....	D2



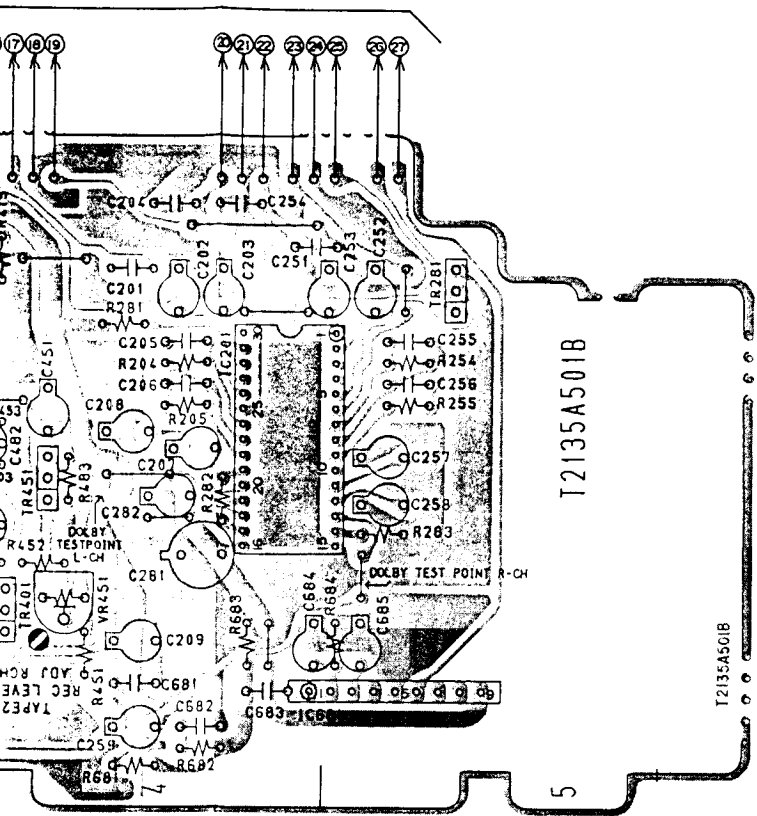

**PRINCIPAL PARTS LOCATION**

<b>ICs</b>			
IC201 .....	G,H4	TR381 .....	G1
IC301 .....	G,H2	TR401 .....	H4
IC401 .....	G,H3	TR402 .....	H3
IC681 .....	H4,5	TR403 .....	H3
		TR404 .....	G,H2
		TR405 .....	H3
<b>TRANSISTORS</b>			
TR281 .....	G5	TR406 .....	H2
TR301 .....	H2	TR451 .....	H4
TR302 .....	H1	TR452 .....	G,H3
TR303 .....	H1	TR453 .....	G,H3
TR304 .....	H1	TR454 .....	G2
TR351 .....	H2	TR455 .....	G,H3
TR352 .....	G,H1	TR456 .....	G2
TR353 .....	G,H1	TR481 .....	G3
TR354 .....	G,H1		

01B

**PRINCIPAL PARTS LOCATION**

1 .....	E3	TR506 .....	E4
2 .....	E3,4	TR507 .....	E5
1 .....	C2	TR508 .....	E5
2 .....	C1,2	TR509 .....	E5
3 .....	B3	TR510 .....	D5
4 .....	F1	TR511 .....	D5
1 .....	C4	TR551 .....	F5
1 .....	B4,5	TR552 .....	F5
		TR553 .....	E5
		TR554 .....	E5
		TR555 .....	E5
		TR556 .....	E5
		TR557 .....	E5
		TR558 .....	F5
		TR559 .....	F5
		TR560 .....	D5
		TR561 .....	D5
		TR601 .....	F3
		TR602 .....	F3
		TR603 .....	F3
		TR604 .....	F3
		TR651 .....	F2
		TR652 .....	F2
		TR701 .....	E1
		TR702 .....	E1
		TR703 .....	E1
		TR704 .....	E1
		TR705 .....	E1
		TR706 .....	E1
		TR707 .....	E1
		TR708 .....	E1
		TR709 .....	E1
		TR710 .....	D2
		TR711 .....	E2
		TR712 .....	D,E2
		TR713 .....	E1,2
		TR714 .....	D2
		TR715 .....	C2
		TR716 .....	D2
		TR717 .....	D2

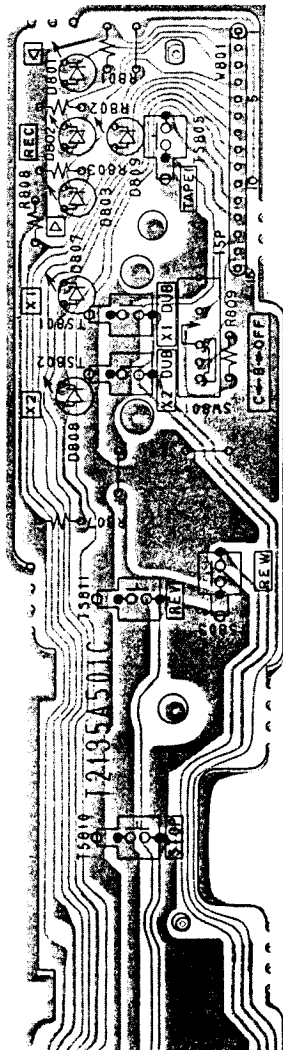

OPERATION PCB T2135A501C

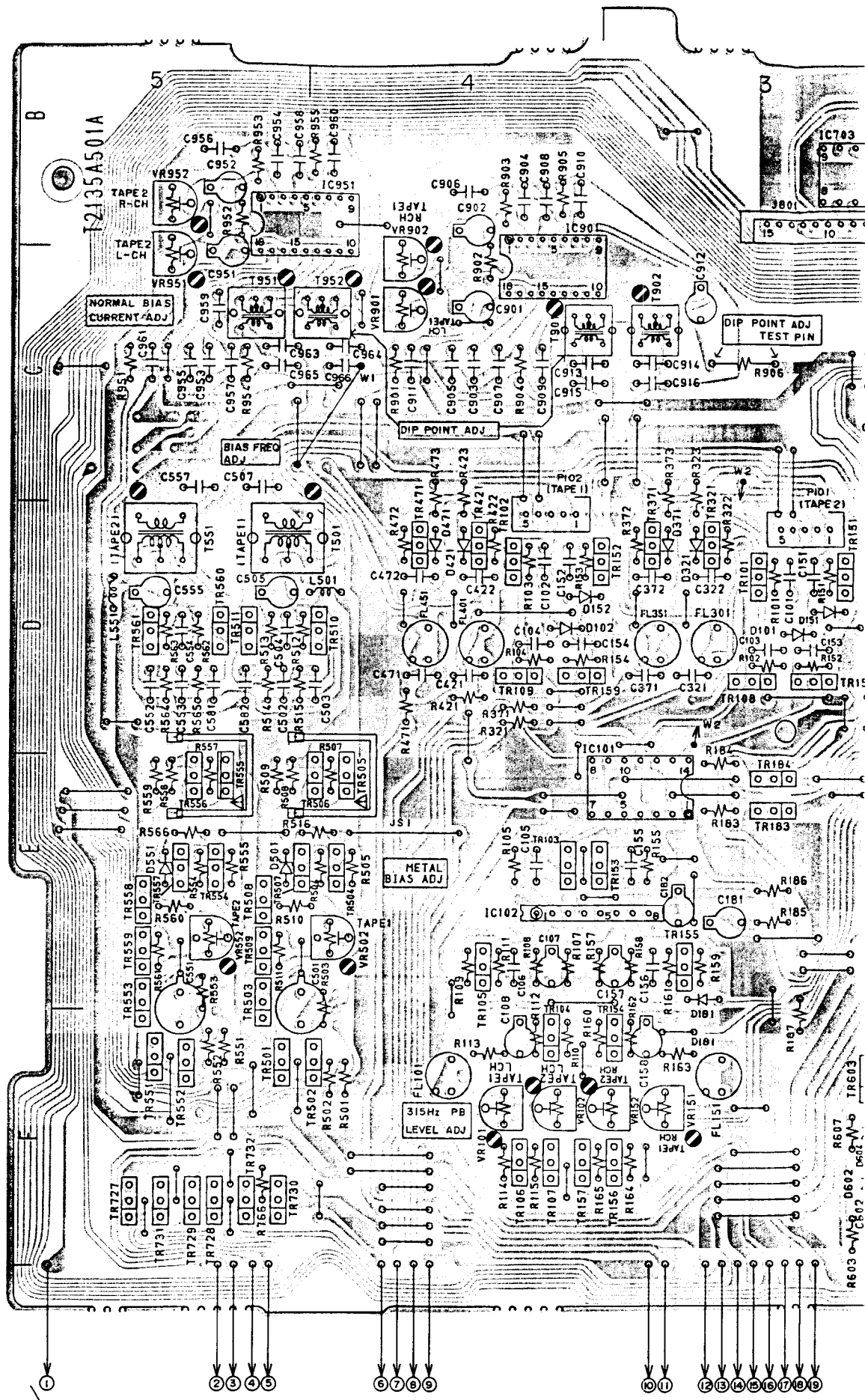

TO DECK (B) PCB

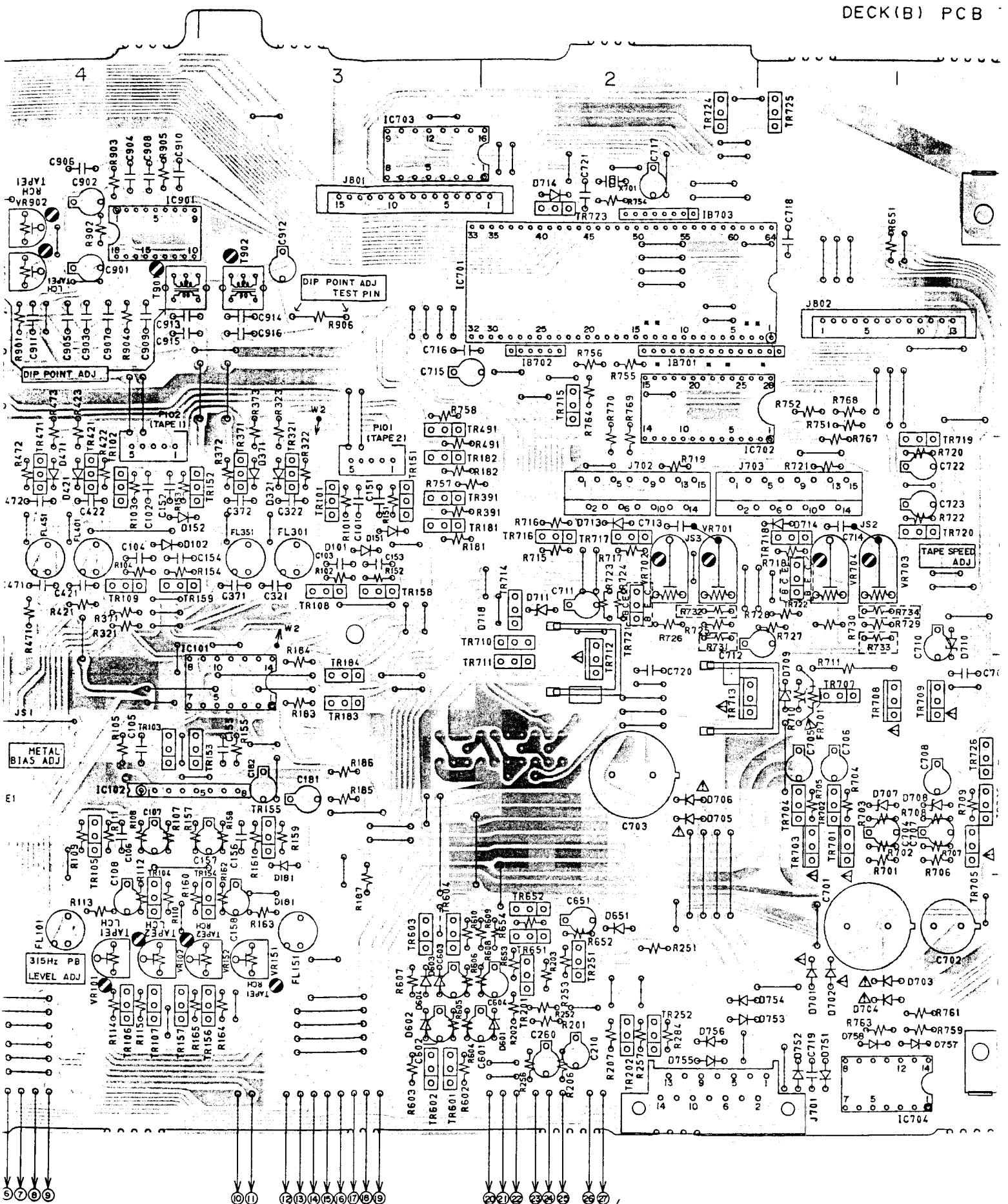

NOTE : REFER TO SCHEMATIC DIAGRAMS F PARTS ENCLOSED IN DOTTED LINES

DECK(B) PCB T2135A501B

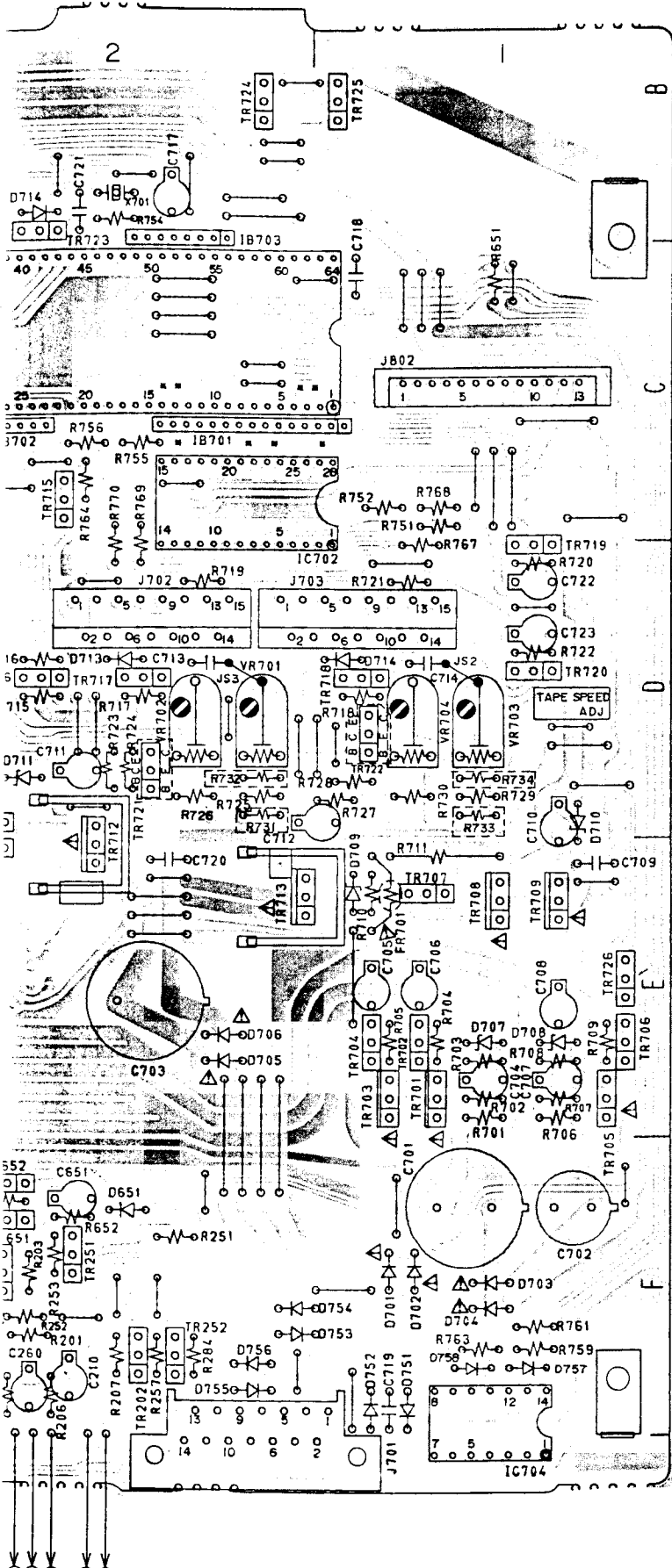

PRINCIPAL PARTS LOCATION

ICs					
IC101	.....	E3	TR506	.....	E4
IC102	.....	E3,4	TR507	.....	E5
IC701	.....	C2	TR508	.....	E5
IC702	.....	C1,2	TR509	.....	E5
IC703	.....	B3	TR510	.....	D5
IC704	.....	F1	TR511	.....	D5
IC901	.....	C4	TR551	.....	F5
IC951	.....	B4,5	TR552	.....	F5
			TR553	.....	E5
			TR554	.....	E5
			TR555	.....	E5
			TR556	.....	E5
			TR557	.....	E5
			TR558	.....	F5
			TR559	.....	F5
			TR560	.....	D5
			TR561	.....	D5
			TR601	.....	F3
			TR602	.....	F3
			TR603	.....	F3
			TR604	.....	F3
			TR651	.....	F2
			TR652	.....	F2
			TR701	.....	E1
			TR702	.....	E1
			TR703	.....	E1
			TR704	.....	E1
			TR705	.....	E1
			TR706	.....	E1
			TR707	.....	E1
			TR708	.....	E1
			TR709	.....	E1
			TR710	.....	D2
			TR711	.....	E2
			TR712	.....	D,E2
			TR713	.....	D1,2
			TR714	.....	E2
			TR715	.....	C2
			TR716	.....	D2
			TR717	.....	D2
			TR718	.....	D1
			TR719	.....	D1
			TR720	.....	D1
			TR721	.....	D2
			TR722	.....	D1
			TR723	.....	B2
			TR724	.....	B2
			TR725	.....	B1
			TR726	.....	E1
			TR727	.....	F5
			TR728	.....	F5
			TR729	.....	F5
			TR730	.....	F5
			TR731	.....	F5
			TR732	.....	F5
CONNECTORs					
J701	.....	F1,2			
J702	.....	D2			
J703	.....	D1,2			
J801	.....	B3			
J802	.....	C1			
P101	.....	D3			
P102	.....	D4			
TRANSISTORs					
TR101	.....	D3			
TR102	.....	D4			
TR103	.....	E4			
TR104	.....	F4			
TR105	.....	E4			
TR106	.....	F4			
TR107	.....	F4			
TR108	.....	D3			
TR109	.....	D4			
TR151	.....	D3			
TR152	.....	D3			
TR153	.....	E3			
TR154	.....	F3			
TR155	.....	E3			
TR156	.....	F3			
TR157	.....	F4			
TR158	.....	D3			
TR159	.....	D4			
TR181	.....	D3			
TR182	.....	D3			
TR183	.....	E3			
TR184	.....	E3			
TR201	.....	F2			
TR202	.....	F2			
TR251	.....	F2			
TR252	.....	F2			
TR321	.....	D3			
TR371	.....	D3			
TR391	.....	D3			
TR421	.....	D4			
TR471	.....	D4			
TR491	.....	C3			
TR501	.....	F5			
TR502	.....	F4			
TR503	.....	E,F5			
TR504	.....	E4			
TR505	.....	E4			

WARNING:  $\Delta$  INDICATES SAFETY CRITICAL COMPONENTS. FOR CONTINUED SAFETY, REPLACE SAFETY CRITICAL COMPONENTS ONLY WITH MANUFACTURER'S RECOMMENDED PARTS.

AVERTISSEMENT:  $\Delta$  IL INDIQUE LES COMPOSANTS CRITIQUES DE SÉCURITÉ. POUR MAINTENIR LE DEGRÉ DE SÉCURITÉ DE L'APPAREIL, NE REMPLACER QUE DES PIÈCES RECOMMANDÉES PAR LE FABRICANT.

NOTE : REFER TO SCHEMATIC DIAGRAMS FOR PARTS ENCLOSED IN DOTTED LINES.

PRINCIPAL PARTS LOCATION

ICs

IC101	.....	E3
IC102	.....	E3,4
IC701	.....	C2
IC702	.....	C1,2
IC703	.....	B3
IC704	.....	F1
IC901	.....	C4
IC951	.....	B4,5

CONNECTORS

J701	.....	F1,2
J702	.....	D2
J703	.....	D1,2
J801	.....	B3
J802	.....	C1
P101	.....	D3
P102	.....	D4

TRANSISTORS

TR101	.....	D3
TR102	.....	D4
TR103	.....	E4
TR104	.....	F4
TR105	.....	E4
TR106	.....	F4
TR107	.....	F4
TR108	.....	D3
TR109	.....	D4
TR151	.....	D3
TR152	.....	D3
TR153	.....	E3
TR154	.....	F3
TR155	.....	E3
TR156	.....	F3
TR157	.....	F4
TR158	.....	D3
TR159	.....	D4
TR181	.....	D3
TR182	.....	D3
TR183	.....	E3
TR184	.....	E3
TR201	.....	F2
TR202	.....	F2
TR251	.....	F2
TR252	.....	F2
TR321	.....	D3
TR371	.....	D3
TR391	.....	D3
TR421	.....	D4
TR471	.....	D4
TR491	.....	C3
TR501	.....	F5
TR502	.....	F4
TR503	.....	E,F5
TR504	.....	E4
TR505	.....	E4
TR506	.....	E4
TR507	.....	E5
TR508	.....	E5
TR509	.....	E5
TR510	.....	D5
TR511	.....	D5
TR551	.....	F5
TR552	.....	F5
TR553	.....	E5
TR554	.....	E5
TR555	.....	E5
TR556	.....	E5
TR557	.....	E5
TR558	.....	F5
TR559	.....	F5
TR560	.....	D5
TR561	.....	D5
TR601	.....	F3
TR602	.....	F3
TR603	.....	F3
TR604	.....	F3
TR651	.....	F2
TR652	.....	F2
TR701	.....	E1
TR702	.....	E1
TR703	.....	E1
TR704	.....	E1
TR705	.....	E1
TR706	.....	E1
TR707	.....	E1
TR708	.....	E1
TR709	.....	E1
TR710	.....	D2
TR711	.....	E2
TR712	.....	D,E2
TR713	.....	E1,2
TR714	.....	D2
TR715	.....	C2
TR716	.....	D2
TR717	.....	D2
TR718	.....	D1
TR719	.....	D1
TR720	.....	D1
TR721	.....	D2
TR722	.....	D1
TR723	.....	B2
TR724	.....	B2
TR725	.....	B1
TR726	.....	E1
TR727	.....	F5
TR728	.....	F5
TR729	.....	F5
TR730	.....	F5
TR731	.....	F5
TR732	.....	F5

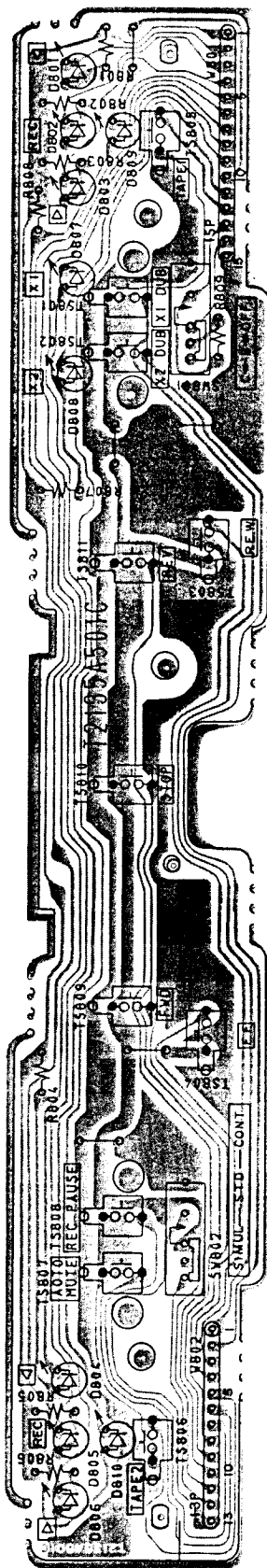

OPERATION PCB T2135A501C

WARNING: Δ INDICATES SAFETY CRITICAL COMPONENTS. FOR CONTINUED SAFETY, REPLACE SAFETY CRITICAL COMPONENTS ONLY WITH MANUFACTURER'S RECOMMENDED PARTS.

ATTENTION: Δ IL INDIQUE LES COMPOSANTS CRITIQUES DE SÉCURITÉ. POUR MAINTENIR LE DEGRÉ DE SÉCURITÉ DE L'APPAREIL, NE REMPLACER QUE DES PIÈCES RECOMMANDÉES PAR LE FABRICANT.

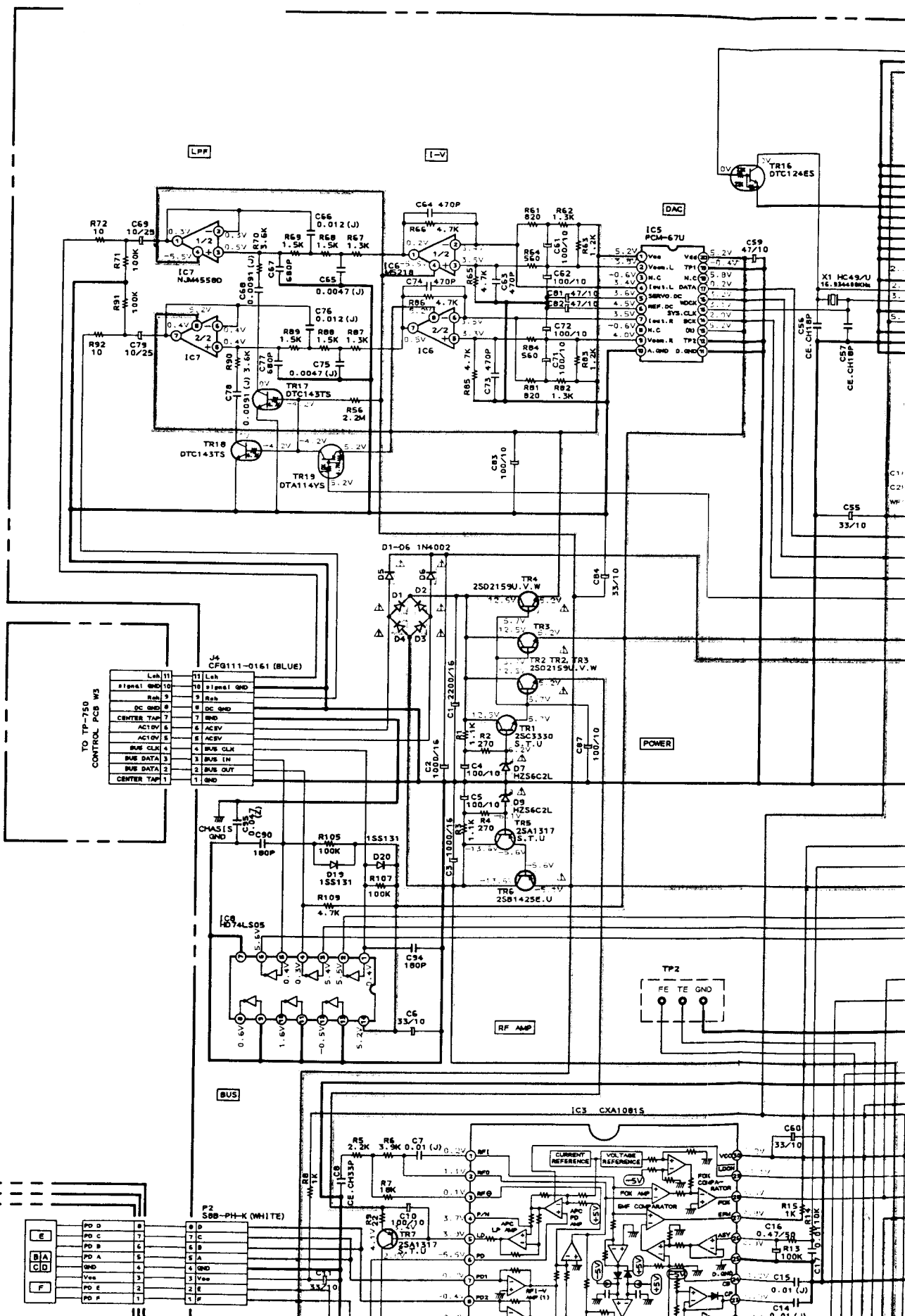

TO TP-750 CONTROL PCB W3

Leh 11	11	Leh	11	signal GND
10	10	signal GND		
9	9	Rch	9	Rch
8	8	DC GND	8	DC GND
7	7	GND	7	GND
6	6	ACBV	6	ACBV
5	5	ACBV	5	ACBV
4	4	BUS CLK	4	BUS CLK
3	3	BUS IN	3	BUS IN
2	2	BUS DATA	2	BUS DATA
1	1	GND	1	GND

P2 SBB-PH-K (WHITE)

E	70 D	8	8 D
BA	70 C	7	7 C
CD	70 B	6	6 B
	70 A	5	5 A
F	Vee	4	4 GND
	70 E	3	3 Vee
	70 F	2	2 E
	70 G	1	1 F

DSP

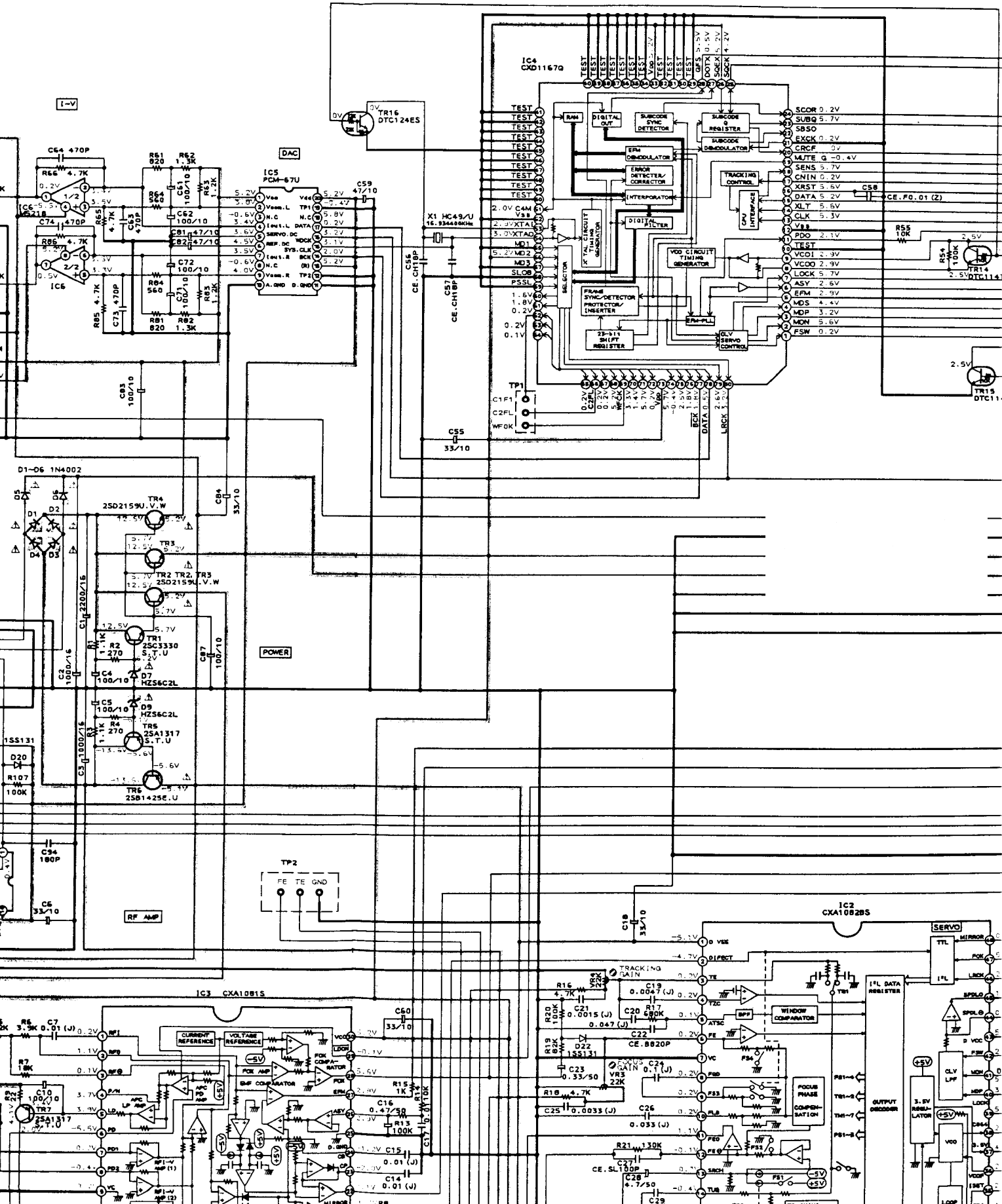



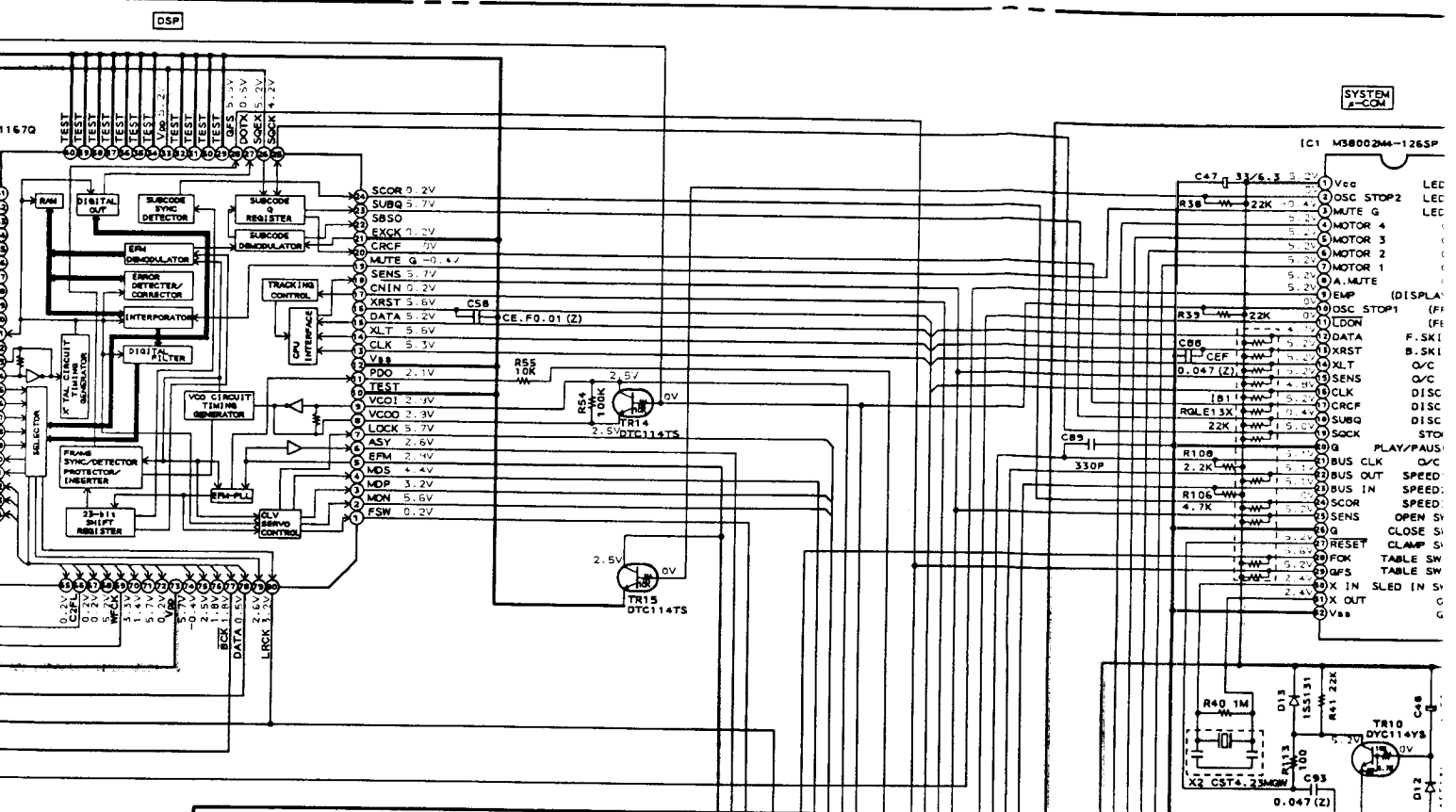

SYSTEM A-COM

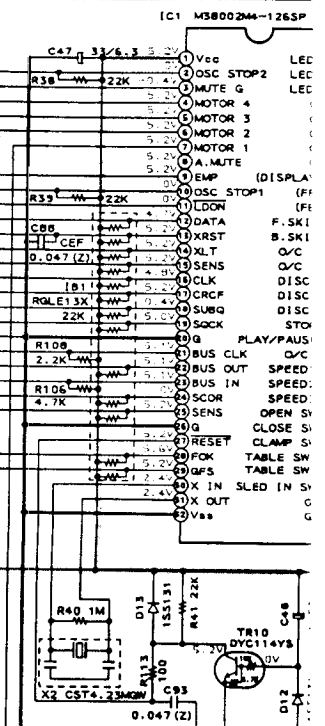

**RTV servis Horvat**  
 Kešinci, 31402 Semeljci  
 031-856-139  
 031-856-637  
 098-788-319  
[rtv-servis-horvat@os.tel.hr](mailto:rtv-servis-horvat@os.tel.hr)  
 Croatia

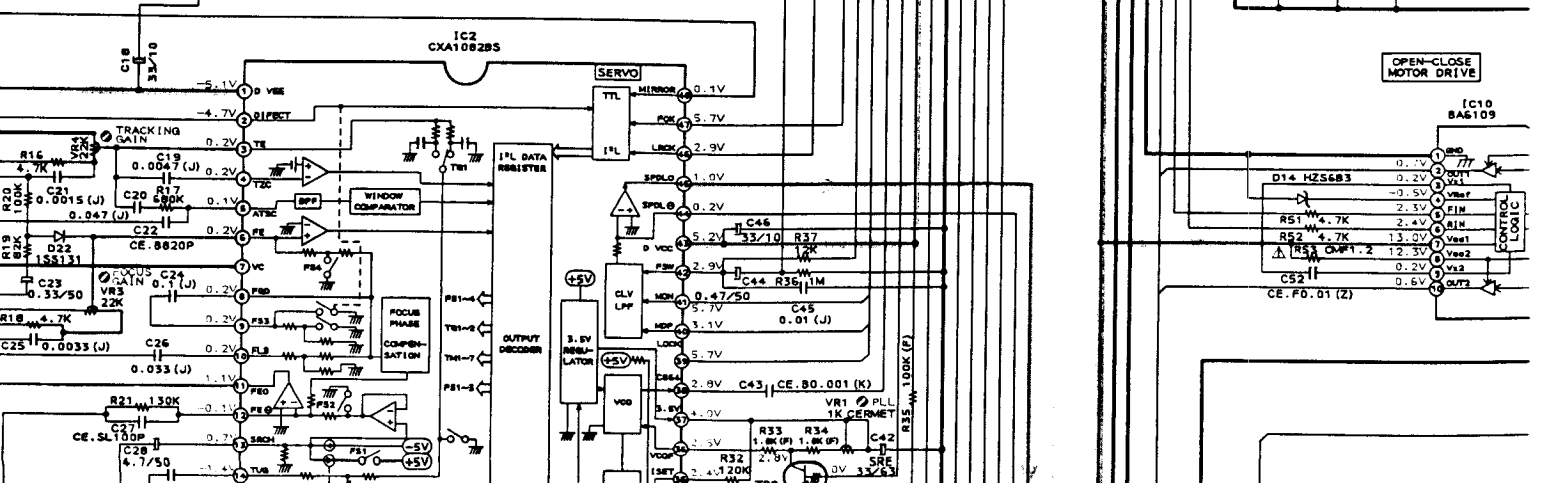
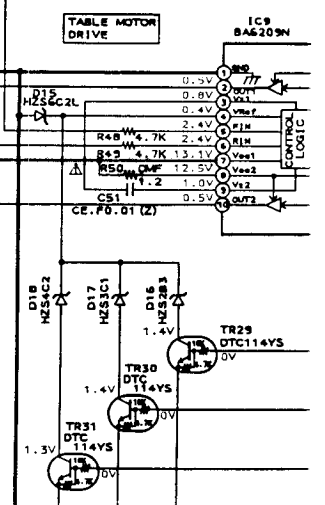



SYSTEM  
2-COM

IC1 M38002M-1265P MKA1C02

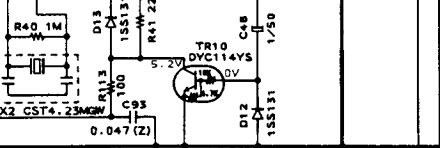
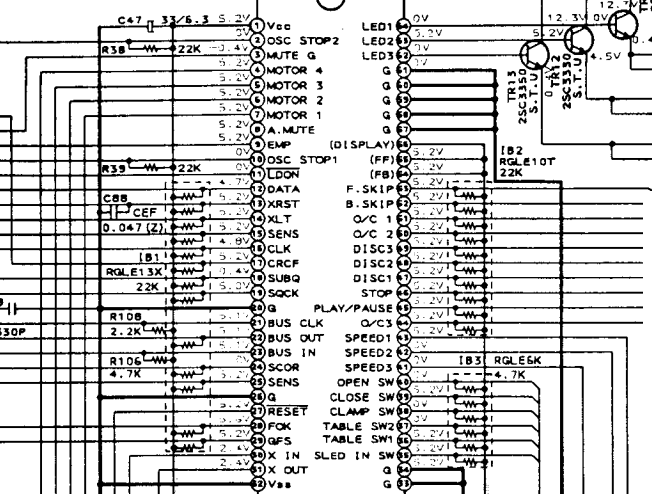
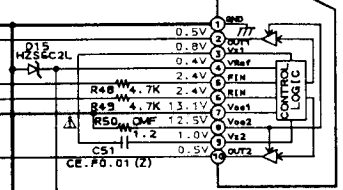

TABLE MOTOR DRIVE

IC9 BA6209N



OPEN-CLOSE MOTOR DRIVE

IC10 BA6109

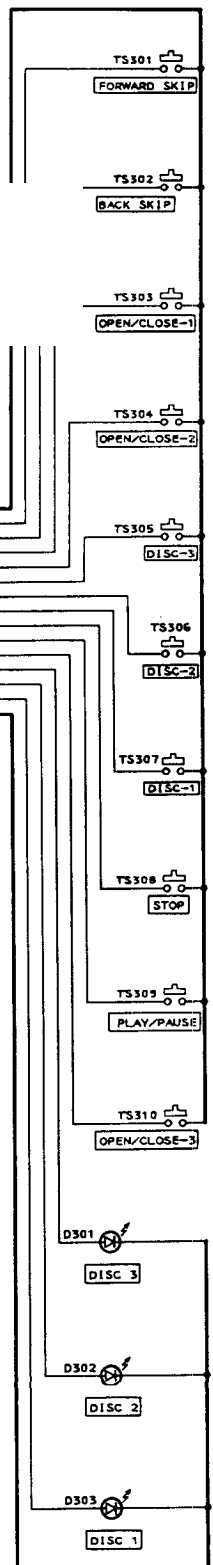
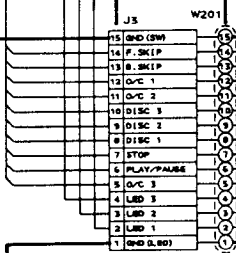
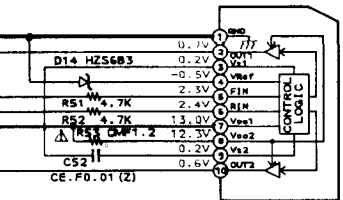

3

4

5

6

7

8

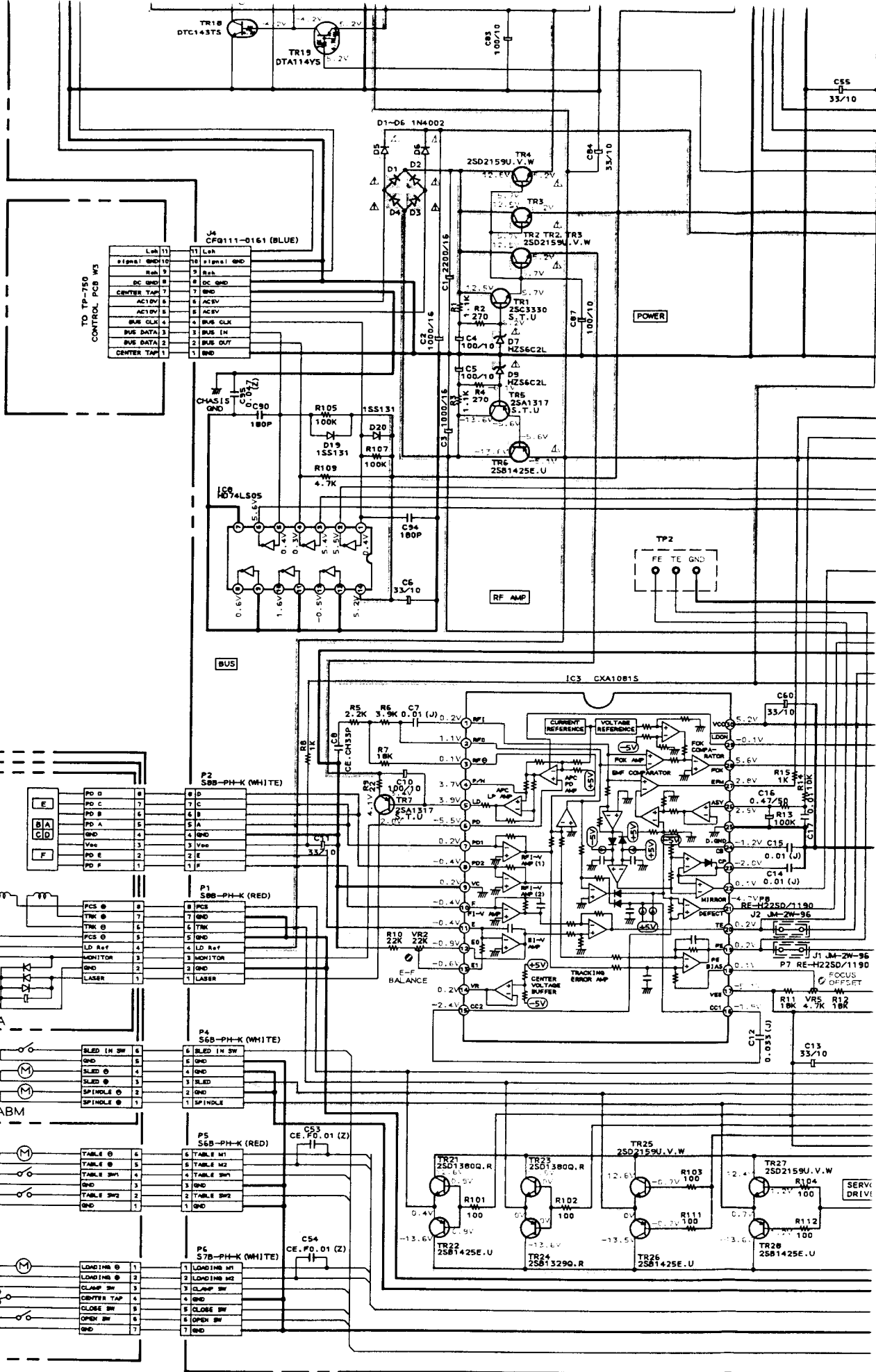

TO TP-750 CONTROL PCB M3

1	1	1	1
2	2	2	2
3	3	3	3
4	4	4	4
5	5	5	5
6	6	6	6
7	7	7	7
8	8	8	8
9	9	9	9
10	10	10	10
11	11	11	11
12	12	12	12
13	13	13	13
14	14	14	14
15	15	15	15
16	16	16	16
17	17	17	17
18	18	18	18
19	19	19	19
20	20	20	20
21	21	21	21
22	22	22	22
23	23	23	23
24	24	24	24
25	25	25	25
26	26	26	26
27	27	27	27
28	28	28	28
29	29	29	29
30	30	30	30
31	31	31	31
32	32	32	32
33	33	33	33
34	34	34	34
35	35	35	35
36	36	36	36
37	37	37	37
38	38	38	38
39	39	39	39
40	40	40	40
41	41	41	41
42	42	42	42
43	43	43	43
44	44	44	44
45	45	45	45
46	46	46	46
47	47	47	47
48	48	48	48
49	49	49	49
50	50	50	50
51	51	51	51
52	52	52	52
53	53	53	53
54	54	54	54
55	55	55	55
56	56	56	56
57	57	57	57
58	58	58	58
59	59	59	59
60	60	60	60
61	61	61	61
62	62	62	62
63	63	63	63
64	64	64	64
65	65	65	65
66	66	66	66
67	67	67	67
68	68	68	68
69	69	69	69
70	70	70	70
71	71	71	71
72	72	72	72
73	73	73	73
74	74	74	74
75	75	75	75
76	76	76	76
77	77	77	77
78	78	78	78
79	79	79	79
80	80	80	80
81	81	81	81
82	82	82	82
83	83	83	83
84	84	84	84
85	85	85	85
86	86	86	86
87	87	87	87
88	88	88	88
89	89	89	89
90	90	90	90
91	91	91	91
92	92	92	92
93	93	93	93
94	94	94	94
95	95	95	95
96	96	96	96
97	97	97	97
98	98	98	98
99	99	99	99
100	100	100	100

KSS-210A

KSM-2101 ABM

YMC-02

POWER

RF AMP

BUS

IC3 CXA10B15

SERVO DRIVE

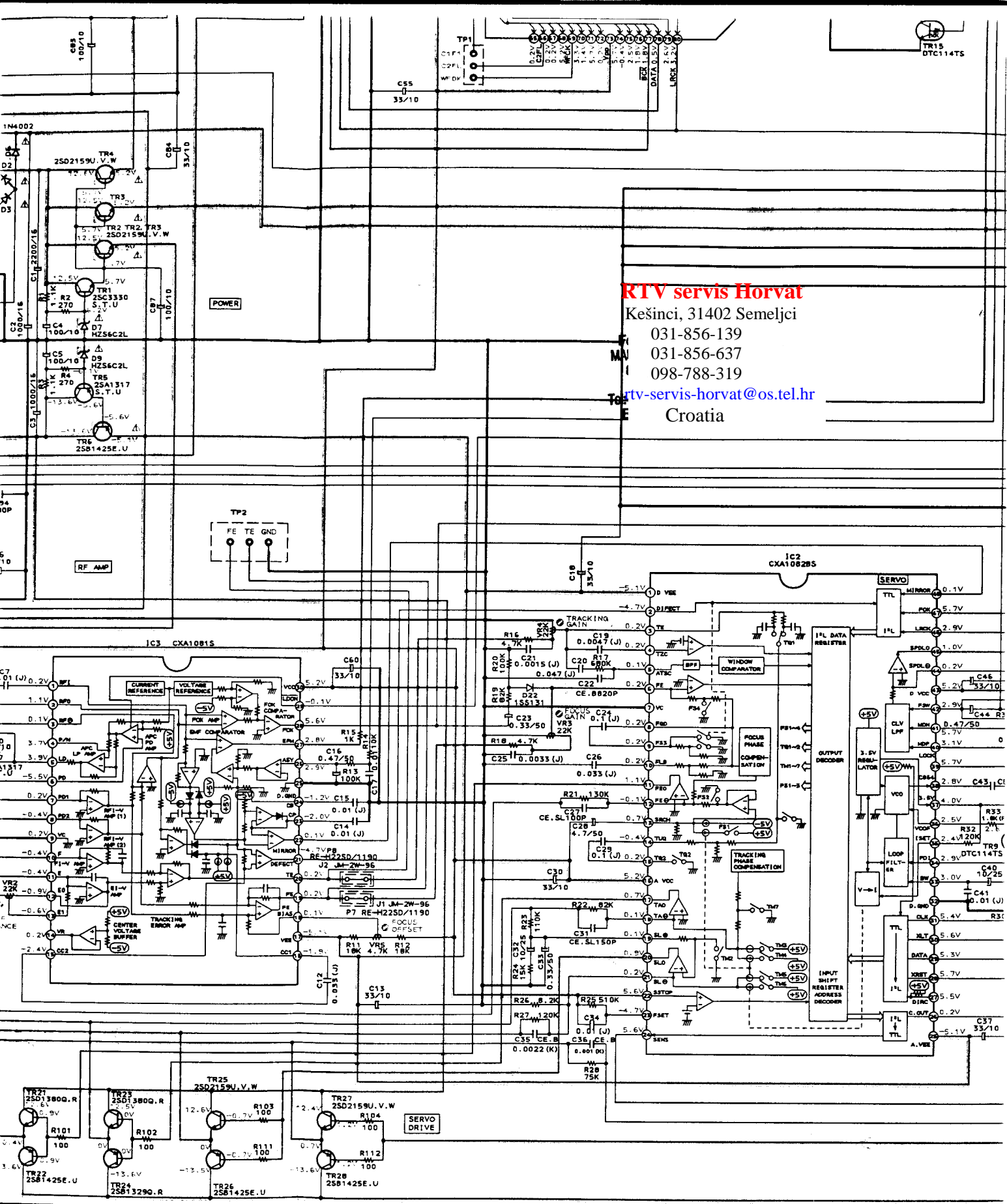

**RTV servis Horvat**

Kešinci, 31402 Semeljci  
 031-856-139  
 031-856-637  
 098-788-319

rtv-servis-horvat@os.tel.hr  
 Croatia

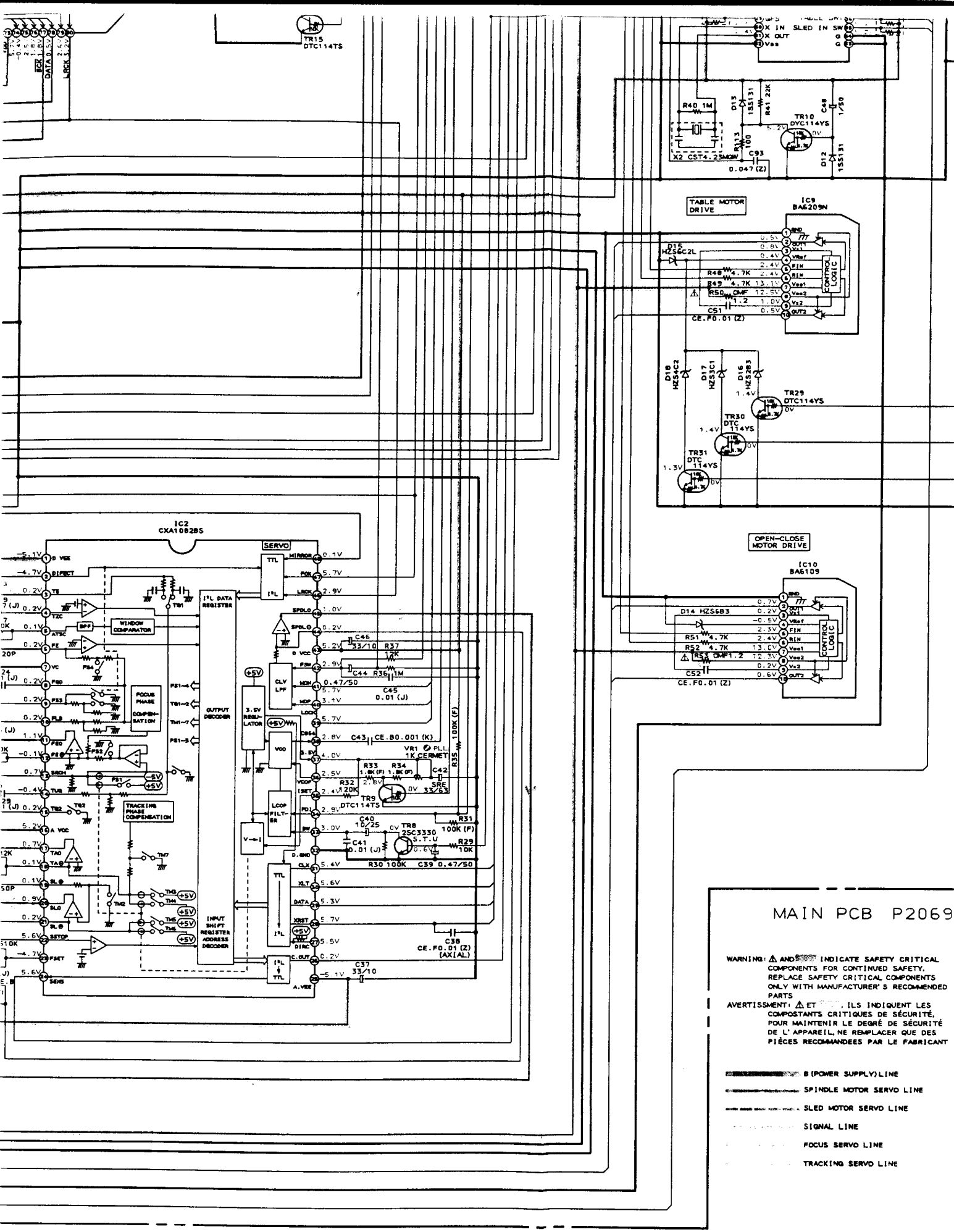

### MAIN PCB P2069

WARNING:  $\triangle$  AND  $\square$  INDICATE SAFETY CRITICAL COMPONENTS FOR CONTINUED SAFETY. REPLACE SAFETY CRITICAL COMPONENTS ONLY WITH MANUFACTURER'S RECOMMENDED PARTS

AVERTISSEMENT:  $\triangle$  ET  $\square$  ILS INDIQUENT LES COMPOSANTS CRITIQUES DE SÉCURITÉ. POUR MAINTENIR LE DEGRÉ DE SÉCURITÉ DE L'APPAREIL, NE REMPLACER QUE DES PIÈCES RECOMMANDÉES PAR LE FABRICANT

- $\text{--- B ---}$  B (POWER SUPPLY) LINE
- $\text{--- S ---}$  SPINDLE MOTOR SERVO LINE
- $\text{--- SL ---}$  SLED MOTOR SERVO LINE
- $\text{--- SGL ---}$  SIGNAL LINE
- $\text{--- FS ---}$  FOCUS SERVO LINE
- $\text{--- TS ---}$  TRACKING SERVO LINE

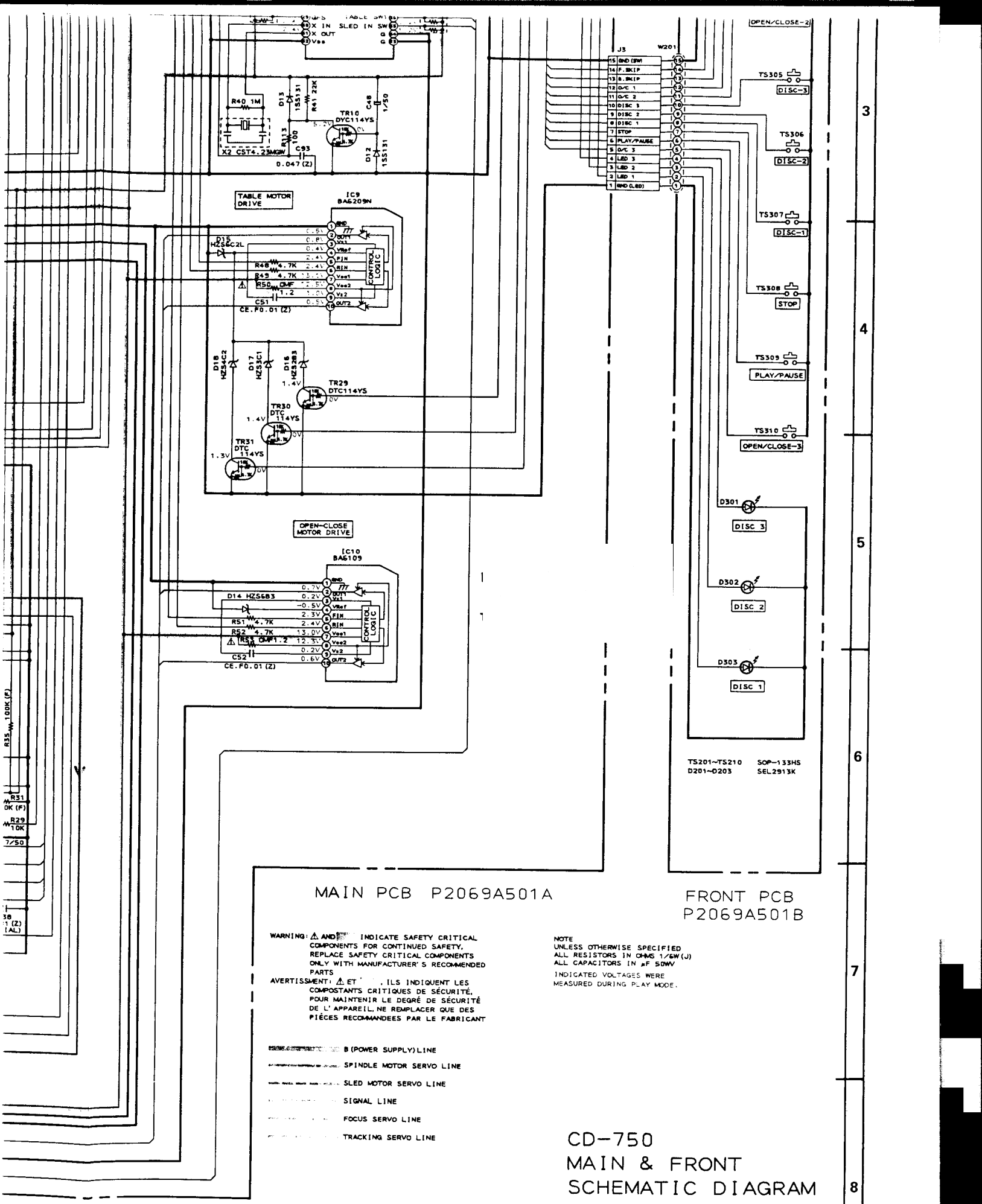

MAIN PCB P2069A501A

FRONT PCB P2069A501B

WARNING:  $\Delta$  AND  $\Delta$  INDICATE SAFETY CRITICAL COMPONENTS FOR CONTINUED SAFETY. REPLACE SAFETY CRITICAL COMPONENTS ONLY WITH MANUFACTURER'S RECOMMENDED PARTS

AVERTISSEMENT:  $\Delta$  ET  $\Delta$  ILS INDIQUENT LES COMPOSANTS CRITIQUES DE SÉCURITÉ. POUR MAINTENIR LE DEGRÉ DE SÉCURITÉ DE L'APPAREIL, NE REMPLACER QUE DES PIÈCES RECOMMANDÉES PAR LE FABRICANT

NOTE  
UNLESS OTHERWISE SPECIFIED  
ALL RESISTORS IN OHMS 1/6W (J)  
ALL CAPACITORS IN  $\mu$ F 50WV  
INDICATED VOLTAGES WERE  
MEASURED DURING PLAY MODE.

- B (POWER SUPPLY) LINE
- SPINDLE MOTOR SERVO LINE
- SLED MOTOR SERVO LINE
- SIGNAL LINE
- FOCUS SERVO LINE
- TRACKING SERVO LINE

CD-750  
MAIN & FRONT  
SCHEMATIC DIAGRAM  
No. 8-8 P206901M  
A01

3  
4  
5  
6  
7  
8

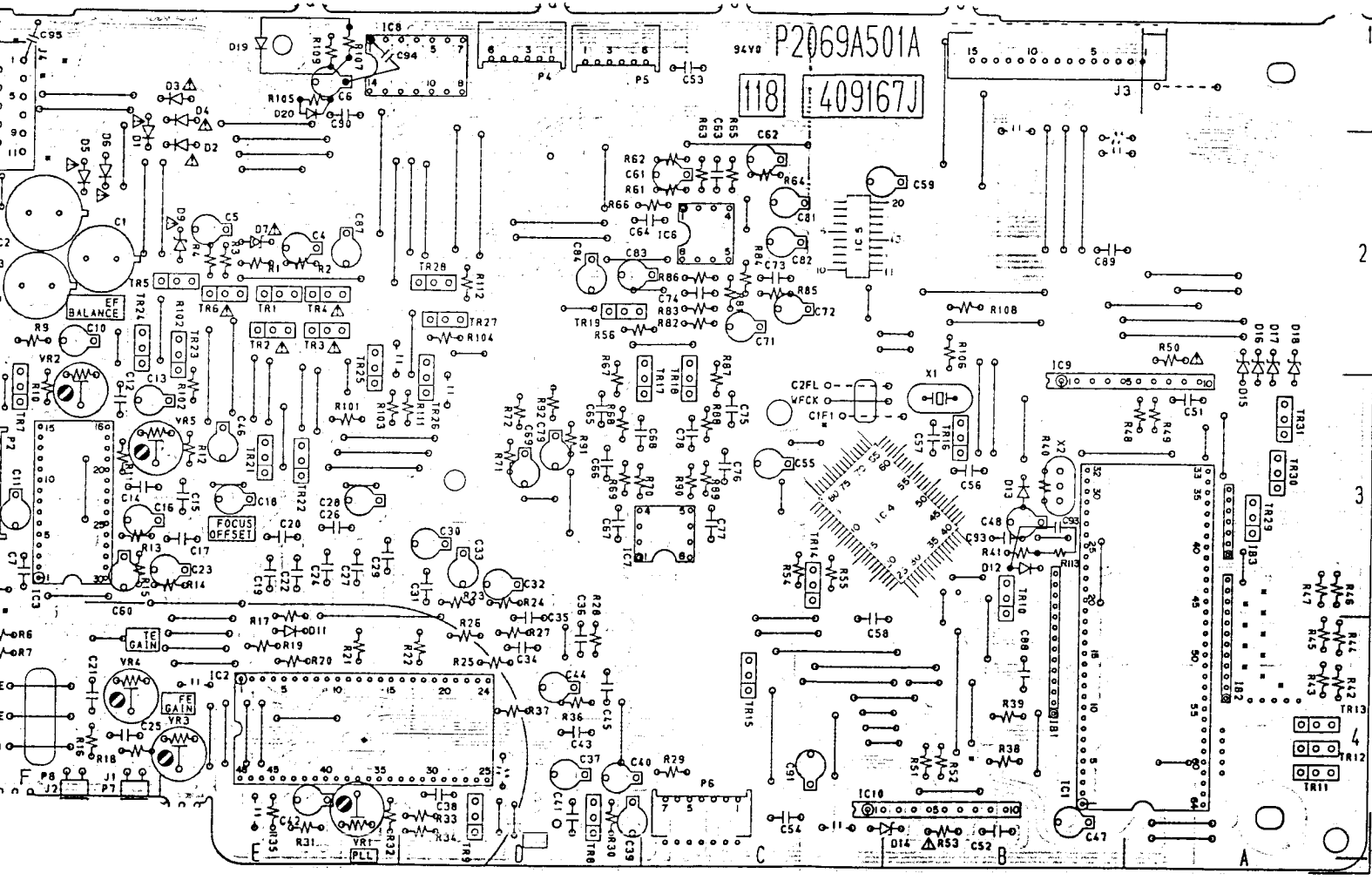
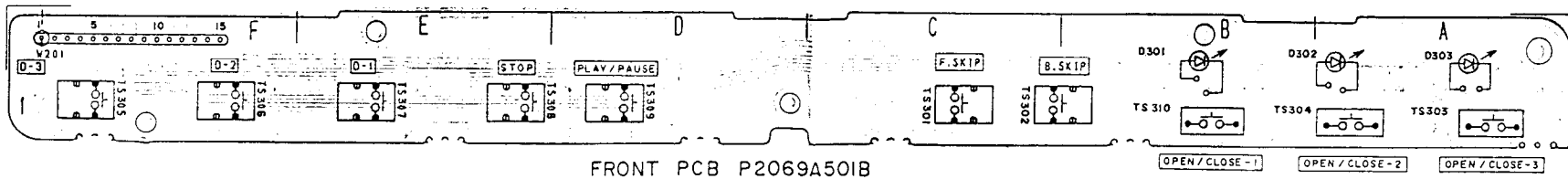

PRINCIPAL PARTS LOCATION

- ICs  
 IC1 ..... 3,4A,B  
 IC2 ..... 4D,E  
 IC3 ..... 3F  
 IC4 ..... 3B,C  
 IC5 ..... 2C  
 IC6 ..... 2C  
 IC7 ..... 3C,D  
 IC8 ..... 1D,E  
 IC9 ..... 3A,B  
 IC10 ..... 4B,C

CONNECTORS

- P1 ..... 2,3F  
 P2 ..... 3F  
 P4 ..... 1D  
 P5 ..... 1D  
 P6 ..... 4C  
 P7 ..... 4F  
 P8 ..... 4F

TRANSISTORS

- TR1 ..... 2E  
 TR2 ..... 2E  
 TR3 ..... 2E  
 TR4 ..... 2E  
 TR5 ..... 2E  
 TR6 ..... 2E  
 TR7 ..... 3F  
 TR8 ..... 4D  
 TR9 ..... 4D  
 TR10 ..... 3B  
 TR11 ..... 4A  
 TR12 ..... 4A  
 TR13 ..... 4A  
 TR14 ..... 3C  
 TR15 ..... 4C  
 TR16 ..... 3B  
 TR17 ..... 3D  
 TR18 ..... 3C  
 TR19 ..... 2D  
 TR21 ..... 3E  
 TR22 ..... 3E  
 TR23 ..... 2,3E  
 TR24 ..... 2F  
 TR25 ..... 2,3E  
 TR26 ..... 3D  
 TR27 ..... 2D  
 TR28 ..... 2D  
 TR29 ..... 3A  
 TR30 ..... 3A  
 TR31 ..... 3A

INDICATES SAFETY CRITICAL COMPONENTS FOR CONTINUED SAFETY.  
 REPLACE SAFETY CRITICAL COMPONENTS ONLY WITH MANUFACTURER'S  
 RECOMMENDED PARTS

INDIQUE LES COMPOSANTS CRITIQUES DE SÉCURITÉ.  
 POUR MAINTENIR LE DEGRÉ DE SÉCURITÉ DE L'APPAREIL,  
 NE REMPLACER QUE DES PIÈCES RECOMMANDÉES PAR LE FABRICANT

M38002M4-126SP MXA1CD2 (CD-750 SYSTEM CONTROL MI-COM)

Pin No.	PORT NAME	I/O	DESCRIPTION
1	VCC		+5V power supply
2	OSC STOP 2	O	Oscillator control output for main CLOCK, VCO and PLL.
3	MUTE G	O	Output to stop audio data H:mute on
4	MOTOR 4	O	TRAY control output
5	MOTOR 3	O	TRAY control output
6	MOTOR 2	O	TRAY rotation control output
7	MOTOR 1	O	TRAY rotation control output
8	AUDIO MUTE	O	Not used
9	EMP	O	Emphasis control output
10	OSC STOP 1	O	Oscillator control output for main CLOCK, VCO and PLL.
11	LDON	O	Laser diode ON/OFF control output H:laser off
12	DATA	O	Command data output
13	XRST	O	Reset signal output
14	XLT	O	Latch signal output
15	SENS	I	Auto sequence end detection input
16	CLK	O	Clock signal output
17	CRCF	I	Input to detect Sub Code - Q CRC check
18	SUBQ	I	Input to detect Sub Code - Q data
19	SQCK	O	Reading clock out of Sub Code Q data
20	GND		GND
21	CD CLK IN	I	Bus clock from TUNER input
22	BUS OUT	O	Bus data output to TUNER
23	CD DATA IN	I	Bus data input from TUNER
24	SCOR	I	Sub code - Q data detect input
25	SENS	I	Auto sequence end detection input
26	GND		GND
27	RESET	I	Reset input
28	FOK	I	Focus lock detection input H:Focus lock
29	GFS	I	Input to detect PLL lock condition H:lock on
30	X IN	I	Main clock input
31	X OUT	O	Main clock output
32	VSS		GND
33	GND		GND
34	GND		GND
35	IN SW	I	Input to detect pick up position
36	LU SW 1	I	Input to detect disc rotation position
37	LU SW 2	I	Input to detect disc rotation position
38	CLAMP SW	I	Input to detect disc clamp position
39	CLOSE SW	I	Input to detect tray close position
40	OPEN SW	I	Input to detect tray open position
41	SPEED 3	O	TRAY rotation control output
42	SPEED 2	O	TRAY rotation control output
43	SPEED 1	O	TRAY rotation control output
44	OPEN/CLOSE 3	I	Input to open or close and rotate TRAY
45	PLAY/PAUSE	I	Input to change mode to PLAY from STOP and PAUSE
46	STOP	I	Input to stop every movement and return PICK UP to start position
47	DISC 1	I	Input to play DISK 1
48	DISC 2	I	Input to play DISK 2
49	DISC 3	I	Input to play DISK 3
50	OPEN/CLOSE 2	I	Input to open or close and rotate TRAY
51	OPEN/CLOSE 1	I	Input to open or close and rotate TRAY
52	BS	I	To skip to next tune
53	FS	I	To skip to next tune
54	FB	I	Input for backward quick movement
55	FF	I	Input for forward quick movement
56	DISPLAY	I	Display control input
57	GND		GND
58	GND		GND
59	GND		GND
60	GND		GND
61	GND		GND
62	LED 3	O	LED control output
63	LED 2	O	LED control output
64	LED 1	O	LED control output

LC7800 (Input Port Expander)

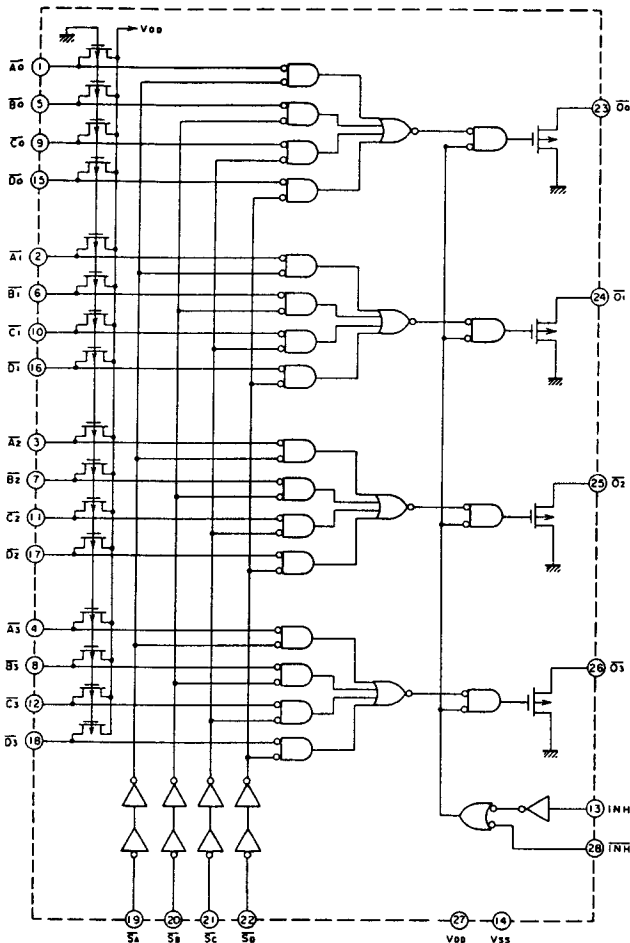

PORT NAME	I/O	DISRIPTION
SW C	O	Output switch C
OUT SA	O	Output switch A
OUT SB	O	Output switch B
OUT SC	O	Output switch C
MIX LEVEL	O	Control TR25 and decrease 2dB main signal GEQ level
BUS CLK	I	Bus clock input
BUS D.OUT	O	Bus data output
BUS D.IN	I	Bus data input
VP SW	-	Not used
P. MUTE	O	Mute operation and control TR24 L: ON
MUTE	I	Mute operation and control TR28 H: ON
SDA	O	Out terminal to call and write when EEPROM use
SCL	O	
GEQ A	O	
GEQ B	O	GEQ pre-set frequency response
GEQ C	O	
L.A	O	
L.B	O	Effect level switching
L.C	O	
D.A	O	On delay mode, switch IC12
D.B	O	
RV A	O	Control IC11
RV B	O	
IC LEVEL	O	Output IC3 (M50194P) delay level
DATA	O	Serial data to change IC3 (M50194P) mode
	-	Decide operation mode and set to "H"
RESET	I	Input to reset
	-	Decide operation mode and set to "L"
	-	Not used
X IN	I	Main clock in
X OUT	O	Main clock out
VSS	-	GND
SECK	O	Serial data control IC3 (M50194P) mode
REQ	O	
CLK	O	Serial data control IC204 (LC7522) level
DI	O	
IN SA	I	Input to select L+R/L-R input mode
IN SB	I	
KEY 1	I	Input 10 key matrix
KEY 0	I	
VF ON/OFF	O	On/off filament power supply
P13	O	
P12	O	
P11	O	
P10	O	
P9	O	
P8	O	
P7	O	
P6	O	Output control FLD 27 segments
P5	O	
P4	O	
P3	O	
P2	O	
P1	O	
P14	O	

Pin No.	PORT NAME	I/O	DESCRIPTION
56	P15	O	
57	P16	O	
58	P17	O	
59	P18	O	
60	P19	O	
61	P20	O	
62	P21	O	Output control FLD 27 segments
63	P22	O	
64	P23	O	
65	P24	O	
66	P25	O	
67	P26	O	
68	P27	O	
69	D	O	
70	C	O	Output control FLD 12 grids
71	B	O	
72	A	O	
73	VCC	-	+B (+5V)
74	VP	I	VP
75	VSS	-	GND
76	VREF	-	+B (+5V)
77	AD1	I	Input AD 1
78	AD2	I	Input ad 2
79	SW A	O	Output switch A
80	SW B	O	Output switch B



## 145FP MXA1TP3 (TP-750 SYSTEM CONTROL MI-COM)

PORT NAME	I/O	DESCRIPTION
FB 2	O	For switching function output
FA 2	O	For switching function output
VR UP	O	Main VR control (UP) output H:UP
VR DOWN	O	Main VR control (DOWN) output H:DOWN
FB 3	O	SUPER BASS control output
DECK CLK	O	DECK bus clock output
DECK DATA OUT	O	DECK bus data output
DECK DATA IN	I	DECK bus data input
FA 3	O	SUPER BASS control output
CD CLK	O	CD bus clock output
CD DATA OUT	O	CD bus data output
CD DATA IN	I	CD bus data input
G-EQ CLK	O	G-EQ bus clock output
G-EQ DATA OUT	O	G-EQ bus data output
G-EQ DATA IN	I	G-EQ bus data input
FC 1	O	For switching function input
FB 1	O	For switching function input
FA 1	O	For switching function input
FLD OFF	O	FL display off output L:OFF
POWER LED	O	Power led control output
AMP MUTE	O	Pre amp mute control output H:MUTE ON
POWER MUTE	O	Power amp mute control output L:MUTE ON
POWER LED	O	Power LED control output
FM A/M	O	FM auto/mono control output
POWER DOWN	I	Back up dtection input
REMOCON	I	REMOCON signal dtection input
RESET	I	Reset input
XC IN	I	
XC OUT	O	
X IN	I	X'tal OSC
X OUT	O	
VSS		GND
TUNER MUTE	O	Mute control output H:MUTE ON
PLL STRQ	O	PLL control output
PLL STIN	I	PLL control input
PLL CE	O	PLL control output
PLL CLK	O	PLL control output
PLL DATA	O	PLL control output
K 1	I	Key scan input 1
K 0	I	Key scan input 0
SB	O	Super bass led control output
SD	O	Super direct led control output
DIG 9	O	
DIG 8	O	
DIG 7	O	
DIG 6	O	
DIG 5	O	
DIG 4	O	Digit data output
DIG 3	O	
DIG 2	O	
DIG 1	O	
DIG 0	O	
SEG 19	O	
SEG 18	O	
SEG 17	O	Segment data output
SEG 16	O	
SEG 15	O	
SEG 14	O	

Pin No.	PORT NAME	I/O	DESCRIPTION
59	SEG 13	O	
60	SEG 12	O	
61	SEG 11	O	
62	SEG 10	O	
63	SEG 9	O	
64	SEG 8	O	
65	SEG 7	O	Segment data output
66	SEG 6	O	
67	SEG 5	O	
68	SEG 4	O	
69	SEG 3	O	
70	SEG 2	O	
71	SEG 1	O	
72	SEG 0	O	
73	VCC		+5V
74	VEE		-Vp
75	AVSS		GND
76	VREF		+5V
77	TUNED	I	TUNED display input
78	STEREO	I	STEREO display input
79	CD POWER OFF	O	CD power off output H:OFF
80	FC 2	O	For switching function output

μPD75108CW - W20 MXB1DK1 (HX-950 SYSTEM CONTROL MI -CON)

PIN NO.	PORT NAME	I/O	DISCRIPTION
1	O3	I	Input IC702 (LC7800) P13 output pulse
2	O2	I	Input IC702 (LC7800) P12 output pulse
3	O1	I	Input IC702 (LC7800) P11 output pulse
4	O0	I	Input IC702 (LC7800) P10 output pulse
5	REV	I	Command reverse tape play L: ON
6	STOP	I	Command stop mechanism movement L: ON
7	FWD	I	Command forward tape play L: ON
8	REC PAUSE	I	REC PAUSE command input L: ON
9	REEL 2	I	Input detect reel pulse (TAPE II)
10	REEL 1	I	Input detect reel pulse (TAPE I)
11	SD	O	Output decide IC702 (LC7800) input timing
12	SC	O	
13	SB	O	
14	SA	O	
15	BUS DATA IN	I	Bus serial data input
16	BUS DATA OUT	O	Bus serial data output
17	BUS CLK IN	I	Bus clock input
18	AUTO MUTE	I	AUTO MUTE command input L: ON
19	NC	-	Not used
20	TAPE I REC/PB	O	Head recording/playback control output H: playback
21	TAPE II REC/PB	O	
22	PL-COM	O	Plunger ON/OFF control output
23	PL-1	O	
24	PL-2	O	
25	MECHA ON/OFF	O	Stop power supply for mecha.
26	TAPE II PB	O	TAPE II playback switching control output
27	TAPE I PB	O	TAPE I playback switching control output
28	CAP M2 X1/X2	O	Capstan motor X1/X2 speed switching output L: 1 H: 2
29	CAP M1 X1/X2	O	
30	X1 PB 70μS	O	X1/X2 speed playback EQ switching output
31	VCC	-	+5V
32	VDD	-	+5V
33	REC MUTE 1	O	REC MUTE control output L: ON
34	X2 REC PEAK	O	X1/X2 speed recording peaking frequency switching output
35	X1 REC PEAK	O	
36	OSC 2	O	Bias OSC control output H: ON
37	REC MET 2	O	Metal tape recording EQ output
38	REC CrO2 2	O	CrO2 tape recording EQ output
39	OSC 1	O	Bias OSC control output H: ON
40	FADE	O	Fade edit control output
41	REC MET 1	O	Metal tape recording EQ output
42	REC CrO2 1	O	CrO2 tape recording EQ output
43	X2 PB PEAK	O	X1/X2 PB peaking frequency output
44	X2 PB 70μS	O	X2 speed playback EQ switching output
45	RESET	I	Reset signal input
46	X2	O	Main clock output
47	X1	I	Main clock input
48	REC MUTE 2	O	Rec mute control output L: ON
49	BOP	I	Music interval detection signal input
50	TAPE II	I	Input TAPE II operation key L: ON
51	TAPE I	I	Input TAPE I operation key L: ON
52	FF	I	Command fast forward tape play L: ON
53	REW	I	Command rewind tape play L: ON
54	X2 DUB	I	Input X2 dubbing operation
55	X1 DUB	I	Input X1 dubbing operation
56	DOLBY REC/PB	O	Dolby IC recording/playback
57	CKS	O	LED control output
58	CKL	O	
59	A	O	
60	TAPE I LAMP	O	TAPE I lamp control output
61	TAPE II LAMP	O	TAPE II lamp control output
62	CROSS	O	Cross edit control output
63	PB MUTE	O	Playback mute control output
64	VSS	-	GND

μPD75108CW - W03 MXA1DK1 (HX-750 SYSTEM CONTROL MI-COM)

Pin No.	PORT NAME	I/O	DESCRIPTION
1	PLAY-II	O	Input detect head position
2	PACK-II	O	Input detect pack
3	AR-REV-II	O	Input inhibit reverse recording
4	120μ/70μ-II	O	Input detect 120μs/70μs tape L:120μs
5	AR-FWD-II	O	Input inhibit forward recording
6	PLAY I	O	Input detect head position
7	PACK I	O	Input detect pack
8	120μ/70μ-I	O	Input detect 120μs/70μs tape L:120μs
9	REEL-II	O	Reel pulse input
10	REEL-I	O	Reel pulse input
11	x 1 PB 70μs	O	x 1/ x 2 speed playback EQ switching output
12	x 2 PB 70μs	O	x 2 speed playback EQ switching output
13	PB MUTE	O	Playback mute control output
14	CROSS	O	CROSS EDIT control output
15	DATA IN	I	Bus serial data input
16	DATA OUT	O	Bus serial data output
17	CLK IN	I	Bus clock input
18	BOP	I	Music interval detection signal input H:Music interval
19	PB TAPE I	O	TAPE I playback switching control output
20	PB TAPE II	O	TAPE II playback switching control output
21	HEAD REC/PB	O	HEAD recording/playback control output H:playback
22	MECHA POWER	O	Capstan motor stop input
23	MOTOR x 1/ x 2-I	O	Capstan motor x 1/ x 2 speed switching output L: x 1 H: x 2
24	PL COMMON	O	Plunger ON/OFF control output
25	PL-I	O	Plunger ON/OFF control output
26	x 2 PB PEAK	O	For x 1/ x 2 speed playback peaking frequency switching
27	MOTOR x 1/ x 2-II	O	Capstan motor x 1/ x 2 speed switching output L: x 1 H: x 2
28	PL-II	O	Plunger ON/OFF control output
29	FWD LAMP-II	O	TAPE II ► LAMP control output
30	FWD LAMP-I	O	TAPE I ► LAMP control output
31	VCC		+5V power supply
32	VDD		+5V power supply
33	x 1 DUBBING LAMP	O	x 1 DUBBING LAMP control output
34	REV LAMP-I	O	TAPE I ◄ LAMP control output
35	REC PAUSE LAMP	O	REC PAUSE LAMP control output
36	x 2 DUBBING LAMP	O	x 2 DUBBING LAMP control output
37	REV LAMP-II	O	TAPE II ◄ LAMP control output
38	TAPE II LAMP	O	TAPE II LAMP control output
39	TAPE I LAMP	O	TAPE I LAMP control output
40	MAIN VR LAMP	O	MAIN VR LAMP control output
41	TAPE II	I	TAPE II operation input L:ON
42	TAPE I	I	TAPE I operation input L:ON
43	x 1 DUB	I	x 1 SPEED DUBBING L:ON
44	x 2 DUB	I	x 2 SPEED DUBBING L:ON
45	RESET	I	Reset signal input
46	x 2	O	Main clock output
47	x 1	I	Main clock input
48	REW	I	Command rewind tape play L:ON
49	REV	I	Command reverse tape play L:ON
50	STOP	I	Command stop mechanism movement L:ON
51	FWD	I	Command forward tape play L:ON
52	FF	I	Command fast forward tape play L:ON
53	REC PAUSE	I	REC PAUSE command input L:ON
54	AUTO MUTE	I	AUTO MUTE command input L:ON
55	POWER SW	I	Power switch ON/OFF command input
56	PACK MUTE	O	PACK MUTE control output
57	DOLBY REC/PB	O	DOLBY recording/playback control output
58	REC MUTE	O	REC MUTE control output L:MUTE ON
59	x 2 REC PEAKING	O	For x1/ x 2 speed recording peaking frequency switching
60	REC CrO <sub>2</sub>	O	CrO <sub>2</sub> tape recording EQ switching output H:CrO <sub>2</sub> tape
61	FADE	O	FADE EDIT control output
62	OSC	O	Bias OSC control output H:OSC ON
63	x1 REC PEAKING	O	For x1/ x 2 speed recording peaking frequency switching H: x1
64	VSS		GND

**RTV servis Horvat**

Kešinci, 31402 Semeljci

031-856-139

031-856-637

098-788-319

[rtv-servis-horvat@os.tel.hr](mailto:rtv-servis-horvat@os.tel.hr)

Croatia