

SERVICE MANUAL

AKAI TAPE RECORDER

MODEL

X-355

ALSO APPLICABLE FOR MODEL X-355D

TABLE OF CONTENTS

I	SPECIFICATIONS	1
II	MEASURING METHOD	2
III	CONTROL LOCATION.....	4
IV	PROCEDURE FOR REMOVAL	5
V	TRANSPORT MECHANISM.....	7
VI	MECHANISM ADJUSTMENT	15
VII	AMPLIFIER ADJUSTMENT.....	18
VIII	MAINTENANCE.....	20
IX	REPLACEMENT PARTS TABLE.....	22
X	EXPLODED VIEW OF COMPONENT PARTS	27
XI	TRUBLE SHOOTING CHART	
	(AMPLIFIER SECTION) PLAYBACK TROUBLE.....	31
	(AMPLIFIER SECTION) RECORDING TROUBLE	32
	(MECHANICAL SECTION)	33
XII	SCHEMATIC DIAGRAM.....	35
XIII	CONNECTING DIAGRAM	39

I. SPECIFICATION

Style : Portable
Weight : 62.7 lbs. (28.5 kg)
Dimensions : 17- $\frac{3}{8}$ "(H) × 16"(W) × 12- $\frac{1}{8}$ "(D) (440(H) × 407 (W) × 310 (D) m/m overall, case closed.
Power Supply : 100, 110, 117, 120, 125, 130, 140, 200, 210, 217, 220, 225, 230, 240 V.A.C. (Interchangeable)
Recording System: In-line 4 track stereo, monaural recording by using Cross-field bias head.
Tape Speed : 2 speeds: 7- $\frac{1}{2}$ ips (19cm/s), 3- $\frac{3}{4}$ ips. (9.5cm/s) by using adaptor 15 ips (38cm/s) available.
Tape Speed Deviation : Within ±0.5% at 7- $\frac{1}{2}$ ips.
 Within ±1.0% at 3- $\frac{3}{4}$ ips.
Wow and Flutter: Less than 0.08% R.M.S. at 7- $\frac{1}{2}$ ips. (at normal play)
 Less than 0.12% R.M.S. at 7- $\frac{1}{2}$ ips. (at reverse play)
 Less than 0.14% R.M.S. at 3- $\frac{3}{4}$ ips. (at normal play)
 Less than 0.15% R.M.S. at 3- $\frac{3}{4}$ ips. (at reverse play)
Fast Forward and Rewind Time : 45 seconds for either operation using a 1,200 feet recording tape at 50 cycles. 36 seconds at 60 cycles.
Frequency Response : 30 to 24,000 cps ± 3 db at 7- $\frac{1}{2}$ ips.
 30 to 18,000 cps ± 3 db at 3- $\frac{3}{4}$ ips.
Signal to Noise Ratio: Better than 45 db at normal play (7- $\frac{1}{2}$ ips, 3- $\frac{3}{4}$ ips).
 Better than 43 db at reverse play (7- $\frac{1}{2}$ ips, 3- $\frac{3}{4}$ ips).
Distortion (total harmonics) : Within 3% at 1,000 c/s 0 VU (line output)
 Within 5% at 1,000 c/s 0 VU (speaker output at 10 watts (8 Ω))
OUTPUT
Pre-amplifier
 Output : 1,228 V (0 VU) at using 1,000 c/s 0 VU recorded tape. Impedance 1.5 kΩ.
Main Output (speaker output): 20 watts at undistorted power output on each channel. Impedance 8 Ω.
INPUT
Line Input : More than 50 mV. Impedance 100 kΩ.
Microphone
 Input : More than 0.5 mV. Impedance 4 kΩ.
Cross-talk : Less than -80 db (Monaural)
 Less than -45 db (Stereo)
Erase Ratio : Less than -70 db for all tracks.
Insulation
 Resistance : More than 10 MΩ
Insulation
 Durability : 1,000 V.A.C. for more than one minute duration.
Monitor System (in recording) : With record output button at "IN":
 Can be monitored the program being recorded by using

{ built-in speaker
 stereo headphone
 external speakers
 crystal receiver

With playback output button at "IN":

Can be monitored the recorded signals from the playback head by using

{ built-in speaker
 stereo headphone
 external speakers
 crystal receiver

Main Motor : Condenser starting, hysteresis synchronous 2 speeds (4-8 pole) motor.
 Condenser capacity 3 μF (50 c/s)
 2.5 μF (60 c/s)
 More than 1/100 HP
 Power factor 70%
 Revolution 1,500-750 R.P.M. (50 c/s)
 1,800-900 R.P.M. (60 c/s)
Torque Motor : Condenser starting induction motor.
 Condenser capacity 3 μF
 More than 1/100 HP
 Power factor 70%
 Revolution 1,450 R.P.M. (50 c/s)
 1,740 R.P.M. (60 c/s)
Heads
Recording Head: Inline 4 track stereo and monaural.
 Impedance: 135 Ω at 1,000 c/s
 Gap: 4 microns
Playback Head : Inline 4 track stereo and monaural.
 Impedance: 1,000 Ω at 1,000 c/s
 Gap: 2 microns
Erase Head : Inline 4 track stereo.
 Impedance: 750 Ω at 90kc.
 Gap: 0.2 mm
Cross-Field Bias
 Head: Inline 4 track stereo.
 Impedance: 750 Ω at 90kc.
 Gap: 0.2 mm
Record Level Indicator : Vertical indication model "A" VU meter.
Internal Speakers: 6- $\frac{1}{2}$ " round wide range dynamic speaker.
 Impedance: 8 Ω
 Nominal power input: 4W
 Maximum power input: 6W
 Frequency response: 50-10,000 ± 10db.
Transistor Used : 2SB443Ⓐ × 4
 2SB75Ⓔ × 2
 2SB75Ⓑ × 10
 2SB75Ⓐ × 2
 2SB370AⒶ × 2
 2SB338Ⓐ × 4
 2SB370AⒷ × 2 Oscillator
Selenium Used : SPN-01 × 2 Bridged selenium rectifier
 12C-2 × 1 Center top selenium rectifier
Silicone Diode
 Used : SE-05a × 1
 SL-150 × 1
 SW05-a × 1
Reels Used : With adaptor, reels up to 10- $\frac{1}{2}$ " can be used.

II. MEASURING METHOD

TAPE SPEED DEVIATION

1. Method involving use of pre-recorded tape.

Playback on the tape recorder to be tested tape pre-recorded at 1,000 cps $\pm 0.1\%$ for measuring tape speed deviation. Connect the appropriate output to a frequency counter meter in order to measure the tape speed deviation from the resulting deviation of the measured frequency.

2. Method involving use of timing tape (designed for tape speed measurement).

This method utilizes a timing tape marked at intervals of $7\frac{1}{2}$ ". The running time of the tape over 60 marked section is measured in order to calculate the deviation of the tape speed. In application of this method, however, it should be borne in mind that should the timing tape stretch or contract, measurement error is inevitable, so that it is necessary to measure the total length of the tape in advance.

WOW AND FLUTTER

Playback the 3,000 cps pre-recorded tape whose wow and flutter level is guaranteed to be smaller than 0.07% for measurement by means of a wow meter. It is also possible for a 3,000 cps sine wave to be recorded and played for measurement by means of the wow meter. In this case, however, the wow meter indicates a value as much as twice the value given in the specifications on the first page.

FREQUENCY RESPONSE

RECORD :

- 1) Give a sine wave of 1,000 c/s to the Line Input of the recorder to be tested through an attenuator from an audio frequency generator.
- 2) Push the "Record Output Button" and adjust the line input volume so that the VU meter needle indicates "0" VU.
- 3) Under the condition described in (2), lower the input level 16 db by means of the attenuator.
- 4) Connect a microphone to the Microphone Input.
- 5) Start recording. Control the microphone input level and the spot frequency in the range of 30 cps to 25,000 cps from the audio frequency generator and record by talking.

★ Remarks: After announcing the frequency of each point, the microphone volume should immediately be rotated back to minimum.

PLAYBACK :

- 6) Place the "Record Output Button" in the OUT position and push the "Playback Button"
- 7) Set the Equalizer Switch on $7\frac{1}{2}$ " or $3\frac{3}{4}$ " position.
- 8) Set the Tone Switch on "Flat" position.
- 9) Terminate "External Speaker Output" of the recorder with 8Ω resistor and connect a Vacuum Tube Volt Meter (V.T.V.M with milli volts scale).
- 10) Playback the tape previously recorded.
- 11) Adjust the output level to "0" dbm at "1,000 c/s" as indicated on the V.T.V.M. by adjusting the loudness volume.
- 12) Playback the recorded spot frequencies with the conditions in (11); make a memo of output level and plot the value on a graph.

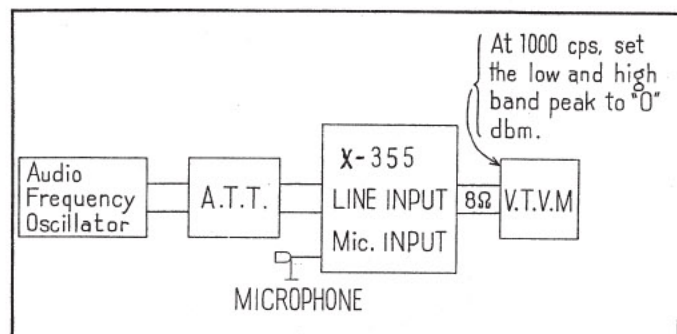

TOTAL HARMONIC DISTORTION FACTOR

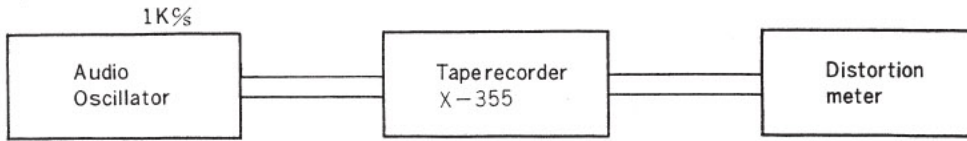

Connect the measuring instrument as shown above, and record the 1,000 cps sine wave at "0" VU. Playback the resultant signal and measure the overall distortion factor. Measure the noise level of the tape recorder with the tape removed; connect the audio oscillator directly to the distortion meter for measurement of the distortion factor of the oscillator.

The required distortion factor may be obtained from the results of the above measurement by the following formula :

$$d_0 = d - d_1 - d_2$$

where,

- d_0 = Required
- d = Overall distortion factor
- d_1 = Noise level
- d_2 = Distortion factor of the oscillator

(Note: New tape of particularly good quality should be used for measurement of the distortion factor).

SIGNAL TO NOISE RATIO

Set the Tone Switch on "Flat" position and playback a tape containing a 1,000 cps sine wave recorded at "0" VU level on a standard recorder. Connect an 8Ω resistor to the output terminals of the recorder and measure its output. Then remove the tape and measure the noise level under the same conditions. Convert into decibels each of the measured values.

POWER OUTPUT

Playback a tape containing a sine wave of 1,000 cps recorded at 0 VU on a standard recorder. Measure the voltage at the output of the recorder to be tested when terminated with 8Ω .

Then use the following formula :

$$P = \frac{E^2}{R}$$

$$\left\{ \begin{array}{l} P = \text{Desired output (W)} \\ E = \text{Measured voltage (R.M.S.)} \\ R = 8 \Omega \end{array} \right.$$

CROSS TALK (Cross talk between the tracks)

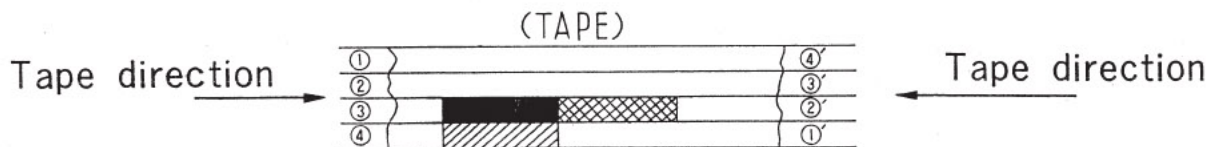

As shown in the figure, first record a 1,000 cps sine wave on track No. 3 at +3 VU level. Next, remove the 1,000 cps input signal and record under a non-input condition.

Then, playback the tape on track No. 3 and No. 1 (reversed condition of tape) through the 1,000 cps B.P.F. (Band Pass Filter, Sensitivity....1:1) and obtain a ratio between the two from the following formula.

$$C = 20 \log \frac{E_0}{E_2 - E_1} (\text{db})$$

$$\left\{ \begin{array}{l} C = \text{Desired cross talk ratio (db)} \\ E_0 = 1,000 \text{ cps signal output level} \\ E_2 = 1,000 \text{ cps cross talk output level} \\ E_1 = \text{No-input signal record level} \end{array} \right.$$

III. CONTROL LOCATION

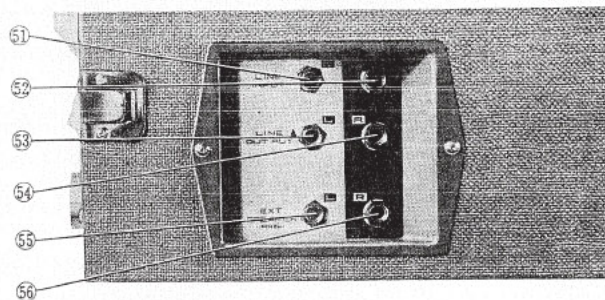
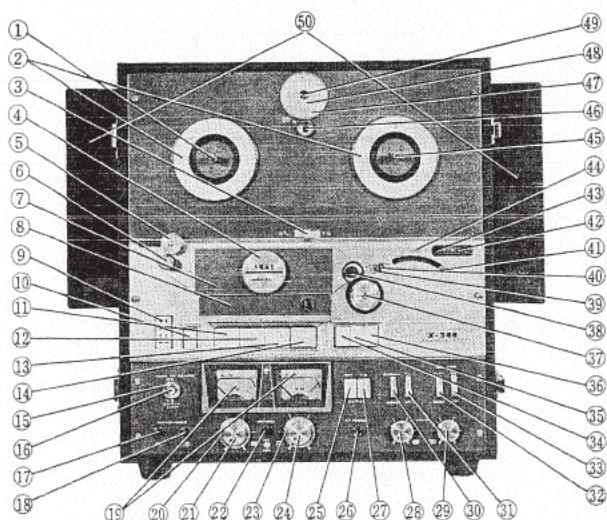

- ① Supply Reel Shaft
- ② Guard Circle
- ③ Speed Change Switch
- ④ Track Selector Knob
- ⑤ Tape Guide
- ⑥ Tape Guide Roller
- ⑦ Head Cover, A
- ⑧ Head Cover, B
- ⑨ Remote Control Socket
- ⑩ Power Button
- ⑪ Stop Button
- ⑫ Rewind Button
- ⑬ Play Button
- ⑭ Fast-Forward Button
- ⑮ Record Safety Lock
- ⑯ Record Safety Button
- ⑰ Microphone Jack (Left)
- ⑱ Microphone Jack (Right)
- ⑲ VU Meter
- ⑳ Line Volume Control (Left)
- ㉑ Microphone Volume Control (Left)
- ㉒ Recording Lamp
- ㉓ Line Volume Control (Right)
- ㉔ Microphone Volume Control (Right)
- ㉕ Record Output Button
- ㉖ Stereo Headphone Jack
- ㉗ Playback Output Button
- ㉘ Volume Control (Left)

- ㉙ Volume Control (Right)
- ㉚ Function Switch
- ㉛ Equalizer Switch
- ㉜ Tone Switch
- ㉝ Speaker ON/OFF Switch
- ㉞ Repeat Button
- ㉟ Reverse Button
- ㊱ Shut-Off Button
- ㊲ Pinch Wheel
- ㊳ Capstan Shaft
- ㊴ Auto. Reverse Pin (I)
- ㊵ Auto. Reverse Pin (II)
- ㊶ Tension Arm
- ㊷ Index Counter
- ㊸ Re-set Button
- ㊹ Tape Holder
- ㊺ Take-up Reel Shaft
- ㊻ Dial Off Button
- ㊼ Auto. Tape Count Meter
- ㊽ Set Dial
- ㊾ Manual Reverse Button
- ㊿ Reflector
- ① Line Input Jack (Left)
- ② Line Input Jack (Right)
- ③ Line Output Jack (Left)
- ④ Line Output Jack (Right)
- ⑤ Ext. Speaker Jack (Left)
- ⑥ Ext. Speaker Jack (Right)

IV. PROCEDURE FOR REMOVAL

- (1) Loosen the RETAINING SCREW of TRACK SELECTOR KNOB by using a Phillips-headed screw driver (3 millimeters in diameter) and remove the TRACK SELECTOR KNOB by hand.
- (2) Loosen the RETAINING SCREWS (marked (a) and (b)) of the HEAD COVER (A) by using the same screw driver and remove the HEAD COVER (A) by hand.
- (3) Loosen the RETAINING SCREWS (marked (a) and (b)) of the HEAD COVER (B) and remove the HEAD COVER (B) in the same manner.

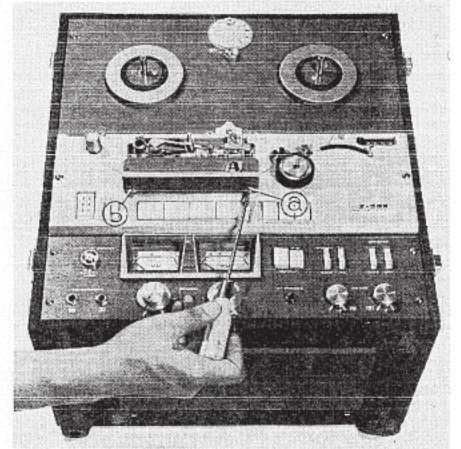
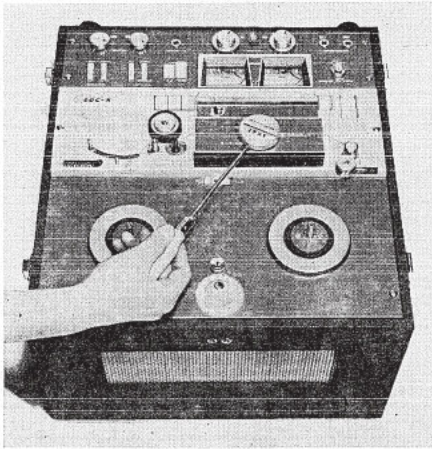

- (4) Loosen the RETAINING SCREW of the TAPE GUIDE by using a larger (4 millimeters in diameter) Phillips-headed screw driver and remove the TAPE GUIDE by hand.
- (5) Loosen the RETAINING SCREW of the PINCH WHEEL by using the same screw driver and remove the PINCH WHEEL by hand.
- (6) Loosen the RETAINING SCREWS (marked (a) and (b)) of the FRONT PANEL by using the same screw driver and remove the FRONT PANEL by hand. In this case, set the SHAFT of the TAPE GUIDE on the left of the FRONT PANEL.

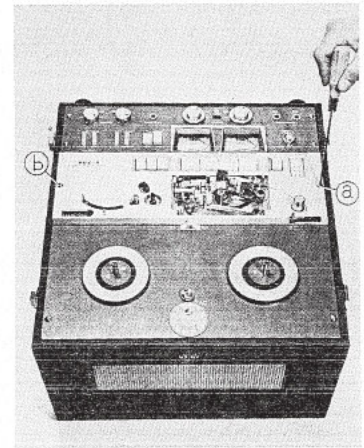
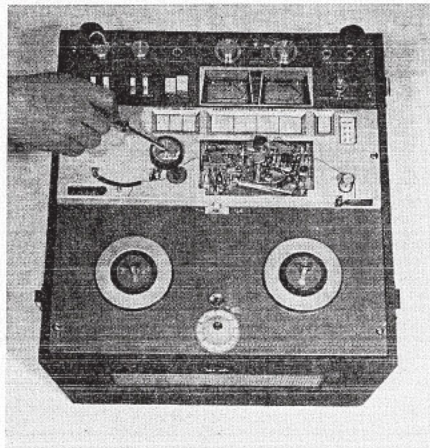
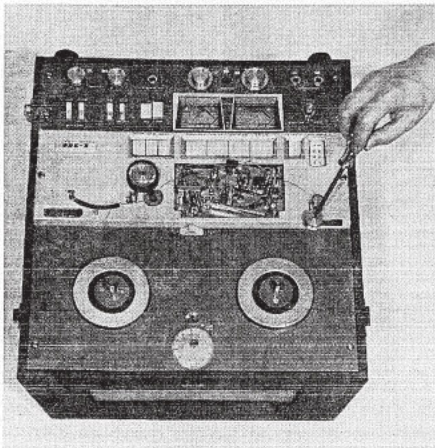

- (7) Loosen the SCREWS (marked from (a) to (h)) by using the same screw driver.
- (8) Loosen the RETAINING SCREWS (marked from (a) to (d)) of the VENTILATOR by using the same screw driver and remove the VENTILATOR by hand.
- (9) Remove the PLUGS (marked (a) to (f)) carefully by hand.

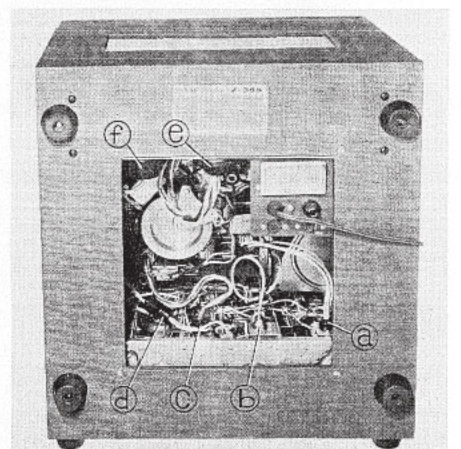
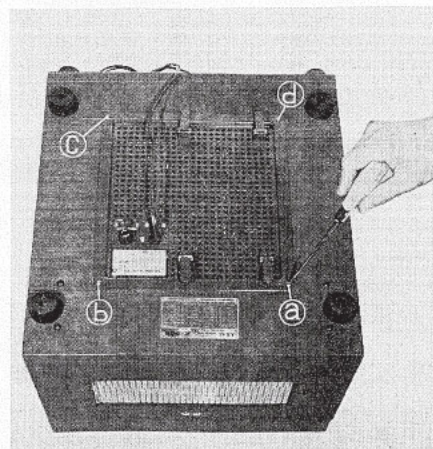
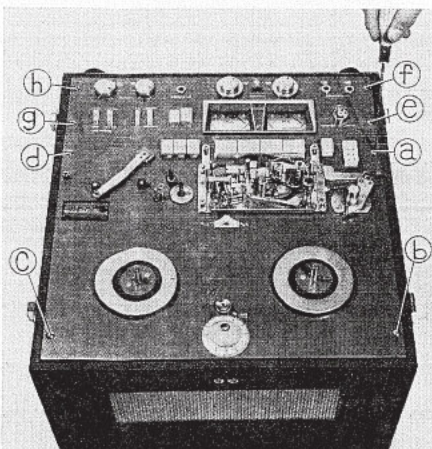

- (10) Remove the TAPE TRANSPORT MECHANISM ASSEMBLY (M) by slowly lifting it from the case as shown in picture.

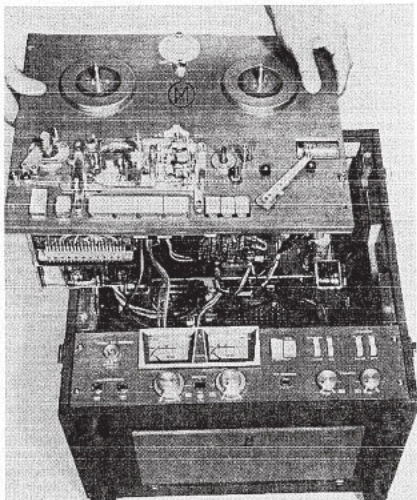

- (11) Loosen the RETAINING SCREWS (marked (a) to (c)) of the AMPLIFIER SHEATHING by using the same screw driver.

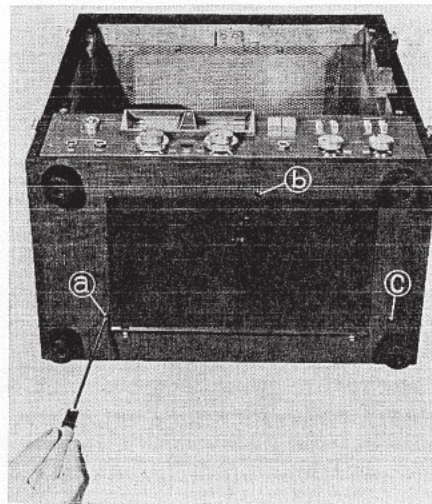

- (12) Disconnect the SPEAKER TIPS (marked (a) to (b)) and remove the AMPLIFIER ASSEMBLY (A) from the case by hand.

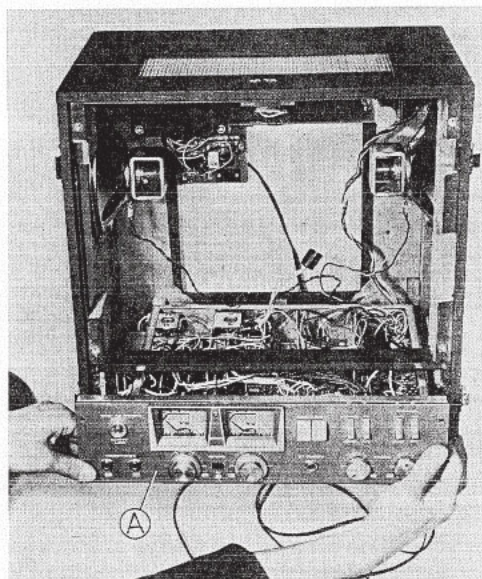

- (13) (14) Loosen the RETAINING SCREWS (marked from (a) to (f)) by using a smaller (3 millimeters in diameter) Phillips-headed screw driver and remove the CARDS of MAIN AMPLIFIER, PLAYBACK, RECORD and RELAY BLOCK by hand.

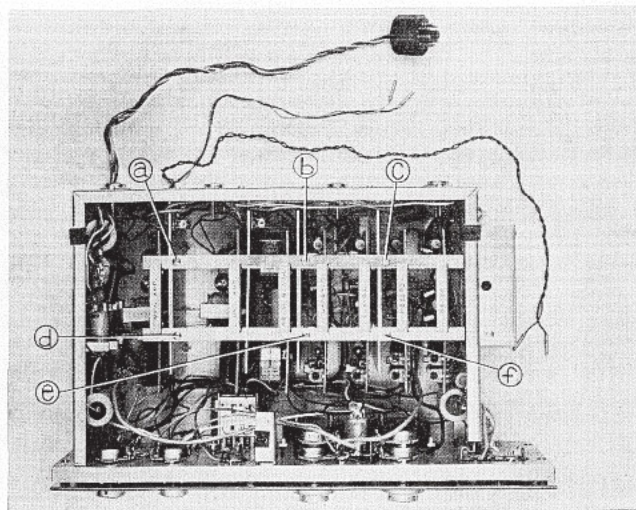
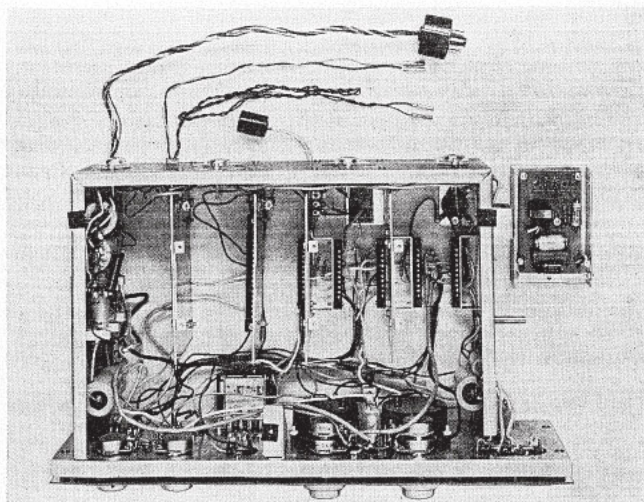

3. FAST FORWARD

Depressing now the fast forward button under the STOP condition causes the relay control current to flow through the micro switch (SW805) as shown by red dotted line in Fig. 4 thereby switching the relay A into ON position. As the relay A is thus locked, the relay control current flows along the red line in Fig. 4 until the relay G and brake solenoid become energized to release the brakes. 120 volts are applied across 8Ω 5W resistor to the fast forward motor as shown in Fig. 5, whereupon the fast forward motion of the tape is effected. This resistor is intended to prevent transient pulse generated when switching the relay contacts.

FIG. 2

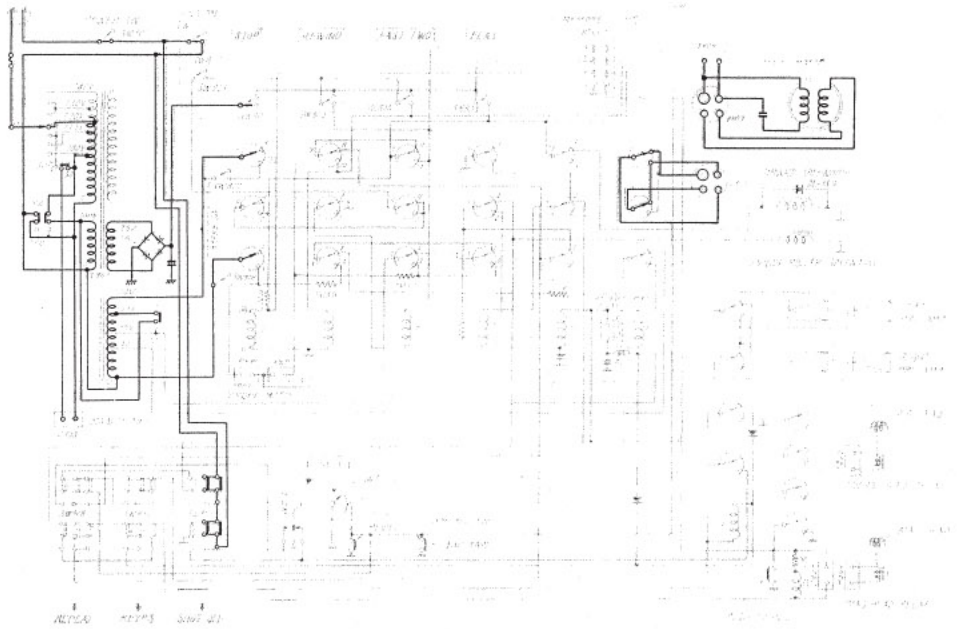

FIG. 3

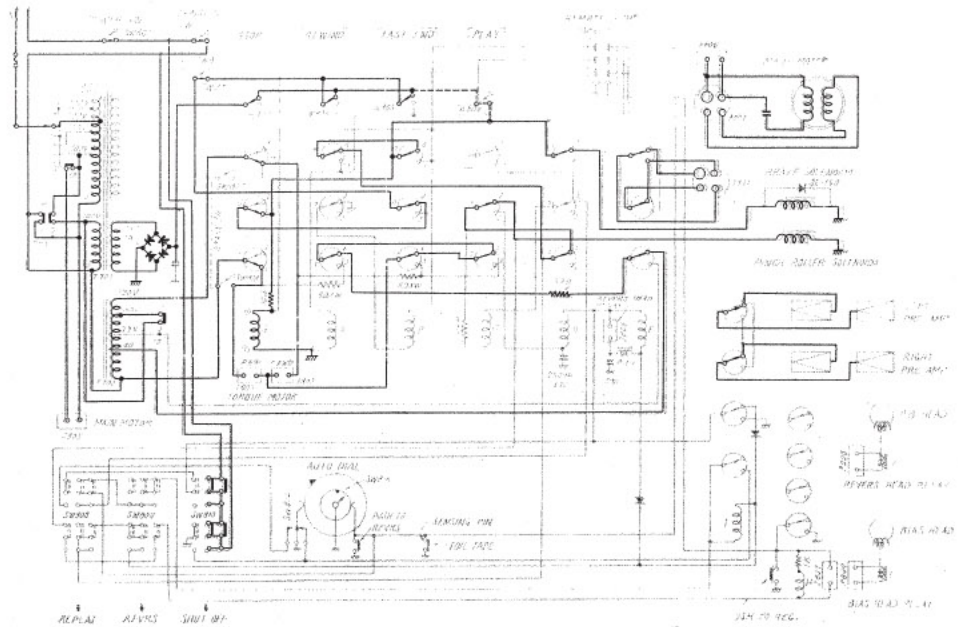

FIG. 4

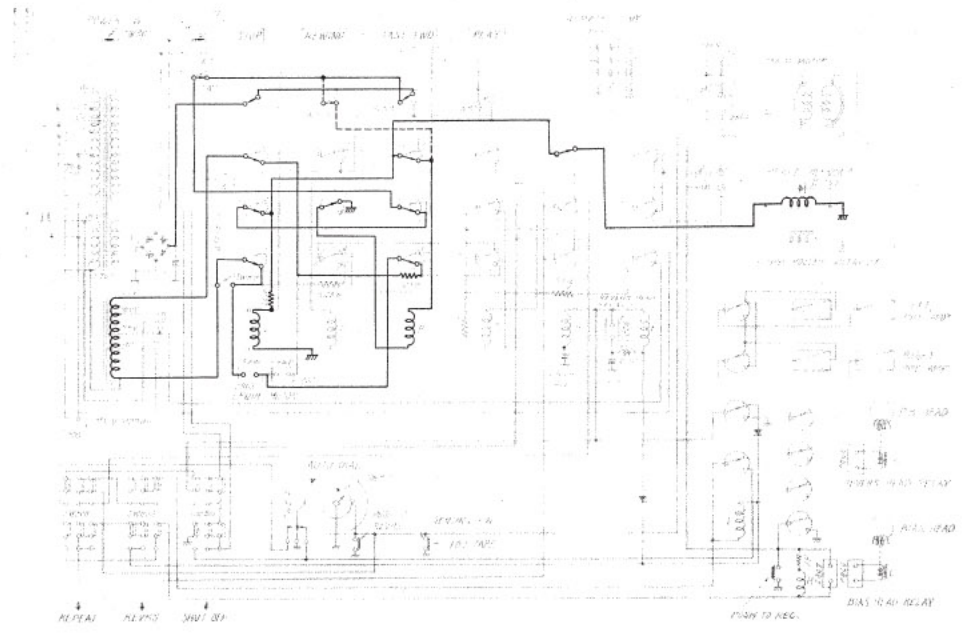
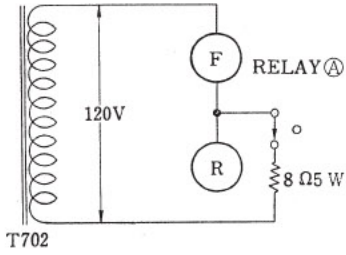

FIG. 5



F : Fast forward motor
 R : Rewind motor

4. REWIND

Depressing the rewind button under the STOP condition causes the current to flow through the micro switch (SW806) as indicated by red dotted line in Fig. 6 so that the relay B is energized and locked by contact 7-10. The relay control current now flows as indicated by red line in Fig. 6 so that the relay G is energized and the brakes released, whereupon the rewind motor is supplied with 120 volts through 8 Ω 5W resistor as shown in Fig. 7. The rewind mode of operation thus takes place.

FIG. 6

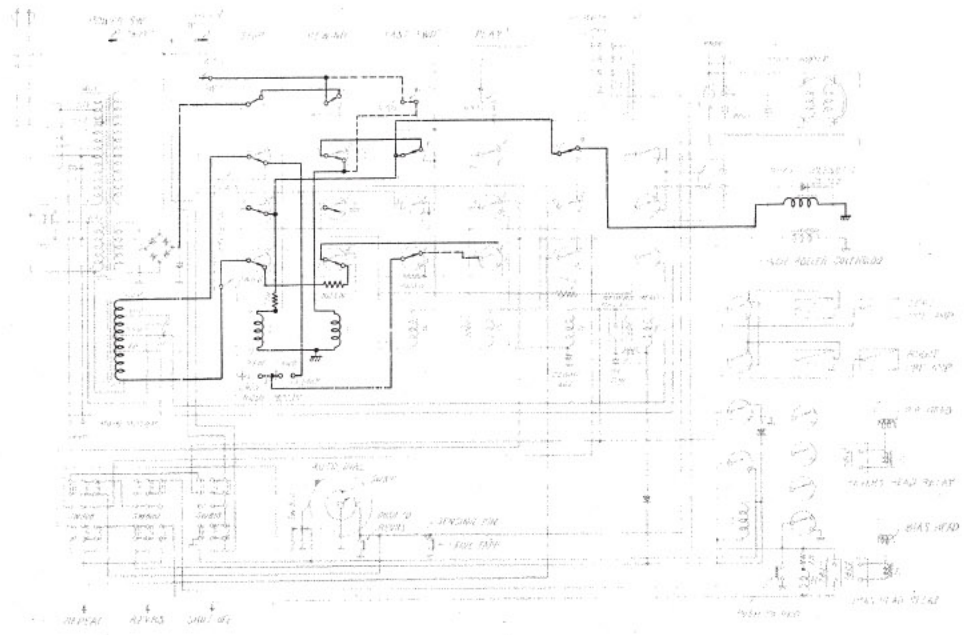
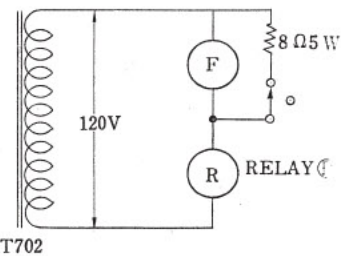

FIG. 7



F : Fast forward motor
 R : Rewind motor

REPEAT

a) REPEAT PLAY

To establish the repeat play mode of operation of the tape recorder, the repeat button on the front panel should be first depressed thereby to put the repeat switch (SW808) in red-line position as shown in Fig. 8.

At a starting end of the tape, the automatic tape counter meter dial B should be calibrated by bringing its zero point in registry with the arrow point of the dial-off button dial C, then set the set dial to its arrow pointing any desired area of the tape.....near the terminating end or any portion of the tape desired for repeated play, as illustrated in Fig. 9. Exact tape length in this case varies with the type of tape used; therefore, it is advisable to check how far the zero point of the dial B has advanced when the tape is fully taken up by fast forward and set the arrow of the dial A at that point.

Now, press the play button so that the relay control current flows as indicated by red line in Fig. 8, thus establishing the play mode of operation already described in Paragraph 2.

The dial B turns in the direction of the dotted line in Fig. 9 arrow as the tape advances.

FIG. 8

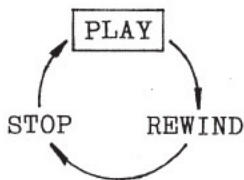
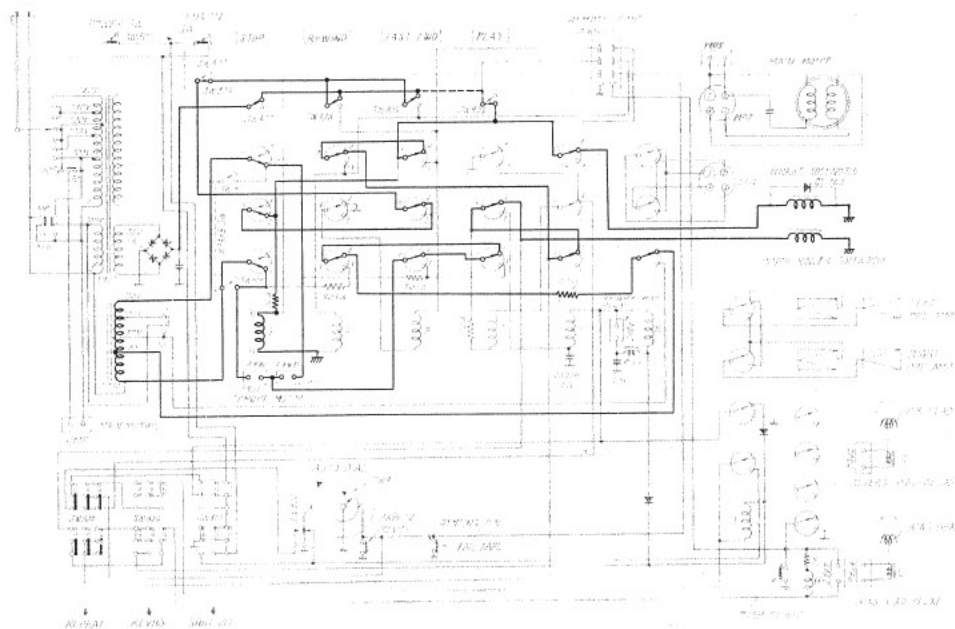
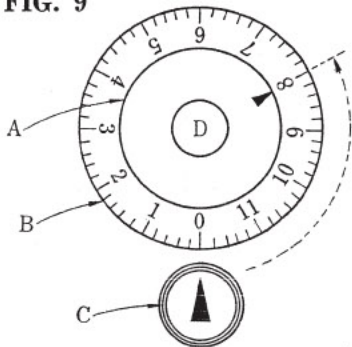

FIG. 9



b) REPEAT REWIND

The dial B, in repeat play, continues to turn counter clockwise until its "0" point comes in registry with the arrow of the dial A as shown in Fig. 11. Then, the automatic dial switch (SW816) in Fig. 10 is put in ON position and the relay control current flows in the manner shown by red line in Fig. 10 so that the relay C and relay G are energized thereby to effect the automatic rewind operation. Subsequently, the "0" point of the dial B rotates in the direction of the dotted line arrow as shown in Fig. 11 and the automatic dial switch (SW816) is put in OFF position. However, inasmuch as the relays C and G are respectively locked by contacts 7-10 and 6-2, the rewind mode of tape motion continues while the capacitor C812 (2500 μ F) is charged with 35 volts through the contact 6-2 of relay C.

When the manual reverse button (shown at D in Fig. 9) is depressed any time during the repeat mode of operation, the automatic mode of rewind operation takes place just in the same manner as it would be with the switch (SW816) put in ON position.

With a tape more than 2400 feet long, the dial-off button may be set in DIAL-OFF position and the dial B stopped, whereupon the tape may be attached at the terminating end with a foil tape for contact with the sensing pin. That foil tape causes the transport mechanism to switch on automatic rewind.

FIG. 10

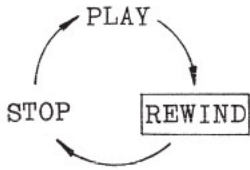
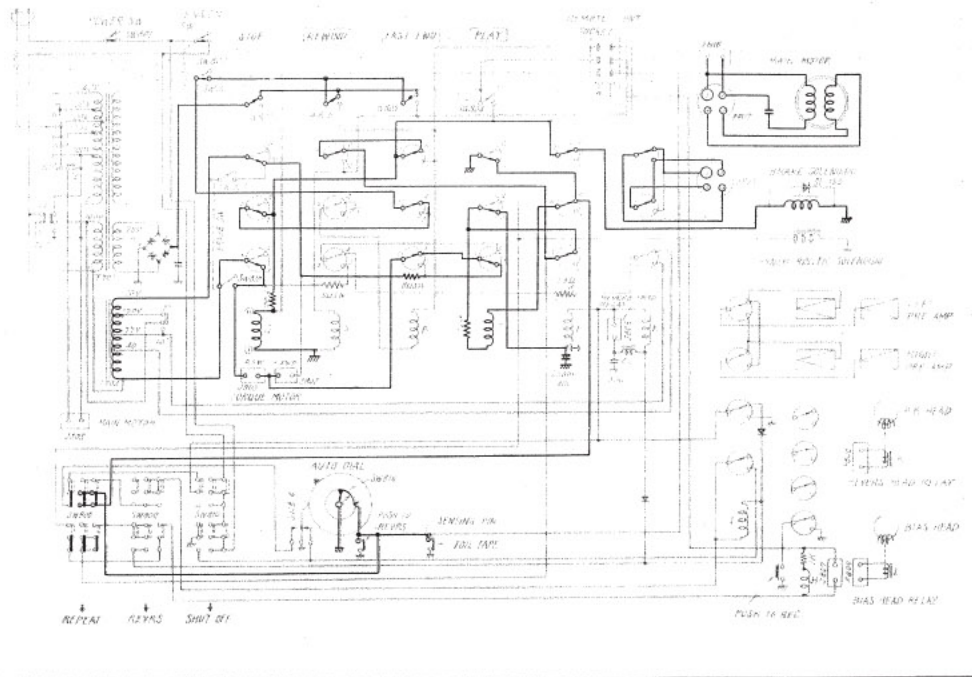
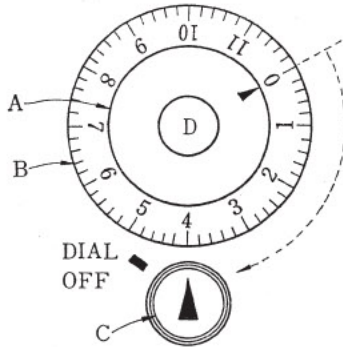

FIG. 11



c) REPEAT CYCLE STOP

While the machine is in the repeat rewind mode operation with the dial B kept in the dotted line direction as shown at Fig. 11, the "0" point of the dial B is at the same position with the arrow point of the dial C so that the switch (SW814) is put in ON position by convexity of the dial B. Consequently, the 35 volt potential established in the capacitor during repeat rewind is discharged through the relay D coil and the contacts of the switches (SW808, 810 and 814). This discharge current causes the relay D to be energized so that the current flow through the brake solenoid and pinch wheel solenoid is discontinued and then the tape stops.

It takes 3 to 4 seconds to discharge the capacitor C812, while the tape is held to a stop. As the capacitor C812 is completely discharged, the relay D automatically becomes de-energized and the transport resumes the repeat play mode of operation to begin reproduction of the tape. The operation of the machine just described repeats itself as long as the hand is off the stop button.

FIG. 12

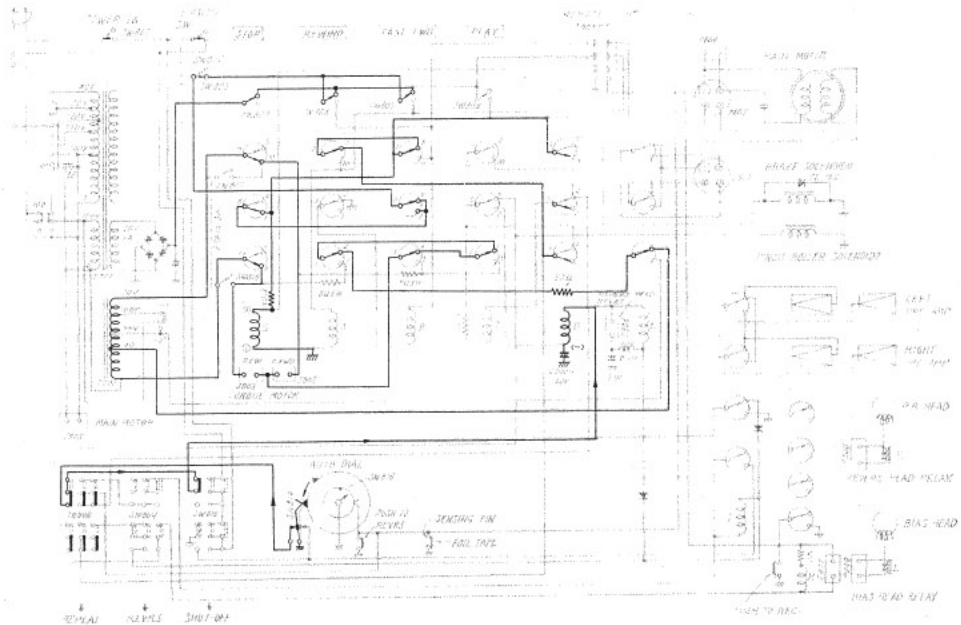
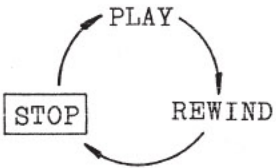

6. REVERSE

a) REVERSE CYCLE "NORMAL PLAY"

To establish a reverse play mode of operation, the reverse button on the front panel is depressed so that the reverse switch (SW809) is put in the red line position as shown in Fig. 13. In just the same manner as with the repeat play mode of operation, the "0" point of the dial B in Fig. 9 is brought in registry with the arrow marking on the dial C at an initial turn of tape roll, while the arrow of the dial A is set to a terminating end of tape or to any desired point on tape for reverse play. With the play button depressed in this manner, the relay control current flows in a manner indicated by red line in Fig. 13. However, at the instant of depressing the play button there flows a charge current through the coil of relay D into the capacitor C812 (2500 μ F) as shown by black line in Fig. 13, so that the relay D is energized for about 2 or 3 seconds blocking the flow of current through the brake solenoid and the pinch wheel solenoid. So, with the play button depressed, a few seconds must be anticipated until the charge current to the capacitor diminishes, before the relay D is de-energized to begin normal play of the tape.

FIG .13

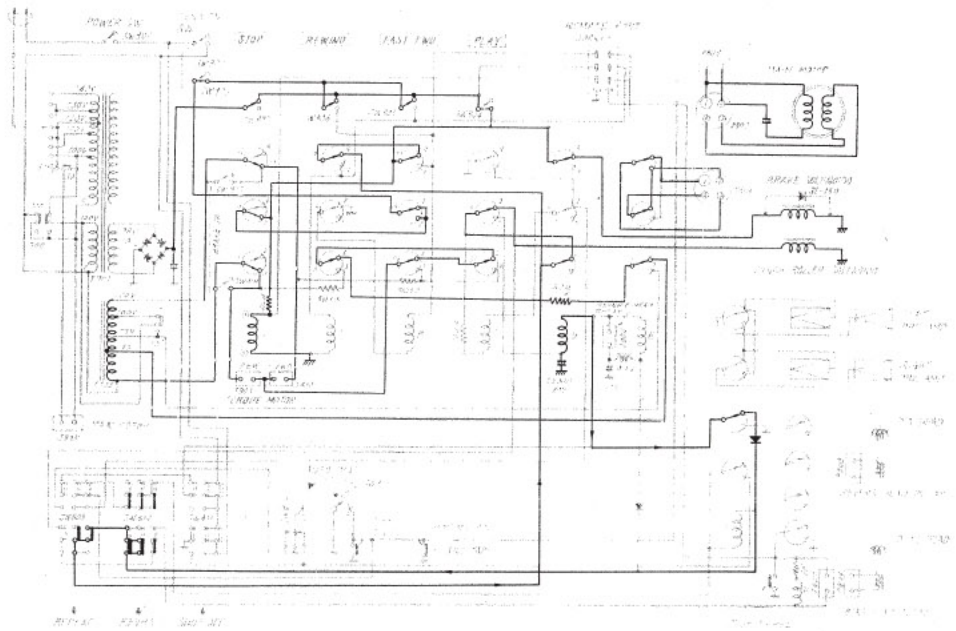

b) REVERSE CYCLE "NORMAL PLAY—→STOP"

The "0" point of the dial B rotates in the direction of the dotted line arrow in Fig. 9 according to the tape advance, and comes in registry with the arrow on the dial A, whereupon the automatic dial switch (SW816) is put in ON position and the relay I energized thereby discharging the capacitor C812 through the contact of relay I. The discharge current from the capacitor flows through the coil of relay D. The relay D thereby energized for a few seconds blocks the flow of current through the brake solenoid and the pinch wheel solenoid so that the machine is held to a stop.

The tape may be stopped for 3 or 4 seconds any time during normal play according to Paragraph. 5 by either when the manual reverse button is pressed or when the foil tape on the record tape contacts the sensing pin, just in the same manner as the switch (SW816) put in ON position. At which time, the current flows through the contact of relay I and the coil of relay E. As the relay E is thereby energized and the contacts 7-10 and 6-2 are closed in, the main motor starts to reverse.

FIG. 14

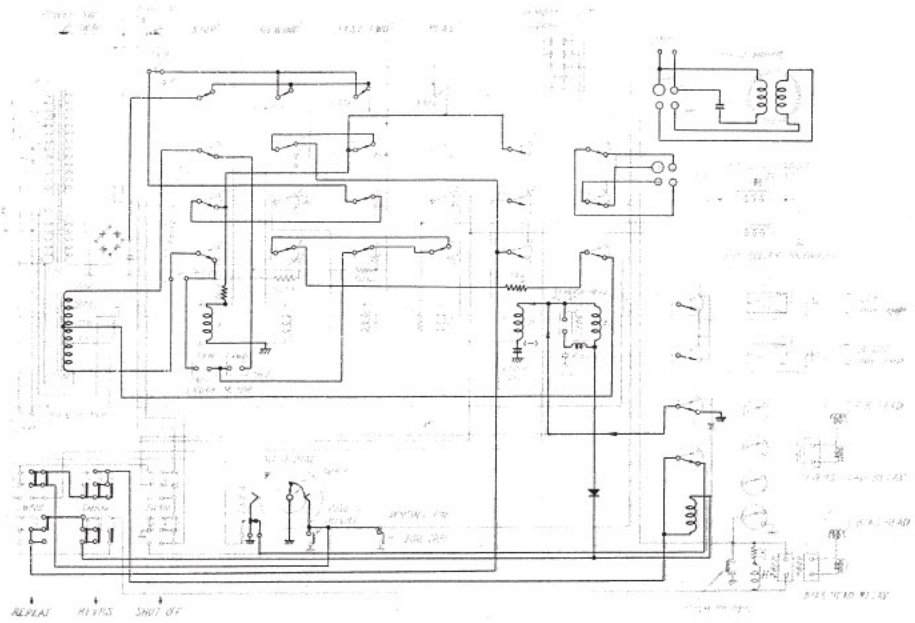
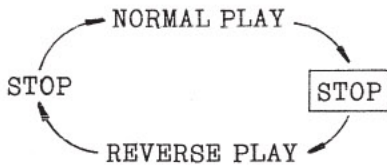
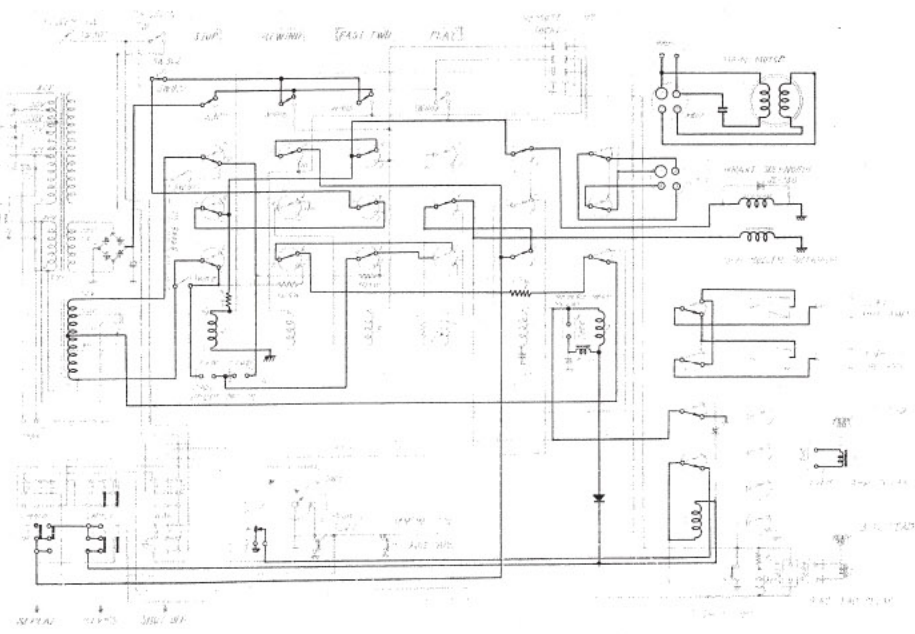
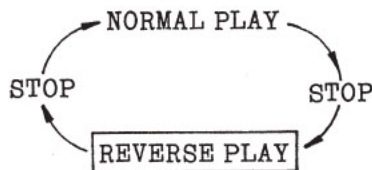

FIG. 15



c) REVERSE CYCLE "REVERSE PLAY"

With the machine held to a stop in the manner described, as the charge current diminishes with charging of the capacitor C812, the relay D becomes de-energized so that the current flows through the brake solenoid and the pinch wheel solenoid. Consequently, the tape begins reverse motion as the main motor has already reversed, thus establishing a reverse play mode of operation. The current simultaneously flows into the reverse head relay coil connected parallel with the coil of relay E, so that the playback head is lowered to reproduce the 2 and 4 tracks of the tape. The left and right pre-amplifiers may be switched over by the relay I so that the recorded signal on the left channel is reproduced without fail from the line output designated at this channel. For reverse play, tension in the tape may be adjusted by changing the voltage impressed on the torque motor in the manner illustrated in Figs. 16 and 17.

FIG. 16

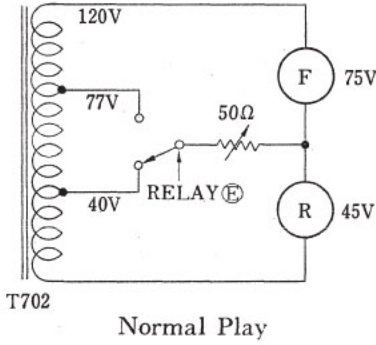
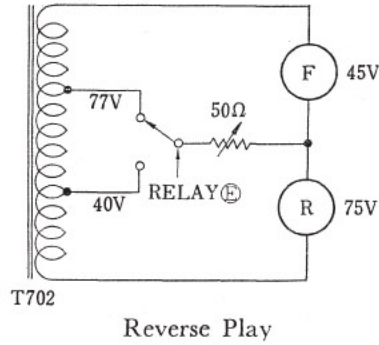

FIG. 17



F : Fast Forward Motor
R : Rewind Motor

d) REPEAT CYCLE "REVERSE PLAY" → STOP

With the tape advancement on reverse playback, the automatic tape counter meter dial B rotates in the direction of the dotted line arrow as shown in Fig. 11. As the "0" point on the dial B comes at the arrow point on the dial C, the contact of dial switch (SW814) is raised by the convexity of the dial B as illustrated in Fig. 18, and the contacts Y-Z are de-energized, hence, the relay I is de-energized as the charge current for the capacitor C812 flows through the coil of relay D as shown by red line in Fig. 18. The relay D energized prevents the current from flowing through the brake solenoid and the pinch wheel solenoid thereby holding the machine to a stop. De-energization of the relay I stops the flow of current through the relay E and coil of the reverse head relay, so that the main motor is switched back to forward rotation and the voltage applied to the torque motor switched to normal play. The preamplifiers resume a normal play mode of performance. In this manner, the relay D continues to be energized (for about 3 to 4/seconds) until the charge current of the capacitor C812 is finally diminished. As the relay D is again de-energized, the tape begins to travel in the normal play fashion.

Thus, the tape transport in the reverse cycle mode of operation repeats the sequence of Normal Play → Reverse Play → Stop.

FIG. 18

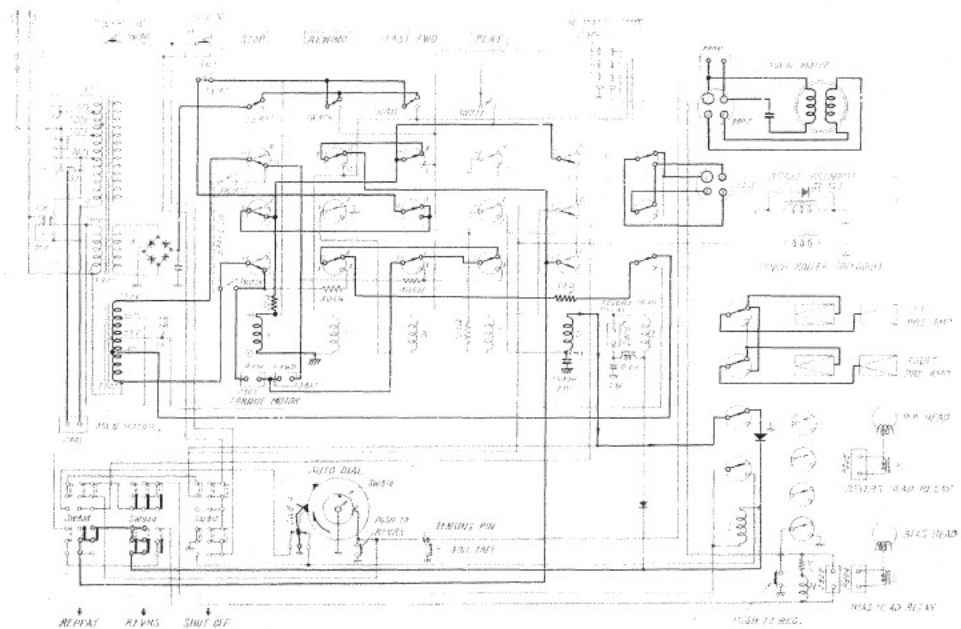
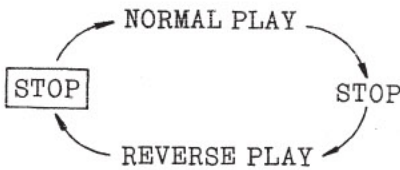

VI. MECHANISM ADJUSTMENT

1. ADJUSTMENT OF PINCH WHEEL

The proper pressure is applied to the pinch wheel by plunger action and spring tension.

The proper pressure to be applied to the capstan is between 1400-1500 grams and pressure above or below that range may cause wow and flutter. The pressure adjustment is made by turning an adjusting screw as shown by Fig. 19, where the direction of the arrow indicates increasing pressure and the other direction indicates decreasing pressure.

FIG. 19

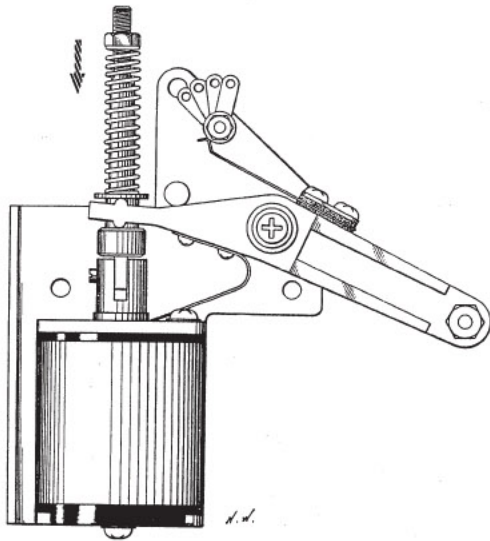

ADJUSTMENT OF TAKE-UP MOTOR

The take-up motor is a condenser ($3\mu\text{F}$) start 4-pole induction motor having optimum torque between 130 and 145 grams ranging when loaded with standard 7" reel in "normal play". (as determined with tape wound on 5" reel to a roll diameter of 60 mm using a bar gauge). The motor is run in this manner to insure that the tape is wound at a constant speed. The voltage supplied to the take-up motor during this operation may range from 75 to 80 V. A. C.

The optimum torque (viz. optimum back tension) in the "reverse play" mode of operation ranges from 40 to 50 grams with a feed voltage of about 40 to 45 V. A. C., approximately. The optimum torque when loaded with 10" reel in "normal play" is set at 210-220 grams, with a feed voltage ranging from 85 to 95 V. A. C., while in "reverse play" the torque is set at 70-80 grams with a feed voltage ranging from 55 to 65 V. A. C.

The torque can be adjusted by controlling the resistor R814 (50Ω) as shown in Fig. 20. Since this resistor is adapted for varying the voltage fed midway between the take-up motor and the supply motor, increasing the value of the resistor increases the torque of the supply motor and conversely reduces the torque of the take-up motor. With this in mind, adjustment of the torque should be made with use of a wow meter so as to set the torque to a level where wow and flutter are held to a minimum.

FIG. 20

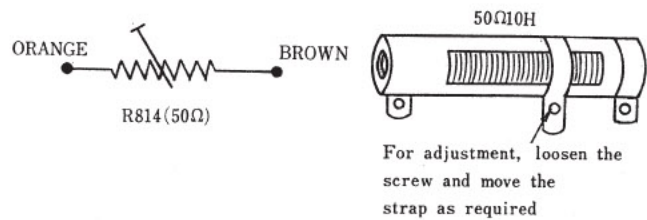

3. ADJUSTMENT OF SUPPLY MOTOR

The supply motor is, like the take-up motor, a condenser ($3\mu\text{F}$) start 4-pole induction motor.

- a) Its optimum torque when loaded with the 7" reel in "normal play" is set between 40 and 50 grams (as measured by a bar gauge with tape wound on 5" reel to a roll diameter of 60 mm). The voltage fed to the supply motor is in the range between 40 and 45 V. A. C.

The torque in "reverse play" is optimum in the range of 130 to 145 grams with the feed voltage between 75 and 80 V. A. C.

- b) The torque optimum for the loading of 10" reel in "normal play" is in the range from 70 to 80 grams (with the feed voltage ranging from 55 to 65 V. A. C.), while in the "reverse play" the optimum torque is in the range between 230 and 235 grams (with the feed voltage ranging from 85 to 95 V. A. C.).

The optimum torque is adjusted in the same manner as in the case of the take-up motor.

4. ADJUSTMENT OF HEADS

Adjustment of heads requires high-precision workmanship and for this reason re-adjustment of the heads, after delivery of tape-recorders, should be avoided without attention of the skilled engineer. In case, however, the head requires replacement, this should be done in accordance with the following procedures.

- (A) Mounting and positioning of heads (See Fig. 21)
 - i) Fix the head while loosening the control nuts ①, ②, ③ and ④, and set the tape in motion for "normal play".
 - ii) Adjust the position of the tape, using the inclination control nuts ⑤ through ⑧ so that the tape passes the centers of the tape guides ⑨, ⑩, ⑪ and ⑫, respectively.
 - iii) Now, set the machine in the "reverse play" mode of operation. Use the inclination control nuts ⑤ through ⑧ and also the level regulating screw ⑬ and adjust the position of the tape contacting the periphery of the impedance roller ⑭ so that the tape will assume the same position as in "normal play".
 - iv) To be sure that the adjustments have been properly accomplished, check the heads once again with respect to ii) and iii).
(Note that incomplete adjustment may lead to sluggish displacement of the cross-field bias head.)

FIG. 21

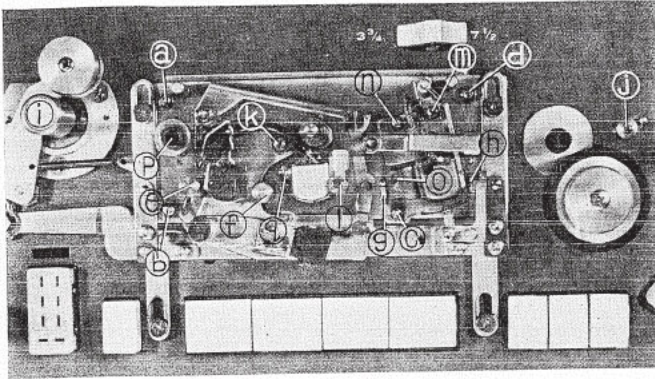

(B) Adjustment of head level

* In "normal play" mode

a) Adjust the erase head so as to be positioned about 0.15 mm above the upper edge of the tape by turning the level control screw ⑫.

b) Adjust the position of the record head by turning the level control screw ① so that the upper edge of the tape is aligned with the top edge of the CH-1 core.

c) Adjust the position of the playback head with the level control screw ⑭ so that the upper edge of the tape is brought into register with the top edge of the CH-1 core, in just the same manner as in the adjustment of the record head.

* In "reverse play" mode

a) Adjust the playback head by turning the level control screw ⑮ so that the lower edge of the tape is located at the same level with the bottom edge of the CH-2 core.

* Note: Check the tape to head contact alignment both in horizontal and vertical directions.

(C) Adjustment of playback head alignment

Playback an Ampex Alignment tape (8000 c/s) at the tape speed of $3\frac{3}{4}$ " in "normal play" mode. Set the head at a point at which maximum output is obtained by turning the alignment control screw ⑯.

Apply this test in "reverse play" also and see if the differences of output levels between the two modes of tape operation are in excess of 1 dB. If so, this should be reduced to less than 1 dB by turning the alignment control screw ⑰.

(D) Adjustment of recording bias voltage

Set the machine in "record" mode of operation. Set VTVM between the lead wire (red in colour) of the bias voltage control coil ⑱ and ground. Adjust the terminal voltages to read 40 V. A. C. by vertically moving the control screw in the coil ⑱.

(Preferably, a driver of non-conductive nature, for example, a driver made of a plastic material, should be used for this purpose. An ordinary metal driver, upon insertion into the coil ⑱, alters the value of μ , resulting in correct bias voltage readings.)

(E) Adjustment of record head alignment

Set a blank tape in motion at the tape speed of $7\frac{1}{2}$ ". Record 10,000 c/s sine waves at about -10 VU. Adjust the record angle control screw ⑲ to obtain maximum reproduce output.

* After the foregoing adjustments, the amplifiers should also be adjusted in accordance with the section of "Amplifier Adjustment" (except for the main amplifier).

5. ADJUSTMENT OF BRAKE

In order to protect the tape from being damaged when the machine comes to a "STOP", the voltages fed to both the supply motor and the take-up motor are cut off from the relays, and each brake felt is simultaneously pressed against each motor pulley to stop the rotation of the motors. Adjust the brake, by turning the brake regulating screws ⑳ and ㉑ while the machine is in its "STOP" mode as shown in Fig. 22, so that slipping tension between the left and the right motor pulleys and the brake felt is maintained between 200 and 250 grams. (Read the value with a bar gauge, using a tape wound on 5" reels to a roll diameter of 60 mm.)

FIG. 22

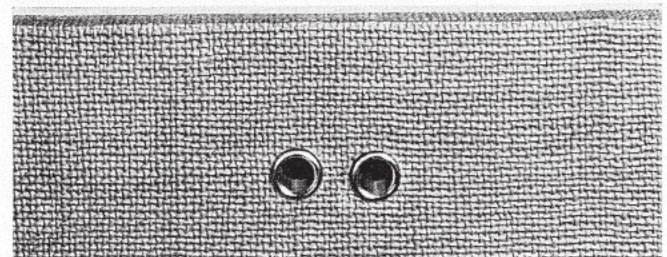
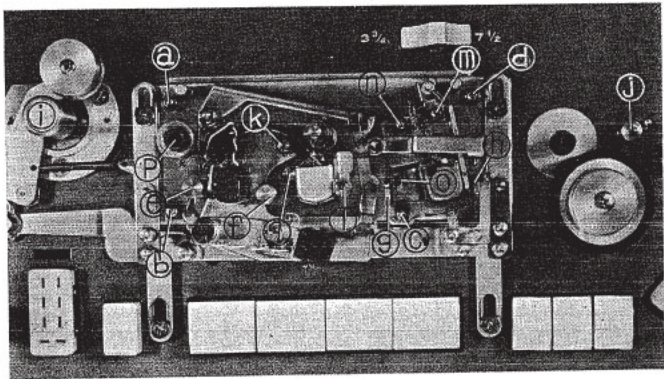

FIG. 21



(B) Adjustment of head level

* In "normal play" mode

a) Adjust the erase head so as to be positioned about 0.15 mm above the upper edge of the tape by turning the level control screw ⑫.

b) Adjust the position of the record head by turning the level control screw ① so that the upper edge of the tape is aligned with the top edge of the CH-1 core.

c) Adjust the position of the playback head with the level control screw ⑩ so that the upper edge of the tape is brought into register with the top edge of the CH-1 core, in just the same manner as in the adjustment of the record head.

* In "reverse play" mode

a) Adjust the playback head by turning the level control screw ⑩ so that the lower edge of the tape is located at the same level with the bottom edge of the CH-2 core.

* Note: Check the tape to head contact alignment both in horizontal and vertical directions.

(C) Adjustment of playback head alignment

Playback an Ampex Alignment tape (8000 c/s) at the tape speed of 3-3/4" in "normal play" mode. Set the head at a point at which maximum output is obtained by turning the alignment control screw ①.

Apply this test in "reverse play" also and see if the differences of output levels between the two modes of tape operation are in excess of 1 dB. If so, this should be reduced to less than 1 dB by turning the alignment control screw ①.

(D) Adjustment of recording bias voltage

Set the machine in "record" mode of operation. Set VTVM between the lead wire (red in colour) of the bias voltage control coil ⑬ and ground. Adjust the terminal voltages to read 40 V. A. C. by vertically moving the control screw in the coil ⑬.

(Preferably, a driver of non-conductive nature, for example, a driver made of a plastic material, should be used for this purpose. An ordinary metal driver, upon insertion into the coil ⑬, alters the value of μ , resulting in correct bias voltage readings.)

(E) Adjustment of record head alignment

Set a blank tape in motion at the tape speed of 7-1/2". Record 10,000 c/s sine waves at about -10 VU. Adjust the record angle control screw ⑨ to obtain maximum reproduce output.

* After the foregoing adjustments, the amplifiers should also be adjusted in accordance with the section of "Amplifier Adjustment" (except for the main amplifier).

5. ADJUSTMENT OF BRAKE

In order to protect the tape from being damaged when the machine comes to a "STOP", the voltages fed to both the supply motor and the take-up motor are cut off from the relays, and each brake felt is simultaneously pressed against each motor pulley to stop the rotation of the motors. Adjust the brake, by turning the brake regulating screws ③ and ④ while the machine is in its "STOP" mode as shown in Fig. 22, so that slipping tension between the left and the right motor pulleys and the brake felt is maintained between 200 and 250 grams. (Read the value with a bar gauge, using a tape wound on 5" reels to a roll diameter of 60 mm.)

FIG. 22

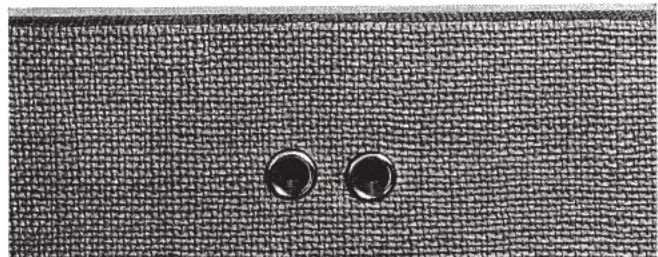

6. ADJUSTMENT OF PINCH WHEEL MUTE SWITCH

The switch is gang-operated with the pinch wheel for constructing a voice circuit only under PLAY conditions. Accordingly, improper adjustment of the switch contacts may result in reproduction failure or troublesome noise during fast rewind.

Adjust the switch contact position so that the contact is OFF when the pinch wheel is in contact with the capstan, and ON when the pinch wheel is not operated.

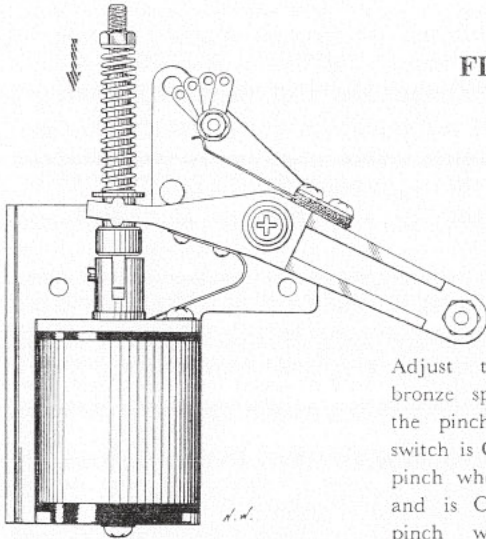

FIG. 23

Adjust this phosphor bronze spring so that the pinch wheel mute switch is OFF when the pinch wheel is operated and is ON when the pinch wheel is not operated.

7. ADJUSTMENT OF TENSION SWITCH

This tension switch is operative interlockingly with the tension arm in such fashion that only when the arm is located between ① and ② as shown in Fig. 24, the switches SW-802 and SW-803 are tripped into "ON" position thereby actuating the relays. Therefore, loosen the fastening screws ③ and ④ of the switches (SW-802 and SW-803) and displace them with fingers to adjust them so that only when the tension arm is located between ① and ②, the lever ⑤ will press the button SW-802 and conversely, the button SW-903 will emerge.

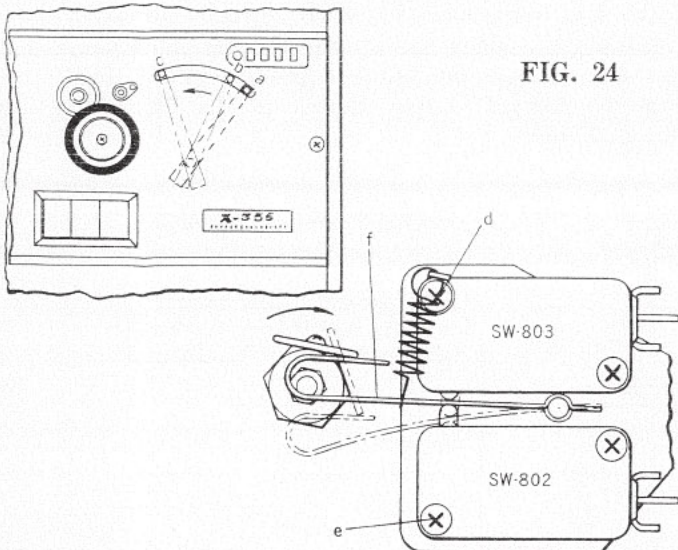

FIG. 24

8. ADJUSTMENT OF REEL BASE HEIGHT

When the reel base height is improper, the tape rubs against the reel causing tape wear on one edge or even broken tape.

Loosen the height adjustment screws (a)---(two used) of the motor pulley and align the reel center with the tape center by moving the motor pulley (b) manually. Tighten the adjustment screws. (See Fig. 25.)

FIG. 25

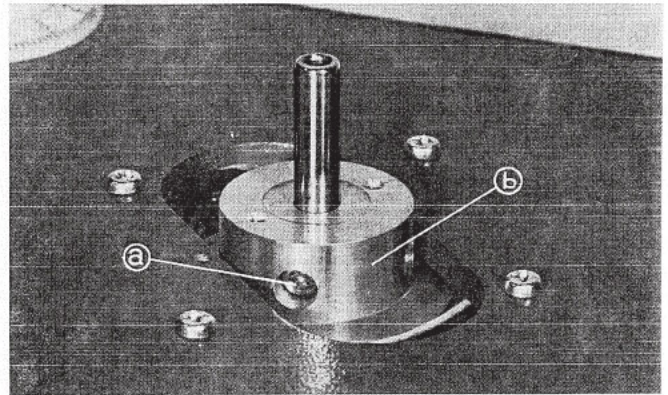

6. ADJUSTMENT OF PINCH WHEEL MUTE SWITCH

The switch is gang-operated with the pinch wheel for constructing a voice circuit only under PLAY conditions. Accordingly, improper adjustment of the switch contacts may result in reproduction failure or troublesome noise during fast rewind.

Adjust the switch contact position so that the contact is OFF when the pinch wheel is in contact with the capstan, and ON when the pinch wheel is not operated.

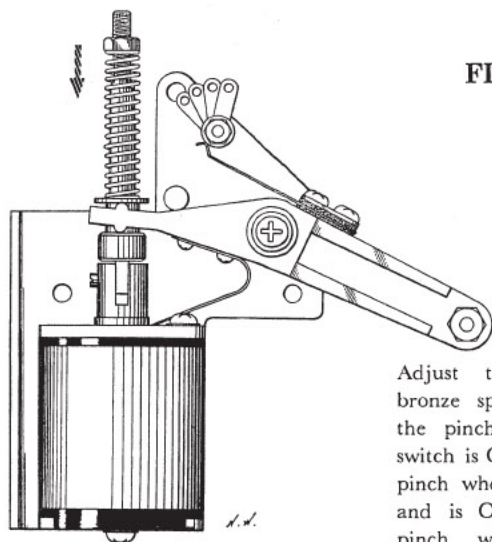

FIG. 23

Adjust this phosphor bronze spring so that the pinch wheel mute switch is OFF when the pinch wheel is operated and is ON when the pinch wheel is not operated.

7. ADJUSTMENT OF TENSION SWITCH

This tension switch is operative interlockingly with the tension arm in such fashion that only when the arm is located between ① and ② as shown in Fig. 24, the switches SW-802 and SW-803 are tripped into "ON" position thereby actuating the relays. Therefore, loosen the fastening screws ③ and ④ of the switches (SW-802 and SW-803) and displace them with fingers to adjust them so that only when the tension arm is located between ① and ②, the lever ⑤ will press the button SW-802 and conversely, the button SW-903 will emerge.

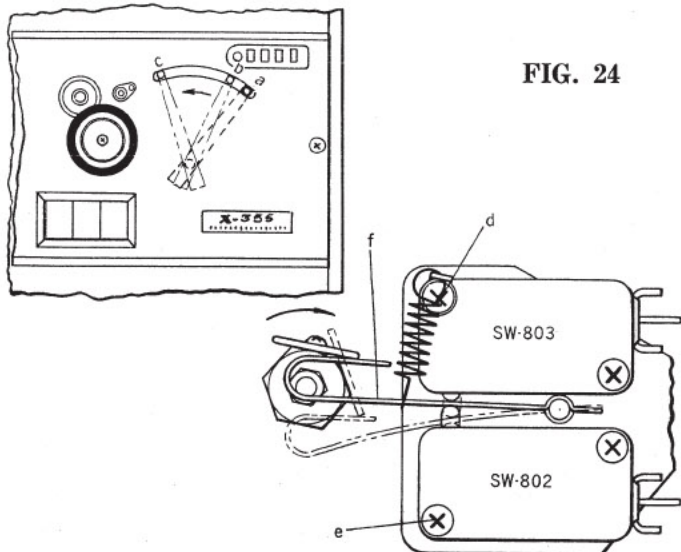

FIG. 24

8. ADJUSTMENT OF REEL BASE HEIGHT

When the reel base height is improper, the tape rubs against the reel causing tape wear on one edge or even broken tape.

Loosen the height adjustment screws (a)---(two used) of the motor pulley and align the reel center with the tape center by moving the motor pulley (b) manually. Tighten the adjustment screws. (See Fig. 25.)

FIG. 25

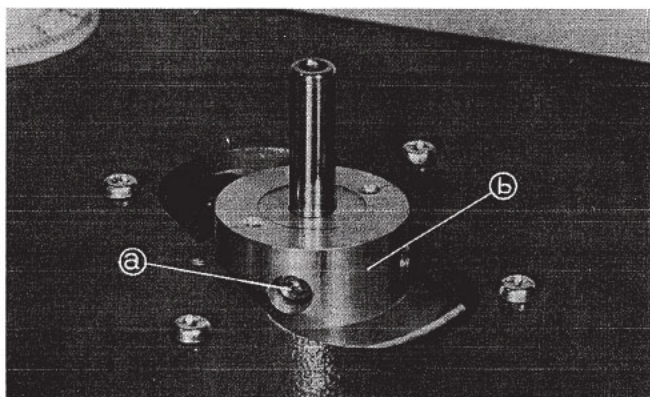

VII. AMPLIFIER ADJUSTMENT

1) ADJUSTMENT OF PLAYBACK OUTPUT LEVEL (PRE-AMPLIFIER)

- Connect VTVM (use one with Milli-Volt scale) to line output as shown in Fig. 26.
- Playback an Ampex 250 c/s test tape (7.5"/s). Adjust VR201 (semi-fixed resistor, 20 kΩ) so that the Line Output Level of Channel 2 indicates 1.228 V. At this point, the VU meter should indicate 0 VU ± 0.5 VU.
- Then, adjust the Line Output Level of Channel 1 in the same manner as followed in the adjustment of the level of CH-2. This adjustment should be done, however, while pushing the playback head downwards by about 0.5 mm with fingers after setting the Head Selector either to the 3-2 monaural position or to the stereo position. Compare both Line Output Levels after adjustment. By reading the 355 VU meter, the level of CH-1 will be about 0.5 to 1 dB lower than that of CH-2.

FIG. 26

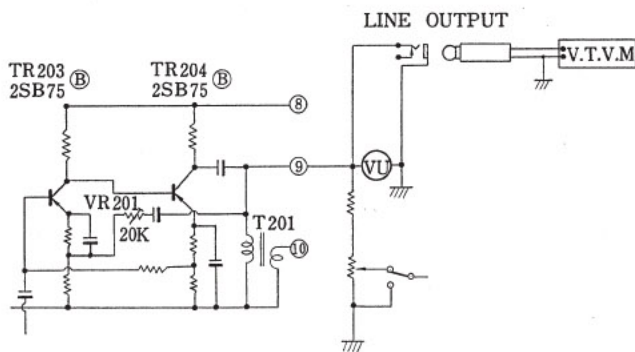

2) ADJUSTMENT OF RECORDING EQUALIZATION CHARACTERISTICS

- Set a testing blank tape (SCOTCH-111) on the machine.
- Set Equalizer Switch in the 7-1/2" position.
- Supply 1,000 c/s sine wave of the Audio Frequency Oscillator to the Line Input of the X-355 through the Attenuator (ATT).
- Set the X-355 in "record" mode. Set the tape into motion at the tape speed of 7-1/2", and set the Playback Output Button in "IN" position (thereby placing the machine in the playback monitoring for recording).

FIG. 27

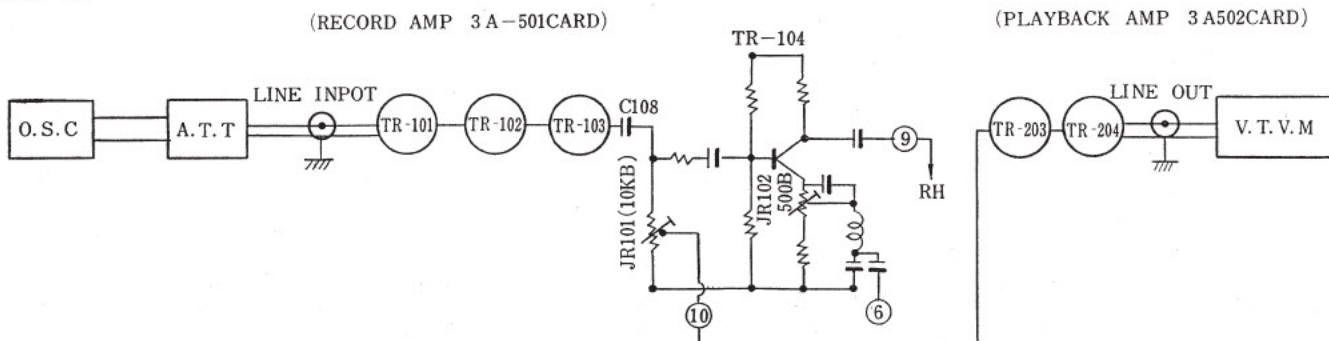

- Operate the Line Volume and the ATT to adjust the input level so that the level of the Line Output reads about 200 mV (-16 dB).
- After this adjustment, shift the signal frequency of Audio Frequency Oscillator to 10,000 c/s. Operate the resistor VR-102 (500 Ω (B) semi-fixed resistor) to adjust the Line Output Level of X-355 so as to assume the same value as that in 1,000 c/s (approximately 200 mV).

"Check":

In the (f) state, shift the signal frequency of Audio Frequency Oscillator to 18,000 c/s, and it will be noted that the Line Output Level of the X-355 is set at -6dB or lower, as compared with the level at 1,000 c/s. Furthermore, when Equalizer Switch has been shifted to 3-3/4" with the tape running at the speed of 3-3/4", the Line Output Levels for 1,000 c/s and 10,000 c/s will be equal.

In the event that the equalization characteristics should deviate from the above standards after proper adjustments, such deviation may be due to mal-adjusted heads, and hence the heads should be readjusted according to the instructions on the Adjustment of Heads.

3) ADJUSTMENT OF RECORDING INPUT LEVEL

- Connect VTVM to Line Output.
- Supply 1,000 c/s sine wave of Audio Frequency Oscillator to the Line Input of the X-355.
- Set a testing blank tape (SCOTCH-111) on the machine. Set the X-355 in "record" mode, and set the tape in motion at the speed of 7-1/2".
- Set the Playback Output Button in "IN" position.
- Manipulate the Line Volume (10 kΩ A) to adjust the Recording Input Level so that the indicator voltage of VTVM connected to Line Output reads 1.228 V.
- In the state of (e), re-set the Playback Output Button. Then, set the Record Output Button in "IN" position and operate VR-101 (10 kΩ B) so that the indicator of the VU meter of the X-355 will point at the volume unit of "0".

* If this later adjustment has been correctly accomplished, the VU meter should indicate the same value also when the operation of the output button is shifted from the Record Output Button to the Playback Output Button.

4) **ADJUSTMENT OF D. C. BIAS FOR POWER TRANSISTORS [2SB338 (A)]**

Set the ammeter as shown in Fig. 28. Operate VR-401 and VR-402 so that the amperage at absence of signal will be 50 mA.

FIG. 28

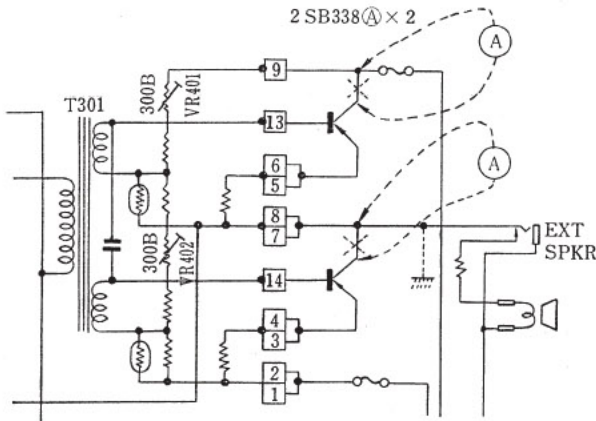

(Adjustment will be facilitated by the insertion of a short-circuited plug into the External Speaker Jack.)

Speaker Output Jack and adjust the loudness volume until the VTVM indicates "0" dB. Then, remove the standard tape. Measure noise level under the same conditions and adjust by bending the shield metal located opposite to the playback head to read a lower noise point on the meter.

FIG. 30

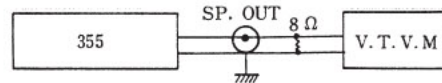

5) **ADJUSTMENT OF RECORDING BIAS VOLTAGE**

This has been already described under the paragraph entitled, "Adjustment of Heads". Note that VTVM is set as shown in Fig. 29, and XL (reactance) of the Recording Bias Control Coil 3A-VAC is adjusted to accomplish this purpose.

FIG. 29

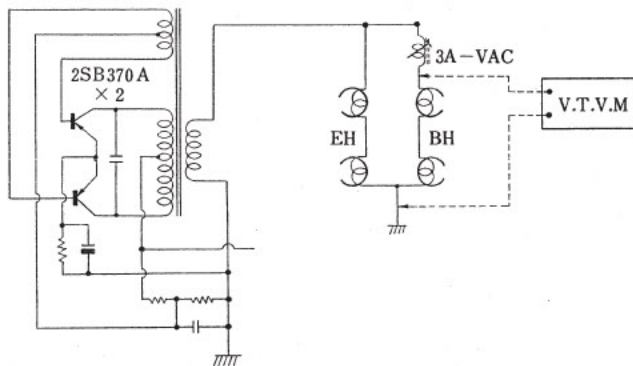

6) **S/N ADJUSTMENT**

Playback a standard 250 cps (or 1,000 cps) sine wave tape recorded on a standard tape recorder (the tone switch should be set in the Flat Position). Connect VTVM (mV scale type) with 8Ω resistor to the

VIII. MAINTENANCE

All moving parts have been lubricated before packing. After every 1500~2000 hours operation, lubrication is required for the following items. The grade of oil chosen should be good quality sewing machine oil.

The autodial gear portions should be lubricated with a small amount of high quality grease.

The surfaces of the erase, record, bias and playback heads, the tape guide roller, the capstan and the pinch wheel often become contaminated.

These surfaces should be cleaned from time to time with a soft cloth (gauze, etc.) dipped in alcohol or chlorothenenil.

Extreme care should be taken in order not to allow the adherence of oil or grease on the drive belt, as this may cause slipping. Should oil or grease stick to the drive belt, clean with a soft cloth soaked in a cleaning solvent such as alcohol. In this case, other items in contact with the belt must also be cleaned.

For lubrication, refer to Fig. 31.

LUBRICATION POINTS

Main motor	replace two bearings
Left and right motors	replace a bearing
Capstan shaft	2 drops
Impedance roller shaft	2 drops
Pinch wheel shaft	2 drops
Selector	1 drop

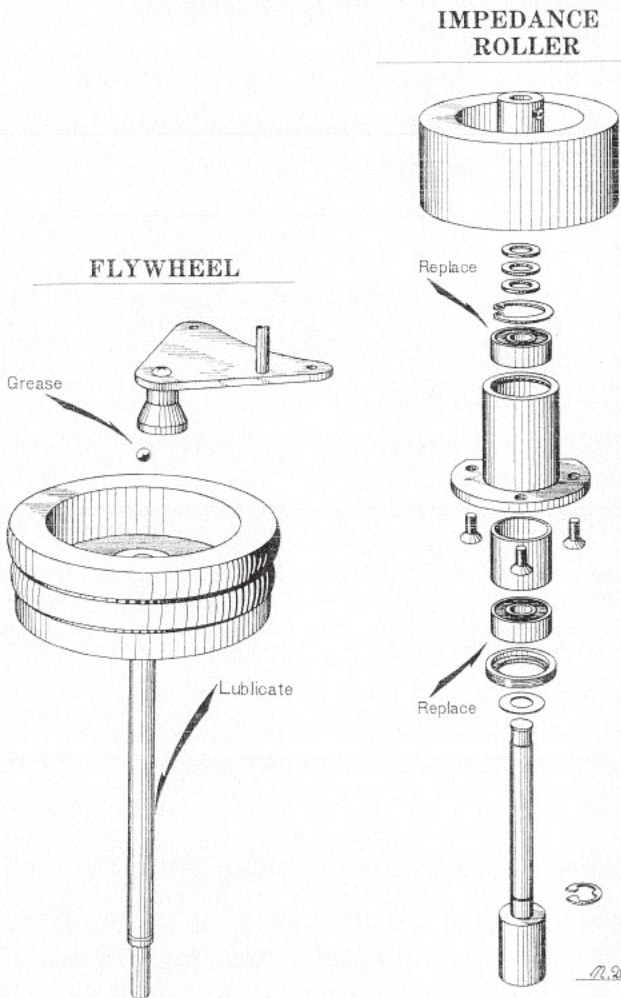
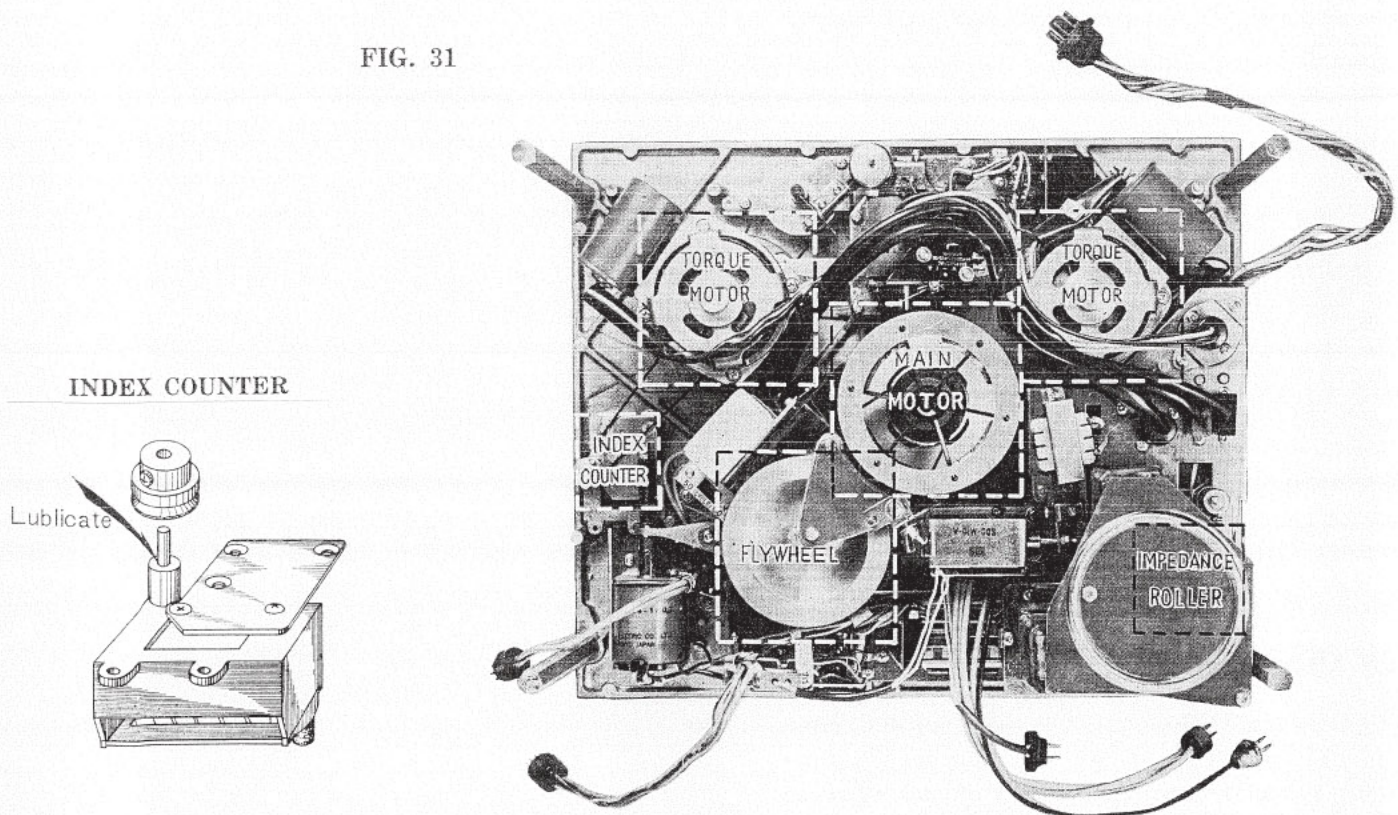

FIG. 31



VIII. MAINTENANCE

All moving parts have been lubricated before packing. After every 1500~2000 hours operation, lubrication is required for the following items. The grade of oil chosen should be good quality sewing machine oil.

The autodial gear portions should be lubricated with a small amount of high quality grease.

The surfaces of the erase, record, bias and playback heads, the tape guide roller, the capstan and the pinch wheel often become contaminated.

These surfaces should be cleaned from time to time with a soft cloth (gauze, etc.) dipped in alcohol or chlorothenonil.

Extreme care should be taken in order not to allow the adherence of oil or grease on the drive belt, as this may cause slipping. Should oil or grease stick to the drive belt, clean with a soft cloth soaked in a cleaning solvent such as alcohol. In this case, other items in contact with the belt must also be cleaned.

For lubrication, refer to Fig. 31.

LUBRICATION POINTS

Main motor	replace two bearings
Left and right motors	replace a bearing
Capstan shaft.....	2 drops
Impedance roller shaft	2 drops
Pinch wheel shaft.....	2 drops
Selector.....	1 drop

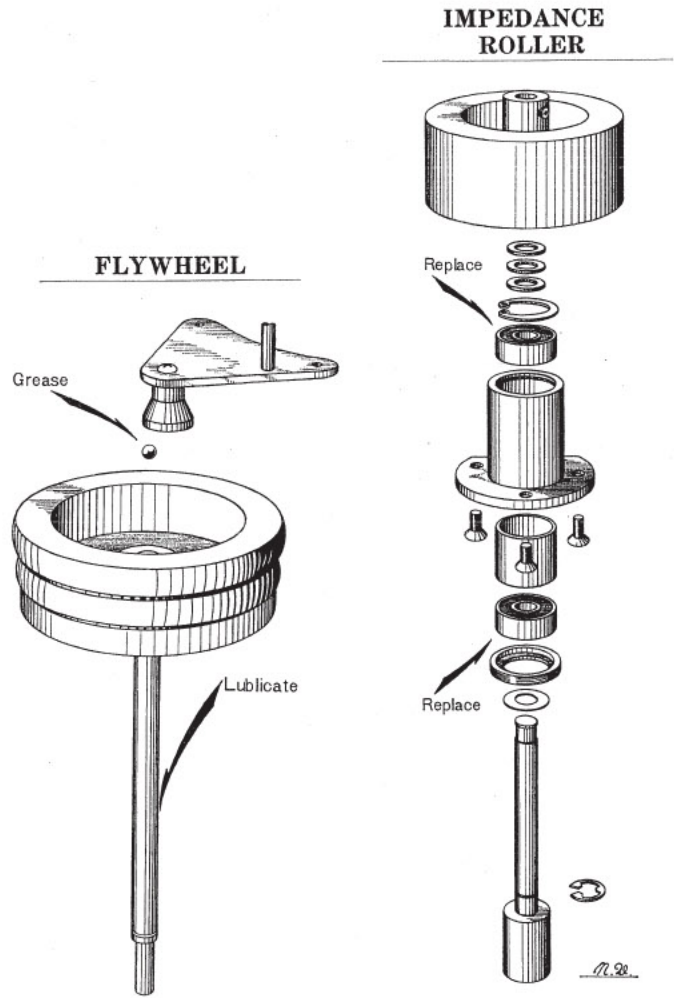
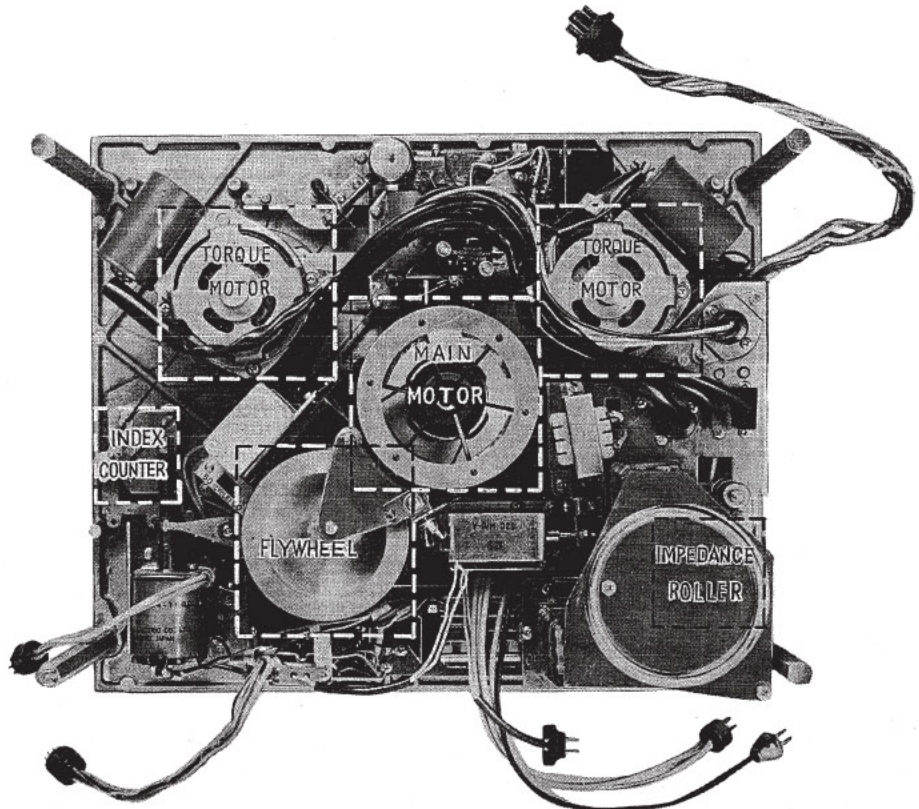
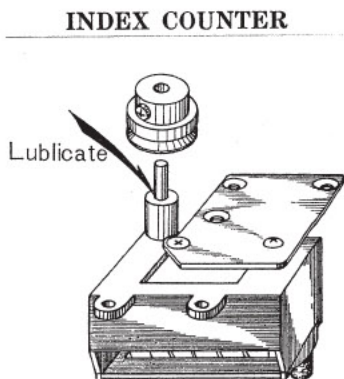
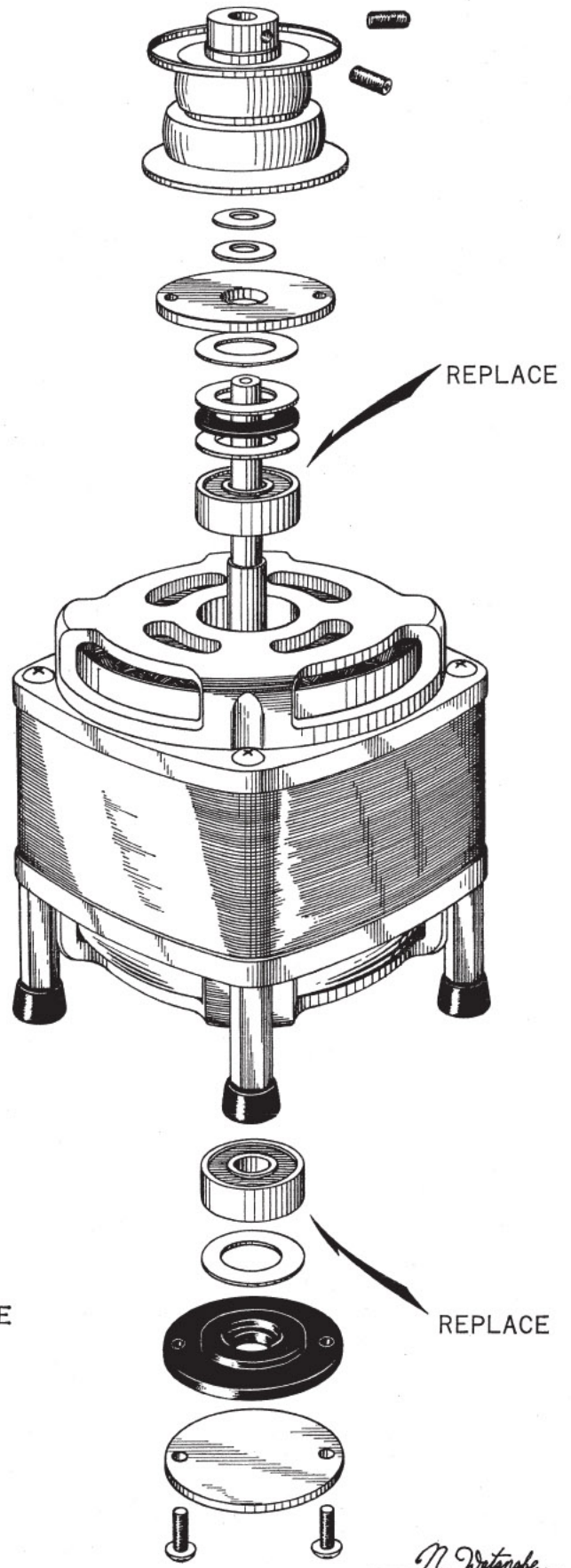
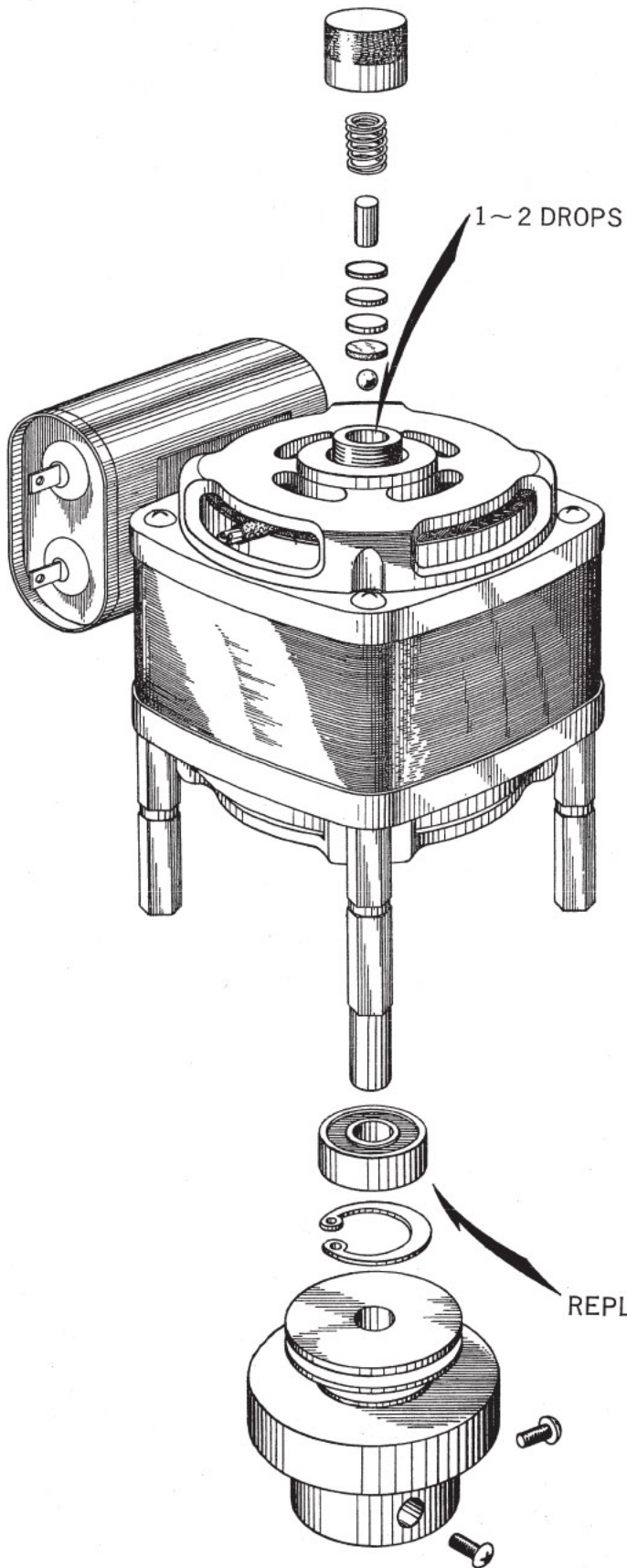

FIG. 31



TORQUE MOTOR

MAIN MOTOR



M. Detorade

IX. REPLACEMENT PARTS TABLE

Parts No.	Nomenclature	Parts No.	Nomenclature	Parts No.	Nomenclature
MECHANISM					
MAIN MOTOR BLOCK					
01-001	Main Motor Comp.	03-002	Erase Head Comp.	03-014a	Shifter Lever, C
002	Motor Chassis, Main Motor	002a	Shift Table, Erase Head	014b	Shifter Pin
003a	Motor Pulley	002b	Metal, Up-Down Table	015	Shield Plate, Head
003b	Screw, without Head	002c	μ Spring	016	Switch Table
004a	Motor Fan	002d	Plate, Erase Head	017	4T Cam
004b	Ring, Motor Fan	002e	Pin, Cam	018	Shaft, Head Wheel
004c	Screw	003	Recording Head Comp.	019	Head Gear, C
005	External Shield Plate, Motor	003a	LP Angle Table	020	Head Gear, A
006a	Flywheel Comp.	003b	LP Table	021	Shield Plate, H Switch
006b	4 mm Ball Bearing	003c	Height Adjusting Plate A, Recording Head	022	Rotary Switch
006c	Thrust Metal	003d	Height Adjusting Plate B, Recording Head	023	Shield Plate
007	Main Metal Case	003e	Angle Screw, Recording Head	024	Plunger A (SDC-M10A) Comp.
008	Plate, Main Shaft	003f	Screw, Up-Down Recording Head	024a	Plunger A
009	Prop A, Flywheel	004	Bias Head Comp.	024b	Shift Joint, Playback Head
010a	Plate, Flywheel	004a	Shift Table, Bias Head	025	Plunger B (SDC-M10B) Comp.
010b	Belt Change Lever	004b	Metal, Field Table	025a	Plunger B
010c	Screw	004c	Side Plate, Bias Head	025b	P Joint, Bias Head
010d	Prop, Belt Change Lever	004d	Lever, Bias Head	026a	Pull Shaft, Bias Head
010e	Screw	004e	Connecting Plate	026b	Pull Metal, B
011	Drive Belt	004f	(-) Screw 2.3 x 4.5	026c	Pull Lever
012a	Speed Change Lever Comp.	005	Playback Head	026d	Spring, DA
012b	Spring F, Lever	005a	Shift Table, Playback Head	027	2P Plug
012c	Screw	005b	Shaft, Up-Down Playback Head	028	4P Plug
013	18P Slide Switch (FS-601N)	005c	Reverse Spring	029	4P Plug (T Type)
014a	6P Slide Switch, Cycle Change (FS-201NB)	005d	3 mm closed Nut	HEAD COVER BLOCK	
014b	Name Plate, Cycle Change	005e	Angle Table, Playback Head	04-001	Head Wheel
014c	Screw	005f	Shift Metal, Playback Head	002	3A Cover, A
014d	Washer	005g	Angle Screw, Playback Head	003a	3A Cover, B
015	MP Condenser	005h	Height Adjusting Plate, Playback Head	003b	Screw 4 x 12
016	Resistor 1/4P 10K ohms	005i	Angle Adjusting Spring	PUSH BUTTON BLOCK	
017	2P Plug	005j	Up-Down Lever, Playback Head	05-001	Main Push Button
018	4P Plug (T Type)	005k	Spring, Head Plunger	002	Spring, Mechanism Push Button
WIND MOTOR BLOCK					
02-001	Wind Motor Comp.	005l	3 mm Nut	003	Guide, Push Button
002	Rewind Motor Comp.	005m	Prop, Playback Head Shift	004	Prop, Push Button
003	2P Plug	005n	Spring, Playback Head Shift	005a	Chassis, Switch
004	MP Condenser 4 μ 300 VAC	006a	Table, Head	005b	Rubber Bush
005	Supply Pulley	006b	Stopper	006a	Micro Switch
006	Take-up Pulley	007a	4T Tape Guide, B	006b	Plate A, Micro Switch
HEAD BLOCK					
03-001	Head Assembly Comp.	007b	Tape Guide, A	006c	Plate B, Micro Switch
		007c	Micron Guide, A	006d	Collar, Micro Switch
		007d	Micron Guide, B	006e	Shaft, Micro Switch
		008	Hum Bucking Coil	006f	Washer Pin
		009	Tape Guide Comp.	007	Push Button, Power Switch
		009a	Screw	008	Power Switch
		009b	Z Guide, A		
		009c	Washer A, Tape Guide		
		009d	Washer B, Tape Guide		
		009e	Bearing		
		009f	Z Guide, B		
		009g	Z Arm		
		009h	Spring, Z		
		009i	Z Lever, A		
		009j	Z Metal		
		010	Slider Lever, E		
		011a	Slider Lever, D		
		011b	Stop Spring, B		
		012	Screw, Amplifier Lever		
		013	Slider Lever		

Parts No.	Nomenclature	Parts No.	Nomenclature	Parts No.	Nomenclature
05-009	Push Button, Automatic Switch	07-004a	Spring, Brake	09-004b	Spring, Micro Switch
010	3AF Block Comp.	004b	Spring Holder, A	005	Micro Switch
010a	3AF Print plate	004c	Spring Holder, B	006	Table, Cut-off Micro Switch
010b	Auto. Chassis	005a	Brake Adjusting Screw	IMPEDANCE BLOCK	
010c	2P Socket (B Type)	005b	Brake Adjusting Spring	10-001	Z Roller
010d	Tip Jack	006a	Brake Lever Comp.	002	Screw, Z Bearing
010e	Tip Plug	006b	Shaft, Brake Lever	003	Bearing 608VUC2E
010f	8P Plug	007a	Brake Plunger	004	Z Case
011	8P Johnson Socket, for Remote Control Comp.	007b	Relay York	005	Bearing Collar
012	Silcon Diode SW-05a	007c	Connecting Screw	006	Pin
RELAY BLOCK		007d	Table, Micro Switch	007	Impedance Wheel
06-001	Relay Printed Plate Block Comp.	007e	Micro Switch	PINCH WHEEL BLOCK	
002	Relay Printed Plate	008	4P Plug (T Type)	11-001a	(+) Screw Flat Mould 4x12
002a	22 Multi Jack	009	Tip Connector Jack	001b	Cap, Pinch Wheel
002b	11P Socket (O Type)	REPEATER BLOCK		001c	Pinch Wheel
002c	2P Socket (B Type)	08-001a	Dial Button	001d	Shaft, Pinch Wheel
002d	4P Socket (B Type)	001b	Spring, Repeater Knob	002	Base B, Pinch Wheel
003a	MP Condenser 0.5 μ 350 VDC (220 VAC)	001c	Repeater Knob, B	003	Shaft, Pinch Wheel Arm
003b	MP Condenser 0.1 μ 350 VDC (220 VAC)	001d	Repeater Dial	004a	Arm, Pinch Wheel
003c	MP Condenser 0.5 μ 150 VDC	001e	Spring, Clamp	004b	Spring, Pinch Wheel
003d	MP Condenser 0.1 μ 150 VDC	001f	Spur Gear	005	Relay Comp.
003e	Oil Condenser 0.02 μ 400 VDC	001g	Dial Stop Plate	005a	Relay York
003f	Electrolytic Condenser 50 μ 50V	001h	Repeater Switch	005b	Plunger
003g	Wired Resistor 5L 8 ohms J	001i	Switch Angle, A	005c	Tip Connector Plug
003h	Resistor 1P 100 ohms J	002a	Repeater Change Knob	006a	Pinch Wheel Pull Bar Comp.
003i	Resistor 1/4P 50 ohms K	002b	Escutcheon, Repeater Change Knob	006b	Washer
004	Lug Type Condenser 2500 μ 40V	002c	Change Lever	006c	Pressure Spring, Pinch Wheel
005	9P Plug	002d	Angle, Change Lever	006d	Nut
006	P Printed Plate Chassis Comp.	002e	Shaft	006e	Stop Pin B, Pinch Wheel
006a	Table, P Socket	003	Timer Chassis Comp.	007a	Short Switch B
006b	Choke Transformer, Reverse Plunger (0.3H 0.1A)	004a	Insulator Spacer	007b	Prop B, Short Switch
006c	Base, P Chassis	004b	Insulator Table, Switch	007c	4P Plug
007	Resistor 50 ohms 10H	004c	Switch Plate, B	COUNTER BLOCK	
008a	55 Prop.	005a	Repeater Gear	12-001	Counter Four Digit Comp.
008b	55 Prop. (Hexagonal)	005b	Washer	002	Plate, Counter
009	69 Prop.	005c	Pressure Spring	003a	Pulley, Counter
010	Side Plate, P Chassis	005d	Clank Gear	003b	Screw
011	Relay Switch DC 24V	005e	Screw, without Head	004	Belt, Counter
012	Relay Support Plate, B	006a	Metal Fitting, Shaft	POWER BLOCK	
013	Print Plug	006b	Repeater Gear	13-001	Power Chassis
014	6P Plug	006c	Spur Gear	002	Power Transformer
BRAKE BLOCK		007a	Repeater Worm with Shaft	003	Auto. Transformer, Motor
07-001	Brake Relay Table Comp.	007b	Washer	004	Rectifier SPN-01
002	Brake Connect Plate Comp.	007c	Timer Pulley		
003a	Brake Band	007d	Timer Belt		
003b	Switch Angle, A	008a	Angle, UZ Socket		
003c	Switch Angle, B	008b	UZ Socket		
		008c	Condenser Q-AK1		
		008d	Tip Connector Jack		
		TENSION ARM BLOCK			
		09-001	Tension Arm Comp.		
		001a	Guide Pin, Tension Arm		
		001b	Metal, Tension Lever		
		001c	Nut, Tension Lever		
		001d	Cushion, Tension Arm		
		004a	Lever, Micro Switch		

Parts No.	Nomenclature	Parts No.	Nomenclature	Parts No.	Nomenclature
13-005	Rectifier 12C-2	14-003f	Screw	16-009a	2-pole E Jack
006	US Socket, TV-318	003g	Reel Table Ring	009b	Name Plate, Jack
007	9P Mould Socket, Black	004	Speed Change Knob, B	010	4P Connector Socket
008a	6P Slide Switch ESS-22C-NB, Cycle Change	005a	Screw, without Head	011	US Plug
008b	Name Plate, Cycle Change	005b	R Guide	012	Tip, Speaker
009	3P Lug Plate	005c	Prop, R Guide	013	Small Rubber
010	2P Lug Plate	005d	Cover, R Pin	014	Speed Nut
011a	Lug Type Condenser 500 μ 50V	005e	R Pin	015a	2P Fuse Holder
011b	Tubular Type Condenser 500 μ 50V	005f	Insulator Ring	015b	Fuse, 1A
012a	Wired Resistor 1.5L 0.2 ohms K	CASE BLOCK		016a	3P Lug Plate, Small
012b	Wired Resistor 2L 120 ohms K	15-001	Case Comp.	016b	3P Lug Plate, 31 L1
012c	Wired Resistor 2L 100 ohms K	001a	Case	016c	4P Lug Plate, 41 L2
012d	Wired Resistor 5L 105 ohms K	002a	3A Ventilator	016d	4P Lug Plate, 42 L1
013	12 mm Rubber Bush	002b	(+) Screw Truss 3 \times 6	016e	5P Lug Plate, Small
014	Power Connector Plate	003	Cord Holder	017	Transistor 2SB 338(A) or 2SB 471
015	Power Selector Knob	004	Sound Mirror	018a	Tubular Type Electrolytic Condenser 500 μ F 25V
016	Power Change Socket	005a	Amplifier Base Panel, Case	018b	Tubular Type Electrolytic Condenser 200 μ F 25V
017	Hexangular Prop, Selector	005b	Catch, Amplifier Base Panel	018c	Tubular Type Electrolytic Condenser 1000 μ F 25V
018	6P Slide Switch ESS-22C-NC, Power Change	006a	Rubber Foot	019a	Resistor 1/4P 47 ohms K
019	Prop, Switch	006b	(+) Screw Truss 4 \times 20	019b	Resistor 1/4P 220 ohms J
020	Hexangular Prop, Selector	007a	Escutcheon	019c	Resistor 1/4P 820 ohms
021	Arm, Power Selector	007b	(+) Screw Truss 3 \times 8	019d	Resistor 1/4P 6.8K ohms K
022a	Plate, Power Selector	008	Speaker Russ Plate	019e	Resistor 1/4P 10K ohms K
022b	3 mm Closed Nut	009	Speaker 6DJ1	019f	Resistor 1/4P 100K ohms
023	6P Slide Switch ESS-22C-NB, Reel Size	010	Russ Plate, A	019g	Wired Resistor 3WL 8 ohms K
024	3A Fiber	011	Patent Name Plate	AMPLIFIER FRAME BLOCK	
025a	Fuse Post	012	Support Angle, Case	17-001	Amplifier Frame
025b	Fuse, 3A	013	Catch	002	Support Angle, Amplifier Frame
026	Cord Support	014	Hinge	003a	Prop A, Amplifier Panel
027	AC Cord	AMPLIFIER		003b	Prop B, Amplifier Panel
028	Rubber Bush, AC Cord	AMPLIFIER CHASSIS BLOCK		004a	Prop A, Switch
PANEL BLOCK		16-001	Amplifier Chassis, A	004b	Prop B, Switch
14-001	Mechanism Panel	003	27 Prop	005	VU Meter (VH-30)
001a	(+) Screw Truss 4 \times 4	004a	Holder A, Multi Jack	006	Spring, VU Meter
001b	Washer	004b	10P Multi Jack	007a	Pilot Lamp, Swan Type
001c	Prop, Mechanism Panel	005a	Holder B, Multi Jack	007b	Lamp Socket
002	Mechanism Frame	005b	18P Multi Jack	008a	Recording Button
002a	(+) Screw Truss 4 \times 25	006a	Supporter, Printed Plate	008b	Lever, Reecording Lock
003a	Reel Holder	006b	Holder, Printed Plate Supporter	009a	2-pole E Jack (MIC Input)
003b	Screw Flat 3 \times 8	007a	4P Jack	009b	Holder, Jack
003c	Rubber, Reel Table	007b	Table, 4P Jack	010a	3-pole E Jack (Headphone Input)
003d	Plate, Reel Table	008a	4P Socket	010b	Holder, Jack
003e	Spring, Reel Table	008b	Holder, 4P Socket	011a	Seasaw Switch (Function Switch, Tone Switch, Speaker ON/OFF Switch)
				011b	Seasaw Switch (Equalizer Switch)

Parts No.	Nomenclature
17-012	Push Button Switch (Equalizer Switch)
013a	3P Lug Plate, Small
013b	5P Lug Plate, Small
014a	Variable Resistor, Duplex
014b	Variable Resistor
015a	Resistor 1/4P 10K ohms
015b	Resistor 1/4P 39K ohms
016	Tubular Type Oil Condenser 0.02 (M) 400WV

AMPLIFIER CARD BLOCK RECORD CARD

18-001	Record Card Comp.
002	Printed Plate, Record Card
003	Holder, Record Card
004a	Transistor 2SB 443 (A)
004b	Transistor 2SB 75 (B)
005a	Tubular Type Electrolytic Condenser 30 μ F 3V
005b	Tubular Type Electrolytic Condenser 100 μ F 3V
005c	Tubular Type Electrolytic Condenser 100 μ F 6V
005d	Tubular Type Electrolytic Condenser 10 μ F 10V
005e	Tubular Type Electrolytic Condenser 100 μ F 10V
005f	Tubular Type Electrolytic Condenser 10 μ F 25V
005g	Mylar Condenser 0.033 μ F 50V K
005h	Mylar Condenser 0.047 μ F 50V K
005i	Mylar Condenser 0.1 μ F 50V K
006a	Resistor 1/4P 100 ohms K
006b	Resistor 1/4P 220 ohms J
006c	Resistor 1/4P 300 ohms J
006d	Resistor 1/4P 560 ohms J
006e	Resistor 1/4P 1.2K ohms J
006f	Resistor 1/4P 1.5K ohms J
006g	Resistor 1/4P 3K ohms K
006h	Resistor 1/4P 3.3K ohms K
006i	Resistor 1/4P 10K ohms K
006j	Resistor 1/4P 10K ohms J
006k	Resistor 1/4P 15K ohms J
006l	Resistor 1/4P 22K ohms J
006m	Resistor 1/4P 100K ohms J
007a	Half Fixed Resistor 500 ohms (B)
007b	Half Fixed Resistor 10K ohms (B)
008	Peaking Coil 300 μ H
009	Screw, (+) 2.3 \times 5
010	2.3 mm Nut

PLAYBACK CARD

19-001	Playback Card Comp.
002	Printed Plate, Playback Card
003	Holder, Playback Card
004a	Transistor 2SB 443 (A)
004b	Transistor 2SB 75 (B)
004c	Transistor 2SB 75 (F)
005a	Tubular Type Electrolytic Condenser 30 μ F 3V
005b	Tubular Type Electrolytic Condenser 100 μ F 3V
005c	Tubular Type Electrolytic Condenser 100 μ F 6V

Parts No.	Nomenclature
19-005d	Tubular Type Electrolytic Condenser 10 μ F 10V
005e	Tubular Type Electrolytic Condenser 100 μ F 10V
005f	Tubular Type Electrolytic Condenser 10 μ F 25V
005g	Tubular Type Electrolytic Condenser 50 μ F 25V
005h	Mylar Condenser 0.01 μ F 50V J
005i	Mylar Condenser 0.22 μ F 35V K
006a	Resistor 1/4P 100 ohms K
006b	Resistor 1/4P 220 ohms J
006c	Resistor 1/4P 270 ohms J
006d	Resistor 1/4P 300 ohms J
006e	Resistor 1/4P 560 ohms J
006f	Resistor 1/4P 1.5K ohms J
006g	Resistor 1/4P 1.8K ohms K
006h	Resistor 1/4P 2.2K ohms K
006i	Resistor 1/4P 3K ohms K
006j	Resistor 1/4P 3.3K ohms K
006k	Resistor 1/4P 4.7K ohms J
006l	Resistor 1/4P 6.8K ohms K
006m	Resistor 1/4P 10K ohms K
006n	Resistor 1/4P 10K ohms J
006o	Resistor 1/4P 15K ohms J
006p	Resistor 1/4P 100K ohms J
007	Half Fixed Resistor 20K ohms (B)
008	Headphone Transformer 7K ohms : 8 ohms
009	Screw, (+) 2.3 \times 5
010	2.3 mm Nut

RELAY CARD

20-001	Relay Card Comp.
002	Printed Plate A, Relay Card
003	Printed Plate B, Relay Card
004	Silicon Diode SE-05a
005	Tubular Type Electrolytic Condenser 200 μ F 25V
006a	Resistor 1/4P 220 ohms J
006b	Resistor 1/4P 1K ohms K
007	Compound Body 120 ohms+0.1 μ F 250V
008a	Relay FBV153b
008b	Socket
008c	Metal Holder
009	9P Socket, Printed Plate
010	Angle, Relay
011	Holder, Relay Card
012	Screw, (+) 2.3 \times 5
013	2.3 mm Nut

MAIN AMPLIFIER CARD

21-001	Main amplifier Card comp.
002	Printed Plate, Main Amplifier Card
003	Radiative Plate
004	Radiative Plate, Transistor
005	Holder, Printed Plate
006a	Tubular Type Electrolytic Condenser 500 μ F 3V

Parts No.	Nomenclature
21-006b	Tubular Type Electrolytic Condenser 10 μ F 6V
006c	Tubular Type Electrolytic Condenser 500 μ F 6V
006d	Tubular Type Electrolytic Condenser 50 μ F 10V
006e	Mylar Condenser 0.015 μ F 50V K
006f	Mylar Condenser 0.022 μ F 50V K
006g	Mylar Condenser 330P 35WV K
007a	Resistor 1/4P 12 ohms K
007b	Resistor 1/4P 150 ohms K
007c	Resistor 1/4P 150 ohms J
007d	Resistor 1/4P 470 ohms J
007e	Resistor 1/4P 1K ohms J
007f	Resistor 1/4P 1.2K ohms J
007g	Resistor 1/4P 3.3K ohms K
007h	Resistor 1/4P 5.6K ohms J
007i	Resistor 1/4P 30K ohms J
007j	Resistor 1/4P 15K ohms J
007k	Resistor 1/4P 100K ohms K
007l	Resistor 1/2P 680 ohms K
008	Wired Resistor 3/4WL 0.5 ohms K
009	Half Fixed Resistor 300 ohms (B)
010	Driver Transformer N-35-2052
011a	Transistor 2SB 75 (A)
011b	Transistor 2SB 370A (A)
012	Thermister 13D27
013	Screw, (+) 2.3 \times 5
014	2.3mm Nut

OSCILLATOR CARD

22-001	Oscillator Card Comp.
002	Printed Plate, Oscillator Card
003	Chassis, Oscillator
004	Prop A, Switch
005	Radiative Plate
006	Transistor 2SB 370A (B)
007a	Tubular Type Electrolytic Condenser 100 μ F 6V
007b	Oil Condenser 0.01 μ F 400WV
008a	Resistor 1W 36 ohms J
008b	Resistor 1/4P 20K ohms J
008c	Resistor 1/4P 3K ohms J
009	Oscillator Coil
010	Plastic condenser 0.06 μ F 400WV
011	Screw, (+) 3 \times 12
012	M3 Nut
013	Screw, (+) 3 \times 8
014	Screw, (+) 3 \times 5
015	M3 Nut

AMPLIFIER PANEL BLOCK

23-001	Amplifier Panel
002	Escutcheon, VU Meter
003	Escutcheon B, Recording Lamp
004	Escutcheon, Recording Button
005a	Knob A, Amplifier
005b	Knob B, Amplifier
006	Push Button (P.B./REC. OUTPUT)

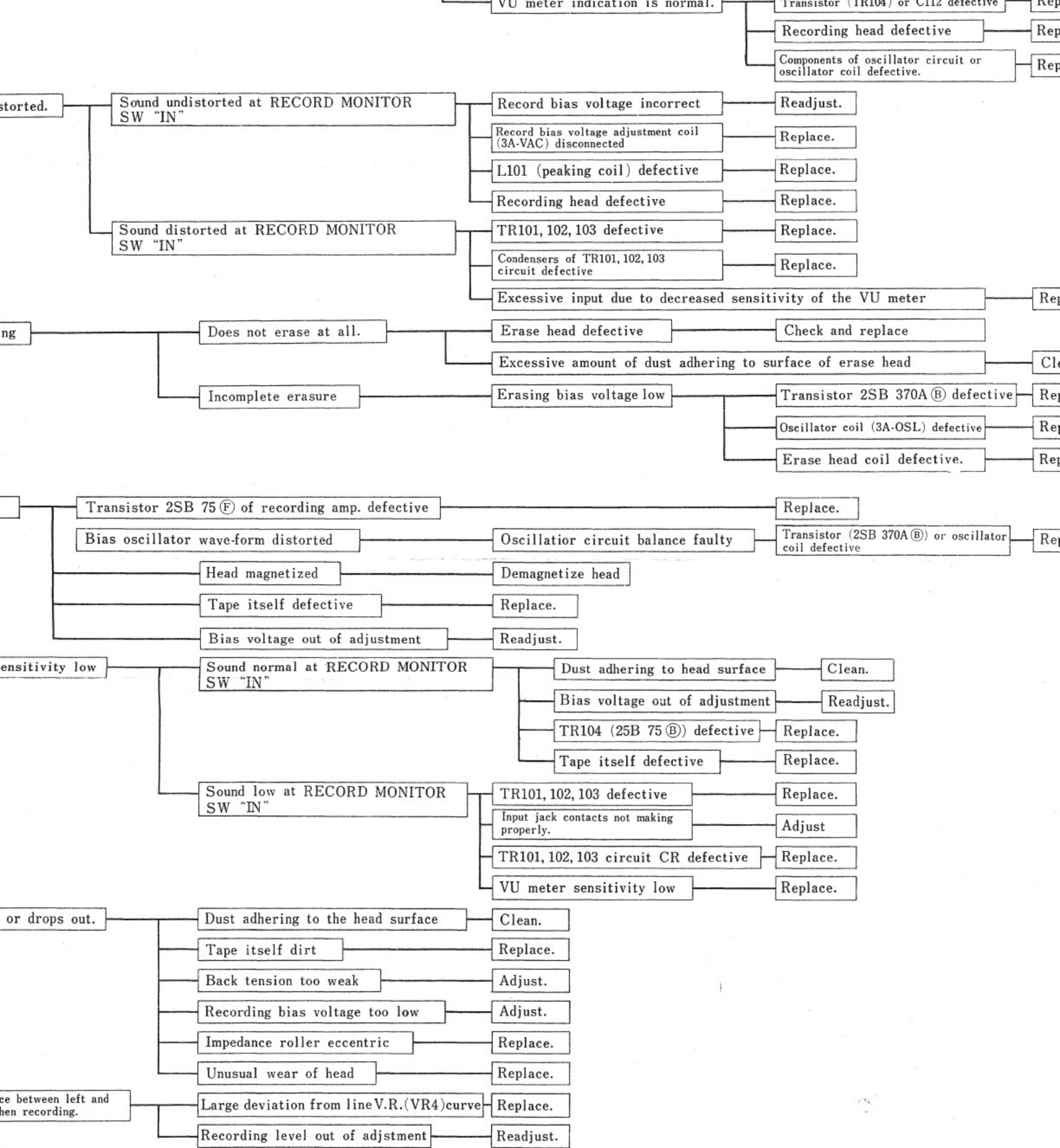

TROUBLE IN BOTH RECORDING AND PLAYBACK (AMPLIFIER)

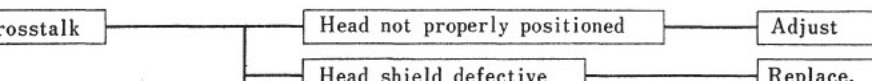

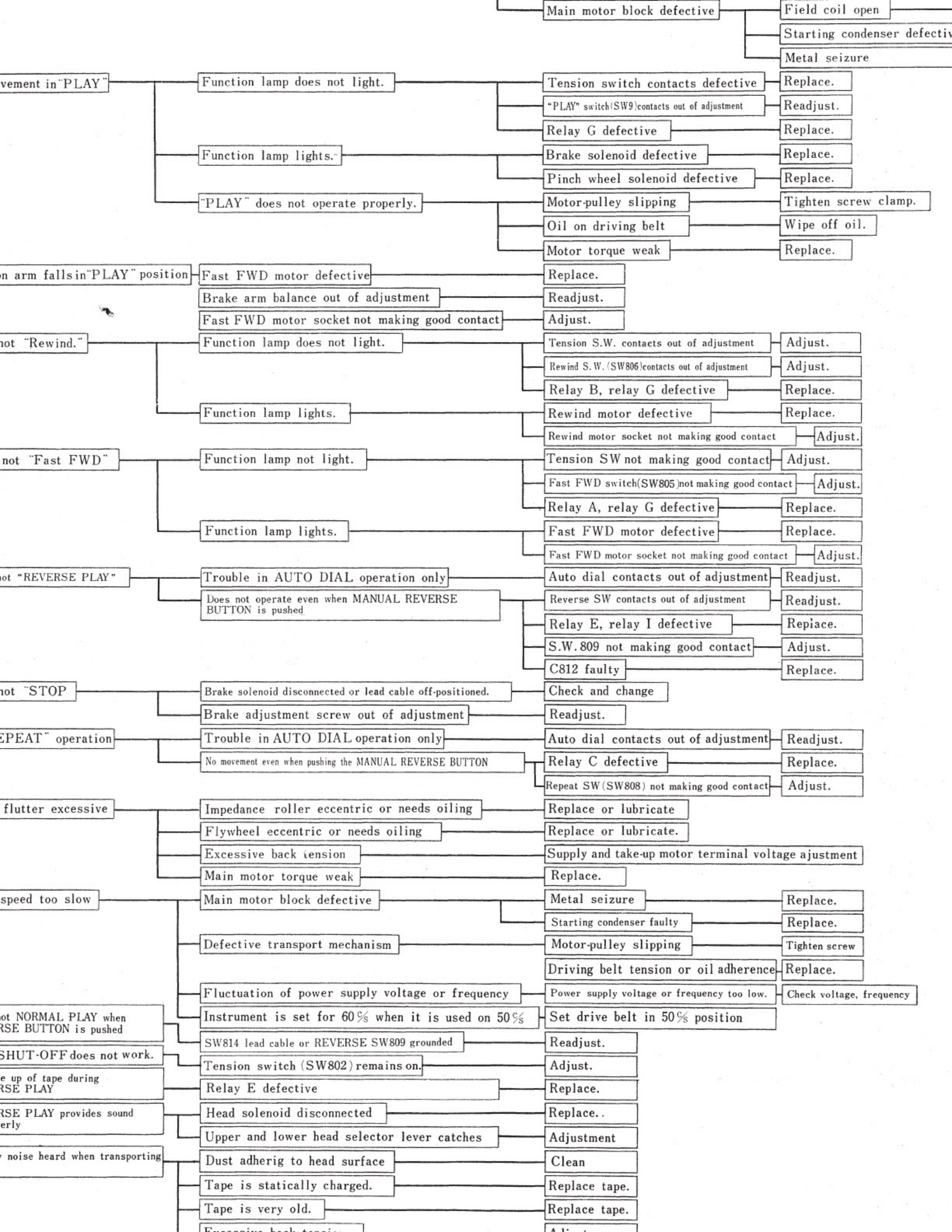

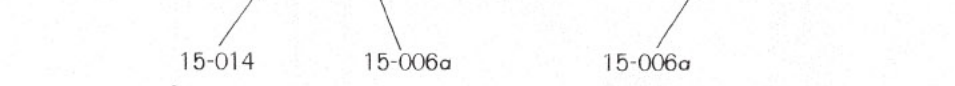
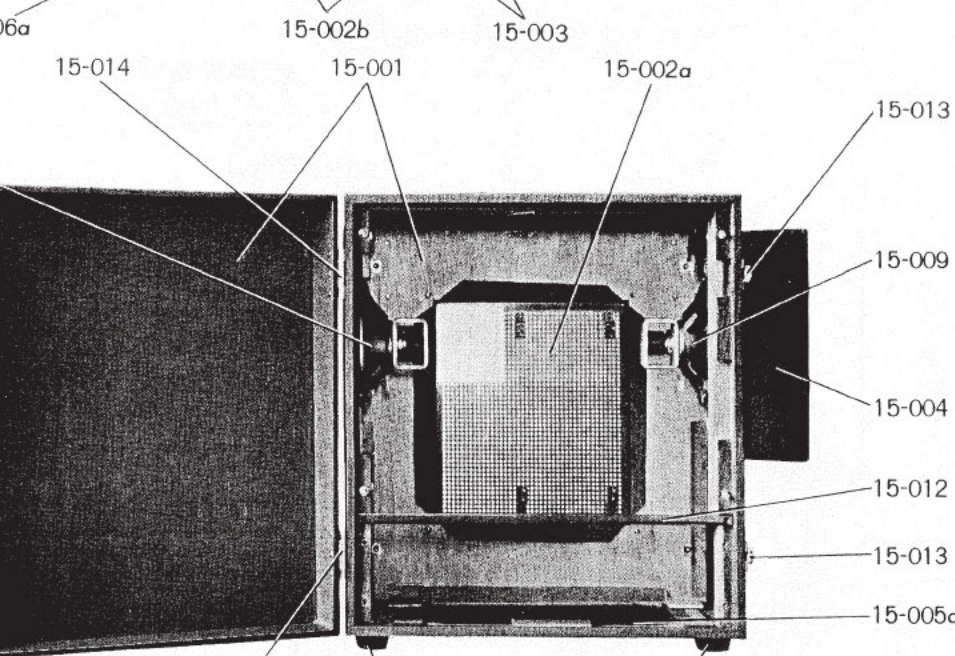
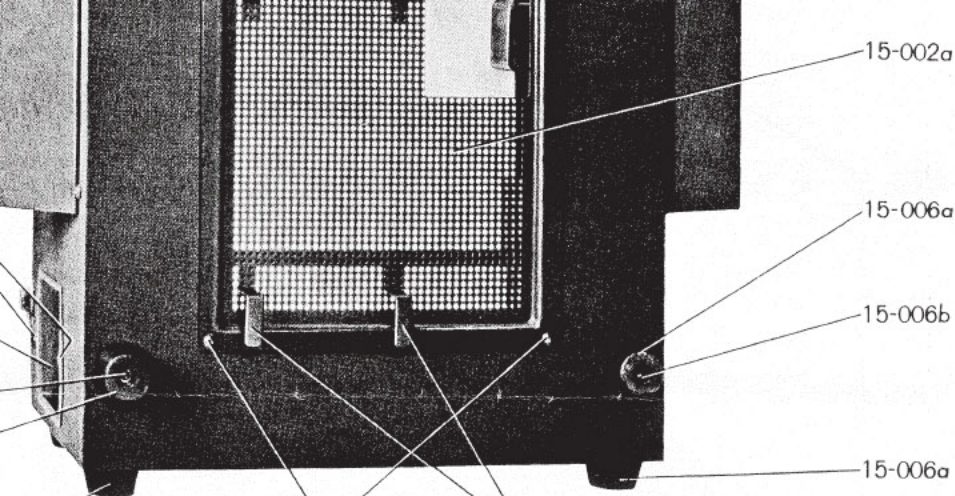

Power Block I

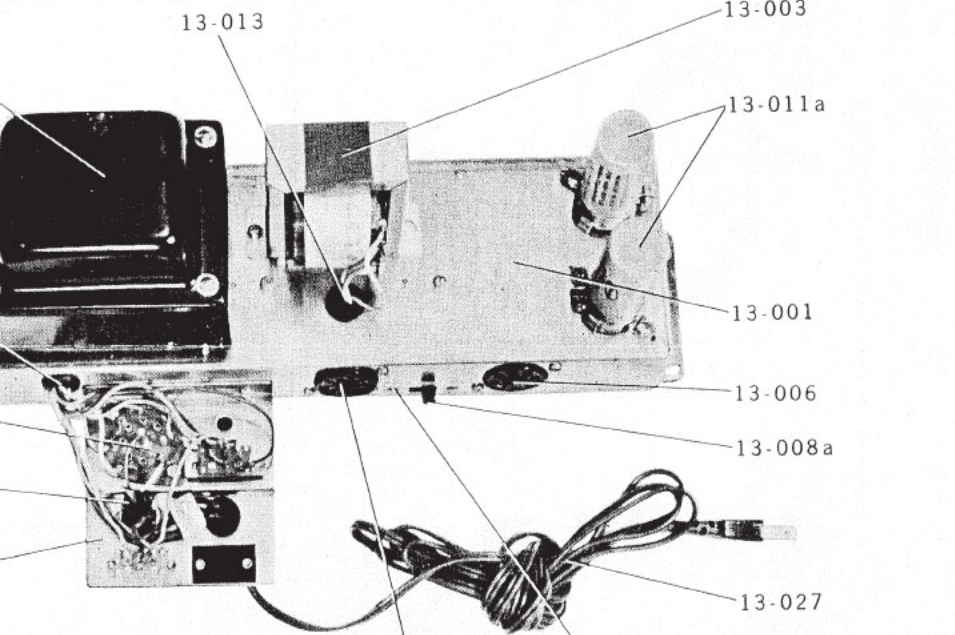

Power Block II

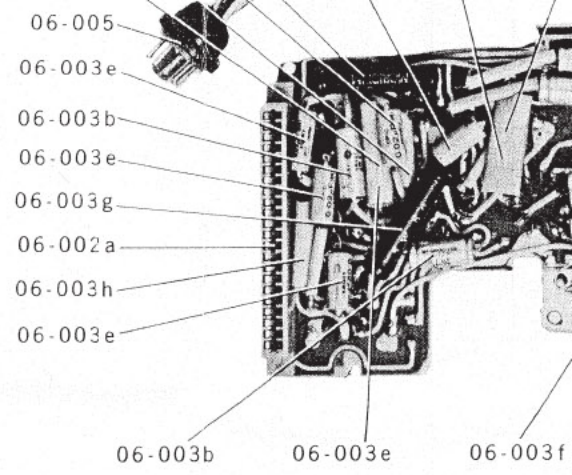
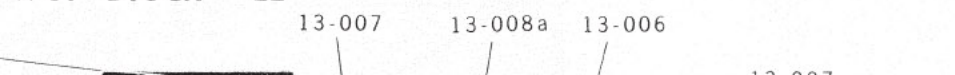

Amplifier I

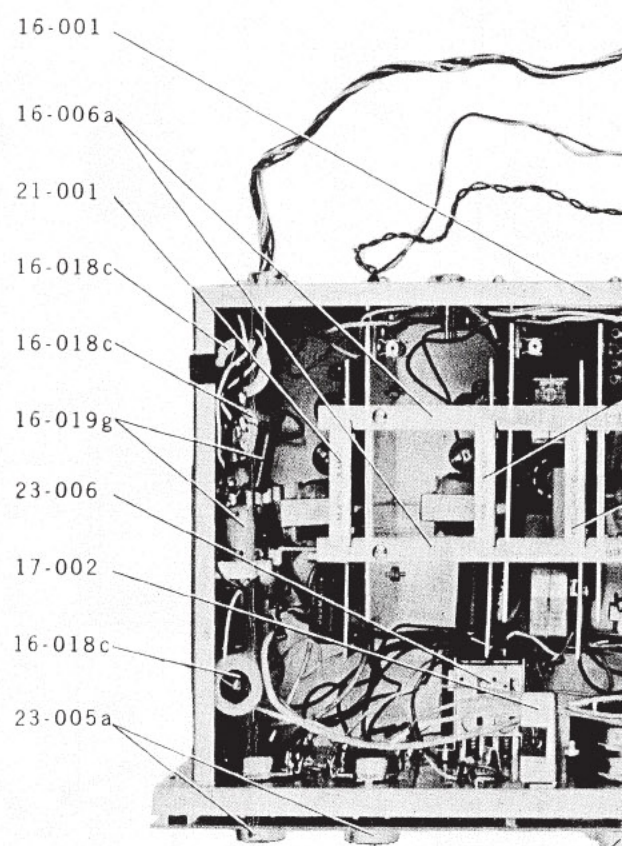

Amplifier II

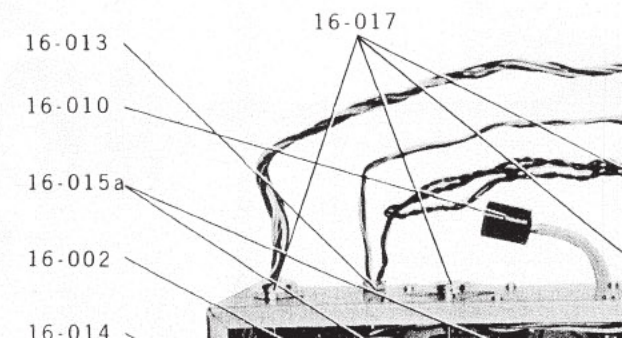

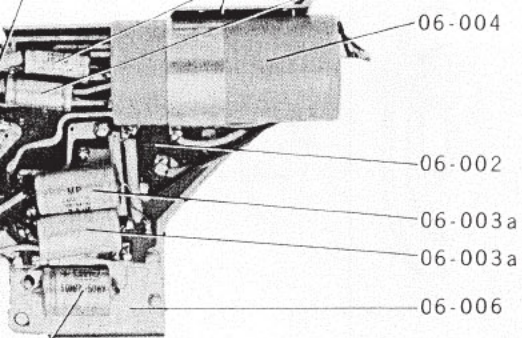

06-004
06-002
06-003a
06-003a
06-006

03f

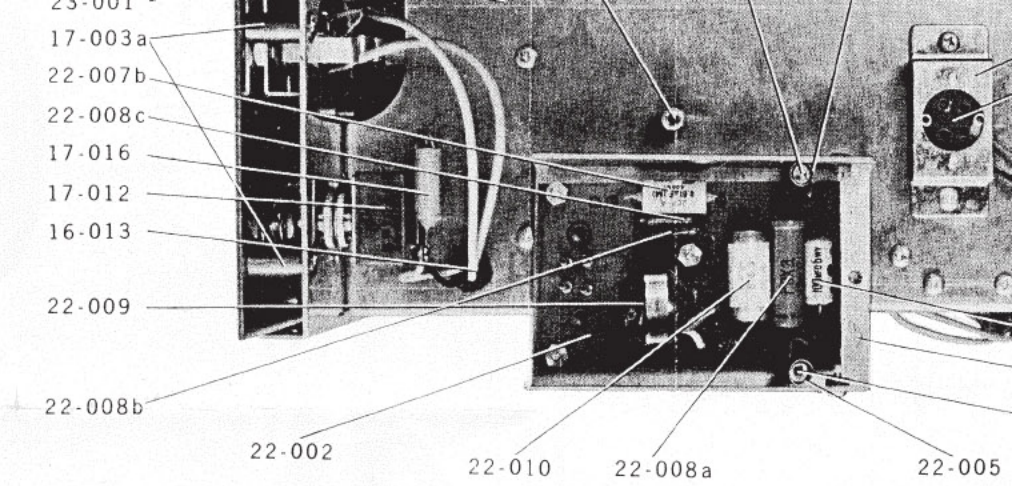

23-001
17-003a
22-007b
22-008c
17-016
17-012
16-013
22-009
22-008b

22-002
22-010
22-008a
22-005

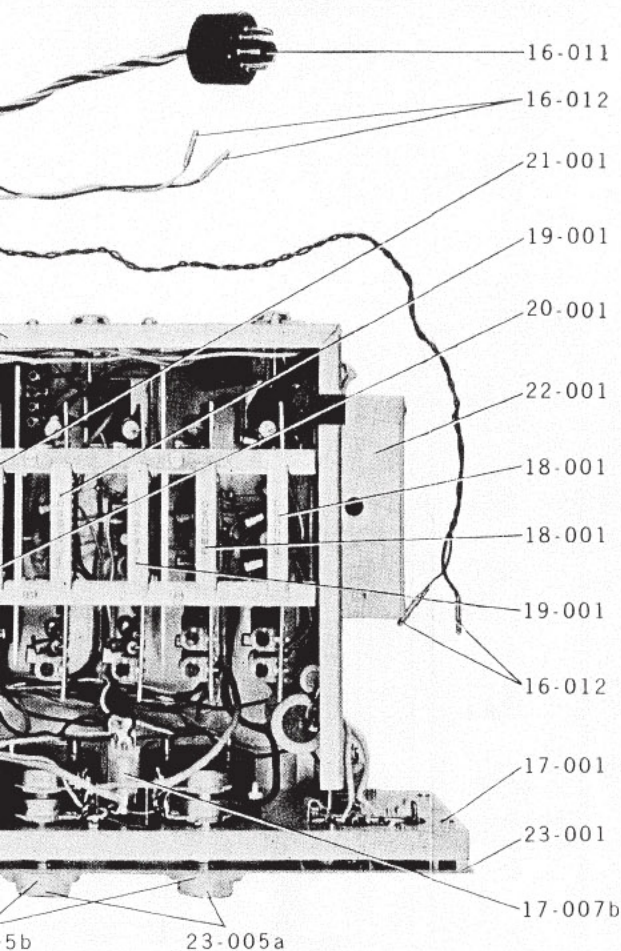

16-011
16-012
21-001
19-001
20-001
22-001
18-001
18-001
19-001
16-012

5b

23-005a

17-001
23-001
17-007b

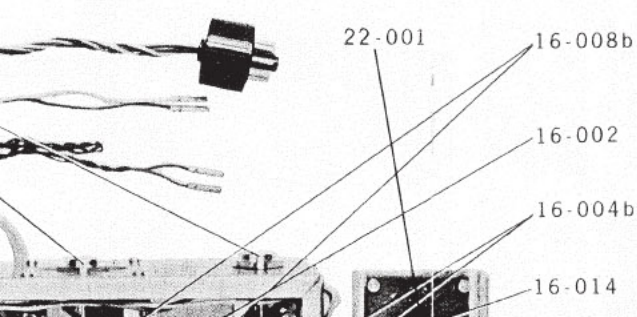

22-001
16-008b
16-002
16-004b
16-014

Amplifier IV

RELAY BLOCK

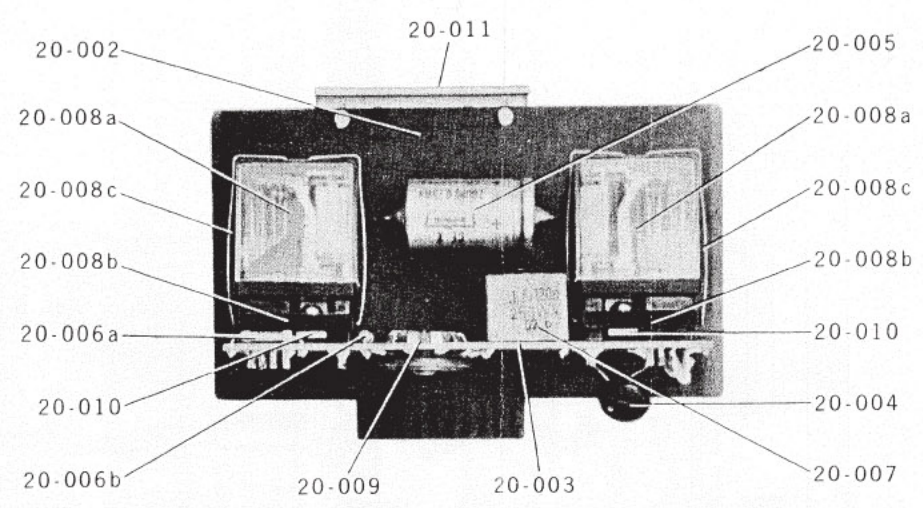

20-002
20-008a
20-008c
20-008b
20-006a
20-010
20-006b

20-011

20-005
20-008a
20-008c
20-008b
20-010
20-004
20-007

20-009
20-003

PLAYBACK

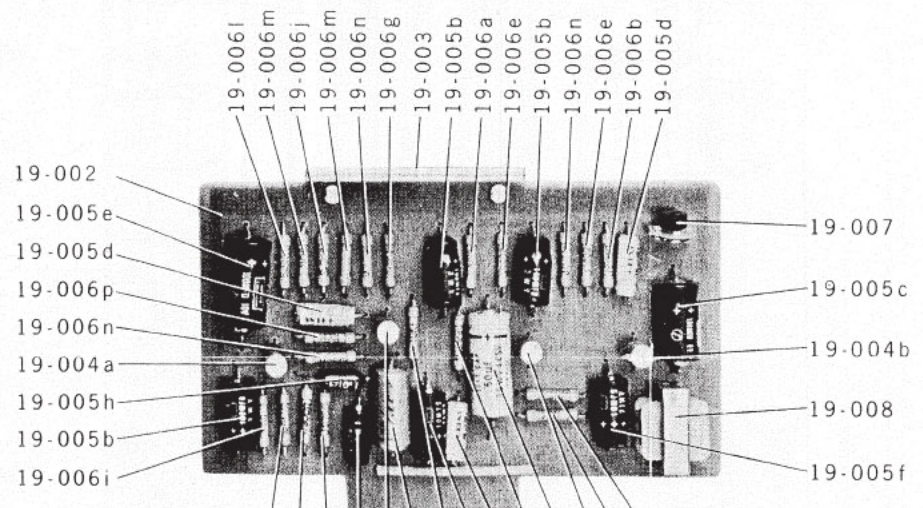

19-002
19-005e
19-005d
19-006p
19-006n
19-004a
19-005h
19-005b
19-006i

19-006l
19-006m
19-006j
19-006m
19-006n
19-006g
19-003
19-005b
19-006a
19-006e
19-005b
19-006n
19-006e
19-006b
19-005d
19-006f
19-006o

19-007
19-005c
19-004b
19-008
19-005f

Amplifier V

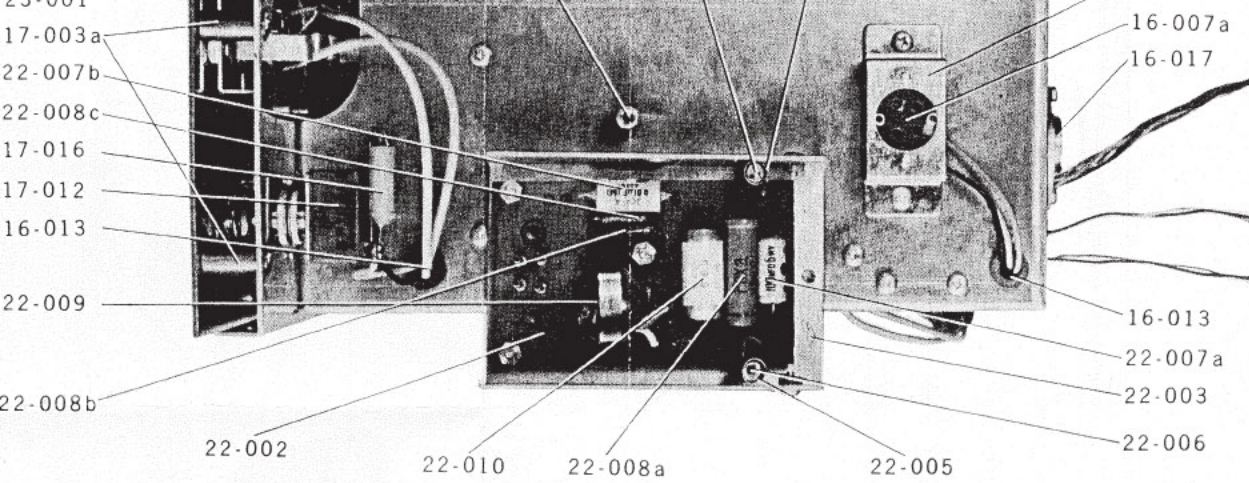

Amplifier IV

RELAY BLOCK

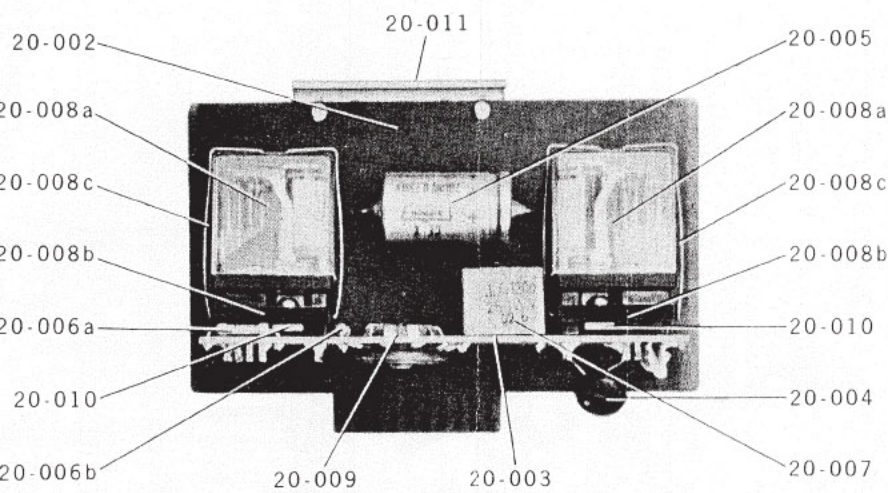

MAIN AMP. BLOCK

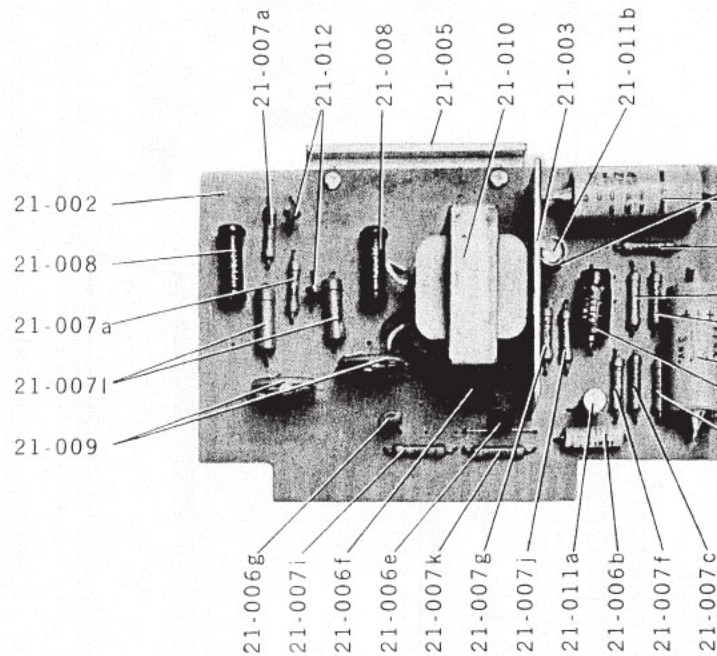

PLAYBACK

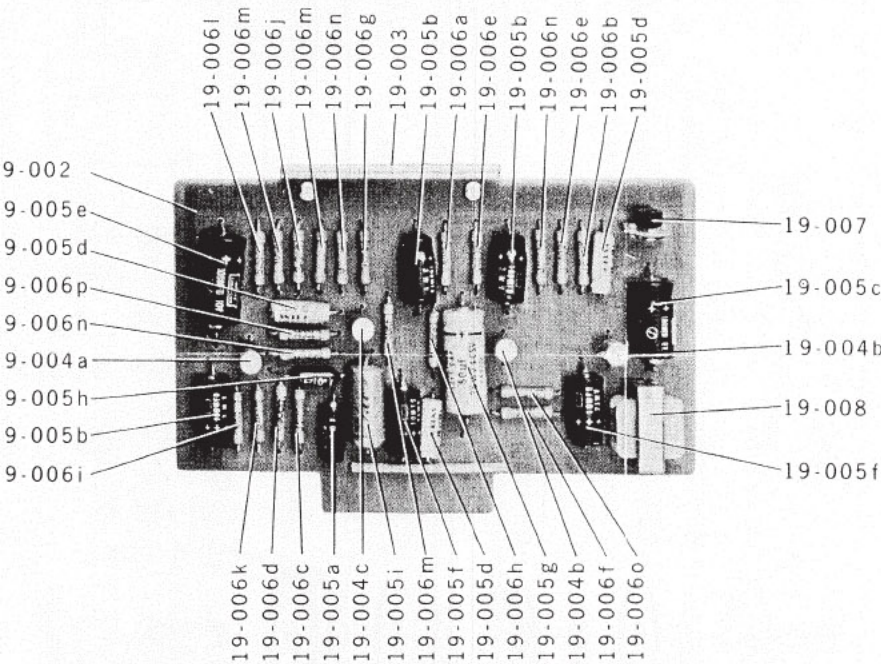

RECORD

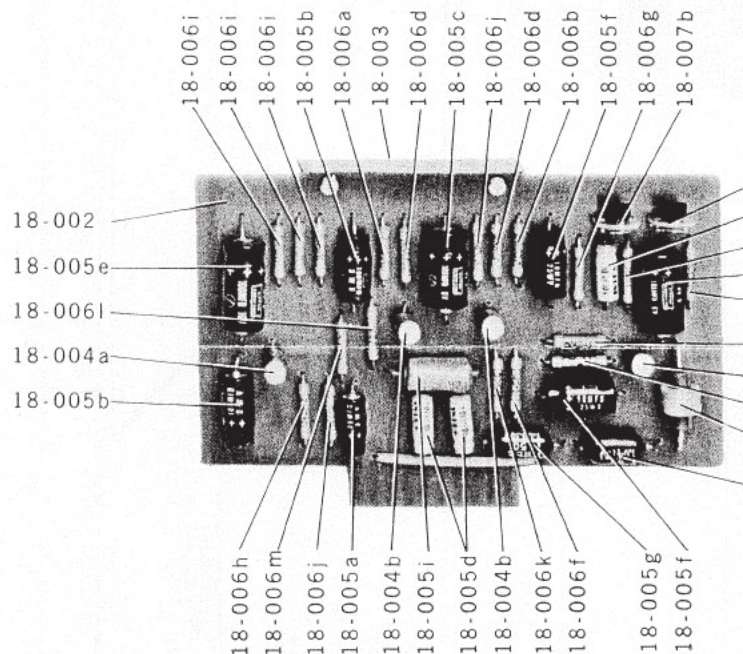

Amplifier V

