

ALESIS

MultiMix 16 USB (XU7)

Service Manual

P/N: 8-31-0157-A

ATTENTION!

THIS DOCUMENT CONTAINS SENSITIVE
PROPRIETARY INFORMATION.
ALL RECIPIENTS MUST HAVE A CURRENT
NON-DISCLOSURE AGREEMENT ON FILE
WITH ALESIS, LLC.

**DO NOT MAKE ILLEGAL
COPIES OF THIS DOCUMENT**

The information in this document contains privileged and confidential information. It is intended only for the use of those authorized by Alesis. If you are not the authorized, intended recipient, you are hereby notified that any review, dissemination, distribution or duplication of this document is strictly prohibited. If you are not authorized, please contact Alesis and destroy all copies of this document. You may contact Alesis at servicemanuals@alesis.com or at support@alesis.com.

Copyright Alesis, LLC

Preface

This document is intended to assist the service technician in the operation, maintenance and repair of the Alesis device. Together with the User Reference Manual, this document provides a complete description of the functionality and serviceability of the Device. Any comments or suggestions you may have pertaining to the document are welcome and encouraged.

READ THIS!

In addition to any purchase price that Alesis may charge as consideration for Alesis selling or otherwise transferring this service manual ("Manual") to you, if you are not a service and repair facility ("Service Center") authorized by Alesis in writing to be an authorized Service Center, Alesis sells or transfers the Manual to you on the following terms and conditions:

Only Service Centers authorized by Alesis in writing are authorized to perform service and repairs covered by an Alesis warranty (if any), and transfer of the Manual to you does not authorize you to be an authorized Service Center. **Therefore, if you perform, or if the Manual is used to perform, any service or repairs on any Alesis product or part thereof, any and all warranties of Alesis as to that product and any service contract with Alesis for that product shall be voided and shall no longer apply for such product, even if your services or repairs were done in accordance with the Manual.**

All service or repairs done by you or with reference to the Manual shall be solely your responsibility, and Alesis shall have no liability for any such repairs or service work. **All such service or repairs are performed at the sole risk of the person performing the service or repairs.** You agree that all such work will be performed in a competent, professional and safe manner at all times and to indemnify and fully hold Alesis and its successors and assigns harmless in the event of any failure to so perform.

Your purchase of the Manual shall be for your own ultimate use and shall not be for purposes of resale or other transfer.

As the owner of the copyright to the Manual, Alesis does not give you the right to copy the Manual, and you agree not to copy the Manual without the written authorization of Alesis. Alesis has no obligation to provide to you any correction of, or supplement to, the Manual, or any new or superseding version thereof.

Alesis shall have the right to refuse to sell or otherwise transfer repair parts or materials to you in its sole discretion. You shall not use, sell or otherwise transfer spare or replacement parts supplied by Alesis to you (i) to repair or be used in products manufactured for or by third parties or (ii) to any third parties for any purpose.

You shall not make any warranties or guarantees with respect to the products of Alesis or the use thereof on behalf of Alesis or in your own name.

The foregoing describes the entire understanding related to sale or transfer of the Manual to you, and no other terms shall apply unless in a writing signed by an authorized representative of Alesis.

All Trademarks are property of their respective companies.

Warnings

TO REDUCE THE RISK OF ELECTRIC SHOCK OR FIRE, DO NOT EXPOSE THIS PRODUCT TO WATER OR MOISTURE.



The arrowhead symbol on a lightning flash inside a triangle is intended to alert the user to the presence of un-insulated "dangerous voltage" within the enclosed product which may be of sufficient magnitude to constitute a risk of electric shock to persons.



The exclamation point inside a triangle is intended to alert the user to the presence of important operating, maintenance and servicing instructions in the literature which accompanies the product.

REPAIR BY ANY PERSON OR ENTITY OTHER THAN AN AUTHORIZED ALESIS SERVICE CENTER WILL VOID THE ALESIS WARRANTY.

PROVISION OF THIS MANUAL DOES NOT AUTHORIZE THE RECIPIENT TO COMPETE WITH ANY ALESIS DISTRIBUTOR OR AUTHORIZED REPAIR SERVICE CENTER IN THE PROVISION OF REPAIR SERVICES OR TO BE OR MAKE REPAIRS AS AN AUTHORIZED SERVICE CENTER.

ALL REPAIRS DONE BY ANY ENTITY OTHER THAN AN AUTHORIZED ALESIS SERVICE CENTER SHALL BE SOLELY THE RESPONSIBILITY OF THAT ENTITY, AND ALESIS SHALL HAVE NO LIABILITY TO THAT ENTITY OR TO ANY OTHER PARTY FOR ANY REPAIRS BY THAT ENTITY.

Regarding the Power Supply Fuse



CAUTION: The product under service may employ the use of a replaceable fuse. Danger of fire or electrocution if fuse is incorrectly replaced. Replace with only the same type or equivalent type recommended by the equipment manufacturer.

Regarding the Internal Battery



CAUTION: The product under service may employ the use of an internal battery. Danger of explosion if battery is incorrectly replaced. Replace only with the same or equivalent type recommended by the manufacturer. Dispose of used batteries according to the manufacturer's instruction.

Safety Instructions

Carefully read the applicable items of the operating instructions and these safety suggestions before using this product. Use extra care to follow the warnings written on the product itself and in the operating instructions. Keep the operating instructions and safety suggestions for reference in the future.

1. Power Source. The product should only be connected to a power supply which is described either in the operating instructions or in markings on the product.
2. Power Cord Protection. AC power supply cords should be placed such that no one is likely to step on the cords and such that nothing will be placed on or against them.
3. Periods of Non-use. If the product is not used for any significant period of time, the product's AC power supply cord should be unplugged from the AC outlet.
4. Foreign Objects and Liquids. Take care not to allow liquids to spill or objects to fall into any openings of the product.
5. Water or Moisture. The product should not be used near any water or in moisture.
6. Heat. Do not place the product near heat sources such as stoves, heat registers, radiators or other heat producing equipment.
7. Ventilation. When installing the product, make sure that the product has adequate ventilation. Improperly ventilating the product may cause overheating, which may damage the product.
8. Mounting. The product should only be used with a rack which the manufacturer recommends. The combination of the product and rack should be moved carefully. Quick movements, excessive force or uneven surfaces may overturn the combination which may damage the product and rack combination.
9. Cleaning. The product should only be cleaned as the manufacturer recommends.
10. Service. The user should only attempt the limited service or upkeep specifically described in the operating instructions for the user. For any other service required, the product should be taken to an authorized service center as described in the operating instructions.
11. Damage to the Product. Qualified service personnel should service the unit in certain situations including without limitation when:
 - a. Liquid has spilled or objects have fallen into the product,
 - b. The product is exposed to water or excessive moisture,
 - c. The AC power supply plug or cord is damaged,
 - d. The product shows an inappropriate change in performance or does not operate normally, or
 - e. The enclosure of the product has been damaged.

SERVICE MANUAL

MODEL: MULTIMIX 16USB

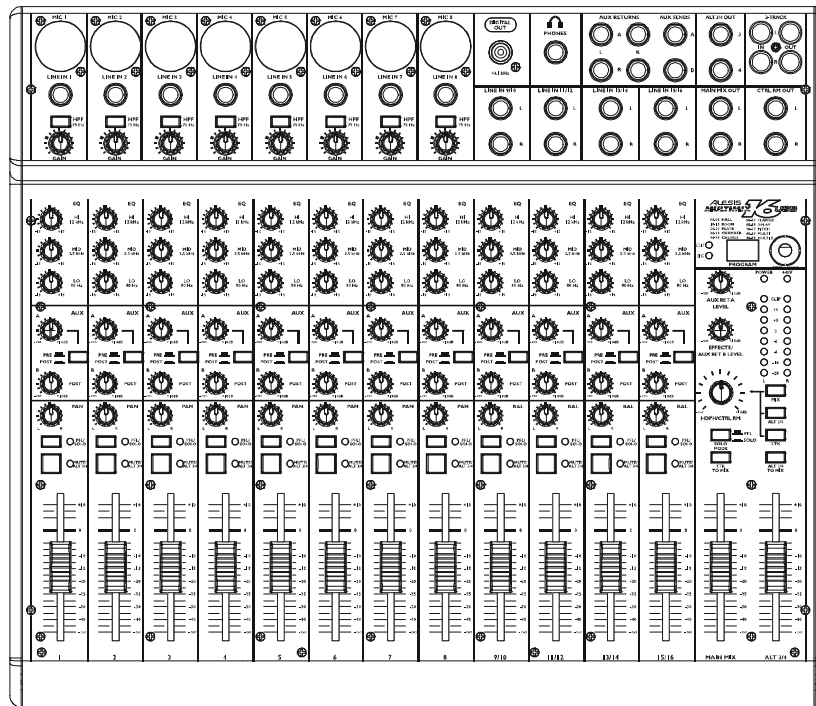

Multimix 16 USB Key Features

Three Models:

Multimix 16 USB (8 mic/line preamps, 4 stereo inputs)

Clean and powerful preamps – up to 50dB of preamp gain for capturing quiet sources. Globally switched phantom power.

4 Stereo inputs – Great for line-level instruments.

Internal digital effects processor with 100 preset effects and an easy-to-read display – includes a variety of reverbs, delays, choruses, flanges, a pitch transposer and multiple combinations of these.

3-band EQ per channel – a potent tool for sonically shaping each channel to get that perfect mix.

1 pre/post-fader aux send per channel (switchable) – gives you control over the level of the pre- or post-fader signal being routed to an external device.

1 post-fader aux send/effects send per channel – a control for the signal being routed to another external device or to the onboard effects processor.

Control room output level – provides control over the separate control room output

2-track send and return – lets you mix your audio to tape or other media and to add a tape deck or CD player to the mix.

Stereo USB input and output – routes the main output and the 2-track return through the USB port in crystal-

clean, 16-bit, 44.1 kHz stereo digital audio. Use the Multimix USB as a high-quality soundcard for recording and playback with Windows and Macintosh computers.

Specifications

For the more technical-minded, here are some detailed specifications for the MultiMix's operating levels.

Input Channels

Mic In Sensitivity Range: -60dBu to -10dBu nominal, +5dBu Maximum

Line In Sensitivity Range: -40dBu to +10dBu nominal, +25dBu maximum

Mic/Line Gain Range: +10 to +60dB

Equalization

High-Pass Filter: 75Hz, 18dB/octave

High Shelving: 12kHz, +/- 15dB

Mid Bandpass/Band Reject: 2.5 kHz, +/- 15dB

Low Shelving: 80Hz, +/- 15dB

Aux Sends

Aux Send A & B Gain Range: - to +10dB

Aux Returns

Aux Return A Gain Range: - to +15dB

Effects Level/

Aux Return B Gain Range: - to +15dB

Channel Levels

Channel Level Gain Range: - to +10dB

Master Levels

Main Mix, Ctrl Room Gain

Range: - to +10dB

1/4" Inputs

Stereo Aux Return Level: +4dBu nominal, +20dBu maximum

RCA Inputs

Tape In Level: -10dBV nominal, +5dBV maximum

1/4" Outputs

Main Mix, Ctrl Room,

Aux 3/4, Ext Aux

Send Level: +4dBu nominal, +20dBu maximum

Headphone Output: 75 ohm output impedance
>105mW into 75 ohms, >40mW
into 600ohms

RCA Outputs

Tape Out Level: -10dBV nominal, +5dBV maximum

PACKING DIAGRAM

(US/EU/UK/AUS NZ)

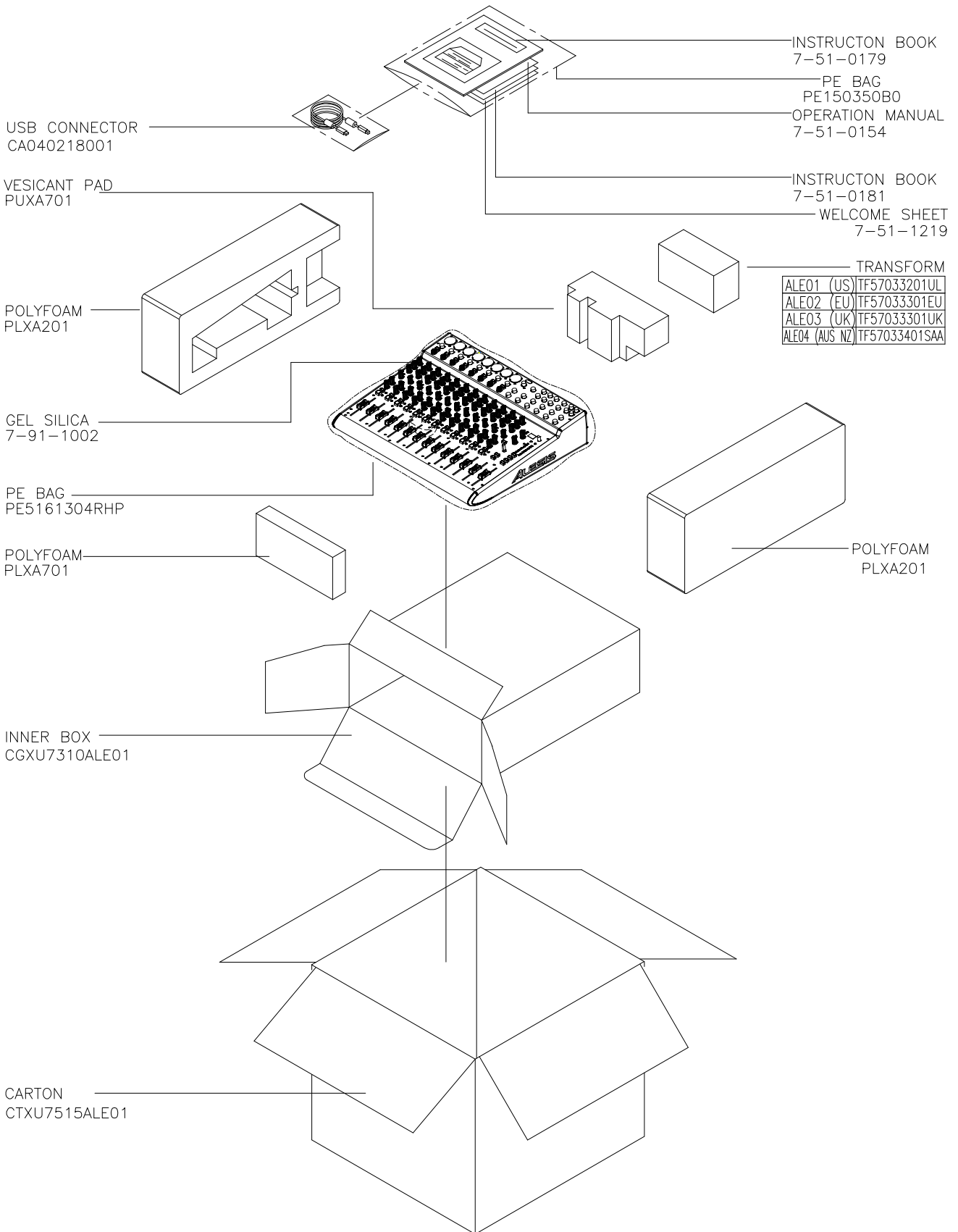

ALESIS

MultiMix 16 USB (XU7)

SCHEMATIC AND PCB FILES

DISASSEMBLY PROCEDURES

1. REMOVAL OF TOP PANEL/BOTTOM PANEL (Fig.1)

(A) TAKE OUT THE 14 PCS SCREW FROM WHICH THE TOP PANEL

(B) TAKE OUT THE 10 PCS SCREW FROM WHICH THE BOTTOM PANEL

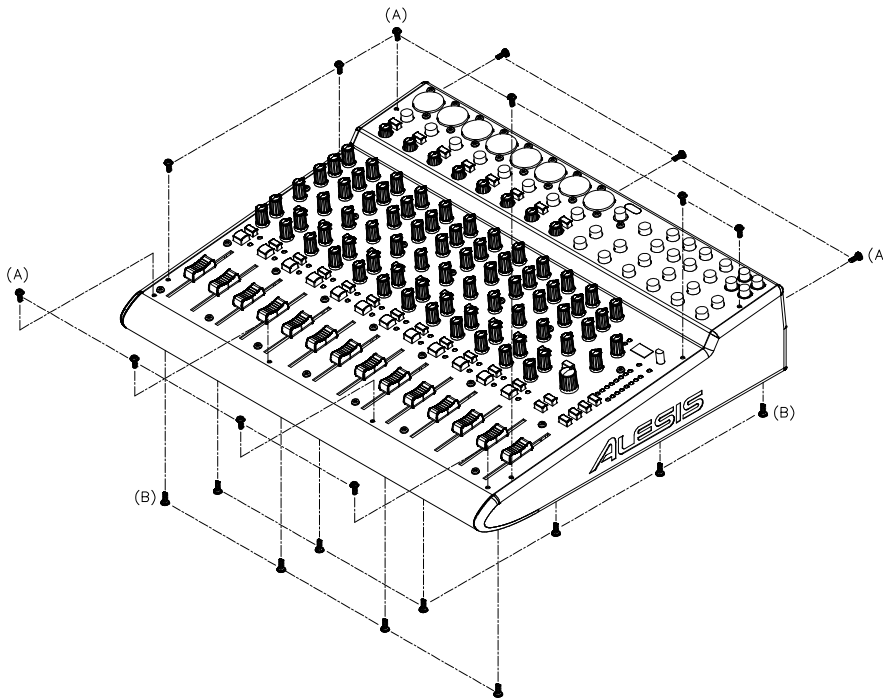

(Fig.1)

2. REMOVAL OF MAIN P.C.B (Fig.2)

(A) REMOVE THE 89 PCS KNOB FROM WHICH THE TOP PANEL

(B) REMOVE THE 54 PCS NUT AND 25 PCS WASHER FROM WHICH THE TOP PANEL

(C) REMOVE THE 24 PCS SCREW FROM WHICH THE TOP PANEL

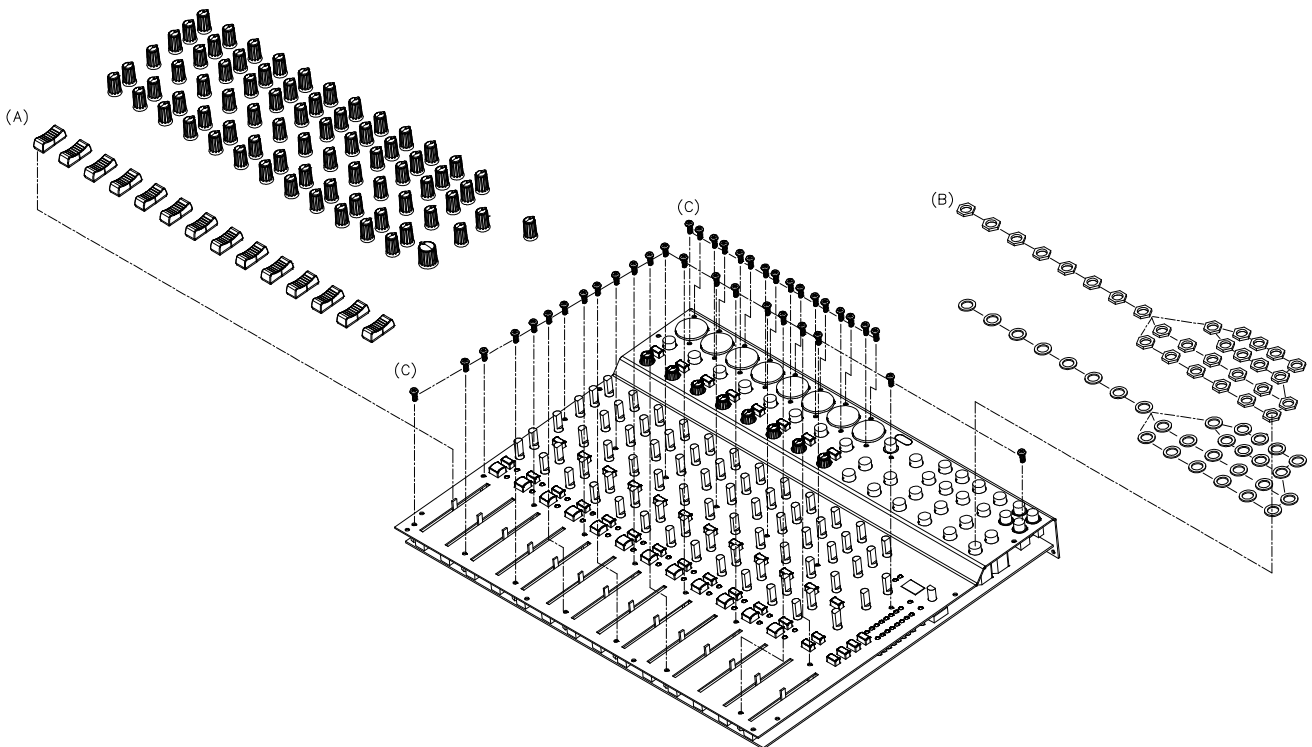

(Fig.2)

3. REMOVAL OF POWER P.C.B (Fig.3)

- (A) REMOVE THE 2 PCS SCREW FROM THE POWER P.C.B
- (B) REMOVE THE 2 PCS SCREW FROM THE BRACKET
- (C) REMOVE THE 3 PCS OF CABLE CONNECTOR FROM THE POWER P.C.B
- (D) REMOVE THE 2 PCS SCREW FROM THE USB P.C.B

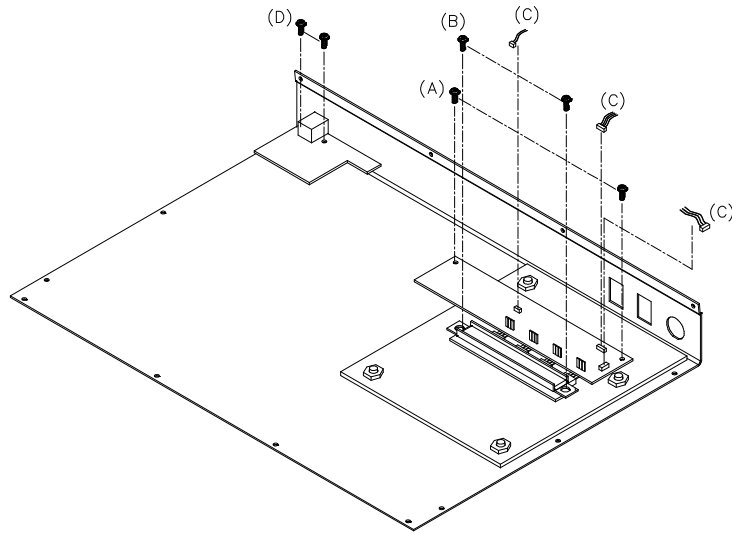

(Fig.3)

WIRING DIAGRAM

(US/EU/UK/AUS NZ)

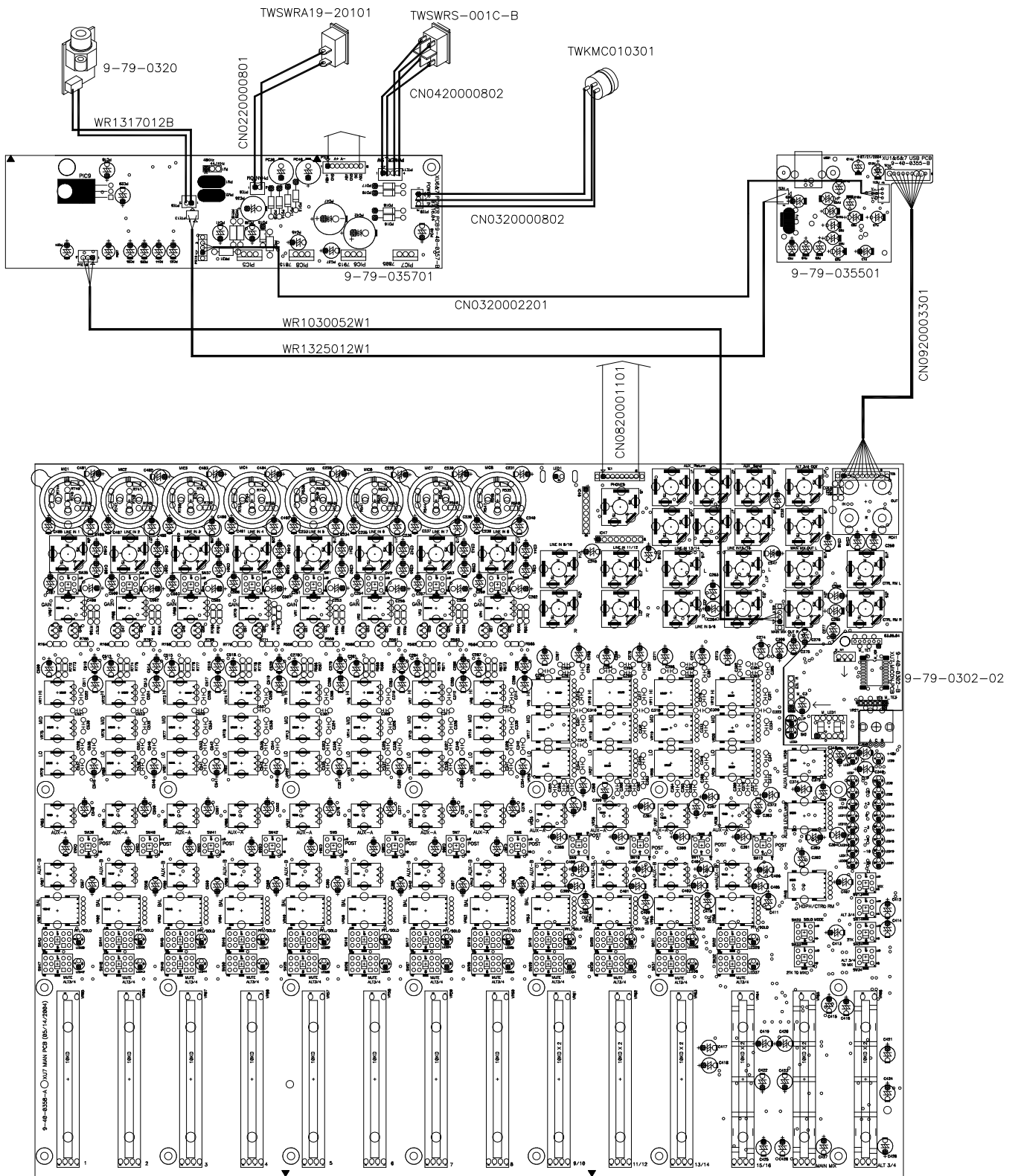

EXPLODE DIAGRAM

(US/EU/UK/AUS NZ)

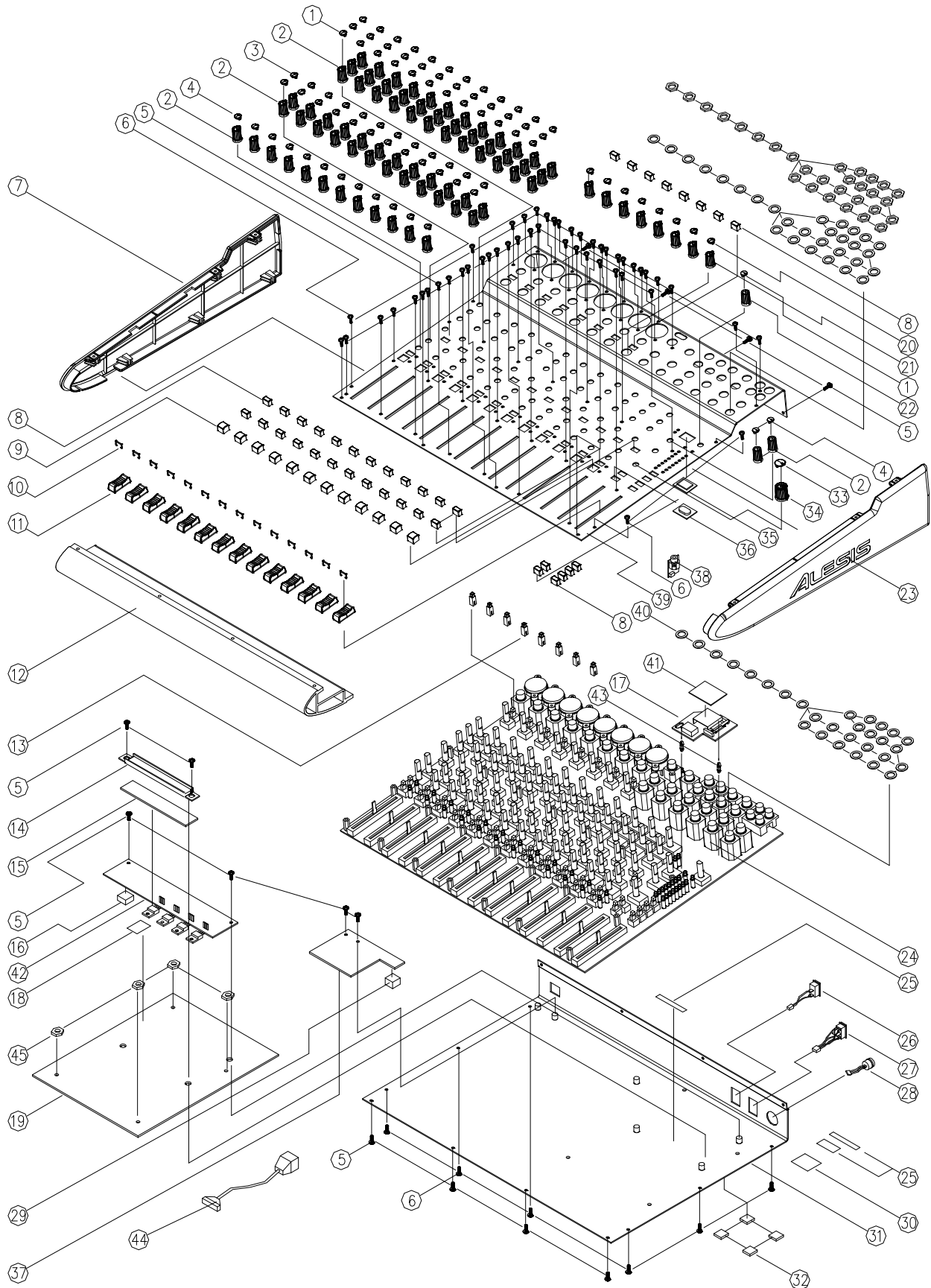

SEQUENTIAL NO OF EXPLODE DIAGRAM WILL BE MARKED ON REF. COLUMNM OF BOM LIST

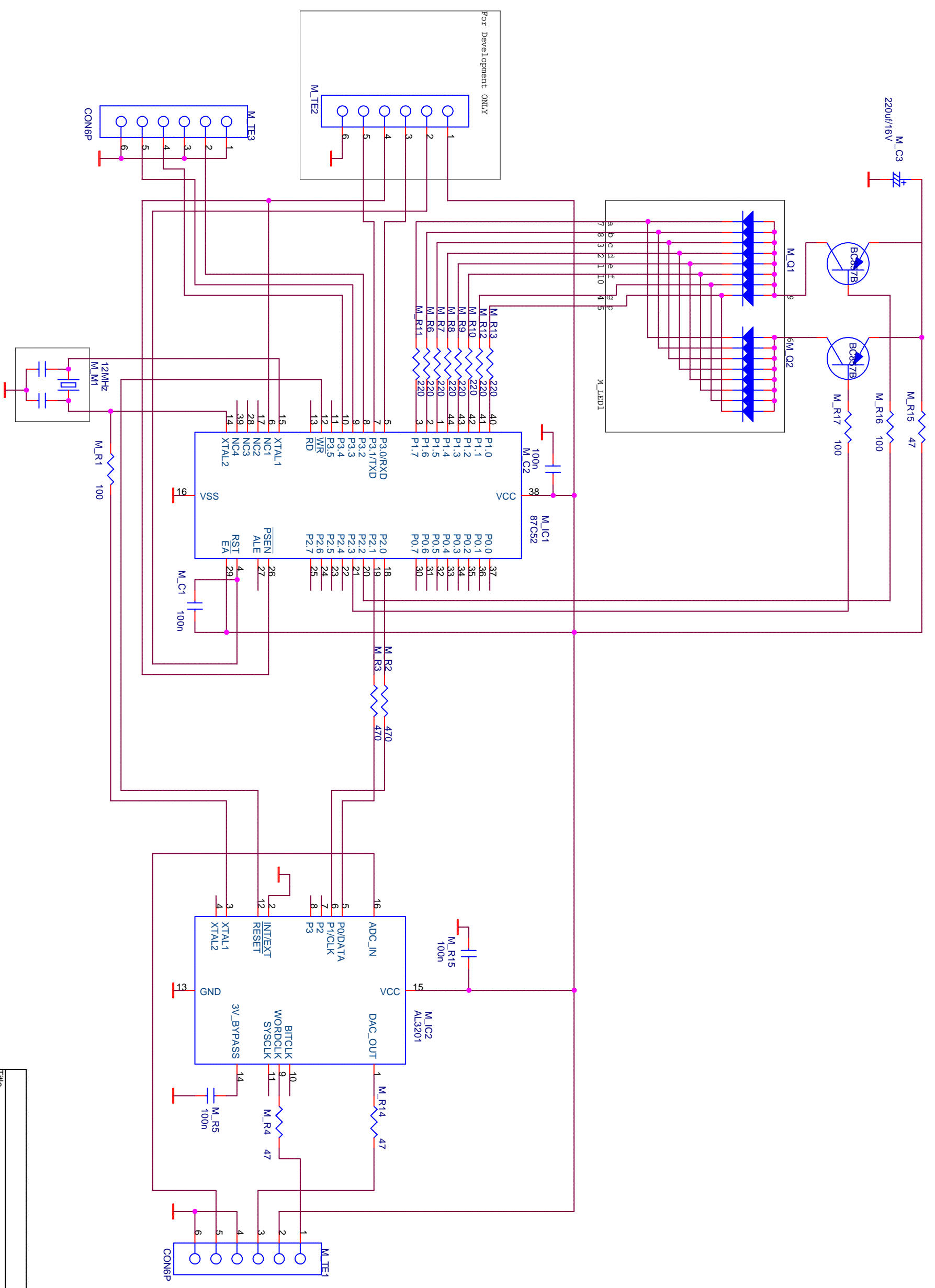

Title		MICON_DSP for XAXU SERIES	
Size	Document Number	XAXXAXMICON	
A3	Rev	PP	
Date:	Tuesday, September 16, 2003	Sheet	3 of 3

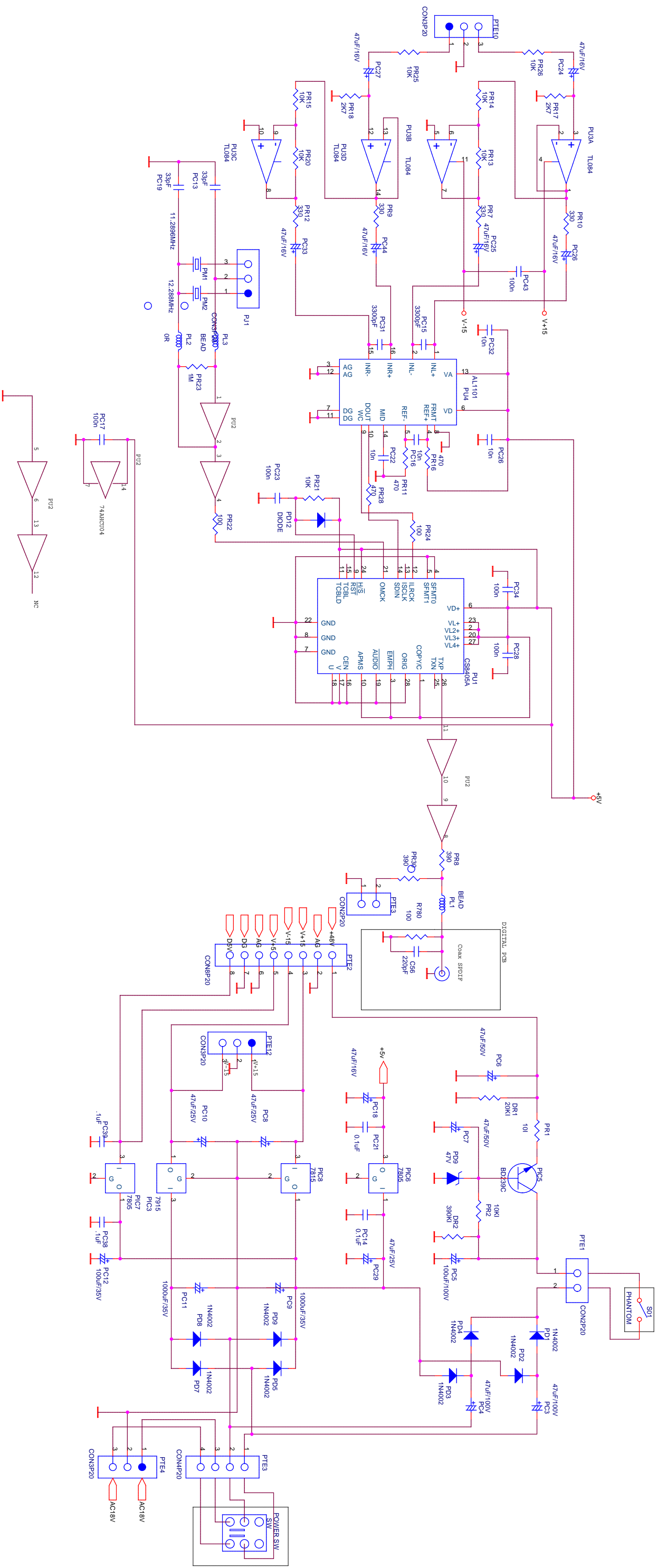

Title	Digital Out for XLR/UD7
Document Number	XLR/UD6 POWER
Size	A2
Date:	Monday, August 30, 2004
Sheet	1 of 0
Rev	

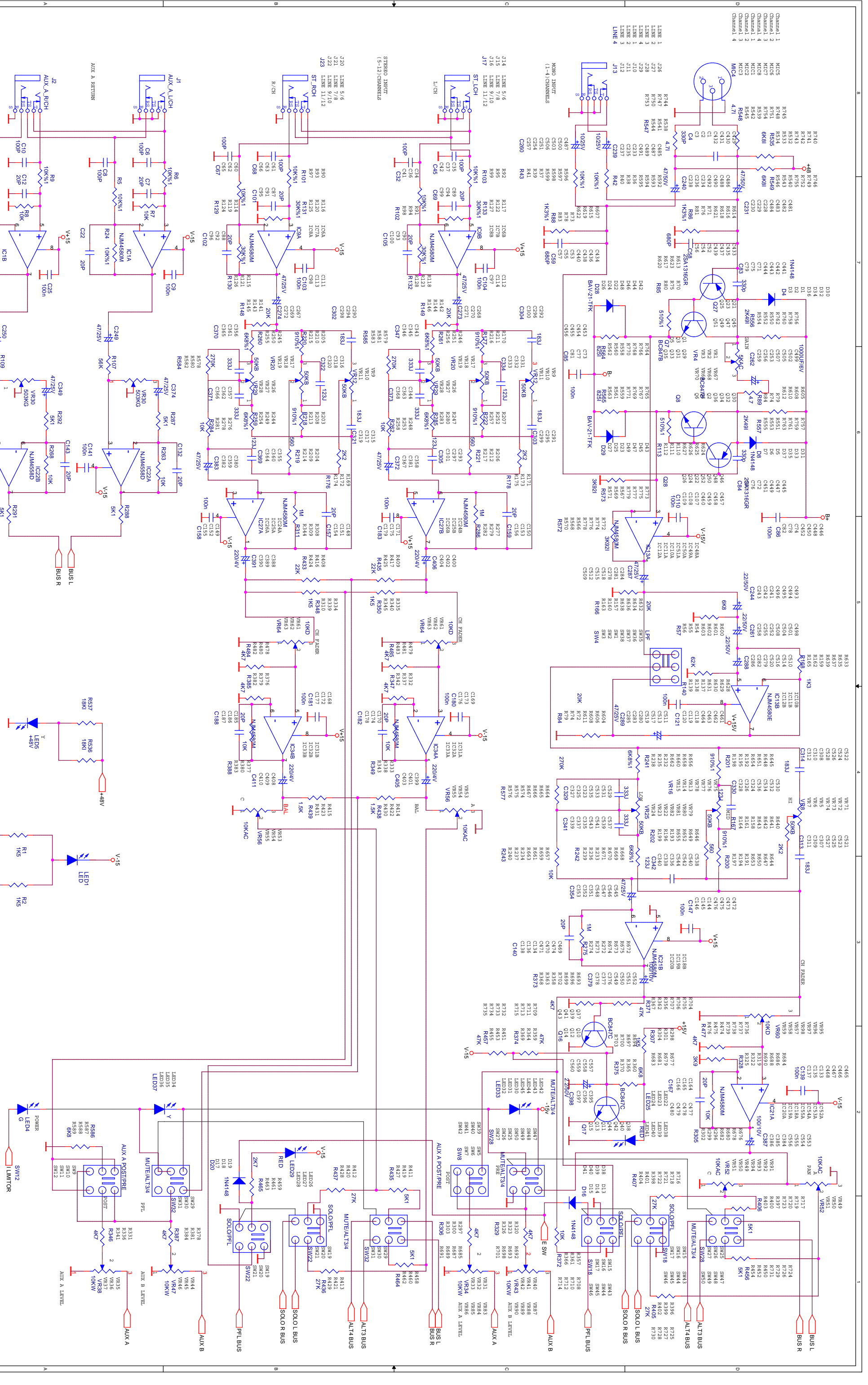

YH THORNS ELECTRONIC CO., LTD.

Title	Document Number	Rev
XLR INPUT CIRCUIT DIAGRAM	XU/YX/UT/INI-SCH	PP

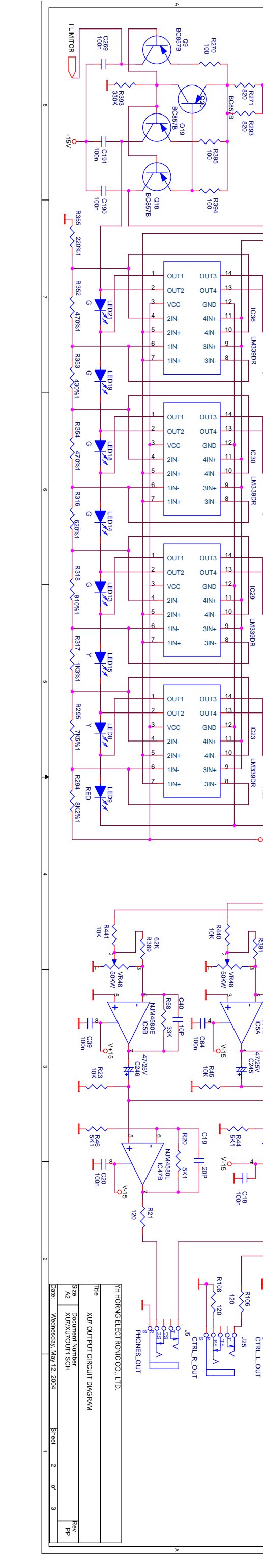
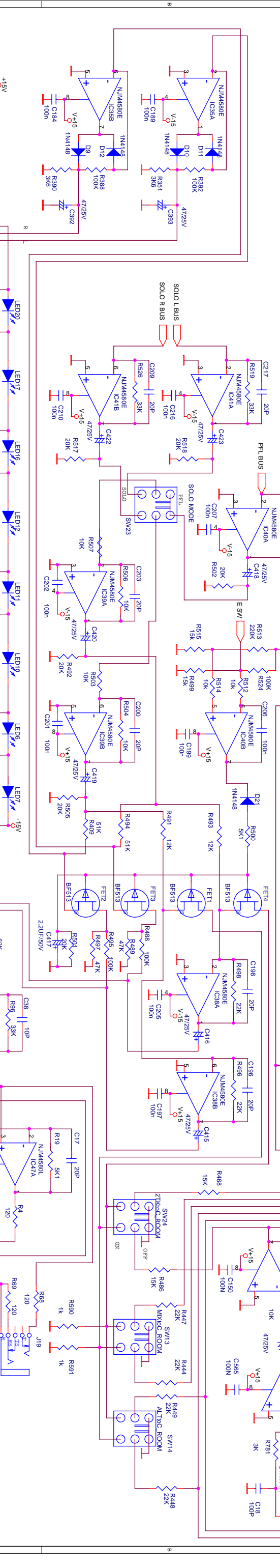
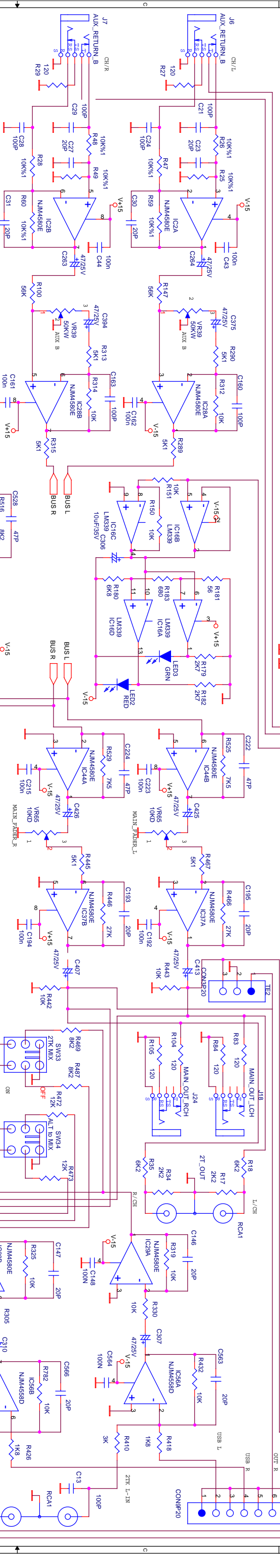
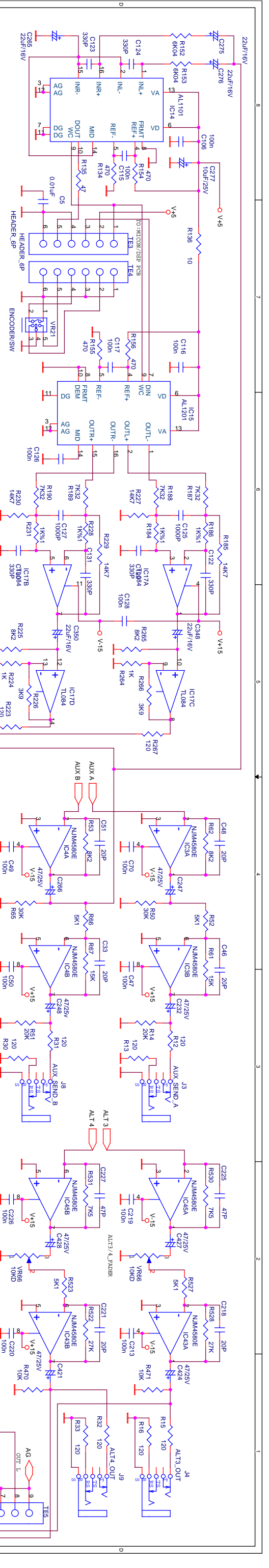

YH HORNUNG ELECTRONIC CO., LTD.	
Title	XLR OUTPUT CIRCUIT DIAGRAM
Size	Document Number
A2	XLR/OUTPUT.SCH
Date:	Wednesday, May 12, 2004
Sheet	1 of 3
Rev	PP

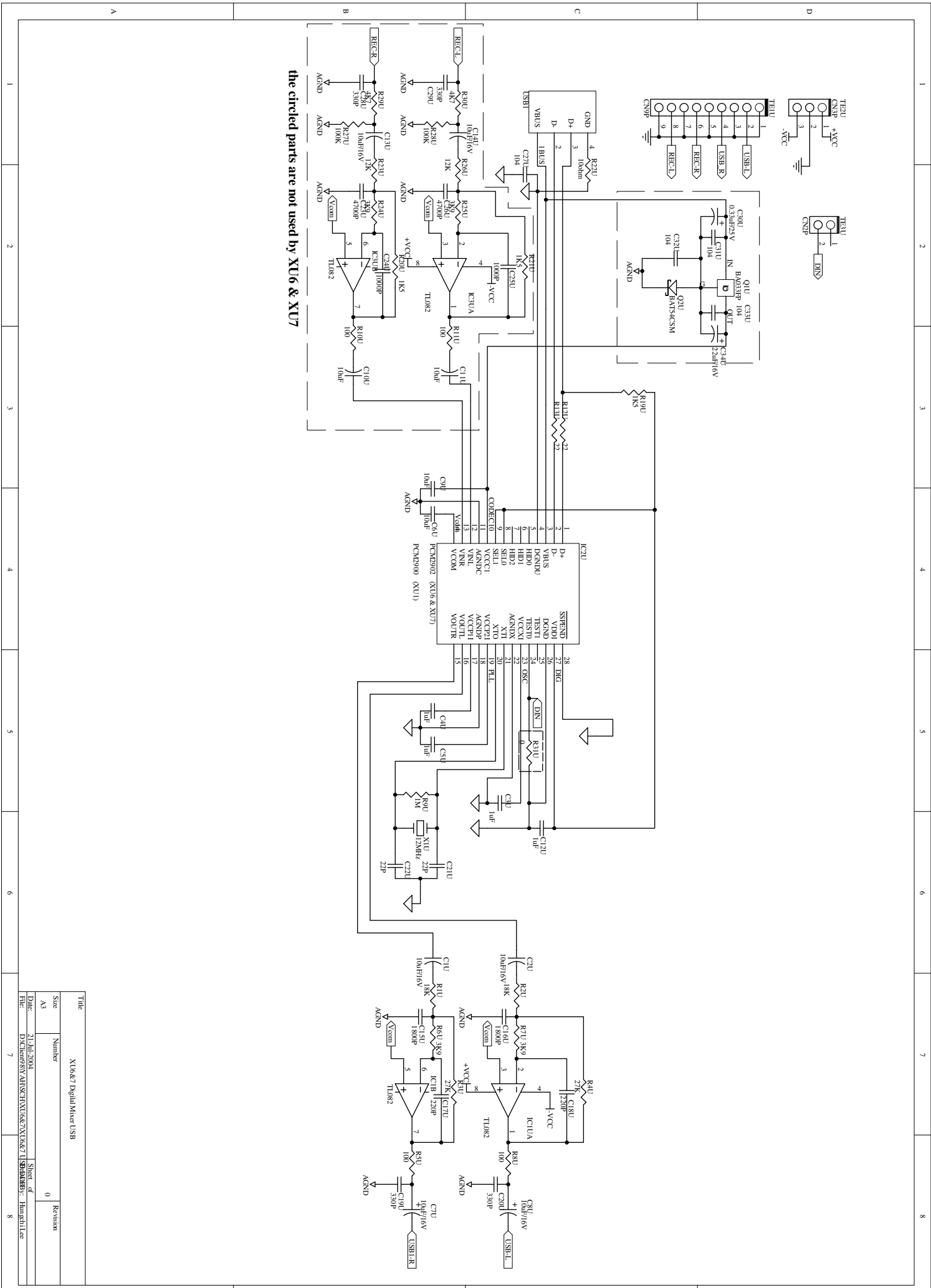

the circled parts are not used by XU6 & XU7

Title		XU6&7 Digital Mixer USB	
Size	Number	Revision	0
A3			
Date	21 Jul 2004	Sheet of	1
File	D:\Component\AV\SH\XU6&7\XU6&7_USB\00000000.DWG	Drawn by	lhongshilice

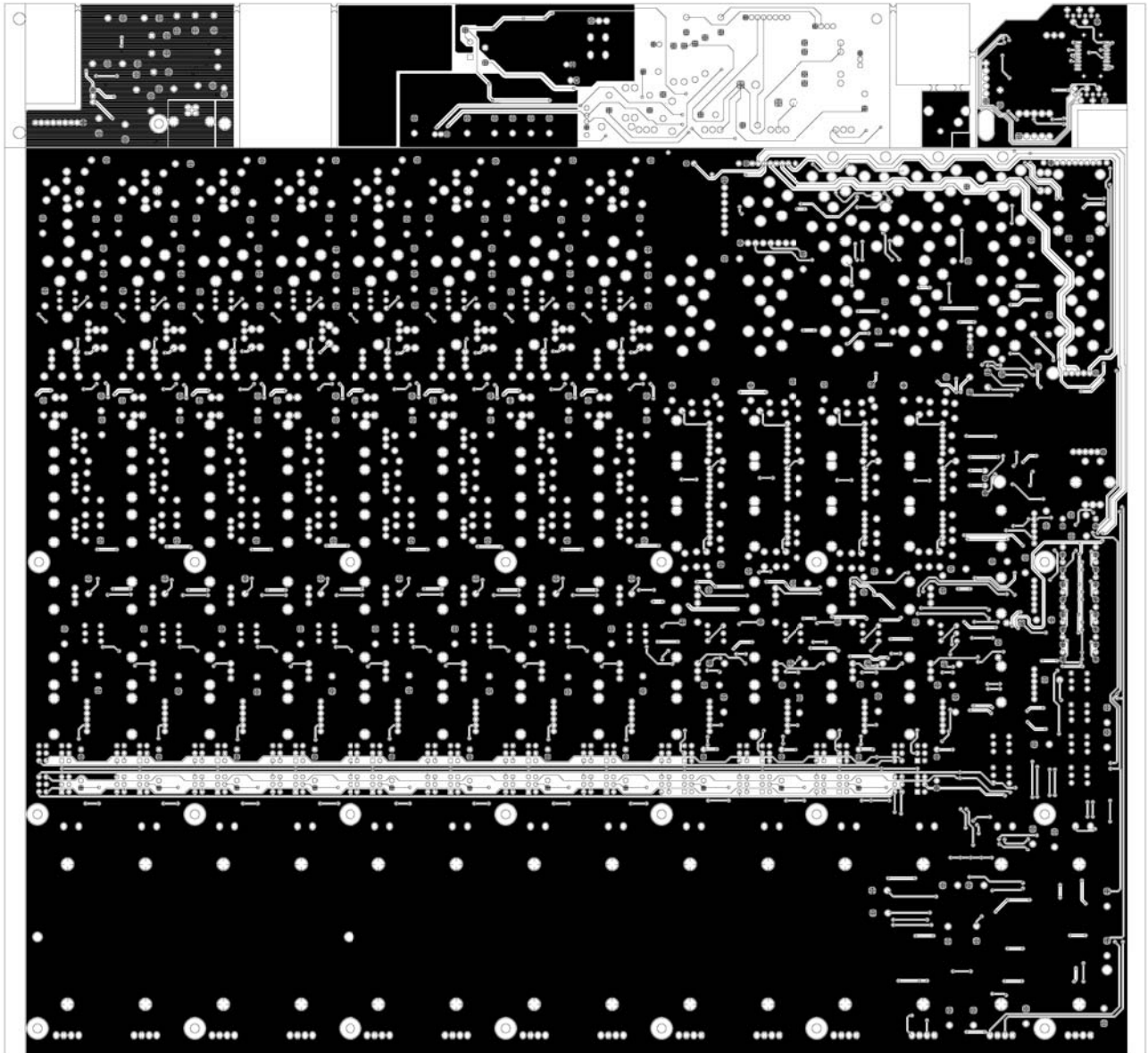

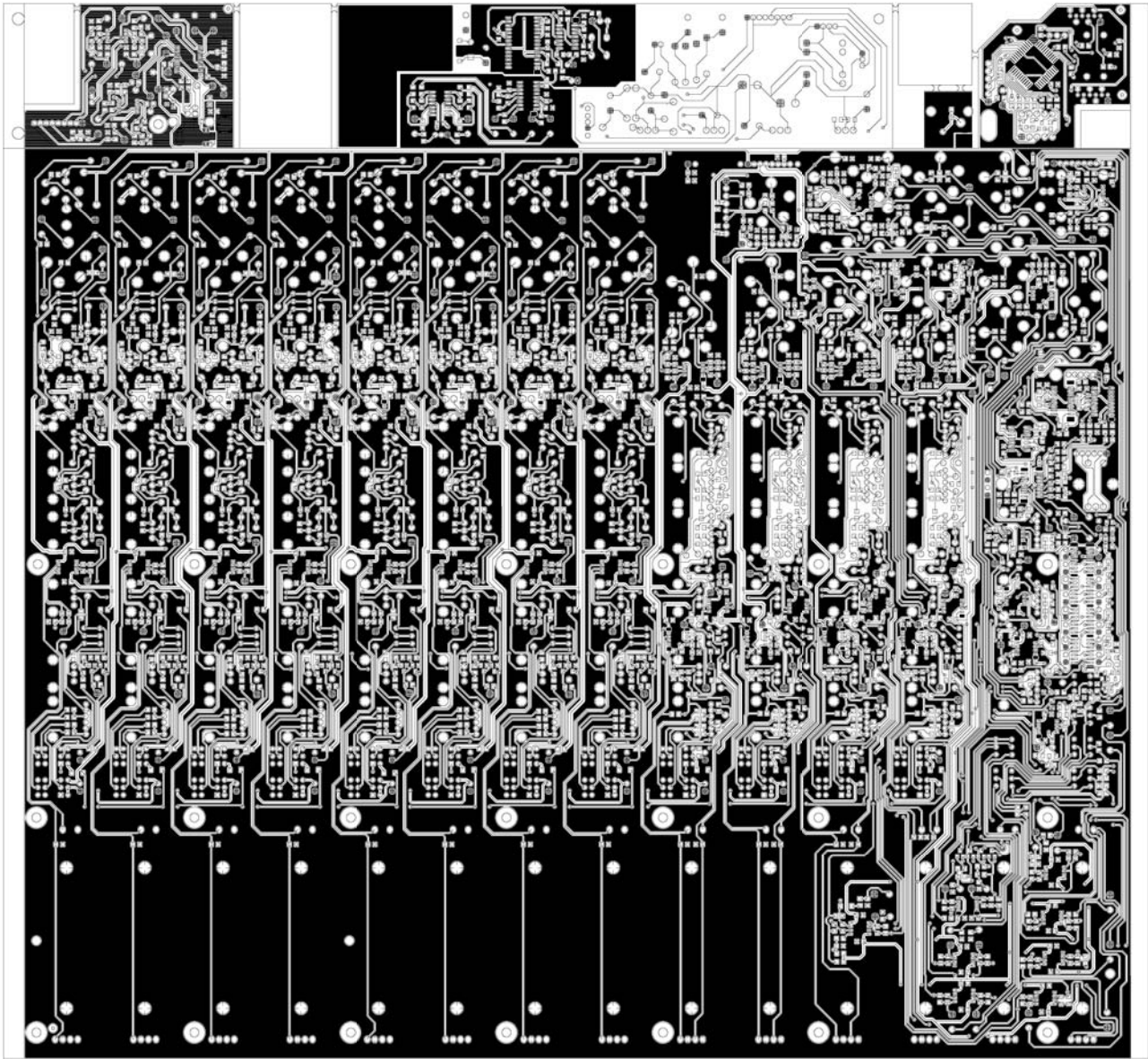

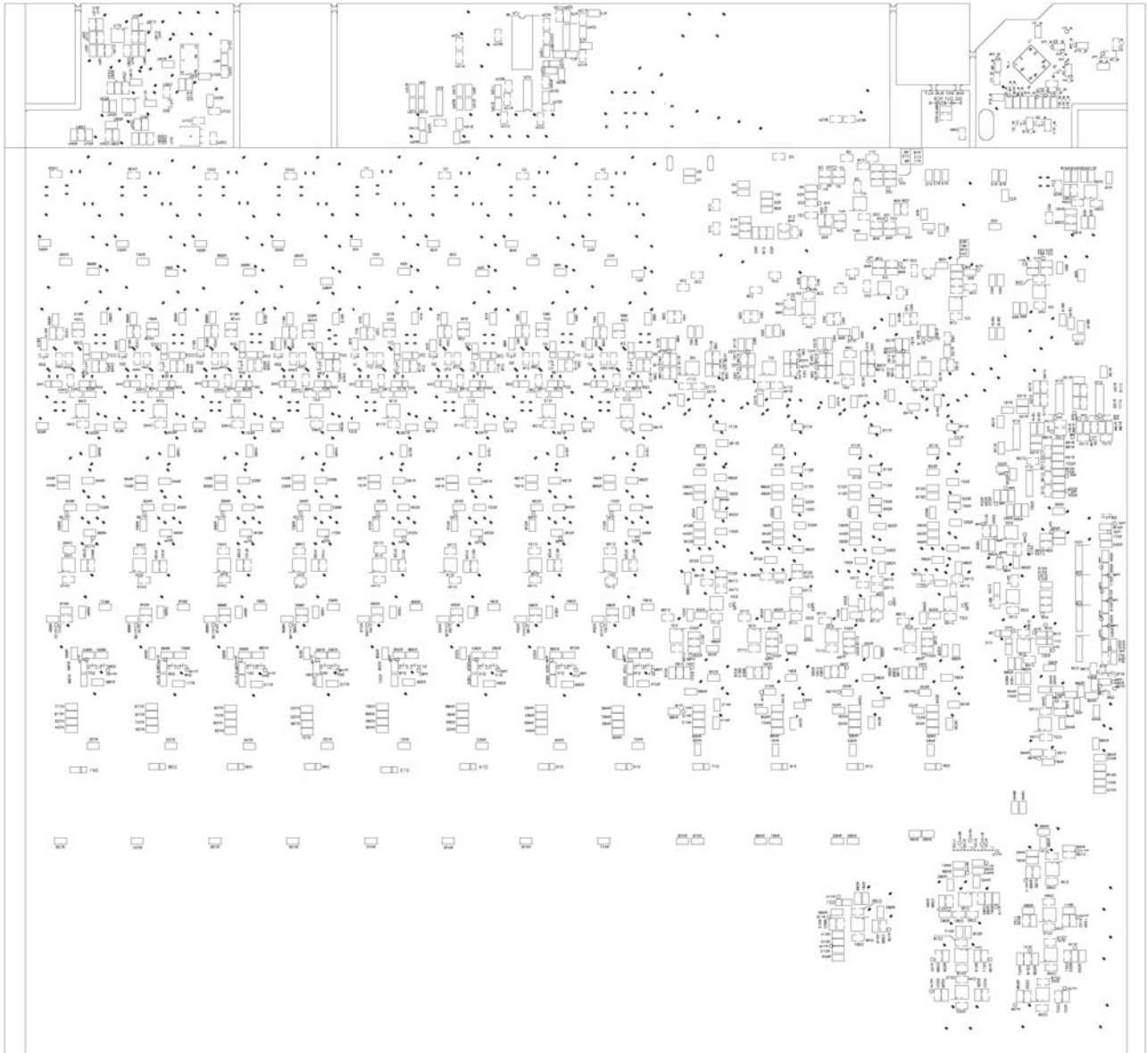

ALESIS

MultiMix 16 USB (XU7)

BOM

MULTIMIX 16USB BOM

LEVEL	P/N	DESCRIPTION	QTY	REF
1	PT1310617	KNOB CAP LARGE BLUE	1	33
1	PT1310618	KNOB LARGE	1	34
1	PT1310619	KNOB CAP SMALL BLUE	37	1
1	PT1310620	KNOB CAP SMALL GREEN	14	4
1	PT1310621	KNOB CAP SMALL RED	24	3
1	PT1310622	KNOB CAP SMALL BLACK	8	20
1	PT1310623	KNOB SMALL	74	2
1	PT1310624	SWITCH CAP	38	8
1	PT1310628	ENDCAP PLASTIC LEFT	1	7
1	PT1310627	ENDCAP PLASTIC RIGHT	1	23
1	MT1330019	FRONT PLATE	1	39
1	MT1330322	BOTTOM CHASSIS	1	31
1	SC0306RIBI	SCREW	39	5
1	MT130443701	ALUMINUM PAMEL	1	12
1	LAC22ALE26	STICKER BARCODE UPC	1	25
1	PXU7ALE02	PACK	1	
2	CGXU7310ALE01	INNER CARTON	1	
2	CTXU7513ALE01	OUTTER CARTON	0.5	
2	7-91-1002	GEL SILICA	1	
2	PLXA201	POLY FOAM	1	
2	7-51-1219	SHEET	1	
2	PE150350BO	POLYBAG	0.01	
2	PE5161304RHP	POLYBAG	0.01	
2	PUXA701	FOAM	1	
2	PLXA701	POLYFOAM	1	
2	7-51-0181	INSTRUCTION BOOK	1	
1	5-00-1308	SCREW	30	6
1	9-23-1024	FEET RUBBER	4	32
1	BATO-220	GASKET	1	18
1	NP613ALE27	NAME PLATE	1	36
1	PT1310626	SLIDER CAP	14	11
1	PT1310634	INDICATOR	14	10
1	PT1310625	SWITCH CAP	12	9
1	LAP67YAH255	LABEL	3	
1	RU1304406	RUBBER	1	41
1	RU1304407	GASKET	1	16
1	NUT0104IZI	NUT	4	45
1	CA040218001	6P CONNECTOR	1	
1	RU1304404	RUBBER	1	29
1	NP613ALE24	BEZEL LED DISPLAY XA SERIES MIXERS	1	35
1	PT1310633	KNOB	4	13
1	MT1304430	METEL PLATE	8	14
1	RU1304402	RUBBER	1	15
1	MT1303210	FIXED PLATE	1	19
1	PT1310635	KNOB	8	21
1	PT1310652	KNOB	1	22
1	LAC52ALE01	LABEL	1	30
1	WS114009605IN	WASHER	29	40
1	BAKCA-04	PCB HOLDER	2	43
1	CA040218001	6P CONNECTOR	1	44
1	TWJKMC010301	POWER ASS'Y	1	26
2	CN0320000802	3P CONNECTOR (80mm)	1	

MULTIMIX 16USB BOM

LEVEL	P/N	DESCRIPTION	QTY	REF
2	JKMC0103	MIC BASE	1	
1	TWSWRA19-20101	POWER SWITCH ASS'Y	1	28
2	CN0220000801	2P CONNECTOR (80mm)	1	
2	SWR19A-2	POWER SWITCH	1	
1	TWSWRS-001C-B	POWER SWITCH ASS'Y	1	27
2	CN0420000802	4P CONNECTOR (80mm)	1	
2	SWRS-001C-B	POWER SWITCH	1	
1	9-79-035801	MIXER PCB ASS'Y	1	24
2	9-79-0302-02	MICON PCB ASS'Y	1	17
3	EC22716TS	ELECT 220UF/16V (S)	1	M_C3
3	LDT2601G	LED	1	M_LED1
3	MT1303214	FIXED PLATE	1	(M_IC2)
3	RS10118J05	RESISTOR 100O (SMD)	3	M_R1,M_R16,M_R17
3	RS22118J05	RESISTOR 220O (SMD)	8	M_R6~M_R13
3	RS47018J05	RESISTOR 47O (SMD)	3	M_R4,M_R14,M_R15
3	RS47118J05	RESISTOR 470O (SMD)	2	M_R2,M_R3
3	TE162000601	TERMINAL	2	M_TE1,M_TE3
3	TRBC857B	TRANSISTOR BC857B	2	M_Q1,M_Q2
3	1-56-0104	CERAMIC 0.1UF (SMD)	4	M_C1,M_C2,M_C5,M_C15
3	2-27-0060	IC AL3201B	1	M_IC2
3	7-01-0033	CRYSTAL 12MHZ	1	M_M1
3	9-40-0302	MICON PCB	1	
3	9-61-0106	IC 87C518K	1	M_IC1
2	9-79-0320	DIGITAL OUT PCB ASS'Y	1	38
3	CS221J5005COG	CERAMIC 220P (SMD)	1	C561
3	MT1304439	FRAME PANEL	1	(J30)
3	RJ1081	RCA JACK	1	J30
3	RS10118J05	RESISTOR 100O (SMD)	1	R780
3	TE612000202	CONNECTOR 2P	1	PTE7
3	WR1317012B	CONNECTOR 2P (170mm)	1	(PTE7)
3	1-56-0104	CERAMIC 0.1UF (SMD)	1	C562
3	9-40-0320	DIGITAL OUT PCB	1	
2	9-79-035502	USB PCB ASS'Y	1	37
3	CS182K5005X7R	CERAMIC 1800P (SMD)	2	C15U,16U
3	CS220J5005COG	CERAMIC 22P (SMD)	2	C21U,22U
3	CS221J5005COG	CERAMIC 220P (SMD)	2	C17U,18U
3	CS331J5005COG	CERAMIC 330P (SMD)	2	C19U,20U
3	EC10550T	ELECT 1UF/50V	4	C3U,4U,5U,12U
3	EC10616T	ELECT 10UF/16V	6	C1U,2U,6U,7U,8U,9U
3	ICPCM2902E	IC PCM2902E	1	IC2U
3	RS10018J05	RESISTOR 100 (SMD)	1	R22U
3	RS10118J05	RESISTOR 100O (SMD)	2	R5U,8U
3	RS10518J05	RESISTOR 1M (SMD)	1	R9U
3	RS15218J05	RESISTOR 1K5 (SMD)	1	R19U
3	RS18318J05	RESISTOR 18K (SMD)	2	R1U,2U
3	RS22018J05	RESISTOR 22O (SMD)	2	R12U,13U
3	RS27318J05	RESISTOR 27K (SMD)	2	R3U,4U
2	RS39218J05	RESISTOR 3K9 (SMD)	2	R6U,7U

MULTIMIX 16USB BOM

LEVEL	P/N	DESCRIPTION	QTY	REF
3	TE612000202	CONNECTOR 2P	1	(TE3U)
3	TE612000301	CONNECTOR 3P	1	(TE2U)
3	TE612000901	CONNECTOR 9P	1	(TE1U)
3	XTM12000X3	CRYSTAL 12MHz	1	X1U
3	1-56-0104	CERAMIC 0.1UF (SMD)	1	C27U
3	2-71-0082	IC TL082	1	IC1U
3	4-08-0402	USB PLUG	1	USB1
3	9-40-0355	USB PCB	1	
2	9-79-0357-01	POWER PCB ASS'Y	1	42
3	CN0320002201	3P CONNECTOR (220mm)	1	PTE12
3	CS103Z5005Y5V	CERAMIC 0.01UF (SMD)	4	PC16,20,22,32
3	CS330J5005COG	CERAMIC 33P (SMD)	2	PC13,19
3	CS332K5005X7R	CERAMIC 3300P (SMD)	2	PC15,31
3	DIENLL4148SM	DIODE	1	PD12
3	DIN4002	DIODE	8	PD10,11,13,14,16,17,18,19
3	DIZBZX79C47V	DIODE	1	PD15
3	EC107100	ELECT 100UF/100V	1	PC35
3	EC10735T	ELECT 100UF/35V	1	PC40
3	EC10835	ELECT 1000UF/35V	2	PC42,47
3	EC476100	ELECT 47UF/100V	2	PC36,46
3	EC47625T	ELECT 47UF/25V	10	PC18,24,25,26,27,29,33,37,44,45
3	EC47650T	ELECT 47UF/50V	2	PC30,41
3	ICCS8405A	IC CS8405A	1	PU1
3	IC7805	IC 7805	2	PIC7,9
3	IC7815	IC 7815	1	PIC8
3	IC7915	IC 7915	1	PIC6
3	NUT0130IID	NUT	1	(PIC9)
3	RS00018J05	RESISTOR 00 (SMD)	1	PL12
3	RS10118J05	RESISTOR 1000 (SMD)	2	PR22,24
3	RS10318F05	RESISTOR 10K (SMD)1%	7	PR13,14,15,20,21,25,26
3	RS10518J05	RESISTOR 1M (SMD)	1	PR23
3	RS27218J05	RESISTOR 2K7 (SMD)	2	PR17,18
3	RS33118J05	RESISTOR 3300 (SMD)	4	PR7,9,10,12
3	RS39118J05	RESISTOR 3900 (SMD)	2	PR8,30
3	RS47118J05	RESISTOR 4700 (SMD)	3	PR11,16,28
3	R10018	RESISTOR 100 1/4W	1	PR31
3	R10318	RESISTOR 10K 1/4W	1	PR27
3	R20318	RESISTOR 20K 1/4W	1	PR19
3	R39418	RESISTOR 390K 1/4W	1	PR29
3	SC0308RIZI	SCREW	1	(PIC9)
3	TE512540301	TERMINAL 3P 2.54mm	1	PJ1
3	TE612000202	CONNECTOR 2P	2	(PTE5,6)
3	TE612000301	CONNECTOR 3P	2	(PTE9,10)
3	TE612000402	CONNECTOR 4P	1	(PTE11)
3	TE612000801	CONNECTOR 8P	1	(PTE8)
3	TE812000311	CONNECTOR 3P	1	(PTE12)
3	TE8731002	MINI JUMP	1	(PJ1)
3	TRBD239C	TRANSISTOR BD239C	1	PIC5
3	UH11-2012-102T	BEAD (SMD)	2	PL1,3
3	WR1325012W1	WIRE (250mm)	1	PTE13
3	1-56-0104	CERAMIC 0.1UF (SMD)	9	PC14,17,21,23,28,34,38,39,43
3	2-62-1004	IC 74AHCU04	1	PU2

MULTIMIX 16USB BOM

LEVEL	P/N	DESCRIPTION	QTY	REF
3	2-71-0084	IC TL084	1	PU3
3	2-75-1101	IC AL1101	1	PU4
3	7-01-0023	CRYSTAL 11.2896MHz	1	PM1
3	7-01-0024	CRYSTAL 12.288MHz	1	PM2
3	9-40-0357	POWER PCB	1	
2	9-79-0358	MIXER PCB ASS'Y	1	
3	CN0820001101	8P CONNECTOR (110mm)	1	TE1
3	CN0920003601	9P CONNECTOR (360mm)	1	ET5
3	CS100J5005COG	CERAMIC 10P (SMD)	2	C38,40
3	CS101J5005COG	CERAMIC 100P (SMD)	28	C6,8,10,11,14,21,24,26,28,29,32,34,35,36,37,41,42,45,60,61,62,63,65,66,67,68,160,163
3	CS102K5005X7R	CERAMIC 1000P (SMD)	2	C125,127
3	CS103K5005X7R	CERAMIC 0.01UF (SMD)	1	C5
3	CS200J5005COG	CERAMIC 20P (SMD)	78	51,69,87~96,99~102,105,132,134,136,138,140,143,148,150,151,153,154,156,157,159,164~167,170,174,178,182,185~188,193,195,196,198,200,203,209,211,214,217,218,221,469,470,471,474,477~480,563,566
3	CS331J5005COG	CERAMIC 330P (SMD)	30	4,129~131,429~432,441~445,447,449,451
3	CS470J5005COG	CERAMIC 47P (SMD)	5	C208,222,224,225,227
3	CS681J5005COG	CERAMIC 680P (SMD)	16	C52~59,433~440
3	DIENLL4148SM	DIODE	49	D1~49
3	EC10625T	ELECT 10UF/25V	17	C233,235,237,239,251,254,257,260,277,485,487,489,491,497,500,503,506
3	EC10635TS	ELECT 10UF/35V (S)	1	C306
3	EC10710TS	ELECT 100UF/10V (S)	16	C376~379,384~387,549~556
3	EC10806T	ELECT 1000UF/6.3V	8	C253,256,259,262,499,502,505,507
3	EC22450T	ELECT 0.22UF/50V	16	C241~244,252,255,258,261,493~496,498,501,504,508
3	EC22450TS	ELECT 0.22UF/50V (S)	8	C279,282,286,288,510,514,516,520
3	EC22550TS	ELECT 2.2UF/50V (S)	9	C395~398,417,557~560
3	EC22616TS	ELECT 22UF/16V (S)	5	C265,275,276,348,350
3	EC22710TS	ELECT 220UF/10V (S)	16	C388,389,390,391,399,400,401,402,403,404,405,406,408,409,410,411
3	EC47625TS	ELECT 47UF/25V (S)	73	C232,245~250,263,264,266~274,278,280,281,283,284,285,287,289,349,351~354,358,359,367,372,374,375,380~383,392~394,407,412~416,418~428,509,511~513,515,517~519,545~548
3	EC47650T	ELECT 47UF/50V	16	C228~231,234,236,238,240,481~484,486,488,490,492
3	IC4580L	IC NJM4580L	1	IC47
3	JK5031	XLR BASE	8	MIC1~8
3	JK6353-02-250	6.3F BASE	29	J1~29
3	LD-LG2040	GREEN LED	12	LED3,4,11,12,13,14,16,17,18,19,20,21
3	LDLT0311-41	RED LED	15	LED2,7,9,22~29,38,39,40,41
3	LDLY2040A	YELLOW LED	17	LED5,6,8,10,15,30~37,42~45
3	LDU326V4M	GREEN LED	1	LED1
3	MC12350TTF	MALYER CAP 0.012UF/50VJ	32	326,328,330~334,336,338,340,342,355,360,364,369,530,532,534,536,538,540,542,544
3	MC18350TTF	MALYER CAP 0.018UF/50VJ	32	C290~292,294~296,298~300,302~304,307~315,317,319,321,521~528

MULTIMIX 16USB BOM

LEVEL	P/N	DESCRIPTION	QTY	REF
3	MC33350TTF	MALYER CAP 0.033UF/50VJ	32	C323,325,327,329,335,337,339,341,343~347,356,357,361~363,365,366,368,370,371,373,529,531,533,535,537,539,541,543
3	MR249116	RESISTOR 2.49K 1/16W	16	R550~557,756~763
3	MR392116	RESISTOR 3.92K 1/16W	16	R566~573,772~779
3	MR680116	RESISTOR 6.8K 1/16W	16	R532~535,540,543,546,549,740~743,746,749,752,755
3	MR825016	RESISTOR 825O 1/16W	16	R558~565,764~771
3	MT1305501	COLLAR SHAFT	21	
3	PT111040105	FIXED BASE LED	44	(LED2~45)
3	PT1310658	LED HOLDER	1	(LED1)
3	RJGJ107NI	RCA JACK	1	RCA1
3	RS04718J05	RESISTOR 4.7O (SMD)	8	R74,79,84,89,605,608,610,612
3	RS10018J05	RESISTOR 10O (SMD)	1	R136
3	RS10118J05	RESISTOR 100O (SMD)	3	R270,394,395
3	RS10218F05	RESISTOR 1K (SMD)1%	8	R184,186,224,228,231,264,590,591
3	RS10318F05	RESISTOR 10K (SMD)1%	112	R5~11,23~26,28,36~43,45,47~49,59,60,90~95,97~99,101~103,114,119,124,129,150,151,234,237,240,243,248,253,258,262,263,268,276,278,281,284,296,299,302,305,312,314,333,338,343,349,357,361,366,372,377,380,383,386,432,440~443,470,471,503,504,506,507,509,511,512,514,592~599,657,659,661,663,676,678,680,682,708,710,712,714,782
3	RS10418J05	RESISTOR 100K (SMD)	5	R388,392,488,495,524
3	RS10518J05	RESISTOR 1M (SMD)	16	R272~275,277,279,282,286,672~675,308,309,311,314
3	RS12118J05	RESISTOR 120O (SMD)	22	R4,12,13,15,16,21,27,29,30,31,32,33,63,64,68,69,104,105,106,108,223,267
3	RS12318J05	RESISTOR 12K (SMD)	4	R472,473,491,493
3	RS13218F05	RESISTOR 1K3 (SMD)1%	25	R71,73,76,78,81,83,86,88,159,162,165,168,317,607,614,615,616,618,619,621,622,633,635,637,639
3	RS15218J05	RESISTOR 1K5 (SMD)	26	R1,2,298,301,304,307,310,334,335,339,340,345,348,350,414,415,422,423,430,431,438,439,677,679,681,683
3	RS15318J05	RESISTOR 15K (SMD)	6	R61,67,468,486,499,515
3	RS18218J05	RESISTOR 1K8 (SMD)	2	R418,426
3	RS20318J05	RESISTOR 20K (SMD)	32	R14,51,72,77,82,87,141~146,148,149,157,160,163,166,492,501,502,505,517,518,604,606,609,611,632,634,636,638
3	RS22118F05	RESISTOR 220O (SMD)1%	1	R355
3	RS22218J05	RESISTOR 2K2 (SMD)	18	R17,34,158,161,164,167,169,171~176,178,640~643
3	RS22318J05	RESISTOR 22K (SMD)	14	R408,409,416,417,424,425,433,434,444,447,448,449,496,498
3	RS22418J05	RESISTOR 220K (SMD)	1	R513
3	RS27218J05	RESISTOR 2K7 (SMD)	6	R179,182,459,461,463,465
3	RS27318J05	RESISTOR 27K (SMD)	28	R396,398,399,401,402,404,405,407,412,413,420,421,428,429,436,437,446,466,522,528,716,718,721,722,725,727,728,730
2	RS27418F05	RESISTOR 270K (SMD)1%	16	R574~585,664~667
3	RS30218J05	RESISTOR 3K (SMD)	2	R410,781
3	RS30318F05	RESISTOR 30K (SMD)1%	18	R50,65,115,116,117,118,120,121,122,123,125,126,127,128,130,131,132,133
3	RS33218J05	RESISTOR 3K3 (SMD)	2	R508,510
3	RS33318J05	RESISTOR 33K (SMD)	4	R58,96,519,526

MULTIMIX 16USB BOM

LEVEL	P/N	DESCRIPTION	QTY	REF
3	RS33418J05	RESISTOR 330K (SMD)	1	R393
3	RS36218J05	RESISTOR 3K6 (SMD)	2	R351,390
3	RS39218J05	RESISTOR 3K9 (SMD)	10	R226,266,319,322,325,328,684,686,688,690
3	RS43118F05	RESISTOR 430 O (SMD)1%	1	R353
3	RS47118F05	RESISTOR 470O (SMD)1%	7	R134,135,154,155,156,352,354
3	RS47218J05	RESISTOR 4K7 (SMD)	56	R297,300,303,306,320,323,326,329,331,332,336,337,341,342,346,347,358,363,368,373,376,378,379,381,382,384,385,387,474~485,685,687,689,691~693,695,696,698,699,701,702,736~739
3	RS47318J05	RESISTOR 47K (SMD)	26	R356,359,362,364,367,369,371,374,451,453,455,457,489,497,704,705,706,707,709,711,713,715,732~735
3	RS51118F05	RESISTOR 510O (SMD)	16	R70,75,80,85,110,111,112,113,613,617,620,623~627
3	RS51218J05	RESISTOR 5K1 (SMD)	43	R19,20,44,46,52,66,287~292,313,315,397,400,403,406,411,419,427,435,445,450,452,454,456,458,460,462,464,467,500,523,527,717,719,720,723,724,726,729,731
3	RS51318J05	RESISTOR 51K (SMD)	2	R490,494
3	RS56018J05	RESISTOR 56O (SMD)	1	R181
3	RS56118J05	RESISTOR 560O (SMD)	16	R193,196,199,202,204,206,209,212,214,217,219,221,646,649,652,655
3	RS56218J05	RESISTOR 5K6 (SMD)	2	R520,521
3	RS56318J05	RESISTOR 56K (SMD)	4	R100,107,109,147
3	RS62118F05	RESISTOR 620O (SMD)1%	1	R316
3	RS62218J05	RESISTOR 6K2 (SMD)	2	R18,35
3	RS62318J05	RESISTOR 62K (SMD)	10	R137~140,389,391,628~631
3	RS68118J05	RESISTOR 680O (SMD)	1	R183
3	RS68218F05	RESISTOR 6K8 (SMD)1%	53	R54~57,180,232,233,235,236,238,239,241,242,244~247,249~251,254,255,256,259~261,280,283,285,360,365,370,375,586~589,600~603,656,658,660,662,668~671,694,697,700,703
3	RS75218F05	RESISTOR 7K5 (SMD)1%	5	R295,525,529,530,531
3	RS82118J05	RESISTOR 820O (SMD)	2	R271,293
3	RS82218F05	RESISTOR 8K2 (SMD)1%	8	R53,62,225,265,294,469,487,516
3	RS91118F05	RESISTOR 910O (SMD)1%	33	R170,177,191,192,194,195,197,198,200,201,203,205,207,208,210,211,213,215,216,218,220,222,252,257,318,644,645,647,648,650,651,653,654
3	R04716	RESISTOR 4.7O 1/16W	16	R538,539,541,542,544,545,547,548,744,745,747,748,750,751,753,754
3	R18316T	RESISTOR 18K (SMD)	2	R536,537
3	SC0306RIBI	SCREW	21	
3	SWSFPC12MC02	PUSH SWITCH	26	SW1~14,23,24,33~42
3	SWSFPC14MA01	PUSH SWITCH	24	SW15~22,25~32,43~50
3	TE162000602	TERMINAL	2	TE3,4
3	TE812000811	8P CONNECTOR	1	(TE1)
3	TE812000911	9P CONNECTOR	1	(TE5)
3	TRA1316GR	TRANSISTOR SA1316GR	16	Q21~28,45~52
3	TRBC847B	TRANSISTOR BC847B	32	Q1~8,10~17,29~44
3	TRBC857B	TRANSISTOR BC857B	4	Q9,18,19,20
3	TRBF513	TRANSISTOR BF513	4	FET1,2,3,4
3	VRK10301202	VR 103AC	12	VR49~56,91~94
3	VRK1030904	VR 103W	24	VR31~38,40~47,83~90

MULTIMIX 16USB BOM

LEVEL	P/N	DESCRIPTION	QTY	REF
3	VRK5020902	VR 502R	8	VR1~4,67~70
3	VRK50301203	VR 503B	12	VR9~12,17~20,26~29
3	VRK50301204	VR 503W	3	VR30,39,48
3	VRK5030903	VR 503B	24	VR5~8,13~16,22~25,71~82
3	VRS10306007	VR 10KD	8	VR57~60,95~98
3	VRS10306008	VR 10KDX2	6	VR61~66
3	WR1030052W1	CONNECTOR 3P	1	TE2
3	0-16-1472	RESISTOR 14.7K (SMD)1%	4	R182,227,229,230
3	0-16-6041	RESISTOR 6.04K (SMD)1%	2	R152,153
3	0-16-7321	RESISTOR 7.32K (SMD)1%	4	R187~190
3	1-56-0104	CERAMIC 0.1UF (SMD)	120	C9,18,20,25,39,43,44,47,49,50,64,70,73,74,77,78,81,82,85,86,97,98,103,104,106,107~121,126,128,133,135,137,139,14,1142,144~147,149,152,155,158,161,162,68,169,171,172,173,175~177,179~181,183,184,189,190~192,194,197,199,201,202,204,205~207,210,212,213,215,216,219,220,223,226,269,446,448,450,452~468,472,473,475,476,564,565
3	2-71-0084	IC TL084	1	IC17
3	2-71-4580	IC NJM4580E	46	IC1~13,18~22,24~28,31~35,37~45,48~56
3	2-72-0339	IC LM339	5	IC16,23,29,30,36
3	2-75-1101	IC AL1101	1	IC14
3	2-75-1201	IC AL1201	1	IC15
3	6-00-0008	ENCODER	1	VR21
3	9-40-0358	MIXER PCB	1	