

AG6991_1 Page 1
AG6991_1 Page 1.Sch

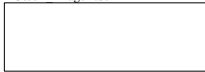

AG6991_1 page 2
AG6991_1 page 2.Sch

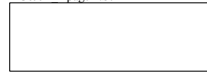

ALLEN&HEATH

Kernick Industrial Estate,
Penryn, Cornwall,
England. TR10 9LU
Tel: +44 (0)1326 372070
Fax: +44 (0)1326 370153

ISSUE	BY	DATE	CHK BY
1	ARJ	21/06/07	

FILE: Sheet1.Sch

* All parts to be RoHS Compliant *

PRINTED: 12:19:36 12-Nov-2007

TITLE: XONE 42 INPUT
PAGE:

DRG No: C6991 ISSUE: 1 SHEET: 0 OF 2

A

I

B

C

D

E

F

G

H



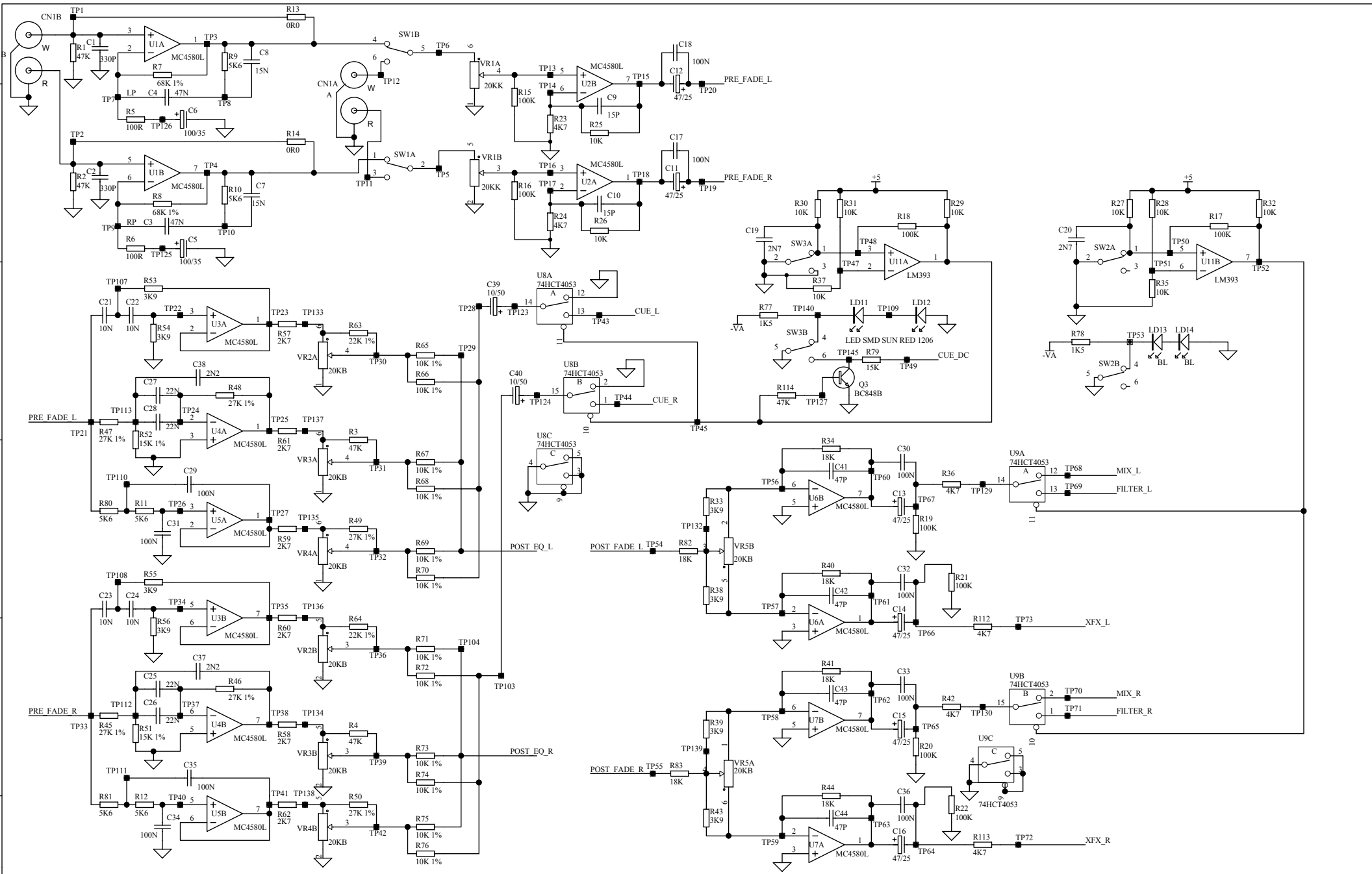

ALLEN&HEATH
 Kernick Industrial Estate,
 Penryn, Cornwall,
 England. TR10 9LU
 Tel: +44 (0)1326 372070
 Fax: +44 (0)1326 370153

ISSUE	BY	DATE	CHK BY
1	ARJ	21-06-07	

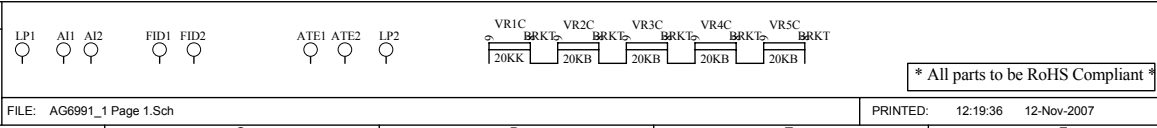

TITLE: **XONE 42 INPUT**
 PAGE:
 DRG No: **C6991** ISSUE: 1 SHEET: 1 OF 2

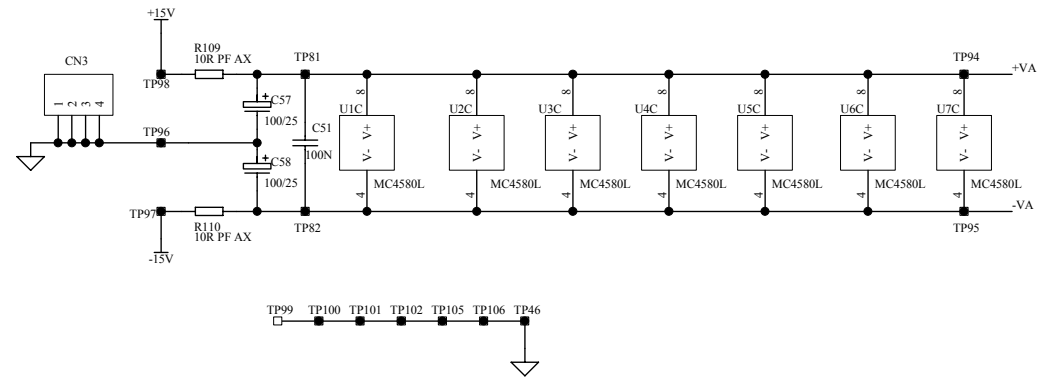
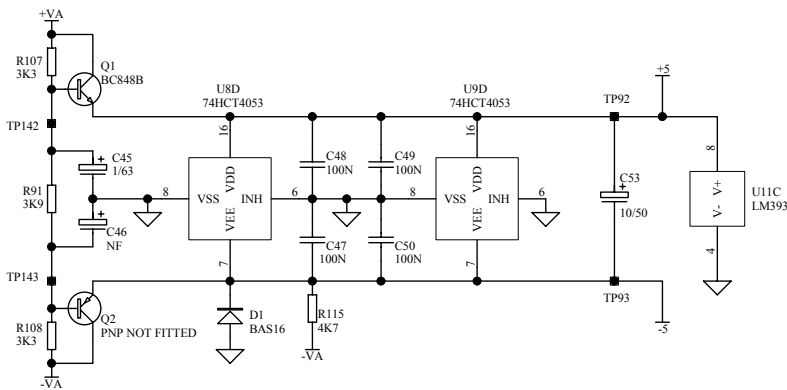
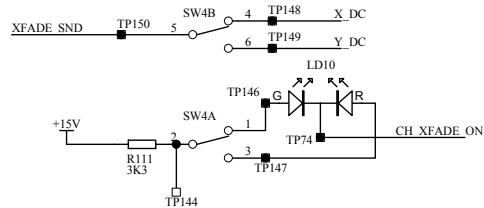
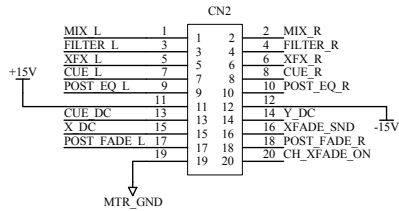
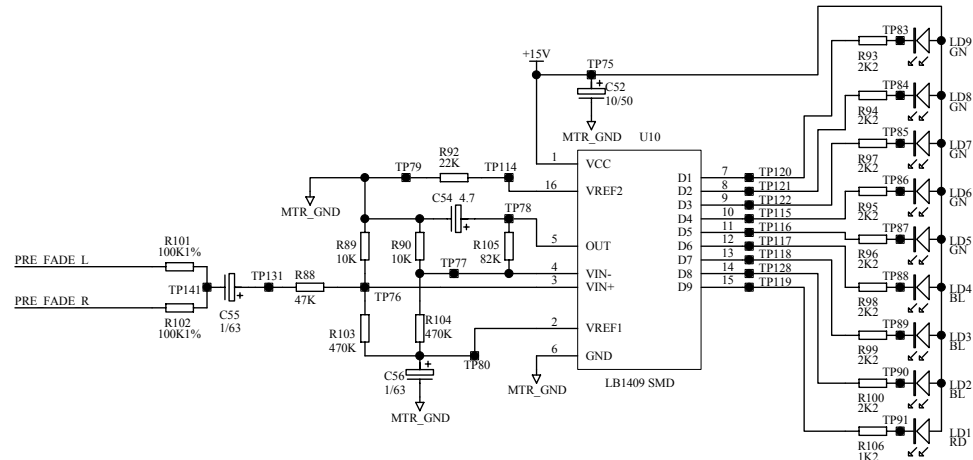

ALLEN&HEATH

Kernick Industrial Estate,
Penryn, Cornwall,
England. TR10 9LU
Tel: +44 (0)1326 372070
Fax: +44 (0)1326 370153

ISSUE	BY	DATE	CHK BY
1	ARJ	21-06-07	

FILE: AG6991_1 page 2.Sch

TITLE: XONE 42 INPUT

PAGE:

* All parts to be RoHS Compliant *

DRG No: C6991

ISSUE: 1

SHEET: 2 OF 2

PRINTED: 12:19:37 12-Nov-2007

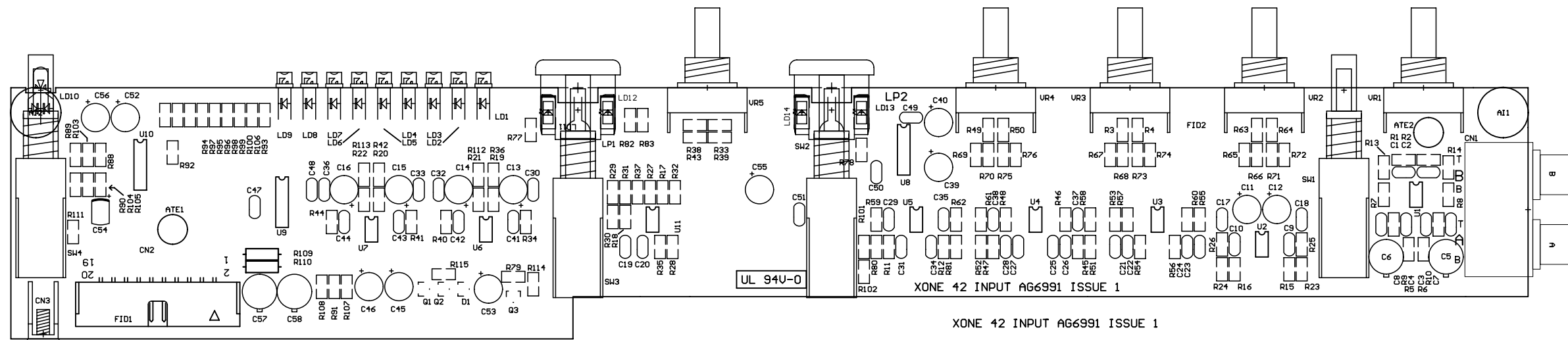

XONE 42 INPUT A66991 ISSUE 1

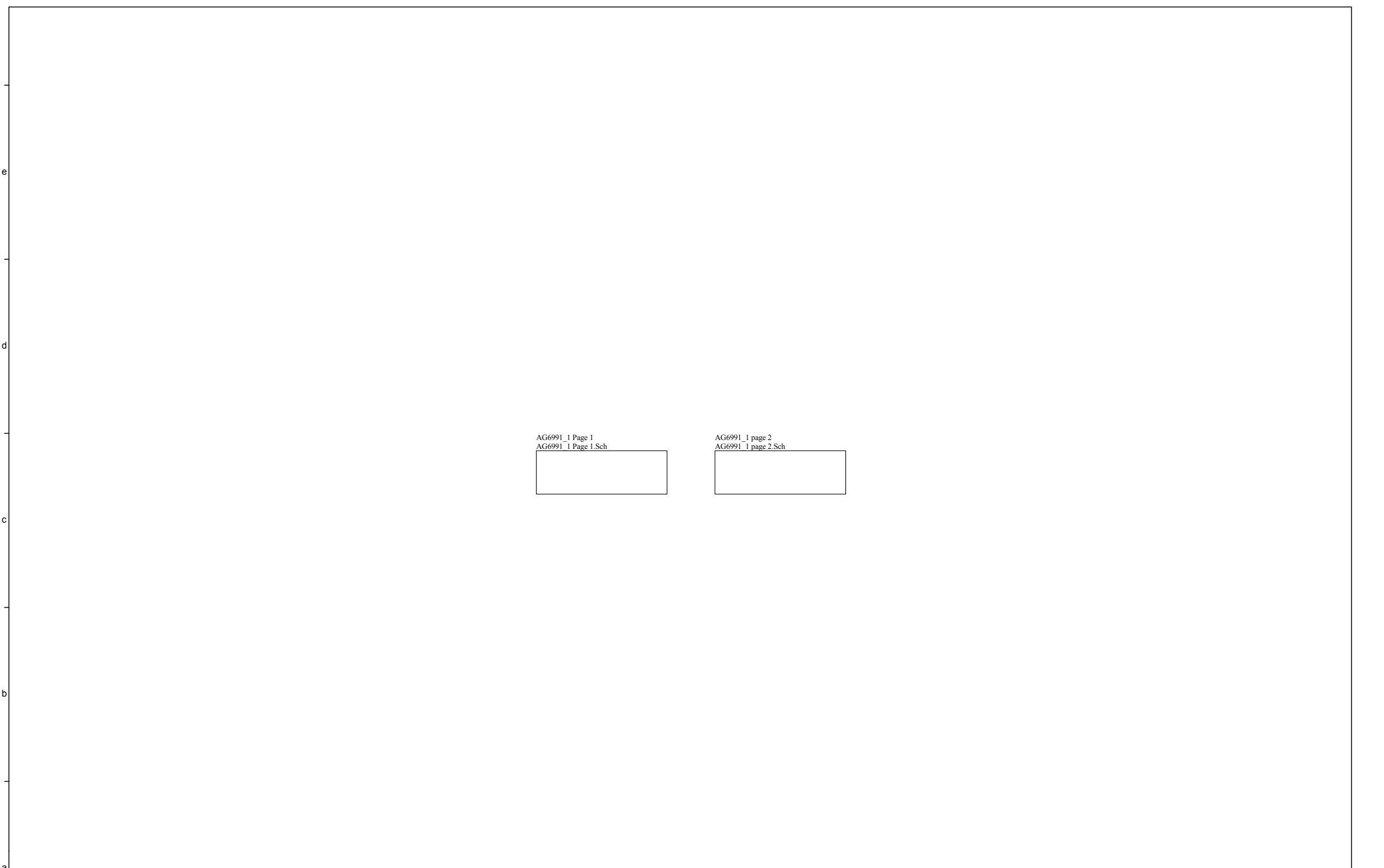

AG6991_1 Page 1
AG6991_1 Page 1.Sch



AG6991_1 page 2
AG6991_1 page 2.Sch

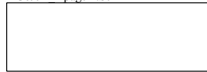

ALLEN&HEATH

Kernick Industrial Estate,
Penryn, Cornwall,
England. TR10 9LU
Tel: +44 (0)1326 372070
Fax: +44 (0)1326 370153

ISSUE	BY	DATE	CHK BY
1	ARJ	21/06/07	

FILE: Sheet1.Sch

* All parts to be RoHS Compliant *

PRINTED: 12:19:36 12-Nov-2007

TITLE: XONE 42 INPUT

PAGE:

DRG No: C6991 ISSUE: 1 SHEET: 0 OF 2

A

I

B

C

D

E

F

G

H



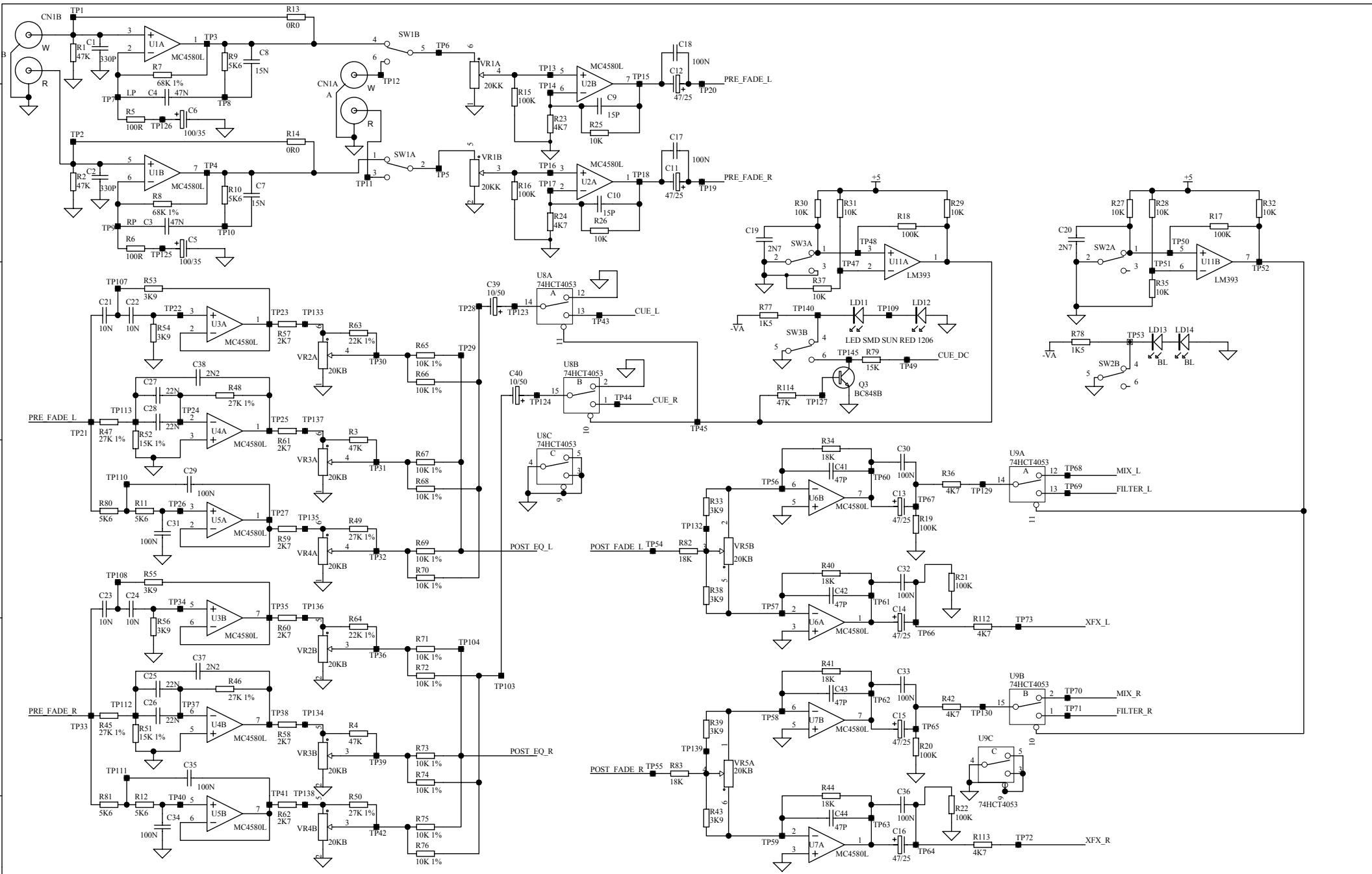

ALLEN&HEATH
 Kernick Industrial Estate,
 Penryn, Cornwall,
 England. TR10 9LU
 Tel: +44 (0)1326 372070
 Fax: +44 (0)1326 370153

ISSUE	BY	DATE	CHK BY
1	ARJ	21-06-07	

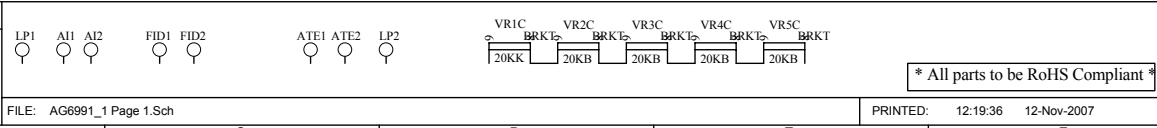

TITLE: **XONE 42 INPUT**
 PAGE:
 DRG No: **C6991** ISSUE: 1 SHEET: 1 OF 2

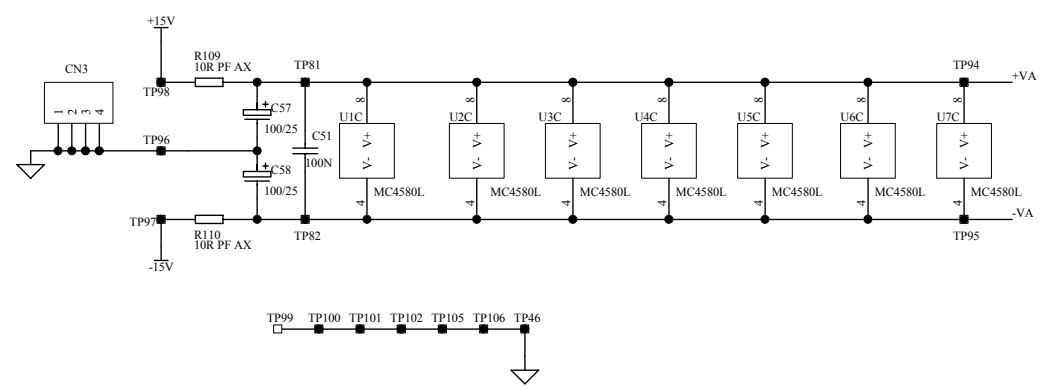
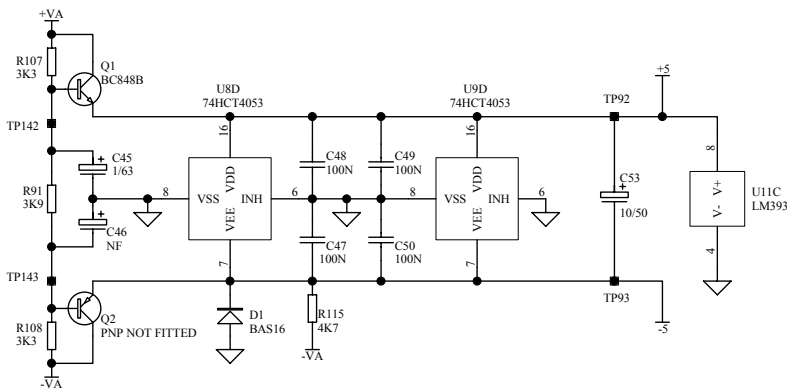
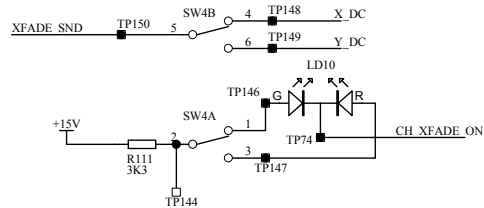
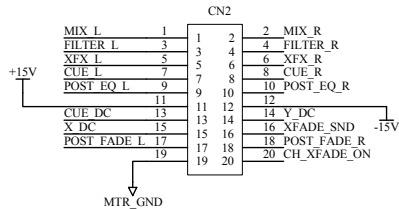
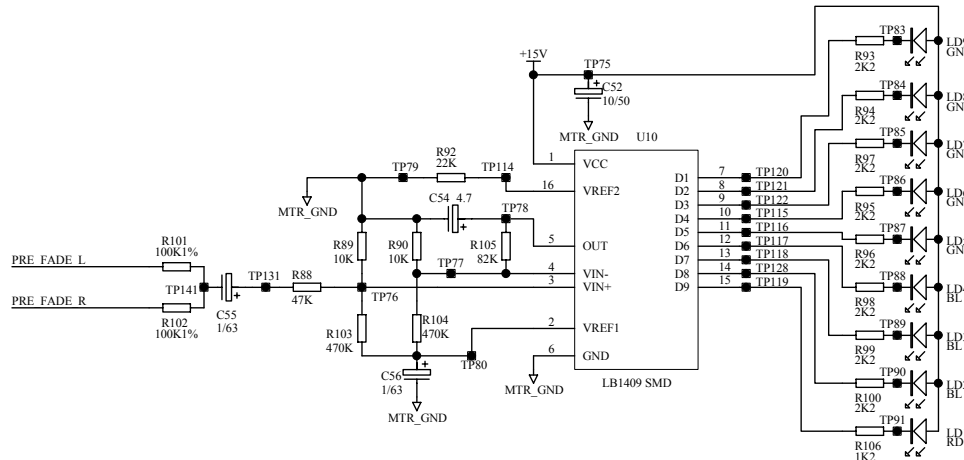

ALLEN&HEATH

Kernick Industrial Estate,
Penryn, Cornwall,
England. TR10 9LU

Tel: +44 (0)1326 372070
Fax: +44 (0)1326 370153

ISSUE	BY	DATE	CHK BY
1	ARJ	21-06-07	

FILE: AG6991_1 page 2.Sch

TITLE: XONE 42 INPUT

PAGE:

* All parts to be RoHS Compliant *

DRG No: C6991

ISSUE: 1

SHEET: 2 OF 2

PRINTED: 12:19:37 12-Nov-2007

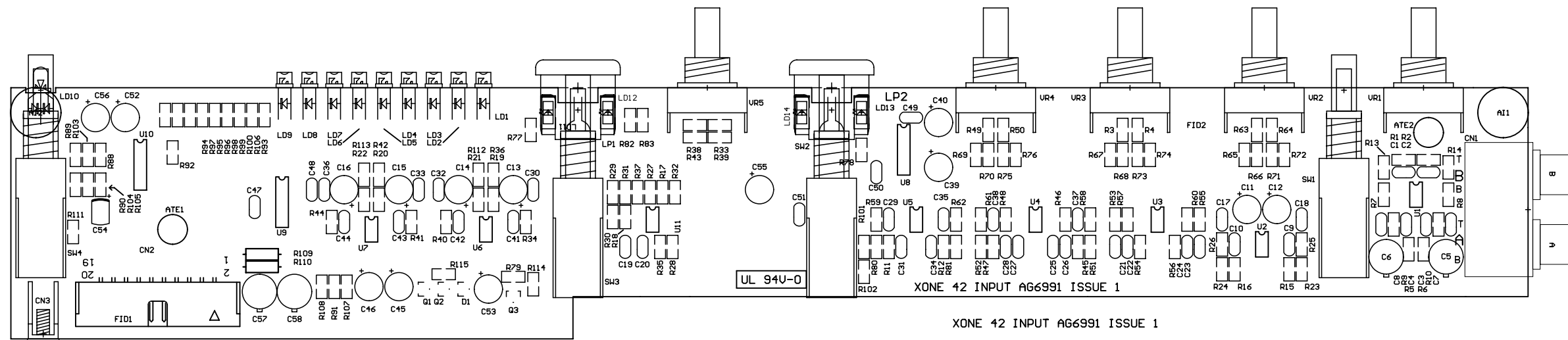

XONE 42 INPUT A66991 ISSUE 1

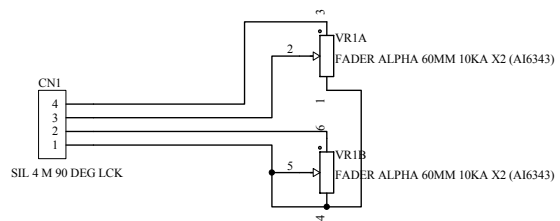

ALLEN&HEATH

Kernick Industrial Estate,
Penryn, Cornwall,
England. TR10 9LU

Tel: +44 (0)1326 372070
Fax: +44 (0)1326 370153

ISSUE	BY	DATE	CHK BY
1	ARJ	27-06-07	

FILE: C7077_1 INPUT FADER.Sch

PRINTED: 12:11:36 12-Nov-2007

TITLE: XONE 42 INPUT FADER

PAGE:

DRG No: C7077 ISSUE: I SHEET: 1 OF 1

A

I

B

I

C

I

D

I

E

I

F

I

G

I

H



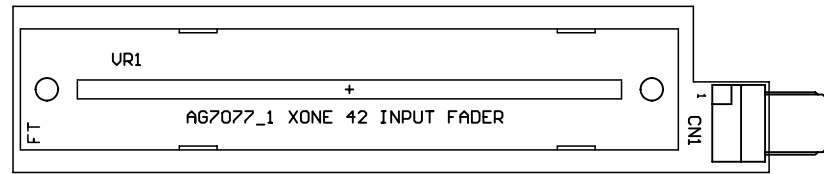

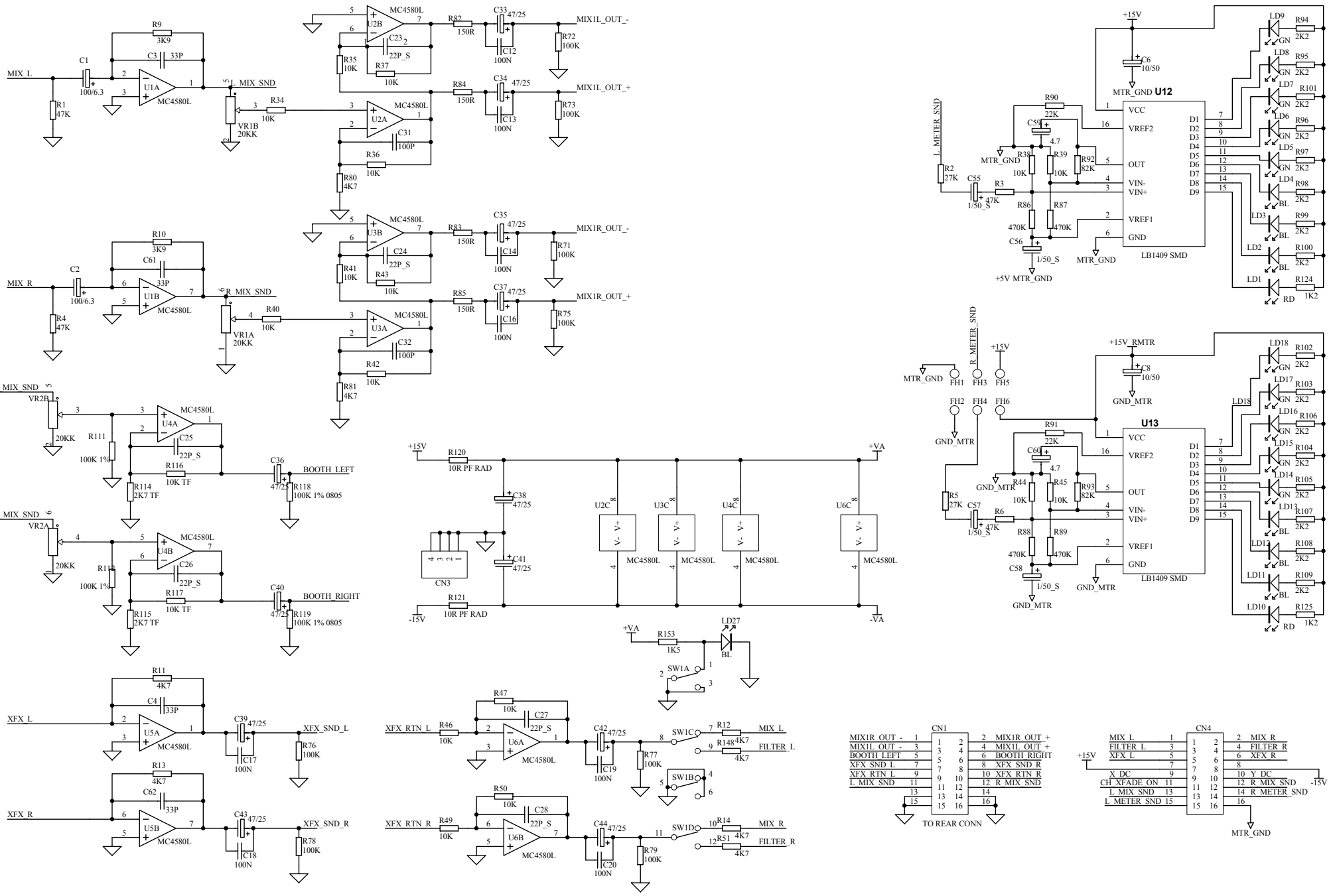

ALLEN&HEATH

Kernick Industrial Estate,
Penryn, Cornwall,
England. TR10 9LU
Tel: +44 (0)1326 372070
Fax: +44 (0)1326 370153

ISSUE	BY	DATE	CHK BY
1	ARJ	21-06-07	

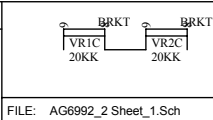

FILE: AG6992_2 Sheet_1.Sch

TITLE: **XONE 42 MASTER**

PAGE:
DRG No: C6992 ISSUE: 2 SHEET: 1 OF 3

* All parts to be RoHS Compliant *

PRINTED: 13:49:03 12-Nov-2007

CN1		CN4	
1	MIX1R OUT -	1	MIX R
2	MIX1R OUT +	2	MIX L
3	MIX1L OUT -	3	FILTER L
4	MIX1L OUT +	4	FILTER R
5	BOOTH LEFT	5	XFX L
6	BOOTH RIGHT	6	XFX R
7	XFX SND L	7	X DC
8	XFX SND R	8	10 Y DC
9	XFX RTN L	9	10 Y DC
10	XFX RTN R	10	12 R MIX SND
11	L MIX SND	11	12 R MIX SND
12	R MIX SND	12	14 R METER SND
13	L MIX SND	13	14 R METER SND
14	L METER SND	14	16
15	L METER SND	15	16
16	L METER SND	16	16

CN4		CN4	
1	MIX R	1	MIX R
2	MIX L	2	MIX L
3	FILTER L	3	FILTER R
4	FILTER R	4	FILTER R
5	XFX L	5	XFX R
6	XFX R	6	XFX R
7	X DC	7	X DC
8	10 Y DC	8	10 Y DC
9	10 Y DC	9	10 Y DC
10	12 R MIX SND	10	12 R MIX SND
11	12 R MIX SND	11	12 R MIX SND
12	14 R METER SND	12	14 R METER SND
13	14 R METER SND	13	14 R METER SND
14	14 R METER SND	14	14 R METER SND
15	16	15	16
16	16	16	16

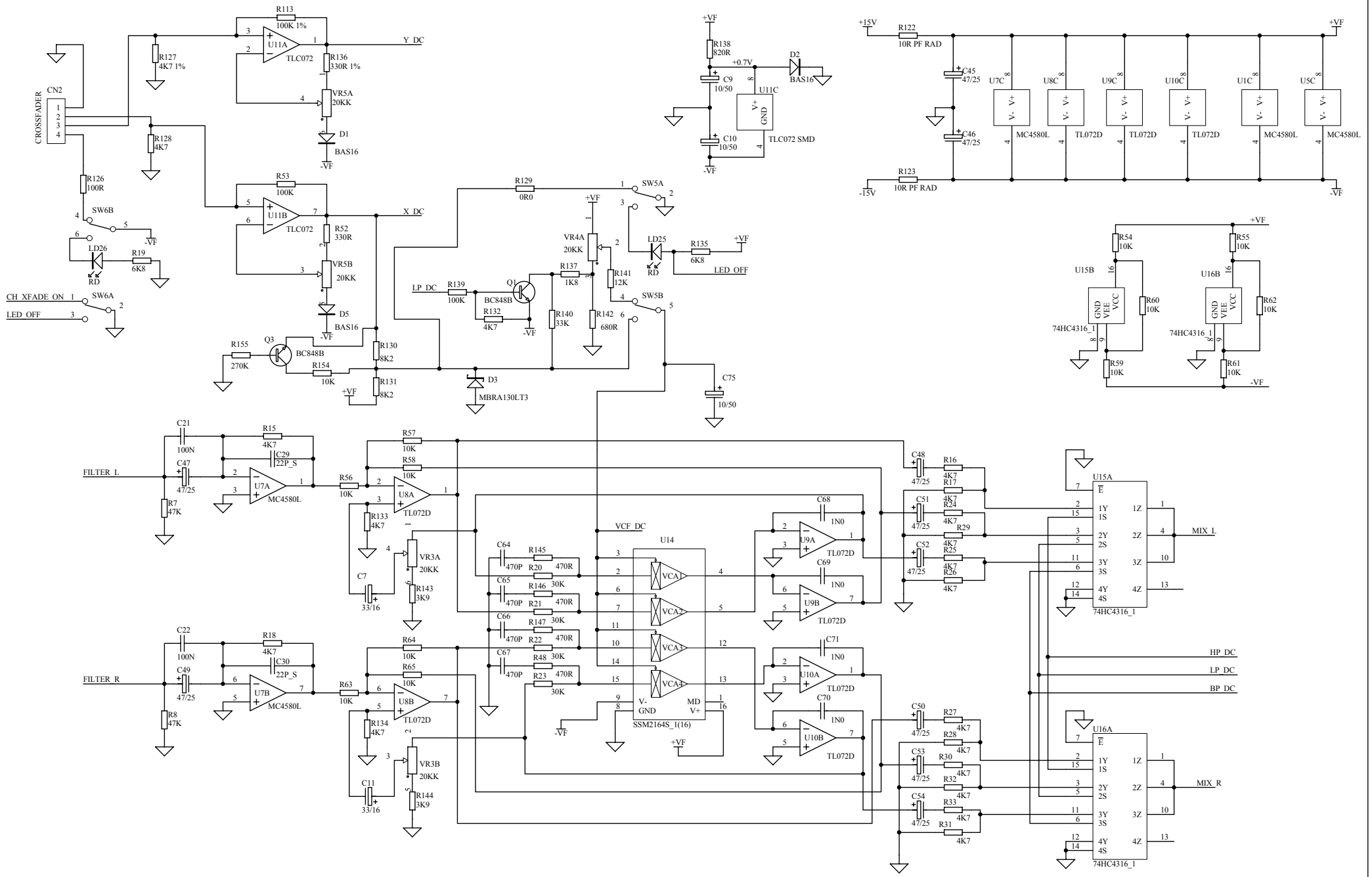

ALLEN&HEATH

Kernick Industrial Estate,
Penryn, Cornwall,
England. TR10 9LU
Tel: +44 (0)1326 372070
Fax: +44 (0)1326 370153

ISSUE	BY	DATE	CHK BY
1	ARJ	21-06-07	

BRKT	BRKT	BRKT
VR3C	VR4B	VR5C
<input type="checkbox"/>	<input type="checkbox"/>	<input type="checkbox"/>

FILE: AG6992_2 Sheet_2.Sch

TITLE:	XONE 42 MASTER
PAGE:	
DRG No:	C6992
ISSUE:	2
SHEET:	2 OF 3

* All parts to be RoHS Compliant *

PRINTED: 13:49:04 12-Nov-2007

e
d
c
b
a

A B C D E F G H

FILTER SWITCH LOGIC

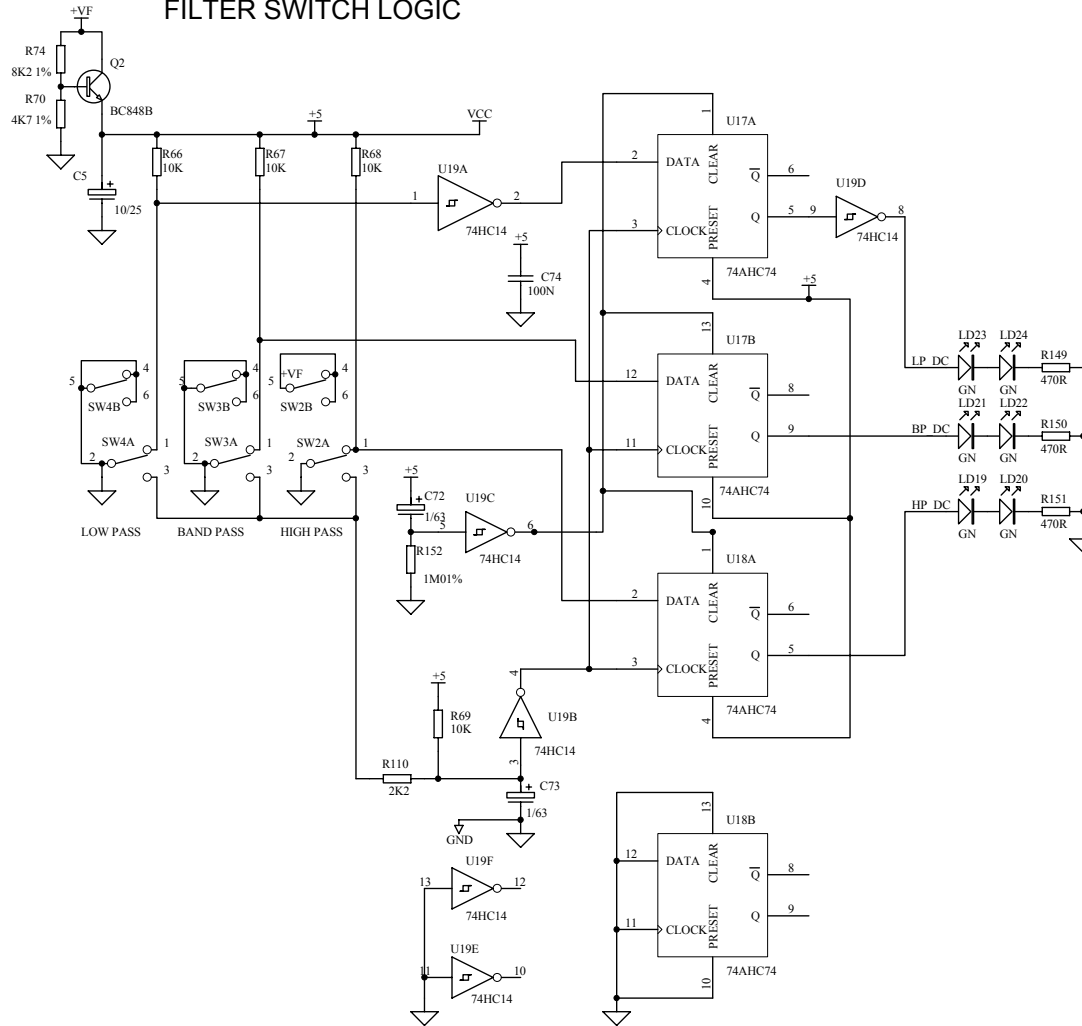

ALLEN&HEATH

Kernick Industrial Estate,
Penryn, Cornwall,
England. TR10 9LU
Tel: +44 (0)1326 372070
Fax: +44 (0)1326 370153

ISSUE	BY	DATE	CHK BY

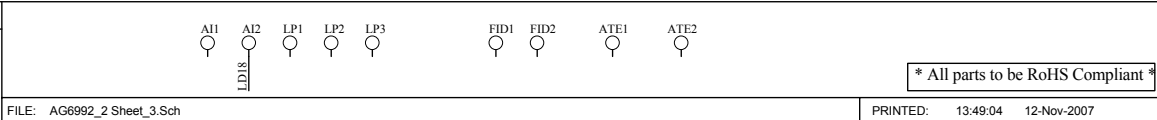

* All parts to be RoHS Compliant *

FILE: AG6992_2 Sheet_3.Sch

PRINTED: 13:49:04 12-Nov-2007

TITLE: XONE 42 MASTER

PAGE:

DRG No: C6992 ISSUE: 2 SHEET: 3 OF 3

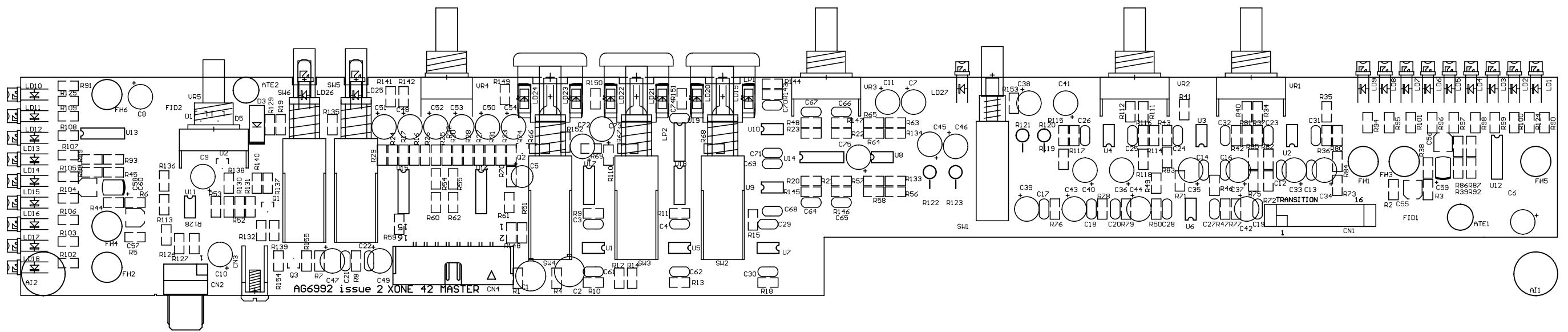

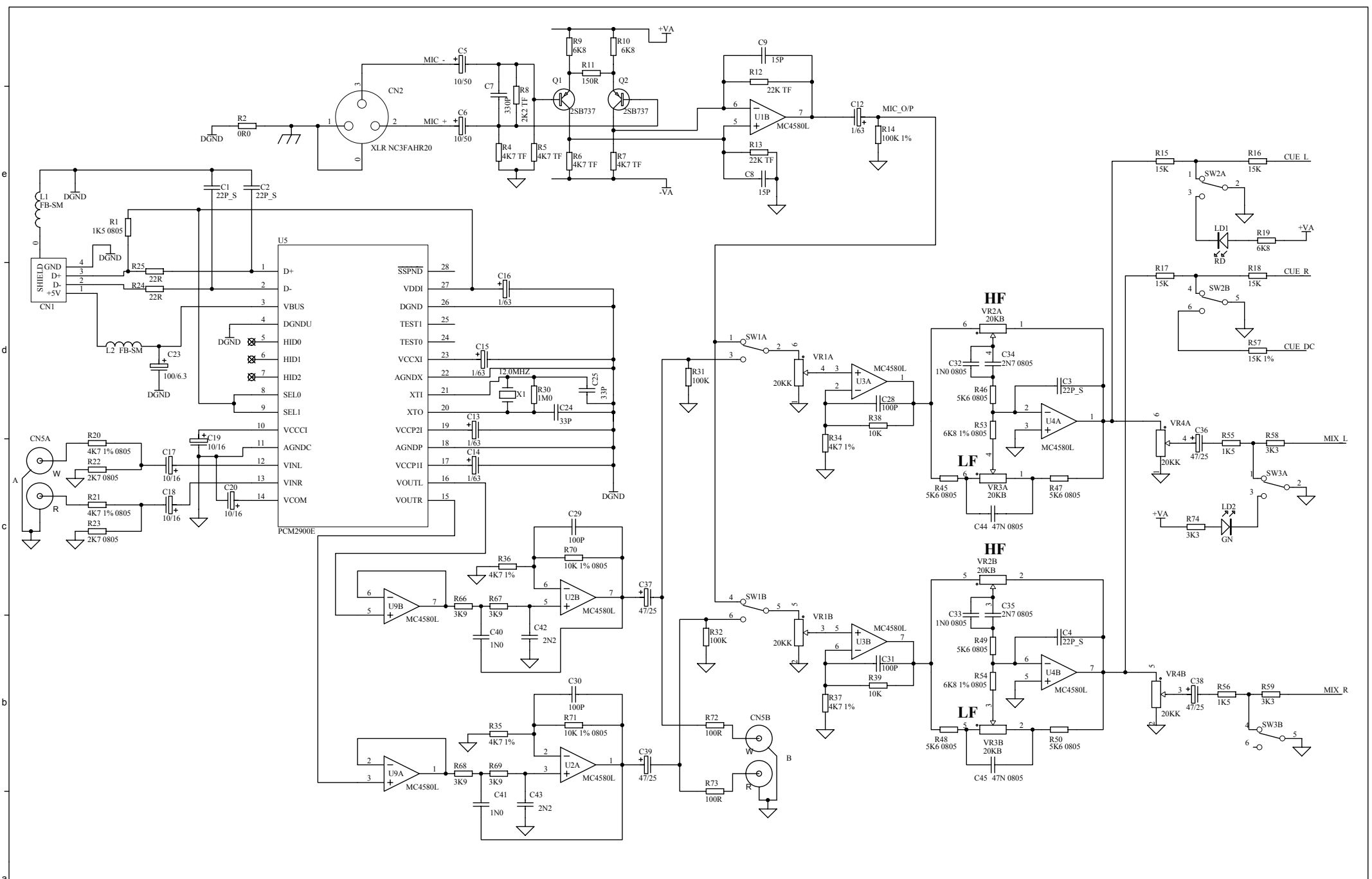

ALLEN&HEATH
 Kernick Industrial Estate,
 Penryn, Cornwall,
 England. TR10 9LU
 Tel: +44 (0)1326 372070
 Fax: +44 (0)1326 370153

ISSUE	BY	DATE	CHK BY
1	ARJ	27-06-07	

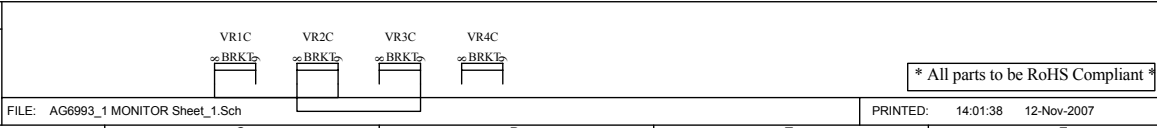

TITLE: **XONE 42 MONITOR**
 PAGE:
 DRG No: **C6993** ISSUE: 1 SHEET: 1 OF 2

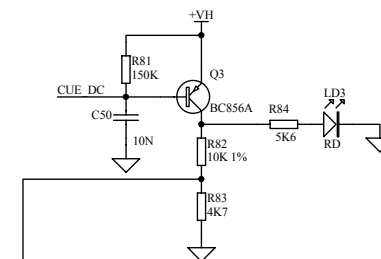
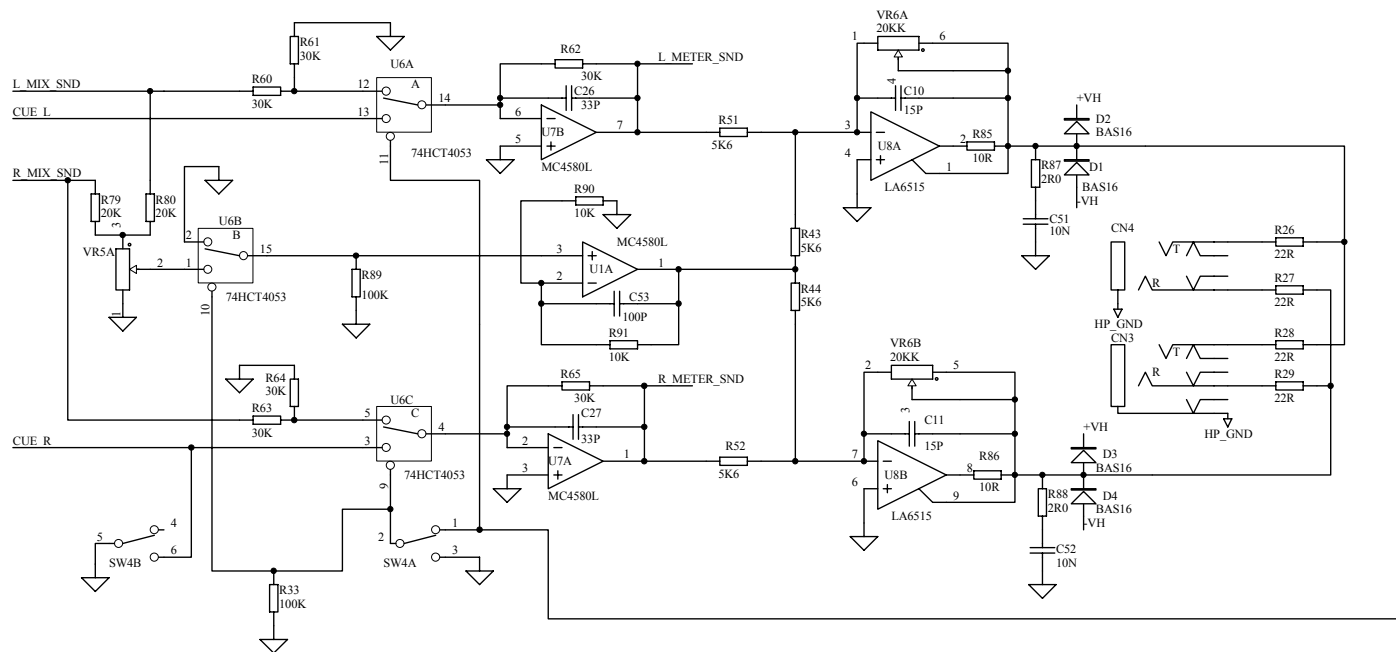
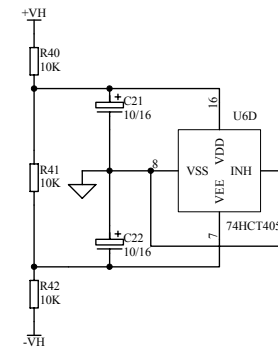
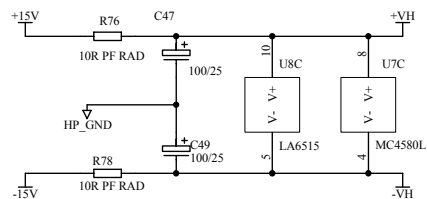
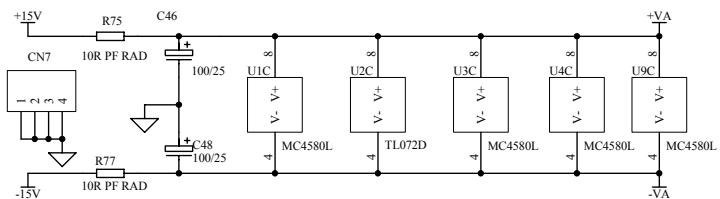
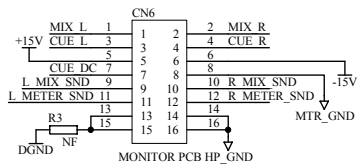

ALLEN&HEATH

Kernick Industrial Estate,
Penryn, Cornwall,
England. TR10 9LU
Tel: +44 (0)1326 372070
Fax: +44 (0)1326 370153

ISSUE	BY	DATE	CHK BY
1	ARJ	27-06-07	

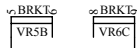

* All parts to be RoHS Compliant *

FILE: AG6993_1 MONITOR Sheet_2_Sch

PRINTED: 14:01:38 12-Nov-2007

TITLE: XONE 42 MONITOR

PAGE:

DRG No: C6993 ISSUE: 1 SHEET: 2 OF 2

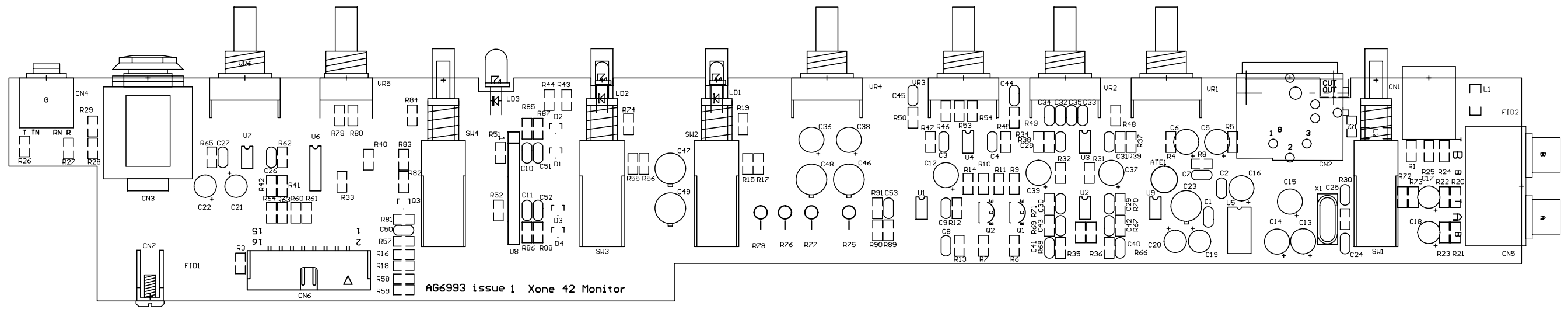

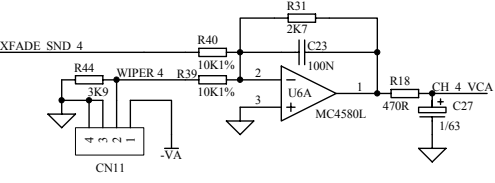
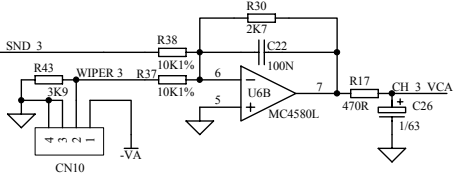
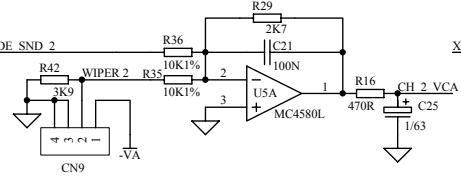
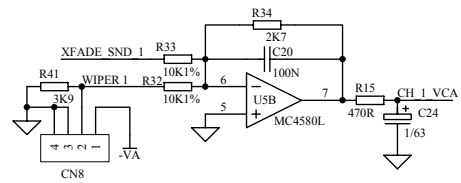
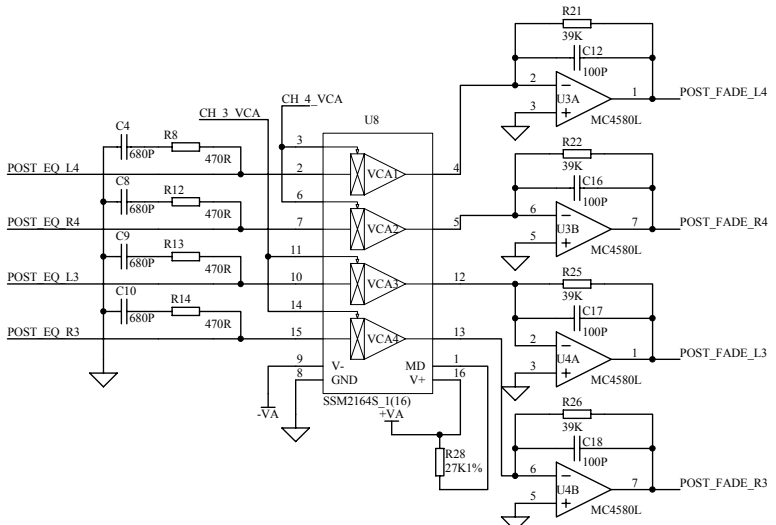
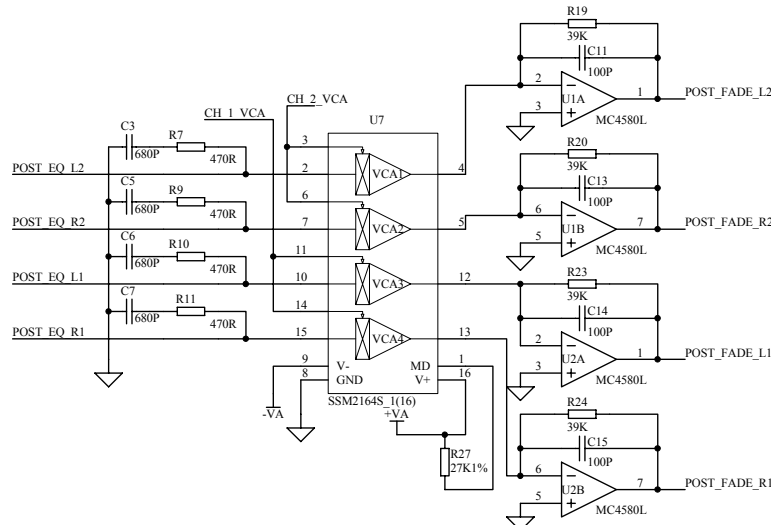
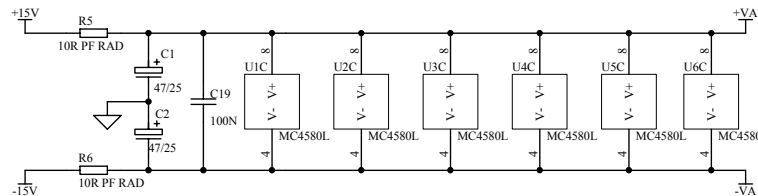
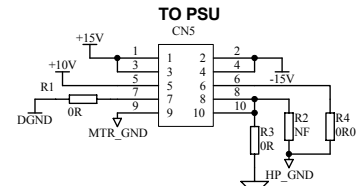
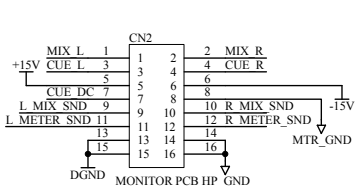
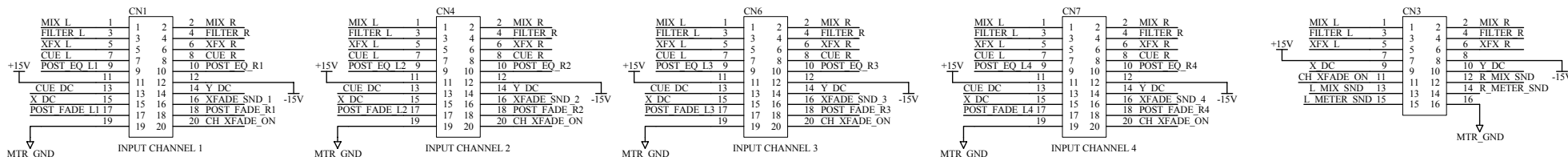

ALLEN&HEATH

Kernick Industrial Estate,
Penryn, Cornwall,
England. TR10 9LU
Tel: +44 (0)1326 372070
Fax: +44 (0)1326 370153

ISSUE	BY	DATE	CHK BY
1	ARJ	27-06-07	

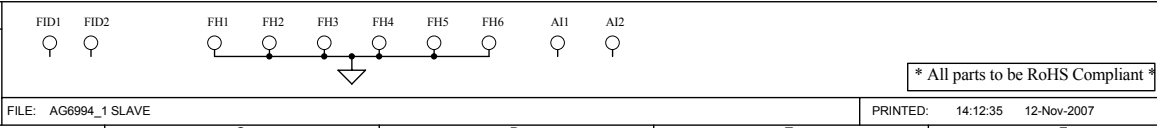

TITLE: **XONE 42 SLAVE**
PAGE:
* All parts to be RoHS Compliant *
PRINTED: 14:12:35 12-Nov-2007
DRG No: **C6994** ISSUE: 1 SHEET: 1 OF 1

FILE: AG6994_1 SLAVE

PRINTED: 14:12:35 12-Nov-2007

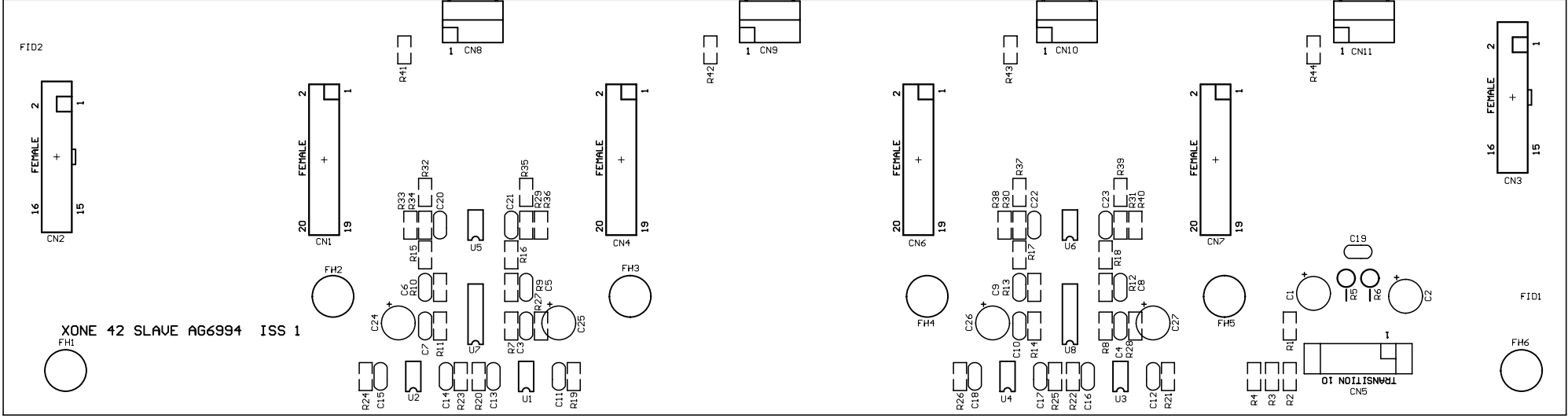

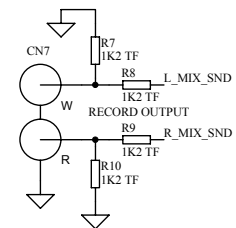
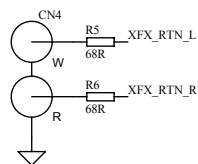
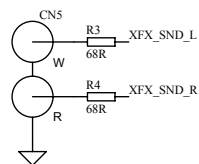
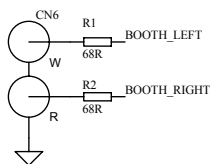
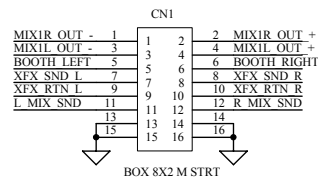
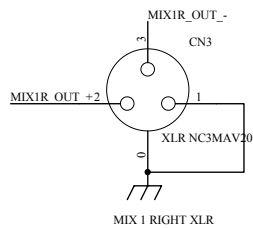
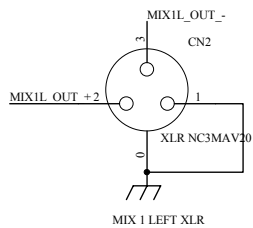

ALLEN&HEATH

Kernick Industrial Estate,
Penryn, Cornwall,
England. TR10 9LU
Tel: +44 (0)1326 372070
Fax: +44 (0)1326 370153

ISSUE	BY	DATE	CHK BY
1	ARJ	27-06-07	

FID1 FID2



FILE: AG6995_1 CONNECTOR.Sch

* All parts to be RoHS Compliant *

PRINTED: 14:09:25 12-Nov-2007

TITLE: XONE 42 REAR CONN

PAGE:

DRG No: C6995 ISSUE: 1 SHEET: 1 OF 1

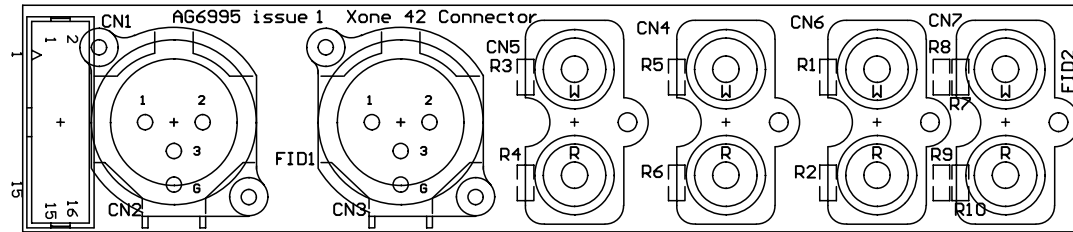

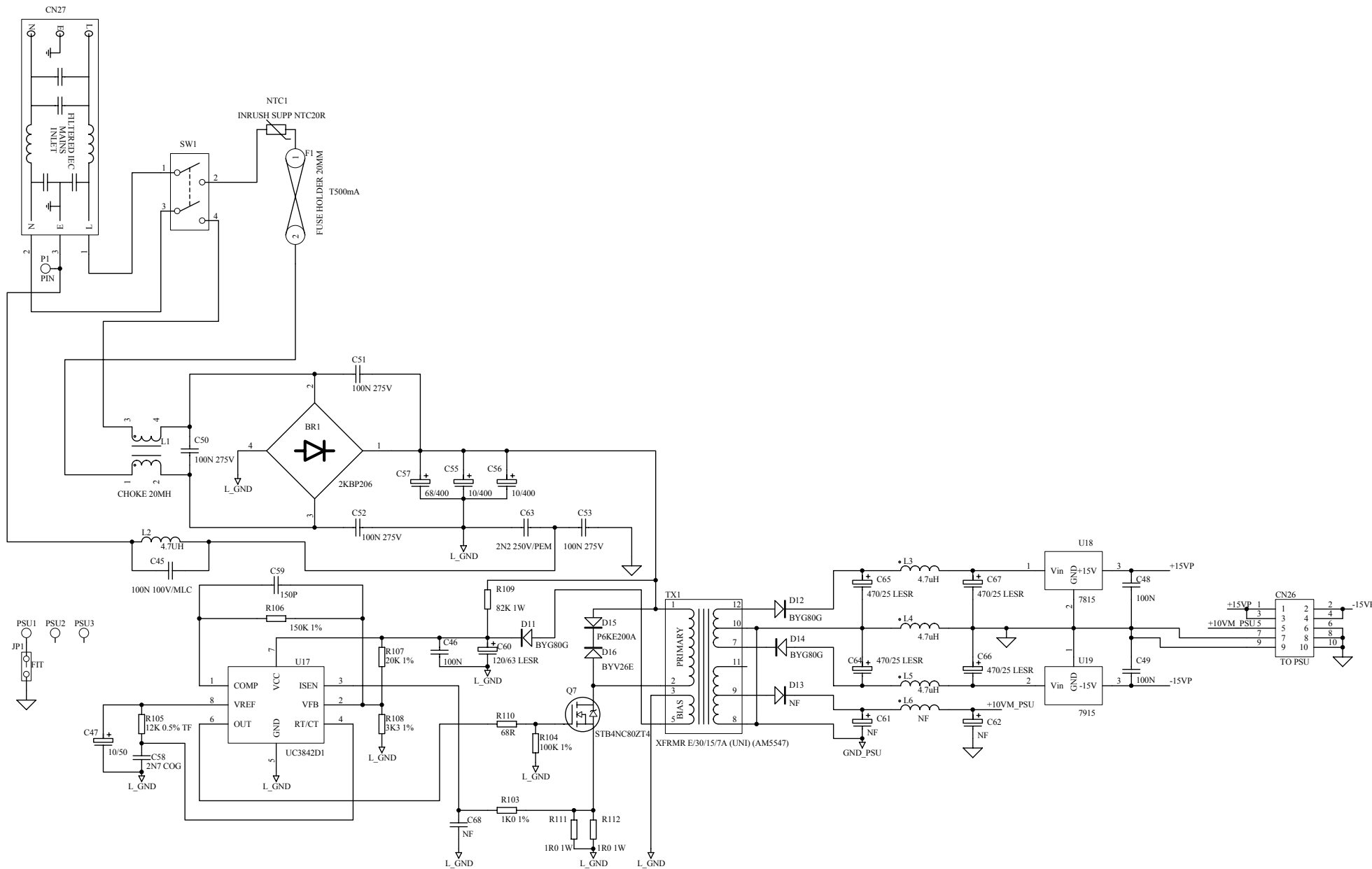

ALLEN&HEATH

Kernick Industrial Estate,
Penryn, Cornwall,
England. TR10 9LU
Tel: +44 (0)8707 556250
Fax: +44 (0)8707 556251

ISSUE	BY	DATE	CHK BY
3.1	ARJ	24-11-05	

FID1 FID2 FID3 FID4 A11 A12

FILE: AG5609 PSU_MAINS ISSUE 3.1.Sch

PRINTED: 12:00:59 12-Nov-2007

TITLE: XONE 42 POWER SUPPLY

PAGE:

DRG No: C5609 ISSUE: 3.2 SHEET: 1 OF 1

A I B C D E F G H

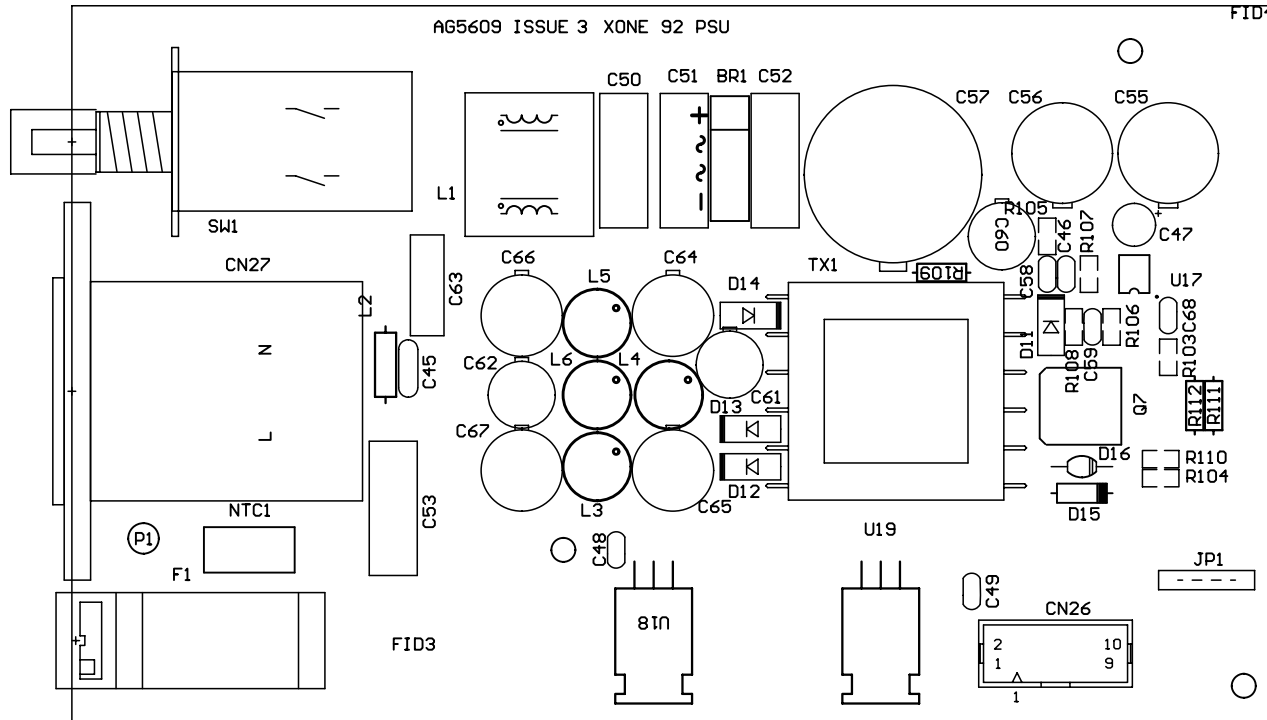

Xone:42- Surface Parts Identification

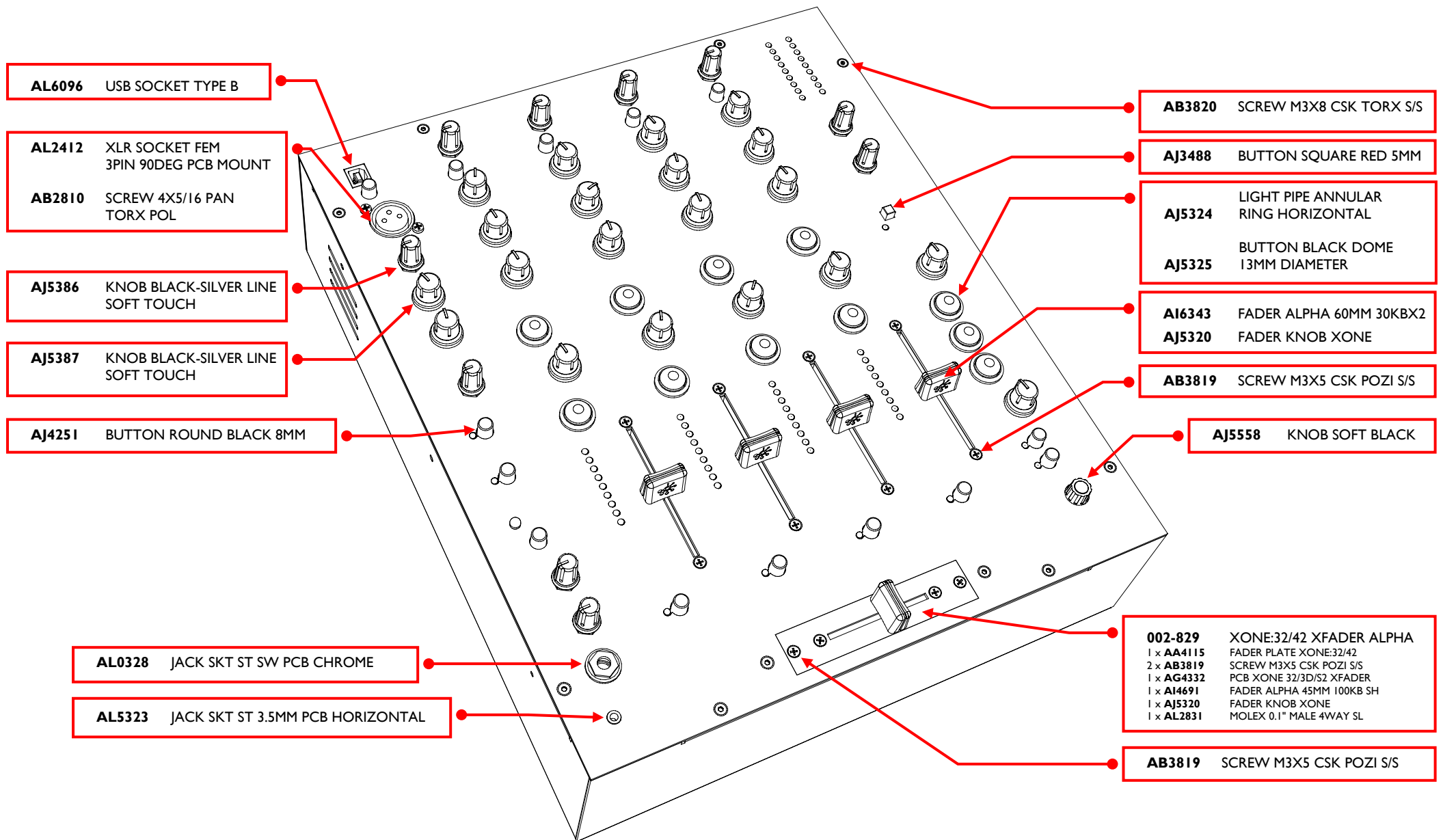

Xone:42 - Internal Parts Identification

