

ALLEN & HEATH

 **XONE:62**
P R O F E S S I O N A L D J M I X E R

SERVICE MANUAL

For XONE:62 VERSION 1 and VERSION 2

Publication AP3842

Allen & Heath Technical Support

This service manual provides technical information for servicing the **XONE:62**. It refers to both the original (VERSION 1) and the revised (VERSION 2) model **XONE:62**. Whilst we believe the information presented to be reliable we do not assume responsibility for inaccuracies. We also reserve the right to make changes in the interest of further product development.

For further technical support please contact us at Allen & Heath. The contact details are printed below. To help us provide the most efficient service please quote the console serial number in any communication regarding this product. Our Internet site provides further information on our full product range as well as contact details for our distribution network.



This product complies with the European Electromagnetic Compatibility directives 89/336/EEC & 92/31/EEC and the European Low Voltage Directives 73/23/EEC & 93/68/EEC.

This product has been tested to EN55103 Parts 1 & 2 1996 for use in Environments E1, E2, E3, and E4 to demonstrate compliance with the protection requirements in the European EMC directive 89/336/EEC. During some tests the specified performance figures of the product were affected. This is considered permissible and the product has been passed as acceptable for its intended use. Allen & Heath has a strict policy of ensuring all products are tested to the latest safety and EMC standards. Customers requiring more information about EMC and safety issues can contact Allen & Heath.

NOTE: Any changes or modifications to the console not approved by Allen & Heath could void the compliance of the console and therefore the users authority to operate it.

XONE:62 Service Manual AP3842 Issue 3

Copyright © 2004 Allen & Heath. All rights reserved

ALLEN & HEATH

Kernick Industrial Estate, Penryn, Cornwall, TR10 9LU, UK

Web: <http://www.allen-heath.com>

Email: sales@allen-heath.com

support@allen-heath.com

spares@allen-heath.com

Important Safety Instructions

WARNINGS - Read the following before proceeding :



ATTENTION: RISQUE DE CHOC ELECTRIQUE – NE PAS OUVRIR

- Read instructions:** Retain these safety and operating instructions for future reference. Adhere to all warnings printed here and on the console.
- Do not remove covers:** Operate the console with its covers correctly fitted. Disconnect mains power by unplugging the power cord if the covers need to be removed for setting internal options. This work should be carried out by competent technical personnel only.
- Power sources:** Connect the console to a mains power only of the type described in the User Guide and marked on the rear panel. Use the power cord with sealed mains plug appropriate for your local mains supply as provided with the console. If the provided plug does not fit into your outlet consult your service agent for assistance.
- Power cord routing:** Route the power cord so that it is not likely to be walked on, stretched or pinched by items placed upon or against it.
- Grounding:** Do not defeat the grounding and polarisation means of the power cord plug. Do not remove or tamper with the ground connection in the power cord.



WARNING: This equipment must be earthed.

- Water and moisture:** To reduce the risk of fire or electric shock do not expose the console to rain or moisture or use it in damp or wet conditions. Do not place containers of liquids on it which might spill into any openings.
- Ventilation:** Do not obstruct the ventilation slots or position the console where the air flow required for ventilation is impeded. If the console is to be operated in a rack unit or flightcase ensure that it is constructed to allow adequate ventilation.
- Heat and vibration:** Do not locate the console in a place subject to excessive heat or direct sunlight as this could be a fire hazard. Locate the console away from any equipment which produces heat or causes excessive vibration.
- Servicing:** Switch off the equipment and unplug the power cord immediately if it is exposed to moisture, spilled liquid, objects fallen into the openings, the power cord or plug become damaged, during lightening storms, or if smoke, odour or noise is noticed.
- Installation:** Install the console in accordance with the instructions printed in the User Guide. Do not connect the output of power amplifiers directly to the console. Use audio connectors and plugs only for their intended purpose.



Important Mains plug wiring instructions.

The console is supplied with a moulded mains plug fitted to the AC mains power lead. Follow the instructions below if the mains plug has to be replaced.

The wires in the mains lead are coloured in accordance with the following code:

TERMINAL		WIRE COLOUR	
		European	USA/Canada
L	LIVE	BROWN	BLACK
N	NEUTRAL	BLUE	WHITE
E	EARTH GND	GREEN & YELLOW	GREEN

The wire which is coloured Green and Yellow must be connected to the terminal in the plug which is marked with the letter E or with the Earth symbol. **This appliance must be earthed.**

The wire which is coloured Blue must be connected to the terminal in the plug which is marked with the letter N.

The wire which is coloured Brown must be connected to the terminal in the plug which is marked with the letter L.

Ensure that these colour codes are followed carefully in the event of the plug being changed.

Precautions

- Damage :** To prevent damage to the controls and cosmetics avoid placing heavy objects on the control surface, scratching the surface with sharp objects, or rough handling and vibration.
- Environment :** Protect from excessive dirt, dust, heat and vibration when operating, servicing and storing. Avoid tobacco ash, smoke, drinks spillage, and exposure to rain and moisture. If the console becomes wet, switch off and remove mains power immediately. Allow to dry out thoroughly before using again.
- Cleaning :** Avoid the use of chemicals, abrasives or solvents. The control panel is best cleaned with a soft brush and dry lint-free cloth. The faders, switches and potentiometers are lubricated for life. The use of electrical lubricants on these parts is not recommended.
- Transporting :** The console may be transported as a free-standing unit or mounted in a rack or flightcase. Ensure that the connector pod is secured in place with the locking screws fitted to prevent movement. Protect the controls from damage during transit. The faders are best positioned at the top of their travel if the console is transported without a suitable flightcase, rack or carton. Use adequate packing if you need to ship the unit.

Contents

Important Safety Instructions	3	Block Diagram VERSION 1	D1
Mains Plug Wiring Instructions	4	Block Diagram VERSION 2	D2
Precautions	4	INPUT PCB	D3
Welcome to the XONE:62	6	INPUT 1-2 Circuit	D4
VERSION 1 and VERSION 2	7	INPUT 3-6 Circuit	D5
Order Codes.....	7	LEFT PCB	D6
Panel Drawings VERSION 1	8	LEFT Circuit	D7
Panel Drawings VERSION 2	9	RIGHT PCB	D8
Cue Sheet VERSION 1	10	RIGHT Circuit.....	D9
Cue Sheet VERSION 2.....	11	ROTARY OUTPUT	D10
Specifications	12	CROSSFADE PCB.....	D11
Optional Rack Ears	14	CROSSFADE Circuit Sheet 1	D12
Connecting Mains Power.....	15	CROSSFADE Circuit Sheet 2	D13
Earthing	15	CONNECTOR PCB.....	D14
Plugging up the System.....	16	CONNECTOR Circuit.....	D15
Cable Wiring.....	17	PSU PCB and Circuit VERSION 2	D16
Replacing the Crossfader	18	MAINS PCB and Circuit VERSION 2	D17
Tips and Troubleshooting.....	19	PSU PCB VERSION 1	D18
Gain and Operating Levels	20	PSU Circuit VERSION 1	D19

Welcome to the XONE:62

From the User Guide:

The Allen & Heath **XONE:62** presents a unique combination of performance tools for the professional DJ in a stylish and solidly built club format. Above all, it features sound quality second to none. **XONE:62** has been designed and constructed using the same rigorous standards we apply to our large format professional consoles used and respected by top engineers throughout the world.

XONE:62 provides **6 dual stereo channels**, with A and B inputs on each, two offering mic inputs, adding up to a massive 10 stereo and 2 microphone inputs. A full range of connectors means that you can connect up to 4 turntables, 2 mics, CD players, MD players, drum machines, samplers, and pretty much anything else you might want to bring into the mix.

The more bands of EQ you have, the more creative you can get with your mix. That is why we give you **4 EQ controls** rather than the usual 3. Each band has a safe +6dB boost and a massive -26dB of cut, enough to creatively shape your sound well beyond normal EQ range, and without overloading your system. Punch the effect in or out using the EQ on switch.

Channels 3 to 6 can be assigned to either side of the high spec Penny & Giles **VCA crossfader**. This controls the audio using a DC voltage meaning that it can take a huge amount of punishment without the bangs and crackles that inevitably creep in on regular audio faders. It is easily removable from the top panel for quick replacement should it become worn. The curve can be switched to either dipped response, ideal for seamless beat mixing, or to dipless better suited to scratch or cut mixing.

Unique to **XONE**, two stereo state variable **Voltage Controlled Filters** provide the DJ with a new level of live performance creativity. These are very similar to those found on classic analogue synths but benefit from modern, quiet and stable technology. Use these to sweep the sound by accentuating or cutting frequencies from 100Hz to 20kHz. The 3 filter types HPF, BPF and LPF can be combined to create many more amazing effects. A large Resonance control changes the 'Q' or sharpness of the filter effect from subtle to extreme. Each VCF has its own in/out switch.

Combined with the extensive output and monitoring features, colour coded indicators, stylish layout and clear graphics visible in all lighting situations, you have an unbeatable performance console equally at home in dance clubs, home set-ups, live venues, and on the road.

- 6 Dual stereo inputs, 2 with mic inputs
- RIAA preamps for up to 4 turntables
- A/B input selectors with 2 colour indicators
- Stereo aux send with pre/post switching
- 4 Band asymmetric EQ with extended cut
- EQ in/out switches to defeat the effect
- Large illuminated cue switches
- 4 led 3 colour channel meters
- Removable VCA crossfader
- Crossfader balance and aux send
- Dual stereo analogue VCF effects
- 3 Filter modes combine for more effects
- Independent frequency sweep controls
- Resonance control for subtle or wild effects
- Filter switches to punch the effect in or out
- Large blue leds indicate filter status
- Powerful headphones monitor with auto cue
- Headphones split cue and mix/aux monitoring
- Stereo music only booth monitor output
- Booth mono and mute switching
- 12 led 3 colour main meters with peak hold
- Balanced +4dBu XLR stereo mix output
- Mono sum output for zone feed or light effects
- Pre-fade recording output
- Soft touch controls gentle on the fingers

VERSION 1 and VERSION 2 Model Differences

There are minor changes between the original **XONE:62** and the revised model which replaced it in October 2000. This service manual covers both models. Spares and support are available for both models. When servicing or ordering spare parts for a **XONE:62** first check which model it is.

The original model is referred to as **VERSION 1**. Its order code is XONE:62/. Its key identifiers are:

Serial number sequence 020000

Stainless steel panel. Linear MIX master fader.

The newer model is referred to as **VERSION 2**. Its order code is XONE2:62/. Its key identifiers are:

Serial number sequence 030000

Painted silver panel. Rotary MIX master control.

The following is a summary of the differences introduced on VERSION 2:

Styling The original stainless steel finish is replaced with a new textured silver paint. Several knob and pushbutton types have been changed to further co-ordinate the styling. There are minor changes to the graphics.

Master Level Controls The original MIX master linear fader has been replaced with a rotary master control.

Crossfader The new high grade Penny & Giles fader is fitted instead of the original Alps version. These are not interchangeable with VERSION 1.

Power Supply The power supply assembly was changed to improve production efficiency.

The circuit information is mostly identical between the two models. Differences are noted on the diagrams.

Order Codes

XONE:62 VERSION 1	not available
XONE:62 VERSION 2	XONE2:62/* (* = voltage)
Rack Ears for plinth mounting	XONE2:62-RK
Rack Ears for 19" rack mounting	XONE2:62-RK19
Crossfader Assembly VERSION 1	002-718 (Alps)
Crossfader Assembly VERSION 2	002-719 (P&G)
Stereo Fader Assembly	002-684
User Manual VERSION 1	AP3754
User Manual VERSION 2	AP4145
Service Manual for both versions	AP3842 (from issue 2)

VERSION 1

ALLEN & HEATH XONE:62 PROFESSIONAL P.J. MIXER

CAUTION
AVIS: RISQUE DE CHOC ELECTRIQUE - NE PAS OUVRIIR.
REFER TO USER GUIDE BEFORE CONNECTING SUPPLY.
NO USER SERVICEABLE PARTS INSIDE.
REFER SERVICE TO QUALIFIED SERVICE PERSONNEL.
TO REDUCE THE RISK OF FIRE OR ELECTRIC SHOCK,
DO NOT EXPOSE THIS APPARATUS TO RAIN OR MOISTURE.

USER OPTIONS
WARNING - THIS APPARATUS MUST BE EARTHED.

AC MAINS IN - FUSE SUPPLY VOLTAGE RANGE:
100 - 240V - 1500mA 250V 20mm
47-63Hz - 50W MAX

MONO OUT BOOTH L, AUX OUT L, CLEAN FEED L, CLEAN FEED R

RECORD OUT L, R

MIX OUT RIGHT, LEFT

INPUTS 3-6 PHONO - LINE L, R

INPUT 2 MIC, LINE L/M, R

INPUT 1 MIC, LINE L/M, R

WARNING FOR CONTINUED PROTECTION AGAINST RISK OF FIRE:
REPLACE FUSE WITH SAME TYPE AND RATING.
ATTENTION: REMPLACER LE FUSIBLE AVEC UNES MEMES CARACTERISTIQUES

Made in the UK by ALLEN & HEATH

ALLEN & HEATH XONE:62 PROFESSIONAL P.J. MIXER

1 - MIC - 2 3 - MUSIC - 4 5 - 6

EQ ON EQ ON EQ ON EQ ON EQ ON EQ ON

EQ HI, MID 1, MID 2, LO

GAIN MIN, MAX

MIC Line Phono Line

PRE PRE

MONITOR L, R

PRG - SPLIT CUE +8, +5, +3, +1, 0, -1, -3, -5, -7, -10, -15, -20

CUE CUE

SPLIT CUE SPLIT CUE

AUX AUX

MONO MONO

BOOTH MONITOR (Clearfeed)

MUTE MUTE

PAN PAN

XFADE XFADE

RESONANCE RESONANCE

MILD MILD

WILD WILD

HPF HPF

BPF BPF

LPF LPF

VCF RESPONSE VCF RESPONSE

MIX MIX

VCF 100Hz, 20kHz

FILTER FILTER

X X

Y Y

VCA VCA

PHONES PHONES

VERSION 2

XONE:62
PROFESSIONAL DJ MIXER

CAUTION
AVIS: RISQUE DE CHOC ELECTRIQUE - NE PAS OUVRIE.
REFER TO USER GUIDE BEFORE CONNECTING SUPPLY.
NO USER SERVICEABLE PARTS INSIDE.
REFER SERVICE TO QUALIFIED SERVICE PERSONNEL.
TO REDUCE THE RISK OF FIRE OR ELECTRIC SHOCK
DO NOT EXPOSE THIS APPARATUS TO RAIN OR MOISTURE.

USER
WARNING - THIS APPARATUS MUST BE EARTHED.

AC MAINS IN ~

FUSE
SERIAL No: [REDACTED]
SUPPLY VOLTAGE RANGE:
100 - 240V ~
47-63Hz ~ 30W MAX
100 - 240V ~ 1500mA 250V 20mm

WARNINGS: FOR CONTINUED PROTECTION AGAINST RISK OF FIRE
REPLACE FUSE WITH SAME TYPE AND RATING
ATTENTION: REMPLACER LE FUSIBLE AVEC UN DES MEMES CARACTERISTIQUES.

MONO OUT
BOOTH L R
AUX-OUT L R
CLEAN FEED

RECORD OUT
L R
CLEAN FEED -10dBV

PHONO - LINE
L R
INPUT 6

PHONO - LINE
L R
INPUT 5

PHONO - LINE
L R
INPUT 4

PHONO - LINE
L R
INPUT 3

MIX OUT
RIGHT LEFT
PH2=+

INPUT 2
L/M R

INPUT 1
L/M R

ALLEN&HEATH
Made in the UK by ALLEN & HEATH

ALLEN&HEATH

XONE:62
PROFESSIONAL DJ MIXER

MONITOR L R
+8
+5
+3
+1
0
-1
-3
-5
-7
-10
-15
-20
CUE PRG
L SPLIT

AUX PRE
GAIN
HI
MID 1
MID 2
LO
EQ ON

1 MIC 2 3 4 MUSIC 5 6

CUE
PK
+6
0
-15

XFAD
ON
X
Y
L
R

XFAD
ON
X
Y
L
R

XFAD
ON
X
Y
L
R

XFAD
ON
X
Y
L
R

XFAD
ON
X
Y
L
R

XFAD
ON
X
Y
L
R

MASTER
MAIN MIX

RESONANCE
MILD WILD

HPF
BPF
LPF

VCF RESPONSE

PHONES

Crossfader By
Perry+Giles

VCA

VCF
100Hz 20kHz
ON

FILTER

XONE:62 VERSION 1 - CUE SHEET

Photocopy and use to log your console settings

1	2	3	4	5	6
MIC	MIC	PHONO	PHONO	PHONO	PHONO
LINE	LINE	LINE	LINE	LINE	LINE

The diagram illustrates the control panel of the XONE:62 mixer, organized into six channels (1-6) and a master section. Channel 1 is labeled 'MIC' and channels 2-6 are labeled 'PHONO'. Each channel includes an AUX knob with a PRE button, a GAIN knob with MIN and MAX markings, and four EQ knobs (HI, MID 1, MID 2, LO) with frequency markings. Below the EQ knobs is an EQ ON button. Channel 2 is specifically labeled '1 - MIC - 2' and channel 5 is labeled '4 - MUSIC - 5'. The master section includes a large volume knob, a CUE MONITOR section with L and R sliders and a CUE button, a PAN knob, an XFADE knob, and a RESONANCE knob. There are also buttons for SPLIT CUE, AUX, MONO, and MUTE. The VCF section features two VCF knobs with 100Hz and 20kHz markings, FILTER buttons, and a CURVE button. The Allen & Heath logo is prominently displayed in the top right corner.

XONE:464 VERSION 2 - CUE SHEET

Photocopy and use to log your console settings

1	2	3	4	5	6
MIC	MIC	PHONO	PHONO	PHONO	PHONO
LINE	LINE	LINE	LINE	LINE	LINE

ALLEN&HEATH

MONITOR

L R

+8
+5
+3
0
-1
-3
-5
-7
-10
-15
-20

CUE PRG
L SPLIT

XONE:62
PROFESSIONAL DJ MIXER

AUX PRE

Phono Line

GAIN

HI

MID 1

MID 2

LO

EQ ON

1 MIC 2 3 4 MUSIC 5 6

CUE

PK

XFADE

PAN

RESONANCE

HPF

BPF

LPF

VCF RESPONSE

FILTER

VCF

100Hz 20kHz

VCA

PHONES

MASTER

MAIN MIX

Crossfader By **Perry+Glas**

Specifications

0dBu = 0.775 Volts rms, +4dBu = 1.23V rms
316mV rms

0dBV = 1 Volt rms, -10dBV =

Max output level	XLR	+26dBu into >2k ohm	Ch meters	Peak reading 4 led
	TRS	+21dBu into >2k ohm		-16, 0, +6, +12 (PK)
Headroom	RCA	+15dBu into >10k ohm	Main meters	Peak reading 12 led
	Channels	+21dB		-20 to +8
Freq response	Mix to output	+23dB	Mic EQ	4-Band +/-15dB
		+0/-1dB 20Hz to 40kHz		100, 250, 2.5k, 10kHz
Distortion		< 0.006% THD+noise @1kHz	Music EQ	4-Band +6 / -26dB
Crosstalk		< 90dB Channel shutoff @1kHz		100, 250, 2.5k, 10kHz
MIC EIN	22-22kHz-128dB	150 ohm source	Ch fader	60mm stereo
Residual noise	XLR	-90dBu (-94dB S/N)	Mix fader	100mm stereo or rotary
	TRS	-84dBu (-84dB S/N)	Crossfader	45mm stereo VCA
	RCA	-92dBu (-84dB S/N)		Replaceable
Mix noise	XLR	-86dBu (-90dB S/N)	Filters	Dual stereo VCF
	TRS	-83dBu (-83dB S/N)		Analogue
	RCA	-91dBu (-83dB S/N)	Panel	Stainless steel

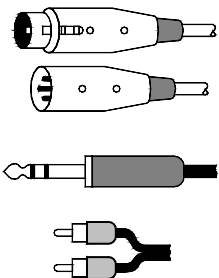

Connector Types

XLR male and female connectors : Pin 2 = hot (+) Pin 3 = cold (-) Pin 1 = GND
 TRS input and output connectors : Tip = hot (+) Ring = cold (-) Sleeve = GND
 RCA PHONO pin connectors

Input Connections

	Type	Impedance	Sensitivity
CH1,2 IN (Mic)	Balanced XLR female	2k ohm	-45 to -15dBu
(Stereo Line)	Unbalanced TRS jack	>10k ohm	-15 to +15dBu
CH3,4,5,6 (Phono)	RCA phono RIAA	47kohm/330pF	2 to 100mV
(Stereo Line)	RCA phono	>10k ohm	-10 to +10dBu

Output Connections

	Type	Impedance	Level
MIX OUT L,R (XLR)	Balanced XLR male	<75 ohm	
+4dBu			
RECORD OUT	RCA phono	<600 ohm	-10dBV
MONO OUT	Impedance balanced TRS jack	<600 ohm	-2dBu
AUX OUT L,R	Impedance balanced TRS jack	<75 ohm	-2dBu
BOOTH OUT	Impedance balanced TRS jack	<75 ohm	-2dBu
HEADPHONES	Tip = L Ring = R	30 to 600 ohm recommended	

Power Supply

Internal switch mode power unit with auto sensing mains input.

MAINS IN socket IEC 3 pin

Power lead Country dependent with moulded mains plug supplied

AC mains 100 to 240V AC @ 50/60Hz

Consumption 30W max

Mains fuse rating 100-240V AC T500mA 20mm

Dimensions and Weights

The console is fitted with rubber feet for desktop operation. An optional screw on rack ear kit is available for rack or plinth mounting.

	Width	Height	Depth	Weight
Desktop	320 mm (12.6")	105 mm (4.1")	358 mm (14.1")	5 kg (11 lbs)
Rack ears fitted	370 mm (14.6")	105 mm (4.1")	358 mm (14.1")	
Packed	475 mm (18.7")	210 mm (8.3")	395 mm (15.6")	5.5 kg (12 lbs)

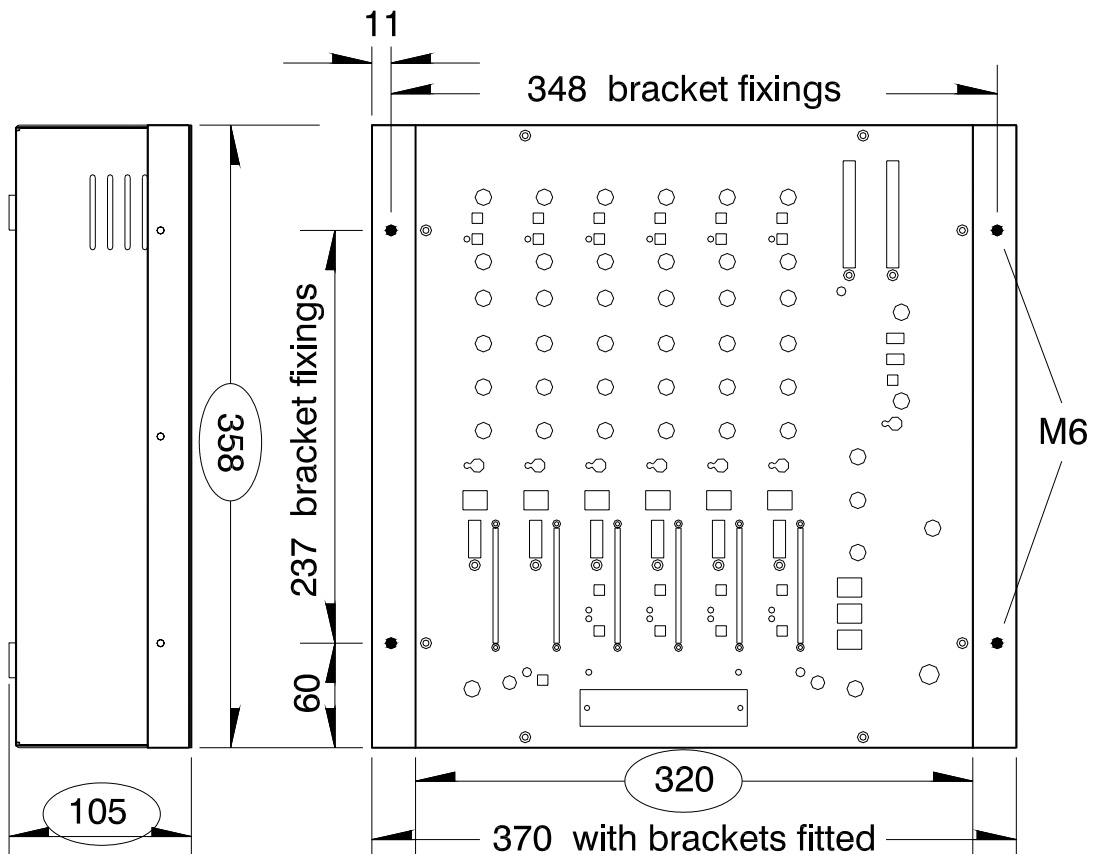



Optional Rack Ears

Allows permanent fixing in a plinth or rack system. Ears bolt on to the sides of console. Fix in place using M6 screws or bolts. Contact your Allen & Heath agent for further information.

Order code: XONE2:62-RK or XONE2:62-RK19

- 

6x M4x8 PAN POZI SCREWS
- 

4x M6x16 PAN SLOT SCREWS
- 

4x M6 CUP WASHERS

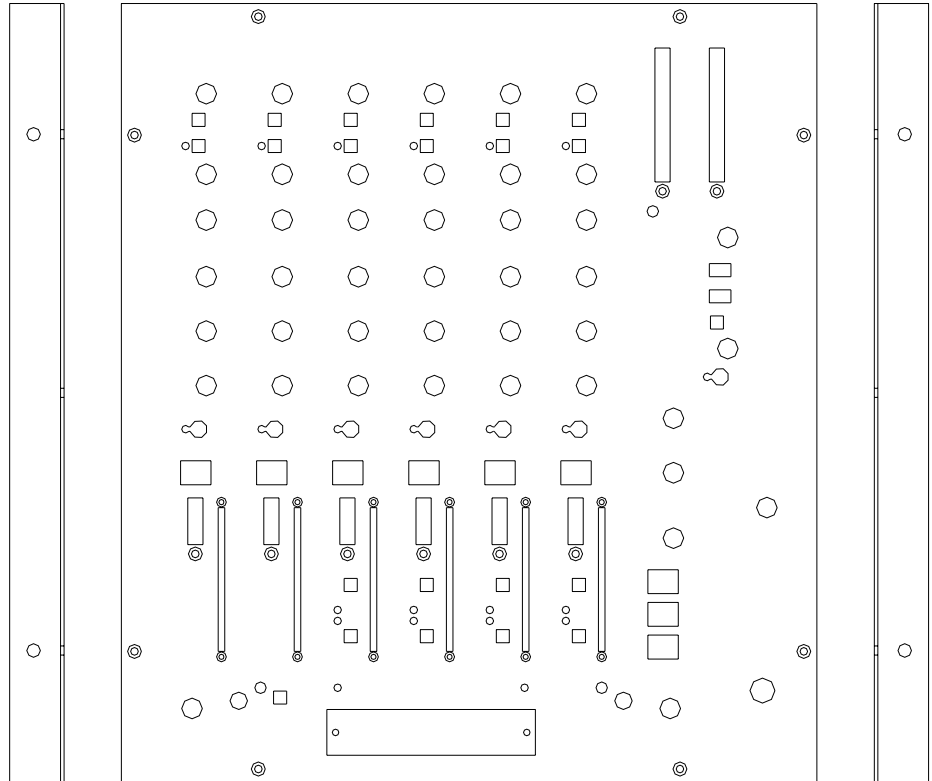

- 

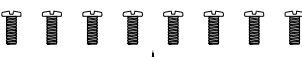
6x M4x8 PAN POZI SCREWS
- 

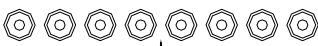
8x M6x16 PAN SLOT SCREWS
- 

8x M6 CUP WASHERS

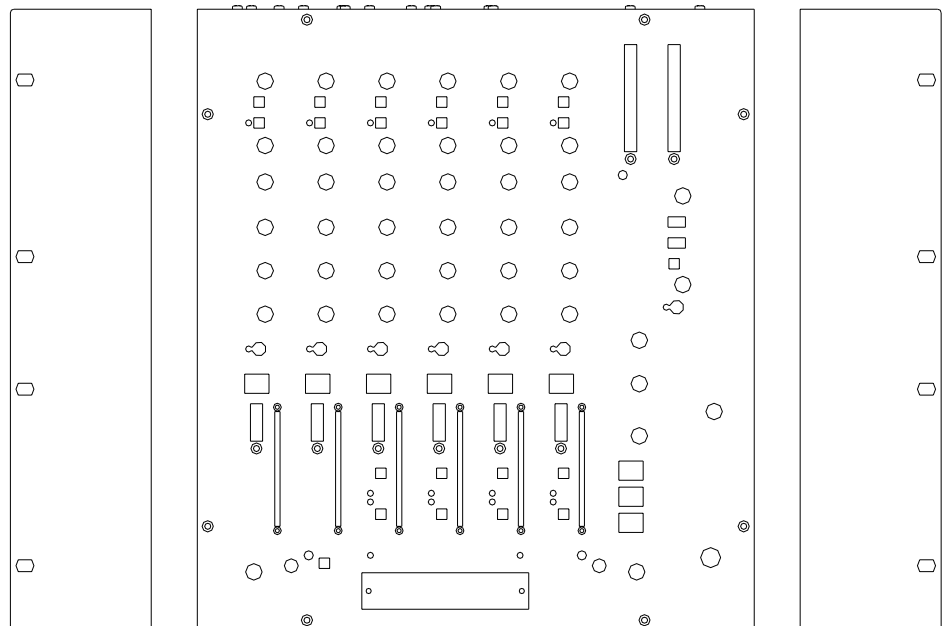

Connecting Mains Power

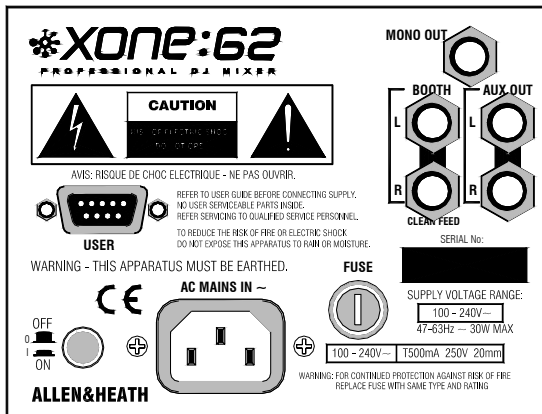

Read the **SAFETY INSTRUCTIONS** printed at the front of this Service Manual. Check that the correct mains lead with moulded plug has been supplied with the console. The power supply accommodates mains voltages within the range 100-240V without changing any fuses or settings.

It is standard practice to turn connected power amplifiers down or off before switching the console on or off. Ensure that the IEC mains plug is pressed fully into the rear panel socket before switching on.

Earthing



The connection to earth (ground) in an audio system is important for two reasons:

1. **SAFETY** - To protect the operator from high voltage shock, and
2. **AUDIO PERFORMANCE** - To minimise the effect of earth (ground) loops which result in audible hum and buzz, and to shield the audio signals from interference.

For safety it is important that all equipment earths are connected to mains earth so that exposed metal parts are prevented from carrying high voltage which can injure or even kill the operator. It is recommended that the sound engineer check the continuity of the safety earth from all points in the system including microphone bodies, turntable chassis, guitar strings, connector cases, equipment panels and so on.

The same earth is also used to shield audio cables from external interference such as the hum fields associated with power transformers, lighting dimmer buzz, and computer radiation. Problems arise when the signal sees more than one path to mains earth. An 'earth loop' (ground loop) results causing current to flow between the different earth paths. This condition is usually detected as a mains frequency audible hum or buzz.

To ensure safe and trouble-free operation we recommend the following:

- **Have the mains system checked by a qualified electrician.** If the supply earthing is solid to start with you are less likely to experience problems.
- **Do not remove the earth connection from the console mains plug.** The console chassis is connected to mains earth through the power cable to ensure your safety. Audio 0V is connected to the console chassis internally. If problems are encountered with earth loops operate the audio 'ground lift' switches on connected equipment accordingly, or disconnect the cable screens at one end, usually at the destination.
- **Make sure that turntables are correctly earthed.** A chassis earth terminal is provided on the console rear panel to connect to turntable earth straps.
- **Use low impedance sources** such as microphones and line level equipment rated at 200 ohms or less to reduce susceptibility to interference. The console outputs are designed to operate at very low impedance to minimise interference problems.
- **Use balanced connections where possible** as these provide further immunity by cancelling out interference that may be picked up on long cable runs. To connect an unbalanced source to a balanced console input, link the cold input (XLR pin 3 or jack ring) to 0V earth (XLR pin 1 or jack sleeve) at the console. To connect a balanced XLR output to unbalanced equipment, link the cold output to 0V earth at the console.
- **Use good quality cables and connectors** and check for correct wiring and reliable solder joints. Allow sufficient cable loop to prevent damage through stretching.

Plugging Up The System

The **XONE:62** uses professional grade 3 pin XLR, 1/4" TRS jack and RCA PHONO sockets. To ensure best performance, we recommend the use of high quality audio cables and connectors, and that time is taken to check for reliable and accurate cable assembly. It is well known that most audio system failures are due to faulty interconnecting leads. The following mating plugs may be used to connect audio signals to the console:

All input and output **XLR** connectors are 3 wire differentially balanced. These have 3 connector pins: Pin 1 = ground (screen), Pin 2 = signal hot (+), Pin 3 = signal cold (-).

All the jack sockets are the 3 pole **TRS** type. These are wired to work with both the balanced TRS or the unbalanced 2 pole TS type plugs. The sockets have 3 connector pins: Inputs and outputs are Tip = signal hot (+), Ring = signal cold (-), Sleeve = ground (screen). Insert connections are Tip = send, Ring = return, Sleeve = ground.

The **RCA** phono connectors are the 2 wire unbalanced type typical of those found on equipment such as CD players, turntables and domestic amplifiers.

Avoid reversing + and - on balanced connections as this will result in out of phase signals (reverse polarity) which may cause signal cancellation effects.

For live work where long cables runs are required, balanced interconnections should be used. However, interconnections between more affordable 2-wire (signal, ground) unbalanced equipment and the console are unlikely to cause problems if the cables are kept short. Refer to the following diagram for unbalanced to balanced connections.

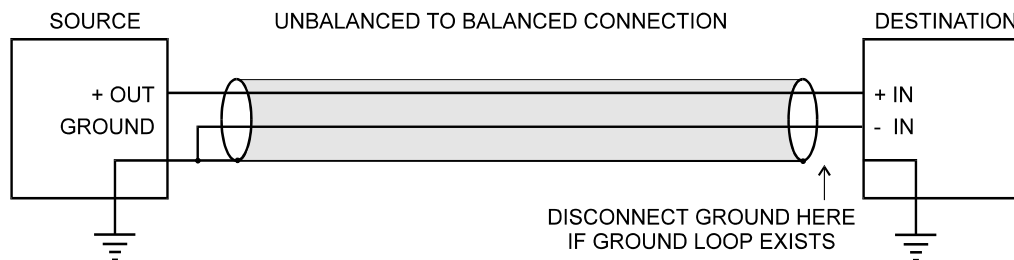

Dealing with Ground Loops, Buzz and Interference

For optimum performance all audio signals should be referenced to a solid, noise-free ground (earth) point, frequently referred to as the 'star point' or 'clean earth'.

A ground loop is created when the signal has more than one path to ground. Should you experience hum or buzz caused by ground loops, check first that each piece of equipment has its own separate path to ground. If so, operate ground lift switches on connected equipment in accordance with the instruction manuals. Alternatively disconnect the cable screen at the destination end only. This breaks the offending loop while still maintaining the screening down the length of the cable.

▲ WARNING For your safety do not remove the earth (ground) connection in the power lead of the console or connected equipment.

To avoid interference pickup keep audio cables away from mains power units and cables, thyristor dimmer units or computer equipment. Where this cannot be avoided, cross the cables at right angles to minimise interference.

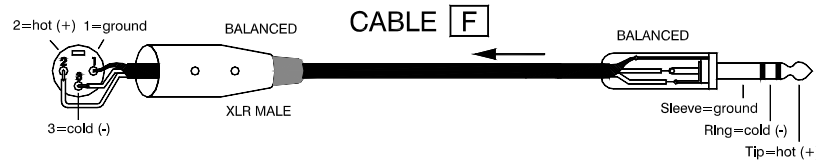
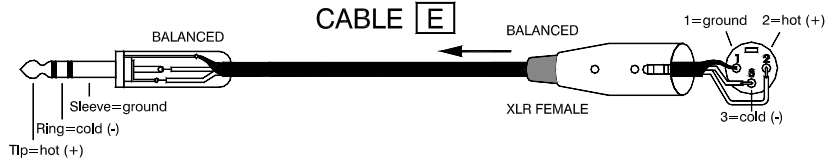
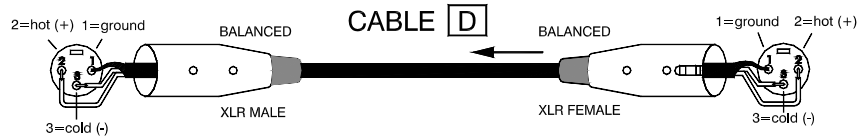
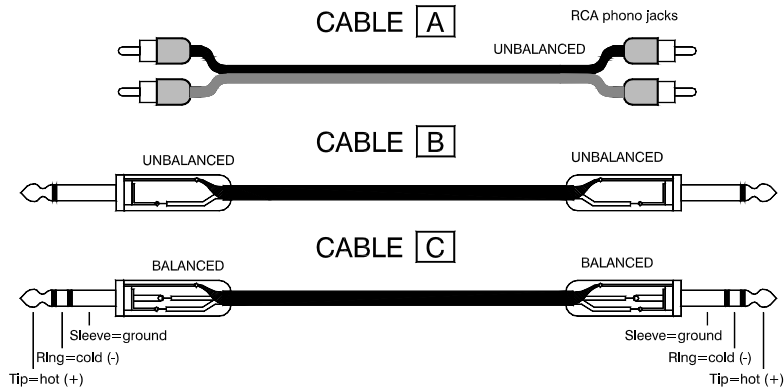
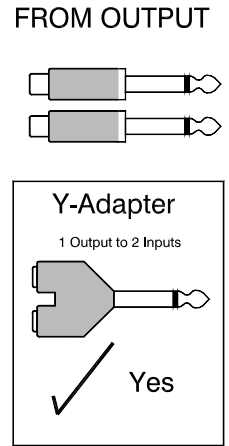
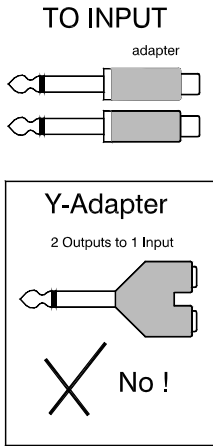
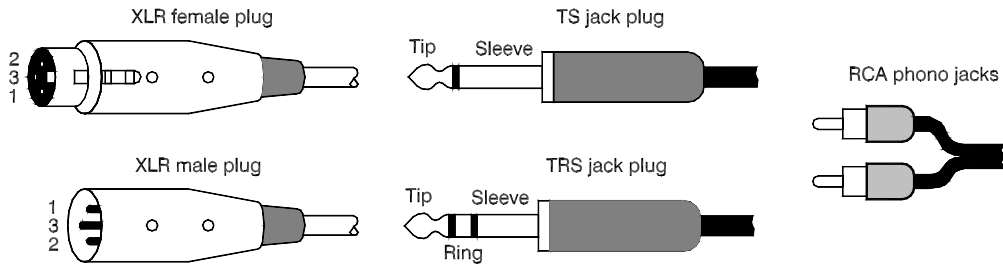

TO INPUT

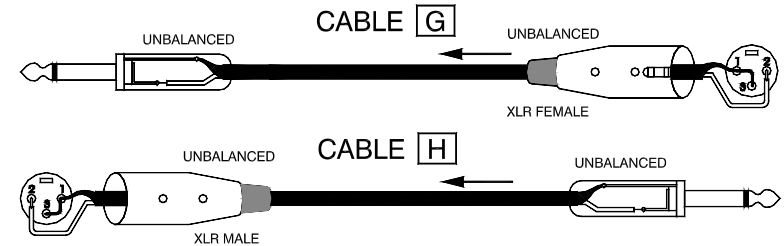

FROM OUTPUT

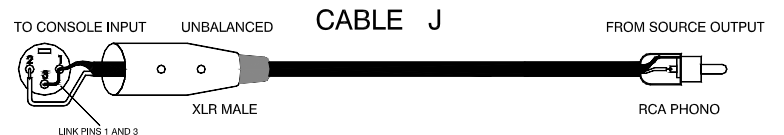
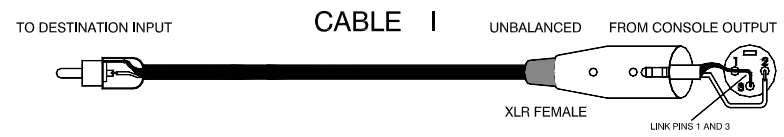

Replacing the Crossfader

The crossfader on a DJ mixer is heavily used and can suffer considerable wear and tear. The audio design using VCAs prevents clicks and scratchiness as the fader wears. However, the movement can become mechanically stiff or sloppy in time, or become ingrained with dirt and the fader may need replacement.

The **XONE:62** crossfader is removable and can easily be replaced in a few minutes. The spare fader is supplied as a plug-in assembly which can be ordered through your Allen & Heath dealer.

Note: There are two versions of crossfader assembly. These are not interchangeable. Make sure you order the correct version.

The VERSION 1 model uses the Alps crossfader assembly:

XONE:62 Crossfader Assembly Part number 002-718

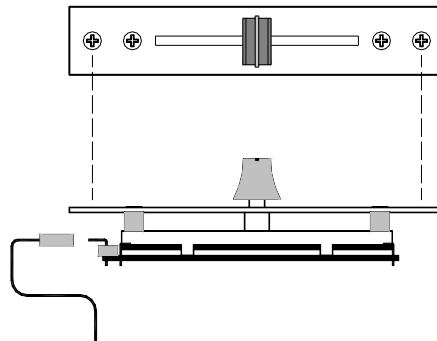

The VERSION 2 model uses the Penny & Giles crossfader assembly :

XONE:62 Crossfader Assembly Part number 002-719

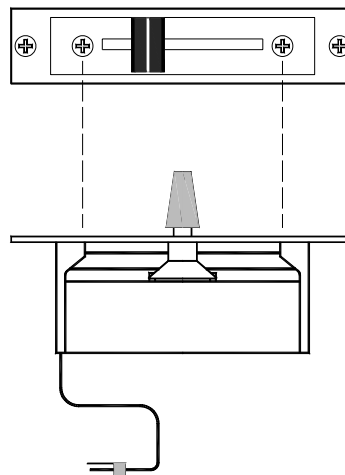

To replace either version of crossfader use a medium size cross-point (Pozidriv) screwdriver to undo and remove the two outer screws on the crossfader plate. Do not remove the inner screws.

Lift the crossfader assembly up and away from the console panel.

Unplug the cable from the old crossfader or circuit assembly (depending on version) and plug on the new assembly. Check that the connector is correctly aligned and seated.

Replace the assembly making sure the cable faces the left side of the console. Refit the screws and test for correct operation.

Tips and Troubleshooting

From the User Guide:



For your safety do not remove the **EARTH** (ground) connection in the power lead of the console or connected equipment.



Have your **MAINS SYSTEM** checked by a qualified electrician. If the earthing is solid to start with you are less likely to experience problems.



Use high grade **AUDIO CABLES** and check them for reliable connection. It is well known that many audio system problems are due to faulty cables and connectors.



In a club or similar installation strict **SOUND LEVEL** and noise regulations may apply. Check that your system levels are correctly set up to comply.



To avoid damage to your hearing start with the **HEADPHONES** level control at minimum and turn up only as much as is needed to maintain comfortable listening level. Do not drive headphones at high listening levels for long periods of time.



Always switch connected **AMPLIFIERS** on last and off first to avoid thumps when the console and connected equipment is turned on or off.



Reduce gain if the red meter **PEAK** led flashes. These warn you that you are near clipping which may result in system overload and distortion. The **XONE:62** provides plenty of drive and headroom when operated around the 0 to +6 meter points. Check that the amplifier / speaker system is correctly matched and set up for correct levels.



Increasing **VCF RESONANCE** boosts a narrow band of selected frequencies. Make sure you reduce the channel gain if the red peak meters start to flash. It is best to start experimenting with this control set to minimum.



If you suspect a console fault. The console is the heart of the audio system and is often suspected faulty when a problem occurs. Usually the fault is found to be with other equipment in the system, typically the interconnecting leads, input sources, or level matching between equipment. Check for source problems by unplugging each channel in turn listening for a change in symptom. To check the console, isolate it by unplugging all sources and outputs leaving just headphones and a reference source such as a CD player connected.



I have plugged in a microphone but it does not work. The **XONE:62** is designed to operate with non-phantom powered dynamic microphones such as the popular vocal types. Do not use microphones which require phantom power.



The stereo channel sounds very distorted with high level and excessive bass. Only plug turntables needing RIAA equalisation into CH 3-6 PHONO inputs. Other equipment should be plugged into the LINE inputs.



There is a hum on the turntable channels. Check that the turntable earth strap has been correctly connected to the console chassis earth post. Also check that the turntable headshell and cartridge are correctly aligned and plugged in.



Only one side of the stereo mix is working. Check that the XFADE PAN control is not set fully to either L or R. Also check for bad connections, in particular turntable headshell and cartridge pins.



There is feedback. Check that the microphone is not placed next to the headphones. The mic may pick up its own signal from the headphones and feed back. In loud listening conditions feedback can sometimes be caused by mechanical vibration through the turntables into the cartridge, or even the needle resting on a cued turntable starting to resonate in the groove of the record.



When the VCF is switched on there is very little sound. Operate the VCF frequency control to restore the frequency content of the sound.



There is no monitor output. Check that a channel CUE switch is not already selected. This is indicated by the red CUE led under the monitor meters. Also check that AUX is not selected.



There is no stereo channel signal. Check that the input selector switch is correctly set.



The crossfader is not working. Make sure the channel XFADE ON switch is pressed and X or Y correctly selected.



The crossfader works backwards. Check that it has been re-fitted the right way round if previously removed.



I have connected a stereo source to a single input using a Y-adaptor but it sounds bad. Do not connect more than one output to the input. These adaptors are designed to feed one output to two inputs, not the other way round.



Gain and Operating Levels



It is most important that the system gain and level settings are correctly set. It is well known that many DJs push the gain to maximum with meters peaking hard in the belief that they are getting the best from the system. **THIS IS NOT THE CASE!** The best can only be achieved if the system levels are set within the normal operating range and not allowed to peak. Peaking simply results in signal distortion, not more volume. It is the specification of the amplifier / speaker system that sets the maximum volume that can be achieved, not the console. The human ear too can fool the operator into believing that more volume is needed. Be careful as this is in fact a warning that hearing damage will result if high listening levels are maintained. Remember that it is the **QUALITY** of the sound that pleases the ear, not the **VOLUME**.

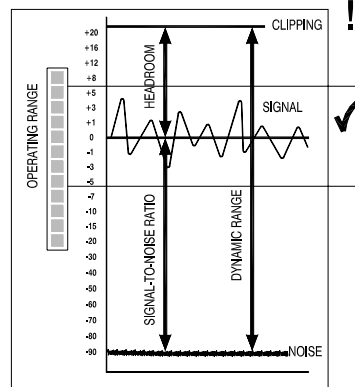
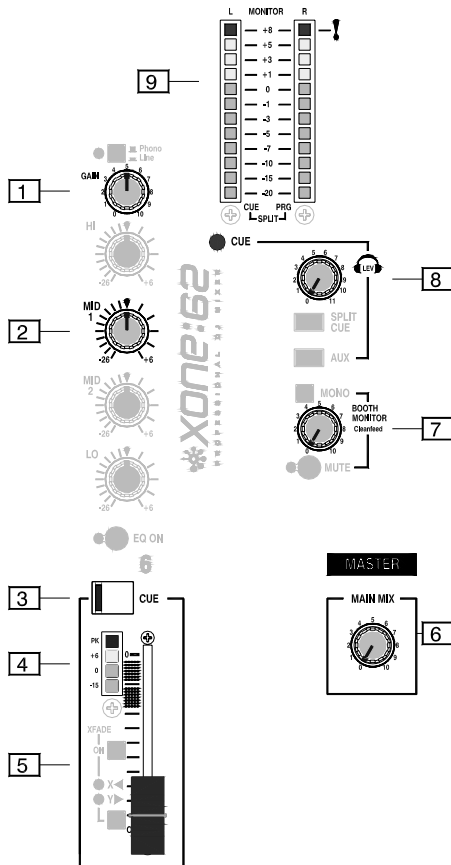

The diagram above illustrates the operating range of the audio signal.

NORMAL OPERATING RANGE. For normal music the signal should range between -5 and $+5$ on the meters with average around 0 dB. This allows enough **HEADROOM** for unexpected peaks before the signal hits its maximum **CLIPPING** voltage and distorts. It also achieves the best **SIGNAL-TO-NOISE-RATIO** by keeping the signal well above the residual **NOISE FLOOR** (system hiss). The **DYNAMIC RANGE** is the maximum signal swing available between the residual noise floor and clipping. The **XONE:62** provides a massive 110 dB dynamic range.

Use the **GAIN TRIM** [1] to match the input source to the normal operating level of the console. Adjust this so that the **CHANNEL METER** [4] averages 0 dB with loudest moments reading $+6$. Press the **CUE SWITCH** [3] to listen to the signal on headphones and check the level on the expanded range **MAIN METERS** [9]. Adjust the **CHANNEL FADER** [5] and **MASTER FADER** [6] so that they normally operate in the shaded area near the top. Make sure the amplifier/speaker system has been correctly calibrated for the loudest volume required at the fader top position. Boosting the **EQ** [2] also adds gain to the system. Reduce by turning back the **GAIN TRIM** [1] if the meter red peak leds flash. Adjust the **HEADPHONES** [8] and **BOOTH** [7] monitor controls for safe listening levels.

A final note ... The human ear is a remarkable organ with the ability to compress or 'shut down' when sound levels become too high. Do not interpret this natural response as a reason to turn the system volume up further! As the session wears on ear fatigue may set in, and the speaker cones may become hot so reducing the effectiveness of the system and listeners to gain any benefit from increased volume.

BE SENSIBLE, BE SAFE WITH SOUND LEVELS



h
g
f
e
d
c
b
a

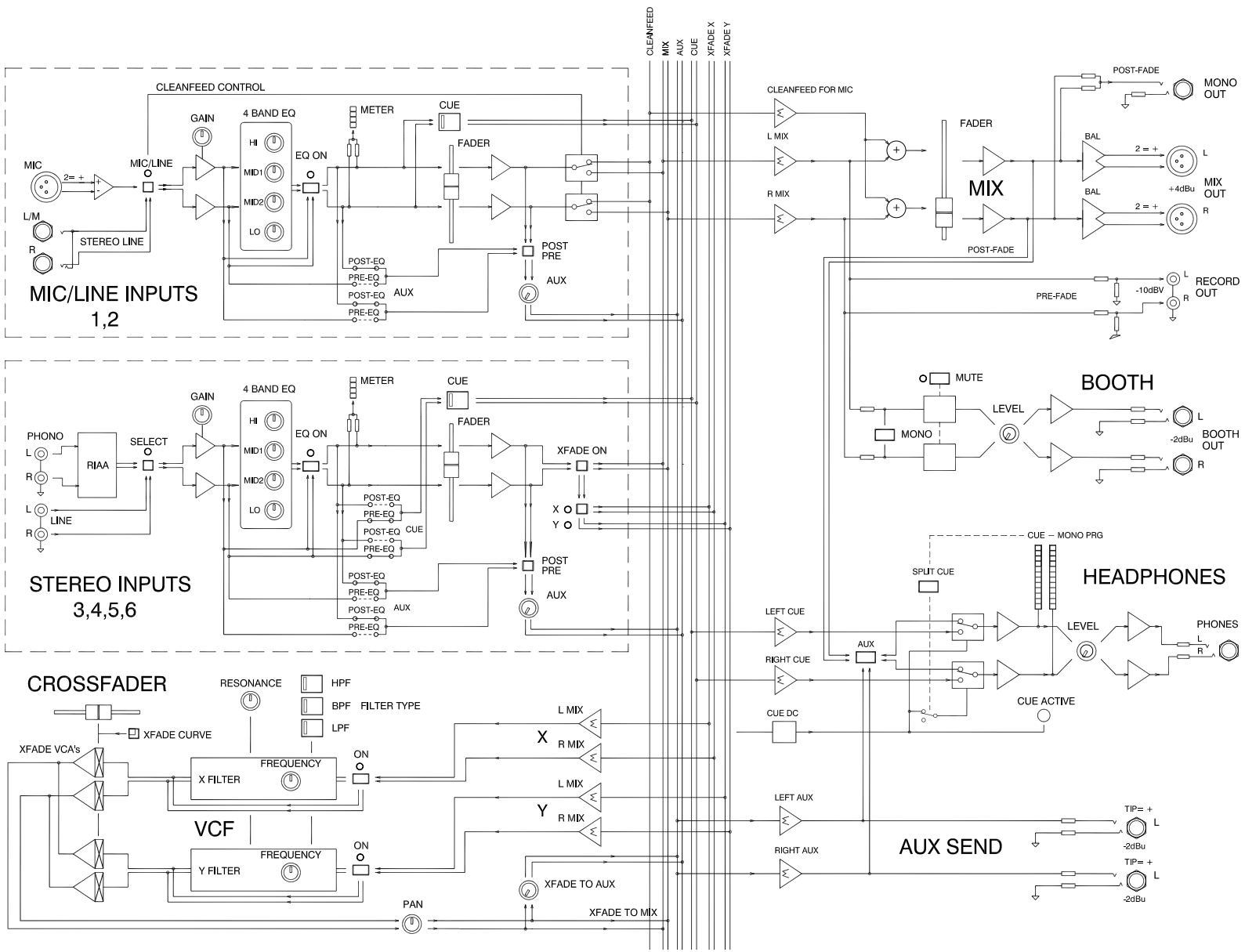

ALLEN & HEATH
 Kernick Industrial Estate,
 Penryn, Cornwall,
 England, TR10 9LJ
 Tel: (44) (0)1870 7556250 Fax: (44) (0)1870 7556251

XONE:62
BLOCK DIAGRAM
 VERSION 1 model

A B C D E F G H

h
g
f
e
d
c
b
a

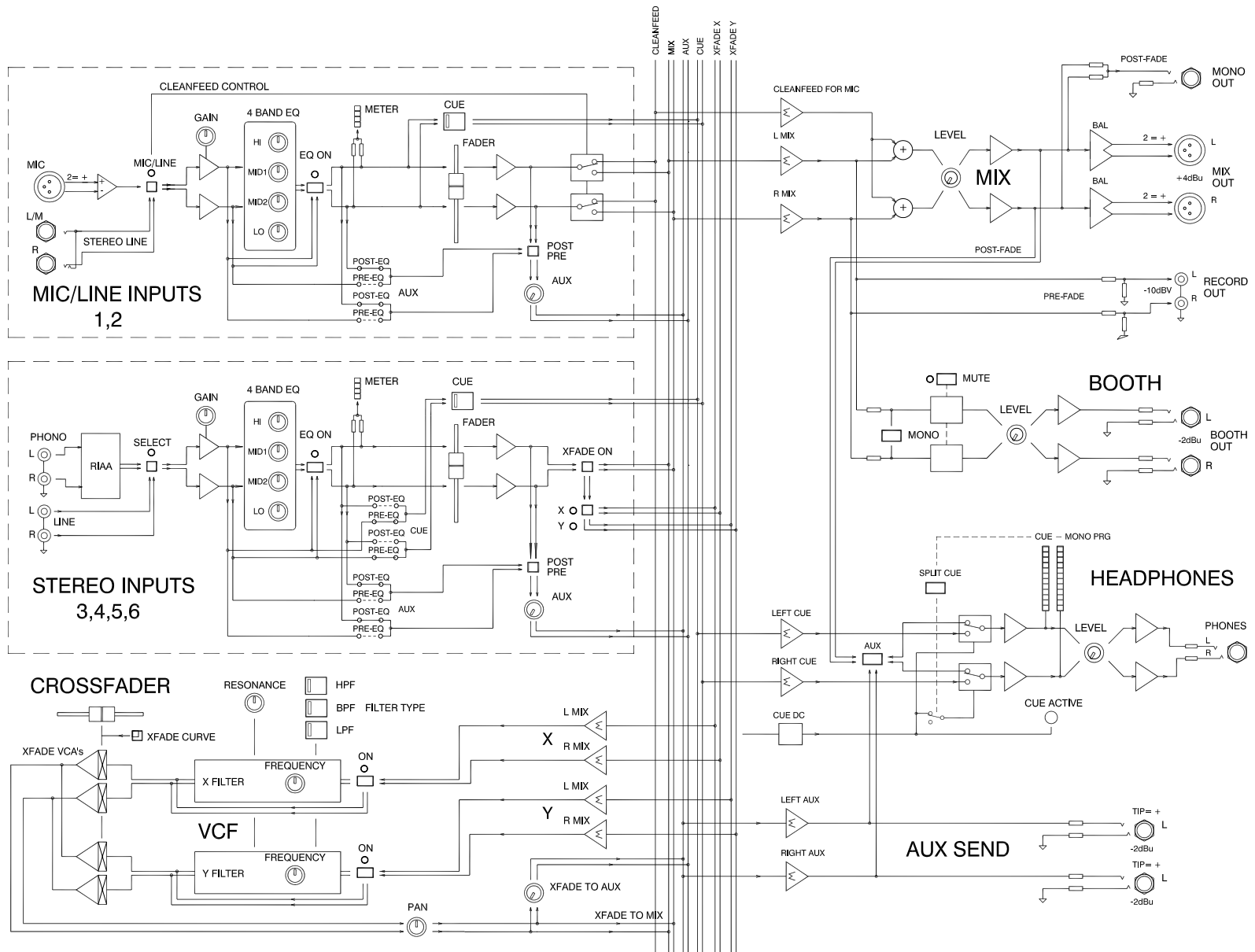

ALLEN & HEATH

Kernick Industrial Estate,
Penryn, Cornwall,
England, TR10 9LJ
Tel: (44) (0)1870 7556250 Fax: (44) (0)1870 7556251

XONE:62
BLOCK DIAGRAM
VERSION 2 model

A B C D E F G H

h
g
f
e
d
c
b
a

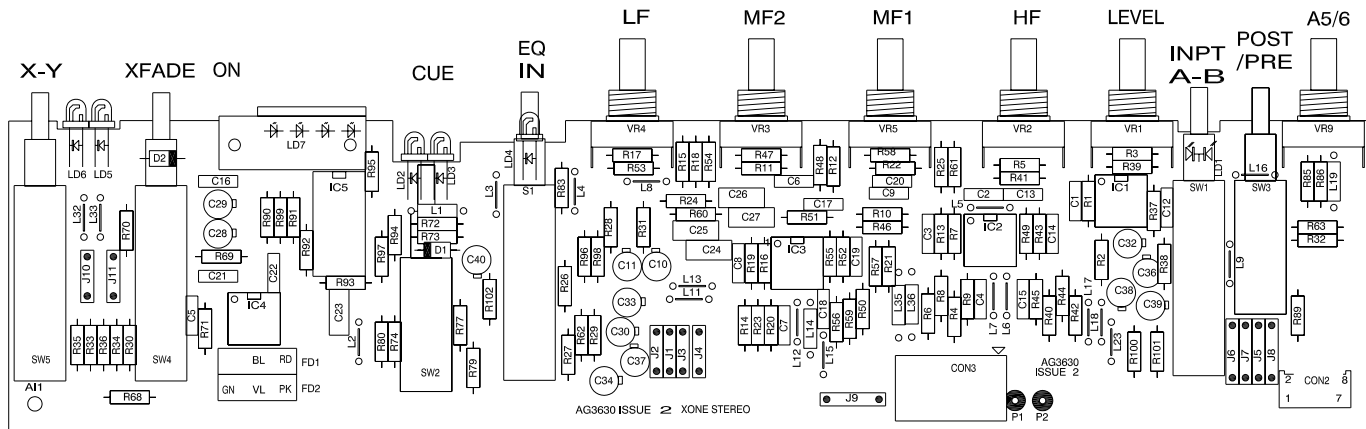

ALLEN & HEATH

Kernick Industrial Estate,
Penryn, Cornwall,
England, TR10 9LU
Tel: (44) (0)1870 7556250 Fax: (44) (0)1870 7556251

XONE:62
INPUT PCB
AG3630 issue 2

A

B

C

D

E

F

G

H

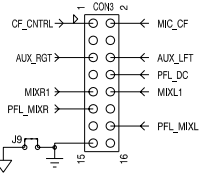
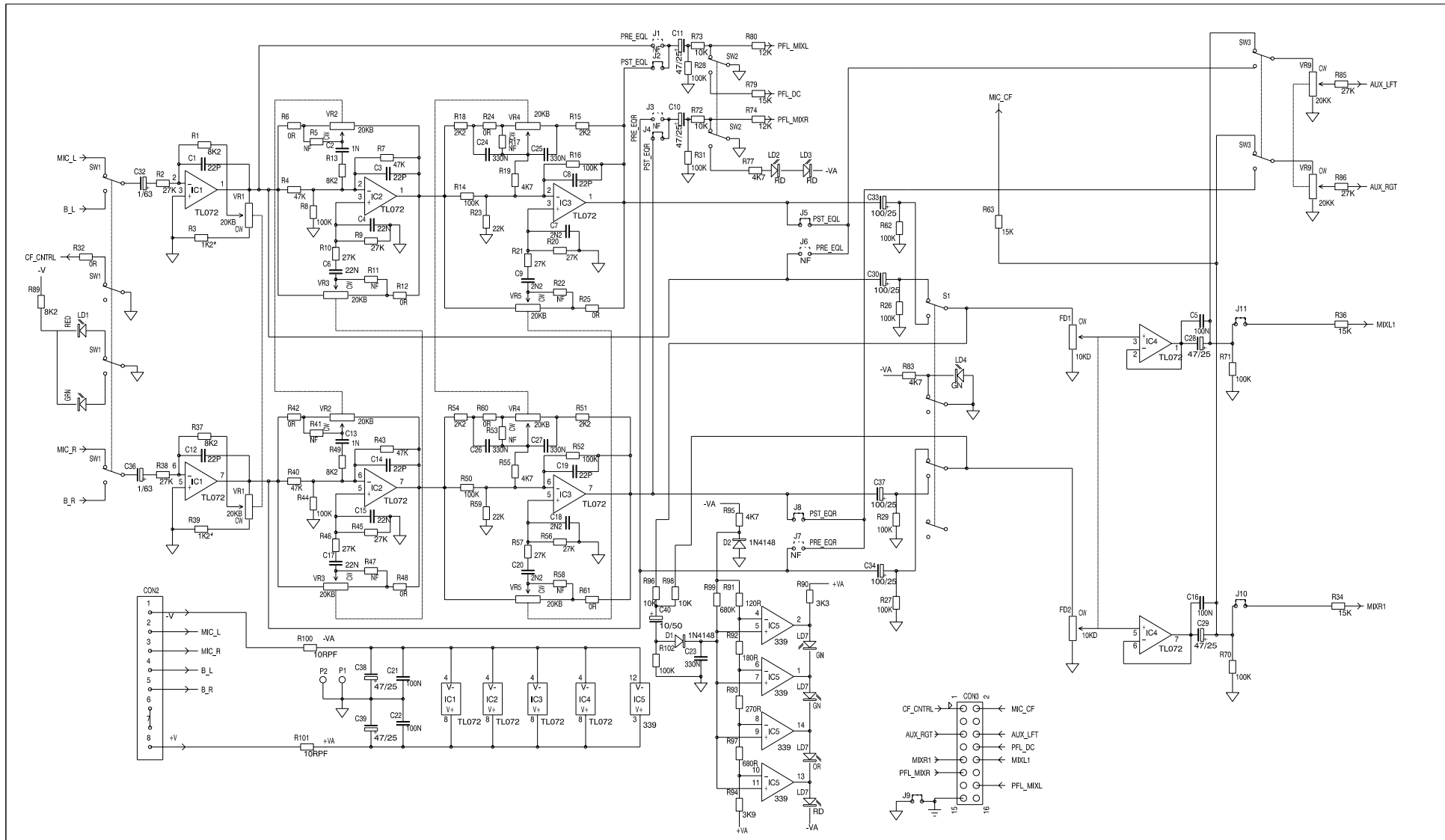

ISS.	REVISION	BY DATE
B	REVISED LAYOUT/EQ UPDATES	ARJ 25-6-99
C	4POLE EQ SW	ARJ 2-08-99
A	PRODUCTION	ARJ 18-8-99
1	XONE62 MIC CH	ARJ 11-10-99

ALLEN & HEATH
 Kernick Industrial Estate,
 Penryn, Cornwall,
 England, TR10 8LU
 Tel: (44) (0)1870 7556250 Fax: (44) (0)1870 7556251

XONE:62
 INPUT 1-2 CIRCUIT
 C3630 issue 1

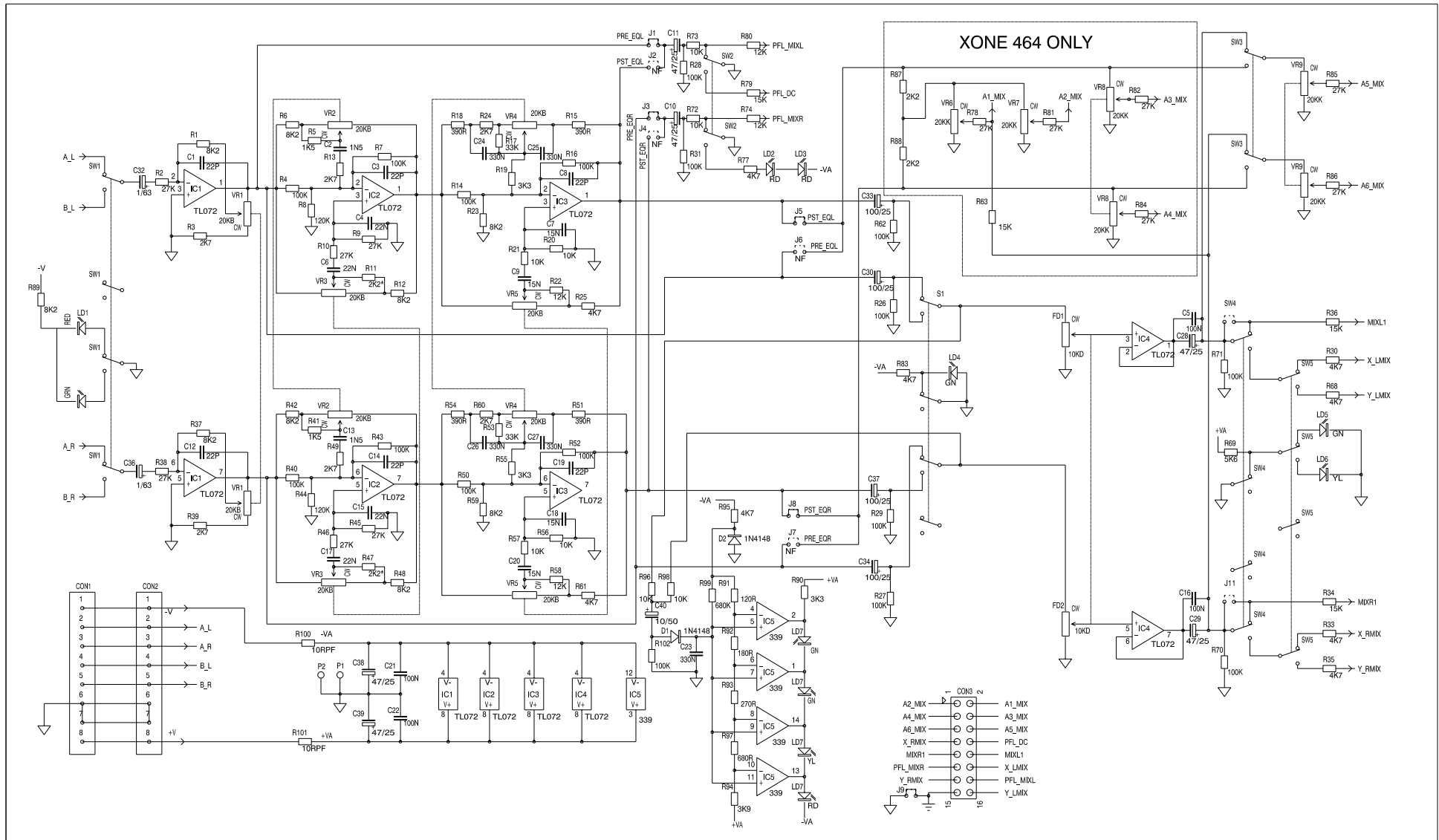

ISS.	REVISION	BY DATE
B	REVISED LAYOUT/EQ UPDATES	ARJ 25-6-99
C	4POLE EQ SW	ARJ 2-08-99
1	PRODUCTION	ARJ 18-8-99
2	CLEANFEED	ARJ 14-9-99

ALLEN & HEATH
 Kernick Industrial Estate,
 Penryn, Cornwall,
 England, TR10 9LU
 Tel: (44) (0)870 7556250 Fax: (44) (0)870 7556251

XONE:62
 INPUT 3-6 CIRCUIT
 C3630 issue 2

h
g
f
e
d
c
b
a

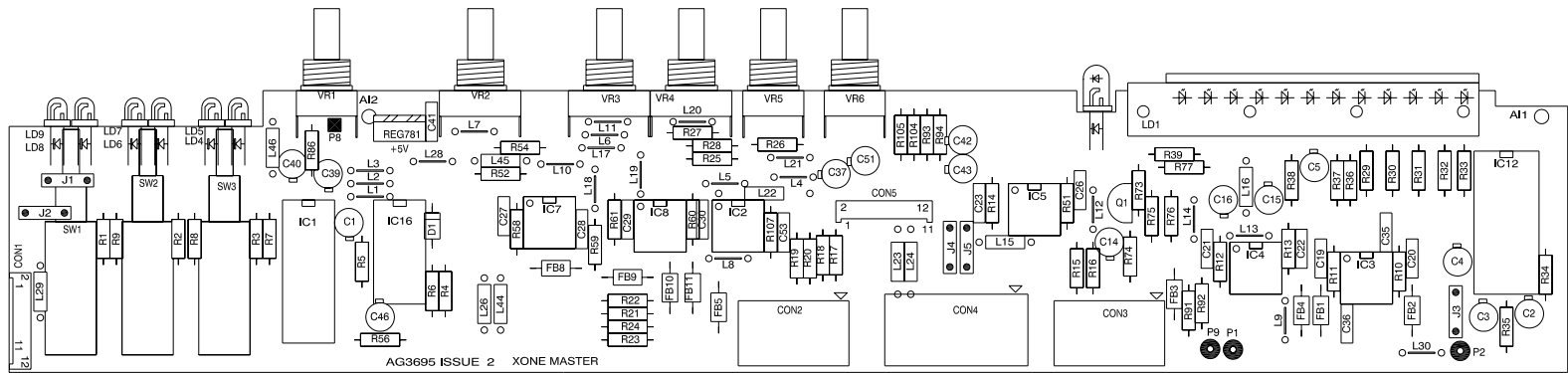

ALLEN & HEATH

Kernick Industrial Estate,
Penryn, Cornwall,
England, TR10 9LU
Tel: (44) (0)1870 7556250 Fax: (44) (0)1870 7556251

XONE:62
LEFT PCB
AG3695 issue 2

A

B

C

D

E

F

G

H

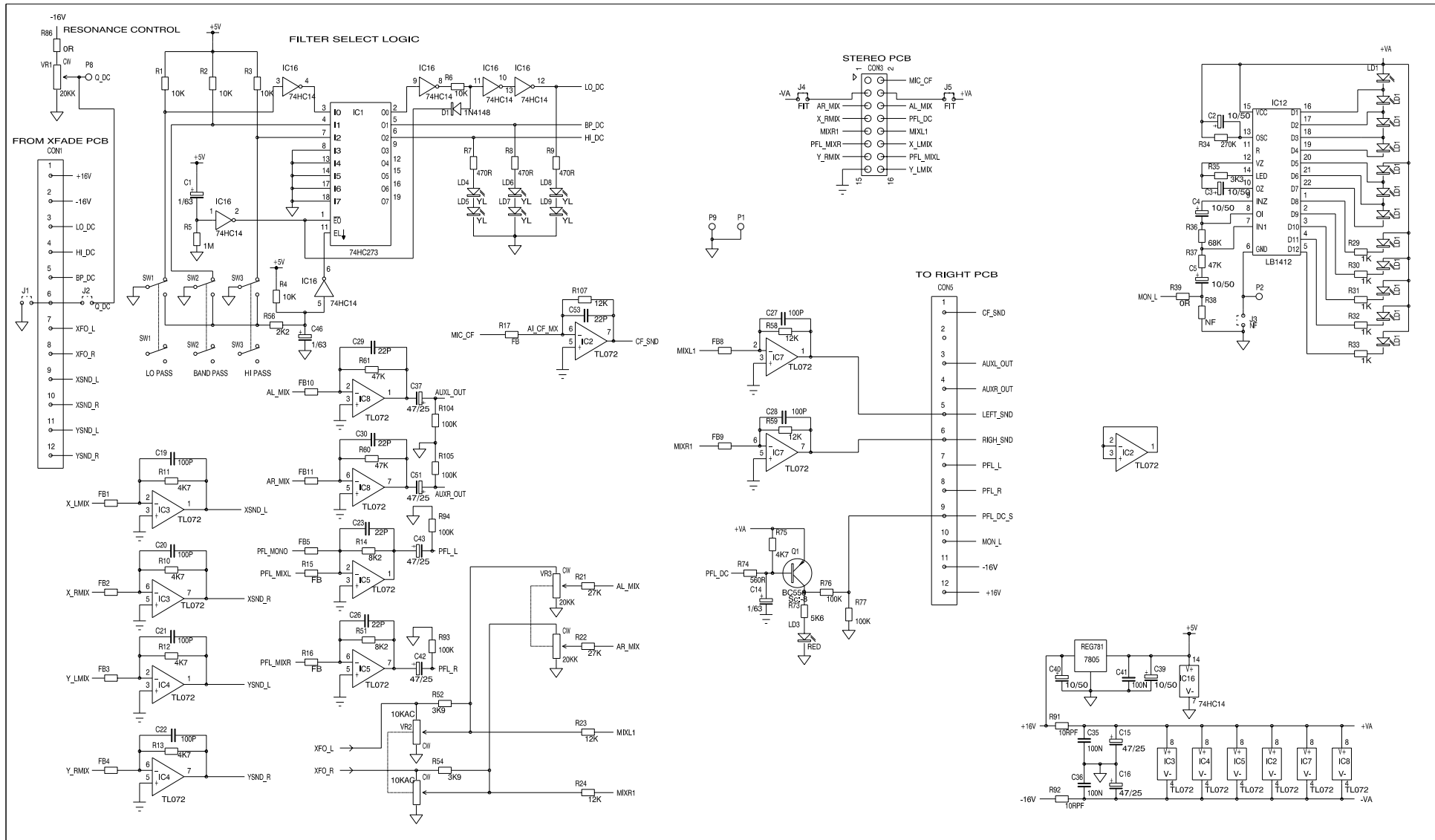

ISS.	REVISION	BY DATE
1	PRODUCTION	ARJ 6-8-99
2	AUX UPDATE	ARJ 9-9-99

ALLEN & HEATH
 Kernick Industrial Estate,
 Penryn, Cornwall,
 England, TR10 9LU
 Tel: (44) (0)870 7556250 Fax: (44) (0)870 7556251

XONE:62
 LEFT CIRCUIT
 C3695 issue 2

h
g
f
e
d
c
b
a

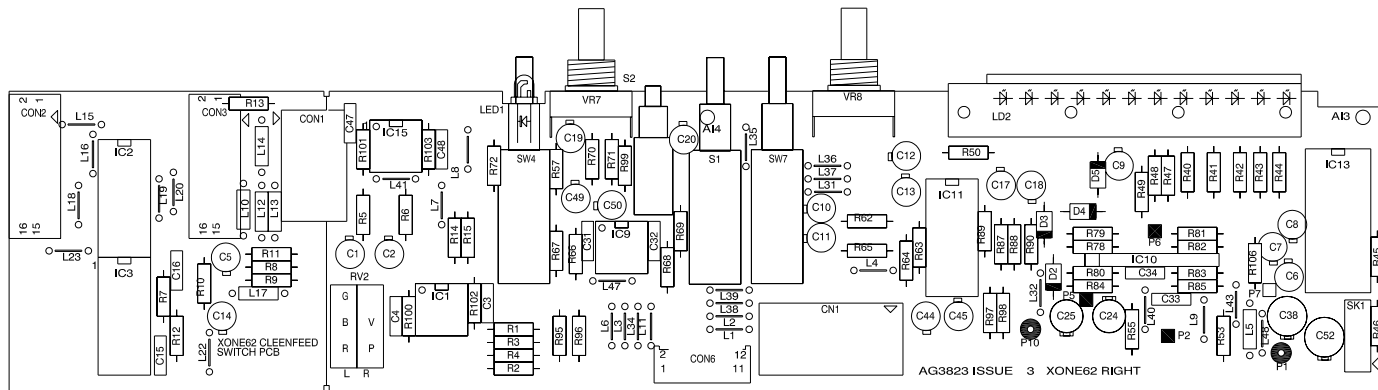

ALLEN&HEATH

Kernick Industrial Estate,
Penryn, Cornwall,
England, TR10 9LU
Tel: (44) (0)1870 7556250 Fax: (44) (0)1870 7556251

XONE:62
RIGHT PCB
AG3823 issue 3

A

B

C

D

E

F

G

XONE:62 SERVICE MANUAL

H

D8

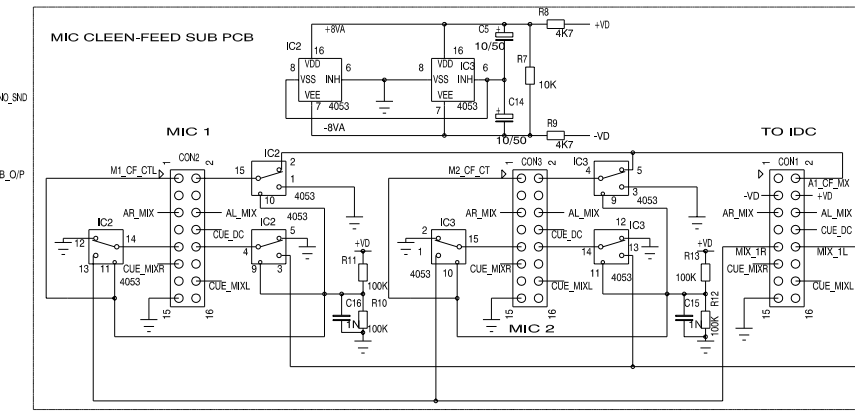
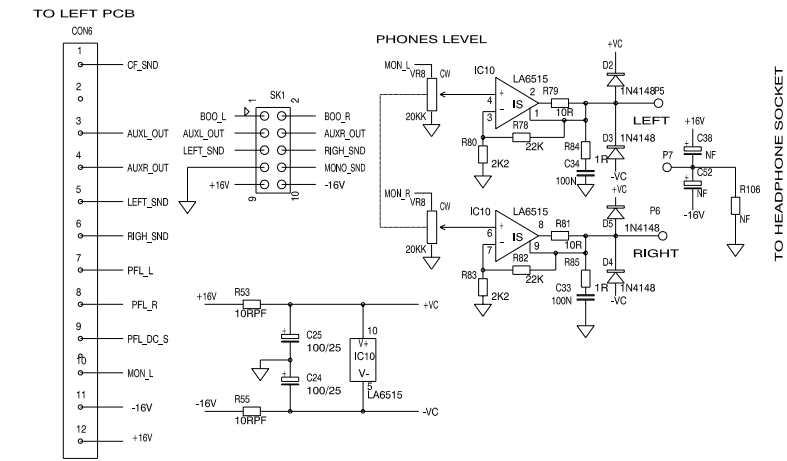
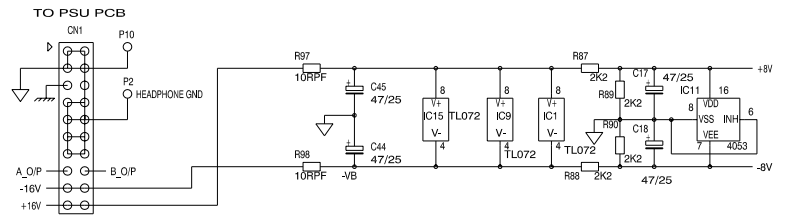
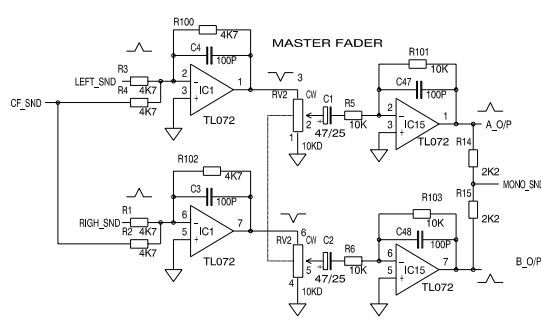
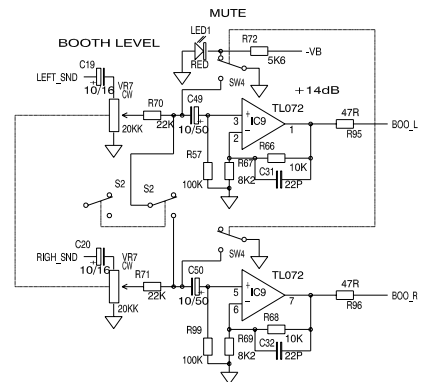
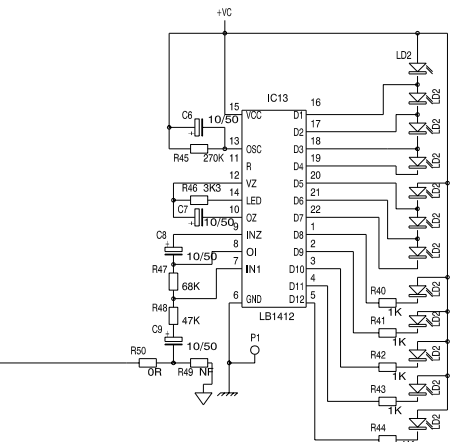
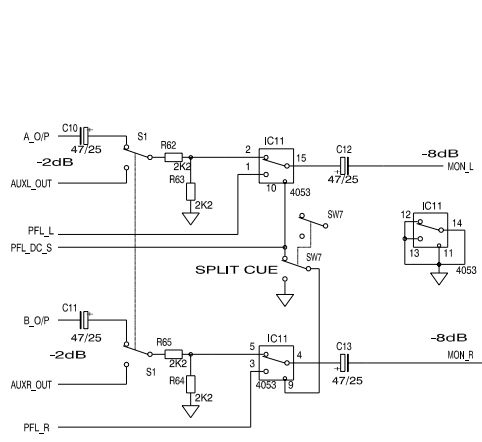

ISS.	REVISION	BY DATE
2	PRODUCTION	ARJ 14-9-99
3	EARTHING	ARJ 4-5-01

ALLEN & HEATH
 Kernick Industrial Estate,
 Penryn, Cornwall,
 England, TR10 9LU
 Tel: (44) (0)870 7556250 Fax: (44) (0)870 7556251

XONE:62
 RIGHT CIRCUIT
 C3823 issue 3

Used on VERSION 2 only

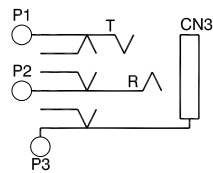
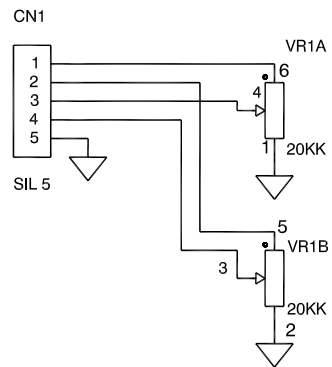

HEADPHONES

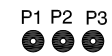
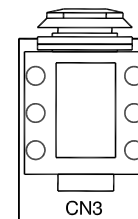

MIX1

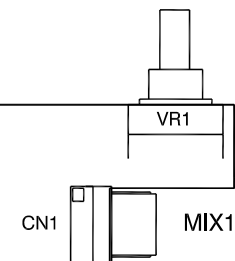

ISSUE	BY	DATE
1	ARJ	3-5-01

ALLEN&HEATH

Kernick Industrial Estate,
Penryn, Cornwall,
England, TR10 9LU
Tel: (44) (0)870 7556250 Fax: (44) (0)870 7556251

XONE:62
ROTARY OUTPUT
AG4233 issue 1

h
g
f
e
d
c
b
a

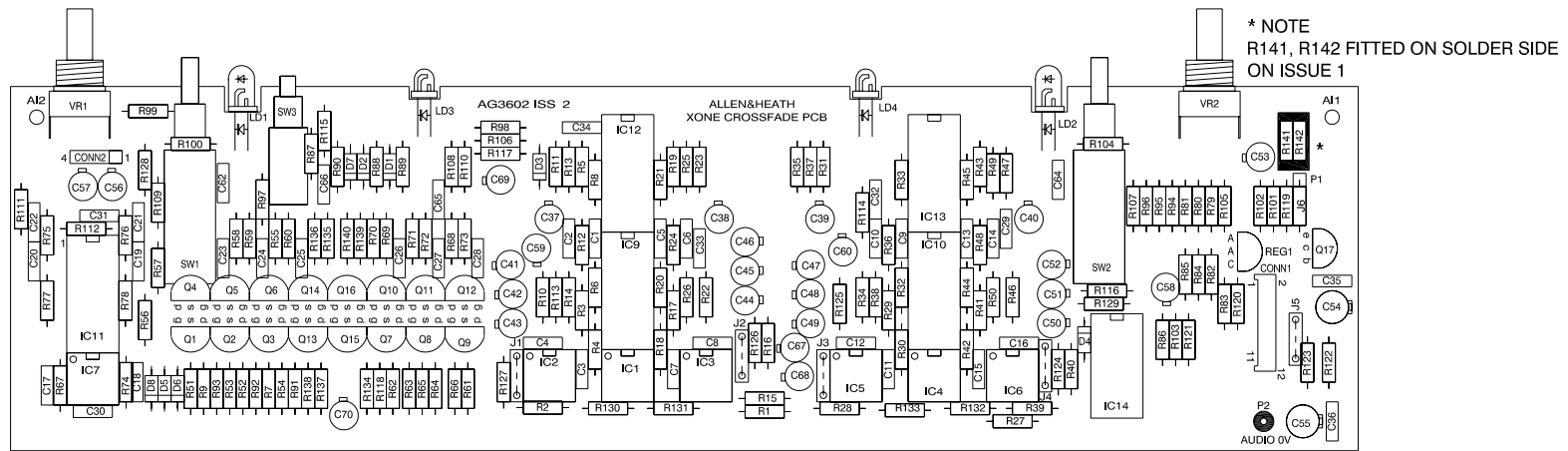

ALLEN&HEATH
 Kernick Industrial Estate,
 Penryn, Cornwall,
 England, TR10 9LU
 Tel: (44) (0)1870 7556250 Fax: (44) (0)1870 7556251

XONE:62
CROSSFADE PCB
 AG3602 issue 2

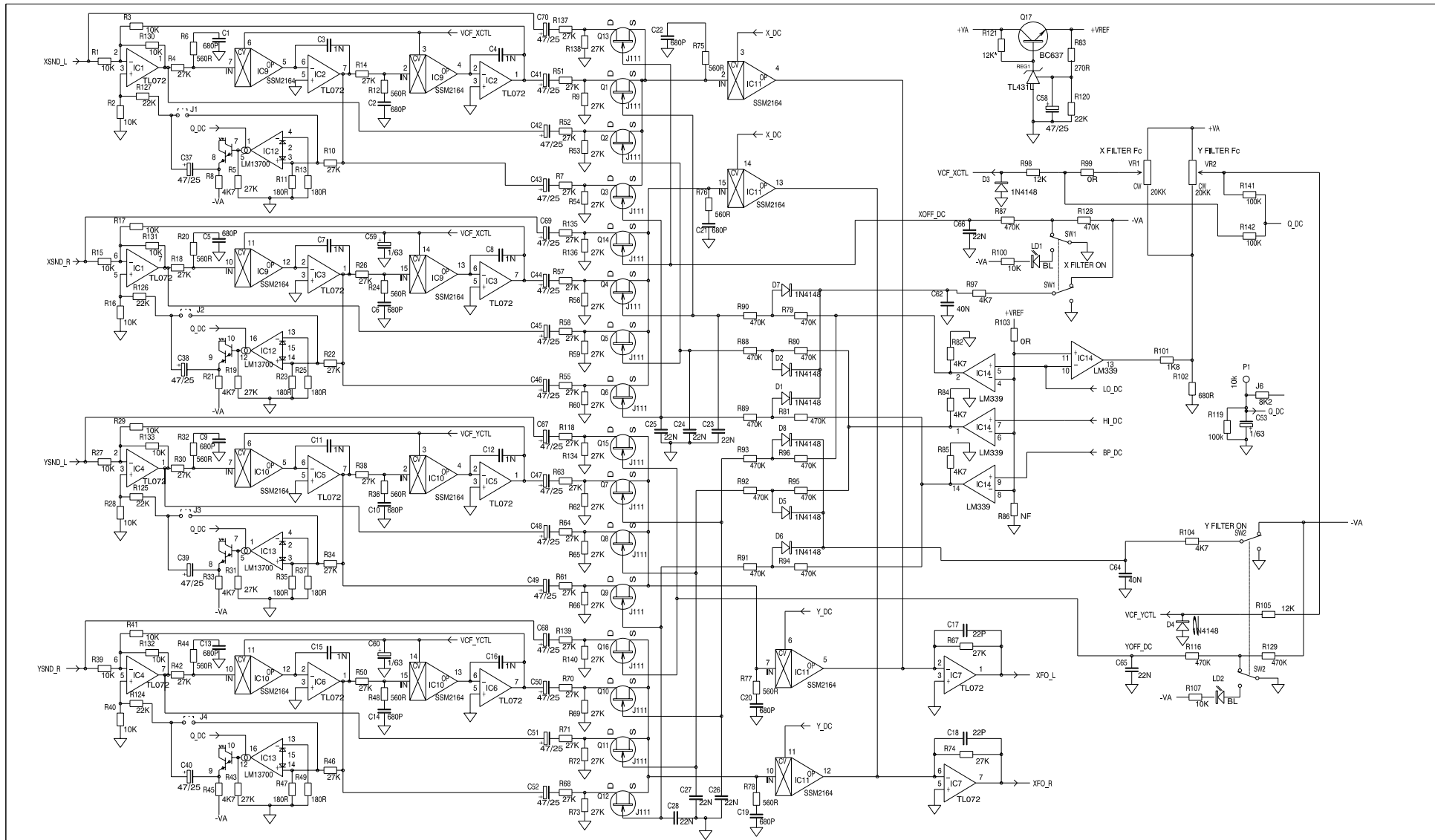

ISS.	REVISION	BY DATE
1	PRODUCTION	ARJ 17-8-99
2	Q_DC LINK	ARJ 18-10-99
2.1	VALUE CHANGES	DWD 27-09-00

ALLEN&HEATH
 Kernick Industrial Estate,
 Perryn, Cornwall,
 England, TR10 9LU
 Tel: (44) (0)870 7556250 Fax: (44) (0)870 7556251

XONE:62
CROSSFADE CIRCUIT
 C3602 issue 2.1 SHEET 1 of 2

12WAY FLEXI
TO MASTER PCB
CONN

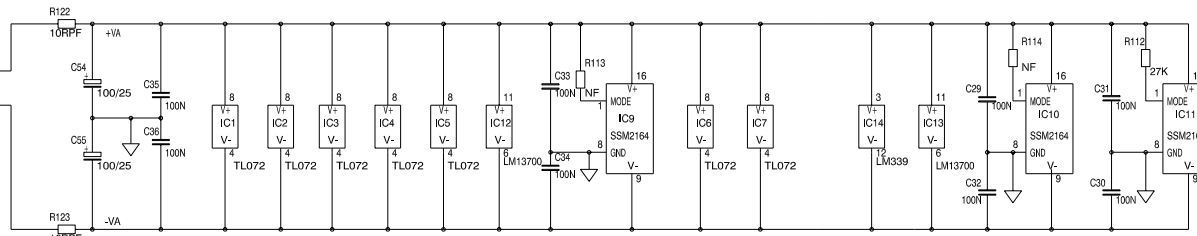
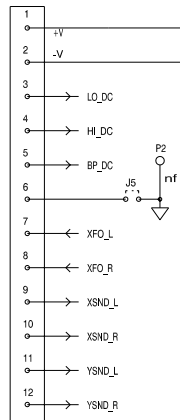

CROSS FADE RESPONSE

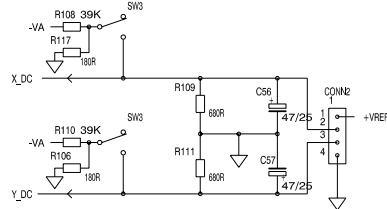

CROSS FADER ASSY
ALPS FADER EARLY XONE

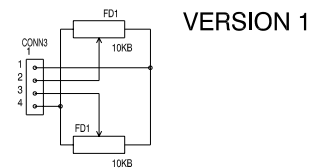

VERSION 1

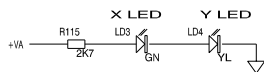

CROSS FADE RESPONSE

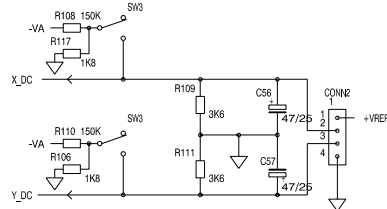

CROSS FADER ASSY
PENNY&GILES FADER LATER XONE

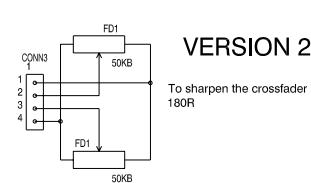

VERSION 2

To sharpen the crossfader response with the P&G fader, change R106, R117 from 1K8 to 180R

ISS.	REVISION	BY DATE
1	PRODUCTION	ARJ 17-8-99
2	Q_DC LINK	ARJ 18-10-99
2.1	VALUE CHANGES	DWD 27-09-00

ALLEN & HEATH
Kernick Industrial Estate,
Perryn, Cornwall,
England, TR10 9LU
Tel: (44) (0)870 7556250 Fax: (44) (0)870 7556251

XONE:62
CROSSFADE CIRCUIT
C3602 issue 2.1 SHEET 2 of 2

h
g
f
e
d
c
b
a

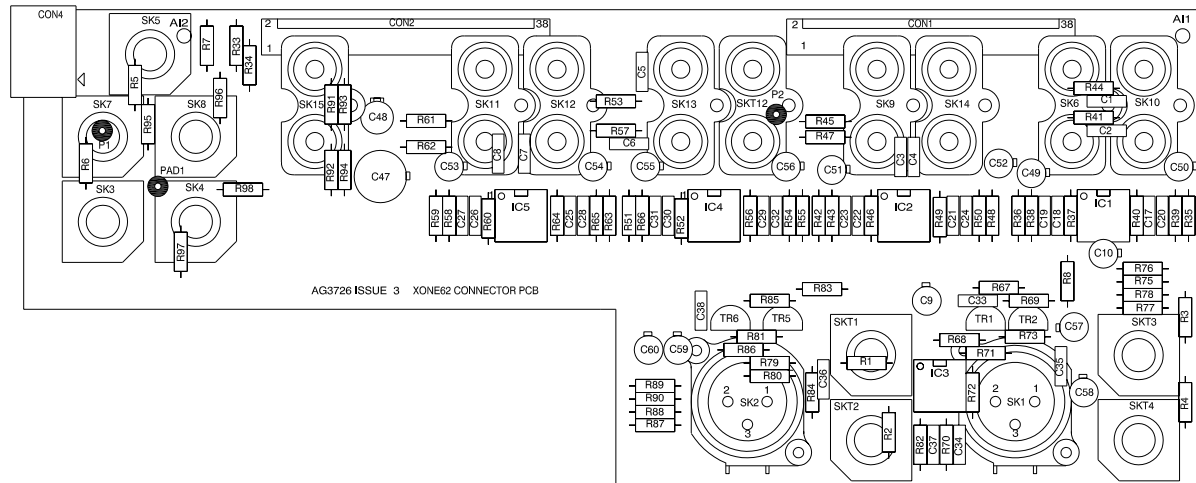

ALLEN&HEATH

Kernick Industrial Estate,
Penryn, Cornwall,
England, TR10 9LJ
Tel: (44) (0)1870 7556250 Fax: (44) (0)1870 7556251

XONE:62
CONNECTOR PCB
AG3726 issue 3

A B C D E F G H

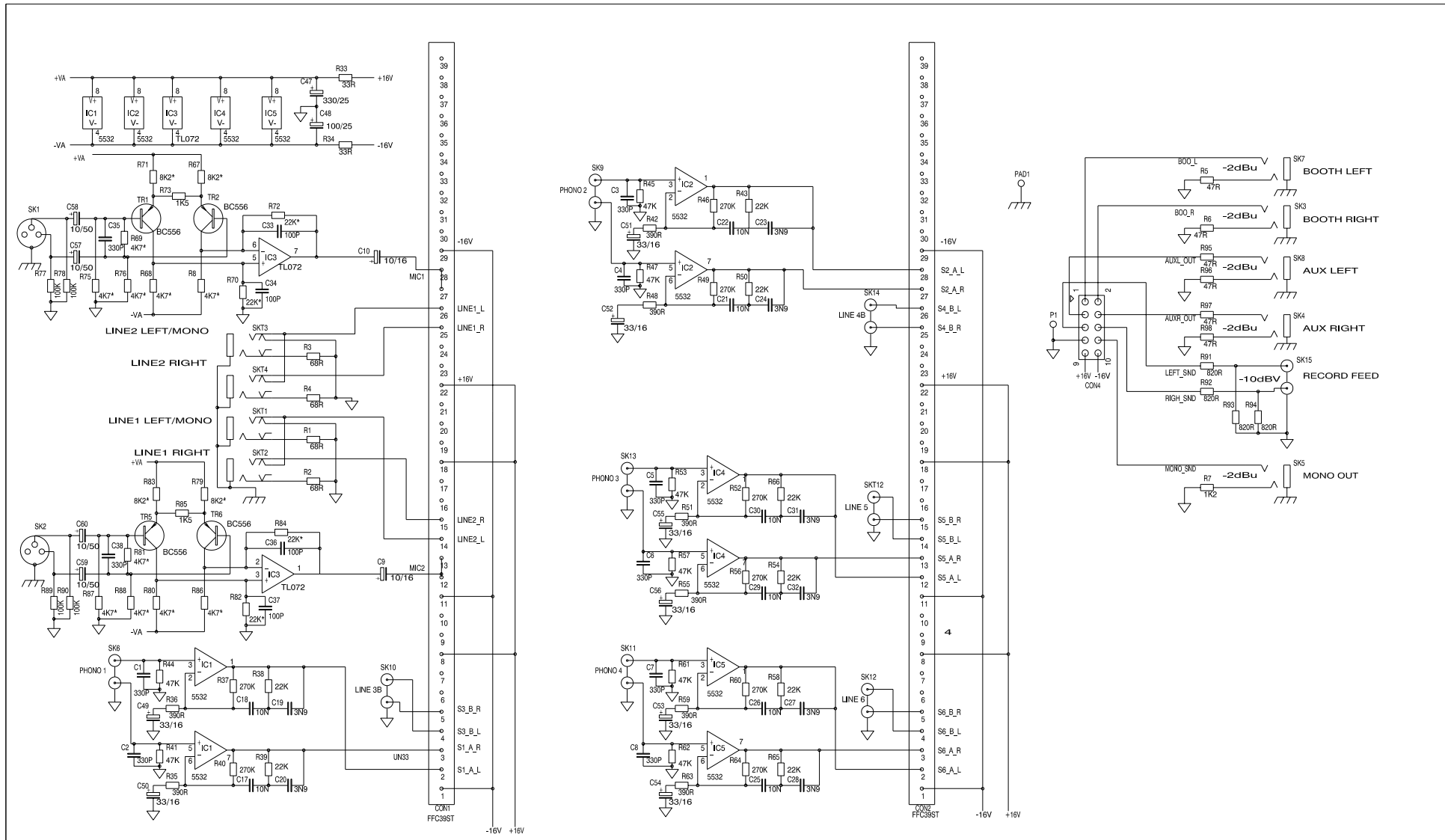

ISS.	REVISION	BY DATE
1	PRODUCTION	ARJ 23-8-99
1A	VALUE UPDATE	ARJ 21-10-99
2	C9/C10 ADDED	ARJ 2-12-99
2A	VALUE CHANGES	ARJ 31-10-00
3	FR4_DS_PCB	ARJ 19-03-01

ALLEN & HEATH
 Kernick Industrial Estate,
 Perryn, Cornwall,
 England, TR10 8LU
 Tel: (44) (0)870 7556250 Fax: (44) (0)870 7556251

XONE:62
CONNECTOR CIRCUIT
 C3726 issue 3

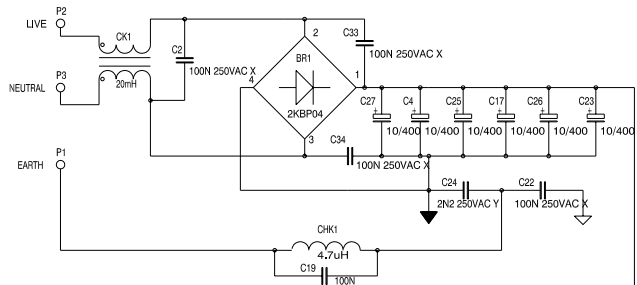

DANGER - HIGH VOLTAGE
DISCONNECT POWER BEFORE REMOVING PSU

REFER SERVICE WORK TO QUALIFIED SERVICE PERSONNEL ONLY

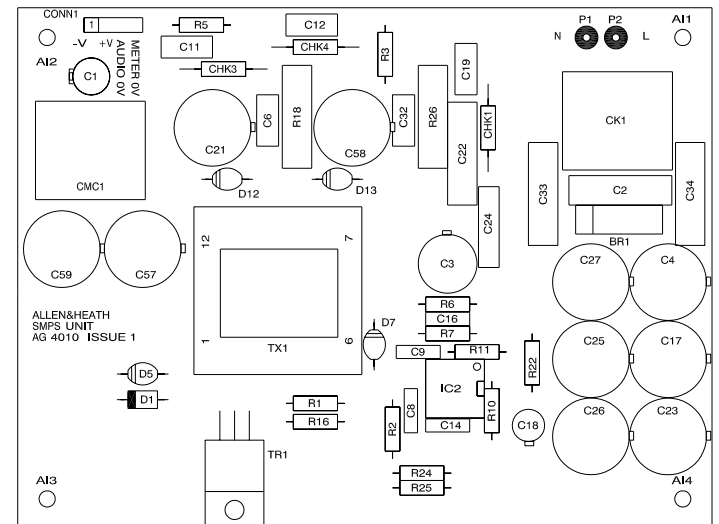
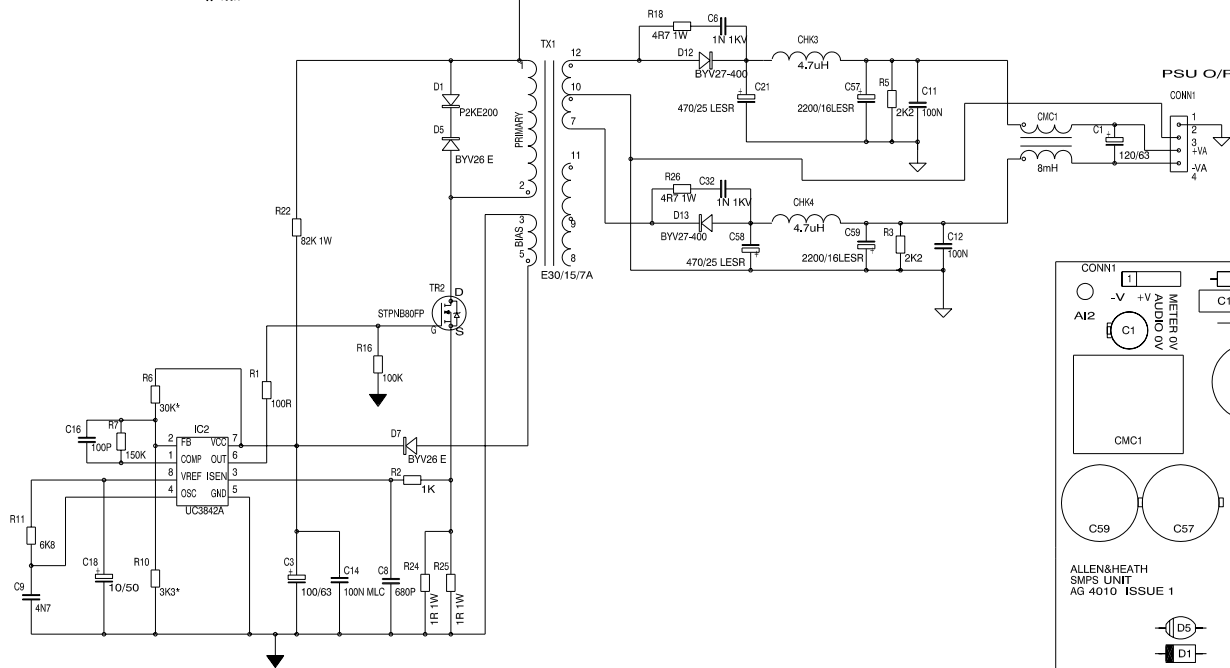

ISS.	REVISION	BY DATE
1	PRODUCTION	ARJ 27-9-00

ALLEN&HEATH
 Kernick Industrial Estate,
 Perryn, Cornwall,
 England, TR10 9LU
 Tel: (44) (0)870 756250 Fax: (44) (0)870 756251

XONE:62
PSU PCB & CIRCUIT - VERSION 2
 AG/C4010 issue 1

h
g
f
e
d
c
b
a

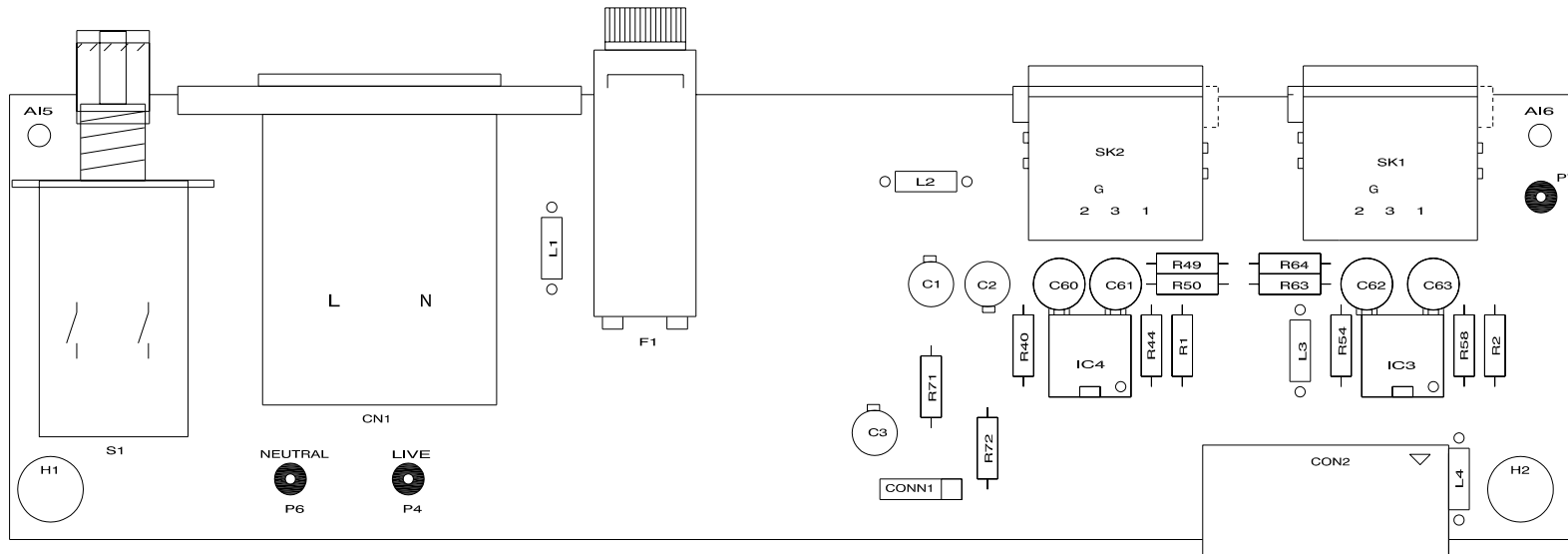
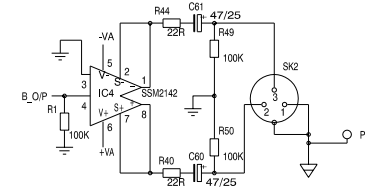
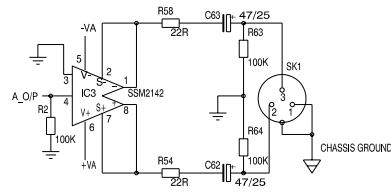
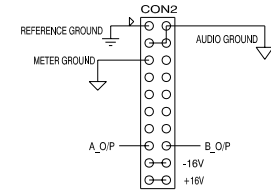
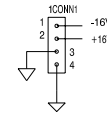
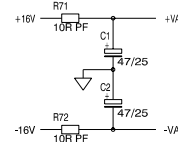
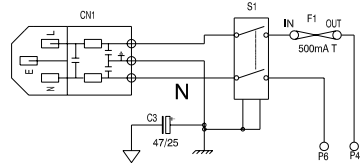

ISS.	REVISION	BY DATE
1	PRODUCTION	ARJ 28-09-00

ALLEN & HEATH
 Kernick Industrial Estate,
 Perryn, Cornwall,
 England, TR10 9LU
 Tel: (44) (0)870 7556250 Fax: (44) (0)870 7556251

XONE:62
MAINS PCB & CIRCUIT - VERSION 2
 AG/C4253 issue 1

h
g
f
e
d
c
b
a

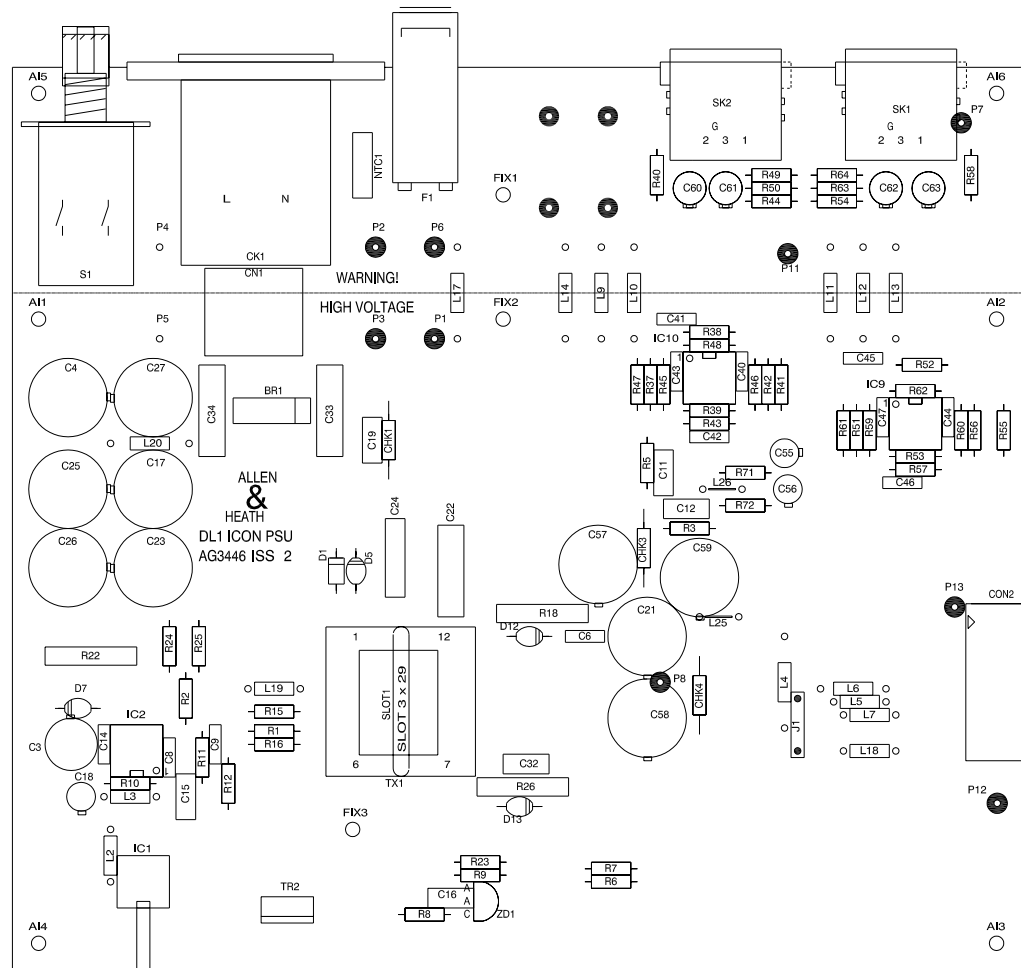

ALLEN & HEATH

Kernick Industrial Estate,
Penryn, Cornwall,
England, TR10 9LU
Tel: (44) (0)870 7556250 Fax: (44) (0)870 7556251

XONE:62
PSU PCB - VERSION 1
AG3446 issue2

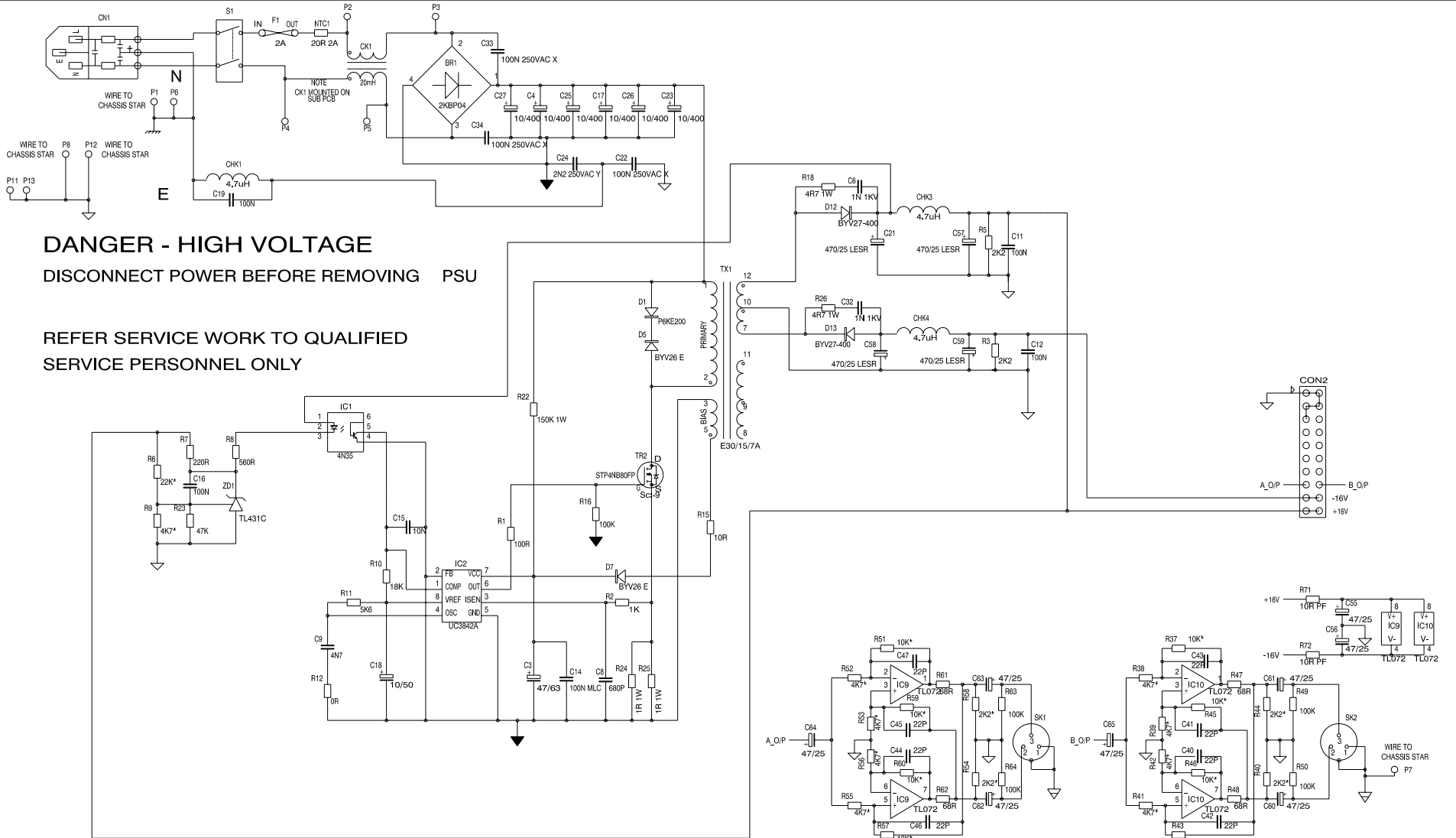

ISS.	REVISION	BY DATE
1	PRODUCTION EDIT	ARJ 20-8-99
2	OSCILLATOR VALUE CHANGE	DWD 15-11-99
2A	MOSFET VALUE CHANGE	ARJ 20-11-99

ALLEN & HEATH
 Kernick Industrial Estate,
 Penryn, Cornwall,
 England, TR10 9LU
 Tel: (44) (0)870 7556250 Fax: (44) (0)870 7556251

XONE:62
PSU CIRCUIT - VERSION 1
 C3446 issue 2A