

- I.F. - 465 KC.**
1. NUMBERS SHOWN RELATIVE TO PARTS ARE PART NUMBERS.
 2. NUMBERS SHOWN IN PARENTHESES ARE ILLUSTRATION NUMBERS.
 3. ⊕ INDICATES CAPACITY TOLERANCE ± 3%.
 4. ⊕ INDICATES CAPACITY TOLERANCE ± 10%.
 5. Ⓜ POUND JACK AND SWITCH ARE SPECIAL.
 6. DOTTED LINES SHOW CONNECTIONS.

VOLTAGE TABLE

SOCKET	DESCRIPTION	VOLTS
1	CONTROL GRID	0-250
2	SCREEN GRID	0-250
3	FLAMENT	0-250
4	FLAMENT	0-250
5	FLAMENT	0-250
6	FLAMENT	0-250
7	FLAMENT	0-250
8	FLAMENT	0-250
9	FLAMENT	0-250
10	FLAMENT	0-250
11	FLAMENT	0-250
12	FLAMENT	0-250
13	FLAMENT	0-250
14	FLAMENT	0-250
15	FLAMENT	0-250
16	FLAMENT	0-250
17	FLAMENT	0-250
18	FLAMENT	0-250
19	FLAMENT	0-250
20	FLAMENT	0-250
21	FLAMENT	0-250
22	FLAMENT	0-250
23	FLAMENT	0-250
24	FLAMENT	0-250
25	FLAMENT	0-250
26	FLAMENT	0-250
27	FLAMENT	0-250
28	FLAMENT	0-250
29	FLAMENT	0-250
30	FLAMENT	0-250

NOTE - 1. MEASURE ALL VOLTAGES (EXCEPT HEATERS & FILAMENT) BETWEEN SOCKET TERMINALS AND GROUND WITH A 1000 OHM PER VOLT VOLTMETER.
 2. MEASURE HEATER OR FILAMENT VOLTAGES DIRECTLY ACROSS HEATER OR FILAMENT SOCKET TERMINALS.

ALLIED RADIO CORP.

MODELS A9757, A9758
Chassis 76A
Socket, Trimmers
Layout

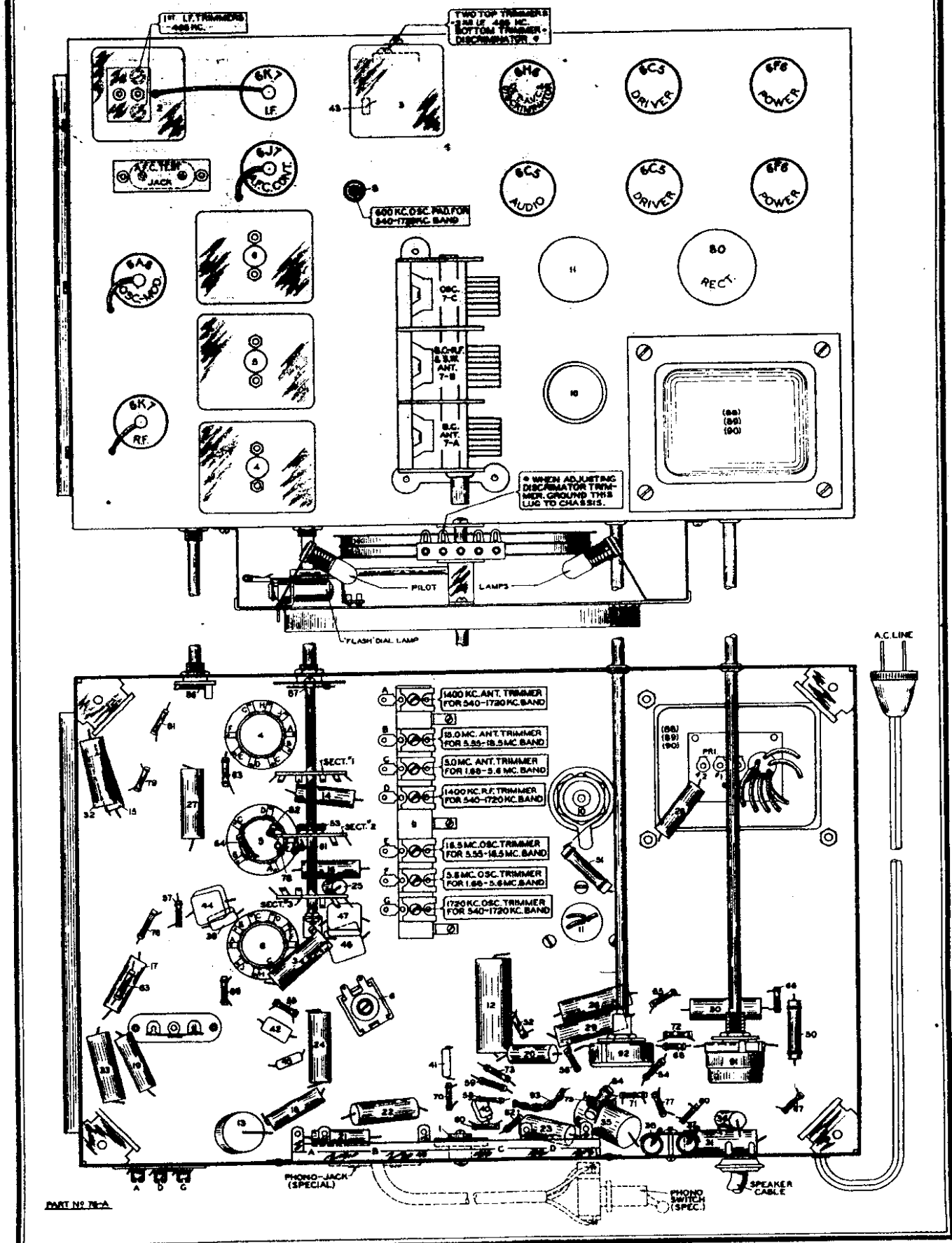

MODELS A9757, A9758
Chassis 76A
Alignment, Tuner

ALLIED RADIO CORP.

ALIGNMENT PROCEDURE

No. 76A

BEFORE REALIGNMENT BE NECESSARY, THERE ARE SEVERAL PRECAUTIONS THAT MUST BE CAREFULLY OBSERVED, THESE ARE:

1. Do not align set until it has reached normal operating temperature. Place the receiver in operation at least 15 minutes before attempting to realign the set.
2. The importance of using the proper type of test equipment and FOLLOWING THE ALIGNMENT PROCEDURE EXACTLY AS GIVEN CANNOT BE TOO STRONGLY EMPHASIZED—failure to do so will result in low sensitivity, poor selectivity, incorrect dial calibration, distortion and unsatisfactory operation of the automatic frequency control.
3. It is absolutely necessary that an accurately calibrated test oscillator with some type of output measuring device and a double scale milliammeter—0 to 1 M. A. and 0 to 5 M.A. be used.
4. To assure most accurate adjustment always carefully repeat all adjustments several times.
5. Once the alignment of the receiver has been completed, do not change the oscillator control tube, particularly with one of a different make.

(4) Place band selector switch for operation on 1720-540 K.C. broadcast band—and set receiver dial somewhere near 1600 kilocycles at a point where no station is heard.

(c) Rotate A.F.C. switch knob from A.F.C. "on" to A.F.C. "off" position and note whether the milliammeter reading changes as the position of the A.F.C. switch is changed. No change in reading indicates probable proper discriminator trimmer adjustment, while a noticeable change indicates improper discriminator trimmer adjustment.

IMPORTANT: DO NOT ADJUST DISCRIMINATOR TRIMMER UNLESS IT IS ABSOLUTELY NECESSARY. Place A.F.C. switch in A.F.C. "off" position and note milliammeter reading; then place A.F.C. switch in A.F.C. "on" position and CAREFULLY ADJUST DISCRIMINATOR TRIMMER UNTIL MILLIAMMETER READING IS EXACTLY THE SAME AS IT WAS WITH THE A.F.C. SWITCH IN THE "OFF" POSITION.

NOTE: As the discriminator trimmer screw is screwed in (increasing capacity) the milliammeter reading should decrease and as the discriminator trimmer is unscrewed (decreasing capacity) the milliammeter reading should increase. IF WHEN ADJUSTING THE DISCRIMINATOR TRIMMER THE MILLIAMMETER READING DOES NOT SHARPLY INCREASE OR DECREASE AS THE TRIMMER IS ADJUSTED EVEN AFTER SEVERAL TURNS OF THE TRIMMER SCREW, THIS DOES NOT INDICATE PROPER BALANCING BUT DOES INDICATE INCORRECT ADJUSTMENT AND THE DISCRIMINATOR TRIMMER SHOULD BE SET TO ABOUT 1/2 CAPACITY AND THE ADJUSTMENT OF THE DISCRIMINATOR TRIMMER MADE ALL OVER AGAIN.

(a) Dirt or corrosion on contact surface of tab holder or rail.
(b) The rail to which the metal tab holders are clipped may be sprung forward preventing contact between the mute switch and the metal tab holder.
To determine whether the cause is due to poor contact, press lightly around the contact surface of the rail and if the motor clearly is a positive indication that the rail will have to be bent in slightly or—the contact surface of the metal holder is dirty or—the mute switch tension spring is bent back or has lost its resiliency.
If the rail requires adjustment place thumbs near the upper right and left ends of the rail and press slightly inward until naturally come forward slightly after pressure is released. Do not attempt to force the rail inward with too much pressure at one time. Several adjustments are better than extreme force which would cause the opaque screen to break.
If the metal tab holders move as the tuning lever is rotated, the tabs have probably been sprung, which can be corrected by adjusting the spring tension. Carefully adjust the metal tab with a pair of long nose pliers so as to make contact between the rear contact portion of the metal tab and the front portion.

ALIGNING I.F. STAGE AT 465 KILOCYCLES:

- Place automatic frequency control in the maximum left hand A.F.C. "off" position.
- Attach the ground lead of the test oscillator to the chassis. Connect the other lead to the grid cap of the 6AS tube through a .02 Mfd. series condenser. DO NOT REMOVE GRID CLIP.
- Set test oscillator to EXACTLY 465 kilocycles and turn volume control on full.
- Remove shields held in position by snap fasteners over A.F.C. test jack and over trimmer screw holes in the first and second I.F. transformer shield cans.
- Peak second I.F. transformer trimmers for maximum 465 kilocycle output by adjusting the two trimmers accessible through the two top holes in the second I.F. transformer shield can. DO NOT TOUCH DISCRIMINATOR (BOTTOM) SCREW.
- Peak each of the first I.F. transformer trimmers for maximum 465 kilocycle signal output.

ALIGNING 1.69-5.6 MEGACYCLE BAND:

- Replace .00025 Mfd. test oscillator antenna lead series condenser with a 400 ohm resistor.
- Adjust band selector switch to 1.69-5.6 megacycles, tune receiver dial and set test oscillator frequency to EXACTLY 5.6 megacycles. Bring in 5.6 megacycle test signal to maximum output by adjusting 5.6 M.C. oscillator trimmer.
- Tune receiver dial and test oscillator frequency to EXACTLY 5 Megacycles and adjust 5 M.C. antenna trimmer for maximum sensitivity.

ALIGNING 5.55-18.5 MEGACYCLE BAND:

- Leave 400 ohm resistor in series with test oscillator lead and place band selector switch for operation on 5.55-18.5 megacycle band, tune receiver dial and set test oscillator frequency to EXACTLY 18.5 megacycles.
- Adjust 18.5 M.C. oscillator trimmer to bring in 18.5 megacycle test signal to maximum output.

NOTE: When adjusting this trimmer two peaks, the fundamental and the image peak will be noticed. CARE MUST BE TAKEN THAT THE FUNDAMENTAL PEAK AND NOT THE IMAGE PEAK IS USED FOR ALIGNING THE RECEIVER AT 18.5 MEGACYCLES. Always back off the trimmer to minimum capacity, then screw down the trimmer (add capacity) until the FIRST peak which is the fundamental and the proper one to use is tuned in. If the trimmer is screwed down beyond the point where the first peak is received the incorrect image peak will be tuned in. After completing adjustment of the oscillator trimmer at 18.5 megacycles, always check to see if the proper peak has been used. To do this leave test oscillator frequency at 18.5 megacycles, increase the output of the test oscillator and tune receiver dial to approximately 17.5 megacycles. Then vary the receiver dial slightly to the right and left of 17.5 megacycles, and if the fundamental peak was used in aligning at 18.5 megacycles the test oscillator signal will be heard at approximately 17.5 megacycles on the receiver dial.

ALIGNING 1720-540 KILOCYCLE BAND:

- Check tuning dial adjustment by turning gang condenser until plates touch maximum capacity stop (completely in mesh), at which point the dial needle must be exactly even with the last line at the low frequency end of the dial calibration. If the dial needle does not point exactly to the last line, move needle to correct position.
- Remove test oscillator lead from grid of 6AS tube and connect to receiver "A" antenna post through a .00025 Mfd. condenser.
- Adjust A.F.C. control to maximum left hand A.F.C. "off" position and band selector switch for operation on the 1720-540 kilocycle band.
- Set test oscillator frequency and receiver dial to EXACTLY 1720 kilocycles, and BRING IN 1720 KILOCYCLE TEST OSCILLATOR SIGNAL TO MAXIMUM OUTPUT BY ADJUSTING 1720 KILOCYCLE OSCILLATOR TRIMMER.
- Tune receiver dial and set test oscillator frequency to EXACTLY 1400 kilocycles. Adjust 1400 K.C. R.F. and antenna trimmers for maximum sensitivity.
- Set test oscillator frequency and receiver dial to approximately 600 kilocycles. Then while rocking gang condenser slightly to right and left, adjust 600 K.C. oscillator padder for maximum signal response.

- Tune receiver dial and set test oscillator frequency to EXACTLY 15 megacycles.
- Rock gang condenser slightly to right and left and adjust 15 M.C. antenna trimmer for maximum 15 megacycle test signal response.

To assure more accurate trimmer setting, repeat all above adjustments several times always using lowest possible test oscillator output consistent with readable output meter scale deflection.

ALIGNING DISCRIMINATOR CIRCUIT:

- After completing 1720-540 kilocycle adjustment, set test oscillator to EXACTLY 465 KILOCYCLES and connect to grid of 6AS tube through a .02 Mfd. Condenser—insert lead of double scale 0 to 1 and 0 to 5 milliammeter into A.F.C. test jack located on top of chassis adjacent to the 6L7 tube. To avoid possibility of damaging the meter should one of the milliammeter leads short to the metal chassis, ALWAYS TURN OFF RECEIVER WHEN INSERTING OR REMOVING MILLIAMMETER LEADS FROM A.F.C. TEST JACK.
- Short out A.F.C. mute switch by grounding the second from the left (looking at the front of the chassis) of the four lugs mounted on top of the dial assembly. The proper lug to ground is indicated in the "Note X" on chassis top plate view.
- Turn receiver on, place A.F.C. switch knob in A.F.C. "on" position and if meter needle jumps off scale adjust output of test oscillator until an approximate 2 M.A. deflection is obtained on the 0 to 5 milliammeter scale.

"Automatic-Flash" tuning

- Lay station call letter tab sheet on flat surface and with razor or sharp knife cut out desired tabs by cutting around the black edges of each required station tab.
- Unscrew the two knurled head screws mounted on front of the glass frame and then holding onto the screws pull dial glass away from the cabinet.
- To illustrate the proper setting and installation of the metal holder and station call letter tabs, the receiver is shipped from the factory with a tab properly set for Station WGN 720 kilocycles. Carefully study the way the call letter tab and celluloid envelope is inserted in the metal holder, and if WGN is not one of the selected stations, remove WGN celluloid envelope and call letter tab by sliding the celluloid envelope out through the top of the metal holder. See "B" in diagram.

IF THE CALL LETTER TAB IS ILLUMINATED AND THE STATION IS NOT HEARD, OR IF THE SIGNAL IS DISTORTED, THE METAL TAB HOLDER IS INCORRECTLY SET AND HOW IT WILL BE NECESSARY TO MAKE THE CORRECT POSITION. See paragraphs 5 and 6 for proper procedure.
After metal holder is properly adjusted for the selected station operating on the test frequency, set a station call letter tab in the holder, continuing on in this way until a tab holder is set for all the selected stations.
After the call letter tab holders are adjusted as that when the station is tuned in with greatest clarity the light in back of the call letter tab illuminates the tab, the adjustment of the tabs is completed and thereafter will require no attention except when moved from their position by tampering or when an additional station tab is included which would disturb the position of the other tabs.
NOTE: A distorted signal and microphone sound that is caused by the station call letter tab being illuminated in the A.F.C. switch is in the A.F.C. "off" position is generally caused by the mute switch contact not making good contact to the metal tab holder due to:

1. The Automatic Frequency and Inter-Station Noise Filter Control tube which is "Automatic" in position.
2. The station call letter tab is not properly set for the station frequency.
3. The station call letter tab is not properly set for the station frequency.
4. Control to maximum left hand position.
5. As it is desirable to begin setting metal tab holders at the low frequency end of the broadcast band (40 Kilocycles) the frequency of the test oscillator should be set to indicate on the lowest frequency—least number of kilocycles.
6. By using the metal holder tool (see "A" in diagram) or by grasping with the finger tips, carefully slide the metal holder which has the celluloid envelope attached to it, along the metal rail to which the metal holders are clipped... until a narrow light appears directly below the metal tab holder being adjusted.
Place paper tab having call letters and frequency of station tuned in inside of celluloid envelope... insert the celluloid envelope with curved end of the tab... into the top of the envelope... and... release down until the curved end of the celluloid envelope fits into the curved top of the metal holder.
7. Turn Automatic Frequency and Inter-Station Noise Filter Control tube which is "Automatic" in position.
Slide the station call letter tab into the metal holder and set it so that the station call letter tab is in the A.F.C. switch in the A.F.C. "off" position and if the metal tab holder is properly set, the station call letter tab will be illuminated at approx.

Dial Assembly, Parts Data

ALLIED RADIO CORP.

MODELS A9757, A9758
Chassis 76A

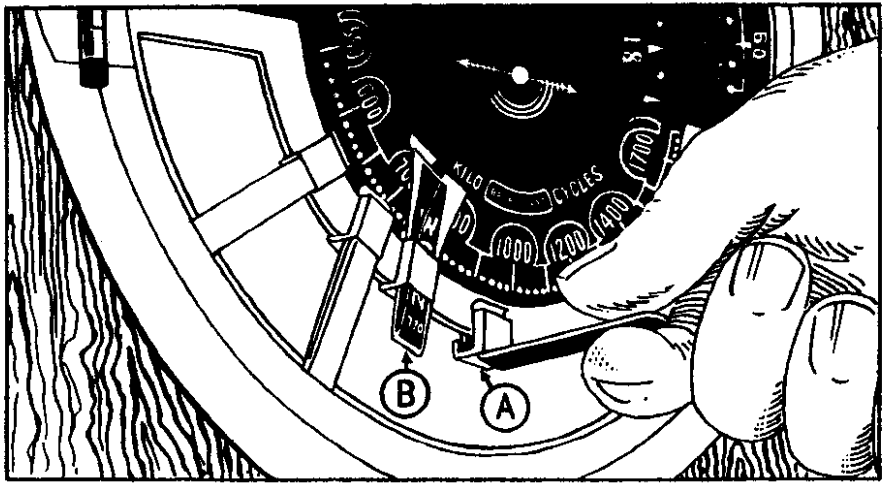
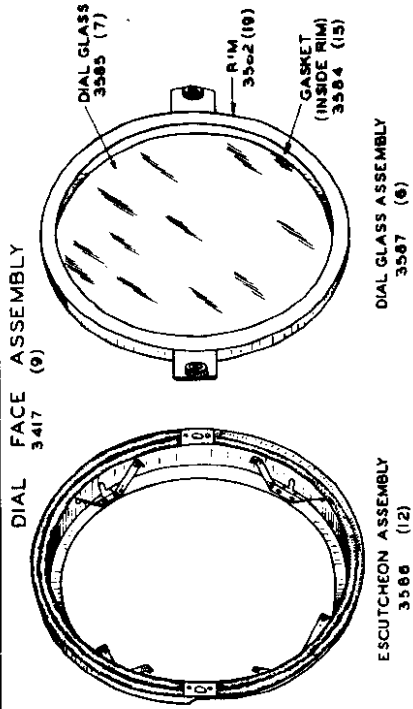

PROCEDURE FOR REMOVING RECEIVER FROM CABINET.

1. Unscrew the two knurled head screws mounted on front of the glass frame and then holding onto the screws pull dial glass away from the cabinet.
2. Swing 'rapid tuning' lever to center position as shown, loosen (do not remove) screw thru hole in bottom center, and remove lever knob.
3. Loosen set screws on all five tuning knobs, and remove knobs from shafts. (Not shown in sketch).
4. Remove four bolts at bottom side of chassis mtg. shelf (not shown in sketch.)
5. Remove wood screws on the pressure brackets at rear of chassis (not shown in sketch) and then slide receiver out of cabinet.
6. When replacing receiver in cabinet, reverse entire procedure given above.

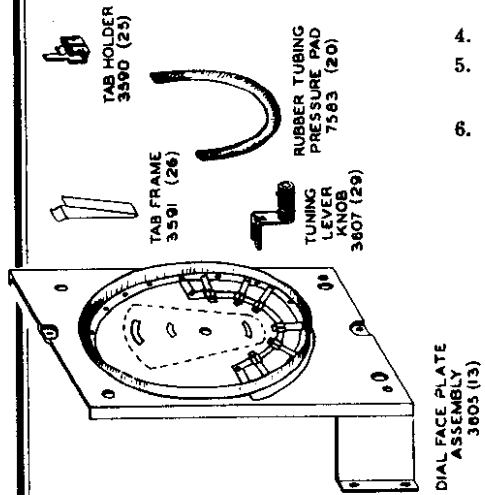

NOTES -
1. NUMBERS SHOWN RELATIVE TO PARTS ARE PART NUMBERS.
2. NUMBERS SHOWN IN PARENTHESES ARE ILLUSTRATION NUMBERS.

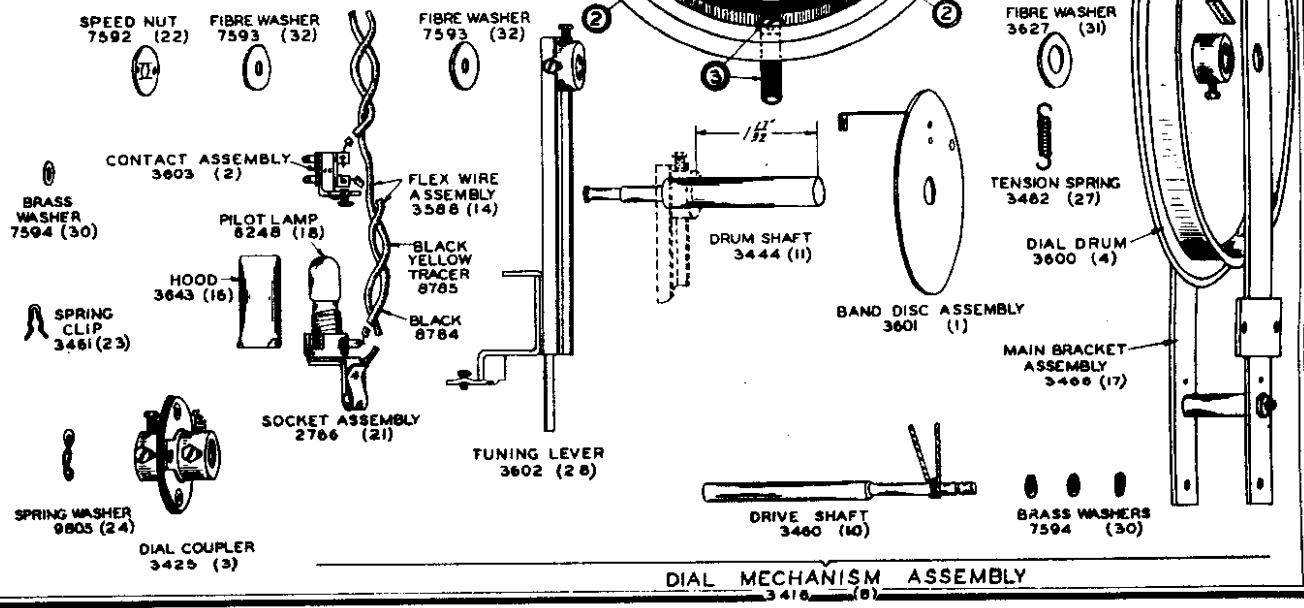

MODELS A9757, A9758
Chassis 76A
Parts

ALLIED RADIO CORP.

PARTS LIST

DIAL PARTS

Part No.	Part Name	Description	List Price
47	1628	Condenser	.21
48	3392	Resistor	1.15
49	3413	Resistor	.20
50	3414	Resistor	.20
51	3414	Resistor	.19
52	1942	Resistor	.19
53	1944	Resistor	.19
54	1944	Resistor	.19
55	1977	Resistor	.19
56	3410	Resistor	.19
57	3410	Resistor	.19
58	3610	Resistor	.19
59	7998	Resistor	.19
60	6984	Resistor	.19
61	6984	Resistor	.19
62	8906	Resistor	.19
63	8906	Resistor	.19
64	8906	Resistor	.19
65	8906	Resistor	.19
66	8906	Resistor	.19
67	8906	Resistor	.19
68	2155	Resistor	.19
69	8000	Resistor	.19
70	8000	Resistor	.19
71	8000	Resistor	.19
72	3534	Resistor	.19
73	6879	Resistor	.19
74	6879	Resistor	.19
75	8907	Resistor	.19
76	8907	Resistor	.19
77	8907	Resistor	.19
78	9460	Resistor	.19
79	7097	Resistor	.19
80	9706	Resistor	.19
81	1562	Resistor	.19
82	1562	Resistor	.19
83	1152	Resistor	.19
84	5412	Resistor	.19
85	2730	Speaker	11.00
86	3405	Switch	.45
87	3406	Switch	2.00
88	3394	Transformer	5.75
89	3395	Transformer	5.75
90	3396	Transformer	8.50
91	3404	Tone Control	1.20
92	3403	Volume Control	1.00
93	3662	Condenser	1.00
	*3738	Coil	2.75

Part No.	Part Name	Description	List Price
18	6248	Pilot Light	.17
19	3582	Rim	.65
20	7283	Rubber Tubing	.35
21	*42751	Socket Assembly For "Flash" Pilot Light	.20
22	7292	Speed Nut	Hd. 2.25
23	3461	Spring Clip	Hd. 7.50
24	9805	Spring Washer	Hd. 3.25
25	3590	Tab Holder	.08
26	3591	Tab Frame	.04
27	3462	Tension Spring	.07
28	3602	Tuning Lever	.50
29	3607	Tuning Lever	.30
30	7594	Washers, Brass	Hd. .75
31	3627	Washer, Fibre	Hd. .75
32	7593	Washers, Fibre	Hd. .75

MISCELLANEOUS PARTS LIST

Part No.	Part Name	Description	List Price
3089	Arm	Wave Switch	.06
3663	Cover	Meter Jack	.06
3666	Cover	2nd I.F. Trimmer Shield	.04
3665	Cover	1st I.F. Trimmer Shield	.03
3612	Guide Bracket	Chassis Right Hand	.05
3613	Guide Bracket	Chassis Left Hand	.05
2534	Knob	Marked "Tuning"	.30
2444	Knob	Marked "Volume"	.30
2535	Knob	Marked "Tone-On-Off"	.30
2445	Knob	Marked "Band Selector"	.30
3422	Knob	Marked "A.F.C."	.30
3436	Link	Wire Connecting for Arm	.04
3393	Meter Jack		.30
2953	Strip	Antenna and Ground Post	.25
3667	Snap Fastener	For Meter Jack & I.F. Transformer Shields	.30

Prices are subject to change without notice

NOT SHOWN IN ASSEMBLIES

Part No.	Part Name	Description	List Price
3592	Tab Tool	Dial Needle	.20
3392	Tab Sheets	Inserting Tool	.05
		Call Letter Sheet No. 1 and No. 2, Net, Set	.25

Note * 3463 Appears as 3643 on dial part diagram.
Note ** 3751 Appears as 2766 on dial part diagram.