

ALLIED RADIO CORP.

MODELS A9775, A9860
Chassis B1
Schematic, Socket
Trimmers, Alignment

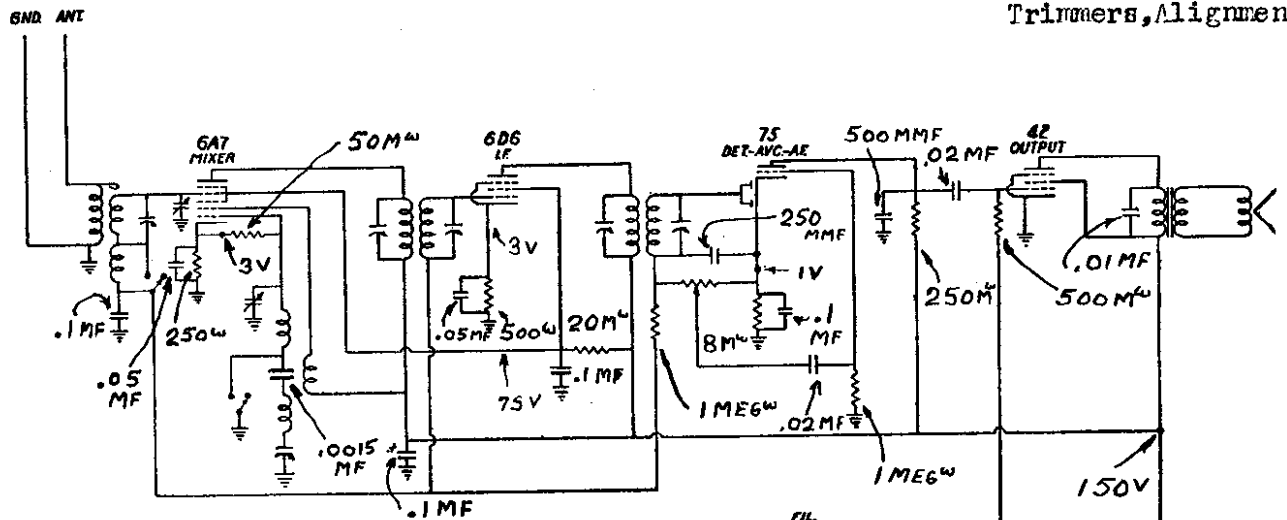

SCHEMATIC DIAGRAM
B1 CHASSIS
5 TUBE A.C. 2 BAND [BC-340 TO 1720 K.C.
S.W-2000 TO 7000 K.C.
I.F. = 456 K.C.
SWITCH SHOWN IN B.C. POSITION
ALL VOLTAGES SHOWN TO GROUND

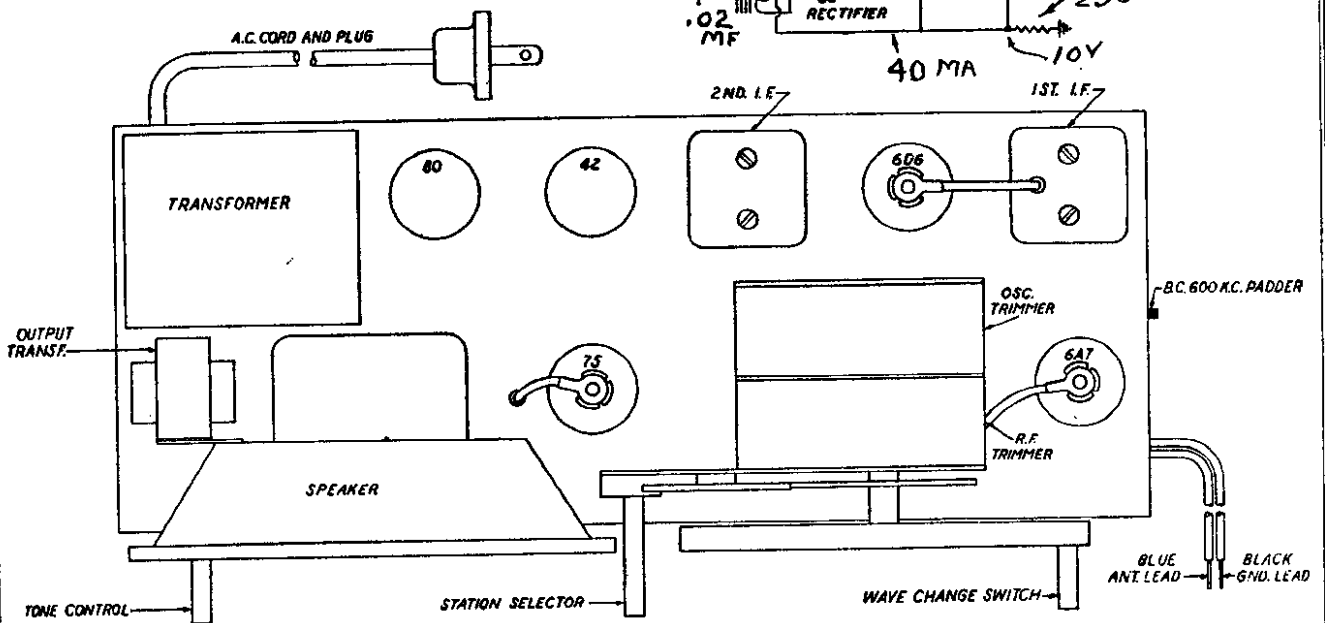

ALIGNMENT

INTERMEDIATE FREQUENCY - Connect the Signal Generator to grid of 6A7 tube through a .05 MFD condenser. Ground Generator to Ground of chassis. Set Generator at 456 KC and adjust trimmers on IF transformers for Max. Peak.

BROADCAST BAND - Connect the Generator to the antenna of receiver through a 1000MFD condenser. Ground Generator to ground of chassis. Range switch in Broadcast position. Set Generator to 1400 KC and adjust Oscillator and RF trimmers to maximum peak. Dial of receiver set on 1400 KC. Pad the Broadcast band at 600 KC, rocking gang condenser during the adjustment.

SHORT WAVE BAND - Set Receiver and Generator to 6000 KC. Range switch in SW position. Adjust SW antenna trimmer for maximum peak. No padding adjustment is required on this band.