

SERVICE MANUAL **ALPINE**

AL-61

STEREO CASSETTE DECK

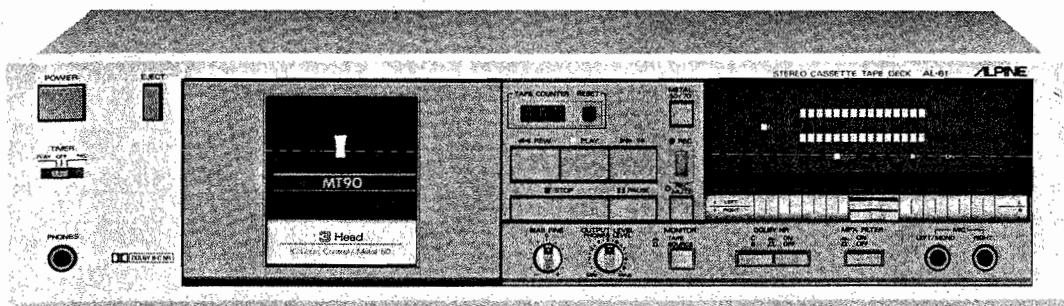

ALPINE

Contents

Specifications	2
Parts Locations and Disassembly Instructions	3 to 5
Replacement of Mechanical Parts	6 to 7
Block Diagram	8
Packing Assembly Parts List	9
Packing Method View.	9
Adjustment Procedures.	10 to 12
Adjustment Locations	13 to 14
Parts Layout on P.C. Board	15 to 21
Wiring Diagram	22 to 23
Schematic Diagram	24 to 26
Electrical Parts List	27 to 37
Cabinet Assembly Parts List	38
Exploded View (Cabinet)	39 to 40
Exploded View (Cassette Deck)	41 to 42
Cassette Deck Assembly Parts List	43
Semi-Conductor Lead Identifications	44 to 45

Specifications

Power Source	120V, 220 ~ 240V, AC 50/60 Hz
Power Consumption.	35W
Tape Speed	4.76 cm/sec. $\pm 1.5\%$
Wow & Flutter (JIS WRMS Playback Mode)	0.05%
FF/REW Time (C-60).	100 sec.
Frequency Response	Norm: 30 Hz ~ 17 kHz, CrO ₂ : 30 Hz ~ 18 kHz, Metal: 30 Hz ~ 19 kHz
Rec/Play Head	Two gaps combination ferrite and hard permalloy core
Erase Head.	Double gaps ferrite core
Load Impedance	Line Out: 100K ohm, Head Phone: 8 ohm
S/N Ratio	NR-Off: Norm 55 dB, CrO ₂ /Metal: 57 dB NR-B: Norm: 57 dB, CrO ₂ /Metal: 59 dB, Metal 50: 61 dB NR-C: Norm: 63 dB, CrO ₂ /Metal: 65 dB, Metal 50: 67 dB
Input Sensitivity	Mic: 0.3mV Line: 100mV
Output Level	Line Out: 500mV ± 1.5 dB, Head Phone: 65 mV
Stereo Separation	35 dB
Distortion	3%
Semiconductors	7 IC's, 72 Transistors, 40 Diodes, 10 Zener Diodes, 6 FETs
Dimensions	435(W) x 111(H) x 250(D) mm
Weight.	4.5 Kg

Parts Locations and Disassembly Instructions

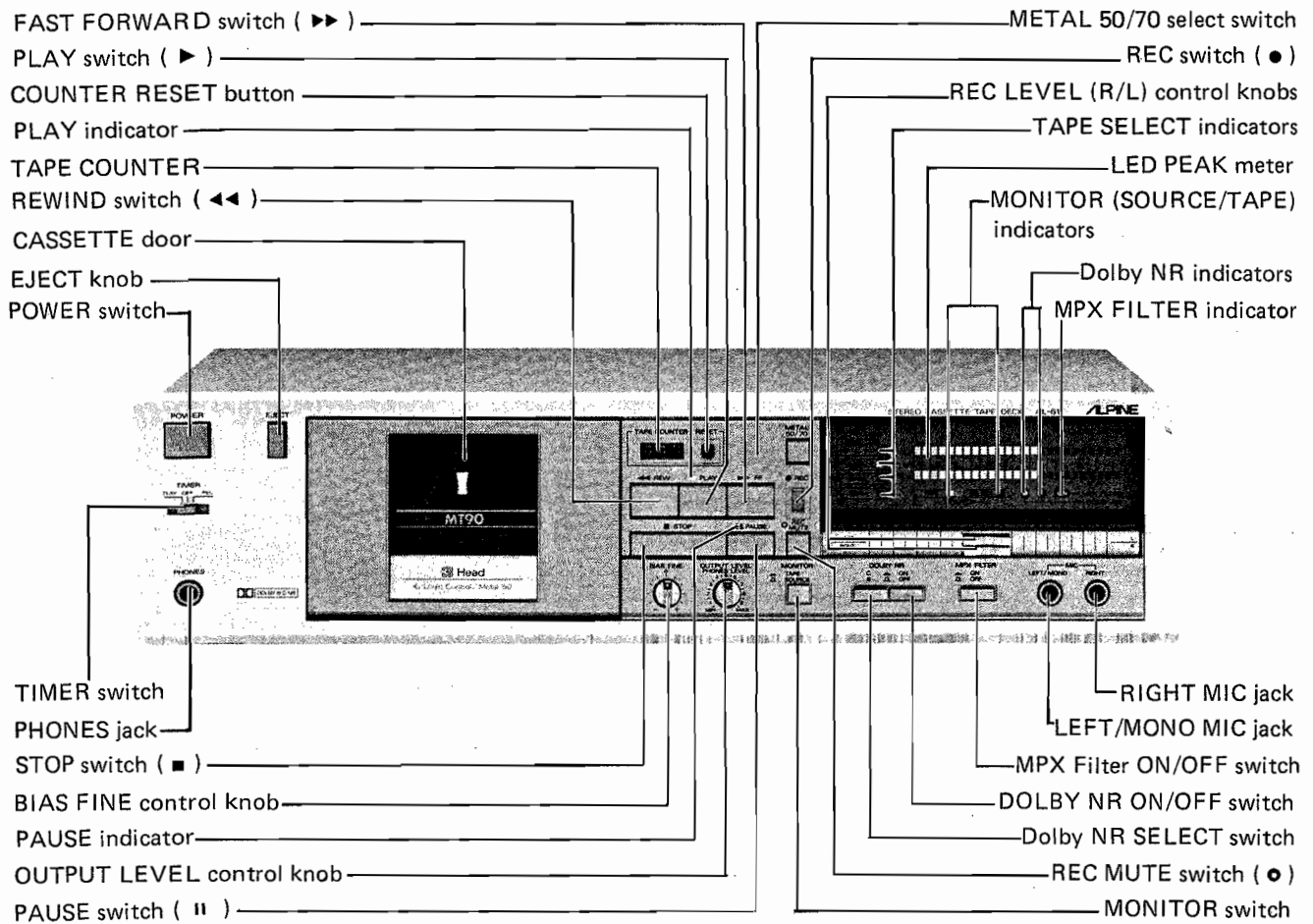

Figure 1

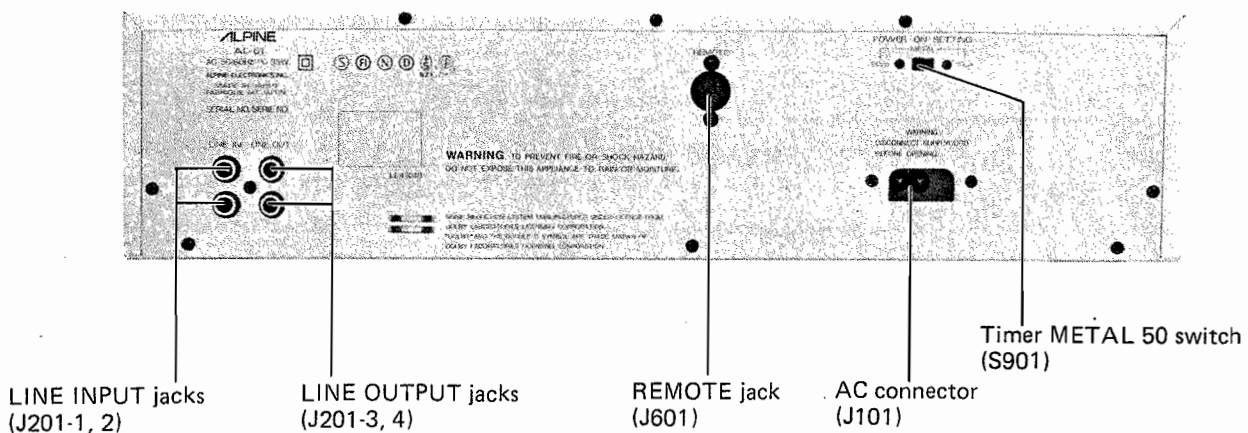

Figure 2

1. Removal of Top Cover

- (1) Remove eight screws marked "○" as shown in Figures 3 and 4.
- (2) Lift up the top cover in the direction of the arrow as shown in Figure 3.

2. Removal of Front Panel

- (1) After removal of top cover, remove six screws marked "☆" as shown in Figures 4 and 5.

3. Removal of Rear Cover

- (1) After removal of top cover, remove ten screws marked "■" as shown in Figure 4.
- (2) Remove two tacks as shown in Figure 4.

4. Removal of Front Escutcheon

- (1) After removal of front panel, remove a screw marked "◇" as shown in Figure 6.
- (2) Remove two knobs as shown in Figure 6.
- (3) Remove hooks (1) as shown in Figures 5 and 6.
- (4) Disconnect all wires from the key board switch P.C. Board.
- (5) Then remove the front escutcheon with the key board switch P.C. Board.

5. Removal of Key Board Switch P.C. Board

- (1) After removal of front escutcheon, remove six screws marked "□" as shown in Figure 7.

6. Removal of Meter P.C. Board

- (1) After removal of front escutcheon, remove a screw marked "★" as shown in Figure 8.
- (2) Remove hooks (2) as shown in Figures 5 and 8.
- (3) Remove the meter frame.
- (4) Remove two screws marked "▲" as shown in Figure 8.
- (5) Disconnect all wires from the meter P.C. Board.

7. Removal of Side Chassis R and Bottom Cover

- (1) After removal of rear cover, remove two screws marked "※" as shown in Figure 6.
- (2) Remove the bottom cover,
- (3) Remove a screws marked "◆" as shown in Figure 6.

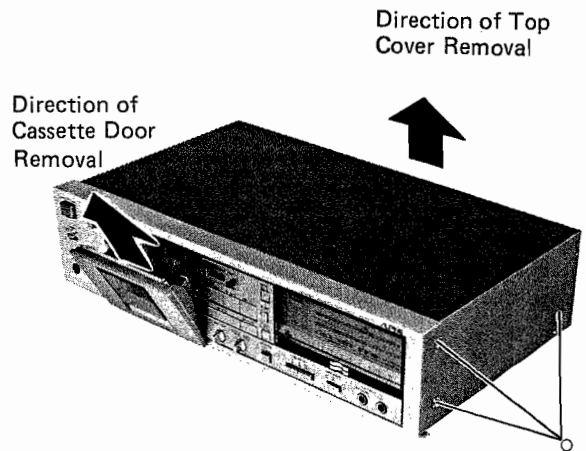

Figure 3

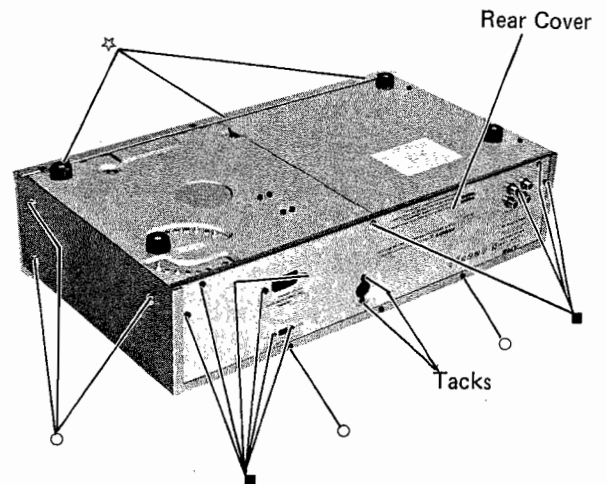

Figure 4

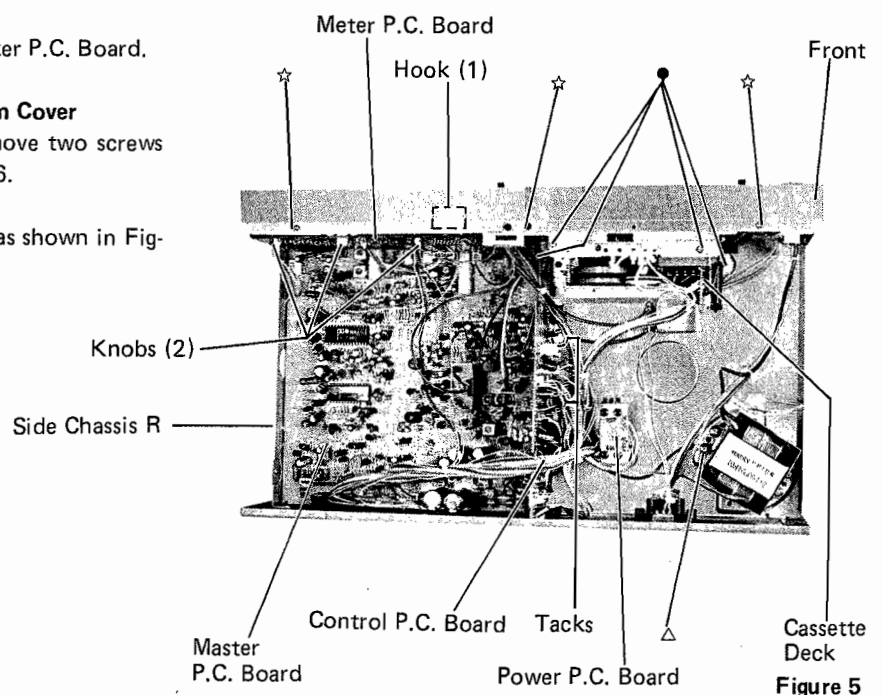

Figure 5

8. Removal of Master P.C. Board

- (1) After removal of rear cover, side chassis R and meter P.C. Board, remove two nuts, washers and stoppers as shown in Figure 8.
- (2) Remove three screws marked "△" as shown in Figures 5 and 8.
- (3) Remove four switch knobs as shown in Figure 8.
- (4) Disconnect all wires from the Master P.C. Board.

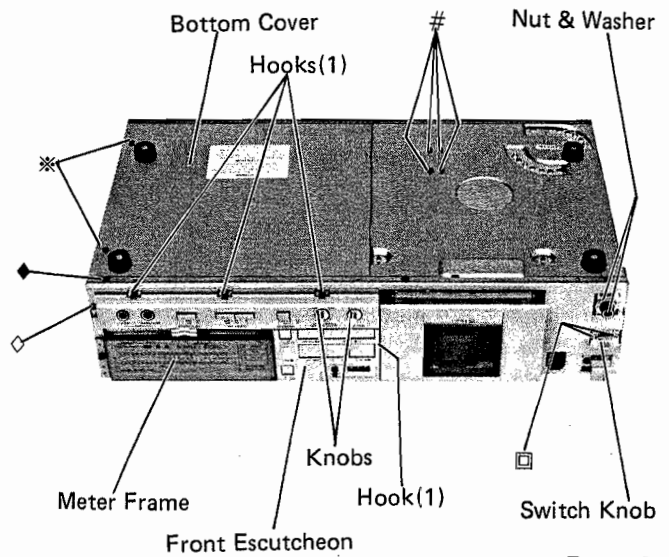

Figure 6

9. Removal of Cassette Deck

- (1) After removal of top cover, remove cassette door upward as shown in Figure 3.
- (2) Remove four screws marked "●" as shown in Figure 5.
- (3) Disconnect all wires from the cassette deck.
- (4) Remove the belt from the tape counter.

10. Removal of Headphone and Timer P.C. Boards

- (1) After removal of front panel, remove a switch knob as shown in Figure 6.
- (2) Remove two screws marked "□" as shown in Figure 6.
- (3) Remove a nut and a washer as shown in Figure 6.
- (4) Disconnect all wires from the P.C. Board.

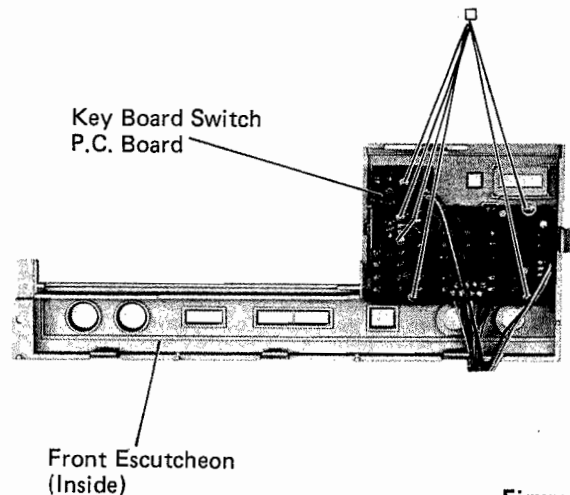

Figure 7

11. Removal of Power P.C. Board

- (1) After removal of top cover, remove four screws marked "#" as shown in Figure 6.
- (2) Disconnect all wires from the P.C. Board.

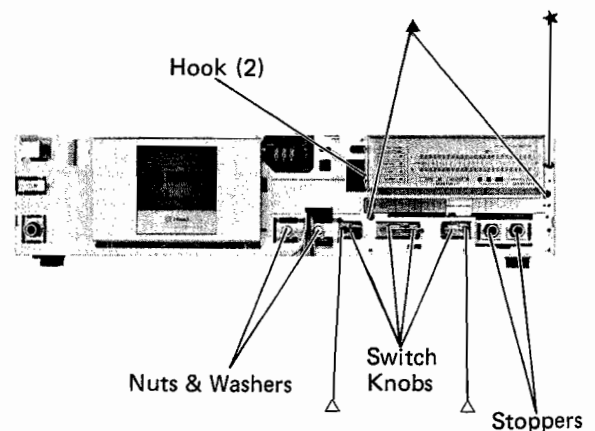

Figure 8

12. Removal of Control P.C. Board

- (1) After removal of rear cover, remove two tacks as shown in Figure 5.
- (2) Disconnect all wires from the P.C. Board.

Replacement of Mechanical Parts

Removal of Cassette Deck

Prior to Replacement Procedures, remove the cassette deck assembly according to "Removal of Cassette Deck" on page 5.

Replacement of Head

- (1) Remove two screws marked "★" from the cassette door bracket of the cassette deck as shown in Figure 9 and the cassette door can be removed.
- (2) Remove four screws marked "○" and wires from both sides of the R/P head "A", as shown in Figure 10, and it can be removed, with head P.C. Board. Remove the head from the P.C. Board with a soldering iron. Remove two screws marked "●" and wires from both sides of the erase head "B" as shown in Figure 10, and it can be removed.
- (3) After finishing assembling, adjust head azimuth, height and tilt angle. Apply screw-lock after adjustment.

Replacement of Belt and Flywheel

- (1) Remove a screw marked "□" and the motor bracket, and two belts can be removed as shown in Figure 11.
- (2) Remove a washer marked "△" as shown in Figure 13 and the flywheel can be removed.
- (3) After replacing the belt and flywheel, clean them with absolute alcohol.
- (4) After finishing assembling, confirm tape speed and wow/flutter with test tape (MTT-111).

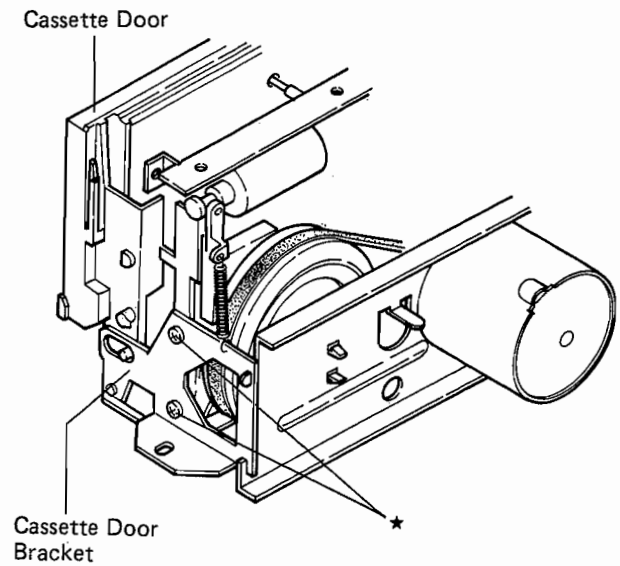

Figure 9

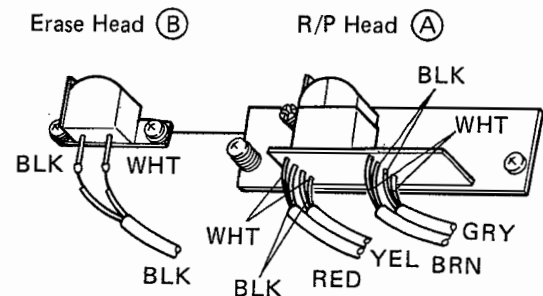
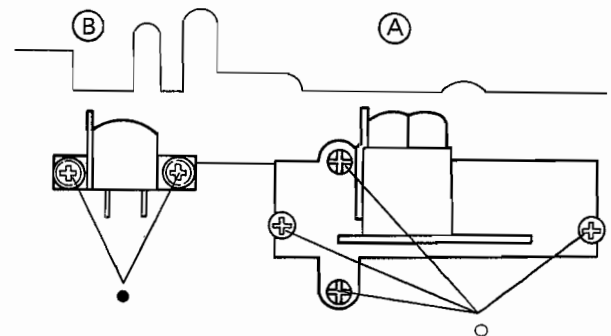

Figure 10

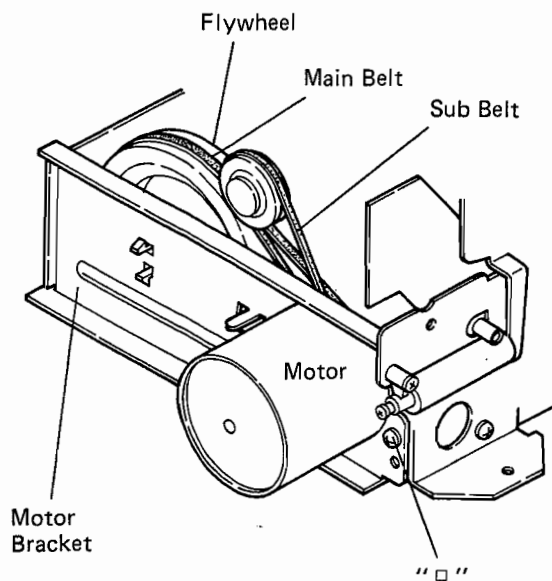

Figure 11

Replacement of Motor

- (1) Remove a screw marked "□" as shown in Figure 11 and two screws marked "☆" and two wires (white, white/pink from connector as shown in Figure 12, and the motor can be removed.
- (2) After finishing assembling, confirm tape speed and wow/flutter with test tape (MTT-111).

Replacement of Pinch Roller

- (1) Remove a washer marked "▲" to take off pinch roller assembly from the cassette deck as shown in Figure 13.
- (2) After replacing the pinch roller, clean it with absolute alcohol.
- (3) After finishing assembling, confirm tape speed and wow/flutter with test tape (MTT-111).

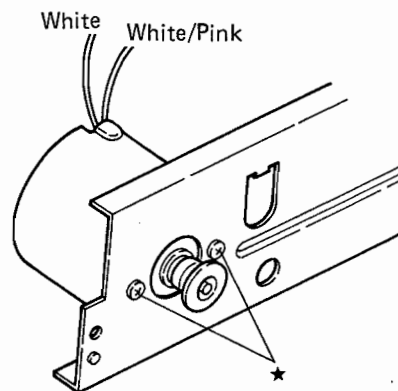

Figure 12

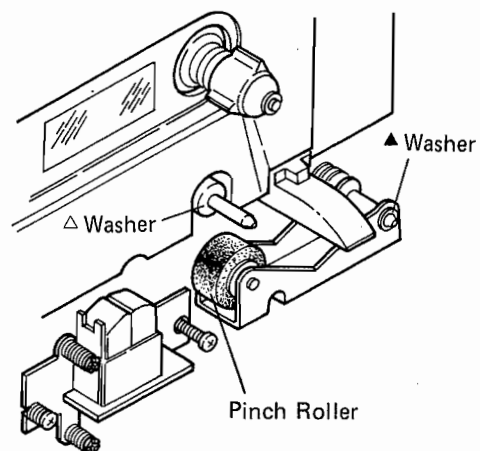
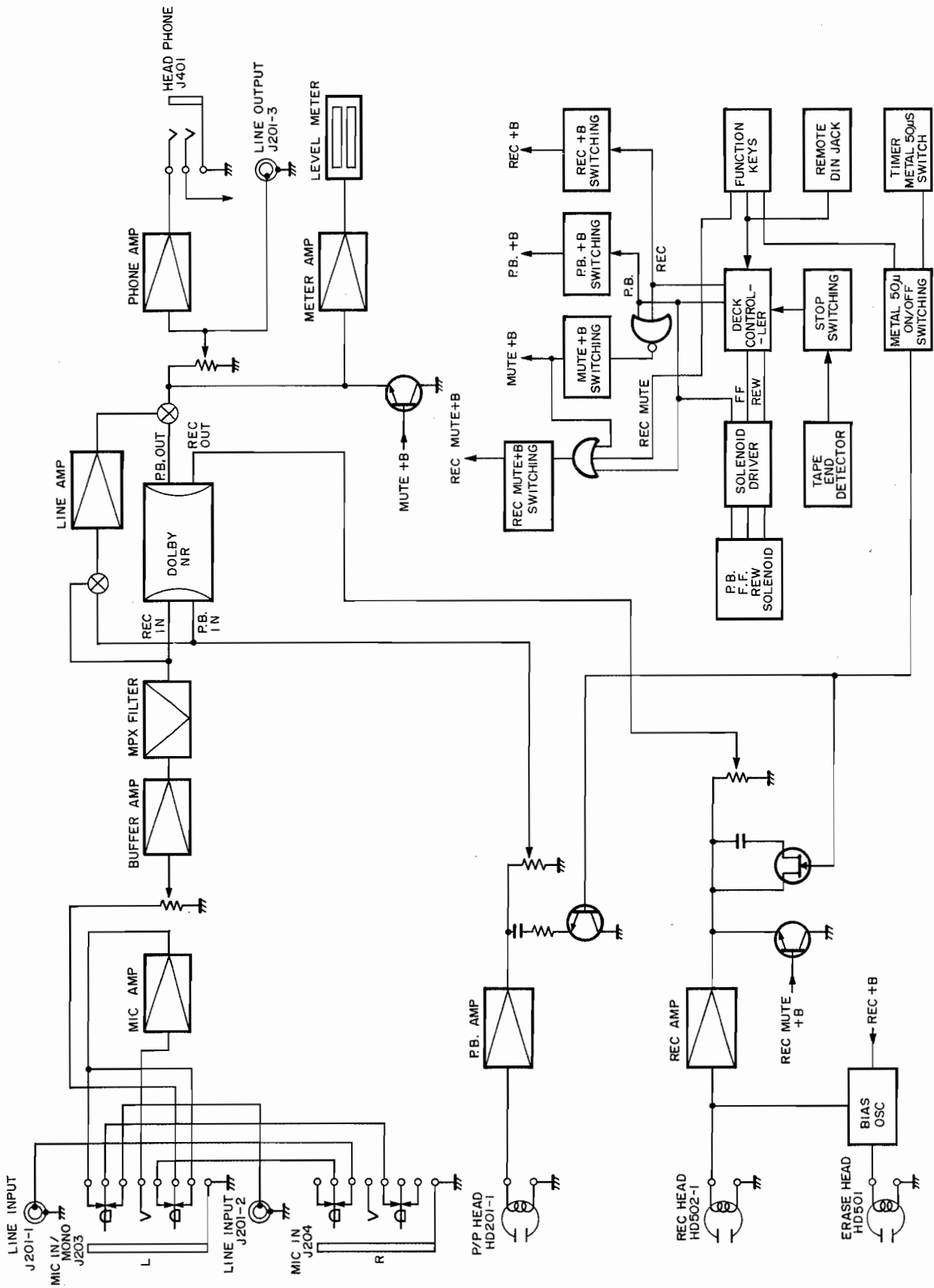

Figure 13

Block Diagram



Packing Assembly Parts List

Symbol No.	Part No.	Description
101	56B40230G23	Sack, Polyethylene
102	56C61295F01	Tray, Packing
103	56C58368F05	Carton, Packing
104	01V61200F41	Assembly, Pamphlet
104-1	※	Sack, Polyethylene
104-2	28T57397F01	Plug, Output
104-3	68P58585F64	Manual, Owners'
105	○ 30T60805F01	Cord, Set Semko
	■ 30T60804F01	Cord, Set UL/CSA
	△ 30T60974F01	Cord, Sets (SA)
106	■ 01V61900F89	Assembly, Warranty Card
106-1	■ 68P44370P57	Limited, Warranty
106-2	■ ※	Sack, Polyethylene

Symbol No.	Part No.	Description
Labels		
	54B42124G01	Serial No. (Rear Cover, Carton Packing)
	54B42124G01	Date Cord (Bottom Cover)
	54A57559F01	Side Caution (Side R of Top Cover)
	54A57559F02	Bottom Caution (Bottom Cover)
○	54B60770F02	Destination "G" (Carton Packing)
■	54B60770F01	Destination "C" (Carton Packing)
△	54B60770F04	Destination "R" (Carton Packing)
■	54A44553G01	CSA (Rear Cover)
■	54A62364F01	AC Inlet (Rear Cover)

NOTE: ※ The parts whose parts numbers are not entered will not be supplied.

○ : General Foreign model, ■ : North American model, △ : Australian model, Others: Common

Packing Method View

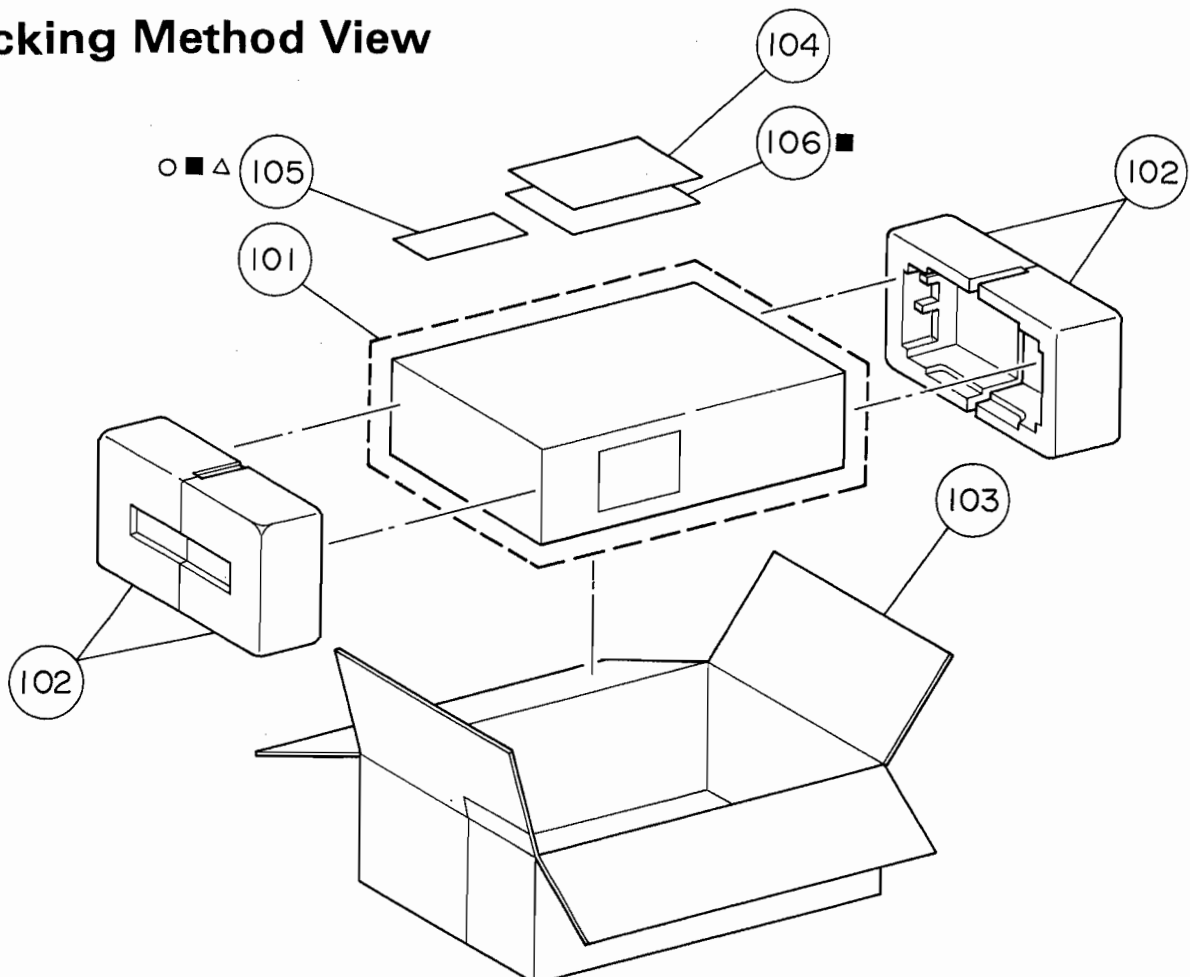

Adjustment Procedures

Step	Description	Mode	Adjust Points	Test Points	Connection Instruction	Remarks	
1	Tape Speed Adjustment	Playback Tape: Nor NR: Off	Round hole on the rear of the motor (Figure 15)	Line Out	Figure 16	Test Tape: MTT-111 (3 kHz) Adjust for 3000 ±30 Hz	
2	Head Height and Tilt Angle Adjustment	Turn the screw A and B to adjust the head height and tilt angle. (Figure 14) Use M-300 or AI-500 check bar to check the head height. The tip face of the check bar should stay parallel to the head surface to check the tilt angle. (See Note [1])					
3	Head Azimuth Adjustment	Playback Tape: Nor NR: Off	Head Azimuth Screw "C" (Figure 14)	Line Out	Figure 16	Turn the screw until the left and right signal levels become maximum and still more with the phase when reproducing MTT-114 (10 kHz) (It is necessary to readjust the head height as it moves if azimuth adjustment is too large)	
4	Playback Level Adjustment	Playback Tape: Nor NR: Off Monitor : Tape	VR201 VR202	T.P.3 T.P.4	Figure 17	Test Tape: MTT-150 Adjust for 580mV	
5	Input Adjustment	Rec/Pause Tape: Nor NR: Off Monitor : Source Bias: Off (See Note [1])	VR203	T.P.3 T.P.4	Figure 18	Test signal input: 400 Hz, 300mV Adjust for 580mV	
6	Monitor Level Adjustment	Rec/Pause Tape: Nor NR: Off Monitor : Source Bias: Off	VR403 VR404	T.P.5 T.P.6	Figure 18	Conditions at step 5 Adjust for 580mV	
7	Level Meter Adjustment	Rec/Pause Tape: Nor NR: Off Monitor : Source Bias: Off	VR801 VR802	Level Meter Reading	Figure 18	Conditions at step 6 Adjust for 0 dB (□□Mark)	
8	Rec. Current Adjustment	Rec/Play Tape : Metal NR: Off Bias: Off	VR501 VR502	T.P.1 T.P.2	Figure 18	Conditions at step 7 Adjust for 1.3mV See chart below for another typical bias level.	
						Bias	Level
						CrO ₂	1.3mV
						NORM	1mV

Step	Description	Mode	Adjust Points	Test Points	Connection Instruction	Remarks
9	Record/Play Bias Adjustment	1 Rec/Play Tape : Metal NR: Off	VR505 VR506	T.P.1 T.P.2	Figure 18	Test Signal Input: 400 Hz, 300mV Adjust for 14mV
		2 Rec/Play Tape : CrO ₂ NR: Off	VR503 VR504	T.P.1 T.P.2	Figure 18	Adjust for 8mV (14mV - 4.5 dB)
		3 Rec/Play Tape : Nor NR: Off	VR508	T.P.1 T.P.2	Figure 18	Adjust for 6mV (14mV - 7.5 dB)

Note [I]: Bias Off
T.P.9 to ground.

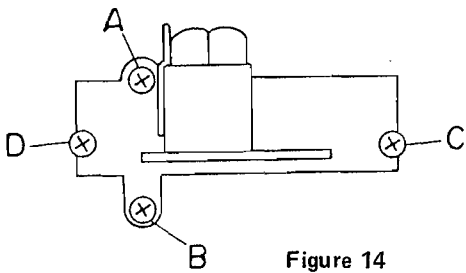

Figure 14

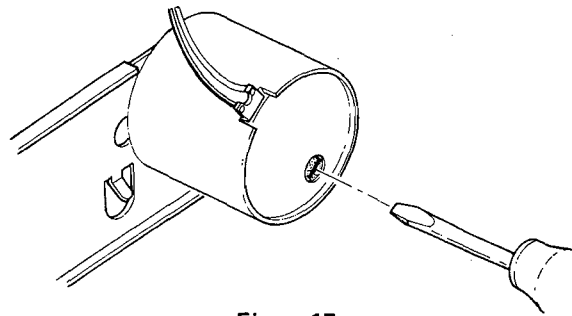

Figure 15

● Connection Diagram

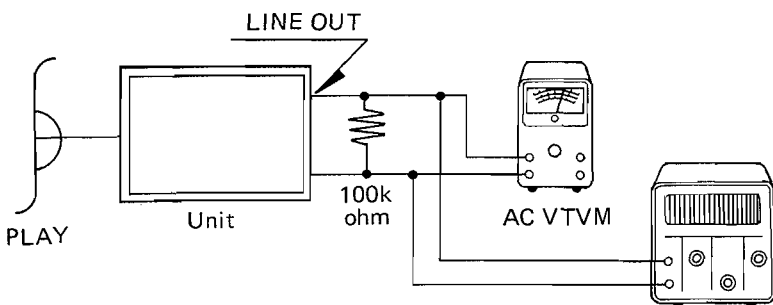

Figure 16

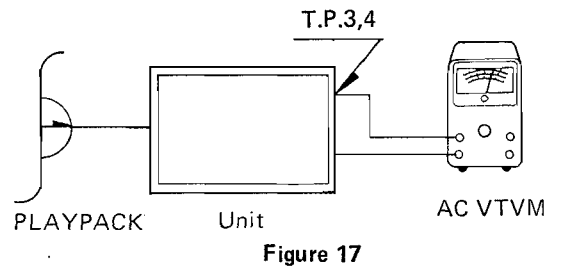

Figure 17

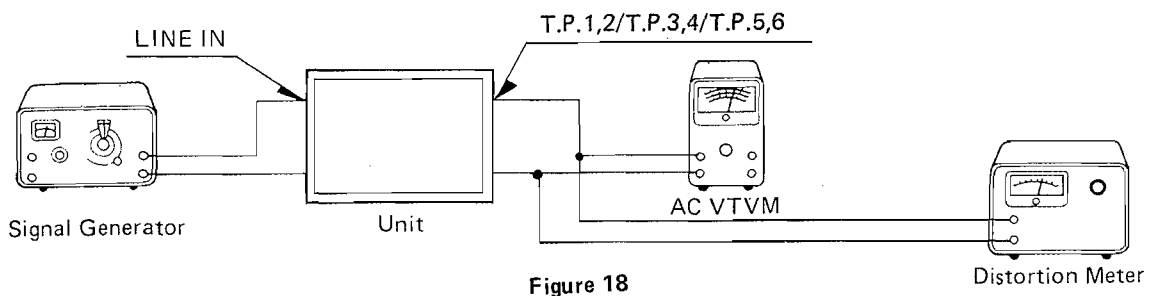

Figure 18

Note [II]**Initial Setup**

1. Place the gauge plate in a tape transport just as a cassette tape is normally inserted. (Some transports may require cover removal to make easy access to the head and guide area.)
2. Firmly seat the gauge plate on the horizontal locating-surface. The gauge plate has been machined flat to within ± 0.051 millimeters; therefore, it will indicate any height errors to the locating surfaces. The gauge plate should not rock if the transports cassette locating surfaces are properly adjusted.
3. Bring the heads into the normal play/record position before taking any measurements as detailed in the procedures to follow.

Tape Guide Measurement (Figure 19)

Place the guide-check bar on its side on the top surface to the gauge plate and slide the bar up to the record head's tape guide fingers. The bar will exactly slide into these fingers if they are at the proper height. This will indicate the guide height with respect to the top gauge plate surface. This height is chosen as the nominal lower tape edge position with respect to the Phillips standards. If the guides are high or low, adjust the head and/or adjust the tape guide to the indicated height.

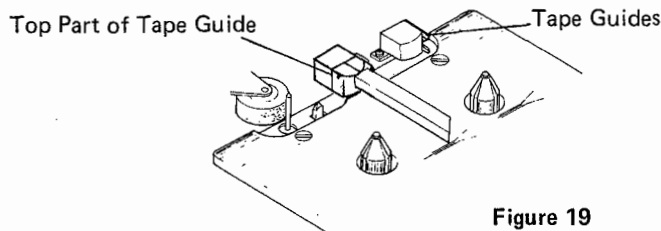

Figure 19

Head Perpendicularity Measurement (Figure 20 and 21)

1. Position the square end of the guide-check bar against the head surface at its apex.
2. Observe the tilt of the head by using a flashlight to back-illuminate the head-to-bar interface. When the head is properly adjusted, no light will show.
3. If required, place shims under the head fixture on the transport to eliminate tilt. An offset dental mirror is useful for checking head tilt.

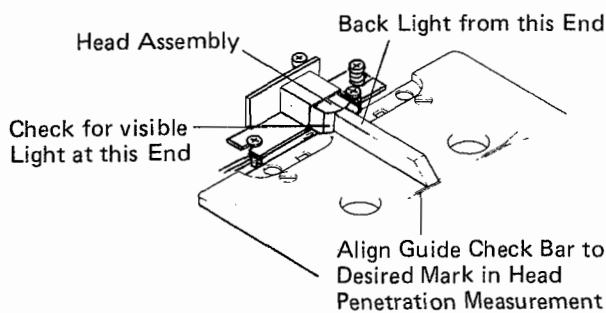

Figure 20

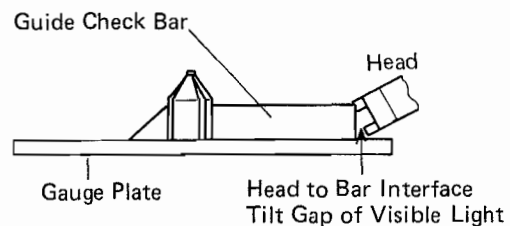

Figure 21

Head Penetration Measurement

Head perpendicularity must be checked before making this measurement. Refer to Figures 20 & 21 for head perpendicularity measurement during this procedure.

Head Penetration Measurement

Head perpendicularity must be checked before making this measurement. Refer to Figures 20 & 21 for head perpendicularity measurement during this procedure.

1. Place the guide-check bar squarely against the head apex with the knife-edge firmly held against the reference etch marks.
2. Verify that the knife edge lies within the MAX, O, MIN reference etch marks.
2. Adjust the head position if the knife-edge is not in the indicated range.
4. Ensure that the bar is perpendicular to the head when taking this measurement.

<NOTE: M-300 gauge is supplied from ALPINE. Refer to International Marketing Department if necessary.>

Adjustment Locations

● Master P.C. Board

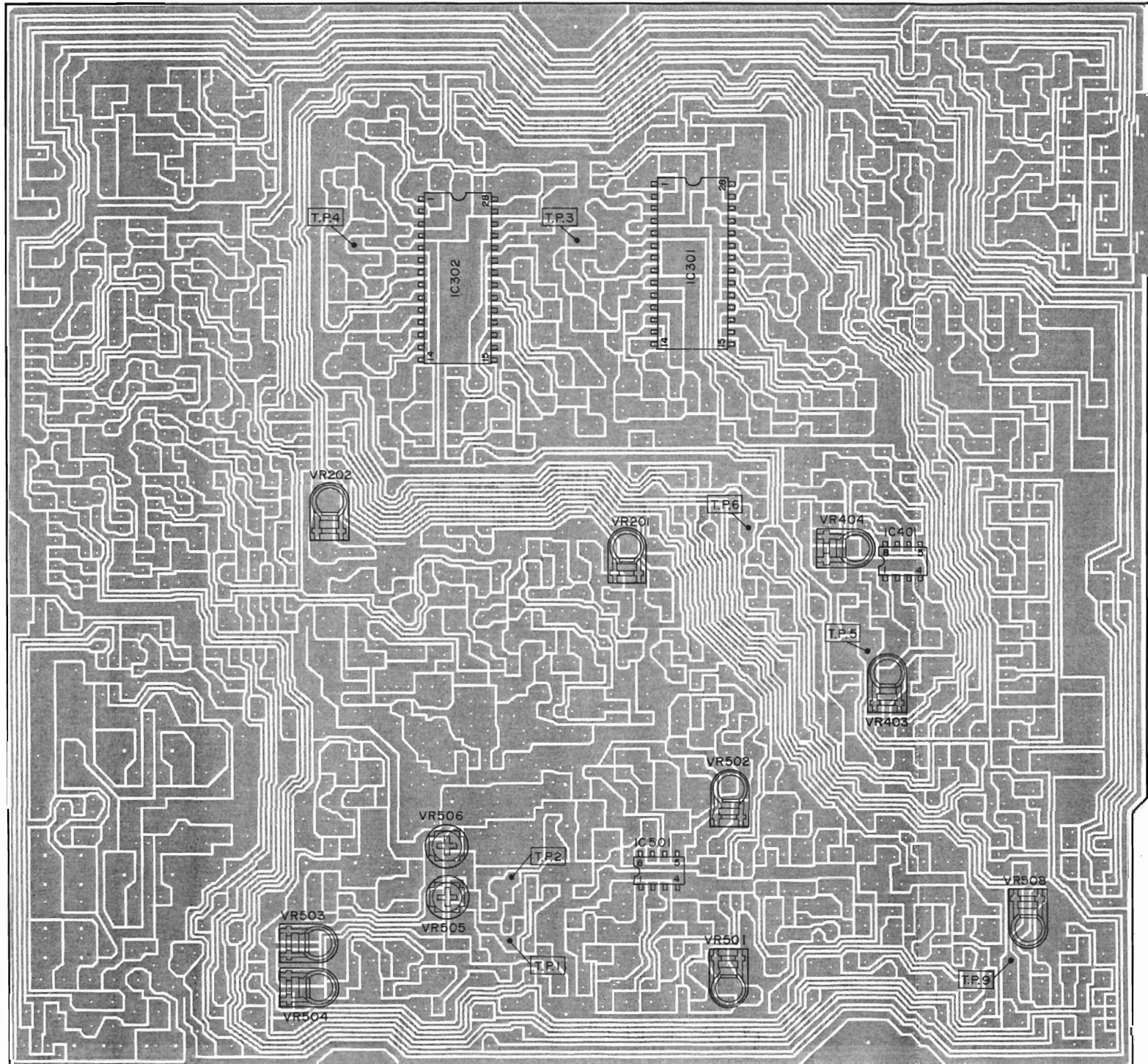

● Meter P.C. Board

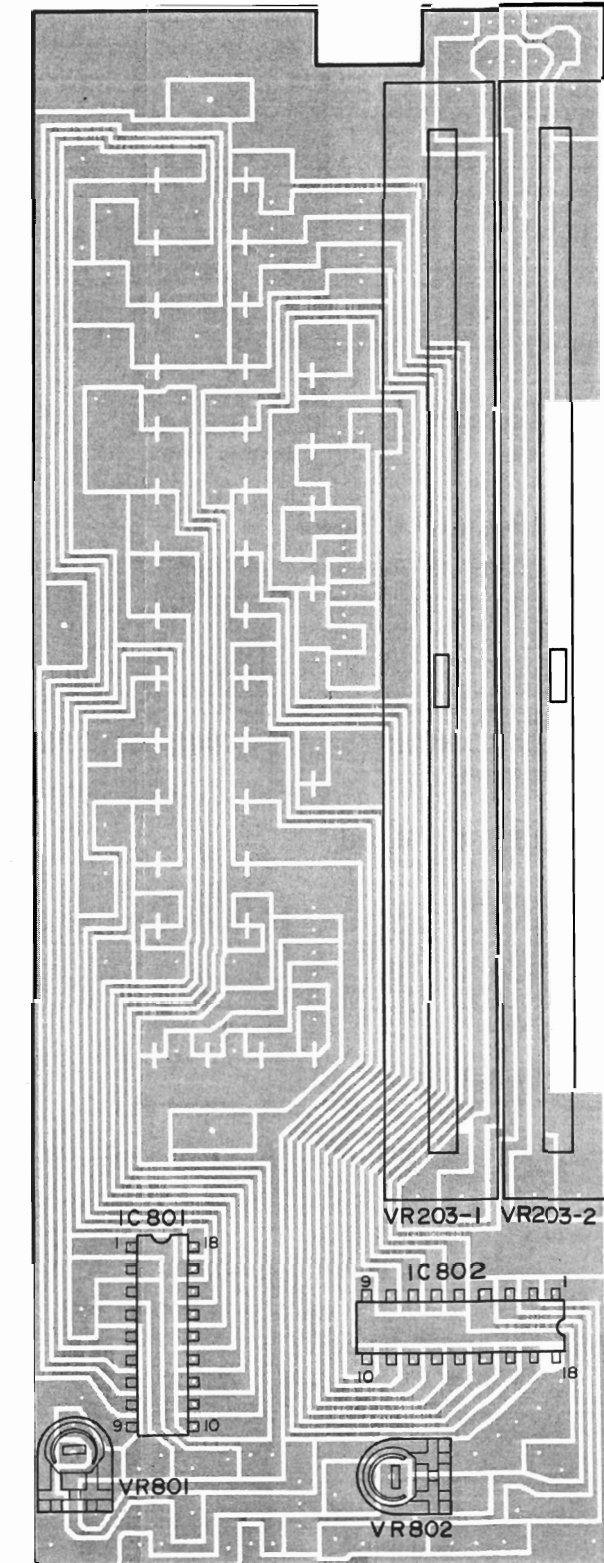

Parts Layout on P.C. Boards

• Power P.C. Board

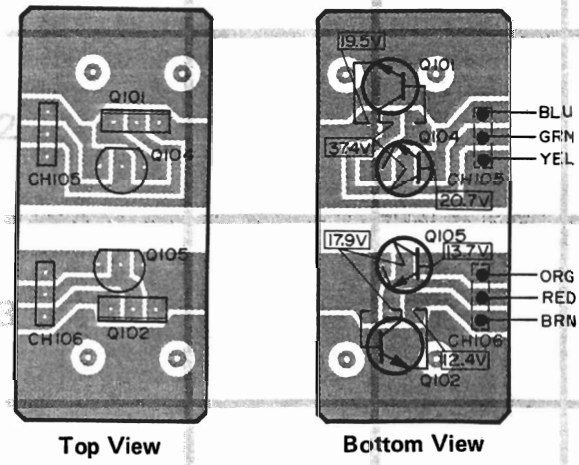

• Master P.C. Board

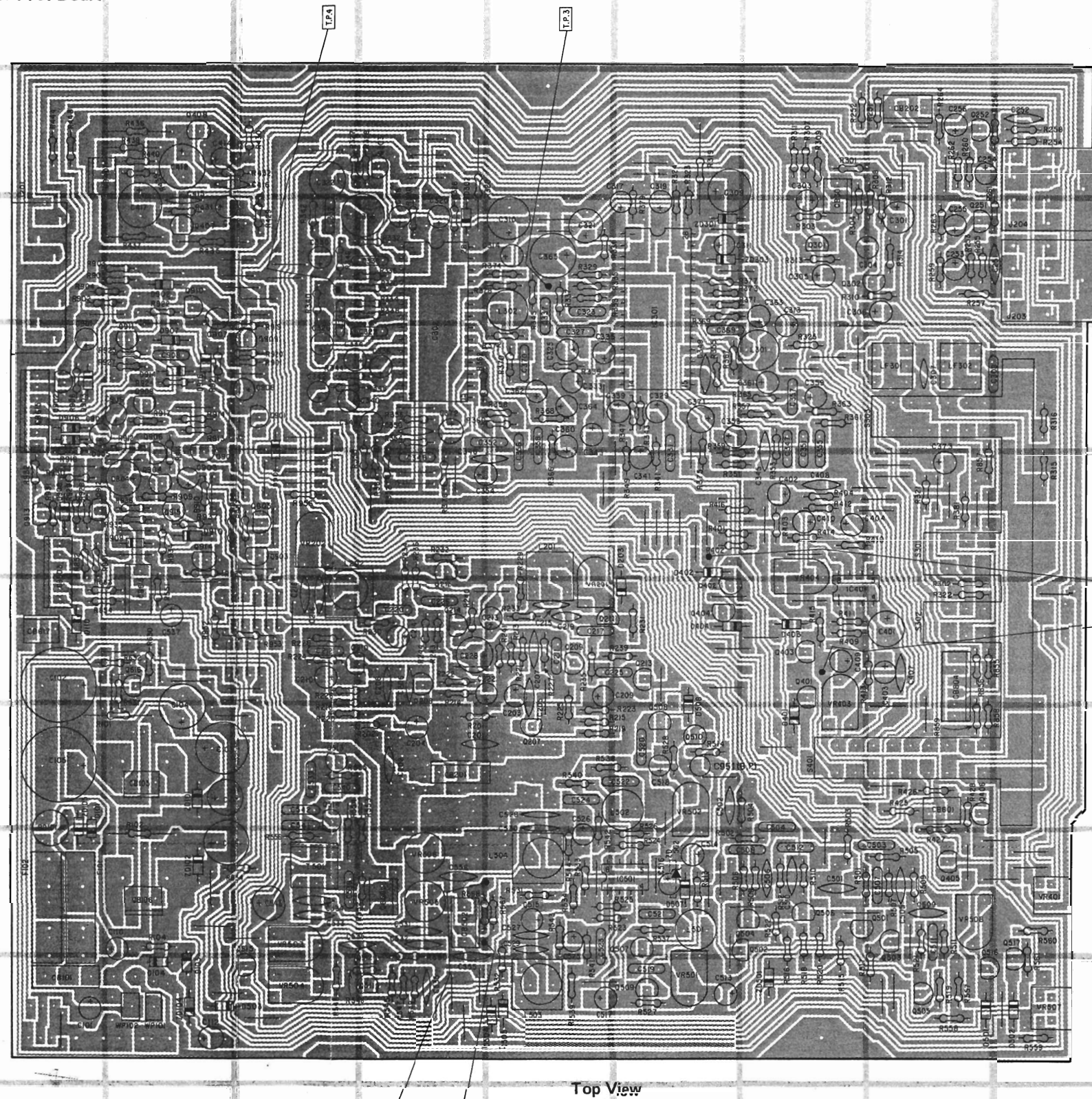

• Timer Switch P.C. Board

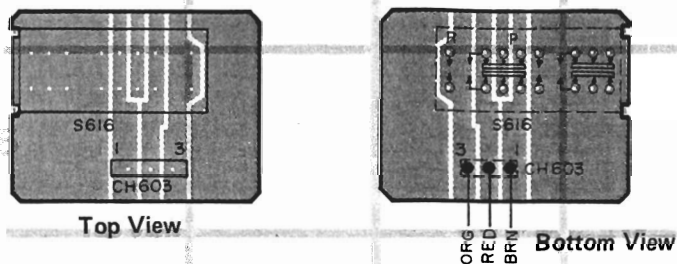

• REC LED P.C. Board

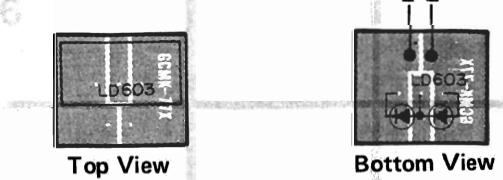

• Reed Switch P.C. Board

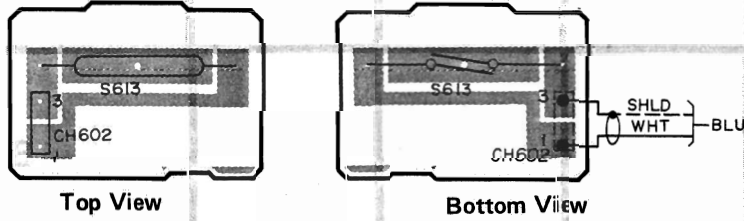

• Headphone P.C. Board

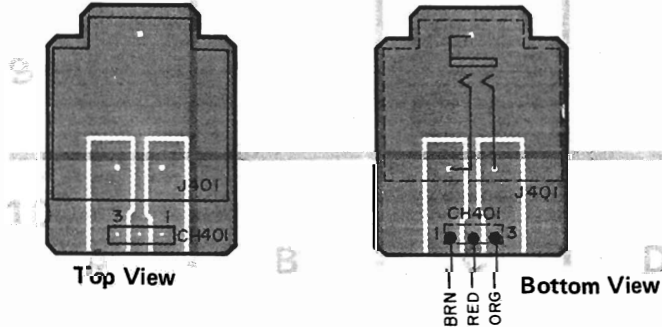

● Master P.C. Board

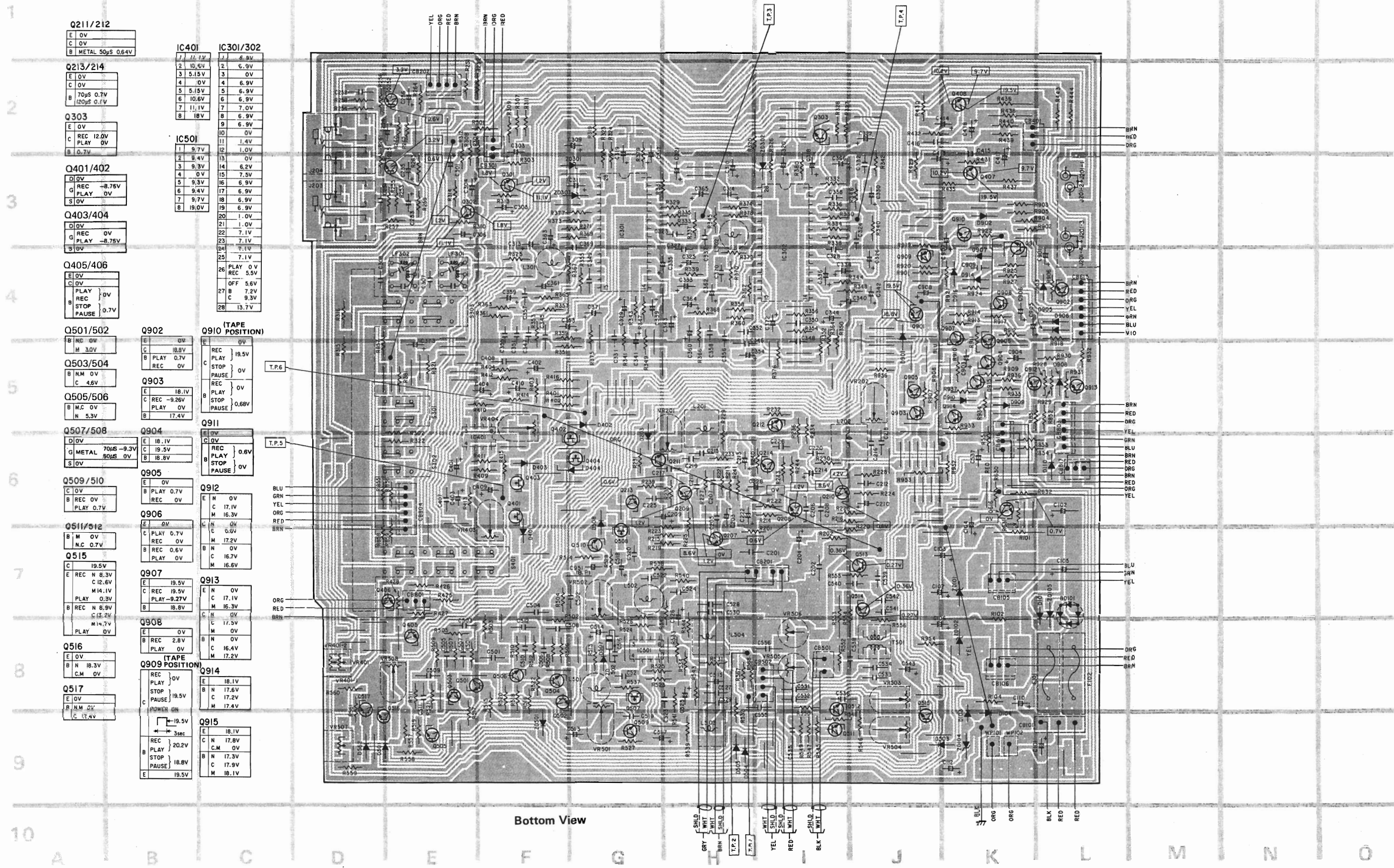

Q211/212	
E	0V
C	0V
B	METAL 50pS 0.64V

Q213/214	
E	0V
C	0V
B	70pS 0.7V
B	120pS 0.1V

Q303	
E	0V
C	REC 12.0V
B	PLAY 0V

Q401/402	
D	0V
G	REC -8.75V
S	PLAY 0V

Q403/404	
D	0V
G	REC 0V
S	PLAY -8.75V

Q405/406	
E	0V
C	0V
B	PLAY 0V
B	REC STOP PAUSE 0.7V

Q501/502	
B	M.C 0V
M	3.0V

Q503/504	
B	M.C 0V
C	4.6V

Q505/506	
B	M.C 0V
N	5.3V

Q507/508	
D	0V
G	METAL 70pS -9.3V
S	50pS 0V

Q509/510	
C	0V
B	REC 0V
B	PLAY 0.7V

Q511/512	
B	M 0V
M	C 0.7V
B	N.C 0.7V

Q515	
C	19.5V
E	REC N 8.3V
C	12.6V
M	14.1V
PLAY	0.3V
B	REC N 8.9V
C	13.2V
M	14.7V
PLAY	0V

Q516	
E	0V
B	N 18.3V
C	M 0V

Q517	
E	0V
B	N.M 0V
C	17.4V

IC401	
1	11.1V
2	10.0V
3	5.15V
4	0V
5	5.15V
6	10.6V
7	11.1V
8	18V

IC301/302	
1	6.9V
2	6.9V
3	0V
4	6.9V
5	6.9V
6	6.9V
7	7.0V
8	6.9V
9	6.9V
10	0V
11	1.4V
12	1.0V

IC501	
1	9.7V
2	8.4V
3	9.3V
4	0V
5	9.3V
6	9.4V
7	9.7V
8	19.0V
19	6.9V
20	1.0V
21	1.0V
22	7.1V
23	7.1V
24	7.1V
25	7.1V
26	PLAY 0V
REC	5.5V
OFF	5.6V
27	7.2V
C	9.3V
28	13.7V

Q902	
B	M.C 0V
C	18.8V
C	PLAY 0.7V
REC	0V

Q903	
E	18.1V
C	REC -9.26V
B	M.C 0V
N	5.3V

Q904	
E	18.1V
C	19.5V
B	18.8V

Q905	
E	0V
B	PLAY 0.7V
REC	0V

Q906	
E	0V
C	PLAY 0.7V
REC	0V
B	REC 0.6V
PLAY	0V

Q907	
E	19.5V
C	REC 19.5V
PLAY	-9.27V
B	18.8V

Q908	
E	0V
B	REC 2.8V
PLAY	0V

Q909 POSITION	
REC	0V
PLAY	0V
STOP	19.5V
PAUSE	19.5V
C	POWER ON
E	19.5V
B	3sec
REC	20.2V
PLAY	0V
STOP	18.8V
PAUSE	19.5V

Q914	
E	18.1V
B	N 17.6V
C	M 17.2V
M	17.4V

Q915	
E	18.1V
C	N 17.8V
C.M	0V
B	N 17.3V
C	M 17.9V
M	18.1V

Bottom View

● Control P.C. Board

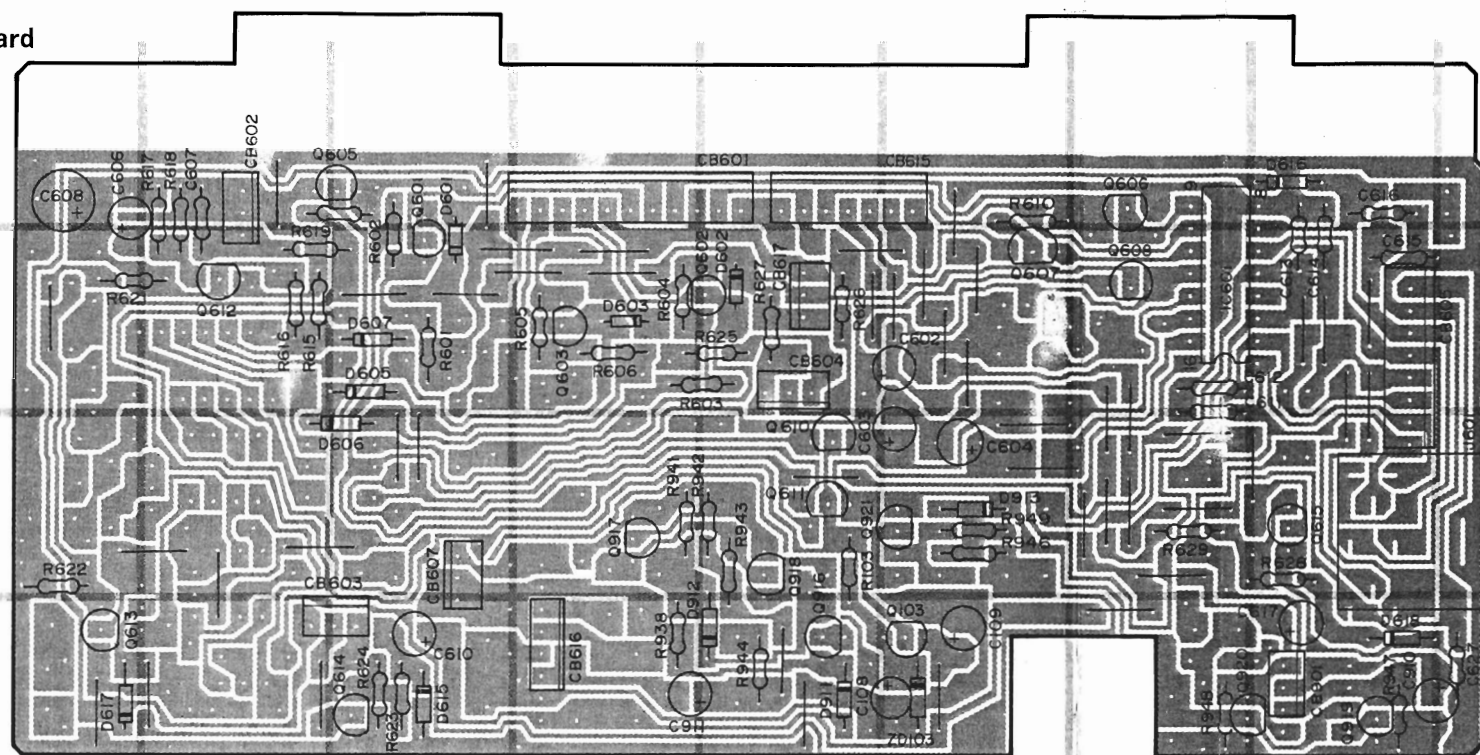

Top View

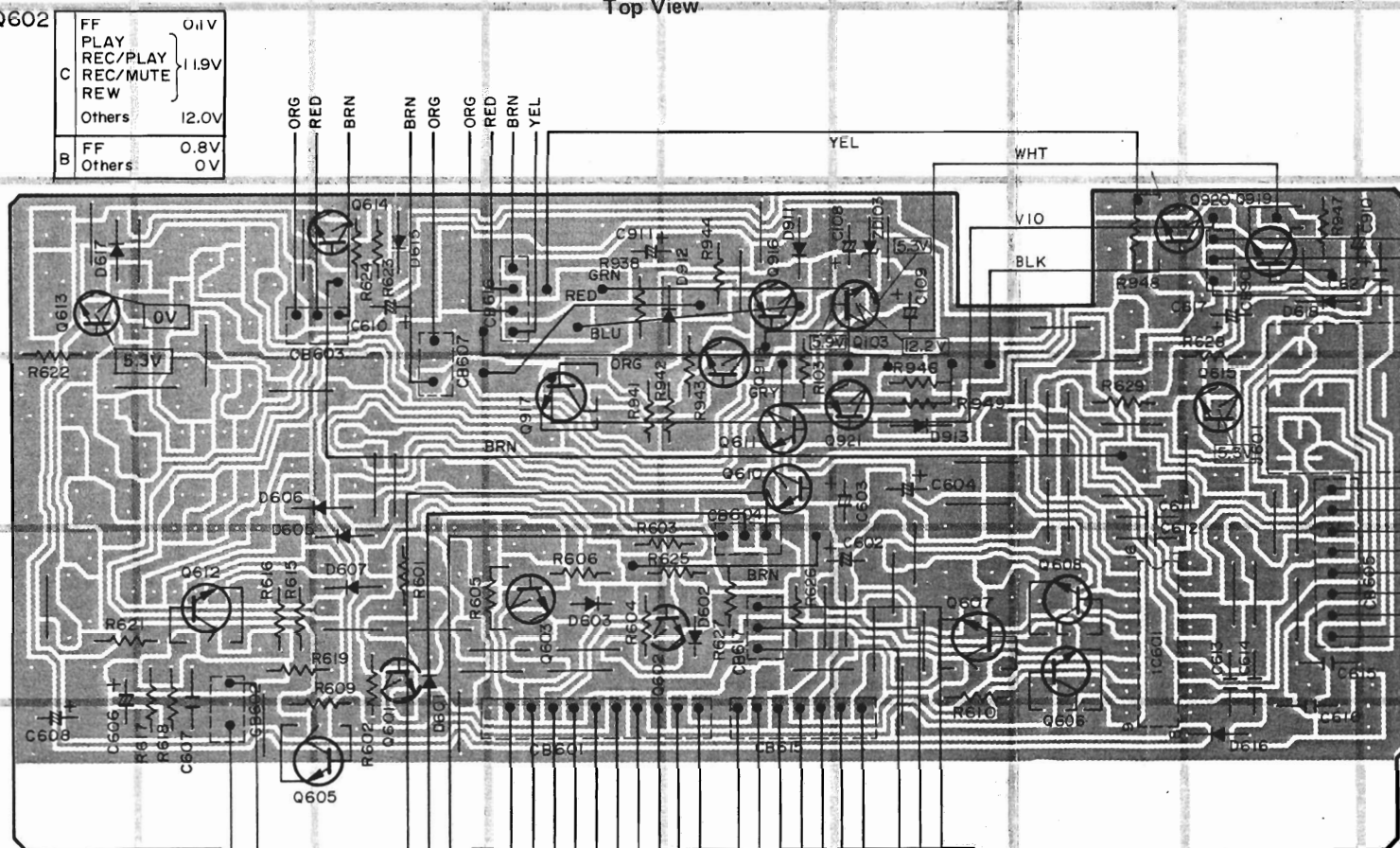

Bottom View

Q603

REW	0.1V
PLAY	0.1V
REC/PLAY	11.9V
REC/MUTE	11.9V
Others	12.0V
REW	0.8V
Others	0V

Q602

FF	0.1V
PLAY	0.1V
REC/PLAY	11.9V
REC/MUTE	11.9V
REW	11.9V
Others	12.0V
FF	0.8V
Others	0V

Q601

PLAY	0.1V
REC/PLAY	0.1V
REC/MUTE	0.1V
FF/REW	11.9V
Others	12.0V
PLAY	0.8V
REC/PLAY	0.8V
REC/MUTE	0.8V
Others	0V

Q614

POWER ON	0V
POWER ON	5.1V
POWER ON	8sec
POWER ON	0.7V
POWER ON	0V

Q917(B) Q918(C)

M170_M150_M170	0.74V
SW PUSW	1.4V
SW PUSW	0.74V

Q612

PAUSE	0V
STOP	0V
Others	0V

Q610

REW	4.5V
Others	0V

Q611

FF	4.5V
Others	0V

Q605, 606

PACK IN	0V
PACK OUT	0.7V
PACK IN	5.3V
PACK OUT	0V

Q607

PAUSE	4.5V
Others	0V
STOP	5.2V
Others	0.1V

Q916

METAL	70µs -9.6V
50µs	17.26V
METAL	70µs 17.3V
50µs	0.02V

Q919

METAL	70µs 0.33V
50µs	0.7V

Q920

METAL	70µs 0.7V
50µs	0.33V

Q608

PLAY	4.1V
REC/PLAY	4.1V
REC/MUTE	4.1V
Others	0V
PLAY	4.9V
REC/PLAY	4.9V
REC/MUTE	4.8V
FF/REW	0.1V
Others	0V

IC 601

1	5.3V
2	5.3V
3	5.3V
4	5.3V
5	5.3V
6	5.3V
7	5.3V
8	0V
9	PACK IN 5.3V
10	PACK OUT 0V
11	PLAY, FF / REW
12	0.1V
13	REC
14	4.8V
15	Others
16	0V

Q921

METAL	70µs 0.02V
50µs	17.3V
METAL	70µs 17.3V
50µs	0.02V

● Keyboard P.C. Board

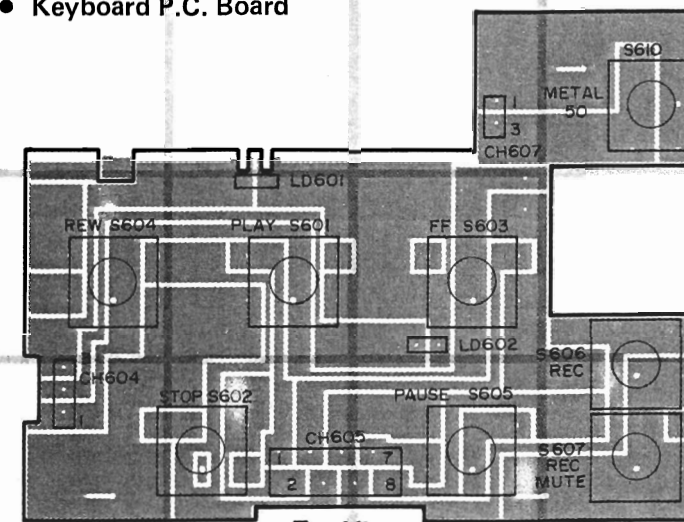

Top View

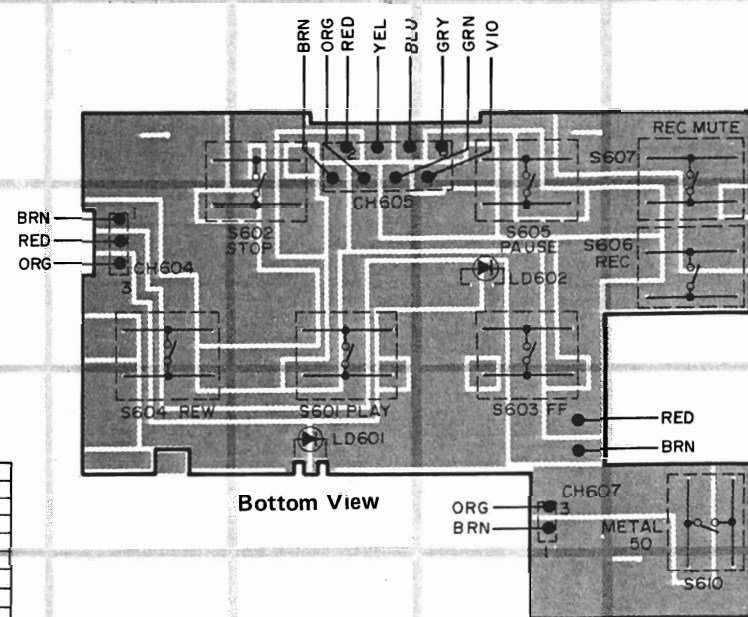

Bottom View

● Head P.C. Board

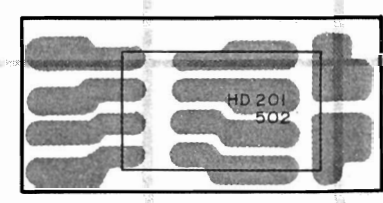

Top View

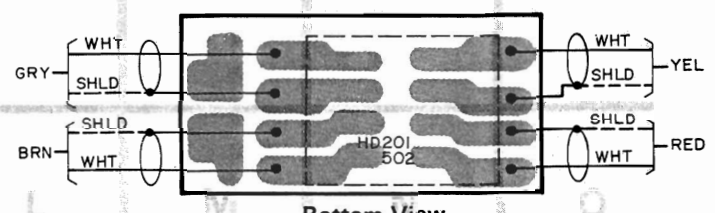

Bottom View

• Meter P.C. Board

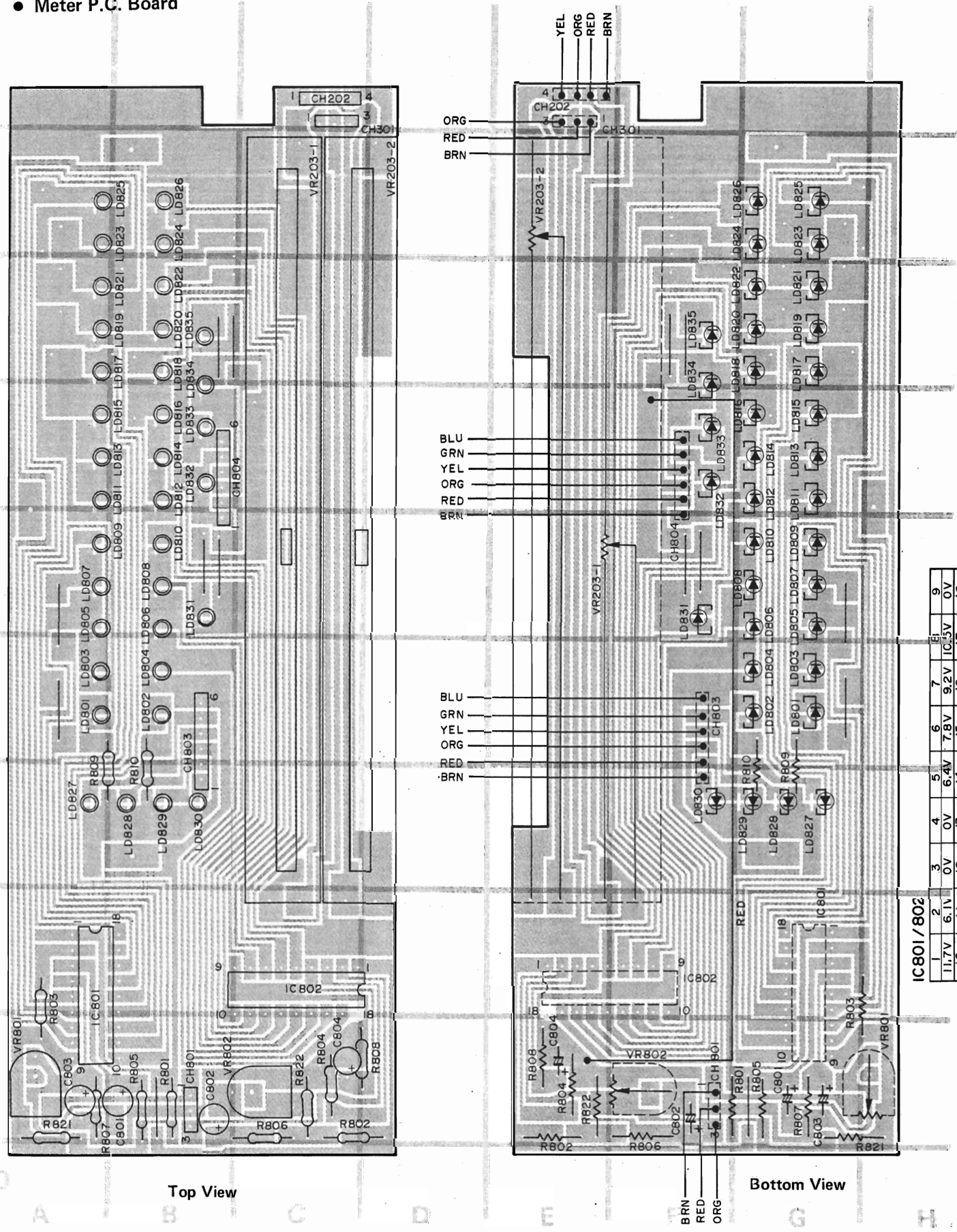

Wiring Diagram

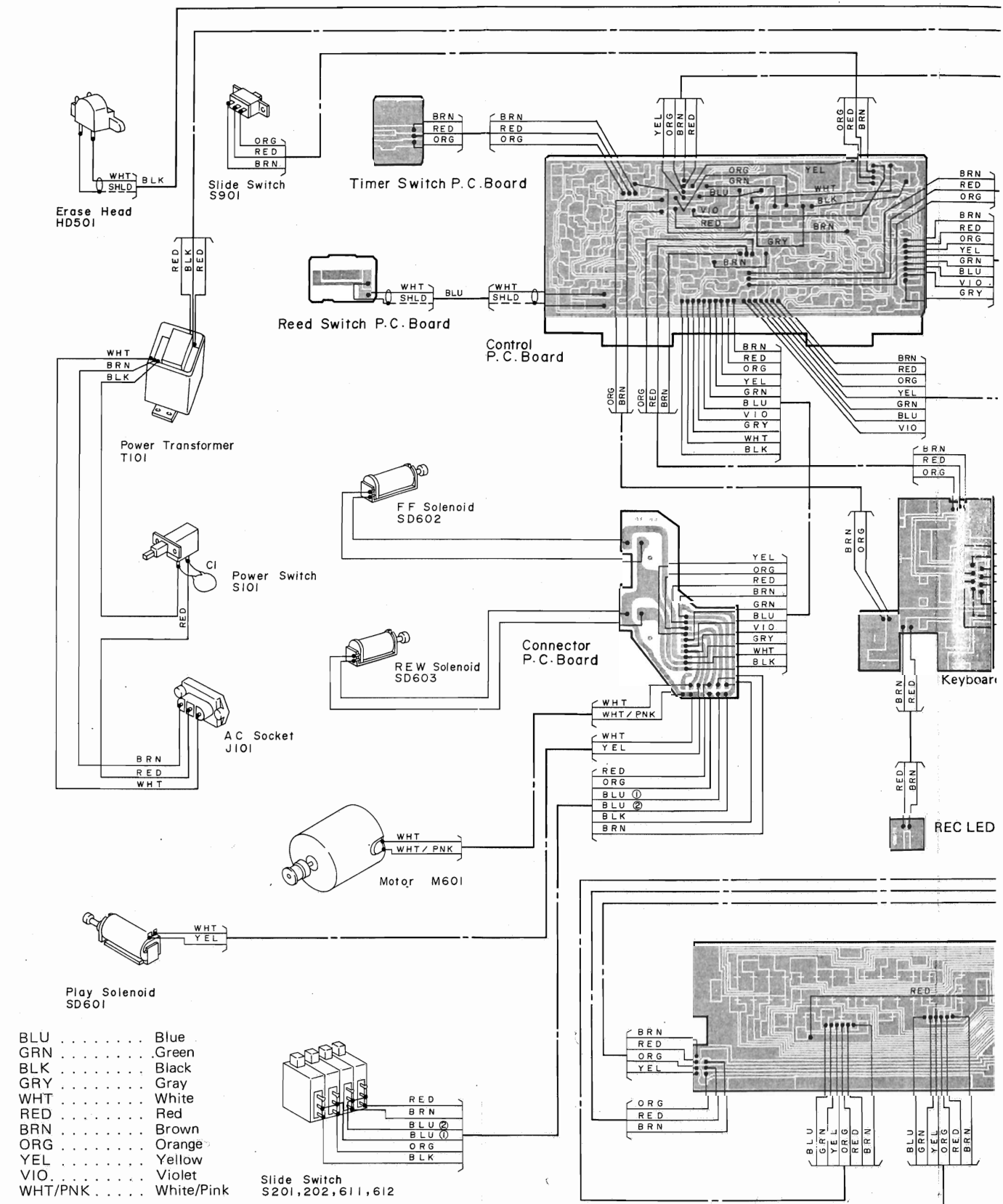

Wiring Diagram

IC801/802

1	11.7V	6.2V
2	6.1V	7.5V
3	0V	9.0V
4	0V	10.4V
5	6.4V	6.3V
6	7.8V	7.5V
7	9.2V	9.0V
8	0V	10.4V
9	0V	0V
10	0V	0V
11	0V	0V
12	0V	0V
13	0V	0V
14	0V	0V
15	0V	0V
16	0V	0V
17	0V	0V
18	0V	0V

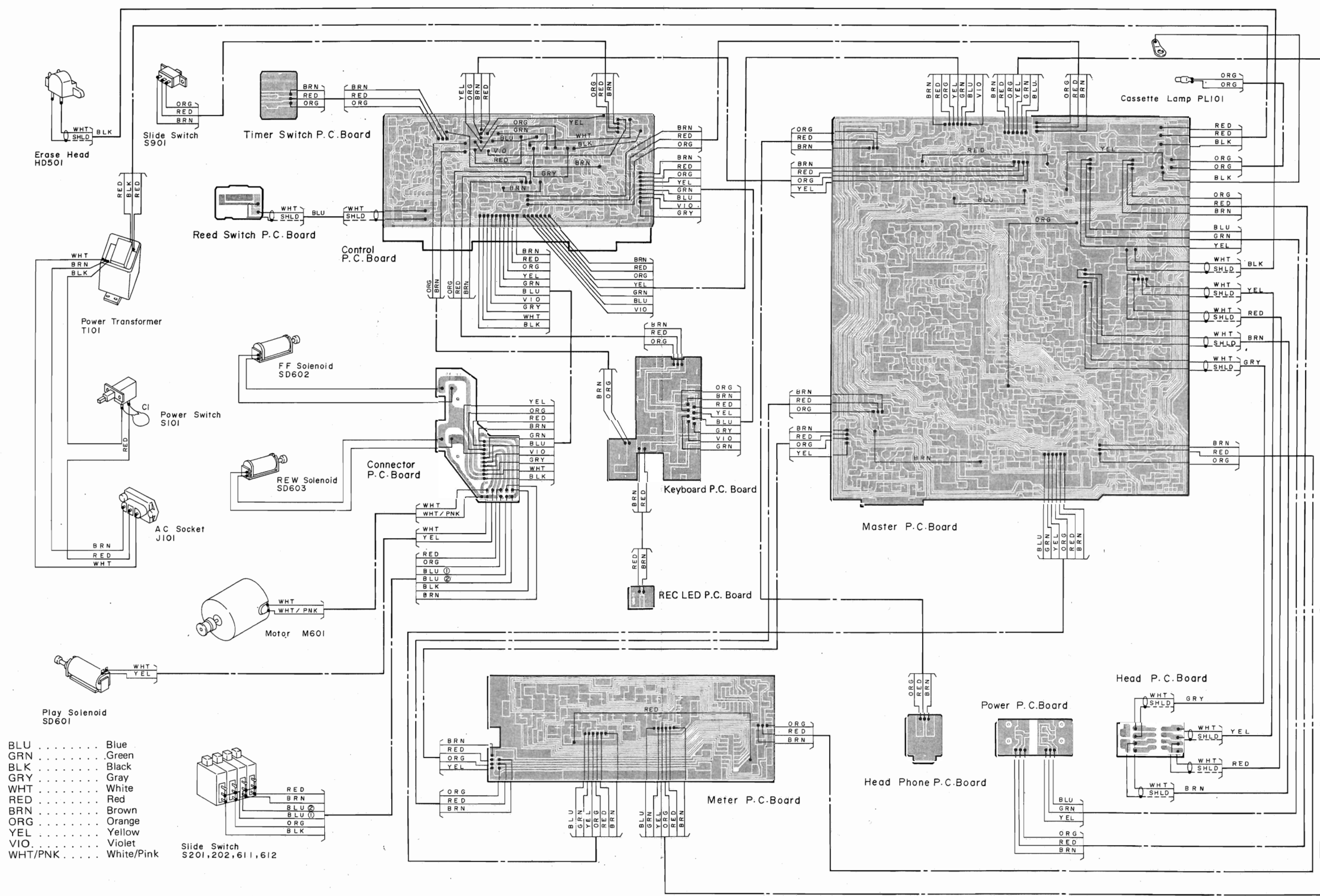

Schematic Diagram

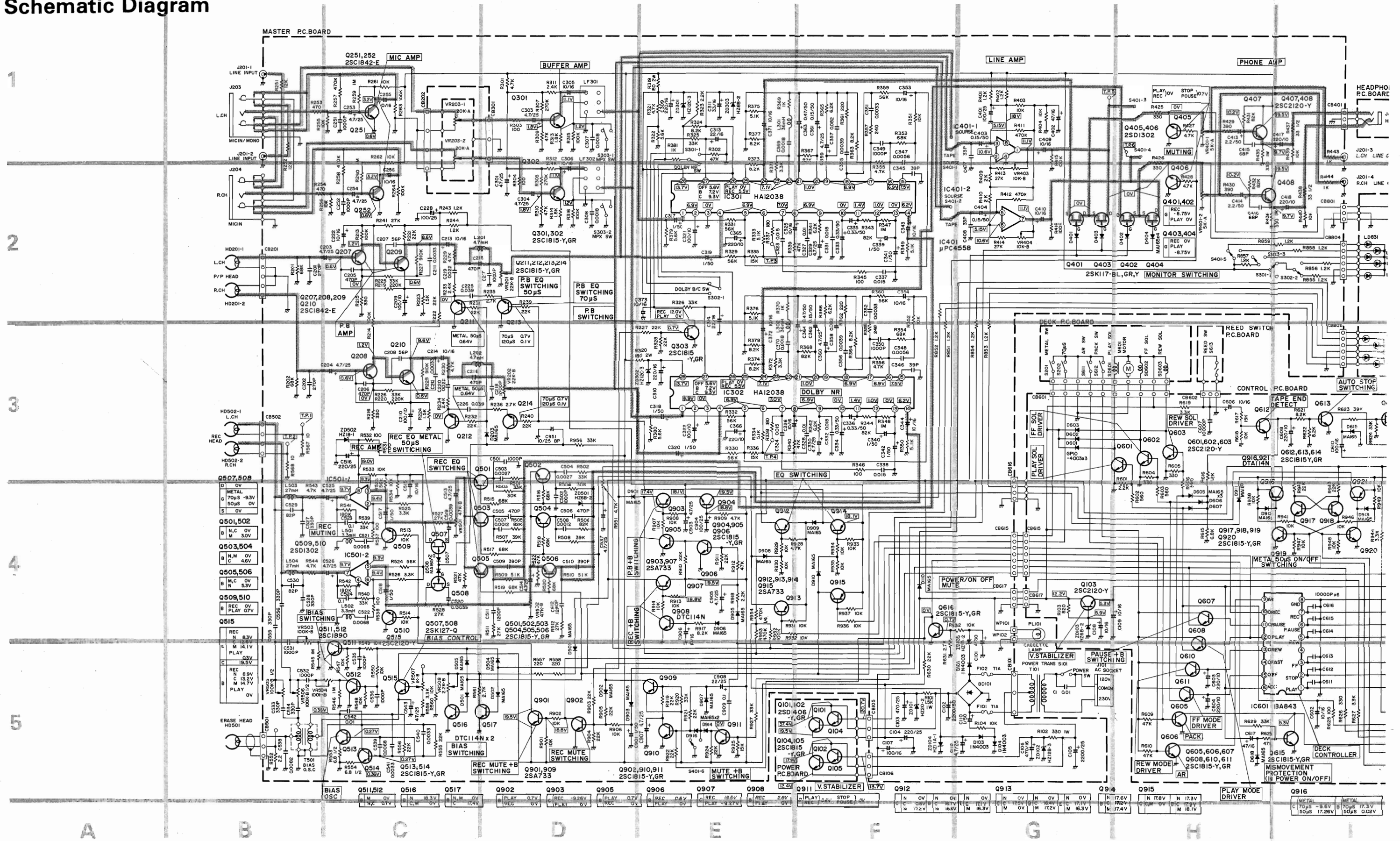

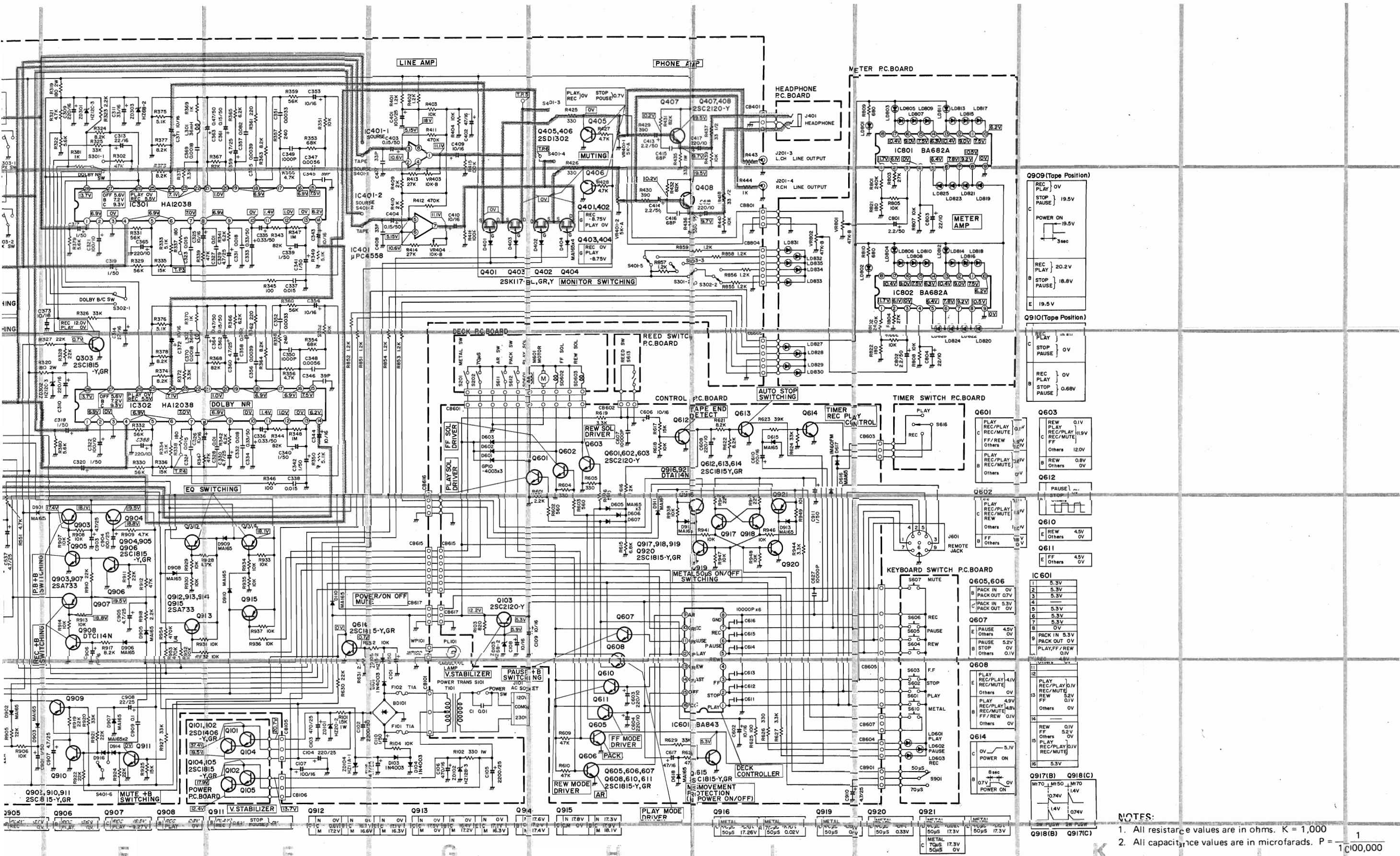

NOTES:
 1. All resistor values are in ohms. K = 1,000
 2. All capacitance values are in microfarads. P = 1/100,000

Electrical Parts List

Resistors (All resistors are carbon film, 1/6W, $\pm 5\%$ unless otherwise noted.)
 uF = microfarads, pF = picofarads

Symbol No.	Part No.	Description
Master P.C. Board		
IC's		
IC301	51T52160F01	HA12038-01
IC302	51T52160F01	HA12038-01
IC401	51S43471U02	μ PC4558C
IC501	51S43471U02	μ PC4558C
Transistors		
Q207	48S47706F04	2SC1843E
or	48S47708F04	2SC1842E
Q208	48S47706F04	2SC1843E
or	48S47708F04	2SC1842E
Q209	48S47706F04	2SC1843E
or	48S47708F04	2SC1842E
Q210	48S47706F04	2SC1843E
or	48S47708F04	2SC1842E
Q211	48S43525F05	2SC1815-Y, GR
or	48S44578J01	2SC945L-P
Q212	48S43525F05	2SC1815-Y, GR
or	48S44578J01	2SC945L-P
Q213	48S43525F05	2SC1815-Y, GR
or	48S44578J01	2SC945L-P
Q214	48S43525F05	2SC1815-Y, GR
or	48S44578J01	2SC945L-P
Q251	48S47706F04	2SC1843E
or	48S47708F04	2SC1842E
Q252	48S47706F04	2SC1843E
or	48S47708F04	2SC1842E
Q301	48S43525F05	2SC1815-Y, GR
or	48S44578J01	2SC945L-P
Q302	48S43525F05	2SC1815-Y, GR
or	48S44578J01	2SC945L-P
Q303	48S43525F05	2SC1815-Y, GR
or	48S44578J01	2SC945L-P
Q401	48S47729F02	FET, 2SK117BL
or	48S47729F01	FET, 2SK117GR
or	48T51539F01	FET, 2SK117(Y)
or	48S42538U01	FET, 2SK127Q
or	48S42538U02	FET, 2SK127R
or	48S42539U01	FET, 2SK128Q
or	48S42539U02	FET, 2SK128R

Symbol No.	Part No.	Description
Q402	48S47729F02	FET, 2SK117BL
or	48S47729F01	FET, 2SK117GR
or	48T51539F01	FET, 2SK117(Y)
or	48S42538U01	FET, 2SK127Q
or	48S42538U02	FET, 2SK127R
or	48S42539U01	FET, 2SK128Q
or	48S42539U02	FET, 2SK128R
Q403	48S47729F02	FET, 2SK117BL
or	48S47729F01	FET, 2SK117GR
or	48T51539F01	FET, 2SK117(Y)
or	48S42538U01	FET, 2SK127Q
or	48S42538U02	FET, 2SK127R
or	48S42539U01	FET, 2SK128Q
or	48S42539U02	FET, 2SK128R
Q404	48S47729F02	FET, 2SK117BL
or	48S47729F01	FET, 2SK117GR
or	48T51539F01	FET, 2SK117(Y)
or	48S42538U01	FET, 2SK127Q
or	48S42538U02	FET, 2SK127R
or	48S42539U01	FET, 2SK128Q
or	48S42539U02	FET, 2SK128R
Q405	48T57305F01	2SD1302-S, T
Q406	48T57305F01	2SD1302-S, T
Q407	48T43015U01	2SC2120-Y
or	48S40832F03	2SC1318NC-R
Q408	48T43015U01	2SC2120-Y
or	48S40832F03	2SC1318NC-R
Q501	48S43525F05	2SC1815-Y, GR
or	48S44578J01	2SC945L-P
Q502	48S43525F05	2SC1815-Y, GR
or	48S44578J01	2SC945L-P
Q503	48S43525F05	2SC1815-Y, GR
or	48S44578J01	2SC945L-P
Q504	48S43525F05	2SC1815-Y, GR
or	48S44578J01	2SC945L-P
Q505	48S43525F05	2SC1815-Y, GR
or	48S44578J01	2SC945L-P
Q506	48S43525F05	2SC1815-Y, GR
or	48S44578J01	2SC945L-P
Q507	48S42538U01	FET, 2SK127Q
or	48S42539U01	FET, 2SK128Q
or	48T52122F01	FET, 2SK301R
or	48T52122F02	FET, 2SK301Q
or	48S42539U02	FET, 2SK128R
or	48S42538U02	FET, 2SK127R

Symbol No.	Part No.	Description
Q508	48S42539U01	FET, 2SK128Q
or	48T52122F01	FET, 2SK301R
or	48T52122F02	FET, 2SK301Q
or	48S42539U02	FET, 2SK128R
or	48S42538U01	FET, 2SK127Q
or	48S42583U02	FET, 2SK127R
Q509	48T57305F01	2SD1302-S, T
Q510	48T57305F01	2SD1302-S, T
Q511	48S41196U03	2SC1980-T
or	48S43394P01	2SC1890E, F
Q512	48S41196U03	2SC1980-T
or	48S43394P01	2SC1890E, F
Q513	48S43525F05	2SC1815-Y, GR
or	48S44578J01	2SC945L-P
Q514	48S43525F05	2SC1815-Y, GR
or	48S44578J01	2SC945L-P
Q515	48T43015U01	2SC2120-Y
or	48S40832F03	2SC1318NC-R
Q516	48T61307F01	DTC114
Q517	48T61307F01	DTC114
Q616	48S43525F05	2SC1815-Y, GR
or	48S44578J01	2SC945L-P
Q901	48T40081T03	2SA733 (P)
Q902	48S43525F05	2SC1815-Y, GR
or	48S44578J01	2SC945L-P
Q903	48T40081T03	2SA733 (P)
Q904	48S43525F05	2SC1815-Y, GR
or	48S44578J01	2SC945L-P
Q905	48S43525F05	2SC1815-Y, GR
or	48S44578J01	2SC945L-P
Q906	48S43525F05	2SC1815-Y, GR
or	48S44578J01	2SC945L-P
Q907	48T40081T03	2SA733 (P)
Q908	48T61307F01	DTC114
Q909	48T40081T03	2SA733 (P)
Q910	48S43525F05	2SC1815-Y, GR
or	48S44578J01	2SC945L-P
Q911	48S43525F05	2SC1815-Y, GR
or	48S44578J01	2SC945L-P
Q912	48T40081T03	2SA733 (P)
Q913	48T40081T03	2SA733 (P)
Q914	48T40081T03	2SA733 (P)
Q915	48T40081T03	2SA733 (P)

Symbol No.	Part No.	Description
Diodes		
D101	48S40477U01	1N4003
D103	48S40477U01	1N4003
D104	48S40477U01	1N4003
D110	48T44813F01	MA165TA
D203	48T44813F01	MA165TA
D401	48T44813F01	MA165TA
D402	48T44813F01	MA165TA
D403	48T44813F01	MA165TA
D404	48T44813F01	MA165TA
D501	48T44813F01	MA165TA
D502	48T44813F01	MA165TA
D503	48T44813F01	MA165TA
D504	48T44813F01	MA165TA
D505	48T44813F01	MA165TA
D507	48T44813F01	MA165TA
D508	48T44813F01	MA165TA
D901	48T44813F01	MA165TA
D902	48T44813F01	MA165TA
D903	48T44813F01	MA165TA
D905	48T44813F01	MA165TA
D906	48T44813F01	MA165TA
D907	48T44813F01	MA165TA
D908	48T44813F01	MA165TA
D909	48T44813F01	MA165TA
D910	48T44813F01	MA165TA
D914	48T44813F01	MA165TA
D916	48T44813F01	MA165TA
ZD101	48T40150U80	Zener, HZ20-2
ZD102	48T40150U66	Zener, HZ12B-3
ZD104	48T40150U52	Zener, HZ11A1
ZD105	48T40150U71	Zener, HZ15-2
ZD301	48T40150U68	Zener, HZ12C-2
or	48T40150U69	Zener, HZ12C-3
ZD302	48T40150U68	Zener, HZ12C-2
or	48T40150U69	Zener, HZ12C-3
ZD303	48T40150U32	Zener, HZ6B-2
ZD501	48T40150U32	Zener, HZ6B-2
ZD502	48T40150U76	Zener, HZ18-1
BD101	48T50629F01	Bridge, WL-02
Coils		
L201	24S41448F99	Inductor, Radial 4700 μ H
L202	24S41448F99	Inductor, Radial 4700 μ H
L301	24T47741F01	Inductor, 36 mH
L302	24T47741F01	Inductor, 36 mH
L501	24S41448F97	Inductor, Radial 3300 μ H

Symbol No.	Part No.	Description
L502	24S41448F97	Inductor, Radial 3300 μ H
L503	24T44499P01	Inductor, 27 mH
L504	24T44499P01	Inductor, 27 mH
Transformer		
T501	24T60951F01	O.S.C.
Switches		
S301	40T60152F01	Push SUL 4 KEY (Dolby NR ON/OFF) (Dolby B/C Select) (MPX Filter ON/OFF) (Tape/Source)
S302		
S303		
S401		
Jacks		
J201	09T57396F01	Plate, Phone 4P (JAL) (LINE IN/OUT)
J203	09T60076F01	Jack, Mic
J204	09T60076F01	Jack, Mic
Fuses & Filters		
F101	65T42077U16	Fuse, T-1A
F102	65T42077U16	Fuse, T-1A
LF301	91T57788F01	Filter, MPX.
LF302	91T57788F01	Filter, MPX.
Capacitors		
C101	23S40657F28	Electrolytic 1 μ F/50V
C102	23C44780P24	Electrolytic 2200 μ F/50V
C103	23S41198U57	Electrolytic 470 μ F/25V
C104	23S41198U42	Electrolytic 220 μ F/25V
C105	23S41198U72	Electrolytic 2200 μ F/25V
C106	23S41198U56	Electrolytic 470 μ F/16V
C107	23S40657F14	Electrolytic 100 μ F/16V
C110	23S40657F28	Electrolytic 1 μ F/50V
C112	23S40657F16	Electrolytic 4.7 μ F/25V
C201	08T55260F42	Ceramic 270 pF
C202	08T55260F42	Ceramic 270 pF
C203	23T42478F09	Electrolytic 4.7 μ F/25V
C204	23T42478F09	Electrolytic 4.7 μ F/25V
C205	08T55260F45	Ceramic 470 pF
C206	08T55260F45	Ceramic 470 pF

Symbol No.	Part No.	Description
C207	08T55260F31	Ceramic 56 pF
C208	08T55260F31	Ceramic 56 pF
C209	23S40657F08	Electrolytic 100 μ F/10V
C210	23S40657F08	Electrolytic 100 μ F/10V
C211	08S40656F07	Mylar 3300 pF
C212	08S40656F07	Mylar 3300 pF
C213	23S40657F10	Electrolytic 10 μ F/16V
C214	23S40657F10	Electrolytic 10 μ F/16V
C215	08T55260F45	Ceramic 470 pF
C216	08T55260F45	Ceramic 470 pF
C217	08T55260F49	Ceramic 1000 pF
C218	08T55260F49	Ceramic 1000 pF
C219	08S40656F17	Mylar 0.022 μ F
C220	08S40656F17	Mylar 0.022 μ F
C222	23S40657F10	Electrolytic 10 μ F/16V
C225	08S40656F20	Mylar 0.039 μ F
C226	08S40656F20	Mylar 0.039 μ F
C228	23S40657F21	Electrolytic 100 μ F/25V
C251	08T55260F49	Ceramic 1000 pF
C252	08T55260F49	Ceramic 1000 pF
C253	23S40657F16	Electrolytic 4.7 μ F/25V
C254	23S40657F16	Electrolytic 4.7 μ F/25V
C255	23S40657F10	Electrolytic 10 μ F/16V
C256	23S40657F10	Electrolytic 10 μ F/16V
C301	23S40657F20	Electrolytic 47 μ F/25V
C303	23S40657F16	Electrolytic 4.7 μ F/25V
C304	23S40657F16	Electrolytic 4.7 μ F/25V
C305	23S40657F10	Electrolytic 10 μ F/16V
C306	23S40657F10	Electrolytic 10 μ F/16V
C307	08S40656F04	Mylar 1800 pF
C308	08S40656F04	Mylar 1800 pF
C309	23S40657F52	Electrolytic 220 μ F/16V
C310	23S40657F52	Electrolytic 220 μ F/16V
C311	23S40657F12	Electrolytic 33 μ F/16V
C313	23S40657F11	Electrolytic 22 μ F/16V
C314	23S40657F11	Electrolytic 22 μ F/16V
C317	23S40657F28	Electrolytic 1 μ F/50V
C318	23S40657F28	Electrolytic 1 μ F/50V
C319	23S40657F28	Electrolytic 1 μ F/50V
C320	23S40657F28	Electrolytic 1 μ F/50V
C321	23S40657F08	Electrolytic 100 μ F/10V
C322	23S40657F08	Electrolytic 100 μ F/10V
C323	08S40656F15	Mylar 0.015 μ F
C324	08S40656F15	Mylar 0.015 μ F
C325	23S40657F10	Electrolytic 10 μ F/16V

Symbol No.	Part No.	Description
C326	23S40657F10	Electrolytic 10 uF/16V
C327	08S40656F13	Mylar 0.01 uF
C328	08S40656F13	Mylar 0.01 uF
C329	23S40657F16	Electrolytic 4.7 uF/25V
C330	23S40657F16	Electrolytic 4.7 uF/25V
C331	08S40656F16	Mylar 0.018 uF
C332	08S40656F16	Mylar 0.018 uF
C333	23T42478F21	Electrolytic 0.33 uF/50V
C334	23T42478F21	Electrolytic 0.33 uF/50V
C335	23T42478F21	Electrolytic 0.33 uF/50V
C336	23T42478F21	Electrolytic 0.33 uF/50V
C337	08S40656F15	Mylar 0.015 uF
C338	08S40656F15	Mylar 0.015 uF
C339	23S40657F28	Electrolytic 1 uF/50V
C340	23S40657F28	Electrolytic 1 uF/50V
C341	23S40657F28	Electrolytic 1 uF/50V
C342	23S40657F28	Electrolytic 1 uF/50V
C343	23S40657F10	Electrolytic 10 uF/16V
C344	23S40657F10	Electrolytic 10 uF/16V
C345	08T55260F27	Ceramic 39 pF
C346	08T55260F27	Ceramic 39 pF
C347	08S40656F10	Mylar 5600 pF
C348	08S40656F10	Mylar 5600 pF
C349	08T55260F49	Ceramic 1000 pF
C350	08T55260F49	Ceramic 1000 pF
C351	08S40656F07	Mylar 3300 pF
C352	08S40656F07	Mylar 3300 pF
C353	23S40657F10	Electrolytic 10 uF/16V
C354	23S40657F10	Electrolytic 10 uF/16V
C355	08S40656F08	Mylar 3900 pF
C356	08S40656F08	Mylar 3900 pF
C357	08S40656F24	Mylar 0.082 uF
C358	08S40656F24	Mylar 0.082 uF
C359	23S40657F16	Electrolytic 4.7 uF/25V
C360	23S40657F16	Electrolytic 4.7 uF/25V
C361	23T42478F19	Electrolytic 0.15 uF/50V
C362	23T42478F19	Electrolytic 0.15 uF/50V
C363	23S40657F27	Electrolytic 0.47 uF/50V
C364	23S40657F27	Electrolytic 0.47 uF/50V
C365	23S40657F09	Electrolytic 220 uF/10V
C366	23S40657F09	Electrolytic 220 uF/10V
C369	08S40656F04	Mylar 1800 pF
C370	08S40656F04	Mylar 1800 pF
C371	23S40657F10	Electrolytic 10 uF/16V
C372	23S40657F10	Electrolytic 10 uF/16V

Symbol No.	Part No.	Description
C373	23S40657F10	Electrolytic 10 uF/16V
C401	23S40657F21	Electrolytic 100 uF/25V
C402	23S40657F13	Electrolytic 47 uF/16V
C403	23T42478F19	Electrolytic 0.15 uF/50V
C404	23T42478F19	Electrolytic 0.15 uF/50V
C407	08T55260F25	Ceramic 33 pF
C408	08T55260F25	Ceramic 33 pF
C409	23S40657F10	Electrolytic 10 uF/16V
C410	23S40657F10	Electrolytic 10 uF/16V
C413	23S40657F29	Electrolytic 2.2 uF/50V
C414	23S40657F29	Electrolytic 2.2 uF/50V
C415	08T55260F33	Ceramic 68 pF
C416	08T55260F33	Ceramic 68 pF
C417	23S40657F09	Electrolytic 220 uF/10V
C418	23S40657F09	Electrolytic 220 uF/10V
C501	08T55260F49	Ceramic 1000 pF
C502	08T55260F49	Ceramic 1000 pF
C503	08S44503P06	Mylar 0.0027 uF
C504	08S44503P06	Mylar 0.0027 uF
C505	08T55260F45	Ceramic 470 pF
C506	08T55260F45	Ceramic 470 pF
C507	08S44503P02	Mylar 0.0012 uF
C508	08S44503P02	Mylar 0.0012 uF
C509	08T55260F44	Ceramic 390 pF
C510	08T55260F44	Ceramic 390 pF
C511	08S44503P02	Mylar 0.0012 uF
C512	08S44503P02	Mylar 0.0012 uF
C513	23T42478F09	Electrolytic 4.7 uF/25V
C514	23T42478F09	Electrolytic 4.7 uF/25V
C515	23S40657F10	Electrolytic 10 uF/16V
C516	23S41198U42	Electrolytic 220 uF/25V
C517	23T42478F24	Electrolytic 1 uF/50V
C518	23T42478F24	Electrolytic 1 uF/50V
C519	08S40656F08	Mylar 3900 pF
C520	08S40656F08	Mylar 3900 pF
C521	08S40656F11	Mylar 6800 pF
C522	08S40656F11	Mylar 6800 pF
C523	08S40656F25	Mylar 0.1 uF
C524	08S40656F25	Mylar 0.1 uF
C525	23S40657F16	Electrolytic 4.7 uF/25V
C526	23S40657F16	Electrolytic 4.7 uF/25V
C527	08T55260F43	Ceramic 330 pF
C528	08T55260F43	Ceramic 330 pF
C529	08T55260F35	Ceramic 82 pF
C530	08T55260F35	Ceramic 82 pF

Symbol No.	Part No.	Description
C531	08T55260F49	Ceramic 1000 pF
C532	08T55260F49	Ceramic 1000 pF
C533	08T55260F43	Ceramic 330 pF
C534	08T55260F43	Ceramic 330 pF
C535	08T55260F49	Ceramic 1000 pF
C536	08T55260F49	Ceramic 1000 pF
C537	23S40657F16	Electrolytic 4.7 uF/25V
C538	08T52448F35	Polypropylene, 8200 pF
C539	08S40656F11	Mylar 6800 pF
C540	08S40656F07	Mylar 3300 pF
C541	08S40656F07	Mylar 3300 pF
C542	08S40656F13	Mylar 0.01 uF
C543	23S40657F20	Electrolytic 47 uF/25V
C555	08T55260F43	Ceramic 330 pF
C556	08T55260F43	Ceramic 330 pF
C901	23S40657F28	Electrolytic 1 uF/50V
C903	23S40657F16	Electrolytic 4.7 uF/25V
C904	23S40657F21	Electrolytic 100 uF/25V
C905	23S40657F16	Electrolytic 4.7 uF/25V
C906	23S40657F10	Electrolytic 10 uF/16V
C907	23S40657F16	Electrolytic 4.7 uF/25V
C908	23S40657F18	Electrolytic 22 uF/25V
C909	08S40656F25	Mylar 0.1 uF
C951	23T42477F11	Electrolytic(B.P) 10 uF/25V
Resistors		
R101	06T55177F69	Metal Film 1.5K ohm 1W
R102	06T55177F53	Metal Film 330 ohm 1W
R104	06S55065F89	10K ohm
R201	06S55066F10	68K ohm
R202	06S55066F10	68K ohm
R213	06S55066F14	100K ohm
R214	06S55066F14	100K ohm
R215	06S55065F53	330 ohm
R216	06S55065F53	330 ohm
R219	06S55066F22	220K ohm
R220	06S55066F22	220K ohm
R221	06S55065F97	22K ohm
R222	06S55065F97	22K ohm
R223	06S55065F69	1.5K ohm
R224	06S55065F69	1.5K ohm

Symbol No.	Part No.	Description
R225	06S55066F02	33K ohm
R226	06S55066F02	33K ohm
R227	06S55066F37	910K ohm
R228	06S55066F37	910K ohm
R229	06S55065F81	4.7K ohm
R230	06S55065F81	4.7K ohm
R231	06S55065F97	22K ohm
R232	06S55065F97	22K ohm
R233	06S55065F74	2.4K ohm
R234	06S55065F74	2.4K ohm
R235	06S55065F75	2.7K ohm
R236	06S55065F75	2.7K ohm
R239	06S55065F97	22K ohm
R240	06S55065F97	22K ohm
R241	06S55065F99	27K ohm
R243	06S55065F67	1.2K ohm
R244	06S55065F67	1.2K ohm
R251	06S55065F91	12K ohm
R252	06S55065F91	12K ohm
R253	06S55065F57	470 ohm
R254	06S55065F57	470 ohm
R255	06S55065F89	10K ohm
R256	06S55065F89	10K ohm
R257	06S55066F30	470K ohm
R258	06S55066F30	470K ohm
R259	06S55066F38	1M ohm
R260	06S55066F38	1M ohm
R261	06S55065F89	10K ohm
R262	06S55065F89	10K ohm
R263	06S55066F14	100K ohm
R264	06S55066F14	100K ohm
R301	06S55065F81	4.7K ohm
R302	06S55066F06	47K ohm
R303	06S55065F41	100 ohm
R304	06S55065F41	100 ohm
R307	06S55066F24	270K ohm
R308	06S55066F24	270K ohm
R309	06S55066F06	47K ohm
R310	06S55066F06	47K ohm
R311	06S55065F74	2.4K ohm
R312	06S55065F74	2.4K ohm
R313	06S55065F71	1.8K ohm
R314	06S55065F71	1.8K ohm
R315	06S55066F14	100K ohm
R316	06S55066F14	100K ohm

Symbol No.	Part No.	Description	Symbol No.	Part No.	Description
R319	06T55179F47	Metal Film 180 ohm 2W	R364	06S55065F87	8.2K ohm
R320	06T55179F47	Metal Film 180 ohm 2W	R365	06S55065F84	6.2K ohm
R321	06S55065F81	4.7K ohm	R366	06S55065F84	6.2K ohm
R322	06S55065F83	5.6K ohm	R367	06S55066F12	82K ohm
R323	06S55065F73	2.2K ohm	R368	06S55066F12	82K ohm
R324	06S55065F87	8.2K ohm	R369	06S55065F65	1K ohm
R325	06S55066F02	33K ohm	R370	06S55065F65	1K ohm
R326	06S55066F02	33K ohm	R371	06S55065F77	3.3K ohm
R327	06S55065F97	22K ohm	R372	06S55065F77	3.3K ohm
R328	06S55065F97	22K ohm	R373	06S55065F87	8.2K ohm
R329	06S55066F08	56K ohm	R374	06S55065F87	8.2K ohm
R330	06S55066F08	56K ohm	R375	06S55065F82	5.1K ohm
R331	06S55066F08	56K ohm	R376	06S55065F82	5.1K ohm
R332	06S55066F08	56K ohm	R377	06S55065F87	8.2K ohm
R333	06S55065F82	5.1K ohm	R378	06S55065F87	8.2K ohm
R334	06S55065F82	5.1K ohm	R379	06S55065F83	5.6K ohm
R335	06S55065F93	15K ohm	R380	06S55065F83	5.6K ohm
R336	06S55065F93	15K ohm	R381	06S55065F65	1K ohm
R337	06S55065F47	180 ohm	R401	06S55065F67	1.2K ohm
R338	06S55065F47	180 ohm	R402	06S55065F67	1.2K ohm
R339	06S55066F06	47K ohm	R403	06S55065F89	10K ohm
R340	06S55066F06	47K ohm	R404	06S55065F89	10K ohm
R341	06S55065F84	6.2K ohm	R409	06S55065F72	2K ohm
R342	06S55065F84	6.2K ohm	R410	06S55065F72	2K ohm
R343	06S55066F12	82K ohm	R411	06S55066F30	470K ohm
R344	06S55066F12	82K ohm	R412	06S55066F30	470K ohm
R345	06S55065F41	100 ohm	R413	06S55065F99	27K ohm
R346	06S55065F41	100 ohm	R414	06S55065F99	27K ohm
R347	06S55066F38	1M ohm	R415	06S55066F14	100K ohm
R348	06S55066F38	1M ohm	R416	06S55066F14	100K ohm
R349	06S55065F82	5.1K ohm	R425	06S55065F53	330 ohm
R350	06S55065F82	5.1K ohm	R426	06S55065F53	330 ohm
R351	06S55065F89	10K ohm	R427	06S55065F81	4.7K ohm
R352	06S55065F89	10K ohm	R428	06S55065F81	4.7K ohm
R353	06S55066F10	68K ohm	R429	06S55065F55	390 ohm
R354	06S55066F10	68K ohm	R430	06S55065F55	390 ohm
R355	06S55065F81	4.7K ohm	R431	06S55066F12	82K ohm
R356	06S55065F81	4.7K ohm	R432	06S55066F12	82K ohm
R357	06S55065F50	240 ohm	R435	06T55177F53	Metal Film 330 ohm 1W
R358	06S55065F50	240 ohm	R436	06T55177F53	Metal Film 330 ohm 1W
R359	06S55066F08	56K ohm	R437	06T55175F29	Metal Film 33 ohm 1/2W
R360	06S55066F08	56K ohm	R438	06T55175F29	Metal Film 33 ohm 1/2W
R361	06S55065F49	220 ohm	R439	06S55065F89	10K ohm
R362	06S55065F49	220 ohm	R440	06S55065F89	10K ohm
R363	06S55065F87	8.2K ohm	R443	06S55065F65	1K ohm

Symbol No.	Part No.	Description
R444	06S55065F65	1K ohm
R501	06S55066F02	33K ohm
R502	06S55066F02	33K ohm
R503	06S55066F01	30K ohm
R504	06S55066F01	30K ohm
R505	06S55066F12	82K ohm
R506	06S55066F12	82K ohm
R507	06S55066F04	39K ohm
R508	06S55066F04	39K ohm
R509	06S55066F07	51K ohm
R510	06S55066F07	51K ohm
R511	06S55065F99	27K ohm
R512	06S55065F99	27K ohm
R513	06S55065F89	10K ohm
R514	06S55065F89	10K ohm
R515	06S55066F10	68K ohm
R516	06S55066F10	68K ohm
R517	06S55066F10	68K ohm
R518	06S55066F10	68K ohm
R519	06S55066F10	68K ohm
R520	06S55066F10	68K ohm
R521	06S55066F06	47K ohm
R522	06S55066F06	47K ohm
R523	06S55066F08	56K ohm
R524	06S55066F08	56K ohm
R525	06S55065F77	3.3K ohm
R526	06S55065F77	3.3K ohm
R527	06S55065F99	27K ohm
R528	06S55065F99	27K ohm
R531	06S55065F41	100 ohm
R532	06S55065F41	100 ohm
R533	06S55065F89	10K ohm
R534	06S55065F89	10K ohm
R537	06S55065F41	100 ohm
R538	06S55065F41	100 ohm
R539	06S55066F02	33K ohm
R540	06S55066F02	33K ohm
R541	06S55066F20	180K ohm
R542	06S55066F20	180K ohm
R543	06S55065F81	4.7K ohm
R544	06S55065F81	4.7K ohm
R545	06S55066F38	1M ohm
R546	06S55066F38	1M ohm
R547	06S55065F89	10K ohm
R548	06S55065F89	10K ohm

Symbol No.	Part No.	Description
R549	06S55065F89	10K ohm
R550	06S55065F89	10K ohm
R551	06S55065F81	4.7K ohm
R552	06S55065F01	2.2 ohm
R553	06T55175F13	Metal Film 6.8 ohm 1/2W
R554	06T55175F13	Metal Film 6.8 ohm 1/2W
R555	06S55065F97	22K ohm
R556	06S55065F97	22K ohm
R557	06S55065F49	220 ohm
R558	06S55065F49	220 ohm
R559	06S55065F77	3.3K ohm
R560	06S55065F89	10K ohm
R561	06S55065F75	2.7K ohm
R567	06S55065F17	10 ohm
R568	06S55065F17	10 ohm
R630	06S55065F97	22K ohm
R631	06S55065F75	2.7K ohm
R632	06S55065F89	10K ohm
R851	06S55065F67	1.2K ohm
R852	06S55065F67	1.2K ohm
R853	06S55065F67	1.2K ohm
R854	06S55065F67	1.2K ohm
R855	06S55065F67	1.2K ohm
R856	06S55065F67	1.2K ohm
R857	06S55065F67	1.2K ohm
R858	06S55065F67	1.2K ohm
R859	06S55065F67	1.2K ohm
R901	06S55065F89	10K ohm
R902	06S55065F89	10K ohm
R903	06S55065F97	22K ohm
R904	06S55065F97	22K ohm
R905	06S55065F97	22K ohm
R906	06S55065F89	10K ohm
R907	06S55065F89	10K ohm
R908	06S55065F89	10K ohm
R909	06S55065F81	4.7K ohm
R910	06S55065F97	22K ohm
R911	06S55065F97	22K ohm
R912	06S55066F06	47K ohm
R913	06S55065F89	10K ohm
R914	06S55065F89	10K ohm
R917	06S55065F87	8.2K ohm
R918	06S55065F73	2.2K ohm
R919	06S55065F97	22K ohm
R920	06S55066F02	33K ohm

Symbol No.	Part No.	Description
R921	06S55065F97	22K ohm
R922	06S55065F97	22K ohm
R924	06S55065F97	22K ohm
R925	06S55065F93	15K ohm
R927	06S55066F02	33K ohm
R928	06S55065F81	4.7K ohm
R929	06S55065F89	10K ohm
R930	06S55065F89	10K ohm
R931	06S55065F89	10K ohm
R932	06S55065F89	10K ohm
R933	06S55065F89	10K ohm
R934	06S55065F89	10K ohm
R935	06S55065F89	10K ohm
R936	06S55065F89	10K ohm
R937	06S55065F89	10K ohm
R952	06S55066F14	100K ohm
R953	06S41801P64	470K ohm 1/4W
R954	06S55066F30	470K ohm
R956	06S55066F02	33K ohm
VR201	18T52946F15	Variable 22K ohm
VR202	18T52946F15	Variable 22K ohm
VR401	18T60151F01	Variable, Rotary 5K ohm A
VR403	18T52946F13	Variable 10K ohm
VR404	18T52946F13	Variable 10K ohm
VR501	18T52946F17	Variable 47K ohm (OUTPUT LEVEL)
VR502	18T52946F17	Variable 47K ohm
VR503	18T52946F19	Variable 100K ohm
VR504	18T52946F19	Variable 100K ohm
VR505	18B44064J07	Variable 100K ohm 1/2W
VR506	18B44064J07	Variable 100K ohm 1/2W
VR507	18T60150F01	Variable, Rotary 1K ohm B (BIAS FINE)
VR508	18T52946F09	Variable 2.2K ohm
Control P.C. Board		
IC		
IC601	51S47110F01	BA843
Transistors		
Q103 or Q601 or	48T43015U01 48S40832F03 48T43015U01 48S40832F03	2SC2120-Y 2SC1318NC-R 2SC2120-Y 2SC1318NC-R

Symbol No.	Part No.	Description
Q602 or Q603 or	48T43015U01 48S40832F03 48T43015U01 48S40832F03	2SC2120-Y 2SC1318NC-R 2SC2120-Y 2SC1318NC-R
Q605 or Q606 or Q607 or	48S43525F05 48S44578J01 48S43525F05 48S44578J01 48S43525F05 48S44578J01	2SC1815-Y, GR 2SC945LP 2SC1815-Y, GR 2SC945LP 2SC1815-Y, GR 2SC945LP
Q608 or Q610 or Q611 or	48S43525F05 48S44578J01 48S43525F05 48S44578J01 48S43525F05 48S44578J01	2SC1815-Y, GR 2SC945LP 2SC1815-Y, GR 2SC945LP 2SC1815-Y, GR 2SC945LP
Q612 or Q613 or Q614 or	48S43525F05 48S44578J01 48S43525F05 48S44578J01 48S43525F05 48S44578J01	2SC1815-Y, GR 2SC945LP 2SC1815-Y, GR 2SC945LP 2SC1815-Y, GR 2SC945LP
Q615 or Q916 Q917 or	48S43525F05 48S44578J01 48T60583F01 48S43525F05 48S44578J01	2SC1815-Y, GR 2SC945LP DTA114N 2SC1815-Y, GR 2SC945LP
Q918 or Q919 or Q920 or	48S43525F05 48S44578J01 48S43525F05 48S44578J01 48S43525F05 48S44578J01	2SC1815-Y, GR 2SC945LP 2SC1815-Y, GR 2SC945LP 2SC1815-Y, GR 2SC945LP
Q921	48T60583F01	DTA114N
Diodes		
D601 D602 D603 D605 or	48S40477U01 48S40477U01 48S40477U01 48T58583F01 48T44813F01	1N4003 1N4003 1N4003 SS176 MA165TA

Symbol No.	Part No.	Description
D606 or D607 or D615 or	48T58583F01 48T44813F01 48T58583F01 48T44813F01 48T58583F01 48T44813F01	SS176 MA165TA SS176 MA165TA SS176 MA165TA
D616 or D617 D618 or	48T58583F01 48T44813F01 48T57425F01 48T58583F01 48T44813F01	SS176 MA165TA 1M60FM SS176 MA165TA
D911 or D912 or D913 or	48T58583F01 48T44813F01 48T58583F01 48T44813F01 48T58583F01 48T44813F01	SS176 MA165TA SS176 MA165TA SS176 MA165TA
ZD103	48T40150U32	Zener, HZ6B-2
Jack		
J601	09T50261F01	JACK (REMOTE)
Capacitors		
C108 C109 C602 C603 C604	23S40657F10 23S40657F10 23S40657F10 23S40657F09 23S40657F09	Electrolytic 10 uF/16V Electrolytic 10 uF/16V Electrolytic 10 uF/16V Electrolytic 220 uF/10V Electrolytic 220 uF/10V
C606 C607 C608 C610 C611	23S40657F10 08T55260F61 23S40657F09 23S40657F14 08T55260F61	Electrolytic 10 uF/16V Ceramic 0.01 uF Electrolytic 220 uF/10V Electrolytic 100 uF/16V Ceramic 0.01 uF
C612 C613 C614 C615 C616	08T55260F61 08T55260F61 08T55260F61 08T55260F61 08T55260F61	Ceramic 0.01 uF Ceramic 0.01 uF Ceramic 0.01 uF Ceramic 0.01 uF Ceramic 0.01 uF

Symbol No.	Part No.	Description
C617 C627 C910 C911	23S40657F13 08T55260F61 23S40657F16 23S40657F28	Electrolytic 47 uF/16V Ceramic 0.01 uF Electrolytic 4.7 uF/25V Electrolytic 1 uF/50V
Resistors		
R103 R601 R602 R603 R604	06S55065F63 06S55065F73 06S55065F59 06S55065F59 06S55065F53	820 ohm 2.2K ohm 560 ohm 560 ohm 330 ohm
R605 R606 R609 R610 R615	06S55065F53 06S55065F59 06S55066F06 06S55066F06 06S55065F85	330 ohm 560 ohm 47K ohm 47K ohm 6.8K ohm
R616 R617 R618 R619 R621	06S55065F91 06S55065F93 06S55065F89 06S55065F77 06S55065F87	12K ohm 15K ohm 10K ohm 3.3K ohm 8.2K ohm
R622 R623 R624 R625 R626	06S55065F87 06S55066F04 06S55066F02 06S55065F41 06S55065F53	8.2K ohm 39K ohm 33K ohm 100 ohm 330 ohm
R627 R628 R629 R938 R941	06S55065F77 06S55066F06 06S55066F02 06S55065F89 06S55065F89	3.3K ohm 47K ohm 33K ohm 10K ohm 10K ohm
R942 R943 R944 R946 R947	06S55065F97 06S55065F97 06S55065F77 06S55065F89 06S55065F89	22K ohm 22K ohm 3.3K ohm 10K ohm 10K ohm
R948 R949	06S55065F89 06S55065F89	10K ohm 10K ohm

Symbol No.	Part No.	Description
Keyboard Switch P.C. Board		
Diode		
LD603	48T60946F01	LED, LD-603VR (RED)(REC)
Switches		
S601	40T44505F01	Switch, KHG (PLAY)
S602	40T44505F01	Switch, KHG (STOP)
S603	40T44505F01	Switch, KHG (FF)
S604	40T44505F01	Switch, KHG (REW)
S605	40T44505F01	Switch, KHG (PAUSE)
S606	40T44505F01	Switch, KHG (REC)
S607	40T44505F01	Switch, KHG (REC MUTE)
S610	40T61322F01	Switch, KHG 10904 (Metal 50)
Meter P.C. Board		
IC's		
IC801	51T60489F01	BA682A
IC802	51T60489F01	BA682A
Resistors		
R801	06S44594P23	240K ohm 1/4W
R802	06S44594P23	240K ohm 1/4W
R803	06S44593P99	27K ohm 1/4W
R804	06S44593P99	27K ohm 1/4W
R805	06S44593P89	10K ohm 1/4W
R806	06S44593P89	10K ohm 1/4W
R807	06S44593P89	10K ohm 1/4W
R808	06S44593P89	10K ohm 1/4W
R809	06S44593P61	680 ohm 1/4W
R810	06S44593P61	680 ohm 1/4W
R821	06S44593P47	180 ohm 1/4W
R822	06S44593P47	180 ohm 1/4W
VR203	18T60079F01	VR, Slide 20K ohm A
VR801	18T52946F17	Variable 47K ohm
VR802	18T52946F17	Variable 47K ohm

Symbol No.	Part No.	Description
Capacitors		
C801	23S40657F29	Electrolytic 2.2 uF/50V
C802	23S40657F29	Electrolytic 2.2 uF/50V
C803	23S40657F05	Electrolytic 22 uF/10V
C804	23S40657F05	Electrolytic 22 uF/10V
Miscellaneous Parts		
C1	08T57437F09	Cap, Ceramic 0.01 uF
J101	09T60095F01	Socket, AC
J401	09T60076F02	Jack, Head Phase
HD201	88T57524F01	Head R/P Combination
HD502		
HD501	FU163-13	Head, Erase
LD601	48T45518F01	LED, 1331G (Grn) (PLAY)
LD602	48T45519F01	LED, 1741Y (Yel) (PAUSE)
LD801	48T60485F01	LED, SLR-34MG3 (Grn) (Level Meter)
LD802	48T60485F01	LED, SLR-34MG3 (Grn) (Level Meter)
LD803	48T60485F01	LED, SLR-34MG3 (Grn) (Level Meter)
LD804	48T60485F01	LED, SLR-34MG3 (Grn) (Level Meter)
LD805	48T60485F01	LED, SLR-34MG3 (Grn) (Level Meter)
LD806	48T60485F01	LED, SLR-34MG3 (Grn) (Level Meter)
LD807	48T60485F01	LED, SLR-34MG3 (Grn) (Level Meter)
LD808	48T60485F01	LED, SLR-34MG3 (Grn) (Level Meter)
LD809	48T60485F01	LED, SLR-34MG3 (Grn) (Level Meter)
LD810	48T60485F01	LED, SLR-34MG3 (Grn) (Level Meter)
LD811	48T60485F01	LED, SLR-34MG3 (Grn) (Level Meter)
LD812	48T60485F01	LED, SLR-34MG3 (Grn) (Level Meter)

Symbol No.	Part No.	Description	Symbol No.	Part No.	Description
LD813	48T60485F01	LED, SLR-34MG3 (Grn) (Level Meter)	Q101 or Q102 or Q104 or	48T56031F01 48T58614F01 48T56031F01 48T58614F01 48S43525F05 48S44578J01	Transistor, 2SD1266-P, Q Transistor, 2SD1406 Transistor, 2SD1266-P, Q Transistor, 2SD1406 Transistor, 2SC1815-Y, GR Transistor, 2SC945L-P
LD814	48T60485F01	LED, SLR-34MG3 (Grn) (Level Meter)	Q105 or	48S43525F05 48S44578J01	Transistor, 2SC1815-Y, GR Transistor, 2SC945L-P
LD815	48T60485F01	LED, SLR-34MG3 (Grn) (Level Meter)	S101	40T45561F02	Switch, Power (SDL1P)
LD816	48T60485F01	LED, SLR-34MG3 (Grn) (Level Meter)	S201	FE173-11	Slide Switch (Metal)
LD817	48T60486F01	LED, SLR-34DU3 (AMB) (Level Meter)	S202	FE173-11	Slide Switch (70 μ s)
LD818	48T60486F01	LED, SLR-34DU3 (AMB) (Level Meter)	S611	FE173-11	Slide Switch (AR)
LD819	48T60486F01	LED, SLR-34DU3 (AMB) (Level Meter)	S612	FE173-11	Slide Switch (Pack)
LD820	48T60486F01	LED, SLR-34DU3 (AMB) (Level Meter)	S613	40T47104F01	Switch, Reed
LD821	48T60486F01	LED, SLR-34DU3 (AMB) (Level Meter)	S616	40T55489F01	Switch, Slide SSA (Timer Switch)
LD822	48T60486F01	LED, SLR-34DU3 (AMB) (Level Meter)	S901	40T50262F01	Switch, Slide (Timer Metal 50 Select Switch)
LD823	48T60486F01	LED, SLR-34DU3 (AMB) (Level Meter)	SD601	F082-046	Solenoid (Play)
LD824	48T60486F01	LED, SLR-34DU3 (AMB) (Level Meter)	SD602	PKA16106	Solenoid (FF)
LD825	48T60486F01	LED, SLR-34DU3 (AMB) (Level Meter)	SD603	PKA16106	Solenoid (REW)
LD826	48T60486F01	LED, SLR-34DU3 (AMB) (Level Meter)	T101	25T60094F01	Trans, Power
LD827	48T60486F01	LED, SLR-34DU3 (AMB) (Metal 50)			
LD828	48T60485F01	LED, SLR-34MG3 (Grn) (Metal)			
LD829	48T60485F01	LED, SLR-34MG3 (Grn) (CrO ₂)			
LD830	48T60485F01	LED, SLR-34MG3 (Grn) (Normal)			
LD831	48T60485F01	LED, SLR-34MG3 (Grn) (Tape)			
LD832	48T60486F01	LED, SLR-34DU3 (AMB) (Source)			
LD833	48T60485F01	LED, SLR-34MG3 (Grn) (Dolby B)			
LD834	48T60486F01	LED, SLR-34DU3 (AMB) (Dolby C)			
LD835	48T60485F01	LED, SLR-34MG3 (Grn) (MPX Filter ON)			
M601	F064-093	Assembly, Motor			
PL101	65C42544U04	Lamp, Pilot 14V-50mA (Cassette)			

Cabinet Assembly Parts List

Symbol No.	Index	Part No.	Description	Symbol No.	Index	Part No.	Description
1	2-A	15D58926F02	Cover, Top	41	3-F	※	Power P.C. Board
2		03S40036U16	Screw, W/Washer (M4 x 6)	42		※	Heat Sink 1650MT
3	3-A	01B60087F02	Assembly, Door	43	3-F	※	Reed Switch P.C. Board
4	4-A	54C61105F02	Sheet, Display	44	3-F	07C58941F01	Frame, Volume
5	4-A	01V61200F37	Assembly, Front Panel	45	4-F	64A58934F01	Plate, Volume
6	4-A	03S40012G26	Screw, Tapping (M3 x 6)	46	4-F	※	Assembly, Master P.C. Board
7	4-B	01V61200F35	Assembly, Key Board	47	1-H	03S43997P88	Screw, Bind (M2 x 6)
8	5-B	26A61725F01	Shield, Static	48	2-G	29A41814G01	Lug
9		03S40012G48	Screw, Tapping (M3 x 6)	49	2-G	09T45548F01	Holder, Fuse
10		03S40011G17	Screw, Pan (M3 x 6)	50	4-G	※	Chassis, Side
11	4-C	36A60235F01	Knob, Power	51	4-G	※	Cover, Bottom
12	4-C	36A55392F02	Knob, Slide Switch	52		03S44205G16	Screw, Countersink (M3 x 6)
13	4-C	03C40014G12	Screw, W/Washer (M2.6 x 4)	53	1-F	43A44685F01	Spacer, Switch
14		03S40012G59	Screw, Tapping (M2.6 x 6)	54	5-D	03S44205G19	Screw, Pan (M3 x 8)
15	5-C	01C60172F01	Assembly, Front Eschution	55	5-E	43A62489F01	Spacer, Volume
16	5-C	36A60109F01	Knob, Rotary	56	5-E	03S40012G47	Screw, Tapping (M2.6 x 8)
17	1-H	03S40012G41	Screw Tapping (M3 x 8)	57	4-B	04S40070G22	Washer, Flat (M2.6)
18	1-C	01V61200F29	Assembly, Meter P.C. Board	58	2-C	26A62457F01	Shield, Static
19	2-C	01V61200F32	Assembly, Dust Cover	59	3-G	26A61682F01	Shield, Pre-Amp
20	2-C	03S44205G32	Screw, Bind (M3 x 5)	60	2-F	01V61900F05	Assembly, Control P.C. Board
21	2-C	43T53136F01	Bush, Cap TP150-301				
22	5-C	01C60173F01	Assembly, Meter Frame				
23	5-C	01A60930F01	Assembly, Knob Record				
24	1-D	43A51937F01	Spacer, Eject				
25	2-D	81T60236F01	Cassette Deck (FL87E32G)				
27		75A60070F01	Pad, Rubber				
28	5-D	36A52480F03	Knob, Push				
29	3-E	※	Timer Switch P.C. Board				
30	3-E	※	Headphone P.C. Board				
31	3-E	※	Bracket, Counter				
32	4-E	72T60041F01	Tape, Counter				
33	5-E	36A55519F01	Knob, Push				
34	1-E	42A45366F01	Belt, Counter				
35	3-E	※	Chassis, Bottom				
36	4-E	03S43997P29	Screw, Pan (M3 x 5)				
37	4-E	36A58935F01	Knob, Slide Volume				
38	5-E	※	Chassis, Front				
39	1-F	15C58925F02	Cover, Rear				
40		05B41635J02	Rivet Push				

NOTE: ※ The parts whose parts numbers are not entered will not be supplied.

Exploded View (Cabinet)

LD827	LD801	803	805	807	809	811	813	815	817	819	821	823	825
828	802	804	806	808	810	812	814	816	818	820	822	824	826
829													
830	LD831		LD832	833	834	835							

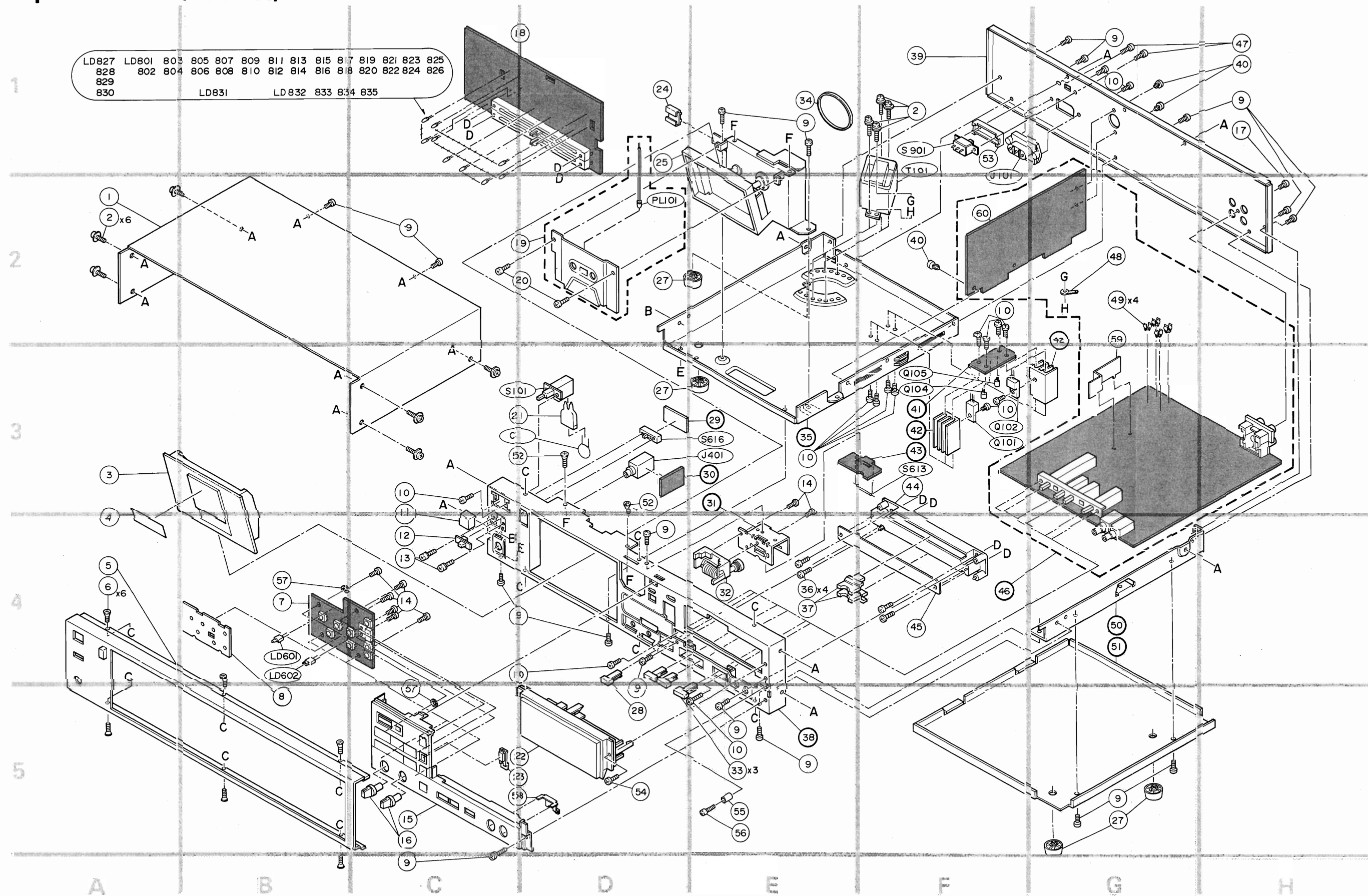

Exploded View (Cassette Deck)

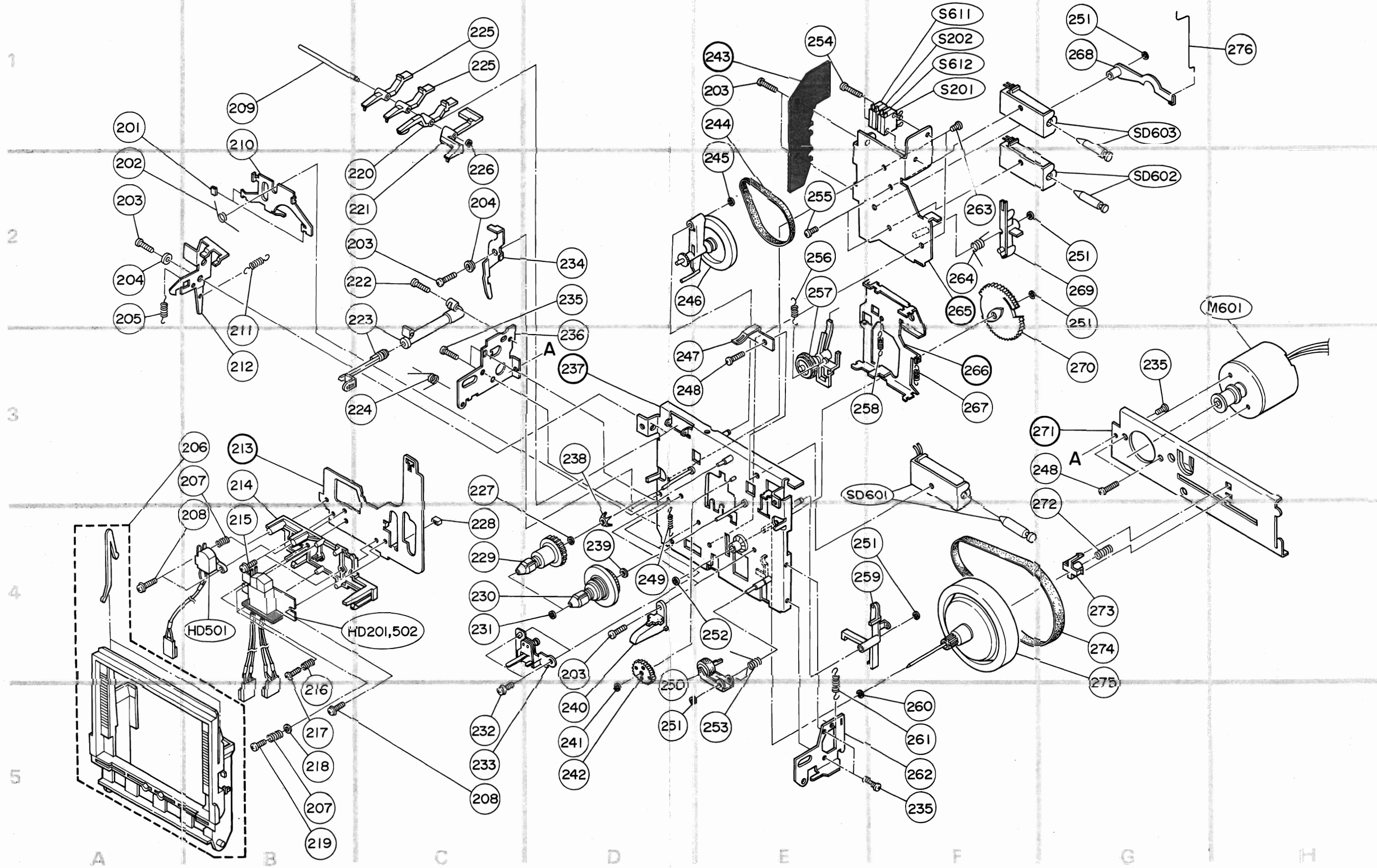

Cassette Deck Assembly Parts List

Symbol No.	Index	Part No.	Description	Symbol No.	Index	Part No.	Description
201	1-A	FF11C-14	Rubber, Brake	241	5-D	FJ123-14	Polyslider
202	2-A	FK12A-12	Spring, Brake	242	5-D	FN154-14	Gear, Idler
203		KG194-12	Screw, Pan (M3 x 6)	243	1-E	※	Connector, P.C. Board
204		FM296-11	Spacer	244	1-E	FP463-11	Belt, Sub
205	2-A	FK573-11	Spring, Arm Lock	245	2-E	FJ123-19	Washer, Lock
206	3-B	F027-062	Frame, Door Assembly	246	2-D	FP470-11	Assembly, Clutch
207		FK572-11	Spring, Azimuth	247	3-D	FK551-13	Spring, Cassette
208		UG11K-11	Screw, Bind (M2 x 11.5)	248	3-D	FG114-15	Screw, W/Washer (M2.6 x 4)
209	1-B	FL25F-11	Shaft (A)	249	4-D	FK578-13	Spring, Head Base Hold
210	1-B	FC15G-14	Lever, Brake	250	5-D	F014-053	Assembly, Pinch Roller
211	3-B	FK18M-11	Spring, Arm Eject	251		FJ123-21	Washer, Lock
212	3-B	FC32U-11	Arm, Eject Lock	252	4-E	FJ141-12	Washer, Oil Shield
213	3-B	※	Plate, Head Assembly	253	5-E	FK569-14	Spring, Pinch Roller
214	3-B	FD14U-16	Spacer, Head	254	1-E	FG143-30	Screw, Pan (M2.6 x 30)
215	4-B	FG137-13	Screw, F-Lock	255	2-E	FG143-17	Screw, Pan
216	5-B	FK11F-23	Tilt, Spring	256	2-E	FK575-11	Spring, Play Idler
217	5-B	UG11M-11	Screw, Tilt	257	2-E	FP469-12	Assembly, Idler
218	5-B	FJ151-11	Washer, Flat	258		FK577-13	Spring, Head Base
219	5-B	UG11K-12	Screw, Bind (M2 x 18)	259	4-F	FR359-12	Arm, Play Solenoid
220	2-C	FD26K-11	Arm, Cassette	260	5-F	FJ111-40	Washer, Polyslider
221	2-C	FD26M-11	Arm (M)	261	5-F	FK576-12	Spring, Play Solenoid Arm
222	2-C	UG11D-11	Screw, Tap Tite (M2 x 12)	262	5-F	FR350-15	Bracket, Door
223	2-C	FP472-11	Assembly, Damper	263	2-F	KG194-46	Screw, Tap Tite (M3 x 4.5)
224	3-C	FK568-11	Spring, Door	264	2-F	FK570-12	Spring, Bracket Solenoid
225		FD26L-11	Arm, Record	265	2-F	※	Bracket, Solenoid Assembly
226	2-C	KG111-19	Ring, "E"	266	3-F	※	Base, Assist
227	3-C	FJ111-18	Washer, Polyslider	267	3-F	FK574-13	Spring, Base Assist
228	4-C	FP464-11	Pad, Cushion	268	1-G	FD12W-12	Arm, Brake
229	4-C	F105-019	Assembly, Reel	269	2-G	FR355-15	Arm, FF Solenoid
230	4-C	F123-025	Assembly, Take UP Reel	270	3-G	FN153-11	Gear, Play
231	4-C	FJ111-17	Washer, Polyslider	271	3-G	※	Bracket, Motor
232	5-C	FG137-12	Screw, F-Lock (M2 x 4)	272	4-G	FK11F-16	Spring, Srast
233	5-C	FR13V-12	Assembly, Tension Arm	273	4-G	FM281-12	Spacer, Flywheel
234	2-D	FR352-11	Lever, Safety	274	4-G	FP462-11	Belt, Main
235		KG189-11	Screw, Pan	275	4-G	FR13L-11	Assembly, Flywheel
236	3-D	FR349-17	Bracket, Damper	276	1-H	FK11Y-13	Brake, Rod
237	3-D	※	Assembly, Chassis				
238	3-D	FK579-15	Spring, Back Tension				
239	4-D	FJ111-12	Washer, Polyslider				
240	5-D	FR360-12	Guide, Cassette				

NOTE: ※ The parts whose parts numbers are not entered will not be supplied.

Semi-Conductor Lead Identifications

HA12038: IC301, 302

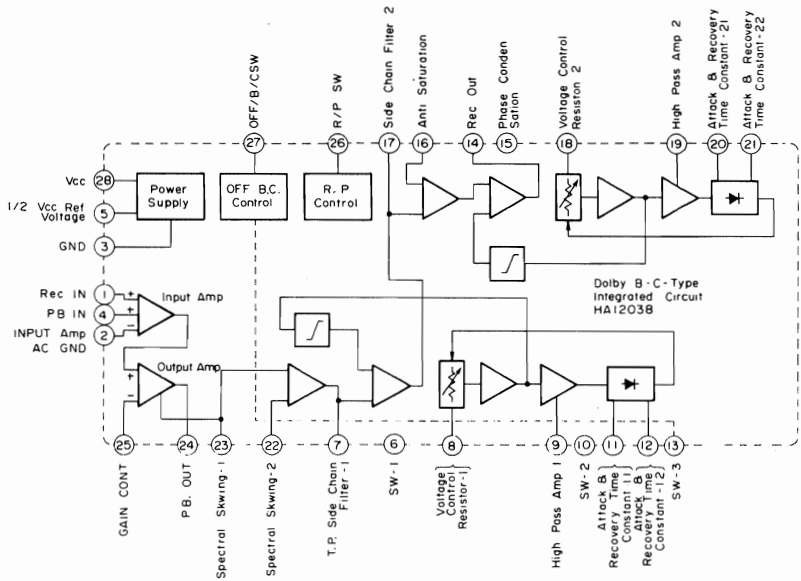
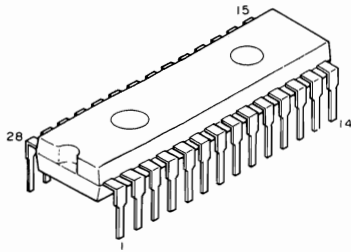

μPC4558C: IC401, 501

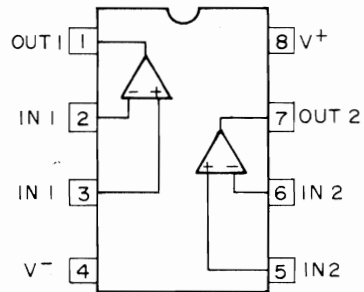
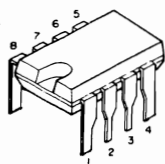

BA843: IC601

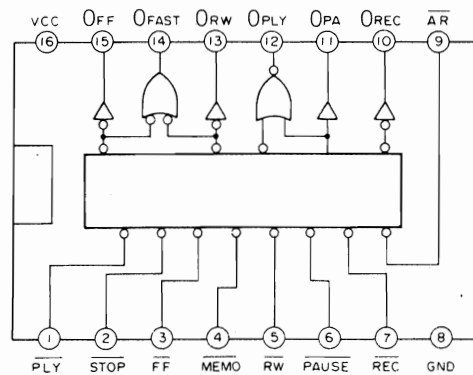
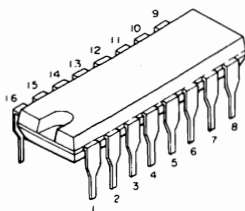

IC	IC501							IC301 IC302		
Transistor (Q)	Q251, Q252, Q207, Q209 Q208, Q210 Q509 Q510 Q511, Q512, Q513, Q514, Q515	Q211 Q212	Q213 Q214	Q501, Q503, Q505 Q516, Q517	Q301, Q302 Q502, Q504, Q506 Q901, Q902	Q303 Q903, Q905 Q907, Q908 Q909, Q910	Q904, Q906 Q911	Q912 Q913	Q914 Q915 Q101, Q104 Q102, Q105	Q6
Diode (D, BD, ZD, LD)	ZD502	D507 D508	D203	D505 D501	D504 D502	ZD501 D503 D902	ZD302 D901 D903	ZD301 D906 D916, D907 D914	ZD303 D905 D908, D909, D910	D110 ZD101, ZD104

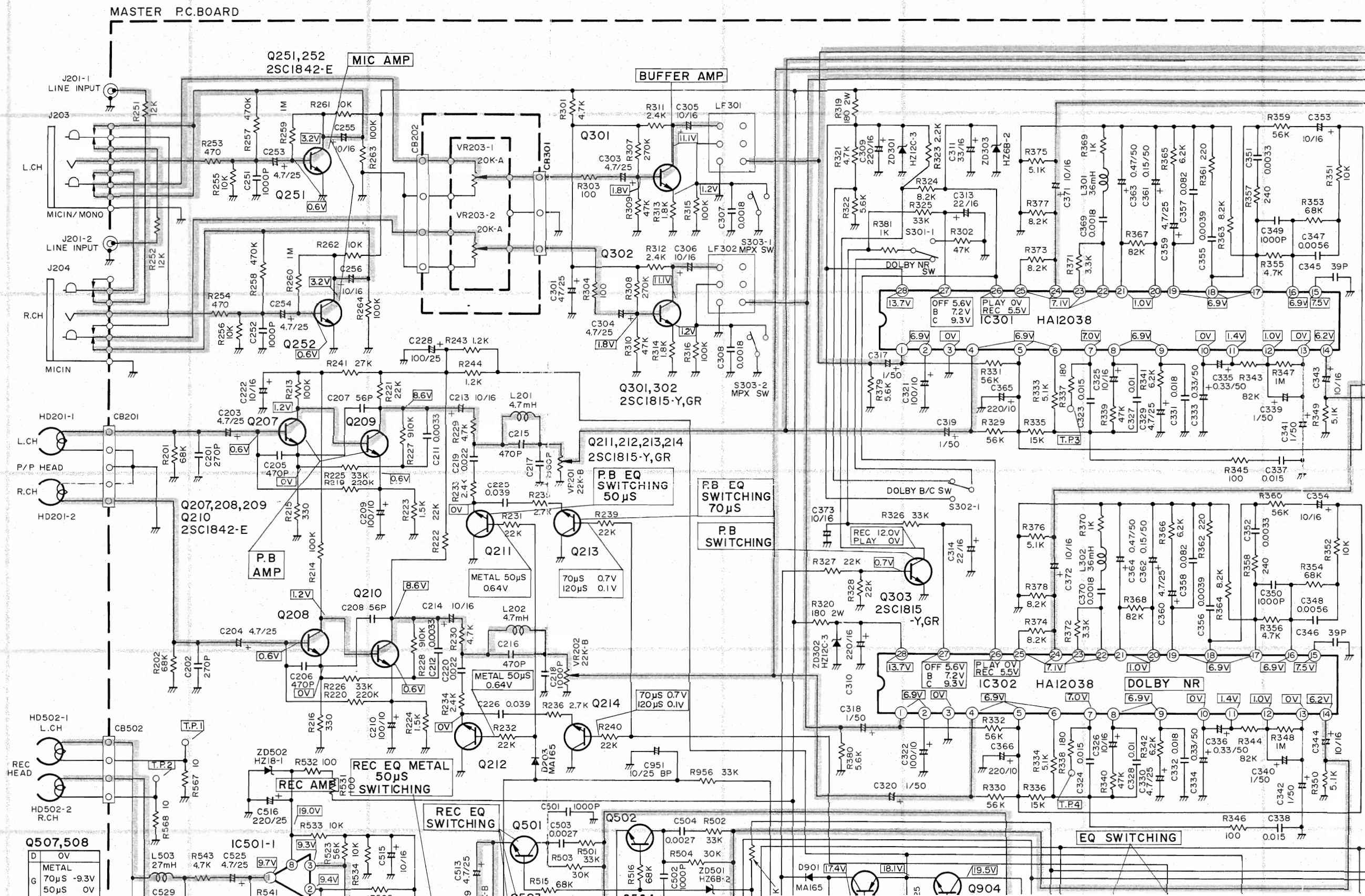

D	OV
METAL	70µs -9.3V
G	50µs OV

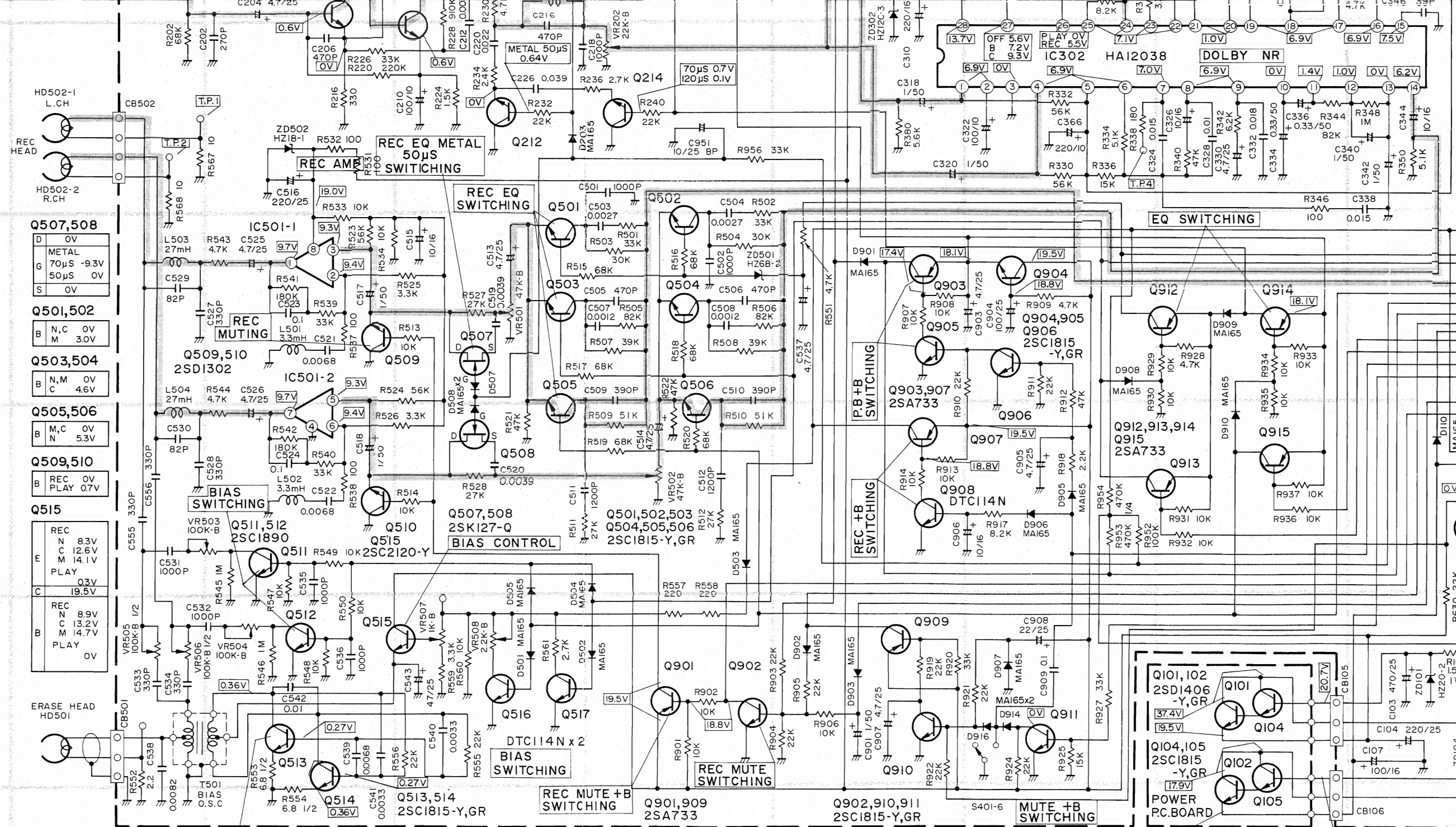

Q507,508	D 0V
	METAL 70μS -9.3V
	50μS 0V
	S 0V
Q501,502	B N,C 0V
	M 3.0V
Q503,504	B N,M 0V
	C 4.6V
Q505,506	B M,C 0V
	N 5.3V
Q509,510	B REC 0V
	PLAY 0.7V
Q515	REC N 8.3V
	C 12.6V
	M 14.1V
	PLAY 0.3V
	C 19.5V
	REC N 8.9V
	C 13.2V
	M 14.7V
	PLAY 0V

Q511,512	B M 0V
	N,C 0.7V
Q516	B N 18.3V
	C,M 0V
Q517	B N,M 0V
	C 17.4V
Q902	B PLAY 0.7V
	REC 0V
Q903	C REC -9.26V
	PLAY 0V
Q905	B PLAY 0.7V
	REC 0V
Q906	B REC 0.6V
	PLAY 0V
Q907	C REC 19.5V
	PLAY -9.27V
Q908	B REC 2.8V
	PLAY 0V
Q911	B PLAY 0.6V
	STOP POUSE 0V
Q912	N 0V
	C 0.6V
	M 17.2V

NOTES:
 1. All resistance values are in ohms. K = 1,000
 2. All capacitance values are in microfarads. P = $\frac{1}{1,000,000}$

IC401										IC601										IC801									
Q914, Q915, Q101, Q104, Q102, Q105										Q401, Q403, Q402, Q404, Q405, Q406, Q103, Q606, Q605, Q611, Q610, Q608, Q607										Q407, Q408, Q612, Q916, Q917, Q919, Q615, Q613, Q918, Q920, Q614, Q921									
D110, ZD101, ZD104										D603, D401, D403, D402, D404, D602, D601, ZD103, D605, D606, D607, D911, D912, D818										LD831, LD832, LD835, LD834, LD833, LD827, LD828, LD801, LD803, LD805, LD807, LD809, LD811, LD813, LD815, LD817, LD825, LD823, LD821, LD819, LD802, LD804, LD806, LD808, LD810, LD812, LD814, LD816, LD826, LD824, LD822, LD820, LD818, LD601, LD602, LD603									

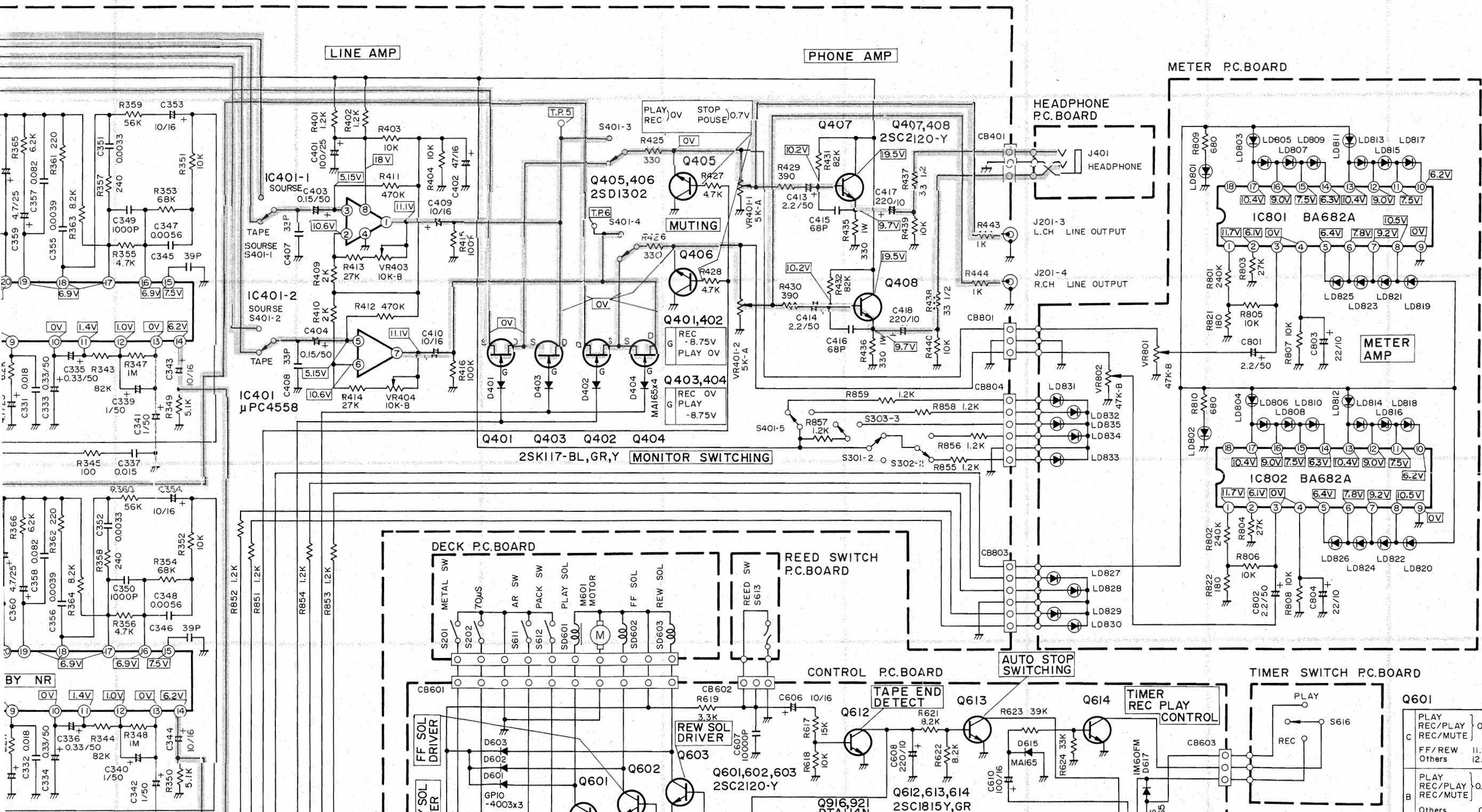

Q909 (Tape Position)

REC PLAY	0V
STOP PAUSE	19.5V

C

POWER ON

19.5V

3sec

REC PLAY	20.2V
STOP PAUSE	18.8V

B

REC PLAY	19.5V
STOP PAUSE	0V

C

REC PLAY	0V
STOP PAUSE	0.68V

B

Q910 (Tape Position)

REW	0.1V
PLAY	11.9V
REC/PLAY	11.9V
REC/MUTE	12.0V
FF	12.0V

C

Others	12.0V
--------	-------

B

REW	0.8V
Others	0V

B

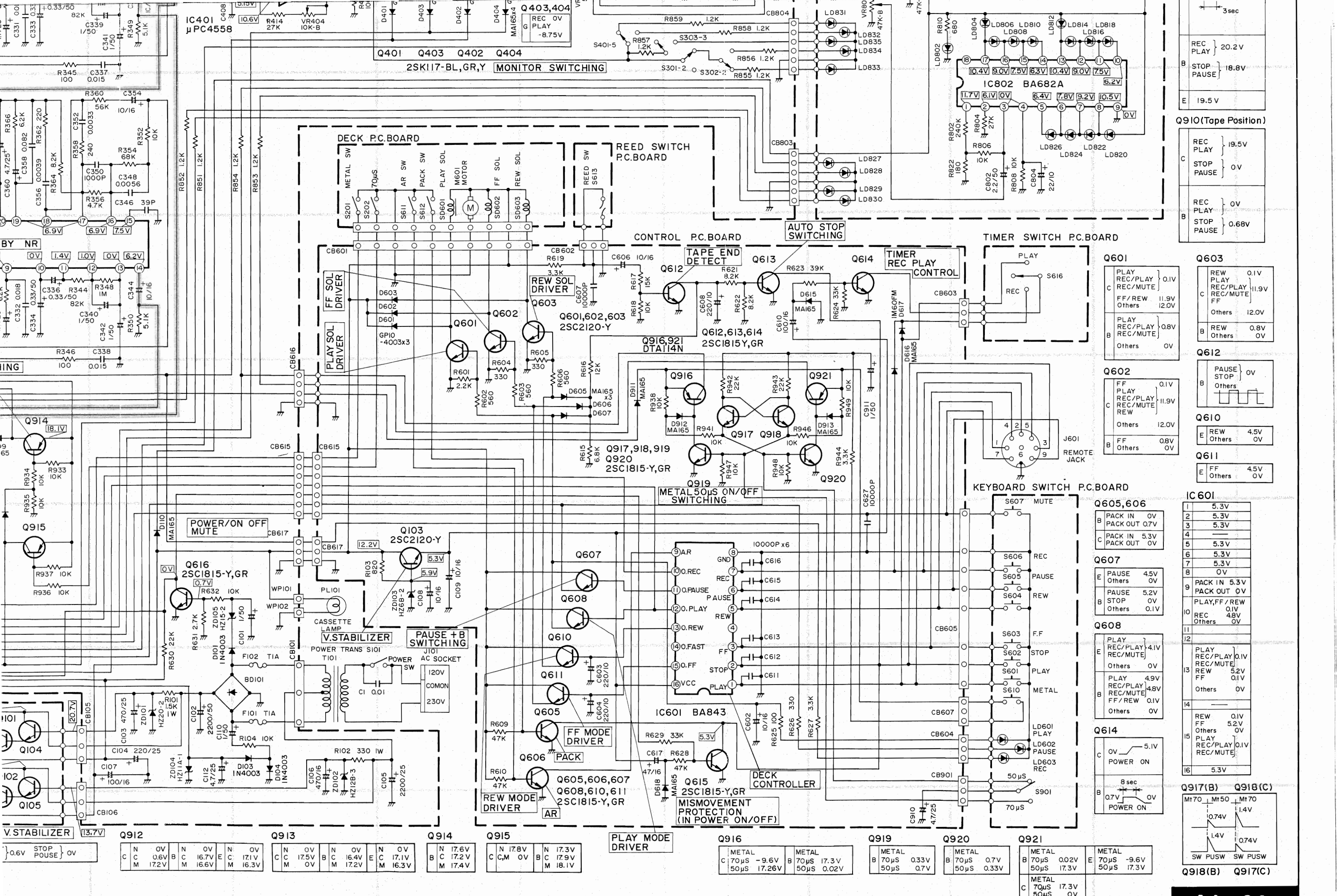

REC PLAY	20.2V
STOP PAUSE	18.8V
	19.5V

REC PLAY	19.5V
STOP PAUSE	0V
REC PLAY	0V
STOP PAUSE	0.68V

PLAY REC/PLAY	0.1V
REC/MUTE	11.9V
FF/REW	11.9V
Others	12.0V
PLAY REC/PLAY	0.8V
REC/MUTE	0.8V
Others	0V

PAUSE STOP	0V
Others	12.0V

REW	4.5V
Others	0V

FF	4.5V
Others	0V

1	5.3V
2	5.3V
3	5.3V
4	5.3V
5	5.3V
6	5.3V
7	5.3V
8	0V
9	PACK IN 5.3V
	PACK OUT 0V
10	PLAY, FF / REW
	REC 0.1V
	Others 4.8V
11	0V
12	0V
13	PLAY REC/PLAY 0.1V
	REC/MUTE 0.1V
	REW 5.2V
	FF 0.1V
	Others 0V
14	0V
15	REW 0.1V
	FF 5.2V
	Others 0V
16	5.3V

PLAY REC/PLAY	4.1V
REC/MUTE	4.1V
Others	0V
PLAY REC/PLAY	4.9V
REC/MUTE	4.8V
FF/REW	0.1V
Others	0V

0V	5.1V
POWER ON	0V

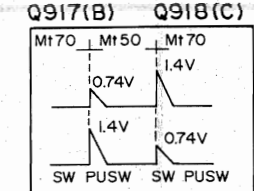

Q917(B) Q918(C)
Q918(B) Q917(C)

BA682A: IC801, 802

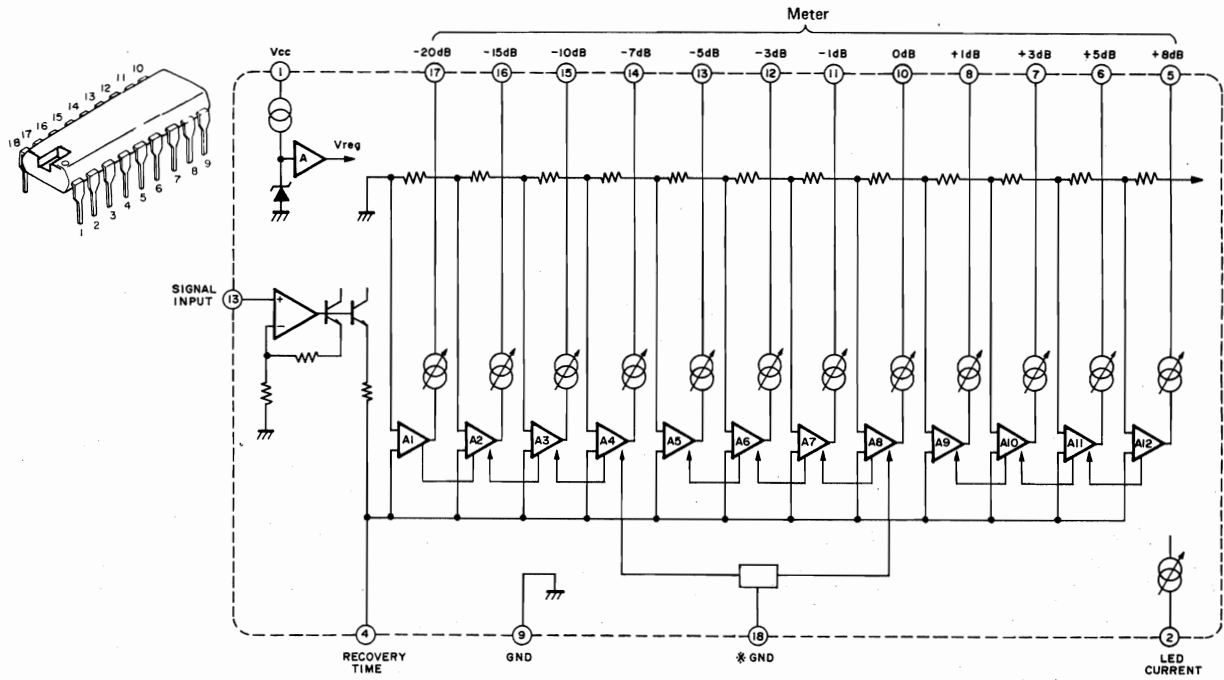

2SD1266: Q101, 102

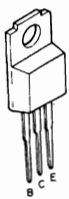

2SD1406: Q101, 102

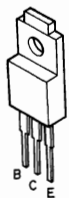

2SK127: Q401 ~ 404,
2SK128: Q507, 508

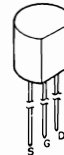

2SK301: Q507, 508
2SK117: Q401 ~ 404



2SC1815: Q104, 105, 211 ~ 214, 301 ~ 303,
2SC945: Q501 ~ 506, 513, 514, 605 ~ 608,
Q610 ~ 616, 902, 904, 905, 906, 910,
Q911, 917 ~ 920

2SC1842: Q207 ~ 210, 251, 252
2SC1843: Q405, 406, 509, 510
2SD1302: Q103, 407, 408, 515, 601 ~ 603
2SC2120: Q511, 512
2SC1890: Q901, 903, 907, 909, 912 ~ 915
2SC1980: Q901, 903, 907, 909, 912 ~ 915
2SA733: Q901, 903, 907, 909, 912 ~ 915



DTC114: Q516, 517, 908
DTA114N: Q916, 921



1. GND
2. OUT
3. IN