

Service Manual

Model: ACL2

Compressor/Limiter/Gate



www.altoproaudio.com

Version: 1.1

CONTENTS

- 1. Specification**
- 2. Block Diagram**
- 3. Schematic Diagram**
- 4. Printed Circuit Board**
- 5. Wiring Diagram**
- 6. Test Procedure**
- 7. Electrical Parts List**
- 8. Exploded Views & Mechanical Parts List**
- 9. Troubleshooting**
- 10. Notes**

SPECIFICATIONS FOR ACL2

AUDIO INPUT		
Connectors	XLR and 1/4" TRS (Pin 2 and Tip hot)	
Type	Electronically balanced/unbalanced	
Impedance	Balanced >50Kohm, Unbalanced>25Kohm	
Max input level	>+24dBu balanced and unbalanced	
CMRR	Typically>50dB at 1KHz	

AUDIO OUTPUT		
Connectors	XLR and 1/4" TRS (Pin 2 and Tip hot)	
Type	Electronically balanced/unbalanced	
Impedance	Balanced 120ohm, Unbalanced>60ohm	
Max output level	>+21dBu,+20dBm balanced and unbalanced	

SYSTEM SPECIFICATIONS		
Bandwidth	22HZ to 22KHz, +0/-0.5dB	
Frequency Response	10Hz to 30kHz,+0/-3dB	
Noise	>-90dBrA, unweighted, 22Hz to 22kHz	
THD	<0.008% Typical at +4dBu, 1kHz, unity gain <0.04% Typical at +20dBu, 1kHz, unity gain	
IMD	<0.1% Typical SMPTE	
Crosstalk	<-100dB, 22Hz to 22Khz	
Stereo Coupling	True RMS detection	

COMPRESSOR SECTION		
Type	Interactive Compressor (Interactive Knee Adaptation)	
Threshold	variable (-40dB to +20dB)	
Ratio	variable (1 to LIM)	
Manual Attack Time	variable 0.1ms to 200ms / 20dB	
Manual Release Time	variable from 50 ms to 4s / 20dB	
Auto Attack Time	Typical 15ms at 10dB, 5ms at 20dB, 3ms at 30dB	
Auto Release Time	Program dependent, typical 125dB/s	
Output level	variable (-20dB to +20dB)	

INDICATORS		
GAIN REDUCTION	12 element LED display: 1/2/4/6/9/12/15/18/21/24/27/30 dB.	
IN/OUT	1 LED for indication of IN/OUT.	
AUTO	LED indicator for each	

POWER SUPPLY		
Mains Voltages	USA/Canada U.K./Australia Europe General Export Model	~120VAC, 60Hz ~240VAC, 50Hz ~230VAC, 50Hz ~100-120VAC, ~200-240VAC, 50-60Hz
Fuse	100-120VAC :200mA (SLOW-BLOW) 200-240VAC : 100mA (SLOW-BLOW)	
Power consumption	10Watts	
Mains Connection	Standard IEC receptacle	

PHYSICAL		
Dimension	W(483.0)*D(198.0)*H(44.2) mm	
Net Weight	3Kg	

ACL2 BLOCK DIAGRAM

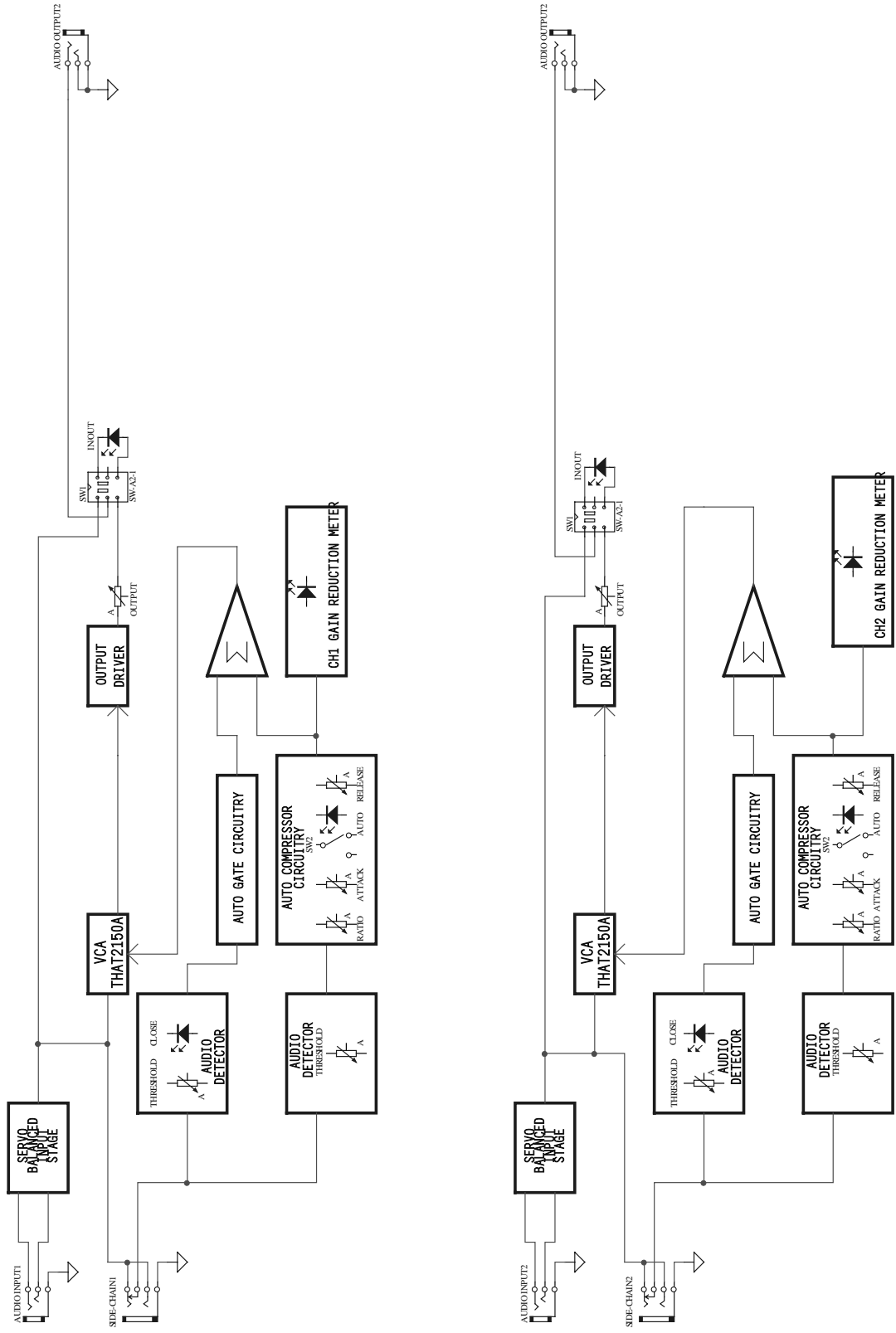

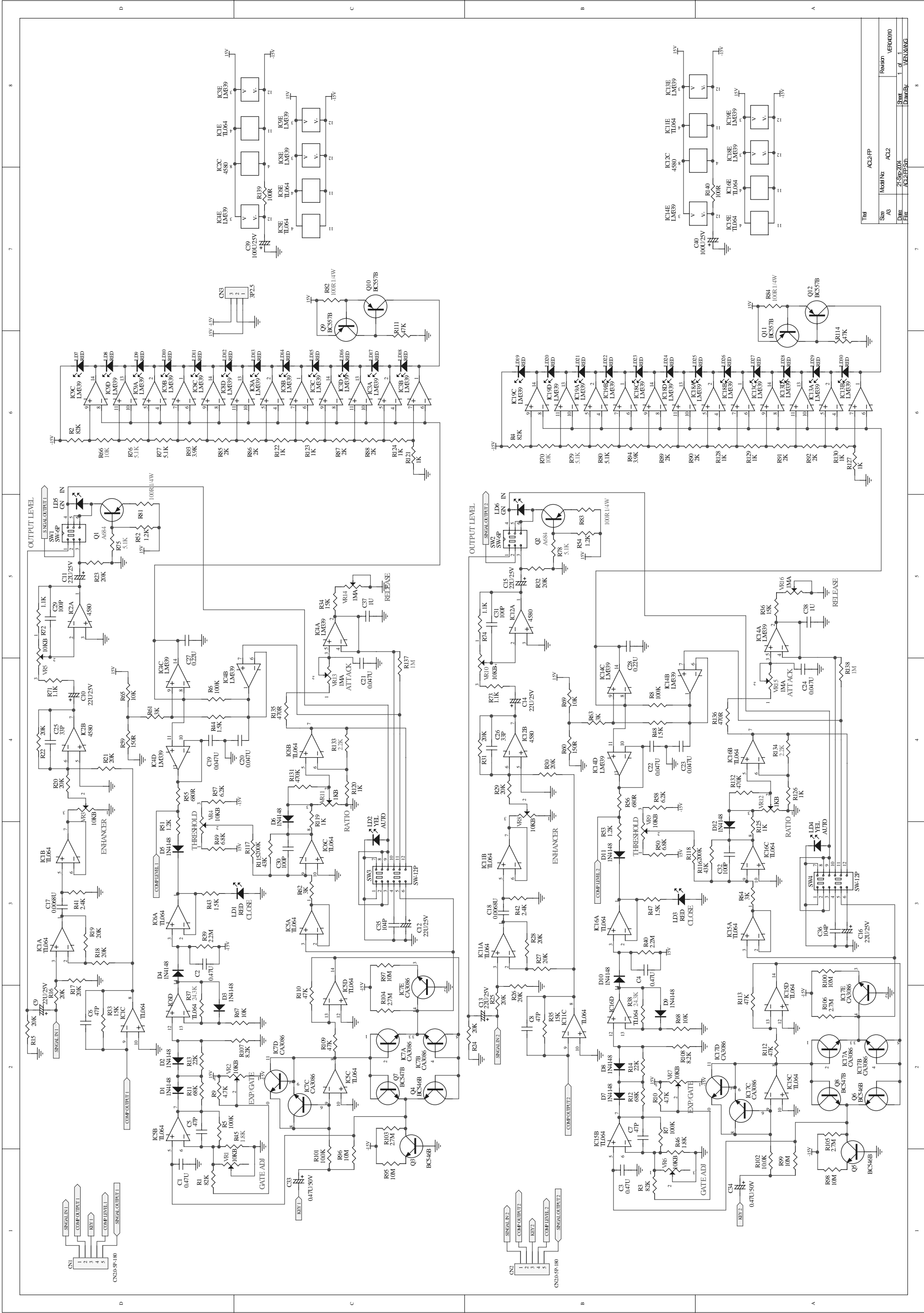

Rev	1	Drawn By	WENXIANG
Doc No	ZLSP-208	Model No	ACL2P
Part No	ACL2P-208	Mod No	ACL2P
Ver	1.0	Reason	VER00090

1	2	3	4	5	6	7	8
---	---	---	---	---	---	---	---

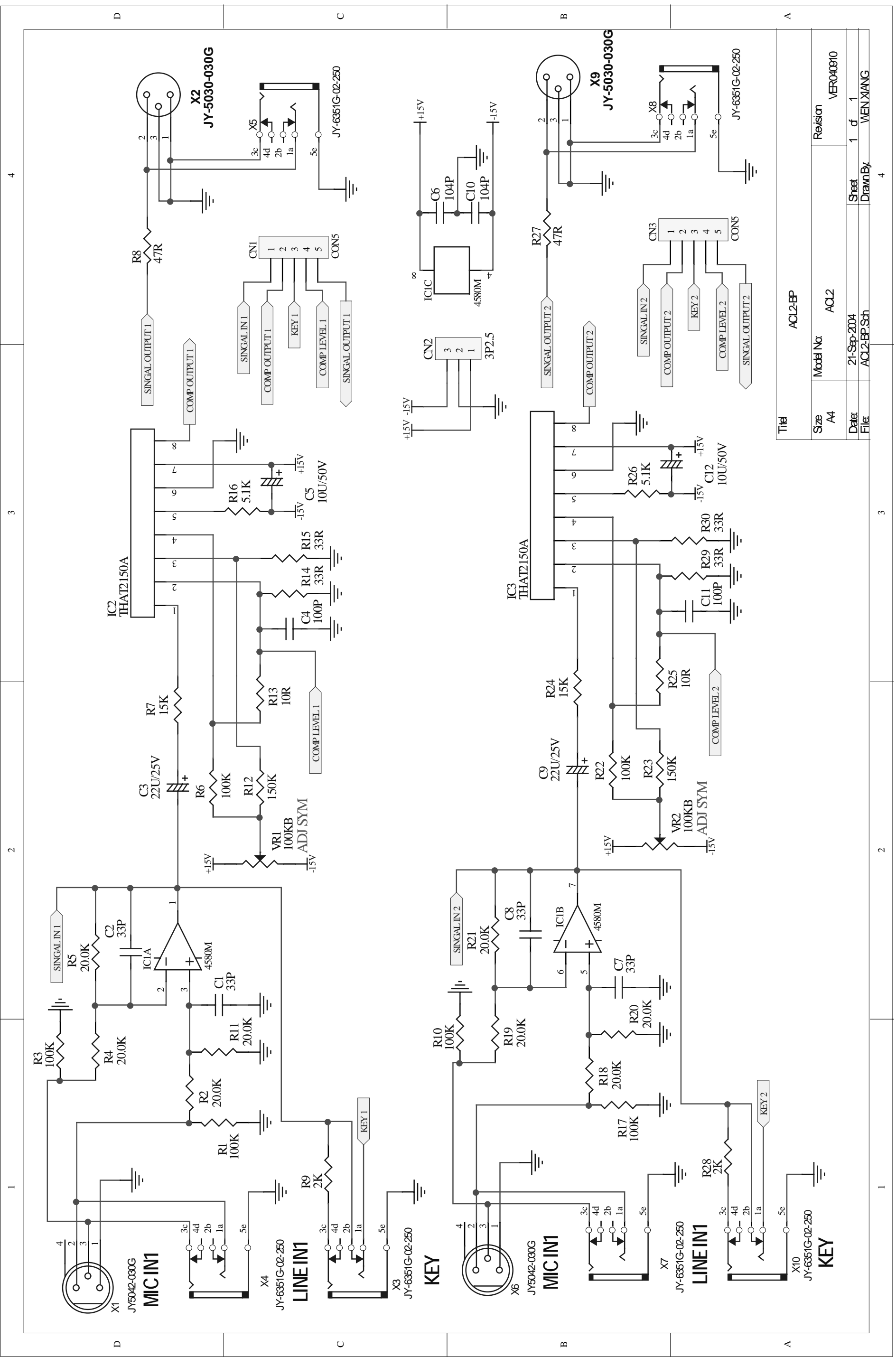

Title		ACL2-BP	
Size	A4	Model No.	ACL2
Date	21-Sep-2004	Revision	VER040910
File	ACL2-BP.Sch	Sheet	1 of 1
		DrawnBy	WENXIANG

1 2 3 4

1 2 3 4

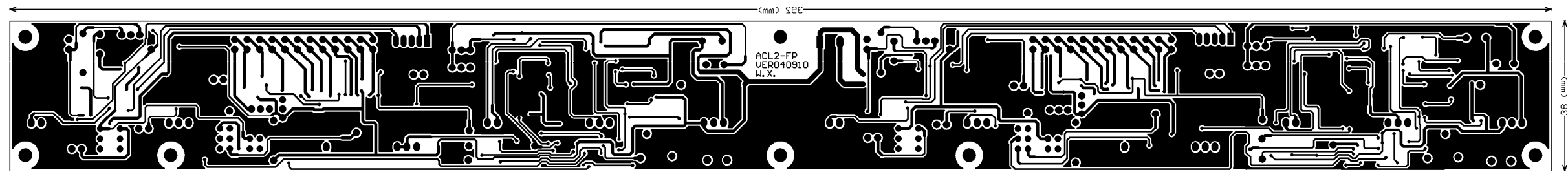

PCB : ACL2-FP Bottom Layer

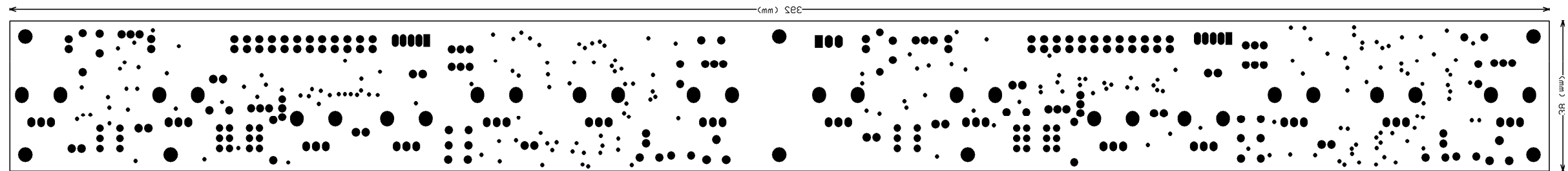

PCB : ACL2-FP Bottom Solder Mask

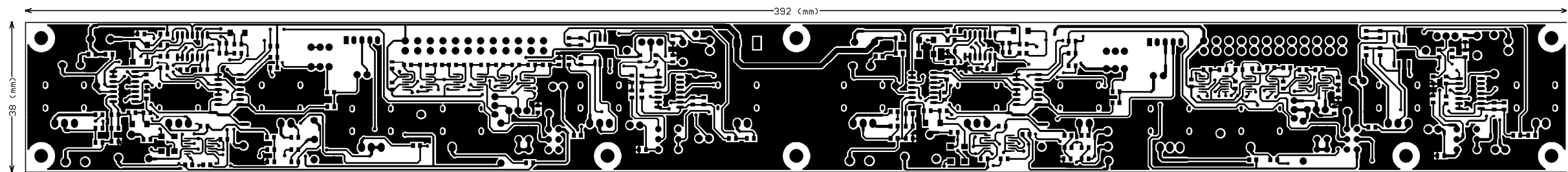

PCB : ACL2-FP TOP Layer

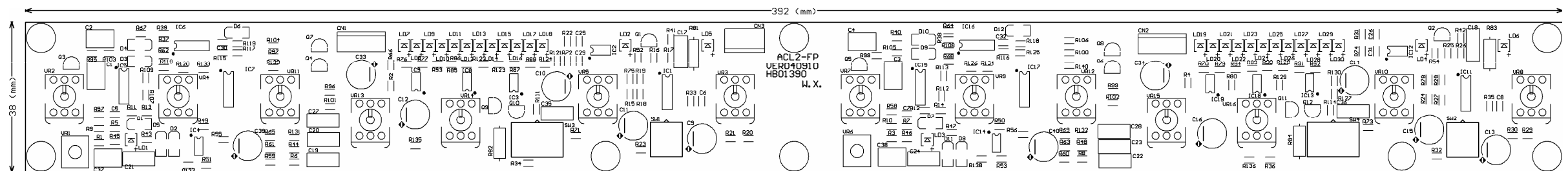

PCB : ACL2-FP Top overlay

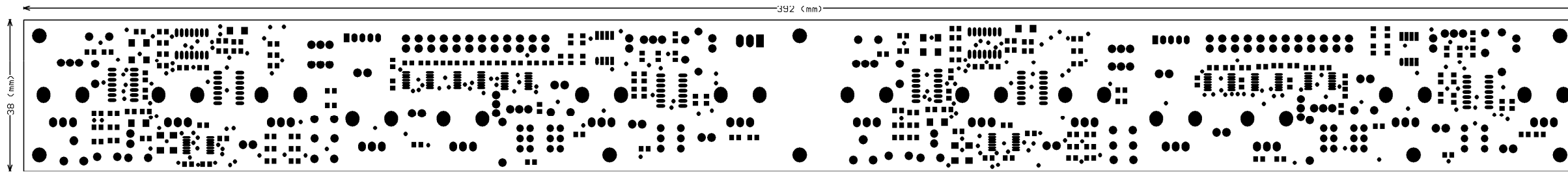

PCB : ACL2-FP TOP Solder Mask

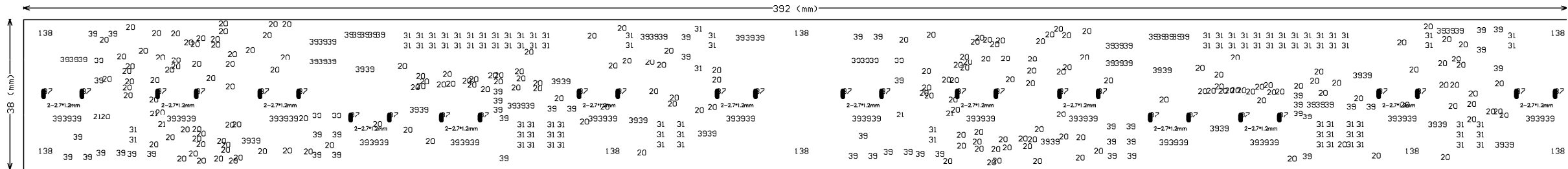

PCB : ACL2-FP Drill Drawing

T Tool	Hole Size	Hole Count	Plated	Tool Travel
T1	20mil (0.508mm)	204		57.40 Inch (1457.88 mm)
T2	21mil (0.5334mm)	5		17.98 Inch (456.78 mm)
T3	31mil (0.7874mm)	98		40.19 Inch (1020.90 mm)
T4	39mil (0.9906mm)	163		50.57 Inch (1284.45 mm)
T5	87mil (2.2098mm)	28		30.60 Inch (777.17 mm)
T6	138mil (3.5052mm)	8	NPTH	31.64 Inch (803.66 mm)
Totals		506		228.38 Inch (5800.84 mm)

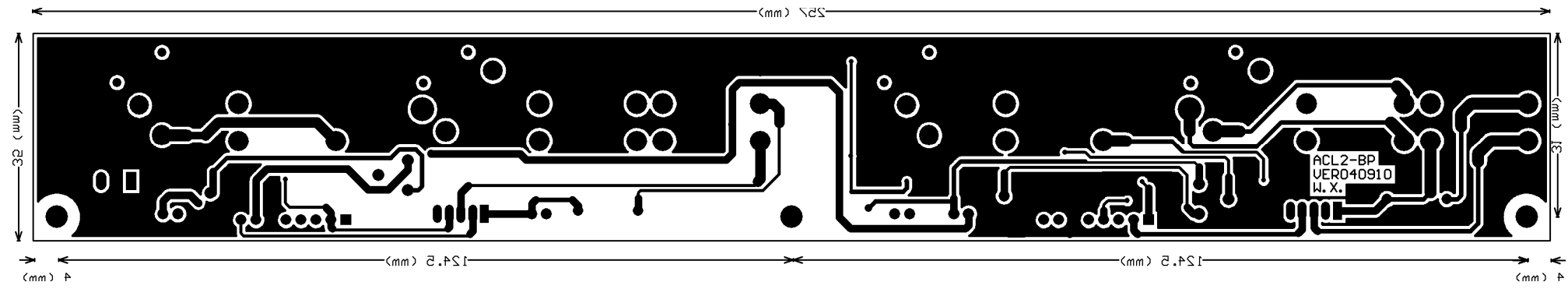

PCB · ACL2-BP Bottom Layer

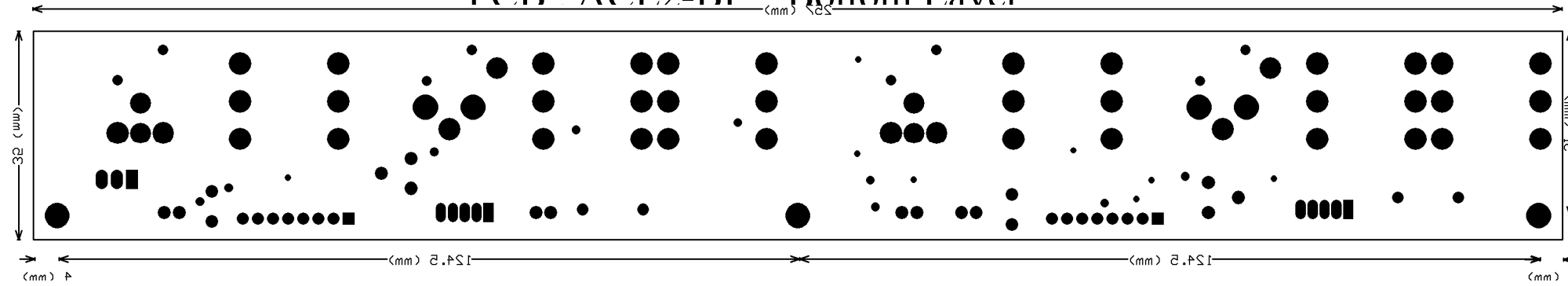

PCB : ACL2-BP Bottom Solder Mask

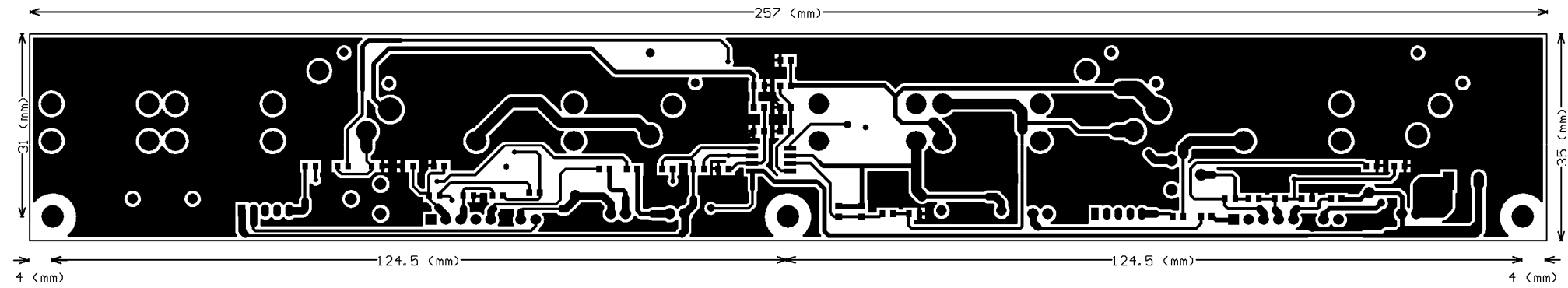

PCB : ACL2-BP TOP Layer

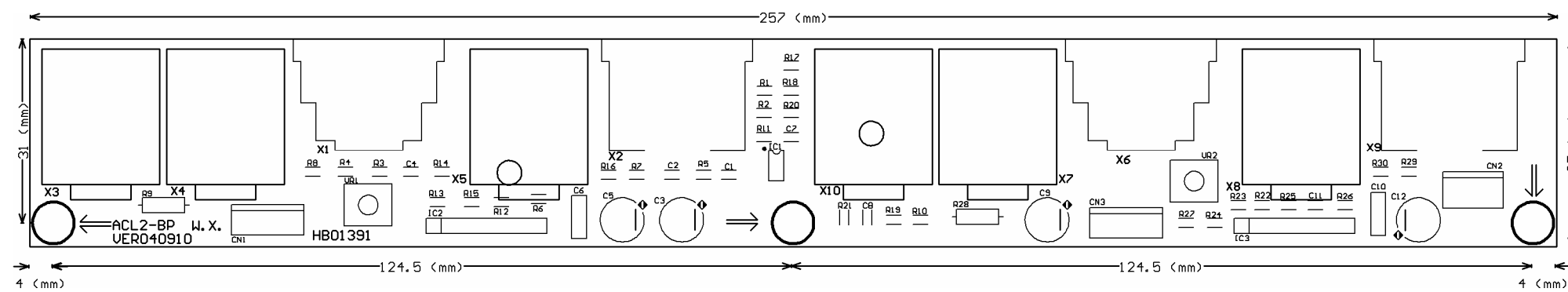

PCB : ACL2-BP Top overlay

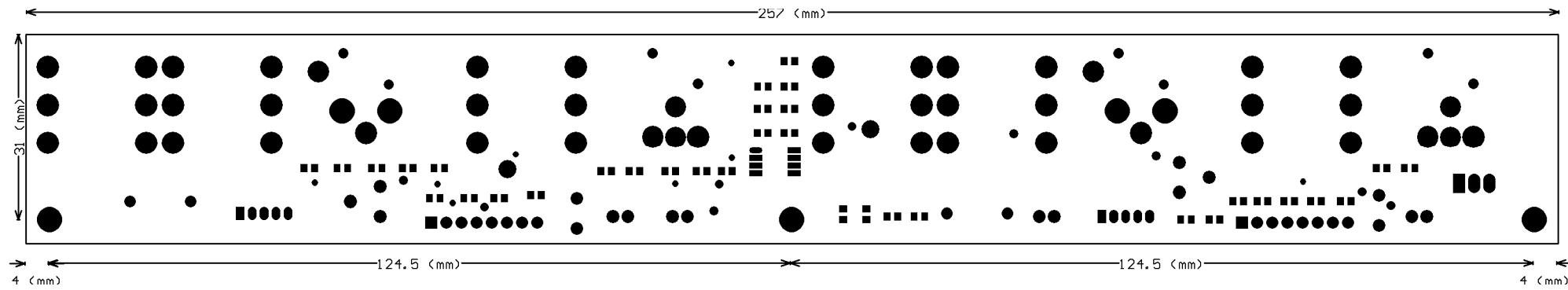

PCB : ACL2-BP TOP Solder Mask

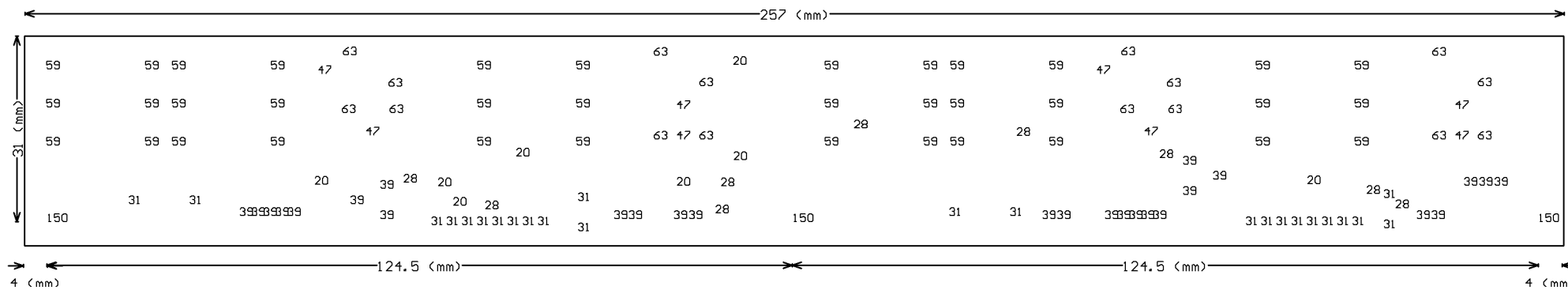

PCB : ACL2-BP Drill Drawing

T Tool	Hole Size	Hole Count	Plated	Tool Travel
T1	20mil (0.508mm)	8		9.41 Inch (239.04 mm)
T2	28mil (0.7112mm)	9		13.28 Inch (337.38 mm)
T3	31mil (0.7874mm)	24		25.45 Inch (646.37 mm)
T4	39mil (0.9906mm)	27		25.58 Inch (649.85 mm)
T5	47mil (1.1938mm)	8		10.52 Inch (267.09 mm)
T6	59mil (1.4986mm)	36		14.98 Inch (380.60 mm)
T7	63mil (1.6002mm)	12		11.26 Inch (286.09 mm)
T8	150mil (3.81mm)	3		19.77 Inch (502.03 mm)
T9	63mil (1.6002mm)	4	NPTH	9.87 Inch (250.67 mm)
Totals		131		140.12 Inch (3559.12 mm)

ACL2 全機配線圖

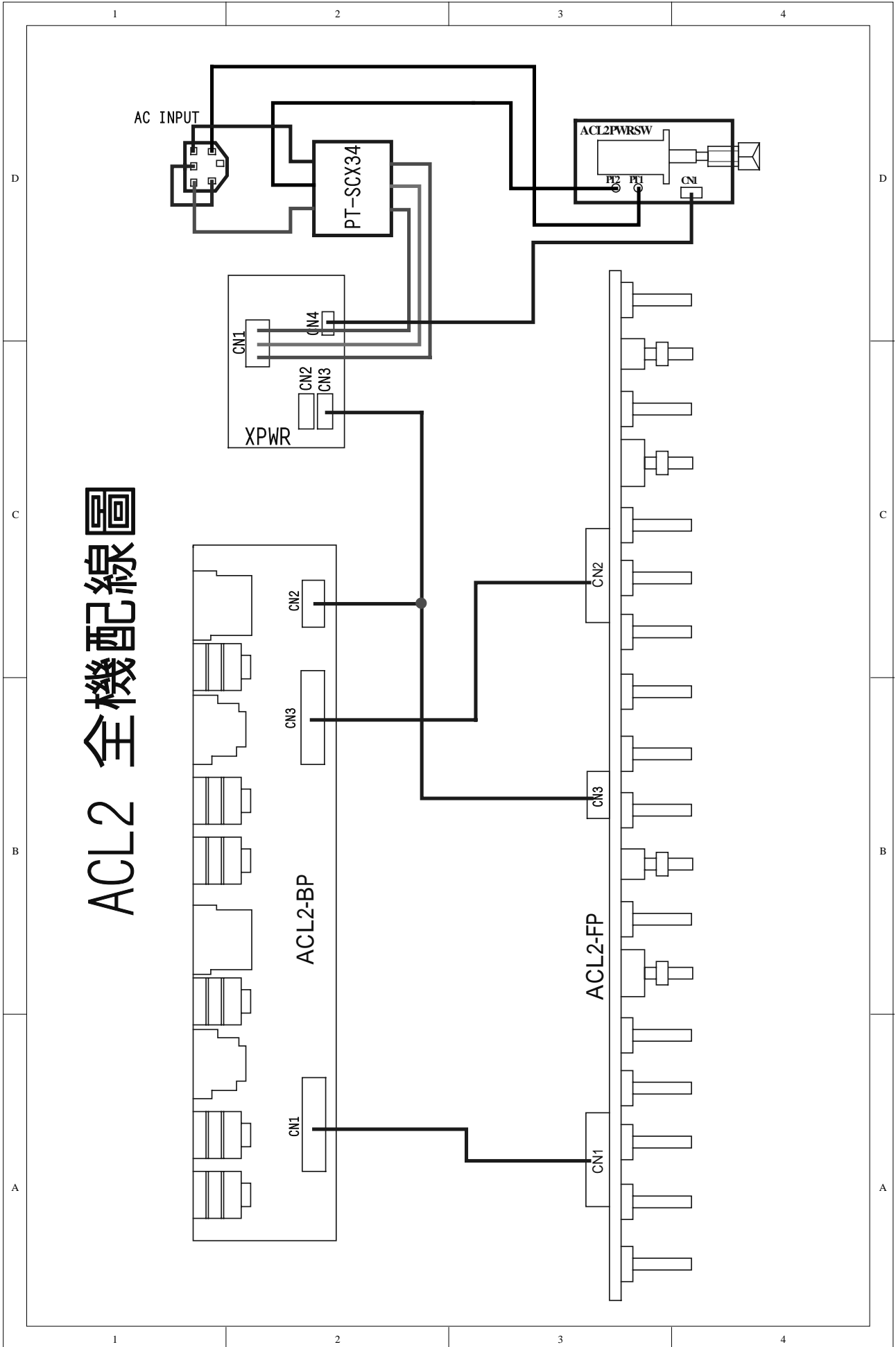

Multi-Level BOM Structure Listing

Report No.: IEBO_P02
 Prepared by 030037[蘇文祥]
 Item No. PF01980
 DESCRIPTION: ACL2
 ACL2 ALTO 230V

Version

UNIT: PCS
 Date: 2004/11/06

Date 2004/12/14
 Page No.: 1 / 13

Version	Item No	Loss %	Ver.	Unit	Cardinal	Effective Date
Component Remark	Item Descri				Usage Rate	@:Phantom Layer
					Attrition	Rate
-0001-----	MA00084 panel			PCS	1.0000	2004/11/06
	ACL2 ALTO_V1.0				1	N
					0.00	%
-0001-----	MA00206 panel			PCS	1.0000	2004/09/27
	ACL2				1	N
					0.00	%
-0001-----	MA00169 panel			PCS	1.0000	2004/09/27
	ACL2_V1.0				1	N
					0.00	%
-0001-----	MJ00057 AL board			PCS	1.0000	2004/09/27
	3*2000*1000 16.32kg			KG	84	N
					0.00	%
-0002-----	MB03703 rear board			PCS	1.0000	2004/11/06
	ACL2_V1.1				1	N
					0.00	%
-0001-----	MB03694 bottom board			PCS	1.0000	2004/09/27
	ACL2				1	N
					0.00	%
-0001-----	MB03693 bottom rear board			PCS	1.0000	2004/09/27
	ACL2_V1.0				1	N
					0.00	%
-0001-----	MJ00058 iron board			PCS	1.0000	2004/09/27
	1*2135*1220 20.45kg			KG	12	N
					0.00	%
-0002-----	ME00035 iron pillar			PCS	5.0000	2004/09/27
	hexagon6.35*M3*6				1	N
					0.00	%
-0003-----	ME00001 screw pillar			PCS	1.0000	2004/09/27
	M4*10*0.7PH				1	N
					0.00	%
-0004-----	ME00004 screw pillar			PCS	2.0000	2004/09/27
	M3*10*0.5PH				1	N
					0.00	%
-0005-----	ME00032 iron pillar			PCS	3.0000	2004/09/27
	hexagon6.35*M3*5.2				1	N
					0.00	%
-0003-----	MI02395 frint board			PCS	1.0000	2004/11/06
	ACL2_V1.0				1	N
					0.00	%
-0001-----	MJ00061 Zn-plated board			PCS	1.0000	2004/09/27
	1*2135*1220 20.45kg			KG	115	N
					0.00	%
-0002-----	ME00035 iron pillar			PCS	8.0000	2004/09/27
	hexagon6.35*M3*6				1	N
					0.00	%
-0004-----	MC00649 top cover			PCS	1.0000	2004/11/06
	ACL2_V1.0				1	N
					0.00	%
-0001-----	MC00633 top cover			PCS	1.0000	2004/11/12
	ACL2				1	N
					0.00	%
-0001-----	MC00632 top cover			PCS	1.0000	2004/09/27
	ACL2_V1.0				1	N
					0.00	%
-0001-----	MJ00059 iron board			PCS	1.0000	2004/09/27
	1.2*2135*1220 24.54kg			KG	24	N
					0.00	%
-0005-----	NI01862 key			PCS	4.0000	2004/11/06
	5.5*5.5*14.5				1	N
					0.00	%
-0006-----	NI02925 knob			PCS	4.0000	2004/11/06
	5.5*5.5*11.2mm TYPHOON black				1	N
					0.00	%
-0007-----	NI03256 knob			PCS	10.0000	2004/11/21
	φ9.5*22.75 5445C_V1.0				1	N
					0.00	%

Multi-Level BOM Structure Listing

Report No.: IEBO_P02
 Prepared by 030037[蘇文祥]
 Item No. PF01980
 DESCRIPTION: ACL2
 ACL2 ALTO 230V

Version

UNIT: PCS
 Date: 2004/11/06

Date 2004/12/14
 Page No.: 2 / 13

Version	Item No Item Descri	Loss %	Ver.	Unit	Cardinal Usage Rate Attrition	Effective Date @:Phantom Layer Rate
-0008-----	NI03257 knob φ11.5*25 5445C_V1.0			PCS	4.0000 1 0.00 %	2004/11/21 N
-0009-----	NI03258 knob φ7.5*3.3 298C_V1.0			PCS	10.0000 1 0.00 %	2004/11/21 N
-0010-----	NI03259 knob φ9.2*4.1 298C_V1.0			PCS	4.0000 1 0.00 %	2004/11/21 N
-0011-----	HC00015 AC socket (S)315-B (AC select)			PCS	1.0000 1 0.00 %	2004/11/06 N
-0012-----	HD00023 glass tube fuse 200mA 250V φ5.2*20mm CSA/S/UL/VDE			PCS	1.0000 1 0.00 %	2004/11/06 N
-0013-----	NI03251 knob 19.3*19.2*7_V1.0			PCS	1.0000 1 0.00 %	2004/11/06 N
-0014-----	NI03252 switch key 32*12.53*14_V1.0			PCS	1.0000 1 0.00 %	2004/11/06 N
-0015-----	NI03253 bole 15*15*10.7_V1.0			PCS	1.0000 1 0.00 %	2004/11/06 N
-0016-----	MG00025 screw M3*6			PCS	3.0000 1 0.00 %	2004/11/06 N
-0017-----	MG00038 screw M3*6			PCS	7.0000 1 0.00 %	2004/11/06 N
-0018-----	MG00042 screw M3*10			PCS	2.0000 1 0.00 %	2004/11/06 N
-0019-----	MG00538 screw M3*10*0.5PH_V1.0			PCS	4.0000 1 0.00 %	2004/11/06 N
-0020-----	MF00038 washer φ4*φ7*1t			PCS	1.0000 1 0.00 %	2004/11/06 N
-0021-----	ME00015 nut 3m/m			PCS	2.0000 1 0.00 %	2004/11/06 N
-0022-----	MG00061 screw M3*10			PCS	8.0000 1 0.00 %	2004/11/06 N
-0023-----	MG00041 screw M3*6			PCS	11.0000 1 0.00 %	2004/11/06 N
-0024-----	ME00016 nut 4m/m			PCS	1.0000 1 0.00 %	2004/11/06 N
-0025-----	NI00002 nut of plastic φ7/16"*G20/15*4.8(hexagon)			PCS	6.0000 1 0.00 %	2004/11/06 N
-0026-----	NC00131 washer 1*φ11.3*φ15.3 red			PCS	12.0000 1 0.00 %	2004/11/06 N
-0027-----	MF00048 washer φ4*φ8*0.5t			PCS	2.0000 1 0.00 %	2004/11/06 N
-0028-----	MG00281 screw M3*6			PCS	2.0000 1 0.00 %	2004/11/06 N
-0029-----	MG00560 copper pillar M3*24.5*0.5PH 30.5			PCS	2.0000 1 0.00 %	2004/11/06 N

Multi-Level BOM Structure Listing

Report No.: IEBO_P02
 Prepared by 030037[蘇文祥]
 Item No. PF01980
 DESCRIPTION: ACL2
 ACL2 ALTO 230V

Version

UNIT: PCS
 Date: 2004/11/06

Date 2004/12/14
 Page No.: 3 / 13

Version	Item No Item Descri	Loss %	Ver.	Unit	Cardinal Usage Rate Attrition	Effective Date @:Phantom Layer Rate
-0030-----	MG00036 screw M3*4			PCS	3.0000 1 0.00 %	2004/11/06 N
-0031-----	MF00037 washer φ 3* φ 5*1t			PCS	2.0000 1 0.00 %	2004/11/21 N
-0032-----	HA01468 header wiring 2P-2P 300			PCS	1.0000 1 0.00 %	2004/11/06 N
-0033-----	HA01558 row-wire connector wiring 5P-5P 220			PCS	2.0000 1 0.00 %	2004/11/06 N
-0034-----	HA02905 wire 3P-3P/3P 330/200mm UL1007 24AWG			PCS	1.0000 1 0.00 %	2004/11/06 N
-0035-----	HA00861 power cord Europe 3P LT-312+LT-501			PCS	1.0000 1 0.00 %	2004/11/06 N
-0036-----	NI00252 sleeve φ 4*20mm			PCS	6.0000 1 0.00 %	2004/11/06 N
-0001-----	NI00248 sleeve φ 4*1000mm			M	20.0000 1000 0.00 %	2002/06/04 N
-0037-----	NI00218 cable tie-black ALT-102SB			PCS	3.0000 1 0.00 %	2004/11/06 N
-0038-----	NI00501 foot cushion 12.7*9*3t(SF-004)			PCS	4.0000 1 0.00 %	2004/11/06 N
-0039-----	NA00137 clip-chain bag 5*7			PCS	1.0000 1 0.00 %	2004/11/06 N
-0040-----	NF00061 assurance card ALTO			PCS	1.0000 1 0.00 %	2004/11/06 N
-0041-----	NA00279 clip-chain bag 0.04t*100*150mm_V1.0			PCS	1.0000 1 0.00 %	2004/11/06 N
-0042-----	AD00011 twin adhesive 90*120mm_V1.0			PCS	1.0000 1 0.00 %	2004/11/06 N
-0043-----	HJ00006 desiccant 30g			PCS	1.0000 1 0.00 %	2004/11/06 N
-0044-----	NB03221 colour box ACL2 ALTO_V1.0			PCS	1.0000 1 0.00 %	2004/11/06 N
-0045-----	NB02163 barrier X23,34,40			PCS	1.0000 1 0.00 %	2004/11/06 N
-0046-----	NB02164 barrier X23,34,40			PCS	1.0000 1 0.00 %	2004/11/06 N
-0047-----	NB02088 box (1H) ALTO 19"			PCS	1.0000 4 0.00 %	2004/11/06 N
-0048-----	TC00074 transformer PT-SCX34			PCS	1.0000 1 0.00 %	2004/11/06 N
-0049-----	NE13576 label ACL2_V1.0			PCS	4.0000 1 0.00 %	2004/11/06 N
-0001-----	NH00012 bond paper 0.04*1M			M	1.0000 80 0.00 %	2004/09/27 N

Multi-Level BOM Structure Listing

Report No.: IEBO_P02
 Prepared by 030037[蘇文祥]
 Item No. PF01980
 DESCRIPTION: ACL2
 ACL2 ALTO 230V

Version

UNIT: PCS
 Date: 2004/11/06

Date 2004/12/14
 Page No.: 4 / 13

Version	Item No Item Descri	Loss %	Ver.	Unit	Cardinal Usage Rate Attrition	Effective Date @:Phantom Layer Rate
0002-----	NI00014 membrane 0.035*1M			M	1.0000 80 0.00 %	2004/09/27 N
0050-----	NE05004 label ALTO			PCS	4.0000 1 0.00 %	2004/11/06 N
0001-----	NH00334 cone paper 0.040*1m			M	1.0000 76 0.00 %	2004/11/29 N
0051-----	HK04586 PC board P-ACL2-FP-DIP			PCS	1.0000 1 0.00 %	2004/11/06 N
0001-----	RC00155 resistor 10KΩ φ6 EVND8A VR1,VR6			PCS	2.0000 1 0.00 %	2004/11/06 N
0002-----	SA00240 L.E.D 3*3(L-714GDT) LD5,LD6			PCS	2.0000 1 0.00 %	2004/11/06 N
0003-----	SA00241 L.E.D 3*3(L-714YD) LD2,LD4			PCS	2.0000 1 0.00 %	2004/11/06 N
0004-----	SA00242 L.E.D 3*3(L-714YD) LD1,LD3,LD7,LD8,LD9,LD10,LD11,LD12,LD13,LD14,LD15, LD16,LD17,LD18,LD19,LD20,LD21,LD22,LD23,LD24,LD25, LD26,LD27,LD28,LD29,LD30			PCS	26.0000 1 0.00 %	2004/11/06 N
0005-----	NI03261 separating 38.4*22.5*2.9_V1.0 LD1,LD2,LD3,LD4,LD5,LD6,LD7,LD8,LD9,LD10,LD11,LD12, LD13,LD14,LD15,LD16,LD17,LD18,LD19,LD20,LD21,LD22, LD23,LD24,LD25,LD26,LD27,LD28,LD29,LD30			PCS	3.0000 1 0.00 %	2004/11/06 N
0006-----	RC00214 potentiometer B1KΩ R0911NOB-V1B102FN00-00 VR11,VR12			PCS	2.0000 1 0.00 %	2004/11/06 N
0007-----	RC00313 potentiometer A10KΩ 35mm R0911NOB-V1A105FN00-00 VR13,VR14,VR15,VR16			PCS	4.0000 1 0.00 %	2004/11/06 N
0008-----	RC00213 potentiometer B10KΩ 軸長35 R0911NOB-V1B103FN00-00 VR2,VR3,VR4,VR5,VR7,VR8,VR9,VR10			PCS	8.0000 1 0.00 %	2004/11/06 N
0009-----	SB00075 transistor 2SA06840R/(PANASONIC) Q1,Q2			PCS	2.0000 1 0.00 %	2004/11/06 N
0010-----	HI00162 push-button switch 2 paragraphs 6p PS-22E8552L			PCS	2.0000 1 0.00 %	2004/11/06 N

Multi-Level BOM Structure Listing

Report No.: IEBO_P02
 Prepared by 030037[蘇文祥]
 Item No. PF01980
 DESCRIPTION: ACL2
 ACL2 ALTO 230V

Version

UNIT: PCS
 Date: 2004/11/06

Date 2004/12/14
 Page No.: 5 / 13

Version	Item No	Loss %	Ver.	Unit	Cardinal	Effective Date
Component Remark	Item Descri				Usage Rate	@:Phantom Layer
					Attrition	Rate
	SW1,SW2					
-0011-----	HI00163 push-button switch 2 stage 12P PS-42E85 SW3,SW4			PCS	2.0000 1 0.00 %	2004/11/06 N
-0012-----	HC00077 row-wire header(male) 3P 2.5mm 180°			PCS	1.0000 1 0.00 %	2004/11/06 N
-0013-----	HC00256 row-wire header(male) 5P 2.0mm 180° CN1,CN2			PCS	2.0000 1 0.00 %	2004/11/06 N
-0014-----	HK04601 PC board P-ACL2-FP-AI			PCS	1.0000 1 0.00 %	2004/11/06 N
-0001-----	RA01112 fixed resistor 1/4W 100Ω R81,R82,R83,R84			PCS	4.0000 1 0.00 %	2004/11/06 N
-0002-----	CF00141 metal-film capacitor MSC 0.0068uF/100V 5% CASE01 C17,C18			PCS	2.0000 1 0.00 %	2004/11/06 N
-0003-----	CF00147 metal-film capacitor 0.047uF/100V 5% CASE01 C19,C20,C21,C22,C23,C24			PCS	6.0000 1 0.00 %	2004/11/06 N
-0004-----	CF00140 metal-film capacitor MSC 0.1uF/63V 5% CASE01 C35,C36			PCS	2.0000 1 0.00 %	2004/11/06 N
-0005-----	CF00038 metal-film capacitor MSC 0.22uF/63V 5% CASE02 C27,C28			PCS	2.0000 1 0.00 %	2004/11/06 N
-0006-----	CF00042 metal-film capacitor MSC 0.47uF/63V 5% CASE02 C1,C2,C3,C4			PCS	4.0000 1 0.00 %	2004/11/06 N
-0007-----	CF00142 metal-film capacitor MSC 1.0uF/63V 5% CASE07 C37,C38			PCS	2.0000 1 0.00 %	2004/11/06 N
-0008-----	CB00246 electrolytic capacitor 0.47uF/50V φ4*7mm C33,C34			PCS	2.0000 1 0.00 %	2004/11/06 N
-0009-----	CB00250 electrolytic capacitor 22uF/25V φ6*7mm C9,C10,C11,C12,C13,C14,C15,C16			PCS	8.0000 1 0.00 %	2004/11/06 N

Multi-Level BOM Structure Listing

Report No.: IEBO_P02
 Prepared by 030037[蘇文祥]
 Item No. PF01980
 DESCRIPTION: ACL2
 ACL2 ALTO 230V

Version

UNIT: PCS
 Date: 2004/11/06

Date 2004/12/14
 Page No.: 6 / 13

Version	Item No Item Descri	Loss %	Ver.	Unit	Cardinal Usage Rate Attrition Rate	Effective Date @:Phantom Layer Rate
0010-----	CB00235 electrolytic capacitor 100uF/25V φ6*11mm C39,C40			PCS	2.0000 1 0.00 %	2004/11/06 N
0011-----	SB00068 transistor BC546B(PHILIPS) Q3,Q4,Q5,Q6			PCS	4.0000 1 0.00 %	2004/11/06 N
0012-----	SB00069 transistor BC547B,126 Q7,Q8			PCS	2.0000 1 0.00 %	2004/11/06 N
0013-----	SB00070 transistor BC557B Q9,Q10,Q11,Q12			PCS	4.0000 1 0.00 %	2004/11/06 N
0014-----	HK04587 PC board P-ACL2-FP-SMD			PCS	1.0000 1 0.00 %	2004/11/06 N
0001-----	HB01390 PCB ACL2-FP(1*2)_VER040910			PCS	1.0000 1 0.00 %	2004/11/06 N
0002-----	RD00068 SMD fixed resistor 1/10W 100Ω ±5% 0603 R139,R140			PCS	2.0000 1 0.00 %	2004/11/06 N
0003-----	RD00070 SMD fixed resistor 1/10W 150Ω ±5% 0603 R59,R60			PCS	2.0000 1 0.00 %	2004/11/06 N
0004-----	RD00078 SMD fixed resistor 1/10W 470Ω ±5% 0603 R135,R136			PCS	2.0000 1 0.00 %	2004/11/06 N
0005-----	RD00080 SMD fixed resistor 1/10W 680Ω ±5% 0603 R55,R56			PCS	2.0000 1 0.00 %	2004/11/06 N
0006-----	RD00083 SMD fixed resistor 1/10W 1.0KΩ ±5% 0603 R119,R120,R121,R122,R123,R124,R125,R126,R127,R128, R129,R130			PCS	12.0000 1 0.00 %	2004/11/06 N
0007-----	RD00350 SMD fixed resistor 1/10W 1.1KΩ ±5% 0603 R71,R72,R73,R74			PCS	4.0000 1 0.00 %	2004/11/06 N
0008-----	RD00084 SMD fixed resistor 1/10W 1.2KΩ ±5% 0603 R51,R52,R53,R54			PCS	4.0000 1 0.00 %	2004/11/06 N

Multi-Level BOM Structure Listing

Report No.: IEBO_P02
 Prepared by 030037[蘇文祥]
 Item No. PF01980
 DESCRIPTION: ACL2
 ACL2 ALTO 230V

Version

UNIT: PCS
 Date: 2004/11/06

Date 2004/12/14
 Page No.: 7 / 13

Version	Item No	Loss %	Ver.	Unit	Cardinal	Effective Date
Component Remark	Item Descri				Usage Rate	@:Phantom Layer
					Attrition	Rate
-0009-----	RD00085 SMD fixed resistor 1/10W 1.5KΩ ±5% 0603 R43,R44,R47,R48			PCS	4.0000 1 0.00 %	2004/11/06 N
-0010-----	RD00086 SMD fixed resistor 1/10W 1.8KΩ ±5% 0603 R45,R46			PCS	2.0000 1 0.00 %	2004/11/06 N
-0011-----	RD00087 SMD fixed resistor 1/10W 2.0KΩ ±5% 0603 R85,R86,R87,R88,R89,R90,R91,R92			PCS	8.0000 1 0.00 %	2004/11/06 N
-0012-----	RD00088 SMD fixed resistor 1/10W 2.2KΩ ±5% 0603 R133,R134			PCS	2.0000 1 0.00 %	2004/11/06 N
-0013-----	RD00090 SMD fixed resistor 1/10W 3.0KΩ ±5% 0603 R61,R62,R63,R64			PCS	4.0000 1 0.00 %	2004/11/06 N
-0014-----	RD00092 SMD fixed resistor 1/10W 3.9KΩ ±5% 0603 R93,R94			PCS	2.0000 1 0.00 %	2004/11/06 N
-0015-----	RD00093 SMD fixed resistor 1/10W 4.7KΩ ±5% 0603 R9,R10			PCS	2.0000 1 0.00 %	2004/11/06 N
-0016-----	RD00094 SMD fixed resistor 1/10W 5.1KΩ ±5% 0603 R75,R76,R77,R78,R79,R80			PCS	6.0000 1 0.00 %	2004/11/06 N
-0017-----	RD00096 SMD fixed resistor 1/10W 6.2KΩ ±5% 0603 R57,R58			PCS	2.0000 1 0.00 %	2004/11/06 N
-0018-----	RD00097 SMD fixed resistor 1/10W 6.8KΩ ±5% 0603 R49,R50			PCS	2.0000 1 0.00 %	2004/11/06 N
-0019-----	RD00099 SMD fixed resistor 1/10W 8.2KΩ ±5% 0603 R107,R108			PCS	2.0000 1 0.00 %	2004/11/06 N
-0020-----	RD00101 SMD fixed resistor 1/10W 10KΩ ±5% 0603 R65,R66,R67,R68,R69,R70			PCS	6.0000 1 0.00 %	2004/11/06 N
-0021-----	RD00103 SMD fixed resistor 1/10W 15KΩ ±5% 0603			PCS	4.0000 1 0.00 %	2004/11/06 N

Multi-Level BOM Structure Listing

Report No.: IEBO_P02
 Prepared by 030037[蘇文祥]
 Item No. PF01980
 DESCRIPTION: ACL2
 ACL2 ALTO 230V

Version

UNIT: PCS
 Date: 2004/11/06

Date 2004/12/14
 Page No.: 8 / 13

Version	Item No	Loss %	Ver.	Unit	Cardinal	Effective Date
Component Remark	Item Descri				Usage Rate	@:Phantom Layer
					Attrition	Rate
	R33,R34,R35,R36					
0022-----	RD00306 SMD fixed resistor 1/10W 20KΩ ±5% 0603 R15,R16,R17,R18,R19,R20,R21,R22,R23,R24,R25,R26,R27, R28,R29,R30,R31,R32			PCS	18.0000 1 0.00 %	2004/11/06 N
0023-----	RD00105 SMD fixed resistor 1/10W 22KΩ ±5% 0603 R13,R14			PCS	2.0000 1 0.00 %	2004/11/06 N
0024-----	RD00110 SMD fixed resistor 1/10W 43KΩ ±5% 0603 R115,R116			PCS	2.0000 1 0.00 %	2004/11/06 N
0025-----	RD00111 SMD fixed resistor 1/10W 47KΩ ±5% 0603 R114,R113,R112,R111,R110,R109			PCS	6.0000 1 0.00 %	2004/11/06 N
0026-----	RD00114 SMD fixed resistor 1/10W 68KΩ ±5% 0603 R11,R12			PCS	2.0000 1 0.00 %	2004/11/06 N
0027-----	RD00115 SMD fixed resistor 1/10W 82KΩ ±5% 0603 R1,R2,R3,R4			PCS	4.0000 1 0.00 %	2004/11/06 N
0028-----	RD00116 SMD fixed resistor 1/10W 100KΩ ±5% 0603 R5,R6,R7,R8			PCS	4.0000 1 0.00 %	2004/11/06 N
0029-----	RD00263 SMD fixed resistor 1/10W 200KΩ ±5% 0603 R117,R118			PCS	2.0000 1 0.00 %	2004/11/06 N
0030-----	RD00123 SMD fixed resistor 1/10W 470KΩ ±5% 0603 R131,R132			PCS	2.0000 1 0.00 %	2004/11/06 N
0031-----	RD00125 SMD fixed resistor 1/10W 1.0MΩ ±5% 0603 R137,R138			PCS	2.0000 1 0.00 %	2004/11/06 N
0032-----	RD00126 SMD fixed resistor 1/10W 2.2MΩ ±5% 0603 R39,R40			PCS	2.0000 1 0.00 %	2004/11/06 N
0033-----	RD00127 SMD fixed resistor 1/10W 2.7MΩ ±5% 0603 R103,R104,R105,R106			PCS	4.0000 1 0.00 %	2004/11/06 N

Multi-Level BOM Structure Listing

Report No.: IEBO_P02
 Prepared by 030037[蘇文祥]
 Item No. PF01980
 DESCRIPTION: ACL2
 ACL2 ALTO 230V

Version

UNIT: PCS
 Date: 2004/11/06

Date 2004/12/14
 Page No.: 9 / 13

Version	Item No Item Descri	Loss %	Ver.	Unit	Cardinal Usage Rate Attrition Rate	Effective Date @:Phantom Layer Rate
0034-----	RD00309 SMD fixed resistor 1/10W 10MΩ ±5% 0603 R95,R96,R97,R98,R99,R100			PCS	6.0000 1 0.00 %	2004/11/06 N
0035-----	RD00445 SMD precise resistor 1/10W 2.43KΩ ±1% 0603 R41,R42			PCS	2.0000 1 0.00 %	2004/11/06 N
0036-----	RD00448 SMD precise resistor 1/10W 24.3KΩ ±1% 0603 R37,R38			PCS	2.0000 1 0.00 %	2004/11/06 N
0037-----	RD00214 SMD precise resistor 1/10W 10.0KΩ ±1% 0603 R101,R102			PCS	2.0000 1 0.00 %	2004/11/06 N
0038-----	CI00053 SMD ceramic capacitor 0603 33PF/50V NPO ±5% C25,C26			PCS	2.0000 1 0.00 %	2004/11/06 N
0039-----	CI00055 SMD ceramic capacitor 0603 47PF/50V NPO ±5% C5,C6,C7,C8			PCS	4.0000 1 0.00 %	2004/11/06 N
0040-----	CI00059 SMD ceramic capacitor 0603 100PF/50V NPO ±5% C29,C30,C31,C32			PCS	4.0000 1 0.00 %	2004/11/06 N
0041-----	SE00011 SMD rectifier diode RLS4148 0.5A (LL-34) D1,D2,D3,D4,D5,D6,D7,D8,D9,D10,D11,D12			PCS	12.0000 1 0.00 %	2004/11/06 N
0042-----	SG00119 SMD integrated circuit CA3086M96 IC7,IC17			PCS	2.0000 1 0.00 %	2004/11/06 N
0043-----	SG00116 SMD integrated circuit BA1033FV E2 IC3,IC4,IC8,IC9,IC13,IC14,IC18			PCS	8.0000 1 0.00 %	2004/11/06 N
0044-----	SG00107 SMD integrated circuit TL064CDT IC1,IC5,IC6,IC11,IC15,IC16			PCS	6.0000 1 0.00 %	2004/11/06 N
0045-----	SG00122 SMD integrated circuit NJM4580M-TE3 IC2,IC12			PCS	2.0000 1 0.00 %	2004/11/06 N

Multi-Level BOM Structure Listing

Report No.: IEBO_P02
 Prepared by 030037[蘇文祥]
 Item No. PF01980
 DESCRIPTION: ACL2
 ACL2 ALTO 230V

Version

UNIT: PCS
 Date: 2004/11/06

Date 2004/12/14
 Page No.: 10 / 13

Version	Item No Item Descri	Loss %	Ver.	Unit	Cardinal Usage Rate Attrition Rate	Effective Date @:Phantom Layer Rate
0052-----	HK04588 PC board P-ACL2-BP-DIP			PCS	1.0000 1 0.00 %	2004/11/06 N
0001-----	RA00220 fixed resistor 1/4W 2.0KΩ M type R9,R28			PCS	2.0000 1 0.00 %	2004/11/06 N
0002-----	CB00025 electrolytic capacitor 10uF/50V φ6*7mm C5,C12			PCS	2.0000 1 0.00 %	2004/11/06 N
0003-----	CB00033 electrolytic capacitor 22uF/25V φ6*7mm C3,C9			PCS	2.0000 1 0.00 %	2004/11/06 N
0004-----	CA00053 ceramic capacitor 0.1uF SL C6,C10			PCS	2.0000 1 0.00 %	2004/11/06 N
0005-----	RC00185 resistor 100KΩ 3P TG625HC-104 VR1,VR2			PCS	2.0000 1 0.00 %	2004/11/06 N
0006-----	SD00015 integrated circuit THAT2150A IC2,IC3			PCS	2.0000 1 0.00 %	2004/11/06 N
0007-----	HC00112 XLR MIC jack 99M-107SP-1-2 90° PUSH X1,X6			PCS	2.0000 1 0.00 %	2004/11/06 N
0008-----	HC00111 XLR MIC jack 99M-108SP1 X2,X9			PCS	2.0000 1 0.00 %	2004/11/06 N
0009-----	HC00108 stereo MIC jack φ6.3 stereo LJB0661-6 X3,X4,X5,X7,X8,X10			PCS	6.0000 1 0.00 %	2004/11/06 N
0010-----	HC00077 row-wire header(male) 3P 2.5mm 180° CN2			PCS	1.0000 1 0.00 %	2004/11/06 N
0011-----	HC00256 row-wire header(male) 5P 2.0mm 180° CN1,CN3			PCS	2.0000 1 0.00 %	2004/11/06 N
0012-----	HK04589 PC board P-ACL2-BP-SMD			PCS	1.0000 1 0.00 %	2004/11/06 N

Multi-Level BOM Structure Listing

Report No.: IEBO_P02
 Prepared by 030037[蘇文祥]
 Item No. PF01980
 DESCRIPTION: ACL2
 ACL2 ALTO 230V

Version

UNIT: PCS
 Date: 2004/11/06

Date 2004/12/14
 Page No.: 11 / 13

Version	Item No Item Descri	Loss %	Ver.	Unit	Cardinal Usage Rate Attrition Rate	Effective Date @:Phantom Layer Rate
0001-----	HB01391 PCB ACL2-BP(1*2)_VER040910			PCS	1.0000 1 0.00 %	2004/11/06 N
0002-----	RD00061 SMD fixed resistor 1/10W 10Ω ±5% 0603 R13,R25			PCS	2.0000 1 0.00 %	2004/11/06 N
0003-----	RD00304 SMD fixed resistor 1/10W 33Ω ±5% 0603 R14,R15,R29,R30			PCS	4.0000 1 0.00 %	2004/11/06 N
0004-----	RD00065 SMD fixed resistor 1/10W 47Ω ±5% 0603 R8,R27			PCS	2.0000 1 0.00 %	2004/11/06 N
0005-----	RD00094 SMD fixed resistor 1/10W 5.1KΩ ±5% 0603 R16,R26			PCS	2.0000 1 0.00 %	2004/11/06 N
0006-----	RD00103 SMD fixed resistor 1/10W 15KΩ ±5% 0603 R7,R24			PCS	2.0000 1 0.00 %	2004/11/06 N
0007-----	RD00116 SMD fixed resistor 1/10W 100KΩ ±5% 0603 R1,R3,R6,R10,R17,R22			PCS	6.0000 1 0.00 %	2004/11/06 N
0008-----	RD00118 SMD fixed resistor 1/10W 150KΩ ±5% 0603 R12,R23			PCS	2.0000 1 0.00 %	2004/11/06 N
0009-----	RD00219 SMD precise resistor 1/10W 20.0KΩ ±1% 0603 R2,R4,R5,R11,R18,R19,R20,R21			PCS	8.0000 1 0.00 %	2004/11/06 N
0010-----	CI00053 SMD ceramic capacitor 0603 33PF/50V NPO ±5% C1,C2,C7,C8			PCS	4.0000 1 0.00 %	2004/11/06 N
0011-----	CI00059 SMD ceramic capacitor 0603 100PF/50V NPO ±5% C4,C11			PCS	2.0000 1 0.00 %	2004/11/06 N
0012-----	SG00122 SMD integrated circuit NJM4580M-TE3 IC1			PCS	1.0000 1 0.00 %	2004/11/06 N
0053-----	HK04612 PC board P-XPWR(ACL2)			PCS	1.0000 1 0.00 %	2004/11/06 N

Multi-Level BOM Structure Listing

Report No.: IEBO_P02
 Prepared by 030037[蘇文祥]
 Item No. PF01980
 DESCRIPTION: ACL2
 ACL2 ALTO 230V

Version

UNIT: PCS
 Date: 2004/11/06

Date 2004/12/14
 Page No.: 12 / 13

Version	Item No	Loss %	Ver.	Unit	Cardinal	Effective Date
Component Remark	Item Descri				Usage Rate	@:Phantom Layer
					Attrition Rate	Rate
-0001-----	HB00012 PCB XPWR(1*4)			PCS	1.0000 1 0.00 %	2004/11/06 N
-0002-----	RA00358 fixed resistor 1/8W 1.5KΩ M type R1			PCS	1.0000 1 0.00 %	2004/12/02 N
-0003-----	CA00052 ceramic capacitor 0.1uF SL C4,C5,C8,C9			PCS	4.0000 1 0.00 %	2004/11/06 N
-0004-----	CB00065 electrolytic capacitor 470uF/25V φ 10*16mm C6,C7			PCS	2.0000 1 0.00 %	2004/11/06 N
-0005-----	CB00076 electrolytic capacitor 2200uF/35V φ 16*31mm C18,C19			PCS	2.0000 1 0.00 %	2004/11/06 N
-0006-----	SA00001 bridge rectifier 1A/400V RB154 DB1			PCS	1.0000 1 0.00 %	2004/11/06 N
-0007-----	SD00077 integrated circuit L7815CV(TO-220)(ST) IC1			PCS	1.0000 1 0.00 %	2004/11/06 N
-0008-----	SD00079 integrated circuit L7915CV(TO-220)(ST) IC2			PCS	1.0000 1 0.00 %	2004/11/06 N
-0009-----	HC00077 row-wire header(male) 3P 2.5mm 180° CN2,CN3			PCS	2.0000 1 0.00 %	2004/11/06 N
-0010-----	HC00076 row-wire header(male) 2P 2.5mm 180° CN4			PCS	1.0000 1 0.00 %	2004/11/06 N
-0011-----	HC00172 row-wire header(male) 3P 3.96mm 180° CN1			PCS	1.0000 1 0.00 %	2004/11/06 N
-0012-----	NC00005 silicone insulator TO-220 square type			PCS	2.0000 1 0.00 %	2004/11/06 N
-0013-----	MI00177 heat sink MA103*25m/m*2PIN			PCS	2.0000 1 0.00 %	2004/11/06 N
-0014-----	MF00037 washer φ 3* φ 5*1t			PCS	2.0000 1 0.00 %	2004/11/06 N

Multi-Level BOM Structure Listing

Report No.: IEBO_P02
 Prepared by 030037[蘇文祥]
 Item No. PF01980
 DESCRIPTION: ACL2
 ACL2 ALTO 230V

Version

UNIT: PCS
 Date: 2004/11/06

Date 2004/12/14
 Page No.: 13 / 13

Version	Item No Item Descri	Loss %	Ver.	Unit	Cardinal Usage Rate Attrition Rate	Effective Date @:Phantom Layer Rate
0015-----	MG00160 screw M3*6 P0.5			PCS	2.0000 1 0.00 %	2004/11/06 N
0054-----	HK04585 PC board P-ACL2PWRSW			PCS	1.0000 1 0.00 %	2004/11/06 N
0001-----	HB01389 PCB ACL2PWRSW(1*10)_VER041122			PCS	1.0000 1 0.00 %	2004/11/06 N
0002-----	HI00023 power switch SDDL B 1007U SW1			PCS	1.0000 1 0.00 %	2004/11/06 N
0003-----	SA00185 diode φ3 blue (6554-TLHB4400) LD1			PCS	1.0000 1 0.00 %	2004/12/02 N
0004-----	HC00076 row-wire header(male) 2P 2.5mm 180° CN1			PCS	1.0000 1 0.00 %	2004/11/06 N
0005-----	HA01798 wire 250 black			PCS	1.0000 1 0.00 %	2004/11/06 N
0006-----	HA01925 jumper wire 10mm R1			PCS	1.0000 1 0.00 %	2004/11/06 N
0001-----	HA02249 wire φ0.6			M KG	0.0200 1 0.00 %	2004/08/05 N
0055-----	NF01958 instruction ACL2 ALTO_V1.0			PCS	1.0000 1 0.00 %	2004/11/06 N
0001-----	NH00149 paper 889*640mm			張 令	0.6250 1 0.00 %	2004/11/12 Y
0056-----	MF00030 washer φ3*φ8*0.8t			PCS	2.0000 1 0.00 %	2004/11/23
0057-----	NA00123 PE bag 0.04t*580*300mm			PCS KG	1.0000 1 0.00 %	2004/12/03

