

Service Manual

Model: APM200



www.altoproaudio.com

Version: 1.0

CONTENT

1. INTRODUCTION.....	1
2. TECHNICAL SPECIFICATION.....	2
3. BLOCK DIAGRAM & SCHEMATIC DIAGRAM.....	4
4. PCB LAYOUT	17
5. EXPLODED VIEW & MECHANICAL PERTS LIST.....	27
6. BOM.....	30

- 16 MONO Inputs with gold plated XLR and balanced TRS JACK.
- GAIN and +48V Phantom for mono/mic inputs.
- 2 Stereo Inputs with balanced TRS Jacks.
- Peak LED in each Channels.
- 3-band EQ with sweepable MID on mono inputs.
- 4-band EQ on stereo inputs.
- 24-bit internal DSP with 256 effects, 16 preset by 16 variations With DSP
mute switch and peak LED.
- Graphic Equalizer : 9 band (63, 125, 250, 500, 1k, 2k, 4k, 8k 16k Hz)
- BNC socket for connecting gooseneck lamps .
- Low cut filters-75Hz, 18 dB/OCT on mono inputs.
- Low pass filter on mono output(80~120Hz)
- 4 AUX sends (AUX 1,2 pre/post, AUX 3,4 post)
- Foot switch digital effect on/off .
- Highly accurate 12 segment Bar graph Meters.
- Maximum Output Power :
750W+750W/4ohms.(1500W bridge /8ohms)
500W+500W/4ohms.(1000W bridge /8ohms)
- Performance and excellent noise figures.
- Manufactured under ISO9001 certified management system.

8. TECHNICAL SPECIFICATION

Mono input channels

Microphone input	electronically balanced, discrete input configuration	
Frequency response	10Hz to 55kHz, +/- 3dB	
Distortion (THD & N)	0.005% at +4dBu, 1kHz	
Gain	0dB to 45dB (MIC)	
SNR (Signal to Noise Ratio)	115dB	
Line input	electronically balanced	
Frequency response	10Hz to 55kHz, +/- 3dB	
Distortion (THD & N)	0.005% at +4dBu, 1kHz	
Gain	15dBu to 30dBu	

Stereo input channels

Line input	Unbalanced	
Frequency response	10Hz to 55kHz, +/- 3dB	
Distortion (THD & N)	0.005% at +4dBu, 1kHz	

Impedances

Microphone input	1.4kOhm
Channel Insert return	2.5kOhm
All other inputs	10kOhm or greater
Tape out	1kOhm
All other output	1200hm

Mono Equalization

Hi shelving	+/- 15dB @12kHz
Mid peak/dip	+/- 15dB frequency range 100~8kHz
Low shelving	+/- 15dB @ 80Hz

Stereo Equalization

Hi shelving	+/- 15dB @12kHz
Mid peak/dip	+/- 15dB @3kHz
Mid Low peak/dip	+/- 15dB @ 500Hz
Low shelving	+/- 15dB @ 80Hz

DSP Section

A/D and D/A converters	24 bit
DSP resolution	24 bit
Type of effects	Hall, Room, Vocal & Plate REVERBS Mono & Stereo DELAY (max DELAY TIME 650ms) Chorus, Flanger & Reverb MODULATIONS REVERB+DELAY, REVERB+CHORUS, REVERB+FLANGER combinations
Presets	256
Controls	16 position PRESET Selector 16 position VARIATION selector CLIP LED MUTE SWITCH with LED indicator

Main Mix Section

Noise (bus noise)	Fader 0dB, all input channels assigned and set to UNITY gain: - 100dBr (ref.:+4dBu)
Max output	+22dBu balanced ,
AUX Sends max out	+22dBu
ST SUB OUT	+22dBu

Power supply

Main voltage	100VAC ~ 60Hz	230VAC ~ 50Hz
	120VAC ~ 60Hz	240VAC ~ 50Hz

Power Consumption

C D	Stereo mode: 2x500W @ 4ohm(EIAJ)	2x340W @ 4ohm(RMS)
	Bridge mode: 1000W @ 8ohm(EIAJ)	
A B	Stereo mode: 2x750W @ 4ohm(EIAJ)	2x520W @ 4ohm(RMS)
	Bridge mode: 1500W @ 8ohm(EIAJ)	

8. TECHNICAL SPECIFICATION

Fuse	115V : 12A 230V : 6.3A
------	---------------------------

Physical

Dimension (WxDxH)	710x565x145mm
Weight	(Net) : 16.3kg (35.9lb) (Gross) : 21.8kg (48.6lb)

APM200 BLOCK DIAGRAM

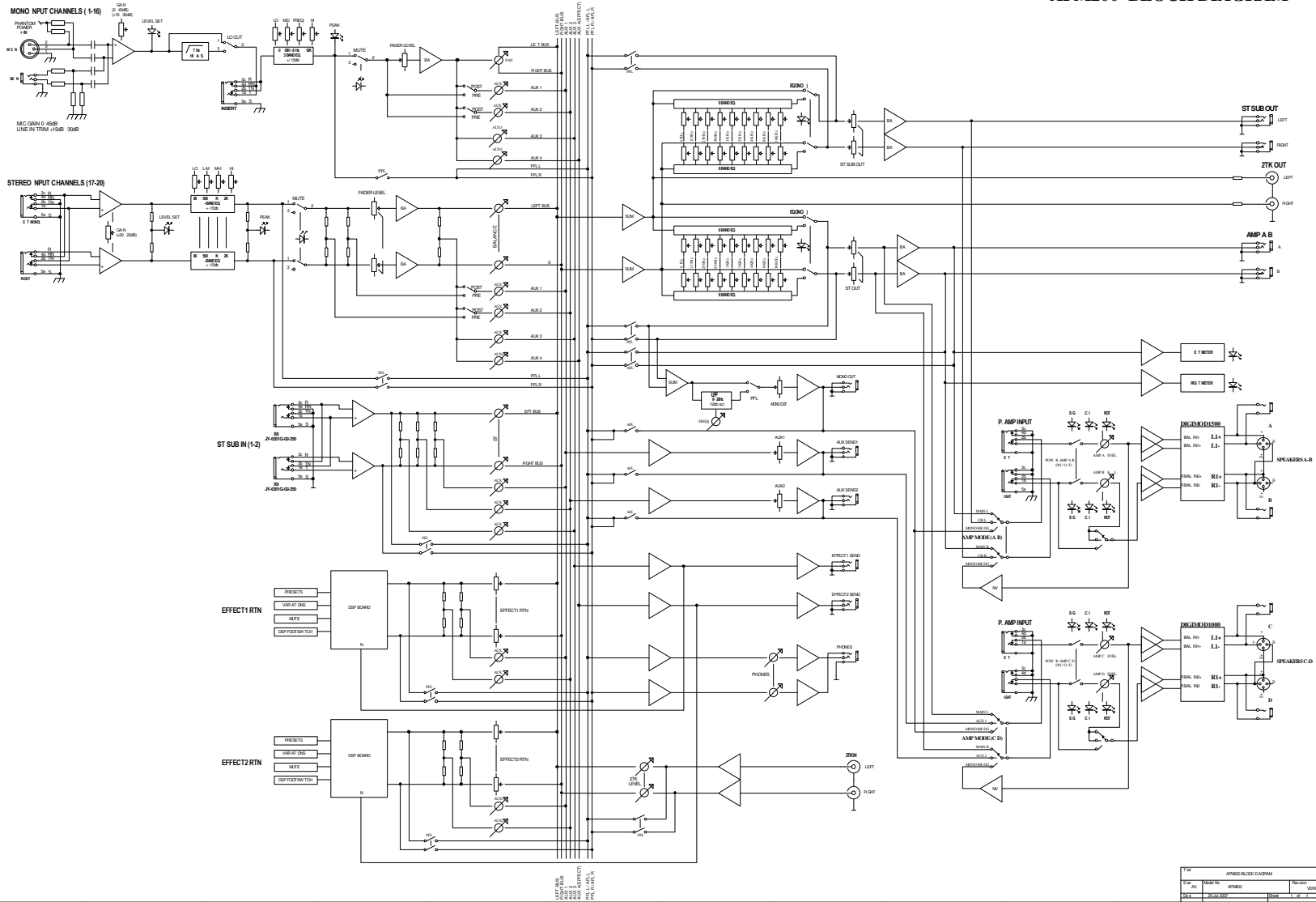

APM200_STEREO BOARD
VER070710(1/4)

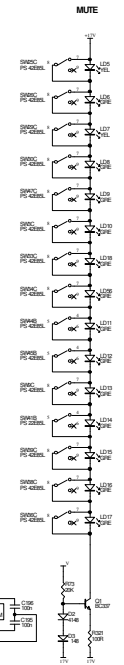
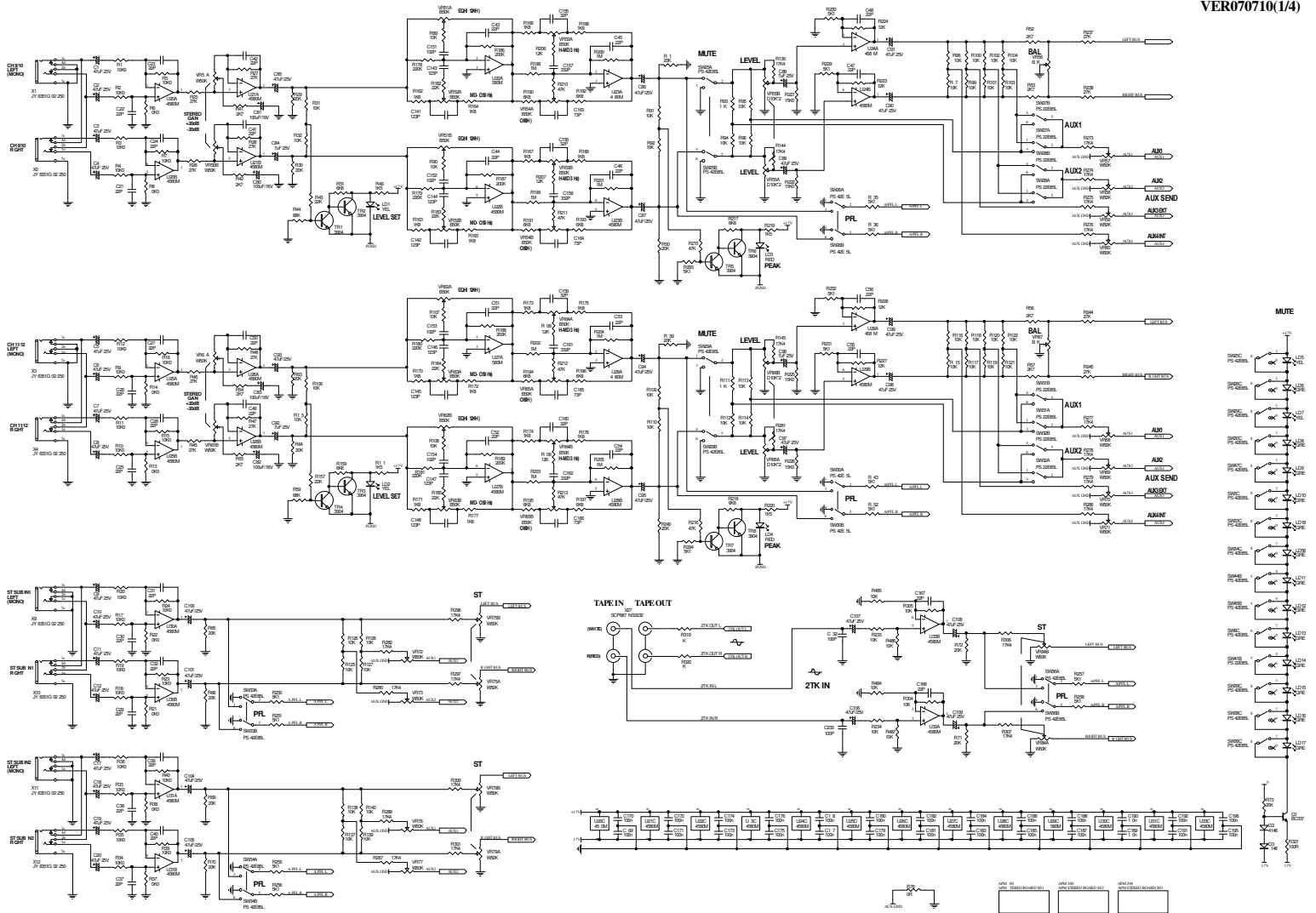

14	REVISION	
5	DATE	07/10/07
1	BY	VER070710
1	APP	

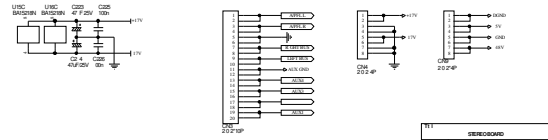
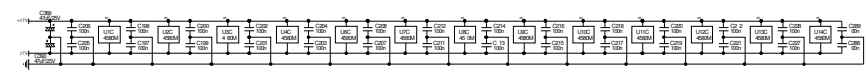
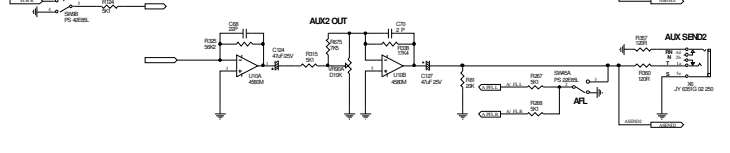
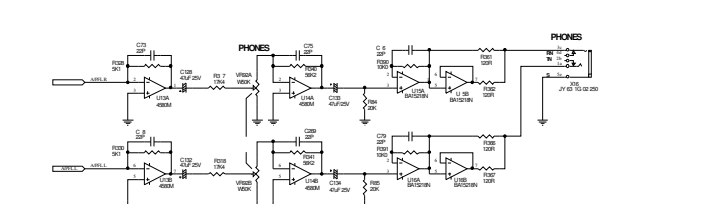
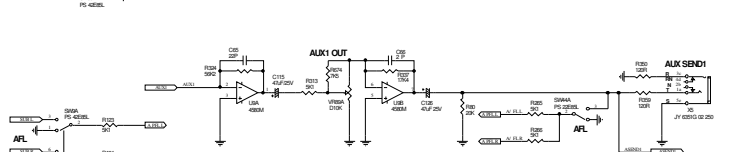
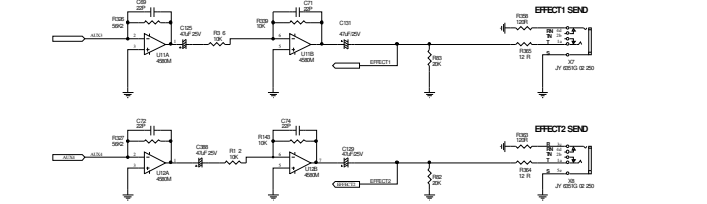
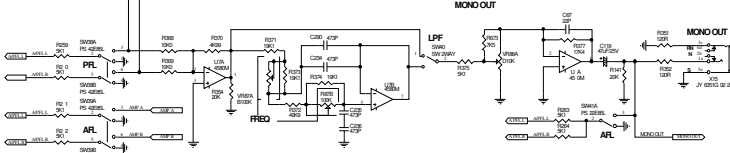
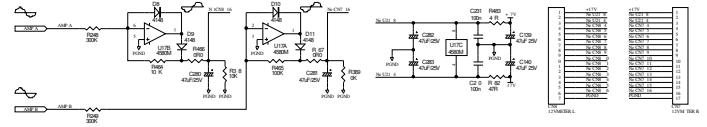
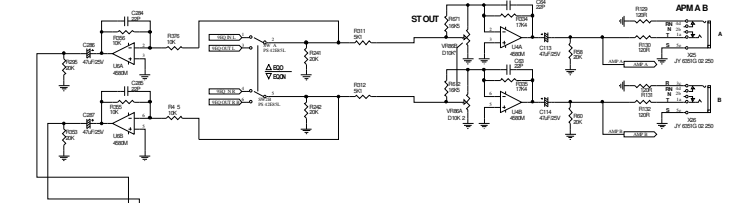
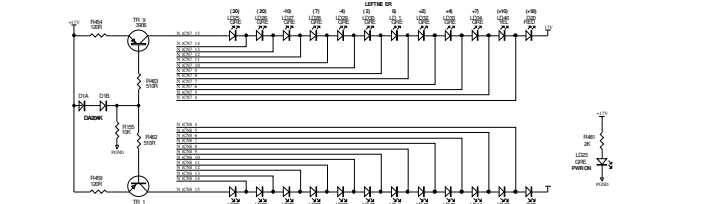
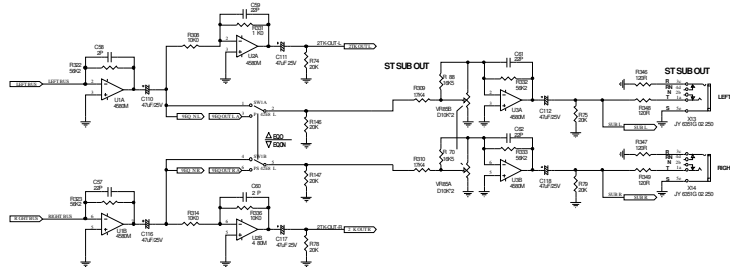

REV			
REV	DESCRIPTION	REV. #	DATE
01	STEREO BOARD		
02	ADD. REV. #	01	07/10/2007
03	ADD. REV. #	02	07/10/2007
04	ADD. REV. #	03	07/10/2007

9 BAND EQ

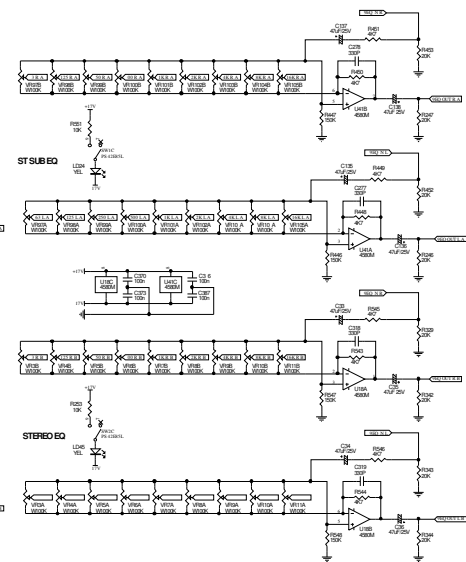
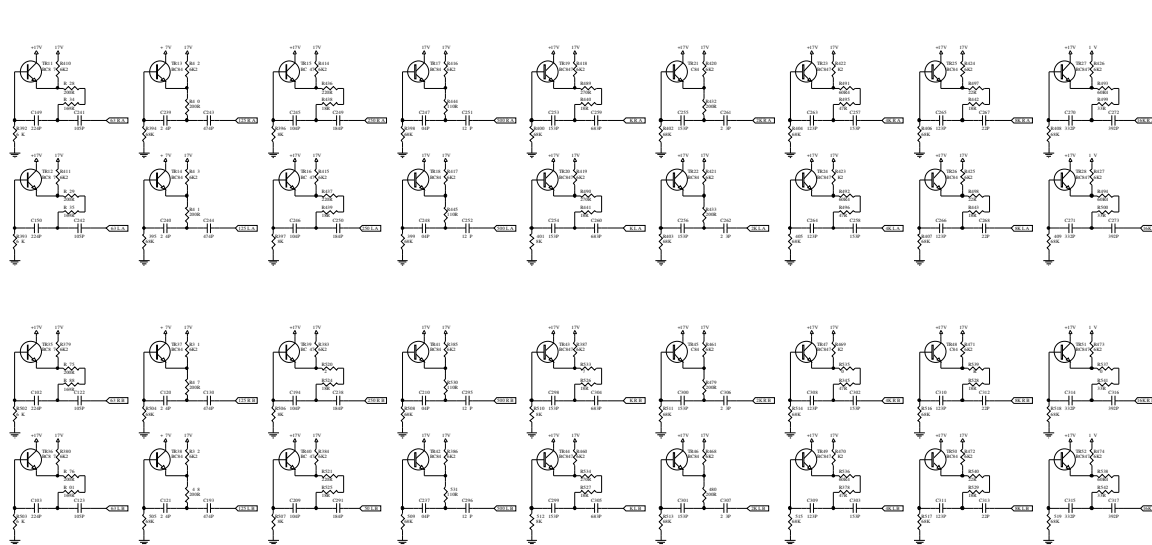

DSP

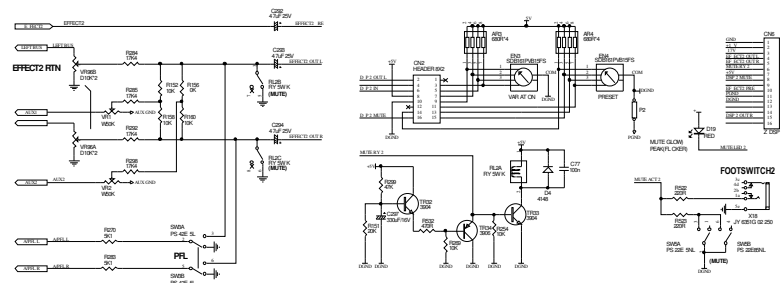
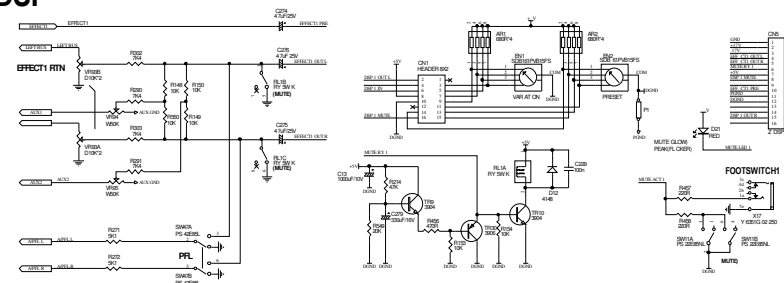

APM200_STEREO BOARD VER070710(4/4)

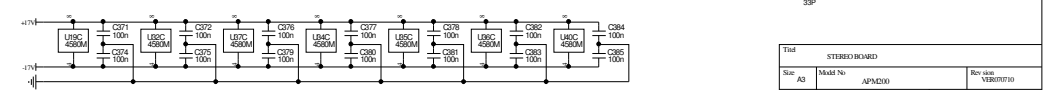
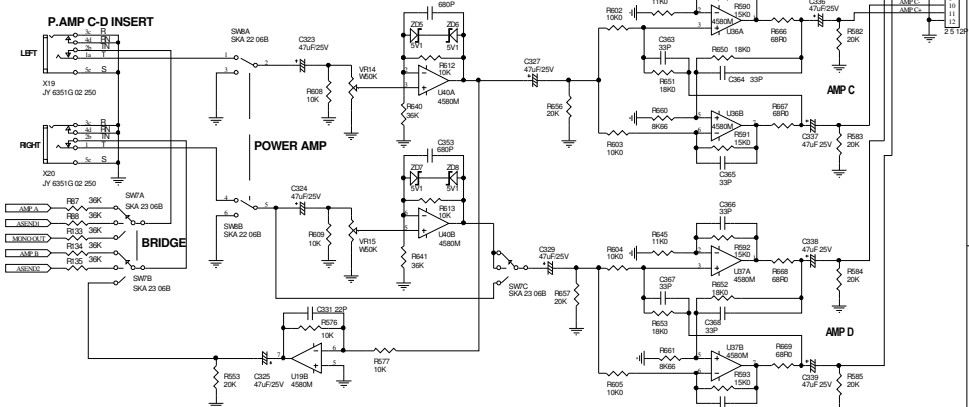
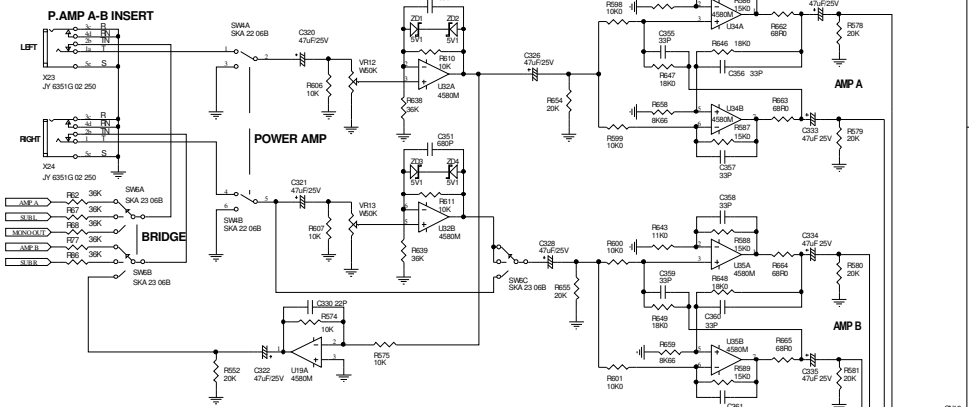
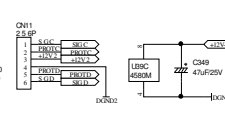
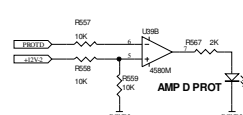
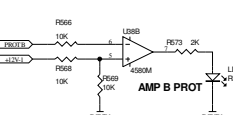
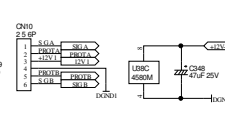
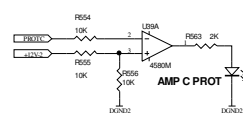
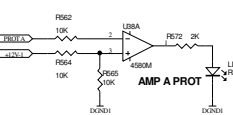
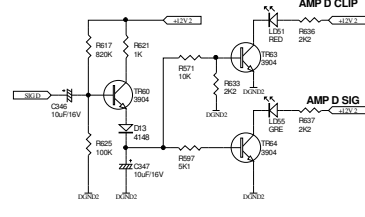
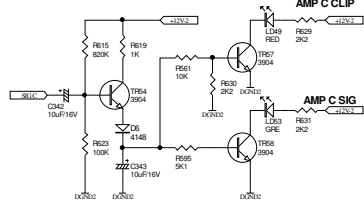
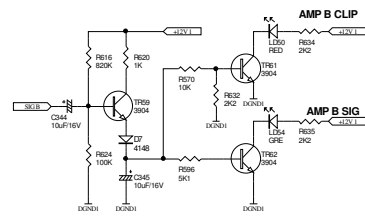
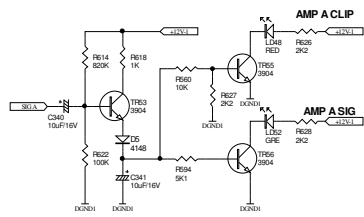

T14 STEREO BOARD			
Size	Model No	Rev	
A3	APM200	4/4	
Dr	3/1/80	Dr	3/1/80
Dr	3/1/80	Dr	3/1/80

APM120SPEAK(1/1)

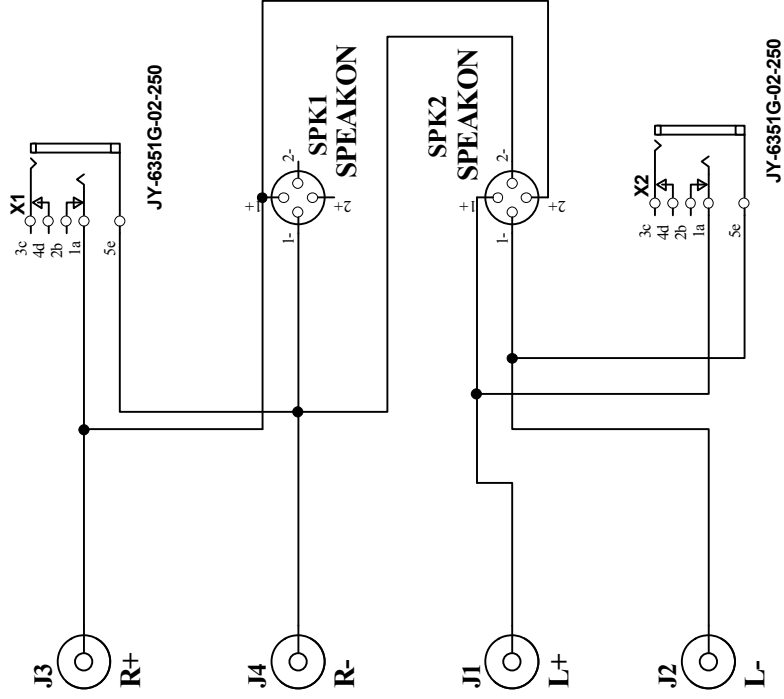

Title: APM120SPEAK

Size: A3 Model No: APM120 Revision: VER060721

Date: 19-Apr-2007 Sheet: 1 of 1
 File: APM120SPEAK SCH Drawn By: Jing Bo Yuan

APM MONO BOARD(1/1)

950922修改

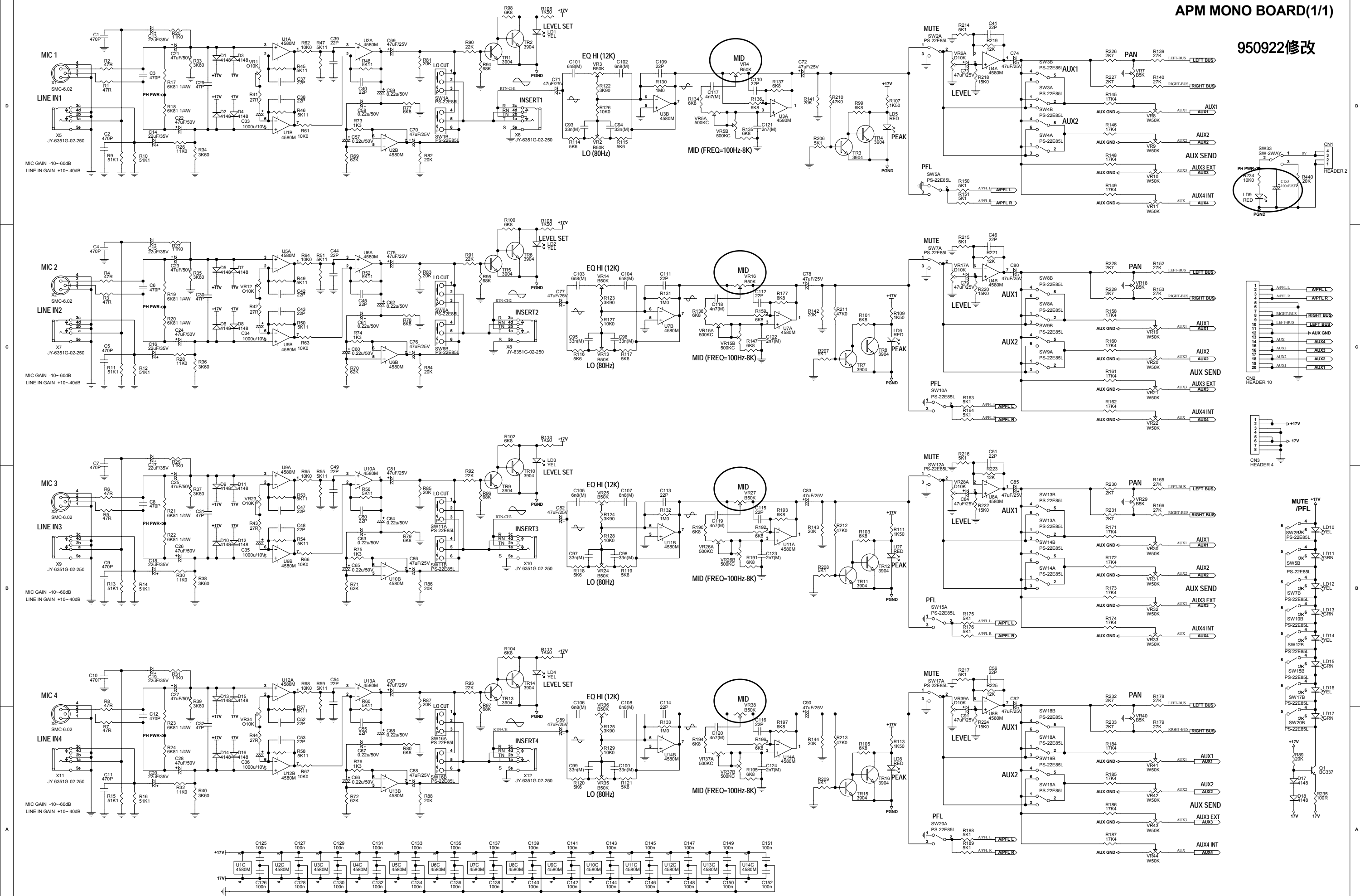

PSM-50Wd(1/1)

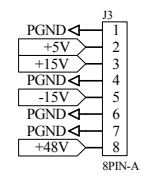
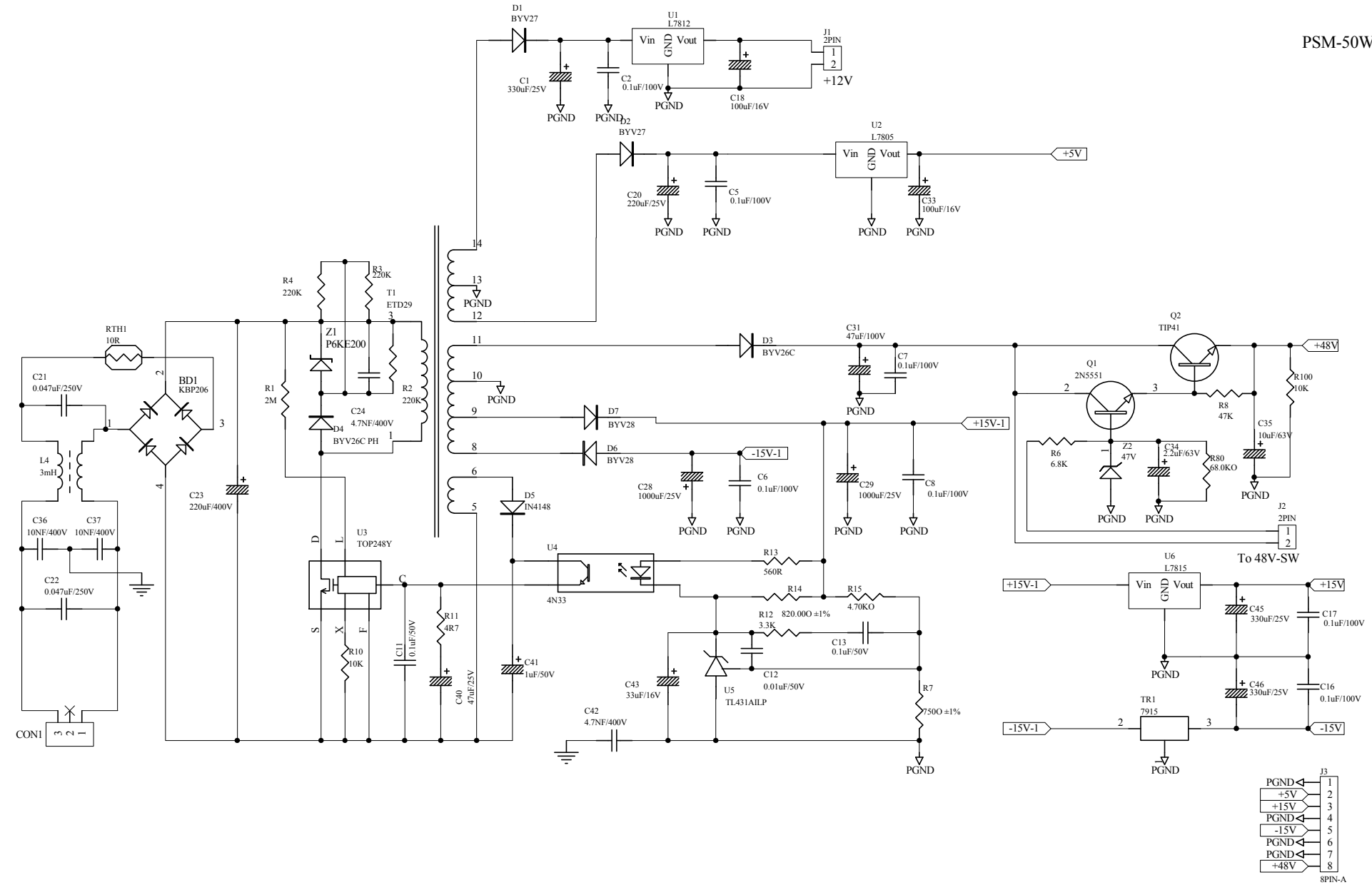

Titel			PSM-50Wd		
Size	A3	Model No:	PSM-50Wd	Revision	REV060822
Date:	28-Oct-2006	Sheet	1 of 1		
File:	PSM-50Wd 單塊pcb線路圖.SCH	Drawn By:	JXL		

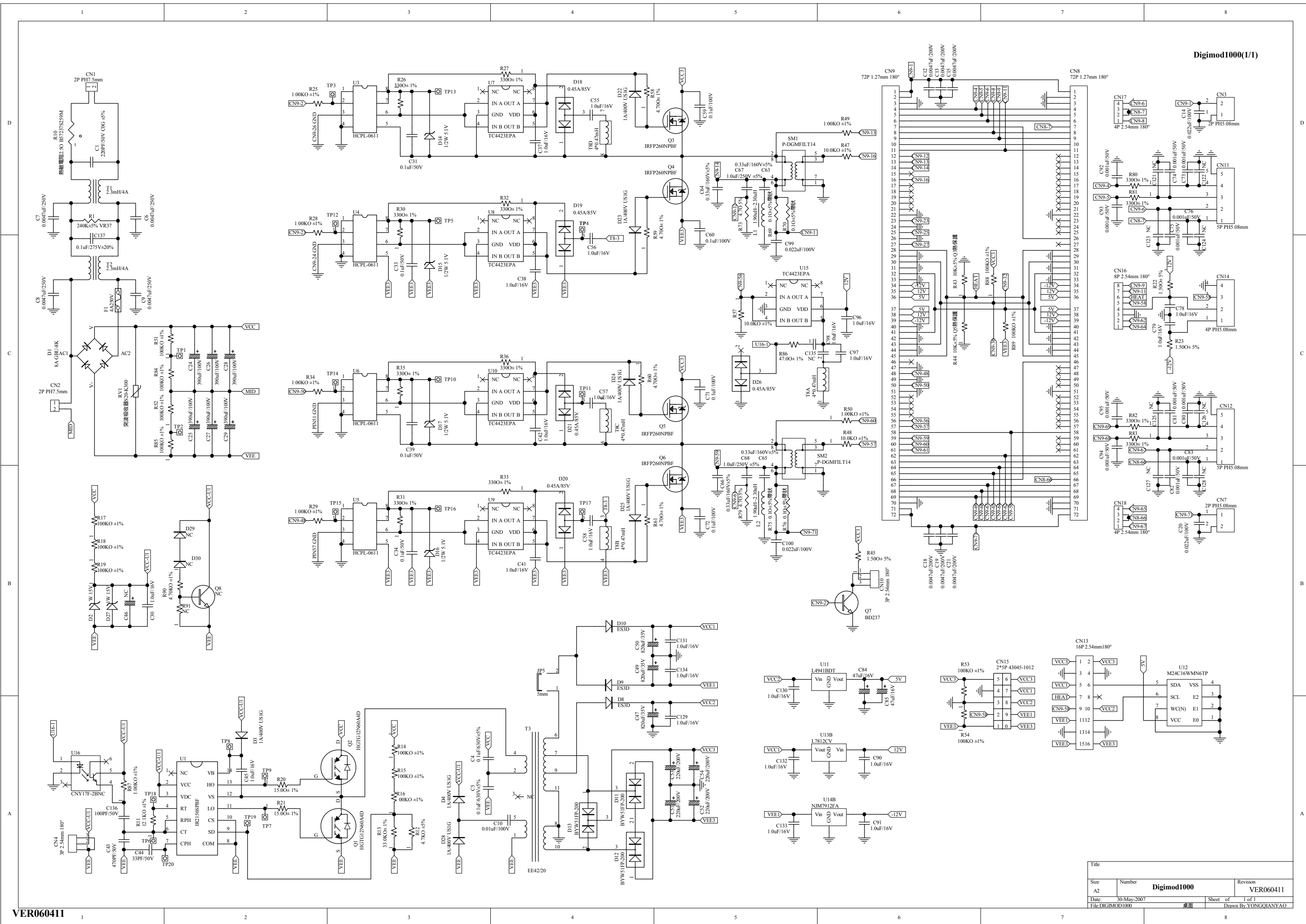

VER060411

Title		Revision	
Size	A2	Number	Digimod1000
Date	30-May-2007	Revision	VER060411
File	DIGIMOD1000	Sheet of	1 of 1
	桌面	Drawn By	YONGJIAN YAO

DSP-PRE

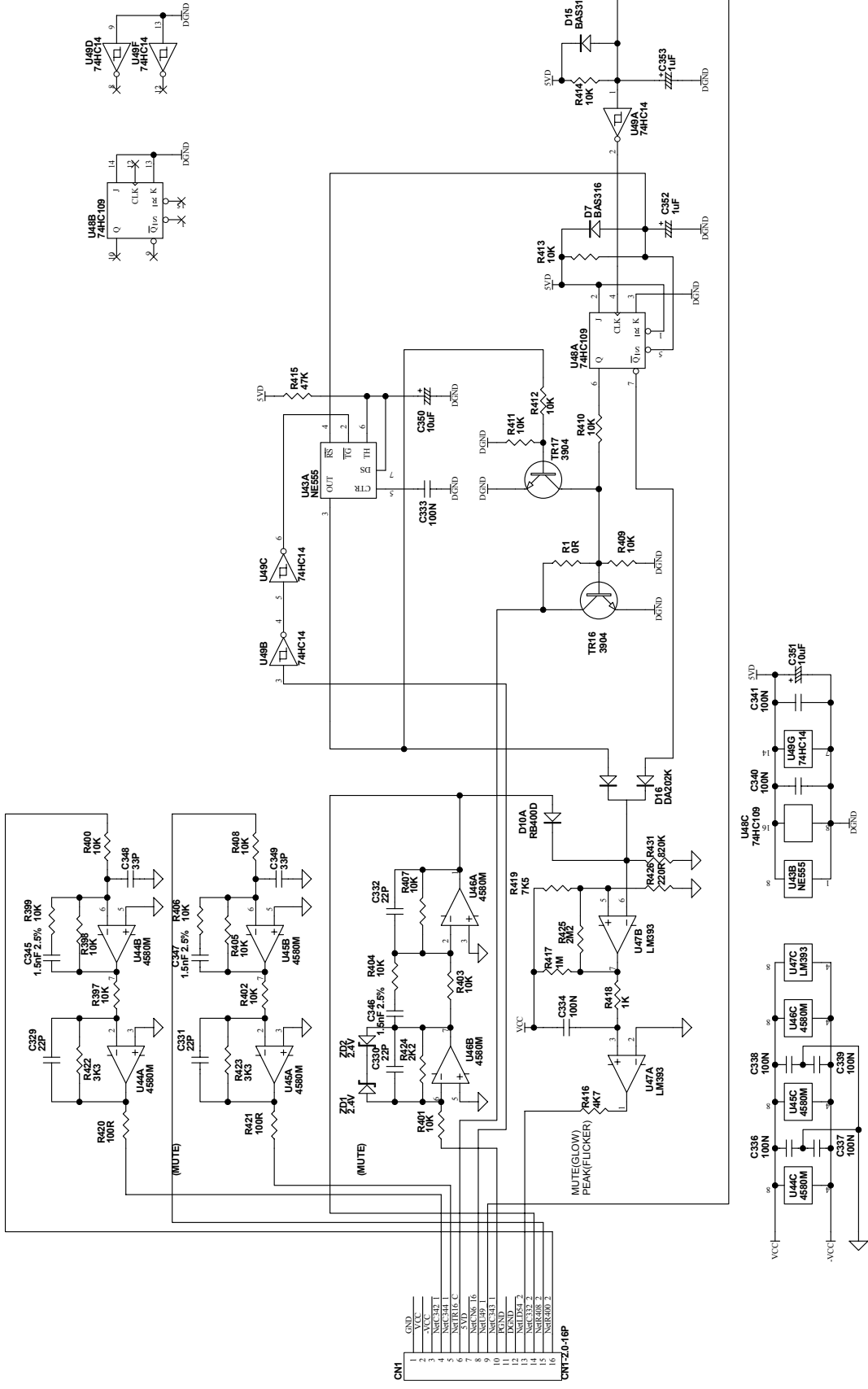

- CN1
- 1 GND
 - 2 VCC
 - 3 NSC/CH2
 - 4 NSC/CH1
 - 5 NSC/CH1
 - 6 SVD
 - 7 NSC/CH6/16
 - 8 NSC/CH1
 - 9 NSC/CH1
 - 10 P/END
 - 11 D/END
 - 12 NSC/CH3/2
 - 13 NSC/CH3/2
 - 14 NSR/DIR0
 - 15 NSR/DIR0
 - 16 NSR/DIR0
- CNT-Z0-16P

Title		DSP-PRE	
Model No	AMX-140FX USB	Revision	REV1.1 (05/11/22)
Size	A2(C)	Sheet	1 of 1
Date	23-Nov-2005	Drawn By	KEVIN LIN
File	DSP-PRE.Sch		

12VMETER

CN6

1	+VCC
2	NetU21_8
3	NetU21_4
4	+18DB-L
5	+10DB-L
6	+7DB-L
7	+4DB-L
8	+2DB-L
9	0DB-L
10	-2DB-L
11	-4DB-L
12	-7DB-L
13	-10DB-L
14	-20DB-L
15	-30DB-L
16	NetU15_11
17	PGND

Z-LED

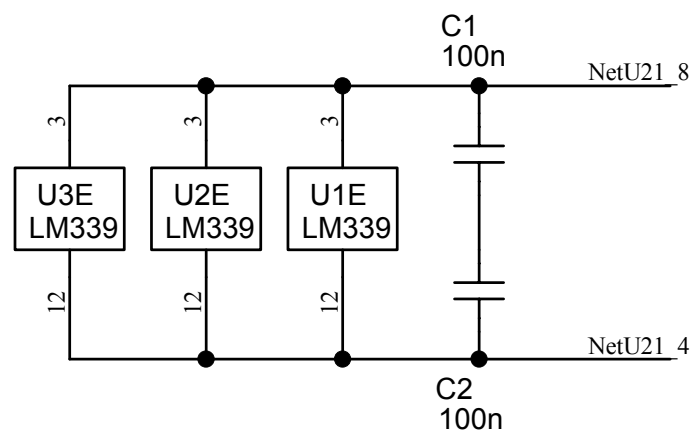
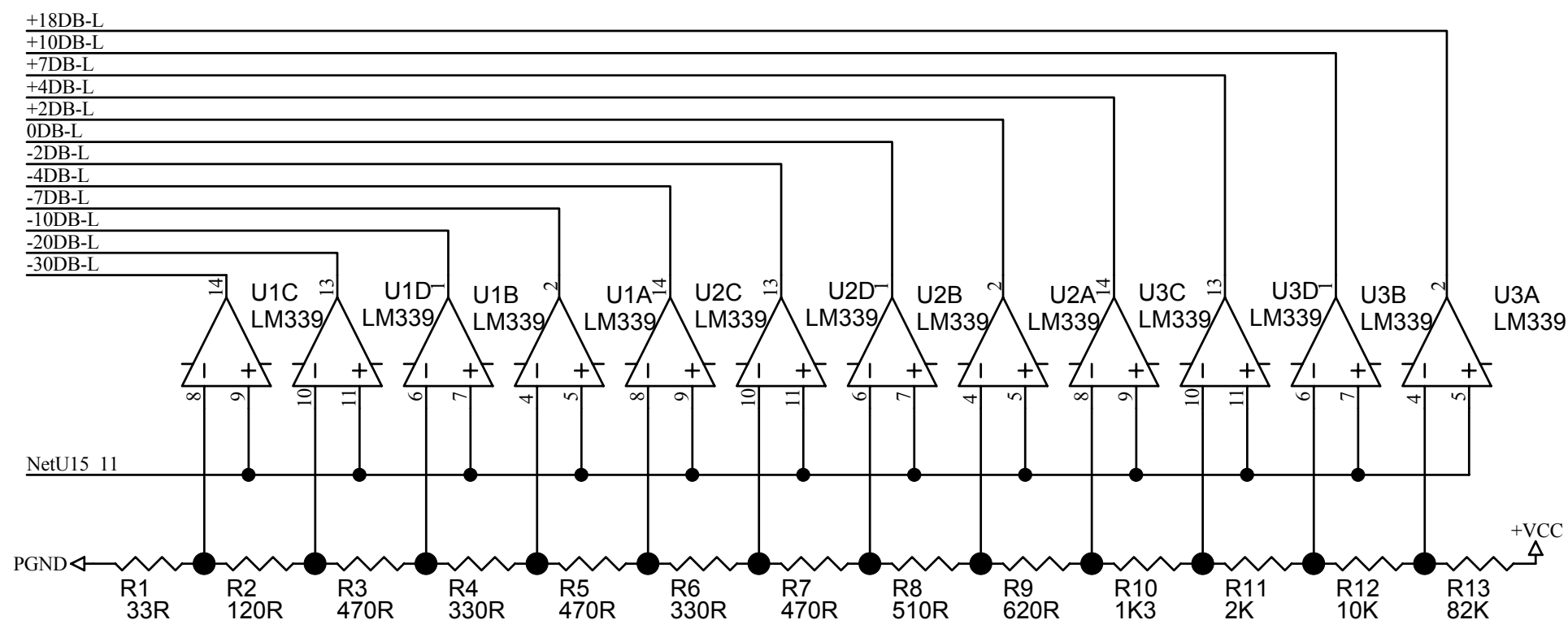

Titel		12VMETER	
Size	Model No:	Revision	
A4	12VMETER	VER040611	
Date:	4-Mar-2005	Sheet	1 of 1
File:	12VMETER.Sch	Drawn By:	

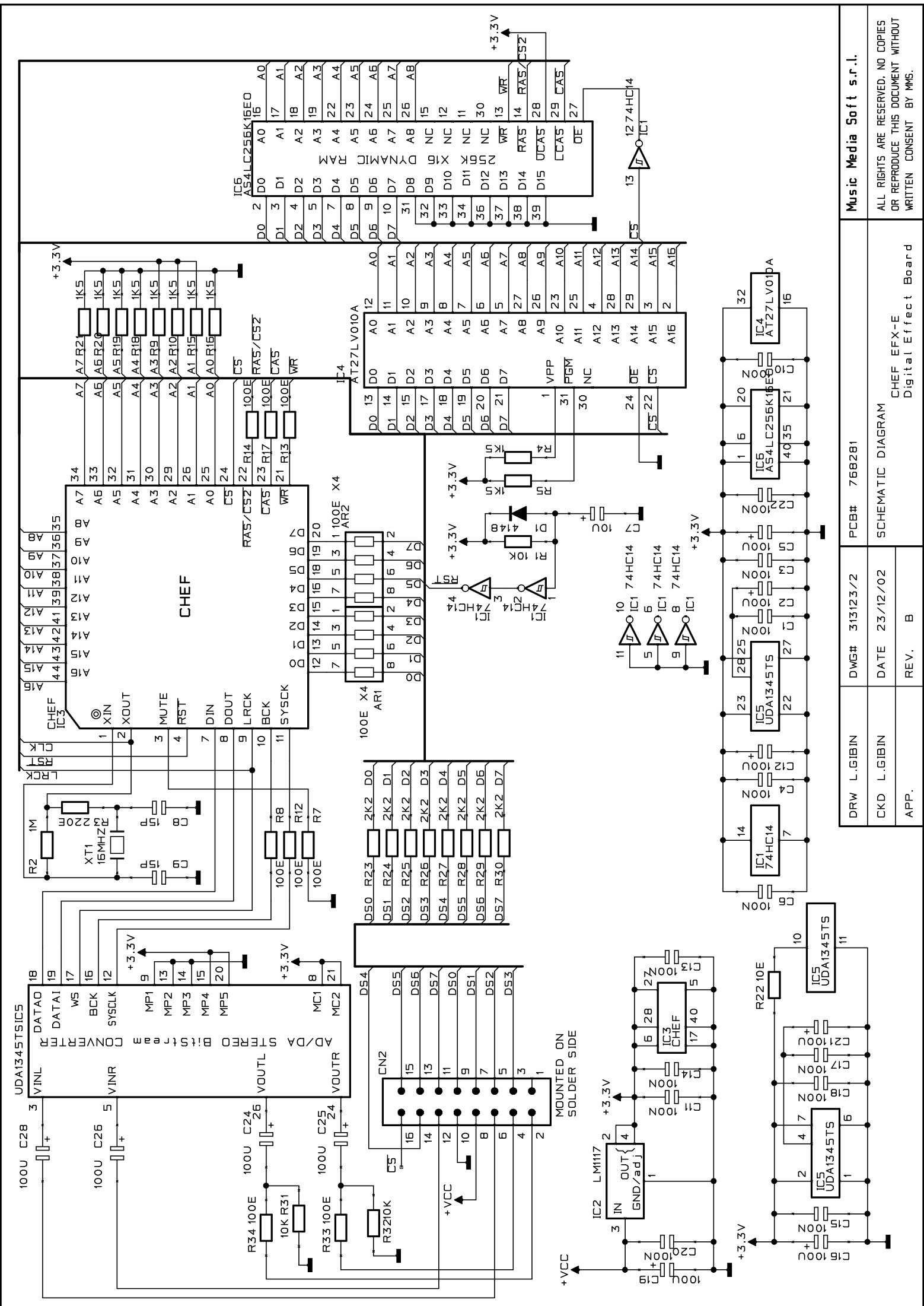

Music Media Soft s.r.l.
 ALL RIGHTS ARE RESERVED, NO COPIES
 OR REPRODUCE THIS DOCUMENT WITHOUT
 WRITTEN CONSENT BY MMS.

DRW L.GIBBIN DWG# 313123/2 PCB# 768281
 CKD L.GIBBIN DATE 23/12/02
 APP. REV. B

SCHMATIC DIAGRAM
 CHEF EF-E
 Digital Effect Board

Music Media Soft s.r.l.
 ALL RIGHTS ARE RESERVED, NO COPIES
 OR REPRODUCE THIS DOCUMENT WITHOUT
 WRITTEN CONSENT BY MMS.

APM200 接線圖

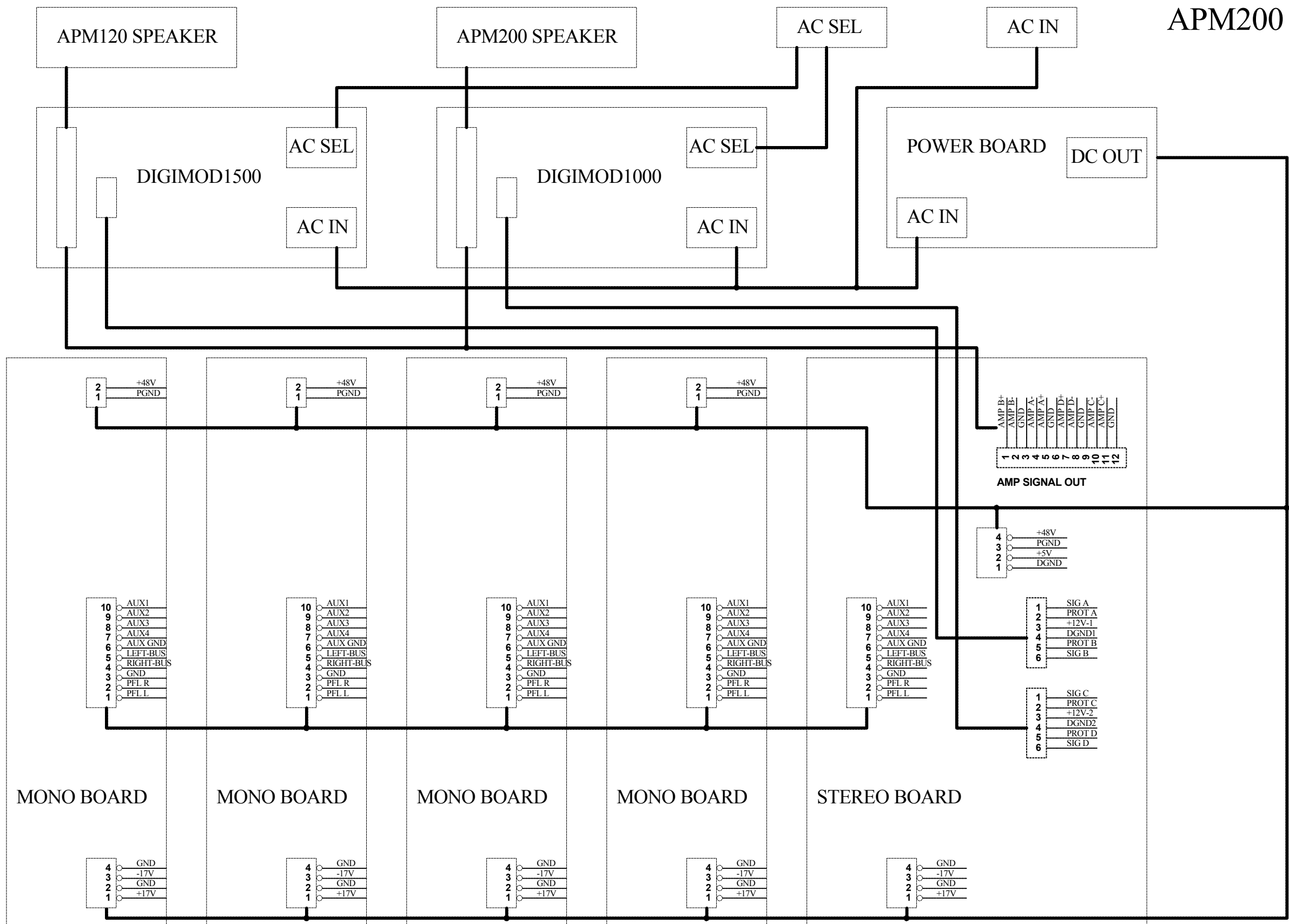

Titel		
APM CONNECTOR		
Size	Model No:	Revision
A2	APM200	VER070610
Date:	24-Aug-2007	Sheet 1 of 1
File:	APM200全機配線圖.SCH	Drawn By: JINBO YUAN

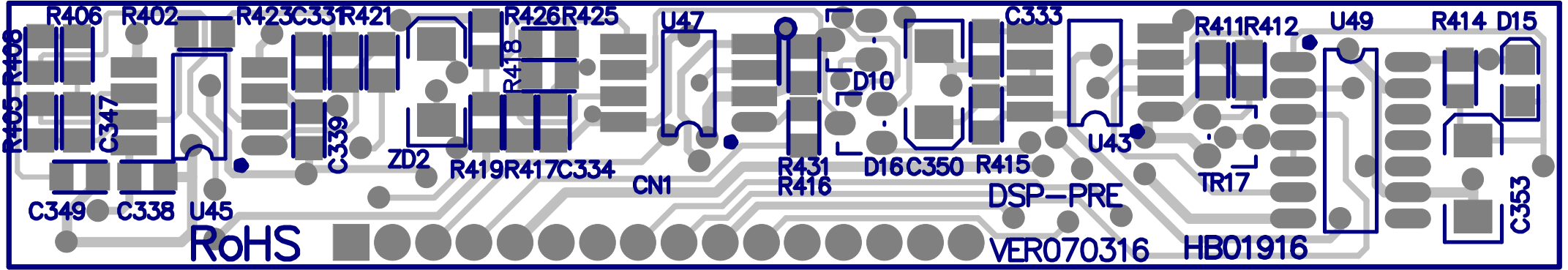
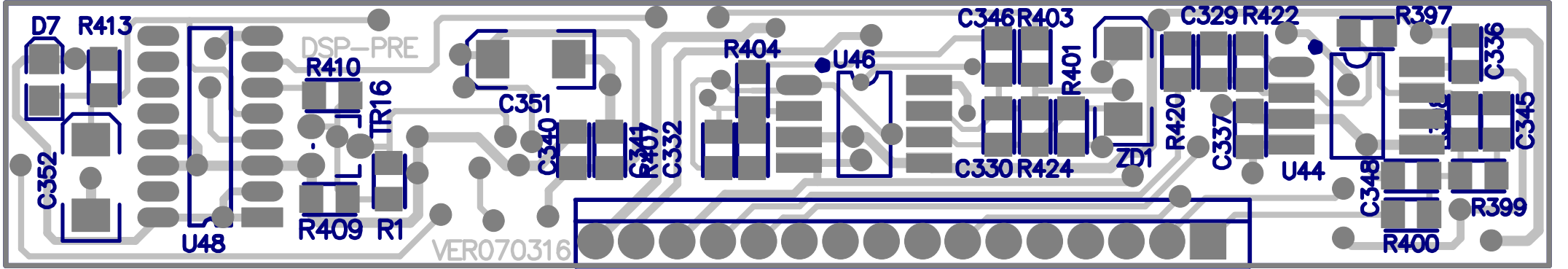

313123/2 I' INTERNAL LAYER GND

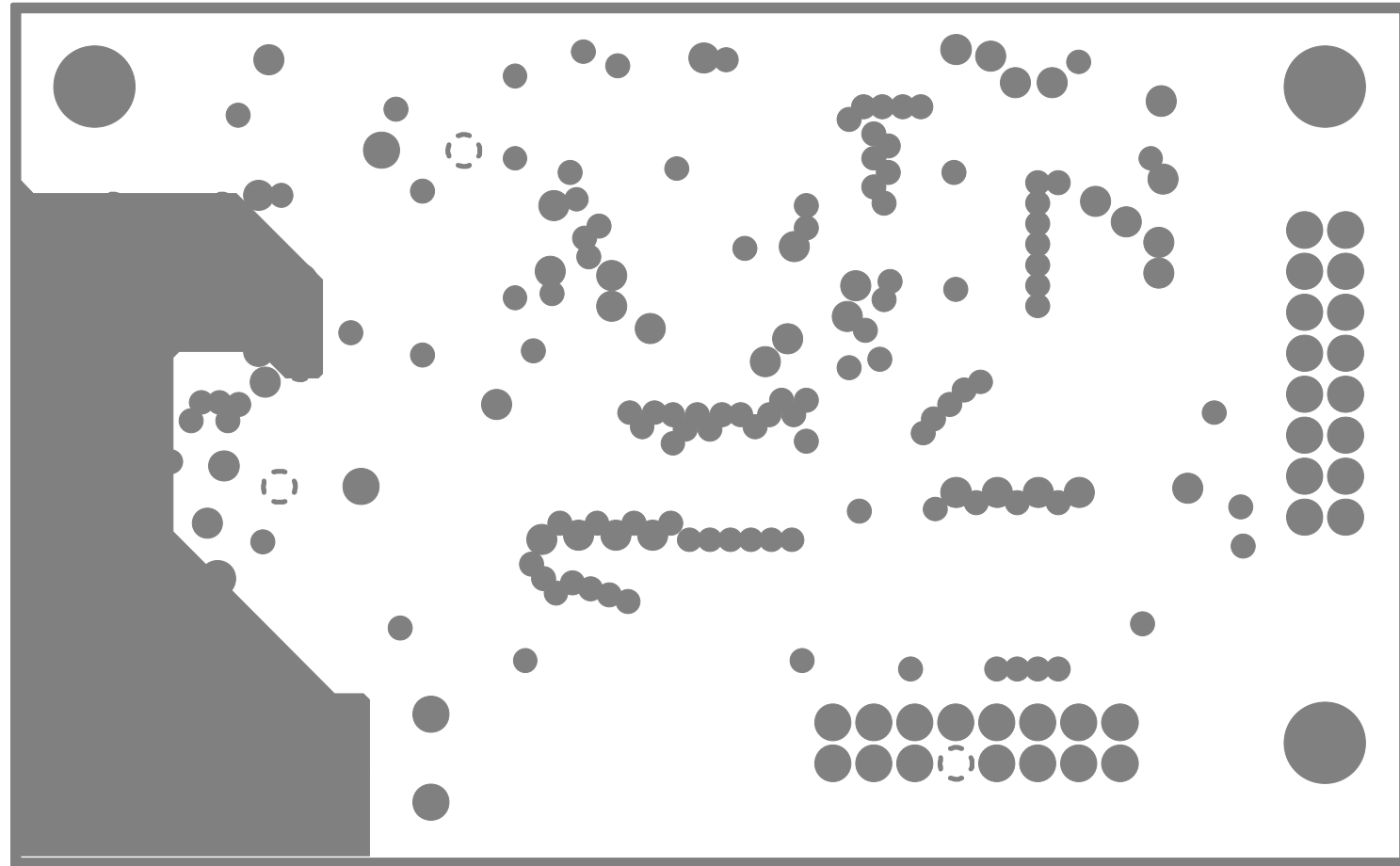

313123/2 SOLDER RESIST SOLDER SIDE

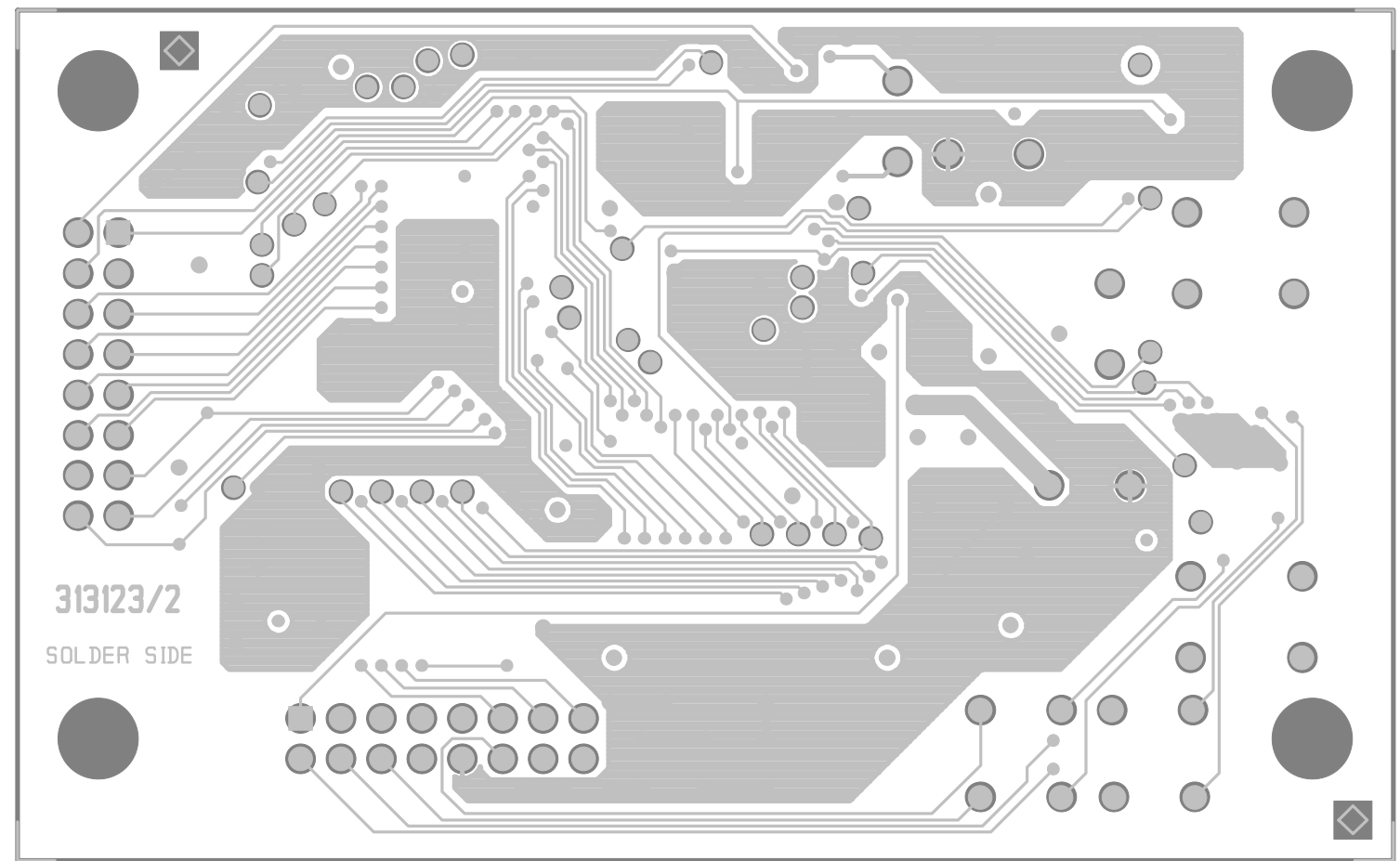

313123/2 II' INTERNAL LAYER VCC

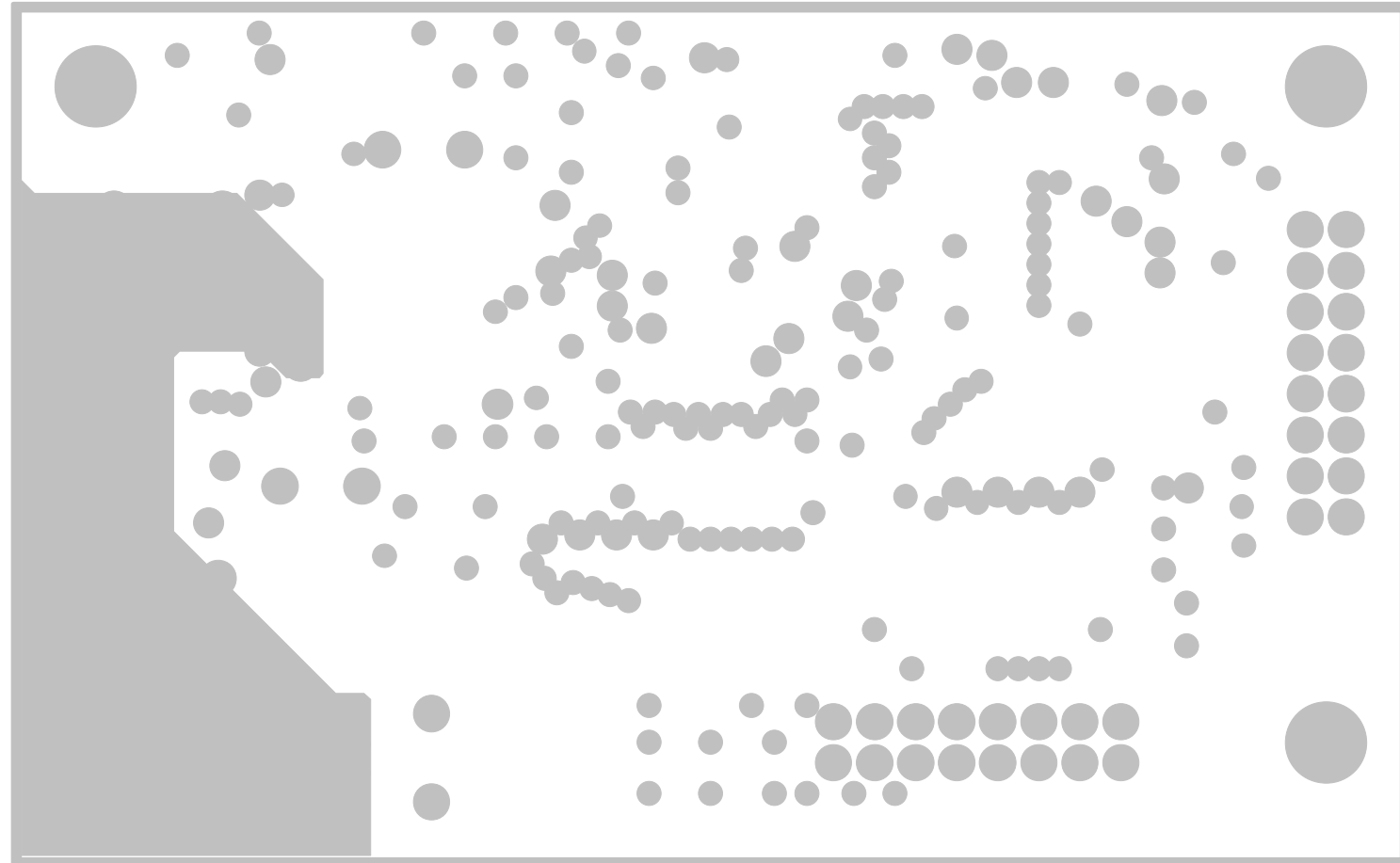

313123/2 TOP SILK RESIST COMP. SIDE

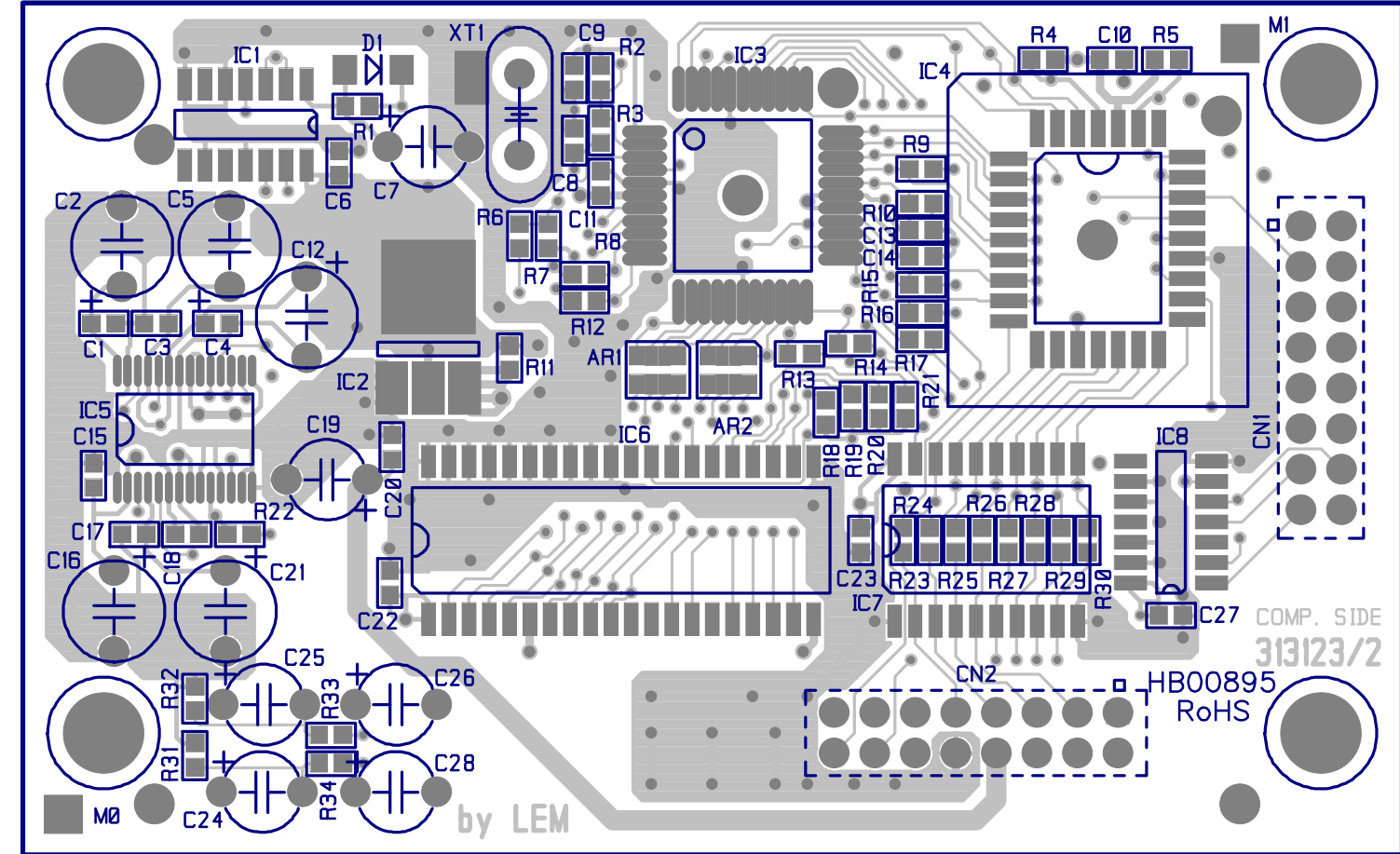

➤ PUNTO DI RIFERIMENTO PER LAVORAZIONE PCB

➤ PUNTO DI RIFERIMENTO PER LAVORAZIONE PCB

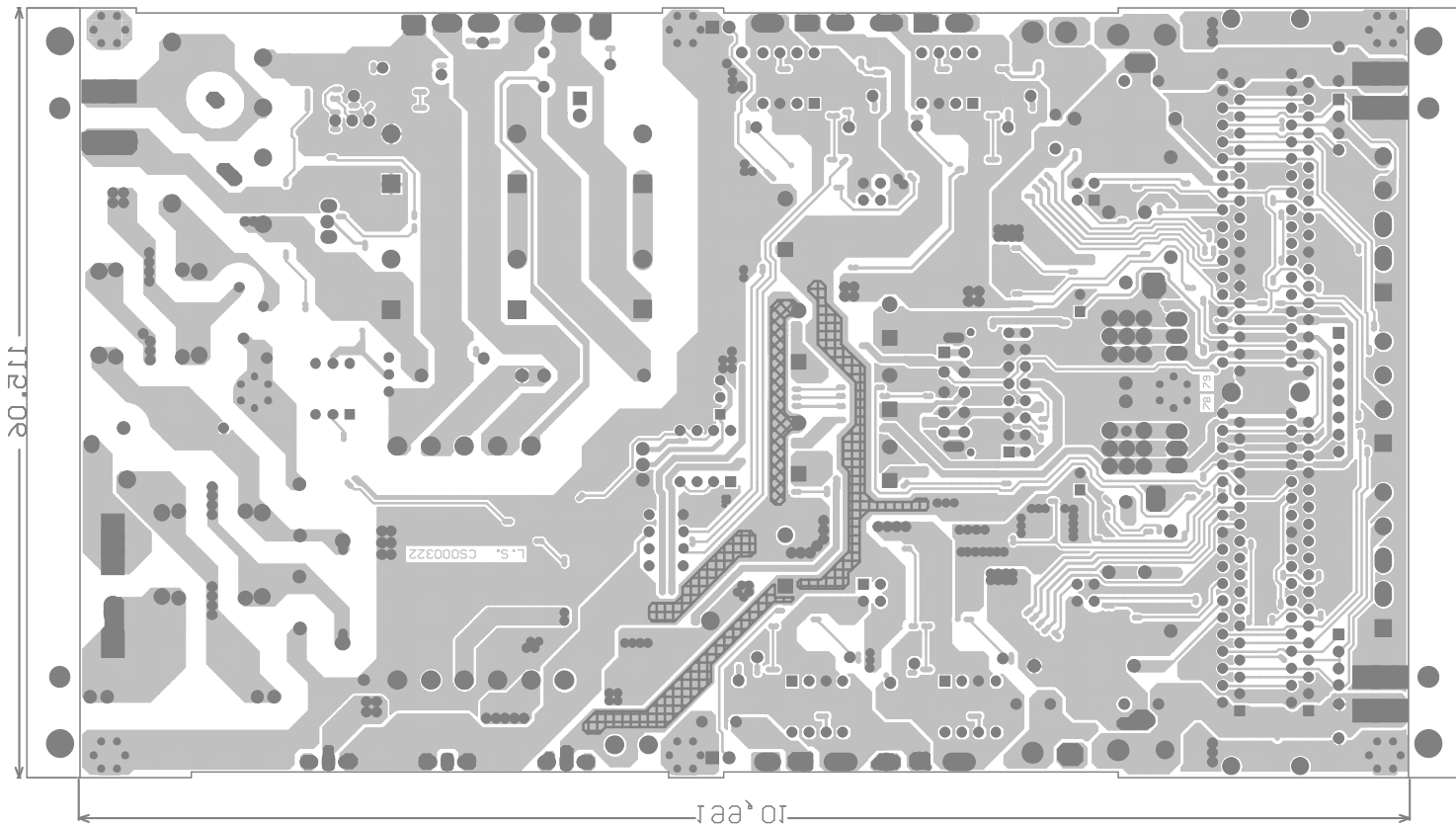

➤ PUNTO DI RIFERIMENTO PER LAVORAZIONE PCB

➤ PUNTO DI RIFERIMENTO PER LAVORAZIONE PCB

➤ PUNTO DI RIFERIMENTO PER LAVORAZIONE PCB

➤ PUNTO DI RIFERIMENTO PER LAVORAZIONE PCB

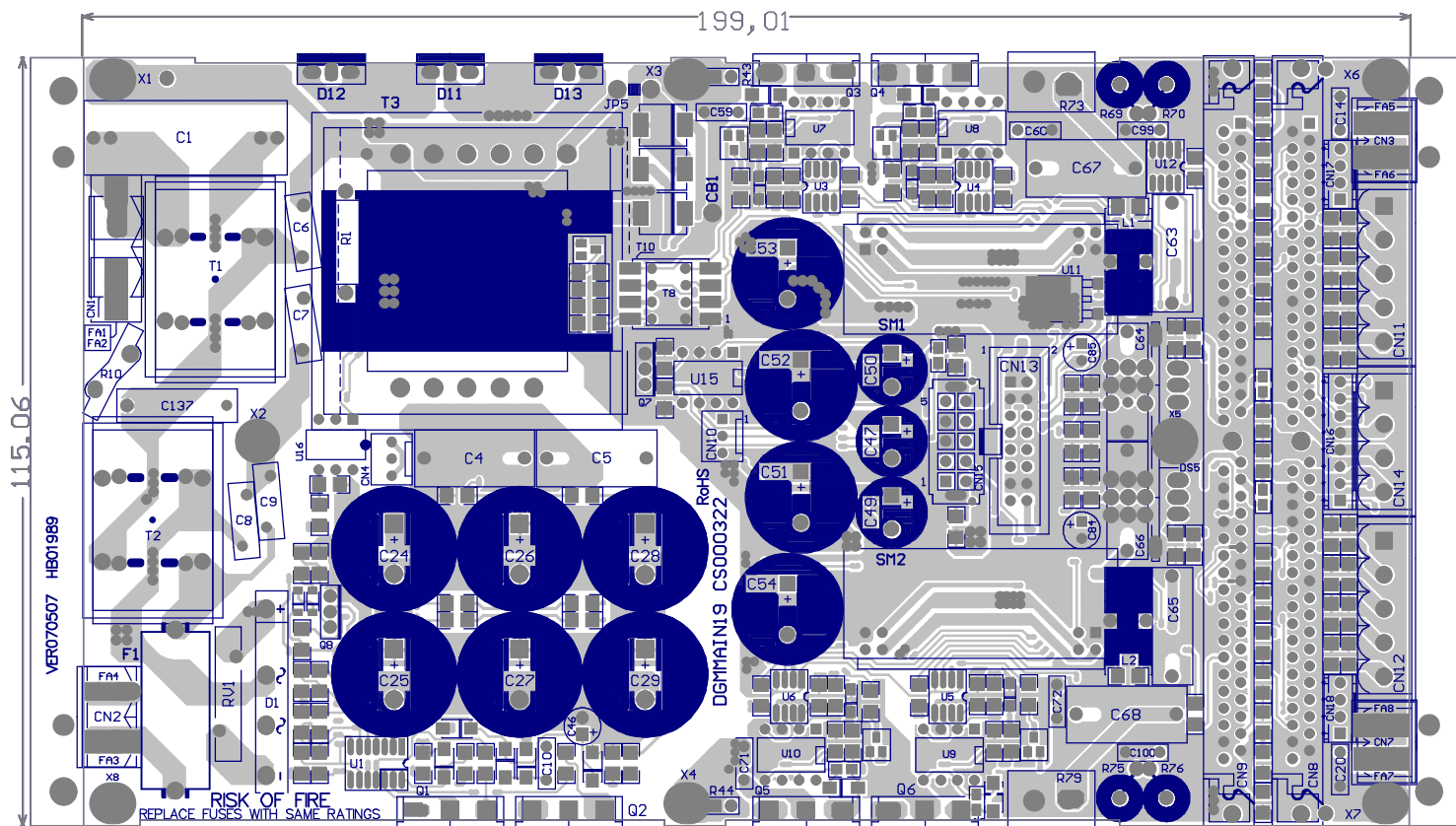

➤ PUNTO DI RIFERIMENTO PER LAVORAZIONE PCB

➤ PUNTO DI RIFERIMENTO PER LAVORAZIONE PCB

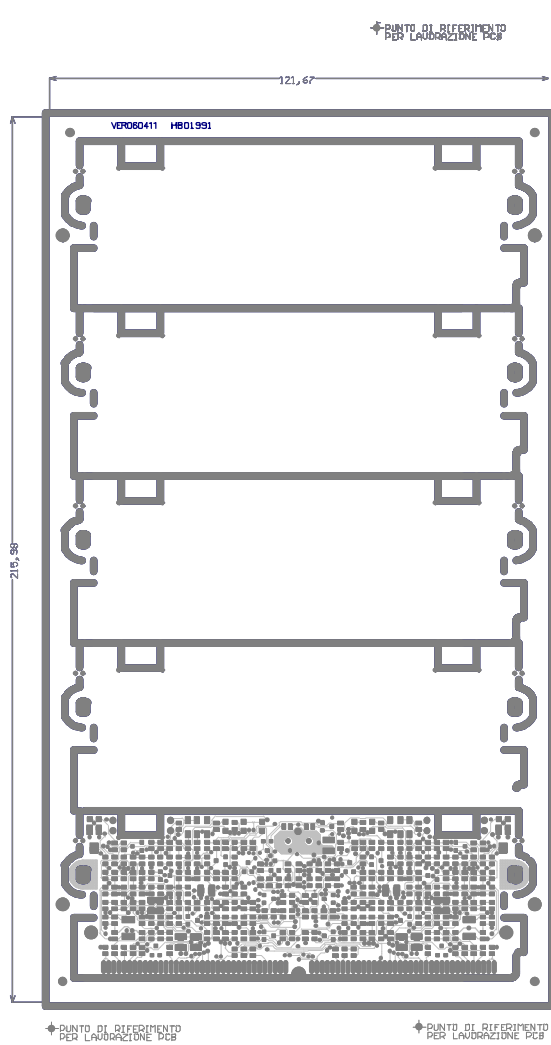
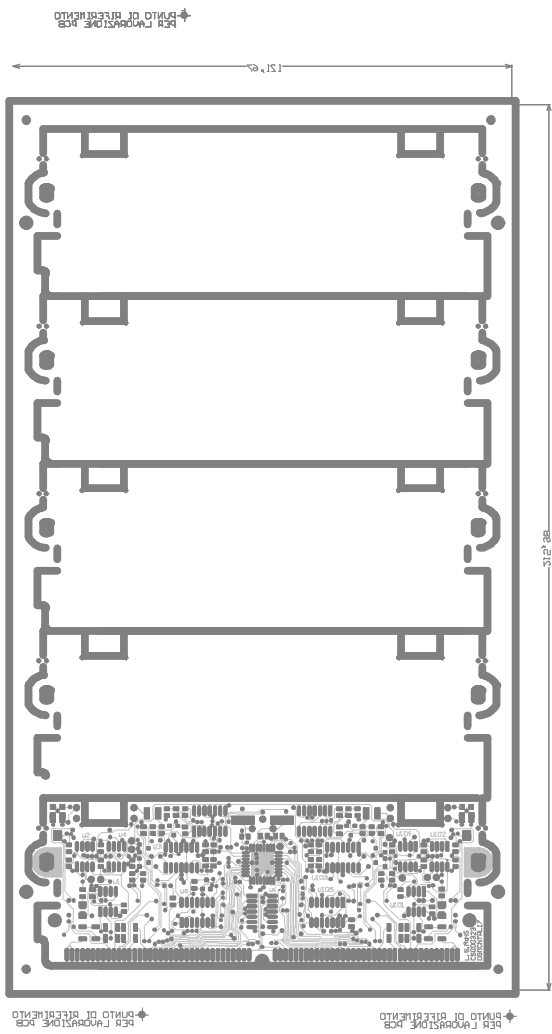
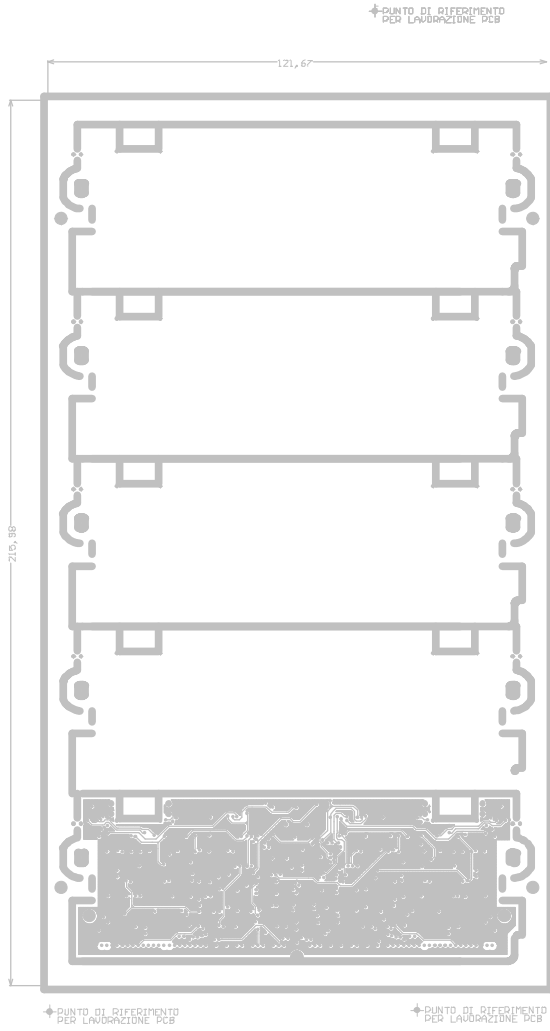
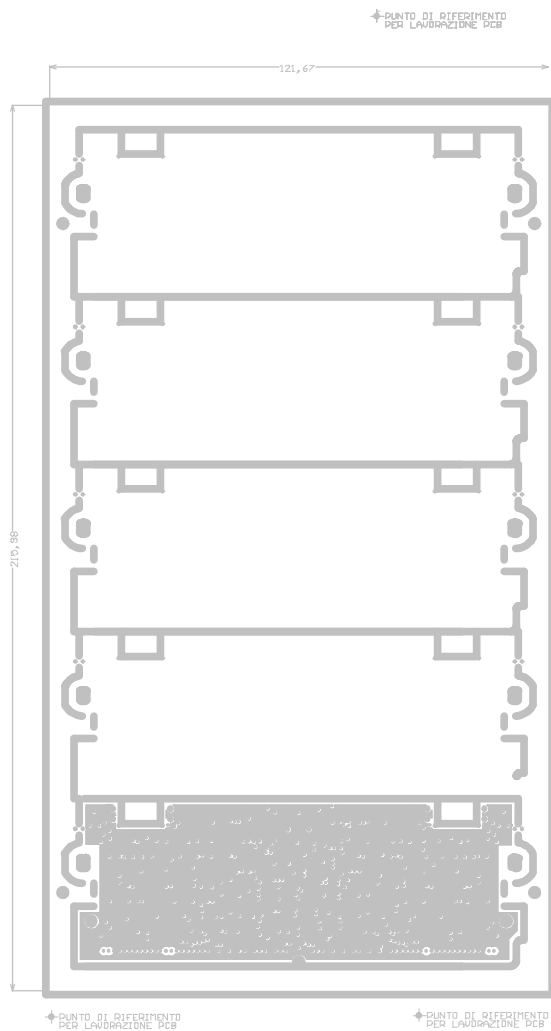

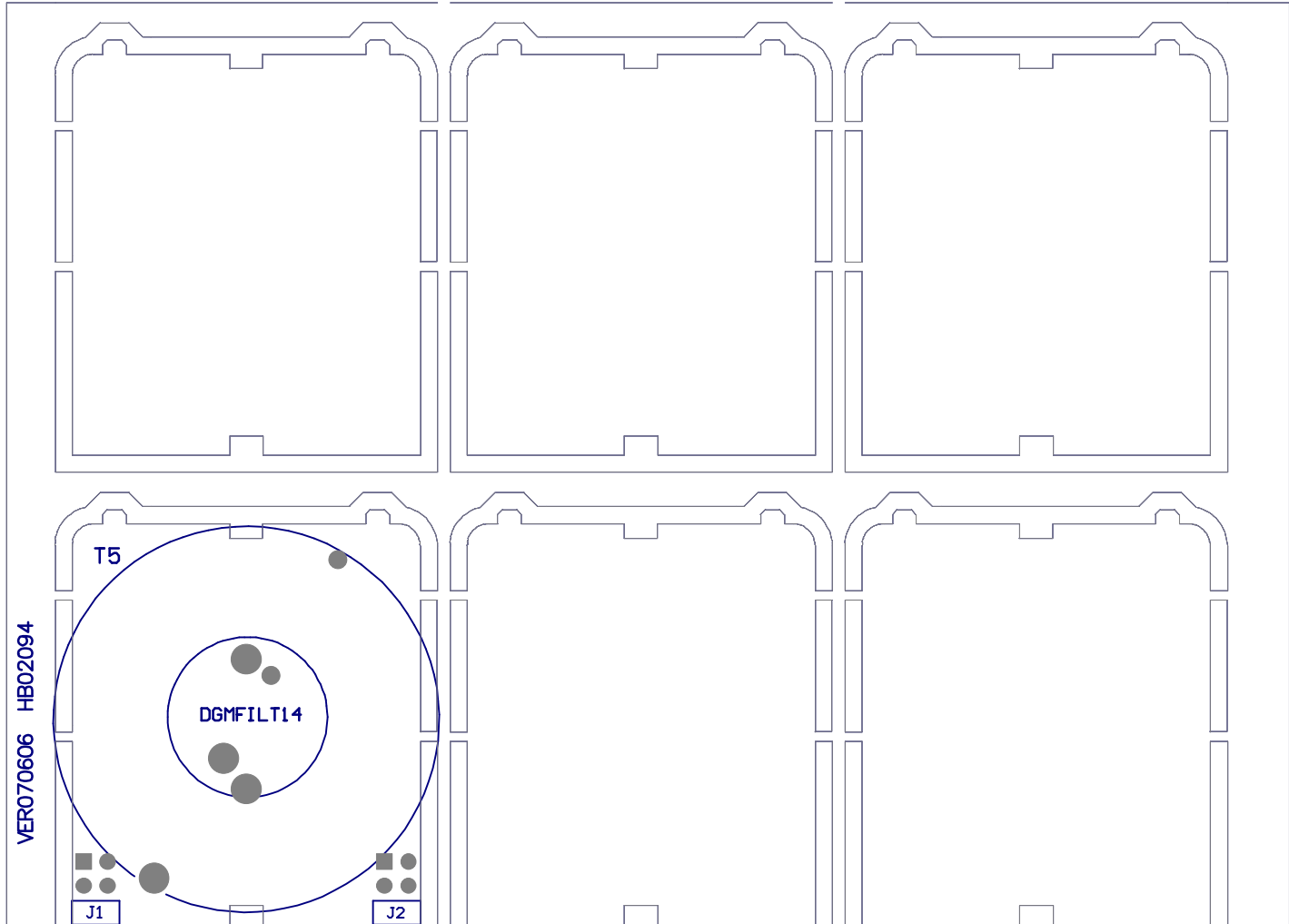
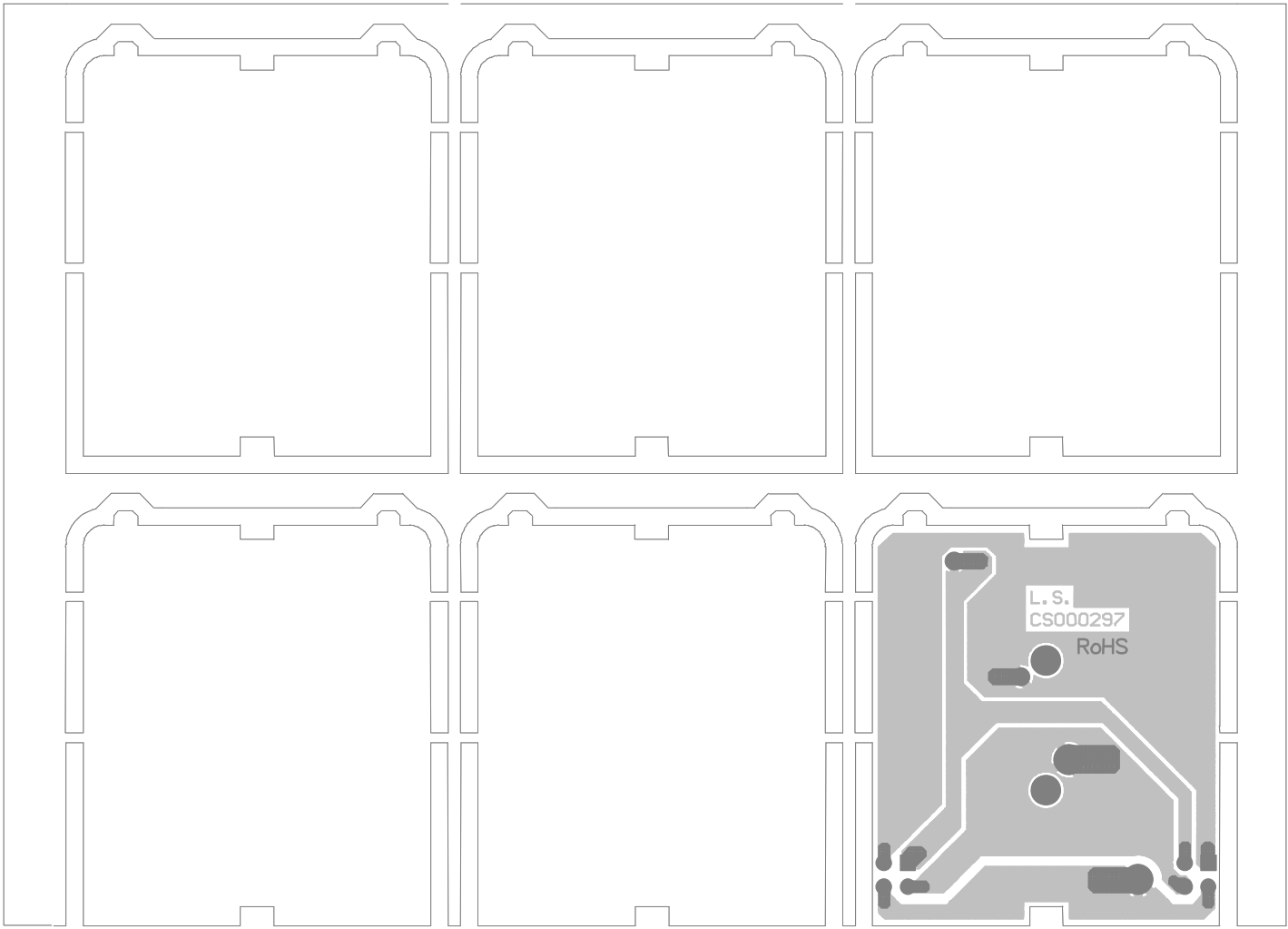

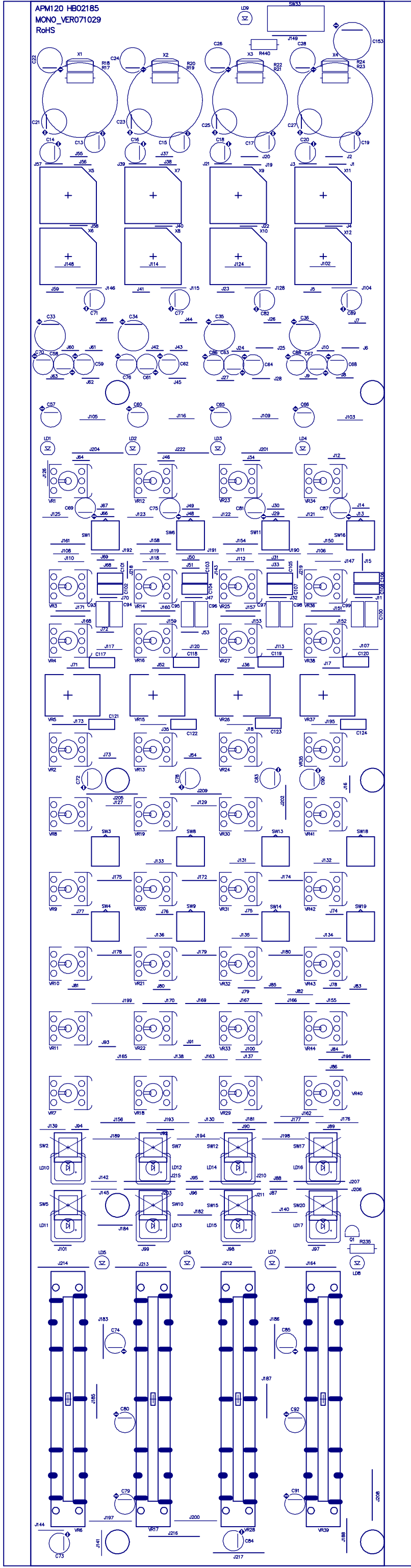
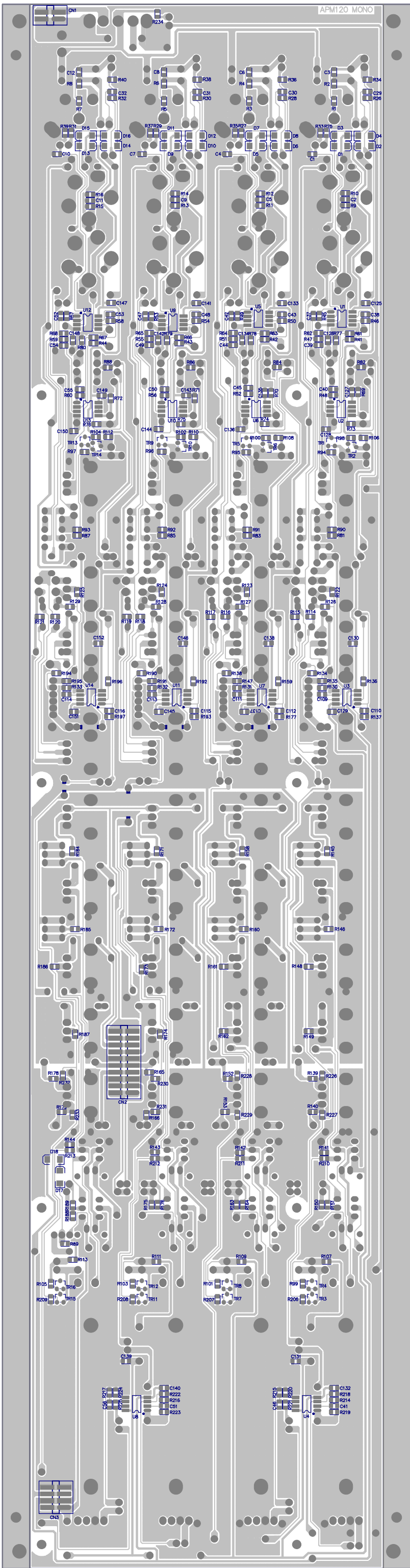

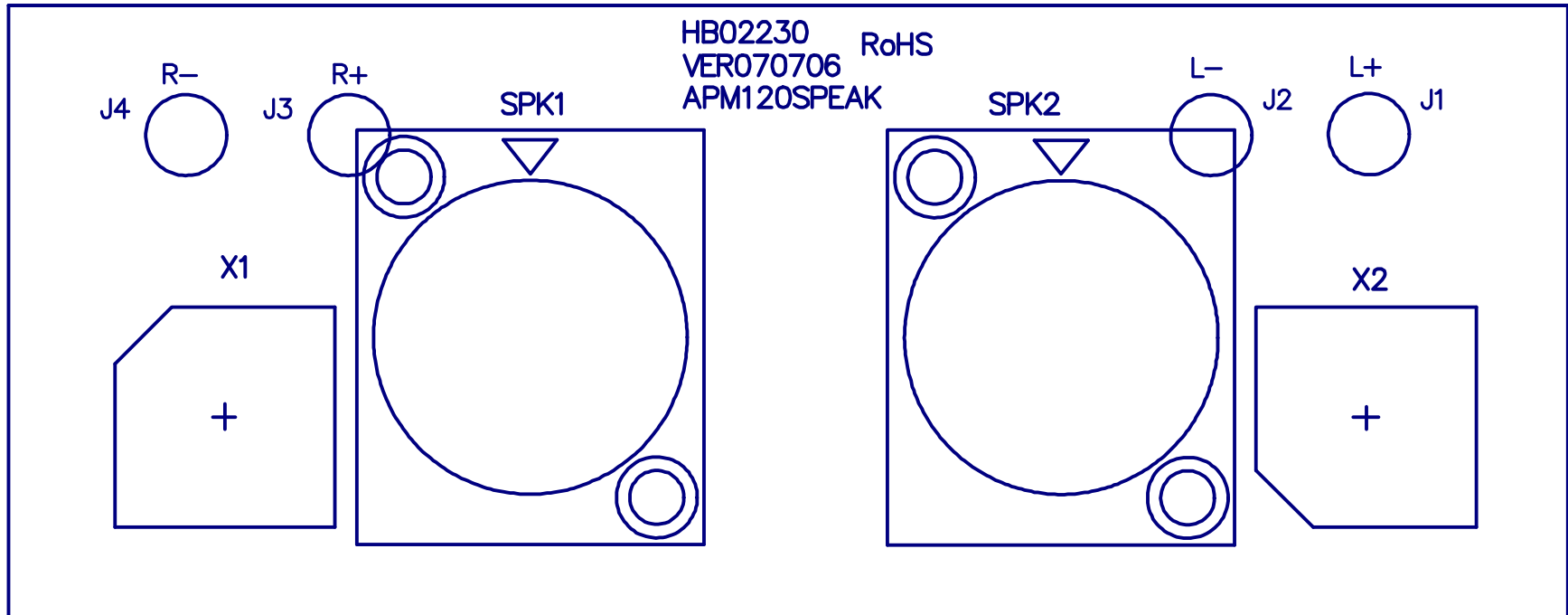
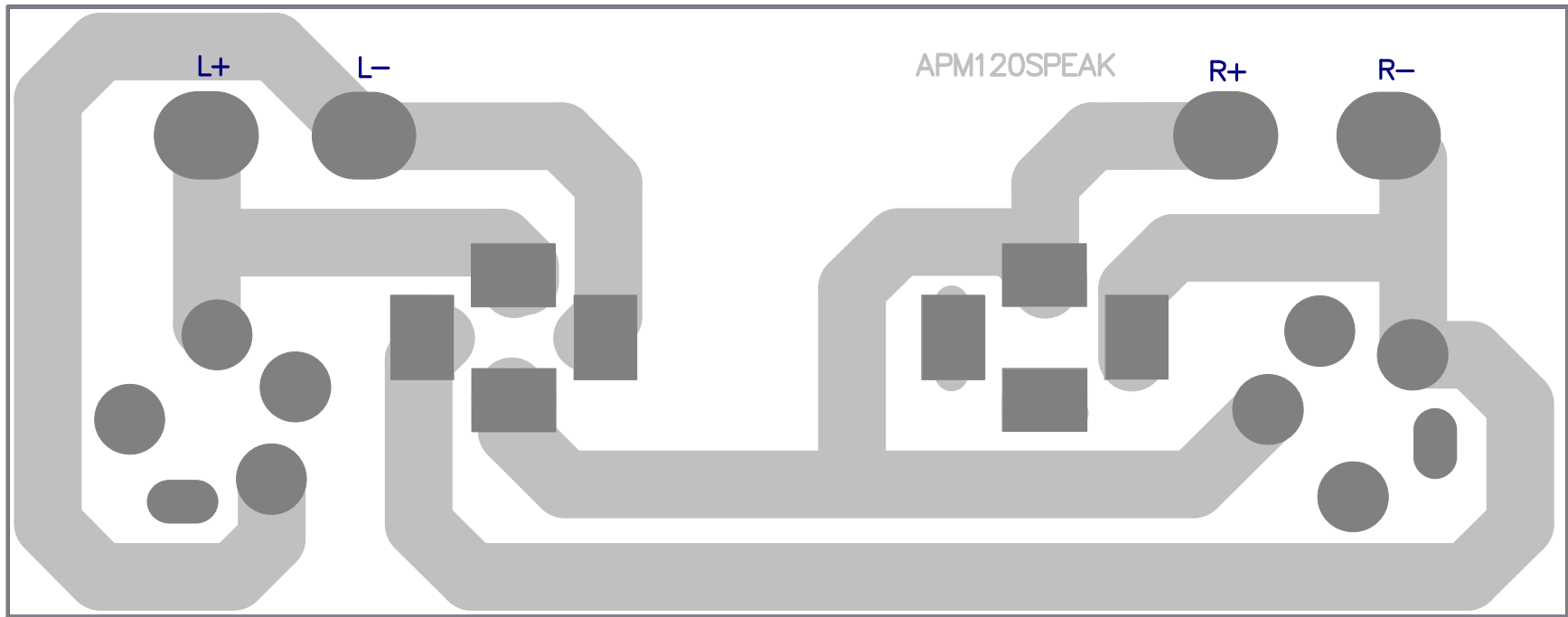

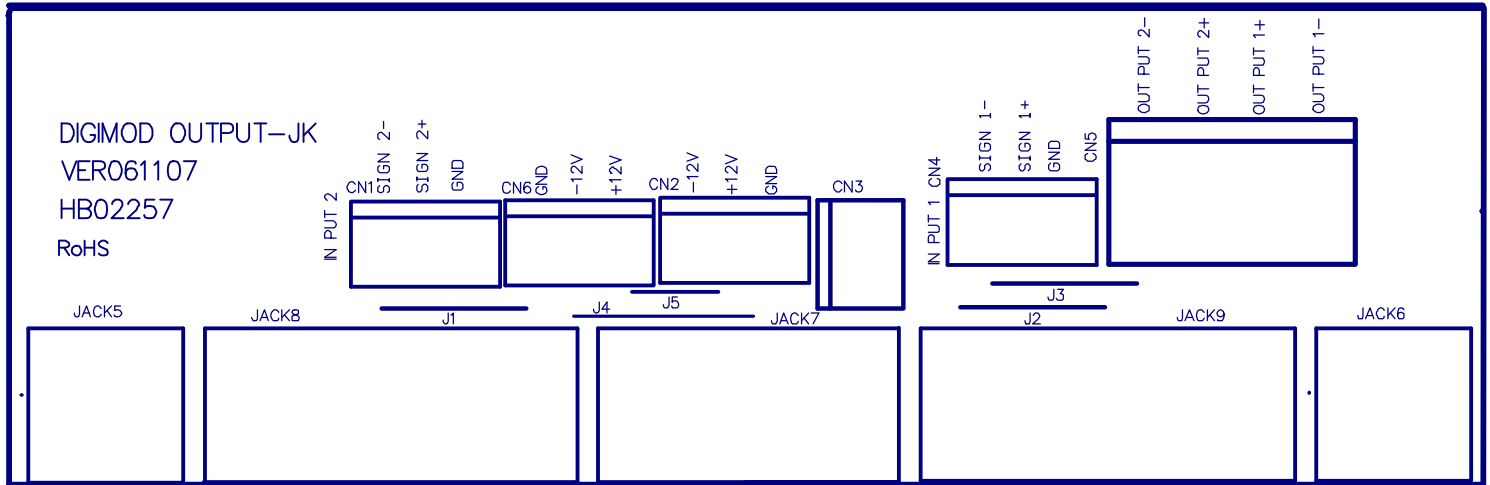
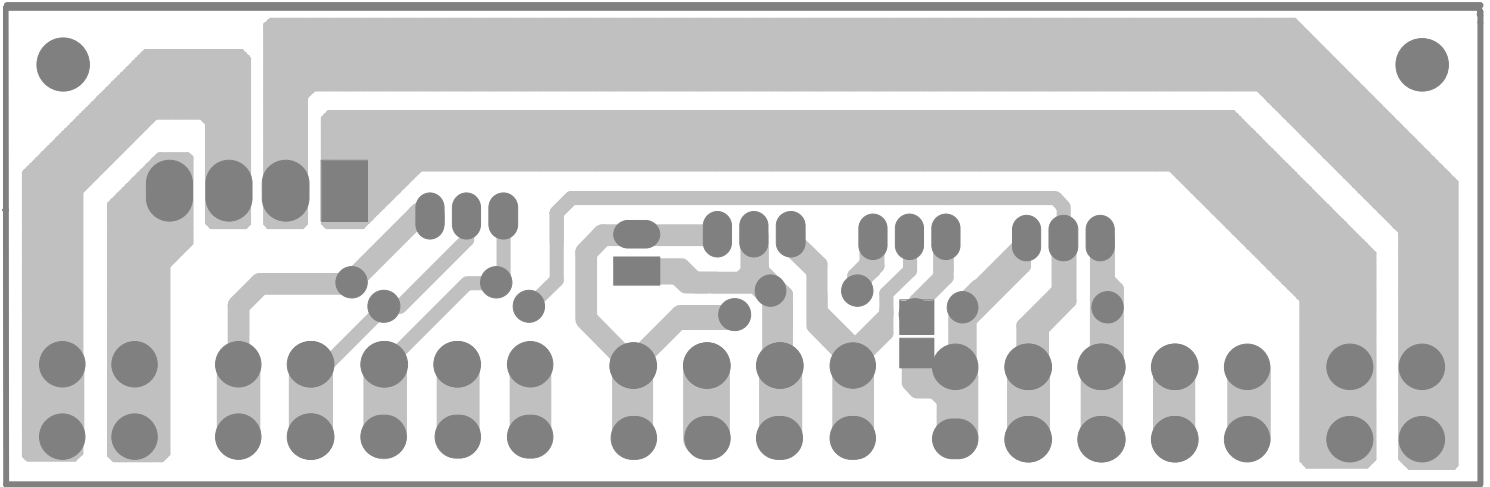

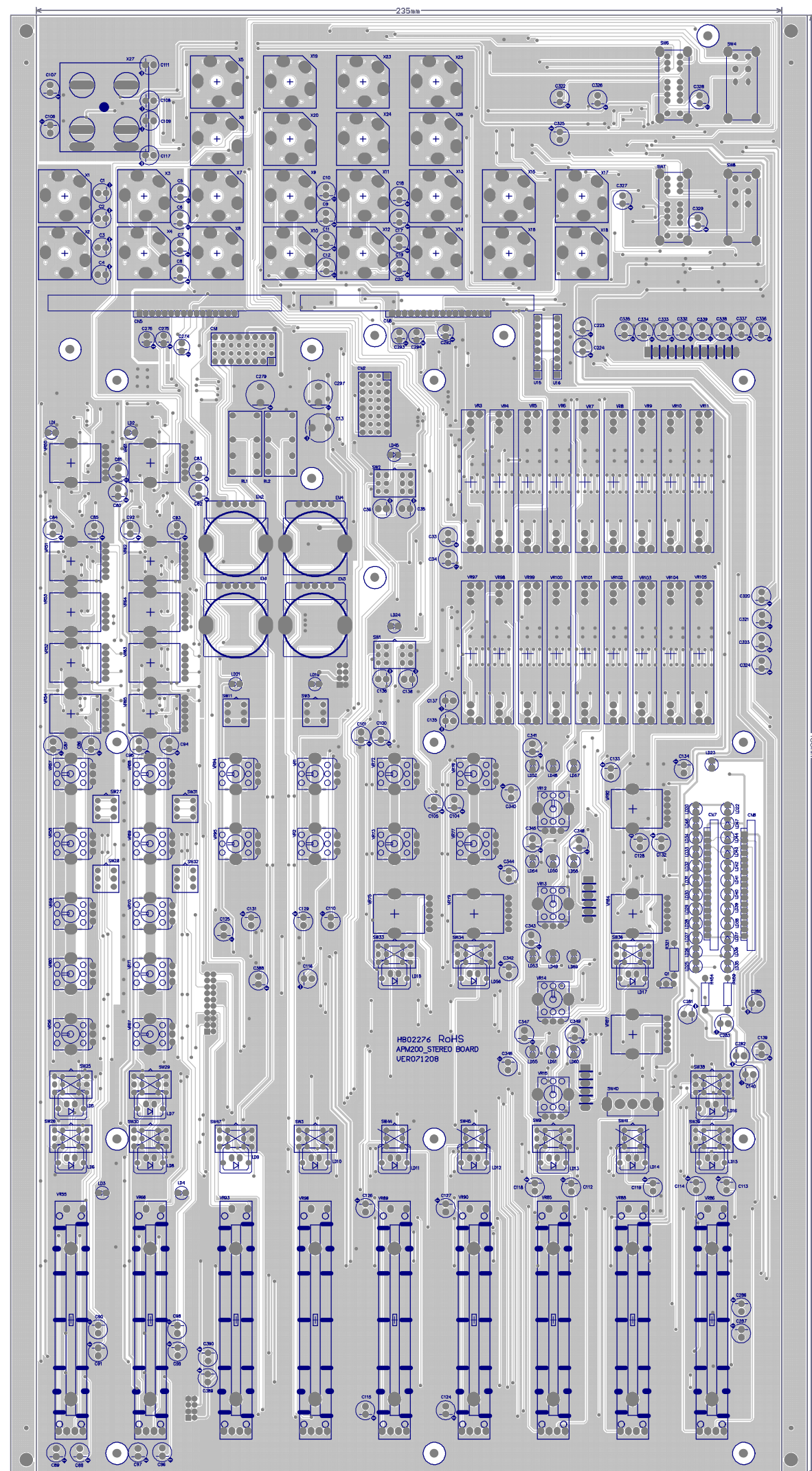
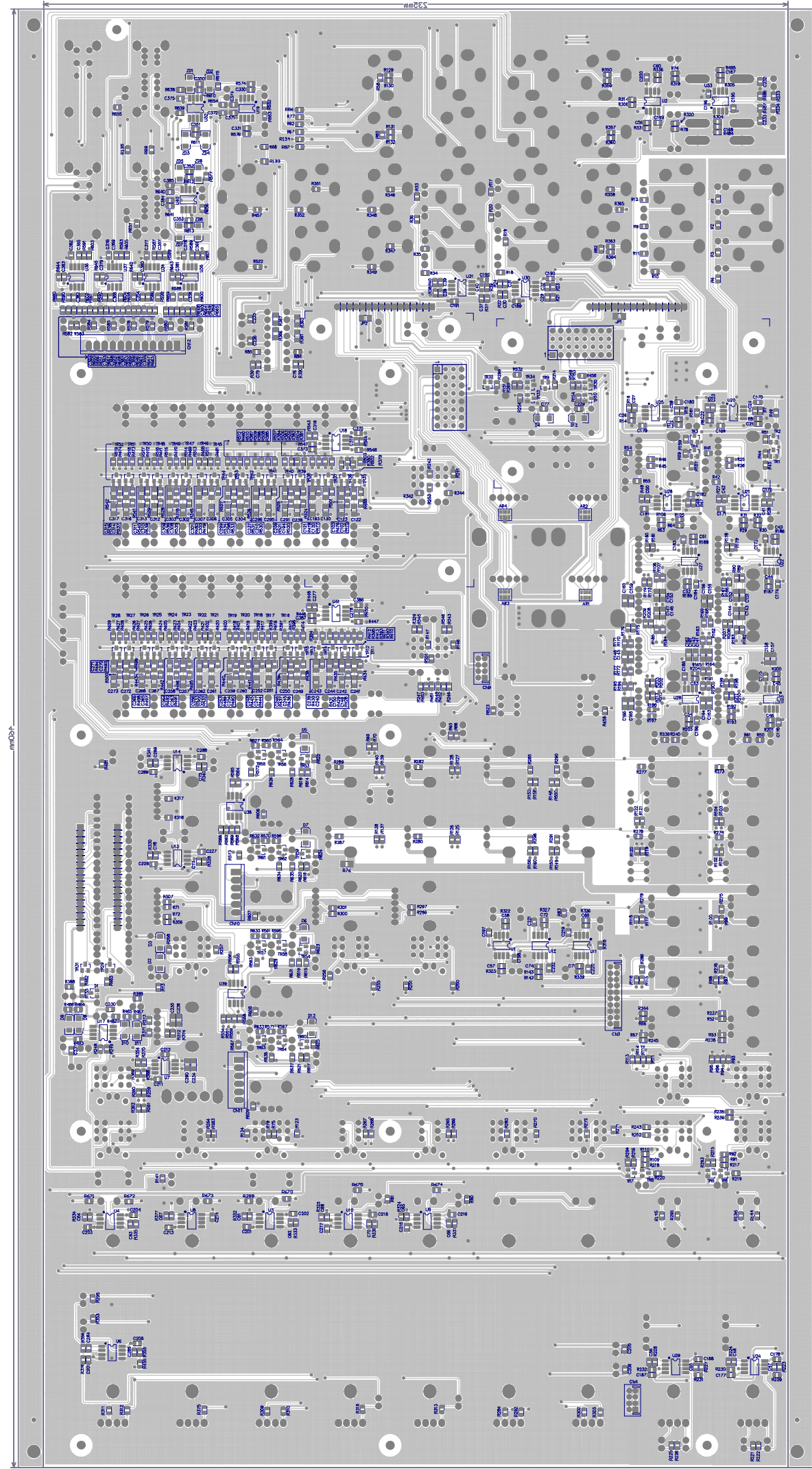

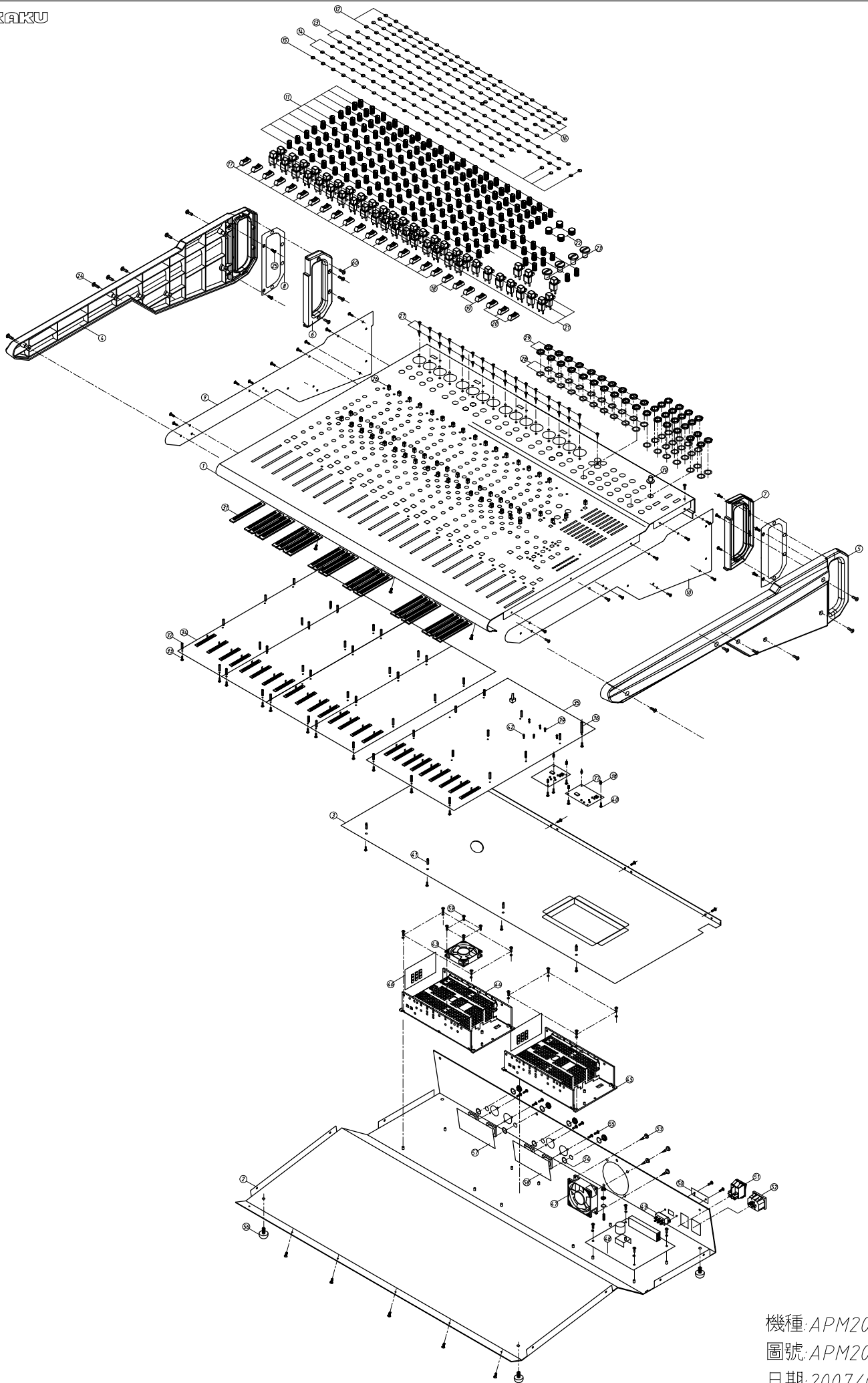

No.	Part No.	Description	Specification	PCS
1	MA07116	PANEL	APM200 ALTO-V1.0	1
2	MB05627	BOTTOM REAR PANEL	APM200 ALTO-V1.0	1
3	MI03912	BARRIER	APM200 0.8t*484.48*640*10-V1.0	1
4	NI04461	HANDLE	APM-120 25.5*134.3*559BLACK RIGHT-V1.0	1
5	NI04460	HANDLE	APM-120 25.5*134.3*559BLACK LEFT- V1.0	1
6	NI04463	HANDEL COVER	APM-120 12*58.47*134.3BLACK RIGHT-V1.0	1
7	NI04462	HANDEL COVER	APM-120 12*58.47*134.3BLACK LEFT- V1.0	1
8	MI03815	CUSHION	APM-120 1.5t*61.5*123*128-V1.0	2
9	MI03811	SIDE BOARD	APM-120 0.8t*129.57*505 RIGHT-V1.0	1
10	MI03813	SIDE BOARD	APM-120 0.8t*129.57*505 LEFT-V1.0	1
11	NI04004	RUBBER BUTTON	10*16.5	192
12	NI01147	BUTTON COVER	7*3.5 WHITE V1.4	34
13	NI04601	BUTTON COVER	7*3.5 3298U GREEN-V1.0	44
14	NI04602	BUTTON COVER	7*3.5 123U YELLOW-V1.0	36
15	NI02692	BUTTON COVER	7*3.5 BLACK	22
16	NI02678	BUTTON COVER	7*3.5 534C BLUE	56
17	NI03701	SLIDE SWITCH	24*9.5*10.5-V1.3	18
18	NI03055	SLIDE SWITCH	24*9.5*10.5 TYPHOON-V1.0	2
19	NI03056	SLIDE SWITCH	24*9.5*10.5 TYPHOON	2
20	NI03403	SLIDE SWITCH	24*9.5*10.5 TYPHOON	3
21	NI02926	LIGHT-PASS SWITCH	13.9*10*24mm	47
22	NI02386	RUBBER BUTTON	14*13mm	4
23	NI00360	RUBBER BUTTON	15*15mm	4
24	MG00027	BLACK-PLATED SCREW	M3*12	14
25	MG00045	BLACK-PLATED SCREW	M3*7	4
26	NI03140	BUTTON COVER	5*5*9 TYPHOON-V1.0	56
27	MG00061	BLACK-PLATED ZINC SCREW	M3*10	33
28	MF00061	WASHER	9.6* 13*0.5t	60
29	ME00060	SCREW NUT	JY-6351g-02-250	60
30	HC00206	BNC CONNECTOR	WJ-7031	1
31	NI04090	FIXED PLATE	3.5*47*81 BLACK-V1.0	25
32	MG00645	COPPER PILLAR	M3*16*0.5PH-V1.0	44
33	MG00041	BLACK-PLATED SCREW	M3*6	130
34	HK07692	K-PC BOARD	P-APM120 MONO-DIP	4

No.	Part No.	Description	Specification	PCS
35	HK07698	K-PC BOARD	P-APM200 STEREO-DIP	1
36	MG00305	COPPER PILLAR	M3*24*0.5PH	1
37	HK01409	K-PC BOARD	P-313123-DIP	2
38	MG00243	COPPER PILLAR	M3*5*0.5PH	6
39	MF00037	SPRING WASHER	3.2* 5.5*1t	18
40	MG00036	BLACK-PLATED SCREW	M3*4	6
41	MG00572	COPPER PILLAR	M3*125*0.5PH	4
42	ME00015	COLOR NUT	3mm	6
43	HE00125	FAN	DC24V/0.14A 80*80*15.175mm	1
44	HK07846	K-PC BOARD	P-DIGIMOD 1500-DIP	1
45	HK07847	K-PC BOARD	P-DIGIMOD 1000-DIP	1
46	HK07707	K-PC BOARD	P-APM120-OUTPUT CN	2
47	HE00113	FAN	DC24V/67mA 80*80*25mm 125mm	1
48	HK07395	K-PC BOARD	P-PSM-50Wd-DIP	1
49	HI00120	SLIDE SWITCH	L21-22A	1
50	NI03205	PROTECTION COVER	0.5*44*15-V1.0	1
51	HC00331	AC CONNECTOR	RF-2004	1
52	HI00022	POWER SUPPLY	4P R13-69A	1
53	MG00268	NIKEL SCREW	M5*12	4
54	NC00131	WOODEN WASHER	1* 11.3* 15.3	4
55	MG00057	BLACK-PLATED SCREW	M3*8	8
56	NI04569	ADHESIVE RUBBER FOOT	M6* 23.5*20.5mm	4
57	HK07709	K-PC BOARD	P-APM120SPEAK	1
58	HK09187	K-PC BOARD	P-APM20SPEAK	1
59	MG00489	BLACK-PLATED SCREW	M3*20	4
60	MG00063	BLACK-PLATED SCREW	M3*12	8

Rank	Part No.	Description	Specification	QTY	Remark
PF03306		MIXER	APM200 ALTO 230V	1	
0001	MA07116	panel-RS	APM200 ALTO V1.1	1	
0002	MB05627	chassis-RS	APM200 ALTO V1.1	1	
0003	MI03813	side cover board-RS	APM-120_V1.0	1	
0004	MI03811	side cover board-RS	APM-120 1t*129.57*505 right V1.0	1	
0005	MI03912	barrier-RS	APM200 0.8t*247.8*655*10 V1.1	1	
0006	NI04460	handle-RS	APM-120 25.5*134.3*559 V1.0	1	
0007	NI04461	handle-RS	APM-120 25.5*134.3*559 V1.0	1	
0008	MI03815	caushion-RS	APM-120 1.5t*61.5*123*128 V1.1	2	
0009	NI04462	handle cover-RS	APM-120 12*58.47*134.3 V1.0	1	
0010	NI04463	handle cover-RS	APM-120 12*58.47*134.3 V1.0	1	
0011	HA00861	power cord Europe 3P	LT-312+LT-501	1	
0012	NI04004	knob	10*16.5 90° V1.0	192	
0013	NI01147	knob cover-RS	7*3.5 V2.1	34	GAIN , EQ/FREQ
0014	NI02678	knob cover	7*3.5 534C blue	56	EQ HI , MID , LOW
0015	NI02692	knob cover	7*3.5 black	22	PAN , BAL , ST SUB IN , 2TR IN , PHONES , ST SUB OUT
0016	NI04601	knob-RS	7*3.5 3298U V1.0	44	AUX1 , AUX2
0017	NI04602	knob-RS	7*3.5 123U V1.0	36	AUX3 , AUX4
0018	NI02386	konb-RS	14*13mm	4	DSP
0019	NI00360	knob-RS-C	15*15mm V1.2	4	AMP LEVEL
0020	NI03701	knob-RS-C	24*9.5*10.5 V1.4	18	CH LEVEL 1to20
0021	NI03055	knob-RS-C	24*9.5*10 TYPHOON 187 V1.1	2	EFFECT RTN
0022	NI03056	knob-RS-C	24*9.5*10 TYPHOON 282 V1.1	2	AUX1 , AUX
0023	NI03043	knob-RS-C	24*9.5*10 TYPHOON V1.1	3	MONO OUT,ST OUT , ST SUB
0024	NI02926	button	13.9*10*24mm TYPHOON V1.4	47	
0025	NI03140	knob-RS-C	5*5*9 TYPHOON V1.1	56	
0026	NI04090	fixed board	TYPHOON1600 3.5*47*81 black V1.0	25	
0027	HC00206	BNC jack	WJ-7031(28*12.7)	1	
0028	MG00041	screw	M3*6	130	PCB*90,bottom rear panel10,AMP module*8. side boards*18
0029	MG00025	screw-RS	M3*6	4	barrier*4
0030	MG00268	screw	M5*12	4	fan
0031	HE00125	fan-RS	DC24V/0.14A 80*80*15 175mm JST2P	1	DIGIMOD1500
0032	MG00489	screw	M3*20	4	DIGIMOD1500
0033	MG00027	screw	M3*12	14	left handle*6,right handle*6,lock AC select switch *2
0034	MG00063	screw	M3*12	8	lock left handle cover*4,lock right handle cover*4
0035	MG00045	screw	M3*7	4	left handle cushion*2 , right handle cushion*2
0036	MG00061	screw-RS	M3*10	33	MIC connector*32,RCA connector*1
0037	MG00057	screw	M3*8	8	speaker connector
0038	MG00243	copper pillar	M3*5*0.5PH	6	313123module
0039	MG00572	copper pillar	M3*12.5*0.5PH 17mm 9mm	4	barrier
0040	MG00645	copper nut	M3*16*0.5PH V1.0	44	
0041	MG00305	copper pillar	M3*24*0.5PH	1	
0042	MG00036	screw	M3*4	6	313123module*3
0043	ME00015	color nut	3m/m	6	313123module

Rank	Part No.	Description	Specification	QTY	Remark
0044	ME00060	MIC jack	JY-6351G-02-250	60	panel*56 , rear panel*4
0045	MF00061	MIC jack	9.6* 13*0.5t	60	panel*56 , rear panel*4
0046	HI00120	slide switch	L21-22A	1	DIGIMODvoltage select switch
0047	NI00268	sleeve	6*20mm	4	power supply switch
0048	NI00261	sleeve	5*20mm	2	AC connector
0049	NI00252	sleeve	4*20mm	5	Ac select switch*4,BNC connector*1
0050	NI03205	protective cover	0.5*44*15 V1.0	1	AC select switch
0051	NI05048	wire sleeve-RS	5.3*50mm	2	
0052	NI05129	wire sleeve-RS	5.3*72mm	1	
0053	HC00876	terminal block-RS	7ESDP-02P	4	DIGIMOD
0054	HI00022	power switch-RS	4p black frame red key	1	
0055	HC00331	AC socket	RF-2004	1	
0056	HD00098	glass tube fuse	T6.3A 250V 5.2*20mm CCC/BSI/C-UR/VDE	2	DIGIMOD1500*1
0057	HD00105	glass tube fuse- slow(spiral)	4A 250V 5.2*20mm CSA/CCC/UL/VDE	1	DIGIMOD1000
0058	HA00360	wire	80mm grey L5R5	1	AC IN TO AC SW
0059	HA00565	wire	80mm white L5R5	1	AC IN TO AC SW
0060	HA00431	wire-RS	90mm blue L5R5	2	DIGIMOD1000voltage select switch
0061	HA00542	wire	320mm red L5R5	2	DIGIMOD1500voltage select switch
0062	HA00459	wire	180mm blue L5R5	1	DIGIMOD1000power input
0063	HA00527	wire	180mm red L5R5	1	DIGIMOD1000power input
0064	HA00477	wire	420mm brown L5R5	1	DIGIMOD1500power input
0065	HA00550	wire	420mm red L5R5	1	DIGIMOD1500power input
0066	HA04830	wire-RS	20P*5 110*3/95mm UL1007 28AWG	1	APM200 BUS
0067	HA04856	wire-RS	8P-4P*2 760/110*6/450/280/70UL1007 28AWG	1	200 PWR
0068	HA05019	wire-RS	2P/1P 230mm UL1007 24AWG	1	BNC connector
0069	HA04941	wire-RS	3P 70mm UL1015 18AWG	1	PSM50WD power input
0070	HA04878	wire-RS	130/110mm UL1015 18AWG	1	ground,DIGIMOD1000
0071	HA05124	wire-RS	8P/6P-6P 800mm UL1007 24AWG	1	DIGIMOD1500signal LED
0072	HA05123	wire-RS	8P/6P-6P 580mm UL1007 24AWG	1	DIGIMOD1000signal LED
0073	HA05121	wire-RS	12P-3P*2/3P*2 550/800mmUL1007 24AWG	1	DIGIMOD1000,1500signal input
0074	ND00151	silicone sleeve-RS- ACT	12*220mm	1	
0075	HC00034	short circuit connector	NO.2700 2.54mm/6mm OPEN	1	power boardJ2
0076	NI04282	header fixe bracket-RS	FCN-15(3M)	1	
0077	NI00218	cable tie	ALT-102SB	4	
0078	NC00131	washer	1* 11.3* 15.3 red	4	AMP output MIC connector
0079	MF00038	washer-RS	4* 7*1t	1	fixed ground
0080	MF00048	washer-RS	4* 8*0.5t	1	fixed ground
0081	ME00016	color nut	4m/m	1	fixed ground
0082	MF00014	washer	3* 6.5*0.5t	4	fixed power supply board
0083	MF00037	washer	3.2* 5.5*1t	18	power supply board,DIGIMOD.313123module
0084	NI04569	rubber cushion-RS	M6* 23.5*20.5mm black	4	
0085	NA00882	PE bag-RS	0.03t*1050*680mm 12 hole V1.0	1	
0086	NA00279	clip-chain bag	0.04t*100*150mm V1.0	1	warranty
0087	AD00012	twin adhesive-RS	90*120mm V1.0	1	
0088	NF00061	assurance card-RS- C	ALTO_V1.1	1	

Rank	Part No.	Description	Specification	QTY	Remark
0089	HJ00006	dessicant	30g	1	
0090	NE05004	label	ALTO PF V1.2	4	
0091	NE16531	lable-RS	APM200 V1.0	4	
0092	NB05604	carton-RS	APM200 ALTO V1.0	1	
0093	NB05603	inner case-RS	APM200 ALTO V1.0	1	
0094	NA00746	silk wadding-RS	APM200 up V1.0	1	
0095	NA00747	silk wadding-RS	APM200 down V1.0	1	
0096	HK01409	PC board-RS	P-313123-DIP(AMX-140FX)	2	
0001	SC00004	crystal oscillator	16.00MHZ	1	
0002	HC00484	connector	2.54 180° 2*8P(gold-plated) 13.5/19mm	1	
0003	SG00193	SMD integrated circuit	SST39VF010-70n/L-8	1	
0004	HK03894	PC board-RS-ACT	P-313123-SMD(L-8)	1	
0001	HB00895	PCB	313123/2(1*6)	1	
0002	CI00075	SMD ceramic capacitor 0603	0.1uF/50V Y5V +80,-20%	13	
0003	RD00061	SMD fixed resistor 1/10W	10 ±5% 0603	1	
0004	RD00068	SMD fixed resistor 1/10W	100 ±5% 0603	8	
0005	RD00073	SMD fixed resistor 1/10W	220 ±5% 0603	1	
0006	RD00085	SMD fixed resistor 1/10W	1.5K ±5% 0603	10	
0007	RD00088	SMD fixed resistor 1/10W	2.2K ±5% 0603	8	
0008	RD00101	SMD fixed resistor 1/10W	10K ±5% 0603	3	
0009	RD00125	SMD fixed resistor 1/10W	1.0M ±5% 0603	1	
0010	RE00006	SMD resistor networks 1/16W	100 *4 ±5% 8P 1206(0603x4)	2	
0011	SE00011	SMD rectifier diode	RLS4148 0.5A (LL-34)	1	
0012	SG00068	SMD integrated circuit	74HC14DT(SO14)/(PHI)	1	
0013	SG00410	SMD integrated circuit-RS-ACT	IC41LV16256-35KG(SQJ40)/(ICSI)	1	
0014	SG00166	SMD integrated circuit	TY-2 ALTO(GMCODE:105022)	1	
0015	SG00037	SMD integrated circuit	LD1117DT33C(TO252)/(ST)	1	
0016	HC00611	IC socket (SMD)	PLCC32 (AMP S/N:822516-	1	
0017	SG00016	SMD integrated circuit	UDA1345TS(SSOP28)/(PHI)	1	
0018	AE00449	solder material without lead	9308/Sn Ag Cu	0.3864	
0019	CI00264	SMD ceramic capacitor-RS 0603	15PF/50V NPO ±5 %	2	
0005	NE11475	label	L-8	1	
0001	NH00035	bond paper	0.06*1M	1	
0002	NI00016	membrane	0.05*1M	1	
0006	AC00179	tin without lead-RS	M705E Sn 3Ag-0.5Cu	5.058	
0007	CB00166	electrolytic capacitor	100uF/16V 6*5mm	11	
0097	HK07846	PC board	P-DPSAMP1500(APM160)-DIP	1	
0001	SD00066	integrated circuit	L7812CV(TO220)/(ST)	1	
0002	NI00280	sleeve	15*25mm	1	
0003	MG00161	screw	M3*6	2	

Rank	Part No.	Description	Specification	QTY	Remark
0004	HC00359	connector	2.54 180° 4P(gold-plated) 6/11.6mm	2	
0005	HC00389	connector(male)	16P 2.54mm180°	1	
0006	HC00082	connector(male)	8P 2.5mm 180°	1	
0007	HD00018	glass tube fuse	6.3A 250V 5.2*20mm CCEE/CSA/S/UL/VDE	1	
0008	HC00276	connector(male)	3P 2.54mm 180°	2	
0009	HC00034	short circuit connector	NO.2700 2.54mm/6mm OPEN	4	
0010	CF00016	metal-film capacitor MSC	0.01uF/100V 5% CASE01	1	
0011	HA01919	jump	5mm	1	
0012	CB00038	electrolytic capacitor	47uF/16V 5*7mm	2	
0013	MK00115	spring-RS	1.0T*7.6*13*34.2(ML00004) V 1.3	8	
0014	MC00801	top cover-RS-ACT	DigiMod 1.0t*48*116*136.8(ME00015 6) V1.4	1	
0015	HC00859	terminal block-RS	2P 2EHDV-02P male	2	
0016	HC00858	terminal block-RS	2P 2EHDV-02P male	2	
0017	HC00857	terminal block-RS	4P 2EHDV-04P male	1	
0018	HC00856	terminal block-RS	5P 2EHDV-05P male	2	
0019	HC00866	row-wire header- RS-ACT	72P 1.27mm 180° (AMP:5822021-4)	1	
0020	NC00980	Silicone insulator- RS	1.0t*25mm*30mm	1	
0021	CN00180	common inductance-RS	1.90uH~2.30uH/T50- 2(TO000061)	2	
0022	SD00318	integrated circuit- RS-C	TC4423EPA(PDIP8)/(MICRO CHIP)	5	
0023	SD00317	integrated circuit	NJM7912FA(TO220F)/(JRC)	1	
0024	AC00179	tin without lead-RS	M705E Sn 3Ag-0.5Cu	23.94	
0025	RA01620	cement resistor-RS	4.7 5% SQM/(TYCO P/N:1-1623788-6)	2	
0026	MG00692	screw-RS	M3*12*0.5PH	11	
0027	ME00226	screw-RS	M3*0.5PH	11	
0028	MG00694	screw-RS	M2.9*9.5	6	
0029	MG00693	screw-RS	M3*6*0.5PH	8	
0030	SA00316	bridge rectifier-RS	8A GBU-8K/(PANJIT)	1	
0031	NE16112	lable	K-SERIES V1.0	1	
0032	NC01179	insulator spacer-RS	0.13t*40mm*55mm(HI- FLOW-625)	3	
0033	NI04389	plastic washer-RS	TW-20N	2	
0034	SB00221	transistor-RS-CT	BD237(SOT32)/(ST)	1	
0035	SB00222	transistor-RS-CT	HGTG12N60A4D(TO247)/(F AIRCHLD)	2	
0036	RA01654	wirewound resistor 5W	0.1 ± 5%/(AC05000001007JAC00)	4	
0037	RH00032	thermistor-RS-NTC	10K± 5%(NTCLE100E3103JB0)	2	
0038	SB00227	Pohtotriode-RS	CNY17F2M(DIP6)/(FAIRCHI LD)	1	
0039	CN00200	common inductance-RS-CT	2.3mH/4A EV28-4.0-02- 2M3/(SCHAFFNER)	2	
0040	RA01659	metal-oxide-film resistor-RS 1/2W	240K ±5% VR37(VR37000002403JA100)	1	
0041	SB00228	transistor-RS	MURF1660CTG(TO220)/(ON	3	

Rank	Part No.	Description	Specification	QTY	Remark
0042	CG00081	Y-type capacitor-RS-ACT	S20-K300(B72220301K101)/(EPCOS)	1	
0043	RH00034	thermistor-RS-CT	2.5 B57237S259M/(EPCOS)	1	
0044	HK07313	PC board	P-DGM1500(PowerSoft)-	1	
0001	CI00046	SMD ceramic capacitor 1206	1uF/16V Y5V-1206(3216)	23	
0002	CI00095	SMD ceramic capacitor 1206	0.1uF/50V X7R	4	
0003	CI00103	SMD ceramic capacitor 1206	100PF/50V NPO ±5%	1	
0004	CI00041	SMD ceramic capacitor 1206	470PF/50V NPO	1	
0005	CI00042	SMD ceramic capacitor 1206	0.001uF/50V NPO	12	
0006	CI00263	SMD ceramic capacitor-RS 1206	0.0047uF/200V X7R ±10%	6	
0007	CI00135	SMD ceramic capacitor 1206	33PF/50V NPO ±5%	1	
0008	SE00097	SMD diode-RS-CT	1A/400V US1G(DO214AC)/(VISHAY)	7	
0009	SE00095	SMD diode-RS-CT	ES3D(DO214AB)/(VISHAY)	3	
0010	SE00025	SMD diode-RS	0.45A/85V BAV99	5	
0011	SE00089	SMD zener diode-RS	1/2W 5.1V(MMSZ5231B)(SOD-123)/(PANJIT)	4	
0012	SG00495	SMD integrated circuit-RS	IR2156SPBF(SO14)/(IR)	1	
0013	SG00465	SMD integrated circuit-RS	M24C16WMN6TP(SO8)/(ST)	1	
0014	SG00466	SMD integrated circuit-RS-ACT	HCPL-0611#060(SO8)/(AGILENT)	4	
0015	SF00101	voltage stabilized transistor-RS	L4941BDT-TR-PB FREE(DPAK)/(ST)	1	
0016	RD00245	SMD precise resistor 1/4W	1.00K ±1% 1206	7	
0017	RD00140	SMD fixed resistor 1/4W	4.7K ±5% 1206	1	
0018	RD00399	SMD precise resistor 1/4W	10.0K ±1% 1206	4	
0019	RD00255	SMD precise resistor 1/4W	100K ±1% 1206	14	
0020	RD00615	SMD precise resistor-RS 1/8W	1.50 ±5% 0805	3	
0021	RD00607	SMD precise resistor-RS 1/4W	330 ± 1% 1206	12	
0022	RD00606	SMD precise resistor-RS 1/4W	15.0 ± 1% 1206	2	
0023	RD00605	SMD precise resistor-RS 1/4W	4.70 ± 1% 1206	4	
0024	RD00604	SMD precise resistor-RS 1/4W	47.0 ± 1% 1206	1	
0025	AE00449	solder material without lead	9308/Sn Ag Cu	0.456	
0026	CI00279	SMD ceramic capacitor-RS 1206	0.0022uF/200Vx7R±10%	1	
0027	SE00098	SMD zener diode-RS-C	1W 15V DL4744A MELF/(SJ)	2	

Rank	Part No.	Description	Specification	QTY	Remark
0028	CO00138	SMD fixed inductance-RS-CT	4*0.47mH(B82792-C2474-N315/(EPCOS)	1	
0029	HB02847	PCB-RS	DPSAMP1000 VER080319	1	
0030	RD00635	SMD precise resistor-RS 1/4W	33.0K ±1% 1206	1	
0045	HK07198	PC board-RS	P-DGMFILT14(TO000062)	2	
0001	HC00855	connector-RS	2.54 90° 2*2P (gold-plated) 6/14.4/19.5	2	
0002	AC00179	tin without lead-RS	M705E Sn 3Ag-0.5Cu	0.252	
0003	NI00218	cable tie	ALT-102SB	1	
0004	CN00179	common inductance-RS	25.344uH±10%/T130-2(TO000062)	1	
0005	HB02845	PCB-RS	DPSAMP1000FILT(2*3)_VE R080319	1	
0046	SB00231	transistor-RS	IRFP264PBF(TO-	4	
0047	TC00380	transformer-RS	EE42/20(TO000082)	1	
0001	NI04468	creel stand-RS-ACT	FE0252(MILES PLATTS)	1	
0002	TC00387	transformer-RS	EE42/20(TO000082)	1	
0048	HK07314	PC board	P-DGM500-1000/CNTRL17(DGM1500)-DIP	1	
0001	SC00319	crystal oscillator	12.288MHZ	1	
0002	AC00179	tin without lead-RS	M705E Sn 3Ag-0.5Cu	0.5	
0003	HK07274	Photodiode	P-photosensitive resistance+ 3Iled	2	
0001	RH00020	photosensitive resistance	VT90N1	1	
0002	SA00305	L.E.D-RS	3 circle red high intensity	1	
0003	NI02405	sleeve	5*15mm	1	
0004	HK07315	PC board	P-DGM500-1000/CNTRL17(DGM1500)-SMD	1	
0001	CI00201	SMD ceramic capacitor 0603	0.01uF/50V ± 10%(C1608X7R1H103KT)/TDK	4	
0002	CI00185	SMD ceramic capacitor 0603	0.1uF/50V X7R± 10%(C1608X7R1H104KT)/TDK	25	
0003	CI00220	SMD ceramic capacitor 0603	220PF/50V C0G ± 5%(C1608C0G1H221JT)/TD	3	
0004	CI00234	SMD ceramic capacitor 0603	0.0033uF/50VC0G± 5%(C1608C0G1H332JT)/TD	1	
0005	CI00228	SMD ceramic capacitor 0603	0.001uF/50V C0G± 5%(C1608C0G1H102JT)/TD	4	
0006	CI00222	SMD ceramic capacitor 0603	330PF/50V C0G ± 5%(C1608C0G1H331JT)/TD	4	
0007	CI00224	SMD ceramic capacitor 0603	470PF/50V C0G ± 5%(C1608C0G1H471JT)/TD	6	
0008	CI00083	SMD ceramic capacitor 0603	3.9PF/50VC0G± 0.25PF(C1608C0G1H3R9CT)TDK	2	
0009	CI00216	SMD ceramic capacitor 0603	82PF/50V C0G ± 5%(C1608C0G1H820JT)/TD	4	
0010	CI00053	SMD ceramic capacitor 0603	33PF/50V C0G± 5%(C1608C0G1H330JT)/TD	2	
0011	CI00105	SMD ceramic capacitor 1206	0.0022uF/50V NPO ±5%	2	

Rank	Part No.	Description	Specification	QTY	Remark
0012	CI00125	SMD ceramic capacitor 1210	10uF/16V Y5V-1210(3225)	5	
0013	CI00084	SMD ceramic capacitor 0603	4.7PF/50VC0G± 0.25PF(C1608C0G1H4R7CT) TDK	1	
0014	SE00025	SMD diode-RS	0.45A/85V BAV99	4	
0015	SE00026	SMD diode-RS	0.45A/85V BAV70	7	
0016	SE00027	SMD diode-RS	0.45A/85V BAW56	5	
0017	SE00090	SMD zener diode-RS	1/2W 6.8V(MMSZ5235B)(SOD-123)/(PANJIT)	4	
0018	SG00502	SMD integrated circuit-RS	NE5532DR(SO8)/(TI)	4	
0019	SG00496	SMD integrated circuit-RS	LF412CDR(SO8)/(TI)	2	
0020	SG00045	SMD integrated circuit	BU4081BF(SOT73)/(PHI)	1	
0021	SG00509	SMD integrated circuit-RS	HEF4069UBT(SO14)/(PHI)	2	
0022	SG00001	SMD integrated circuit	TL074CDT(SO14)/(ST)	2	
0023	SE00077	SMD L.E.D-RS	red KPTC-2012EC	2	
0024	SE00078	SMD L.E.D-RS	green KPTC-2012SGC	3	
0025	CO00137	SMD inductance-RS	1.0mH ±5%(NL453232T-102J)/(TDK)	2	
0026	RD00298	SMD precise resistor 1/10W	47.0 ±1% 0603	11	
0027	RD00214	SMD precise resistor 1/10W	10.0K ±1% 0603	45	
0028	RD00282	SMD precise resistor 1/10W	1.00K ±1% 0603	20	
0029	RD00224	SMD precise resistor 1/10W	100K ±1% 0603	10	
0030	RD00506	SMD precise resistor 1/10W	3.30K ±1% 0603	8	
0031	RD00399	SMD precise resistor 1/4W	10.0K ±1% 1206	4	
0032	RD00320	SMD precise resistor 1/4W	12.0K ±1% 1206	4	
0033	RD00201	SMD precise resistor 1/10W	1.50K ±1% 0603	5	
0034	RD00292	SMD precise resistor 1/10W	1.00M ±1% 0603	9	
0035	RD00392	SMD precise resistor 1/10W	2.20K ±1% 0603	7	
0036	RD00322	SMD precise resistor 1/10W	2.70K ±1% 0603	14	
0037	RD00301	SMD precise resistor 1/10W	12.1K ±1% 0603	2	
0038	RD00218	SMD precise resistor 1/10W	15.0K ±1% 0603	6	
0039	RD00339	SMD precise resistor 1/10W	47.0K ±1% 0603	8	
0040	RD00390	SMD precise resistor 1/10W	10.0M ±1% 0603	2	
0041	RD00592	SMD precise resistor-RS 1/10W	10.0K ±0.1% 0603	8	

Rank	Part No.	Description	Specification	QTY	Remark
0042	RD00591	SMD precise resistor-RS 1/10W	82.0K ±0.1% 0603	4	
0043	RD00332	SMD precise resistor 1/10W	680 ±1% 0603	2	
0044	RD00525	SMD precise resistor 1/10W	33.0K ±1% 0603	2	
0045	RD00590	SMD precise resistor-RS 1/10W	1.50K ±0.1% 0603	4	
0046	RD00129	SMD fixed resistor 1/4W	0.0 ±5% 1206	2	
0047	RD00342	SMD precise resistor 1/10W	1.50M ±1% 0603	2	
0048	RD00105	SMD fixed resistor 1/10W	22K ±5% 0603	1	
0049	RD00509	SMD fixed resistor 1/10W	24K ±5% 0603	1	
0050	SF00030	SMD transistor-RS-ACT	BC817(SOT23)/(PHI)	2	
0051	AE00449	solder material without lead	9308/Sn Ag Cu	1.8276	
0052	CI00278	SMD ceramic capacitor-RS 1206	0.0018uF/50V NPO ±5%	2	
0053	CI00225	SMD ceramic capacitor 0603	560PF/50V C0G ±5%(C1608C0G1H561JT)/TD	2	
0054	RD00415	SMD precise resistor 1/10W	4.70K ±1% 0603	6	
0055	HB02848	PCB-RS	DPSAMP1000CTRL(1*5)_V ER080319	1	
0056	SG00661	SMD integrated circuit-RS	ATmega8-16AU(TQFP32)/(ATMEL) CS:001F9B76	1	
0005	NE16833	lable-RS	DIGIMOD1000 V1.0	1	
0001	NI00018	membrane	0.06*1M	1	
0002	NH00035	bond paper	0.06*1M	1	
0006	NE16888	lable-RS	DIGIMOD1500 V1.0	1	
0001	NI00018	membrane	0.06*1M	1	
0002	NH00035	bond paper	0.06*1M	1	
0007	NE16885	lable-RS	DIGIMOD1500(SM381) V1.	1	
0001	NI00016	membrane	0.05*1M	1	
0002	NH00014	bond paper	0.05*1M white	1	
0049	NE16887	lable-RS	POWERMOD V1.0	1	
0001	NI00015	membrane	0.04*1M	1	
0002	NH00014	bond paper	0.05*1M white	1	
0050	HC00941	fuse drawer-RS-ACT	520101(5.2mm) PCB式 LITTLEFUSE	1	
0051	CH00027	laminated capacitor	0.1uF/100V X7R PH5mm	4	
0052	ME00016	color nut	4m/m	1	pillar
0053	MF00038	washer-RS	4* 7*1t	1	pillar
0054	MJ00344	solder plate	AMP	1	pillar
0055	CB00322	electrolytic capacitor-RS	820uF/35V 105 WL 10*30mm(JAMICON)	3	
0056	CB00381	electrolytic capacitor-RS	330uF/200V 105°C 18*30mm (SAMXON)	6	

Rank	Part No.	Description	Specification	QTY	Remark
0057	CF00128	metal-film capacitor MSC	0.022uF/250V 5% CASE01	4	
0058	CG00094	X2 capacitor-RS	1.0uF/275V PX105K31F0H150D	1	
0059	CG00052	X1/Y2 capacitor AY2	4700PF VDE/UL ±20% X1:400V~ Y2:250V~	4	
0060	CG00095	X2 capacitor-RS	0.1uF/275V PX104K31D2H120D	1	
0061	CF00264	metal-film capacitor-RS	1.0uF/250V ± 5%(AC105J2ED4H150D)	2	
0062	CF00226	metal-film capacitor-RS MKP	0.33uF/160V 5%(BFC237934334)	4	
0063	CB00385	electrolytic capacitor-RS	330uF/200V 105 16*35mm(TBOR)	4	
0064	CF00224	metal-film capacitor-RS MKP	0.1uF/630V 5%(BFC238320104)	2	
0065	MB06186	chassis-RS	DIGMOD V1.0	1	
0001	ME00221	iron pillar	M3*4*0.8PH V1.0	8	
0002	ME00220	iron pillar	M4*8*0.7PH V1.0	1	
0003	MB06185	chassis-RS	DIGMOD V1.0	1	
0066	NE18923	label-RS	DPSAMP1500 V1.0	1	
0001	NI00018	membrane	0.06*1M	1	
0002	NI00039	adhesive label	0.06*1M	1	
0098	HK07847	PC board	P-DPSAMP1000(APM120)- DIP	1	
0001	SD00066	integrated circuit	L7812CV(TO220)/(ST)	1	
0002	NI00280	sleeve	15*25mm	1	RV1
0001	NI00278	sleeve	15*1000mm	25	
0003	MG00161	screw	M3*6	2	
0004	HC00359	connector	2.54 180° 4P(gold-plated) 6/11.6mm	2	
0005	HC00389	connector(male)	16P 2.54mm180°	1	
0006	HC00082	connector(male)	8P 2.5mm 180°	1	
0007	HC00276	connector(male)	3P 2.54mm 180°	2	
0008	HC00034	short circuit connector	NO.2700 2.54mm/6mm OPEN	4	
0009	CF00153	metal-film capacitor MSC	0.022uF/100V 5% CASE01	4	
0010	CF00016	metal-film capacitor MSC	0.01uF/100V 5% CASE01	1	
0011	HA01919	jump	5mm	1	
0001	HA02249	wire	0.6	0.015	
0012	CB00038	electrolytic capacitor	47uF/16V 5*7mm	2	
0013	CH00027	laminated capacitor	0.1uF/100V X7R PH5mm	4	
0014	MK00115	spring-RS	1.0T*7.6*13*34.2(ML00004) V 1.3	8	
0015	MC00801	top cover-RS-ACT	DigiMod 1.0t*48*116*136.8(ME00015 6) V1.4	1	
0001	MJ01449	hot gradual zinc-RS- CT	1.0t*2135*1220 20.45kg V1.0	1	
0002	ME00222	iron pillar	M3*4*0.5PH	2	
0016	HC00859	terminal block-RS	2P 7EHDV-02P male	2	
0017	HC00858	terminal block-RS	2P 2EHDV-02P male	2	
0018	HC00857	terminal block-RS	4P 2EHDV-04P male	1	
0019	HC00856	terminal block-RS	5P 2EHDV-05P male	2	
0020	CB00322	electrolytic capacitor-RS	820uF/35V 105 WL 10*30mm(JAMICON)	3	
0021	HC00866	row-wire header- RS-ACT	72P 1.27mm 180° (AMP:5822021-4)	1	

Rank	Part No.	Description	Specification	QTY	Remark
0022	NC00980	Silicone insulator-RS	1.0t*25mm*30mm	1	
0023	CN00180	common inductance-RS	1.90uH~2.30uH/T50-2(TO000061)	2	
0024	RA01614	chassis bracket 5W	4.7 ±5% SQM type	2	
0025	HC00879	connector(male)-RS	2*5P 3.0mm 180°(C3030WV-F-2*5P)	1	
0026	SD00318	integrated circuit-RS-C	TC4423EPA(PDIP8)/(MICRO CHIP)	5	
0027	SD00317	integrated circuit	NJM7912FA(TO220F)/(JRC)	1	
0028	SA00309	high speed diode-RS	BYW51FP-200(TO220AB)/(ST)	3	
0029	AC00179	tin without lead-RS	M705E Sn 3Ag-0.5Cu	23.94	
0030	MG00692	screw-RS	M3*12*0.5PH	11	
0031	ME00226	screw-RS	M3*0.5PH	11	
0032	MG00694	screw-RS	M2.9*9.5	6	
0033	MG00693	screw-RS	M3*6*0.5PH	8	
0034	SA00316	bridge rectifier-RS	8A GBU-8K(PANJIT)	1	
0035	NE16112	lable	K-SERIES V1.0	1	
0001	NI00020	membrane	0.07*1M	1	
0002	NH00016	bond paper	0.08*1M	1	
0036	NC01179	insulator spacer-RS	0.13t*40mm*55mm(HI-FLOW-625)	3	
0037	NI04389	plastic washer-RS	TW-20N	2	
0038	SB00226	transistor-RS-CT	IRFP260NPBF(TO247)/(IR)	4	
0039	SB00221	transistor-RS-CT	BD237(SOT32)/(ST)	1	
0040	SB00222	transistor-RS-CT	HGTG12N60A4D(TO247)/(FAIRCHILD)	2	
0041	RA01654	wirewound resistor 5W	0.1 ±5%/(AC05000001007JAC00)	4	
0042	RH00032	thermistor-RS-NTC	10K±5%/(NTCLE100E3103JB0)	2	
0043	SB00227	Pohtotriode-RS	CNY17F2M(DIP6)/(FAIRCHILD)	1	
0044	CN00200	common inductance-RS-CT	2.3mH/4A EV28-4.0-02-2M3/(SCHAFFNER)	2	
0045	RA01659	metal-oxide-film resistor-RS 1/2W	240K ±5% VR37(VR37000002403JA100)	1	
0046	CG00081	Y-type capacitor-RS-ACT	S20-K300(B72220301K101)/(EPCOS)	1	
0047	HC00941	fuse drawer-RS-ACT	520101(5.2mm) PCB式 LITTLEFUSE	1	
0048	RH00034	thermistor-RS-CT	2.5 B57237S259M/(EPCOS)	1	
0049	HK07157	PC board	P-DGM1000(PowerSoft)-	1	
0001	SE00025	SMD diode-RS	0.45A/85V BAV99	5	
0002	RD00255	SMD precise resistor 1/4W	100K ±1% 1206	14	
0003	RD00245	SMD precise resistor 1/4W	1.00K ±1% 1206	7	
0004	RD00399	SMD precise resistor 1/4W	10.0K ±1% 1206	4	
0005	RD00140	SMD fixed resistor 1/4W	4.7K ±5% 1206	1	
0006	CI00095	SMD ceramic capacitor 1206	0.1uF/50V X7R	4	
0007	CI00103	SMD ceramic capacitor 1206	100PF/50V NPO ±5%	1	

Rank	Part No.	Description	Specification	QTY	Remark
0008	CI00042	SMD ceramic capacitor 1206	0.001uF/50V NPO	12	
0009	CI00135	SMD ceramic capacitor 1206	33PF/50V NPO ±5%	1	
0010	CI00046	SMD ceramic capacitor 1206	1uF/16V Y5V-1206(3216)	23	
0011	CI00041	SMD ceramic capacitor 1206	470PF/50V NPO	1	
0012	CI00263	SMD ceramic capacitor-RS 1206	0.0047uF/200V X7R ±10%	6	
0013	RD00615	SMD precise resistor-RS 1/8W	1.50 ±5% 0805	3	
0014	RD00607	SMD precise resistor-RS 1/4W	330 ± 1% 1206	12	
0015	RD00605	SMD precise resistor-RS 1/4W	4.70 ± 1% 1206	4	
0016	RD00606	SMD precise resistor-RS 1/4W	15.0 ± 1% 1206	2	
0017	RD00604	SMD precise resistor-RS 1/4W	47.0 ± 1% 1206	1	
0018	SG00465	SMD integrated circuit-RS	M24C16WMN6TP(SO8)/(ST)	1	
0019	AE00449	solder material without lead	9308/Sn Ag Cu	0.456	
0020	SG00466	SMD integrated circuit-RS-ACT	HCPL-0611#060(SO8)/(AGILENT)	4	
0021	SE00089	SMD zener diode-RS	1/2W 5.1V(MMSZ5231B)(SOD-123)/(PANJIT)	4	
0022	SF00101	voltage stabilized transistor-RS	L4941BDT-TR-PB FREE(DPAK)/(ST)	1	
0023	SG00495	SMD integrated circuit-RS	IR2156SPBF(SO14)/(IR)	1	
0024	SE00095	SMD diode-RS-CT	ES3D(DO214AB)/(VISHAY)	3	
0025	SE00097	SMD diode-RS-CT	1A/400V US1G(DO214AC)/(VISHAY)	7	
0026	CI00279	SMD ceramic capacitor-RS 1206	0.0022uF/200Vx7R±10%	1	
0027	SE00098	SMD zener diode-RS-C	1W 15V DL4744A MELF/(SJ)	2	
0028	CO00138	SMD fixed inductance-RS-CT	4*0.47mH(B82792-C2474-N315/(EPCOS)	1	
0029	HB02847	PCB-RS	DPSAMP1000 VER080319	1	
0030	RD00635	SMD precise resistor-RS 1/4W	33.0K ±1% 1206	1	
0050	TC00330	transformer-RS	EE42/20(TO000068)	1	
0001	NI04468	creel stand-RS-ACT	FE0252(MILES PLATTS)	1	
0002	TC00386	transformer-RS	EE42/20(TO000068)	1	
0051	HK07198	PC board-RS	P-DGMFILT14(TO000062)	2	
0001	HC00855	connector-RS	2.54 90° 2*2P (gold-plated) 6/14.4/19.5	2	
0002	AC00179	tin without lead-RS	M705E Sn 3Ag-0.5Cu	0.252	
0003	NI00218	cable tie	ALT-102SB	1	
0004	CN00179	common inductance-RS	25.344uH±10%/T130-2(TO000062)	1	
0005	HB02845	PCB-RS	DPSAMP1000FILT(2*3)_VE R080319	1	

Rank	Part No.	Description	Specification	QTY	Remark
0052	NE16887	lable-RS	POWERMOD_V1.0	1	stick behind X2 capacitor after download test
0001	NI00015	membrane	0.04*1M	1	
0002	NH00014	bond paper	0.05*1M white	1	
0053	HK07158	PC board	P-DGM500-1000/CNTRL17-DIP	1	
0001	SC00319	crystal oscillator	12.288MHZ	1	
0002	HK07274	Photodiode	P-photosensitive resistance+ 3Iled	2	
0001	RH00020	photosensitive resistance	VT90N1	1	
0002	SA00305	L.E.D-RS	3 circle red high intensity	1	
0003	NI02405	sleeve	5*15mm	1	
0003	AC00179	tin without lead-RS	M705E Sn 3Ag-0.5Cu	1.3596	
0004	HK07159	PC board	P-DGM500-1000/CNTRL17-SMD	1	
0001	SG00045	SMD integrated circuit	BU4081BF(SOT73)/(PHI)	1	
0002	SF00030	SMD transistor-RS-ACT	BC817(SOT23)/(PHI)	2	
0003	RD00298	SMD precise resistor 1/10W	47.0 ±1% 0603	11	
0004	RD00201	SMD precise resistor 1/10W	1.50K ±1% 0603	5	
0005	RD00292	SMD precise resistor 1/10W	1.00M ±1% 0603	9	
0006	SG00001	SMD integrated circuit	TL074CDT(SO14)/(ST)	2	
0007	SE00025	SMD diode-RS	0.45A/85V BAV99	4	
0008	SE00027	SMD diode-RS	0.45A/85V BAW56	5	
0009	SE00026	SMD diode-RS	0.45A/85V BAV70	7	
0010	RD00320	SMD precise resistor 1/4W	12.0K ±1% 1206	4	
0011	RD00322	SMD precise resistor 1/10W	2.70K ±1% 0603	14	
0012	RD00339	SMD precise resistor 1/10W	47.0K ±1% 0603	8	
0013	RD00342	SMD precise resistor 1/10W	1.50M ±1% 0603	2	
0014	RD00332	SMD precise resistor 1/10W	680 ±1% 0603	2	
0015	RD00214	SMD precise resistor 1/10W	10.0K ±1% 0603	45	
0016	RD00218	SMD precise resistor 1/10W	15.0K ±1% 0603	6	
0017	RD00224	SMD precise resistor 1/10W	100K ±1% 0603	8	
0018	RD00506	SMD precise resistor 1/10W	3.30K ±1% 0603	8	
0019	RD00509	SMD fixed resistor 1/10W	24K ±5% 0603	1	
0020	RD00399	SMD precise resistor 1/4W	10.0K ±1% 1206	4	
0021	RD00282	SMD precise resistor 1/10W	1.00K ±1% 0603	20	
0022	RD00390	SMD precise resistor 1/10W	10.0M ±1% 0603	2	

Rank	Part No.	Description	Specification	QTY	Remark
0023	RD00392	SMD precise resistor 1/10W	2.20K ±1% 0603	7	
0024	RD00105	SMD fixed resistor 1/10W	22K ±5% 0603	1	
0025	RD00129	SMD fixed resistor 1/4W	0.0 ±5% 1206	2	
0026	RD00525	SMD precise resistor 1/10W	33.0K ±1% 0603	2	
0027	RD00301	SMD precise resistor 1/10W	12.1K ±1% 0603	2	
0028	CI00125	SMD ceramic capacitor 1210	10uF/16V Y5V-1210(3225)	5	
0029	CI00105	SMD ceramic capacitor 1206	0.0022uF/50V NPO ±5%	2	
0030	CI00185	SMD ceramic capacitor 0603	0.1uF/50V X7R±10%(C1608X7R1H104KT)/TDK	25	
0031	CI00053	SMD ceramic capacitor 0603	33PF/50V C0G±5%(C1608C0G1H330JT)/TDK	2	
0032	CI00083	SMD ceramic capacitor 0603	3.9PF/50VC0G±0.25PF(C1608C0G1H3R9CT)TDK	2	
0033	CI00084	SMD ceramic capacitor 0603	4.7PF/50VC0G±0.25PF(C1608C0G1H4R7CT)TDK	1	
0034	CI00201	SMD ceramic capacitor 0603	0.01uF/50V ±10%(C1608X7R1H103KT)/TDK	4	
0035	CI00224	SMD ceramic capacitor 0603	470PF/50V C0G ±5%(C1608C0G1H471JT)/TDK	8	
0036	CI00234	SMD ceramic capacitor 0603	0.0033uF/50VC0G±5%(C1608C0G1H332JT)/TDK	1	
0037	CI00220	SMD ceramic capacitor 0603	220PF/50V C0G ±5%(C1608C0G1H221JT)/TDK	3	
0038	CI00216	SMD ceramic capacitor 0603	82PF/50V C0G ±5%(C1608C0G1H820JT)/TDK	4	
0039	CI00228	SMD ceramic capacitor 0603	0.001uF/50V C0G±5%(C1608C0G1H102JT)/TDK	4	
0040	CI00222	SMD ceramic capacitor 0603	330PF/50V C0G ±5%(C1608C0G1H331JT)/TDK	4	
0041	SE00077	SMD L.E.D-RS	red KPTC-2012EC	2	
0042	SE00078	SMD L.E.D-RS	green KPTC-2012SGC	3	
0043	RD00592	SMD precise resistor-RS 1/10W	10.0K ±0.1% 0603	8	
0044	RD00590	SMD precise resistor-RS 1/10W	1.50K ±0.1% 0603	4	
0045	RD00591	SMD precise resistor-RS 1/10W	82.0K ±0.1% 0603	4	
0046	AE00449	solder material without lead	9308/Sn Ag Cu	1.5924	
0047	SE00090	SMD zener diode-RS	1/2W 6.8V(MMSZ5235B)(SOD-123)/(PANJIT)	4	
0048	SG00496	SMD integrated circuit-RS	LF412CDR(SO8)/(TI)	2	
0049	CO00137	SMD inductance-RS	1.0mH ±5%(NL453232T-102J)/(TDK)	2	
0050	SG00502	SMD integrated circuit-RS	NE5532DR(SO8)/(TI)	4	

Rank	Part No.	Description	Specification	QTY	Remark
0051	SG00509	SMD integrated circuit-RS	HEF4069UBT(SO14)/(PHI)	2	
0052	CI00278	SMD ceramic capacitor-RS 1206	0.0018uF/50V NPO ±5%	2	
0053	RD00415	SMD precise resistor 1/10W	4.70K ±1% 0603	6	
0054	HB02848	PCB-RS	DPSAMP1000CTRL(1*5)_V ER080319	1	
0055	SG00661	SMD integrated circuit-RS	ATmega8- 16AU(TQFP32)/(ATMEL) CS:001F9B76	1	
0005	NE16833	lable-RS	DIGIMOD1000 V1.0	1	
0001	NI00018	membrane	0.06*1M	1	
0002	NH00035	bond paper	0.06*1M	1	
0006	NE16889	lable-RS	DIGIMOD1000 V1.0	1	
0001	NI00018	membrane	0.06*1M	1	
0002	NH00035	bond paper	0.06*1M	1	
0007	NE16886	lable-RS	DIGIMOD1000 V1.0	1	
0001	NI00016	membrane	0.05*1M	1	
0002	NH00014	bond paper	0.05*1M white	1	
0054	ME00016	color nut	4m/m	1	pillar
0055	MF00038	washer-RS	4* 7*1t	1	pillar
0056	MJ00344	solder plate	AMP	1	pillar
0057	CB00378	electrolytic capacitor-RS	220uF/200V 105°C 18*30mm (SAMXON)	6	
0058	CB00379	electrolytic capacitor-RS	390uF/100V 105°C 16*30mm (SAMXON)	4	
0059	CG00094	X2 capacitor-RS	1.0uF/275V PX105K31F0H150D	1	
0060	CG00052	X1/Y2 capacitor AY2	4700PF VDE/UL ±20% X1:400V~ Y2:250V~	4	
0061	CG00095	X2 capacitor-RS	0.1uF/275V PX104K31D2H120D	1	
0062	CF00264	metal-film capacitor-RS	1.0uF/250V ± 5%(AC105J2ED4H150D)	2	
0063	CF00226	metal-film capacitor-RS MKP	0.33uF/160V 5%(BFC237934334)	4	
0064	CF00224	metal-film capacitor-RS MKP	0.1uF/630V 5%(BFC238320104)	2	
0065	MB06186	chassis-RS	DIGMOD V1.0	1	
0001	ME00221	iron pillar	M3*4*0.8PH V1.0	8	
0002	ME00220	iron pillar	M4*8*0.7PH V1.0	1	
0003	MB06185	chassis-RS	DIGMOD V1.0	1	
0066	NE18921	label-RS	DPSAMP1000 V1.0	1	
0001	NI00018	membrane	0.06*1M	1	
0002	NI00039	adhesive label	0.06*1M	1	
0099	HK07395	PC board	P-PSM-50Wd-DIP	1	
0001	SD00074	integrated circuit	L7805CV(TO220)/(ST)	1	
0002	SD00079	integrated circuit	L7915CV(TO220)/(ST)	1	
0003	SD00077	integrated circuit-RS	L7815CV(TO220)/(ST/MOR OCCO)	1	
0004	SD00066	integrated circuit	L7812CV(TO220)/(ST)	1	
0005	SA00223	zener diode-RS-ACT	3.6W 36V KA431AZ(TO-92)	1	
0006	SA00221	bridge rectifier	2A/600V KBP206	1	

Rank	Part No.	Description	Specification	QTY	Remark
0007	SA00222	diode-RS-ACT	2.2A/274V P6KE200A	1	
0008	SB00073	transistor-RS-ACT	2N5550/2N5551(TO92)/(HS MC)	1	
0009	SB00064	transistor-RS-ACT	TIP41C(TO220)/(ST)	1	
0010	SA00130	diode-RS-ACT	1A/600V/35ns BYV26C	3	
0011	SA00144	diode-RS	BYV28-200-TAP(SOD64)/(VISHAY)	2	
0012	SA00127	zener diode	1/2W 47V 1N5261	1	
0013	SA00004	high speed diode-RS	2A/100V BYV27-200,113	2	
0014	NI02249	plastic washer	TW-1(TO-220)	2	Q2,U3
0015	NC00167	mica-RS	13*18(3.6)TO-220	2	Q2,U3
0016	MI00257	heat-sink	25*34.6*12*1.5 DX26	4	
0017	MI00256	heat-sink	25*15*10.6-1PIN SCL-2020	1	
0018	MG00161	screw	M3*6	2	heat sink
0019	MG00163	screw	M3*8	6	
0020	MF00037	washer	3.2* 5.5*1t	5	U1,U2,U6,TR1,Q2
0021	ME00015	color nut	3m/m	4	
0022	MF00014	washer	3* 6.5*0.5t	2	heat sink
0023	HC00172	connector(male)	3P 3.96mm 180°	1	
0024	HC00076	connector(male)	2P 2.5mm 180°	2	
0025	HC00082	connector(male)	8P 2.5mm 180°	1	
0026	CB00132	electrolytic capacitor	330uF/25V 105 LZ 8*15mm	3	
0027	CB00189	electrolytic capacitor	1.0uF/50V 4*5mm	1	
0028	CB00195	electrolytic capacitor	100uF/16V 6*7mm	2	
0029	CB00034	electrolytic capacitor	33uF/16V 5*11mm	1	
0030	CF00113	metal-film capacitor MPX	0.047uF/275V ±10% CASEC2	2	
0031	CB00188	electrolytic capacitor	10uF/63V 5*11mm 2.5mm	2	
0032	CG00035	Y-type capacitor-RS	4.7nF/400V	2	
0033	CG00033	metal oxide varistors	B57237-S100-M	1	
0034	CB00254	electrolytic capacitor	47uF/100V 10*12mm 5mm	1	
0035	HA01925	jump	10mm	3	
0036	HA01930	jump	15mm	1	
0037	HA01921	jump	7mm	1	
0038	CB00201	electrolytic capacitor	47uF/25V 6*7mm	1	
0039	CB00256	electrolytic capacitor	1000uF/25V 10*20mm 5mm	2	
0040	CB00056	electrolytic capacitor	220uF/25V 8*11mm	1	
0041	CN00153	inductance-RS-ACT	3mH UT20-H125NP	1	
0042	TC00341	transformer-RS	ETD29 230V	1	
0043	AC00179	tin without lead-RS	M705E Sn 3Ag-0.5Cu	2.922	
0044	SD00319	integrated circuit-RS	TOP248YN(TO220)/(PI)	1	
0045	CB00337	electrolytic capacitor-RS	220uF/400V 30*31mm	1	
0046	HK07396	PC board	P-PSM-50Wd-SMD	1	
0001	RD00015	SMD fixed resistor 1/8W	560 ±5% 0805	1	
0002	RD00141	SMD fixed resistor 1/4W	6.8K ±5% 1206	1	

Rank	Part No.	Description	Specification	QTY	Remark
0003	RD00025	SMD fixed resistor 1/8W	3.3K ±5% 0805	1	
0004	RD00235	SMD precise resistor 1/8W	4.70K ±1% 0805	1	
0005	RD00515	SMD precise resistor 1/4W	4.7 ±1% 1206	1	
0006	RD00254	SMD precise resistor 1/4W	68.0K ±1% 1206	1	
0007	RD00149	SMD fixed resistor 1/4W	220K ±5% 1206	3	
0008	RD00142	SMD fixed resistor 1/4W	10K ±5% 1206	2	
0009	RD00146	SMD fixed resistor 1/4W	47K ±5% 1206	1	
0010	CI00100	SMD ceramic capacitor 0805	0.1uF/50V X7R ±10%	2	
0011	CI00028	SMD ceramic capacitor 0805	0.01uF/50V Y5V	1	
0012	CI00154	SMD ceramic capacitor 1206	0.1uF/100V X7R ±10%	7	
0013	RD00585	SMD precise resistor -RS	820.00 ±1% 0805	1	
0014	RD00617	SMD fixed resistor- RS 1/4W	2.0M ±5% 1206	1	
0015	HB02120	PCB-RS	PSM-50WD VER070323	1	
0016	RD00521	SMD fixed resistor 1/8W	750 ±5% 0805	1	
0047	MI03891	separating shade-RS	XM-24 0.33t*37.6*37.6*28.3 V1.1	1	
0048	MI03847	heat-sink-RS	2.9*77*30*15 V1.2	1	
0049	SB00227	Pohtotriode-RS	CNY17F2M(DIP6)/(FAIRCHI LD)	1	
0050	SA00175	Schottky barrier diode	1A/40V 1N5819	1	
0051	CG00023	X1/Y1 capacitor	0.0022uF/250VAC Y5U	2	
0100	HK07692	PC board	P-APM120 MONO-DIP	4	
0001	RC00671	potentiometer-RS	C500K XV012313YGPV30F- 15C500K C.C	4	
0002	RC00672	potentiometer-RS	B50K XV09213YNPV30F- 1B50K C.C	12	
0003	RC00700	potentiometer-RS	B5K XV09213YNPV30F- 1BP5K CC	4	
0004	SB00062	transistor-RS-ACT	BC337-25(TO92)/(PHI)	1	
0005	SA00071	L.E.D	3 green LVG2340/A	4	
0006	HC00125	MIC jack-RS	JY-6351G-02-250	8	
0007	RC00727	potentiometer-RS	Z10K XV09213YNPV30F914Z10K	4	
0008	HI00236	push-button switch- RS	2 6P KFC-D85-C(SELF- LOCK)	20	
0009	SA00053	L.E.D	3 round(red)long foot 26mm	5	
0010	HC00126	balance MIC jack- RS	JY-5042-030G female plug 180°	4	
0011	HI00380	slide switch-RS	2stage 3P 12mm SBA-12-12	1	
0012	RC00703	potentiometer-RS	W50K XV09213YNPV30F-4BP50K	16	
0013	SA00054	L.E.D	3m/m round(yellow)long foot 26	4	
0014	SA00073	L.E.D	3 yellow LVY2340/A	4	
0015	NI02384	LED spacer support	LEDS-4 4mm	8	

Rank	Part No.	Description	Specification	QTY	Remark
0016	NI01773	LED spacer support	LEDS-13	9	
0017	NI04453	LED spacer support-RS	LEDS-21 21mm	1	
0018	HC00982	connector-RS	2.0mm 180° 2*10P 4/9.4	1	back-solder
0019	HC00984	connector-RS	2.0mm 180° 2*2P 4/9.4	1	back-solder
0020	HC00983	connector-RS	2.0mm 180° 2*4P 4/9.4	1	back-solder
0021	AC00179	tin without lead-RS	M705E Sn 3Ag-0.5Cu	13.646	
0022	HK07693	PC board	P-APM120 MONO-SMD	1	
0001	CI00075	SMD ceramic capacitor 0603	0.1uF/50V Y5V +80,-20%	28	
0002	RD00214	SMD precise resistor 1/10W	10.0K ±1% 0603	13	
0003	RD00334	SMD precise resistor 1/10W	11.0K ±1% 0603	8	
0004	RD00102	SMD fixed resistor 1/10W	12K ±5% 0603	4	
0005	RD00218	SMD precise resistor 1/10W	15.0K ±1% 0603	4	
0006	RD00293	SMD precise resistor 1/10W	17.4K ±1% 0603	16	
0007	RD00351	SMD fixed resistor 1/10W	1.3K ±5% 0603	4	
0008	RD00201	SMD precise resistor 1/10W	1.50K ±1% 0603	8	
0009	RD00125	SMD fixed resistor 1/10W	1.0M ±5% 0603	4	
0010	RD00219	SMD precise resistor 1/10W	20.0K ±1% 0603	13	
0011	RD00105	SMD fixed resistor 1/10W	22K ±5% 0603	4	
0012	CI00266	SMD ceramic capacitor-RS 0603	22PF/50V NPO ±5 %	28	
0013	RD00106	SMD fixed resistor 1/10W	27K ±5% 0603	8	
0014	RD00265	SMD fixed resistor 1/10W	27 ±5% 0603	4	
0015	RD00089	SMD fixed resistor 1/10W	2.7K ±5% 0603	8	
0016	SF00056	transistor	MMBT3904(SOT23)/(PHI)	16	
0017	RD00406	SMD precise resistor 1/10W	3.60K ±1% 0603	8	
0018	RD00092	SMD fixed resistor 1/10W	3.9K ±5% 0603	4	
0019	SE00011	SMD rectifier diode	RLS4148 0.5A (LL-34)	18	
0020	CI00063	SMD ceramic capacitor 0603	470PF/50V NPO ±5 %	12	
0021	RD00339	SMD precise resistor 1/10W	47.0K ±1% 0603	4	
0022	CI00268	SMD ceramic capacitor-RS 0603	47PF/50V NPO ±5 %	4	
0023	RD00298	SMD precise resistor 1/10W	47.0 ±1% 0603	8	
0024	RD00371	SMD precise resistor 1/10W	51.1K ±1% 0603	8	
0025	RD00094	SMD fixed resistor 1/10W	5.1K ±5% 0603	16	
0026	RD00210	SMD precise resistor 1/10W	5.11K ±1% 0603	16	

Rank	Part No.	Description	Specification	QTY	Remark
0027	RD00095	SMD fixed resistor 1/10W	5.6K ±5% 0603	8	
0028	RD00113	SMD fixed resistor 1/10W	62K ±5% 0603	4	
0029	RD00539	SMD precise resistor 1/10W	68.0K ±1% 0603	4	
0030	RD00097	SMD fixed resistor 1/10W	6.8K ±5% 0603	28	
0031	AE00449	solder material without lead	9308/Sn Ag Cu	0.192	
0032	HK07694	PC board	P-APM120 MONO-AI	1	
0001	HB02185	PCB-RS	APM120 MONO_VER071029	1	
0002	CB00238	electrolytic capacitor	0.22uF/50V 5*11mm	12	
0003	CB00255	electrolytic capacitor	1000uF/10V 8*11mm 5mm	4	
0004	RA01112	fixed resistor 1/4W	100	1	
0005	CB00051	electrolytic capacitor	100uF/63V 10*12mm	1	
0006	RA01115	fixed resistor 1/4W	20K	1	
0007	CB00242	electrolytic capacitor	22uF/35V 5*11mm	8	
0008	CC00067	mylar capacitor	0.0027uF/100V 10%	4	
0009	CC00059	mylar capacitor	0.033uF/100V 3%	8	
0010	CB00194	electrolytic capacitor	47uF/25V 5*11mm	24	
0011	CB00334	electrolytic capacitor-RS	47uF/50V 6.3*11mm	8	
0012	CC00077	mylar capacitor	0.0047uF/100V 3%	4	
0013	RA01262	precise resistor 1/4W	6.81K ±1%	8	
0014	CC00079	mylar capacitor	0.0068uF/100V 3%	8	
0015	HA01919	jump	5mm	101	
0016	HA01930	jump	15mm	19	
0017	HA01935	jump	12.5mm	13	
0018	HA01925	jump	10mm	36	
0019	HA02441	jump	7.5mm	51	
0033	SG00122	SMD integrated circuit-RS-ACT	NJM4580M- TE3(SOP8)/(JRC)	14	
0023	RC00284	slide potentiometer	D10K RF6011YP600F- 10KD(SAS1)	4	
0101	HK07698	PC board	P-APM200 STEREO-DIP	1	
0001	SD00007	integrated circuit	BA15218N(M5218L代 用)(SIP8)/(ROHM)	2	
0002	SB00062	transistor-RS-ACT	BC337-25(TO92)/(PHI)	1	
0003	RC00625	slide potentiometer- RS	W100K RF30H12KD107- 100K(4B)*2(SAS)	18	
0004	RC00700	potentiometer-RS	B5K XV09213YNPV30F- 1BP5K CC	2	
0005	RC00703	potentiometer-RS	W50K XV09213YNPV30F-4BP50K	16	

Rank	Part No.	Description	Specification	QTY	Remark
0006	RC00757	potentiometer-RS	W50K RK09K1130265-50K4BT(SAS1)	4	
0007	RC00626	potentiometer-RS	B100K RD12L12C0217-100K3B*2(SAS);15F	1	
0008	RC00670	potentiometer-RS	W50K XV012313YGPV30F-4B50K C.C	6	
0009	RC00669	potentiometer-RS	B50K XV012313YGPV30F-3B50K	8	
0010	SA00052	L.E.D	3 round(green)long foot 26	25	
0011	SA00054	L.E.D	3m/m round(yellow)long foot 26	6	
0012	SA00053	L.E.D	3 round(red)long foot 26mm	14	
0013	NI01773	LED spacer support	LEDS-13	45	
0014	SA00071	L.E.D	3 green LVG2340/A	13	
0015	SA00073	L.E.D	3 yellow LVY2340/A	2	
0016	NI02384	LED spacer support	LEDS-4 4mm	15	
0017	HI00236	push-button switch-RS	2 6P KFC-D85-C(SELF-LOCK)	7	
0018	HI00238	push-button switch-RS	2 6P KFC-D85-D(NON-LOCK)	2	
0019	HI00237	push-button switch-RS	2 12P KFC-D130-B(SELF-LOCK)	14	
0020	HI00161	relay	RY-5W-K,5V	2	
0021	HI00195	rotary switch-RS-ACT	SDB161PVB15.5F-1-4-16-16PC	4	
0022	HI00400	slide switch-RS	2stage 6P 15mm SKA-22 15L	2	
0023	HI00360	slide switch-RS	SKA-43-14.5	2	
0024	HI00384	slide switch-RS	2stage 3P 4mm SBA-12CN-04RB	1	
0025	HC00125	MIC jack-RS	JY-6351G-02-250	24	
0026	HC00403	RCA jack	SCP6873NS3232T2 4P	1	
0027	HC00887	connector(male)-RS	2*10P 2.0mm 180° (A2004WV-2*10P)	1	
0028	HC00932	connector(male)-RS	2*4P 2.0mm 180°(A2004WV-2*4P)	2	
0029	HC00086	connector(male)	12P 2.5mm 180°	1	
0030	HC00080	connector(male)	6P 2.5mm 180°	2	
0031	HC00473	connector-RS	2.45mm 180° 2*8P B25-2*8BG1(B)H=5mm	2	
0032	HK07637	PC board	P-DSP-PRE-DIP(APM120)	2	
0001	HC00697	connector	2.0 90° 16P(gold-pated)2.5/9.5mm 2mm	1	
0002	AC00179	tin without lead-RS	M705E Sn 3Ag-0.5Cu	0.3996	
0003	HK07638	PC board	P-DSP-PRE-SMD(APM120)	1	
0001	HB01916	PCB-RS	DSP-PRE(1*10)_VER070316	1	
0002	SG00306	SMD integrated circuit	LM393DR(TI)/(MEXICO)	1	
0003	SG00469	SMD integrated circuit-RS	SN74HC109DR(SO16)/(TI)	1	
0004	SG00068	SMD integrated circuit	74HC14DT(SO14)/(PHI)	1	
0005	SF00056	transistor	MMBT3904(SOT23)/(PHI)	1	
0006	RD00068	SMD fixed resistor 1/10W	100 ±5% 0603	2	
0007	SE00007	SMD rectifier diode	RB400D(D3A)	1	

Rank	Part No.	Description	Specification	QTY	Remark
0008	SE00009	SMD rectifier diode-RS	DAN202K/T-146	1	
0009	SE00028	SMD rectifier diode-RS-ACT	BAS316,115	2	
0010	RD00059	SMD fixed resistor 1/10W	0.0 ±5% 0603	1	
0011	RD00083	SMD fixed resistor 1/10W	1.0K ±5% 0603	1	
0012	RD00099	SMD fixed resistor 1/10W	8.2K ±5% 0603	2	
0013	RD00101	SMD fixed resistor 1/10W	10K ±5% 0603	14	
0014	RD00093	SMD fixed resistor 1/10W	4.7K ±5% 0603	1	
0015	RD00098	SMD fixed resistor 1/10W	7.5K ±5% 0603	1	
0016	RD00111	SMD fixed resistor 1/10W	47K ±5% 0603	1	
0017	RD00125	SMD fixed resistor 1/10W	1.0M ±5% 0603	1	
0018	RD00124	SMD fixed resistor 1/10W	820K ±5% 0603	1	
0019	RD00126	SMD fixed resistor 1/10W	2.2M ±5% 0603	1	
0020	CI00129	SMD ceramic capacitor 0603	0.0015uF/50V X7R ±10%	2	
0021	CL00002	SMD tantalum capacitor-RS-ACT	1.0uF/16V case A	2	
0022	CI00053	SMD ceramic capacitor 0603	33PF/50V C0G±5%(C1608C0G1H330JT)/TD	2	
0023	CL00006	SMD tantalum capacitor-RS-ACT	10uF/16V case B2	2	
0024	CI00051	SMD ceramic capacitor 0603	22PF/50V C0G±5%(C1608C0G1H220JT)/TD	4	
0025	CI00075	SMD ceramic capacitor 0603	0.1uF/50V Y5V +80,-20%	8	
0026	SE00085	SMD zener diode-RS	1/2W 2.4V ZMM55-C2V4	2	
0027	AE00449	solder material without lead	9308/Sn Ag Cu	0.1236	
0028	SG00243	SMD integrated circuit	NE555DR(SO8)/(TI)	1	
0029	SG00122	SMD integrated circuit-RS-ACT	NJM4580M-TE3(SOP8)/(JRC)	3	
0030	RD00306	SMD fixed resistor 1/10W	20K ±5% 0603	2	
0031	RD00349	SMD fixed resistor 1/10W	910 ±5% 0603	1	
0032	RD00092	SMD fixed resistor 1/10W	3.9K ±5% 0603	1	
0033	HK04376	PC board	P-12VMETER-DIP(AMX-2.0 90° 17P(gold-pated)2.5/9.5mm 2mm	2	
0001	HC00698	connector	P-12VMETER-SMD(AMX-220)	1	
0002	HK04377	PC board	12VMETER(2*5)_VER04061	1	
0001	HB01285	PCB	1	1	
0002	RD00069	SMD fixed resistor 1/10W	120 ±5% 0603	1	
0003	RD00076	SMD fixed resistor 1/10W	330 ±5% 0603	2	

Rank	Part No.	Description	Specification	QTY	Remark
0004	RD00078	SMD fixed resistor 1/10W	470 ±5% 0603	3	
0005	RD00347	SMD fixed resistor 1/10W	510 ±5% 0603	1	
0006	RD00348	SMD fixed resistor 1/10W	620 ±5% 0603	1	
0007	RD00351	SMD fixed resistor 1/10W	1.3K ±5% 0603	1	
0008	RD00087	SMD fixed resistor 1/10W	2.0K ±5% 0603	1	
0009	RD00101	SMD fixed resistor 1/10W	10K ±5% 0603	1	
0010	RD00115	SMD fixed resistor 1/10W	82K ±5% 0603	1	
0011	CI00075	SMD ceramic capacitor 0603	0.1uF/50V Y5V +80,-20%	2	
0012	SG00210	SMD integrated circuit	LM339DT/(ST)	3	
0013	AE00449	solder material without lead	9308/Sn Ag Cu	0.0876	
0014	RD00346	SMD fixed resistor 1/10W	56 ±5% 0603	1	
0003	AC00179	tin without lead-RS	M705E Sn 3Ag-0.5Cu	3.078	
0034	AC00179	tin without lead-RS	M705E Sn 3Ag-0.5Cu	30.544	
0035	HK07699	PC board	P-APM200 STEREO-SMD	1	
0001	RD00059	SMD fixed resistor 1/10W	0.0 ±5% 0603	2	
0002	RD00062	SMD fixed resistor 1/10W	18 ±5% 0603	12	
0003	RD00304	SMD fixed resistor 1/10W	33 ±5% 0603	4	
0004	RD00069	SMD fixed resistor 1/10W	120 ±5% 0603	18	
0005	RD00074	SMD fixed resistor 1/10W	270 ±5% 0603	4	
0006	RD00347	SMD fixed resistor 1/10W	510 ±5% 0603	2	
0007	RD00083	SMD fixed resistor 1/10W	1.0K ±5% 0603	6	
0008	RD00085	SMD fixed resistor 1/10W	1.5K ±5% 0603	4	
0009	RD00086	SMD fixed resistor 1/10W	1.8K ±5% 0603	16	
0010	RD00087	SMD fixed resistor 1/10W	2.0K ±5% 0603	5	
0011	RD00088	SMD fixed resistor 1/10W	2.2K ±5% 0603	12	
0012	RD00089	SMD fixed resistor 1/10W	2.7K ±5% 0603	8	
0013	RD00093	SMD fixed resistor 1/10W	4.7K ±5% 0603	8	
0014	RD00094	SMD fixed resistor 1/10W	5.1K ±5% 0603	43	
0015	RD00096	SMD fixed resistor 1/10W	6.2K ±5% 0603	36	
0016	RD00097	SMD fixed resistor 1/10W	6.8K ±5% 0603	12	
0017	RD00101	SMD fixed resistor 1/10W	10K ±5% 0603	105	
0018	RD00102	SMD fixed resistor 1/10W	12K ±5% 0603	8	

Rank	Part No.	Description	Specification	QTY	Remark
0019	RD00306	SMD fixed resistor 1/10W	20K ±5% 0603	59	
0020	RD00105	SMD fixed resistor 1/10W	22K ±5% 0603	6	
0021	RD00106	SMD fixed resistor 1/10W	27K ±5% 0603	12	
0022	RD00353	SMD fixed resistor 1/10W	36K ±5% 0603	14	
0023	RD00111	SMD fixed resistor 1/10W	47K ±5% 0603	8	
0024	RD00114	SMD fixed resistor 1/10W	68K ±5% 0603	38	
0025	RD00116	SMD fixed resistor 1/10W	100K ±5% 0603	6	
0026	RD00118	SMD fixed resistor 1/10W	150K ±5% 0603	4	
0027	RD00263	SMD fixed resistor 1/10W	200K ±5% 0603	4	
0028	RD00119	SMD fixed resistor 1/10W	220K ±5% 0603	4	
0029	RD00268	SMD fixed resistor 1/10W	300K ±5% 0603	2	
0030	RD00124	SMD fixed resistor 1/10W	820K ±5% 0603	4	
0031	RD00125	SMD fixed resistor 1/10W	1.0M ±5% 0603	8	
0032	RD00544	SMD precise resistance 1/10W	22 ±1% 0603	4	
0033	RD00298	SMD precise resistor 1/10W	47.0 ±1% 0603	6	
0034	RD00297	SMD precise resistor 1/10W	60.4 ±1% 0603	8	
0035	RD00394	SMD precise resistor 1/10W	68.0 ±1% 0603	8	
0036	RD00275	SMD precise resistor 1/10W	110 ±1% 0603	4	
0037	RD00276	SMD precise resistor 1/10W	169 ±1% 0603	4	
0038	RD00277	SMD precise resistor 1/10W	200 ±1% 0603	12	
0039	RD00542	SMD precise resistance 1/10W	220 ±1% 0603	8	
0040	RD00543	SMD precise resistance 1/10W	470 ±1% 0603	2	
0041	RD00209	SMD precise resistor 1/10W	4.99K ±1% 0603	1	
0042	RD00328	SMD precise resistor 1/10W	8.66K ±1% 0603	4	
0043	RD00214	SMD precise resistor 1/10W	10.0K ±1% 0603	48	
0044	RD00334	SMD precise resistor 1/10W	11.0K ±1% 0603	4	
0045	RD00218	SMD precise resistor 1/10W	15.0K ±1% 0603	12	
0046	RD00368	SMD precise resistor 1/10W	16.5K ±1% 0603	4	
0047	RD00293	SMD precise resistor 1/10W	17.4K ±1% 0603	39	
0048	RD00473	SMD precise resistor 1/10W	18.0K ±1% 0603	8	
0049	RD00420	SMD precise resistor 1/10W	19.1K ±1% 0602	3	
0050	RD00223	SMD precise resistor 1/10W	49.9K ±1% 0603	1	

Rank	Part No.	Description	Specification	QTY	Remark
0051	RD00471	SMD precise resistor 1/10W	56.2K ±1% 0603	10	
0052	RE00011	SMD resistor networks 1/16W	680 *4 ±5% 8P 1206(0603x4)	4	
0053	RD00002	SMD fixed resistor 1/8W	0.0 ±5% 0805	1	
0054	RD00007	SMD fixed resistor 1/8W	120 ±5% 0805	4	
0055	CI00266	SMD ceramic capacitor-RS 0603	22PF/50V NPO ±5 %	61	
0056	CI00267	SMD ceramic capacitor-RS 0603	33PF/50V NPO ±5 %	16	
0057	CI00059	SMD ceramic capacitor 0603	100PF/50V NPO ±5%	2	
0058	CI00062	SMD ceramic capacitor 0603	330PF/50V NPO ±5 %	4	
0059	CI00064	SMD ceramic capacitor 0603	680PF/50V NPO ±5 %	4	
0060	CI00075	SMD ceramic capacitor 0603	0.1uF/50V Y5V +80,-20%	78	
0061	CI00022	SMD ceramic capacitor 0805	0.001uF/50V X7R	4	
0062	CI00026	SMD ceramic capacitor 0805	0.0033uF/50V X7R ±10%	12	
0063	CI00116	SMD ceramic capacitor 0805	0.0039uF/50V X7R ±10%	4	
0064	CI00147	SMD ceramic capacitor 0805	0.0082uF/50V X7R ±10%	4	
0065	CI00289	SMD ceramic capacitor-RS	0.012uF/50V X7R ±10%	16	
0066	CI00151	SMD ceramic capacitor 0805	0.015uF/50V X7R ±10%	12	
0067	CI00097	SMD ceramic capacitor 0805	0.027uF/50V X7R ±10%	4	
0068	CI00133	SMD ceramic capacitor 0805	0.047uF/-50V X7R ±10 %	8	
0069	CI00099	SMD ceramic capacitor 0805	0.068uF/50V X7R ±10%	4	
0070	CI00100	SMD ceramic capacitor 0805	0.1uF/50V X7R ±10%	8	
0071	CI00305	SMD ceramic capacitor-RS	0.12UF/50V X7R ±10%	4	
0072	CI00146	SMD ceramic capacitor 0805	0.22uF/50V X7R ±10%	8	
0073	CI00276	SMD ceramic capacitor-RS	0.47uF/50V X7R ±10%	4	
0074	CI00306	SMD ceramic capacitor-RS	1.0uF/50V X7R ±10%	4	
0075	SF00056	transistor	MMBT3904(SOT23)/(PHI)	24	
0076	SF00053	transistor	MMBT3906(SOT23)/(PHI)	4	
0077	SE00011	SMD rectifier diode	RLS4148 0.5A (LL-34)	12	
0078	SE00016	SMD zener diode-RS-ACT	1/2W 5.1V(RLZ5.1B) LL-34	8	
0079	SE00008	SMD rectifier diode	DA204K/T-146	1	
0080	SF00031	SMD transistor-RS-ACT	BC847B(SOT23)/(PHI)	36	
0081	HK07700	PC board	P-APM200 STEREO-AI	1	
0001	CB00190	electrolytic capacitor	4.7uF/25V 4*7mm	6	

Rank	Part No.	Description	Specification	QTY	Remark
	0002	CB00192	electrolytic capacitor 10uF/16V 4*7mm	8	
	0003	CB00194	electrolytic capacitor 47uF/25V 5*11mm	101	
	0004	CB00195	electrolytic capacitor 100uF/16V 6*7mm	4	
	0005	CB00268	electrolytic capacitor 330uF/16V 8*11mm 5mm	2	
	0006	CB00255	electrolytic capacitor 1000uF/10V 8*11mm 5mm	1	
	0007	RA01112	fixed resistor 1/4W 100	1	
	0008	RA01260	fixed resistor 1/4W 120	2	
	0009	HB02276	PCB-RS APM200 STEREO VER071208	1	
	0082	SG00122	SMD integrated circuit-RS-ACT NJM4580M-TE3(SOP8)/(JRC)	38	
	0083	CI00307	SMD ceramic capacitor-RS 0.18uF/50V X7R ±10%	4	
	0036	RC00284	slide potentiometer D10K RF6011YP600F-10KD(SAS1)	3	
	0037	RC00285	slide potentiometer-dual unit D10K RF60112P600G-10KD*2(SAS1)	6	
0102		HK07709	PC board P-APM120SPEAK	1	
	0001	HB02230	PCB-RS APM120SPEAK VER070706	1	
	0002	HC00371	MIC jack SCJ-0658-1-Y	2	
	0003	MJ00942	fixed bracket CS12/600 V1.3	2	
	0004	HC00949	speaker socket-RS-C LD4015	2	
	0005	HA04876	wire-RS 4P 160*2/150*2mm UL1015 16AWG	1	AMP OUTPUT
	0006	AC00179	tin without lead-RS M705E Sn 3Ag-0.5Cu	0.414	
0103		HK09187	PC board P-APM200SPEAK	1	
	0001	HB02230	PCB-RS APM120SPEAK VER070706	1	
	0002	HC00371	MIC jack SCJ-0658-1-Y	2	
	0003	MJ00942	fixed bracket CS12/600 V1.3	2	
	0004	HC00949	speaker socket-RS-C LD4015	2	
	0005	HA05120	wire-RS 4P 220*2/300*2mm UL1015 16AWG	1	
	0006	AC00179	tin without lead-RS M705E Sn 3Ag-0.5Cu	0.414	
0104		HK07707	PC board P-APM120-OUTPUT CN	2	
	0001	HC00945	terminal block-RS 2ESDCR-02P PH5.08mm	2	
	0002	HC00947	terminal block-RS 2ESDCR-05P PH5.08mm	2	
	0003	HC00077	connector(male) 3P 2.5mm 180°	2	
	0004	HC00174	connector(male) 4P 3.96mm 180°	1	
	0005	HB02257	PCB-RS DIGMOD OUTPUT- JK VER061107	1	
	0006	AC00179	tin without lead-RS M705E Sn 3Ag-0.5Cu	0.7236	
0105		HA05130	wire-RS 320mm UL1015 18AWG	1	
0106		NF02919	user manual-RS APM200 ALTO V1.1	1	
	0001	NH00149	paper 889*640mm	0.875	
0107		HE00144	fan-RS DC24V/3000RPM 80*80*25mm 150mm 2.5 3P	1	