

Service Manual

MODEL: AU-800R/800H/800P

CONTENT

1. INTRODUCTION.....	1
2. TECHNICAL SPECIFICATION.....	2
3. BLOCK DIAGRAM.....	4
4. SCHEMATIC DIAGRAM.....	7
5. WIRING DIAGRAM.....	12
6. PCB LAYOUT.....	14
7. TEST PROCEDURE.....	20
8. EXPLODED VIEW & MECHANICAL PARTS LIST.....	26
9. BOM.....	32

1. INTRODUCTION

-AU-800R, PLL UHF Diversity Receiver,

- Friendly interface of front panel LCD status display;
- Auto Scan function for easy and convenient operation;
- Switching diversity control to receive the RF signal;
- Three output level versions;
- Squelch control;

-AU-800H/800P transmitters,

- Soft touch painting for comfortable use;
- Rechargeable battery design;
- Three RF output power versions;
- Mute function;
- Lock function to avoid the misaction during the live applications;

-Common features,

- PLL synthesized design;
- Consistent operating frequencies to comply with the EMC regulations;
- Up to 12x12, total 144 channel frequency presets;
- Manufactured under ISO9000:2000, ISO/TS16949:2002 quality management system;

2. TECHNICAL SPECIFICATION

MODEL	AU-800R
Channel	Multi-channels, up to 144 frequency presets for each frequency bands
Frequency band	UHF 470-900 MHz Dependent on applicable country regulations
Receiver type	PLL UHF SYNTHESIZED
Frequency response	50 Hz-15KHz (3dB)
Frequency stability	±0.005% (-10 -50)
T.H.D.	1KHZ 0.8%
Modulation mode	FM (F3E)
S/N Ratio	>90dB
Dynamic	>100dB
RF sensitivity	-100 dBm/30dB SINAD
Audio output	Unbalanced 6.3mm phone jack 550mV ; ±20KHz deviation
Power supply	DC 15V/ 500mA (AC 115V/230V 50/60Hz adaptor)
Dimensions	210(W) 55 (D) 44(H)mm; (8.2" 6.1" 1.7")
Weight	0.99Kg

MODEL	AU-800H	AU-800P
SPECIFICATION		
Oscillation mode	PLL UHF SYNTHESIZED	
Carrier frequency band	UHF 470-900 MHz Dependent on applicable country regulations	
Frequency response	50 Hz-15KHz (± 3 dB)	
Frequency stability	$\pm 0.005\%$ (-10°C ~ 50°C)	
T.H.D.	1KHz < 0.8%	
Modulation mode	FM (F3E)	
RF output power	5-50mW(adjustable 3 bands)	
Dynamic	> 100dB	
Tone frequency	30-33 KHz	
Current drain	100mA	
Max. Deviation	± 35 KHz	
Battery	"AA" type $\times 2$	
Optional	Nickel hydrogen battery +charger	
Mic. Capsule(optional)	Condenser or Dynamic Capsule	Condenser or Dynamic Capsule
Dimensions	277 \times Φ 36.5mm (10.9" \times Φ 1.44")	97mm \times 68mm \times 22mm(3.82" \times 2.68" \times 0.87")
Weight	0.246Kg	0.009Kg

AU-800R

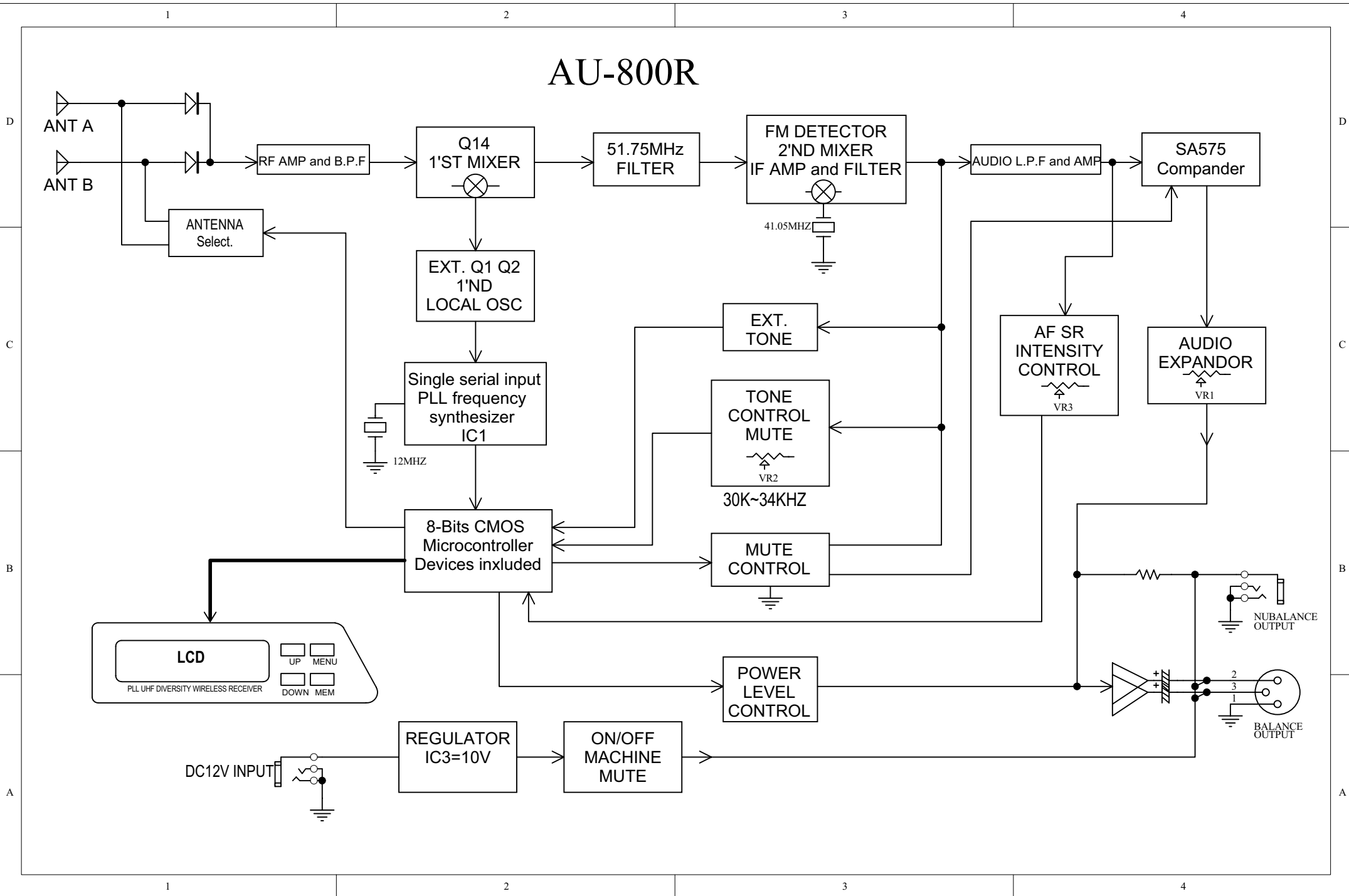

AU-800H

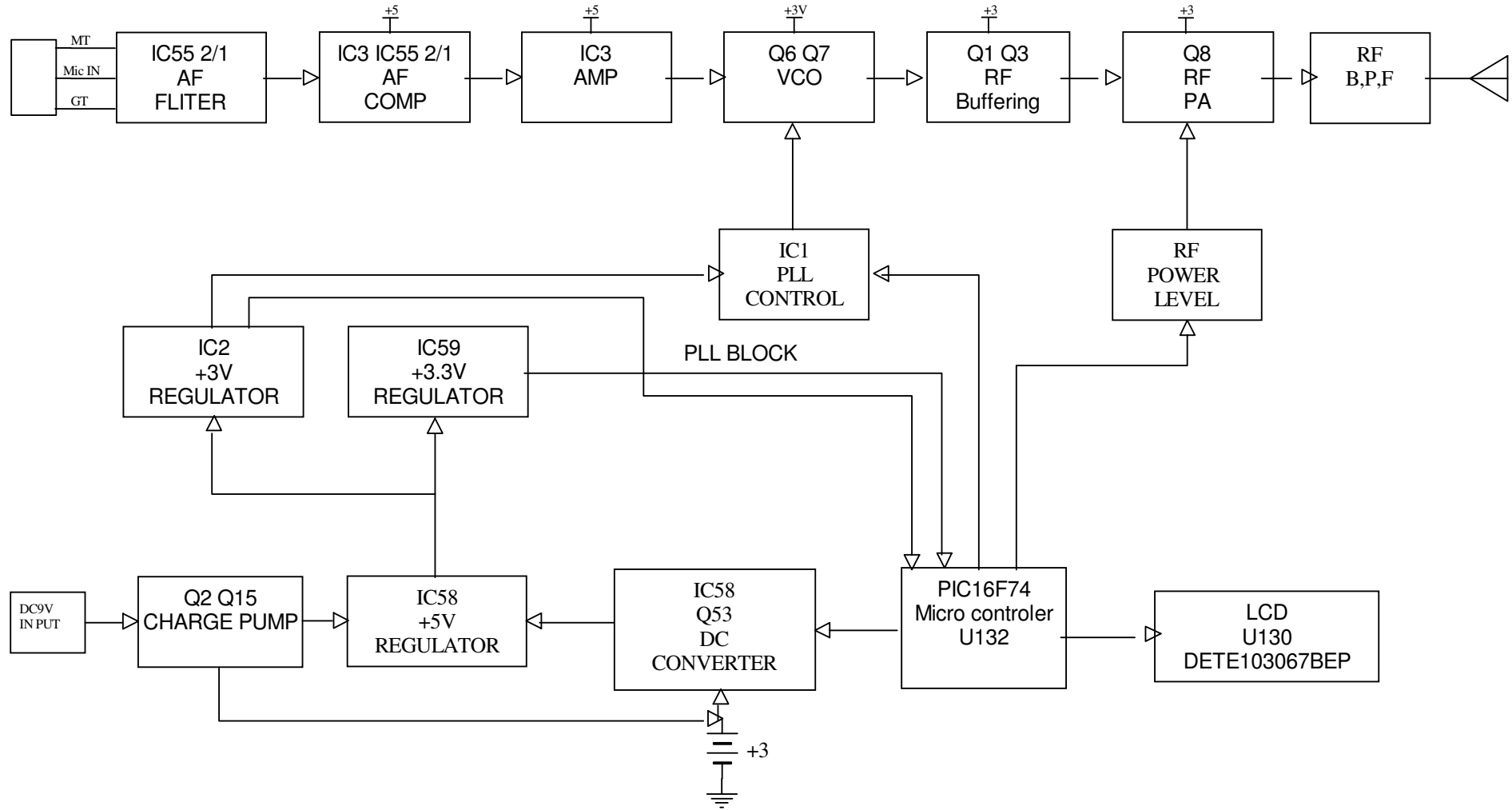

AU-800P

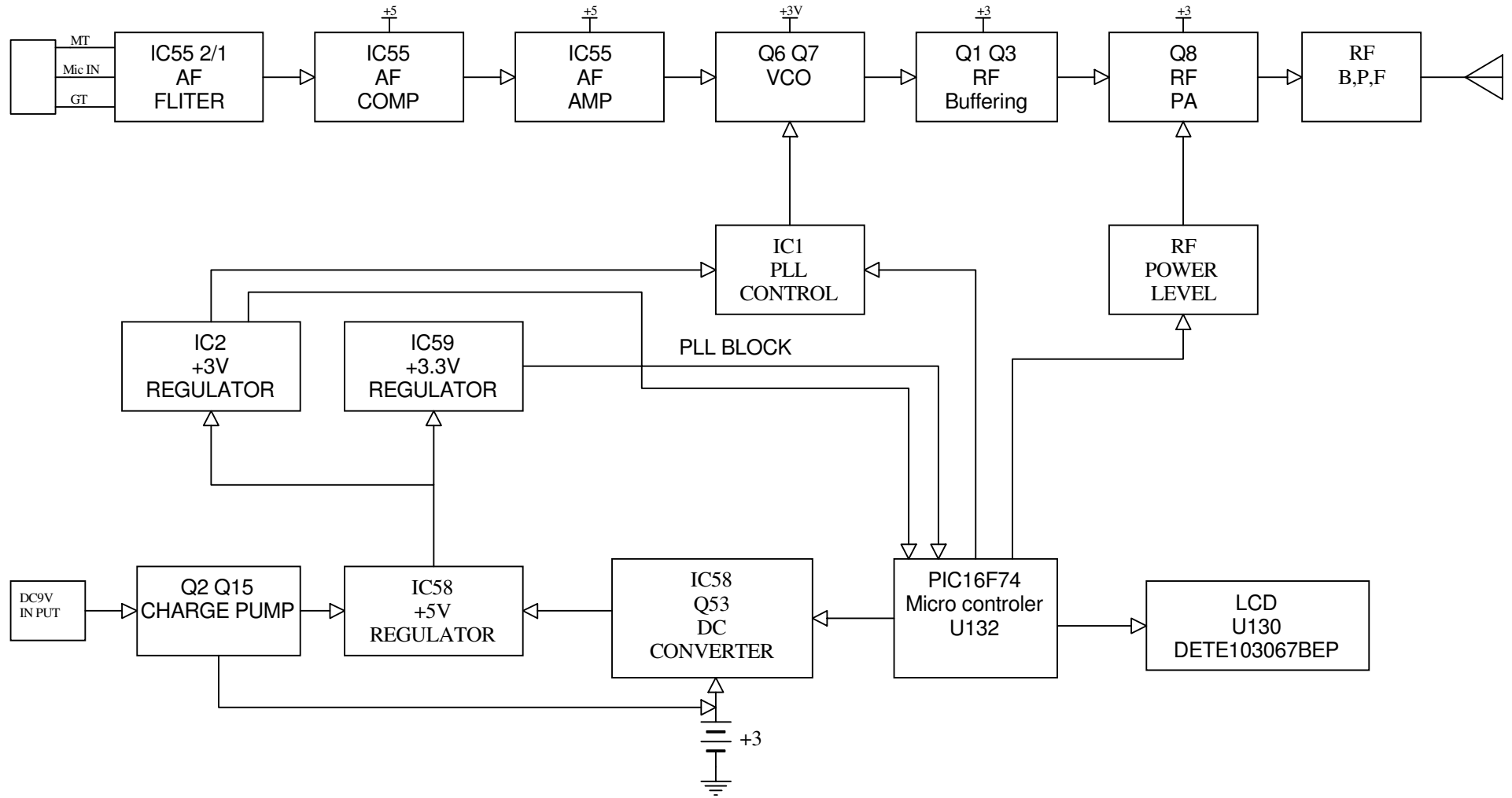

4. SCHEMATIC DIAGRAM

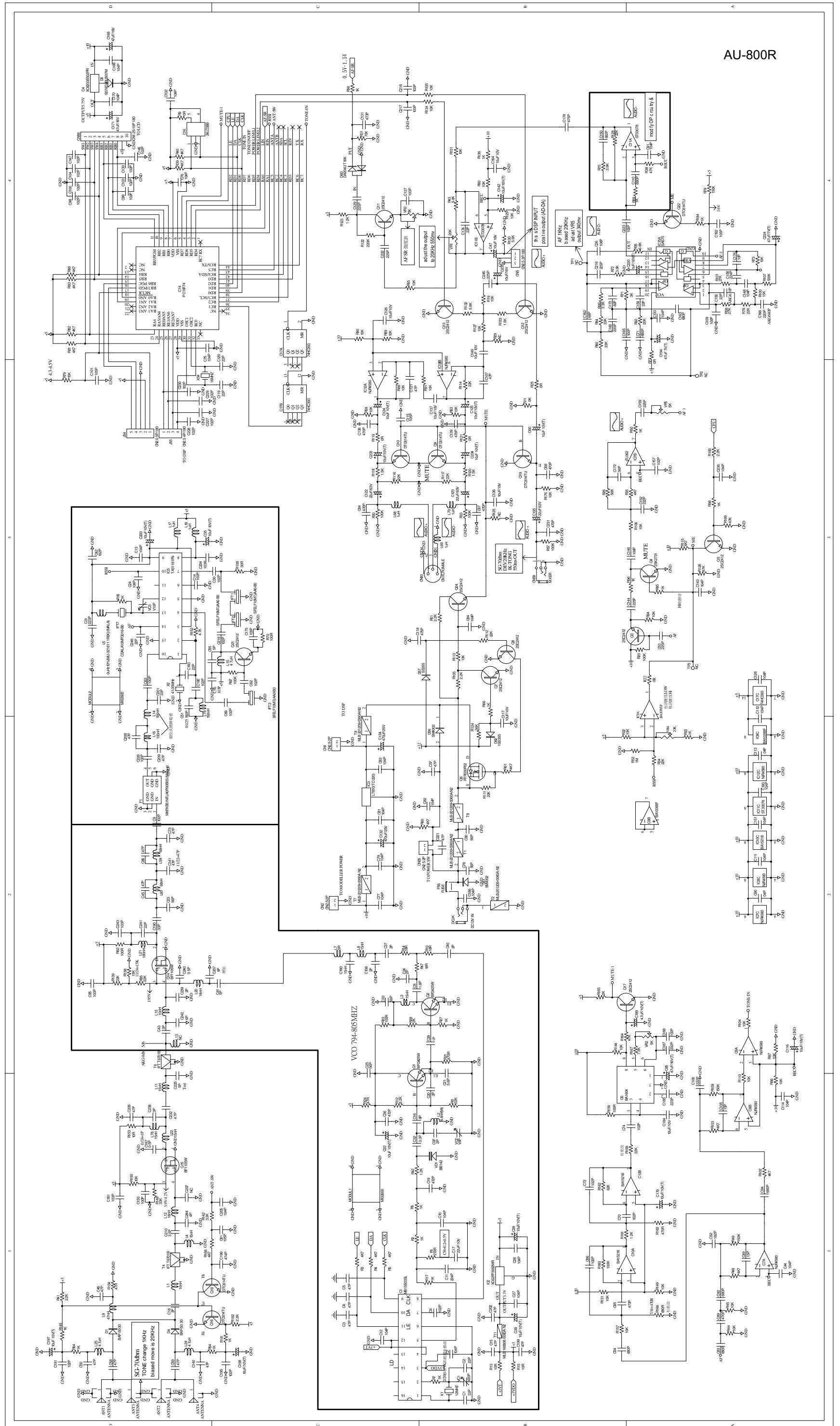

AU-800R

AU-800R-LCD

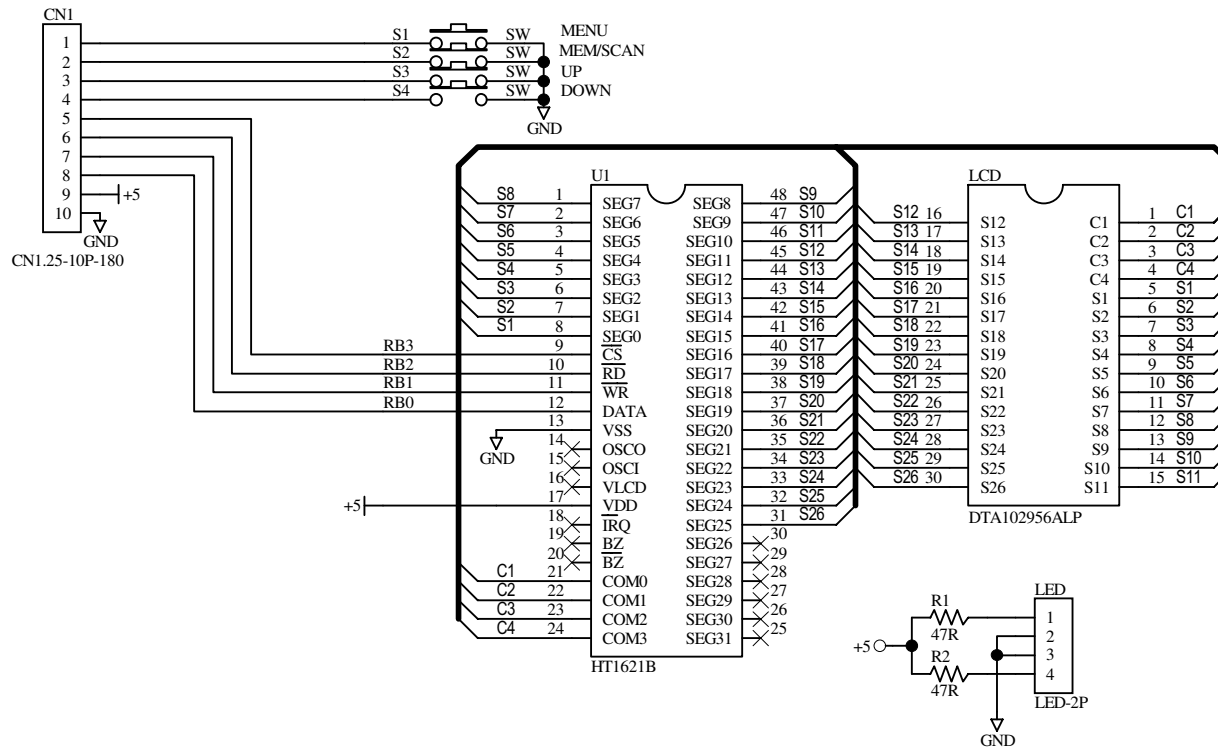

- 8 -

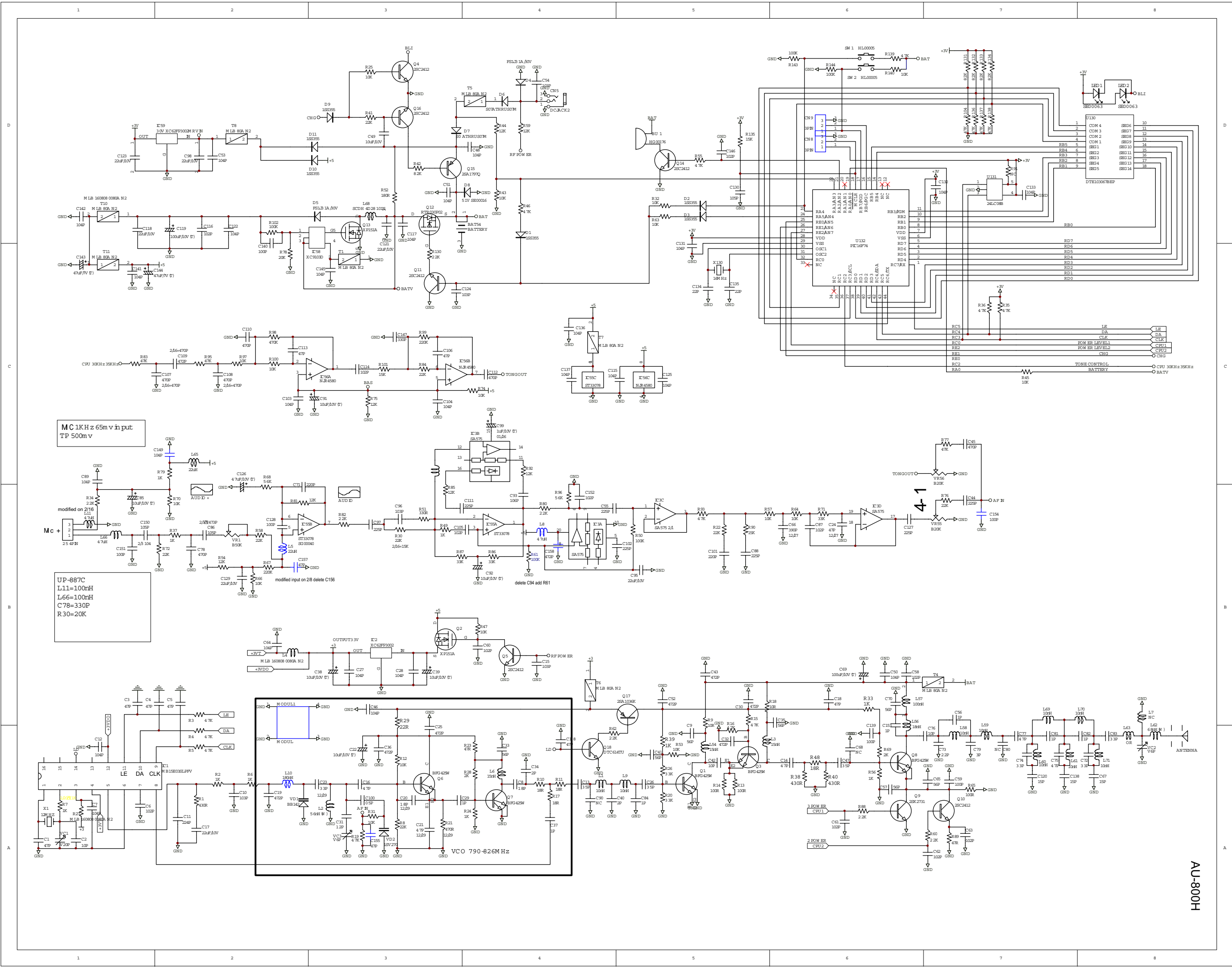

AU-800H

AU-800P

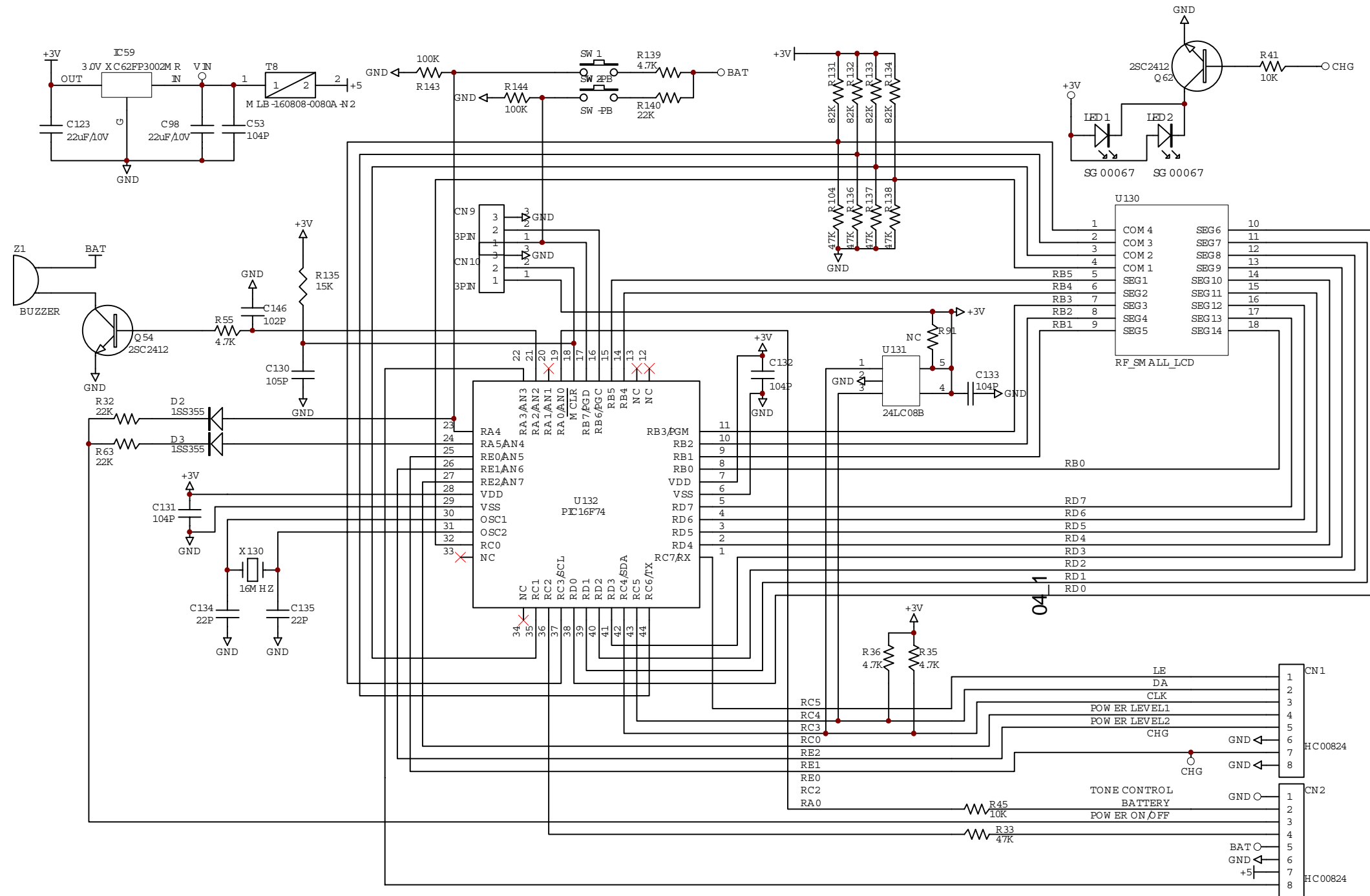

5. WIRING DIAGRAM

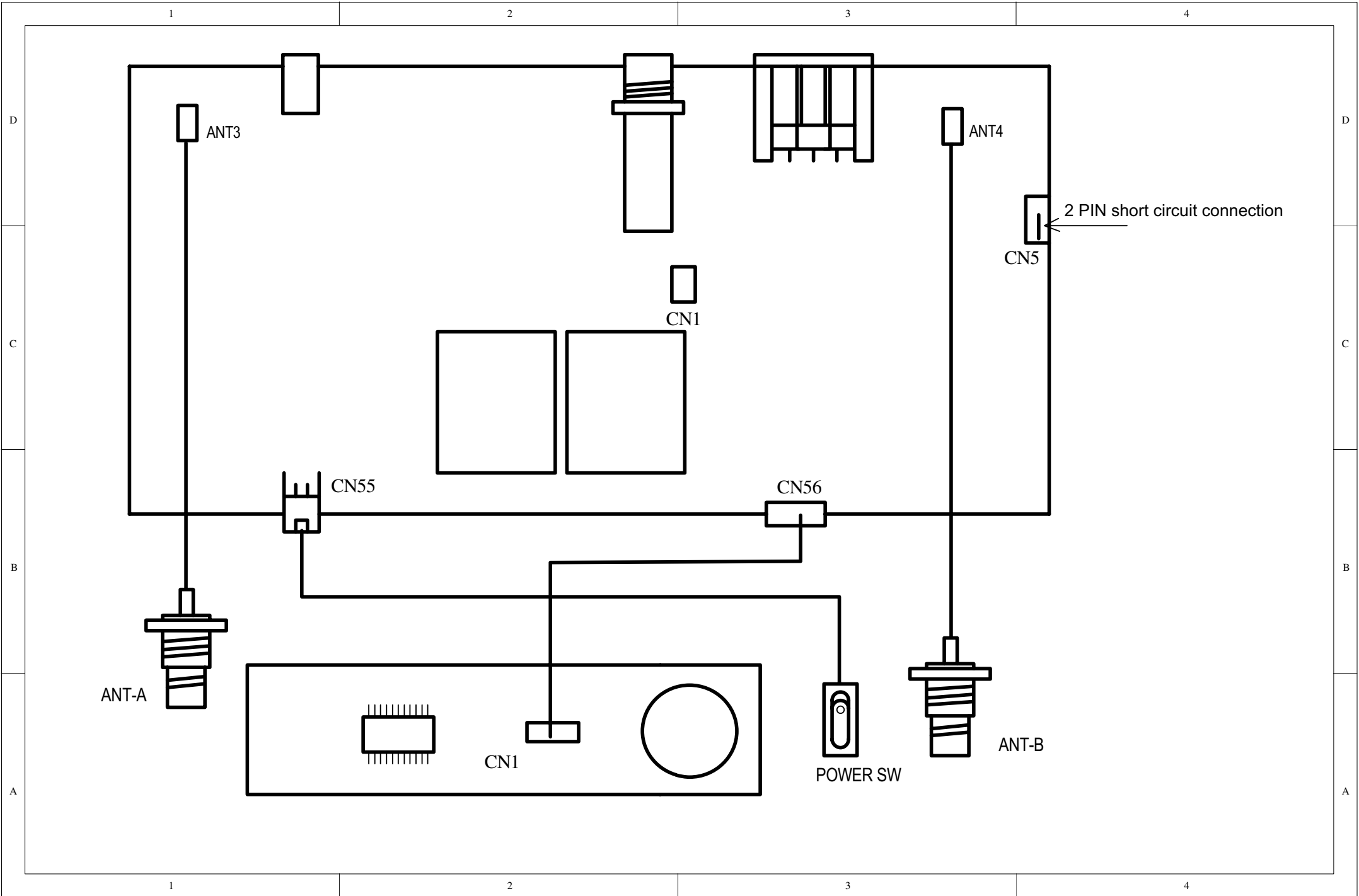

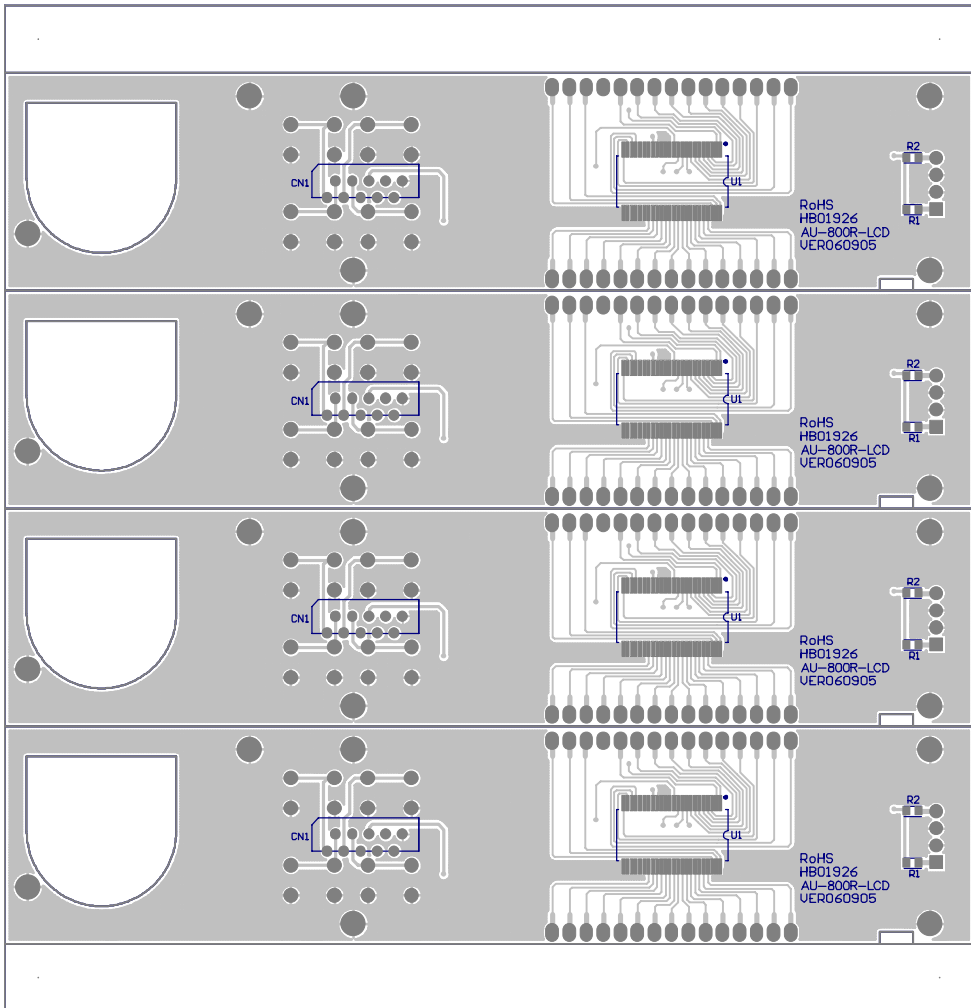

PCB:AU-800R-LCD Bottom Layer Bottom Overlay Bottom Solder

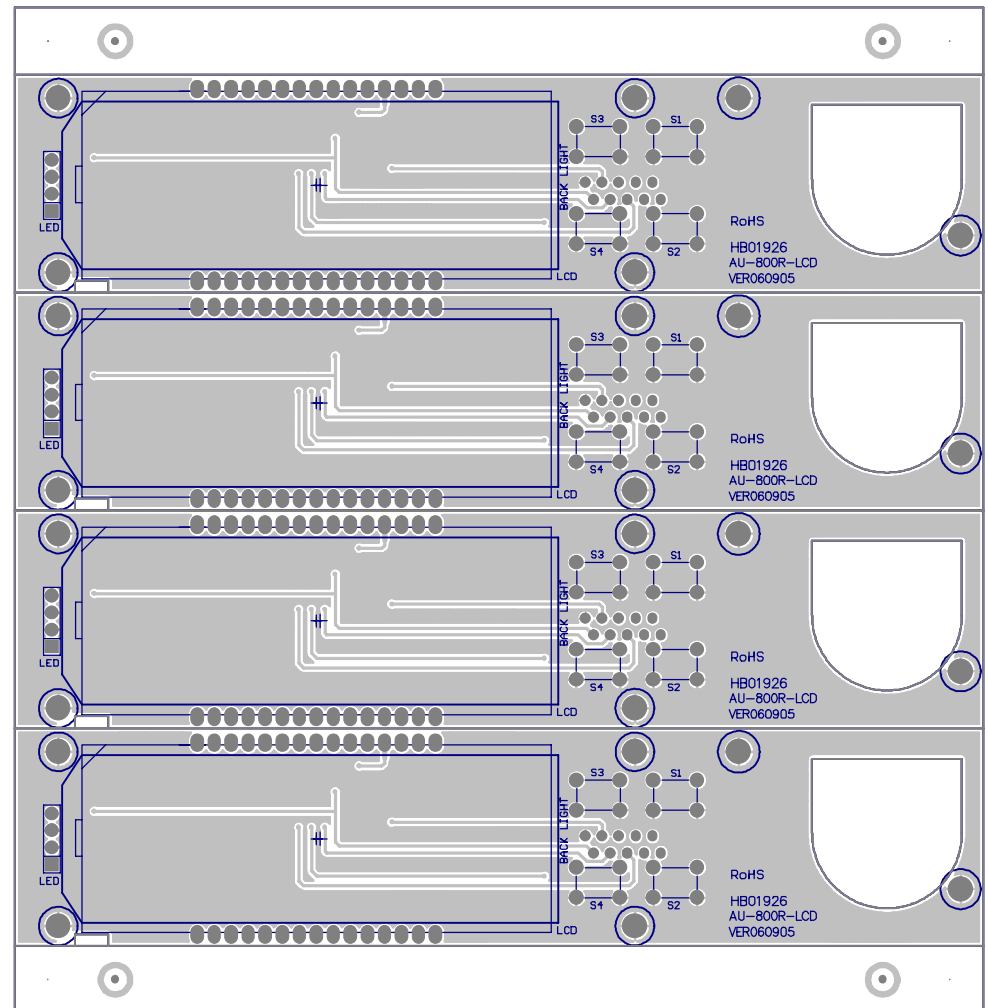

PCB:AU-800R-LCD Top Layer Top Overlay Top Solder

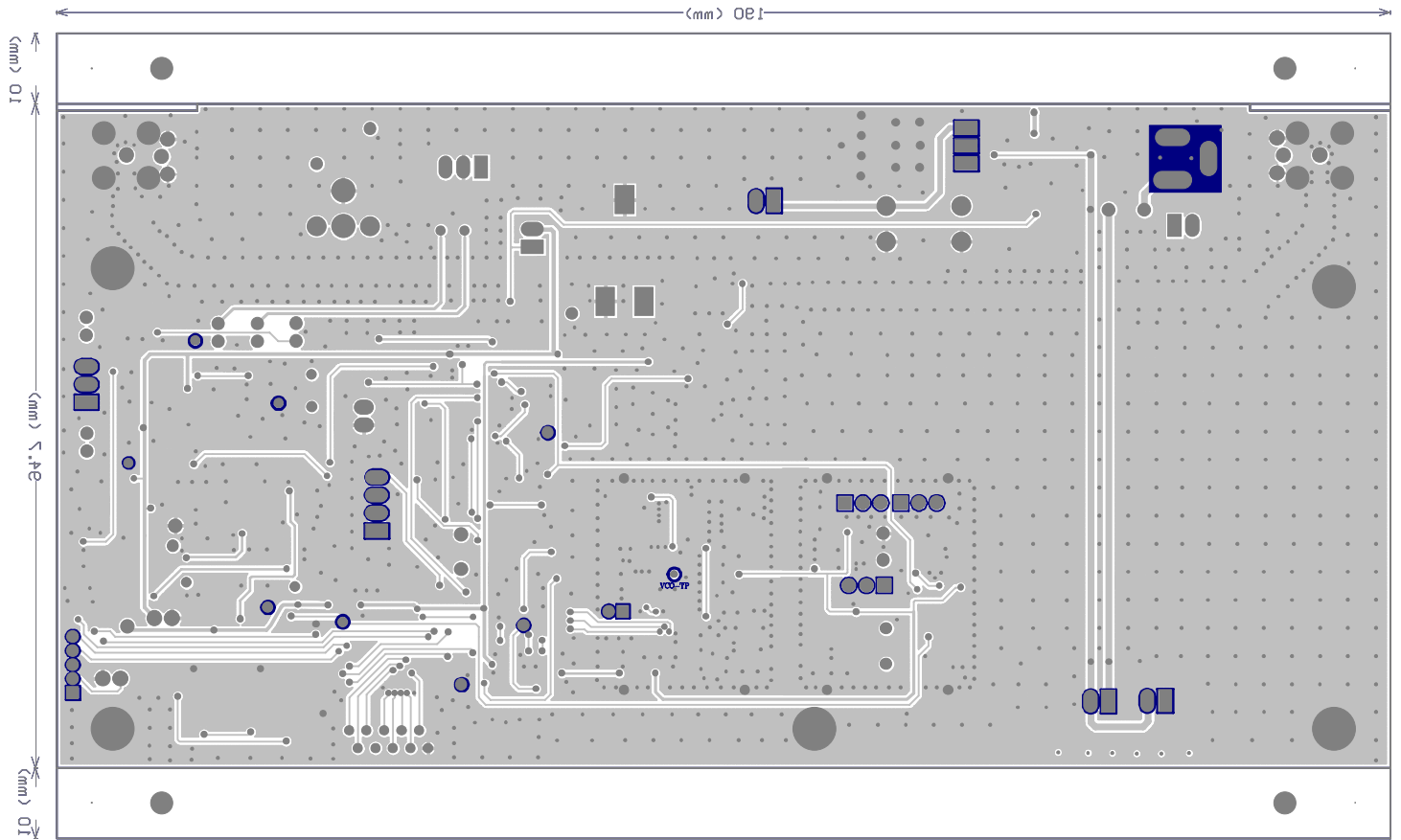

PCB:UP-8DR-RX-V2 Bottom Layer Bottom Overlay Bottom Solder

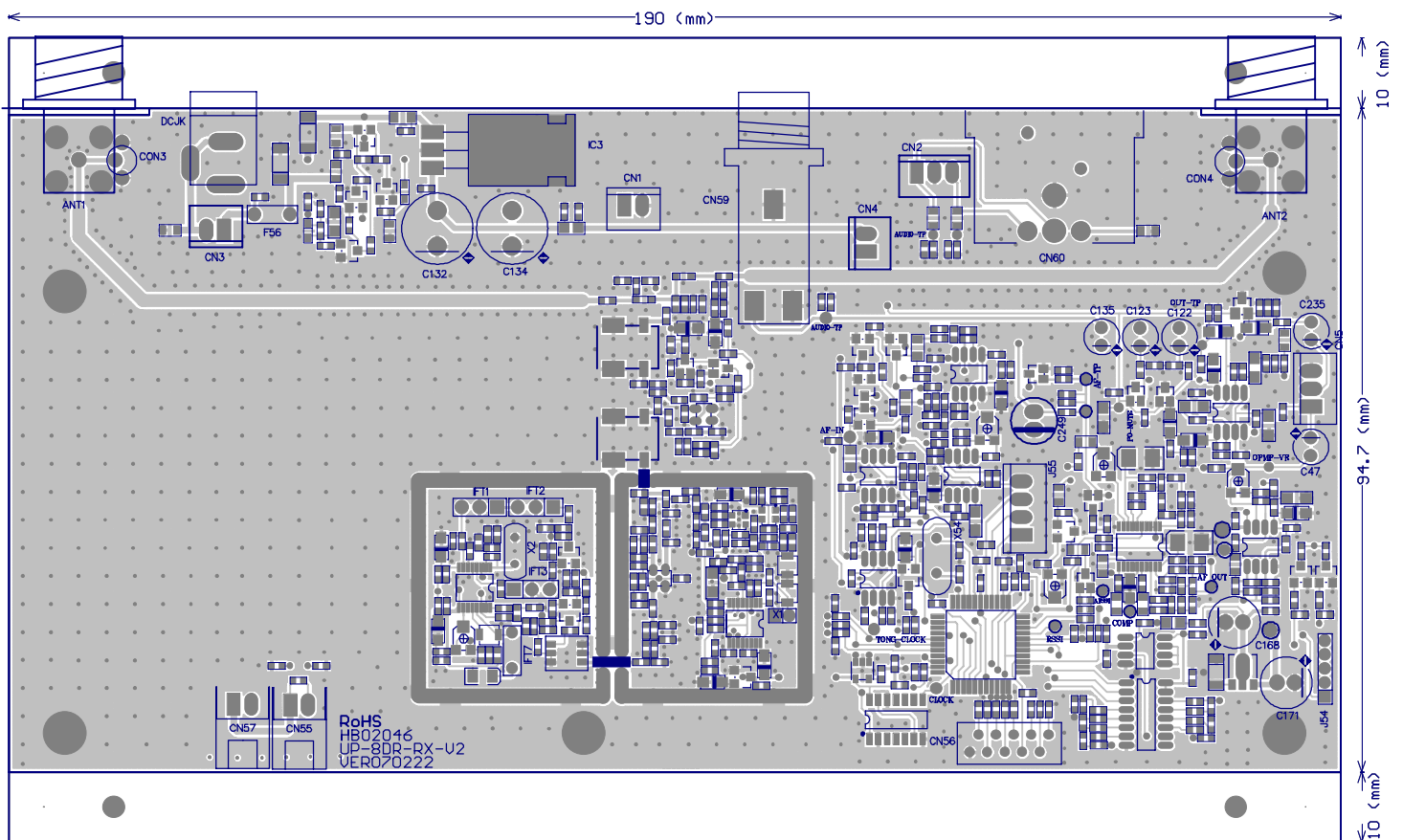

PCB:UP-8DR-RX-V2 Top Layer BTop Overlay Top Solder

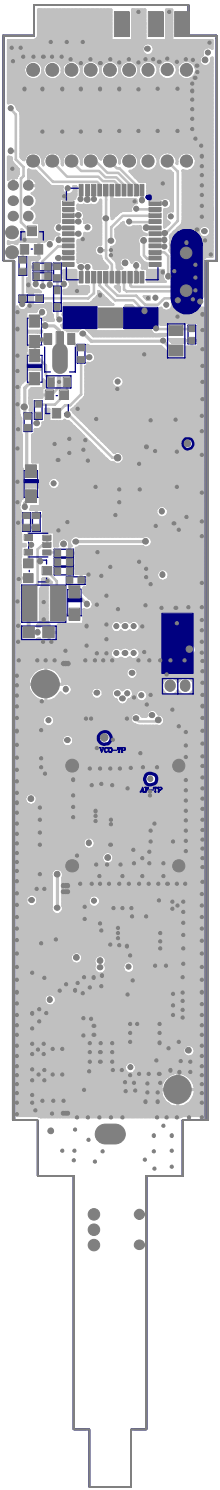

PCB:UP-8H-V2
 Bottom Layer
 Bottom Overlay
 Bottom Solder

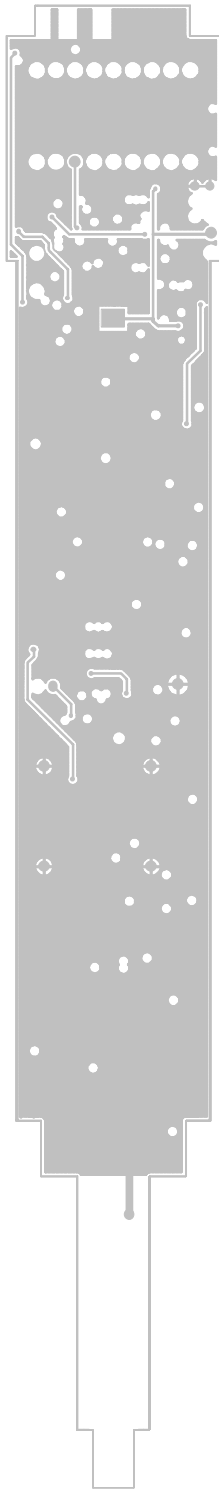

PCB:UP-8H-V2
 Ground Plane

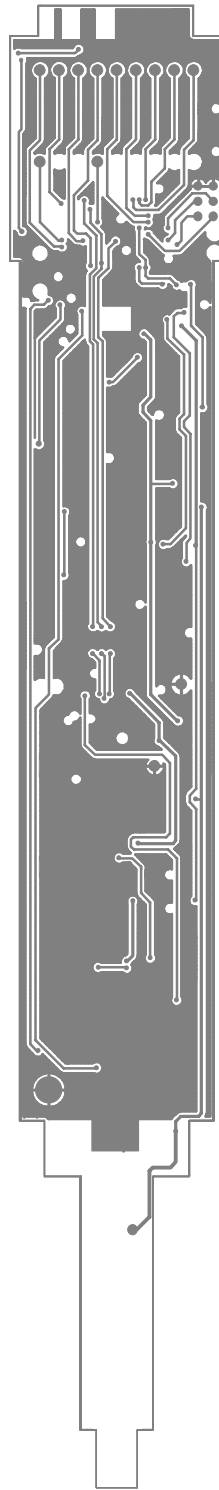

PCB:UP-8H-V2
 Power Plane



PCB:UP-8H-V2
 Top Layer
 Top Overlay
 Top Solder

RoHS
 UP-8H-U2_VER061018
 HB02047

AU-800H

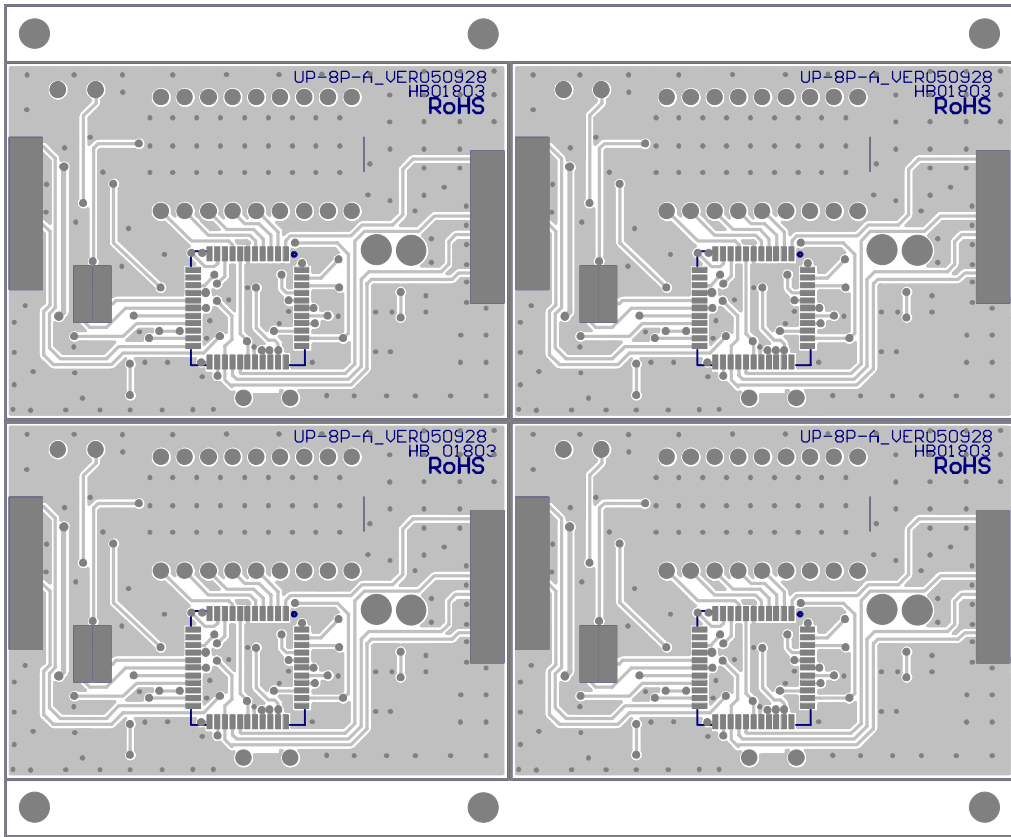

PCB:UP-8P-A Bottom Layer Bottom Overlay Bottom Solder

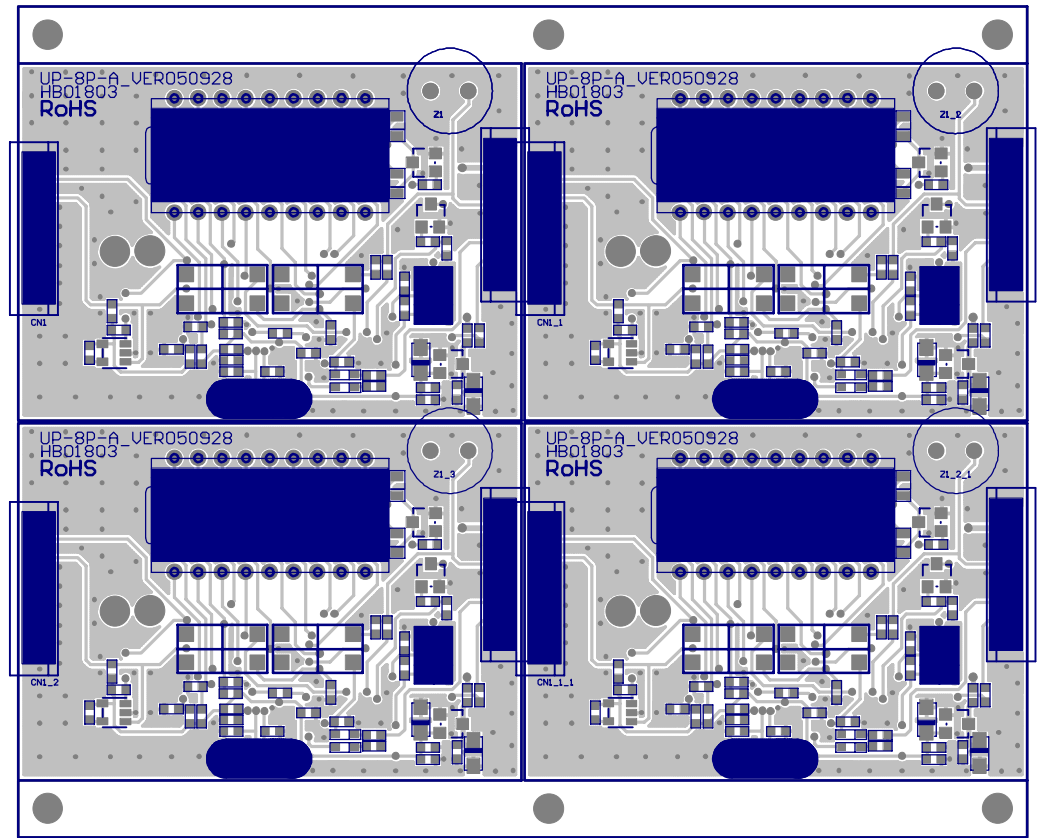

PCB:UP-8P-A Top Layer Top Overlay Top Solder

PCB:UP-8P-B
Power Plane

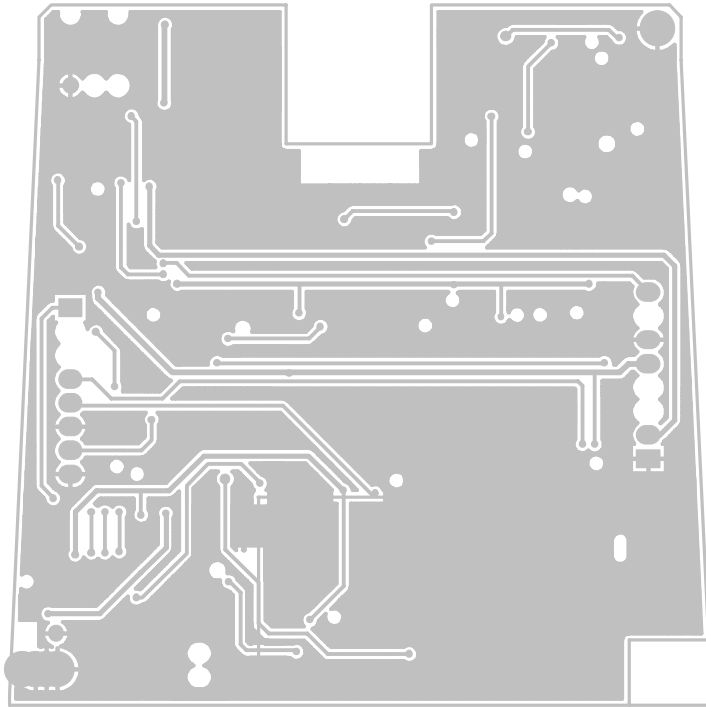

PCB:UP-8P-B
Ground Plane

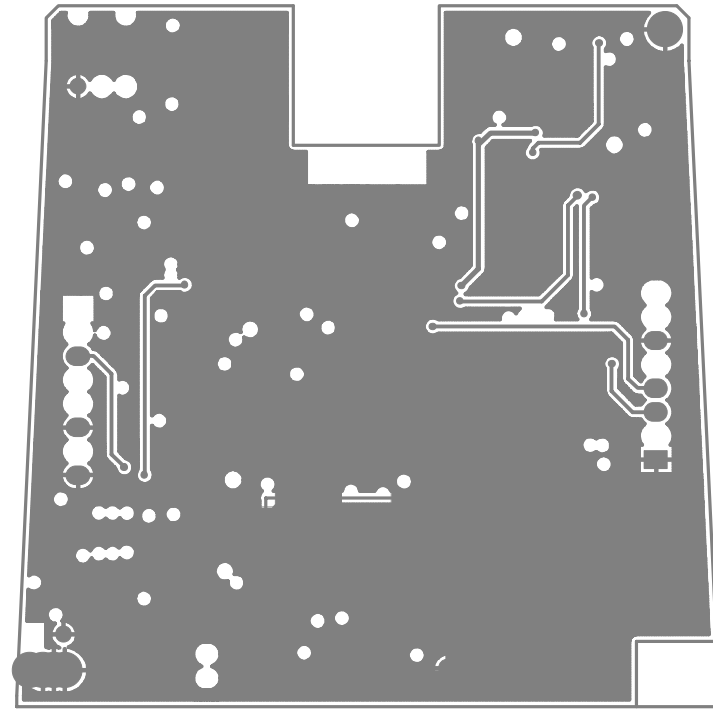

PCB:UP-8P-B
Bottom Layer
Bottom Overlay
Bottom Solder

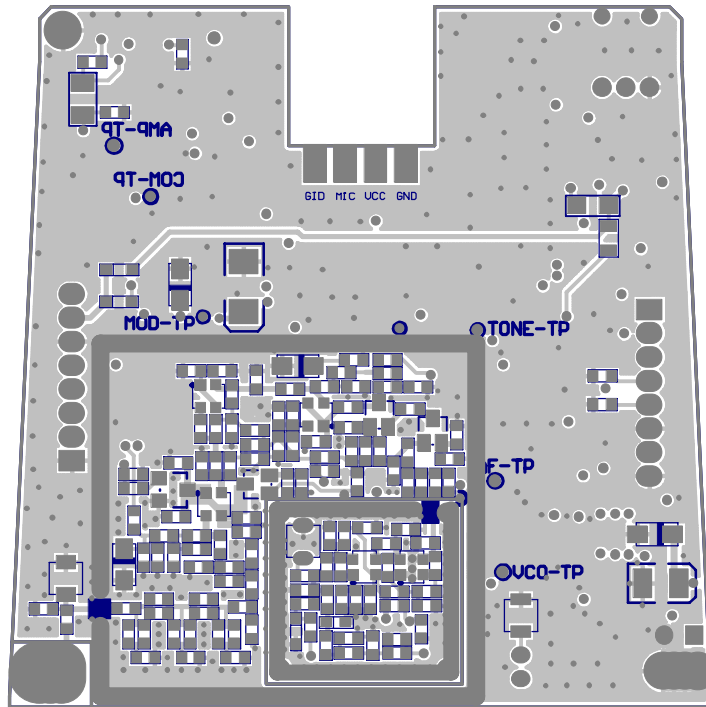

PCB:UP-8P-B
Top Layer
Top Overlay
Top Solder

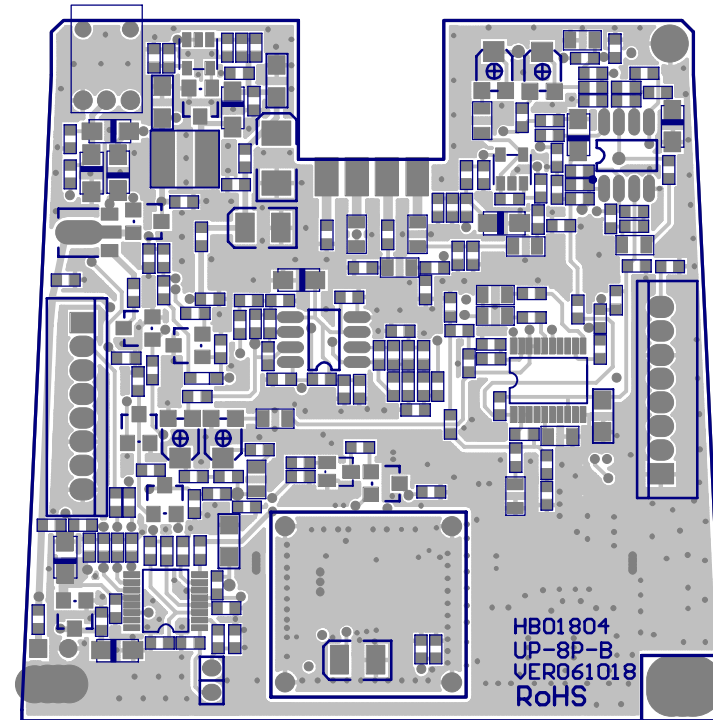

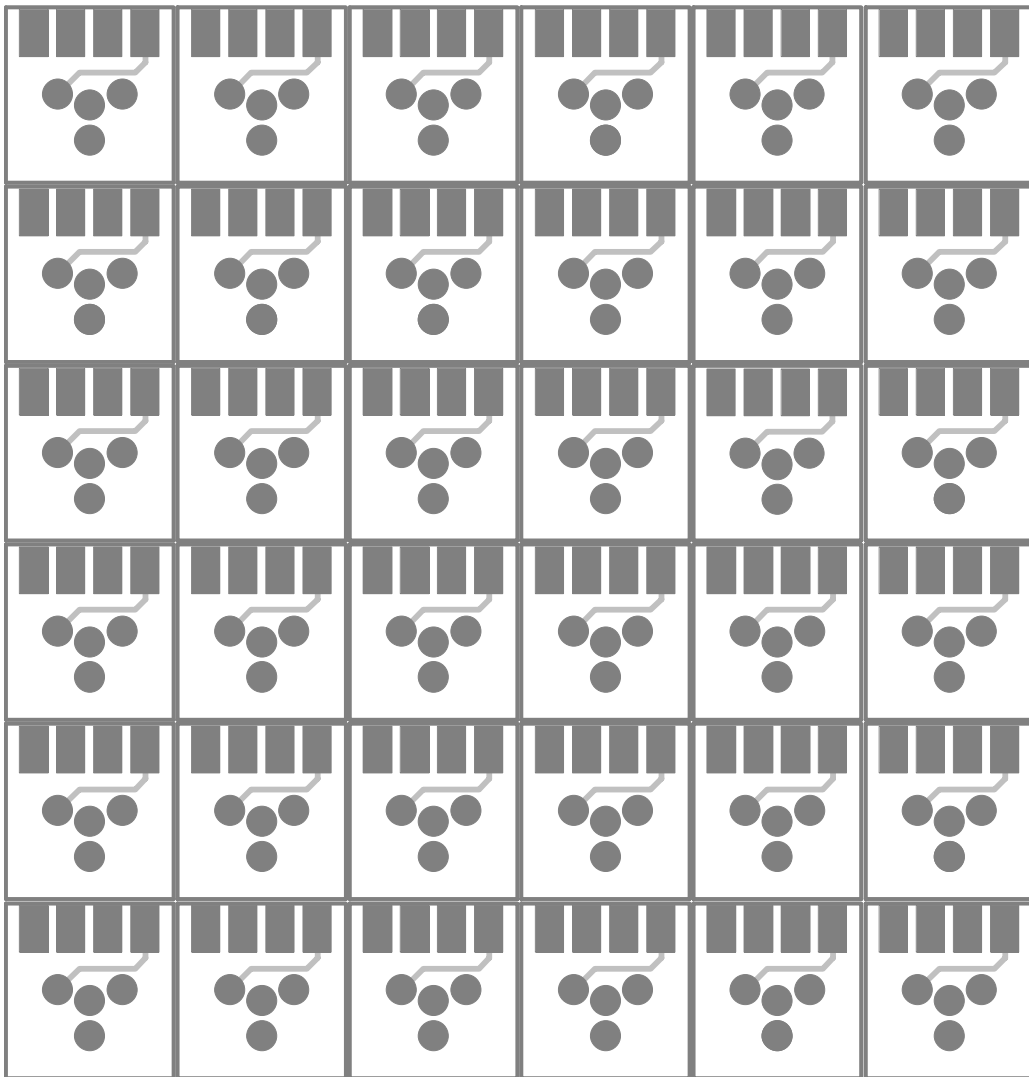

PCB:UP-8P-MIC Bottom Layer Bottom Solder

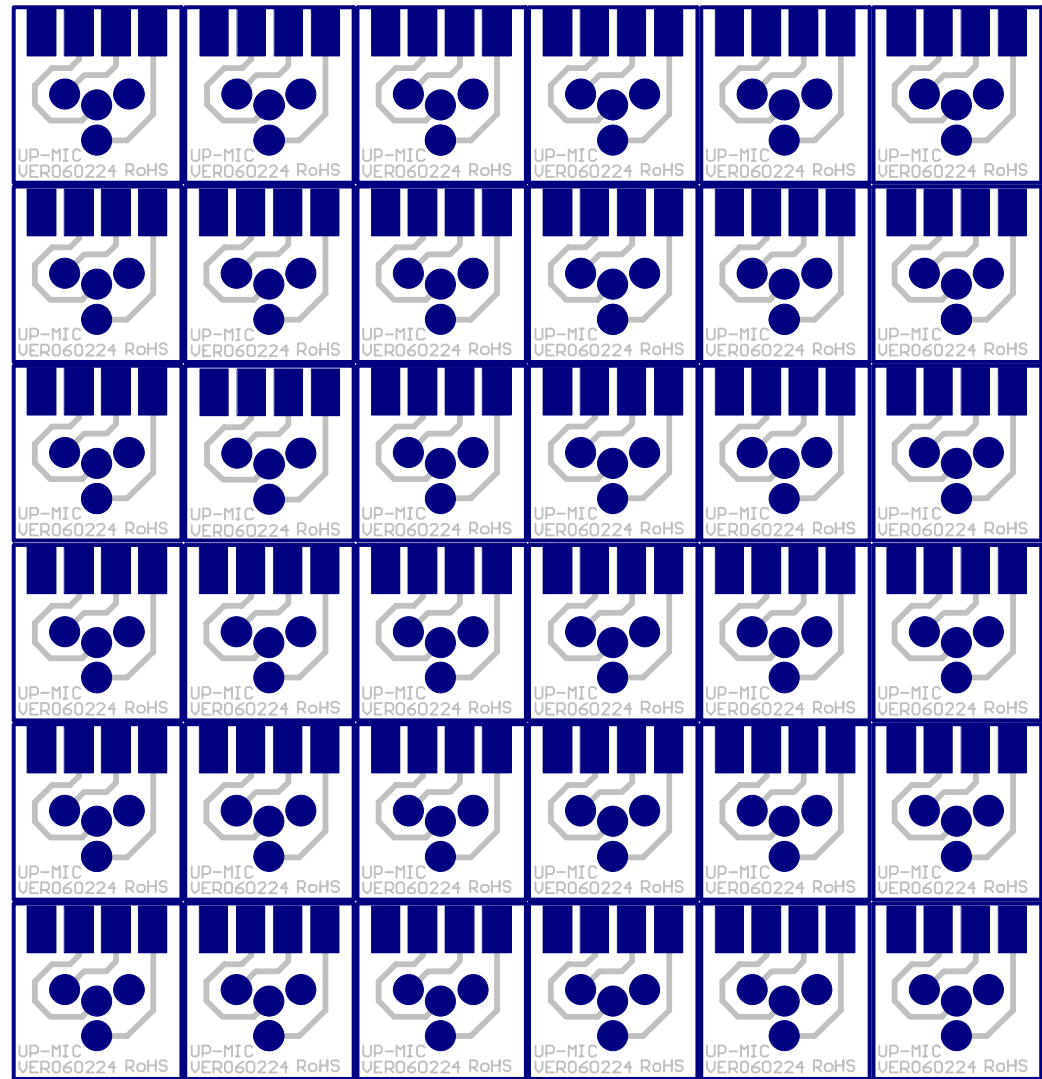

PCB:UP-8P-MIC Top Layer Top Solder

7. TEST PROCEDURE

AU-800R

Instruments:

1. DC supplier: 12V (adjustable)
2. High frequency signal generator: E4420B
3. Oscilloscope: LS8106.
4. Audio analyzer: 8903B

Instruments Setting:

1. High frequency signal generator: E4420B
Depth/dev: 20KHZ Rate:1KHZ
Waveform: Dual-sine FM/Tone 2Rate:32.768KHZ
AMPLITUDE: -80dBm FM Tone 2Amp percent of peak:10%
2. Power supply: DC12V/300mA

Test procedure and specification:

1. AF output: when the induction is in 0~-80 dbm, the THD is 0.8%
2. AF out is 550mV±50mV.
3. Test the parallel output in PL0: is 1.1V±100mV
PL1: 575mV±50 mV
PL2: 250mV±50 mV
4. Frequency response test: on the basis of 1KHZ, 100Hz is 1.5±1db, 10KHZ is -13±1.5db.
5. TONE signal test: change FM/Tone 2Rate:32.768KHZ, the RF can turn on in 30.2KHZ~34KHZ.
(Note: when TONE signal is 31.7KHZ, the battery is full; when the TONE signal is 32.768KHZ, the battery has 2 segments; when the TONE signal is 34KHZ, it display low battery status).
6. AF level test, when the first light is 6KHZ±2KHZ, it will light up, and will fully light up in 11±2KHZ.
7. RF level test, the first light will light up below -95dbm, and will fully light up in -65dBm.
8. Test the induction of A, B when it is difference 2dBm, the induction of CH1~CH12 is 6dbm.
9. Adjust the MENU key, when it is in MUTE mode, adjust the UP and DOWN, the AF has no output.
10. Adjust the MENU key, when the SQ is in 1, the induction of SQ is below -95dBm; when the SQ is in 10, the induction of SQ is below -65dBm.
11. SCAN function test: it will transmit fixed frequency from signal generator, press the MENU for 1.5 seconds to scan, when scan to the transmitted frequency, the RF light will

blank, after press the MENU to lock, it has the output.

(Note: the Channel on Group 1~8 only scan for 1~11; the Group 9~12 only scan 1~10.

12. LCD test:

Group 1 Channel 1 RF display in LCD AF display in LCD

12.1. ANT.A display 798,000MHZ, the battery status is full.

12.2. Press MENU key, it will appear Group, Channel, PL, UNNU, and SI 1. in return.

12.3. Press the MENU key, it will display Group, up and down have corresponding variation, at last, press the MENU key to lock, and it will appear static condition.

12.4. When the signal from ANT.A input, the LCD display the ANT.A, the signal from ANT.B input, the LCD display ANT.B.

12.5. During press the key, check if the LCD will appear abnormal problem, and it has corresponding variation.

13. Turn on and down the unit for 3 times, the unit should without the crashed problem. The display will be decreased for 2-3 seconds in delay.

14. The consumption current is less than 230mA.

15. SQ factory presets: set in 5 condition

AU-800H

Instruments:

1. signal generator: 8903b
2. oscillograph: LS8106
3. modulator: JMM-2200
- 4: frequency recorder: EFC-3203A
5. DC power supplier: 3303A.
6. multi-meter
7. frequency spectrum: E4403B

Instruments Setting:

1. signal generator: 1kHz/65mV.
2. modulator:
 - 2.1. Tone set: H: Pass: 3K L: Pass: 50K RANGE: 10
 - 2.2. AF set: H: Pass: 25 L: Pass: 15K RANGE: 50

Test procedure and specification:

1. Turn on the power supply (press the ON/OFF key for 2 seconds), the LED indicator will light up, after the LCD show the battery and frequency status, the bright of LED indicator will be decreased.
2. Test the sense power of PL2 on CH1, CH6, CH12 are above 5dBm, the sense power of PL1 is above 1dBm, the sense power of PL0 is above -5dBm, and the harmonics is below -45dBm. (note: the power of PL1/PL2/PL0 must have obvious variation)
3. Input signal from MIC input terminal (shout), the modulator should have output.
4. Tone test: Tone signal is in 3KHZ \pm 0.5KHZ, the frequency is in 31~34KHZ.
5. Test that the radio frequency is in standard range, permit the error in \pm 2KHZ.
6. Functions test:
 - 6.1. Switch the CH/ON key to corresponding channel, and the SELECT has corresponding variation.
 - 6.2. Switch the CH/ON key to Lock, the SELECT functional key will be useless; it need

switch to UN Lock, the SELECT key can work normally.

- 6.3. In standby condition, press SELECT key for 2 seconds, it is in MUTE mode, the entire functional keys will be out of control, the TONE has no output, press the SELECH key for 2 seconds to activate the unit or press the CH/ON to close it.
7. Showing test: when switch the functional key, the display will appear the corresponding variation, and check the display is normal or abnormal.
8. Low voltage test: when it is $2.0V \pm 0.1V$, the display will appear the low voltage; when the voltage is below 2V, the unit will be closed automatically.
9. Total consumption current: when the power is in PL2, the consumption is below 125mA
10. Turn off the power supply (press the ON/OFF for 2 seconds), the LED lights up, after the LCD display CH, the LED light will be decreased.
11. Charge test:
 - 11.1 When the unit is charging, the current is $160mA \pm 40mA$.
 - 11.2 When the unit is charging, the LCD will appear the battery symbol and rotate up and down.
 - 11.3 During charging, the voltage of battery have rise trend. (increase)
 - 11.4 When the unit is charging, the transmitter will stop to transmit the power.
 - 11.5 When the battery is full, the LED will blink.

Note:

1. When the unit is charging, it must be added the load (battery).
2. Please use the professional battery charger.

AU-800P

Instruments:

1. signal generator: 8903b
2. oscillograph: LS8106
3. modulator: JMM-2200
- 4: frequency recorder: EFC-3203A
5. DC power supplier: 3303A.
6. multi-meter
7. frequency spectrum: E4403B

Instruments Setting:

1. signal generator: 1kHz/65mV.
2. modulator:
 - 2.1. Tone set: H: Pass: 3K L: Pass: 50K RANGE: 10
 - 2.2. AF set: H: Pass: 25 L: Pass: 15K RANGE: 50

Test procedure and specification:

1. Turn on the power supply (press the ON/OFF key for 2 seconds), the LED indicator will light up, after the LCD show the battery and frequency status, the bright of LED indicator will be decreased.
2. Test the sense power of PL2 on CH1, CH6, CH12 are above 5dBm, the sense power of PL1 is above 2dBm, the sense power of PL0 is above -4.5dBm, and the harmonics is below -45dBm. (note: the power of PL1/PL2/PL0 must have obvious variation).
3. Input signal from MIC input terminal (shout), the modulator should have output.
4. Tone test: Tone signal is in 3KHZ \pm 0.5KHZ, the frequency is in 31~34KHZ.
5. Test that the radio frequency is in standard range, permit the error in \pm 2KHZ.
6. Functions test:

- 6.1. Switch the CH/ON key to corresponding channel, the SELECT has corresponding variation.
- 6.2. Switch the CH/ON key to Lock, the SELECT functional key will be useless; it need switch to UN Lock, the SELECT key can work normally.
- 6.3. In standby condition, press SELECT key for 2 seconds, it is in MUTE mode, the entire functional keys will be out of control, the TONE has no output, press the SELECH key for 2 seconds to activate the unit or press the CH/ON to close it.
7. Showing test: when switch the functional key, the display will appear the corresponding variation, and check if the display in normal or not.
8. Low voltage test: when it is $2.0V \pm 0.1V$, the display will appear the low voltage; when the voltage is below 2V, the unit will be closed automatically.
9. Total consumption: when set the power in PL2, the consumption is below 125mA
10. Turn off the power supply (press the ON/OFF for 2 seconds), the LED lights up, after the LCD display CH, the LED light will be decreased.
11. Charge test:
 - 11.1 When the unit is charging, the current is $160mA \pm 40mA$.
 - 11.2 When the unit is charging, the LCD will appear the battery symbol and rotate up and down.
 - 11.3 During charging, the voltage of battery have rise trend. (increase)
 - 11.4 When the unit is charging, the transmitter will stop to transmit the power.
 - 11.5 When the battery is full, the LED will blink.

Note:

1. When the unit is charging, it must be added the load (battery).
2. Please use the special battery charger

8. EXPLODED VIEW & MECHANICAL PARTS LIST

AU-800R

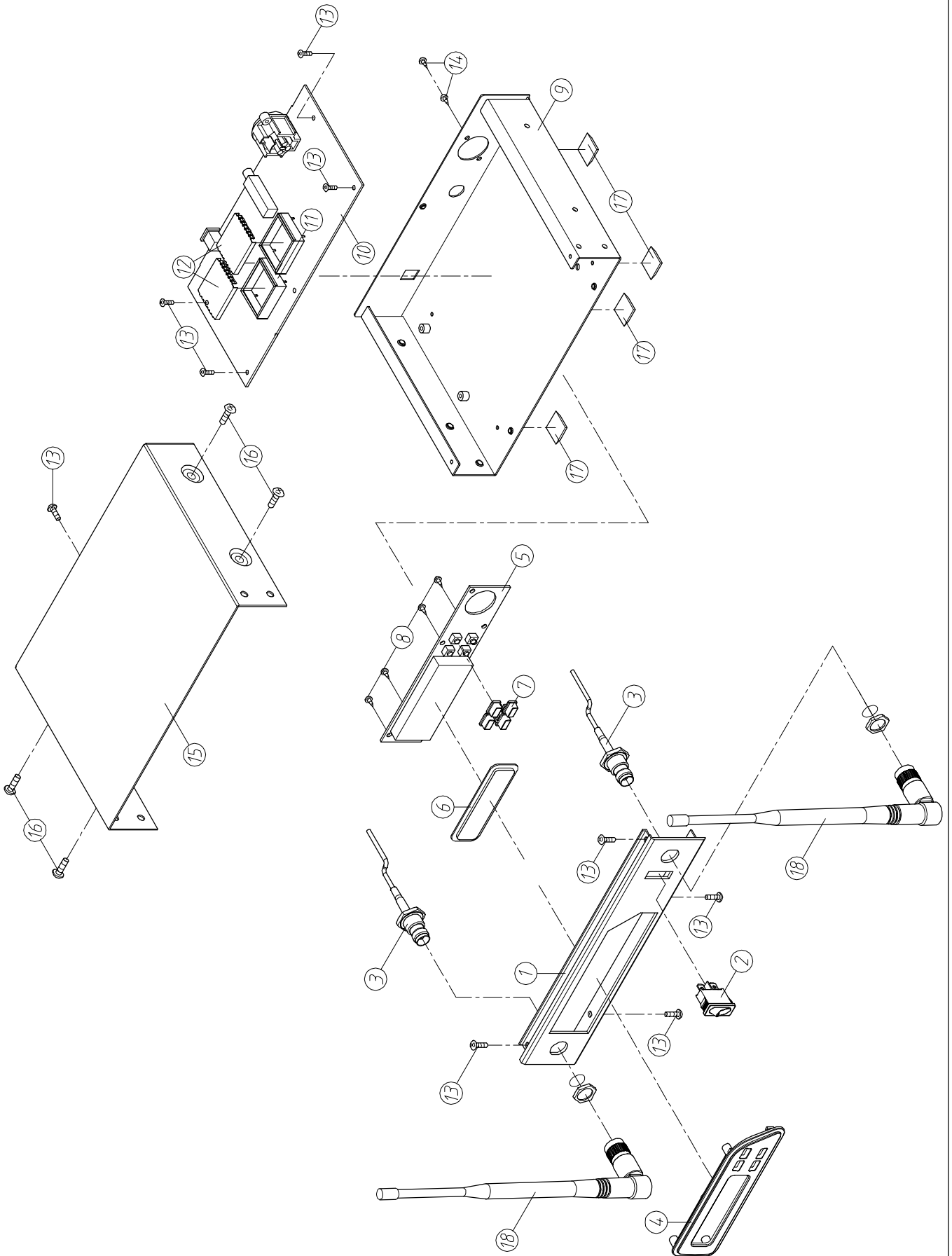

SEIKAKU

SEKAKU

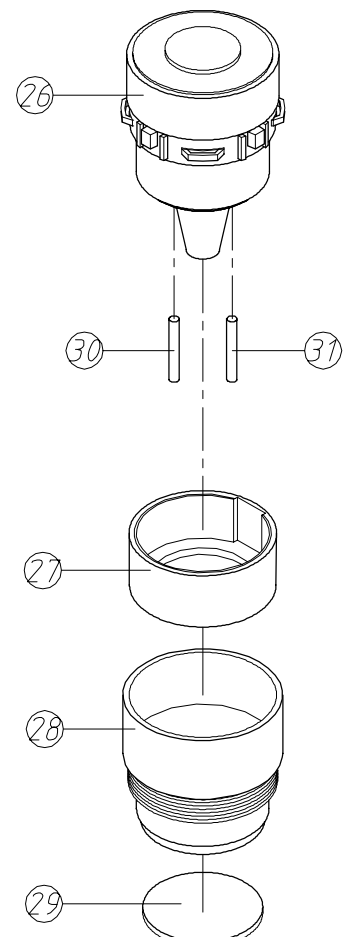
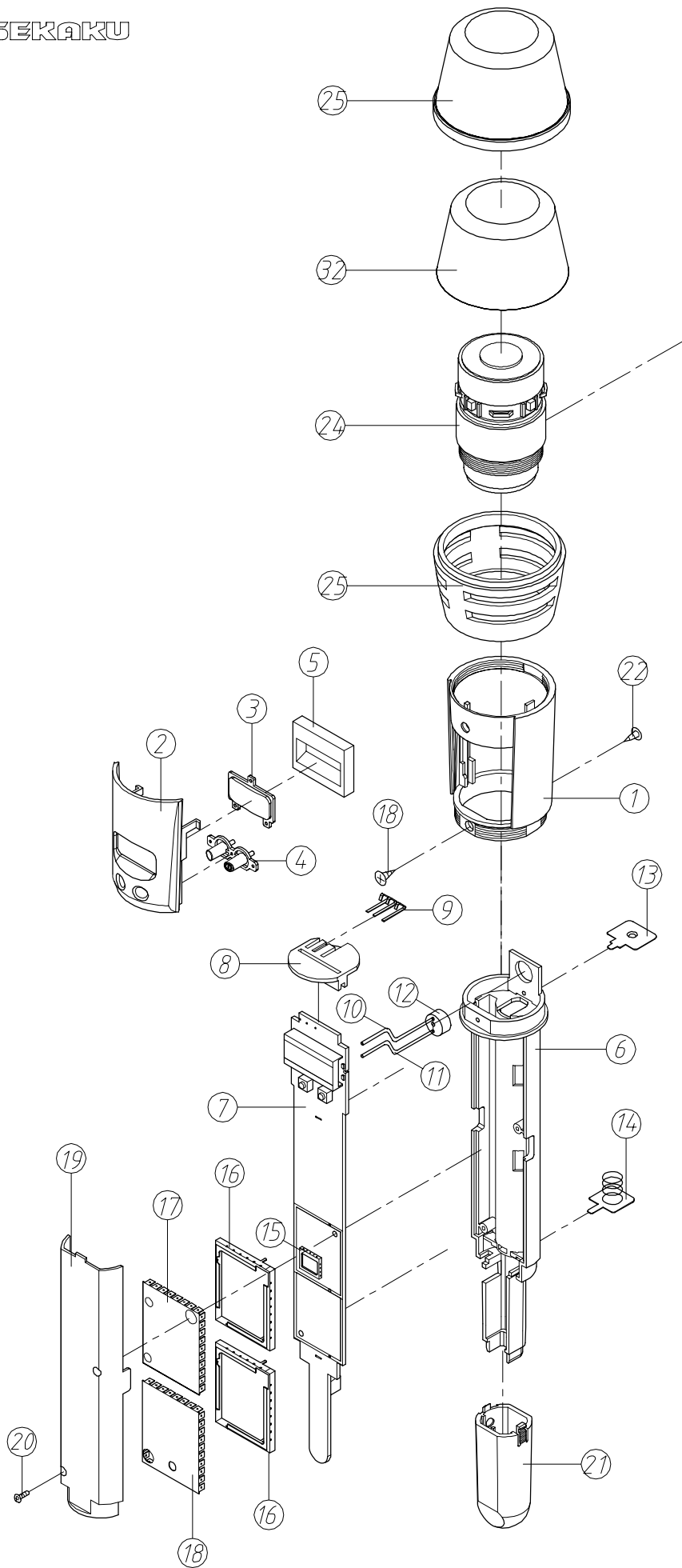

UP-83H

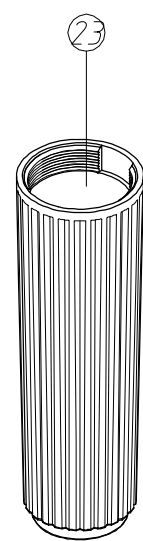

AU-800H

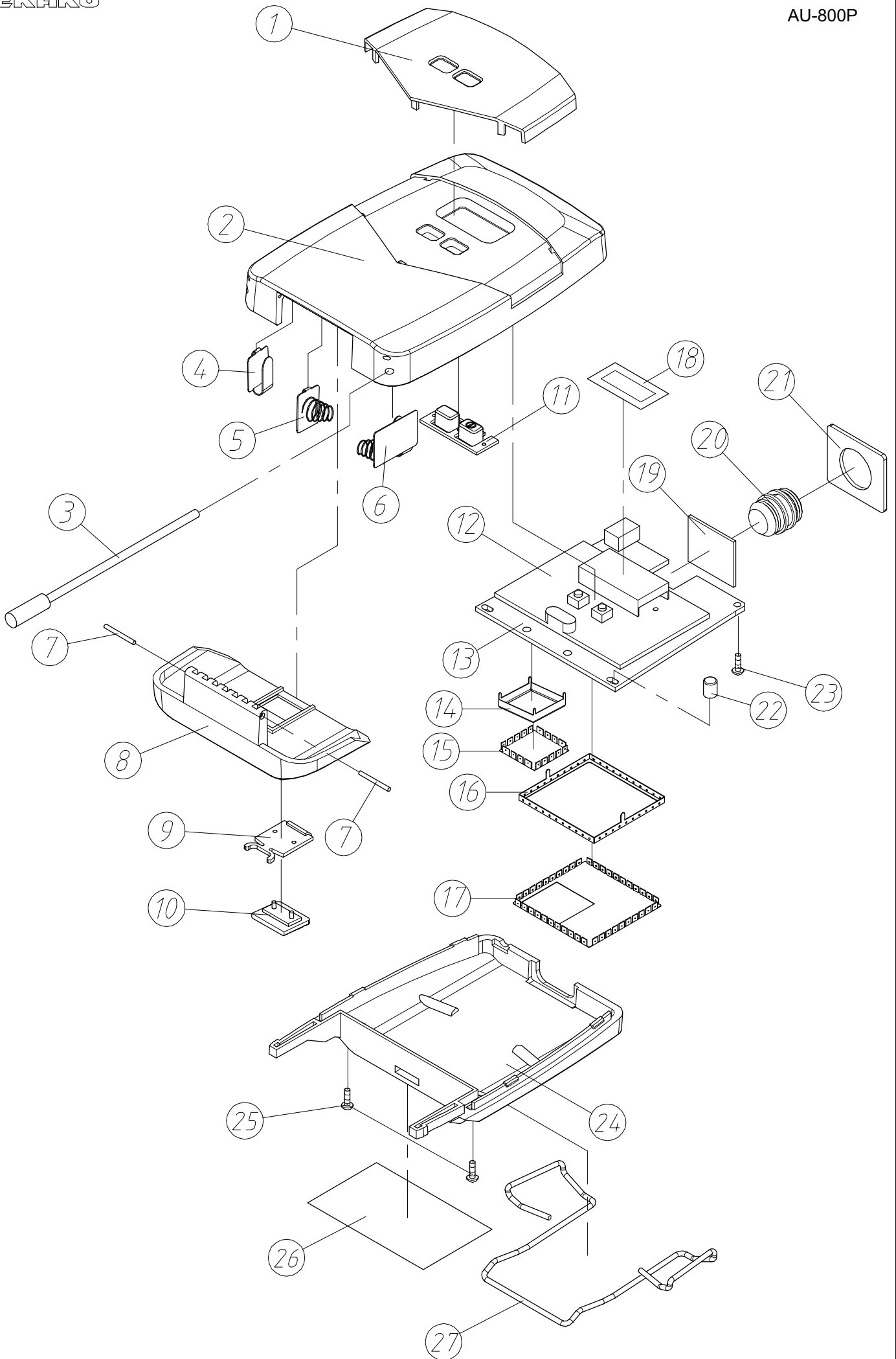

MECHANICAL PARTS LIST

AU-800R

No.	Part No.	Description	Specification	Pcs
1	MA05849	ZC-panel	AU-800R ALTO V1.0	1
2	HI00334	SW-RS	R612KKFT0F1	1
3	HA02028	K-TMP male + TNC female pin	UL1107 AWG25 L=210mm	2
4	NI04305	ZC-plastic panel-ABS	AU-800R ALTO V1.0	1
5	HK06962	K-PC board	P-AU-800R-LCD-DIP	1
6	NI03446	acrylic panel	UR-81DR 16*65*2.8 V1.1	1
7	NI04077	key-PP +5%	AU-800R 4.7*8.7*8.4 black V1.0	1
8	MG00521	screw	M3*7 V1.0	4
9	MB04682	ZC-chassis	AU-800R V1.0	1
10	HK06849	K-PC board	P-AU-800R F7-DIP	1
11	MI02600	ZD-barrier-UP-8DR-03	UP-8DR 26.5*30.5*11 V1.0	2
12	MI02601	ZD-barrier top cover-UP-8DR-04	UP81-DR 31.1*27.1*3.5 V1.1	2
13	MG00036	screw	M3*4	9
14	MG00061	screw-RS	M3*10	2
15	MC00792	ZD-top cover	AU-800R V1.0	1
16	MG00043	screw-RS	M4*6	4
17	NI00498	self-adhere foot cushion	12.7*7*6mm(SF-005)	4
18	HF00004	TNC main aerial TNC head	C431(794~806MHZ)	2

AU-800H

No.	Part No.	Description	Specification	Pcs
1	NI03471	ZB-plastic middle socket	UP-8H V1.0	1
2	NI04219	ZC-plastic panel	AU-800H ALTO-V1.0	1
3	NI03458	acrylic panel-RS	UP-8H 2.5*12*23-V1.0	1
4	NI03467	knob-ABS	UP-8H 25*12.8 black-V1.1	1
5	NI03764	cushion -RS-70°	UP-8H 5*21*27 black-V1.0	1
6	NI03452	battery bracket-ABS	UP-8Hφ32*170.5 black-V1.2	1
7	HK06960	K-PC board	P-UP-8H(V2)-F7-DIP (AU-800H)	1
8	NI03465	fixed board-ABS	UP-8H φ26*6 black-V1.0	1
9	MK00093	spring sheet-copper (C5191)	0.3t*1*4.09*12.99 UP-8H-V1.1	3
10	HA01837	wire-RS UL/CSA 1571#28 TS	φ0.9*43mm black	1
11	HA01847	wire-RS UL/CSA 1571#28 TS	φ0.9*43mm red	1
12	HG00176	buzzer	PB-09N23P-03	1
13	MK00084	spring piece-RS-battery point	UP-8H 0.3*15*20 positive V1.2	1
14	MK00099	spring piece-battery point	UP-8H 10*15*12 negative V1.0	1
15	MI03098	ZD-separating shade-UP8P-13	UP-8P 0.2t*2.8*14.2*14.3 V1.4	1
16	MI02867	ZD-separating shade-UP8P-26	UP-8H 0.2t*4.8*23.1*29.1 V1.4	2
17	MI02865	ZD-separating shade top cover-UP8H-24	UP-8H 0.2t*23.5*29.5*2.4 V1.3	1
18	MI02866	ZD-separating shade top cover-UP8H-25	UP-8H 0.2t*23.5*29.5*2.4 V1.2	1
19	NI03451	battery bracket-RS-C-ABS	UP-8H 13.4*113.5 black V1.0	1
20	MG00626	screw	M2*10 V1.0	1
21	NI03466	aerial tube-blue & purple 2665C	UP-8H φ20.6*48.8 V1.4	1
22	MG00022	screw	M2.3*6	2
23	NI04272	ZB-tail tube	AU-800H φ37*120 V1.0	1
24	HK05722	K-magnetic head	DM-38	1
25	MD00777	up-down steel net combination	AU-800H φ50*62 V1.0	1
26	HG00163	magnetic head	DM-38 300Ω±20%	1
27	NI03595	cushion-RS	UP-8H φ35.1*15(DM-38) black V	1
28	MH01978	magnetic head-aluminum	UP-8H φ38*36(DM-38) V1.0	1
29	HB01739	PC board-FR4/2L 29.2*29.2*1.2	UP-MIC VER050502	1
30	HA01781	wire-RS	70mm red (1571#32)φ0.6	1
31	HA01782	wire-RS	70mm black (1571#32)φ0.6	1
32	ND00593	wind-proof sponge-RS	φ38*φ43.1*33 UP-83H black V1.	1

AU-800P

No.	Part No.	Description	Specification	Pcs
1	NI04125	LCD cover-	MOD-16P 7*43*67.82 V1.0	1
2	NI04304	ZC-top cover-ABS	AU-800P ALTO V1.0	1
3	HF00052	aerial-RS	YH940805 φ4*82.4mm	2
4	MK00114	leaf spring- battery point	UP-8P 0.3t*17*12*1.6 正 V1.0	1
5	MK00113	leaf spring- battery point	UP-8P 17*12*10 negative V1.0	1
6	MK00112	leaf spring- battery point	UP-8P 25.5*10.5*10*1.6 ± V1.0	1
7	MH01488	bolt-RS-	φ1.0*10mm SAMSON-T-V1.1	2
8	NI04193	ZB-battery cover	UP-8P 20.7*32.5*68.5 V1.1	1
9	NI03587	battery cover switch-PP+	UP-8P 2*12*19 black V1.0	1
10	NI04198	ZB-battery cover switch-	UP-8P 4.5*10.7*14.5 V1.0	1
11	NI04126	push button-ABS	MOD-16P 5.4*9*24 black V1.0	1
12	HK07070	K-PC board	P-UP-8P-A-DIP(AU-800P)	1
13	HK05770	K-PC board	P-UP-8P-B F7-DIP	1
14	MI03098	ZD-seperating shade-UP8P-13	UP-8P 0.2t*2.8*14.2*14.3 V1.4	1
15	MI03096	ZD-seperating shade-UP8P-12	UP-8P 0.2t*2.8*14.2*14.3 V1.4	1
16	MI03458	ZD-seperating shade-UP8P-16	UP-8P 0.2t*5*30*31.8 V1.0	1
17	MI03457	ZD-seperating shade top cover-UP8P-15	UP-8P 0.2t*2*30*31.8 V1.0	1
18	NI04232	anti-dazzling screen	UP-8P 14.6*27.8*0.3t V1.0	1
19	HB01944	PC board-RS-FR4/2L?11.5*12*1.2	UP-8P-BAL VER051116	1
20	HC00801	mini balanced MIC socket	TQ-4MC	1
21	NI04194	ZB-fixed piece	UP-8P 1*16.9*19.5 V1.0	1
22	MG0069	copper pillar	φ3.7*φ4.7*4.8 V1.0	1
23	MG0041	screw -RS	M2*6 B	1
24	NI04191	ZB-bottom cover	UP-8P 12*69*91.1 V1.0	1
25	MG0062	screw -RS	M2*10 V1.0	2
26	NE15894	ZC-39.5*23.5mm	AU-800P(F7 798-827)ALTO V1.0	1
27	MK00105	ZE-spring clip-black	UP-8P φ1.5*11*48.2*68.5mm V1.0	1

9. BOM

AU-800R

No.	Part No.	Description	Specification	Remark
1	MA05849	panel	AU 800R ALTO V1.0	
2	MA05726	panel	AU 800R	
3	AE00055	solvent	solvent	
4	AE00056	paint RS	2745	
5	MA05725	panel	AU 800R 2.1*14.6*44*210 V1.0	
6	MI01281	panel	2.1*44*14.6*210 V1.1	
7	NI03446	acrylic panel	UR 81DR 16*65*2.8 V1.1	
8	NI04077	key	AU 800R 4.7*8.7*8.4 black V1.0	
9	MB04682	chassis	AU 800R V1.1	
10	MB04533	chassis	AU 800R	
11	AE00055	solvent	solvent	
12	AE00056	paint RS	2745	
13	MB04532	chassis	AU 800R 11*38.8*151*207 V1.0	
14	ME00035	iron pillar	hexagon6.35*M3*6	
15	MJ00058	single light board	1*2135*1220 20.45kg	
16	MC00792	top cover	AU 800R V1.0	
17	AE00055	solvent	solvent	
18	AE00056	paint RS	2745	
19	MC00791	top cover	AU 800R 210*152*39.8 V1.0	
20	MJ00058	single light board	1*2135*1220 20.45kg	
21	NI00498	self adhere foot cushion	12.7*7*6mm(SF 005)	
22	HF00004	aerial	C431(794~806MHZ)	
23	HI00334	power switch RS	R612KKFT0F1	
24	NI00252	sleeve	φ4*20mm	
25	NI00248	sleeve	φ4*1000mm	
26	HA01422	wire RS	2P 150mm UL1007 22AWG	
27	HA03734	wire	10P 200mm UL20798 PH:1.25mm white	
28	MI02601	separating shade top cover RS	UP81 DR 31.1*27.1*3.5 V1.1	
29	MJ01185	tinplate	0.33*700*910mm 1.6kg V1.1	
30	HC00034	short circuit connector	NO.2700 2.54mm/6mm OPEN	
31	MG00521	screw	M3*7 V1.0	
32	MG00061	screw RS	M3*10	
33	MG00036	screw	M3*4	
34	MG00043	screw	M4*6	
35	NE15732	lable	AU 800R(F7 798 827) ALTO V1.0	
36	NI00019	membrane	0.065*1M	
37	NH00245	label	0.07*1M	
38	NE15734	lable	AU 800R ALTO V1.0	
39	NI00014	membrane	0.035*1M	
40	NH00012	bond paper	0.04*1M	
41	NB04605	gift carton RS	Wireless Mic. System ALTO V1.1	
42	NE15836	lable	AU 800 SERIES ALTO V1.0	
43	NE15839	lable	AU 800 SERIES ALTO V1.0	
44	NI00021	membrane	0.075*1M	
45	NH00016	bond paper	0.08*1M	
46	NE14484	label	F7 (798 827 MHz) SHOW V1.0	
47	NI00014	membrane	0.035*1M	
48	NI00035	adhesive label	0.04*1m	
49	NE12052	label RS ACT	PE	
50	NH00334	cone paper	0.040*1m	
51	NB02688	box	ATW T161;162	
52	NB02690	box	ATW R160	
53	NB04028	inner case	UP 8DR V1.0	
54	NB04030	carton	UP 8DR V1.0	
55	NA00173	air bladder bag	315*90mm	
56	NA00171	air bladder bag	335*287mm	

No.	Part No.	Description	Specification	Remark
57	HJ00006	dessicant	30g	
58	NB02691	box	ATW R160 ADAPTOR	
59	NB04031	inner case	UP 8DR/8H/88H V1.0	
60	NB04032	cardboard	63*70mm UP 8DR/8H V1.0	
61	NB04033	cardboard	4hole 1002*57mm UP 8DR V1.0	
62	NB04034	cardboard	454*120mm UP 8P V1.0	
63	NB04035	cardboard	164*60mm UP 8H/88H V1.0	
64	HA01871	signal wiring RS	φ6.3*φ5*φ6.3*5FT	
65	TG00015	adaptor RS	230V/50Hz 15V/500mA EI 41 CE	
66	NF00061	assurance card	ALTO	
67	HK06962	PC board	P AU 800R LCD DIP	
68	HH00063	back light RS	DB74250508 74*25*5.18mm	
69	HC00739	connector(female)	10P 1.25mm 180°	CN1
70	HE00034	LCD module	DTA102956ALP	LCD
71	SA00291	L.E.D RS	KA 1114/2QBC C CC L5	LED
72	HI00041	push button switch	6*6*5	S1,S2,S3,S4
73	NI01775	LED spacer support	LEDS 2.5 2.5mm	
74	AC00179	tin without lead RS	M705E Sn 3Ag 0.5Cu	
75	HK06850	PC board	P AU 800R LCD SMD	
76	HB01926	PCB RS	AU 800R LCD VER060905	
77	RD00065	SMD fixed resistor 1/10W	47Ω ±5% 0603	R1,R2
78	SG00206	SMD integrated circuit	HT1621(SSOP48)/(HOLTEK)	U1
79	HK06849	PC board	P AU 800R F7 DIP	
80	CB00021	electrolytic capacitor	10uF/16V φ4*5mm	C47,C235
81	SC00398	crystal oscillator	12.000MHZ	X1
82	SC00004	crystal oscillator	16.00MHZ	X54
83	CB00317	electrolytic capacitor	22uF/63V φ5*11mm (NICHICON)	C122,C123,C135
84	SC00406	crystal oscillator	41.050MHz	X2
85	CB00065	electrolytic capacitor	470uF/25V φ10*16mm	C132,C134
86	CB00037	electrolytic capacitor	47uF/16V φ6*5mm	C168,C171
87	CG00013	ceramic filter	CDALA10M7G016 B0	IFT7
88	HC00111	balance MIC jack	99M 108SP1	CN60
89	HC00738	connector(female)	10P 1.25mm 90°	CN56
90	HC00151	connector	2.0 180° 5P(gold plated) 3.8/8.5mm	J54
91	HC00065	connector(male)	2P 2.5mm 90°	CN55
92	HC00077	connector(male)	3P 2.5mm 180°	CN5
93	HC00183	DC jack RS	KJ 36 S φ3.5	DCJK
94	RG00019	over current protector	0.4A/60V PFR60V040	F56
95	SD00075	integrated circuit	L7810CV(TO220)/(ST)	IC3
96	HC00098	MIC jack RS	JY 6313 01 020	CN59
97	CG00069	ceramic filter	SFELF10M7JAA0 B0 150kHz±40kHz	IFT1,IFT2,IFT3
98	NI01906	cushion	QW 3(HC 49U)	
99	ND00108	EV foam	7*3*2	
100	HK06653	PC board	P UP 8DR(V2) F7 SMD	
101	HB02046	PCB RS	UP 8DR RX V2 VER060121	
102	CI00031	SMD ceramic capacitor 0805	2.2uF/16V Y5V 0805(2012)	C53,C129,C144,C159,C216,C222,C245
103	CI00047	SMD ceramic capacitor 0603	10PF/50V C0G±0.25PF(C1608C0G1H100CT)/TDK	C176
104	CI00049	SMD ceramic capacitor 0603	15PF/50V C0G±5%(C1608C0G1H150JT)/TDK	C49,C55,C105
105	CI00051	SMD ceramic capacitor 0603	22PF/50V C0G±5%(C1608C0G1H220JT)/TDK	C2,C119,C120,C154,C156,C174,C183,C241,C246
106	CI00053	SMD ceramic capacitor 0603	33PF/50V C0G±5%(C1608C0G1H330JT)/TDK	C1,C190,C201
107	CI00055	SMD ceramic capacitor 0603	47PF/50V C0G±5%(C1608C0G1H470JT)/TDK	C3,C4,C5,C15,C45,C46,C50,C57,C58,C59,C73,C86,C107,C121,C140,C141,C199,C202,C206,C208,C209,C221
108	CI00056	SMD ceramic capacitor 0603	56PF/50V NPO ±5%	C23,C25,C33,C78,C80,C172
109	CI00061	SMD ceramic capacitor 0603	220PF/50V NPO ±5%	C160

No.	Part No.	Description	Specification	Remark
110	CI00063	SMD ceramic capacitor 0603	470PF/50V NPO ±5%	C64,C65,C67,C68,C89,C138,C139,C231
111	CI00066	SMD ceramic capacitor 0603	0.0018uF/50V X7R ±10%	C52
112	CI00067	SMD ceramic capacitor 0603	0.0022uF/50V X7R ±10%	C106
113	CI00071	SMD ceramic capacitor 0603	0.01uF/50V X7R ±10%	C14,C56,C95,C127,C175,C181,C204,C217,C218,C243
114	CI00072	SMD ceramic capacitor 0603	0.022uF/50V X7R ±10%	C31,C185
115	CI00076	SMD ceramic capacitor 0603	1PF/50V C0G±0.25PF(C1608C0G1H010CT)/TDK	C29
116	CI00079	SMD ceramic capacitor 0603	1.8PF/50VC0G±0.25PF(C1608C0G1H1R8CT)TDK	C8
117	CI00082	SMD ceramic capacitor 0603	3.3PF/50VC0G±0.25PF(C1608C0G1H3R3CT)TDK	C32
118	CI00084	SMD ceramic capacitor 0603	4.7PF/50VC0G±0.25PF(C1608C0G1H4R7CT)TDK	C225,C232
119	CI00085	SMD ceramic capacitor 0603	5.6PF/50VC0G±0.25PF(C1608C0G1H5R6CT)TDK	C21
120	CI00086	SMD ceramic capacitor 0603	6PF/50V C0G±0.25PF(C1608C0G1H060CT)/TDK	C242,C207
121	CI00089	SMD ceramic capacitor 0603	0.5PF/50VC0G±0.25PF(C1608C0G1H0R5CT)TDK	C167,C240
122	CI00090	SMD ceramic capacitor 0603	0.0047uF/50V X7R ±10%	C19,C36
123	CI00131	SMD ceramic capacitor 0603	3.5PF/50VC0G±0.25PF(C1608C0G1H3R5CT)TDK	C210
124	CI00132	SMD ceramic capacitor 0603	2PF/50V C0G±0.25PF(C1608C0G1H020CT)/TDK	C20,C34,C37,C40,C108,C239
125	CI00143	SMD ceramic capacitor 0603	200PF/50V C0G±5%(C1608C0G1H201JT)/TDK	C166
126	CI00164	SMD ceramic capacitor 0603	0.47PF/50V ±0.25PF(C1608C0G1HR47CT)/TDK	C196
127	CI00175	SMD ceramic capacitor 0603	1.0uF/16V X7R±10%(C1608X7R1C105KT)/TDK	C61,C101,C115,C192,C143
128	CI00176	SMD ceramic capacitor 1206	10uF/10V Y5V +80; 20%	C117,C126,C136,C137,C149,C164,C184
129	CI00177	SMD ceramic capacitor 1206	22uF/10V Y5V +80; 20%	C17
130	CI00179	SMD ceramic capacitor 0603	0.22uF/25V X7R±10%(C1608X7R1E224KT)/TDK	C11,C158
131	CI00180	SMD ceramic capacitor RS ACT	10uF/10V Y5V +80; 20%	C26,C223,C146
132	CI00185	SMD ceramic capacitor 0603	0.1uF/50V X7R±10%(C1608X7R1H104KT)/TDK	C7,C10,C12,C13,C24,C27,C28,C44,C75,C76,C77,C79,C81,C82,C83,C84,C90,C91,C102,C111,C112,C113,C114,C128,C133,C148,C151,C169,C170,C186,C193,C205,C236
133	CI00188	SMD ceramic capacitor 0603	3PF/50V C0G±0.25PF(C1608C0G1H030CT)/TDK	C18,C43,238
134	CI00190	SMD ceramic capacitor 0603	5PF/50V C0G±0.25PF(C1608C0G1H050CT)/TDK	C41
135	CI00193	SMD ceramic capacitor 0603	8PF/50V C0G±0.25PF(C1608C0G1H080CT)/TDK	C16
136	CI00196	SMD ceramic capacitor RS	4.7uF/16V Y5V +80; 20%	C178,C118
137	CI00200	SMD ceramic capacitor 0603	0.0068uF/50V ±10%(C1608X7R1H682KT)/TDK	C150
138	CI00206	SMD ceramic capacitor 0603	0.047uF/50V ±10%(C1608X7R1H473KT)/TDK	C131
139	CI00215	SMD ceramic capacitor 0603	68PF/50V C0G ±5%(C1608C0G1H680JT)/TDK	C162
140	CI00216	SMD ceramic capacitor 0603	82PF/50V C0G ±5%(C1608C0G1H820JT)/TDK	C173
141	CI00217	SMD ceramic capacitor 0603	100PF/50V C0G ±5%(C1608C0G1H101JT)/TDK	C63,C155,C165,C188,C226,C109
142	CI00226	SMD ceramic capacitor 0603	680PF/50V C0G ±5%(C1608C0G1H681JT)/TDK	C54,C71,C92,C93,C94,C110,C163
143	CI00228	SMD ceramic capacitor 0603	0.001uF/50V C0G±5%(C1608C0G1H102JT)/TDK	C6,C9,C30,C42,C62,C66,C69,C70,C72,C74,C98,C99,C100,C103,C104,C130,C145,C147,C157,C182,C191,C195,C219,C227,C228,C229,C230
144	CI00233	SMD ceramic capacitor 0603	0.0027uF/50VC0G±5%(C1608C0G1H272JT)/TDK	C152
145	CI00234	SMD ceramic capacitor 0603	0.0033uF/50VC0G±5%(C1608C0G1H332JT)/TDK	C187
146	CK00004	SMD adjustment capacitor	V10P TZV02Z100A110	VC3
147	CK00005	SMD adjustment capacitor	V6P TZVY2Z060A110	VC2
148	CK00010	SMD half adjustment capacitor	4.5 20PF N750 TZY2R200A001R00	VC1
149	CL00001	SMD tantalum capacitor RS ACT	0.47uF/25V case A	C85
150	CL00002	SMD tantalum capacitor RS ACT	1.0uF/16V case A	C220
151	CL00004	SMD tantalum capacitor RS ACT	4.7uF/20V case A(ELNA)	C189
152	CL00007	SMD tantalum capacitor RS ACT	10uF/10V case A	C22,C35,C38,C39,C60,C116,C124,C125,C142,C179,C197,C198,C203,C233,C234
153	CL00008	SMD tantalum capacitor	47uF/7V case B2	C194,C224
154	CM00052	SMD filter 2POLE 6mm	20M DFC808B20A	T4,T6
155	CM00054	SMD ceramic filter	MKFKB51M7JA0P00B0S/(Murata)	IF1
156	CO00043	SMD chip inductance 0603	68nH±5%(LQG11A68NJ00T1)/(MURATA)	L59,L60
157	CO00051	SMD chip inductance	1uH (NLV25T 1R0J)/(TDK)	L68,L69,L70
158	CO00069	SMD chip inductance RS	15nH±5%(MLG1608B15NJ)/(TDK)	L3,L4,L8,L11,L78,L22,C180

No.	Part No.	Description	Specification	Remark
159	CO00071	SMD chip inductance RS	47nH±5%(MLG1608B47NJT)/(TDK)	L9
160	CO00076	SMD chip inductance RS	18nH±5%(MLG1608B18NJT)/(TDK)	L12,L20
161	CO00088	SMD chip inductance RS	1.0uH±10%(MLF1608A1R0K)/(TDK)	L17,L18
162	CO00090	SMD chip inductance RS ACT	1.0uH±10%(MLI 321611 1R0K)/(MALA)	L5
163	CO00094	SMD inductance	6.8nH±0.2nH(LQW18AN6N8C00D)/(MURATA)	L2
164	CO00096	SMD inductance RS	60Ω±25%(MLB 201209 0060A N2)/(MALA)	T1,T2,T7,T8,T9
165	CO00097	SMD inductance RS	80Ω±25%(MLB 160808 0080A N2)/(MALA)	T11
166	CO00110	SMD chip inductance	4.7uH±5%(MLF1608A4R7J)/(TDK)	L10,L24,L25
167	CO00118	SMD chip inductance RS	100nH±5%(MLG1608BR10JT)/(TDK)	L14,L16
168	CO00119	SMD chip inductance 0603	150nH±5%(MLG1608SR15JT)/(TDK)	L19
169	CO00124	SMD chip inductance RS 0603	180nH±5%(MLG1608SR18JT)/(TDK)	L21
170	RD00059	SMD fixed resistor 1/10W	0.0Ω ±5% 0603	R9,R25,R77,R119,R121,L7,R34
171	RD00061	SMD fixed resistor 1/10W	10Ω ±5% 0603	R13,R15,R153
172	RD00062	SMD fixed resistor 1/10W	18Ω ±5% 0603	R10,R14,R47
173	RD00065	SMD fixed resistor 1/10W	47Ω ±5% 0603	R24,R154
174	RD00068	SMD fixed resistor 1/10W	100Ω ±5% 0603	R23,R62,R70,R156
175	RD00076	SMD fixed resistor 1/10W	330Ω ±5% 0603	R108
176	RD00078	SMD fixed resistor 1/10W	470Ω ±5% 0603	R21,R163
177	RD00080	SMD fixed resistor 1/10W	680Ω ±5% 0603	R166
178	RD00083	SMD fixed resistor 1/10W	1.0KΩ ±5% 0603	R2,R6,R16,R17,R18,R27,R50,R54,R56,R64,R66 ,R69,R95,R96,R98,R136,R145,R184,R7
179	RD00084	SMD fixed resistor 1/10W	1.2KΩ ±5% 0603	R42,R123,R161
180	RD00085	SMD fixed resistor 1/10W	1.5KΩ ±5% 0603	R118,R120,R133
181	RD00087	SMD fixed resistor 1/10W	2.0KΩ ±5% 0603	R28,R165,R75
182	RD00088	SMD fixed resistor 1/10W	2.2KΩ ±5% 0603	R41,R51,R105,R182,R183
183	RD00090	SMD fixed resistor 1/10W	3.0KΩ ±5% 0603	R71
184	RD00091	SMD fixed resistor 1/10W	3.3KΩ ±5% 0603	R99,R142,R72
185	RD00093	SMD fixed resistor 1/10W	4.7KΩ ±5% 0603	R152,R3,R4,R5,R35,R39,R40,R48,R60,R61,R68 ,R81,R82,R83,R102,R103,R115,R168
186	RD00095	SMD fixed resistor 1/10W	5.6KΩ ±5% 0603	R43,R130,R132
187	RD00097	SMD fixed resistor 1/10W	6.8KΩ ±5% 0603	R55
188	RD00098	SMD fixed resistor 1/10W	7.5KΩ ±5% 0603	R167
189	RD00099	SMD fixed resistor 1/10W	8.2KΩ ±5% 0603	R12
190	RD00101	SMD fixed resistor 1/10W	10KΩ ±5% 0603	R11,R19,R44,R45,R59,R63,R65,R73,R86,R87,R 88,R89,R90,R91,R93,R94,R104,R110,R113,R12 7,R131,R134,R135,R144,R149,R150,R151,R157 ,R176,R129,R106
191	RD00103	SMD fixed resistor 1/10W	15KΩ ±5% 0603	R79,R100,R138
192	RD00105	SMD fixed resistor 1/10W	22KΩ ±5% 0603	R8,R76,R85,R111,R112,R114,R116,R117,R128, R139,R159
193	RD00106	SMD fixed resistor 1/10W	27KΩ ±5% 0603	R58,R101
194	RD00108	SMD fixed resistor 1/10W	33KΩ ±5% 0603	R80,R84,R148
195	RD00111	SMD fixed resistor 1/10W	47KΩ ±5% 0603	R38,R126,R164,R169
196	RD00112	SMD fixed resistor 1/10W	56KΩ ±5% 0603	R124,R26
197	RD00113	SMD fixed resistor 1/10W	62KΩ ±5% 0603	R162
198	RD00116	SMD fixed resistor 1/10W	100KΩ ±5% 0603	R20,R30,R33,R57,R67,R160
199	RD00117	SMD fixed resistor 1/10W	120KΩ ±5% 0603	R107
200	RD00118	SMD fixed resistor 1/10W	150KΩ ±5% 0603	R49,R78,R109
201	RD00119	SMD fixed resistor 1/10W	220KΩ ±5% 0603	R122,R53
202	RD00123	SMD fixed resistor 1/10W	470KΩ ±5% 0603	R31
203	RD00306	SMD fixed resistor 1/10W	20KΩ ±5% 0603	R92
204	RD00074	SMD fixed resistor 1/10W	270Ω ±5% 0603	R1
205	RF00002	SMD semi fixed resistor	EVN5ES X50B24 20K	VR1
206	RF00003	SMD semi fixed resistor	EVN5ES X50B53 5K	VR2,VR3,VR5
207	SE00053	SMD rectifier diode RS ACT	SM4002	D56,D61
208	SE00058	diode	BAP50 03/(PHI)	D1,D4

No.	Part No.	Description	Specification	Remark
209	SE00059	SMD varactor	BB142/(PHI)	VD1
210	SE00060	SMD rectifier diode	DA204UT106/(ROHM)	D60
211	SE00061	SMD rectifier diode	1SS355 TE17/(ROHM)	D57,D62
212	SE00070	SMD Schottky barrier diode RS	0.7A/400V S07G	D6
213	SF00010	SMD transistor RS ACT	2SC2412K(SC59)/(ROHM)	Q3,Q5,Q7,Q8,Q11,Q12,Q13,Q17,Q21,Q24
214	SF00020	voltage stabilized transistor	3.0V XC62FP3002MR(SOT23)/(TOREX)	IC2
215	SF00067	transistor	BFG425W/(PHI)	Q1,Q2
216	SF00068	transistor	2SK2731 T146/(ROHM)	Q4
217	SF00069	transistor	RTR030P02 TL(TSMT3)/(ROHM)	Q6
218	SF00071	voltage stabilized transistor	5.0V XC6203E502PR(SOT89)/(TOREX)	IC4
219	SF00078	transistor	DTC614TU(UMT3)/(ROHM)	Q9,Q10,Q16,Q18,Q19,Q22
220	SF00090	SMD transistor RS	BF1105R(SOT 143R)/(PHI)	Q14,Q15
221	SG00003	SMD integrated circuit	BA15218F(SOP8)/(ROHM)	IC10
222	SG00004	SMD integrated circuit	BA1604F(SOP8)/(ROHM)	IC6
223	SG00007	SMD integrated circuit	MB15E03SLPFV ER(SOP16)/(FUJITSU)	IC1
224	SG00034	SMD integrated circuit	TA31161FN(EL)	IC5
225	SG00040	SMD integrated circuit	MC33078DT/MC33078D(SO8)/(ST/MOTOROLA)	IC11
226	SG00070	SMD integrated circuit	74HC393DT(SO14)/(PHI)	IC17
227	SG00558	integrated circuit RS	UTC4580M(4580M)(SOP8)/(YW)	IC7,IC8,IC12
228	SG00207	SMD integrated circuit	24LC00T/OT(SOT23)/(MICROCHIP)	IC16
229	SG00315	integrated circuit	PIC16F74 I/PT(TQFP44)/(MICROCHIP)	IC14
230	SG00373	SMD integrated circuit	SA575DTBR2(TSSOP20)/(ON)	IC15
231	MI02600	separating shade RS ACT	UP 8DR 26.5*30.5*11 V1.1	
232	MJ01185	tinplate	0.33*700*910mm 1.6kg V1.1	
233	AE00449	solder material without lead	9308/Sn Ag Cu	
234	CI00219	SMD ceramic capacitor 0603	150PF/50V C0G ±5%(C1608C0G1H151JT)/TDK	C51
235	CI00189	SMD ceramic capacitor 0603	4PF/50V C0G±0.25PF(C1608C0G1H040CT)/TDK	C244
236	CO00067	SMD chip inductance RS	10nH±5%(MLG1608B10NJT)/(TDK)	L1,L15
237	CI00081	SMD ceramic capacitor 0603	2.7PF/50VC0G±0.25PF(C1608C0G1H2R7CT)TDK	C97
238	RF00001	SMD semi fixed resistor	EVN5ES X50B54 50K	VR4
239	MG00037	screw	M3*4	
240	AC00179	tin without lead RS	M705E Sn 3Ag 0.5Cu	
241	NI04291	plastic panel	AU 800R V1.0	
242	NI04076	panel RS	AU 800R 12.8*36*119.8 V1.0	
243	NF02566	user manual English RS ACT	AU 800R 800P 800H ALTO V1.2	
244	NH00149	paper	889*640mm	
245	HA04736	single terminal wiring tnc(mal	210mm UL 1107 25AWG black	
246	HA04737	single terminal wiring RS C	210mm UL1107 25AWG black	
247	HC00370	TNC jack	WJ 7417 RG174	

AU-800H

No.	Part No.	Description	Specification	Remark
1	NI04219	plastic panel	AU 800H ALTO V1.0	
2	NI03473	panel	UP 8H V1.0	
3	NI03450	panel RS	UP 8H 34.68*50*21 black V1.1	
4	AE00385	paint RS	PU2001	
5	AE00384	paint RS	PU2001	
6	AE00383	paint RS	PU2001	
7	AE00382	paint RS	PU1900	
8	AE00381	paint RS	PU1900	
9	AE00380	paint RS	PU1900	
10	NI03471	middle socket	UP 8H V1.0	
11	NI03470	middle socket RS	UP 8H 38 φ40*56.5 black V1.2	
12	AE00385	paint RS	PU2001	
13	AE00384	paint RS	PU2001	
14	AE00383	paint RS	PU2001	
15	AE00382	paint RS	PU1900	
16	AE00381	paint RS	PU1900	
17	AE00380	paint RS	PU1900	
18	MG00022	screw	M2.3*6	
19	NI03458	acrylic panel RS	UP 8H 2.5*12*23 V1.1	
20	NI03467	knob RS	UP 8H 25*12.8 black V1.2	
21	NI03764	caushion RS	UP 8H 4*21*27 black V1.1	
22	NI03452	battery bracket RS	UP 8H φ32*170.5 black V1.2	
23	NI03465	fixed board RS	UP 8H φ26*6 black V1.1	
24	MK00093	battery spring piece RS	0.3t*1*4.09*12.99 UP 8H V1.2	
25	MK00084	spring piece	UP 8H 0.3*15*20 V1.3	
26	NI03451	battery bracket RS	UP 8H 13.4*113.5 black V1.1	
27	NI03466	tube RS	UP 8H φ20.6*48.8 V2.0	
28	NI04272	tail tube	AU 800H φ37*120 V1.0	
29	AE00385	paint RS	PU2001	
30	AE00382	paint RS	PU1900	
31	AE00383	paint RS	PU2001	
32	AE00380	paint RS	PU1900	
33	AE00384	paint RS	PU2001	
34	AE00381	paint RS	PU1900	
35	NI04078	tail tube	AU 800H φ37*120 black V1.0	
36	MD00777	up down steel net combination	AU 800H φ50*62 V1.0	
37	HG00176	buzzer	PB 09N23P 03	
38	HA01837	wire RS	43mm black L3R3	
39	HA01847	wire RS	37mm red L3R3	
40	HK05722	magnetic head	DM 38	
41	MH01978	MIC socket	UP 8H φ38*36(DM 38) V1.0	
42	HA01781	wire RS	70mm L2R2	
43	HA01782	wire RS	70mm L2R2	
44	NI03595	caushion	UP 8H φ35.1*15(DM 38) black V1.1	
45	HG00163	megnatic head	DM 38 300Ω±20%	
46	HB01739	PCB	UP MIC VER050502	
47	ND00593	wind proof sponge RS	φ40.7*φ43.1*33 UP 83H black V1.2	
48	NI03851	rubber coil RS	φ50.5*7 black V1.1	
49	MK00099	spring piece RS	UP 8H 10*15*12 V1.1	
50	MG00626	screw RS	M2*10 V1.1	
51	NE15899	lable	AU 800H ALTO V1.0	
52	NI00014	membrane	0.035*1M	
53	NH00012	bond paper	0.04*1M	
54	NE15900	lable	AU 800H(F7 798 827)ALTO V1.0	
55	NI00019	membrane	0.065*1M	
56	NH00245	label	0.07*1M	

No.	Part No.	Description	Specification	Remark
57	NI03833	tube RS C	UP 8H φ20.6*48.8 V2.0	
58	NI03832	tube RS C	UP 8H φ20.6*48.8 V2.0	
59	NI03829	tube RS C	UP 8H φ20.6*48.8 V2.0	
60	NI03828	tube RS C	UP 8H φ20.6*48.8 V2.0	
61	NI03827	tube RS C	UP 8H φ20.6*48.8 V2.0	
62	NI03826	tube RS C	UP 8H φ20.6*48.8 V2.0	
63	NE12052	label RS ACT	PE	
64	NH00334	cone paper	0.040*1m	
65	MI02866	separating shade top cover RS	UP 8H 0.2t*23.5*29.5*2.4 V1.2	
66	MJ01314	tinplate	0.2t*40*1M(1M/0.5KG) V 1.0	
67	MI02865	separating shade top cover RS	UP 8H 0.2t*23.5*29.5*2.4 V1.3	
68	MJ01314	tinplate	0.2t*40*1M(1M/0.5KG) V 1.0	
69	HK06960	PC board	P UP 8H(V2) F7 DIP(AU 800H)	
70	SC00398	crystal oscillator	12.000MHZ	X1
71	SC00004	crystal oscillator	16.00MHZ	X130
72	HC00148	connector	2.0 180° 3P(gold plated) 3.8/8.5mm	CN8,CN9
73	HC00714	DC jack	LD 0211 1.3	CN5
74	HE00070	LCD module	DTE103067BEP	U130
75	HH00055	back light	50*25.5*3.0mm DB5025503CY	
76	NI01906	cushion	QW 3(HC 49U)	
77	AC00179	tin without lead RS	M705E Sn 3Ag 0.5Cu	
78	HK06961	PC board	P UP 8H(V2) F7 SMD(AU 800H)	
79	HB02047	PCB RS	UP 8H V2 VER061018	
80	CI00031	SMD ceramic capacitor 0805	2.2uF/16V Y5V 0805(2012)	C44,C55,C88,C97,C102,C111,C127
81	CI00047	SMD ceramic capacitor 0603	10PF/50V C0G±0.25PF(C1608C0G1H100CT)/TDK	C2,C42,C76
82	CI00049	SMD ceramic capacitor 0603	15PF/50V C0G±5%(C1608C0G1H150JT)/TDK	C67,C120,C138
83	CI00051	SMD ceramic capacitor 0603	22PF/50V C0G±5%(C1608C0G1H220JT)/TDK	C134,C135
84	CI00055	SMD ceramic capacitor 0603	47PF/50V C0G±5%(C1608C0G1H470JT)/TDK	C1,C3,C4,C5,C18,C24,C106,C113,C148,C155,C157
85	CI00062	SMD ceramic capacitor 0603	330PF/50V NPO ±5%	C147
86	CI00063	SMD ceramic capacitor 0603	470PF/50V NPO ±5%	C45,C78,C110,C112,C107,C108
87	CI00065	SMD ceramic capacitor 0603	0.001uF/50V X7R ±10%	C6,C58,C60,C61,C62,C63,C87,C114,C116,C146,C152
88	CI00071	SMD ceramic capacitor 0603	0.01uF/50V X7R ±10%	C10,C15,C54,C96,C124
89	CI00075	SMD ceramic capacitor 0603	0.1uF/50V Y5V +80, 20%	C7,C12,C27,C28,C46,C48,C50,C51,C53,C64,C89,C103,C104,C115,C117,C122,C125,C131,C132,C133,C136,C137,C141,C142,C145,C149
90	CI00076	SMD ceramic capacitor 0603	1PF/50V C0G±0.25PF(C1608C0G1H010CT)/TDK	C29,C37,C56,C81,C82,C84,C153
91	CI00079	SMD ceramic capacitor 0603	1.8PF/50VC0G±0.25PF(C1608C0G1H1R8CT)/TDK	C8,C20
92	CI00080	SMD ceramic capacitor 0603	2.2PF/50VC0G±0.25PF(C1608C0G1H2R2CT)/TDK	C73
93	CI00082	SMD ceramic capacitor 0603	3.3PF/50VC0G±0.25PF(C1608C0G1H3R3CT)/TDK	C23,C72,C74,C83
94	CI00084	SMD ceramic capacitor 0603	4.7PF/50VC0G±0.25PF(C1608C0G1H4R7CT)/TDK	C16,C14,C21,C75,C77
95	CI00089	SMD ceramic capacitor 0603	0.5PF/50VC0G±0.25PF(C1608C0G1H0R5CT)/TDK	C100
96	CI00090	SMD ceramic capacitor 0603	0.0047uF/50V X7R ±10%	C19,C25,C30,C32,C36,C43,C52,C158,C109
97	CI00131	SMD ceramic capacitor 0603	3.5PF/50VC0G±0.25PF(C1608C0G1H3R5CT)/TDK	C13,C26,C47
98	CI00132	SMD ceramic capacitor 0603	2PF/50V C0G±0.25PF(C1608C0G1H020CT)/TDK	C34,C40
99	CI00175	SMD ceramic capacitor 0603	1.0uF/16V X7R±10%(C1608X7R1C105KT)/TDK	C86,C130,C150
100	CI00176	SMD ceramic capacitor 1206	10uF/10V Y5V +80; 20%	C22,C38,C39,C85,C91
101	CI00177	SMD ceramic capacitor 1206	22uF/10V Y5V +80; 20%	C17,C95,C98,C118,C121,C123,C129
102	CI00179	SMD ceramic capacitor 0603	0.22uF/25V X7R±10%(C1608X7R1E224KT)/TDK	C11
103	CI00180	SMD ceramic capacitor RS ACT	10uF/10V Y5V +80; 20%	C49,C93
104	CI00188	SMD ceramic capacitor 0603	3PF/50V C0G±0.25PF(C1608C0G1H030CT)/TDK	C79
105	CI00214	SMD ceramic capacitor 0603	56PF/50V C0G ±5%(C1608C0G1H560JT)/TDK	C9,C33,C35,C41,C57,C65,C70
106	CI00217	SMD ceramic capacitor 0603	100PF/50V C0G ±5%(C1608C0G1H101JT)/TDK	C59,C128,C139,C140,C151,C154
107	CI00220	SMD ceramic capacitor 0603	220PF/50V C0G ±5%(C1608C0G1H221JT)/TDK	C71,C101
108	CI00223	SMD ceramic capacitor 0603	390PF/50V C0G ±5%(C1608C0G1H391JT)/TDK	C66
109	CI00226	SMD ceramic capacitor 0603	680PF/50V C0G ±5%(C1608C0G1H681JT)/TDK	C105
110	CK00005	SMD adjustment capacitor	V6P TZVY2Z060A110	VC2,VC3

No.	Part No.	Description	Specification	Remark
111	CK00010	SMD half adjustment capacitor	4.5 20PF N750 TZY2R200A001R00	VC1
112	CL00002	SMD tantalum capacitor RS ACT	1.0uF/16V case A	C99
113	CL00004	SMD tantalum capacitor RS ACT	4.7uF/20V case A(ELNA)	C126
114	CL00007	SMD tantalum capacitor RS ACT	10uF/10V case A	C92
115	CL00008	SMD tantalum capacitor	47uF/7V case B2	C143,C144
116	CL00011	SMD tantalum capacitor RS ACT	100uF/10V case C	C69,C119
117	CO00007	SMD chip inductance RS ACT	22uH(NLV32 220J PF)/(TDK)	L65
118	CO00067	SMD chip inductance RS	10nH±5%(MLG1608B10NJT)/(TDK)	L1,L9,L58,L59,L60,L61,L69,L70,L71
119	CO00069	SMD chip inductance RS	15nH±5%(MLG1608B15NJT)/(TDK)	L3,L6,L54
120	CO00076	SMD chip inductance RS	18nH±5%(MLG1608B18NJT)/(TDK)	L56
121	CO00088	SMD chip inductance RS	1.0uH±10%(MLF1608A1R0K)/(TDK)	L12
122	CO00093	SMD inductance	5.6nH±0.2nH(LQW18AN5N6C00D)/(MURATA)	L2
123	CO00094	SMD inductance	6.8nH±0.2nH(LQW18AN6N8C00D)/(MURATA)	L62
124	CO00095	SMD inductance	100nH±5%(SWI0603CTR10J)/(AOBA)	L57
125	CO00097	SMD inductance RS	80Ω±25%(MLB 160808 0080A N2)/(MALA)	L4,R27,T1,T4,T5,T6,T7,T8,T10,T11
126	CO00110	SMD chip inductance	4.7uH±5%(MLF1608A4R7J)/(TDK)	L8,L11,L66
127	CO00111	SMD inductance	100uH±20%(VLCF4020T 101MR26)/(TDK)	L68
128	CO00124	SMD chip inductance RS 0603	180nH±5%(MLG1608SR18JT)/(TDK)	L10
129	HL00005	push button switch RS	4.5*4.5*3.8mm TRAVEL=0.2	SW1,SW2
130	RD00059	SMD fixed resistor 1/10W	0.0Ω ±5% 0603	L63,R33
131	RD00061	SMD fixed resistor 1/10W	10Ω ±5% 0603	R9,R18
132	RD00062	SMD fixed resistor 1/10W	18Ω ±5% 0603	R10,R11,R17,R48
133	RD00063	SMD fixed resistor 1/10W	22Ω ±5% 0603	R29
134	RD00065	SMD fixed resistor 1/10W	47Ω ±5% 0603	R23,R89
135	RD00068	SMD fixed resistor 1/10W	100Ω ±5% 0603	R13,R14,R65
136	RD00075	SMD fixed resistor 1/10W	300Ω ±5% 0603	R51
137	RD00078	SMD fixed resistor 1/10W	470Ω ±5% 0603	R21
138	RD00083	SMD fixed resistor 1/10W	1.0KΩ ±5% 0603	R139,R2,R6,R7,R24,R37,R39,R49,R56,R79
139	RD00087	SMD fixed resistor 1/10W	2.0KΩ ±5% 0603	R28,R69
140	RD00088	SMD fixed resistor 1/10W	2.2KΩ ±5% 0603	R34,R60,R62,R80,R82,R88,R130
141	RD00091	SMD fixed resistor 1/10W	3.3KΩ ±5% 0603	R20,R26
142	RD00093	SMD fixed resistor 1/10W	4.7KΩ ±5% 0603	R3,R4,R5,R15,R16,R35,R36,R46,R55,R93
143	RD00095	SMD fixed resistor 1/10W	5.6KΩ ±5% 0603	R68,R96,R19
144	RD00099	SMD fixed resistor 1/10W	8.2KΩ ±5% 0603	R42
145	RD00101	SMD fixed resistor 1/10W	10KΩ ±5% 0603	R12,R25,R31,R32,R43,R45,R47,R53,R57,R63,R64,R66,R70,R74,R97,R100,R140
146	RD00102	SMD fixed resistor 1/10W	12KΩ ±5% 0603	R44,R54,R59,R75,R81,R85,R92
147	RD00103	SMD fixed resistor 1/10W	15KΩ ±5% 0603	R90,R101,R135
148	RD00105	SMD fixed resistor 1/10W	22KΩ ±5% 0603	R8,R22,R30,R41,R58,R72,R76,R84
149	RD00108	SMD fixed resistor 1/10W	33KΩ ±5% 0603	R71,R86,R87
150	RD00111	SMD fixed resistor 1/10W	47KΩ ±5% 0603	R77,R83,R95,R104,R136,R137,R138
151	RD00115	SMD fixed resistor 1/10W	82KΩ ±5% 0603	R131,R132,R133,R134
152	RD00116	SMD fixed resistor 1/10W	100KΩ ±5% 0603	R50,R61,R102,R143,R144
153	RD00119	SMD fixed resistor 1/10W	220KΩ ±5% 0603	R67,R99
154	RD00123	SMD fixed resistor 1/10W	470KΩ ±5% 0603	R98
155	RD00508	SMD fixed resistor 1/10W	430Ω ±5% 0603	R1,R38,R40
156	RF00001	SMD semi fixed resistor	EVN5ES X50B54 50K	VR1
157	RF00002	SMD semi fixed resistor	EVN5ES X50B24 20K	VR55,VR56
158	SE00006	SMD varactor	1SV270	VD2
159	SE00016	SMD zener diode	1/2W 5.1V(RLZ5.1B) LL 34	D8
160	SE00045	SMD Schottky barrier diode RS	1A/30V FS1J3	D4,D5
161	SE00059	SMD varactor	BB142/(PHI)	VD1
162	SE00061	SMD rectifier diode	1SS355 TE17/(ROHM)	D1,D2,D3,D9,D10,D11
163	SE00070	SMD Schottky barrier diode RS	0.7A/400V S07G	D6,D7
164	SF00004	SMD transistor RS ACT	2SA1036K(SC59)/(ROHM)	Q17
165	SF00005	SMD transistor RS ACT	2SA1797Q(SC62)/(ROHM)	Q15

No.	Part No.	Description	Specification	Remark
166	SF00010	SMD transistor RS ACT	2SC2412K(SC59)/(ROHM)	Q4,Q5,Q10,Q11,Q14,Q16
167	SF00020	voltage stabilized transistor	3.0V XC62FP3002MR(SOT23)/(TOREX)	IC2,IC59
168	SF00042	transistor	XP151A13A0MR(SOT23)/(TOREX)	Q2,Q13
169	SF00050	transistor	XC9103D093MR(SOT25)/(TOREX)	IC58
170	SF00067	transistor	BFG425W/(PHI)	Q1,Q3,Q6,Q7,Q8
171	SF00068	transistor	2SK2731 T146/(ROHM)	Q9
172	SF00069	transistor	RTR030P02 TL(TSMT3)/(ROHM)	Q12
173	SF00078	transistor	DTC614TU(UMT3)/(ROHM)	Q18
174	SG00007	SMD integrated circuit	MB15E03SLPFV ER(SOP16)/(FUJITSU)	IC1
175	SG00040	SMD integrated circuit	MC33078DT/MC33078D(SO8)/(ST/MOTOROLA)	IC55
176	SG00122	SMD integrated circuit RS ACT	NJM4580M TE3(SOP8)/(JRC)	IC56
177	SG00207	SMD integrated circuit	24LC00T/OT(SOT23)/(MICROCHIP)	U131
178	SG00315	integrated circuit	PIC16F74 I/PT(TQFP44)/(MICROCHIP)	U132
179	SG00373	SMD integrated circuit	SA575DTBR2(TSSOP20)/(ON)	IC3
180	CI00077	SMD ceramic capacitor 0603	1.2PF/50VC0G±0.25PF(C1608C0G1H1R2CT)TDK	C31
181	RD00306	SMD fixed resistor 1/10W	20KΩ ±5% 0603	R78
182	MI02867	separating shade RS ACT	UP 8H 0.2*4.8*23.1*29.1 V1.4	
183	MJ01314	tinplate	0.2t*40*1M(1M/0.5KG) V 1.0	
184	MI03098	separating shade RS ACT	UP 8P 0.2*2.8*14.2*14.3 V1.5	
185	MJ01314	tinplate	0.2t*40*1M(1M/0.5KG) V 1.0	
186	AE00449	solder material without lead	9308/Sn Ag Cu	
187	SE00067	SMD L.E.D	blue 12 215/BHC AN1P2/3C	LED1,LED2
188	CO00005	SMD chip inductance	1uH(1R0K)	L5
189	RD00376	SMD precise resistor 1/8W	150Ω ±1% 0805	R52

AU-800P

No.	Part No.	Description	Specification
1	NI01291	plastic chassis	WR-101R
2	NI01128	top cover	WR-101R
3	NI01132	top cover	WR-101R black
4	HF00009	telescopic antenna-RS	YH860417 (4S*385m/m)
5	NI00303	tuning knob	DM-80 black
6	NI00510	self-adhere foot cushion	RF10-3
7	MI00637	antenna fixed socket-RS-ACT	WR-101 V2.0
8	MJ00069	iron board	1.5*2135*1220 30.67kg
9	HA01871	signal wiring-RS	φ6.3*φ5*φ6.3*5FT
10	TG00009	adaptor	230V/50Hz 12V/300mA EI-41_CE
11	NE02059	label	MBD700 TONSIL
12	NE01783	label	black
13	NI00040	adhesive label	0.065*1M
14	NI00018	membrane	0.06*1M
15	MG00090	color screw	M3*10
16	MG00147	screw	M1.7*4
17	MG00166	screw	M3*10
18	MF00037	washer	φ3.2*φ5.5*1t
19	NF00633	instruction	WR-101R nil brand number
20	NA00120	PE bag	0.04t*220*200mm
21	NB01378	gift carton-RS	WR-101R no trademark number
22	NB01267	carton	WR-101R,102DR,211R
23	MI00617	separating shade top cover-RS-	WR-1XXR,DR V1.3
24	MJ01185	tin plate	0.33t*700*910mm 1.6kg V1.1
25	MI00619	separating shade top cover-RS-	WR-1XXR;DR V1.3
26	MJ01185	tin plate	0.33t*700*910mm 1.6kg V1.1
27	NI01272	handle	for wireless coloful box
28	NE02414	label	TONSIL
29	NH00020	bond paper	0.1*1M
30	NI00025	membrane	0.095*1M
31	NE02448	label	green
32	NH00014	bond paper	0.05*1M white
33	NI00034	membrane	0.045*1M
34	NE00610	label	CE
35	NH00022	bond paper	0.12*1M
36	NI00029	membrane	0.115*1M
37	NE02336	label	ETS EMC-TEST
38	NH00019	bond paper	0.095*1M
39	NI00024	membrane	0.09*1M
40	HJ00001	dessicant	5g
41	NA00115	PE bag	0.04t*300*80mm