

Service Manual

Model: α VERB

24x32 BIT DIGITAL EFFECTS



www.altoproaudio.com

Version: 1.1

CONTENTS

- 1. Specification**
- 2. Block Diagram**
- 3. Schematic Diagram**
- 4. Printed Circuit Board**
- ~~**5. Wiring Diagram**~~
- 6. Test Procedure**
- 7. Electrical Parts List**
- 8. Exploded Views & Mechanical Parts List**
- 9. Notes**

1. SPECIFICATION (aVERB)

Electrical

Frequency Response:	+0.5 / -1.5 dB from 20Hz to 20 kHz
S/N Ratio (process)	80 dB "A" wtg, 20 Hz-22kHz
S/N Ratio (bypass)	>90 dB "A" wtg, 20 Hz-22kHz
THD+Noise:	<0.008% @ 1kHz (0dBV, bypass)

Input

Number of Channels:	2
Format:	1/4" unbalanced
Maximum Level (bypass):	+9 dBu
Impedance:	>500 Kohms

A/D - D/A Conversions

A/D converter:	1 bit Sigma-Delta
D/A converter:	1 bit Sigma-Delta

Output

Number of Channels:	2
Format:	1/4" unbalanced
Maximum Level (bypass):	+9 dBu
Output Impedance:	<500 ohms

Front Panel

Controls	Input/Output Levels (ANALOG) PROGRAM selections (2 knobs)
Indicators	Power, Signal clip LED

Rear Panel

IN/OUT levels (ANALOG)	1/4" 2-conductor (mono)
Output (LEFT, RIGHT)	1/4" 2-conductor (mono)
BYPASS	1/4" 2-conductor (auto-sense pedal type) for momentary footswitches
Power	9 Volt AC Power Transformer

Processing and Memory

Processor Speed:	12 MIPS (million instructions per second)
Internal DSP resolution:	52 bit MPY accumulator
Main Preset Programs	16
Preset Total Combinations	256
Internal digital audio memory:	3000 milliseconds

Physical

Net Weight:	1kg(2.20lb)
Dimension(WxDxH):	200(mm) 150(mm) 45(mm) (7.87" x 5.91"x 1.77")

alphaverb BLOCK DIAGRAM

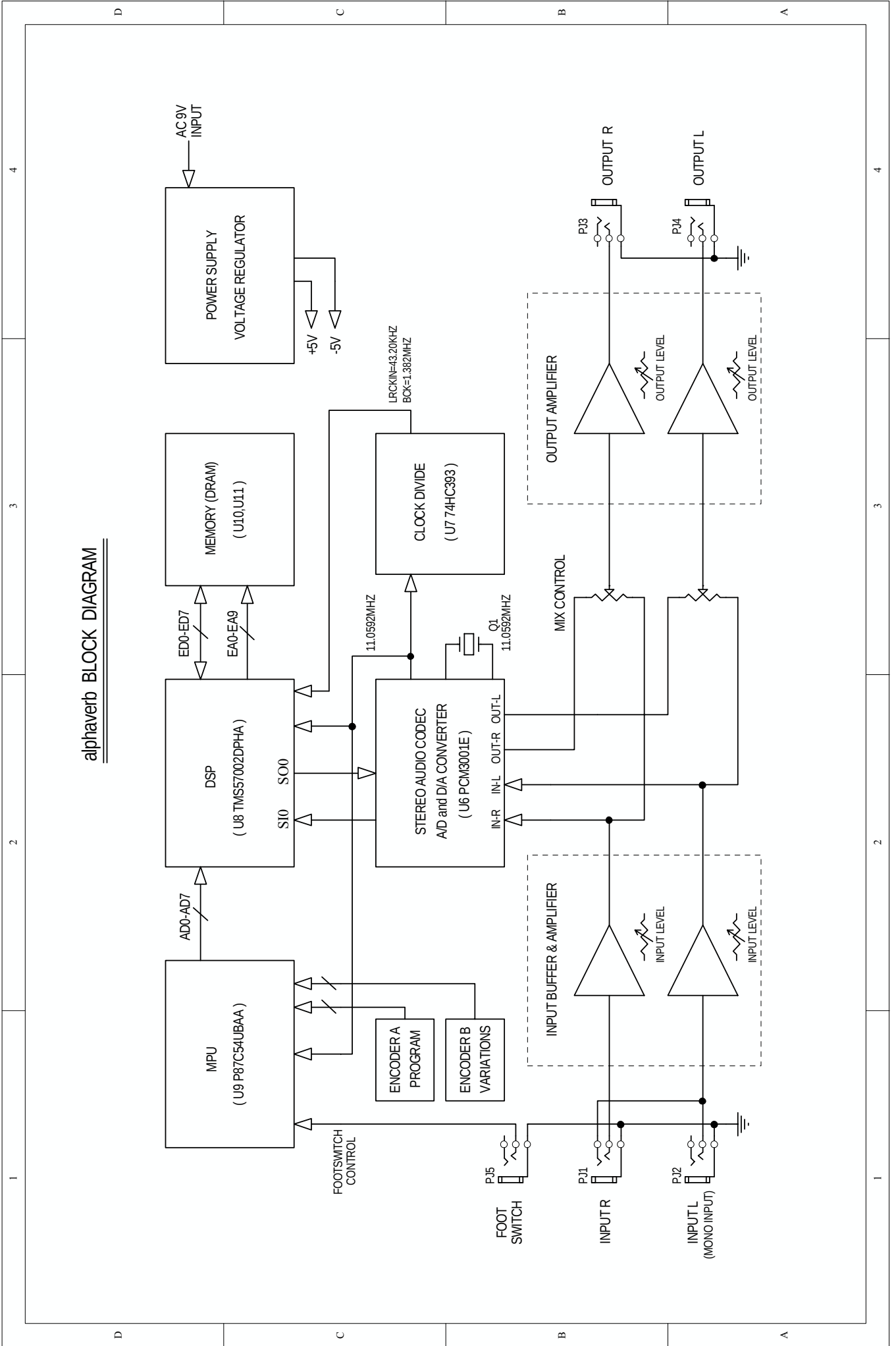

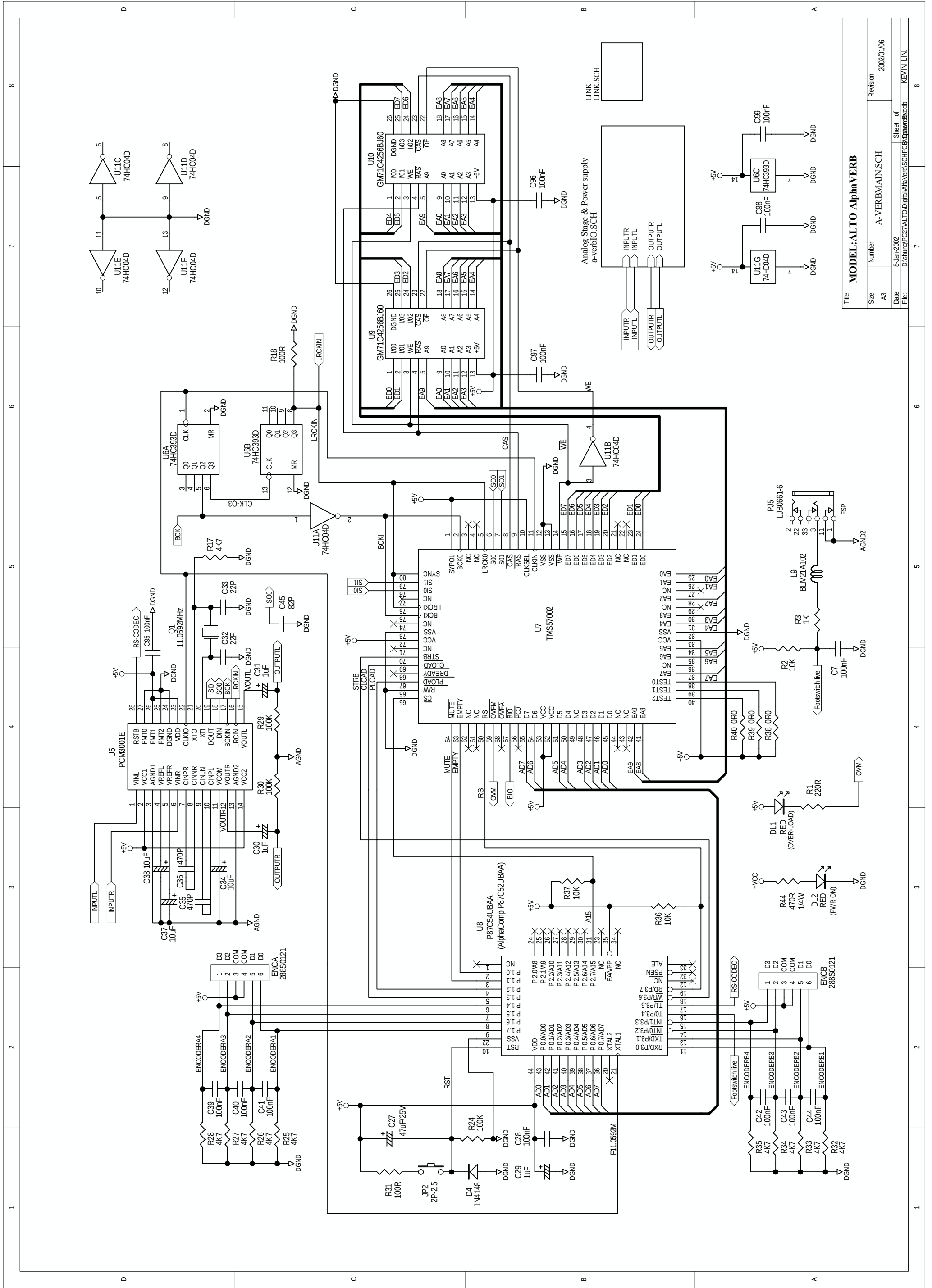

MODEL:ALTO AlphaVerb

Title	Model:ALTO AlphaVerb
Size	A3
Number	A-VERBMAIN.SCH
Revision	2002/01/06
Date:	8-Jan-2002
File:	D:\stung\PC27\ALTO\Digital\AltoVerb\SCHPCB\AlphaVerb.dtb

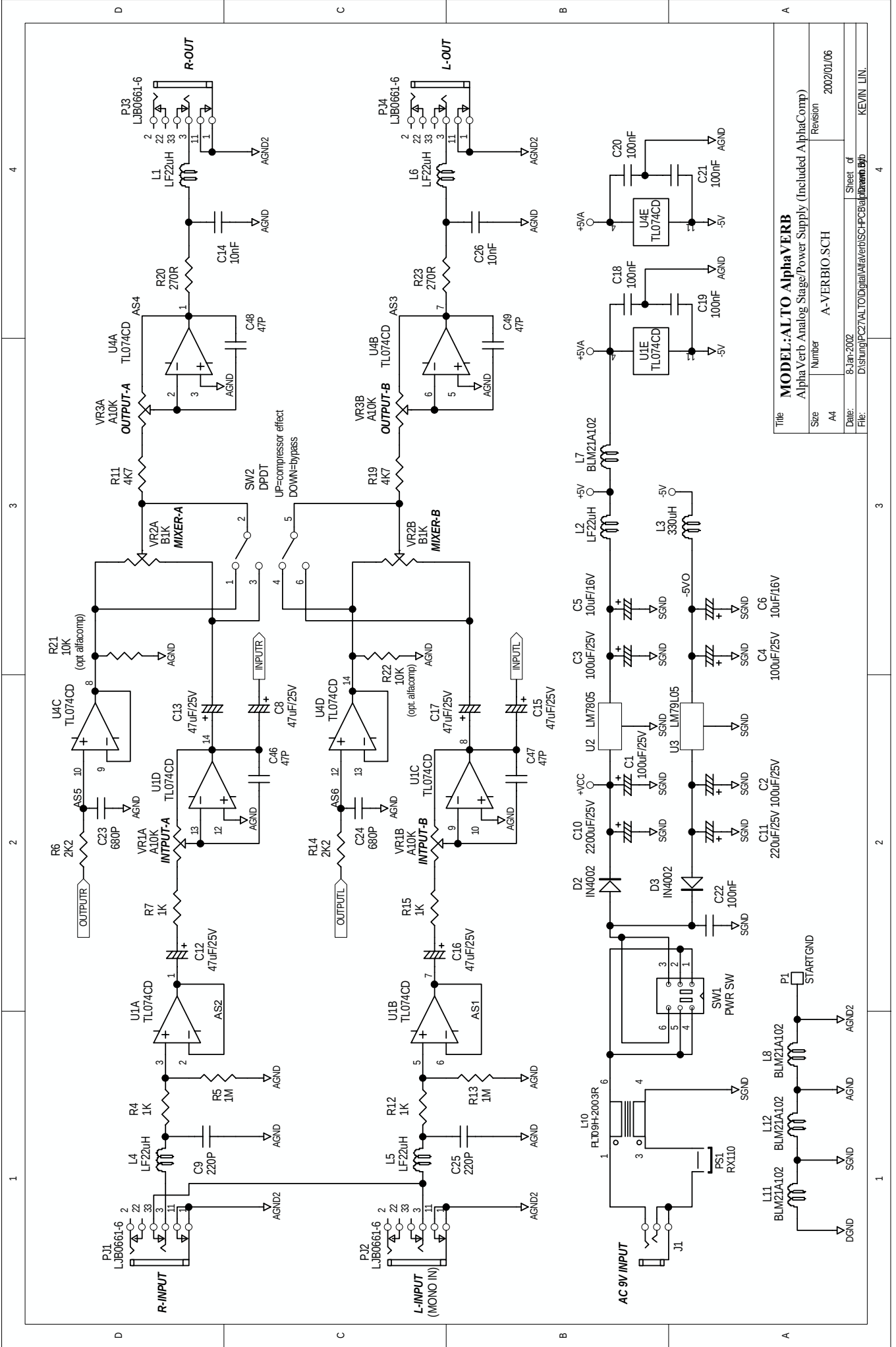

Title		MODEL: ALTO AlphaVerb	
Alpha Verb Analog Stage/Power Supply (Included AlphaComp)		Revision	
Size	Number	A-VERBIO.SCH	2002/01/06
A4	Date:	8-Jan-2002	Sheet of
File:	D:\shrimp\PC7\ALTO\Digital\AltaVerb\SCH\PCB\alverbio.sch		4
			KEVIN LIN.

BOTTOM LAYER

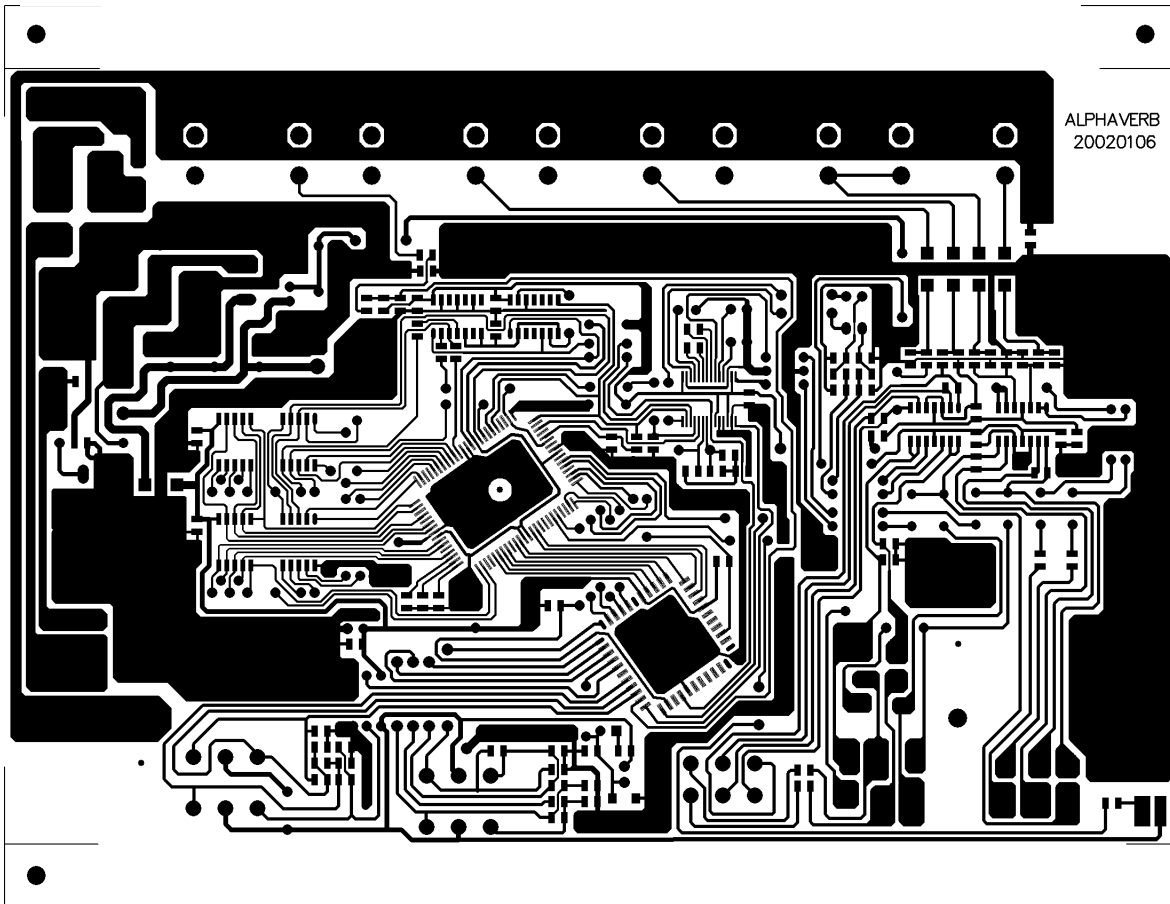

BOTTOM SOLDER MASK

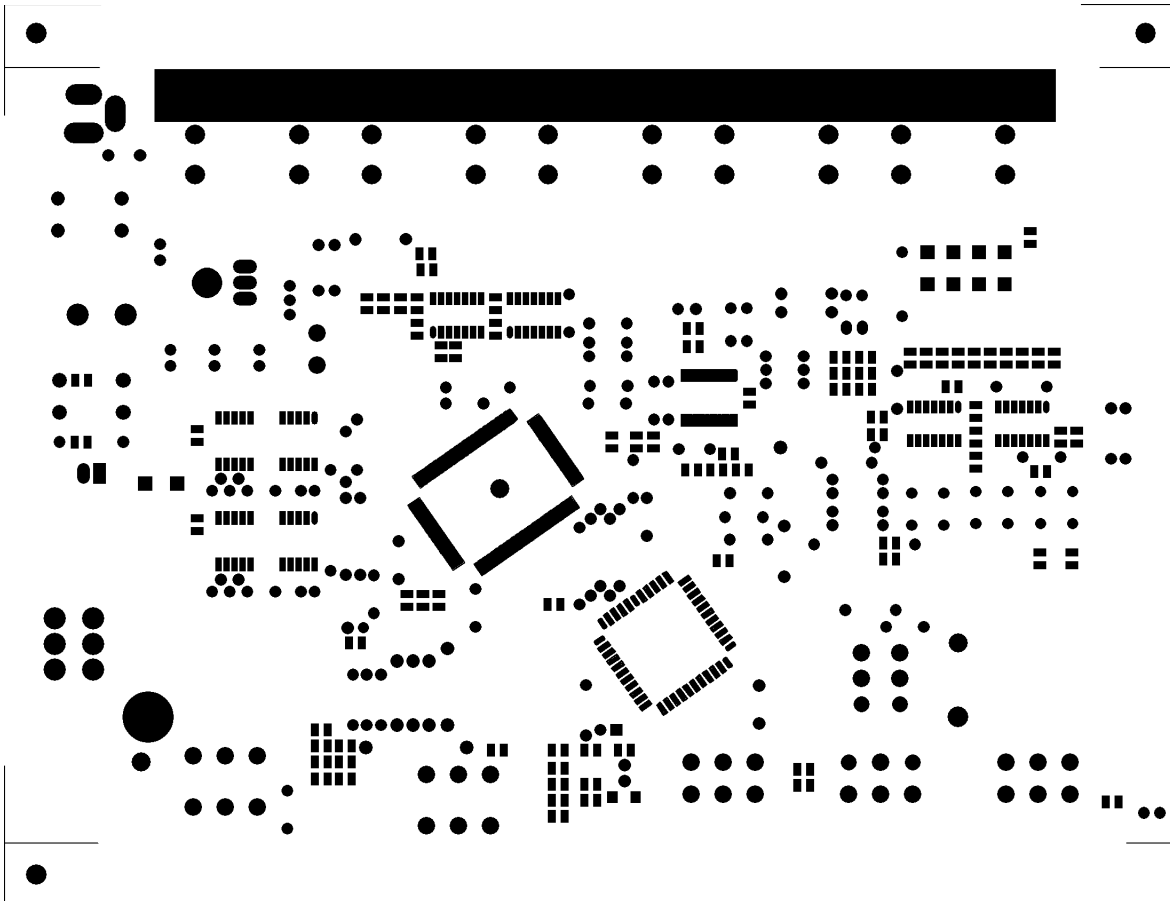

BOTTOM SILKSCREEN

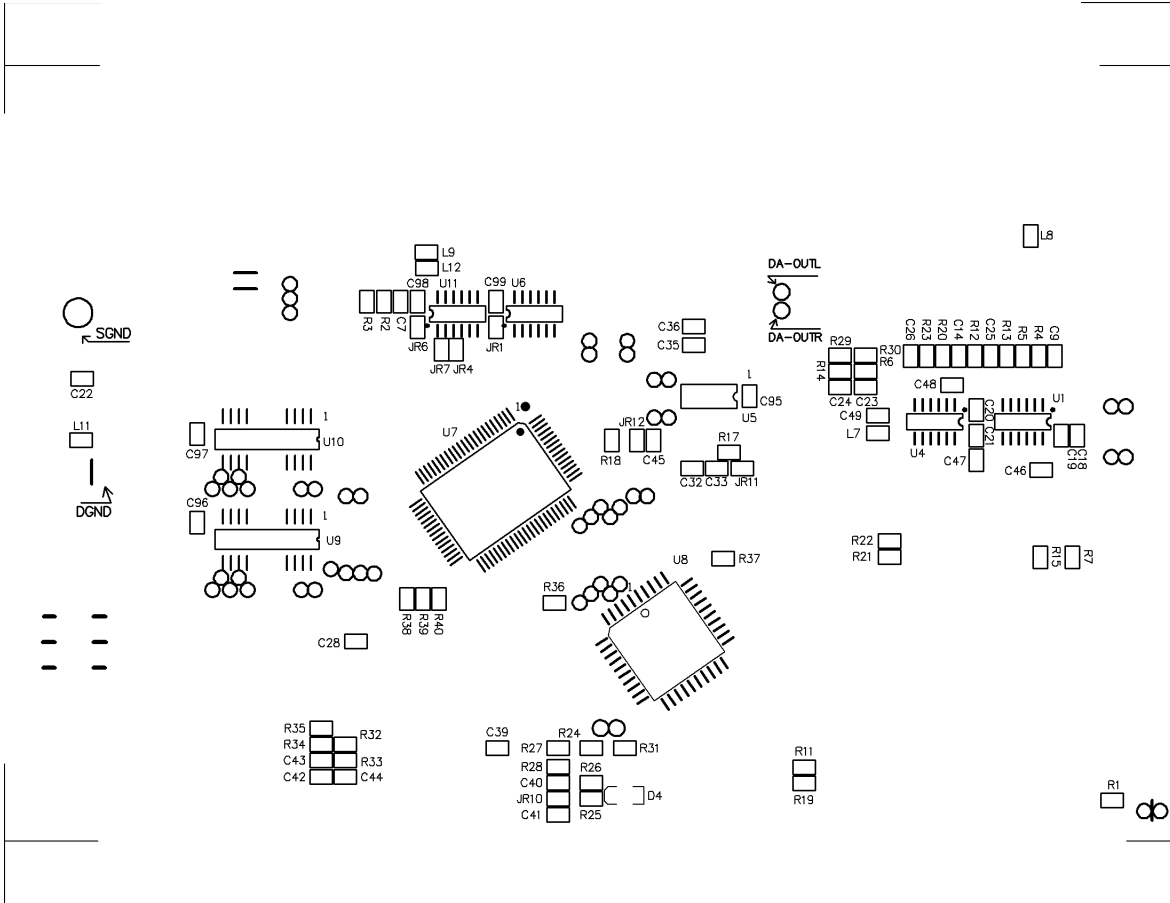

TOP SILKSCREEN

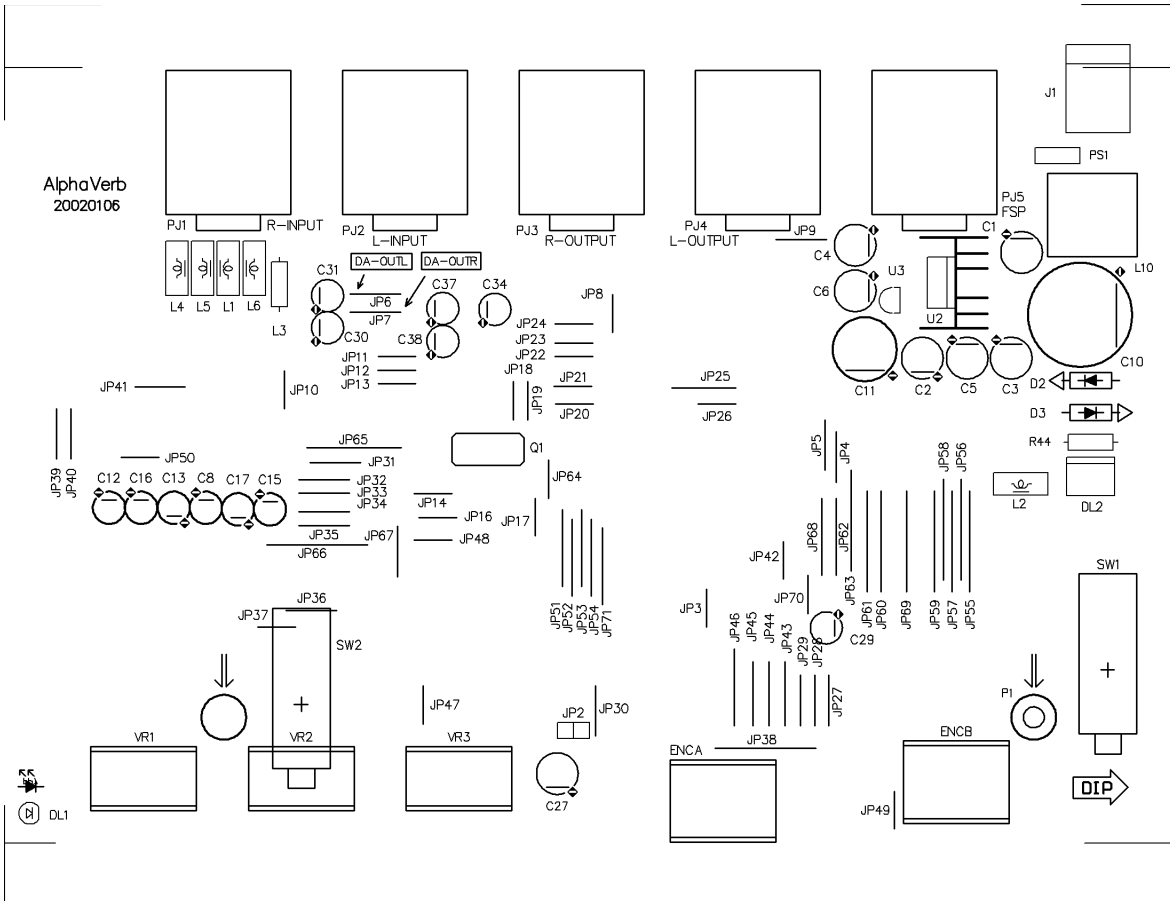

DRILL DRAWING

A = BUTTONHOLE 1.3*2.6-2HOLES
 B = BUTTONHOLE 1.3*3.3-1HOLES

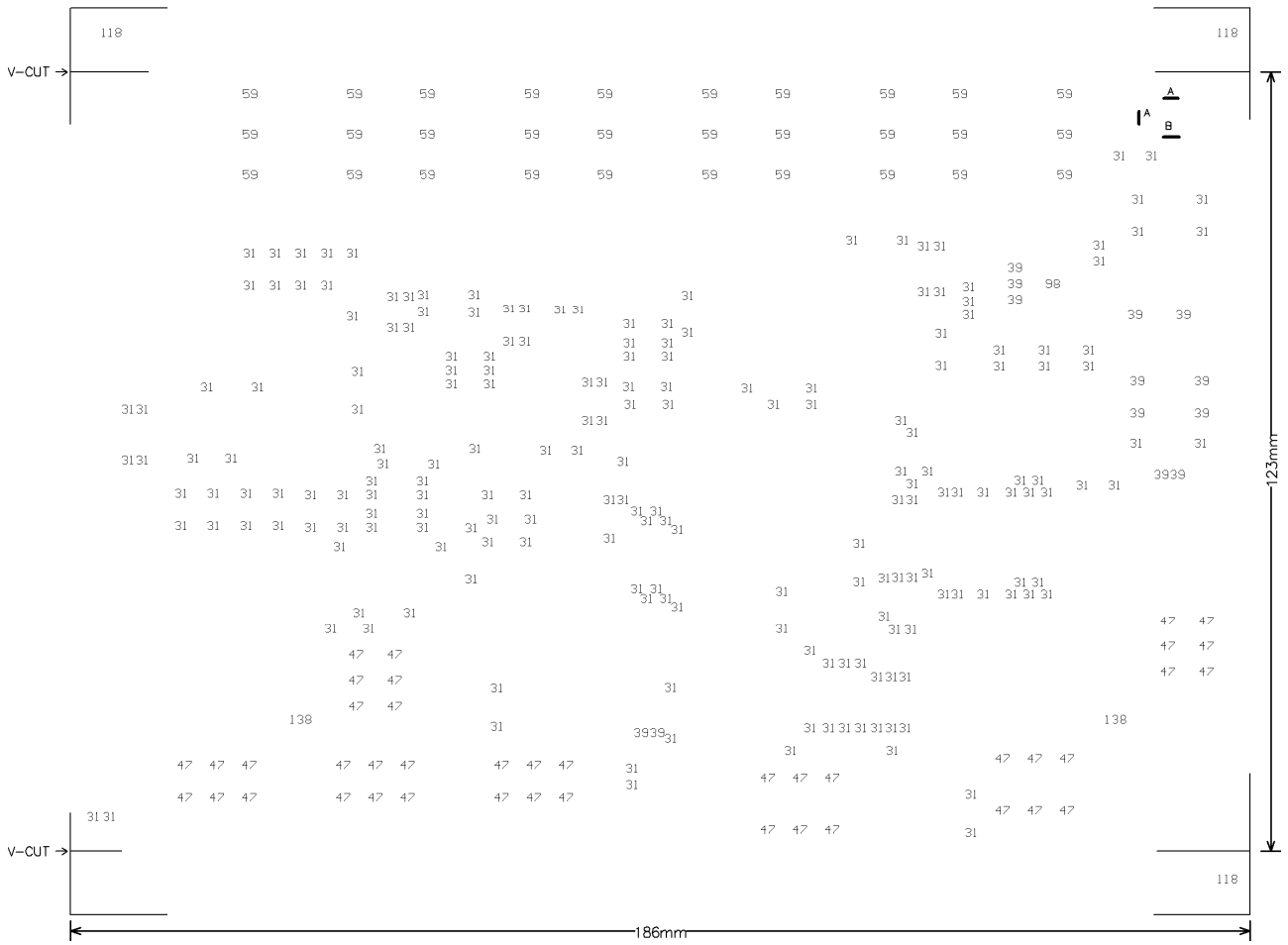

Tool	Hole Size	Hole Count Plated
T1	31mil (0.80mm)	203
T2	39mil (1.00mm)	13
T3	47mil (1.20mm)	42
T4	59mil (1.50mm)	30
T5	98mil (2.50mm)	1
T6	118mil (3.00mm)	3
T7	138mil (3.50mm)	2
Totals		294

Alpha Verb
20020106

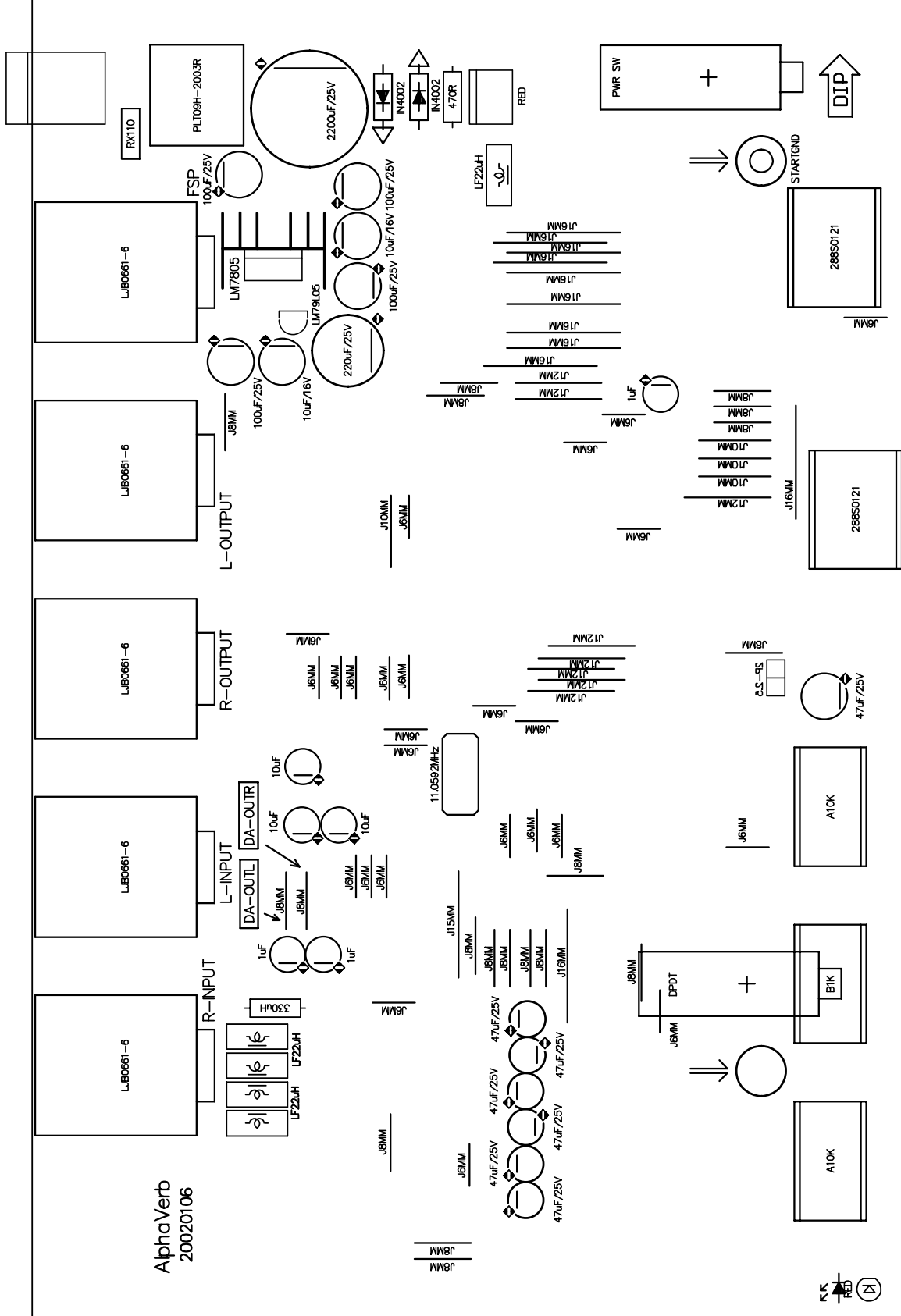

K.S.

G1 Test Procedures (aVERB)

Required Equipment

Audio Precision System 2 with APWin software
100 Mhz oscilloscope connected to APS2 Analyzer Signal Monitor outputs (Ch. A and Ch. B)

Connection Mode

Use Audio Precision System 2 analog unbalanced (BNC) inputs/outputs.

Test Procedures for AlphaVerb

Amplitude response test

On PC:

-Load file: **alfaverb_amplitude** (APWin File menu / Open / Test)

Test Connections:

- Output A of Audio Precision System Two --> LEFT input of the device under test.**
- LEFT output of the device under test --> A input of Audio Precision System Two**
- RIGHT output of the device under test --> B input of Audio Precision System Two**

On the Alphaverb:

- Turn on the power switch.
- Set INPUT volume to maximum.
- Set OUTPUT volume to maximum.
- Set PROGRAM to **DELAY**.
- Set VARIATION to 1.

Start the sweep (F9) and control the results (Page3 – Graph) in the following conditions:

- MIX potentiometer turned to 0.**
- MIX potentiometer turned to 10.**

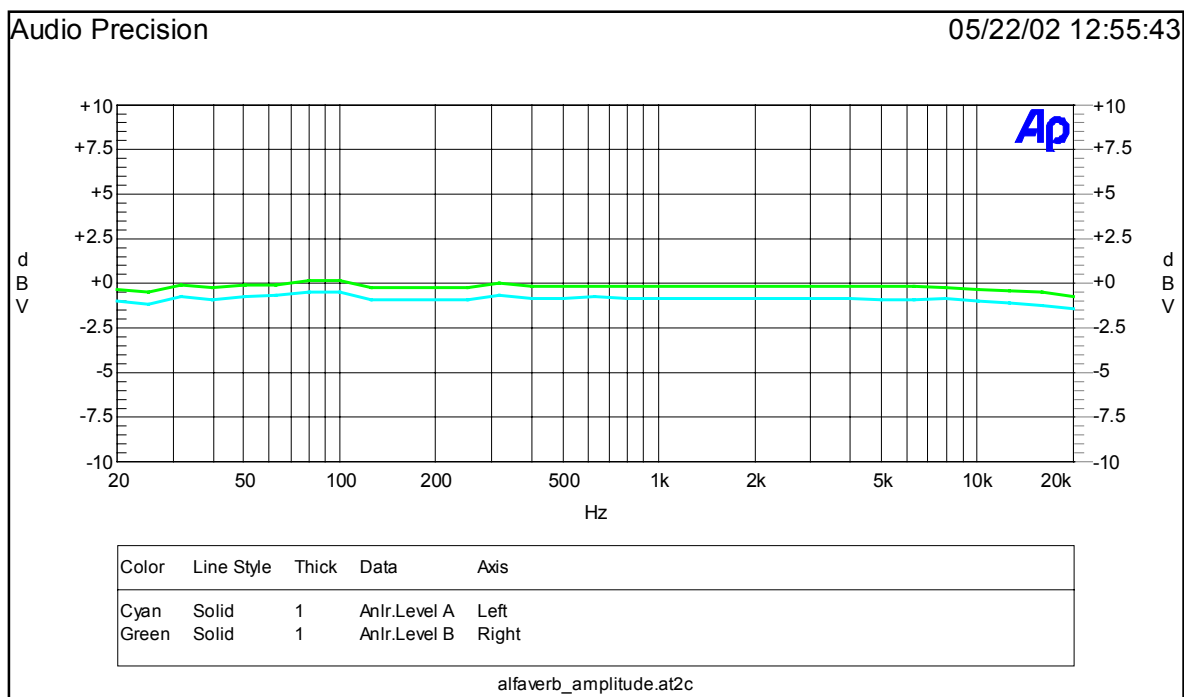

THD test

On PC:

-Load file: **alfaverb_THD** (APWin File menu / Open / Test)

Test Connections:

-Output A of Audio Precision System Two --> LEFT input of the device under test.

On the Alphaverb:

- Turn on the power switch.
- Set INPUT volume to maximum.
- Set OUTPUT volume to maximum.
- Set PROGRAM to **DELAY**.
- Set VARIATION to 1.

Start the sweep (F9) and control the results (Page3 – Graph) in the following conditions:

- LEFT output of the device under test --> A input of Audio Precision System Two / MIX potentiometer turned to 10**
- RIGHT output of the device under test --> B input of Audio Precision System Two / MIX potentiometer turned to 10**

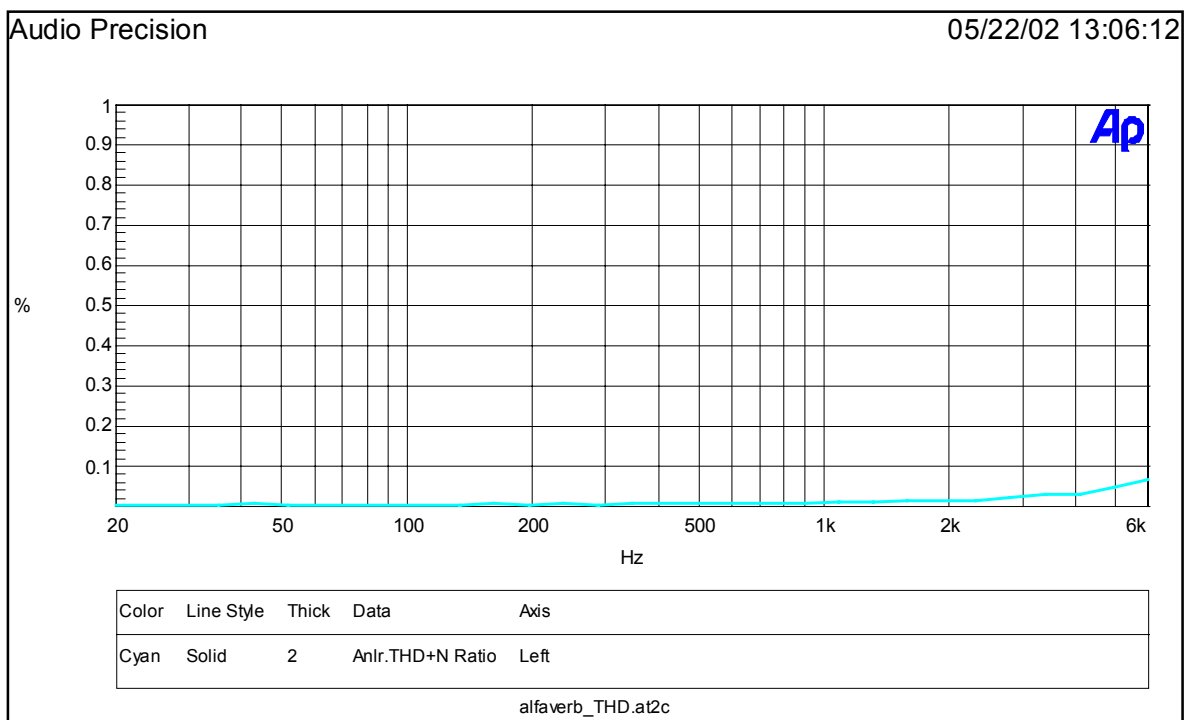

S/N test

On PC:

-Load file: **alfaverb_SN** (APWin File menu / Open / Test)

Test Connections:

-Output A of Audio Precision System Two --> LEFT input of the device under test.

On the Alphaverb:

-Turn on the power switch.

-Set OUTPUT volume to maximum.

- With MIX command turned to 10, increase the INPUT level until the device's outputs clip, and after reduce the INPUT level itself until the outputs exit from clipping state.

-Set PROGRAM to **DELAY**.

-Set VARIATION to 1.

Start the sweep (F9) and control the results (Page3 – Graph) in the following conditions:

-LEFT output of the device under test --> A input of Audio Precision System Two / MIX potentiometer turned to 10

-RIGHT output of the device under test --> B input of Audio Precision System Two / MIX potentiometer turned to 10

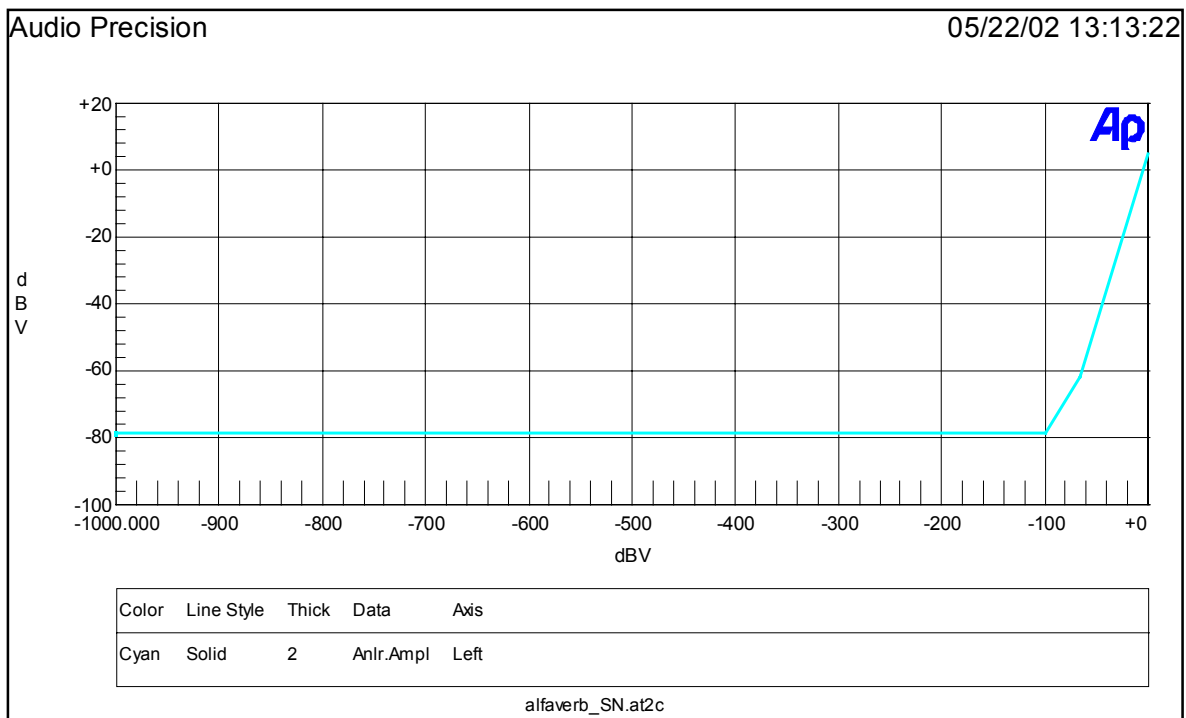

Dynamics test

On PC:

-Load file: **alfaverb_dyn** (APWin File menu / Open / Test)

Test Connections:

-Output A of Audio Precision System Two --> LEFT input of the device under test.

On the Alphaverb:

- Turn on the power switch.
- Set INPUT volume to maximum.
- Set OUTPUT volume to maximum.
- Set PROGRAM to **DELAY**.
- Set VARIATION to 1.

Start the sweep (F9) and control the results (Page3 – Graph) in the following conditions:

-LEFT output of the device under test --> A input of Audio Precision System Two / MIX potentiometer turned to 10

-RIGHT output of the device under test --> B input of Audio Precision System Two / MIX potentiometer turned to 10

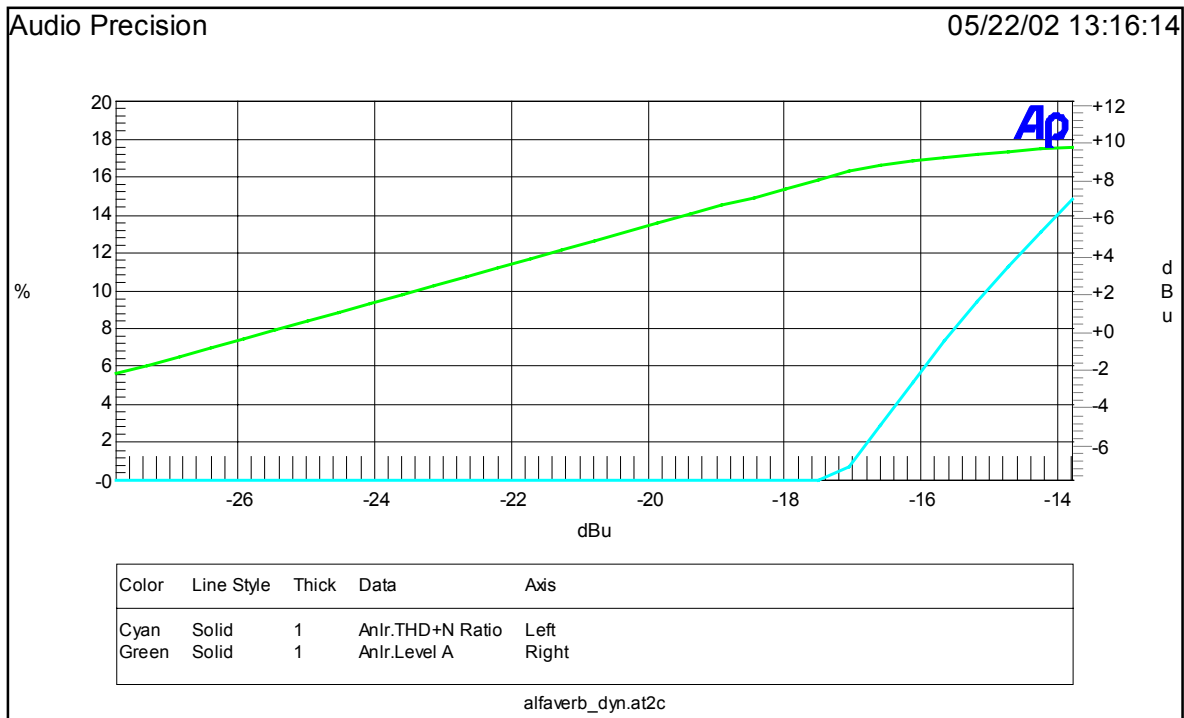

Stability test

On PC:

-Load file: **alfaverb_stability** (APWin File menu / Open / Test)

Test Connections:

- Output A of Audio Precision System Two --> LEFT input of the device under test.**
- LEFT output of the device under test --> A input of Audio Precision System Two**
- RIGHT output of the device under test --> B input of Audio Precision System Two**

On the Alphaverb:

- Turn on the power switch.
- Set OUTPUT volume to maximum.
- Set INPUT volume to zero.
- Set PROGRAM to **DELAY**.
- Set MIX potentiometer to 0.
- Set VARIATION to 1.

Test:

Move the input level knob from 0 to maximum 3 times and control the output waveforms: NO PERMANENT SINE WAVEFORMS should be visible. IF PERMANENT WAVEFORMS WITH FREQUENCY > 20 kHz should become visible on whatever output channel, THE UNIT IS TO BE INSPECTED.

Structure Needing Material Detail List

建檔日: 2002/03/05 修正日: 2002/05/03

<u>NO.</u>	<u>Midprod NO</u>	<u>Quantity</u>	<u>Unit</u>
1	A-aVERB-ALTO-230V-歐洲	1.000	PCS
2	A-aVERB 底後板組合	1.000	PCS
3	P-aVERB-SMD	1.000	PCS
4	P-aVERB-DIP	1.000	PCS

Item No: aVERB

specify: AMP

Mid No: standard quantity:

NO	Material No	Item Name	Specific	Quantity	Unit	Ps
1	MFRZ03ZZ	panel	aVERB ALTO	1.000	PCS	
MARK:						
2	MTPZ02ZZ	top cover (black)	aVERB	1.000	PCS	
MARK:						
3	MBKZ01ZZ	rear board	aVERB	1.000	PCS	
MARK:						
4	NMBP65	plastic knob double $\phi 2$		1.000	PCS	
MARK:						
5	NMBP64	plastic knob double $\phi 1$		3.000	PCS	
MARK:						
6	NPL272		$\phi 8.5*4$ blue 072C	3.000	PCS	
MARK:						
7	NMBA01	power push button	$\phi 15*12$	1.000	PCS	
MARK:						
8	NPL286	switch cap	$\phi 14.5*10$ YELLOW C	1.000	PCS	
MARK:						
9	MSCB13	black-plated screw	cross-head pan head 3*6	10.000	PCS	
MARK:						
10	MSCN20	Ni screw	flat 3*8	2.000	PCS	
MARK:						
11	MSCB38	black plated screw	3*7	4.000	PCS	
MARK:						
12	NC00131	washer	1* $\phi 11.3* \phi 15.3$ red	5.000	PCS	
MARK:						
13	HCSM37-2	nut of plastic	$\phi 7/16''*G20/15*4.8$ (hexag	5.000	PCS	
MARK:						
14	MFS016	washer	$\phi 3* \phi 6.5*0.5t$	2.000	PCS	
MARK:						
15	HLSF126	row-wire connector wirir 2P 100m/m		1.000	PCS	
MARK:						
16	DL43RG	L.E.D	LG2043 green	1.000	PCS	
MARK:						
17	NMCT16Ww0010	sleeving flame retardant 2.5 $\phi *10m/m$		2.000	PCS	
MARK:						
18	TP4035	voltage transformer EI- λ 230V/50Hz.AC9V/300mA		1.000	PCS	
MARK:						
19	NMCQA-005	instruction	aVERB	1.000		
MARK:						
20	HEM-002	desiccant	10g	1.000	PCS	
MARK:						
21	NWCP01Ww0230*0350	PE bag	23*35cm	1.000	PCS	
MARK:						
22	NWCP04	lockable bag	5*7	1.000	PCS	
MARK:						
23	NI01825	cushion	0.5* $\phi 3.3* \phi 8.3$ aVERB	1.000	PCS	
MARK:						
24	NWCP39		13*16mm	1.000	PCS	
MARK:						
25	NLXM39	self-paste foot pad(SF-C 12.7*9.0*3.0t		4.000	PCS	
MARK:						
26	NMLH966ZZ	label	aVERB CKS:4172	1.000		
MARK:						
27	NB01479	box	aVERB	1.000	PCS	
MARK:						

Item No: aVERB

specify: AMP

Mid No: A-aVERB-ALTO-230V-歐洲 standard quantity: 1.000

<i>NO</i>	<i>Material No</i>	<i>Item Name</i>	<i>Specific</i>	<i>Quantity Unit</i>	<i>Ps</i>
28	POA002	paper outter case 8hole	aVERB	0.125 PCS	
MARK:					
29	MAPI64ZZ	fixed board	132*20*5 aVERB	1.000 PCS	
MARK:					
30	NMLM372ZZ	label	aVERB	4.000	
MARK:					
31	NE05004	label	ALTO	4.000	
MARK:					
32	NMLH31	label	MADE IN P.R.C.	2.000	
MARK:					

Item No: aVERB

specify: AMP

Mid No: A-aVERB 底後板組合 standard quantity: 1.000

<i>NO</i>	<i>Material No</i>	<i>Item Name</i>	<i>Specific</i>	<i>Quantity</i>	<i>Unit</i>	<i>Ps</i>
1	MBTZ04ZZ	bottom board(black)	aVERB	1.000	PCS	
MARK:						
2	MMC014	iron pillar	hexagon 6.35*M3*9.2	2.000	PCS	
MARK:						

Item No: aVERB

specify: AMP

Mid No: standard quantity:

NO	Material No	Item Name	Specific	Quantity	Unit	Ps
1	NPC0101	PCB	aVERB	1.000	PCS	
MARK:						
2	RFCE000	SMD 1/10W fixed resistor	0Ω ±5% 0805	10.000	PCS	
MARK:	JR 1 10 11 12 4 6 7 R38 R39 R40					
3	RFCE110	SMD 1/10W fixed resistor	100Ω ±5% 0805	2.000	PCS	
MARK:	R 18 31					
4	RFCE122	SMD 1/10W fixed resistor	220Ω ±5% 0805	1.000	PCS	
MARK:	R 1					
5	RFCE127	SMD 1/10W fixed resistor	270Ω ±5% 0805	2.000	PCS	
MARK:	R 20 23					
6	RFCE210	SMD 1/10W fixed resistor	1.0KΩ ±5% 0805	5.000	PCS	
MARK:	R 12 15 3 4 7					
7	RFCE222	SMD 1/10W fixed resistor	2.2KΩ ±5% 0805	2.000	PCS	
MARK:	R 14 6					
8	RFCE247	SMD 1/10W fixed resistor	4.7KΩ ±5% 0805	11.000	PCS	
MARK:	R 11 17 19 25 26 27 28 32 33 34 35					
9	RFCE310	SMD 1/10W fixed resistor	10KΩ ±5% 0805	3.000	PCS	
MARK:	R 2 36 37					
10	RFCE410	SMD 1/10W fixed resistor	100KΩ ±5% 0805	3.000	PCS	
MARK:	R 24 29 30					
11	RFCE510	SMD 1/10W fixed resistor	1.0MΩ ±5% 0805	2.000	PCS	
MARK:	R 13 5					
12	CCC022B	SMD0805 ceramic capacitc	22PF NPO -50V	2.000	PCS	
MARK:	C 32 33					
13	CCC047B	SMD0805 ceramic capacitc	47PF NPO -50V	4.000	PCS	
MARK:	C 46 47 48 49					
14	CCC082B	SMD0805 ceramic capacitc	82PF NPO -50V	1.000	PCS	
MARK:	C 45					
15	CCC122B	SMD0805 ceramic capacitc	220PF NPO -50V ±5%	2.000	PCS	
MARK:	C 25 9					
16	CCC147B	SMD0805 ceramic capacitc	470PF NPO -50V ±5%	2.000	PCS	
MARK:	C 35 36					
17	CCC168B	SMD0805 ceramic capacitc	680PF NPO -50V	2.000	PCS	
MARK:	C 23 24					
18	CCC310F	SMD0805 ceramic capacitc	0.01uF Y5V -50V	2.000	PCS	
MARK:	C 14 26					
19	CCC410F	SMD0805 ceramic capacitc	0.1uF Y5V -50V	18.000	PCS	
MARK:	C 18 19 20 21 22 28 39 40 41 42 43 44 7 95 96 97 98 99					
20	DRS0005	SMD rectifier diode	RLS4148 0.5A (LL-34)	1.000	PCS	
MARK:	D 4					
21	SICS705	SMD integrated circuit	74HC04DT	1.000	PCS	
MARK:	J 11					
22	SICS708	SMD integratd circuit	74HC393DT	1.000	PCS	
MARK:	J 6					
23	SICS003	SMD integrated circuit	TL074CDT	2.000	PCS	
MARK:	J 1 4					
24	SICS305	SMD integratd circuit	PCM3001E	1.000	PCS	
MARK:	J 5					
25	SICS804	SMD integrated circuit	P89C54UBAA	1.000	PCS	此IC須燒錄程序
MARK:	J 8					

Item No: aVERB

specify: AMP

Mid No: standard quantity:

<i>NO</i>	<i>Material No</i>	<i>Item Name</i>	<i>Specific</i>	<i>Quantity Unit</i>	<i>Ps</i>
26	HBE004	SMD integrated circuit	SEED TMS57002DPHA	1.000 PCS	
MARK:	J 7				
27	HBE005	SMD integrated circuit	SEED MB81C4256A-60	2.000 PCS	
MARK:	J 10 9				
28	MCOS003	SMD chip inductance	BLM21A102SPT	5.000 PCS	
MARK:	L 11 12 7 8 9				

Item No: aVERB

specify: AMP

Mid No: standard quantity:

NO	Material No	Item Name	Specific	Quantity	Unit	Ps
1	RFB147S	1/4W fixed resistor	470Ω S type	1.000	PCS	
MARK:	R 44					
2	CE510S	electrolytic capacitor	1/50V ψ4*7	3.000	PCS	
MARK:	C 29 30 31					
3	CE610N	electrolytic capacitor	10/16V ψ4*7	5.000	PCS	
MARK:	R 34 37 38 5 6					
4	CE647E-1	electrolytic capacitor	47/25V	6.000	PCS	
MARK:	C 12 13 15 16 17 8					
5	CE647E	electrolytic capacitor	47/25V	1.000	PCS	
MARK:	C 27					
6	CE710E	electrolytic capacitor	100/25V	4.000	PCS	
MARK:	C 1 2 3 4					
7	CE722E	electrolytic capacitor	220/25V	1.000	PCS	
MARK:	C 11					
8	CE822V	electrolytic capacitor	2200/25V φ16*25mm	1.000	PCS	
MARK:	C 10					
9	DR001A	rectifier diode	1N4002/100V	2.000	PCS	
MARK:	D 2 3					
10	SIC714	integrated circuit	7805	1.000	PCS	
MARK:	J 2					
11	STR707	voltage stabilized trans	79L05(T0-92)	1.000	PCS	
MARK:	J 3					
12	SQR11.0592	quartz crystalloid	11.0592HC-49/US ±20PPM	1.000	PCS	
MARK:	Q 1					
13	MC0049	inductor	330uH(LGA0308-331K)	1.000	PCS	
MARK:	L 3					
14	C00038	EMI FILTER (filter)	LF-22UH(WAH TAYI)	5.000	PCS	
MARK:	L 1 2 4 5 6					
15	HSWF19	waveband switch	288S0121	2.000	PCS	ENCA, ENCB
MARK:						
16	HSWE15	button SW(double link-ac)	PS-9AN-022-18B long foot	1.000	PCS	
MARK:	SW 1					
17	RVS070	potentiometer	RV16A01-20-20F-A14-301	2.000	PCS	
MARK:	VR 1 3					
18	RVS071	potentiometer	RV16A01-20-20F-B13-301	1.000	PCS	
MARK:	VR 2					
19	HCSM37	MIC jack	φ6.3 stereo LJB0661-6	5.000	PCS	
MARK:	PJ 1 2 3 4 5					
20	HCSS02	DC jack	DJ-005A	1.000	PCS	
MARK:	J 1					
21	DL37RR	L.E.D high intensity	3m/m round(red) long foot	1.000	PCS	
MARK:	DL 1					
22	NI01776	LED separating pillar	LED-3 3mm	1.000	PCS	
MARK:						
23	HCSI0202	row-wire header	2P 2.5mm 180°	1.000	PCS	
MARK:	DL 2					
24	HCSP01002	row-pin(single)#1100	2.54 180° 2P(gold-plate)	1.000	PCS	
MARK:	JP 2					

Item No: aVERB

specify: AMP

Mid No: standard quantity:

NO	Material No	Item Name	Specific	Quantity	Unit	Ps
25	MMCJ04	jumper wire	6m/m	25.000	PCS	
MARK:	JP 10 11 12 13 14 16 17 18 19 20 21 22 23 24 26 3 37 42 47 48 49 50 64 70 8					
26	MMCJ06	jumper wire	8m/m	19.000	PCS	
MARK:	JP 27 28 29 30 31 32 33 34 35 36 39 4 40 41 5 6 67 7 9					
27	MMCJ09	jumper wire	10m/m	4.000	PCS	
MARK:	JP 25 43 44 45					
28	MMCJ12	jumper wire	12m/m	8.000	PCS	
MARK:	JP 46 51 52 53 54 62 68 71					
29	MMCJ14	jumper wire	15m/m	1.000	PCS	
MARK:	J 65					
30	MMCJ15	jumper wire	16m/m	11.000	PCS	
MARK:	JP 38 55 56 57 58 59 60 61 63 66 69					
31	MCOC24	filter-EMI FITER	PLT09H-2003R	1.000	PCS	
MARK:	L 10					
32	MHLT37	heat-sink	25*15*10.6-1PIN(SCL-202C	1.000	PCS	
MARK:						
33	MSCN16	Ni screw	pill 3*6 thin tooth P0.	1.000	PCS	
MARK:						
34	MFSS03	washer	φ3* φ5*1t	1.000	PCS	
MARK:						
35	STR802-T2	silicone insulator	T0-220 square type	1.000		
MARK:						
36	NMLH966ZZ	label	aVERB CKS:4172	1.000		CKS依程式内容
MARK:						

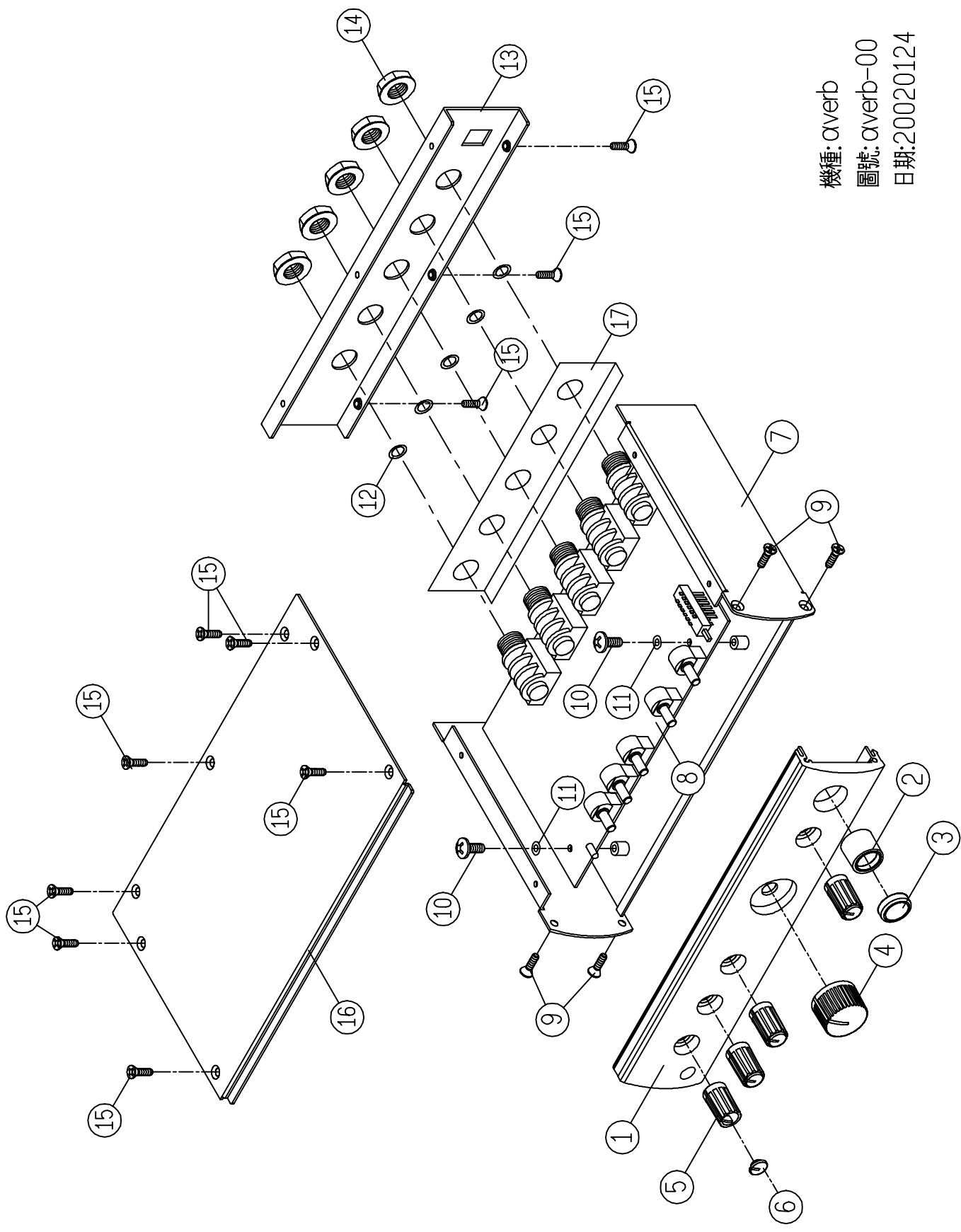

機種: averb
圖號: averb-00
日期: 20020124