

Service Manual

Model: **VERB II**

40-BIT DIGITAL EFFECTS MODULE

CONTENTS

1. INTRODUCTION

2. SPECIFICATION

3. BLOCK DIAGRAM

4. SCHEMATIC DIAGRAM

5. PCB LAYOUT

6. TEST PROCEDURE

7. BOM

8. EXPLODED VIEWS & MECHANICAL PARTS LIST

1. INTRODUCTION

- ▲ Robust and Compact Design
- ▲ 40-bit Digital Audio Processor
- ▲ 16 Great Sounding Programs
- ▲ Variation adjust knob (16 positions)
- ▲ 256 presets in total
- ▲ Analog Mix (Dry/Wet) control
- ▲ User adjustable Input and Output Gain
- ▲ Stereo/Mono Jack Inputs
- ▲ LED control for digital overdrive
- ▲ Easy to operate Front Panel controls
- ▲ SMT Design for greater reliability
- ▲ Short Signal Path and no internal cabling to provide superior sound
- ▲ Manufactured under QS9000, VDA6.1 Quality System

2. SPECIFICATION

Electrical	
Frequency Response	+0.5 / -1.5 dB from 20 Hz to 20 kHz
S/N Ratio (process)	80 dB "A" wtg, 20 Hz-22 kHz
S/N Ratio (bypass)	>90 dB "A" wtg, 20 Hz-22 kHz
THD+Noise	<0.008% @ 1 kHz (0 dBv, bypass)
Input	
Number of Channels	2
Format	1/4" unbalanced
Maximum Level (bypass)	+9 dBu
Impedance	>500 kOhms
A/D - D/A Conversions	
A/D converter	1 bit Sigma-Delta
D/A converter	1 bit Sigma-Delta
Output	
Number of Channels	2
Format	1/4" unbalanced
Maximum Level (bypass)	+9 dBu
Output Impedance	<500 Ohms
Front Panel	
Controls	IN/OUT levels (ANALOG) PROGRAM selections (2 knobs)
Indicators	Power, Signal clip LED
Rear Panel	
Input (LEFT/MONO, RIGHT)	1/4" 2-conductor (mono)
Output (LEFT, RIGHT)	1/4" 2-conductor (mono)
BYPASS	1/4" 2-conductor (auto-sense pedal type) for momentary footswitches
Power	9 Volt AC Power Adaptor
Processing and Memory	
Processor Speed	12 MIPS (million instructions per second)
Internal DSP resolution	52-bit MPY accumulator
Main Preset Programs	16
Preset Total Combinations	256
Internal digital audio memory	3000 milliseconds
Physical	
Net Weight	0.76 kg (1.26 lb)
Dimension	197(W)×131(D)×44(H)mm (7.76" × 5.12"× 1.73")

3. BLOCK DIAGRAM

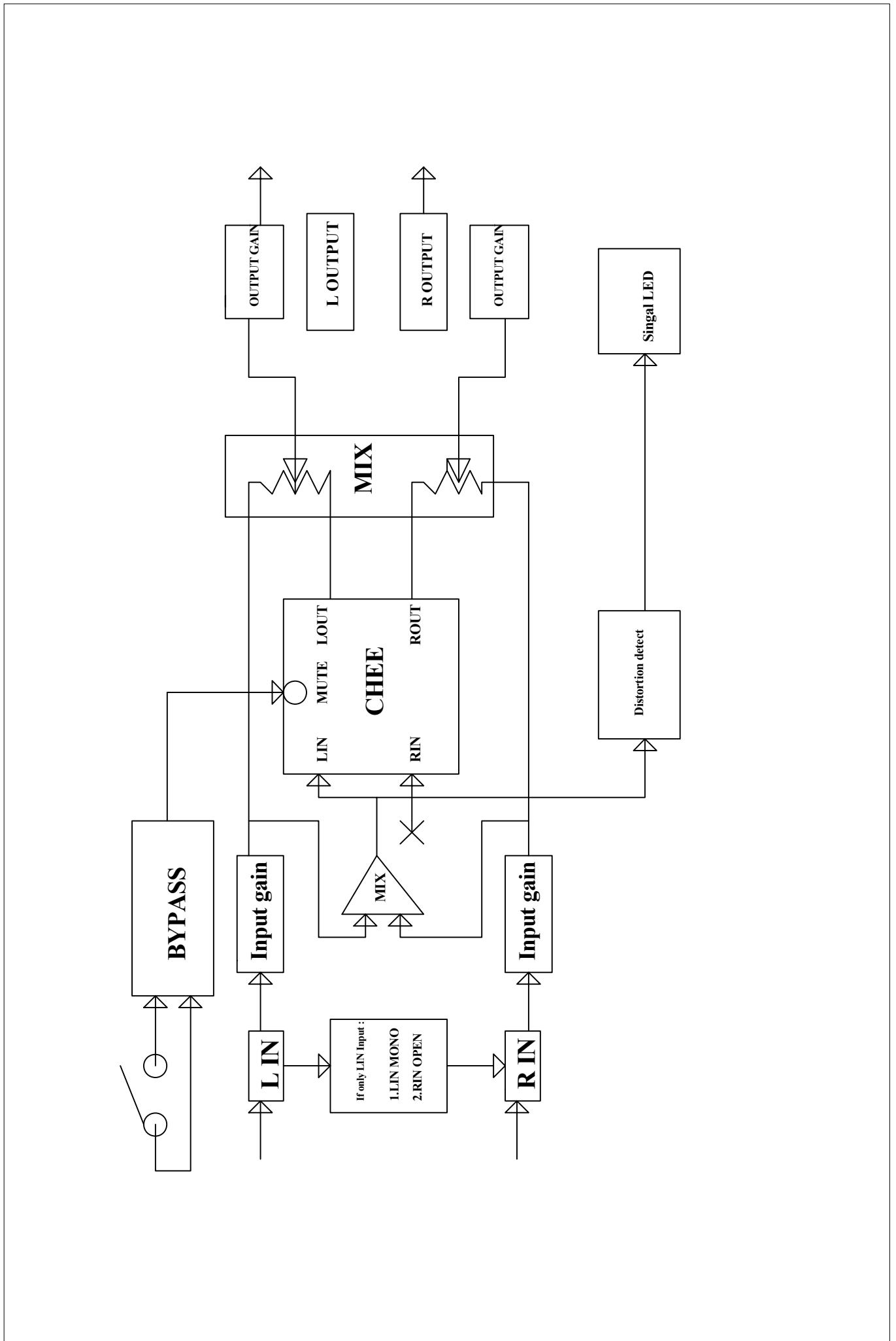

4. SCHEMATIC DIAGRAM

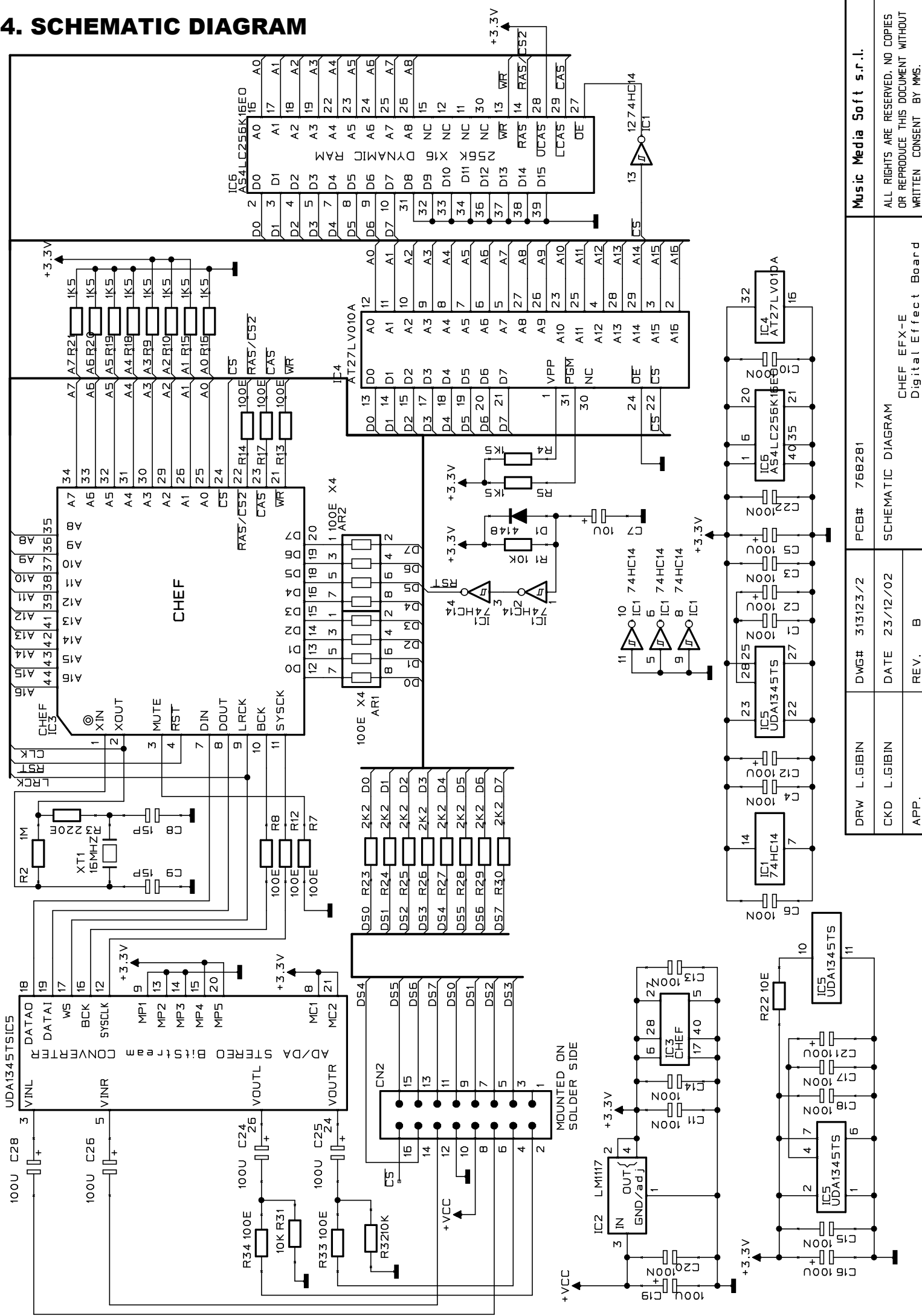

DRW L.GIBIN	DWG# 313123/2	PCB# 768281	Music Media Soft s.r.l.
CKD L.GIBIN	DATE 23/12/02	REV. B	ALL RIGHTS ARE RESERVED, NO COPIES OR REPRODUCE THIS DOCUMENT WITHOUT WRITTEN CONSENT BY MMS.
APP.			CHEF EF-E Digital Effect Board

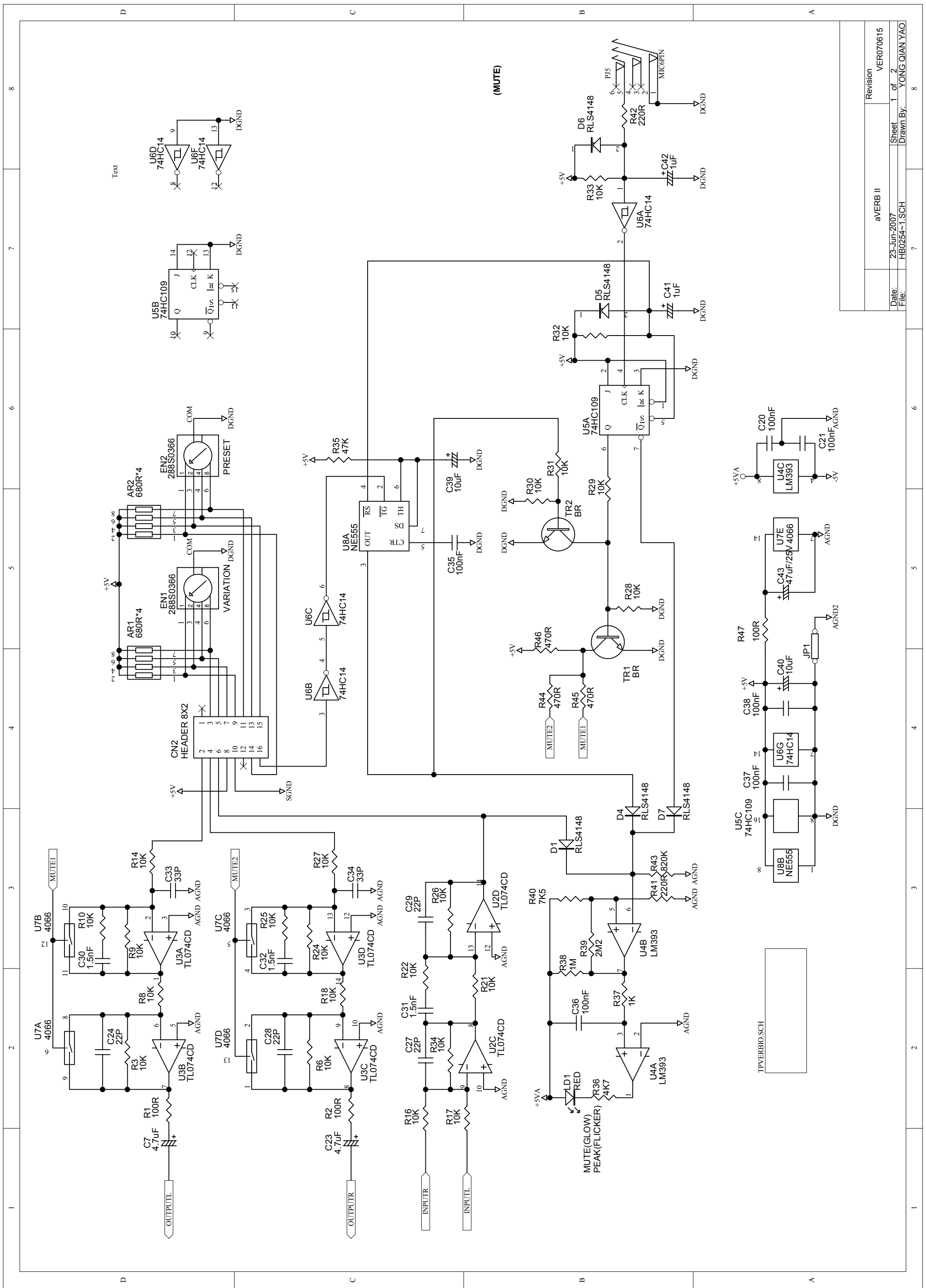

Revision	aVERB II	VER070615
Date:	23-Jun-2007	Sheet 1 of 2
File:	HB0254-1.SCH	Drawn By: YONG QIAN YAO

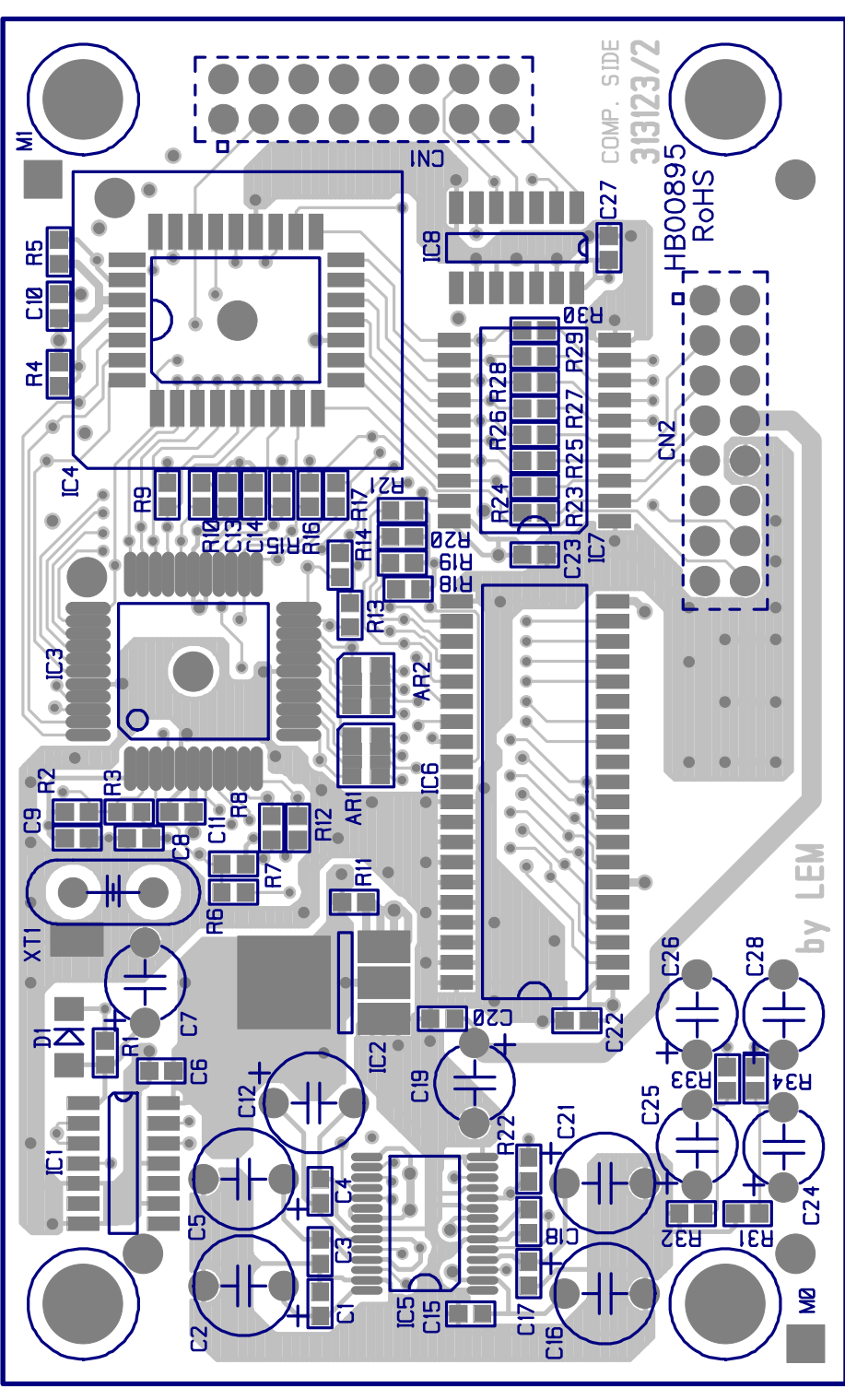
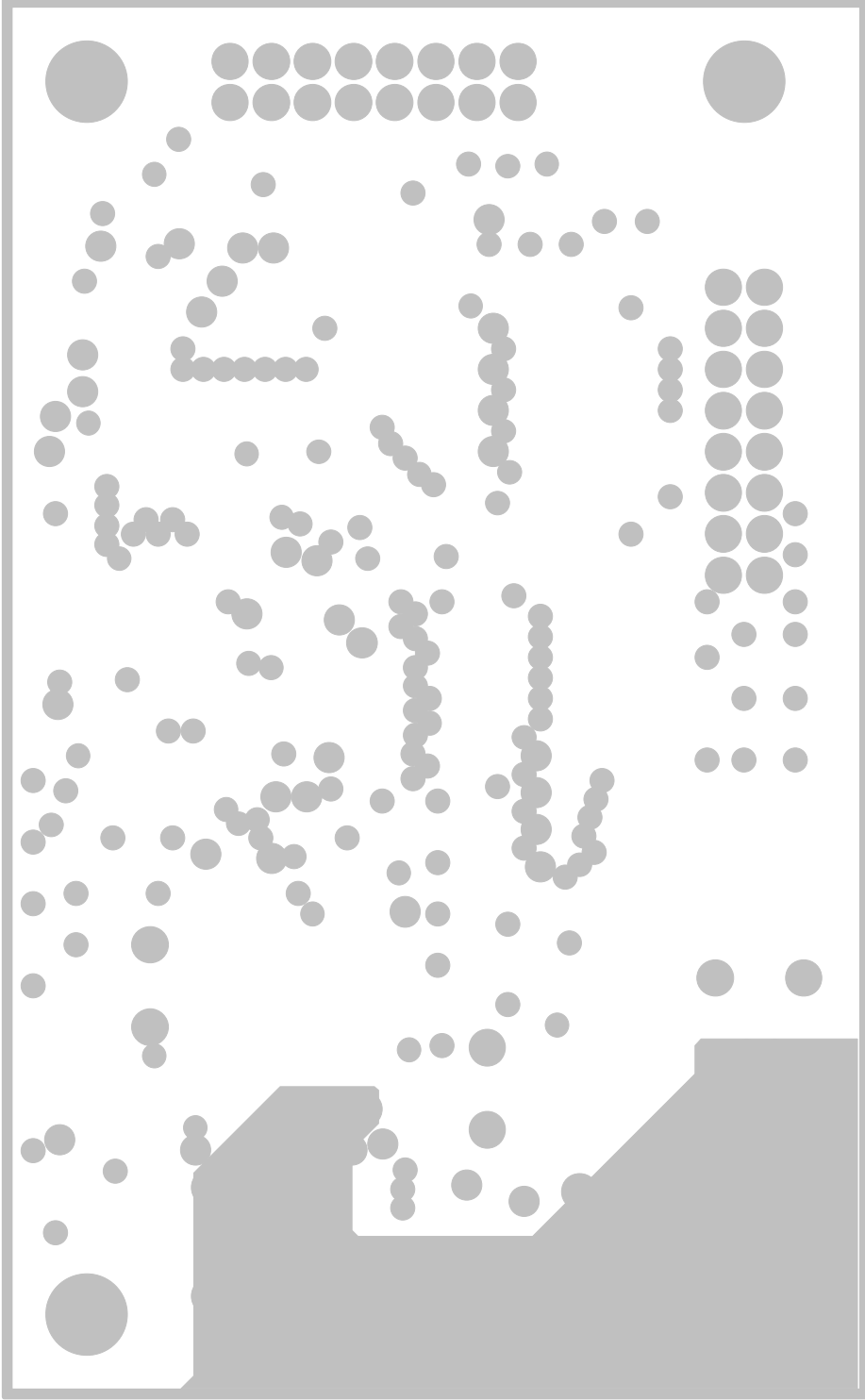
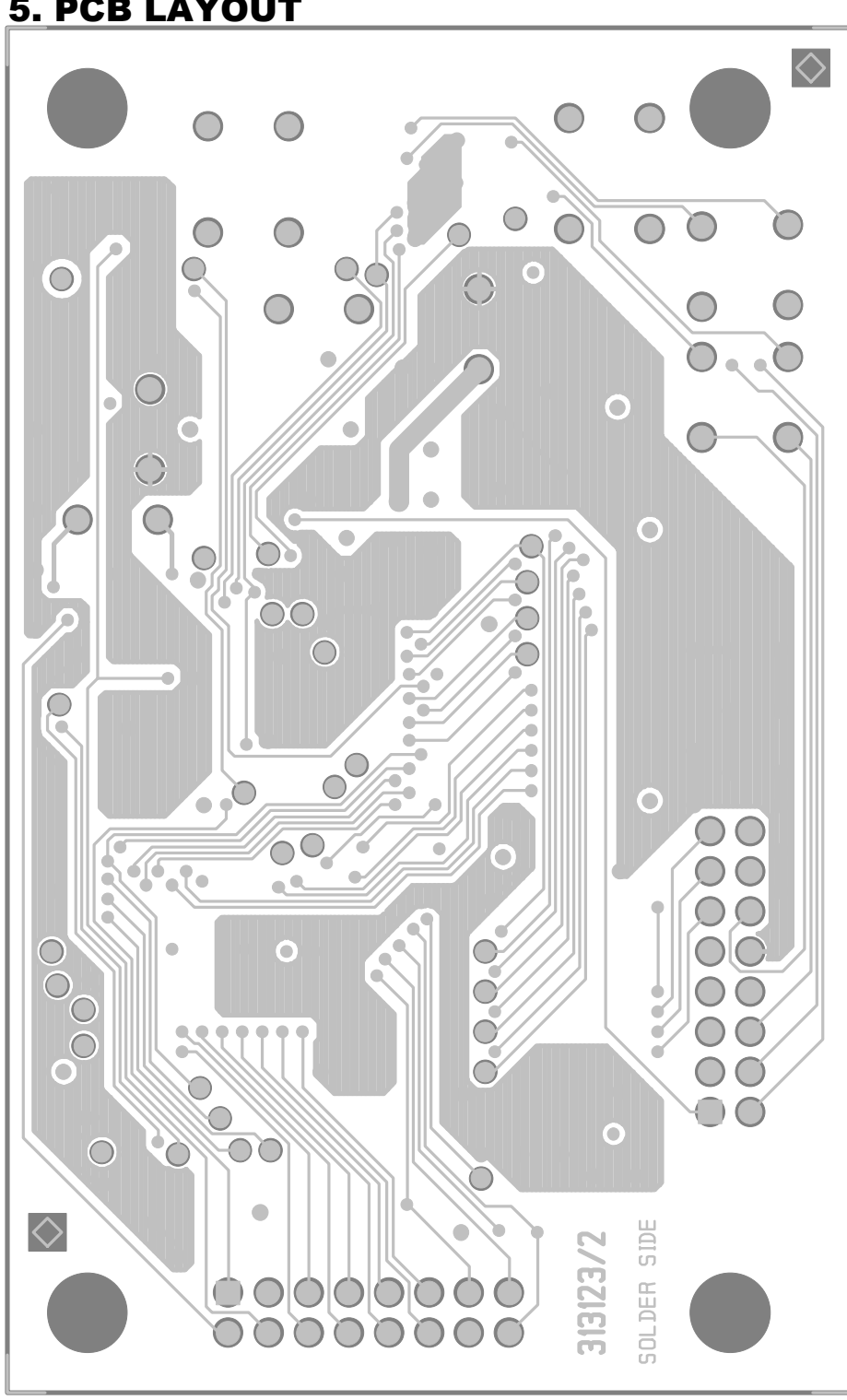
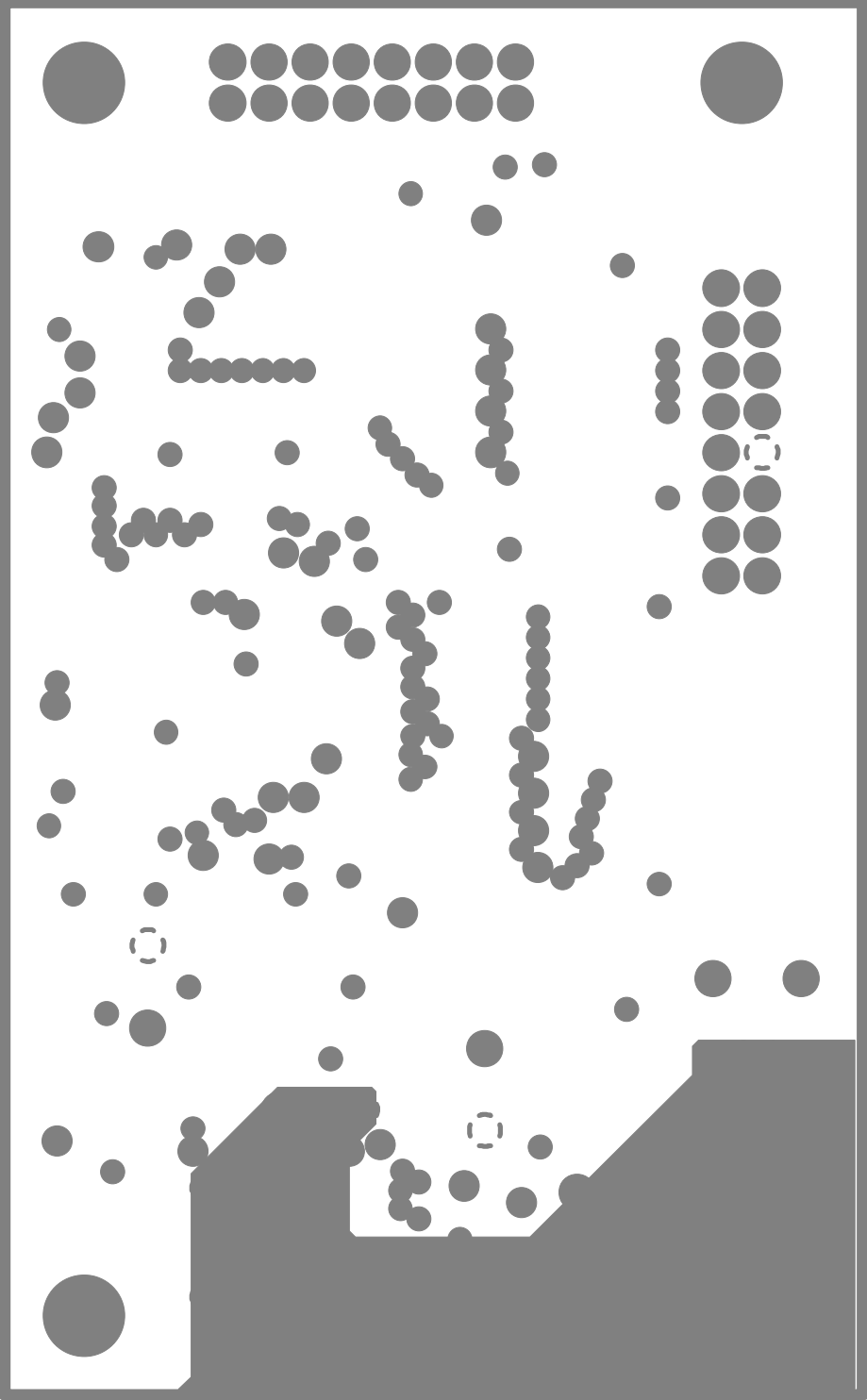

5. PCB LAYOUT

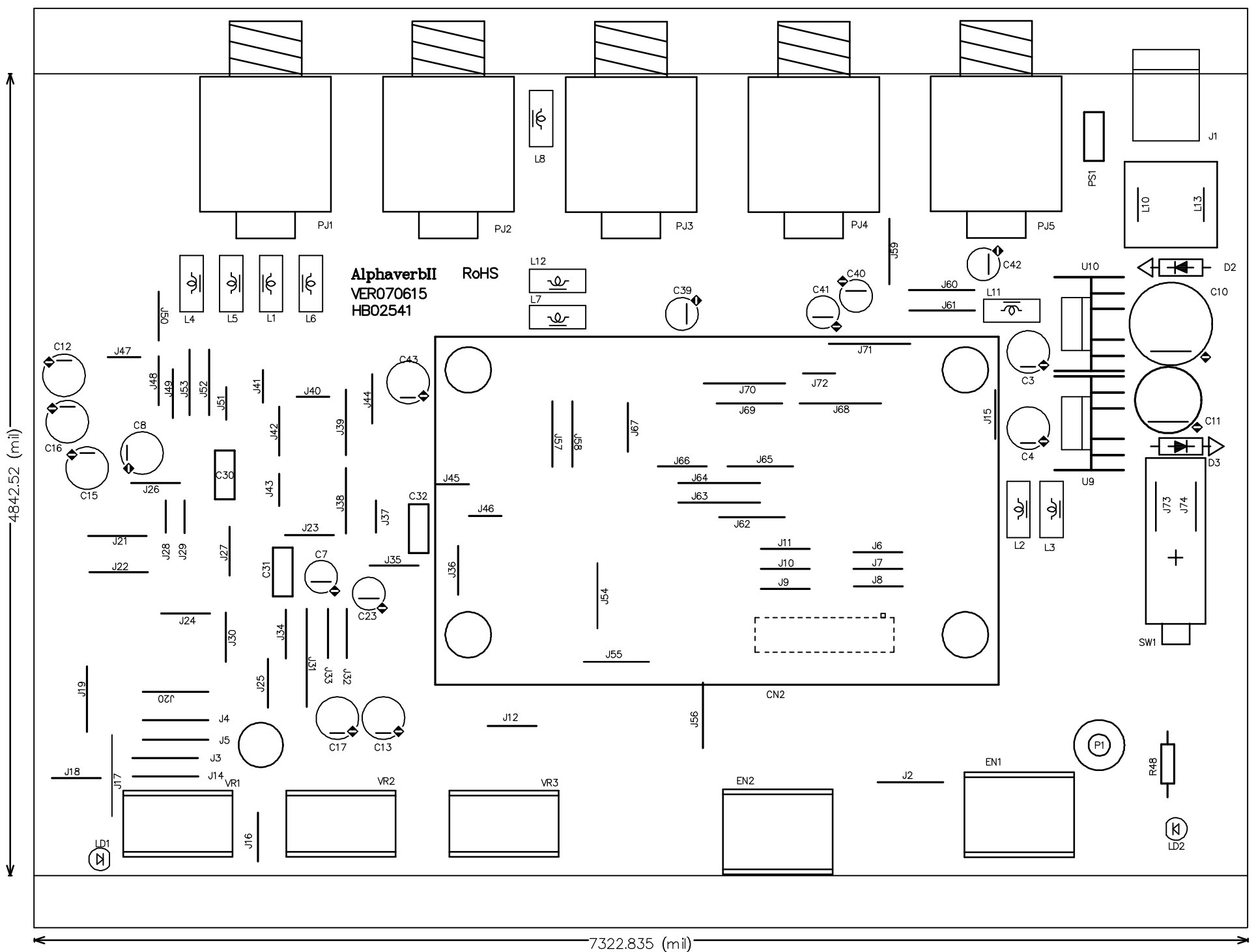
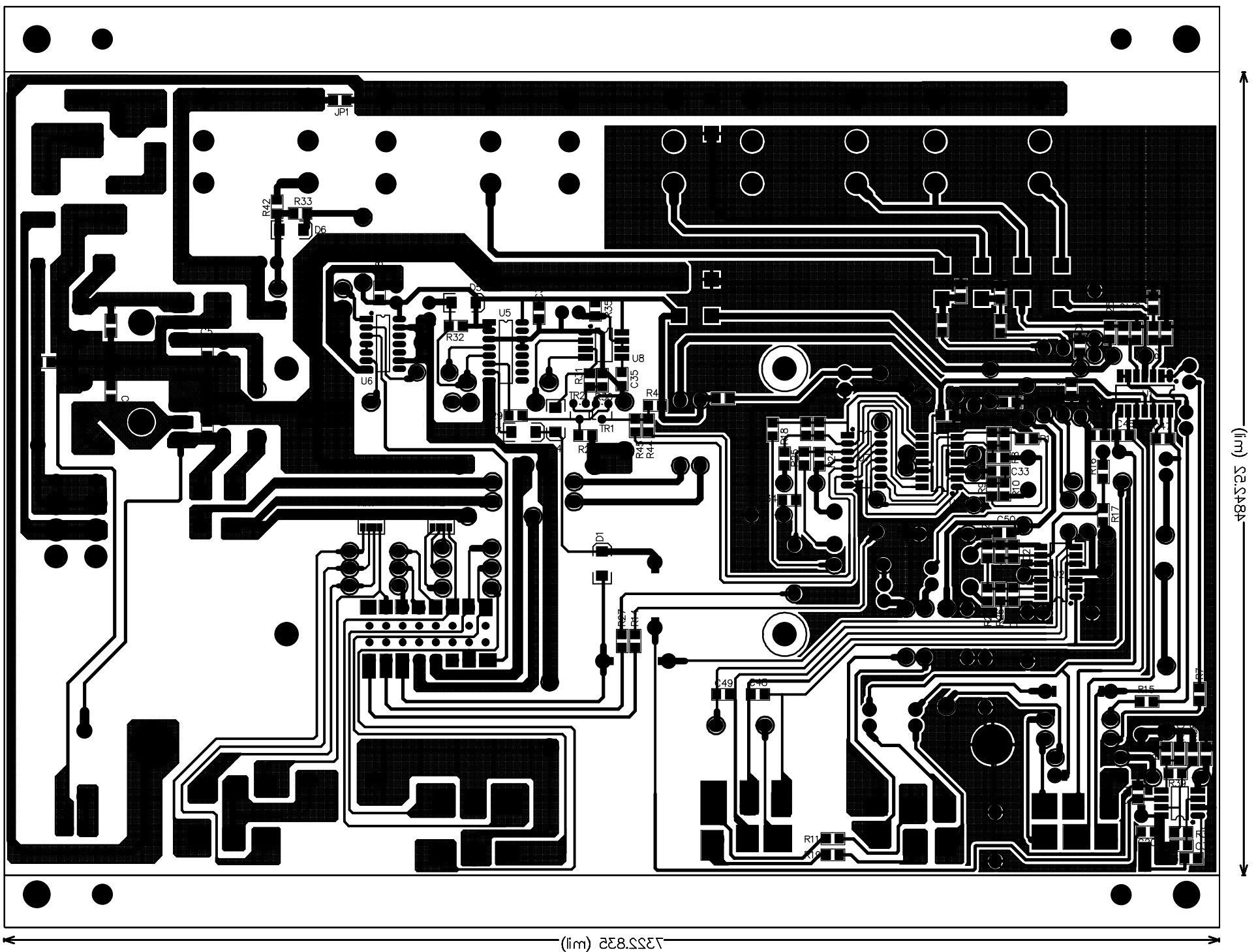

6. TEST PROCEDURE

The Finished Product Test Procedure of aVERB II

1. Test Instruments:

- a. Dual oscillograph
- b. AP (ATS-2 or System Two)
- c. AC power supply or AC/DC Adapter: 9V

2. Instruments setting:

- a. Connect the signal generator or AP output signal to L (Mono) Input (unbal-GND, 20 Ohm Z-Out), and the AP input to L, R (BNC-Unbal).
- b. BW: 22Hz 22 KHz, FLTR: A Weighting.
- c. Adjust the AP output signal to sine waveform 1 KHz, -20dbm.

3. Test Procedure:

- a. After connecting the voltage converter (9V) to the AC socket, the PWR (Red) will light up.
- b. Rotate the "VARIATIONS" (the smaller knob) to "1" position, and the "PRESETS" (the larger one) to "HALL1" position.
- c. Rotate the "INPUT", "OUTPUT" knobs to maximum, the "MIX" to minimum, the L/R output signal is -20dbm (± 2 dbm), when rotate the "INPUT", "OUTPUT" knobs to minimum, there is no output signal. (Rotate the "INPUT", "OUTPUT" knobs to maximum after the test is finished)
- d. rotate the "MIX" knob to maximum, L: -14dbm (2dbm), R: -20dbm (2dbm). During rotating this knob from minimum to maximum, the effect will be changed.
- e. The "PRESET" knob has 16 functions in this aVERB II, the testing parameter please see the below table (the "LEVEL" parameter is the reference).

No.	PRESETS	L-OUT/R-OUT LEVEL (± 2 dbm)	Note
1	HALL1	-14.0 dbm/-20 .0dbm	
2	HALL2	-11.0 dbm/-8.0 dbm	
3	HALL3	-19.0 dbm/-13.0 dbm	
4	SPRING1	-18.0 dbm/-17.0 dbm	
5	SPRING2	-18.0 dbm/-19.0 dbm	
6	TAPE	-17.0 dbm/-17.0 dbm	
7	PLATE1	-16.0 dbm/-27.0 dbm	
8	PLATE2	-17.0 dbm/-17.0 dbm	
9	TREMOLO	XXX	The signal will be changed (-17 -19 -17 dbm)
10	CHORUS	-17.0 dbm/-17.0 dbm	
11	FLANGE	XXX	The signal will be changed (-9 -26 -9 dbm)
12	DELAY	-16.0 dbm/-16.0 dbm	

No.	PRESETS	L-OUT/R-OUT LEVEL (± 2 dbm)	Note
13	DELAY/REV.	-11.0 dbm/-14.0 dbm	
14	FLANGE/REV.	XXX	The changed signal (the waveform strongly changed)
15	CHORUS/REV.	XXX	The changed signal (the waveform strongly changed)
16	ROTARY	XXX	The changed signal (the waveform strongly changed)

- f. Rotate the “VARIATIONS” (the smaller one) from “1” position, the effect will be changed (it presents the waveform will be strongly changed), and the “SIGNAL” (red) LED will blink.
- g. rotate the “MIX” knob to minimum, connect the AP output to Right Input, at this moment, only the “R” has output, rotate the “PRESET” (the larger knob) to “Delay” position, and the “VARIATIONS” (the smaller one) to “1” position, also the “MIX” knob to maximum, the sweep frequency response curve as below:

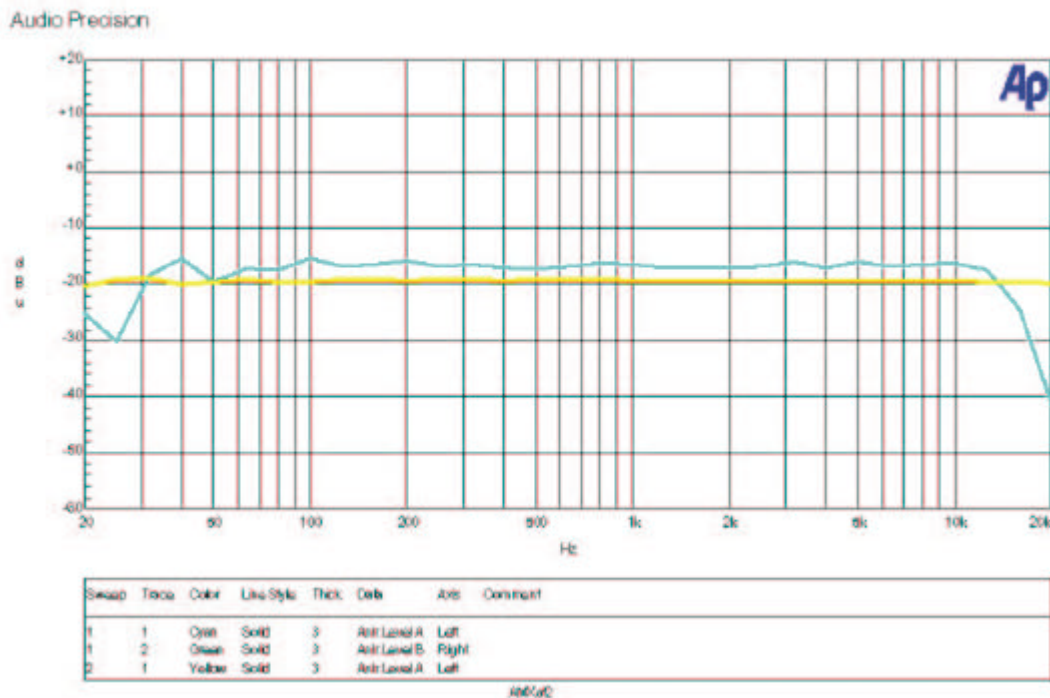

- h. Test for “BYPASS”: rotate the “MIX” to maximum, connect the footswitch to “BYPASS” jack, this footswitch can control the DSP effect.
- i. When turn off the input signal, the output noise is <-70dbm.
- j. Spot-check: to know if there is another noise and the DSP effect is OK.
- k. Factory Preset: rotate the “INPUT”, “OUTPUT”, and “MIX” knobs to minimum, the “VARIATIONS” (the smaller knob) to “1” position, and the “PRESETS” (the larger one) to “HALL1” position.

7. BOM

Rank	Part No.	Description	Specification	QTY	Remark
PF03857		DIGITAL MULTIEFFECTS	aVERB ALTO 230V CHINA	1	
0001	MA07059	panel-RS	aVERB ALTO V1.0	1	
0002	MB05584	chassis-RS	aVERB V1.0	1	
0003	MC00992	top cover-RS	aVERB V1.0	1	
0004	NI00363	knob-RS	φ21*16mm COOL GRAY 8C/072C_V1.1	1	
0005	NI02386	konb-RS	φ14*13mm	1	
0006	NI04996	knob-RS	φ11*19(5445C)_V1.0	3	
0007	NI04999	knob-RS	φ8.5*4(123U)_V1.0	2	
0008	NI04998	knob-RS	φ8.5*4(298C)_V1.0	1	
0009	MG00025	screw-RS	M3*6	6	
0010	MG00163	screw	M3*8	2	
0011	NI00002	plastic nut-RS	φ7/16**G20/15*4.8	5	
0012	MF00014	washer	φ3*φ6.5*0.5t	2	
0013	NC00131	washer	1*φ11.3*φ15.3 red	5	
0014	TG00023	adaptor	230V/50Hz_AC9V/300mA_E T-35_CE	1	
0015	HJ00002	dessicant	10g	1	
0016	NA00122	PE bag	0.04t*350*230mm	1	
0017	NA00146	bubble bag	13*16	1	
0018	NI00501	self-adhere foot cushion	12.7*9*3t(SF-004)	4	
0019	NE05006	label-RS	ALPHAVERB_V1.0	4	
0020	NE05004	label	ALTO	4	
0021	NE02717	label	MADE IN CHINA	2	
0022	NF00061	assurance card-RS-C	ALTO V1.1	1	
0023	AD00012	twin adhesive-RS	90*120mm_V1.0	1	
0024	NA00279	clip-chain bag	0.04t*100*150mm_V1.0	1	
0025	HK08950	PC board	P-aVERB -N2-DIP	1	
0001	CB00072	electrolytic capacitor	1000uF/25V φ10*20mm	1	C10
0002	HI00192	rotary switch	288S0366	2	EN1,EN2
0003	RC00086	potentiometer	A10KΩ*2 RV16A01-20-20F- A14-301	2	VR1,VR3
0004	RC00087	potentiometer	B1KΩ*2 RV16A01-20-20F- B13-301	1	VR2
0005	HC00108	stereo MIC jack	φ6.3 stereo LJB0661-6	5	PJ1,PJ2,PJ3,PJ4,PJ5
0006	HC00183	DC jack-RS	KJ-36-S φ3.5	1	J1
0007	SA00094	rectifier diode	1N4002/100V	2	D2,D3
0008	SD00074	integrated circuit	L7805CV(TO220)/(ST)	1	U10
0009	SB00083	voltage stabilized transistor-RS-ACT	UTC79L05(TO92)/(UTC)	1	U9
0010	SA00053	L.E.D	φ3 round(red)long foot	2	LD1,LD2
0011	MI00256	heat-sink	25*15*10.6-1PIN SCL-2020	1	
0012	MF00037	washer	φ3.2*φ5.5*1t	1	
0013	MG00166	screw	M3*10	1	
0014	HC00473	connector-RS	2.45mm 180° 2*8P B25- 2*8BG1(B)H=5mm	1	CN2
0015	NI02249	plastic washer	TW-1(TO-220)	1	
0016	HK08951	PC board	P-aVERB -N2-SMD	1	
0001	CI00007	SMD ceramic capacitor 0805	22PF/50V NPO	4	C24,C27,C28,C29
0002	CI00009	SMD ceramic capacitor 0805	33PF/50V NPO	2	C33,C34
0003	CI00012	SMD ceramic capacitor 0805	47PF/50V NPO	4	C46,C47,C48,C49
0004	CI00018	SMD ceramic capacitor 0805	220PF/50V NPO ±5%	2	C9,C25

Rank	Part No.	Description	Specification	QTY	Remark
0005	CI00100	SMD ceramic capacitor 0805	0.1uF/50V X7R ±10%	17	C1,C2,C5,C6,C18,C19,C20,C21,C22,C35,C36,C37,C38,C44,C45,C50,C51
0006	CI00112	SMD ceramic capacitor 0805	0.01uF/50V X7R ±10%	2	C14,C26
0007	RD00002	SMD fixed resistor 1/8W	0.0Ω ±5% 0805	1	JP1
0008	RD00006	SMD fixed resistor 1/8W	100Ω ±5% 0805	3	R1,R2,R47
0009	RD00009	SMD fixed resistor 1/8W	220Ω ±5% 0805	2	R41,R42
0010	RD00010	SMD fixed resistor 1/8W	270Ω ±5% 0805	2	R20,R23
0011	RD00014	SMD fixed resistor 1/8W	470Ω ±5% 0805	3	R44,R45,R46
0012	RD00018	SMD fixed resistor 1/8W	1.0KΩ ±5% 0805	3	R4,R12,R37
0013	RD00027	SMD fixed resistor 1/8W	4.7KΩ ±5% 0805	1	R36
0014	RD00031	SMD fixed resistor 1/8W	7.5KΩ ±5% 0805	1	R40
0015	RD00032	SMD fixed resistor 1/8W	10KΩ ±5% 0805	26	R3,R6,R7,R8,R9,R10,R11,R14,R15,R16,R17,R18,R19,R21,R22,R24,R25,R26,R27,R28,R29,R30,R31,R32,R33,R34
0016	RD00044	SMD fixed resistor 1/8W	47KΩ ±5% 0805	1	R35
0017	RD00056	SMD fixed resistor 1/8W	1.0MΩ ±5% 0805	3	R5,R13,R38
0018	RD00057	SMD fixed resistor 1/8W	2.2MΩ ±5% 0805	1	R39
0019	RD00267	SMD fixed resistor 1/8W	820KΩ ±5% 0805	1	R43
0020	RE00011	SMD resistor networks 1/16W	680Ω*4 ±5% 8P 1206(0603x4)	2	AR1,AR2
0021	SE00011	SMD rectifier diode	RLS4148 0.5A (LL-34)	5	D1,D4,D5,D6,D7
0022	SF00056	transistor	MMBT3904(SOT23)/(PHI)	2	TR1,TR2
0023	SG00001	SMD integrated circuit	TL074CDT(SO14)/(ST)	3	U1,U2,U3
0024	SG00306	SMD integrated circuit	LM393DR(TI)/(MEXICO)	1	U4
0025	SG00044	SMD integrated circuit	BU4066F(SOT73)/(PHI)	1	U7
0026	SG00068	SMD integrated circuit	74HC14DT(SO14)/(PHI)	1	U6
0027	SG00469	SMD integrated circuit	SN74HC109DR(SO16)/(TI)	1	U5
0028	AE00449	solder material without lead	9308/Sn Ag Cu	0.3768	
0029	HK08952	PC board	P-aVERB -N2-Al	1	
0001	CB00189	electrolytic capacitor	1.0uF/50V φ4*5mm	2	C41,C42
0002	CB00190	electrolytic capacitor	4.7uF/25V φ4*7mm	2	C7,C23
0003	CB00192	electrolytic capacitor	10uF/16V φ4*7mm	2	C39,C40
0004	CB00194	electrolytic capacitor	47uF/25V φ5*11mm	7	C8,C12,C13,C15,C16,C17,C43
0005	CB00195	electrolytic capacitor	100uF/16V φ6*7mm	2	C3,C4
0006	CB00251	electrolytic capacitor	220UF/25V φ8*11mm	1	C11
0007	CF00143	metal-film capacitor	0.0015uF/100V 5% CASE01	3	C30,C31,C32
0008	HA01919	jump	5mm	25	L1,L2,L3,L4,L5,L6,L7,L8,L11,L12,L10,L13,PS1,J28,J29,J37,J40,J41,J43,J45,J46,J47,J51,J72,PS1
0009	HA02441	jump	7.5mm	30	J50,J49,J48,J44,J42,J36,J35,J34,J33,J32,J30,J23,J27,J26,J25,J24,J18,J16,J15,J12,J11,J10,J9,J8,J7,J6,J66,J67,J73,J74
0010	HA01925	jump	10mm	22	J62,J61,J60,J59,J58,J57,J56,J55,J54,J53,J52,J39,J38,J20,J19,J14,J5,J4,J3,J2,J65,J69
0011	HA01935	jump	12.5mm	6	J63,J64,J68,J70,J71,J17
0012	HA01924	jump	9mm	2	J21,J22

Rank	Part No.	Description	Specification	QTY	Remark
0013	HA01930	jump	15mm	1	J31
0014	HB02541	PCB-RS	Alphaverb VER070615	1	
0030	SG00243	SMD integrated circuit	NE555DR(SO8)/(TI)	1	U8
0017	AC00179	tin without lead-RS	M705E Sn 3Ag-0.5Cu	8.6	
0018	NI01776	LED spacer support	LED-3 3mm	2	
0019	ME00015	color nut	3m/m	4	
0020	MG00036	screw	M3*4	4	
0021	MG00284	copper pillar	M3*8*0.5PH	4	
0022	HK04336	PC board	P-313123-DIP(TOPVerb)	1	
0001	SC00004	crystal oscillator	16.00MHZ	1	XT
0002	HC00512	connector	2.54 180°2*8P(gold-plated) 4/9.5mm	1	CN2
0003	SG00300	SMD integrated circuit	SST39VF010-70n/TOPVerb	1	IC4
0004	NE13363	label	TOPVerb V1.0	1	
0005	HK03894	PC board-RS-ACT	P-313123-SMD(L-8)	1	
0001	HB00895	PCB	313123/2(1*6)	1	
0002	CI00075	SMD ceramic capacitor 0603	0.1uF/50V Y5V +80,-20%	13	C17,C15,C18,C6,C10, C22,C20,C13,C14,C1, C3,C4,C11
0003	RD00061	SMD fixed resistor	10Ω ±5% 0603	1	R22
0004	RD00068	SMD fixed resistor 1/10W	100Ω ±5% 0603	8	R12,R14,R7,R8,R34, R17,R13,R33
0005	RD00073	SMD fixed resistor	220Ω ±5% 0603	1	R3
0006	RD00085	SMD fixed resistor 1/10W	1.5KΩ ±5% 0603	10	R16,R15,R21,R20,R4, R19,R10,R18,R9,R5
0007	RD00088	SMD fixed resistor 1/10W	2.2KΩ ±5% 0603	8	R28,R27,R23,R24, R29,R30,R25,R26
0008	RD00101	SMD fixed resistor	10KΩ ±5% 0603	3	R32,R31,R1
0009	RD00125	SMD fixed resistor	1.0MΩ ±5% 0603	1	R2
0010	RE00006	SMD resistor networks 1/16W	100KΩ*4 ±5% 8P 1206(0603x4)	2	AR1,AR2
0011	SE00011	SMD rectifier diode	RLS4148 0.5A (LL-34)	1	D1
0012	SG00068	SMD integrated circuit	74HC14DT(SO14)/(PHI)	1	IC1
0013	SG00410	SMD integrated circuit- RS-ACT	IC41LV16256- 35KG(SOJ40)/(ICSI)	1	IC6
0014	SG00166	SMD integrated circuit	TY-2	1	IC3
0015	SG00037	SMD integrated circuit	LD1117DT33C(TO252)/(ST)	1	IC2
0016	HC00611	IC socket (SMD)	PLCC32 (AMP S/N:822516-	1	IC4
0017	SG00016	SMD integrated circuit	UDA1345TS(SSOP28)/(PHI)	1	IC5
0018	AE00449	solder material without lead	9308/Sn Ag Cu	0.3864	
0019	CI00264	SMD ceramic capacitor- RS 0603	15PF/50V NPO ±5	2	C8,C9
0006	AC00179	tin without lead-RS	M705E Sn 3Ag-0.5Cu	5.058	
0007	CB00166	electrolytic capacitor	100uF/16V φ6*5mm	11	C19,C12,C5,C2, C24,C16,C21,C25, C26,C28,C7
0023	RA01234	fixed resistor 1/4W	4.7KΩ	1	R48
0026	NB02141	carton	a VERB;a COMP;a MICTUBE ALTO	1	
0027	NB05581	inner case-RS	αVERB ALTO V1.0	1	
0028	MG00538	screw	M3*10*0.5PH V1.0	4	
0029	NF02910	user manual-RS	αVERB ALTO V1.0	1	
0030	NE05847	label-RS-ACT	aVERB II V1.0	1	

8. EXPLODED VIEWS & MECHANICAL PARTS LIST

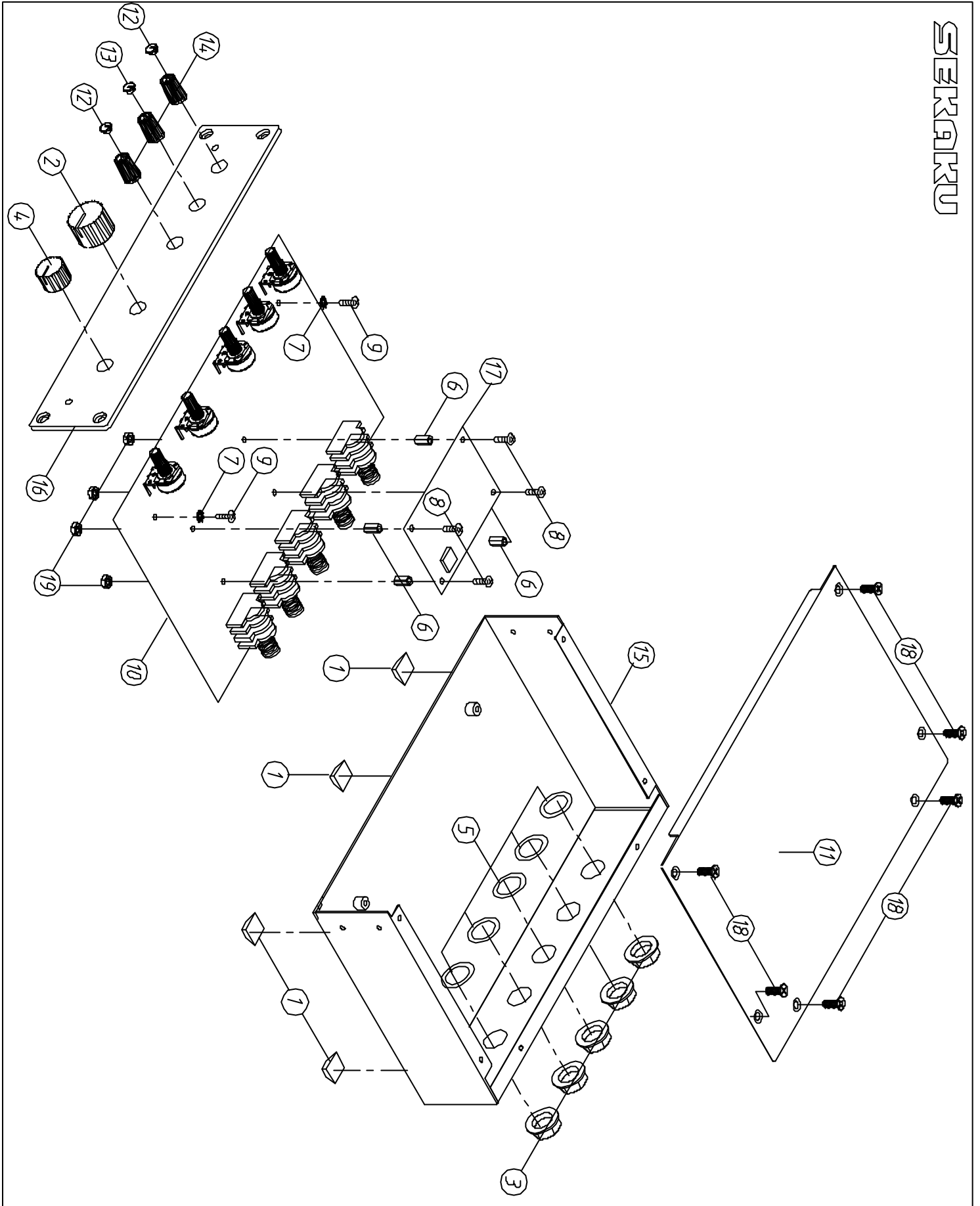

MECHANICAL PARTS LIST

No.	Part No.	Description	Specification	QTY
1	NI00501	self-adhesive foot cushion-RS	12.7*9*3t (SF-004)	4
2	NI00363	plastic knob-RS-C	φ21*16mm COOL GRAY 8C 072C	1
3	NI00002	plastic nut-RS	φ7/16"*G20/15*4.8	5
4	NI02386	plastic knob-RS-C	φ14*13mm (cool gray 8C 072C)	1
5	NC00131	T-washer-RS-ACT	1*φ11.3*φ15.3 red	5
6	MG0028	copper pillar-RS	M3*8*0.5PH 14	4
7	MF00014	washer-RS-ACT-zinc plated	φ3*φ6.5*0.5t	2
8	MG0003	screw-RS	M3*4	4
9	MG0016	nickle screw-RS	M3*8	2
10	HK04336	K-PCB	313123-DIP(TOPVerb)	1
11	MC0099	ZB-top cover-RS-5252	aVERB _V1.0	1
12	NI04999	knob-RS-CT-ABS	φ8.5*4(123U yellow) _V1.0	2
13	NI04998	knob-RS-CT-ABS	φ8.5*4(298C blue) _V1.0	1
14	NI04996	plastic knob-RS-CT-	φ11*19(5445C gray) _V1.0	3
15	MB05584	ZC-chassis-RS-	αVERB _V1.0	1
16	MA07059	ZC-front panel-RS-5063 blue	αVERB ALTO _V1.0	1
17	HK08950	K-PCB	aVERB -N2-DIP	1
18	MG0002	screw-RS	M3*6	6
19	ME00015	color nut-RS	3mm	4