

Service Manual

Model: ALTODRIVE2.3

2-WAY STEREO DIGITAL X - OVER



www.altoproaudio.com

Version: 1.1

CONTENTS

1. Specification.....	1
2. Block Diagram.....	0
3. Schematic Diagram... ..	9
4. Printed Circuit Board.....	19
5. Wiring Diagram.....	1
6. Test Procedure.....	0
7. Electrical Parts List.....	16
8. Exploded Views & Mechanical Parts List.....	1
9. Troubleshooting.....	0
10. Notes.....	0

Input Channel

Digital Input Gain

- /+ 12 dB / step 0.5 dB

4 Parametric Filters

Gain - /+ 15 dB / step 0.5 dB

Freq 20 Hz - 20 KHz step 1/12 oct

BandWidth 0.05 oct - 3 oct / step 0.05 oct

Delay line

Up to 512 ms minimum step 21us

Output Channel

Digital Out Volume

- /+ 12 dB / step 0.5 dB

Delay line

Up to 512 ms minimum step 21us

5 Parametric Filters

Gain - /+ 15 dB / step 0.5dB

Freq 20 Hz - 20 KHz / step 1/12 oct

BandWidth 0.05 oct - 3 oct step 0.05 oct

High Pass Filter Type Butterworth

Freq: 20 Hz - 20 KHz / step 1/12 oct

Slope: Bypass, 1stord, 2ndord, 3rdord, 4thord

Low Pass Filter Type Butterworth

Freq: 20 Hz - 20 KHz / step 1/12 oct

Slope: Bypass, 1stord, 2ndord, 3rdord, 4thord

Polarity

Phase 0° or 180°

Limiter

Threshold - 29 dB up to 0 dB / step 1dB

Release Time 0.4 s, 0.5 s, 0.7 s, 1.4 s

Attack Time 0.05 s, 0.10 s, 0.20 s, 0.30 s

The Whole Unit

Memory

1 Factory Preset

64 User Preset

Analog

Inputs

2 XLR - F (BAL)

Outputs

4 XLR - M (BAL)

Input Impedance

>40kΩ

Output Impedance

<200Ω

Input MAX Level

12dBv

Output MAX Level

12dBv

A/D Converter

20BITS Sigma-Delta

D/A Converter

24BITS Sigma-Delta

Performance

THD+N

0.02%(1KHz - 3dBFS)

Amplitude Response

20Hz - 20KHz

S/N Ratio

>97dBa

Digital

Processor speed

36 MIPS

DSP resolution

24×32 bits

Control

Microprocessor

MIDI section

Connections

Input/output/thru

Sockets

5 - poles DIN(female)

Mode

Photocoupled

Power Supply

Connector type	3 - poles DIN (female)
Type	Servo controlled, Switching
Fuse	210 - 240V: T250mAL250VAC 95 - 120V: 500mAL250VAC
AC input	95 - 240V~60 - 50Hz
Rated power consumption	15W

User Interface

Graphic display	128×64 dots
Keyboard	6 LEDs/12user's keys
Vu meter	2×6 LEDs

Physical

Size	Standard 19"rack Mounting
Dimensions	483(W)×232.5(D)×44(H)mm(19"×9.3"×1.7")
weight	3.5Kg(7.72lb)

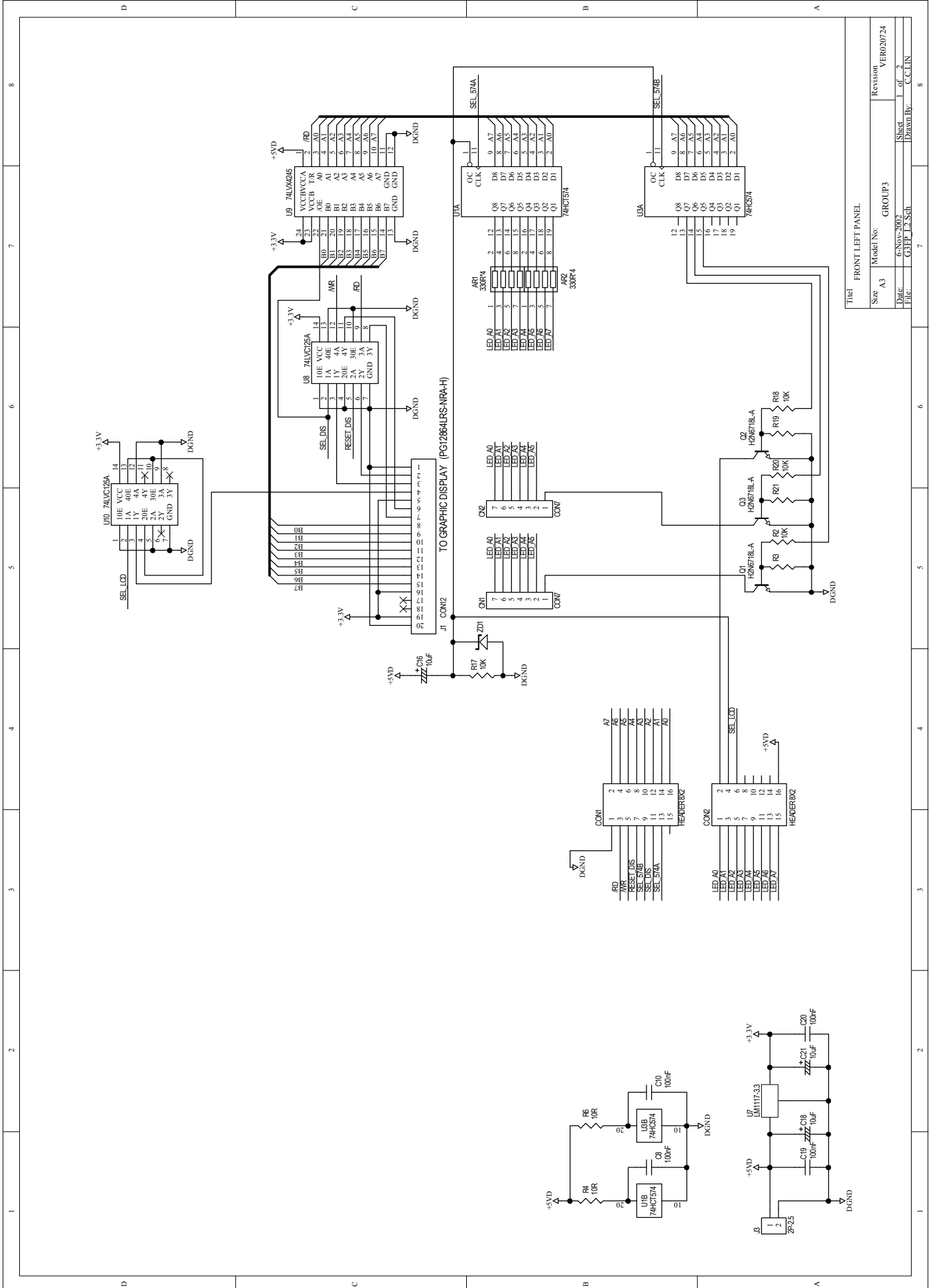

FRONT LEFT PANEL

Model No:	GROUP3	Revision	VER020724
Size	A3	Sheet	of 2
Date:	6/25/2007	Drawn By:	C.C.LIN
File:	CEP12A.Sch		

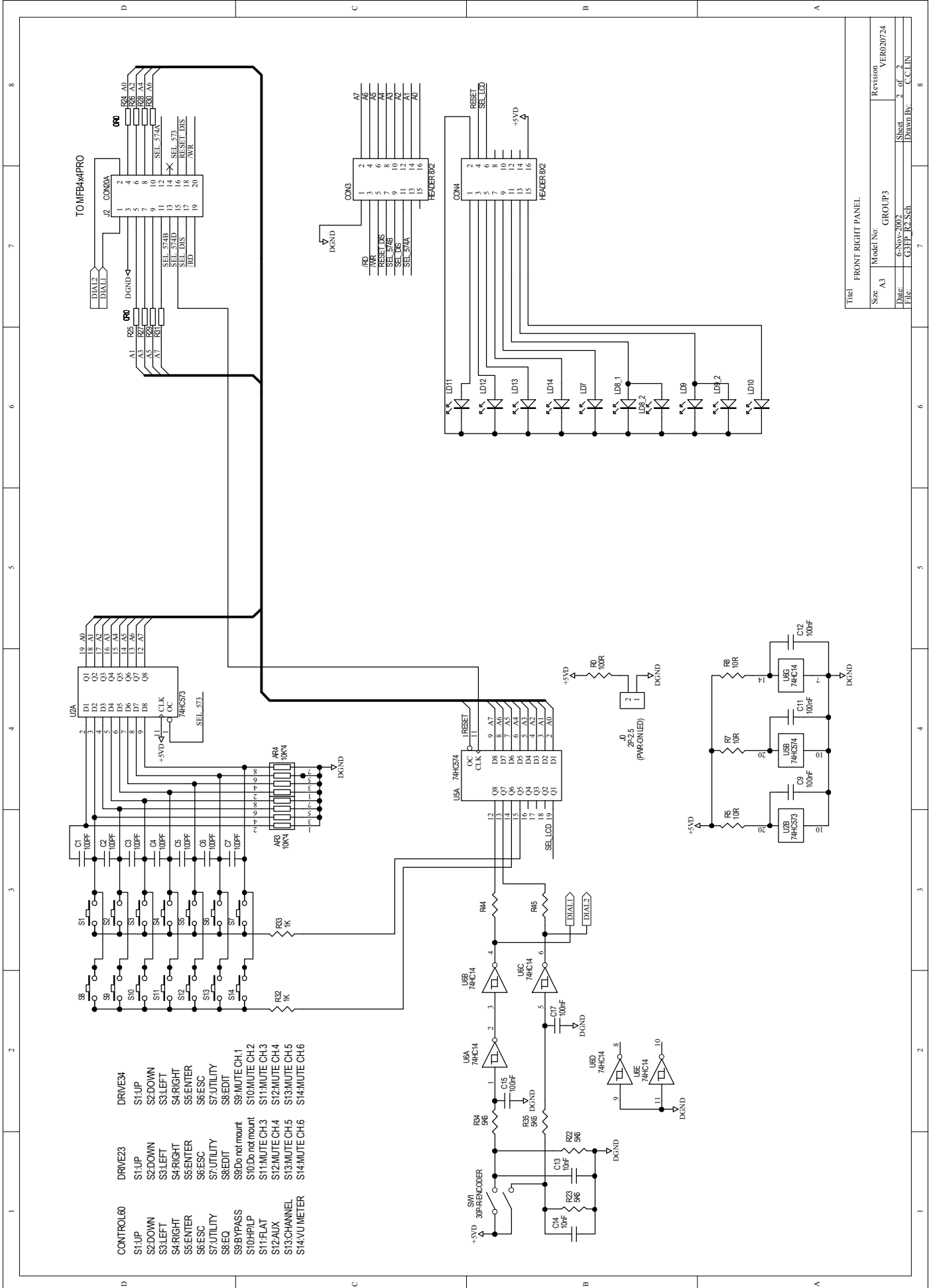

- CONTROL60**
- S1:UP
 - S2:DOWN
 - S3:LEFT
 - S4:RIGHT
 - S5:ENTER
 - S6:ESC
 - S7:UTILITY
 - S8:EQ
 - S9:PASS
 - S10:PLP
 - S11:FLAT
 - S12:AUX
 - S13:CHANNEL
 - S14:METER
- DRIVE23**
- S1:UP
 - S2:DOWN
 - S3:LEFT
 - S4:RIGHT
 - S5:ENTER
 - S6:ESC
 - S7:UTILITY
 - S8:EDIT
 - S9:MUTE CH.1
 - S10:MUTE CH.2
 - S11:MUTE CH.3
 - S12:MUTE CH.4
 - S13:MUTE CH.5
 - S14:MUTE CH.6
- DRIVE34**
- S1:UP
 - S2:DOWN
 - S3:LEFT
 - S4:RIGHT
 - S5:ENTER
 - S6:ESC
 - S7:UTILITY
 - S8:EDIT
 - S9:MUTE CH.1
 - S10:MUTE CH.2
 - S11:MUTE CH.3
 - S12:MUTE CH.4
 - S13:MUTE CH.5
 - S14:MUTE CH.6

Title		FRONT RIGHT PANEL	
Size	A3	Model No.	GROUP3
Date	6/15/2002	Revision	VER020724
File	CEFP-RA-Sub	Sheet	2 of 2
		Drawn By	C.C.LIN

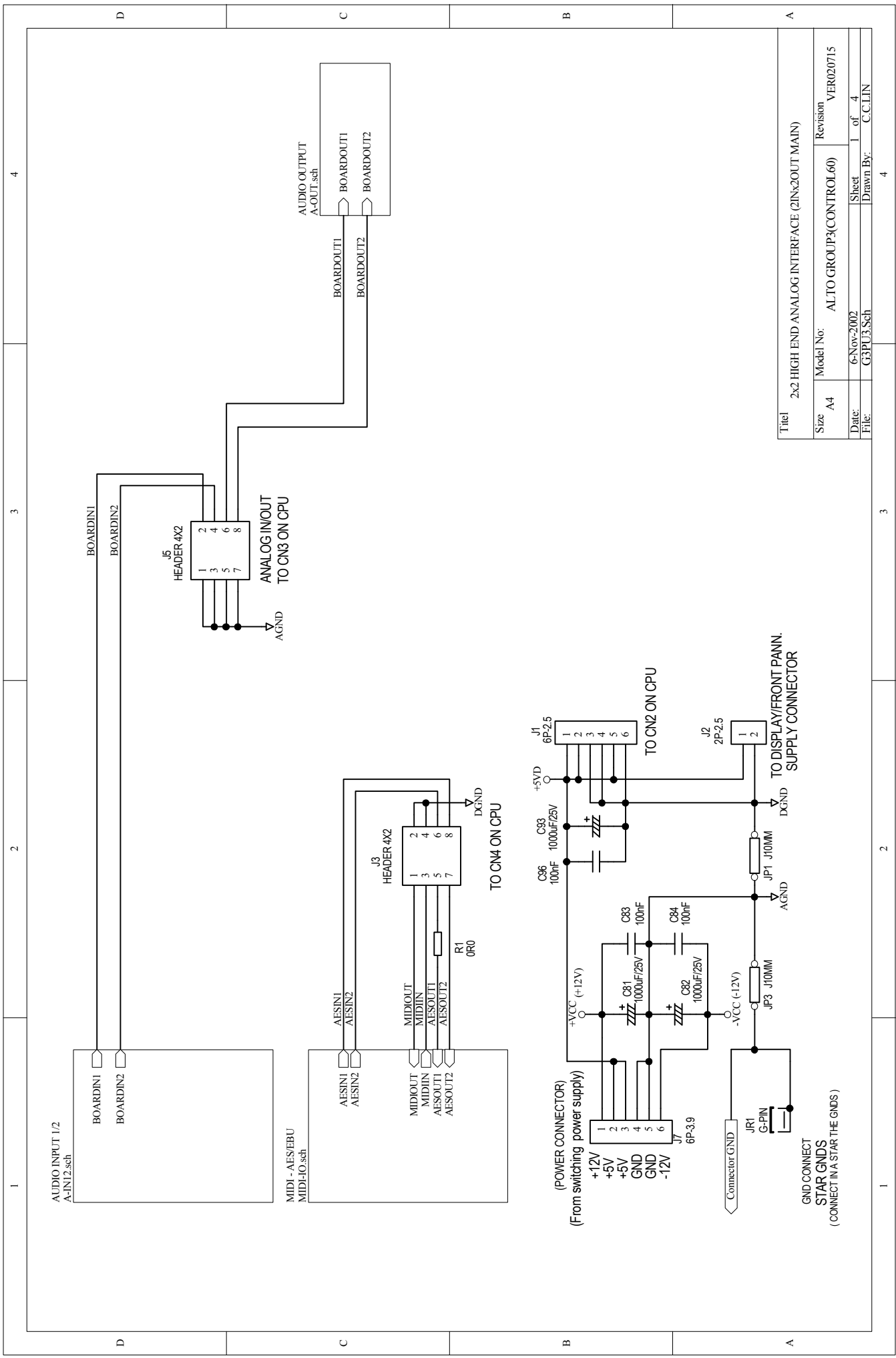

Title		2x2 HIGH END ANALOG INTERFACE (2INx2OUT MAIN)	
Size	A4	Model No:	ALTO GROUP3(CONTROL60)
Date:	6-Nov-2002	Revision	VER020715
File:	G3PU3.Sch	Sheet	1 of 4
		Drawn By:	C.CLIN

GND CONNECT
STAR GND'S
(CONNECT IN A STAR THE GND'S)

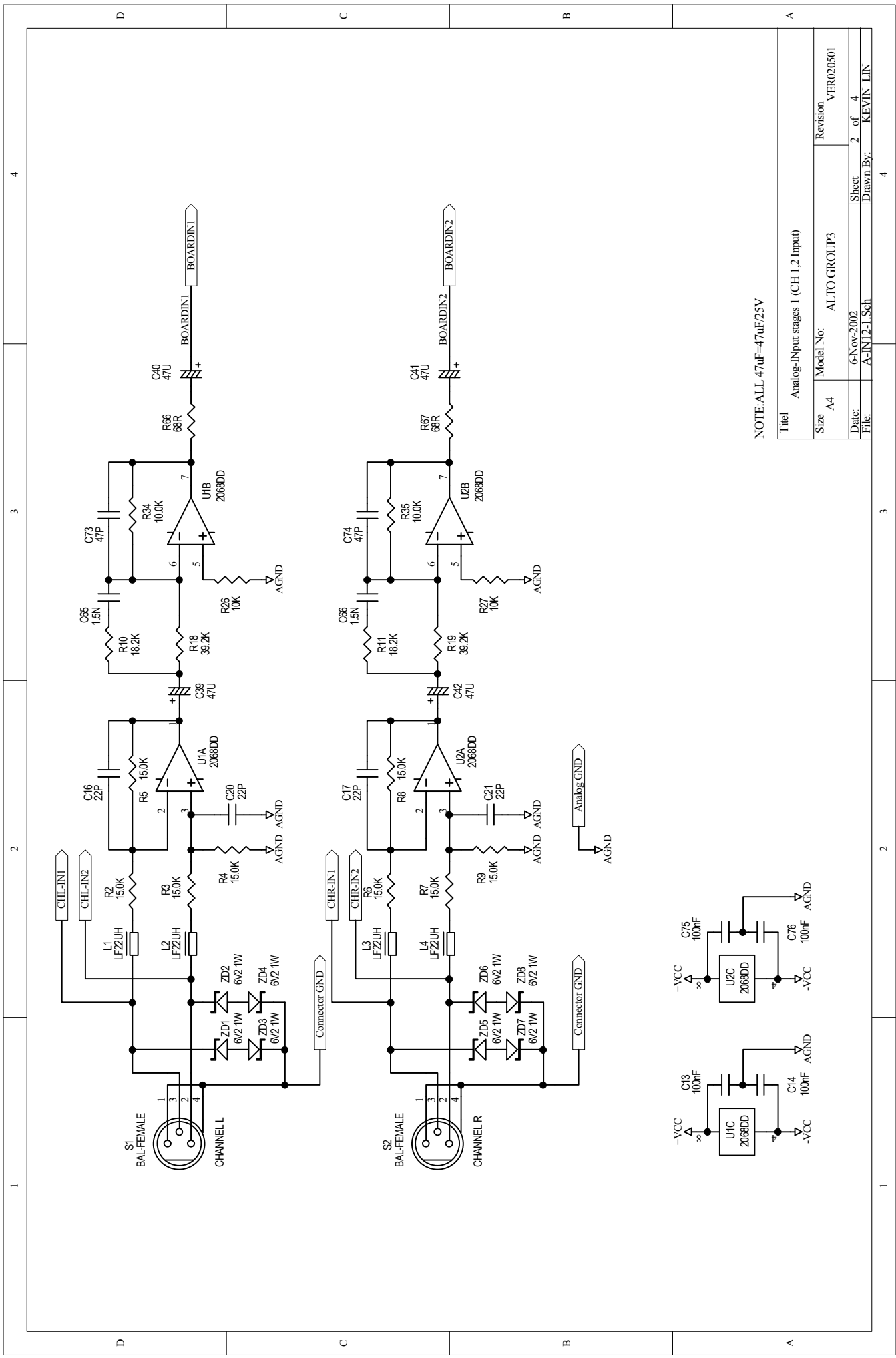

NOTE: ALL 47uF=47uF/25V

Title		Analog-Input stages 1 (CH 1,2 Input)	
Size	A4	Model No:	ALTO GROUP3
Date:	6-Nov-2002	Revision	VER020501
File:	A-IN12-1.Sch	Sheet	2 of 4
		Drawn By:	KEVIN LIN

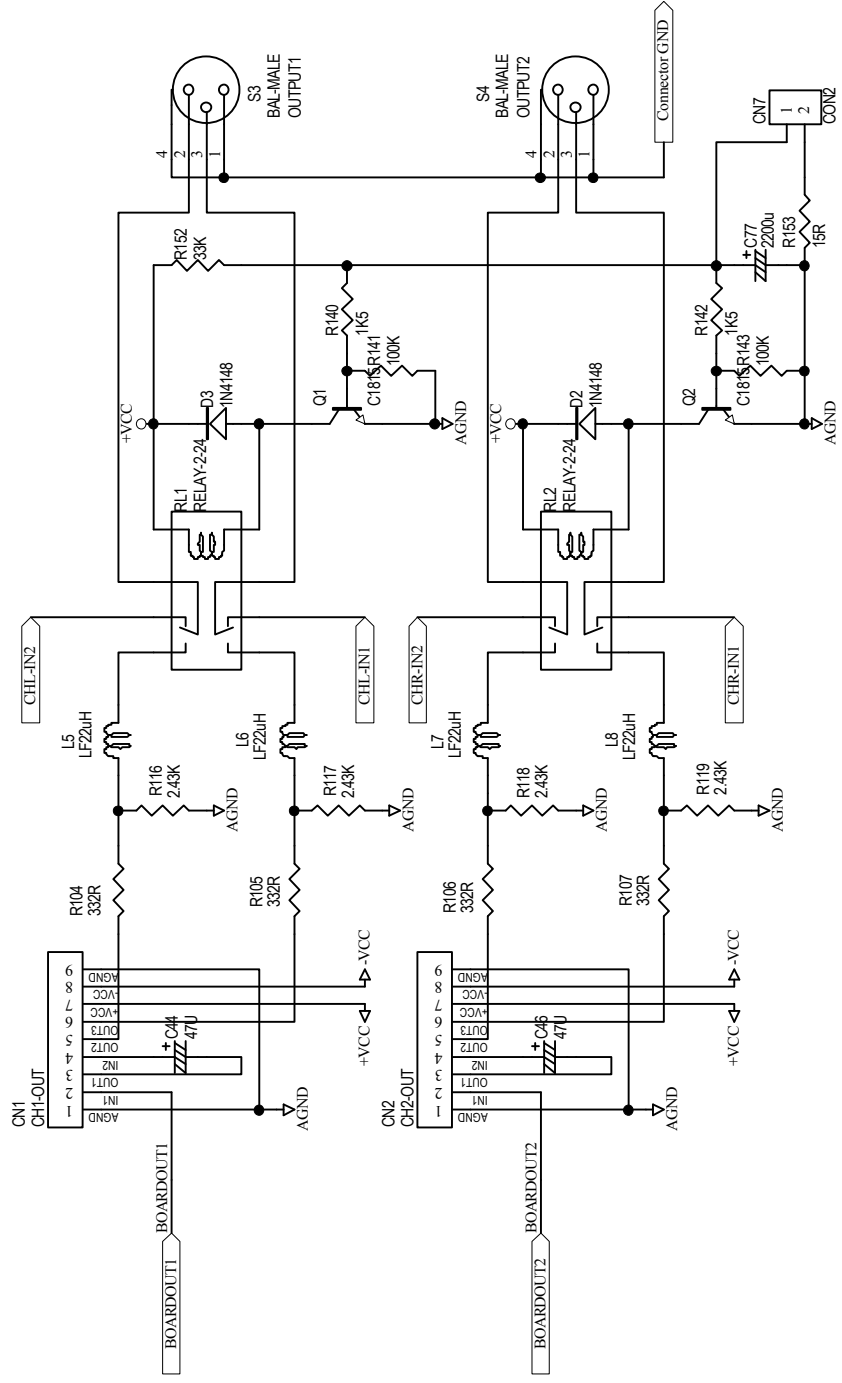

Title		Analog-Output	
Size	A4	Model No:	ALTO GROUP3(CONTROL60)
Date:	6-Nov-2002	Revision	VER020715
File:	A-OUT1.Sch	Sheet	3 of 4
		Drawn By:	C.CLIN

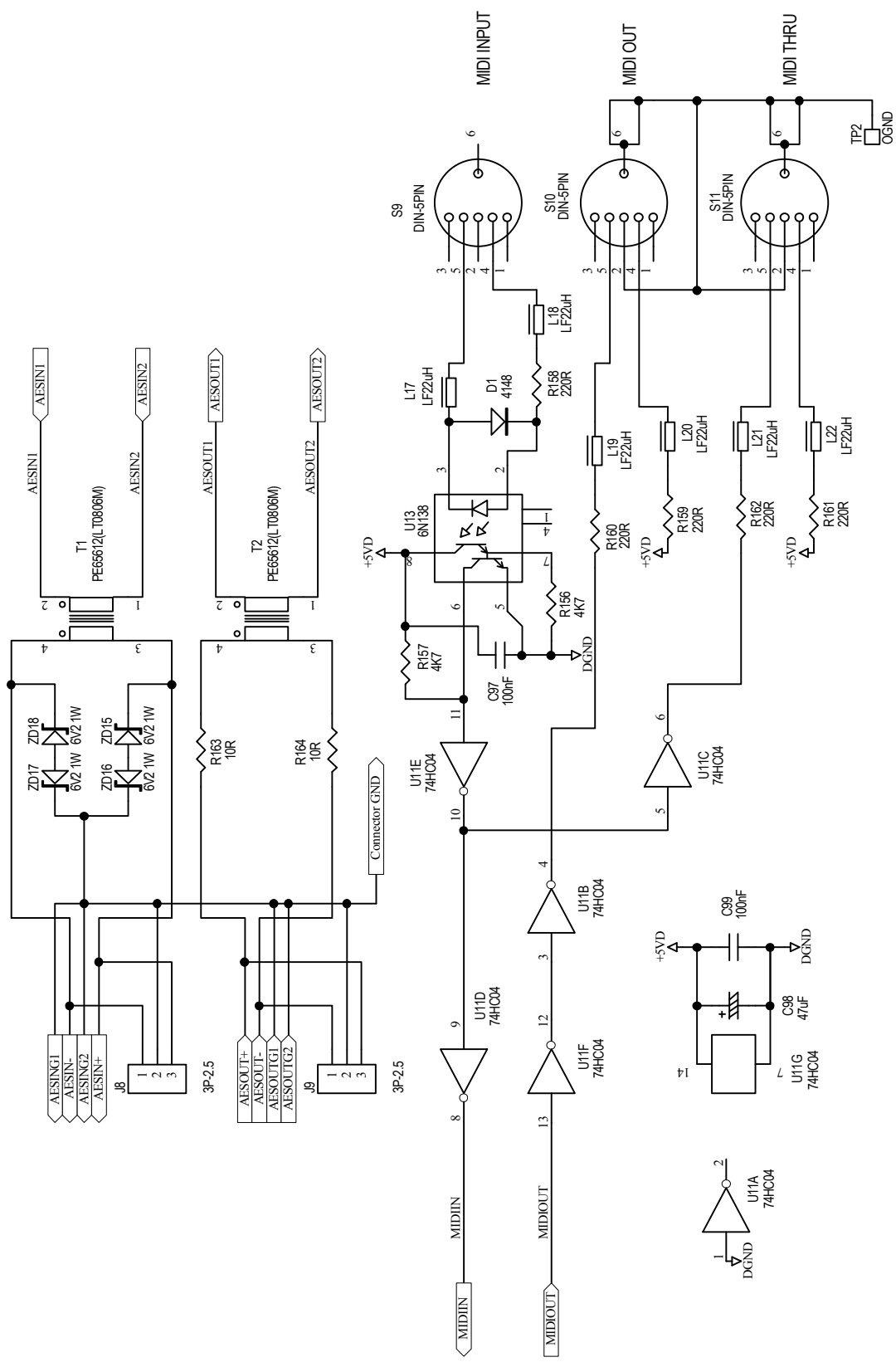

Title: MIDI IN-OUT & AES/EBU DIGITAL STAGE

Size: A4	Model No: ALTO GROUP(CONTROL60)	Revision: VER020715
Date: 6-Nov-2002	Sheet: 4 of 4	
File: MIDI-I/O.Sch	Drawn By: C.C.LIN	

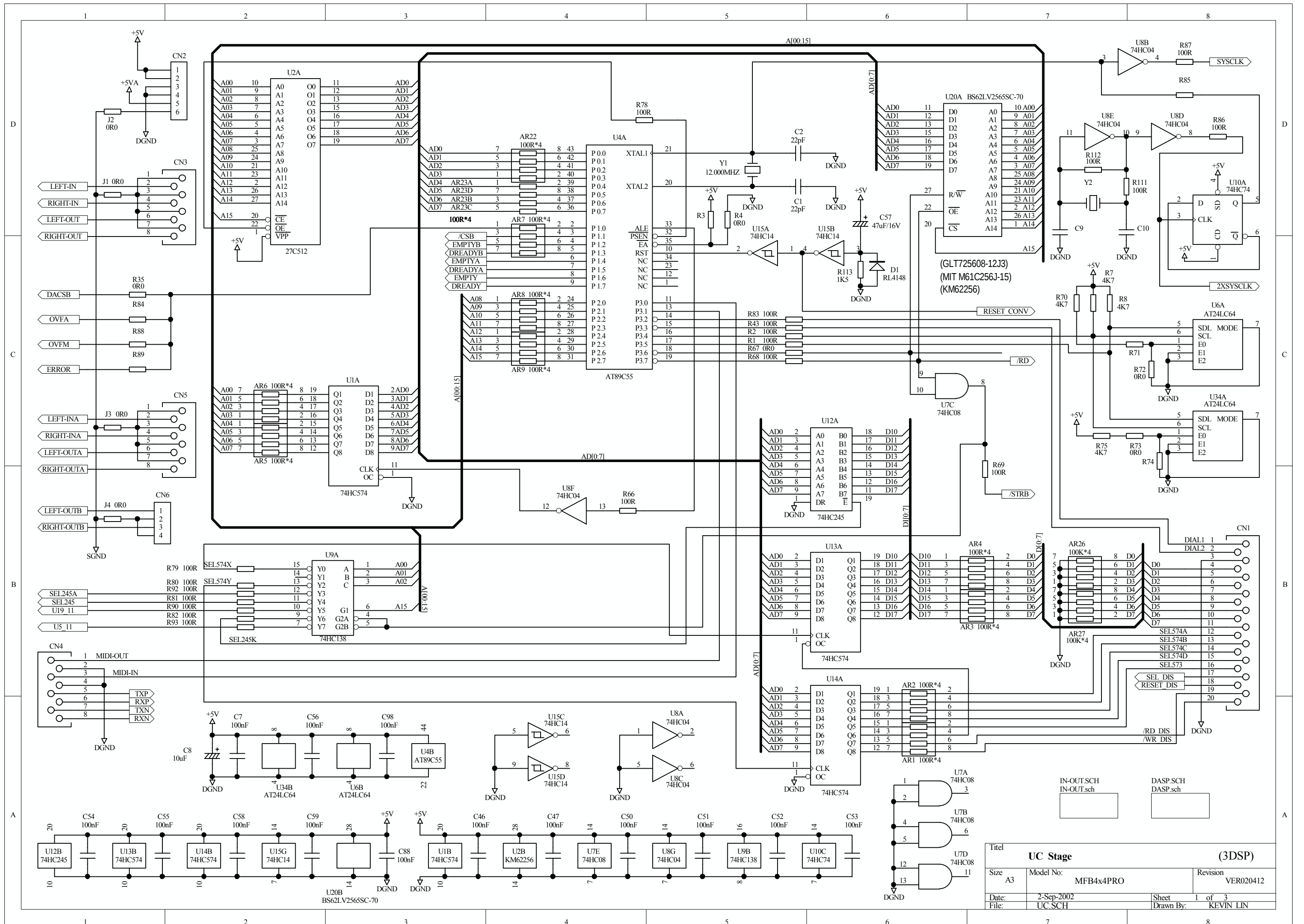

Titel		UC Stage		(3DSP)	
Size	A3	Model No:	MFB4x4PRO	Revision	VER020412
Date:	2-Sep-2002	Sheet	1 of 3		
File:	UC.SCH	Drawn By:	KEVIN LIN		

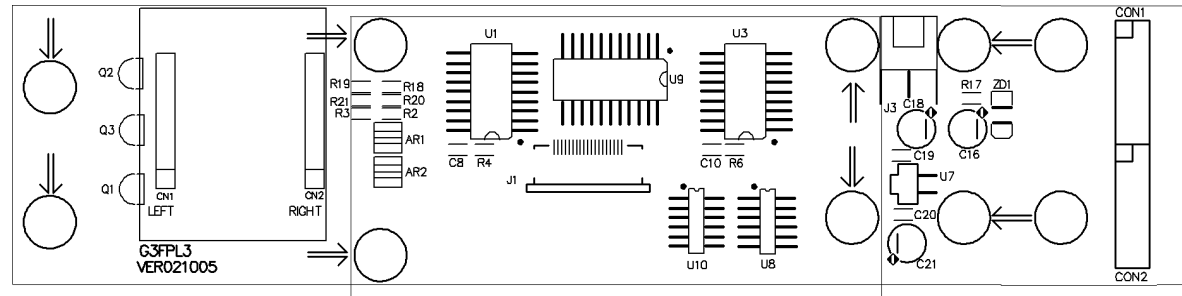

G3FPL3 Top Silkscreen

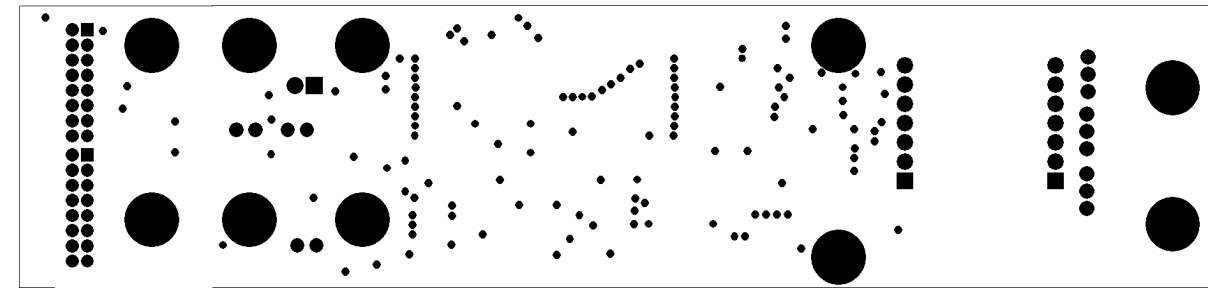

G3FPL3 Bottom Solder Mask

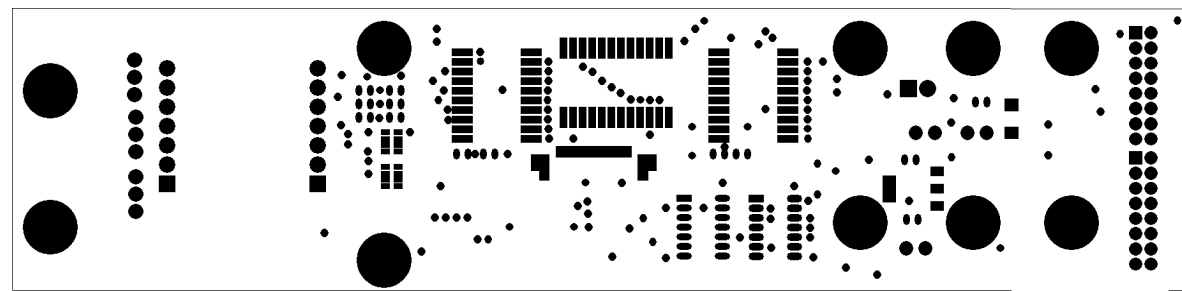

G3FPL3 Top Solder Mask

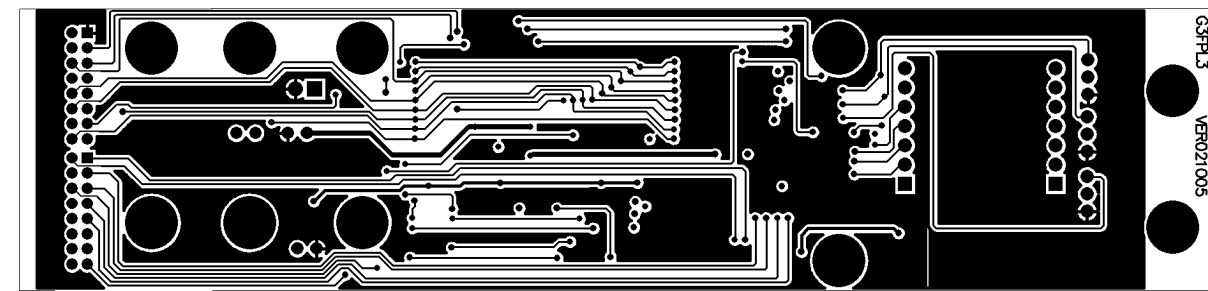

G3FPL3 Bottom Layer

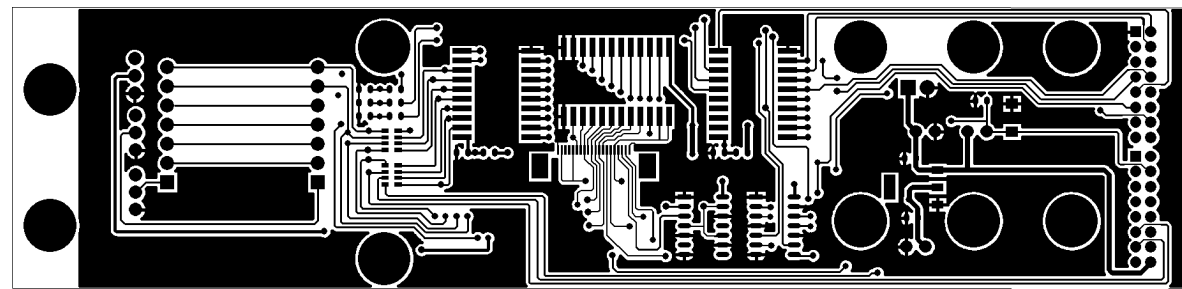

G3FPL3 Top Layer

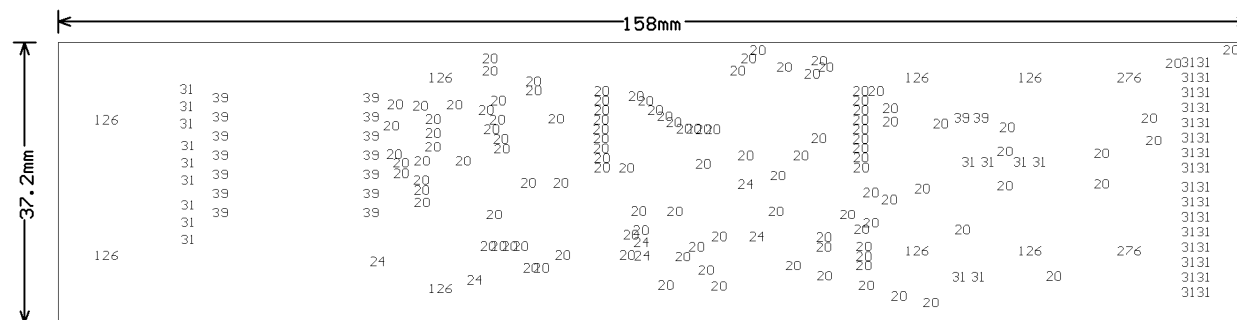

G3FPL3 Drill Drawing

Tool	Hole Size	Hole Count Plated	
T1	20mil (0.508mm)	119	
T2	24mil (0.6096mm)	7	
T3	31mil (0.7874mm)	47	
T4	39mil (0.9906mm)	16	
T5	126mil (3.2004mm)	8	NPTH
T6	276mil (7.0104mm)	2	NPTH
Totals		198	

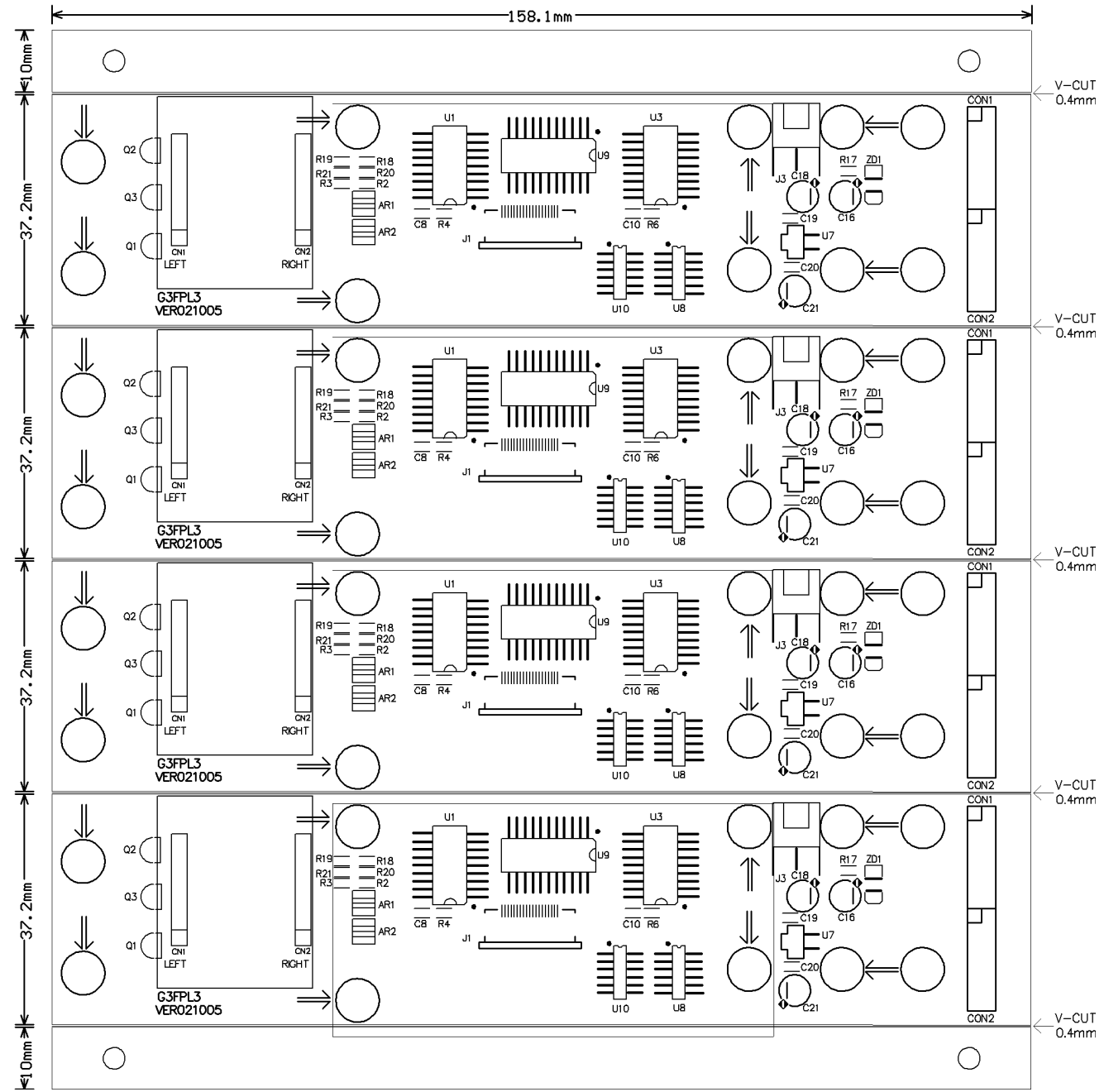

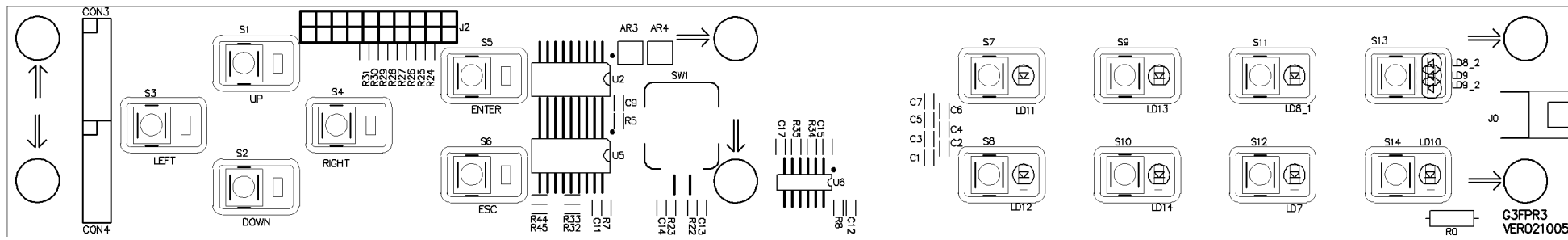

G3FPR3 Top Silkscreen

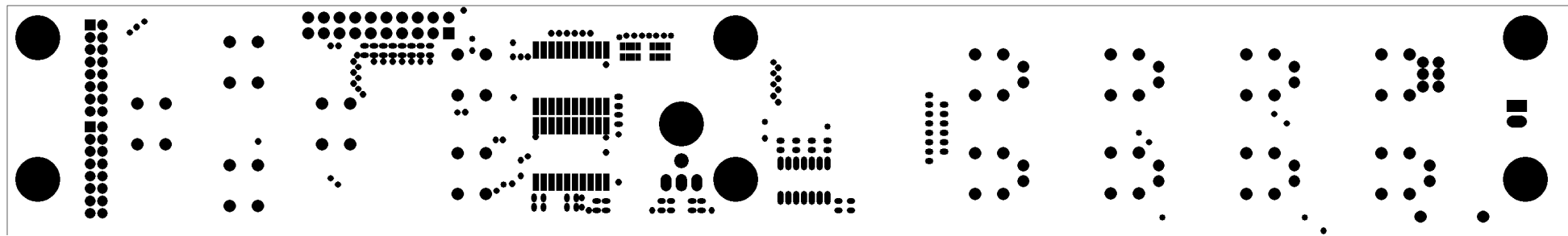

G3FPR3 Top Solder Mask

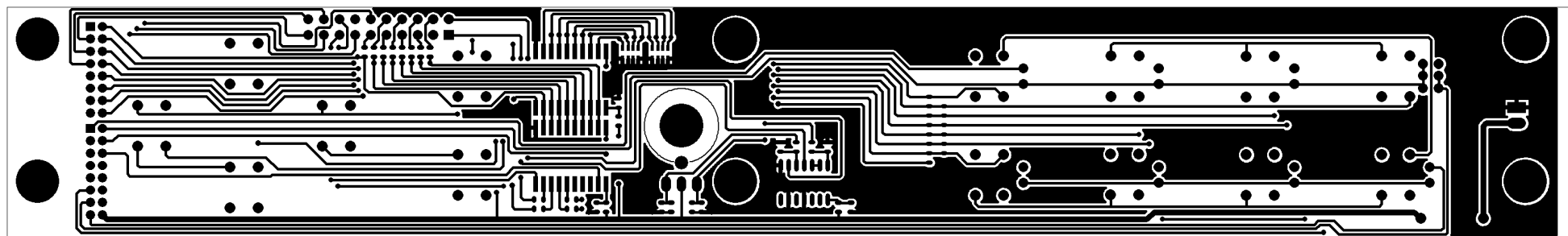

G3FPR3 Top Layer

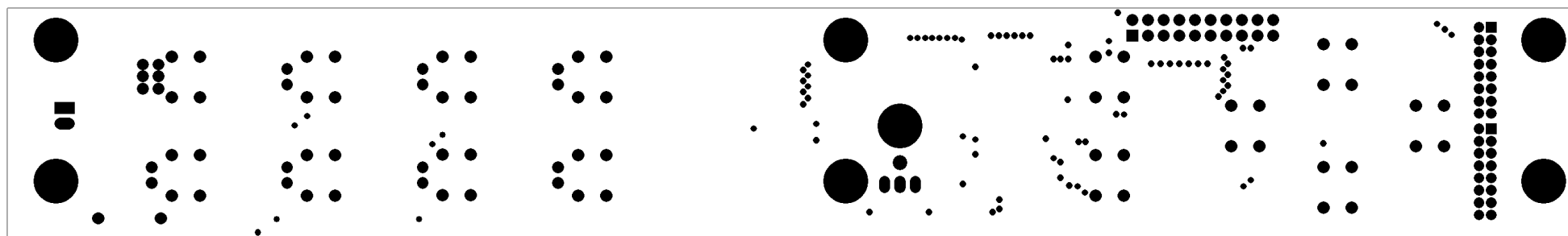

G3FPR3 Bottom Solder Mask

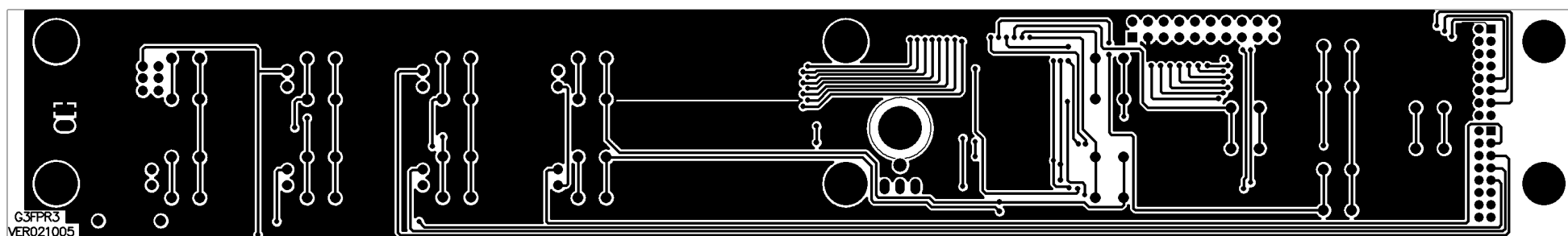

G3FPR3 Bottom Layer

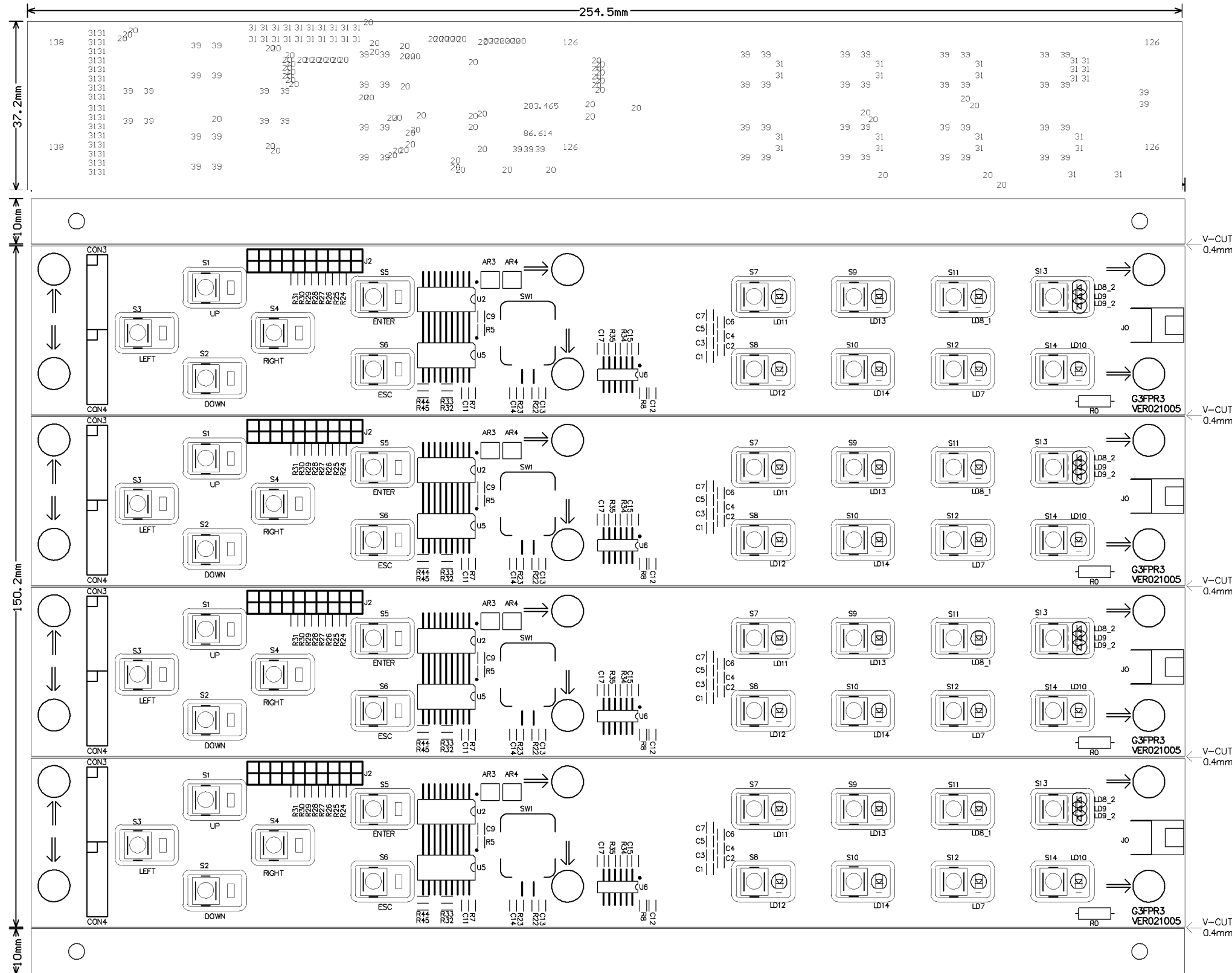

G3FPR3 Drill Drawing

Tool	Hole Size	Hole Count Plated	
T1	20mil (0.508mm)	84	
T2	31mil (0.7874mm)	74	
T3	39mil (0.9906mm)	61	
T4	87mil (2.2098mm)	1	
T5			
T6	280mil (7.112mm)	1	
T8	126mil (3.2004mm)	4	NPTH
T9	138mil (3.5052mm)	2	NPTH
Totals		227	

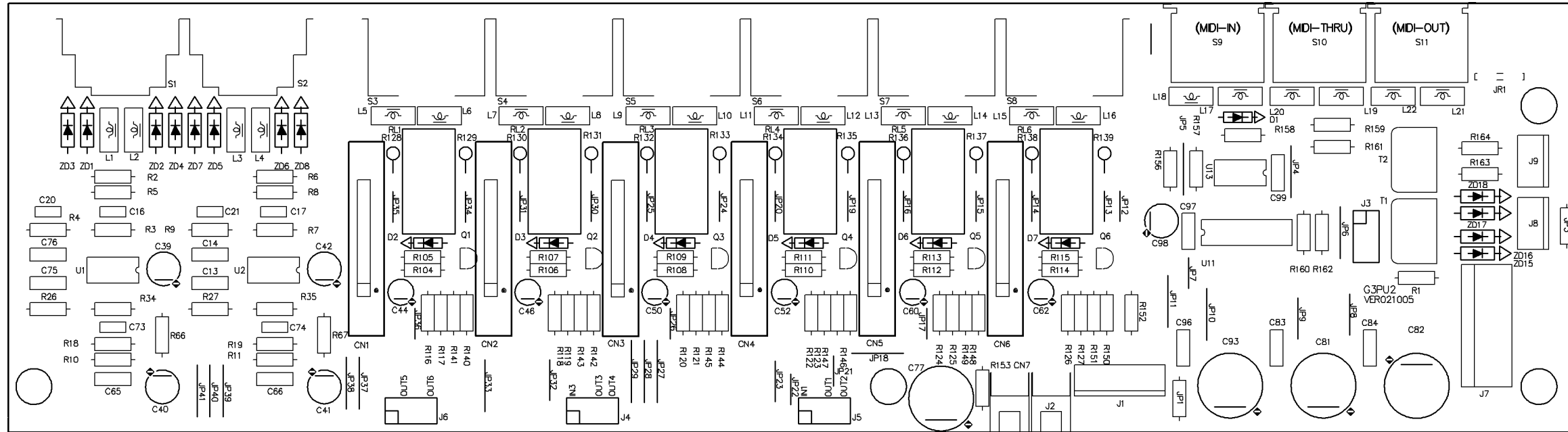

G3PU2 Top Scilkscreen

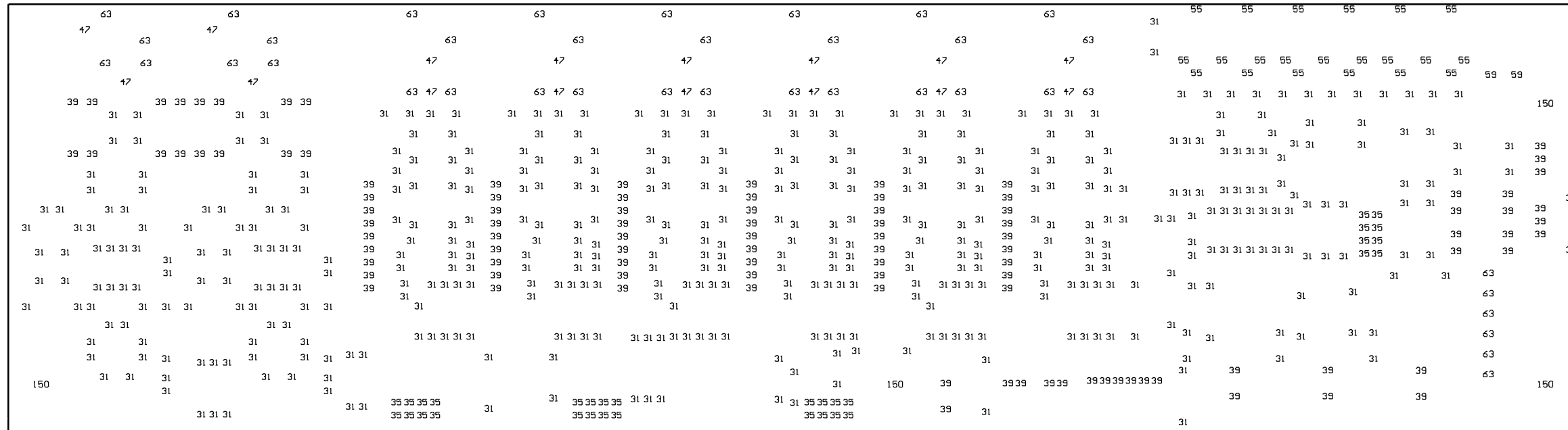

G3PU2 Drill Drawing

Tool	Hole Size	Hole Count Plated
T1	31mil (0.7874mm)	464
T2	35mil (0.889mm)	32

T3	39mil (0.9906mm)	102
T4	47mil (1.1938mm)	16
T5	55mil (1.397mm)	21
T6	59mil (1.4986mm)	2

T7	63mil (1.6002mm)	26
T8	150mil (3.81mm)	4
T9	63mil (1.6002mm)	12
Totals		679

NPTH

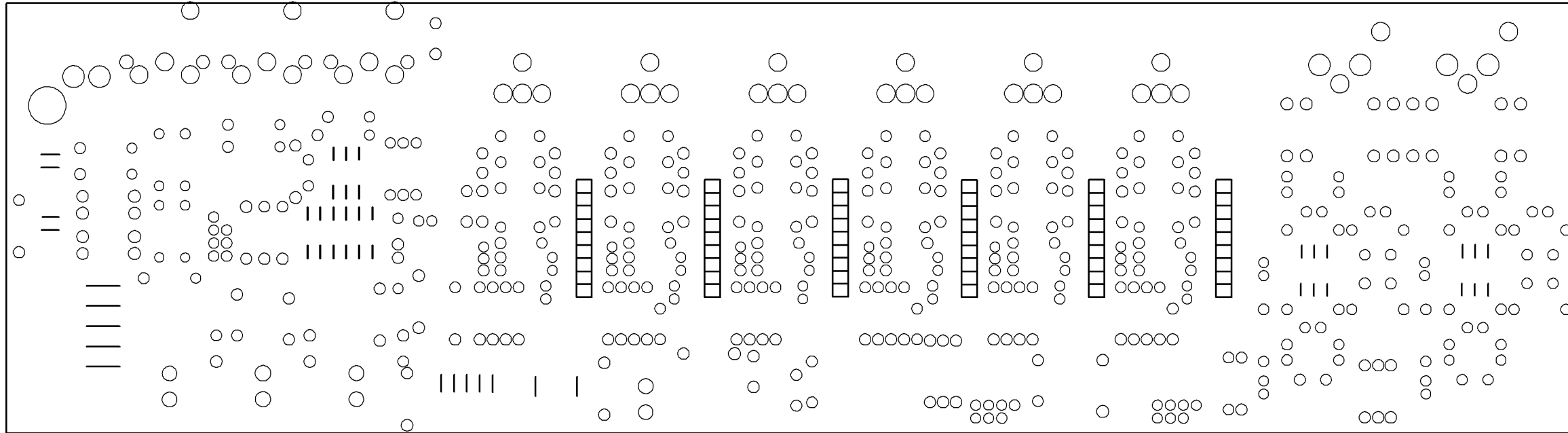

G3PU2 Bottom Scilkscreen

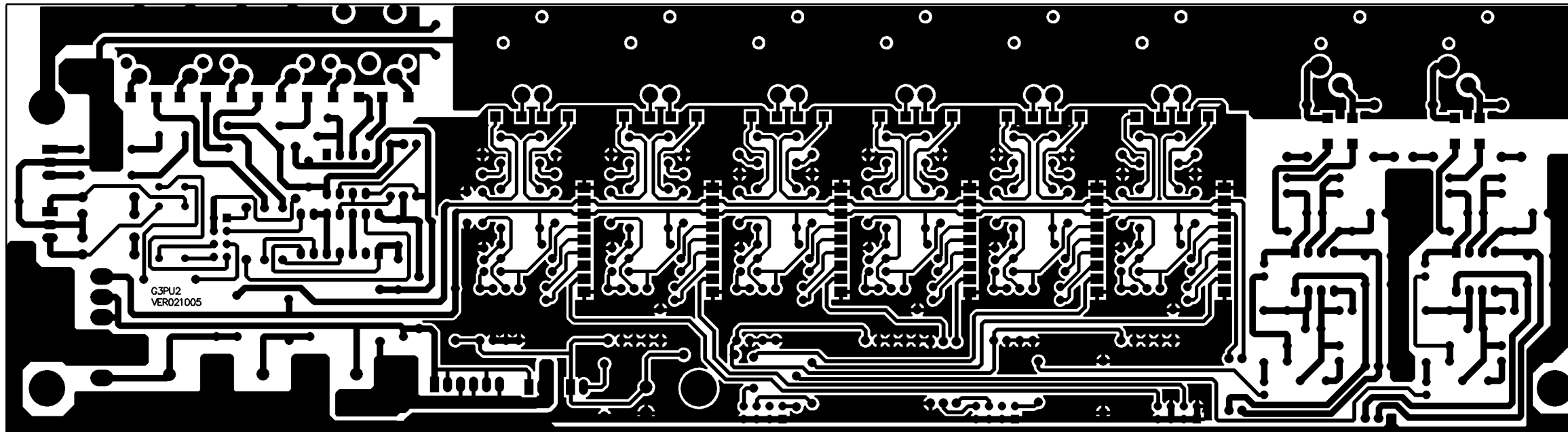

G3PU2 Bottom Layer

G3PU2
VER021005

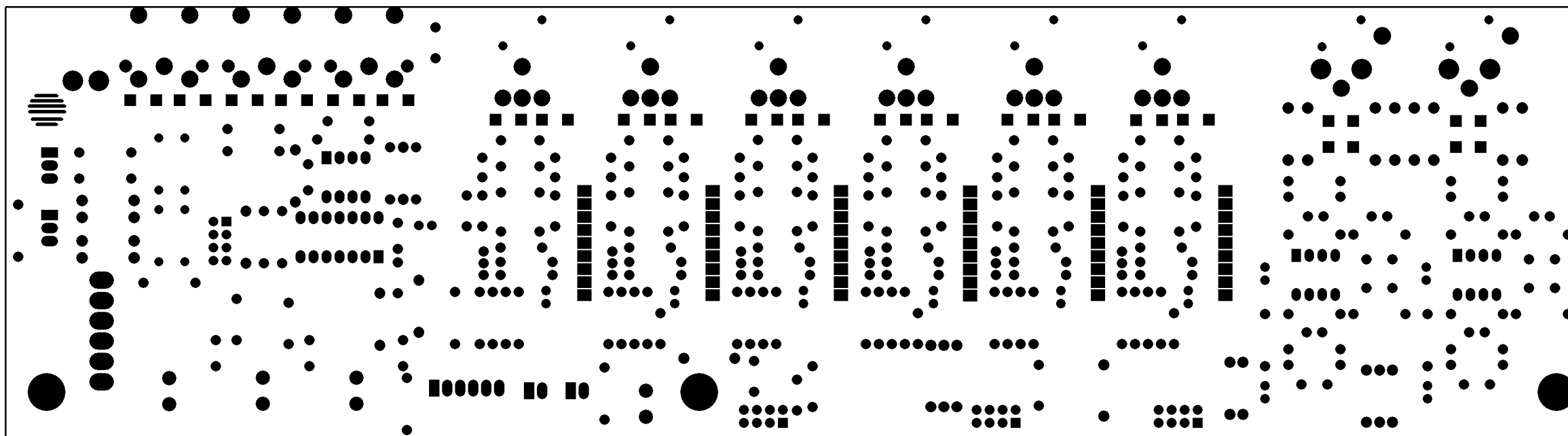

G3PU2 Bottom Solder Mask

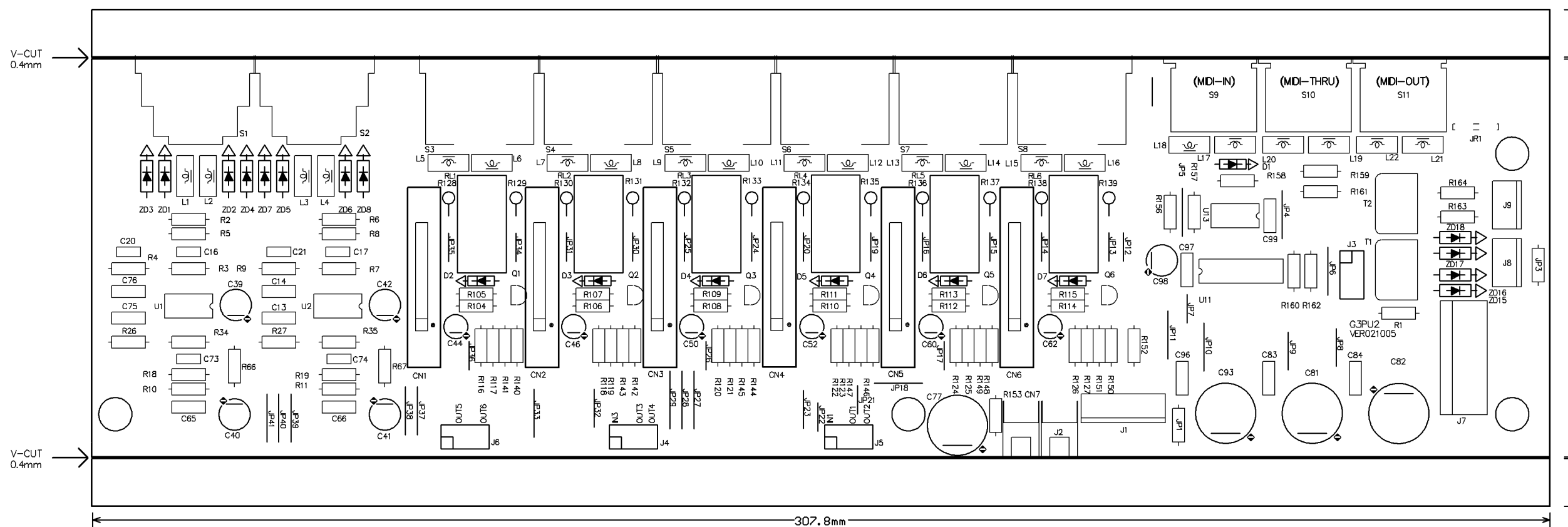

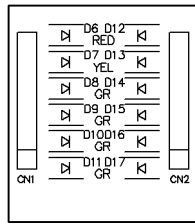

G3LED Top Silkscreen

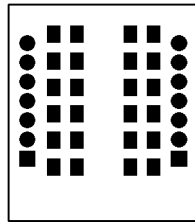

G3LED Top Solder Mask

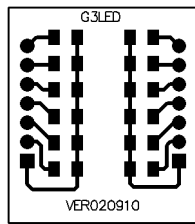

G3LED Top Layer

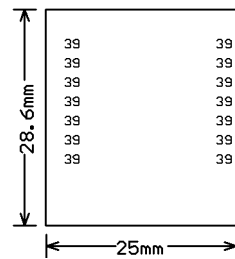

G3LED Drill Drawing

Tool	Hole Size	Hole Count Plated
T1	39mil (0.9906mm)	14
Totals		14

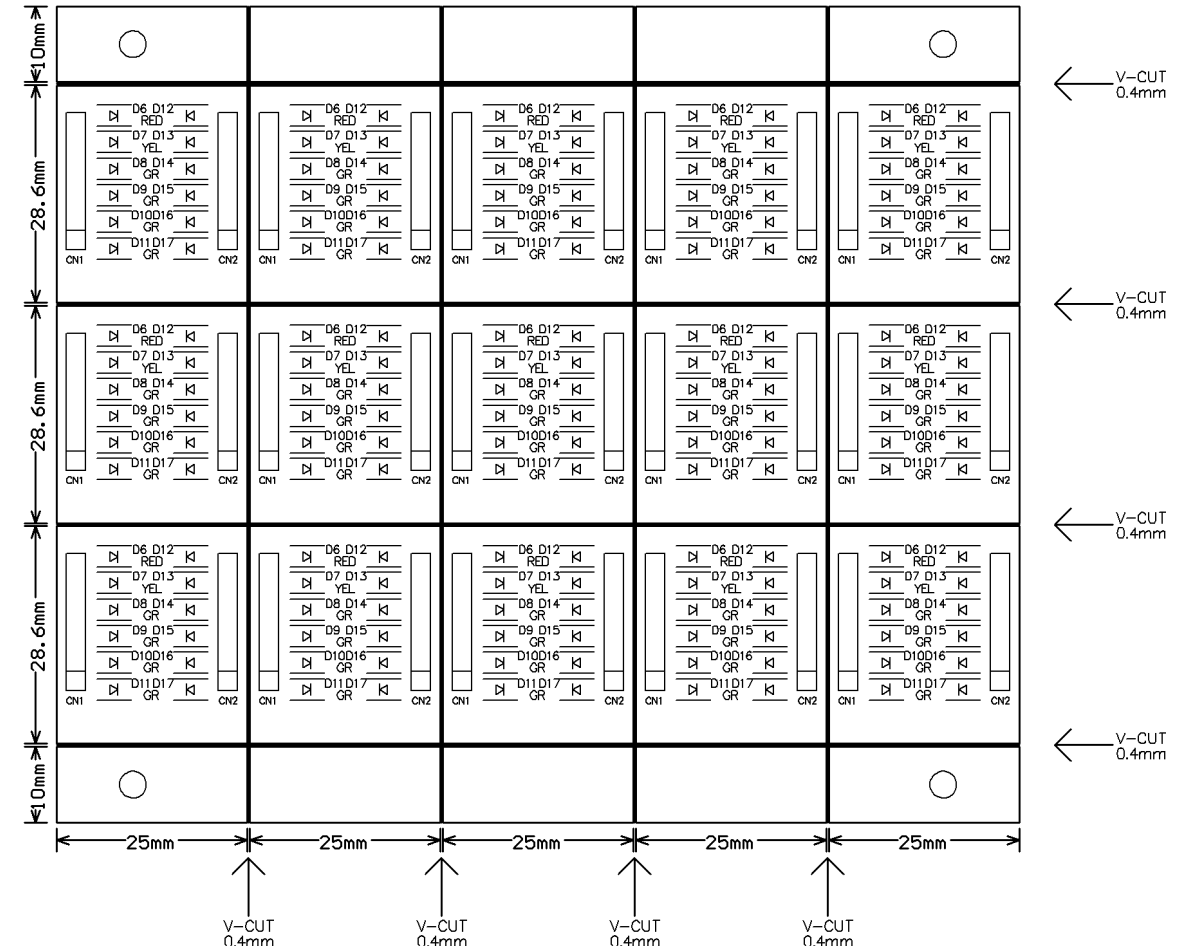

PCB#MFB4x4PRO TOP LAYER

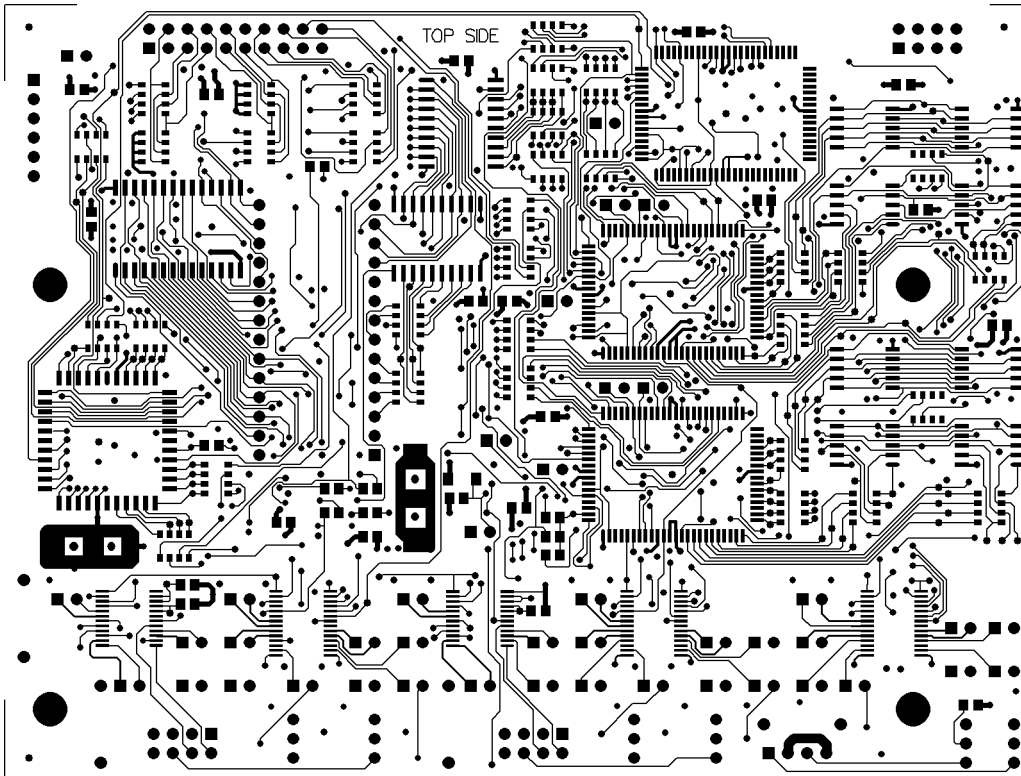

SEED-cod. MFB4x4PRO VER020830

PCB#MFB4x4PRO TOP SOLDER MASK

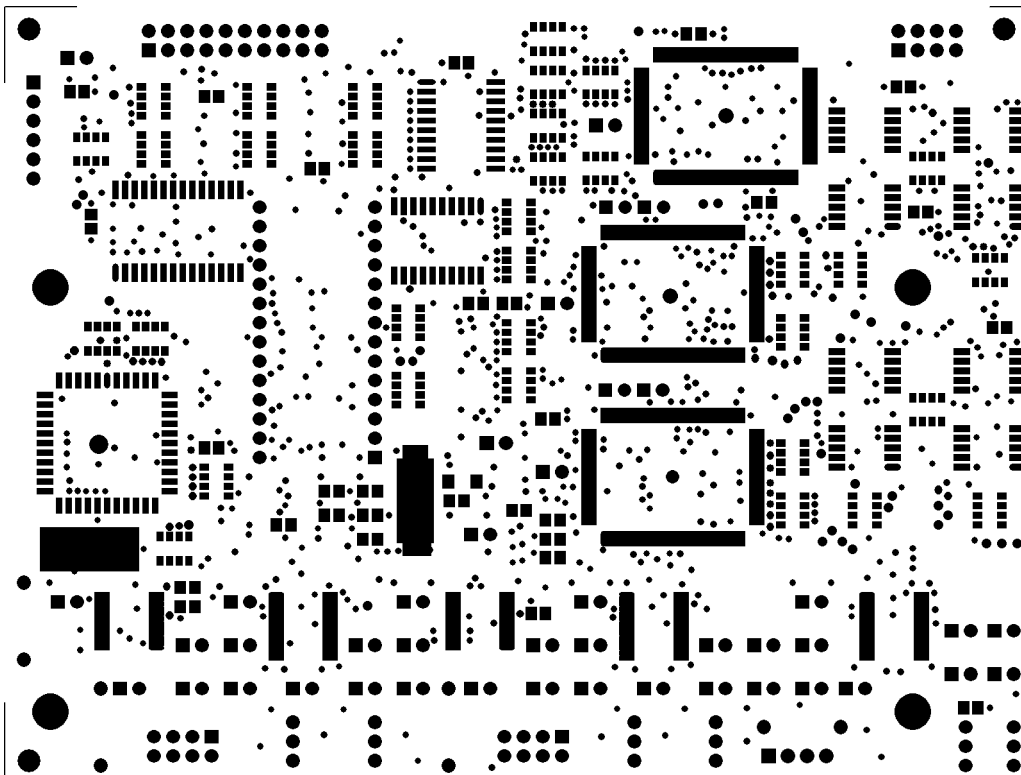

PCB#MFB4x4PRO BOTTOM LAYER

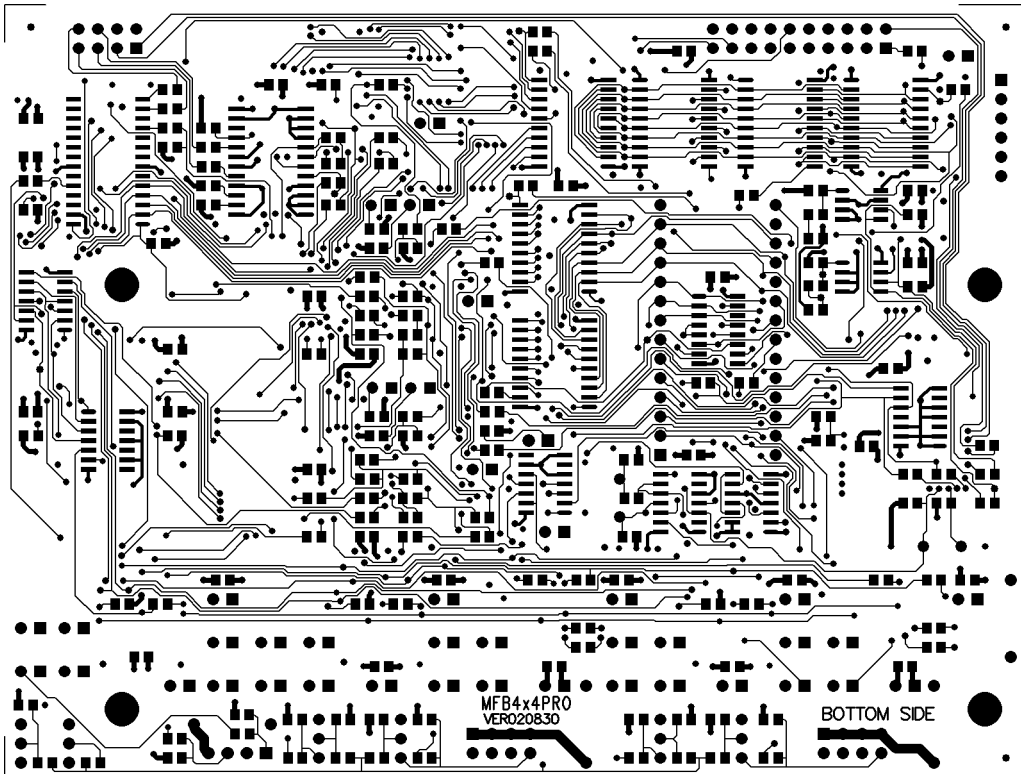

SEED-cod. MFB4x4PRO VER020830

PCB#MFB4x4PRO BOTTOM SOLDER MASK

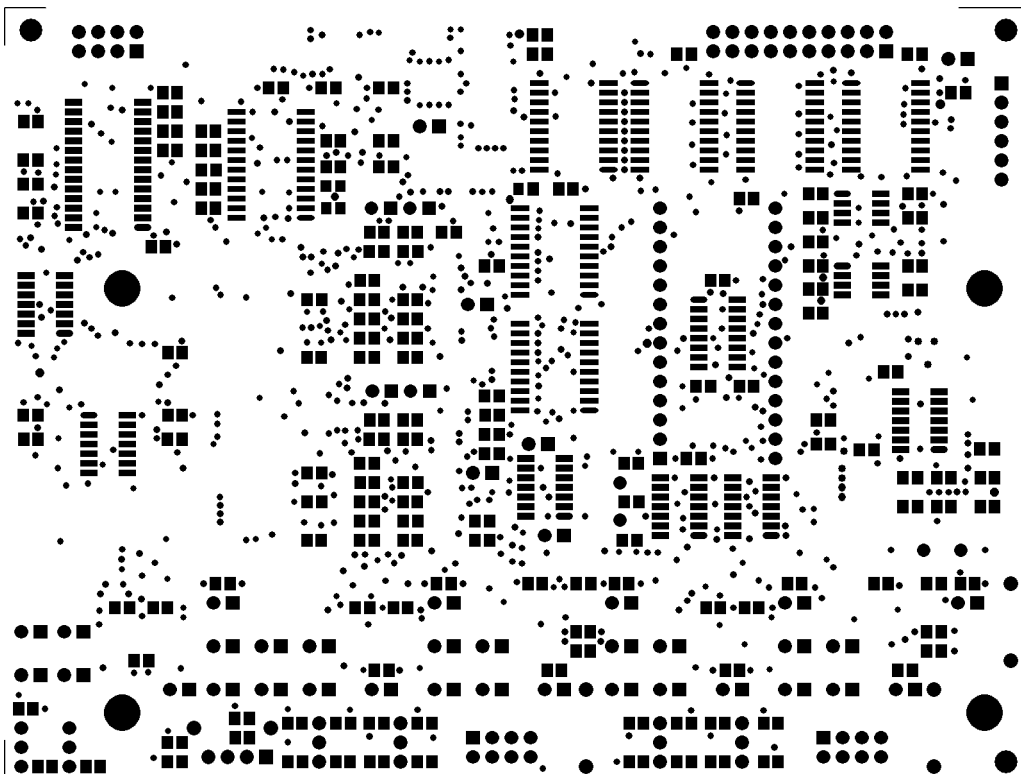

PCB#MFB4x4PRO INTERNAL PLANE1 (VCC)



INTERNAL PLANE1(VCC)

PCB#MFB4x4PRO INTERNAL PLANE2 (GND)



INTERNAL PLANE2(GND)

PCB#MFB4x4PRO SILKSCREEN TOP LAYER

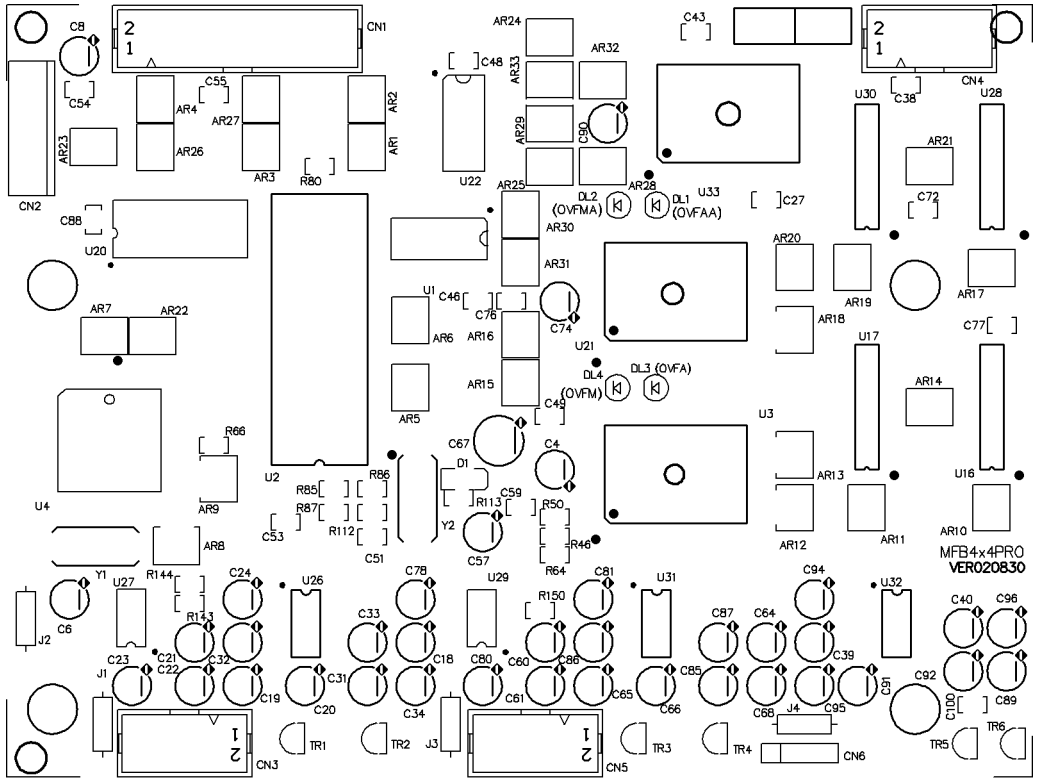

SILKSCREEN TOP

PCB#MFB4x4PRO SILKSCREEN BOTTOM LAYER

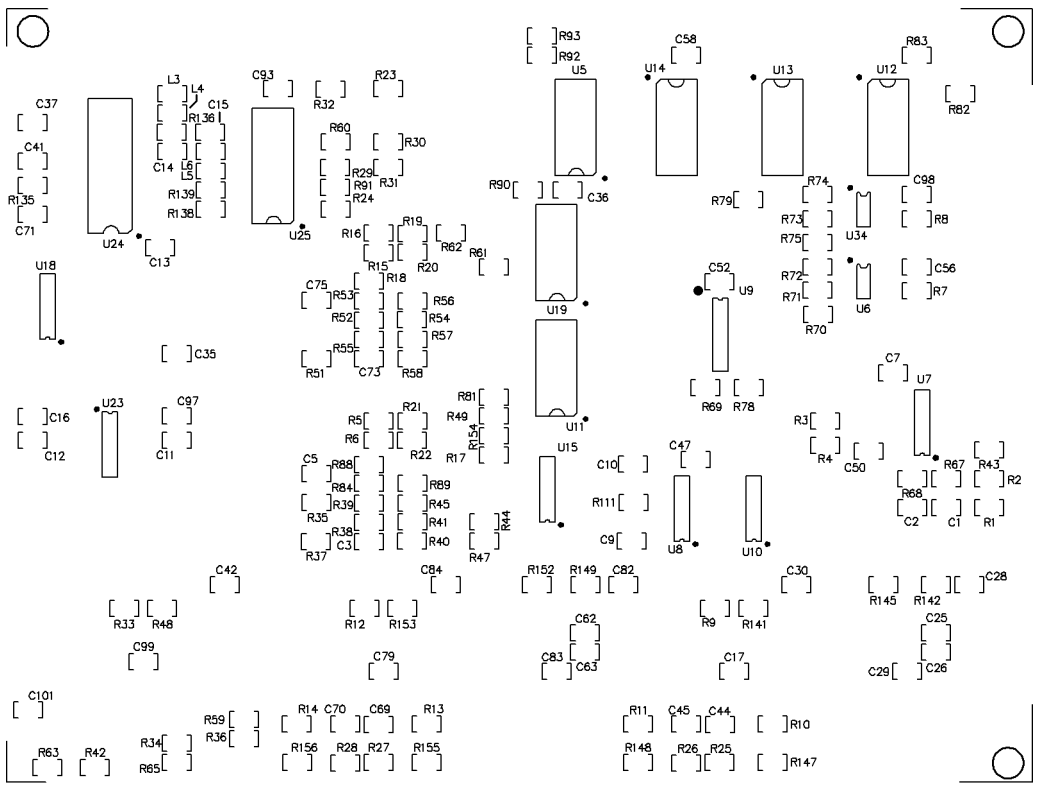

SILKSCREEN BOTTOM

PCB#MFB4x4PRO DRILL DRAWING

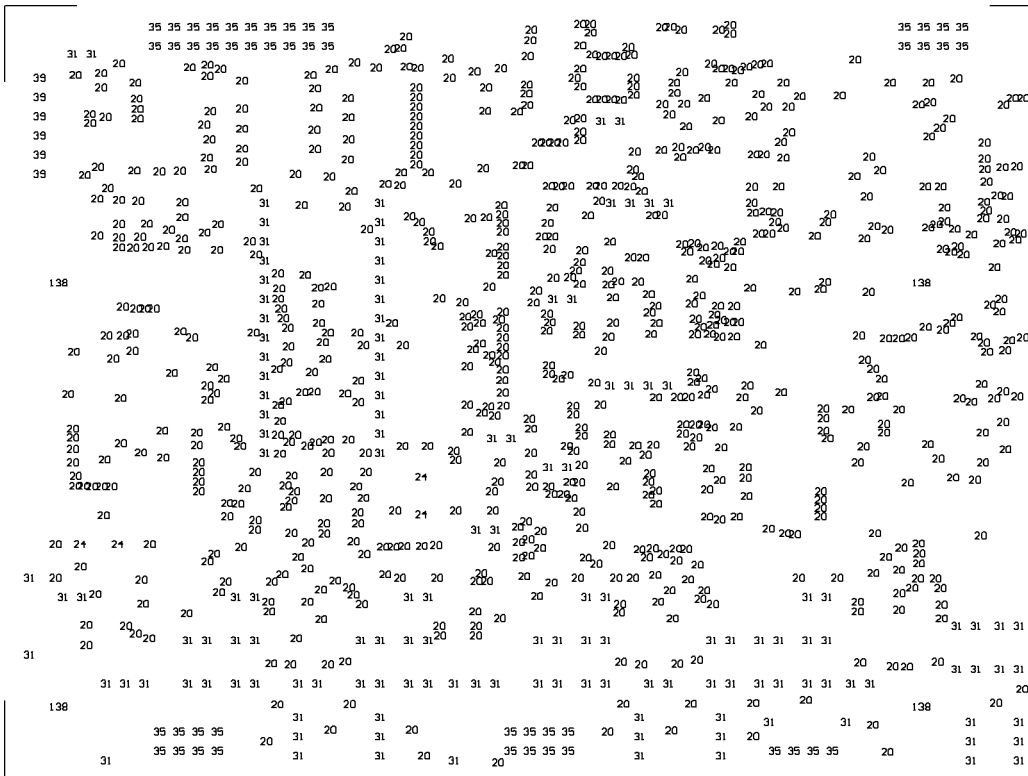

NCDrill File Report For: MFB4x4PRO.PCB 31-Aug-2002

Layer Pair : TopLayer to BottomLayer

ASCII File : NCDrillOutput.TXT

EIA File : NCDrillOutput.DRL

Tool	Hole Size	Hole Count	Plated
T1	20mil (0.508mm)	742	
T2	24mil (0.6096mm)	4	
T3	31mil (0.7874mm)	138	
T4	35mil (0.889mm)	48	
T5	39mil (0.9906mm)	6	
T6	138mil (3.5052mm)	4	NPTH
Totals		942	

G3FPL3 (VER021005)

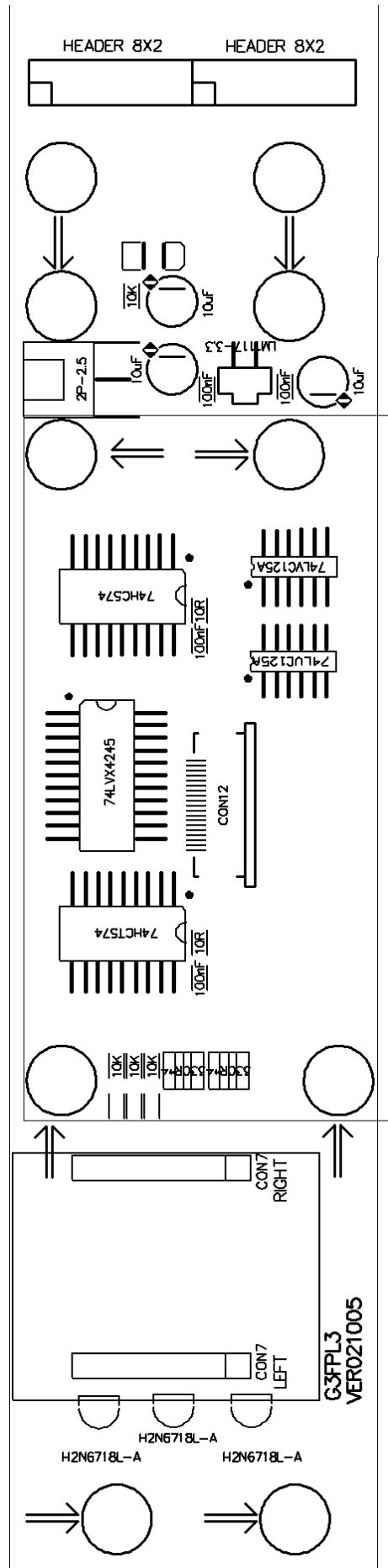
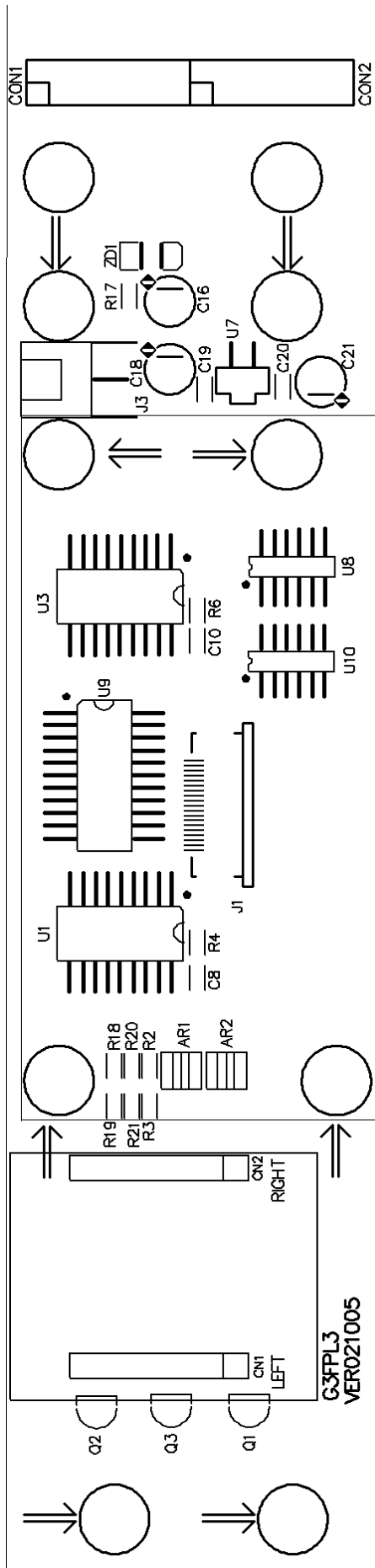

G3FPR3 (VER021005)

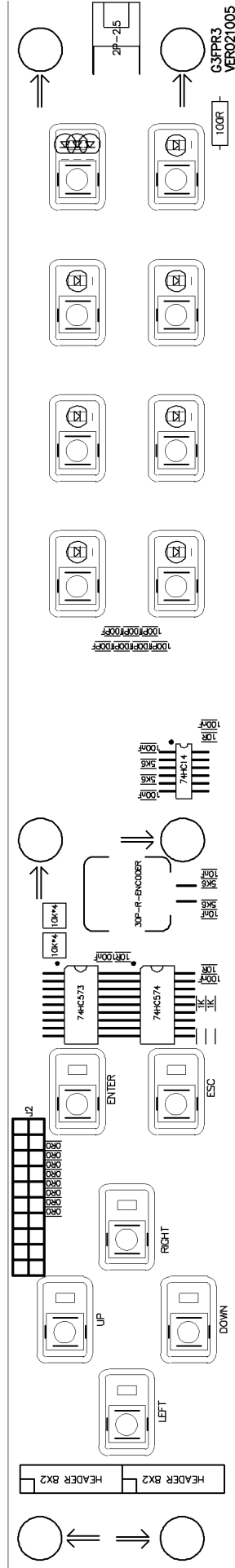
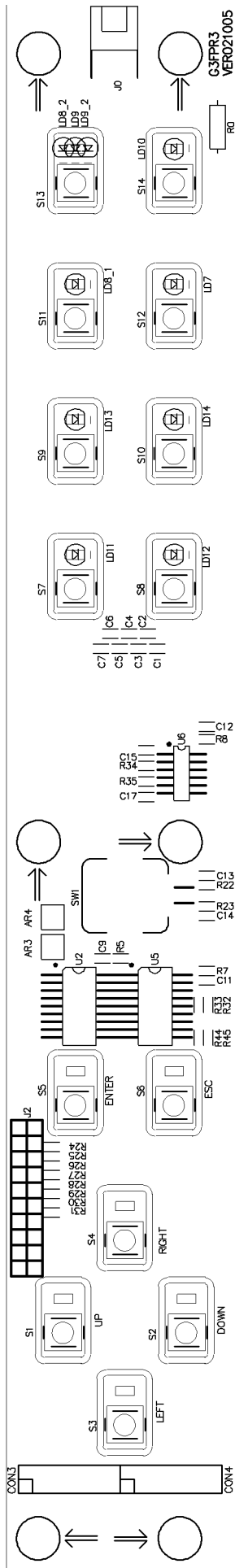

G3PU2 (VER021005)

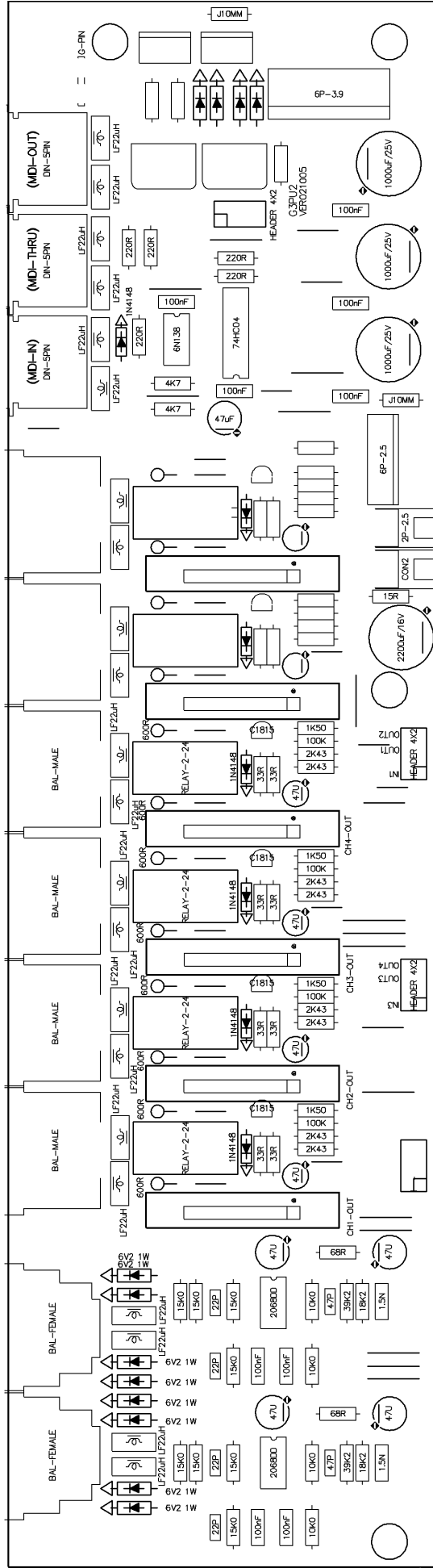
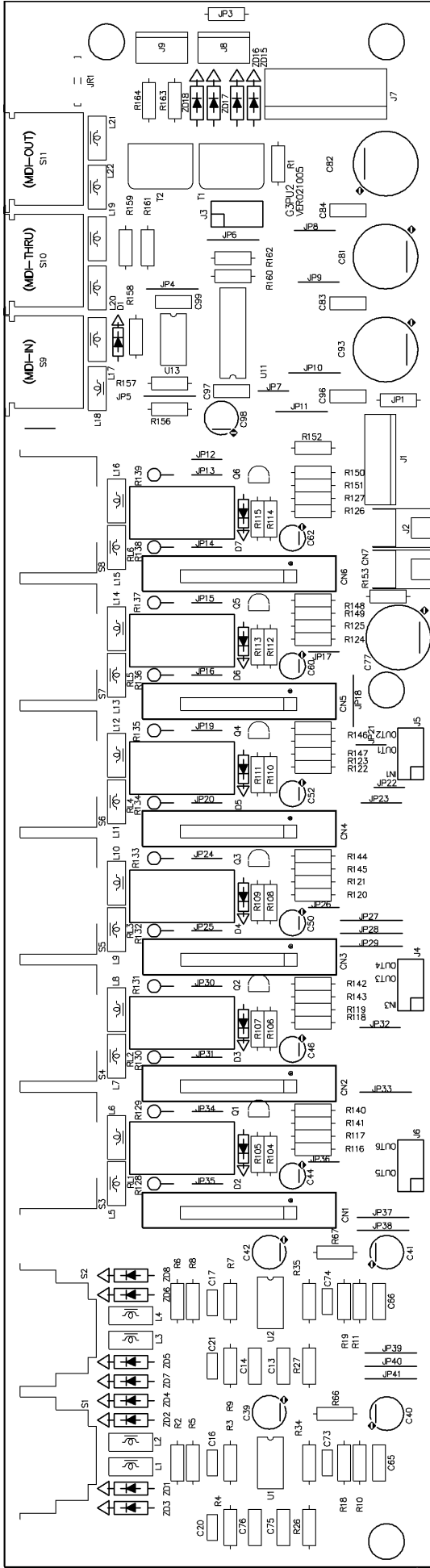

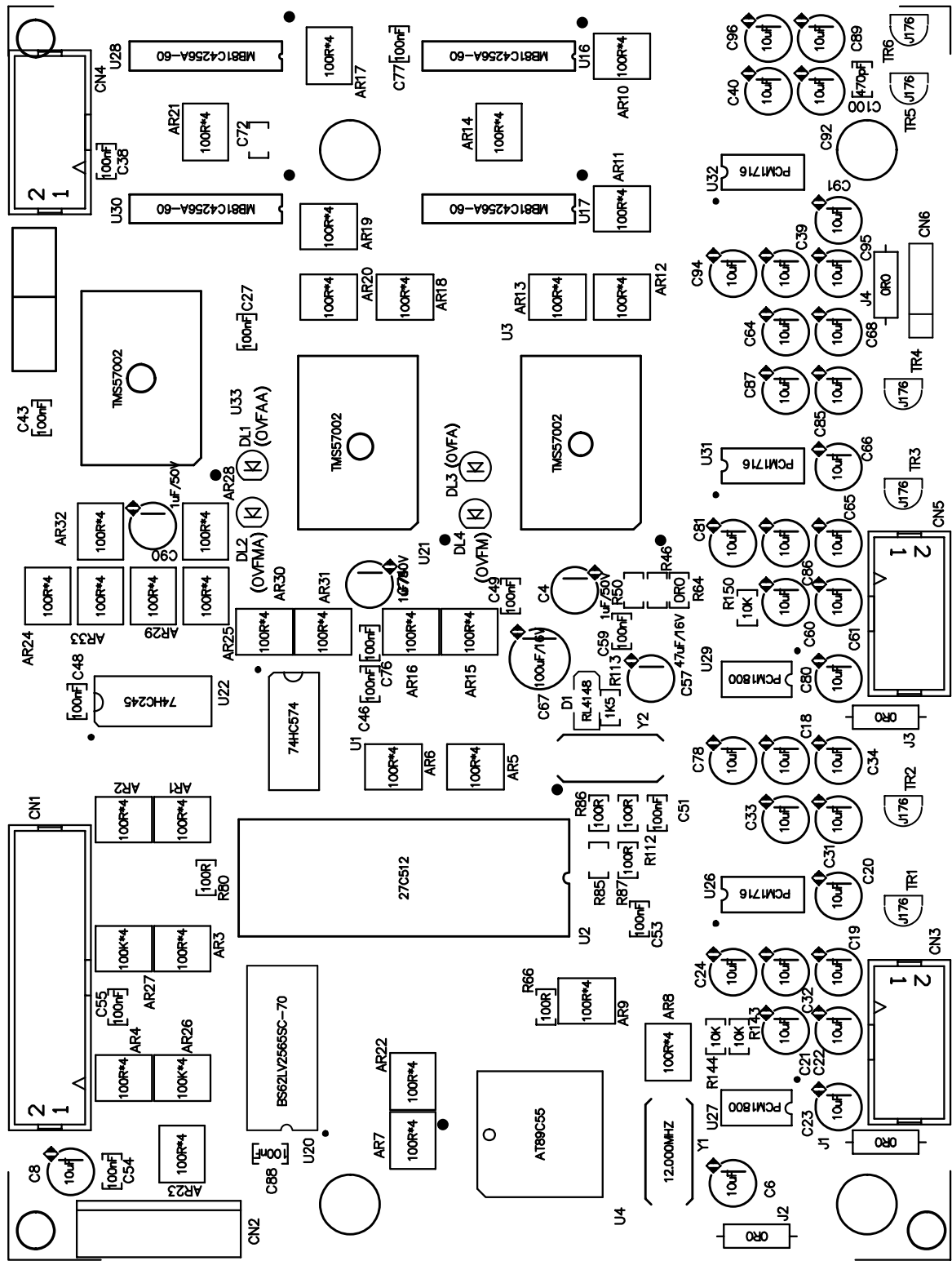

SILKSCREEN TOP

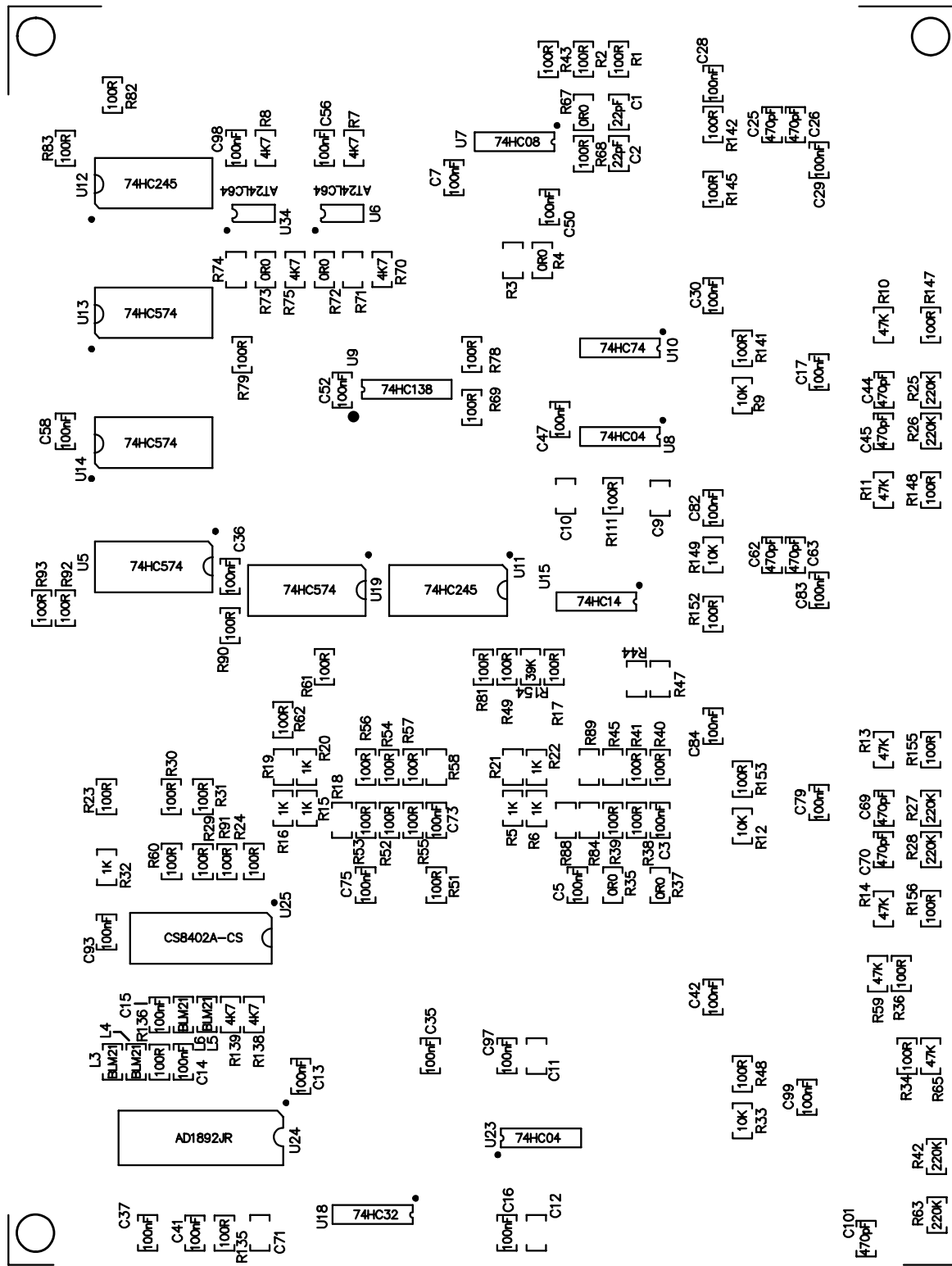

SILKSCREEN BOTTOM

