

Service Manual

Model: CLE2.0

Compressor / Limiter / Gate



www.altoproaudio.com

Version: 1.1

CONTENTS

- 1. Specification**
- 2. Block Diagram**
- 3. Schematic Diagram**
- 4. Printed Circuit Board**
- 5. Wiring Diagram**
- 6. ~~Test Procedure~~**
- 7. Electrical Parts List**
- 8. Exploded Views & Mechanical Parts List**
- 9. Notes**

1.Specification

INPUT		
Connectors	XLR and 1/4" TRS (Pin 2 and Tip hot)	
Type	Electronically balanced/unbalanced, RF filtered	
Impedance	Balanced >50Kohm, Unbalanced>25Kohm	
Nominal operating level	+4dBu/-10dBV switchable	
Max input level	>+24dBu balanced and unbalanced	
CMRR	Typically>50dB at 1KHz	

OUTPUT		
Connectors	XLR and 1/4" TRS (Pin 2 and Tip hot)	
Type	Electronically balanced/unbalanced, RF filtered	
Impedance	Balanced 120ohm, Unbalanced>60ohm	
Max output level	>+21dBu,+20dBm balanced and unbalanced	

SIDECCHAIN INPUT		
Connectors	1/4" TRS (Tip hot)	
Type	RF-rejecting, DC de-coupled, unbalanced input	
Impedance	>10Kohm	
Max input level	>+24dBu	

SIDECCHAIN OUTPUT		
Connectors	1/4" TRS (Tip hot)	
Type	RF-rejecting, DC de-coupled, unbalanced output	
Impedance	2Kohm	
Max input level	>+21dBu	

SYSTEM SPECIFICATIONS		
Bandwidth	20HZ to 20kHz, +0/-0.5dB	
Frequency Response	0.35Hz to 200kHz,+0/-3dB	
Noise	>-95dBu, unweighted, 22Hz to 22kHz	
THD	<0.008% Typical at +4dBu, 1kHz, unity gain <0.04% Typical at +20dBu, 1kHz, unity gain	
IMD	<0.1% Typical SMPTE	
Crosstalk	<-100dB, 22Hz to 22Khz	
Stereo Coupling	True RMS detection	

EXPANDER/GATE SECTION		
Type	Interactive Expander (Interactive Ratio Control)	
Threshold	variable (OFF to +15dB)	
Ratio	variable (1:1 to 1:8)	
Attack	<1ms/50dB, program dependent	
Release	variable (SLOW:100ms/1dB,FAST:100ms/100Db)	

COMPRESSOR SECTION		
Type	Interactive Compressor (Interactive Knee Adaptation)	
Threshold	variable (-40dB to +20dB)	
Ratio	variable (1:1 to :1)	
Threshold Characteristic	variable (Interactive or Hard Knee)	
Manual Attack Time	variable (0.5ms to 100ms / 20dB)	
Manual Release Time	variable from 0.05 ms to 5s / 20dB	
Auto Attack Time	Typical 15ms at 10dB, 5ms at 20dB, 3ms at 30dB	
Auto Release Time	Program dependent, typical 125dB/s	
Output level	variable (-20dB to +20dB)	

PEAK LIMITER SECTION		
Type	Interactive Gain Control Peak Limiter	
Threshold	variable (+4dB to OFF (+22dBu))	
Ratio	:1	
Stage 1 Limiter Type	Clipper	
Attack Time	“zero”	
Release Time	“zero”	
Stage 2 Limiter Type	Program Limiter	
Attack	program dependent, typ. <5ms	
Release	program dependent, typ. 20dB/s	

FUNCTION SWITCHES		
SC EXTERN	Switches the detector section to the external SC input.	
SC MON	Monitoring the external SC input, disengaging the normal audio.	
INTERACTIVE	Enables the “Interactive Knee Adaptation” characteristics.	
CONTOUR	Allows for frequency dependent detection.	
AUTO	Enable the automatic and program dependent setting of the Attack-/Release times, disengaging the manual Attack-/Release controls.	
I/O METER	Switches between input and output for the Level Meter.	
IN/OUT	Relay controlled hard-bypass	
OPERATING LEVEL	Changes the internal reference level from +4 dBu to –10dBu.	
COUPLE	Linking both channels for stereo operation. Channel 1 becomes master.	

INDICATORS		
GAIN REDUCTION	12 element LED display: 1/2/4/6/9/12/15/18/21/24/27/30 dB.	
INPUT/OUTPUT LEVEL	8 element LED display: -30/-24/-18/-12/-6/0/+3/+6/+9/+12/+18 dB	
Expander/Gate Threshold	2 LED for under “+” and above “-“	
Compressor Threshold	3 LEDs for under “+”, Interactive “0” and above “-“	
Peak Limiter Threshold	1 LED for indication of limiter function.	
Function switch	LED indicator for each	

POWER SUPPLY

Mains Voltages	USA/Canada ~120VAC, 60Hz U.K./Australia ~240VAC, 50Hz Europe ~230VAC, 50Hz General Export Model ~100-120VAC, ~200-240VAC, 50-60Hz	
Fuse	100-120VAC : 400mA (SLOW-BLOW) 200-240VAC : 200mA (SLOW-BLOW)	
Power consumption	14 Watts	
Mains Connection	Standard IEC receptacle	

PHYSICAL

Dimension	W(483.0)*D(198.0)*H(44.2) mm	
Net Weight	3.3Kg	

2.BLOCK DIAGRAM

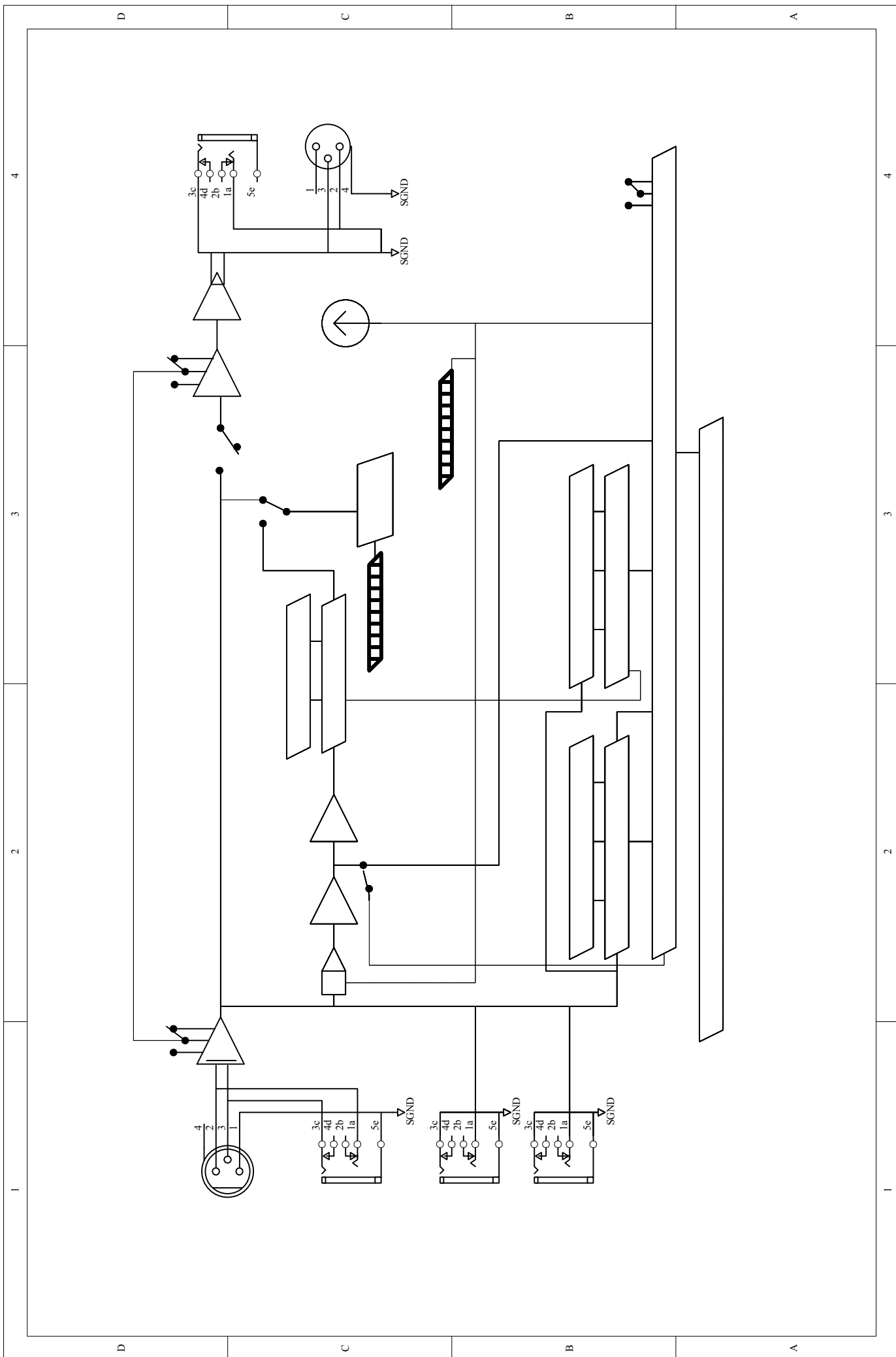

3. Schematic Diagram

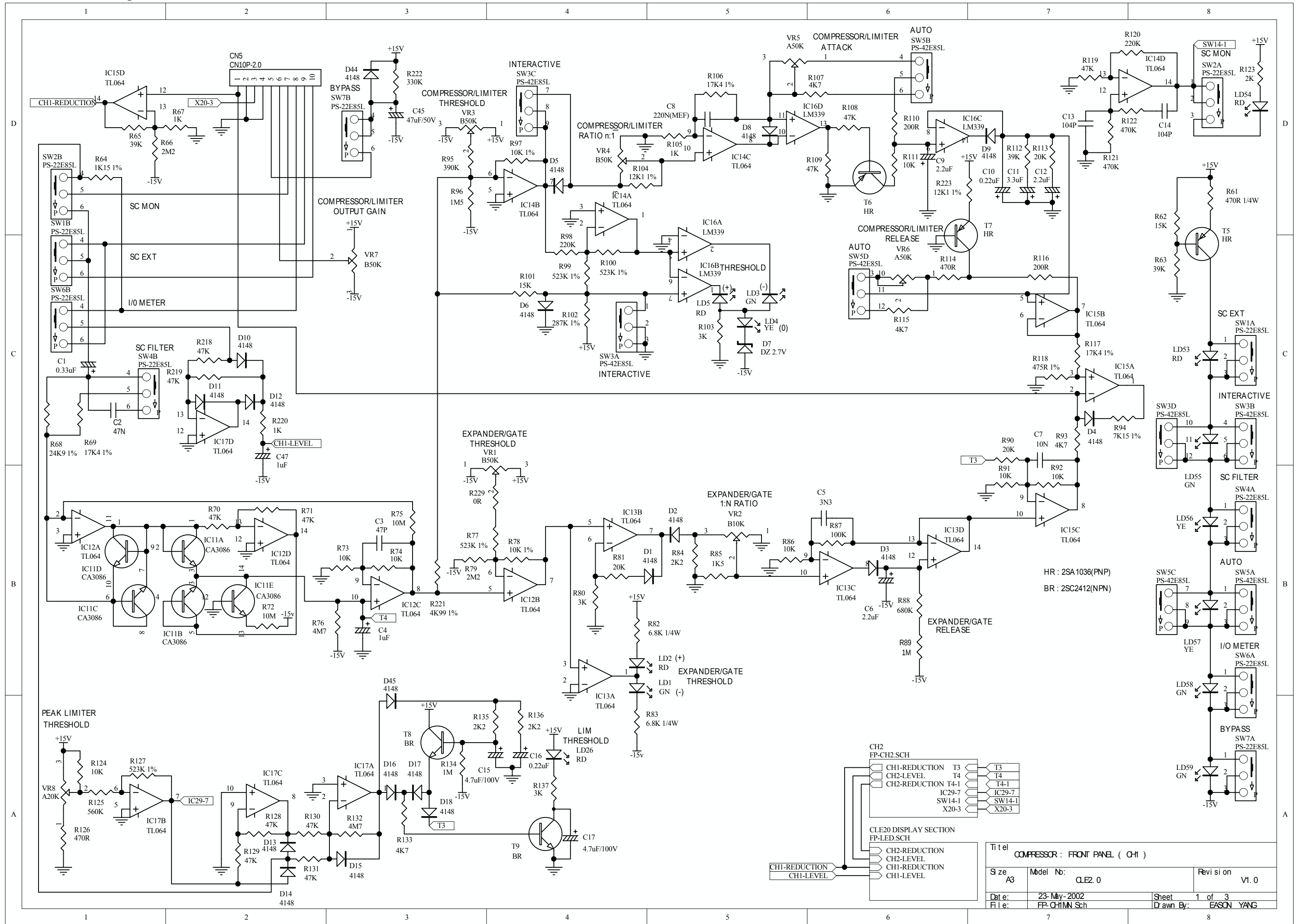

Titel			COMPRESSOR : FRONT PANEL (CH1)			
Size	A3	Model Nb:	CLE2.0		Revisi on	V1.0
Date:	23-May-2002		Sheet	1 of 3		
File:	FP-CH1MN.Sch		Drawn By:	EASON YANG		

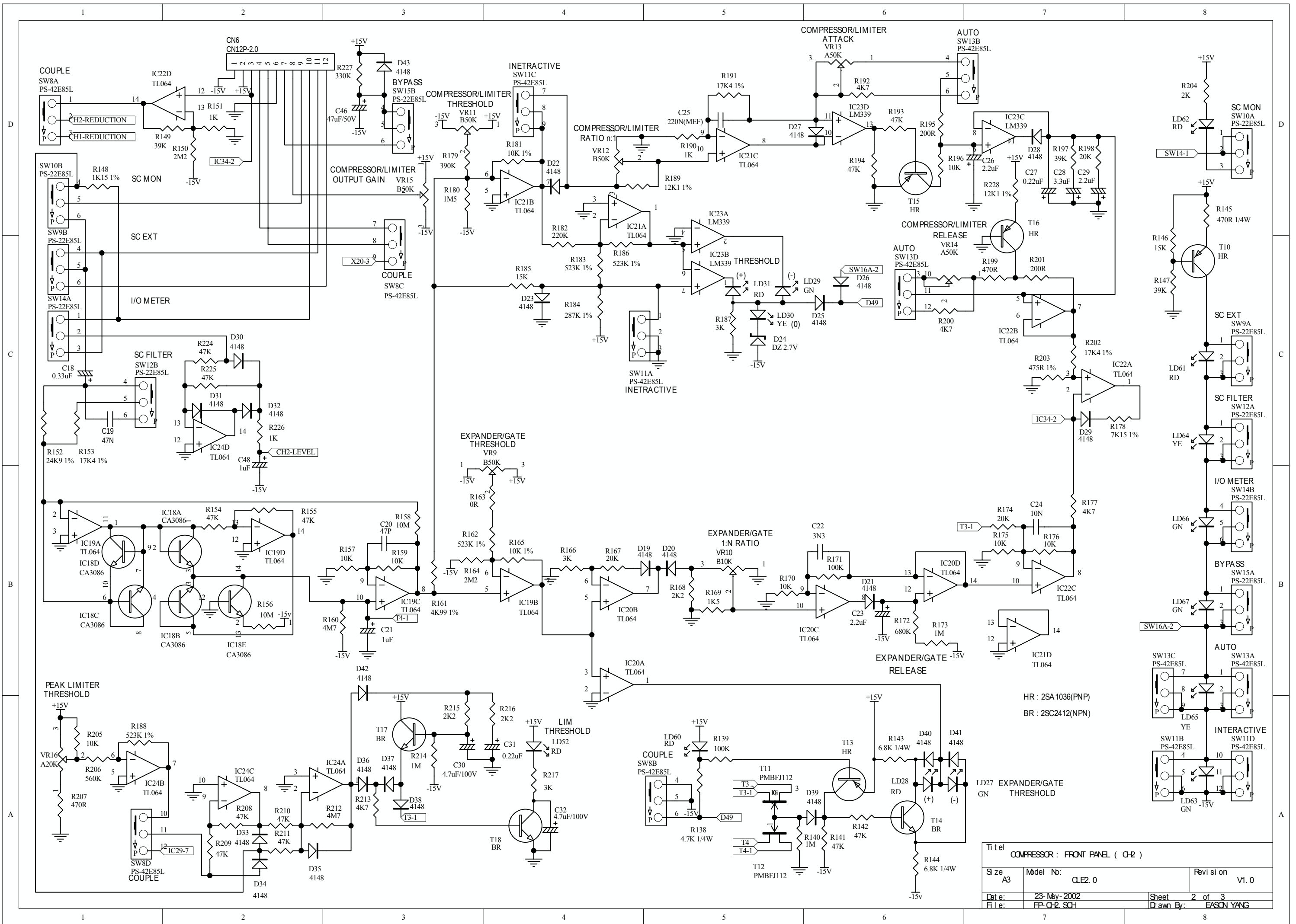

Titel		
COMPRESSOR : FRONT PANEL (CH2)		
Size	Model Nb:	Revisi on
A3	CLEZ.0	V1.0
Date:	23-May-2002	Sheet 2 of 3
File:	FP-CH2.SCH	Drawn By: EASON YANG

HR : 2SA1036(PNP)
BR : 2SC2412(NPN)

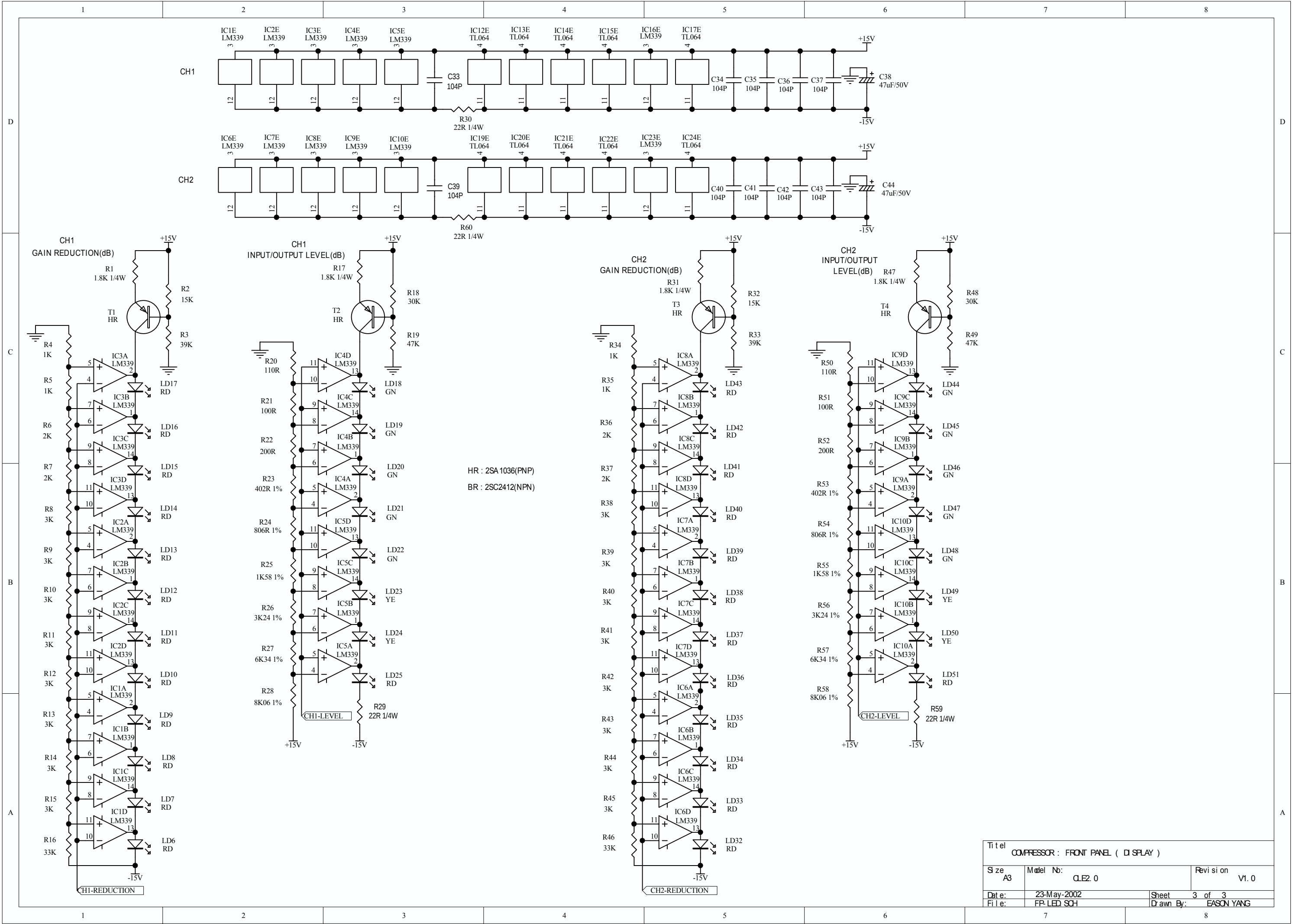

Titel		
COMPRESSOR : FRONT PANEL (DISPLAY)		
Size	Model Nb:	Revisi on
A3	CLE2.0	V1.0
Date:	23-May-2002	Sheet 3 of 3
File:	FP-LED.SCH	Drawn By: EASON YANG

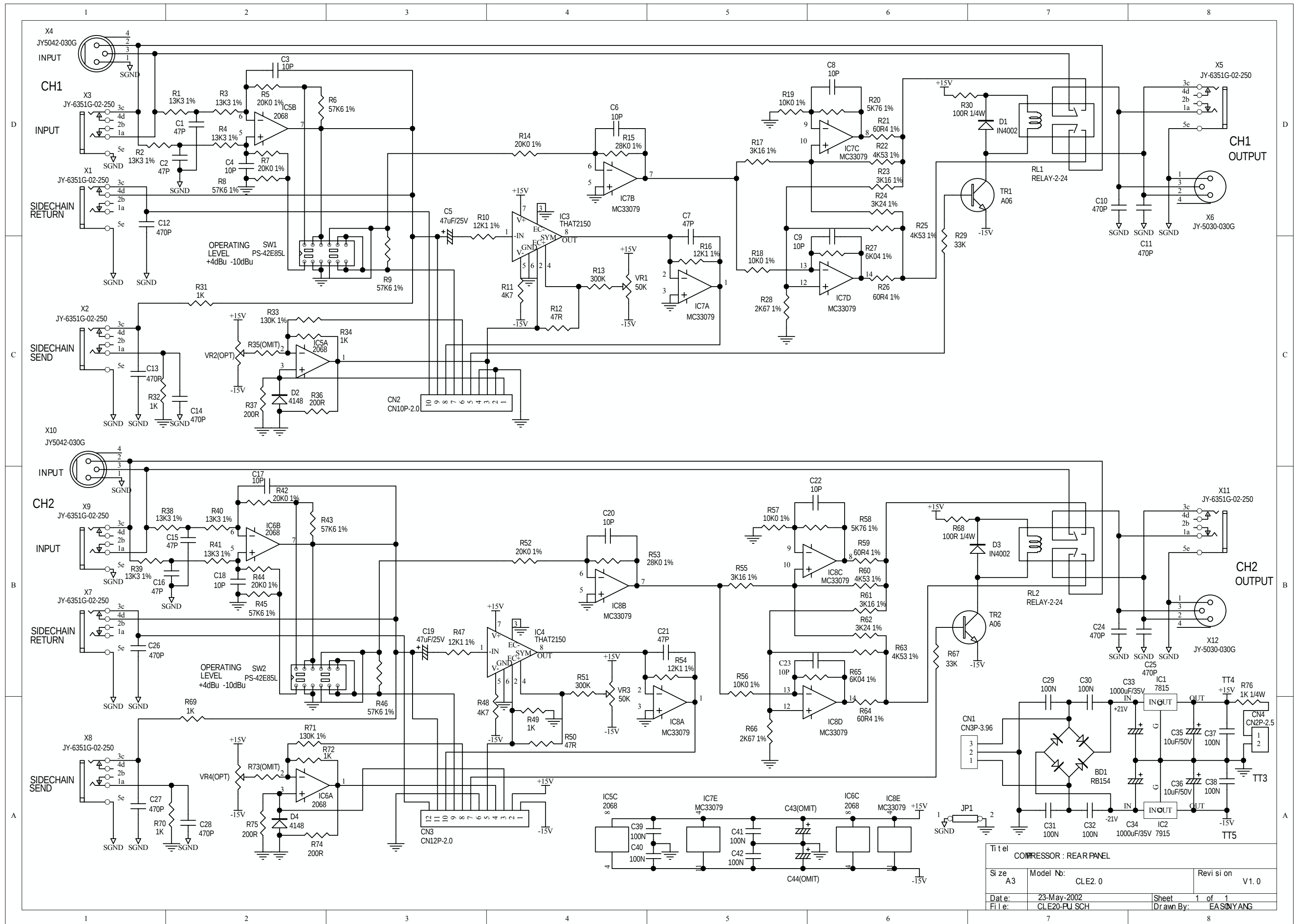

Title: COMPRESSOR : REAR PANEL		
Size: A3	Model No: CLE2.0	Revision: V1.0
Date: 23-May-2002	Sheet: 1 of 1	
File: CLE20-FU SCH	Drawn By: EASOYANG	

4. Printed Circuit Board

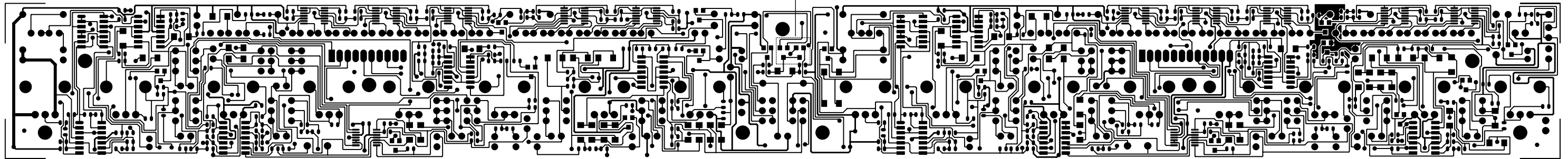

PCB : CLE20-FP Top Layer

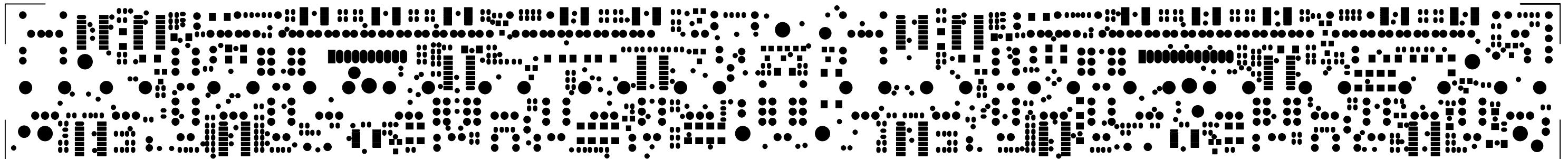

PCB : CLE20-FP Top Solder Mask

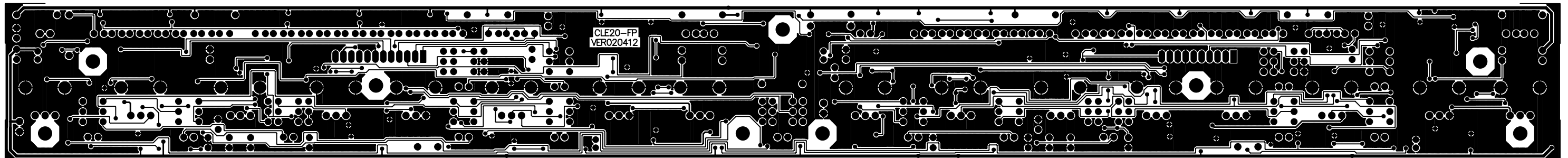

PCB : CLE20-FP Bottom Layer

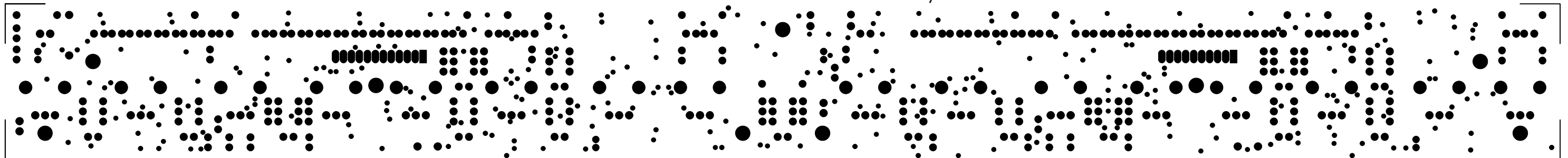

PCB : CLE20-FP Bottom Solder Mask

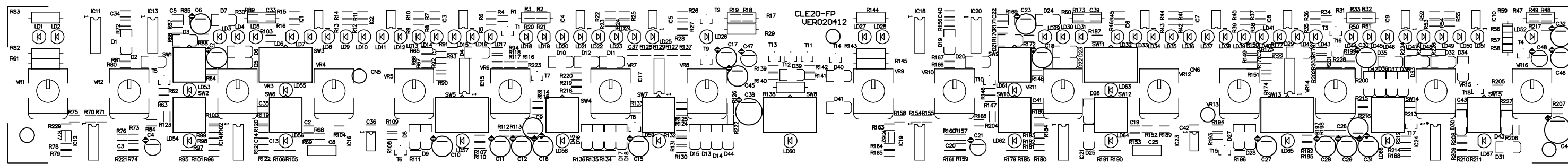

PCB : CLE20-FP Top Overlay

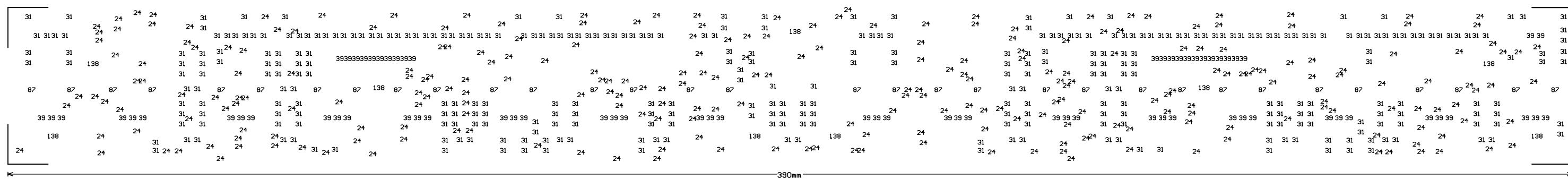

PCB : CLE20-FP Drill Drawing Plots

Hole Size	Hole Count
24mil (0.6mm)	261
31mil (0.8mm)	338
39mil (1.0mm)	72
87mil (2.2mm)	32
138mil (3.5mm)	9
Total	712

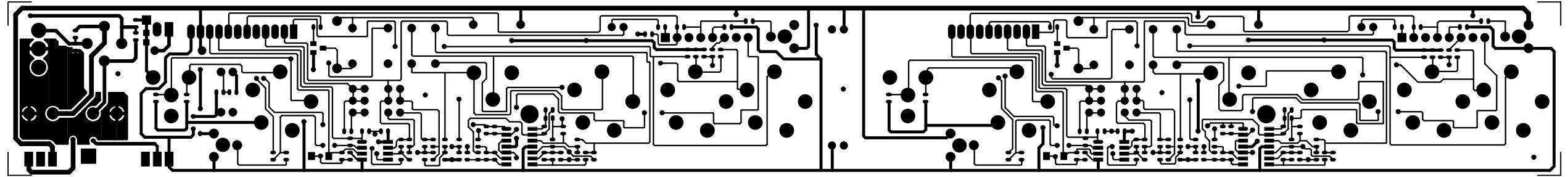

PCB : CLE20-PU Top Layer

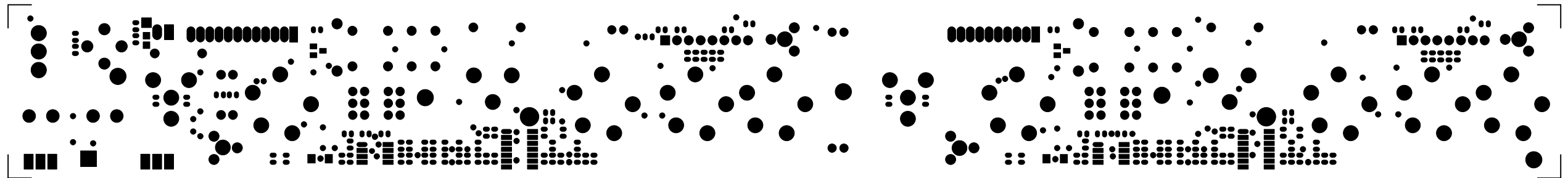

PCB : CLE20-PU Top Solder Mask

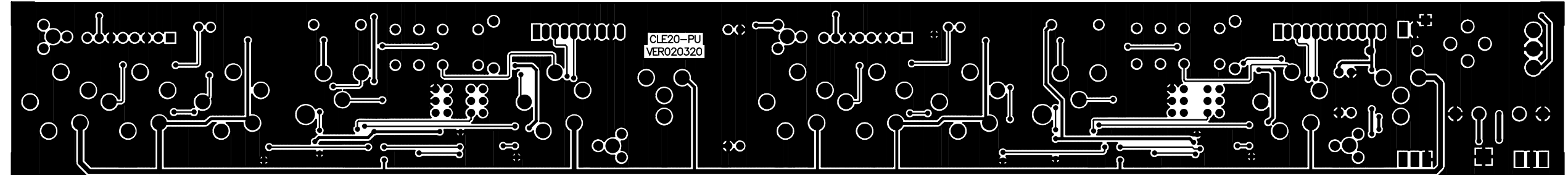

PCB : CLE20-PU Bottom Layer

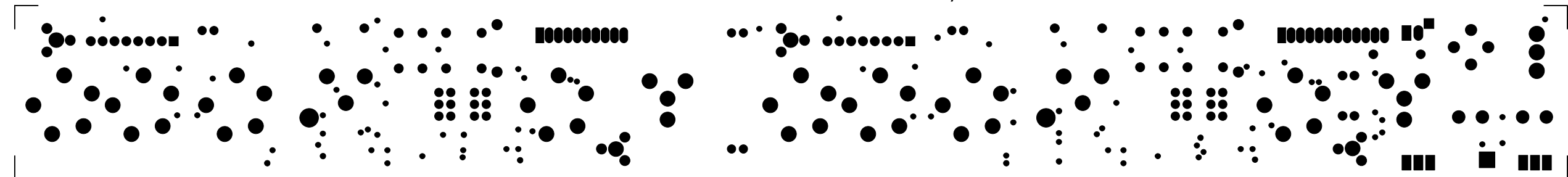

PCB : CLE20-PU Bottom Solder Mask

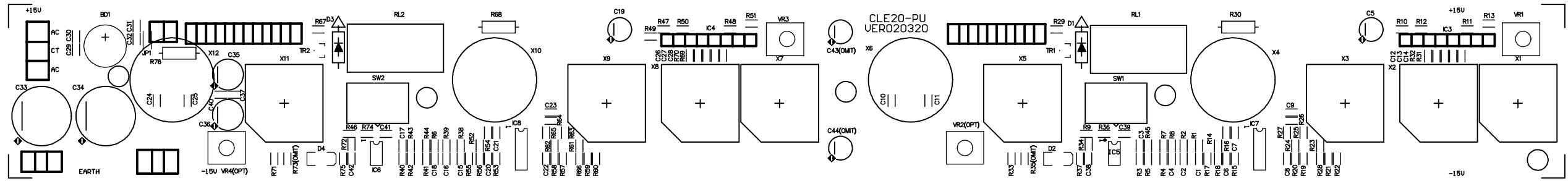

PCB : CLE20-PU Top Overlay

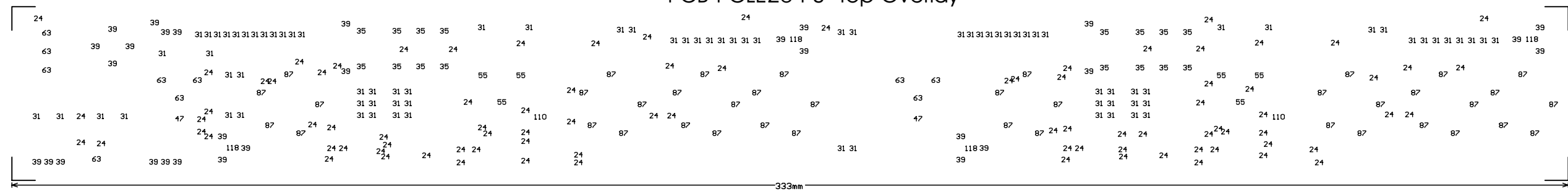

PCB : CLE20-PU Drill Drawing Plots

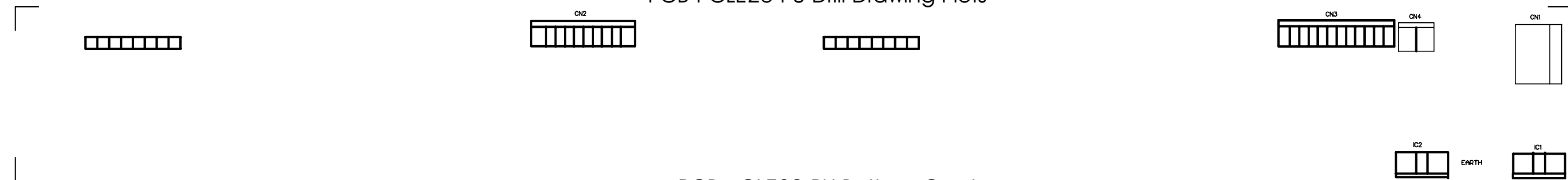

PCB : CLE20-PU Bottom Overlay

Hole Size	Hole Count
24mil (0.6mm)	89
31mil (0.8mm)	84
35mil (0.9mm)	16
39mil (1.0mm)	29
47mil (1.2mm)	2
55mil (1.4mm)	6
63mil (1.6mm)	10
87mil (2.2mm)	40
110mil (2.8mm)	2
118mil (3.0mm)	4
Totals	282

NPTH

5. Wiring Diagram

CLE2.0全機配線圖

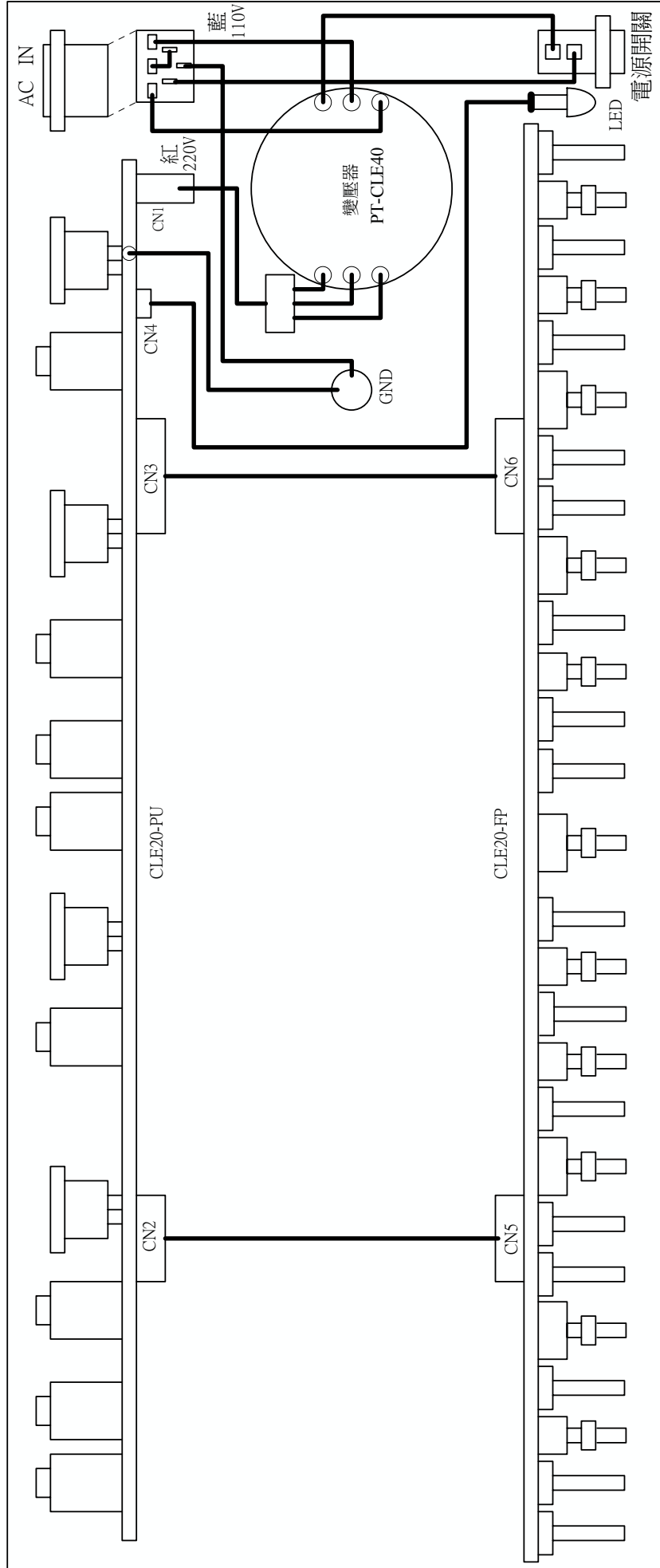

Title		COMPRESSOR CLE2.0	
Size	A4	Model No:	CLE2.0
Date:	6-Feb-2002	Revision	V1.0
File:	CLE-20.Sch	Sheet	of
		Drawn By:	RICK YANG

7. Electrical Parts List

CLE2.0-ALTO-歐洲-230V

Page 1 of 1
2002/9/4

Structure Needing Material Detail List

建檔日: 2002/02/09 修正日: 2002/08/27

NO.	Midprod NO	Quantity	Unit
1	A-CLE2.0-ALTO-歐洲-230V	1.000	PCS
2	A-CLE2.0 前板組合	1.000	PCS
3	A-CLE2.0 底后板組合	1.000	PCS
4	P-CLE20-FP-SMD	1.000	PCS
5	P-CLE20-FP-DIP	1.000	PCS
6	P-CLE20-PU-SMD	1.000	PCS
7	P-CLE20-PU-DIP	1.000	PCS

Item No: CLE2.0

specify: AMP

Mid No: standard quantity:

NO	Material No	Item Name	Specific	Quantity	Unit	Ps
	1 MFR2158ZZ	panel(white)	CLE2.0	1.000	PCS	
MARK:	2 MBK246ZZ	rear board (spray black-	CLE2.0	1.000	PCS	
MARK:	3 MTP229ZZ	top cover-printing	CLE2.0	1.000	PCS	
MARK:	4 NI01862		5.5*5.5*14.5	2.000	PCS	
MARK:	5 NI01863		φ 5.5*W10*6	2.000	PCS	
MARK:	6 NPL275	push putton	φ 3*W6*18.3	15.000	PCS	
MARK:	7 NPL324	LED spacer support	φ 3.1*80.5	2.000	PCS	
MARK:	8 NPL325	LED spacer support	φ 3.1*85	2.000	PCS	
MARK:	9 NMBP64	plastic knob double φ1	COOL GRAY 8C	16.000	PCS	
MARK:	10 NPL272	cover	φ 8.5*4 blue 072C	16.000	PCS	
MARK:	11 HCSA16	AC outlett	(S)315-B (AC select)	1.000	PCS	
MARK:	12 HD00023	fuse(T)	200mA 250V φ 5.2*20mm CS	1.000	PCS	
MARK:	13 NMBA02	power push button	φ 15*17	1.000	PCS	
MARK:	14 NPL285	switch cap	φ 6*2.5 YELLOW C	1.000	PCS	
MARK:	15 HSWA13	alimentation SW	SDDL B 1007U	1.000	PCS	
MARK:	16 DL43RG	L.E.D	LG2043 green	1.000	PCS	
MARK:	17 MSCB34	black plated screw	pill 3*6	2.000	PCS	電池開關
MARK:	18 MSCN19	Ni screw	pill 3*8	2.000	PCS	穩壓晶體
MARK:	19 MSCB13	black-plated screw	cross-head pan head 3*6	15.000	PCS	上蓋,后板,散熱
MARK:	20 MSCB35	black plated screw	cross-head pan head 3*10	2.000	PCS	AC座
MARK:	21 MSCB38	black plated screw	3*7	4.000	PCS	
MARK:	22 MFSC02	washer	φ 4* φ 12*1t	1.000	PCS	
MARK:	23 MFSS04	washer	φ 4* φ 7*1t	2.000	PCS	
MARK:	24 MSCB58	black plated screw	iron-board pill 3*10	8.000	PCS	平衡座用
MARK:	25 NPL267			9.000	PCS	
MARK:	26 MSCC40	colour screw	pill 4*30	1.000	PCS	環形PT
MARK:						

Item No: CLE2.0

specify: AMP

Mid No: standard quantity:

NO	Material No	Item Name	Specific	Quantity	Unit	Ps
	27 NLXC07	rubber coil	φ 20* φ 60*2tB	1.000	PCS	環形PT
MARK:						
	28 MSTC04	colour nut	4m/m	2.000	PCS	環形PT與地線戶
MARK:						
	29 ME00060	MIC stand nut	JY-6351G-02-250	8.000	PCS	
MARK:						
	30 MF00061	mic stand washer	JY-6351G-02-250	8.000	PCS	
MARK:						
	31 MFST01	washer	φ 4* φ 8*0.5t	2.000	PCS	地線用
MARK:						
	32 HLSF94	row-wire connector wirin	2P 280m/m	1.000	PCS	
MARK:						
	33 HLSP164	P.V.C wiring	UL1617 AWG22 250mm black	1.000	PCS	
MARK:						
	34 HLSP71	P.V.C single wave wired	UL1617 22AWG 80m/m brown	1.000	PCS	
MARK:						
	35 HLSC76	single terminal wiring	C green/yellow 150m/m	2.000	PCS	
MARK:						
	36 HLSA31	power cord	Europe 3P LT-312+LT-501	1.000	PCS	
MARK:						
	37 NMCT16WW0010	sleeving flame retardant	2.5 φ *10m/m	2.000	PCS	
MARK:						
	38 NMCT19WW0020	sleeving flame retardant	4 φ *20m/m	8.000	PCS	
MARK:						
	39 MHLB15ZZ	heat-sink	65*18*4 SCX-P234	1.000	PCS	
MARK:						
	40 STR802-T2	silicone insulator	TO-220 square type	2.000		
MARK:						
	41 NPL029	insulate bean	TO220B	2.000	PCS	
MARK:						
	42 NPL278	LED separating pillar	7.6*4.5*184	2.000	PCS	
MARK:						
	43 NMCR01	cable tie(black)	ALT-102SB	3.000	PCS	
MARK:						
	44 NLXM39	self-paste foot pad(SF-0	12.7*9.0*3.0t	4.000	PCS	
MARK:						
	45 NWCP04	lockable bag	5*7	1.000	PCS	
MARK:						
	46 NWCP01WW0300*0580	PE bag	30*58cm	1.000	PCS	
MARK:						
	47 HEM083	desiccant	30g	1.000		
MARK:						
	48 NMLZ779	label	SCL-2020 black/white	1.000		
MARK:						
	49 NMLB1578-01ZZ	label	CLE2.0 ALTO	2.000		
MARK:						
	50 NMCQA-259	instruction English	CLE2.0 ALTO	1.000		
MARK:						
	51 NB01720	box	ALTO 19"系列	1.000	PCS	
MARK:						
	52 PKMS153	sponge barrier	ALTO 19"	1.000	PCS	
MARK:						

Item No: CLE2.0

specify: AMP

Mid No: standard quantity:

<i>NO</i>	<i>Material No</i>	<i>Item Name</i>	<i>Specific</i>	<i>Quantity Unit</i>	<i>Ps</i>
53	PKMS156	barrier	ALTO19"	1.000 PCS	
MARK:					
54	POA182	paper outter case 4 hole	ALTO 19"	0.250 PCS	
MARK:					
55	NMCQ-073	assurance book	ALTO	1.000	
MARK:					
56	TP4042	loop transformer	PT-CLE40	1.000 PCS	
MARK:					
57	NMLM383ZZ	label	CLE2.0	4.000	
MARK:					
58	NE05004	label	ALTO	4.000	
MARK:					
59	NMLH31	label	MADE IN P.R.C.	2.000	
MARK:					
60	NA00154	box	ALTO	2.000 PCS	
MARK:					
61	SIC719	integrated circuit	7915	1.000 PCS	
MARK:					
62	SIC717	integrated circuit	7815	1.000 PCS	
MARK:					
63	NI02085	power switch	φ 22*9.69	1.000 PCS	
MARK:					

Item No: CLE2.0

specify: AMP

Mid No: standard quantity:

NO	Material No	Item Name	Specific	Quantity Unit	Ps
	1 MSDF37ZZ	front board	CLE2.0	1.000 PCS	
MARK:					
	2 MMC013	iron pillar	hexagon 6.35*M3*6	9.000 PCS	
MARK:					

Item No: CLE2.0

specify: AMP

Mid No: standard quantity:

NO	Material No	Item Name	Specific	Quantity	Unit	Ps
1	MBT2103ZZ	bottom rear plate	CLE2.0	1.000	PCS	
MARK:						
2	MSC023	screw pillar	M4*10*0.7PH	1.000	PCS	
MARK:						
3	MAPR80ZZ	L-shape fixed bracket	1.2*28*20*10(CLE2.0)	1.000	PCS	
MARK:						

Item No: CLE2.0

specify: AMP

Mid No: standard quantity:

NO	Material No	Item Name	Specific	Quantity	Unit	Ps
1	NPC2060	PCB-FR4-2L	CLE20-FP(1*4)_VER020412	1.000	PCS	
MARK:						
2	RPCA0402	SMD 1/10W	precise resis 402Ω ±1% 0603	2.000	PCS	
MARK: R 23 53						
3	RPCA0475	SMD 1/10W	precise resis 475Ω ±1% 0603	2.000	PCS	
MARK: R 118 203						
4	RPCA0806	SMD 1/10W	precise resis 806Ω ±1% 0603	2.000	PCS	
MARK: R 24 54						
5	RPCA1150	SMD 1/10W	precise resis 1.50KΩ ±1% 0603	2.000	PCS	
MARK: R 148 64						
6	RPCA1158	SMD 1/10W	precise resis 1.58KΩ ±1% 0603	2.000	PCS	
MARK: R 25 55						
7	RD00285	resistor	3.24KΩ ±1% 0603	2.000	PCS	
MARK: R 26 56						
8	RPCA1499	SMD 1/10W	precise resist 4.99KΩ ±1% 0603	2.000	PCS	
MARK: R 161 221						
9	RD00287	resistor	6.34KΩ ±1% 0603	2.000	PCS	
MARK: R 27 57						
10	RD00366	resistor	7.15KΩ ±1% 0603	2.000	PCS	
MARK: R 178 94						
11	RPCA1806	SMD 1/10W	precise resis 8.06KΩ ±1% 0603	2.000	PCS	
MARK: R 28 58						
12	RPCA2100	SMD 1/10W	precise resis 10.0KΩ ±1% 0603	4.000	PCS	
MARK: R 165 181 78 97						
13	RPCA2121	SMD 1/10W	precise resis 12.1KΩ ±1% 0603	4.000	PCS	
MARK: R 104 189 223 228						
14	RPCA2174	SMD 1/10W	precise resis 17.4KΩ ±1% 0603	6.000	PCS	
MARK: R 106 117 153 191 202 69						
15	RPCA2249	SMD 1/10W	precise resis 24.9KΩ ±1% 0603	2.000	PCS	
MARK: R 152 68						
16	RPCA3287	SMD 1/10W	precise resis 287KΩ ±1% 0603	2.000	PCS	
MARK: R 102 184						
17	RPCA3412	SMD 1/10W	precise resis 412KΩ ±1% 0603	2.000	PCS	
MARK: R 179 95						
18	RPCA3523	SMD 1/10W	precise resis 523KΩ ±1% 0603	8.000	PCS	
MARK: R 100 127 162 183 186 188 77 99						
19	RFCF000	SMD 1/10W	fixed resistor 0Ω ±5% 0603	2.000	PCS	
MARK: R 163 229						
20	RFCF110	SMD 1/10W	fixed resistor 100Ω ±5% 0603	2.000	PCS	
MARK: R 21 51						
21	RFCF111	SMD 1/10W	fixed resistor 110Ω ±5% 0603	2.000	PCS	
MARK: R 20 50						
22	RFCF120	SMD 1/10W	fixed resistor 200Ω ±5% 0603	6.000	PCS	
MARK: R 110 116 195 201 22 52						
23	RFCF147	SMD 1/10W	fixed resistor 470Ω ±5% 0603	4.000	PCS	
MARK: R 114 126 199 207						
24	RFCF210	SMD 1/10W	fixed resistor 1.0KΩ ±5% 0603	10.000	PCS	
MARK: R 105 151 190 220 226 34 35 4 5 67						

Item No: CLE2.0

specify: AMP

Mid No: standard quantity:

NO	Material No	Item Name	Specific	Quantity	Unit	Ps
25	RFCF215	SMD 1/10W fixed resistor	1.5K Ω \pm 5% 0603	2.000	PCS	
MARK:	R 169 85					
26	RFCF220	SMD 1/10W fixed resistor	2.0K Ω \pm 5% 0603	6.000	PCS	
MARK:	R 123 204 36 37 6 7					
27	RFCF222	SMD 1/10W fixed resistor	2.2K Ω \pm 5% 0603	6.000	PCS	
MARK:	R 135 136 168 215 216 84					
28	RFCF230	SMD 1/10W fixed resistor	3.0K Ω \pm 5% 0603	22.000	PCS	
MARK:	R 10 103 11 12 13 137 14 15 166 187 217 38 39 40 41 42 43 44 45 80 9					
29	RFCF247	SMD 1/10W fixed resistor	4.7K Ω \pm 5% 0603	8.000	PCS	
MARK:	R 107 115 133 177 192 200 213 93					
30	RFCF310	SMD 1/10W fixed resistor	10K Ω \pm 5% 0603	14.000	PCS	
MARK:	R 111 124 157 159 170 175 176 196 205 73 74 86 91 92					
31	RFCF315	SMD 1/10W fixed resistor	15K Ω \pm 5% 0603	6.000	PCS	
MARK:	R 101 146 185 2 32 62					
32	RFCF320	SMD 1/10W fixed resistor	20K Ω \pm 5% 0603	6.000	PCS	
MARK:	R 113 167 174 198 81 90					
33	RFCF330	SMD 1/10W fixed resistor	30K Ω \pm 5% 0603	2.000	PCS	
MARK:	R 18 48					
34	RFCF333	SMD 1/10W fixed resistor	33K Ω \pm 5% 0603	2.000	PCS	
MARK:	R 16 46					
35	RFCF339	SMD 1/10W fixed resistor	39K Ω \pm 5% 0603	8.000	PCS	
MARK:	R 112 147 149 197 3 33 63 65					
36	RFCF347	SMD 1/10W fixed resistor	47K Ω \pm 5% 0603	25.000	PCS	
MARK:	R 108 109 119 128 129 130 131 141 142 154 155 19 193 194 208 209 210 211 218 219 224 225 49 70 71					
37	RFCF410	SMD 1/10W fixed resistor	100K Ω \pm 5% 0603	3.000	PCS	
MARK:	R 139 171 87					
38	RFCF422	SMD 1/10W fixed resistor	220K Ω \pm 5% 0603	3.000	PCS	
MARK:	R 120 182 98					
39	RFCF433	SMD 1/10W fixed resistor	330K Ω \pm 5% 0603	2.000	PCS	
MARK:	R 222 227					
40	RFCF447	SMD 1/10W fixed resistor	470K Ω \pm 5% 0603	2.000	PCS	
MARK:	R 121 122					
41	RD00307	resistor	560K Ω \pm 5% 0603	2.000	PCS	
MARK:	R 125 206					
42	RFCF468	SMD 1/10W fixed resistor	680K Ω \pm 5% 0603	2.000	PCS	
MARK:	R 172 88					
43	RFCF510	SMD 1/10W fixed resistor	1.0M Ω \pm 5% 0603	5.000	PCS	
MARK:	R 134 140 173 214 89					
44	RFCF515	SMD 1/10W fixed resistor	1.5M Ω \pm 5% 0603	2.000	PCS	
MARK:	R 180 96					
45	RFCF522	SMD 1/10W fixed resistor	2.2M Ω \pm 5% 0603	2.000	PCS	
MARK:	R 150 66					
46	RFCF547	SMD 1/10W fixed resistor	4.7M Ω \pm 5% 0603	4.000	PCS	
MARK:	R 132 160 212 76					
47	RD00309	resistor	10M Ω \pm 5% 0603	6.000	PCS	
MARK:	R 156 158 164 72 75 79					

Item No: CLE2.0

specify: AMP

Mid No: standard quantity:

NO	Material No	Item Name	Specific	Quantity	Unit	Ps
48	CCE047B	SMD0603 ceramic capacitor	47PF NPO ±5% -50V	2.000	PCS	
MARK:	C 20 3					
49	CCE233I	SMD0603 ceramic capacitor	0.0033uF X7R ±10% -25V	2.000	PCS	
MARK:	C 22 5					
50	CCE310I	SMD0603 ceramic capacitor	0.01uF X7R ±10% -50V	2.000	PCS	
MARK:	C 24 7					
51	CCE347A	SMD0603 ceramic capacitor	0.047uF X7R ±10% -25V	2.000	PCS	
MARK:	C 19 2					
52	CCE410F	SMD0603 ceramic capacitor	0.1uF Y5V+80 -20%50V	12.000	PCS	
MARK:	C 13 14 33 34 35 36 37 39 40 41 42 43					
53	DRS0005	SMD rectifier diode	RLS4148 0.5A (LL-34)	43.000	PCS	
MARK:	D 1 10 11 12 13 14 15 16 17 18 19 2 20 21 22 23 25 26 27 28 29 3 30 31 32 33 34 35 36 37 38 39 4 40 41 42 43 44 45 5 6 8 9					
54	DZSA027	SMD zener diode (LL-34)	1/2W 2.7V(RLZ5.1B)	2.000	PCS	
MARK:	D 24 7					
55	STRS201	SMD transistor	2SC2412K(R)(MMBT3904LT1)	5.000	PCS	
MARK:	T 14 17 18 8 9					
56	STRS103	SMD transistor	2SA1036K(R)(MMBT3906LT1)	11.000	PCS	
MARK:	T 1 10 13 15 16 2 3 4 5 6 7					
57	SF00039	SMD field effect transistor	MMBFJ112(SOT-23)	2.000	PCS	
MARK:	T 11 12					
58	SICS005	SMD integrated circuit	TL064CDT	10.000	PCS	
MARK:	IC 12 13 14 15 17 19 20 21 22 24					
59	SICS309	SMD integrated circuit	CA3086M96	2.000	PCS	
MARK:	IC 11 18					
60	SICS115	SMD integrated circuit	BA10339FV E2	12.000	PCS	
MARK:	IC 1 10 16 2 23 3 4 5 6 7 8 9					

Item No: CLE2.0

specify: AMP

Mid No: standard quantity:

NO	Material No	Item Name	Specific	Quantity	Unit	Ps
	1 RFB022S	1/4W fixed resistor	22Ω S type	4.000	PCS	
MARK:	R 29 30 59 60					
	2 RFB147S	1/4W fixed resistor	470Ω S type	2.000	PCS	
MARK:	R 145 61					
	3 RFB218S	1/4W fixed resistor	1.8KΩ S type	4.000	PCS	
MARK:	R 1 17 31 47					
	4 RFB247S	1/4W fixed resistor	4.7KΩ S type	1.000	PCS	
MARK:	R 138					
	5 RFB268S	1/4W fixed resistor	6.8KΩ S type	4.000	PCS	
MARK:	R 143 144 82 83					
	6 CE422G	electrotytic capacitor	0.22/50V	4.000	PCS	
MARK:	C 10 16 27 31					
	7 CE433G	electrotytic capacitor	0.33uF/50V φ5*11	2.000	PCS	
MARK:	C 1 18					
	8 CE510S	electrolytic capacitor	1/50V φ4*7	4.000	PCS	
MARK:	C 21 4 47 48					
	9 CE522G	electrolytic capacitor	2.2/50V	6.000	PCS	
MARK:	C 12 16 23 29 6 9					
	10 CE533G	electrolytic capacitor	3.3/50V	2.000	PCS	
MARK:	C 11 28					
	11 CE547J	electrotytic capacitor	4.7uF/100V	4.000	PCS	
MARK:	C 15 17 30 32					
	12 CE647G	electrotytic capacitor	47/50V	4.000	PCS	
MARK:	C 38 44 45 46					
	13 CM422IS	metal-film capacitor(MSC 0.22uF/63V 5% CASE02		2.000	PCS	
MARK:	C 25 8					
	14 DL50RG	L.E.D	LVG2340/A 3φ green	20.000	PCS	
MARK:	LD 1 18 19 20 21 22 27 29 3 44 45 46 47 48 55 58 59 63 66 67					
	15 DL50RR	L.E.D	LI2340/A 3φ red	37.000	PCS	
MARK:	LD 10 11 12 13 14 15 16 17 2 25 26 28 31 32 33 34 35 36 37 38 39 40 41 42 43 5 51 52 53 54 6 60 61 62 7 8 9					
	16 DL50RY	L.E.D	LVY2340/A 3φ yellow	10.000	PCS	
MARK:	LD 23 24 30 4 49 50 56 57 64 65					
	17 RC00211	potentiometer	A20KΩ R0911NOB-V1A203FN	2.000	PCS	
MARK:	VR 16 8					
	18 RC00218	potentiometer	A50KΩ R0911NOB-V1A503FN	4.000	PCS	
MARK:	VR 13 14 5 6					
	19 RC00213	potentiometer	B10KΩ R0911NOB-V1B103FN	2.000	PCS	
MARK:	VR 10 2					
	20 RC00217	potentiometer	B50KΩ R0911NOB-V1B503FN	8.000	PCS	
MARK:	VR 1 11 12 15 3 4 7 9					
	21 NI01772	LED separating pillar	LEDS-7 7mm	11.000	PCS	
MARK:	LD 54 56 57 58 59 60 62 64 65 66 67					
	22 NI01781	LED separating pillar	LEDS-8 8mm	52.000	PCS	
MARK:	LD 1 10 11 12 13 14 15 16 17 18 19 2 20 21 22 23 24 25 26 27 28 29 3 30 31 32 33 34 35 36 37 38 39 4 40 41 42 43 44 45 46 47 48 49 5 50 51 52 6 7 8 9					
	23 NI01831		8.5*4*17 black	4.000	PCS	
MARK:	LD 53 55 61 63					

Item No: CLE2.0

specify: AMP

Mid No: standard quantity:

NO	Material No	Item Name	Specific	Quantity Unit	Ps
24	HI00162	sw	PS-22E8552L(3.3x3.3)	10.000 PCS	
MARK:SW 1 10 12 14 15 2 4 6 7 9					
25	HI00163	SW	PS-42E85L(3.3x3.3)	5.000 PCS	
MARK:SW 11 13 3 5 8					
26	HA02084		10P-10P 220mm	1.000 PCS	
MARK:CN 5					
27	HA02078		12P-12P 220	1.000 PCS	
MARK:CN 6					

Item No: CLE2.0

specify: AMP

Mid No: standard quantity:

NO	Material No	Item Name	Specific	Quantity	Unit	Ps
	1 NPC2061	PCB-FR4-2L	CLE20-PU(1*4)_VER020320	1.000	PCS	
MARK:						
	2 RD00297	resistor	60.4Ω ±1% 0603	4.000	PCS	
MARK:	R 21 26 59 64					
	3 RD00271	SMD 1/10W precise resis	2.67KΩ ±1% 0603	2.000	PCS	
MARK:	R 28 66					
	4 RD00363	resistor	3.16KΩ ±1% 0603	4.000	PCS	
MARK:	R 17 23 55 61					
	5 RD00285	resistor	3.24KΩ ±1% 0603	2.000	PCS	
MARK:	R 24 62					
	6 RD00286	resistor	4.53KΩ ±1% 0603	4.000	PCS	
MARK:	R 22 25 60 63					
	7 RD00299	resistor	5.76KΩ ±1% 0603	2.000	PCS	
MARK:	R 20 58					
	8 RD00300	resistor	6.04KΩ ±1% 0603	2.000	PCS	
MARK:	R 27 65					
	9 RPCA2100	SMD 1/10W precise resis	10.0KΩ ±1% 0603	4.000	PCS	
MARK:	R 18 19 56 57					
	10 RPCA2121	SMD 1/10W precise resis	12.1KΩ ±1% 0603	4.000	PCS	
MARK:	R 10 16 47 54					
	11 RPCA2133	SMD 1/10W precise resis	13.3KΩ ±1% 0603	8.000	PCS	
MARK:	R 1 2 3 38 39 4 40 41					
	12 RPCA2200	SMD 1/10W precise resis	20.0KΩ ±1% 0603	6.000	PCS	
MARK:	R 14 42 44 5 52 7					
	13 RPCA2280	SMD 1/10W precise resis	28.0KΩ ±1% 0603	2.000	PCS	
MARK:	R 15 53					
	14 RPCA2576	SMD 1/10W precise resis	57.6KΩ ±1% 0603	6.000	PCS	
MARK:	R 43 45 46 6 8 9					
	15 RPCA3130	SMD 1/10W precise resis	130KΩ ±1% 0603	2.000	PCS	
MARK:	R 33 71					
	16 RFCF047	SMD 1/10W fixed resistor	47Ω ±5% 0603	2.000	PCS	
MARK:	R 12 50					
	17 RFCF120	SMD 1/10W fixed resistor	200Ω ±5% 0603	4.000	PCS	
MARK:	R 36 37 74 75					
	18 RFCF210	SMD 1/10W fixed resistor	1.0KΩ ±5% 0603	7.000	PCS	
MARK:	R 31 32 34 49 69 70 72					
	19 RFCF247	SMD 1/10W fixed resistor	4.7KΩ ±5% 0603	2.000	PCS	
MARK:	R 11 48					
	20 RFCF333	SMD 1/10W fixed resistor	33KΩ ±5% 0603	2.000	PCS	
MARK:	R 29 67					
	21 RFCF430	SMD 1/10W fixed resistor	300KΩ ±5% 0603	2.000	PCS	
MARK:	R 13 51					
	22 CCE010B	SMD0603 ceramic capacito	10PF NPO ±5% -50V	8.000	PCS	
MARK:	C 17 18 20 22 3 4 6 8					
	23 CCE039B	SMD0603 ceramic capacito	39PF NPO ±5% -50V	2.000	PCS	
MARK:	C 23 9					
	24 CCE047B	SMD0603 ceramic capacito	47PF NPO ±5% -50V	6.000	PCS	
MARK:	C 1 15 16 2 21 7					

Item No: CLE2.0

specify: AMP

Mid No: standard quantity:

NO	Material No	Item Name	Specific	Quantity	Unit	Ps
25	CCE147B	SMD0603 ceramic capacitor	470PF NPO ±5% -50V	10.000	PCS	
MARK:	C 10 11 12 13 14 24 25 26 27 28					
26	CCE410F	SMD0603 ceramic capacitor	0.1uF Y5V+80 -20%50V	10.000	PCS	
MARK:	C 29 30 31 32 37 38 39 40 41 42					
27	DRS0005	SMD rectifier diode	RLS4148 0.5A (LL-34)	2.000	PCS	
MARK:	D 2 4					
28	STRS201	SMD transistor	2SC2412K(R)(MMBT3904LT1)	2.000	PCS	
MARK:	TR 1 2					
29	SICS307	SMD integrated circuit	MC33079DT(ST)MC33079D(ON)	2.000	PCS	
MARK:	IC 7 8					
30	SICS202	SMD integrated circuit	NJM2068M-TE1(LM833D)	2.000	PCS	
MARK:	IC 5 6					

Item No: CLE2.0

specify: AMP

Mid No: standard quantity:

NO	Material No	Item Name	Specific	Quantity	Unit	Ps
	1 RFB110	1/4W fixed resistor	100Ω	2.000	PCS	
MARK:	R 30 68					
	2 RA00212	resistor	1.0KΩ M	1.000	PCS	
MARK:	R 76					
	3 RCB345E	carbon trimmer resistor	6FE horizontal EVND8A 50	2.000	PCS	
MARK:	VR 1 3					
	4 CE610S	electrolytic capacitor	10/50V 6.3*7	2.000	PCS	
MARK:	C 35 36					
	5 CE647E	electrolytic capacitor	47/25V	2.000	PCS	
MARK:	C 19 5					
	6 CE810F	electrolytic capacitor	1000/35V	2.000	PCS	
MARK:	C 33 34					
	7 DR001A	rectifier diode	1N4002/100V	2.000	PCS	
MARK:	D 1 3					
	8 DB001A	bridge rectifier	RB154 1A/400V	1.000	PCS	
MARK:	BD 1					
	9 SIC208	integrated circuit	THAT2150A	2.000	PCS	
MARK:	IC 3 4					
	10 HEM202	raley	GS-SH-224T 24V	2.000	PCS	
MARK:	RL 1 2					
	11 HI00163	SW	PS-42E85L(3.3x3.3)	2.000	PCS	
MARK:	SW 1 2					
	12 HC00392	balance mic socket	JY-5030-030G 公插插板式	2.000	PCS	
MARK:	X 13 6					
	13 HCSM61	MIC jack for balance	JY-5042-030G female plug	2.000	PCS	
MARK:	X 10 4					
	14 HC00125	MIC jack	JY-6351G-02-250	8.000	PCS	
MARK:	X 1 11 2 3 5 7 8 9					
	15 HCSI0202	row-wire header	2P 2.5mm 180°	1.000	PCS	
MARK:	CN 4					
	16 HCSJ0203	row-wire header	3P 3.9mm 180°	1.000	PCS	
MARK:	CN 1					
	17 HCSV0210	row wire header	10P 2.0mm 180°	1.000	PCS	
MARK:	CN 2					
	18 HCSV0212	row-wire header	12P 2.0mm 180°	1.000	PCS	
MARK:	CN 3					

8. Exploded Views

SEKAKU

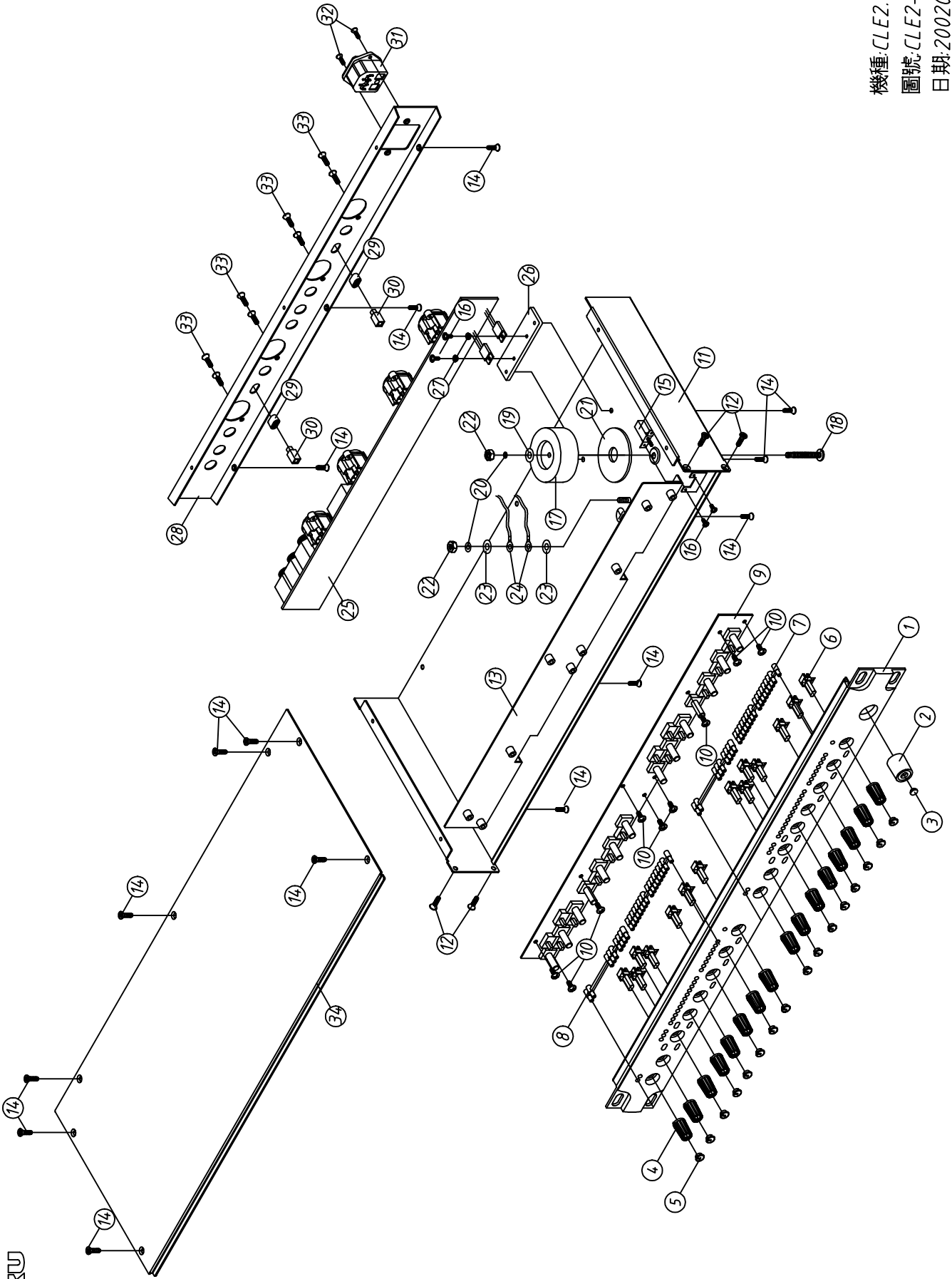

機種: CLE2.0
圖號: CLE2-00
日期: 20020204