

# ***Service Manual***

**MODEL: D1/D2/D3/D4**

# CONTENT

1. INTRODUCTION.....	1
2. TECHNICAL SPECIFICATION.....	2
3. BLOCK DIAGRAM.....	3
4. SCHEMATIC DIAGRAM.....	5
5. WIRING DIAGRAM.....	10
6. PCB LAYOUT.....	12
7. TEST PROCEDURE.....	21
8. EXPLODED VIEW & MECHANICAL PARTS LIST.....	27
9. BOM.....	36

# 1. INTRODUCTION

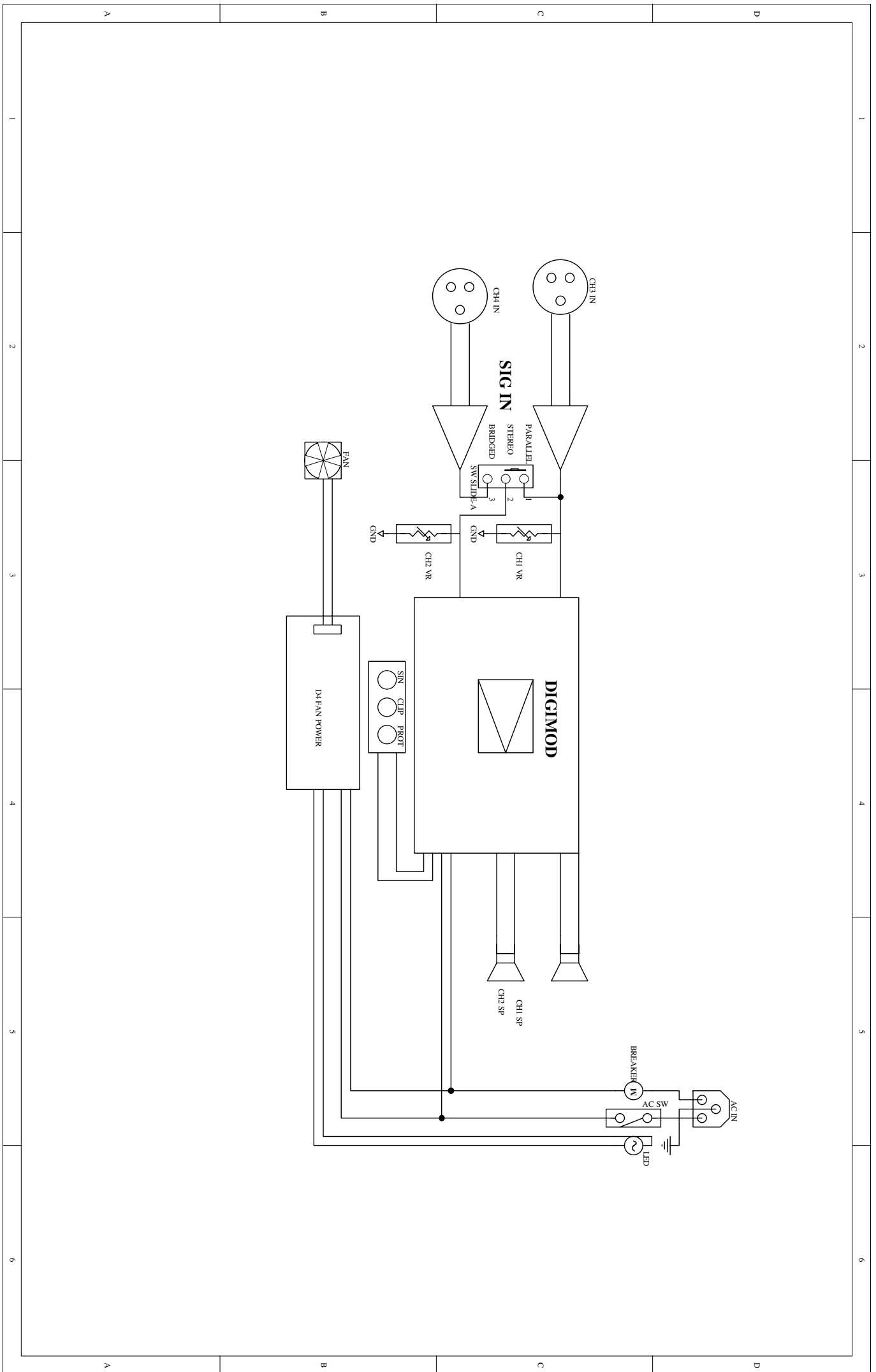
The ▲LTO D series includes D1, D2, D3, D4. It is a line of high power, low profile, professional Power Amplifiers with advanced features and great reliability. They deliver tremendous power in only two rack spaces, providing high level performance under the most demanding conditions. An automatic speed fan matches cooling capacity with heat requirements. The amplifier frame contains all solid-state circuitry, using complementary silicon output devices. The amplifier is supplied with a single moulded AC cord having an appropriate AC plug for the intended operating voltage. The amplifier employs forced air cooling with a variable speed fan for minimum acoustic noise. Air flow is from rear to front to avoid temperature rise inside the Rack. D1, D3 contain two independent channels and D2, D4 contain four independent channels, with separate AC transformer secondaries, power supplies and protection system. All protection systems, except the main AC one, are self resetting upon removal of fault, and the remaining channel shall continue to operate. Each channel has independent protective circuitry against short circuit, over-loads and over temperature, and also has DC protection. Each channel has also LEDs for power-on, signal, clip and protection. Standard power connectors are used for power outputs. Input can be parallel or stereo or bridge and an high quality audio transformer can be added on the input stage of each channel. It provides the following features:

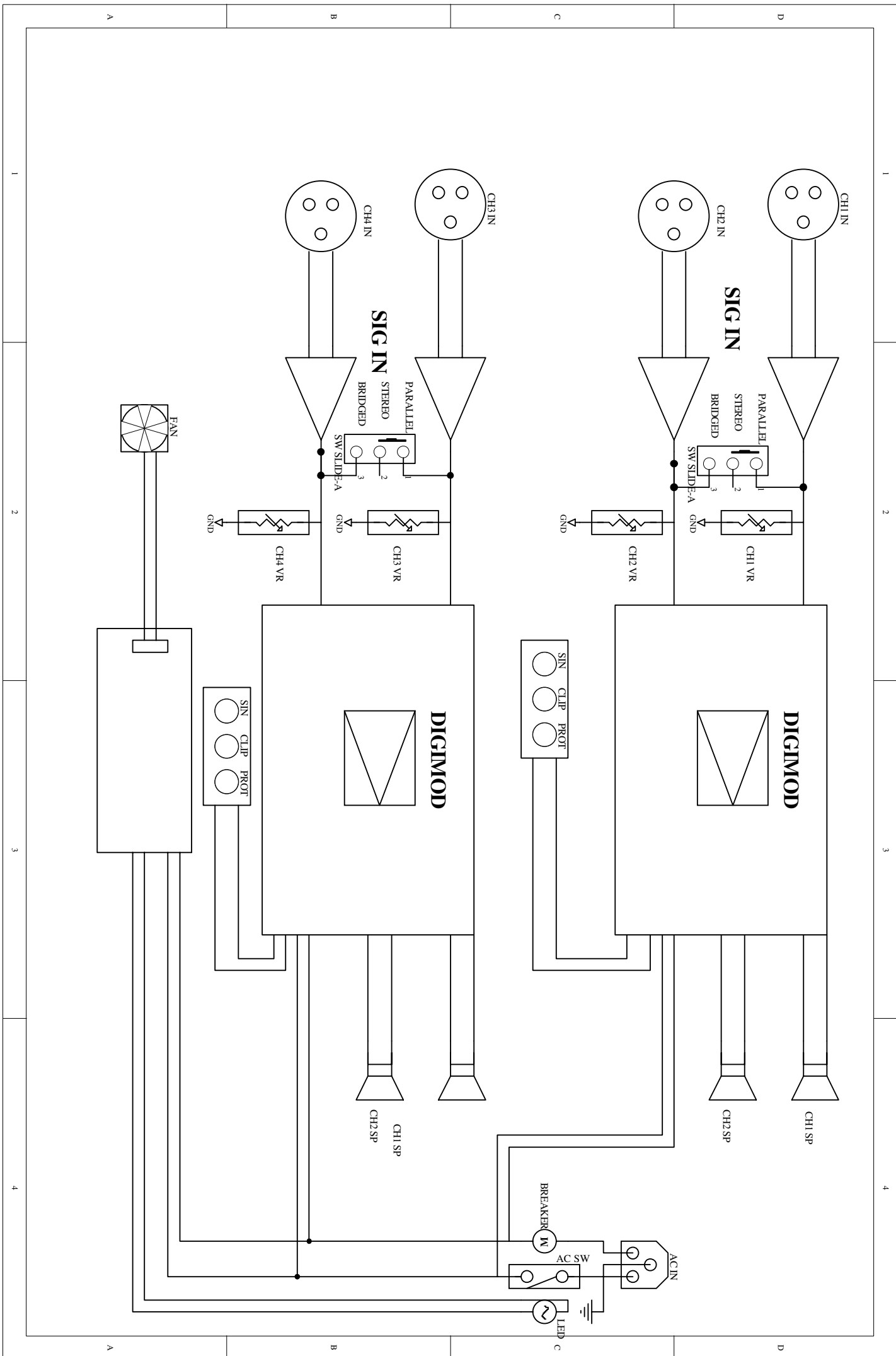
- 2U rack, multi-channel high power amplifier
- Fantastic audio quality even with extremely high volume levels
- Solid and durable, can be mounted into a cabinet
- Automatic limiter
- Stereo (dual-channel), or bridge mono operating modes
- Balanced XLR,  $\phi$  6.3 inputs / parallel outputs to ensure noiseless long wiring
- Binding post and professional speak-on connectors for output
- Stereo, bridge, and parallel output wiring possibility
- Front panel LED indicators for power-on, signal, protection and clip
- Accurate gain control
- Independent DC, thermal, overload and short-circuit protection on each channel automatically protects amplifier and speaker
- Used together with line array cabinet in one audio system
- Class D technology, switch power, light weight and high power
- Manufactured under TS16949, ISO 14001 certified management system and RoHS directive

## 2. TECHNICAL SPECIFICATION

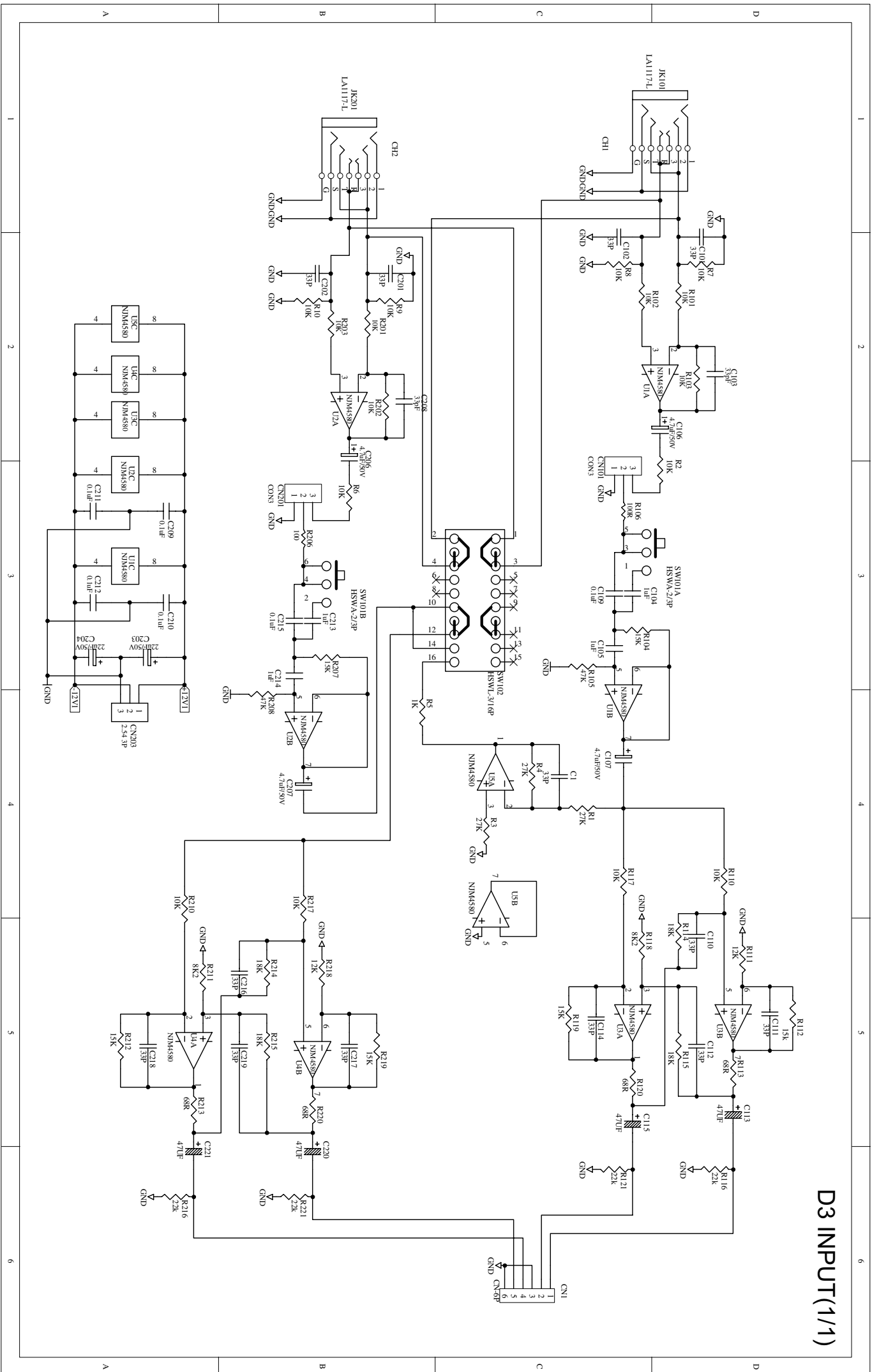
	D1	D2	D3	D4
<b>Output power</b>				
	2CH Amplifier	4CH Amplifier	2CH Amplifier	4CH Amplifier
<b>Power continuous @0.5% THD . Both channels driven, 230V</b>				
8ohms per channel(RMS)	2 X 240W	4 X 240W	2 X 340W	4 X 340W
4ohms per channel(RMS)	2 X 390W	4 X 390W	2 X 540W	4 X 540W
<b>Power EIAJ@1% THD, both channels driven, 230V</b>				
8ohms per channel(EIAJ)	2 X 270W	4 X 270W	2 X 370W	4 X 370W
4ohms per channel(EIAJ)	2 X 500W	4 X 500W	2 X 750W	4 X 750W
<b>BRIDGED MODE</b>				
16ohms (EIAJ)	1 X 520W	2 X 520W	1 X 740W	2 X 740W
8ohms (EIAJ)	1 X 1000W	2 X 1000W	1 X 1500W	2 X 1500W
<b>Distortion(AMPTE-IM)</b>	< 0.5%(THD, DIM, SMPTE)			
<b>Frequency Response</b>	20Hz-20kHz+/-0.1dB, -3dB points: 10Hz - 60kHz			
<b>Damping Factor, at 8 ohms</b>	> 300 at 8ohms			
100Hz	> 500			
1KHz	> 200			
10KHz	> 100			
<b>Signal to Noise, 20Hz -20KHz</b>	> 105dB/A weighted			
<b>Voltage Gain</b>	40 X (32dB)			
<b>Input Sensitivity @ 4ohms</b>	1Vrms			
<b>Input Clipping</b>	10Vrms (+22dB)			
<b>Input Impedance</b>	10k ohms unbalanced, 20k ohms balanced 56(36dB)			
<b>Controls</b>	Front: AC switch, gain knobs			
	Rear: low pass filter, mode selector			
	Power-on: blue			
<b>Indicators (1per channel)</b>	Operation/Protection: red			
	Clip: red			
<b>Cooling</b>	Continuously 7-variable-speed fan, rear- to - front air flow			
<b>Load Protection</b>	On/off muting, DC-fault load grounding relay. Internal fault fuses			
<b>Power Requirements</b>	AC230V,AC115V, 50-60Hz			
<b>Dimensions</b>	19"(483mm) rack mounting, 3.5"(88.8mm) tall (2 rack spaces)			
	11.2"(285mm) deep	14.8"(376mm) deep	11.2"(285mm) deep	14.8"(376mm) deep
<b>Net Weight</b>	5.50Kg	7.90Kg	5.50Kg	7.90Kg

### 3. BLOCK DIAGRAM

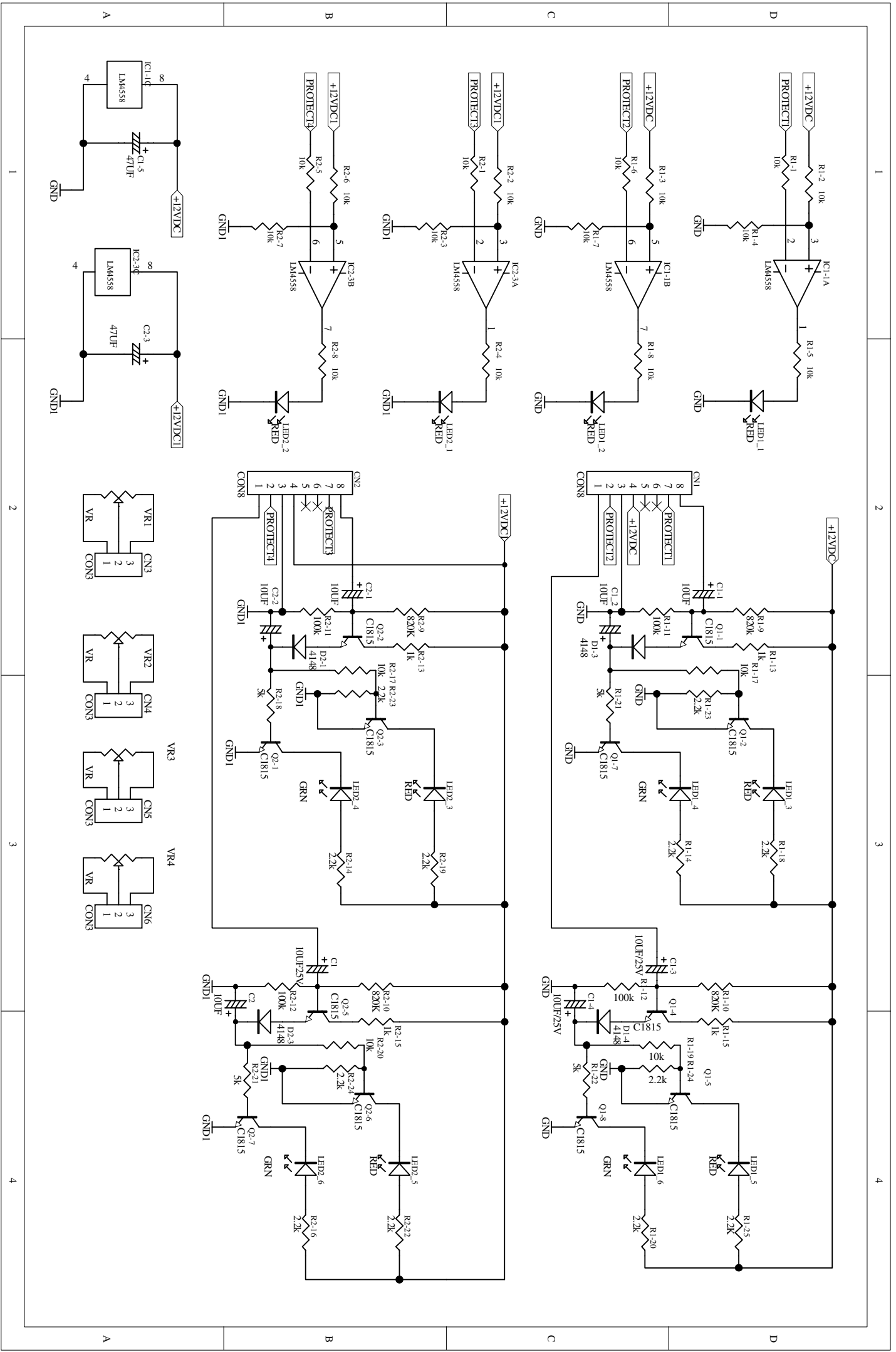




# 4. SCHEMATIC DIAGRAM

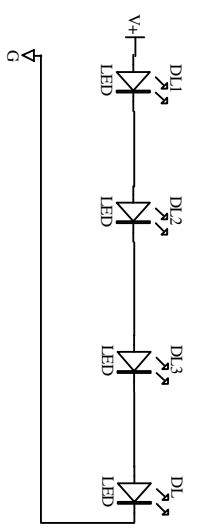


D3 INPUT(1/1)

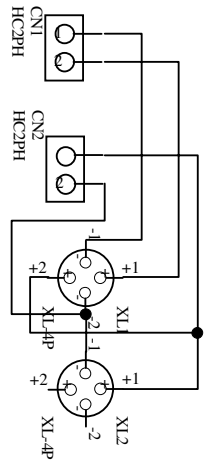




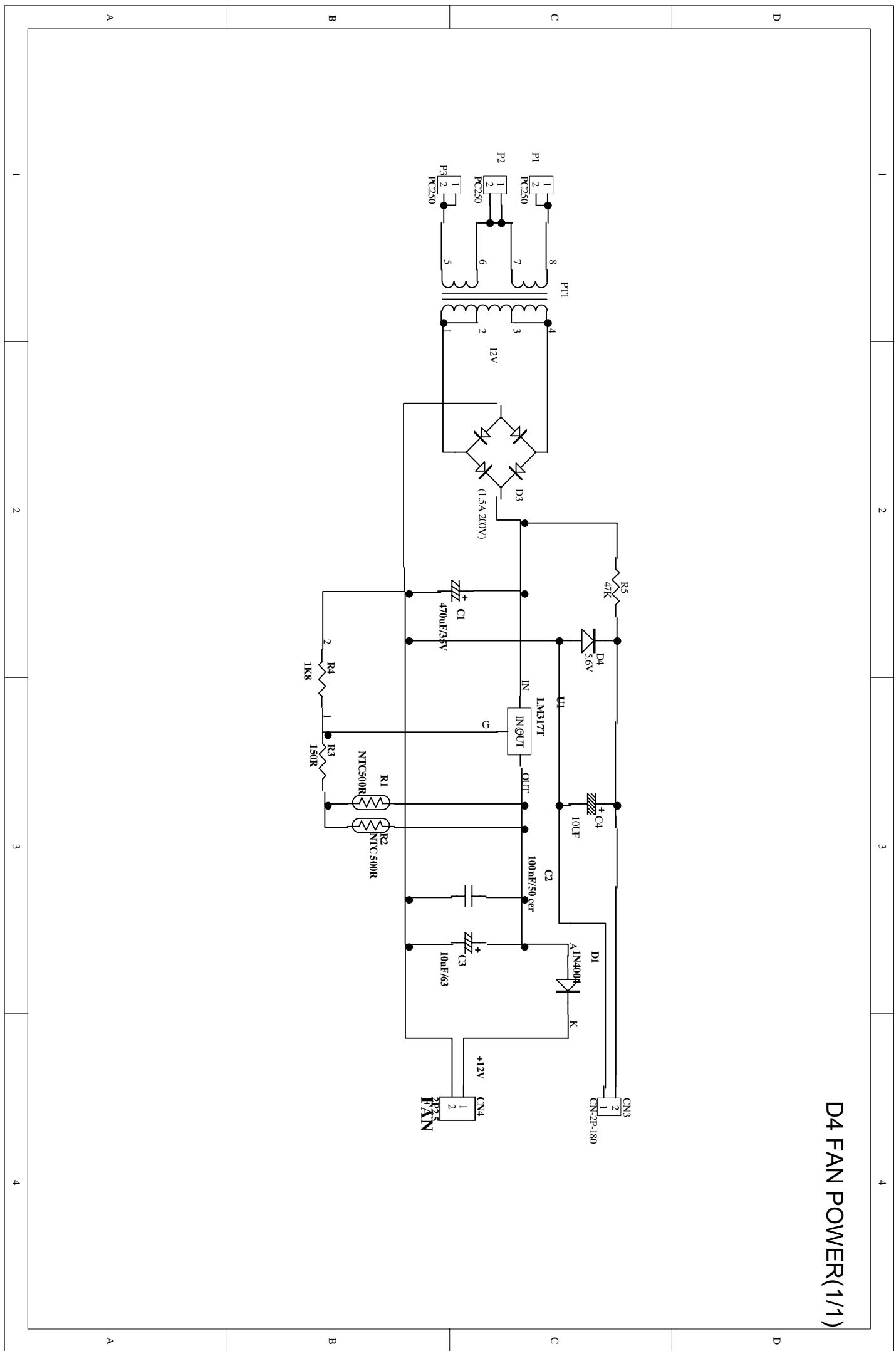
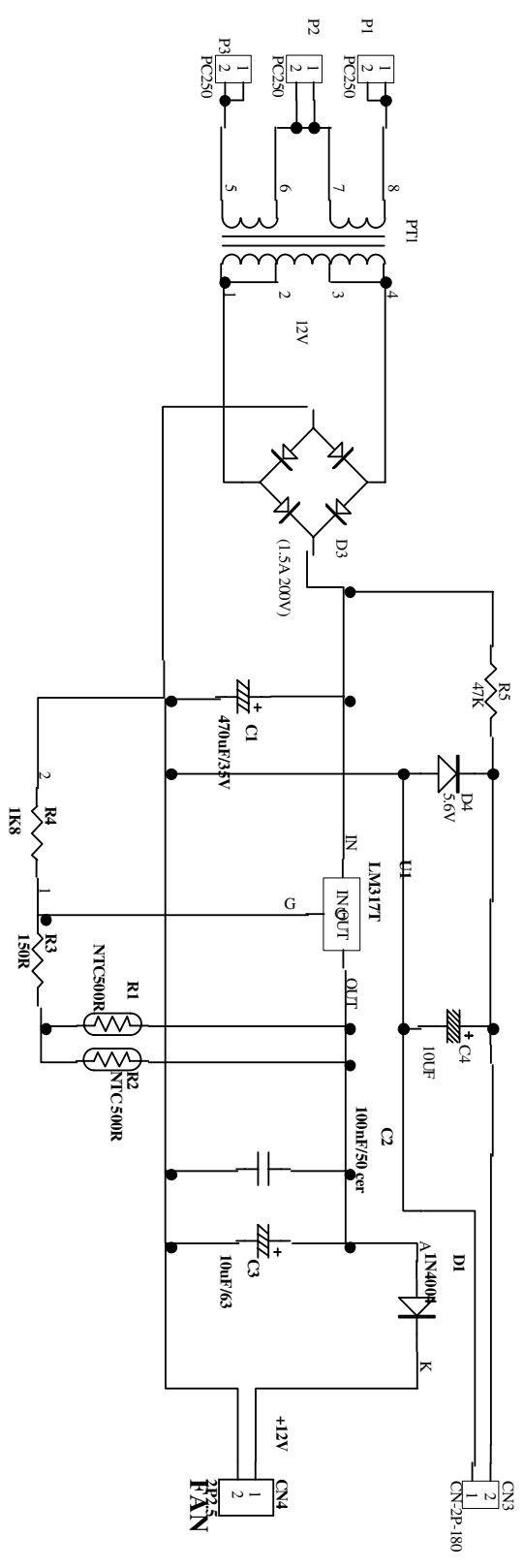
D3-LED(1/1)



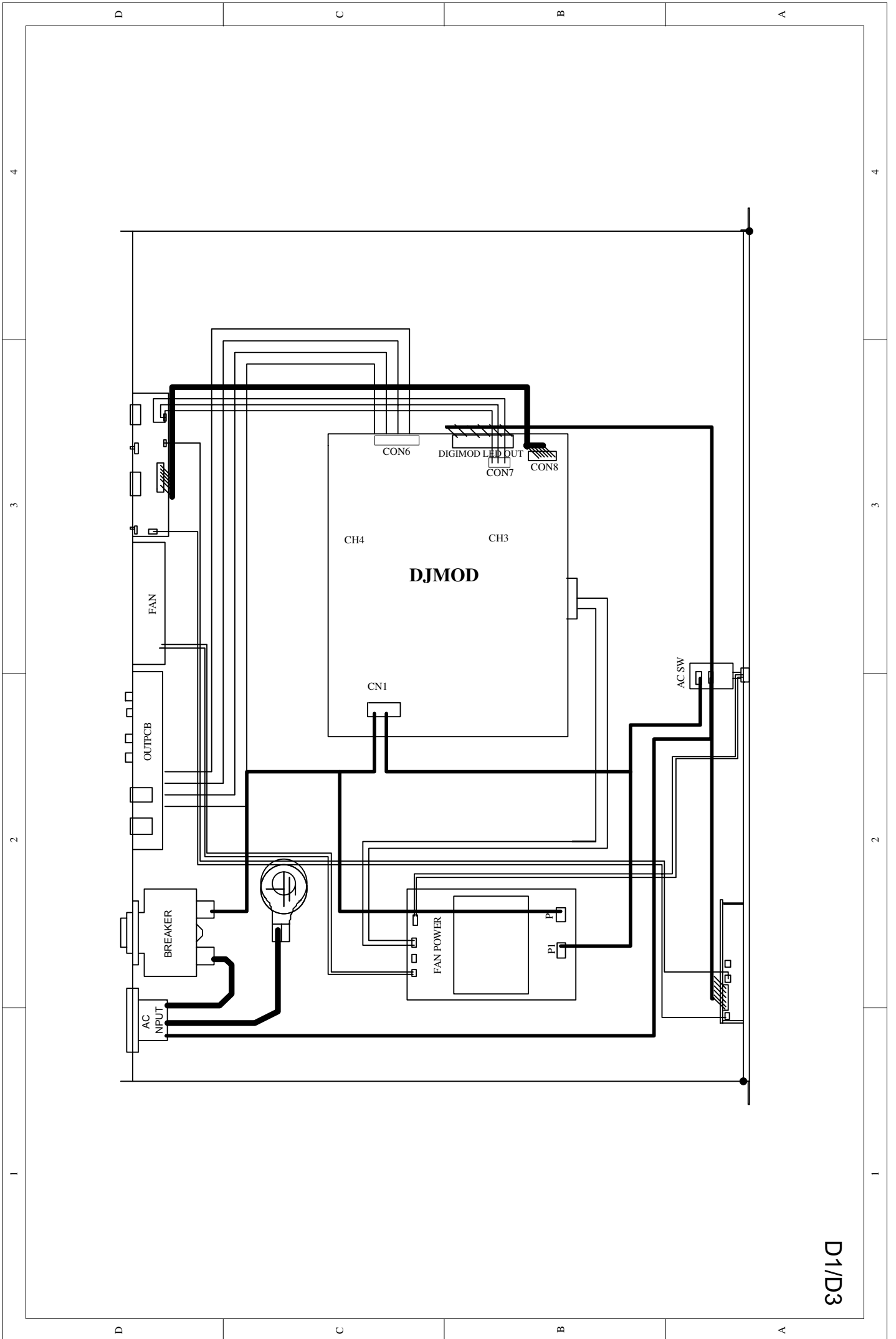
# D4 OUTPUT(1/1)



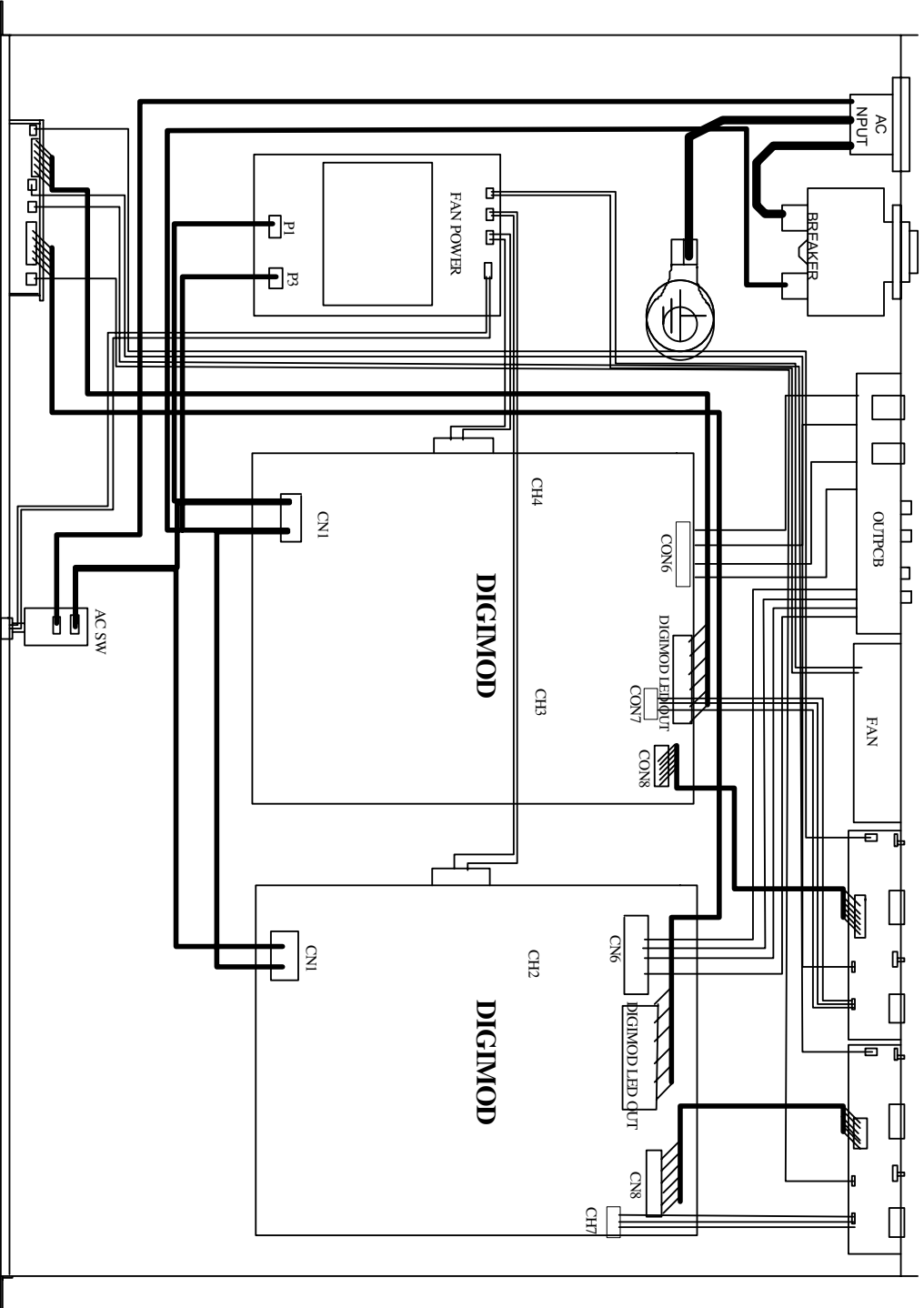
# D4 FAN POWER(1/1)



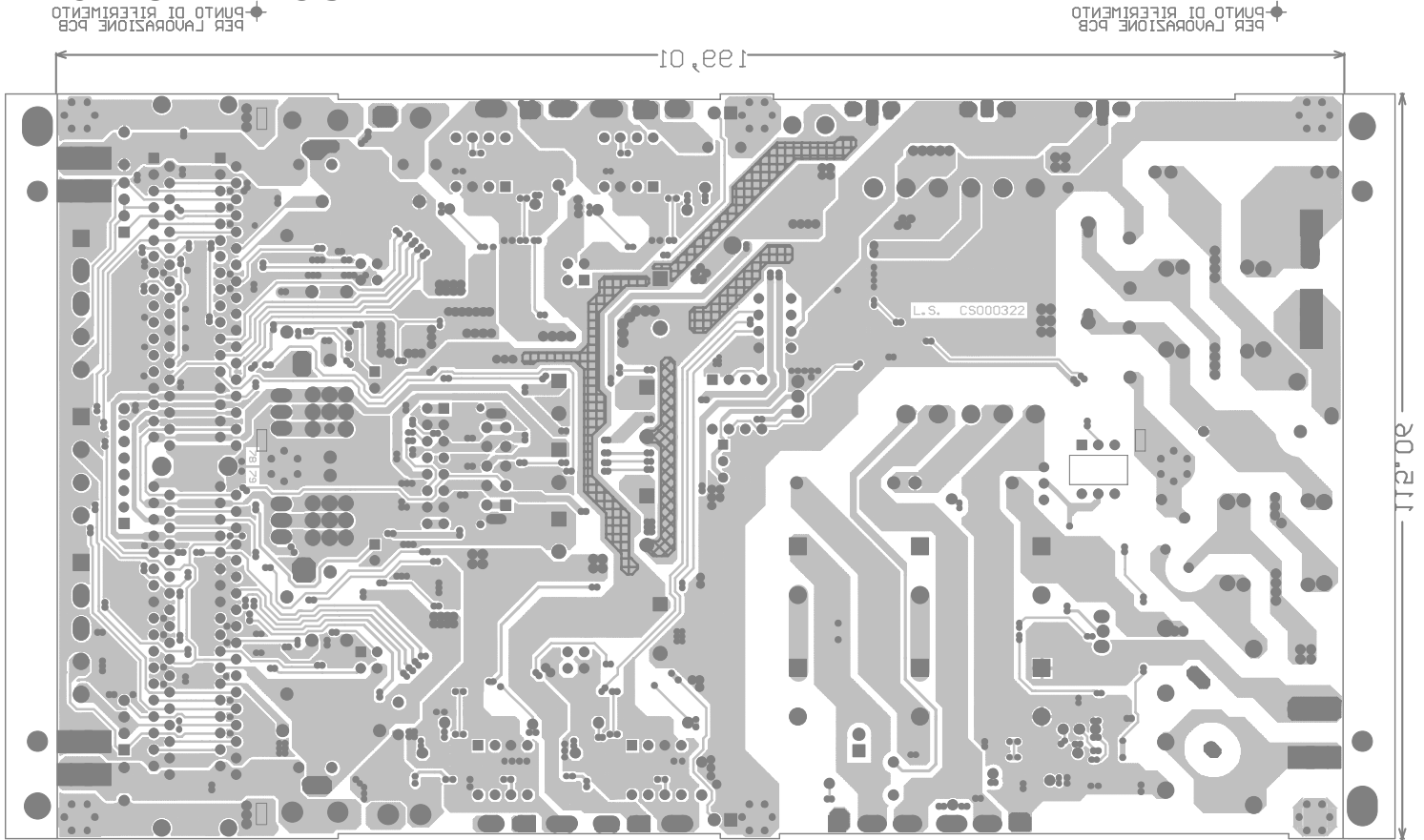
# 5. WIRING DIAGRAM



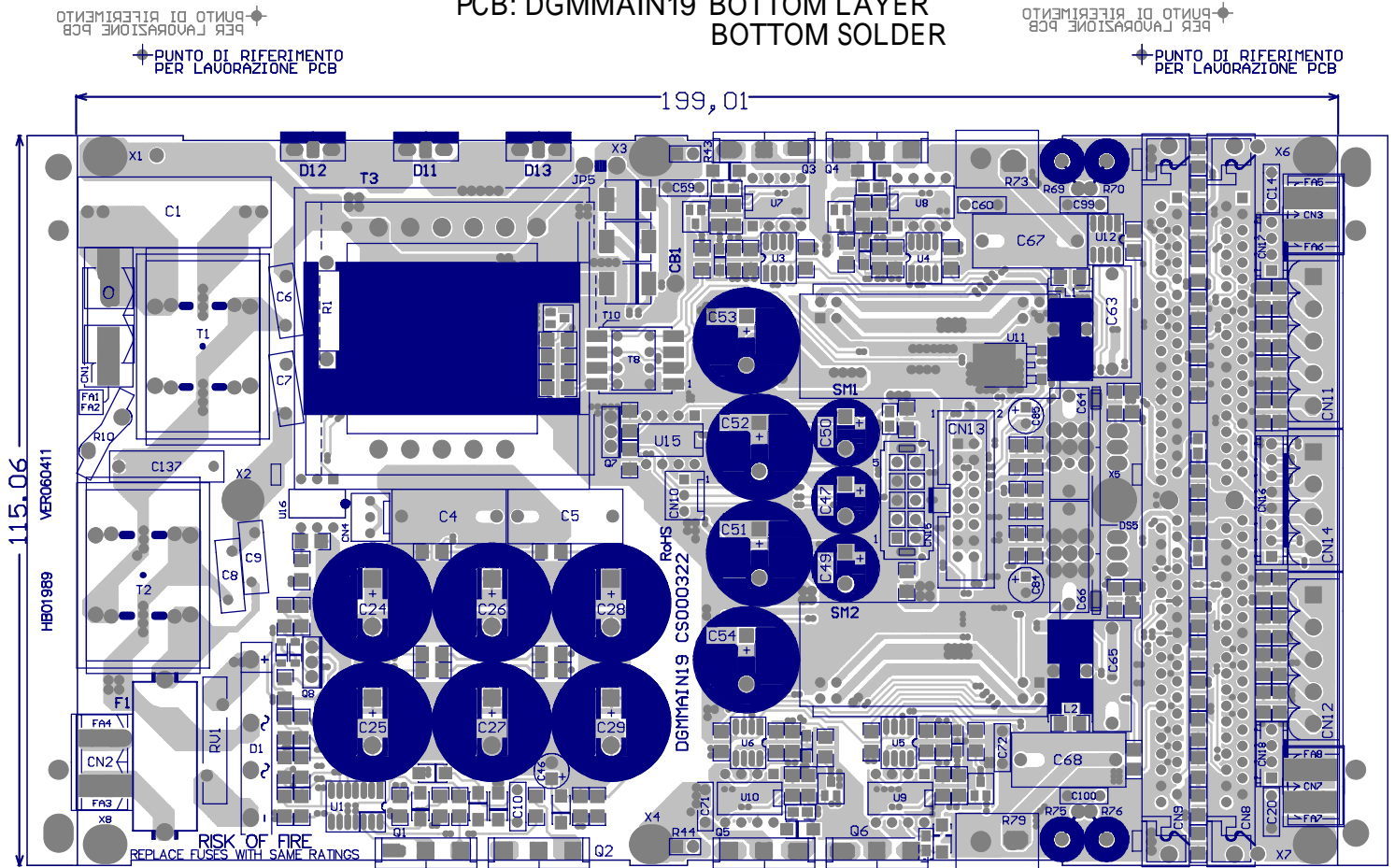
D1/D3



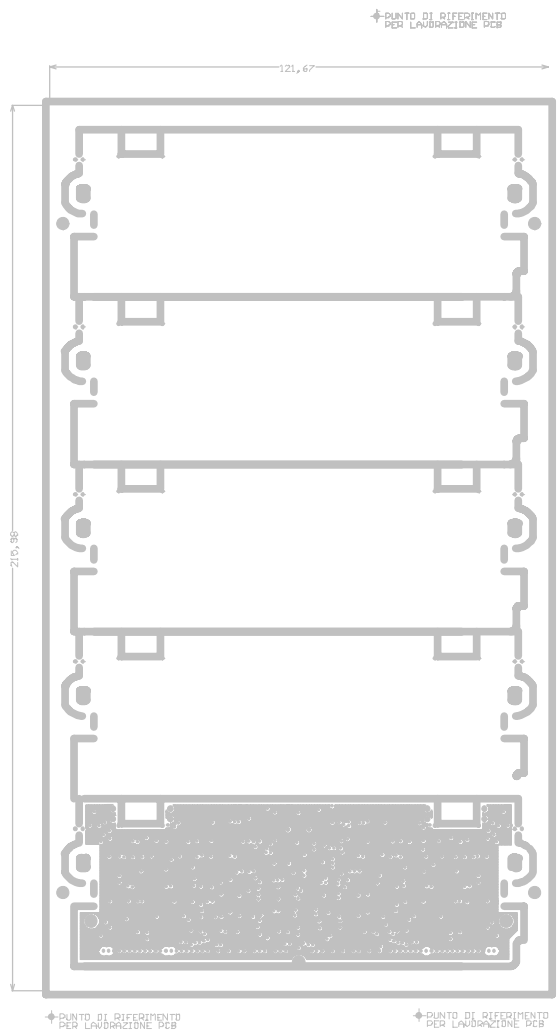
# 6. PCB LAYOUT



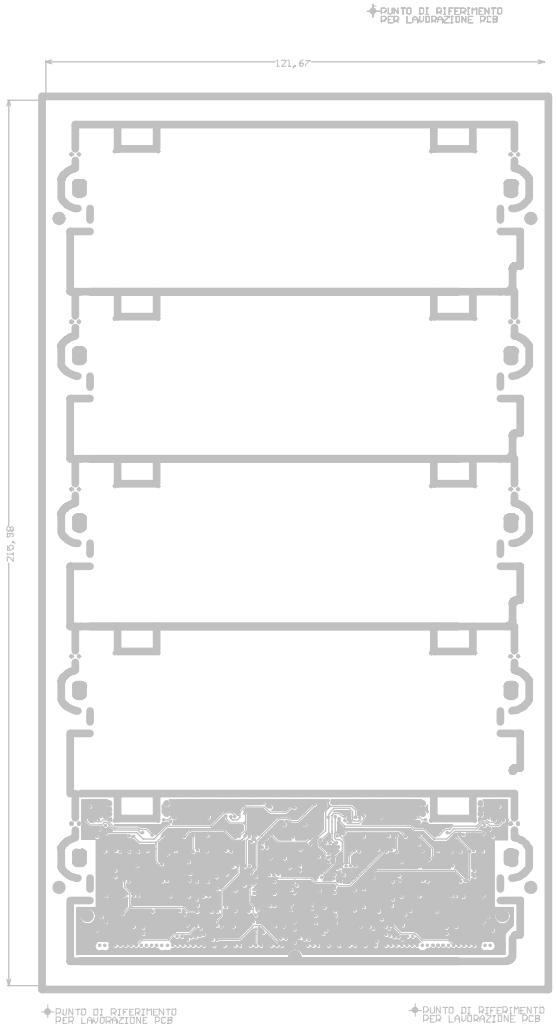
PCB: DGMMAIN19 BOTTOM LAYER  
BOTTOM SOLDER



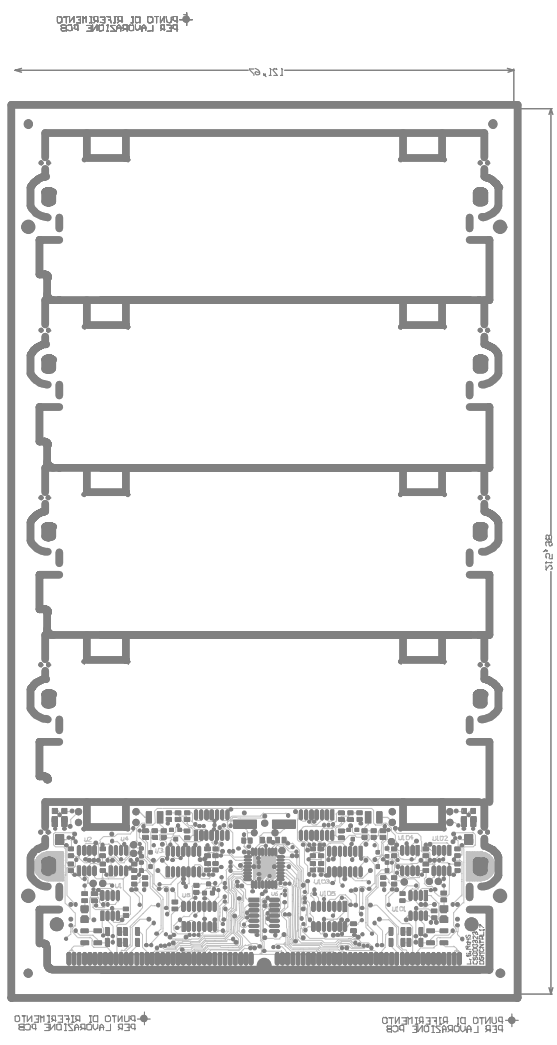
PCB: DGMMAIN19 TOP LAYER  
TOP OVERLAY  
TOP SOLDER



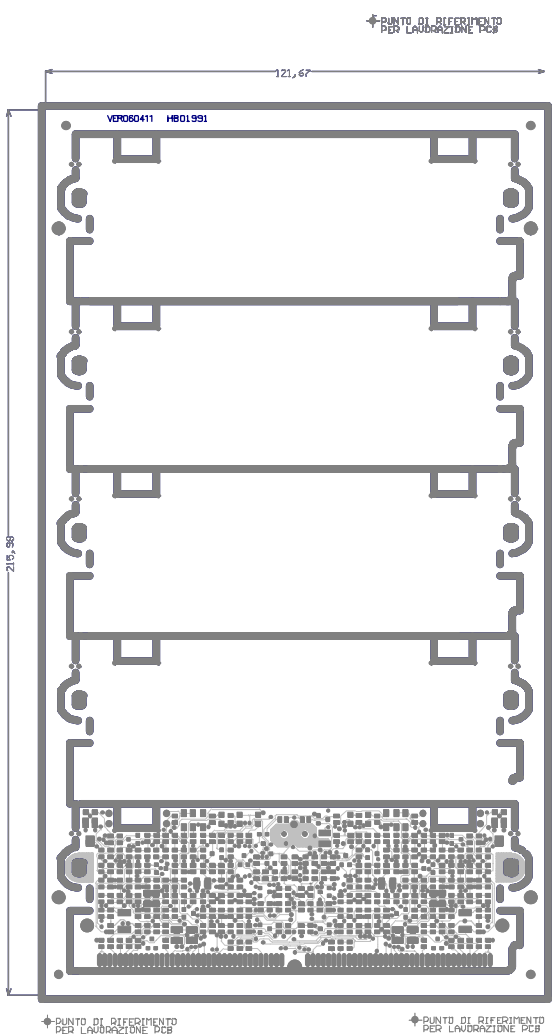
DGMCN  
TRL17  
GND



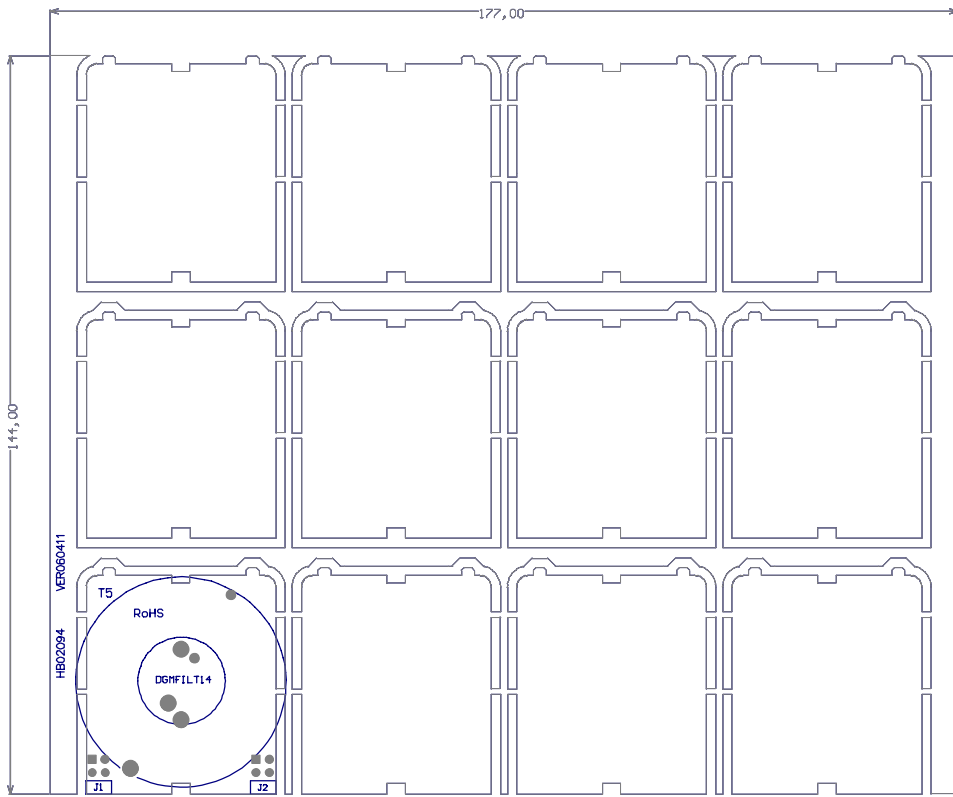
DGMCN  
TRL17  
VCC



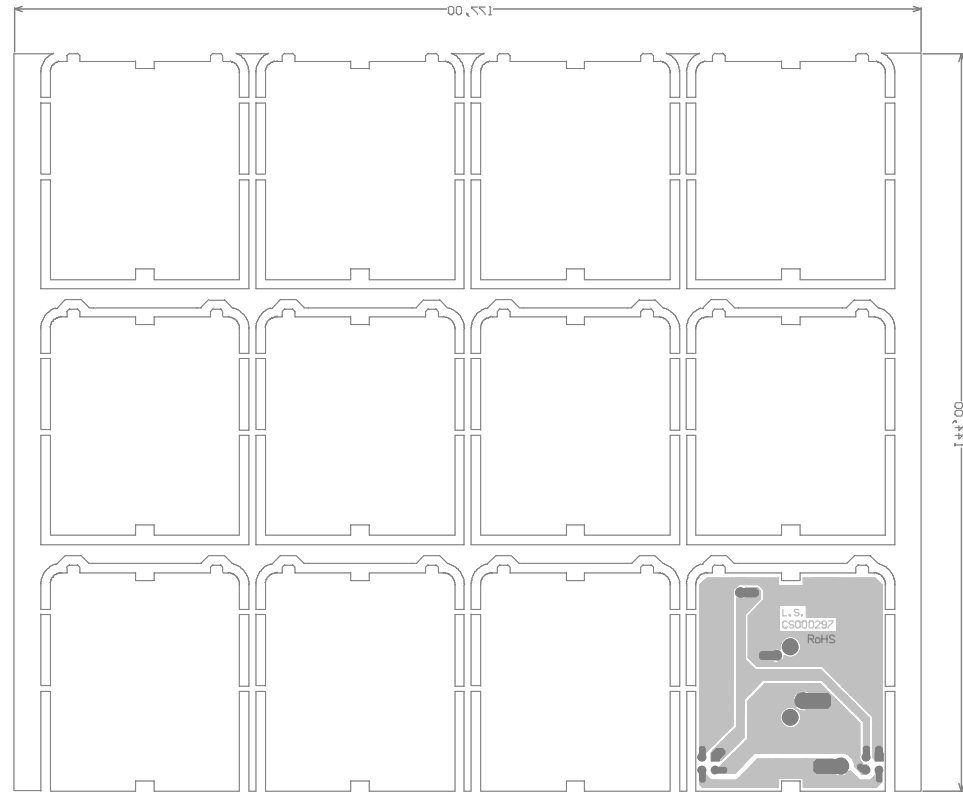
DGMCN  
TRL17  
BOTTO  
M  
LAYER  
BOTTO  
M  
SOLDER



DGMCN  
TRL17  
TOP  
M  
LAYER  
TOP  
OVERL  
AY  
TOP  
SOLDER

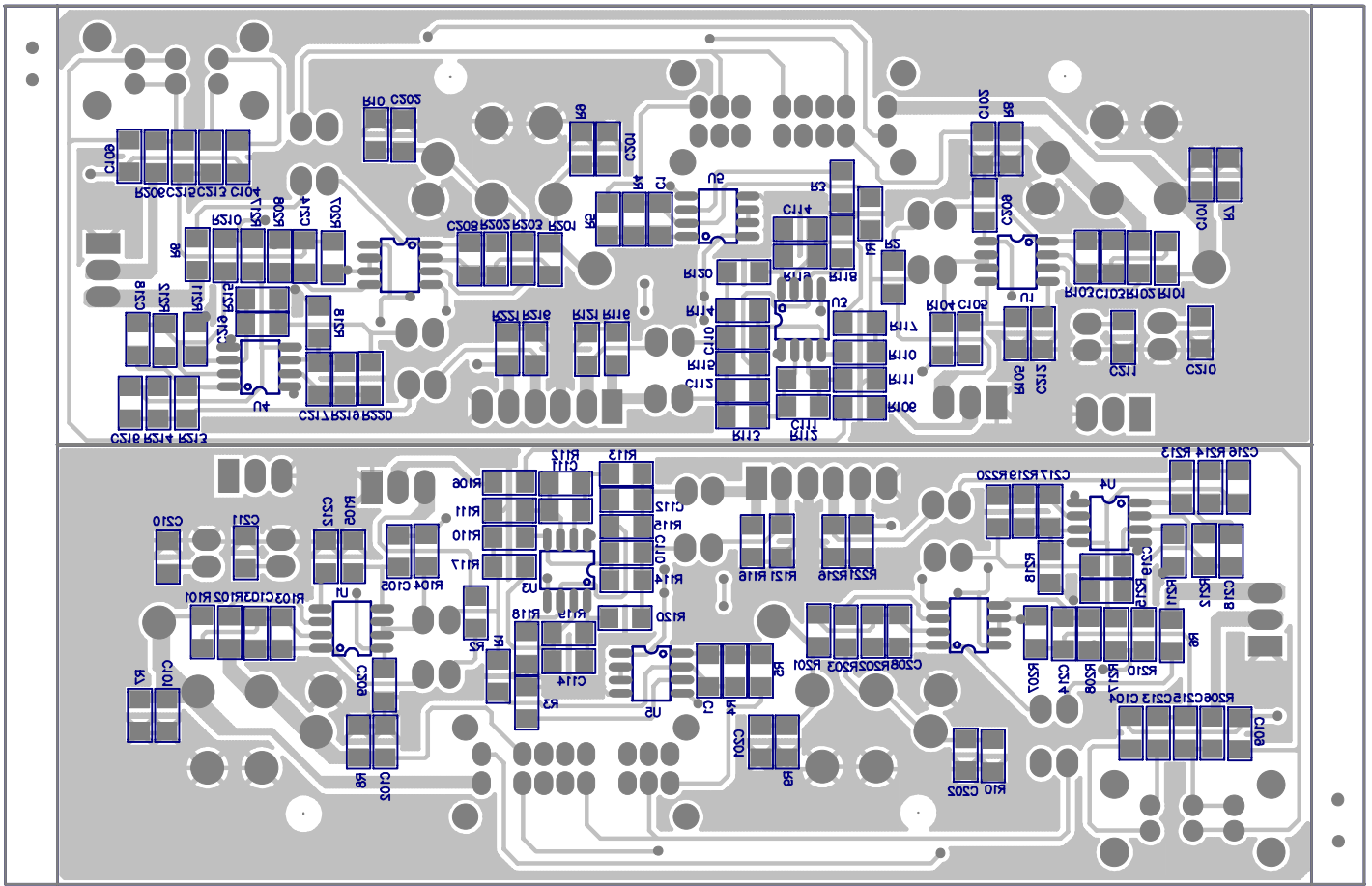


DGMFIL14 TOP LAYER TOP OVERLAY TOP SOLDER

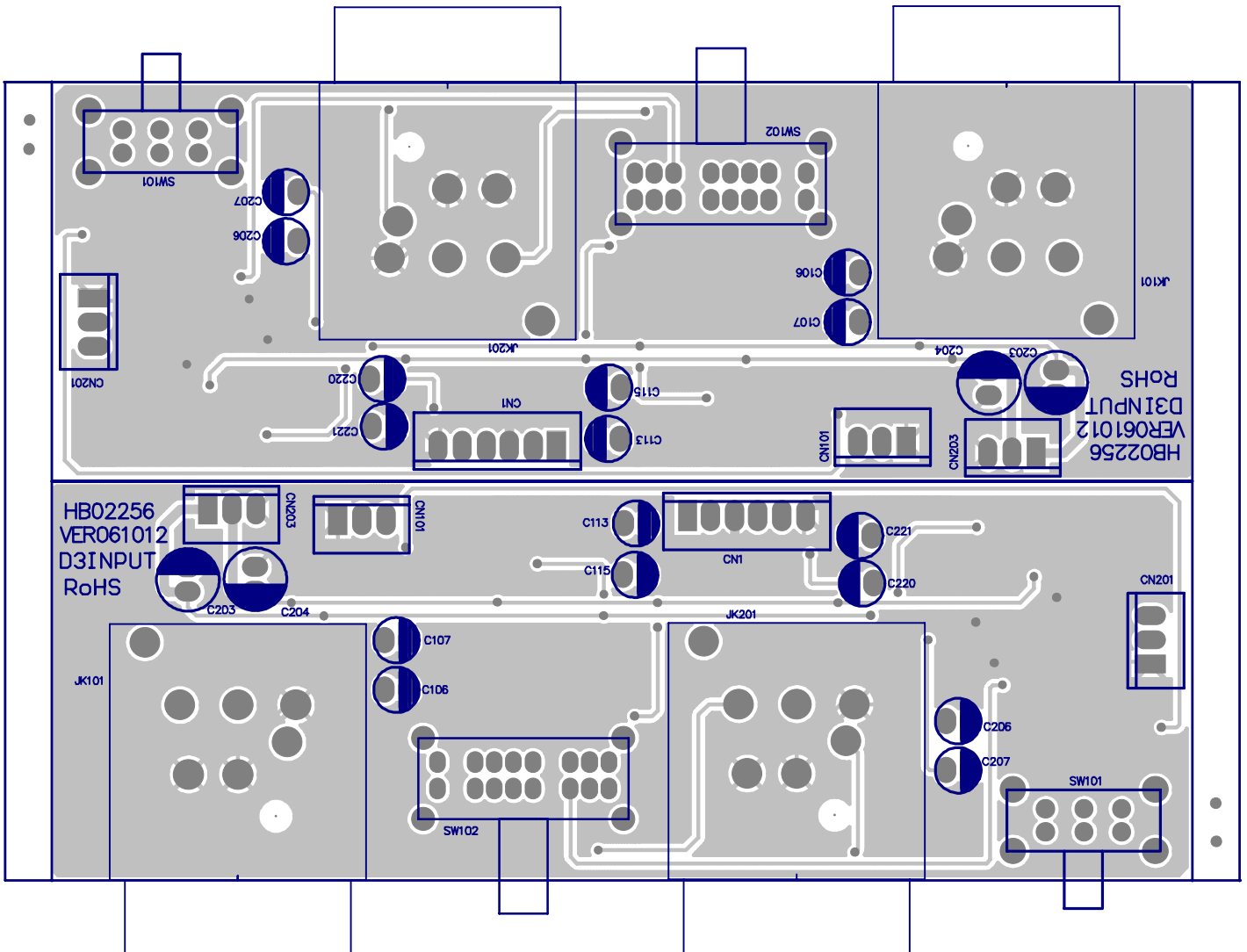


DGMFIL14BOTTOM LAYER BOTTOM SOLDER

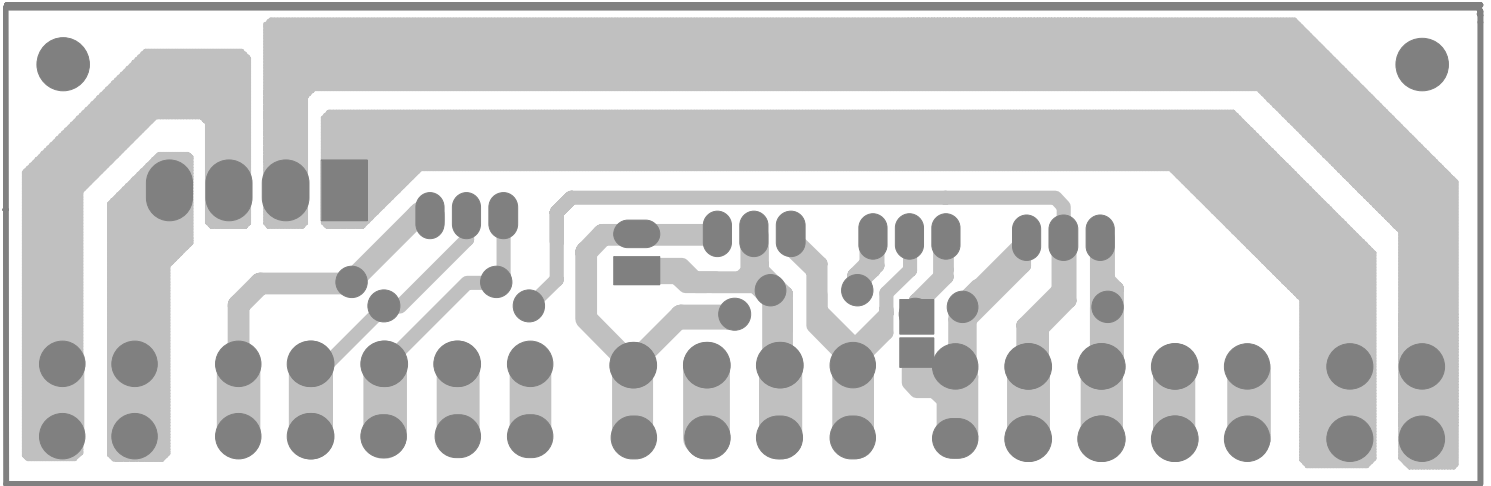




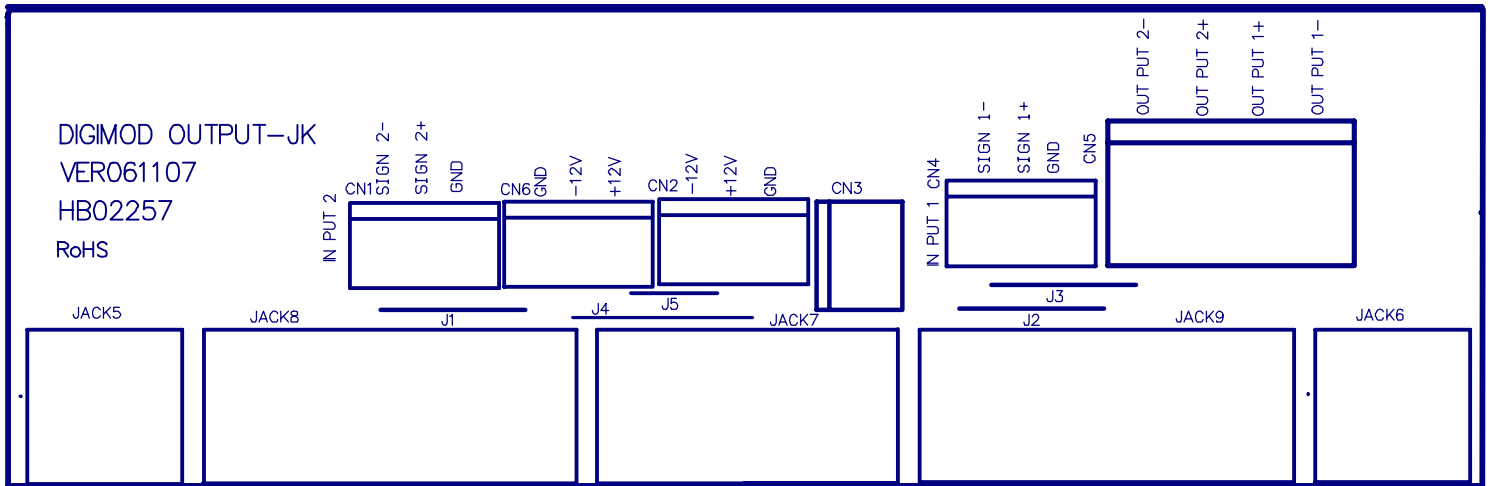
PCB:D-3-INPUT BOTTOM LAYER BOTTOM OVERLAY BOTTOM SOLDER



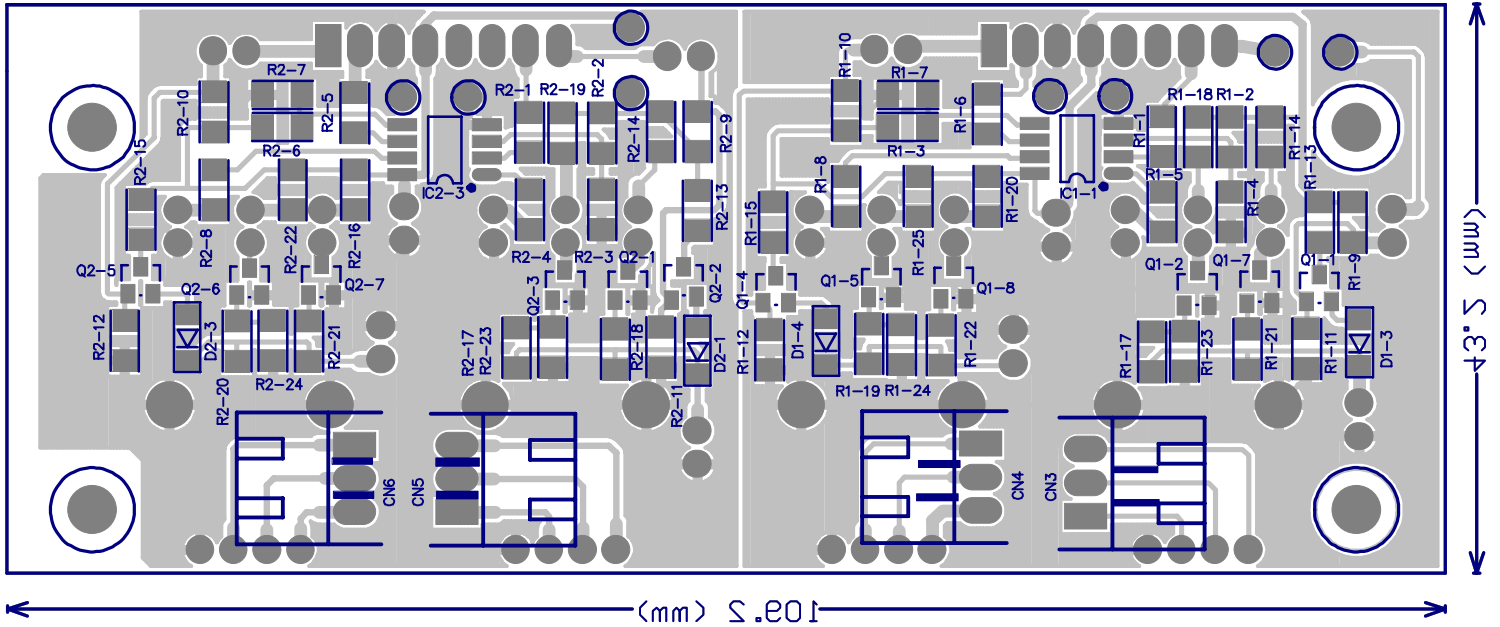
PCB:D-3-INPUT TOP LAYER TOP OVERLAY TOP SOLDER



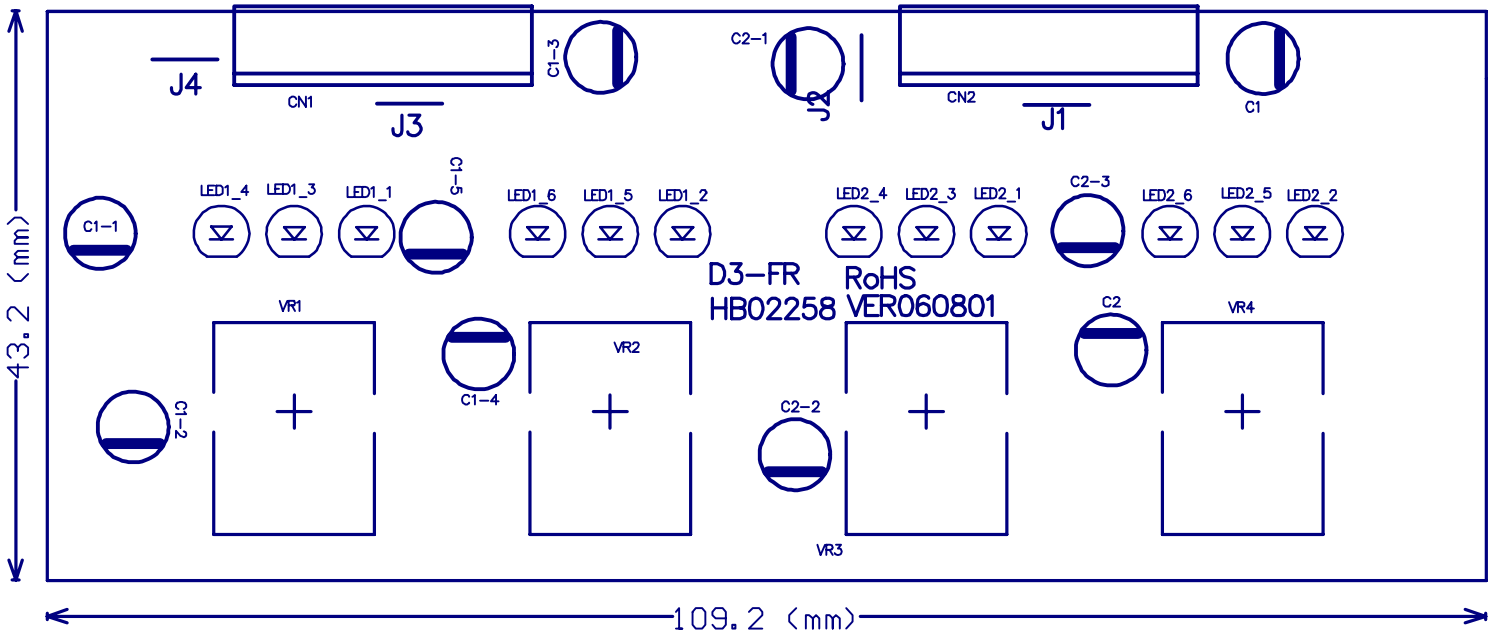
PCB:DIGIMOD OUTPUT-JK BOTTOM LAYER BOTTOM SOLDER



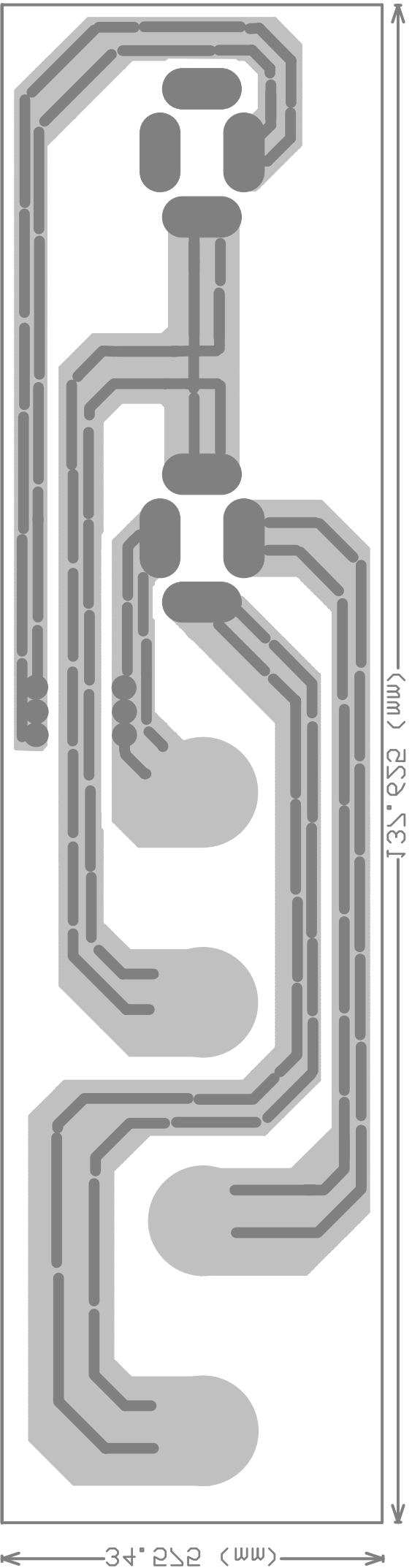
PCB:DIGIMOD OUTPUT-JK TOP OVERLAY



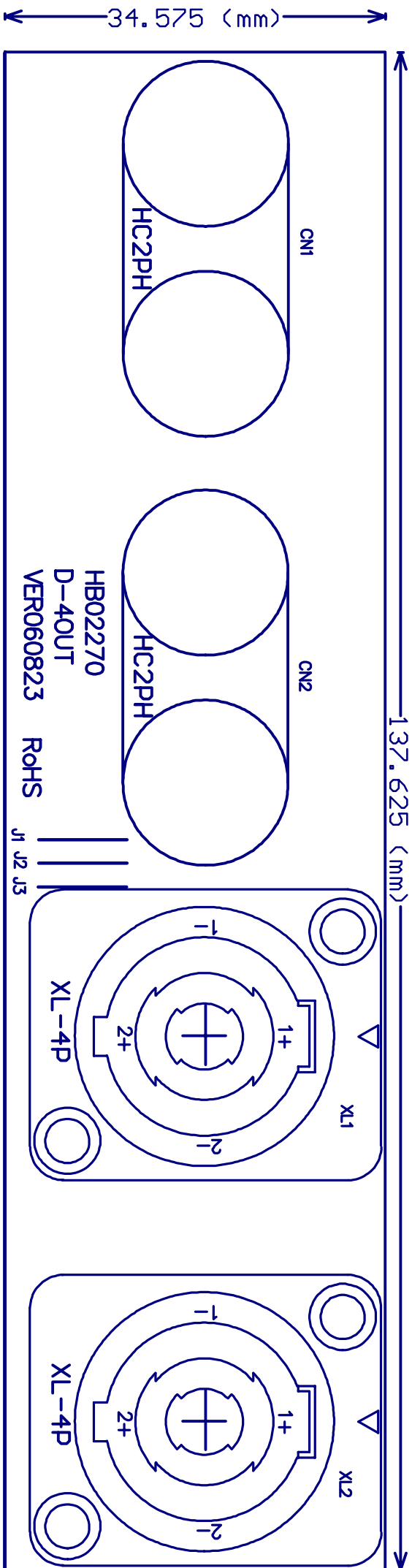
PCB:D-3-FR BOTTOM LAYER BOTTOM OVERLAY BOTTOM SOLDER



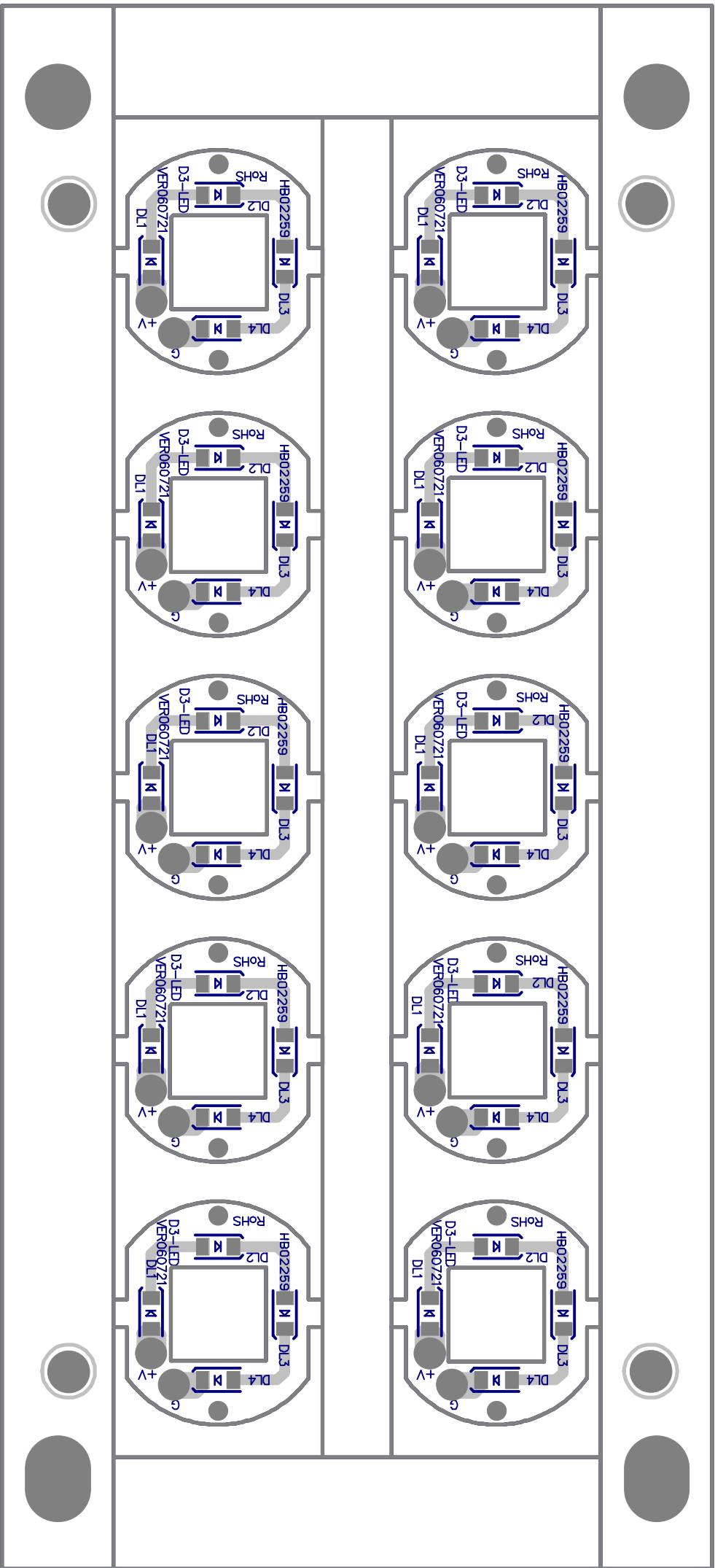
PCB:D-3-FR Top Layer



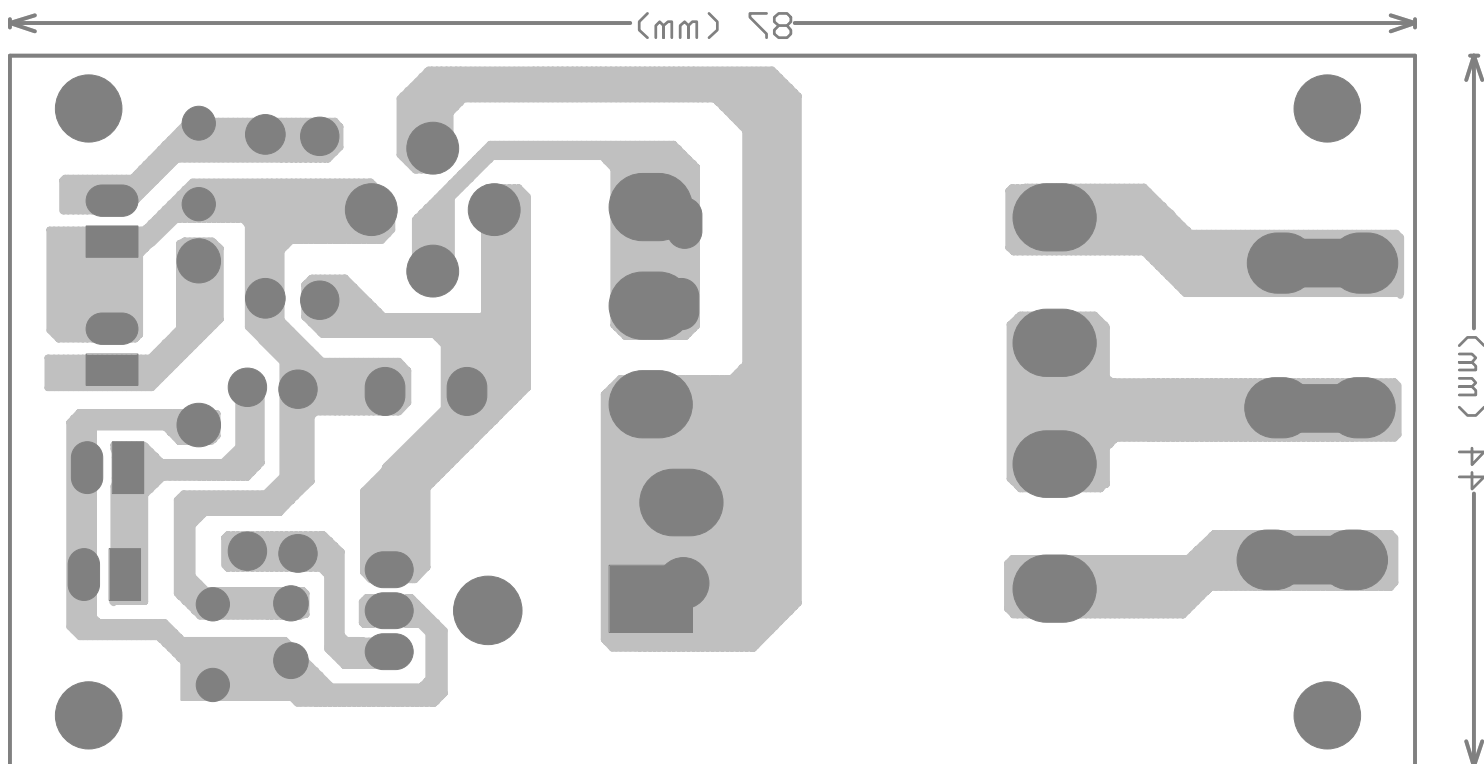
PCB:D-40UT BOTTOM LAYER BOTTOM SOLDER



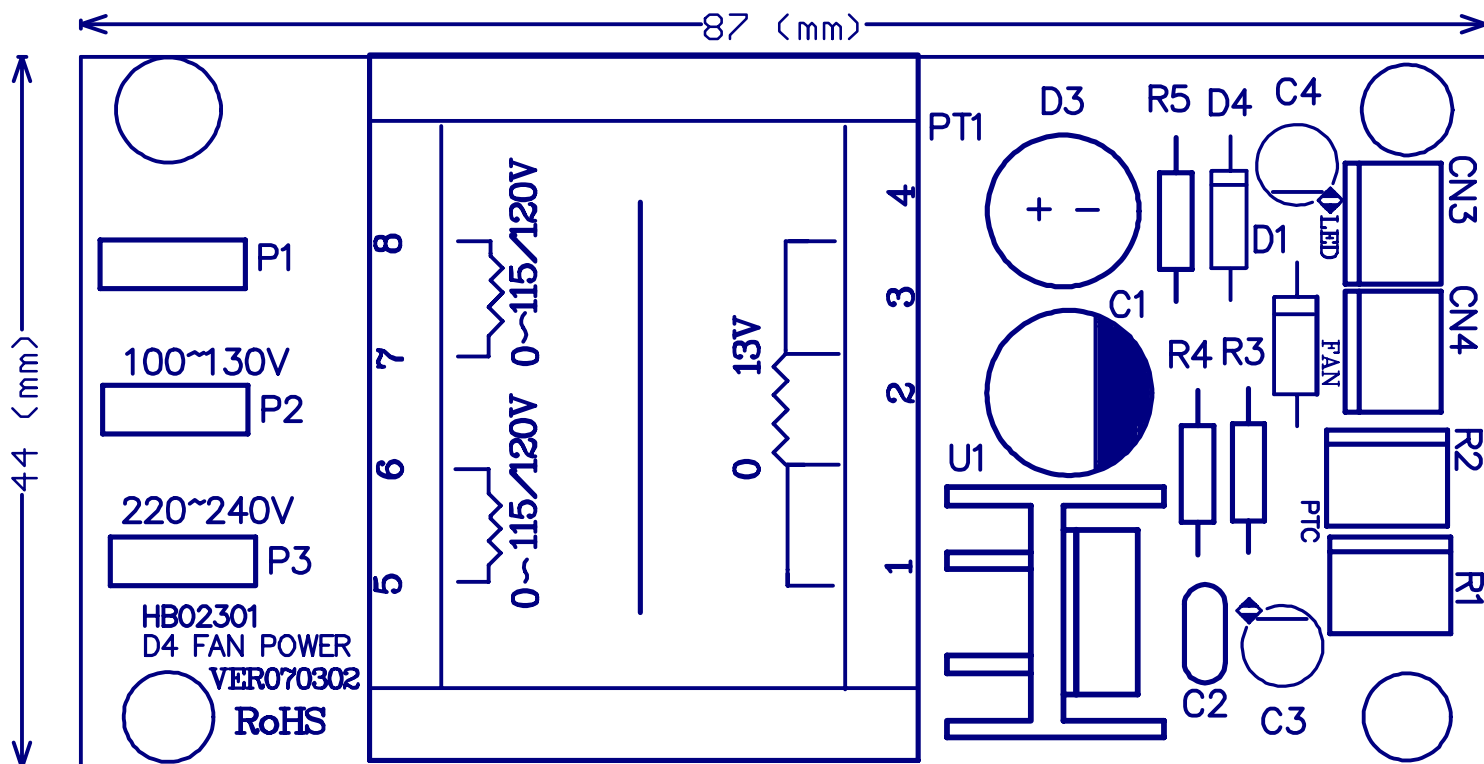
PCB:D-40UT TOP OVERLAY



PCB:D-3-LED TOP LAYER TOP OVERLAY TOP SOLDER



PCB:D4 FAN POEWR BOTTOM LAYER BOTTOM SOLDER



PCB:D4 FAN POEWR TOP OVERLAY

## 7. TEST PROCEDURE

### D1/D2

#### The Finished Products Test

##### 1. Equipments

1. APWIN 1.2
2. Multimeter
3. Frequency converter
4. 4 1000W load resistance\*2PCS
5. 8 1000W load resistance\*2PCS
6. Oscilloscope
7. AC protector

##### 2. TEST PROCEDURE

1. Initialize:
  - 1) The Power switch is in "OFF" status.
  - 2) Connect the Power cord to the AC protecting equipment.
  - 3) The Output of the frequency converter is 230V/50Hz; switch all the push switches to "OFF" position.
  - 4) The Output should be attenuated 10 times by the probe and connect to the oscilloscope.
2. Turn on the Power switch, the blue LED blinks frequently, The SIG, CLIP, PROT LEDs will turn off one second after turning on the machine.
3. Input 1 KHz/4dBu±1dBu RMS signal, adjust the VR and make the Output at 2W, the THD 0.5%.
4. Input 1 KHz/4dBu±1dBu RMS signal, adjust the VR and make the Output at 5V±2V, the SIG LED lights up.
5. Single Channel Output Test: Set the mode selector switch to the STEREO L position, with 4 loads at the Output, input 1KHZ/4dBuEIAJ signal to CH1, CH2, CH3, CH4, and rotate the corresponding VRs to the maximum, make sure the output of the oscilloscope(vpp) 127V±5V, it occurs slight clipping. Adjust the frequency to 400HZ /10dBu±1dBu, the CLIP LED starts to blink.

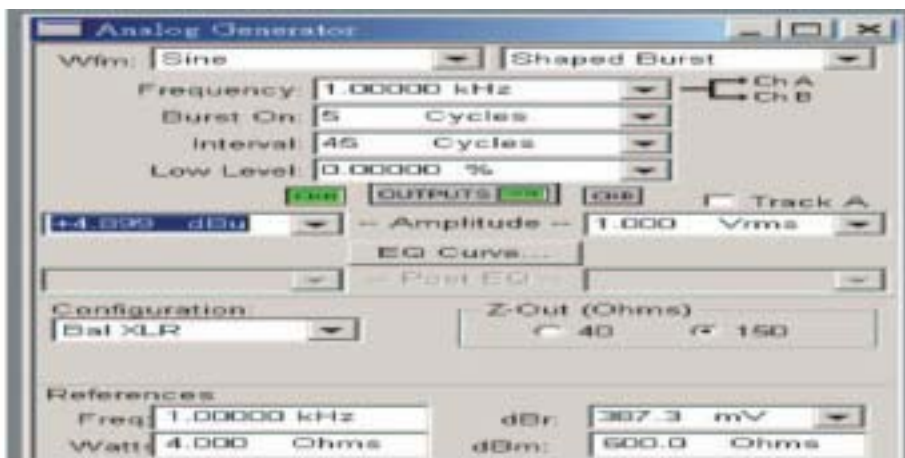


Figure (1) The Setting of EIAJ Signal

6. Short Circuit Protection Test: Input 1 KHz/4dBu±1dBu EIAJ signal, adjust the VR and make the Output 60V, at the short circuit protection, the protection PROT will light up or flash, the machine will not to be damaged.
7. Oscilloscope Test: set the mode selector switch to the STEREO position, input 1KHz 10dBu±0.5dBu RMS signal, turn the 30Hz FILTER to the "OFF" and "ON" position, the frequency response of the 30Hz -3dBu. See the attached Figure(2)
8. Frequency response Test: Input 1KHz 10dBu±0.5dBu RMS signal, adjust the VR and make the Output at 2W, when the frequency is 20HZ-20KHz, the frequency response -3dBu.
9. Signal channel test must repeat the procedure 3 to 8.
10. Parallel Connection: Follow up the third step, input 1 KHz 0dBu signal from CH1 or CH3, CH2 and CH4 disconnect the input signal, rotate the VRs of the CH2 and CH4 to maximum, CH2 and CH4 have no Output signals. Set the mode selector switch to the PARALLEL position, rotate the VRs of CH2 and CH4, the SIG LED on the panel lights up, and also can see the output waveform of CH2/CH4. (Note: CH1 and CH2 should be paralleled connect only, the same as CH3 and CH4)
11. Bridge Output Test: Set the mode selector switch to the STEREO position, the positive pole of the load should be connected to the positive pole of CH1's output, and the negative pole of the load should be connected to the positive pole of CH2's output. Input 1KHz 4.5dBu±1dBu EIAJ signal from CH1, turn the VR of CH1 to maximum, the VR of CH2 to minimum, with 8 loads at the output, make sure the output of the oscilloscope(vpp) 251V±5V, it has slight clipping; CH3 and CH4 bridge connected, and CH1 and CH2 is the same (Note: CH1 and CH2 should be bridged connection only, the same as CH3 and CH4).
12. Cut out the input signals of all the channels, at that time the standby consumption power: D1<25W; D2<50W.
13. After testing, it needs burning for 45 minutes, after no exceptional phenomenon occur, then package.



## D3/D4

### The Finished Products Test

#### 1. Equipments

1. APWIN 1.2
2. Multimeter
3. Frequency converter
4. 4 1000W load resistance\*2PCS
5. 8 1000W load resistance\*2PCS
6. Oscilloscope
7. AC protector

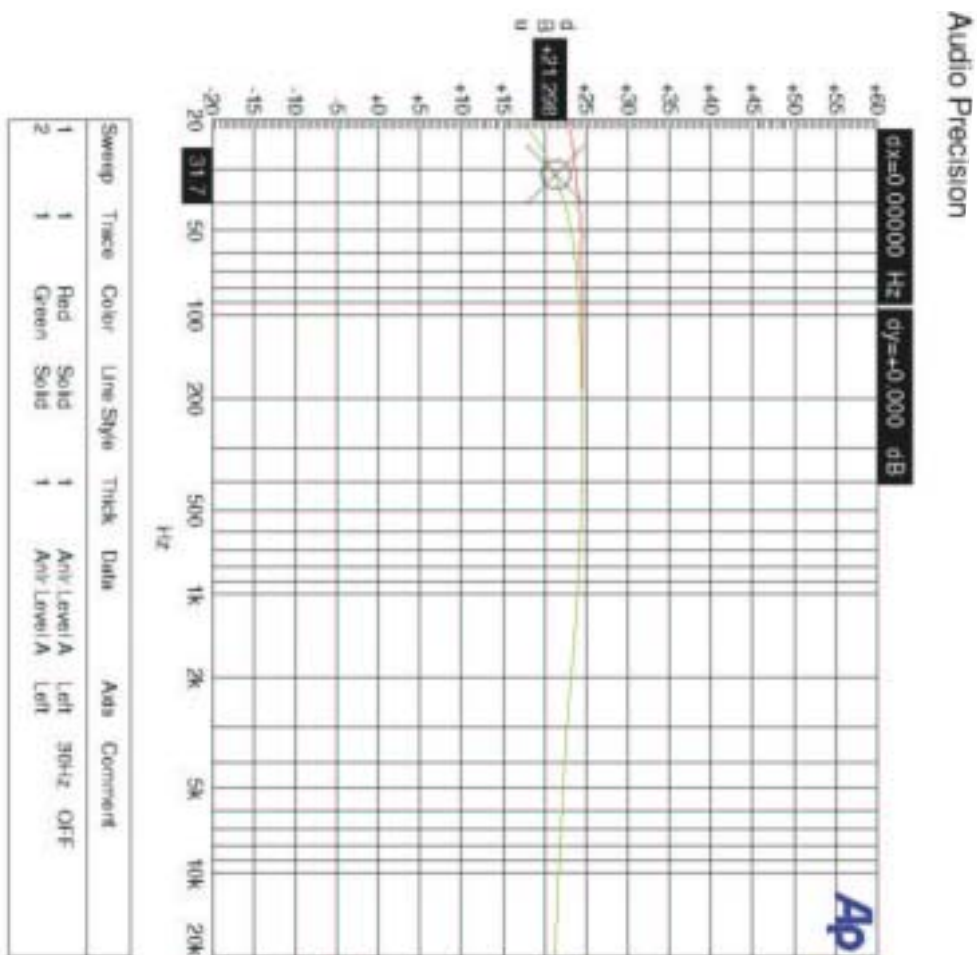
#### 2. Test Procedure

1. Initialize:
  - 1) The Power switch is in "OFF" status.
  - 2) Connect the Power cord to the AC protecting equipment.
  - 3) The Output of the frequency converter is 230V/50Hz; switch all the push switches to "OFF" position.
  - 4) The Output should be attenuated 10 times by the probe and connect to the oscilloscope.
2. Turn on the Power switch, the blue LED blinks frequently, The SIG, CLIP, PROT LEDs will turn off one second after turning on the machine.
3. Input 1 KHz/4dBu±1dBu RMS signal, adjust the VR and make the Output at 2W, the THD 0.5%.
4. Input 1 KHz/4dBu±1dBu RMS signal, adjust the VR and make the Output at 5V±2V, the SIG LED lights up.
5. Single Channel Output Test: Set the mode selector switch to the STEREO position, with 4 loads at the output, input 1KHZ/5dBuEIAJ signal to CH1, CH2, CH3, CH4, and rotate the corresponding VRs to maximum, make sure the output of the oscilloscope(vpp) 155V±5V, it occurs slight clipping. Adjust the frequency to 400HZ /10dBu±1dBu; the CLIP LED starts to blink.

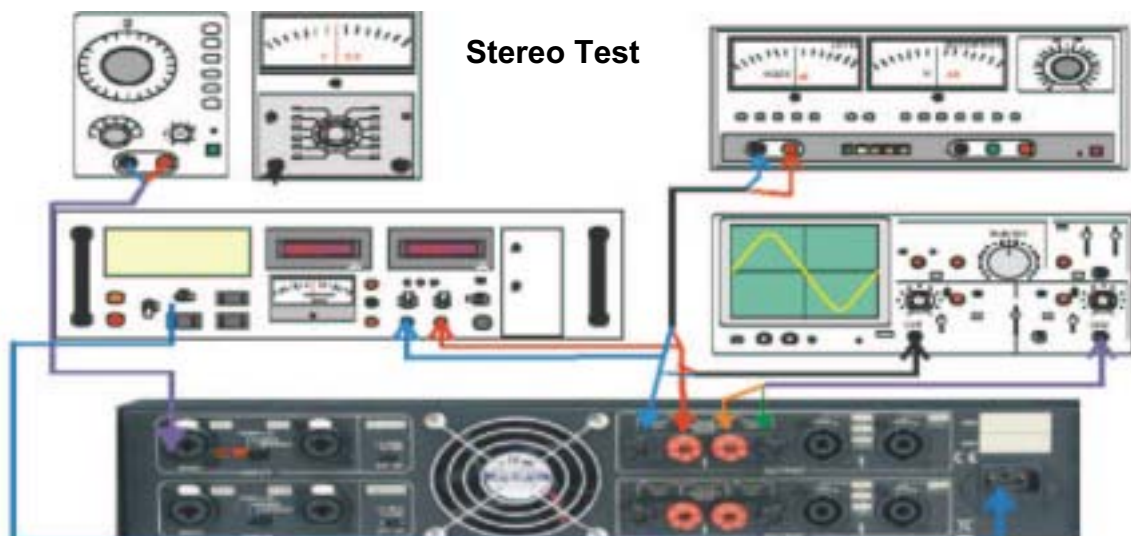


Figure (1) The Setting of the EIAJ signal

6. Short Circuit Protection Test: Because the short circuit of D3 and D4 will damage the module, so not take the short circuit test at the moment.
7. Oscilloscope Test: Set the mode selector switch to the STEREO position, input 1KHz 10dBu±0.5dBu RMS signal, turn the 30Hz FILTER to the "OFF" and "ON" position, the frequency response of the 30Hz -3dBu. See the attached Figure (2)
8. Frequency response Test: Input 1KHz 10dBu±0.5dBu RMS signal, adjust the VR and make the Output at 2W, when the frequency range is 20Hz-20KHz, the frequency response -3dBu.
9. Single Channel Test should repeat the procedure 3 to 8.
10. Parallel Connection: Follow up the third step, input 1 KHz 0dBu signal from CH1 or CH3, CH2 and CH4 disconnect the input signal, rotate the VRs of the CH2 and CH4 to maximum, CH2 and CH4 have no output signals. Set the mode selector switch to the PARALLEL position, rotate the VRs of CH2 and CH4, the SIG LED on the panel lights up, and also can see the output waveform of CH2/CH4. (Note: CH1 and CH2 should be paralleled connect only, the same as CH3 and CH4)
11. Bridge Output Test: Set the mode selector switch to the STEREO position, the positive pole of the load should be connected to the positive pole of CH1's output, and the negative pole of the load should be connected to the positive pole of CH2's output. Input 1KHz 6dBu±1dBu EIAJ signal from CH1, turn the VR of CH1 to maximum, the VR of CH2 to minimum, with 8 loads at the output, make sure the output of the oscilloscope(vpp) 303V±5V, it has slight clipping; CH3 and CH4 bridge connected, and CH1 and CH2 is the same (Note: only CH1 and CH2 should be bridged connection only, the same as CH3 CH4).
12. Cut out the input signals of all the channels, at that time the standby consumption power: D3<30W; D4<60W.
13. After testing, it needs burning for 45 minutes, after no exceptional phenomenon occur, then package.

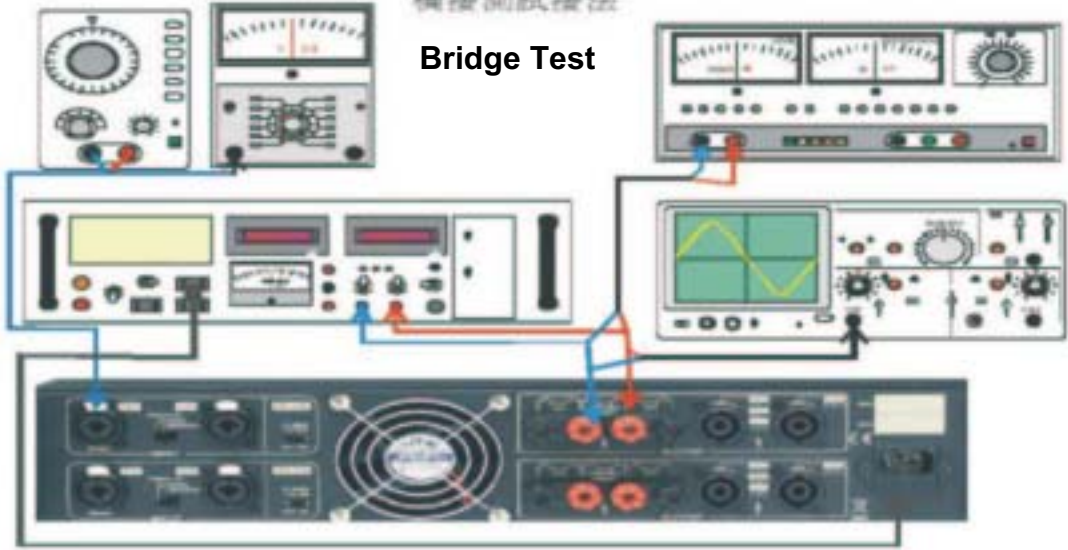


### Wiring Diagram of the Finished Products Test

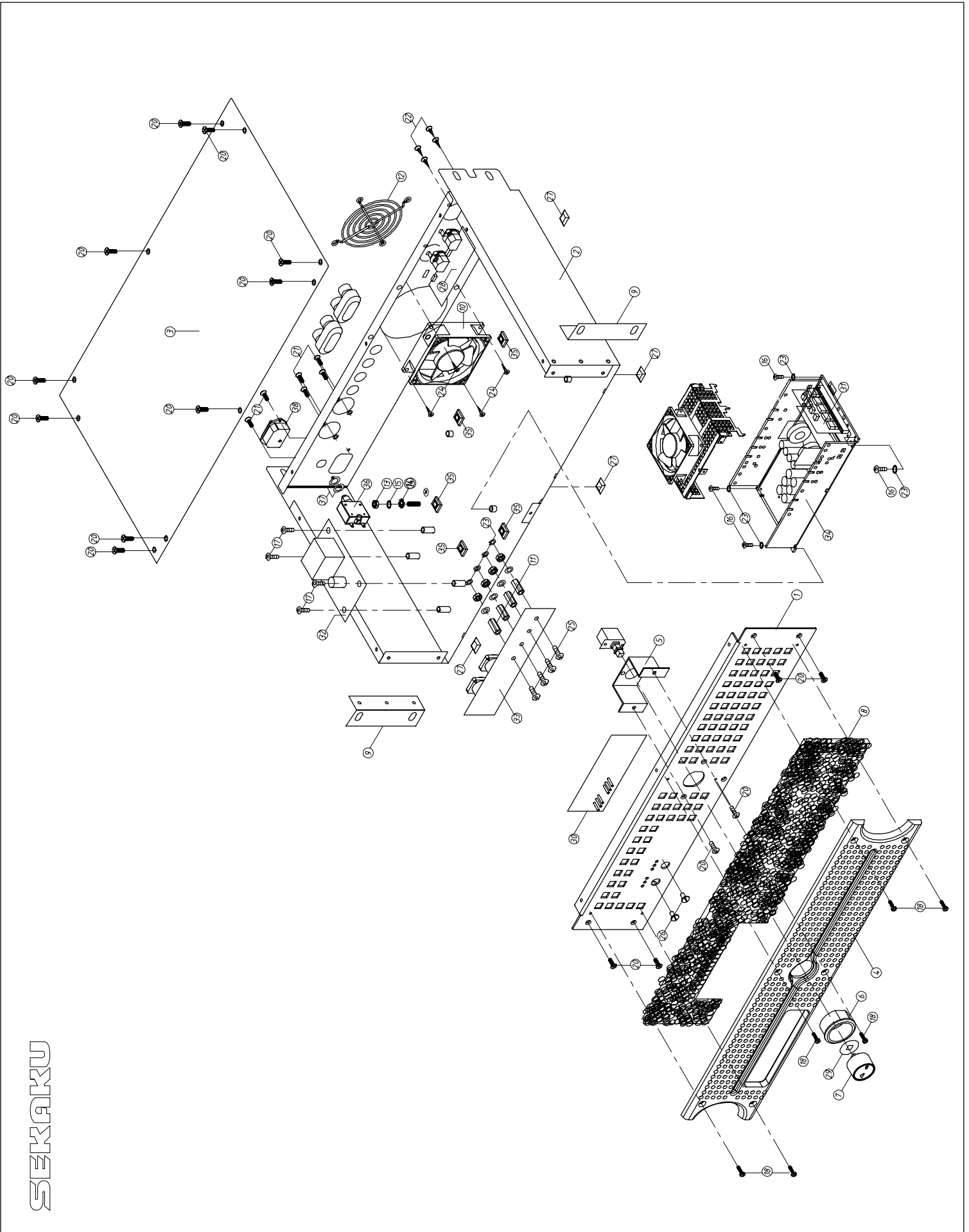


橋接測試接法

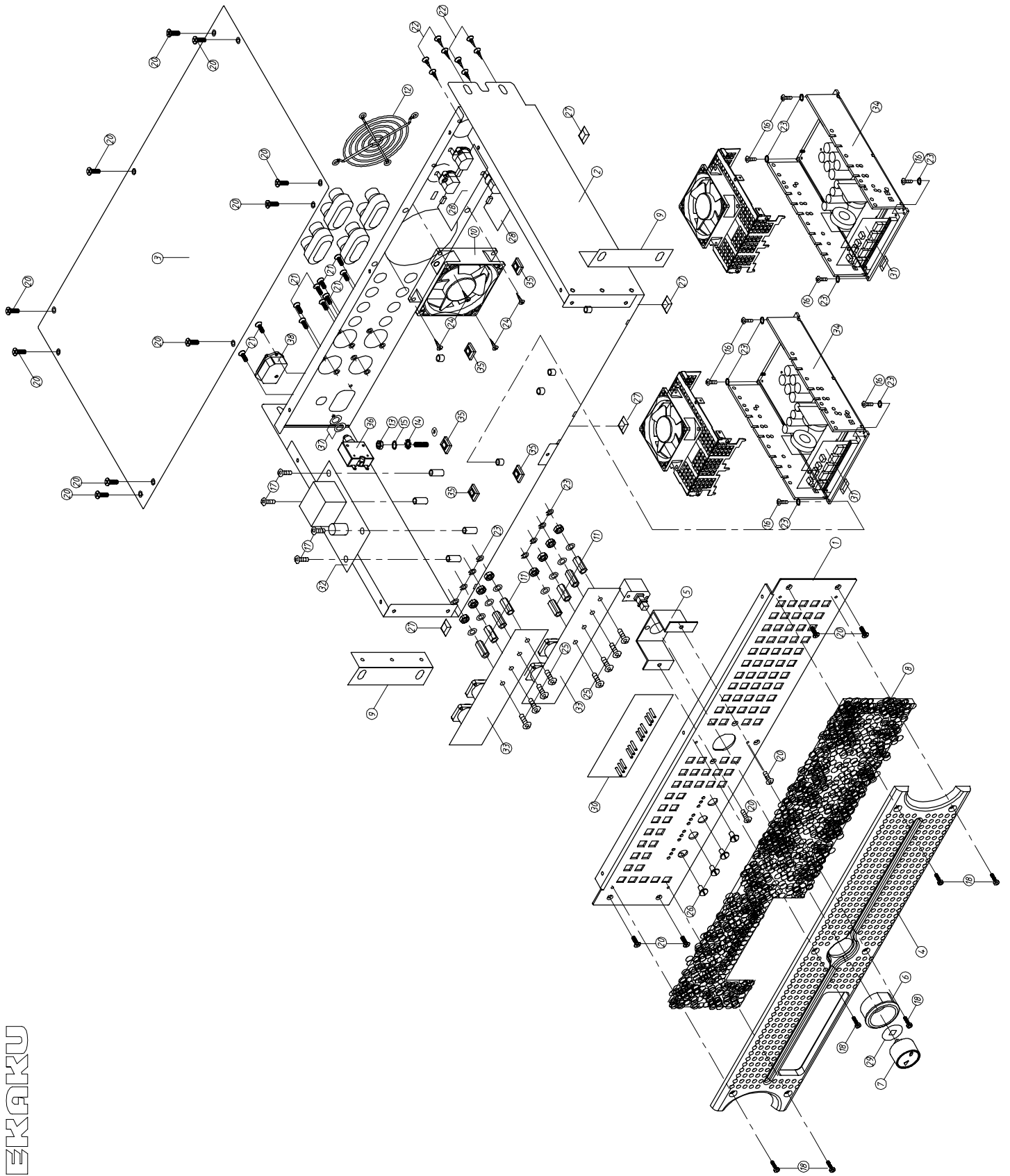
### Bridge Test



# 8. EXPLODED VIEW & MECHANICAL PARTS LIST



SEKAKU



# MECHANICAL PARTS LIST

## D1

No.	Part No.	Description	Specification	pcs
1	MA06384	ZC-panel	D1_V1.0	1
2	MB05105	ZC-chassis	D1_V1.0	1
3	MC00908	B-top cover	D1	1
4	NI04550	ZB-plastic panel	D1_V1.0	1
5	MI03890	D-fixed bracket	D1 1t*24.5*30*60_V1.0	1
6	NI04551	fixed cover	D1 f 25*12_V1.0	1
7	NI04553	pass light key	D1 18.5*17.7_V1.0	1
8	NI04554	leach net	D1 389*82*4t_V1.0	1
9	MH02231	nameplate symbol	D-1 ALTO_V1.0	1
10	TC00382	transformer	PT-LFB4185_115/230V(EI-41)	1
11	NE16991	ZC-voltage symbol	D4 220-240V~50/60Hz_V1.0	1
12	NE16990	ZC-voltage symbol	D2 220-240V~50/60Hz_V1.0	1
13	HB02256	PC B	D3INPUT_VER061012	1
14	HB02257	PC B	DAMP-JK_VER060720	1
15	HB02258	PC B	D3-FR_VER060801	1
16	HB02259	PC B	D-3-LED_VER060721	1
17	HB02270	PC B	D4OUTPUT_VER061005	2
18	HB02301	PC B	D4 FAN POWER_VER060915	1
19	HA04916	header wiring	4P 310mm UL1007 16AWG	1
20	HA04918	header wiring	6P-3P/3P 140mm UL2547 28AWG	1
21	HA04920	header wiring	8P-8P 400mm UL1007 28AWG rainbow	1
22	NF02695	user's manual	D series_1.0	1
23	HC00949	speakon	LD4015 female	2
24	HC00950	Combo MIC jack	LA1117 90°	2
25	HC00945	terminal block	2ESDCR-02P	2
26	HC00946	terminal block	2ESDCR-04P	1
27	HC00947	terminal block	2ESDCR-05P	2
28	NB05129	cardboard	D1 ALTO_V1.0	2
29	NB05130	inner case	D1 ALTO_V1.0	1
30	NB05133	carton	D1 ALTO_V1.0	1
31	NE17034	ZC-bar code	D1 bar code_V1.0	1
32	HA04967	terminal wiring	130mm UL1617 18AWG blue/blue	1
33	HA04968	terminal wiring	130mm/300mm UL1617 18AWG brown/brown	1

## D2

No.	Part No.	Description	Specification	pcs
1	MA06385	ZC-panel	D2_V1.0	1
2	MB05106	ZC-chassis	D2_V1.0	1
3	MC00910	B-top cover	D4	1
4	NI04550	ZB-plastic panel	D1_V1.0	1
5	MI03890	D-fixed bracket	D1 1t*24.5*30*60_V1.0	1
6	NI04551	fixed cover	D1 f 25*12_V1.0	1
7	NI04553	pass light key	D1 18.5*17.7_V1.0	1
8	NI04554	leach net	D1 389*82*4t_V1.0	1
9	MH02231	nameplate symbol	D-1 ALTO_V1.0	1
10	TC00382	transformer	PT-LFB4185_115/230V(EI-41)	1
11	NE16990	ZC-voltage symbol	D2 220-240V~50/60Hz_V1.0	1
12	NF02695	user's manual	D series_1.0	1
13	HB02256	PCB	D3INPUT_VER061012	2
14	HB02257	PCB	DAMP-JK_VER060720	2
15	HB02270	PCB	D4OUTPUT_VER061005	2
16	HB02258	PCB	D3-FR_VER060801	1
17	HB02301	PCB	D4 FAN POWER_VER060915	1
18	HB02259	PCB	D-3-LED_VER060721	1
19	HC00949	speakon	LD4015 female	4
20	HC00950	Combo MIC jack	LA1117 90°	4
21	HA04916	header wiring	4P 310mm UL1007 16AWG	1
22	HA04917	header wiring	4P 160mm UL1007 16AWG	1
23	HA04918	header wiring	6P-3P/3P 140mm UL2547 28AWG	1
24	HA04919	header wiring	6P-3P/3P 210mm UL2547 28AWG	1
25	HA04920	header wiring	8P-8P 400mm UL1007 28AWG rainbow	1
26	HA04921	header wiring	8P-8P 600mm UL1007 28AWG rainbow	1
27	HC00947	terminal block	2ESDCR-05P	4
28	HC00945	terminal block	2ESDCR-02P	4
29	HC00946	terminal block	2ESDCR-04P	2
30	NE17038	ZC-bar code	D2 bar code_V1.0	1
31	NB05128	card board	D2 ALTO_V1.0	2
32	NB05131	inner case	D2 ALTO_V1.0	1
33	NB05132	carton	D2 ALTO_V1.0	1
34	HA04966	terminalwiring	230mm UL1617 18AWG blue/blue	1
35	HA04965	terminalwiring	230mm/280mm UL1617 18AWG brown/brown	1



### D3

No.	Part No.	Description	Specification	pcs
1	MA06386	ZC-panel	D3_V1.0	1
2	MB05105	ZC-chassis	D1_V1.0	1
3	MC00908	B-top cover	D1	1
4	NI04550	ZB-plastic panel	D1_V1.0	1
5	MI03890	D-fixed bracket	D1 1t*24.5*30*60_V1.0	1
6	NI04551	fixed cover	D1 f 25*12_V1.0	1
7	NI04553	pass light key	D1 18.5*17.7_V1.0	1
8	NI04554	leach net	D1 389*82*4t_V1.0	1
9	MH02231	nameplate symbol	D-1 ALTO_V1.0	1
10	TC00382	transformer	PT-LFB4185_115/230V(EI-41)	1
11	NE16991	ZC-voltage symbol	D4 220-240V~50/60Hz_V1.0	1
12	NE16990	ZC-voltage symbol	D2 220-240V~50/60Hz_V1.0	1
13	HB02256	PCB	D3INPUT_VER061012	1
14	HB02257	PCB	DAMP-JK_VER060720	1
15	HB02258	PCB	D3-FR_VER060801	1
16	HB02259	PCB	D-3-LED_VER060721	1
17	HB02270	PCB	D4OUTPUT_VER061005	2
18	HB02301	PCB	D4 FAN POWER_VER060915	1
19	HA04916	terminal wiring	4P 310mm UL1007 16AWG	1
20	HA04918	terminal wiring	6P-3P/3P 140mm UL2547 28AWG	1
21	HA04920	header wiring	8P-8P 400mm UL1007 28AWG rainbow	1
22	NF02695	user's manual	D series_1.0	1
23	HC00949	speakon	LD4015 female	2
24	HC00950	Combo MIC jack	LA1117 90°	2
25	HC00945	terminal block	2ESDCR-02P	2
26	HC00946	terminal block	2ESDCR-04P	1
27	HC00947	terminal block	2ESDCR-05P	2
28	NB05129	card board	D1 ALTO_V1.0	2
29	NB05130	inner case	D1 ALTO_V1.0	1
30	NB05133	carton	D1 ALTO_V1.0	1
31	NE17037	ZC-bar code	D3bard code_V1.0	1
32	HA04967	terminal wiring	130mm UL1617 18AWG blue/blue	1
33	HA04968	terminal wiring	130mm/300mm UL1617 18AWG brown/brown	1

## D4

No.	Part No.	Description	Specification	pcs
1	MA06387	ZC-panel	D4_V1.0	1
2	MB05106	ZC-chassis	D2_V1.0	1
3	MC00910	B-top cover	D4	1
4	NI04550	ZB-plastic panel	D1_V1.0	1
5	MI03890	D-fixed bracket	D1 1t*24.5*30*60_V1.0	1
6	NI04551	fixed cover	D1 f 25*12_V1.0	1
7	NI04553	pass light key	D1 18.5*17.7_V1.0	1
8	NI04554	leach net	D1 389*82*4t_V1.0	1
9	MH02231	nameplate symbol	D-1 ALTO_V1.0	1
10	TC00382	transformer	PT-LFB4185_115/230V(EI-41)	1
11	NE16991	ZC-voltage symbol	D4 220-240V~50/60Hz_V1.0	1
12	NF02695	user's manual	D series_1.0	1
13	HB02256	PCB	D3INPUT_VER061012	2
14	HB02257	PCB	DAMP-JK_VER060720	2
15	HB02270	PCB	D4OUTPUT_VER061005	2
16	HB02258	PCB	D3-FR_VER060801	1
17	HB02301	PCB	D4 FAN POWER_VER060915	1
18	HB02259	PCB	D-3-LED_VER060721	1
19	HC00949	speakon	LD4015 female	4
20	HC00950	Combo MIC jack	LA1117 90°	4
21	HA04916	header wiring	4P 310mm UL1007 16AWG	1
22	HA04917	header wiring	4P 160mm UL1007 16AWG	1
23	HA04918	header wiring	6P-3P/3P 140mm UL2547 28AWG	1
24	HA04919	header wiring	6P-3P/3P 210mm UL2547 28AWG	1
25	HA04920	header wiring	8P-8P 400mm UL1007 28AWG rainbow	1
26	HA04921	header wiring	8P-8P 600mm UL1007 28AWG rainbow	1
27	HC00947	terminal block	2ESDCR-05P	4
28	HC00945	terminal block	2ESDCR-02P	4
29	HC00946	terminal block	2ESDCR-04P	2
30	NE17036	ZC-bar code	D4 bar code_V1.0	1
31	NB05128	card board	D2 ALTO_V1.0	2
32	NB05131	inner case	D2 ALTO_V1.0	1
33	NB05132	carton	D2 ALTO_V1.0	1
34	HA04966	terminal wiring	230mm UL1617 18AWG blue/blue	1
35	HA04965	terminal wiring	230mm/280mm UL1617 18AWG brown/brown	1

## D1&D3

No.	Part No.	Description	Specification	pcs
1	MA06386	ZC-panel	D3_V1.0	1
2	MB05105	ZC-chassis	D1_V1.0	1
3	MC00939	ZC-top cover	D3_V1.0	1
4	NI04550	ZB-plastic cover	D1_V1.0	1
5	MI03890	D-fixed bracket	D1 1t*24.5*30*60_V1.0	1
6	NI04551	fixed cover	D1 f 25*12_V1.0	1
7	NI04553	pass light key	D1 f 18.5*17.7_V1.0	1
8	NI04554	leach net	D1 389*82*4t_V1.0	1
9	MI02856	ZB-fixed bracket	PA-240P 2.0t*24*26*88 Lmould_V1.0	2
10	HE00065	fan	DC12V/0.19A 80*80*25 380mm JST2P	1
11	MG00534	copper post	M5*16_V1.0	4
12	MD00444	fan protecting cover	80*80mm(K-G08A05-4HA)	1
13	ME00016	multicolored nut	4mm	1
14	MF00048	outtooth washer	4* 8*0.5t	1
15	MF00038	spring washer	4* 7*1t	5
16	MG00378	screw	M4*8	4
17	MG00041	screw	M3*6	6
18	MG00028	screw	M3*10	4
19	MG00262	screw	M4*8	6
20	MG00025	screw	M3*6	6
21	MG00042	screw	M3*10	6
22	MG00045	screw	M3*7	4
23	MF00039	spring washer	5* 8*1t	4
24	MG00268	nickel screw	M5*12	4
25	MG00535	nickel screw	M5*6_V1.0	4
26	NI00360	plastic knob	15*15mm	2
27	NI01867	self-adhere foot cushion	20.5*14*7.6mm(SF-006)	4

## D2&D4

No.	Part No.	Description	Specification	pcs
1	MA06385	ZC-panel	D2_V1.0	1
2	MB05106	ZC-chassis	D2_V1.0	1
3	MC00940	ZC-top cover	D4_V1.0	1
4	NI04550	ZB-plastic panel	D1_V1.0	1
5	MI03890	D-fixed bracket	D1 1t*24.5*30*60_V1.0	1
6	NI04551	fixed cover	D1 f 25*12_V1.0	1
7	NI04553	pass light key	D1 f 18.5*17.7_V1.0	1
8	NI04554	leach net	D1 389*82*4t_V1.0	1
9	MI02856	ZB-fixed bracket	PA-240P 2.0t*24*26*88 Lmould	2
10	HE00065	fan	DC12V/0.19A 80*80*25 380mm	1
11	MG00534	copper post	M5*16_V1.0	8
12	MD00444	fan protecting cover	80*80mm(K-G08A05-4HA)	1
13	ME00016	multicolored nut	4mm	1
14	MF00048	outtooth washer	4* 8*0.5t	1
15	MF00038	spring washer	4* 7*1t	9
16	MG00378	screw	M4*8	8
17	MG00041	screw	M3*6	6
18	MG00028	screw	M3*10	4
19	MG00262	screw	M4*8	6
20	MG00025	screw	M3*6	18
21	MG00042	screw	M3*10	10
22	MG00045	screw	M3*7	8
23	MF00039	spring washer	5* 8*1t	8
24	MG00268	nickel screw	M5*12	4
25	MG00535	nickel screw	M5*6_V1.0	8
26	NI00360	plastic knob	15*15mm	4
27	NI01867	self-adhere foot cushion	20.5*14*7.6mm(SF-006)	4

## 9. BOM

Stage	Part No.	Description	Specification	
PI01720		STEREO AMPLIFIER	D1 ALTO 230V	
0001	MA06384	panel-RS	D1 ALTO V1.0	
0001	MA06344	panel-RS	D1	
0001	AE00284	paint	5063	
0002	AE00252	printing ink	senior silver ink	
0003	MA06343	panel-RS	D1 1.5t*430*86.8*15 V1.0	
0001	ME00106	iron pillar	M3*24*0.5PH V1.1	
0002	MJ00088	single light board	1.5*2135*1220 30.67kg	
0002	MB05105	chassis-RS	D1 V1.0	
0001	MB05069	chassis-RS	D1	
0001	AE00055	solvent	solvent	
0002	AE00060	paint-RS	4534	
0003	MB05068	chassis-RS	D1 1.2t*87.3*275.5*430 V1.0	
0001	ME00001	screw pillar	M4*10*0.7PH	
0002	ME00051	iron pillar	M3*12	
0003	ME00033	iron pillar	hexagon6.35*M4*5.2	
0004	MJ00059	single light board	1.2*2135*1220 24.54kg	
0003	MC00939	top cover-RS	D3 V1.0	
0001	MC00908	top cover-RS	D1	
0001	AE00055	solvent	solvent	
0002	AE00060	paint-RS	4534	
0003	MC00907	top cover-RS	D1 1.2*244.5*430 V1.0	
0001	MJ00059	single light board	1.2*2135*1220 24.54kg	
0004	MI03890	fixed bracket-RS	D1 1t*23*30*60 V1.1	
0001	MJ00061	iron board	1*2135*1220 20.45kg	
0005	NI04551	fixed sleeve-RS	D1 u25*12 V1.0	
0006	NI04553	button-RS	D1 u18.5*17.7 V1.0	
0007	NI04554	net-RS	D1 395*82*4t V1.0	
0008	MH02231	lable-RS	D-1 ALTO V1.0	
0009	MI02856	fixed bracket	PA-240P 2.0t*24*26*88 Ltype V1.0	
0001	MI02855	fixed bracket	PA-240P 2.0t*24*26*88 Ltype V1.1	
0001	MJ01154	single light board	2.0t*1850*950mm 27.6kg	
0002	AE00343	solvent	NO.330	
0003	AE00056	paint-RS	2745	
0010	HE00005	fan-RS	DC12V/3000RPM80*80*25mm 380mm 2.5 2P	
0011	MG00534	copper pillar	M5*16 V1.0	
0012	MD00444	protective cover	80*80mm(K-G08A05-4HA)	
0013	HC00295	quick terminal	JS205-110	

Stage	Part No.	Description	Specification	
0014	HC00005	AC socket-RS	AC-008	
0015	ME00016	color nut	4m/m	
0016	MF00048	washer	u4*u8*0.5t	
0017	MF00038	washer	u4*u7*1t	
0018	MG00161	screw	M3*6	
0019	MG00378	screw	M4*8	
0020	MG00041	screw	M3*6	
0021	MG00028	screw	M3*10	
0022	MG00262	screw	M4*8	
0023	MG00025	screw-RS	M3*6	
0024	MG00042	screw	M3*10	
0025	MG00327	screw	M3*10*0.5PH	
0026	MF00039	washer	u5*u8*1t	
0027	MG00268	screw	M5*12	
0028	MG00535	screw	M5*6 V1.0	
0029	NI00360	knob	u15*15mm	
0030	NI01867	cushion	20.5*14*7.6mm(SF-006)	
0031	NE11347	label	ALTO PI	
0001	NH00334	cone paper	0.040*1m	
0032	NE17466	lable-RS	D1 220-240V~50/60Hz V1.0	
0001	NI00023	membrane	0.085*1M	
0002	NH00018	bond paper	0.09*1M	
0033	NF00061	assurance card	ALTO	
0034	NA00279	clip-chain bag	0.04t*100*150mm V1.0	
0035	NA00135	PE bag	0.05t*610*500mm	
0036	NA00122	PE bag	0.04t*350*230mm	
0037	NA00137	clip-chain bag	5*7	
0038	HJ00006	dessicant	30g	
0039	NI00222	sleeve	u1.5*30mm	
0001	NI00221	sleeve	1.5u*1000mm	
0040	NI00268	sleeve	u6*20mm	
0001	NI00266	sleeve	u6*1000mm	
0041	HA04066	wire-RS	3P-3P 480mm UL2547 28AWG	
0042	HA02856	wire-RS	3P-3P 160mm UL1007 24AWG	
0043	HA02469	wire-RS	3P-3P 480mm UL2547 28AWG blue	
0044	HA02322	wire-RS	385mm UL1015 14AWG brown	
0045	HA01271	signle terminal wiring	60 (PC250,PC187)	
0046	HA02230	wire-RS	100mm UL1015 16AWG	
0047	HA02008	wire-RS	2P 220mm UL2468 26AWG	
0048	HA04918	wire-RS	6P-3P/3P 140mm UL2547 28AWG	
0049	HA04916	wire-RS	4P 260mm UL1007 16AWG	
0050	HA04920	wire-RS	8P-8P 400mm UL1007 28AWG	
0051	HA00861	power cord Europe 3P	LT-312+LT-501	
0052	HK07778	PC board	P-D3-IN	

Stage	Part No.	Description	Specification	
0001	HI00128	slide switch	3-stages 16P SLB-43-10	SW102
0002	HI00125	slide switch	SL20202-25Y-6mm	SW101
0003	HC00950	C	LA1117 90°	JK101,JK201
0004	HC00080	connector(male)	6P 2.5mm 180°	CN1
0005	HC00077	connector(male)	3P 2.5mm 180°	CN203,CN101,CN201
0006	CB00235	electrolytic capacitor	100uF/25V $\mu$ 6*11mm	C203,C204
0007	CB00260	electrolytic capacitor	47uF/35V $\mu$ 5*11mm 2.5mm	C113,C115,C220,C221
0008	CB00191	electrolytic capacitor	4.7uF/50V NP $\mu$ 5*11mm	C106,C107,C206,C207
0009	HK07820	PC board	P-D3INPUT-SMD	
0001	RD00417	SMD precise resistor 1/4W	27.0K $\pm$ 1% 1206	R1,R3,R4
0002	RD00142	SMD fixed resistor 1/4W	10K $\pm$ 5% 1206	R10,R110,R117,R2,R210,R217, R6,R7,R8,R9,R101,R102,R103, R201,R202,R203
0003	RD00320	SMD precise resistor 1/4W	12.0K $\pm$ 1% 1206	R111,R218
0004	RD00600	SMD precise resistor- RS 1/4W	68.0 $\pm$ 1% 1206	R113,R120,R213,R220
0005	RD00430	SMD precise resistor 1/4W	5.6 $\pm$ 1% 1206	R114,R115,R214,R215
0006	RD00252	SMD precise resistor 1/4W	22.0K $\pm$ 1% 1206	R116,R121,R216,R221
0007	RD00601	SMD precise resistor- RS 1/4W	8.20K $\pm$ 1% 1206	R118,R211
0008	RD00452	SMD precise resistor 1/4W	15.0K $\pm$ 1% 1206	R119,R212,R219,R207,R112, R104
0009	RD00245	SMD precise resistor 1/4W	1.00K $\pm$ 1% 1206	R5
0010	RD00636	SMD precise resistor- RS 1/4W	47.0K $\pm$ 1 1206	R105,R208
0011	RD00133	1/4W	100 $\pm$ 5% 1206	R106,R206
0012	CI00269	SMD ceramic capacitor-RS 1206	1.0uF/25V X7R $\pm$ 10%	C104,C105,C213,C214
0013	CI00095	SMD ceramic capacitor 1206	0.1uF/50V X7R	C109,C209,C210,C211,C212, C215
0014	SG00122	SMD integrated circuit-RS-ACT	NJM4580M-TE3(SOP8)/(JRC)	U1,U2,U3,U4,U5
0015	HB02256	PCB-RS	D3INPUT VER061012	
0016	CI00181	SMD ceramic capacitor 1206	27PF/50V NPO $\pm$ 5%	C1,C101,C102,C110,C111,C112 ,C114,C216,C217,C218,C219, C201, C202,C103,C208
0010	AC00179	tin without lead-RS	M705E Sn 3Ag-0.5Cu	
0053	HK07779	PC board	P-D3-FR	
0001	CB00263	electrolytic capacitor	10uF /25V $\mu$ 4*7mm	C1-2,C1-1,C1-4,C1-3
0002	CB00193	electrolytic capacitor	47uF/16V $\mu$ 6*7mm	C1-5
0003	HC00066	connector(male)	3P 2.5mm 90°	CN4,CN3
0004	HC00072	row-wire header	connector(male)	CN1
0005	SA00052	L.E.D	$\mu$ 3 round(green)long foot 26	LED1 4,LED1 6

Stage	Part No.	Description	Specification	
0006	SA00053	L.E.D	ϕ3 round(red)long foot 26mm	LED1 5,LED1 3,LED1 2, LED1 1
0007	RC00632	potentiometer-RS	A10K_ RV110-40E1-175A-A10K	VR2,VR1
0008	HA01919	jump	5mm	J3,J4
0001	HA02249	wire	ϕ0.6 tin-plating	
0009	NI02532	LED spacer support	LEDS-22 22mm	
0010	HK07821	PC board	P-D3FR-SMD	
0001	SE00011	SMD rectifier diode	RLS4148 0.5A (LL-34)	D1-4,D1-3
0002	RD00147	1/4W	100K_ ±5% 1206	R1-12,R1-11
0003	RD00142	SMD fixed resistor 1/4W	10K_ ±5% 1206	R1-19,R1-17,R1-8,R1-7,R1-6, R1-5,R1-4,R1-3,R1-2,R1-1
0004	RD00140	1/4W	4.7K_ ±5% 1206	R1-22,R1-21
0005	RD00138	1/4W	1.0K_ ±5% 1206	R1-15,R1-13
0006	RD00153	1/4W	820K_ ±5% 1206	R1-10,R1-9
0007	RD00247	SMD precise resistor 1/4W	2.20K_ ±1% 1206	R1-25,R1-24,R1-23,R1-20, R1-18,R1-14
0008	SF00083	transistor	MMBT5551LT1G(SOT23)/(ON)	1
0009	SG00558	integrated circuit-RS	4580M(SOP8)/(YW)	IC1-1
0010	HB02258	PCB-RS	D3-FR VER060801	
0011	AC00179	tin without lead-RS	M705E Sn 3Ag-0.5Cu	
0054	HK07780	PC board	P-D3-LED	
0001	HA01619	wire-RS	2P-2P 220mm UL1007 24AWG	
0002	HK07840	PC board	P-D-3 LED-SMD	
0001	HB02259	PCB-RS	D-3-LED VER060721	
0002	SE00067	SMD L.E.D	blue 12-215/BHC-AN1P2/3C	DL1,DL3
0003	RD00018	1/8W	1.0K_ ±5% 0805	DL2,DL4
0004	AE00449	solder material without lead	9308/Sn Ag Cu	
0003	AC00179	tin without lead-RS	M705E Sn 3Ag-0.5Cu	
0055	HK07781	PC board	P-DAMP-JK	
0001	HB02257	PCB-RS	DIGMOD OUTPUT-JK VER061107	
0002	HC00077	connector(male)	3P 2.5mm 180°	CON7,CON8,CON9
0003	HC00174	connector(male)	4P 3.96mm 180°	CON6
0004	HC00945	terminal block-RS	2ESDCR-02P PH5.08mm	CON1,CON5
0005	HC00947	terminal block-RS	2ESDCR-05P PH5.08mm	CON2,CON4
0006	HC00946	terminal block-RS	2ESDCR-04P PH5.08mm	CON3
0007	AC00179	tin without lead-RS	M705E Sn 3Ag-0.5Cu	
0056	HK07782	PC board	P-D4 FAN POWER	
0001	HB02301	PCB-RS	D4 FAN POWER VER060915	
0002	TC00382	transformer-RS	PT-LFB4185 115/230V(EI-41)	PT1
0003	SD00032	integrated circuit	LM317T(TO220)/(ST)	U1
0004	SA00167	bridge rectifier	2A W2-04	D3
0005	SA00098	rectifier diode	1A/400V IN4004	D1
0006	SA00105	zener diode	1W 12V 1N4742	D4
0007	CB00256	electrolytic capacitor	1000uF/25V ϕ10*20mm 5mm	C1



Stage	Part No.	Description	Specification	
0008	CB00188	electrolytic capacitor	10uF/63V $\mu$ 5*11mm 2.5mm	C3
0009	CB00053	electrolytic capacitor	100uF/16V $\mu$ 6*7mm	C4
0010	CA00082	ceramic capacitor	0.1uF SL	C2
0011	RA01109	fixed resistor 1/4W	1.0K <sub>⊥</sub>	R5
0012	RA00215	fixed resistor 1/4W	1.2K <sub>⊥</sub> M type	R4
0013	RA00157	fixed resistor 1/4W	0.0 <sub>⊥</sub>	R3
0014	HC00076	connector(male)	2P 2.5mm 180°	R1,R2,CN3,CN4
0015	HC00324	connect terminal	6.5m/m (PC250)	P1,P2,P3
0016	NI04152	LOCK-RS	LOCK-150 white	
0017	MI00256	heat-sink	25*15*10.6-1PIN SCL-2020	
0018	NI02249	plastic washer	TW-1(TO-220)	
0019	NC00005	mica	SB-9500DSP 18*13*0.1t V1.0	
0020	MG00616	screw	M3*6*0.5PH	
0021	AC00179	tin without lead-RS	M705E Sn 3Ag-0.5Cu	
0057	HK07783	PC board	P-D4-OUT	
0001	MJ00942	fixed bracket	CS12/600 V1.3	
0001	MJ00061	iron board	1*2135*1220 20.45kg	
0002	HA01925	jump	10mm	J2
0001	HA02249	wire	$\mu$ 0.6 tin-plating	
0003	HC00949	speaker socket-RS-C	LD4015	XL-1,XL-2
0004	AC00179	tin without lead-RS	M705E Sn 3Ag-0.5Cu	
0005	HB02270	PCB-RS	D4OUTPUT VER061005	
0058	HK07495	PC board	P-DGM1000(D1)-DIP	
0001	SD00066	integrated circuit	L7812CV(TO220)/(ST)	U13/B
0002	HC00389	connector(male)	16P 2.54mm180°	CN13
0003	HD00079	ceramic tube fuse	4A250V $\mu$ 5.2*20mm CSA/S/T/UL/VDE	F1A
0004	HC00276	connector(male)	3P 2.54mm 180°	CN4,CN10
0005	HC00034	short circuit connector	NO.2700 2.54mm/6mm OPEN	JR1,JR2,JR3,JR4
0006	CF00022	metal-film capacitor MSC	0.022uF/100V 5% CASE01	C14,C20,C99,C100
0007	CF00016	metal-film capacitor MSC	0.01uF/100V 5% CASE01	C10
0008	HA01919	jump	5mm	JP5
0001	HA02249	wire	$\mu$ 0.6 tin-plating	
0009	CB00038	electrolytic capacitor	47uF/16V $\mu$ 5*7mm	C84,C85
0010	CH00027	laminated capacitor	0.1uF/100V X7R PH5mm	C60,C59,C71,C72
0011	MB04575	chassis	DigiMod 3.0t*51*122*216(ME000155) V1.1	MEC1
0001	MB04577	chassis	DigiMod	
0001	MB04654	chassis	DigiMod 3.0t*51*122*216(ME000155) V1.1	
0001	MJ00057	AL plate-RS	3.0t*2000*1000mm 16.32kg	
0002	ME00220	iron pillar	M4*8*0.7PH V1.0	
0003	ME00221	iron pillar	M3*4*0.8PH V1.0	

Stage	Part No.	Description	Specification	
0012	MG00161	screw	M3*6	
0013	MK00115	spring-RS-C	1.0T*7.6*13*34.2(ML00004) V 1.2	ML1,ML2,ML3,ML4,ML5,ML6,ML7,ML8
0014	MC00801	top cover	DigiMod 1.0t*48*116*136.8(ME000156) V1.1	MEC2
0001	MJ01323	hot gradual zinc	1.0t*2135*1220 20.45kg V1.0	
0002	ME00222	iron pillar	M3*4*0.5PH	
0015	TC00330	transformer-RS	EE42/20(TO000068)	T3
0001	NI04468	creel stand-RS-ACT	FE0252(MILES PLATTS)	
0002	TC00386	transformer-RS	EE42/20(TO000068)	
0016	CB00322	electrolytic capacitor-RS	820uF/35V 105 WL u 10*30mm(JAMICON)	C47,C49,C50
0017	HC00866	row-wire header(MICRO-	72P 1.27mm 180°(AMP:5822021-4)	CN8
0018	HC00857	terminal block-RS	4P 2EHDV-04P male	CN14
0019	HC00359	connector	2.54 180° 4P(gold-plated) 6/11.6mm	CN17,CN18
0020	HC00858	terminal block-RS	2P 2EHDV-02P male	CN3,CN7
0021	HC00859	terminal block-RS	2P 7EHDV-02P male	CN1,CN2
0022	HC00856	terminal block-RS	5P 2EHDV-05P male	CN11,CN12
0023	NC00980	Silicone insulator-RS	1.0t*25mm*30mm	GAPAD1
0024	HC00082	connector(male)	8P 2.5mm 180°	CN16
0025	CN00180	RS	1.90uH~2.30uH/T50-2(TO000061)	L1,L2
0026	SD00318	integrated circuit-RS-C	TC4423EPA(PDIP8)/(MICROCHIP)	U7,U8,U9,U10,U15
0027	SD00317	integrated circuit	NJM7912FA(TO220F)/(JRC)	U14/B
0028	SA00309	high speed diode-RS	BYW51FP-200(TO220AB)/(ST)	D11,D12,D13
0029	AC00179	tin without lead-RS	M705E Sn 3Ag-0.5Cu	
0030	RA01614	chassis bracket 5W	4.7 ±5% SQM type	R73,R79
0031	MG00692	screw-RS	M3*12*0.5PH	VT3,VT4,VT7,VT8,VT13,VT14,VT15,VT16,VT20,VT24,VT28
0032	ME00226	screw-RS	M3*0.5PH	DD2,DD3,DD4,DD5,DD6,DD7,DD8,DD9,DD10,DD11,DD12
0033	MG00694	screw-RS	M2.9*9.5	VT2,VT6,VT11,VT18,VT22,VT26
0034	MG00693	screw-RS	M3*6*0.5PH	VT1,VT5,VT9,VT10,VT17,VT21,VT29,VT30
0035	SA00316	bridge rectifier-RS	8A GBU-8K/(PANJIT)	D1
0036	NE16112	lable	K-SERIES V1.0	
0001	NI00020	membrane	0.07*1M	
0002	NH00015	bond paper	0.075*1M	
0037	NC01179	insulator spacer-RS	0.13t*40mm*55mm(HI-FLOW-625)	SPAD1,SPAD2,SPAD3
0038	HK07198	PC board-RS	P-DGMFILT14(TO000062)	SM1,SM2
0001	HC00855	connector-RS	6/14.4/19.5	J1,J2
0002	AC00179	tin without lead-RS	M705E Sn 3Ag-0.5Cu	
0003	NI00218	cable tie	ALT-102SB	
0004	CN00179	RS	25.344uH±15%/T130-2(TO000062)	
0005	HB02094	PCB-RS	DGMFILT14 VER060411	

Stage	Part No.	Description	Specification	
0039	HC00879	connector(male)-RS	2*5P 3.0mm 180°(C3030WV-F-2*5P)	CN15
0040	HK07158	PC board	P-DGM500-1000/CNTRL17-DIP	
0001	SC00319	crystal oscillator	12.288MHZ	Y1
0002	HK07274	Photodiode	P-photosensitive resistance+u3lled	D5,D105
0001	RH00020	photosensitive resistance	VT90N1	
0002	SA00305	L.E.D-RS	u3 circle red high intensity	D5,D105
0003	NI02405	sleeve	u5*15mm	GU1,GU2
0001	NI00258	sleeve	u5*1000mm	
0003	AC00179	tin without lead-RS	M705E Sn 3Ag-0.5Cu	
0004	HK07159	PC board	P-DGM500-1000/CNTRL17-SMD	
0001	SG00045	SMD integrated circuit	BU4081BF(SOT73)/(PHI)	U6/B
0002	SF00030	SMD transistor-RS-ACT	BC817(SOT23)/(PHI)	Q1,Q2/B
0003	RD00298	SMD precise resistor 1/10W	47.0 $\pm$ 1% 0603	R17,R19,R22,R34,R41,R87, R117,R119,R134,R141, R187
0004	RD00201	SMD precise resistor 1/10W	1.50K $\pm$ 1% 0603	R6,R13,R65,R113,R165
0005	RD00292	SMD precise resistor 1/10W	1.00M $\pm$ 1% 0603	R10,R60,R98,R99,R100,R110, R200, R209,R210
0006	SG00001	SMD integrated circuit	TL074CDT(SO14)/(ST)	U3/B,U103/B
0007	SE00025	SMD diode	0.45A/85V BAV99	D6,D7,D106,D107
0008	SE00027	SMD diode	0.45A/85V BAW56	D1,D2,D3,D101,D102
0009	SE00026	SMD diode	0.45A/85V BAV70	D110,D111,D4,D11,D9,D10, D109
0010	RD00320	SMD precise resistor 1/4W	12.0K $\pm$ 1% 1206	R74/B,R85/B,R174/B,R185/B
0011	RD00341	SMD precise resistor 1/10W	4.70K $\pm$ 1% 0603	R28,R45,R90,R128,R145,R1002
0012	RD00322	SMD precise resistor 1/10W	2.70K $\pm$ 1% 0603	R7,R8,R16,R75,R79,R80,R83, R107,R108,R116,R175,R179, R180, R183
0013	RD00339	SMD precise resistor 1/10W	47.0K $\pm$ 1% 0603	R4,R31,R33,R43,R104,R131, R133,R143
0014	RD00342	SMD precise resistor 1/10W	1.50M $\pm$ 1% 0603	R38,R138
0015	RD00332	SMD precise resistor 1/10W	680 $\pm$ 1% 0603	R68,R168

Stage	Part No.	Description	Specification	
0016	RD00214	SMD precise resistor 1/10W	10.0K $\pm$ 1% 0603	R1,R5,R14,R24,R29,R30,R32,R39,R47,R48,R49,R50,R51,R52,R53,R54,R55,R56,R57,R69,R114,R129,R130,R132,R139,R147,R148,R149,R150,R151,R152,R153,R154,R155,R156,R157,R169,R201,R202,R219,R301,R302,R319,R1001, R1003
0017	RD00218	SMD precise resistor 1/10W	15.0K $\pm$ 1% 0603	R9,R12,R86,R109,R112,R186
0018	RD00224	SMD precise resistor 1/10W	100K $\pm$ 1% 0603	R35,R58,R59,R135,R158,R159,R208, R308
0019	RD00506	SMD precise resistor 1/10W	3.30K $\pm$ 1% 0603	R23,R27,R36,R81,R82,R136,R181,R182
0020	RD00509	SMD fixed resistor 1/10W	24K $\pm$ 5% 0603	R25
0021	RD00399	SMD precise resistor 1/4W	10.0K $\pm$ 1% 1206	R215/B,R216/B,R315/B,R316/B
0022	RD00282	SMD precise resistor 1/10W	1.00K $\pm$ 1% 0603	R2,R21,R44,R61,R62,R63,R64,R66,R67,R92,R93,R95,R102,R144,R161,R162,R163,R164,R166,R167
0023	RD00390	SMD precise resistor 1/10W	10.0M $\pm$ 1% 0603	R96,R97
0024	RD00392	SMD precise resistor 1/10W	2.20K $\pm$ 1% 0603	R15,R26,R46,R78,R115,R146,R178
0025	RD00105	SMD fixed resistor 1/10W	22K $\pm$ 5% 0603	R94
0026	RD00129	SMD fixed resistor 1/4W	0.0 $\pm$ 5% 1206	C34,C134
0027	RD00525	SMD precise resistor 1/10W	33.0K $\pm$ 1% 0603	R42,R142
0028	RD00301	SMD precise resistor 1/10W	12.1K $\pm$ 1% 0603	R11,R111
0029	CI00125	SMD ceramic capacitor 1210	10uF/16V Y5V-1210(3225)	C16,C31,C40,C116,C131
0030	CI00105	SMD ceramic capacitor 1206	0.0022uF/50V NPO $\pm$ 5%	C30,C130
0031	CI00185	SMD ceramic capacitor 0603	0.1uF/50V X7R $\pm$ 10%(C1608X7R1H104KT)/TDK	C6/B,C2,C4,C9,C11/B,C14,C17/B,C19/B,C20/B,C21/B,C24/B,C25/B,C27/B,C39,C49,C102,C104,C106/B,C117/B,C119/B,C120/B,C121/B,C124/B,C125/B,C127/B
0032	CI00053	SMD ceramic capacitor 0603	33PF/50V C0G $\pm$ 5%(C1608C0G1H330JT)/TDK	C10,C12
0033	CI00083	SMD ceramic capacitor 0603	3.9PF/50VC0G $\pm$ 0.25PF(C1608C0G1H3R9CT)TDK	C23,C123
0034	CI00084	SMD ceramic capacitor 0603	4.7PF/50VC0G $\pm$ 0.25PF(C1608C0G1H4R7CT)TDK	C52/B
0035	CI00201	SMD ceramic capacitor 0603	0.01uF/50V $\pm$ 10%(C1608X7R1H103KT)/TDK	C15,C41,C42,C43

Stage	No.	Description	Specification	
0036	CI00224	SMD ceramic capacitor 0603	470PF/50V C0G ± 5%(C1608C0G1H471JT)/TDK	C22,C26,C36,C37,C122,C126,C136,C137
0037	CI00234	SMD ceramic capacitor 0603	0.0033uF/50VC0G± 5%(C1608C0G1H332JT)/TDK	C13
0038	CI00220	SMD ceramic capacitor 0603	220PF/50V C0G ± 5%(C1608C0G1H221JT)/TDK	C1,C33,C133
0039	CI00216	SMD ceramic capacitor 0603	82PF/50V C0G ± 5%(C1608C0G1H820JT)/TDK	C7,C8,C107,C108
0040	CI00228	SMD ceramic capacitor 0603	0.001uF/50V C0G± 5%(C1608C0G1H102JT)/TDK	C5,C28,C105,C128
0041	CI00222	SMD ceramic capacitor 0603	330PF/50V C0G ± 5%(C1608C0G1H331JT)/TDK	C3,C32,C103,C132
0042	SE00077	SMD L.E.D-RS	red KPTC-2012EC	D119,D19
0043	SE00078	SMD L.E.D-RS	green KPTC-2012SGC	D16,D17,D18
0044	HB01991	PCB-RS	DGMCNTRL17 VER060411	CS1
0045	RD00592	SMD precise resistor-RS 1/10W	10.0K_ ±0.1% 0603	R72,R73,R88,R89,R172,R173,R188, R189
0046	RD00590	SMD precise resistor-RS 1/10W	1.50K_ ±0.1% 0603	R76,R77,R176,R177
0047	RD00591	SMD precise resistor-RS 1/10W	82.0K_ ±0.1% 0603	R70,R71,R170,R171
0048	AE00449	solder material without lead	9308/Sn Ag Cu	
0049	SE00090	SMD zener diode-RS	1/2W 6.8V(MMSZ5235B)(SOD-123)/(PANJIT)	D112,D114,D12,D14
0050	SG00496	SMD integrated circuit-RS	LF412CDR(SO8)/(TI)	U4/B,U104/B
0051	CO00137	SMD inductance-RS	1.0mH ±5%(NL453232T-102J)/(TDK)	L1,L101
0052	SG00502	SMD integrated circuit-RS	NE5532DR(SO8)/(TI)	U1/B,U2/B,U101/B,U102/B
0053	SG00504	SMD integrated circuit-RS-C	ATmega8-16AU(TQFP32)/(ATMEL)	U8/B
0054	SG00509	SMD integrated circuit-RS	HEF4069UBT(SO14)/(PHI)	U5/B,U105/B
0055	CI00278	SMD ceramic capacitor-RS 1206	0.0018uF/50V NPO ±5%	C29,C129
0005	NE16833	lable-RS	DIGIMOD1000 V1.0	
0001	NI00017	membrane	0.055*1M	
0002	NH00035	bond paper	0.06*1M	
0006	NE16889	lable-RS	DIGIMOD1000 V1.0	
0001	NI00017	membrane	0.055*1M	
0002	NH00035	bond paper	0.06*1M	
0007	NE16886	lable-RS	DIGIMOD1000 V1.0	

Stage	Part No.	Description	Specification	
0001	NI00034	membrane	0.045*1M	
0002	NH00014	bond paper	0.05*1M white	
0041	NI04389	plastic washer-RS	TW-20N	
0042	CF00226	metal-film capacitor-RS MKP	0.33uF/160V±5%(BFC237934334)	C63,C64,C65,C66
0043	SB00226	transistor-RS-CT	IRFP260NPBF(TO247)/(IR)	Q3,Q4,Q5,Q6
0044	CG00079	X1/Y2 capacitor-RS	0.0047uF/250V(S472M59Z5U563K7)	C8,C9,C7,C6
0045	CG00078	X2 capacitor-RS MKT	1.0uF/275V ±5%(BFC233620105)	C1
0046	CF00224	metal-film capacitor-RS MKP	0.1uF/630V±5%(BFC238320104)	C4,C5
0047	CF00222	metal-film capacitor-RS MKT	1.0uF/250V ±5%(BFC237341105)	C67,C68
0048	SB00221	transistor-RS-CT	BD237(SOT32)/(ST)	Q7
0049	SB00222	transistor-RS-CT	HGTG12N60A4D(TO247)/(FAIRCHILD)	Q1,Q2
0050	RA01654	5W	0.1_±5%/(AC05000001007JAC00)	R69,R70,R75,R76
0051	RH00032	thermistor-RS-NTC	10K±5%(NTCLE100E3103JB0)	R43,R44
0052	SB00227	Pohtotriode-RS-CT	CNY17F-2BNC(DIP6)/(FAIRCHILD)	U16
0053	CN00200	common inductance-RS-CT	2.3mH/4A EV28-4.0-02-2M3/(SCHAFFNER)	T1,T2
0054	CB00342	electrolytic capacitor-RS-ACT	220uF/200V ¼18*31.5mm (NICHICON)	C24,C25,C26,C27,C28,C29
0055	CB00343	electrolytic capacitor-RS-ACT	390uF/100V ¼16*31.5mm/(NICHICON)	C51,C52,C53,C54
0056	RA01659	metal-oxide-film resistor-RS 1/2W	240K±5% VR37(VR37000002403JA100)	R1
0057	CG00081	Y-type capacitor-RS-ACT	S20-K300(B72220301K101)/(EPCOS)	RV1
0058	NE16634	lable-RS-CT	DIGIMOD1000 V1.1	
0001	NI00039	adhesive label	0.06*1M	
0002	NI00017	membrane	0.055*1M	
0059	NE16636	lable-RS	POWERMODII350/65 V1.0	
0001	NI00017	membrane	0.055*1M	
0002	NI00039	adhesive label	0.06*1M	
0060	RH00034	thermistor-RS-CT	2.5_ B57237S259M/(EPCOS)	R10
0061	NI00280	sleeve	¼15*25mm	
0001	NI00278	sleeve	¼15*1000mm	
0062	HC00941	fuse drawer-RS-ACT	520101(5.2mm) PCB LITTLEFUSE	F1
0063	CG00082	X2 capacitor-RS-ACT	0.1uF/275V±20% R46-KI3100-JP M1M(ARC)	C137
0064	HK07157	PC board	P-DGM1000(PowerSoft)-SMD	
0001	SE00025	SMD diode	0.45A/85V BAV99	D18,D19,D20,D21,D26
0002	RD00255	SMD precise resistor 1/4W	100K_ ±1% 1206	R14,R15,R16,R17,R18,R19,R51 R52,R53,R54,R84,R85,R88,R89
0003	RD00245	SMD precise resistor 1/4W	1.00K_ ±1% 1206	R25,R28,R29,R49,R34,R50,R87

Stage	Part No.	Description	Specification	
0004	RD00399	SMD precise resistor 1/4W	10.0K <sub>±</sub> ±1% 1206	R11,R47,R48,R57
0005	RD00140	1/4W	4.7K <sub>±</sub> ±5% 1206	R12
0006	CI00095	SMD ceramic capacitor 1206	0.1uF/50V X7R	C31,C33,C34,C39
0007	CI00103	SMD ceramic capacitor 1206	100PF/50V NPO ±5%	C136
0008	CI00042	SMD ceramic capacitor 1206	0.001uF/50V NPO	C73,C74,C75,C76,C80,C81,C82 , C83,C92,C93,C94,C95
0009	CI00135	SMD ceramic capacitor 1206	33PF/50V NPO ±5%	C44
0011	CI00041	SMD ceramic capacitor 1206	470PF/50V NPO	C43
0012	HB01989	PCB-RS	DGMMAIN19 VER060411	CS1
0013	CI00263	SMD ceramic capacitor-RS 1206	0.0047uF/200V X7R ±10%	C12,C13,C15,C18,C19,C21
0014	RD00615	SMD precise resistor- RS 1/8W	1.50 <sub>±</sub> ± 5% 0805	R22,R23,R45
0015	RD00607	SMD precise resistor- RS 1/4W	330 <sub>±</sub> ± 1% 1206	R26,R27,R30,R31,R32,R33,R35 , R36,R80,R81,R82,R83
0016	RD00605	SMD precise resistor- RS 1/4W	4.70 <sub>±</sub> ± 1% 1206	R58,R59,R60,R61
0017	RD00608	SMD precise resistor- RS 1/4W	33.0K <sub>±</sub> ± 1% 1206	R13
0018	RD00606	SMD precise resistor- RS 1/4W	15.0 <sub>±</sub> ± 1% 1206	R20,R21
0019	RD00604	SMD precise resistor- RS 1/4W	47.0 <sub>±</sub> ± 1% 1206	R86
0020	SG00465	SMD integrated circuit-RS	M24C16WMN6TP(SO8)/(ST)	U12
0021	AE00449	solder material without lead	9308/Sn Ag Cu	
0022	SG00466	SMD integrated circuit-RS-ACT	HCPL-0611#060(SO8)/(AGILENT)	U3,U4,U5,U6
0023	SE00089	SMD zener diode-RS	1/2W 5.1V(MMSZ5231B)(SOD- 123)/(PANJIT)	D14,D15,D16,D17
0024	SF00101	voltage stabilized transistor-RS	L4941BDT-TR-PB FREE(DPAK)/(ST)	U11
0025	SG00495	SMD integrated circuit-RS-CT	IR2156SPBF(SO14)/(IR)	U1
0026	SE00095	SMD diode-RS-CT	ES3D(DO214AB)/(VISHAY)	D8,D9,D10
0027	SE00097	SMD diode-RS-CT	1A/400V US1G(DO214AC)/(VISHAY)	D3,D4,D22,D23,D24,D25,D28
0028	CI00279	SMD ceramic capacitor-RS 1206	0.0022uF/200Vx7R±10%	
0029	SE00098	C	1W 15V DL4744A MELF/(SJ)	D2,D27
0030	CO00138	SMD fixed inductance-RS-CT	4*0.47mH(B82792-C2474- N315/(EPCOS)	T10
0065	NE16887	lable-RS	POWERMOD V1.0	
0001	NI00015	membrane	0.04*1M	
0002	NH00013	bond paper	0.045*1M	
0066	HE00125	fan-RS	JST2P	

Stage	Part No.	Description	Specification	
0067	MG00782	screw-RS	M3*20	
0059	NI00218	cable tie	ALT-102SB	
0060	HC00876	terminal block-RS	7ESDP-02P	
0061	NI01627	fixed bracket	CM-19S	
0062	NE02448	label	green	
0001	NH00014	bond paper	0.05*1M white	
0002	NI00034	membrane	0.045*1M	
0063	RH00028	thermistor	500_ (NDA05C150L-W)	
0064	HI00140	RS	A0701HM-6A	
0001	NI04630	film-RS-CT	450*605*0.5mm 0.184kg_V1.0	
0066	NB05130	inner case-RS	D1 ALTO_V1.0	
0067	NB05133	carton-RS	D1 ALTO_V1.0	
0068	NB05129	cardboard-RS	D1 ALTO_V1.0	
0069	NE17034	lable-RS	D1_V1.0	
0001	NI00014	membrane	0.035*1M	
0002	NH00012	bond paper	0.04*1M	
0070	HI00362	power switch-RS	SS-160-7	
0071	HA04968	wire-RS	brown	
0072	HA04967	wire-RS	130/130mm UL1617 18AWG bule bule	
0073	NF02695	user manual-RS	D series_V1.1	
0001	NH00149	paper	889*640mm	
0074	NI04549	panel-RS	D1 7*88*430 PS 7798_V1.1	