

Service *Manual*

MODEL: ELVIS 12S/12M/15S

CONTENT

1. Introduction.....	1
2. Specification.....	2
3. Block Diagram.....	3
4. Schematic Diagram.....	5
5. PCB Layout.....	7
6. Exploded View & Mechanical Parts List.....	10
7. BOM.....	16

1. Introduction

These cabinets is designed for professional stage performance .Using density Particle Board and high quality carpet for the body of the cabinet made it more durable .The special handle shows unique Italy style. With the accurate crossover point made the timbre very clean.

ES12M adopt special horn in polypropylene reinforced. With wide directional angle $80^{\circ} \pm 10^{\circ}$ (1KHZ-16KHZ)and 180W AES/360W Peak power. Matching the ELVIS 12S/15S(SUB WOOFER) with ELVIS 12/15 made the acoustics of the cabinet clean and the bass strong. All these characters made it very suitable for any place.

2.Specification

Technical specification	ELVIS 12S
Power Handling	200W AES (rated power) /400W Peak (peak power)
Sensitivity (SPL 1W,1m)	97dB / 119dB
Frequency Response	50Hz ~ 20kHz ± 6dB
Impedance	4Ω Nominal
Crossover Frequency	125Hz
High-Frequency Crossover Type	
Low-Frequency Crossover Type	6dB/octave
LOW-Frequency High-Frequency	12"/318mm Woofer
Horn Coverage H -V	
Input Connectors	input/output Pin1+ ;Pin1-
Dimensions	H: 495 mm (19.5") W: 400mm(15.7") D: 455 mm (17.9")
Net Weight	51.15 lbs / 23.2kg
Shipping Weight	57.98 lbs / 26.3kg
Volume	6.15CFT

Technical specification	ELVIS 12 M (2-way)
Power Handling	180W AES(rated power) / 360W Peak(peak power)
Sensitivity (SPL 1W,1m)	97dB / 119 Max
Frequency Response	60Hz ~ 20kHz ± 6dB
Impedance	8 Ω Nominal
Crossover Frequency	2500Hz
High-Frequency Crossover Type	12dB/octave
Low-Frequency Crossover Type	12dB/octave
LOW-Frequency High-Frequency	12"/318mm Woofer 1" Compression Driver
Horn Coverage H -V	80° ± 10° (1kHz - 16kHz)
Input Connectors	input/link Pin1+ ;Pin1-
Dimensions	H:615 mm (24.2") W: 400 mm(15.7") D: 345 mm (13.5")
Net Weight	38.93 lbs /17.66 kg
Shipping Weight	46.29lbs /21 kg
Volume	6.10CFT

Technical specification	ELVIS 15S
Power Handling	300W AES(rated power) /600W Peak((peak power)
Sensitivity (SPL 1W,1m)	98dB / 122Max
Frequency Response	45Hz ~ 20kHz +/- 6dB
Impedance	4 Ω Nominal
Crossover Frequency	125Hz
High-Frequency Crossover Type	
Low-Frequency Crossover Type	6dB/octave
LOW-Frequency High-Frequency	15" /385mm Woofer
Horn Coverage H -V	
Dimensions	H: 565 mm(22.2") W: 455mm(17.9") D: 525 mm(20.6")
Net Weight	65.48 lbs / 29.7 kg
Shipping Weight	74.52 lbs / 33.8 kg
Volume	8.67CFT

3. Block Diagram

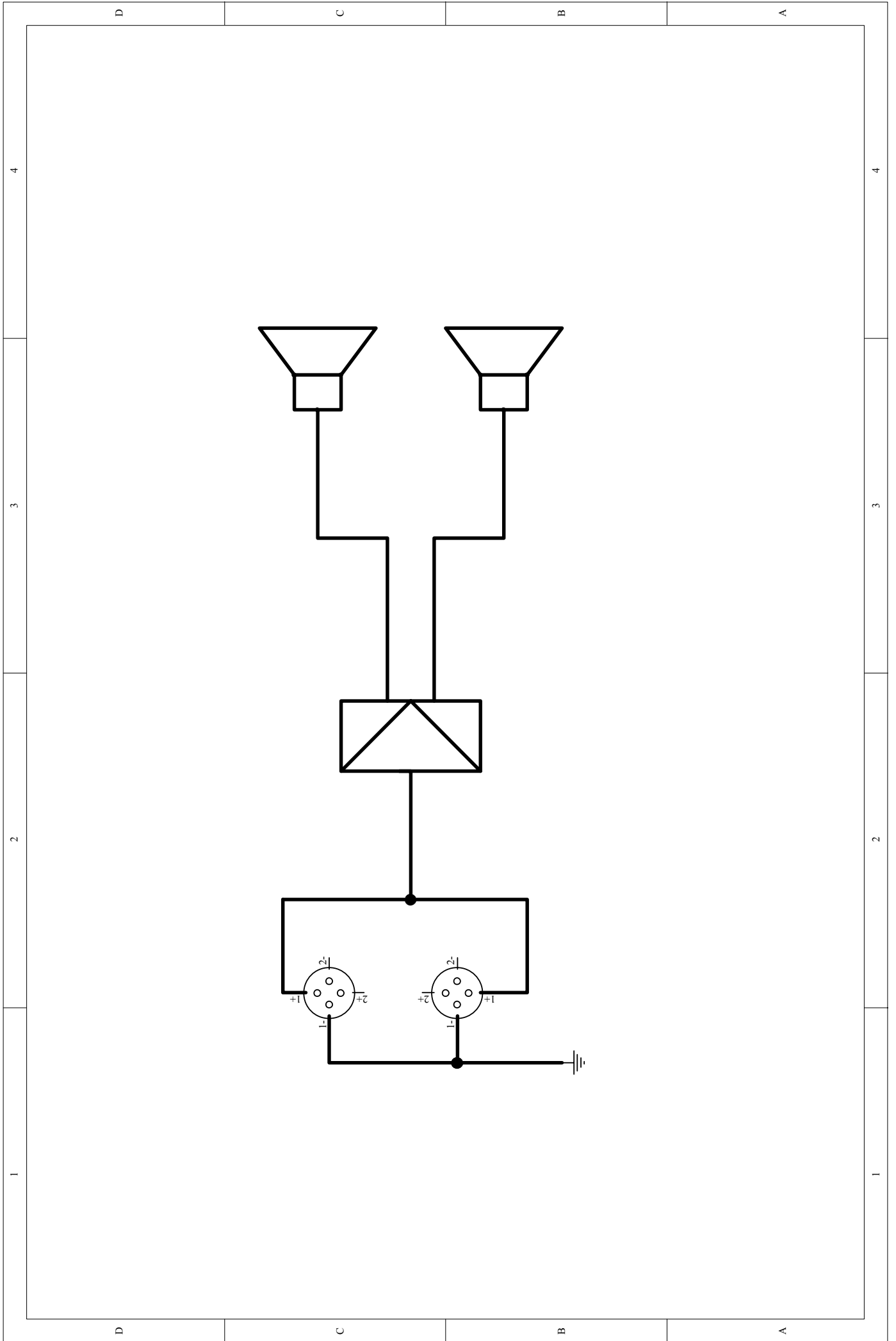

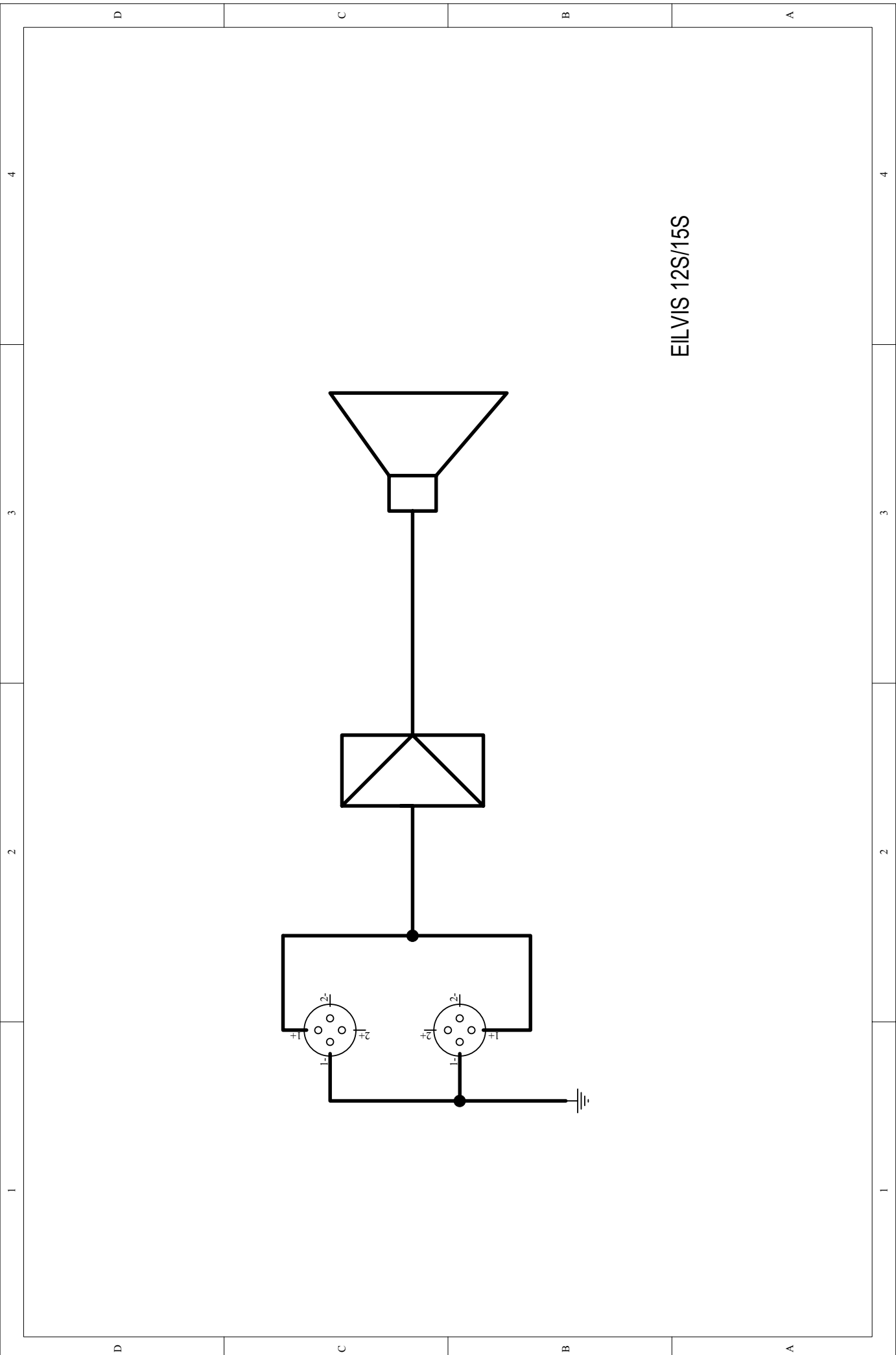

EILVIS 12S/15S

4. Schematic Diagram

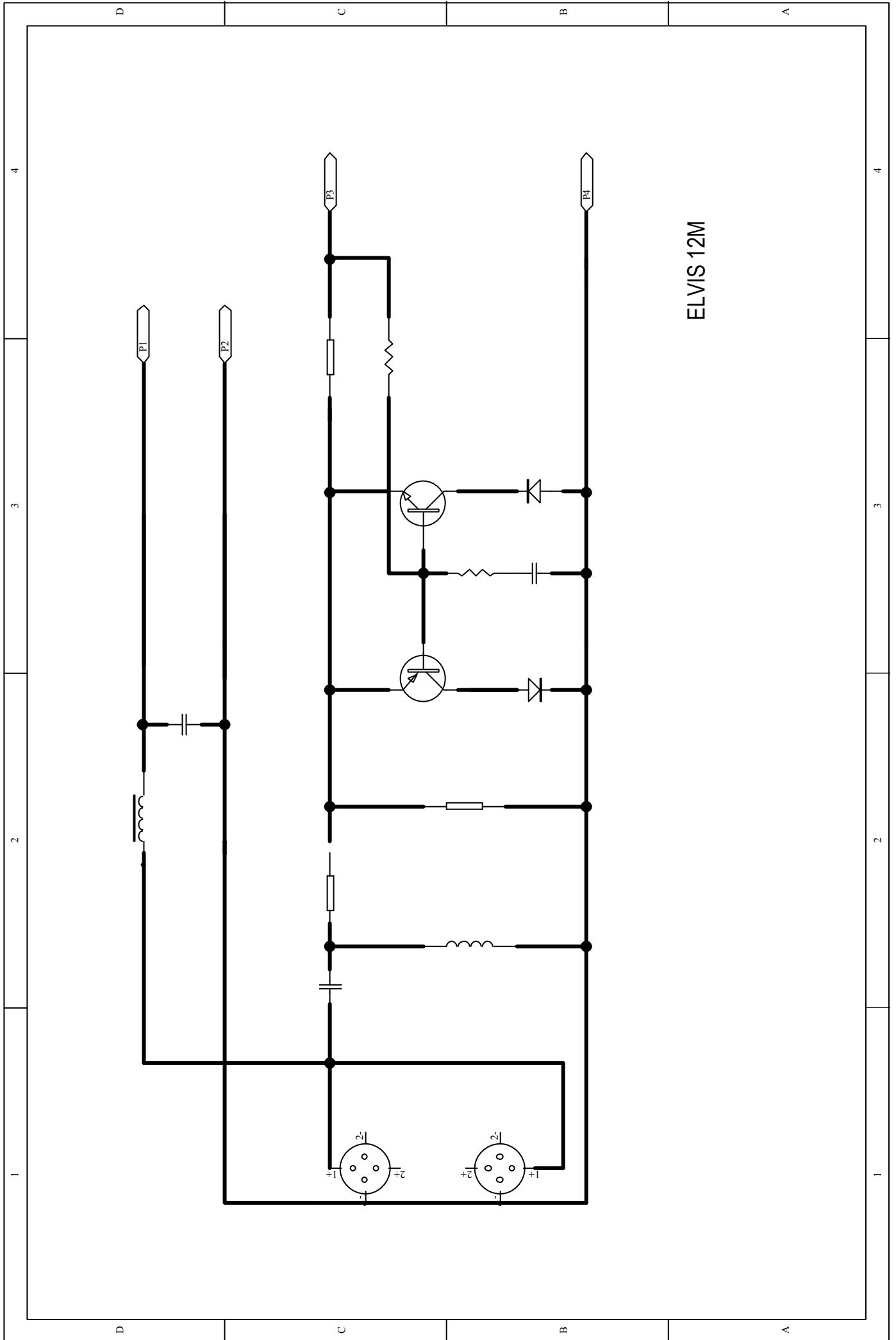

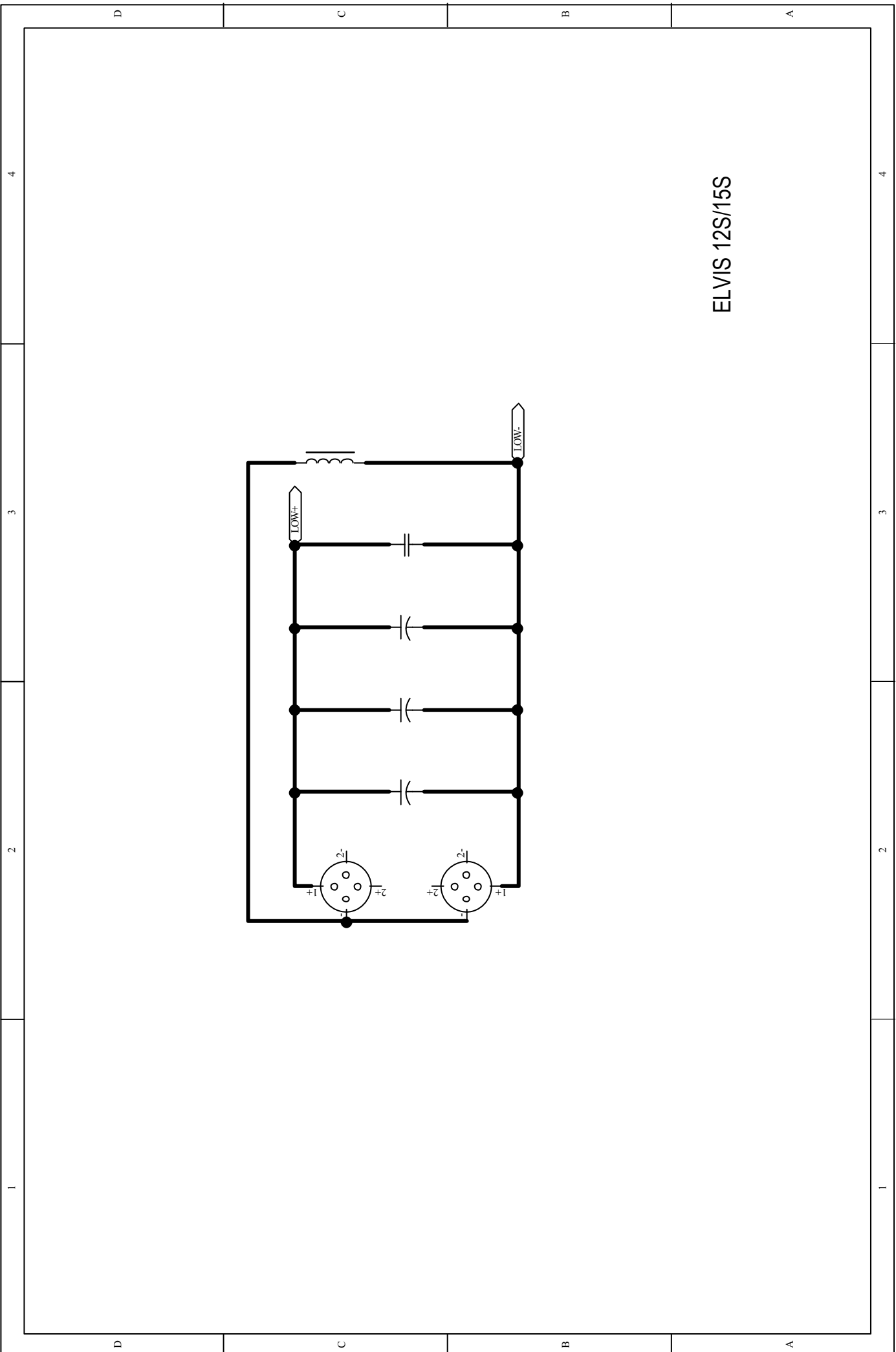

ELVIS 12S/15S

5. PCB Layout

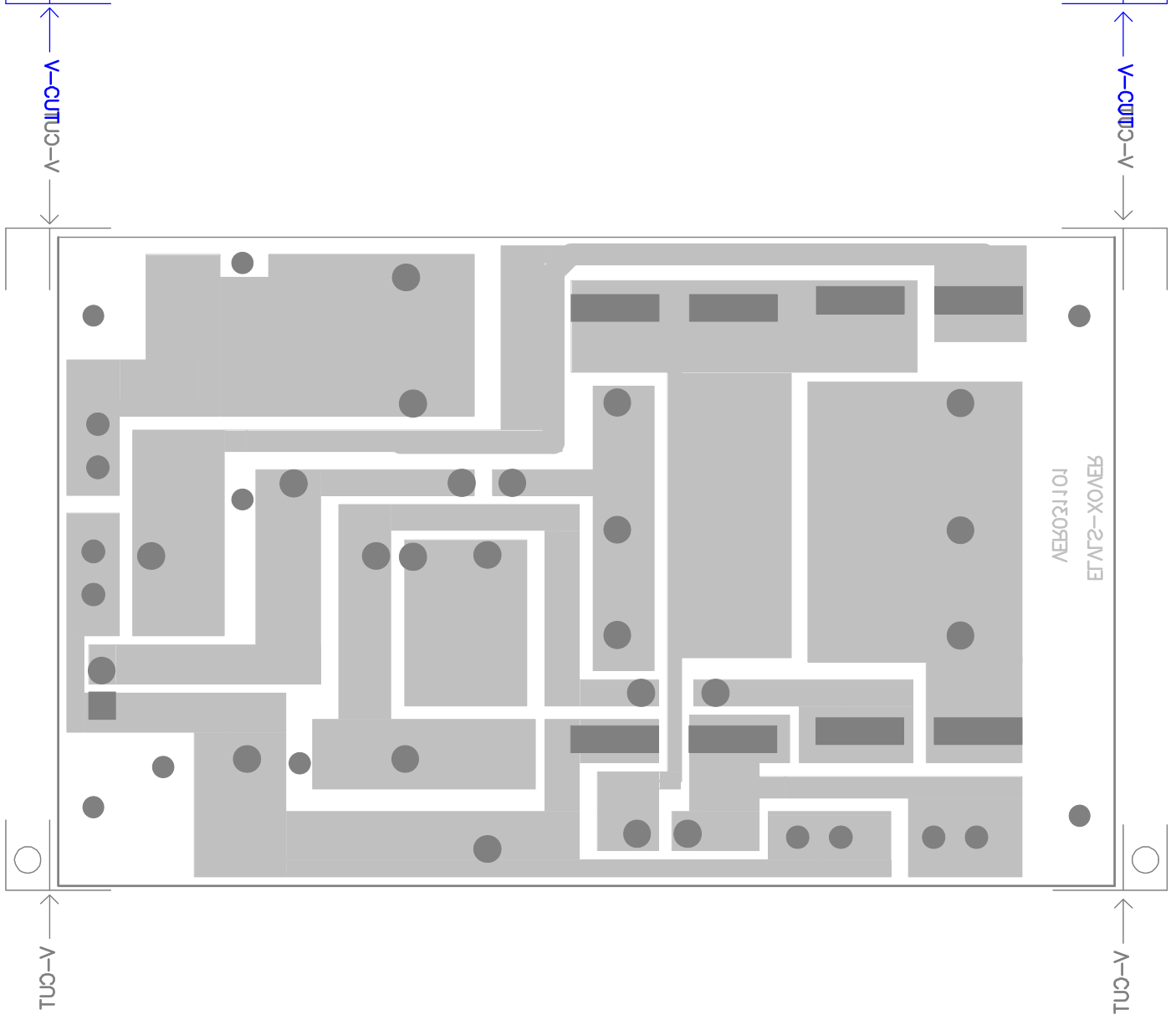
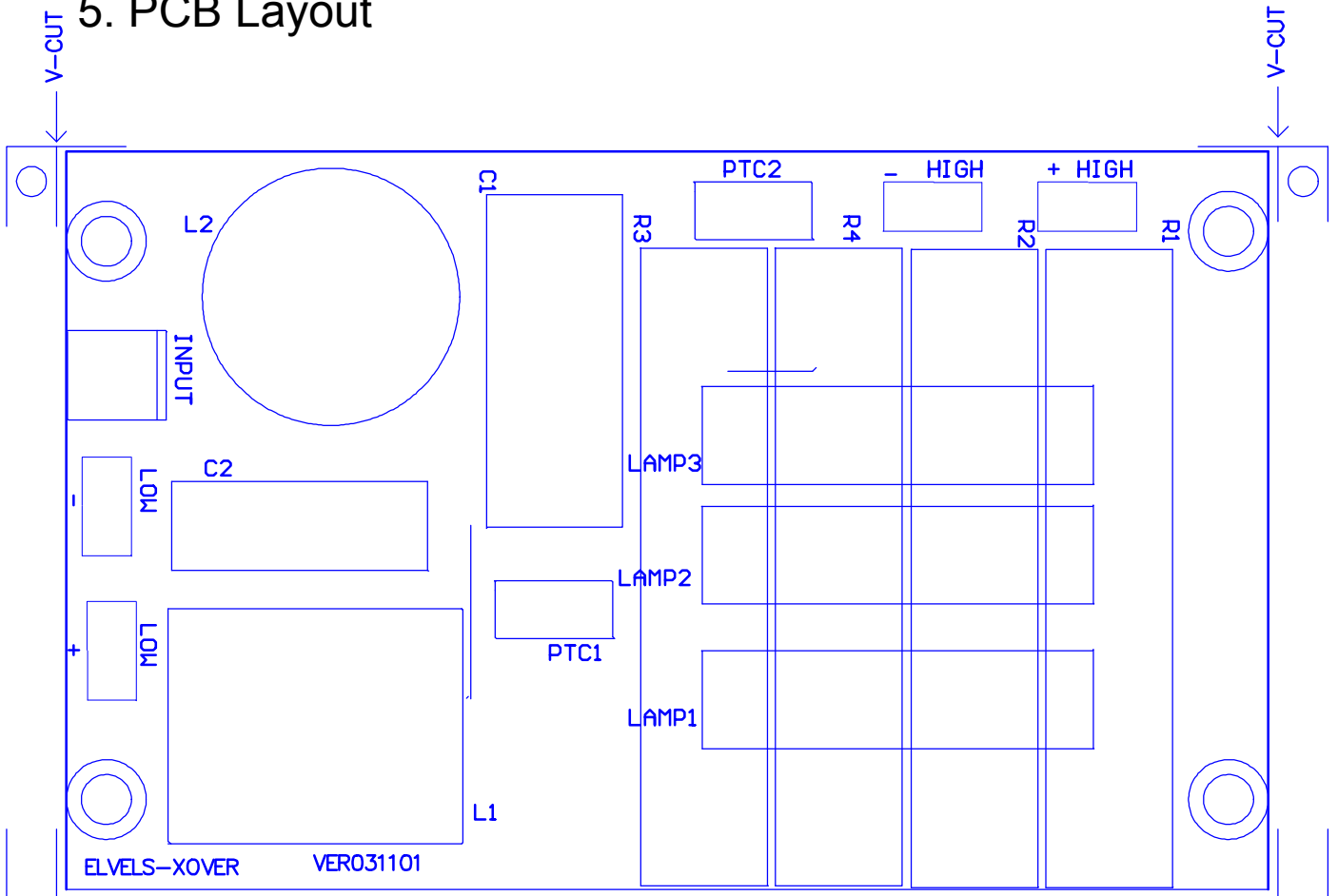

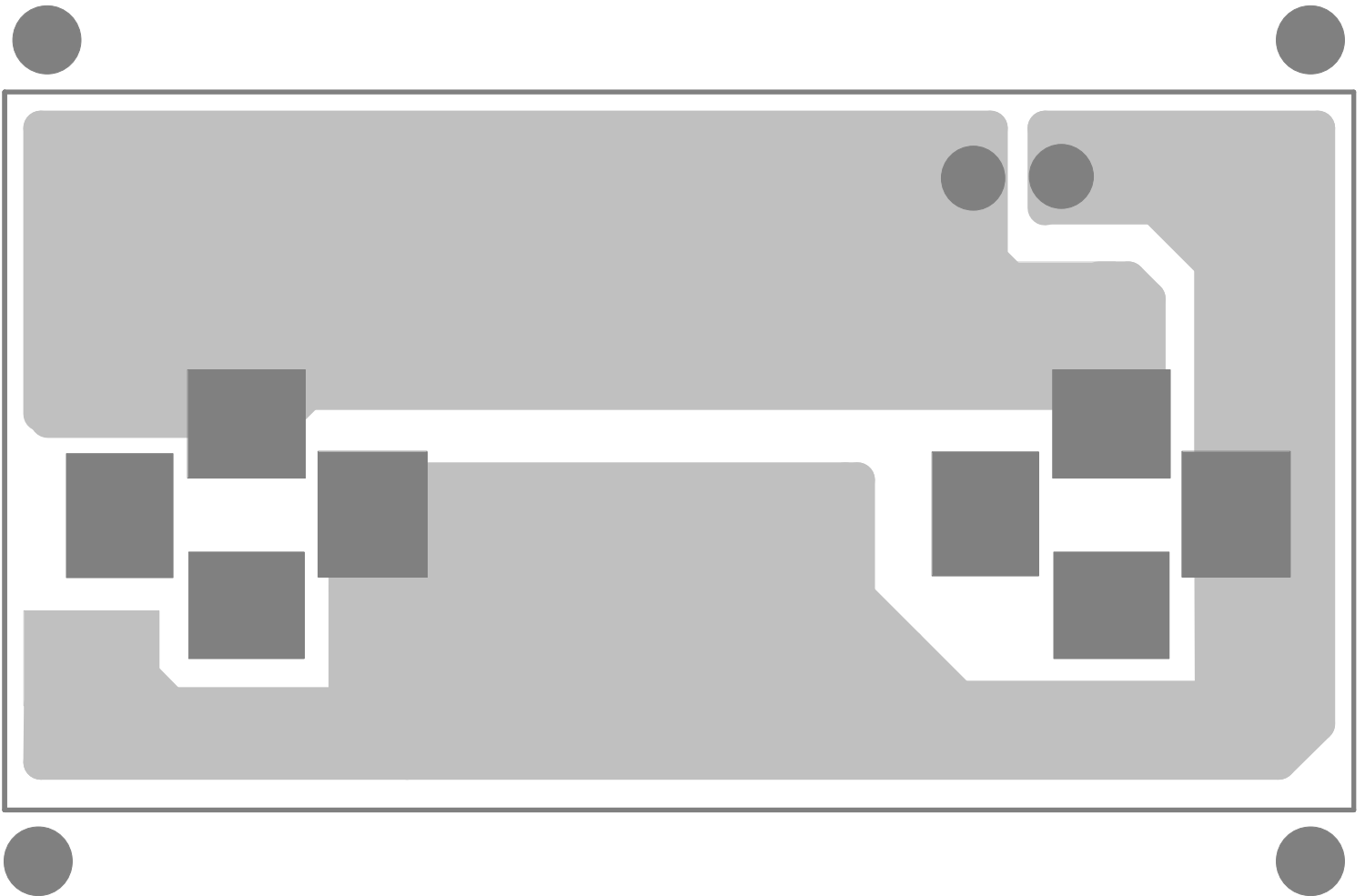
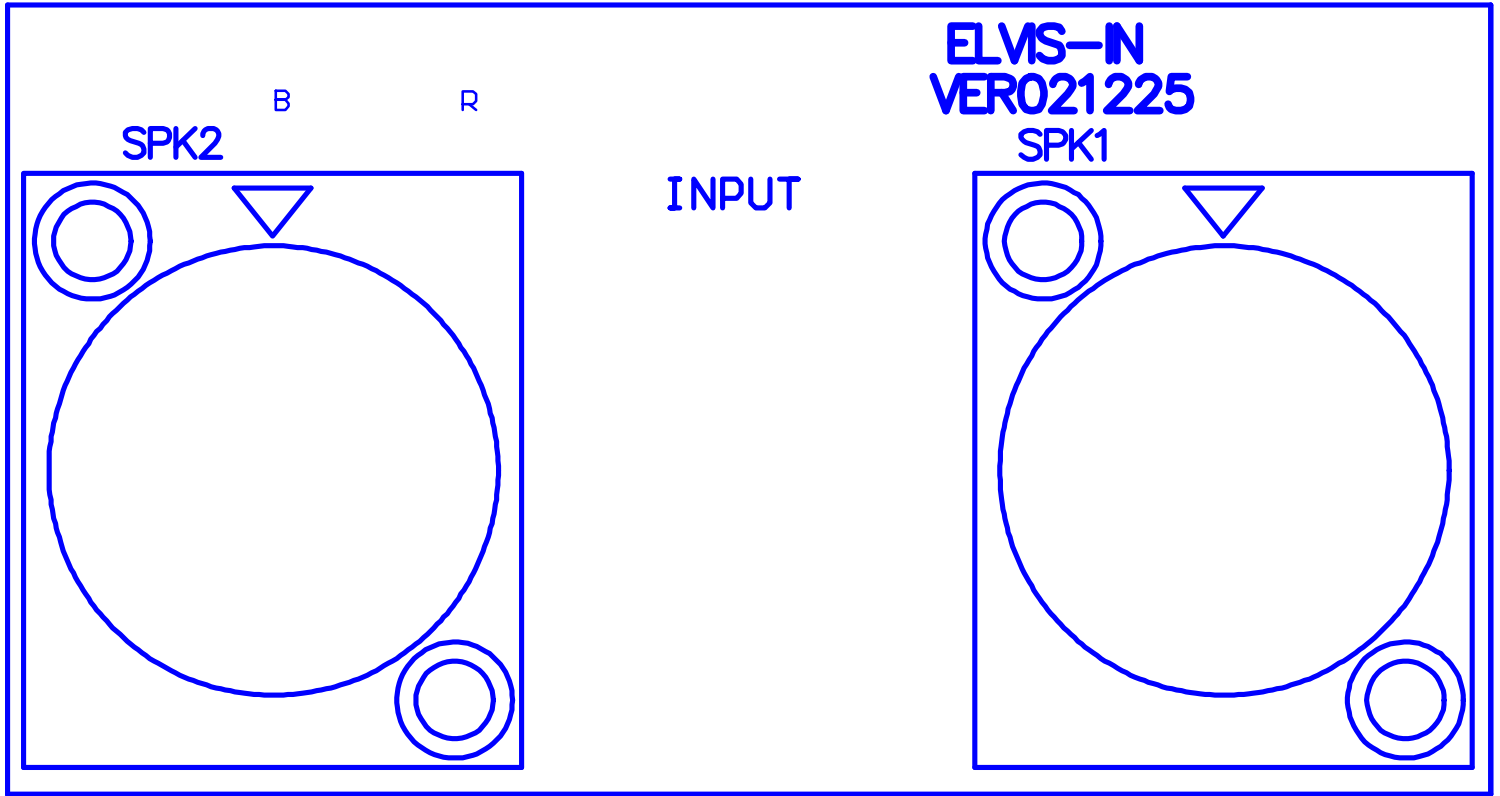

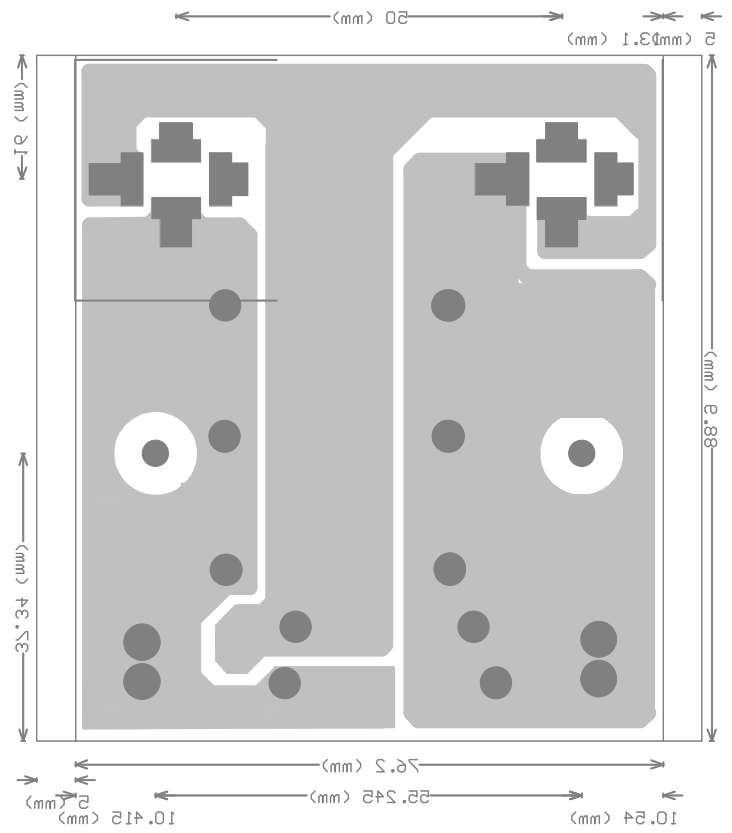
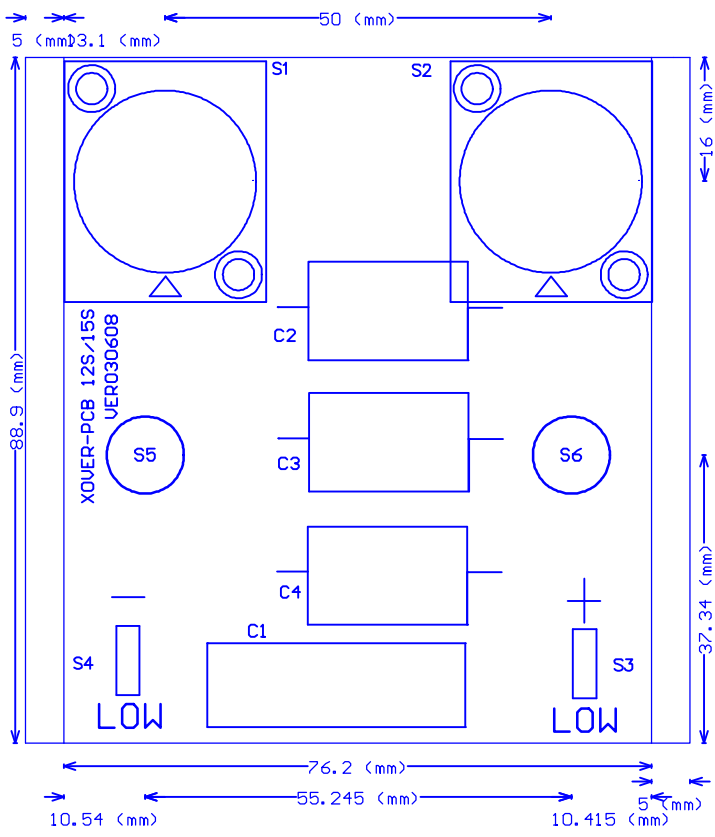

6.Exploded Views & Mechanical Parts List

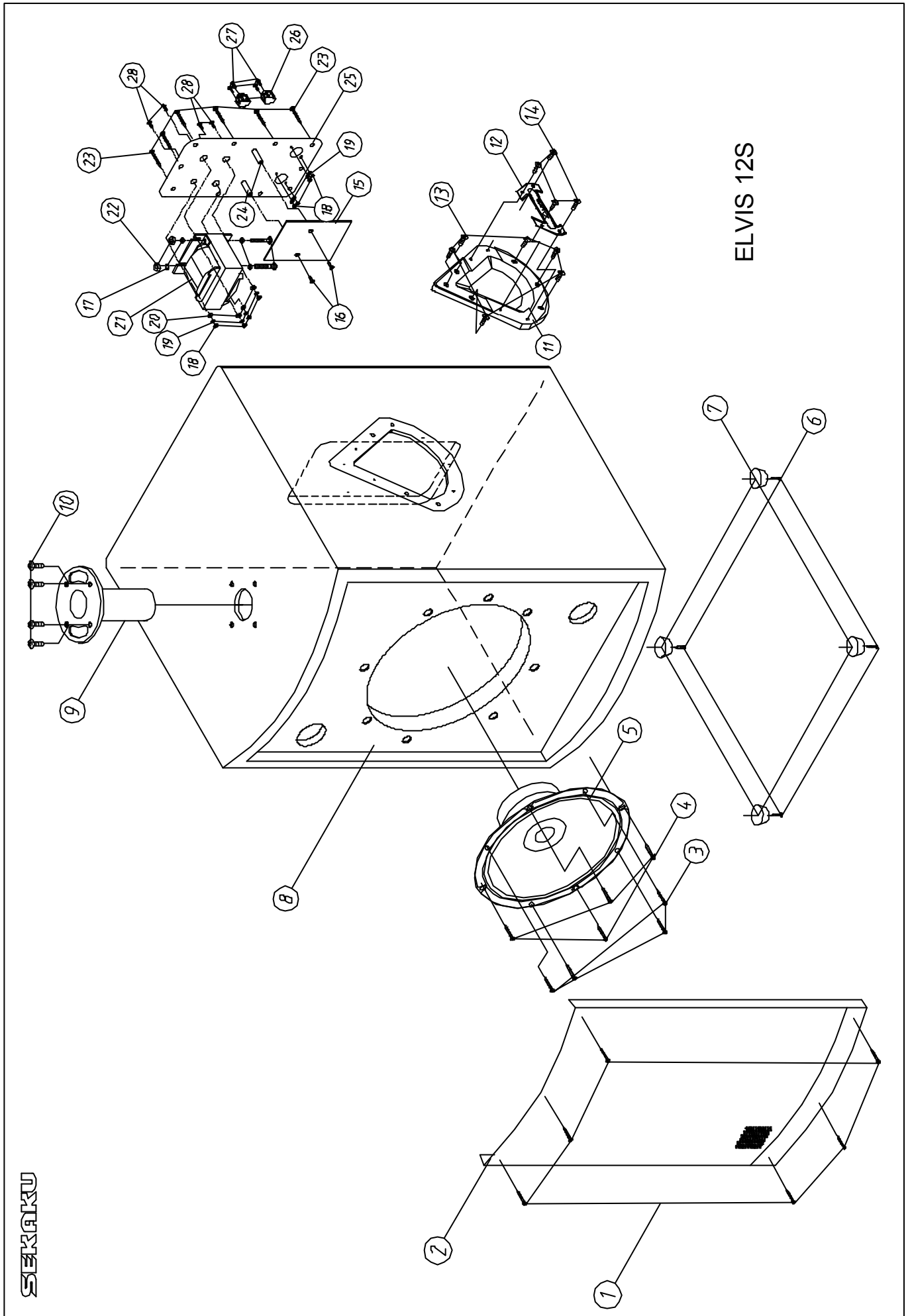

SEKURAKU

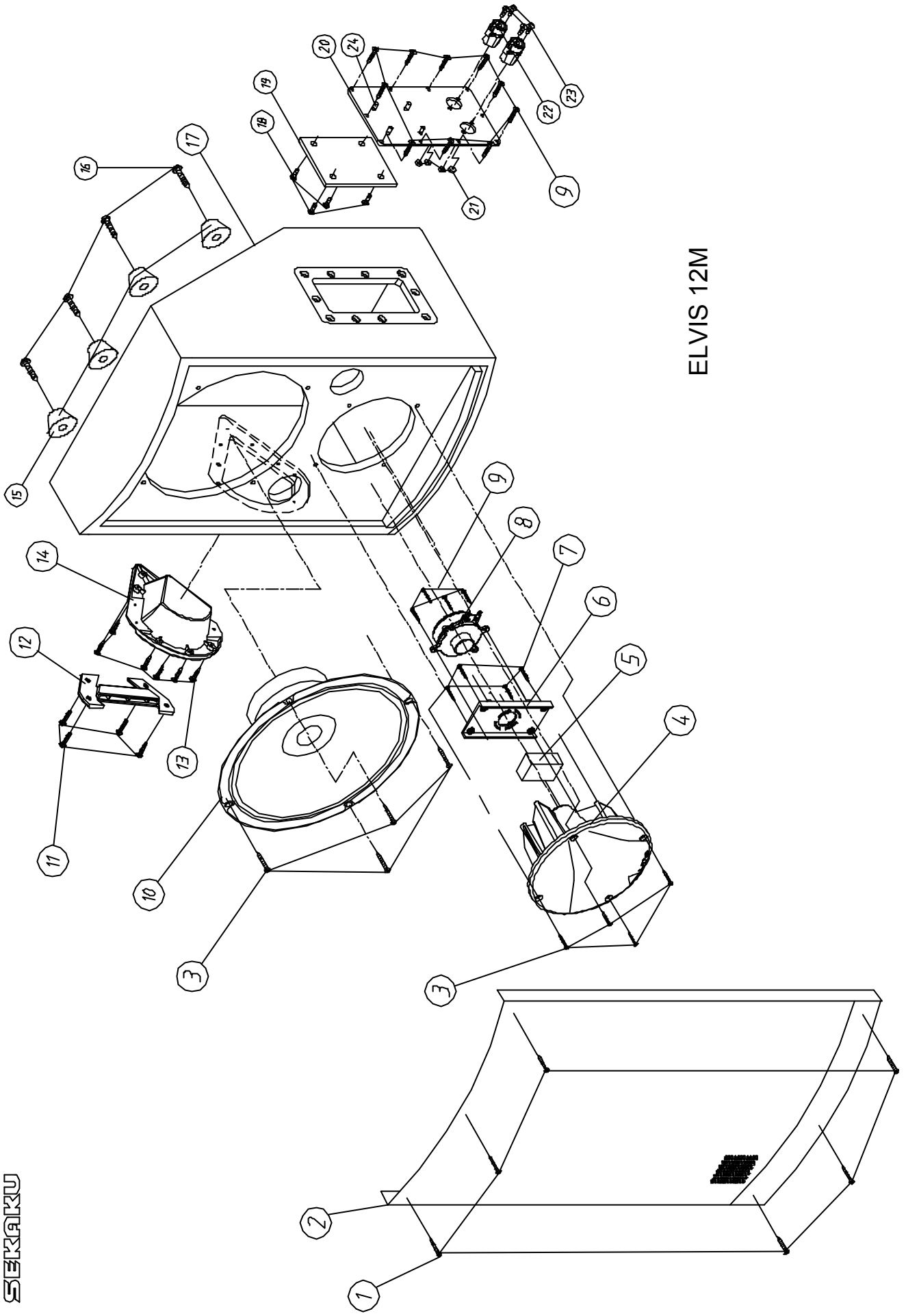

ELVIS 12M

SEKURAKU

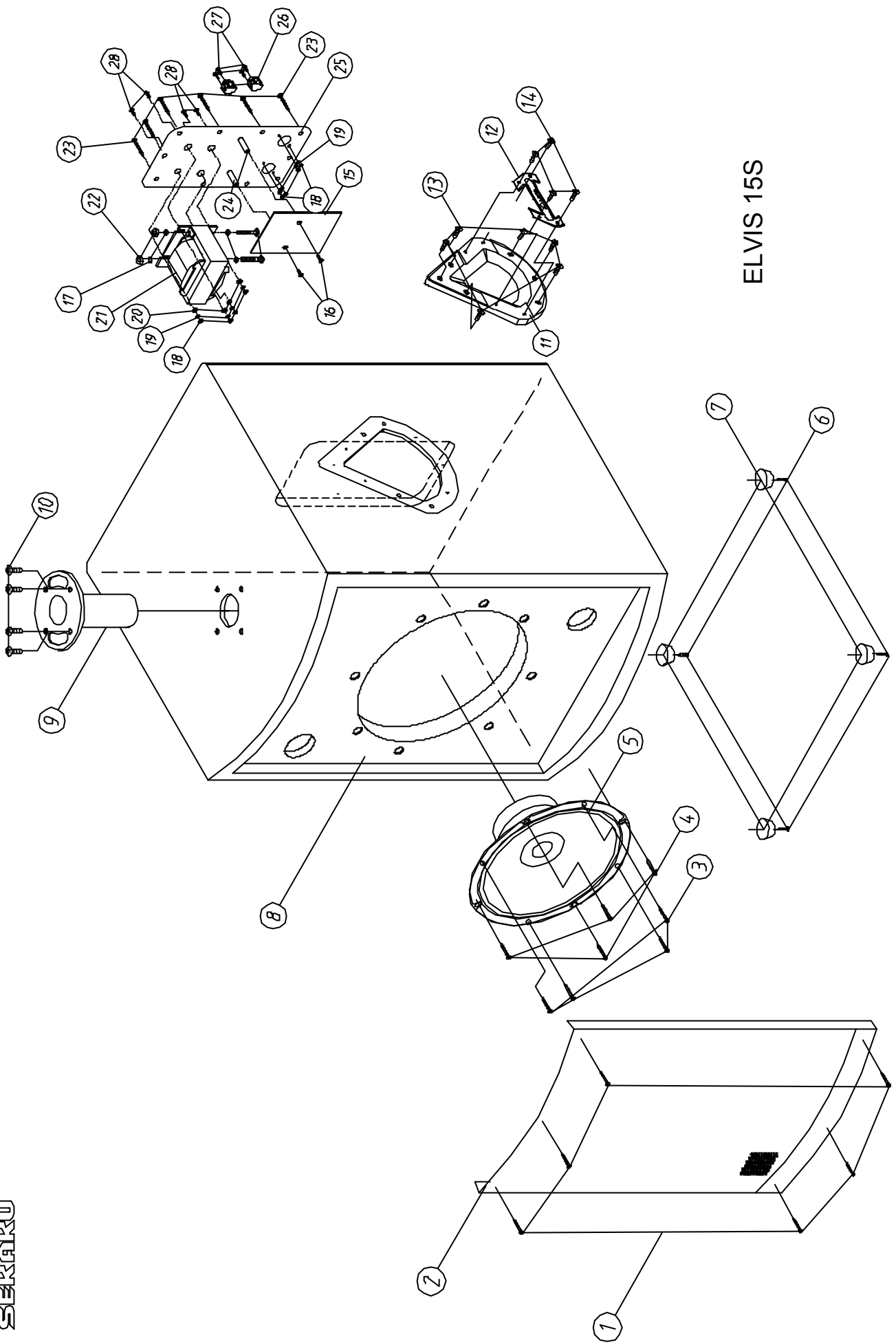

ELVIS 15S

Part List

ELVIS 12M

No.	Item No.	Item Description	Specification	PCS
1	MG00349	black-plated screw-T head $\phi 6$	M3*16	6
2	MD00425	grille	ELVIS12M	1
3	MG00450	black-plated screw-T head $\phi 10$	M5*30	8
4	NI02242	horn	ELVIS10,12,15 9023	1
5	ND00231	foam	10x50x50mm	1
6	NI02374	fixed board-ABS	70*135*10 9023	1
7	MG00352	black-plated screw-pill-iron plate	M4x25	4
8	HG00081	driver	PA-D597P-AUDIO 8 Ω	1
9	MG00351	black-plated screw-pill-iron plate	M4x16	14
10	HK03075	K-woofer(12")	Z00773_LP318.50/1100 WT 6 Ohm	1
11	MG00338	black-plated screw-T head $\phi 8$	M4x30mm	4
12	NI02376	handle-ABS	85.6*207*7 9023	1
13	MG00361	black-plated screw-pill-iron plate	M4*20mm	6
14	NI02375	handle cover-ABS	ELVIS10,12,15 9023	1
15	NI02426	foot curshion	$\phi 37 \times 15$	4
16	MG00360	black-plated screw	M4*25mm	4
17	NC00144	cabinet	ELVIS12M 12 inch	1
18	MG00060	black-plated screw-self tapping	M3x6	4
19	HK02379	K-PC board	ELVIS-XOVER VER021225	1
20	MJ01210	fixed board	ELVIS12M ALTO	1
21	ME00015	color nut	3MM	4
22	HC00218	speakon	SKCB201-4P connector female	2
23	MG00042	black-plated screw	M3x10	4
24	ME00105	iron pillar	M3*7.2*0.5PH	4

ELVIS 12S

No.	Item No.	Item Description	Specification	PCS
1	MG00349	black-plated screw-T head $\phi 6$	M3*16	6
2	MD00421	grille	ELVIS12-SUB	1
3	MG00350	black-plated screw-T head $\phi 10$	M5*30	4
4	HK03074	woofer	Z00780_LP	1
5	MG00360	black-plated screw	M4*25	4
6	NI02426	rubber foot	$\phi 37*15$	4
7	NC00143	cabinet	ELVIS12-SUB	1
8	MH00801	bracket	SK0004	1
9	MG00353	black-plated screw	M6*30	4
10	NI02375	handle cover	ELVIS12S/15S/12M/10	2
11	NI02376	handle	ELVIS12S/15S/12M/10	2
12	MG00361	black-plated screw-pill-iron plate	M4*20	12
13	MG00338	black-plated screw-T head $\phi 8$	M4*30	8
14	HB00968	PCB	XOVER-PCB 12S/15S	1
15	MG00020	black-plated screw-self tapping	M3*8	2
16	ME00015	color nut	3MM	8
17	MF00037	spring washer	$\phi 3*\phi 5*1T$	8
18	MF00023	color washer	$\phi 3*\phi 10*1T$	4
19	CN00061	crossover inductor	4.2mH($\phi 1.2$ mm E type)	1
20	MG00351	black-plated screw-pill-iron plate	M4*16	10
21	ME00093	iron pillar	hexagon 6.35*M3*28	2
22	MJ01206	fixed board	ELVIS12S ALTO	1
23	HC00218	speakon	SKCB201-4P connector female	2
24	MG00042	black-plated screw	M3*10	4
25	MG00364	black-plated screw	M3*12	4

ELVIS15S

No.	Item No.	Item Description	Specification	PCS
1	MG00349	black-plated screw-T head $\phi 6$	M3*16	6
2	MD00429	grille	ELVIS15-SUB	1
3	MG00350	black-plated screw-T head $\phi 10$	M5*30	4
4	HK03076	woofer	Z00822_LP	1
5	MG00360	black-plated screw	M4*25	4
6	NI02426	rubber foot	$\phi 37*15$	4
7	NC00145	cabinet	ELVIS15-SUB	1
8	MH00801	bracket	SK0004	1
9	MG00353	black-plated screw	M6*30	4
10	NI02375	handle cover	ELVIS12S/15S/12M/10	2
11	NI02376	handle	ELVIS12S/15S/12M/10	2
12	MG00361	black-plated screw-pill-iron plate	M4*20	12
13	MG00338	black-plated screw-T head $\phi 8$	M4*30	8
14	HB00968	PCB	XOVER-PCB 12S/15S	1
15	MG00020	black-plated screw-self tapping	M3*8	2
16	ME00015	color nut	3MM	8
17	MF00037	spring washer	$\phi 3*\phi 5*1T$	8
18	MF00023	color washer	$\phi 3*\phi 10*1T$	4
19	CN00061	crossover inductor	4.2mH($\phi 1.2$ mm E type)	1
20	MG00351	black-plated screw-pill-iron plate	M4*16	10
21	ME00093	iron pillar	hexagon 6.35*M3*28	2
22	MJ01207	fixed board	ELVIS15S ALTO	1
23	HC00218	speakon	SKCB201-4P connector female	2
24	MG00042	black-plated screw	M3*10	4
25	MG00364	black-plated screw	M3*12	4

7.BOM

ELVIS12M

No.	Part No.	Description	Specification	Remark
1	NC00144	cabinet	ELVIS 12M 12inch	
2	NI02375	handle cover	ELVIS 10;12;15 432C	
3	NI02376	handle	85.6*207*7 432C	
4	MJ01146	pillor	2t*201*79.6mm ELVIS	
5	MJ01166	iron board	2t*201*79.6mm ELVIS10	
6	MJ01154	single light board	2.0t*1850*950mm 27.6kg	
7	NC00307	rear board	ELVIS 12M 394.5*360.3*18t down_V1.0	
8	NC00236	Shaving board	2440*1220*18t_V1.0	
9	NC00308	rear board	ELVIS 12M 394.5*360.3*18t up_V1.0	
10	NC00236	Shaving board	2440*1220*18t_V1.0	
11	NC00309	side cover board	ELVIS 12M 290.5*585*18t right_V1.0	
12	NC00236	Shaving board	2440*1220*18t_V1.0	
13	NC00310	side cover board	ELVIS 12M 290.5*585*18t left_V1.0	
14	NC00236	Shaving board	2440*1220*18t_V1.0	
15	NC00311	rear board	ELVIS 12M 336*394.5*18t_V1.0	
16	NC00236	Shaving board	2440*1220*18t_V1.0	
17	NC00312	front board	ELVIS 12M 368.5*585*18t_V1.0	
18	NC00236	Shaving board	2440*1220*18t_V1.0	
19	NC00313	front faceplate	ELVIS 12M 155.9*394.5*18t_V1.0	
20	NC00236	Shaving board	2440*1220*18t_V1.0	
21	ND00417	Carpet cloth	2.5t*2M*0.89M YB-153_V1.0	
22	ND00415	Carpet cloth	2m*50m*2.5t*310g/ YB-153_V1.0	
23	ME00085	nut	M4	
24	ME00082	nut	M5	
25	ND00239	fillter sponge	4t*100*100mm	
26	NI02426	foot cushion	φ37*15.5mm	
27	MG00360	screw-RS	M4*25mm	
28	MG00338	screw-RS-T	M4*30mm	
29	MG00536	screw-RS	M4*20_V1.0	
30	ND00254	absorb sound sponge	30*500*350mm	
31	ND00453	Carpet cloth	30m*1m*30t_V1.0	
32	ND00255	absorb sound sponge	30*700*350mm	
33	ND00453	Carpet cloth	30m*1m*30t_V1.0	
34	ND00256	absorb sound sponge	30*350*350mm	
35	ND00453	Carpet cloth	30m*1m*30t_V1.0	
36	MD00425	grille	ELVIS 12M ALTO_V1.0	
37	MD00456	grille	ELVIS 12M_V1.1	
38	MD00457	grille	ELVIS 12M ALTO_V1.5	
39	MD00428	grille	ELVIS 12M 1.2t*570*382_V1.0	
40	MG00349	screw-RS-T	M3*16	
41	HK03075	woofer	12" 110W 6ΩELVIS 12;M(Z00773_LP318.50)	
42	NH00242	cone	B0710B_CN 318.50T3 Z5 45HZ	
43	NH00243	gasket	C0810A_GR 318/6+2	
44	ND00215	spider	D0777A_CT 50-150/3 C5	

No.	Part No.	Description	Specification	Remark
45	NH00241	dust mesh cap	E0533A_CP 98/C	
46	HK03050	magnet circuit-RS	F0741B_CM 50/1100.8 F18 V	
47	MH01568	washer	I0710A_PS 50/1100.8V_V1.2	
48	MH01566	magnet	G0425A D134*57*19	
49	MH01567	T type middle pillar	H0722A_PN 50/1100.8 D18	
50	MI01517	bracket	L0710B_CR 318/VN	
51	HC00426	terminal	M0021B_PT2.1	
52	HC00496	connect terminal	0.8*13*16.3mm	
53	HC00495	connect terminal	0.8*13*16.3mm	
54	NI02583	terminal block	3.5*24.5*3t	
55	MH01110	rivet	M0500A_OU-30	
56	HA02493	strand	TA4X4YKA42W*110mm	
57	HA02079	strand	TA4X4YKA42W*1M	
58	ND00227	sponge	S0721B_NYLON NET D35	
59	NE16130	lable	HK03075_V1.0	
60	NI00014	membrane	0.035*1M	
61	NH00012	bond paper	0.04*1M	
62	HG00202	voice coil	BSV50.5*36*5.25Ω	
63	MG00350	screw-RS-T	M5*30	
64	HG00081	speaker	PA-D597 P-AUDIO 8Ω	
65	MG00351	screw-RS	M4*16	
66	NI02242	horn	ELVIS 10;12;15 432C	
67	NI02374	fixed board	70*135*10 432C	
68	MG00352	screw-RS	M4*25	
69	ND00231	sponge	15*50*50mm	
70	HA02319	signle terminal wiring	600mm UL1015 18AWG brown/black	
71	HA02320	signle terminal wiring	800mm UL1015 18AWG	
72	NA00192	bag	0.05t*1200*800mm	
73	NF01105	instructions	ELVIS ALTO_V1.4	
74	NH00149	paper	889*640mm	
75	NF00061	assurance card	ALTO	
76	NE11462	label	ELVIS 12M	
77	NH00012	bond paper	0.04*1M	
78	NI00014	membrane	0.035*1M	
79	NB02451	box	ELVIS 12M ALTO_V1.2	
80	NE11345	label	ALTO PG	
81	NH00334	cone paper	0.040*1m	
82	HK04011	fixed board	ELVIS 12M ALTO	
83	MJ01210	fixed board	ELVIS 12M ALTO	
84	MJ01163	fixed board	ELVIS 10	
85	MJ01162	fixed board	ELVIS 10	
86	MJ00088	single light board	1.5*2135*1220 30.67kg	
87	ME00105	iron pillar	M3*7.2*0.5PH_V1.1	
88	MG00060	screw	M3*6	

No.	Part No.	Description	Specification	Remark
89	HC00218	speakon	SKCB201-4P connector female	
90	MG00042	black-plated screw	M3*10	
91	ME00015	color nut	3m/m	
92	HA03757	wire	100mm UL1015 18AWG red/black	
93	HB00858	PCB	ELVIS-IN_VER050930	
94	HK05003	PC board	P-ELVIS-NEW XOVER (ELVIS 12)	
95	HB01386	PCB	PS 2-XOVER(1*2)_VER041203	
96	CN00056	crossover inductance	1.55mH(1.0mm ϕ 1.50~1.60Mh)	L1
97	CN00049	crossover inductance	0.35mH(0.8mm ϕ 0.34-0.36mH)	L2
98	CF00089	metal-film capacitor MEF	10uF/250V 5%	C1
99	CF00090	metal-film capacitor MEF	3.3uF/250V 5%	C2
100	HA02087	jumper	23mm	C4
101	HA02249	wire	ϕ 0.6_Sn-plate	
102	RA00993	chassis bracket 20W	3.3 Ω SQY type	R1
103	RA00827	chassis bracket 20W	1.5 Ω SQZ	R2
104	RA00988	cement resistor 20W	10 Ω SQY type	R3
105	RA00839	chassis bracket 20W	39 Ω SQZ	R4
106	HH00036	lamp	SK3/CWT 12.8V 2.1A	DS1,DS2
107	HA01919	jumper	5mm	PTC1
108	HA02249	wire	ϕ 0.6_Sn-plate	
109	RG00012	over current protector	0.5A 60V MF-R050	PTC2
110	HC00324	connect terminal	6.5m/m (PC250)	
111	NI02590	cable tie	YJ-203V0 UL94V-0	
112	AC00179	tin without lead-RS	M705E Sn 3Ag-0.5Cu	
113	AC00179	tin without lead-RS	M705E Sn 3Ag-0.5Cu	
114	NB02506	cushion	ELVIS 12M below	
115	NB02507	cushion	ELVIS 12M upper	
116	AD00012	twin adhesive	90*120mm_V1.0	
117	NA00279	clip-chain bag	0.04t*100*150mm_V1.0	
118	NE12830	label	ELVIS 12M ALTO_V1.1	
119	NE11169	label	HK 12 ALTO	
120	NH00012	bond paper	0.04*1M	
121	NI00014	membrane	0.035*1M	
122	NA00122	PE bag	0.04t*350*230mm	

ELVIS 12S

No.	Part No.	Description	Specification	Remark
1	NC00143	cabinet	ELVIS 12S 12inch	
2	NI02375	handle cover	ELVIS 10;12;15 432C	
3	NI02376	handle	85.6*207*7 432C	
4	MJ01146	pillor	2t*201*79.6mm ELVIS	
5	MJ01166	iron board	2t*201*79.6mm ELVIS10	
6	MJ01154	single light board	2.0t*1850*950mm 27.6kg	
7	NC00293	side cover board	ELVIS 12S 417.6*464*18t right_V1.0	
8	NC00236	Shaving board	2440*1220*18t_V1.0	
9	NC00294	side cover board	ELVIS 12S 417.6*464*18t left_V1.0	
10	NC00236	Shaving board	2440*1220*18t_V1.0	
11	NC00295	rear board	ELVIS 12S 397*451*18t_V1.0	
12	NC00236	Shaving board	2440*1220*18t_V1.0	
13	NC00296	front board	ELVIS 12S 371*464*18t_V1.0	
14	NC00236	Shaving board	2440*1220*18t_V1.0	
15	NC00297	rear board	ELVIS 12S 371*464*18t_V1.0	
16	NC00236	Shaving board	2440*1220*18t_V1.0	
17	NC00298	front faceplate	ELVIS 12S 397*451*18t_V1.0	
18	NC00236	Shaving board	2440*1220*18t_V1.0	
19	ND00443	Carpet cloth	2.5t*2M*0.78M YB-153_V1.0	
20	ND00415	Carpet cloth	2m*50m*2.5t*310g/ YB-153_V1.0	
21	ME00085	nut	M4	
22	ME00082	nut	M5	
23	ME00083	nut	M6	
24	MG00353	screw-RS	M6*30	
25	MH01704	handle-RS	ELVIS ϕ 110*96_V1.0	
26	MH00801	bracket	ϕ 110*96_V1.1	
27	NI02426	foot cushion	ϕ 37*15.5mm	
28	MG00360	screw-RS	M4*25mm	
29	MG00338	screw-RS-T	M4*30mm	
30	MG00536	screw-RS	M4*20_V1.0	
31	ND00230	absorb sound sponge	30*500*250mm	
32	ND00453	Carpet cloth	30m*1m*30t_V1.0	
33	MD00421	grille	ELVIS 12S ALTO_V1.0	
34	MD00453	grille	ELVIS 12S_V1.1	
35	MD00454	grille	ELVIS 12S ALTO_V1.2	
36	MD00424	grille	ELVIS 12S 1.2t*449*382.5_V1.0	
37	MG00349	screw-RS-T	M3*16	
38	HK03074	speaker	12" 110W 4 Ω ELVIS 12S(Z00780_LP318.50)	
39	HG00084	voice coil-RS	A0737A_BA 50-36-350/14*4-3,5	
40	NH00268	cone	B0714B_CN318.5T3Z2 43HZ	
41	NH00243	cushion	C0810A_GR 318/6+2	
42	ND00276	spider	D0778A_CT 50.150/3 C3	
43	NH00233	cover	E0649A_CP 108/C	
44	HK03049	magnet circuit	F0757B_CM 50/1100.8 SW F18 V	

No.	Part No.	Description	Specification	Remark
45	MH01567	T type middle pillar	H0722A_PN 50/1100.8 D18	
46	MH01645	washer	I0713A_PS 50/1100.8 SW V_V1.4	
47	MH01566	magnet	G0425A D134*57*19	
48	MI01517	bracket	L0710B_CR 318/VN	
49	HC00426	terminal	M0021B_PT2.1	
50	HC00496	connect terminal	0.8*13*16.3mm	
51	HC00495	connect terminal	0.8*13*16.3mm	
52	NI02583	terminal block	3.5*24.5*3t	
53	MH01110	rivet	M0500A_OU-30	
54	HA02493	strand	TA4X4YKA42W*110mm	
55	HA02079	strand	TA4X4YKA42W*1M	
56	ND00227	sponge	S0721B_NYLON NET D35	
57	NE16131	lable	HK03074_V1.0	
58	NI00014	membrane	0.035*1M	
59	NH00012	bond paper	0.04*1M	
60	MG00350	screw-RS-T	M5*30	
61	MG00351	screw-RS	M4*16	
62	NA00220	PE bag	0.05t*1050*900mm	
63	NF01105	instructions	ELVIS ALTO_V1.4	
64	NH00149	paper	889*640mm	
65	NF00061	assurance card	ALTO	
66	NE11463	label	ELVIS 12S	
67	NH00012	bond paper	0.04*1M	
68	NI00014	membrane	0.035*1M	
69	NE11345	label	ALTO PG	
70	NH00334	cone paper	0.040*1m	
71	NB02449	box	ELVIS 12S ALTO_V1.3	
72	HK04003	fixed board	ELVIS 12S ALTO	
73	MJ01206	fixed board	ELVIS 12S ALTO	
74	MJ01207	fixed board	ELVIS 12S	
75	MJ01208	fixed board	1.5t*220*120 ELVIS 12S	
76	MJ00088	single light board	1.5*2135*1220 30.67kg	
77	ME00093	iron pillar	M3*26.5*0.5PH	
78	MG00020	screw	M3*8	
79	HC00218	speakon	SKCB201-4P	S1,S2
80	MG00364	screw	M3*12mm	
81	ME00015	color nut	3m/m	
82	CN00061	crossover inductance	4.2mH(wirepathφ1.2mm E type)	
83	MF00037	washer	φ3.2*φ5.5*1t	
84	MF00023	washer	φ3*φ10*1t	
85	MG00042	screw	M3*10	
86	HK04300	PC board	P-ELVIS-XOVER(ELVIS 12S/15S)	
87	HB00968	PCB	XOVER-PCB 12S/15S_VER030608	
88	CB00176	electrolytic capacitor	47uF/100V NP φ13*27mm	C2,C3,C4

No.	Part No.	Description	Specification	Remark
90	HC00339	connect terminal	6.5m/m (PCF250)	S3,S4
91	AC00179	tin without lead-RS	M705E Sn 3Ag-0.5Cu	
92	MG00402	screw-RS-T	M5*18	
93	HA02520	single terminal wiring	750mm UL1015 18AWG	
94	NA00279	clip-chain bag	0.04t*100*150mm_V1.0	
95	AD00012	twin adhesive	90*120mm_V1.0	
96	NE12828	label	ELVIS 12S ALTO_V1.1	
97	NA00414	silk wadding-RS	ELVIS 12SA_V1.0	
98	NB03947	paper defend horn	ELVIS 12SA 528*48mm_V1.0	
99	NE11169	label	HK 12 ALTO	
100	NH00012	bond paper	0.04*1M	
101	NI00014	membrane	0.035*1M	
102	NA00122	PE bag	0.04t*350*230mm	

ELVIS 15S

No.	Part No.	Description	Specification	Remark
1	NC00145	cabinet	ELVIS 15S 15 inch	
2	NI02375	handle cover	ELVIS 10;12;15 432C	
3	NI02376	handle	85.6*207*7 432C	
4	MJ01146	pillor	2t*201*79.6mm ELVIS	
5	MJ01166	iron board	2t*201*79.6mm ELVIS10	
6	MJ01154	single light board	2.0t*1850*950mm 27.6kg	
7	NC00300	side cover board	ELVIS 15S 475.2*534*18t right_V1.0	
8	NC00236	Shaving board	2440*1220*18t_V1.0	
9	NC00301	side cover board	ELVIS 15S 475.2*534*18t left_V1.0	
10	NC00236	Shaving board	2440*1220*18t_V1.0	
11	NC00302	rear board	ELVIS 15S 452.5*520*18t_V1.0	
12	NC00236	Shaving board	2440*1220*18t_V1.0	
13	NC00303	front board	ELVIS 15S 426.5*534*18t_V1.0	
14	NC00236	Shaving board	2440*1220*18t_V1.0	
15	NC00304	rear board	ELVIS 15S 426.5*534*18t_V1.0	
16	NC00236	Shaving board	2440*1220*18t_V1.0	
17	NC00305	front faceplate	ELVIS 15S 452.5*520*18t_V1.0	
18	NC00236	Shaving board	2440*1220*18t_V1.0	
19	ND00444	Carpet cloth	2.5t*2M*0.98M YB-153 grey_V1.0	
20	ND00415	Carpet cloth	2m*50m*2.5t*310g/ YB-153_V1.0	
21	ME00085	nut	M4	
22	ME00082	nut	M5	
23	ME00083	nut	M6	
24	MG00353	screw-RS	M6*30	
25	MH01704	handle-RS	ELVIS ϕ 110*96_V1.0	
26	MH00801	bracket	ϕ 110*96_V1.1	
27	NI02426	foot cushion	ϕ 37*15.5mm	
28	MG00360	screw-RS	M4*25mm	
29	MG00338	screw-RS-T	M4*30mm	
30	MG00536	screw-RS	M4*20_V1.0	
31	ND00232	absorb sound sponge	40*500*250mm	
32	ND00454	Carpet cloth	25m*1m*40t white_V1.0	
33	MD00429	grille	ELVIS 15S ALTO_V1.0	
34	MD00450	grille	ELVIS 15S_V1.1	
35	MD00451	grille	ELVIS 15S ALTO_V1.5	
36	MD00432	grille	ELVIS 15S 1.2t*519*441_V1.0	
37	MG00349	screw-RS-T	M3*16	
38	HK03076	speaker	15" 150W 4 Ω ELVIS 15S(Z00822_LP385.65)	
39	NH00235	cone	B0822B_CN 385.65T3 Z2 40HZ	
40	NH00237	cushion	C0910A_GR 385/6+2	
41	ND00223	spider-RS	C0830A_CT 65-145/12 C3	
42	NH00233	dust mesh cap	E0649A_CP 108/C	
43	HK03052	magnet circuit	F0813B_CM 65/1450.8 SW F30 J	
44	MH01649	T type middle pillar	H0811A_PN 65/1450.10 D30	

No.	Part No.	Description	Specification	Remark
45	MH01646	washer	I0813A_PS 65/1450.8 SW J	
46	MH01647	magnet	G0450A_D154*73*19mm	
47	MI01613	bracket	L0810B_CR 385/J N_V1.1	
48	HC00426	terminal	M0021B_PT2.1	
49	HC00496	connect terminal	0.8*13*16.3mm	
50	HC00495	connect terminal	0.8*13*16.3mm	
51	NI02583	terminal block	3.5*24.5*3t	
52	MH01110	rivet	M0500A_OU-30	
53	HA02494	strand	TA4X4YKA42W*120mm	
54	HA02079	strand	TA4X4YKA42W*1M	
55	ND00228	sponge	S0720B_NYLON NET D45	
56	NE16123	lable	HK03076_V1.0	
57	NI00014	membrane	0.035*1M	
58	NH00012	bond paper	0.04*1M	
59	HG00085	voice coil-RS	A0832A_BA 65-40-375/13*4-3,5	
60	MG00350	screw-RS-T	M5*30	
61	MG00351	screw-RS	M4*16	
62	NF01105	instructions	ELVIS ALTO_V1.4	
63	NH00149	paper	889*640mm	
64	NF00061	assurance card	ALTO	
65	NE11464	label	ELVIS 15S	
66	NH00012	bond paper	0.04*1M	
67	NI00014	membrane	0.035*1M	
68	NE11345	label	ALTO PG	
69	NH00334	cone paper	0.040*1m	
70	NB02450	box	ELVIS 15S ALTO_V1.2	
71	HK04004	fixed board	ELVIS 15S ALTO	
72	MJ01209	fixed board	ELVIS 15S ALTO	
73	MJ01207	fixed board	ELVIS 12S	
74	MJ01208	fixed board	1.5t*220*120 ELVIS 12S	
75	MJ00088	single light board	1.5*2135*1220 30.67kg	
76	ME00093	iron pillar	M3*26.5*0.5PH	
77	MG00020	screw	M3*8	
78	HC00218	speaker socket	SKCB201-4P	S1,S2
79	MG00364	screw	M3*12mm	
80	ME00015	color nut	3m/m	
81	CN00061	crossover inductance	4.2mH(wirepathφ1.2mm E type)	
82	MF00037	washer	φ3.2*φ5.5*1t	
83	MF00023	washer	φ3*φ10*1t	
84	MG00042	screw	M3*10	
85	HK04300	PC board	P-ELVIS-XOVER(ELVIS 12S/15S)	
86	HB00968	PCB	XOVER-PCB 12S/15S _VER030608	
87	CB00176	electrolytic capacitor	47uF/100V NP φ13*27mm	C2,C3,C4
88	CF00090	metal-film capacitor MEF	3.3uF/250V 5%	C1

No.	Part No.	Description	Specification	Remark
89	HC00339	connect terminal	6.5m/m (PCF250)	S3,S4
90	AC00179	tin without lead-RS	M705E Sn 3Ag-0.5Cu	
91	MG00402	screw-RS-T	M5*18	
92	HA02520	single terminal wiring	750mm UL1015 18AWG	
93	NA00279	clip-chain bag	0.04t*100*150mm_V1.0	
94	AD00012	twin adhesive	90*120mm_V1.0	
95	NE12824	label	ELVIS 15S ALTO_V1.1	
96	NA00413	silk wadding-RS	ELVIS15SA_V1.0	
97	NB03946	paper defend horn	ELVIS 15SA 593*48mm_V1.0	
98	NA00221	pe bag	0.05t*1200*1050mm	
99	NE11168	label	HK 15 ALTO	
100	NH00012	bond paper	0.04*1M	
101	NI00014	membrane	0.035*1M	
102	NA00122	PE bag	0.04t*350*230mm	