

# **Service** *Manual*

**MODEL: MAC2.2/2.3 MKII**

# CONTENT

1. INTRODUCTION.....	1
2. TECHNICAL SPECIFICATIONS.....	2
3. BLOCK DIAGRAM & SCHEMATIC DIAGRAM.....	3
4. PCB LAYOUT.....	9
5. EXPLODED VIEW & PARTS LIST.....	15
6. BOM.....	17

# 1 INTRODUCTION

MAC2.2/2.3MK II is highly effective AMP with high power, providing balanced input , Barrier strip for SP output ,as well as STEREO/PARALLEL/BRIDGE/LIMIT/30HZ filter functions .

The users can choose the respective inner protection measures and power supply to avoid high temperature and short circuit.

2U body , big professional stereo power amplifier.

Wonderful tone quality and great volume level

Hard appearance and durable, it can be installed in cabinet or as a solo one.

The amplifier power :

MAC2.2MK II :

stereo output :350W\*2(4 RMS), 750W\*2(2 EIAJ)

bridge output: 710W(8 RMS), 1500 W\*2(4 EIAJ)

MAC2.3MK II :

stereo output :550W\*2(4 RMS), 750W\*2(2 EIAJ)

bridge output: 1150W (8 RMS), 1500 W\*2(4 EIAJ)

Many controls on the rear panel:

the clip limiter SW

the filter switch :30HZ

Stereo / Double-single /Parallel or Bridge operation modes.

separate balanced signal input .

Connect speaker cable to output terminal of rear panel

Signal,clip ,protection ,power LEDs on the panel

Each channel has separate DC, heat protection and over-load circuit , protecting the amplifier and speaker automatically.

## 2 TECHNICAL SPECIFICATIONS

POWER SPECIFICATIONS		MAC2.2	MAC2.3
Stereo Mode (Both channels driven) 20Hz—20KHz	2 Ohms(EIAJ)	750W ✂	1000W
	4 Ohms(RMS)	350W ✂	510W
	8 Ohms(RMS)	230W ✂	285W
Bridge Mono Mode 20Hz—20KHz	8 Ohms(RMS)	710W	1000W
	4 Ohms(EIAJ)	1500W	2200W
ELECTRICAL SPECIFICATIONS			
INPUT SENSITIVITY		1.15V(+3.4dBu)	
INPUT IMPEDANCE		10k Unbalanced	20k Balanced
FREQUENCY RESPONSE at 10dB below rated output power		25Hz—25KHz +0/-1 dB -3dB points:5 Hz—50KHz	
VOLTAGE GAIN		30dB	32dB
DISTORTION(SMPLE-1M)		< 0.03%	< 0.03%
S/N ration		100dB	100dB
GENERAL SPECIFICATIONS			
PROTECTIONS		Full short circuit,open circuit,thermal,ultrasonic,and RFprotection stable into reactive or mismatched loads,turnON/OFF,muting,triad crowbar	
CONTROLS		Front:AC switch,Input level control for each channel Rear:stereo/parallel/bridged selector,30Hz filter selector clip ON/OFF selector	
INDICATORS		SIGNAL:2 green LEDs CLIP:2 red LEDs POWER:1 blue LED PROTECTION:1 red LED	
CONNECTORS		INPUT:Active balanced XLR and 1/4"(6.3mm)TRS OUTPUT:touch-proof binding posts and speakon jacks	
POWER SUPPLY		Available for 110-120V or 220-240V AC,50/60Hz	
DIMENSIONS		483(W)*460(D)*88.8(H)mm	
WEIGHT		13.6kg	15.6kg

MAC2.2/2.3MKII SYSTEM BLOCK DIAGRAM

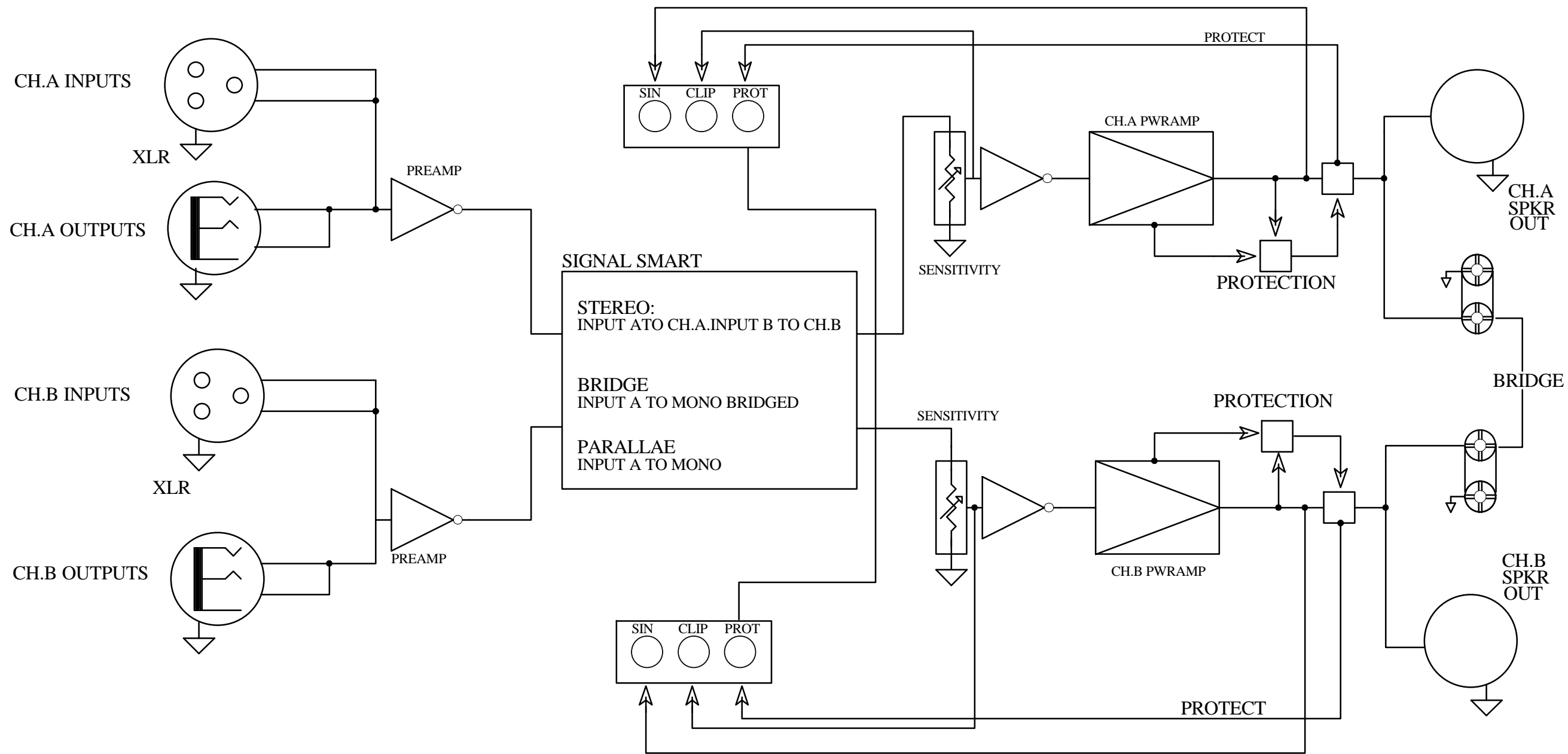

Titel			MAC2.2/2.3MKII SYSTEM BLOCK DIAGRAM		
Size	Model No:	Revision			
A3	MAC2.2/2.3MKII	VER071102			
Date:	02-Nov-2007	Sheet	1 of 1		
File:	AC2.2/2.3MKII方框圖	Drawn By:	JJZ		

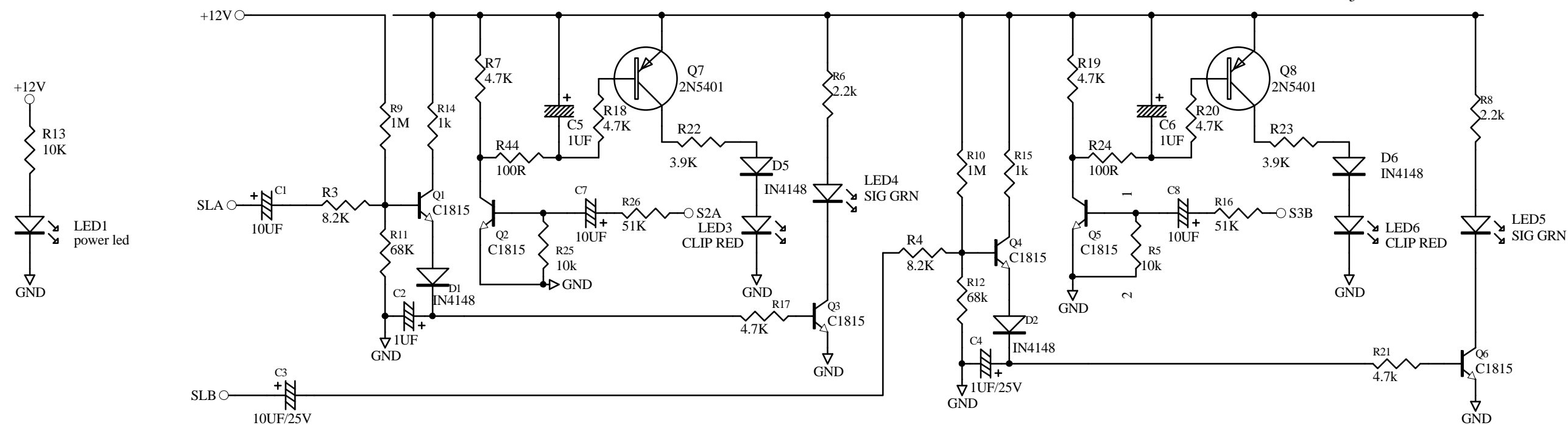
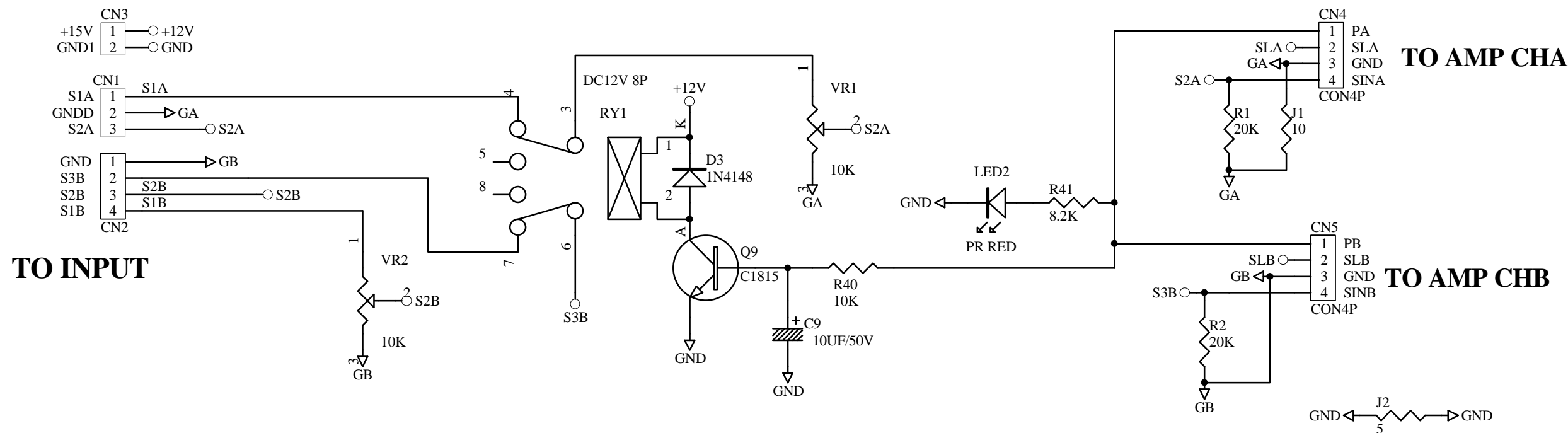

Titel: MAC2.3MKII VRL		
Size: A4	Model No: MAC2.2/2.3MKII	Revision: VER071102
Date: 02-Nov-2007	Sheet: 1 of 1	
File: MAC2.3MKII VRL.SCH	Drawn By: JJZ	

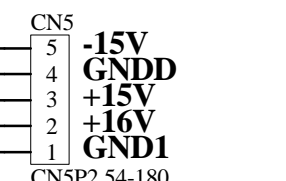
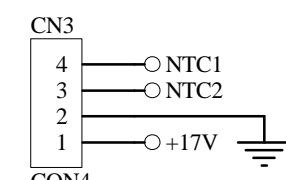
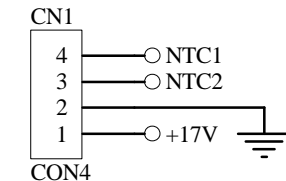
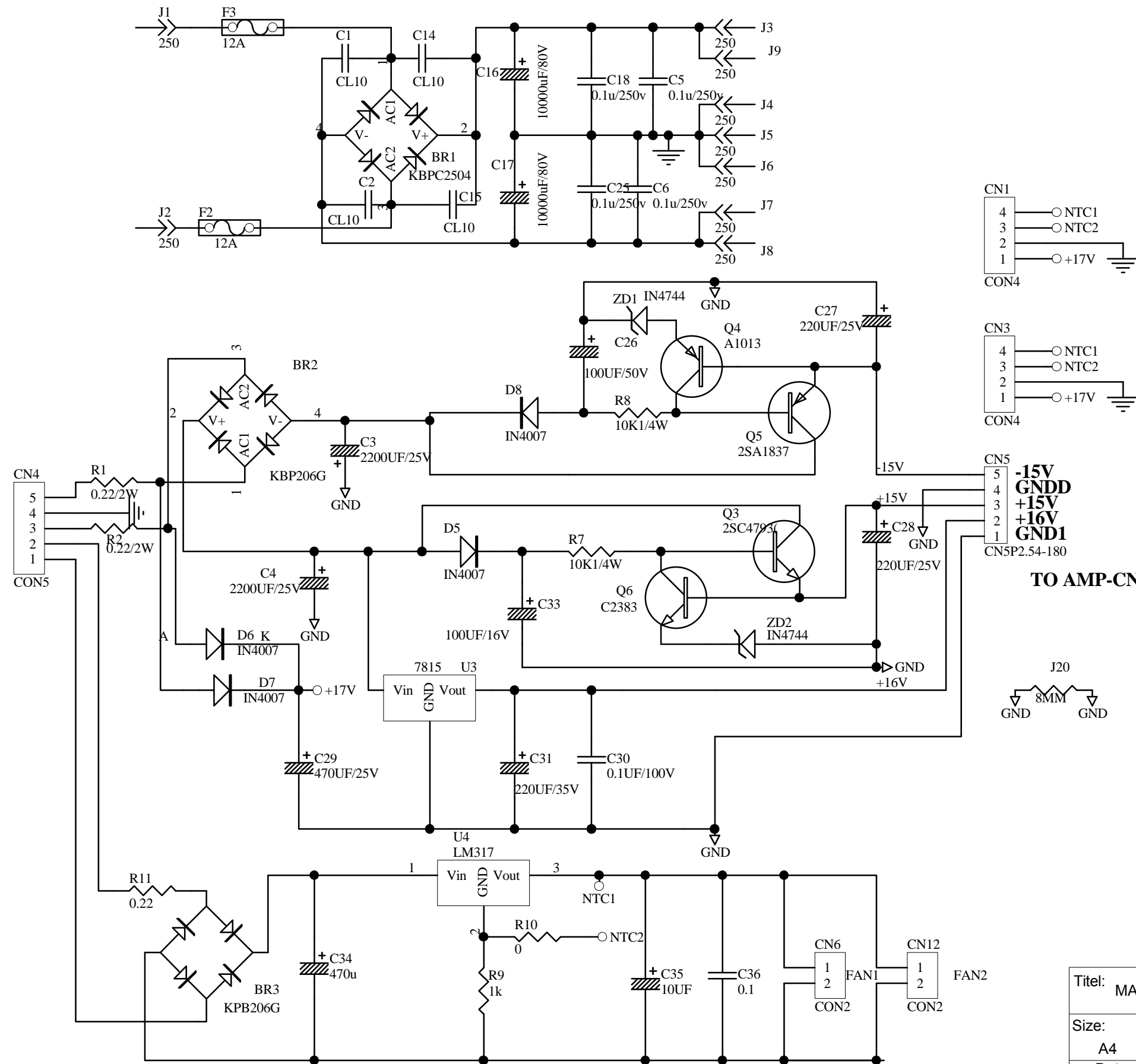

TO AMP-CN7

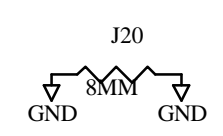

Titel: MAC2.3MKII POWER		
Size: A4	Model No: MAC2.2/2.3MKII	Revision: VER071102
Date: 02-Nov-2007	Sheet: 1 of 1	
File: MAC2.3MKII POWER.SCH	Drawn By: JJZ	

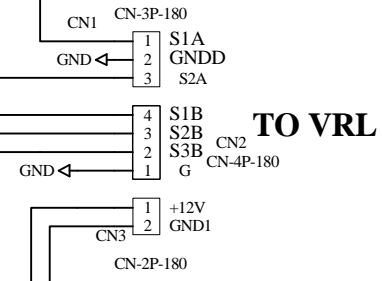
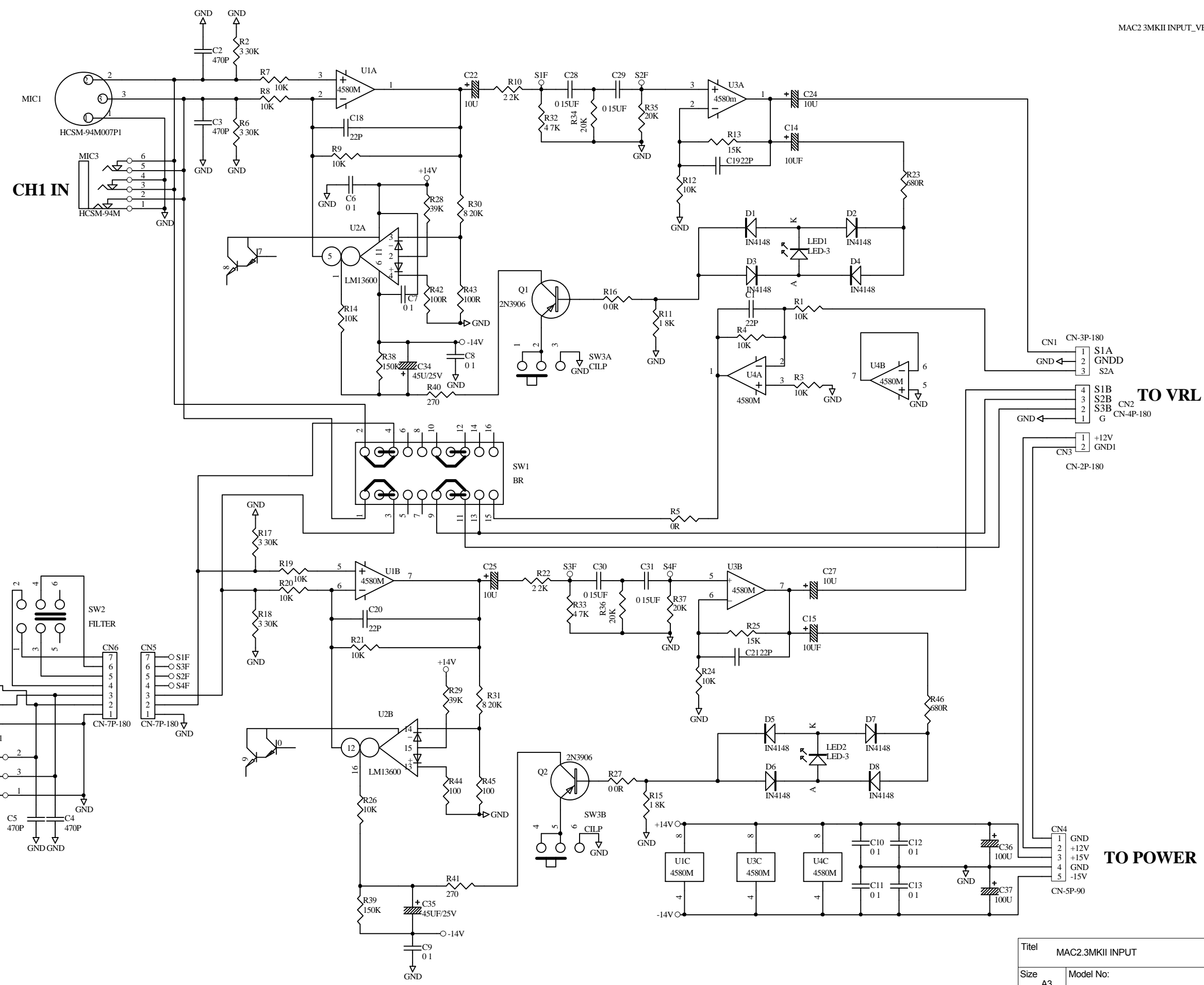

Titel		
MAC2.3MKII INPUT		
Size	Model No:	Revision
A3	MAC2.2/2.3MKII	VER071102
Date:	02-Nov-2007	Sheet 1 of 1
File:	MAC2.3MKII INPUT.SCH	Drawn By: JJZ



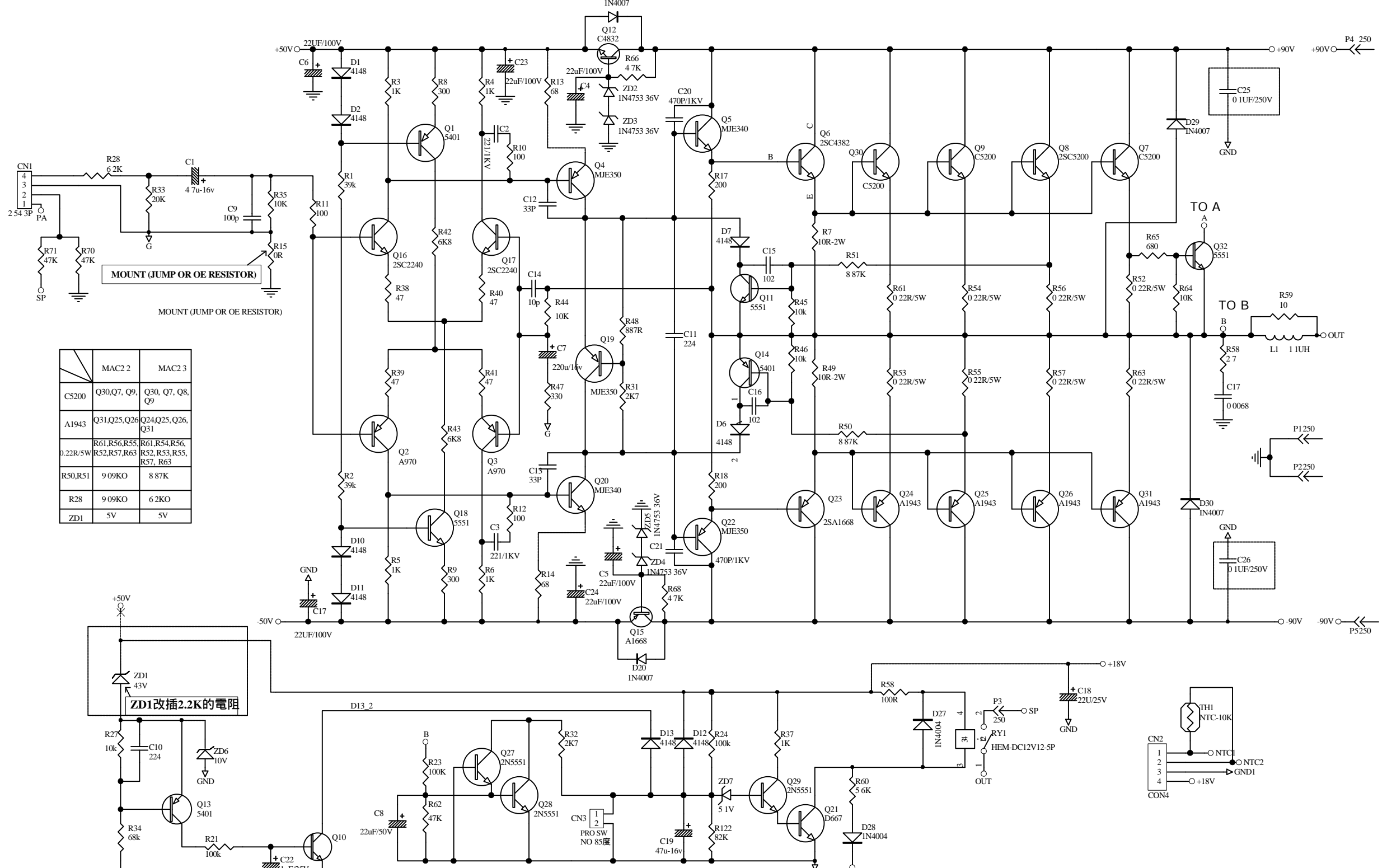

	MAC2 2	MAC2 3
CS200	Q30,Q7, Q9,	Q30, Q7, Q8, Q9
A1943	Q31,Q25,Q26	Q24,Q25, Q26, Q31
	R61,R56,R55, R52,R57,R63	R61,R54,R56, R52, R53, R55, R57, R63
R50,R51	9 09KO	8 87K
R28	9 09KO	6 2KO
ZD1	5V	5V

ZD1改插2.2K的电阻

Titel: MAC2 3MKII AMP		
Size: A3	Model No: MAC2 2/2.3MKII	Revision: VER081022
Date: 22-Octo-2008	Sheet: 1 of 1	
File: MAC2 3MKII AMP.SCH	Drawn By: JJZ	

Titel		CHB-PU-2	
Size	A4	Model No:	MAC2.4 MKII
Date:	19-Nov-2007	Revision	VER021004
File:	CHB_INPUT.SCH	Sheet	1 of 1
		Drawn By:	DECHUN QIN

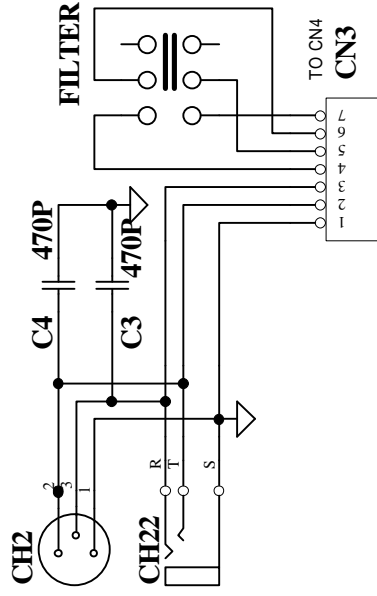

# MAC2.2/2.3MKII配線圖

MAC2.2/2.3MKII配線圖(1/1)

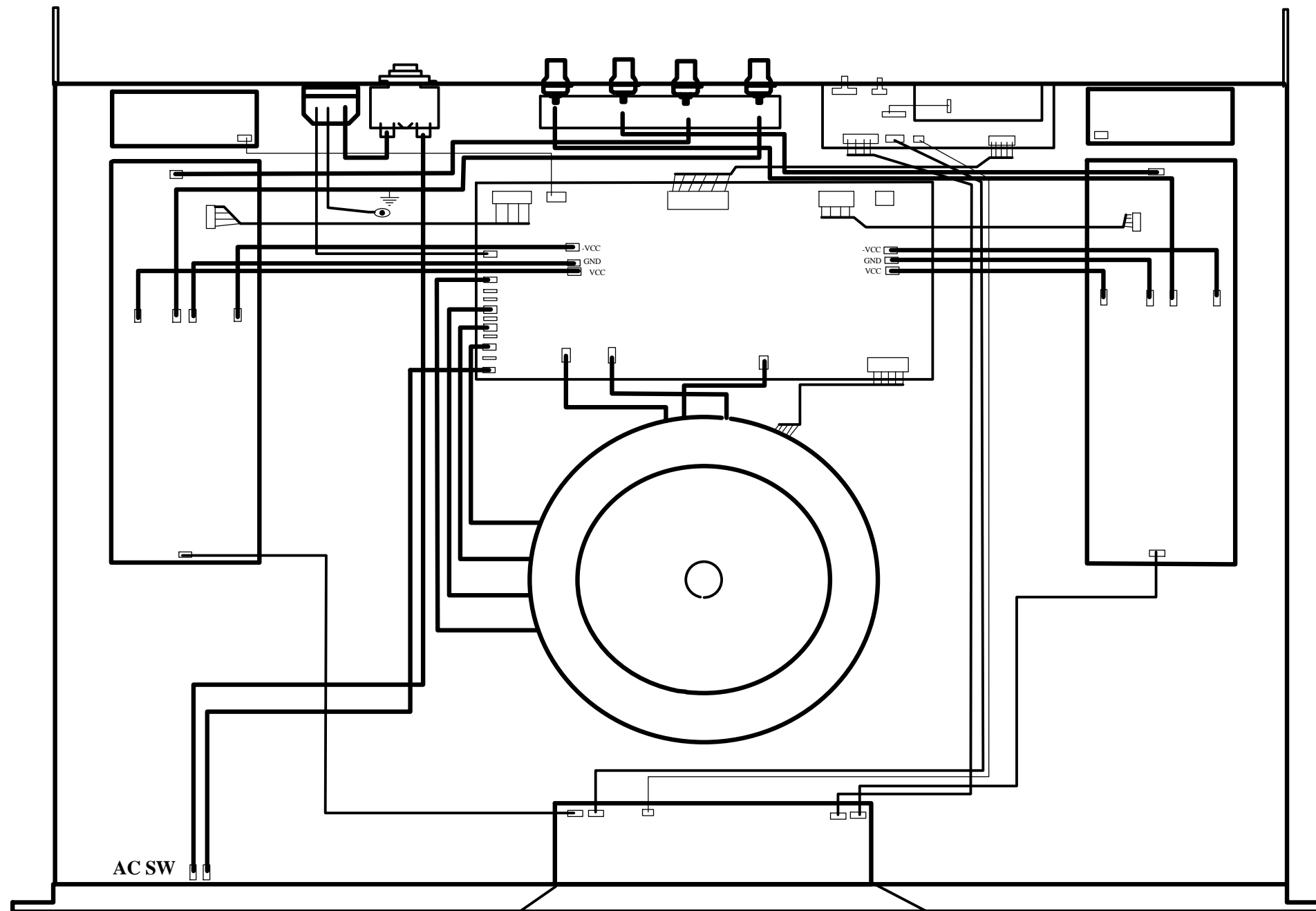

Title: MAC2.2/2.3MKII配線圖		
Size: A4	Model No: MAC2.2/2.3MKII	Revision: VER071109
Date: 09-Nov-2007	Sheet: 1 of 1	
File: MAC2.2/2.3MKII配線圖	Drawn By: JJZ	

CHB-PU-2-TOPOVER LAYER

PCB SIZE=(X)63\*(Y)36m/m

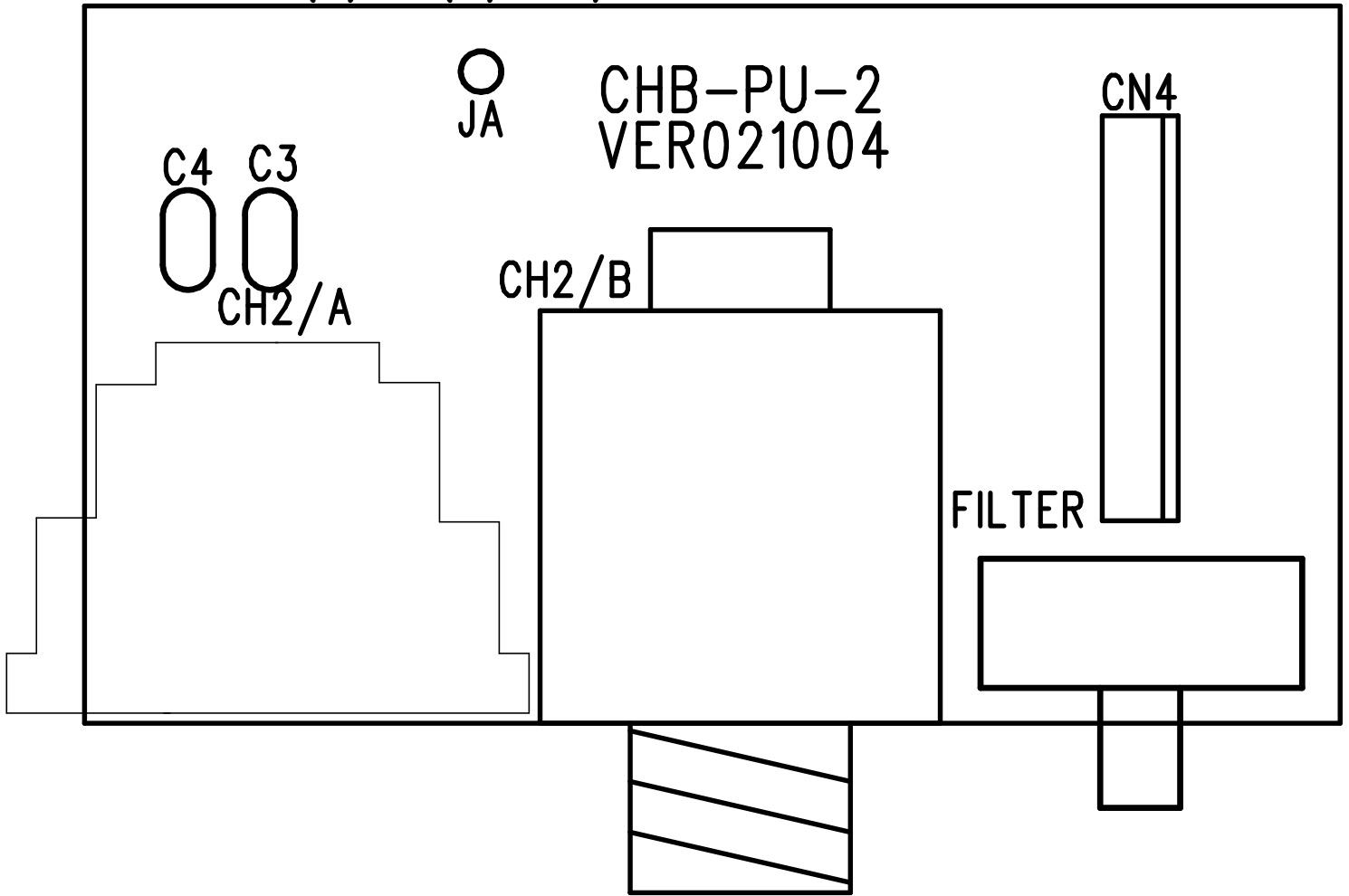

CHB-PU-2-BOTTOM LAYER

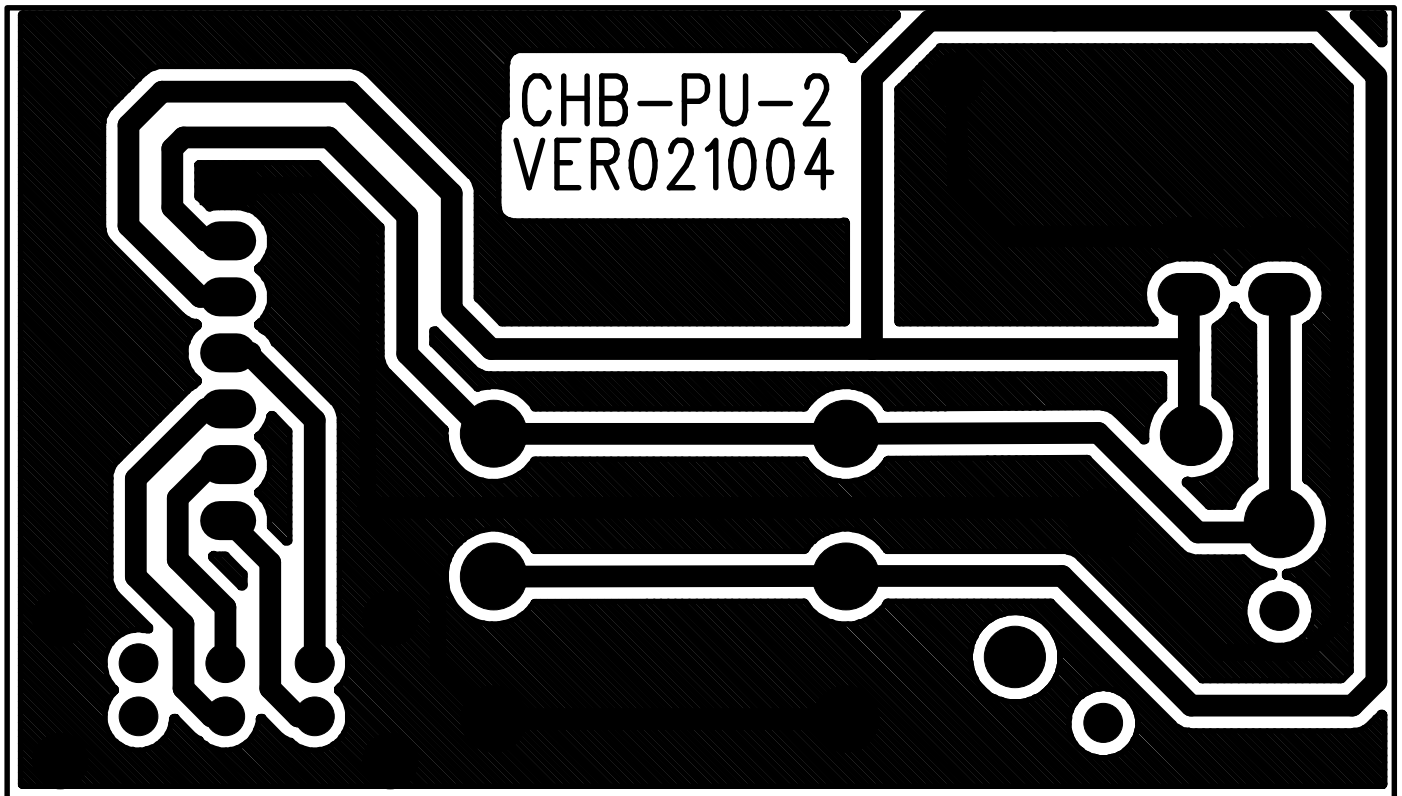

PG2200 OUT TOPOVER LAYER

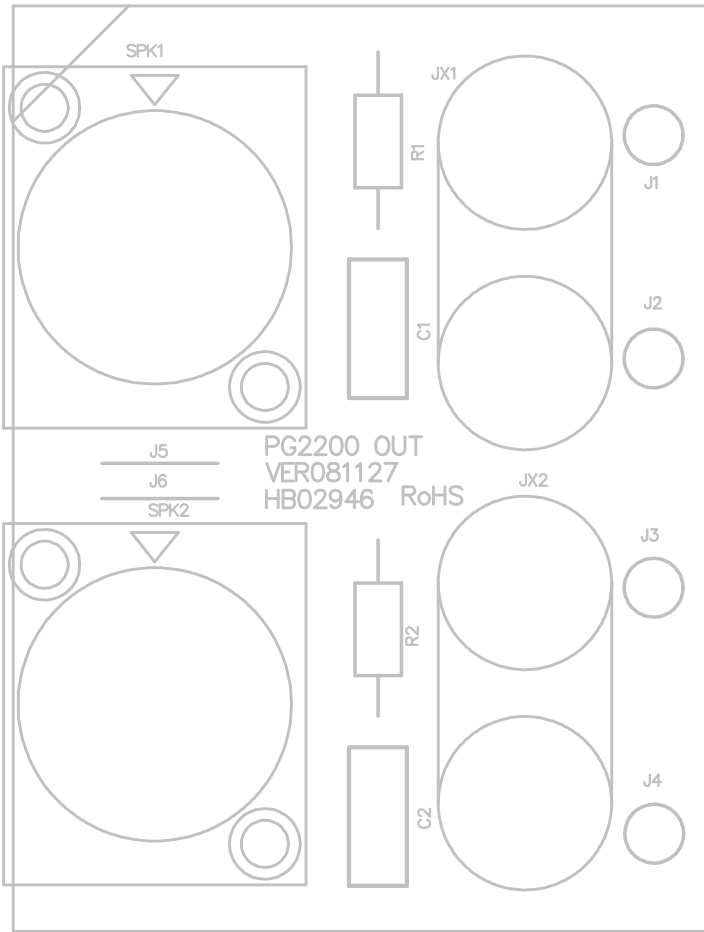

PG2200 OUT BOTTOM+BOTTOMOVER LAYER

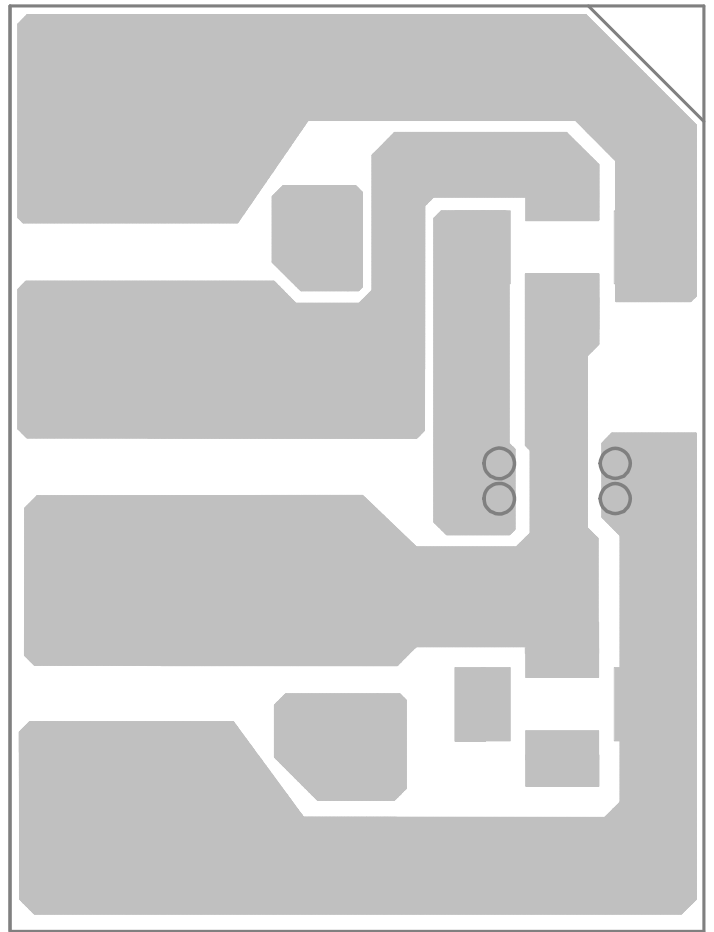

MAC2.3MKII-POWER BOTTOM+BOTTOMOVER LAYER

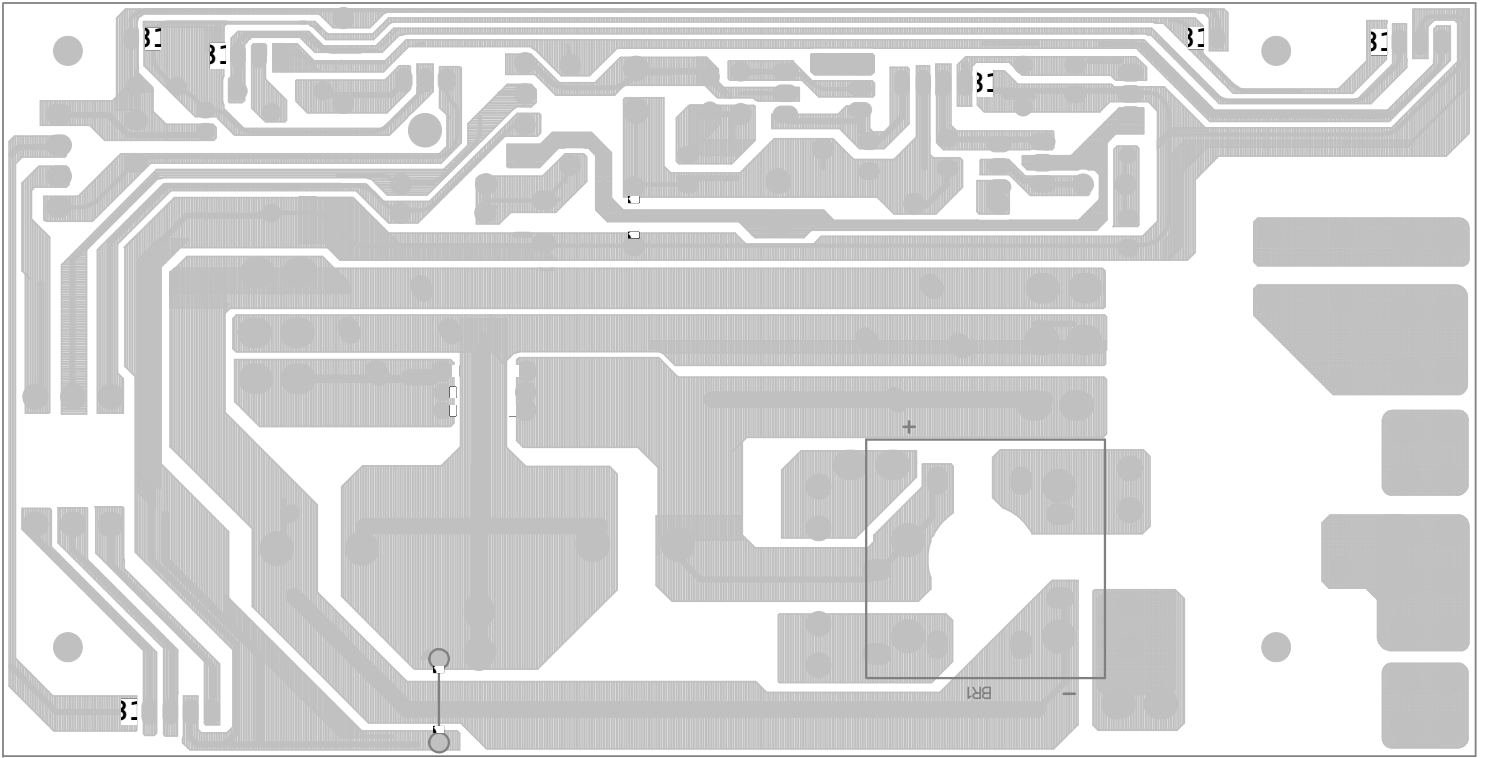

MAC2.3MKII-POWER TOPOVERLAYER

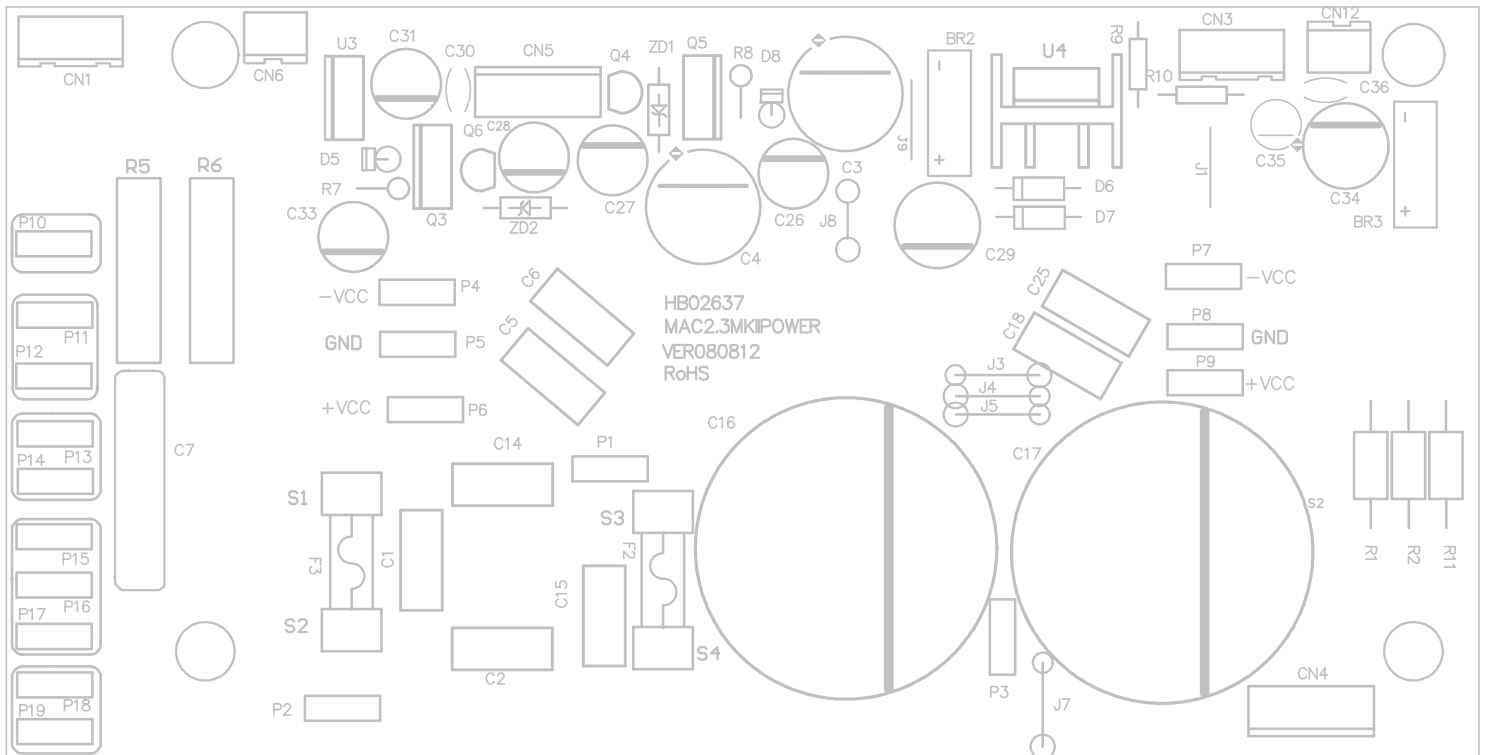

MAC2.3MKII-AMP BOTTOM+BOTTOMOVER LAYER

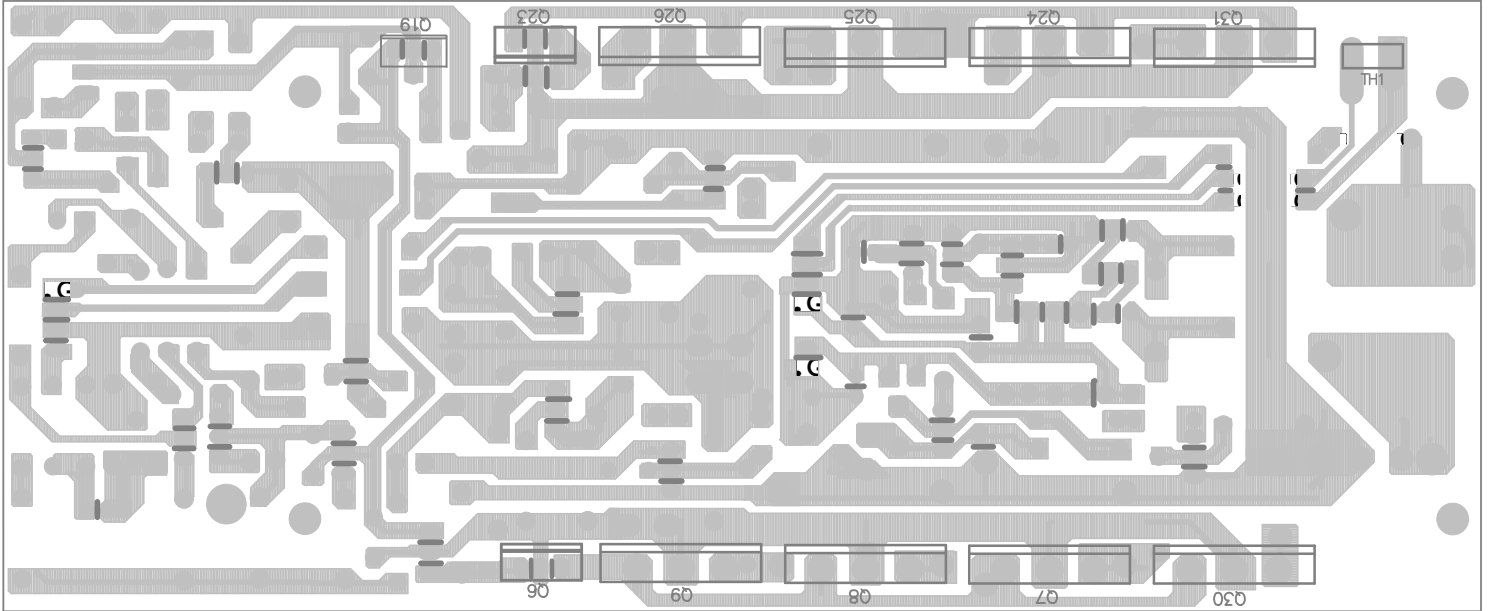

MAC2.3MKII-AMP TOPOVER LAYER

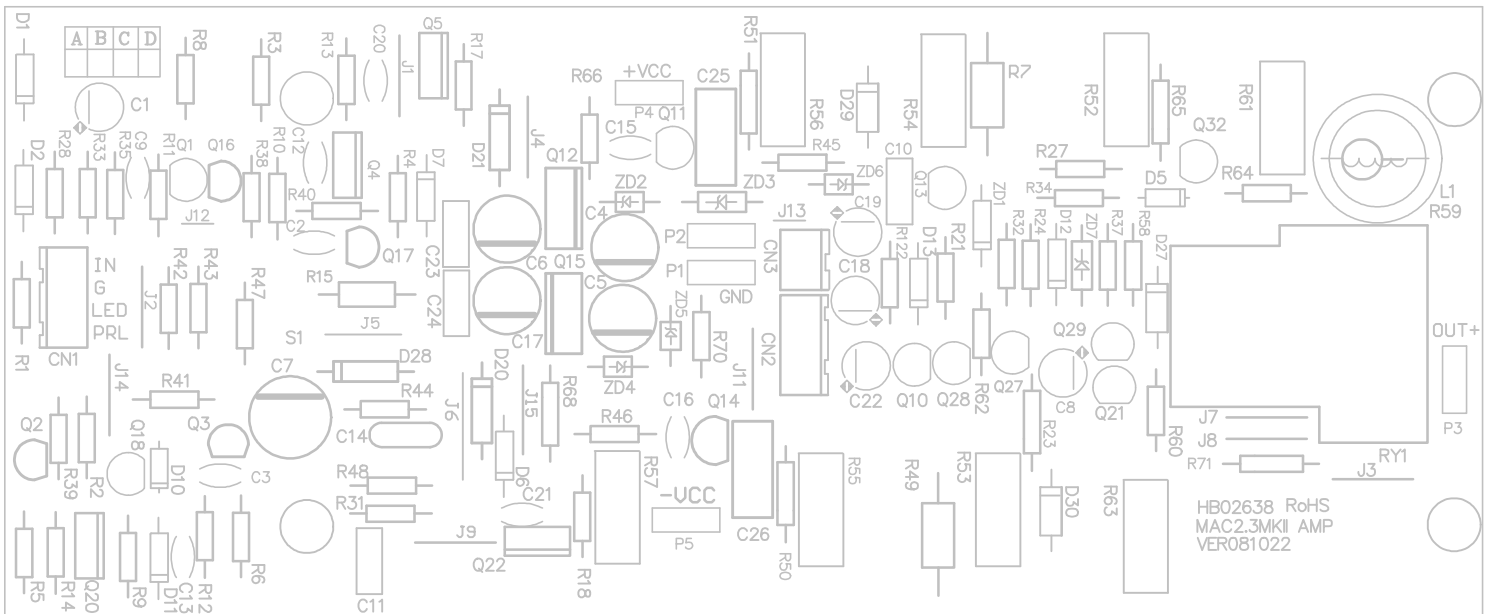

MAC2.3MKII-INPUT BOTTOM+BOTTOMOVER LAYER

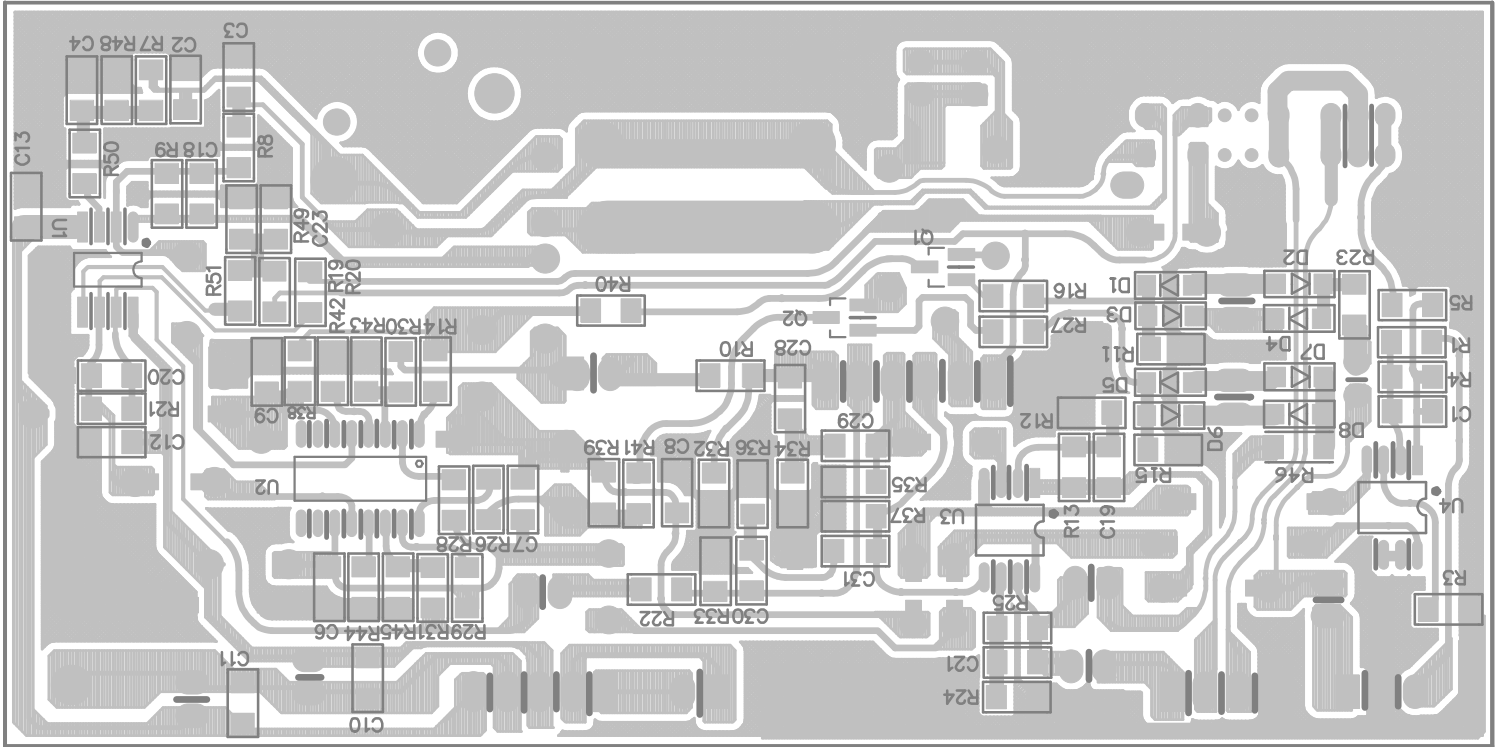

MAC2.3MKII-INPUT TOPOVER LAYER

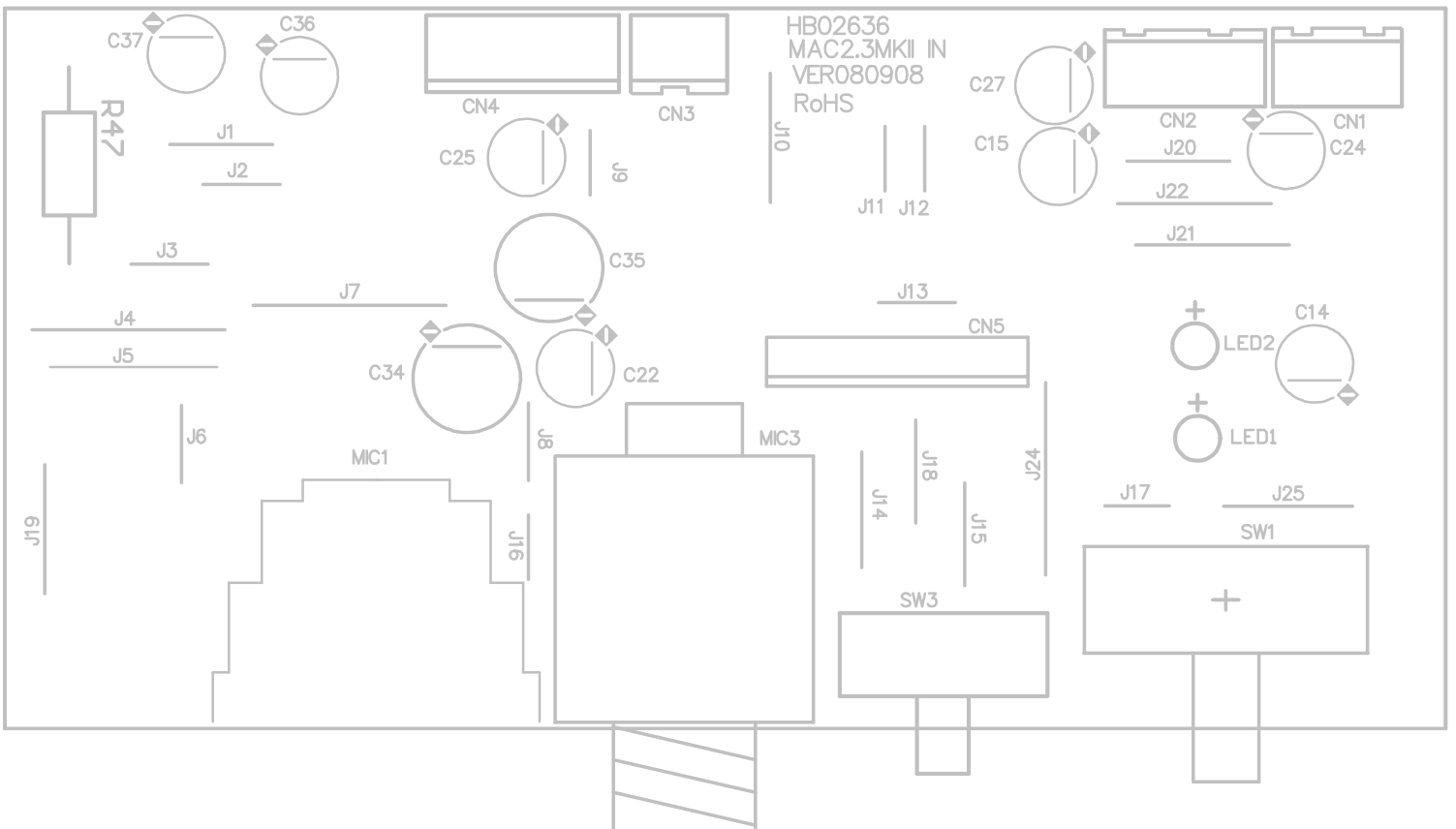



MAC2.3MKII-VRL BOTTOM+BOTTOMOVER LAYER

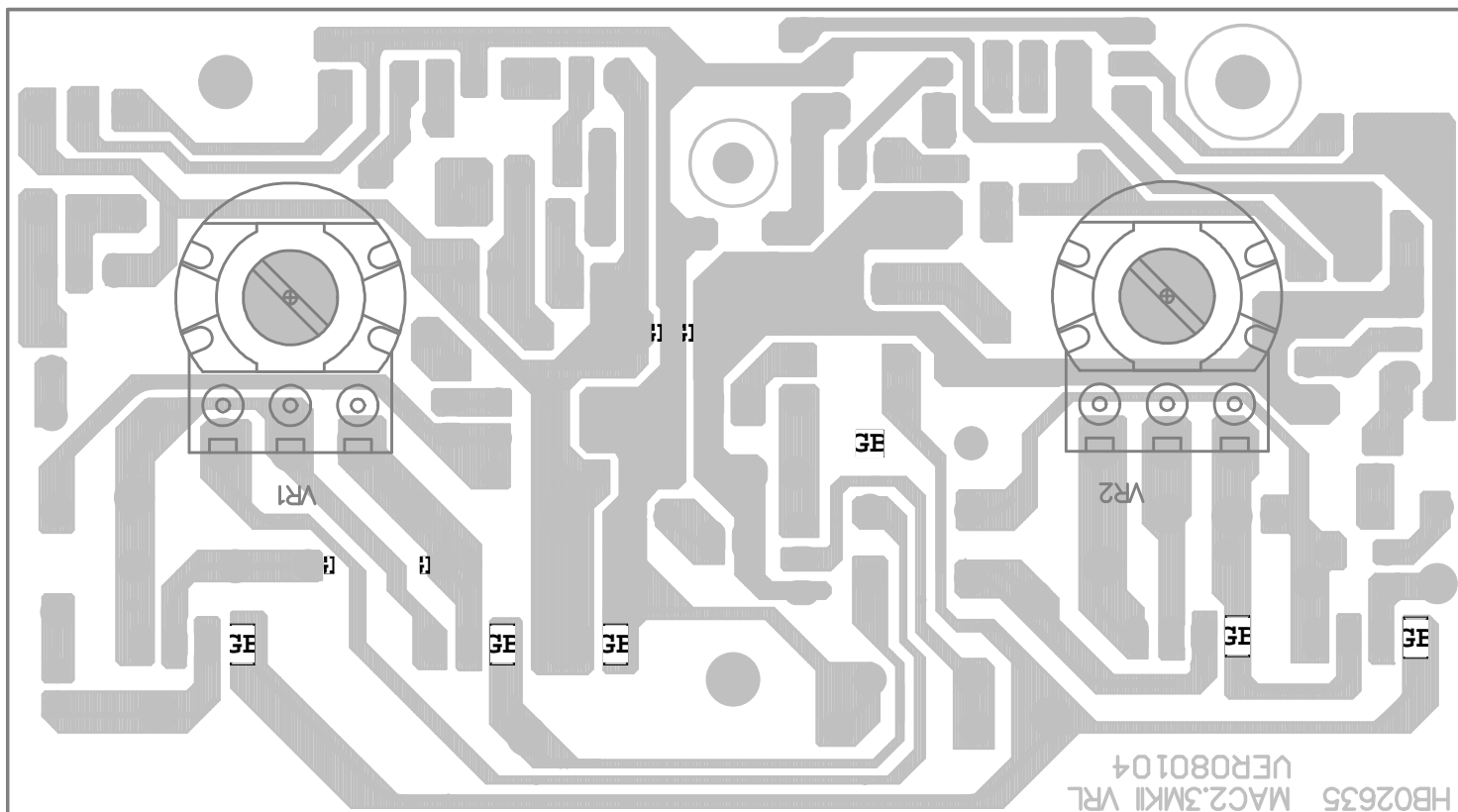

MAC2.3MKII-VRL TOPOVER LAYER

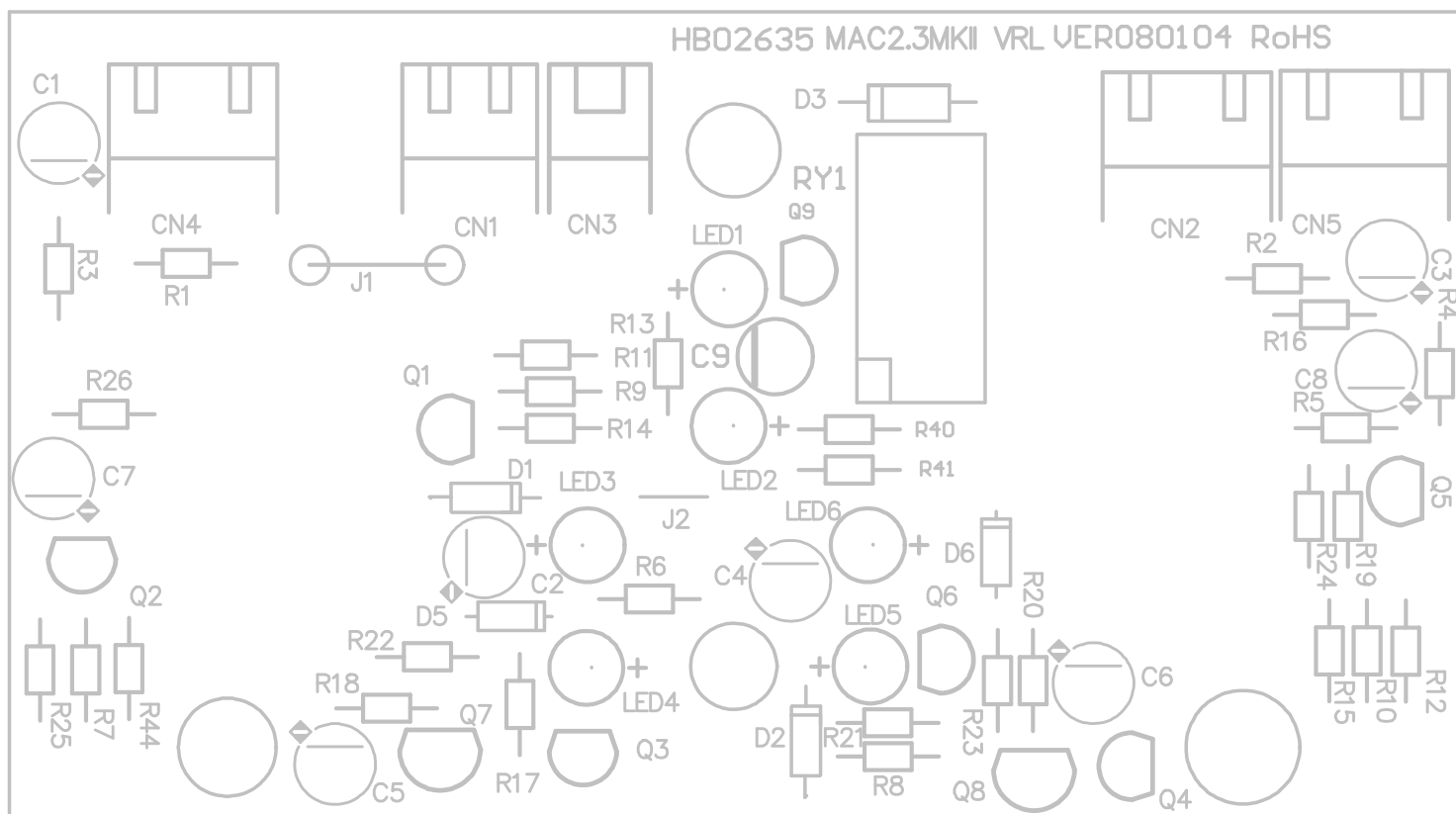

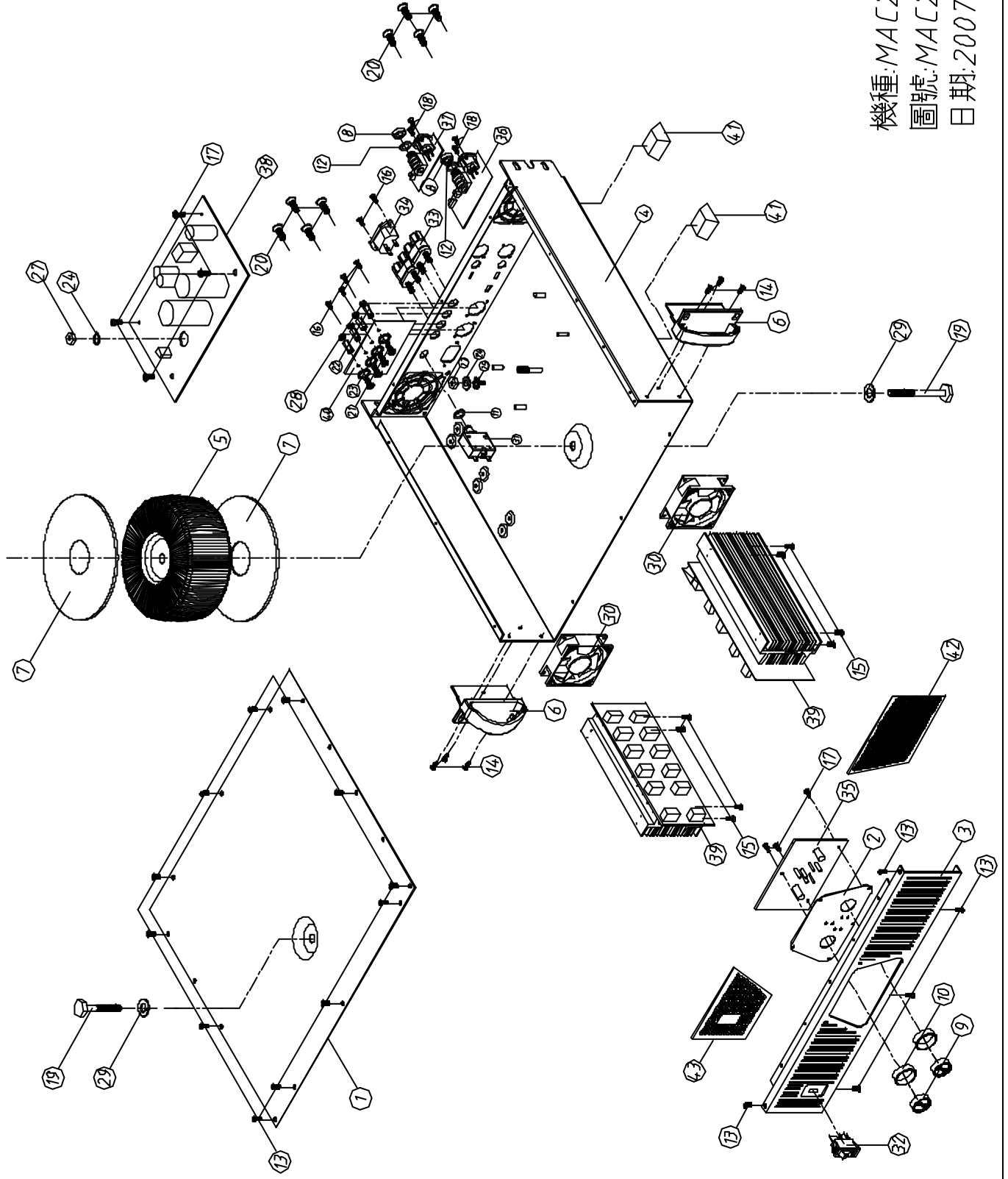

機種:MAC2.2 MKII  
圖號:MAC2.2 MKII-00  
日期:20071114

No.	Part No.	Description	Specification	PCS
1	MB05850	BOTTOM REAR PANEL	MAC 2.3MKII_V1.0	1
2	MI04659	HEAT SINK	150*79*59.5 V1.0	2
3	TD00687	TOROIDAL TRANSFORMER	PT MAC2.3MKII 220/230/240V	1
4	TD00685	TOROIDAL TRANSFORMER	PT MAC2.2MKII 220/230/240V	1
5	HB02635	PC BOARD	MAC 2.3MKII VRL VER071109	1
6	HB02636	PC BOARD	MAC 2.3MKII_INPUT_VER071102	1
7	HB02637	PC BOARD	MAC 2.3MKII POWER VER071102	1
8	HB02638	PC BOARD	MAC 2.3MKII AMP VER071109	2
9	HK09298	K-PC BOARD	MAC 2.3MKII VRL DIP	1
10	HK09309	K-PC BOARD	MAC 2.3MKII-INPUT-DIP	1
11	HK09342	K-PC BOARD	P-MAC2.3MKII OUT	1
12	HK09308	K-PC BOARD	MAC 2.3MKII POWER-DIP	1
13	HK09301	K-PC BOARD	MAC 2.3MKII AMP-DIP	2
14	HK09356	K-PC BOARD	MAC 2.2MKII POWER-DIP	1
15	HK09300	K-PC BOARD	MAC 2.2MKII AMP-DIP	2

Rank	Part No.	Description	Specification	QTY	Remark
PI02092		STEREO AMPLIFIER	MAC 2.3 MK ALTO 230V	1	
0001	MA05421	panel	MAC 2.3 ALTO_V1.1	1	
0002	MA07429	panel-RS	MAC2.4 MK _V1.0	1	
0003	TD00687	transformer-RS	PT-MAC2.3MK 220/230/240V	1	
0004	MI02436	handle	MAC2.2 V1.0	2	
0005	NI00437	rubber coil	20* 120*2tB	2	
0006	NI00252	sleeve	4*20mm	3	1.AC connector
0007	NI00002	plastic nut-RS	7/16**G20/15*4.8	2	
0008	NI02650	knob	18*18mm V1.1	2	
0009	NI02651	knob fixsheath	10* 22.5	2	
0010	ND00410	dust-proof shade	167.3*85.6*5.0t_V1.1	1	
0011	ND00409	dust-proof shade	167.3*85.6*5.0t_V1.1	1	
0012	NI00389	plastic washer	12* 16*0.5	2	1.manual return SW
0013	MG00025	screw-RS	M3*6	20	upper cover*13, panel*7
0014	MG00289	screw	M4*12	6	handle*6
0015	MG00042	screw	M3*10	4	speak-on connector*4
0016	MG00162	screw	M3*8	7	POW*4,VRL*3
0017	MG00327	screw	M3*10*0.5PH	4	MIC connector*4
0018	MG00014	hexagon screw	M10*25*1.5PH	2	PT
0019	MG00607	screw	M5*10	8	1.fan*8
0020	MG00535	screw	M5*6 V1.0	4	OUT*4
0021	MG00534	copper pillar	M5*16 V1.0	4	OUT*4
0022	MF00039	washer	5* 8*1t	4	OUT*4
0023	MF00038	washer-RS	4* 7*1t	1	1.ground*1
0024	MF00048	washer-RS	4* 8*0.5t	1	1.ground
0025	MF00037	washer	3.2* 5.5*1t	4	panel*4
0026	ME00016	color nut	4m/m	1	1.ground*1
0027	ME00015	color nut	3m/m	4	panel*4
0028	MF00044	washer	10* 16*2t	2	
0029	HE00005	fan-RS	DC12V/3000RPM80*80*2 5mm 380mm 2.5 2P	2	
0030	HI00143	manual reset switch-RS	A0701HM-8A	1	
0031	HI00031	power switch-RS	R415KKETOF	1	
0032	HC00295	quick terminal	JS205-110	2	
0033	HA04912	wire-RS	400mm UL1015 14AWG brown	1	
0034	HA01243	wire	300mm UL1015 14AWG brown	1	POW to AC SW
0035	HA01247	signle terminal wiring	180mm UL1015 14AWG blue	1	
0036	HA01248	signle terminal wiring	150mm UL1015 14AWG brown	1	
0037	HA04901	wire-RS	3P-3P 500mm UL2547 28AWG	1	INPUT-VRL
0038	HA04497	wire-RS	4P-4P 460mm UL2547 26AWG	1	INPUT-VRL
0039	HA04908	wire-RS	2P-2P 550mm UL1007 24AWG	1	INPUT-VRL

Rank	Part No.	Description	Specification	QTY	Remark
0040	HA04428	wire-RS	4P-4P 260mm UL2854/1007 26/24AWG	2	AMP-VRL
0041	HA01530	wire-RS	7P-7P 110mm UL1007 28AWG	1	
0042	HA04437	wire-RS	4P-4P 150mm UL1007 24AWG	2	POWER-AMP
0043	HA01554	wire-RS	5P-5P 120mm UL1007 26AWG	1	POWER-INPUT
0044	HA03545	wire	120mm UL1015 14AWG black	2	
0045	HA03347	wire	130mm UL1015 16AWG blue	2	
0046	HA03557	wire	120mm UL1015 14AWG white	2	
0047	HA02230	wire-RS	100mm UL1015 16AWG	1	
0048	AD00012	twin adhesive-RS	90*120mm_V1.0	1	
0049	NI00218	cable tie	ALT-102SB	13	
0050	HK09298	PC board	P-MAC 2.3MK VRL- DIP	1	
0001	SA00098	rectifier diode	1A/400V IN4004	1	
0002	SA00254	L.E.D	3 long foot 27	1	
0003	SA00052	L.E.D	3 round(green)long foot 26	2	
0004	SA00053	L.E.D	3 round(red)long foot 26mm	2	
0005	SA00255	L.E.D	3 long foot 27	1	
0006	NI01770	LED spacer support	LEDS-18 18mm	6	
0007	RC00469	potentiometer	A10K RV16A-30- 15FW-A10K-301	2	
0008	HC00065	connector(male)	2P 2.5mm 90 °	1	
0009	HC00066	connector(male)	3P 2.5mm 90 °	1	
0010	HC00067	connector(male)	4P 2.5mm 90 °	3	
0011	ME00052	nut	7	2	
0012	MF00060	washer	7* 12*0.5t	2	
0013	HI00008	relay	RY-12W-K 12V	1	
0014	AC00179	tin without lead-RS	M705E Sn 3Ag-0.5Cu	3.366	
0015	HK09299	PC board	P-MAC 2.3MK VRL-AI	1	
0001	RA00957	fixed resistor 1/8W	100	2	
0002	RA01531	precise resistor-RS	9.53K ±%	2	
0003	RA00976	fixed resistor 1/8W	1M	2	
0004	RA00962	fixed resistor 1/8W	1K	2	
0005	RA01337	fixed resistor 1/8W	2.2K	2	
0006	RA01350	fixed resistor 1/8W	20K	3	
0007	RA00964	fixed resistor 1/8W	3.9K M type	2	

Rank	Part No.	Description	Specification	QTY	Remark
0008	RA01695	precise resistor-RS	47.5K $\pm$ 1%	2	
0009	RA01354	fixed resistor 1/8W	68K	2	
0010	RA01370	fixed resistor 1/8W	8.2K	4	
0011	RA00965	fixed resistor 1/8W	4.7K	6	
0012	SA00093	rectifier diode	1N4148 0.5A	4	
0013	SB00034	transistor	2SC1815GR(SC43)/(TOSHIBA)	7	
0014	SB00074	transistor-RS-ACT	2N5401(TO92)/(HSMC)	2	
0015	CB00188	electrolytic capacitor	10uF/63V 5*11mm 2.5mm	4	
0016	CB00189	electrolytic capacitor	1.0uF/50V 4*5mm	4	
0017	HB02635	PCB-RS	MAC2.3MKII_VRL_VER 080104	1	
0016	CB00188	electrolytic capacitor	10uF/63V 5*11mm 2.5mm	1	
0017	HA01919	jump	5mm	1	
0018	HA01925	jump	10mm	1	
0051	HK09309	PC board	P-MAC 2.3MK -INPUT-DIP	1	
0001	SA00053	L.E.D	3 round(red)long foot 26mm	2	
0002	HC00078	connector(male)	4P 2.5mm 180 °	1	
0003	HC00076	connector(male)	2P 2.5mm 180 °	1	
0004	HC00077	connector(male)	3P 2.5mm 180 °	1	
0005	HC00079	connector(male)	5P 2.5mm 180 °	1	
0006	HC00267	connector(male)	7P 2.5mm 180 °	1	
0007	HI00128	slide switch	3-stages 16P SLB-43-10	1	
0008	HI00125	slide switch	SL20202-25Y-6mm	1	
0009	HC00112	balance MIC jack	99M-107SP-1-2 90 °PUSH	1	
0010	RA00006	metal-oxide-film resistor 1W	10	1	
0011	CB00166	electrolytic capacitor	100uF/16V 6*5mm	2	
0012	CB00192	electrolytic capacitor	10uF/16V 4*7mm	6	
0013	CB00235	electrolytic capacitor	100uF/25V 6*11mm	2	
0014	HC00108	stereo MIC jack	6.3 stereo LJB0661-6	1	
0015	AC00179	tin without lead-RS	M705E Sn 3Ag-0.5Cu	2.8404	
0016	HK09310	PC board	P-MAC 2.3MK -INPUT-SMD	1	
0001	RD00597	SMD precise resistor-RS 1/4W	100 $\pm$ 1% 1206	4	
0002	RD00257	SMD precise resistor 1/4W	150K $\pm$ 1% 1206	2	

Rank	Part No.	Description	Specification	QTY	Remark
0003	RD00246	SMD precise resistor 1/4W	1.80K $\pm$ 1% 1206	2	
0004	RD00632	SMD precise resistor-RS 1/4W	47.0 $\pm$ 1% 1206	1	
0005	RD00129	SMD fixed resistor 1/4W	0.0 $\pm$ 5% 1206	4	
0006	RD00452	SMD precise resistor 1/4W	15.0K $\pm$ 1% 1206	2	
0007	RD00399	SMD precise resistor 1/4W	10.0K $\pm$ 1% 1206	15	
0008	RD00428	SMD fixed resistor 1/4W	680 $\pm$ 5% 1206	2	
0009	RD00655	SMD fixed resistor-RS	39K $\pm$ 5% 1206	2	
0010	RD00656	SMD precise resistor 1/4W	4.7K $\pm$ 1% 1206	2	
0011	RD00657	SMD precise resistor 1/4W	20K $\pm$ 1% 1206	4	
0012	RD00658	SMD precise resistor-RS 1/4W	270.0 $\pm$ 1% 1206	2	
0013	RD00659	SMD ceramic capacitor 1206	22PF/-50V NPO	7	
0014	RD00660	SMD ceramic capacitor 1206	470PF/50V NPO	2	
0015	RD00661	SMD precise resistor-RS 1/4W	8.20K $\pm$ 1% 1206	2	
0016	RD00662	SMD ceramic capacitor 1206	0.1uF/50V X7R	8	
0017	RD00663	SMD ceramic capacitor 1206	0.22uF/25V X7R $\pm$ 0%	4	
0018	RD00664	transistor	MMBT3906(SOT23)/(PHI)	2	
0019	RD00665	integrated circuit-RS	UTC4580M(4580M (SOP8)/(YW)	3	
0020	RD00666	SMD integrated circuit	NJM13700M(SSOP16)/(JR C)	1	
0021	RD00667	SMD rectifier diode	RLS4148 0.5A (LL-34)	8	
0022	RD00668	PC board	P-MAC 2.3MK -INPUT- AI	1	
0023	RD00678	SMD precise resistor 1/4W	1.00K $\pm$ 1% 1206	2	
0052	RD00679	PC board-RS	P-MAC2.4 MK _CHB- INPUT	1	
0053	RD00687	PC board	P-MAC2.3MK POWER- DIP	1	
0059	RD00826	dessicant	30g	1	
0060	RD00827	clip-chain bag	0.04t*100*150mm_V1.0	1	warranty
0061	RD00828	PE bag-RS	0.04t*240*160mm_V1.0	1	user s manual
0062	RD00829	clip-chain bag	5*7	1	adhesive foot pad
0063	RD00830	PE bag-RS	0.05t*650*550mm_V1.0	1	
0064	RD00831	cushion	MAC V1.0	2	

Rank	Part No.	Description	Specification	QTY	Remark
0065	RD00832	inner case-RS	MAC SERIES ALTO V1.2	1	
0066	RD00833	carton	MAC ALTO_V1.0	1	
0067	RD00834	user manual-RS	MAC SERIES MK ALTO V1.2	1	
0068	RD00836	power cord Europe 3P	LT-312+LT-501	1	
0069	RD00837	AC socket	SS-120-E-4.8-V2	1	
0070	RD00838	PC board	P-PSA3900_V2_OUT	1	
0071	RD00852	chassis-RS	MAC2.3/2.4 MK _V1.0	1	
0072	RD00861	top cover-RS	PSA-3900-V2_V1.0	1	
0073	RD00867	label-RS	PSA-3900_V2 220- 240V V1.0	1	
0074	RD00870	screw	M3*8	8	fixed amplifier module
0075	RD00871	caushion-RS	NX55PKIT 6.85* 3*1.28	1	fixed bridging rectifier
0076	RD00872	washer-RS	5.3* 1.*0.6t	4	lock OUT PC board*4
0077	RD00873	copper pillar	M3*11*0.5PH	4	lock POWERPC board*4
0078	RD00874	screw	M3*10	1	fixed bridging rectifier
0079	RD00875	washer	1* 11.3* 15.3 red	2	
PI02093		STEREO AMPLIFIER	MAC 2.2 MK ALTO 230V	1	
0001	MA05420	panel	MAC 2.2 ALTO_V1.1	1	
0002	MA07429	panel-RS	MAC2.4 MK _V1.0	1	
0003	TD00685	transformer-RS	PT-MAC2.2MK 220/230/240V	1	
0004	MI02436	handle	MAC2.2 V1.0	2	
0005	NI00437	rubber coil	20* 120*2tB	2	
0006	NI00252	sleeve	4*20mm	3	1.AC connector
0007	NI00002	plastic nut-RS	7/16**G20/15*4.8	2	
0008	NI02650	knob	18*18mm V1.1	2	
0009	NI02651	knob fixsheath	10* 22.5	2	
0010	ND00410	dust-proof shade	167.3*85.6*5.0t_V1.1	1	
0011	ND00409	dust-proof shade	167.3*85.6*5.0t_V1.1	1	
0012	NI00389	plastic washer	12* 16*0.5	2	
0013	MG00025	screw-RS	M3*6	20	upper cover*13, panel*7
0014	MG00289	screw	M4*12	6	handle*6
0015	MG00042	screw	M3*10	4	speak-on connector*4
0016	MG00162	screw	M3*8	7	POW*4,VRL*3
0017	MG00327	screw	M3*10*0.5PH	4	MIC connector*4
0018	MG00014	hexagon screw	M10*25*1.5PH	2	
0019	MG00607	screw	M5*10	8	1.fan
0020	MG00535	screw	M5*6 V1.0	4	OUT*4
0021	MG00534	copper pillar	M5*16 V1.0	4	OUT*4
0022	MF00039	washer	5* 8*1t	4	OUT*4



Rank	Part No.	Description	Specification	QTY	Remark
0023	MF00038	washer-RS	4* 7*1t	1	ground
0024	MF00048	washer-RS	4* 8*0.5t	1	ground
0025	MF00037	washer	3.2* 5.5*1t	4	panel
0026	ME00016	color nut	4m/m	1	ground
0027	ME00015	color nut	3m/m	4	panel
0028	MF00044	washer	10* 16*2t	2	fix PT
0029	HE00086	fan-RS	DC12V/2500RPM 80*80*25mm 320mm JST2 5 2P	2	
0030	HI00140	manual reset switch-RS	A0701HM-6A	1	
0031	HI00031	power switch-RS	R415KKETOF	1	
0032	HC00295	quick terminal	JS205-110	2	
0033	HA04912	wire-RS	400mm UL1015 14AWG brown	1	
0034	HA01243	wire	300mm UL1015 14AWG brown	1	POW to AC SW
0035	HA01247	signle terminal wiring	180mm UL1015 14AWG blue	1	
0036	HA01248	signle terminal wiring	150mm UL1015 14AWG brown	1	
0037	HA04901	wire-RS	3P-3P 500mm UL2547 28AWG	1	INPUT-VRL
0038	HA04497	wire-RS	4P-4P 460mm UL2547 26AWG	1	INPUT-VRL
0039	HA04908	wire-RS	2P-2P 550mm UL1007 24AWG	1	INPUT-VRL
0040	HA04428	wire-RS	4P-4P 260mm UL2854/1007 26/24AWG	2	AMP-VRL
0041	HA01530	wire-RS	7P-7P 110mm UL1007 28AWG	1	
0042	HA04437	wire-RS	4P-4P 150mm UL1007 24AWG	2	POWER-AMP
0043	HA01554	wire-RS	5P-5P 120mm UL1007 26AWG	1	POWER-INPUT
0044	HA03545	wire	120mm UL1015 14AWG black	2	
0045	HA03347	wire	130mm UL1015 16AWG blue	2	
0046	HA03557	wire	120mm UL1015 14AWG white	2	
0047	HA02230	wire-RS	100mm UL1015 16AWG	1	
0048	HA00861	power cord Europe 3P	LT-312+LT-501	1	
0049	AD00012	twin adhesive-RS	90*120mm_V1.0	1	
0050	NI00218	cable tie	ALT-102SB	13	
0051	HK09298	PC board	P-MAC 2.3MK VRL- DIP	1	
0001	SA00098	rectifier diode	1A/400V IN4004	1	
0002	SA00254	L.E.D	3 long foot 27	1	
0003	SA00052	L.E.D	3 round(green)long foot 26	2	
0004	SA00053	L.E.D	3 round(red)long foot 26mm	2	
0005	SA00255	L.E.D	3 long foot 27	1	

Rank	Part No.	Description	Specification	QTY	Remark
0006	NI01770	LED spacer support	LEDS-18 18mm	6	
0007	RC00469	potentiometer	A10K RV16A-30-15FW-A10K-301	2	
0008	HC00065	connector(male)	2P 2.5mm 90 °	1	
0009	HC00066	connector(male)	3P 2.5mm 90 °	1	
0010	HC00067	connector(male)	4P 2.5mm 90 °	3	
0011	ME00052	nut	7	2	
0012	MF00060	washer	7* 12*0.5t	2	
0013	HI00008	relay	RY-12W-K 12V	1	
0014	AC00179	tin without lead-RS	M705E Sn 3Ag-0.5Cu	3.366	
0015	HK09299	PC board	P-MAC 2.3MK VRL-AI	1	
0001	RA00957	fixed resistor 1/8W	100	2	
0002	RA01531	precise resistor-RS	9.53K ±%	2	
0003	RA00976	fixed resistor 1/8W	1M	2	
0004	RA00962	fixed resistor 1/8W	1K	2	
0005	RA01337	fixed resistor 1/8W	2.2K	2	
0006	RA01350	fixed resistor 1/8W	20K	3	
0007	RA00964	fixed resistor 1/8W	3.9K M type	2	
0008	RA01695	precise resistor-RS	47.5K ±%	2	
0009	RA01354	fixed resistor 1/8W	68K	2	
0010	RA01370	fixed resistor 1/8W	8.2K	4	
0011	RA00965	fixed resistor 1/8W	4.7K	6	
0012	SA00093	rectifier diode	1N4148 0.5A	4	
0013	SB00034	transistor	2SC1815GR(SC43)/(TOSHIBA)	7	
0014	SB00074	transistor-RS-ACT	2N5401(TO92)/(HSMC)	2	
0015	CB00188	electrolytic capacitor	10uF/63V 5*11mm 2.5mm	4	
0016	CB00189	electrolytic capacitor	1.0uF/50V 4*5mm	4	
0017	HB02635	PCB-RS	MAC2.3MKII_VRL_VER 080104	1	
0016	CB00188	electrolytic capacitor	10uF/63V 5*11mm 2.5mm	1	
0017	HA01919	jump	5mm	1	
0018	HA01925	jump	10mm	1	
0052	HK09309	PC board	P-MAC 2.3MK -INPUT-DIP	1	
0001	SA00053	L.E.D	3 round(red)long foot 26mm	2	
0002	HC00078	connector(male)	4P 2.5mm 180 °	1	
0003	HC00076	connector(male)	2P 2.5mm 180 °	1	

Rank	Part No.	Description	Specification	QTY	Remark
0004	HC00077	connector(male)	3P 2.5mm 180 °	1	
0005	HC00079	connector(male)	5P 2.5mm 180 °	1	
0006	HC00267	connector(male)	7P 2.5mm 180 °	1	
0007	HI00128	slide switch	3-stages 16P SLB-43-10	1	
0008	HI00125	slide switch	SL20202-25Y-6mm	1	
0009	HC00112	balance MIC jack	99M-107SP-1-2 90 °PUSH	1	
0010	RA00006	metal-oxide-film resistor 1W	10	1	
0011	CB00166	electrolytic capacitor	100uF/16V 6*5mm	2	
0012	CB00192	electrolytic capacitor	10uF/16V 4*7mm	6	
0013	CB00235	electrolytic capacitor	100uF/25V 6*11mm	2	
0014	HC00108	stereo MIC jack	6.3 stereo LJB0661-6	1	
0015	AC00179	tin without lead-RS	M705E Sn 3Ag-0.5Cu	2.8404	
0016	HK09310	PC board	P-MAC 2.3MK -INPUT-SMD	1	
0001	RD00597	SMD precise resistor-RS 1/4W	100 ±1% 1206	4	
0002	RD00257	SMD precise resistor 1/4W	150K ±1% 1206	2	
0003	RD00246	SMD precise resistor 1/4W	1.80K ±1% 1206	2	
0004	RD00632	SMD precise resistor-RS 1/4W	47.0 ±1% 1206	1	
0005	RD00129	SMD fixed resistor 1/4W	0.0 ±5% 1206	4	
0006	RD00452	SMD precise resistor 1/4W	15.0K ±1% 1206	2	
0007	RD00399	SMD precise resistor 1/4W	10.0K ±1% 1206	15	
0008	RD00428	SMD fixed resistor 1/4W	680 ±5% 1206	2	
0009	RD00655	SMD fixed resistor-RS	39K ±5% 1206	2	
0010	RD00411	SMD precise resistor 1/4W	4.7K ±1% 1206	2	
0011	RD00413	SMD precise resistor 1/4W	20K ±1% 1206	4	
0012	RD00633	SMD precise resistor-RS 1/4W	270.0 ±1% 1206	2	
0013	CI00126	SMD ceramic capacitor 1206	22PF/-50V NPO	7	
0014	CI00041	SMD ceramic capacitor 1206	470PF/50V NPO	2	
0015	RD00601	SMD precise resistor-RS 1/4W	8.20K ± 1% 1206	2	

Rank	Part No.	Description	Specification	QTY	Remark
0016	CI00095	SMD ceramic capacitor 1206	0.1uF/50V X7R	8	
0017	CI00106	SMD ceramic capacitor 1206	0.22uF/25V X7R $\pm$ 0%	4	
0018	SF00053	transistor	MMBT3906(SOT23)/(PHI)	2	
0019	SG00558	integrated circuit-RS	UTC4580M(4580M)(SOP8)/(YW)	3	
0020	SG00014	SMD integrated circuit	NJM13700M(SSOP16)/(JRC)	1	
0021	SE00011	SMD rectifier diode	RLS4148 0.5A (LL-34)	8	
0022	HK09311	PC board	P-MAC 2.3MK -INPUT-AI	1	
0001	HA01929	jump	13mm	1	
0002	HA01930	jump	15mm	3	
0003	HA01925	jump	10mm	2	
0004	HA01927	jump-RS	11mm	2	
0005	HA01922	jump	8mm	4	
0006	HA01919	jump	5mm	5	
0007	HA01920	wire-RS	6mm	5	
0008	HA01924	jump	9mm	2	
0009	HB02636	PCB-RS	MAC2.3MK -IN(1*4)_VER080908	1	
0023	RD00245	SMD precise resistor 1/4W	1.00K $\pm$ % 1206	2	
0053	HK09109	PC board-RS	P-MAC2.4 MK _CHB-INPUT	1	
0001	AC00179	tin without lead-RS	M705E Sn 3Ag-0.5Cu	0.612	
0002	CA00033	ceramic capacitor-RS	470PF/50V Y5E	2	
0003	HB00799	PCB	CHB-PU-2_VER021004	1	
0004	HC00108	stereo MIC jack	6.3 stereo LJB0661-6	1	
0005	HC00112	balance MIC jack	99M-107SP-1-2 90 °PUSH	1	
0006	HC00267	connector(male)	7P 2.5mm 180 °	1	
0007	HI00125	slide switch	SL20202-25Y-6mm	1	
0054	HK09356	PC board	P-MAC2.2MK POWER-DIP	1	
0001	RA00157	fixed resistor 1/4W	0	1	
0002	RA01109	fixed resistor 1/4W	1K	1	
0003	SA00098	rectifier diode	1A/400V IN4004	4	
0004	SA00256	zener diode	1W 15V IN4744	2	
0005	RA00241	fixed resistor 1/4W	10K F type	2	
0006	HA01925	jump	10mm	4	
0007	HA01921	jump	7mm	1	
0008	HA01928	jump	12mm	2	
0009	RA01801	metal-oxide-film resistor-RS 1W	0.22	3	
0010	CA00082	ceramic capacitor-RS	0.1uF/100V Y5V	2	

Rank	Part No.	Description	Specification	QTY	Remark
0011	CF00033	metal-film capacitor MEF	0.1uF/250V 10%	8	
0012	CB00274	electrolytic capacitor	470uF/35V 10*20mm 5mm	2	
0013	CB00235	electrolytic capacitor	100uF/25V 6*11mm	2	
0014	CB00234	electrolytic capacitor	10uF/50V 6*7mm	1	
0015	CB00079	electrolytic capacitor	2200uF/25V 13*25mm	2	
0016	CB00056	electrolytic capacitor	220uF/25V 8*11mm	3	
0017	CB00351	electrolytic capacitor-RS	6800uF/80V 85 30*45mm	2	
0018	HC00324	connect terminal	6.5m/m (PC250)	19	
0019	CG00044	metal oxide varistors	NP35L-Y2	2	
0020	SD00077	integrated circuit-RS	L7815CV(TO220)/(ST/MO ROCCO)	1	
0021	SB00179	transistor-RS-ACT	2SA1013(TO- 92MOD)/(TOSHIBA)	1	
0022	SB00178	transistor-RS-ACT	2SA1837(TO- 220MOD)/(TOSHIBA)	1	
0023	SB00164	transistor	2SC4793(TO220MOD)/(T OSHIBA)	1	
0024	SB00180	transistor-RS-ACT	2SC2383(TO- 92MOD)/(TOSHIBA)	1	
0025	HC00079	connector(male)	5P 2.5mm 180 °	2	
0026	HC00076	connector(male)	2P 2.5mm 180 °	2	
0027	HC00078	connector(male)	4P 2.5mm 180 °	2	
0028	HC00063	FUSE holder	JEF-501 (5.2mm)	4	
0029	SA00252	bridge rectifier	35A/1000V BP-3506PWS	1	
0030	SA00221	bridge rectifier	2A/600V KBP206	2	
0031	SD00032	integrated circuit	LM317T(TO220)/(ST)	1	
0032	MI00256	heat-sink	25*15*10.6-1PIN SCL- 2020	1	
0033	MG00020	screw	M3*8	1	
0034	MF00037	washer	3.2* 5.5*1t	1	
0035	HD00112	glass tube fuse-RS- slow(spiral)	T10A 250V 5.2*20mm UL/VDE	2	
0036	AC00179	tin without lead-RS	M705E Sn 3Ag-0.5Cu	3.582	
0037	HB02637	PCB-RS	MAC2.3MK POWER_VER080812	1	
0038	CG00026	X2 capacitor	0.22uF/275VAC (PHE 840/830)PH22.5mm	1	
0039	HA01919	jump	5mm	4	
0055	HK09300	PC board	P-MAC2.2MK AMP-DIP	2	

Rank	Part No.	Description	Specification	QTY	Remark
0001	SA00197	zener diode	1W 36V 1N4753	4	
0002	SA00168	zener diode	1W 5.6V 1N4734	1	
0003	SA00159	rectifier diode	1A/1000V IN4007	6	
0004	CB00327	electrolytic capacitor-RS	22uF/100V 8*12mm	4	
0005	CB00171	electrolytic capacitor	220uF/16V NP 10*12.5mm	1	
0006	CB00027	electrolytic capacitor	22uF/50V 6.3*11mm NP	1	
0007	HC00078	connector(male)	4P 2.5mm 180 °	2	
0008	HC00076	connector(male)	2P 2.5mm 180 °	1	
0009	RA00031	metal-oxide-film resistor 2W	10 P type	2	
0010	RA00980	metal-oxide-film resistor 3W	10 P type	1	
0011	RA01453	chassis bracket 5W	0.22 ±5% SQP	6	
0012	HI00160	relay	4P DC-12V 832A-1A-C	1	
0013	SB00147	transistor-RS	2SC4382(TO220)/(SANKE N)	2	
0014	SB00148	transistor-RS	2SA1668(TO220)/(SANKE N)	2	
0015	SB00060	transistor-RS-ACT	MJE340(SOT32)/(ST)	2	
0016	SB00061	transistor-RS-ACT	MJE350(SOT32)/(ST)	3	
0017	RH00028	thermistor	500 (NDA05C150L-W)	1	
0018	HC00324	connect terminal	6.5m/m (PC250)	5	
0019	CN00028	inductance-RS	10*21.8mm	1	
0020	HI00290	thermal switch	NO85 U-A	1	
0021	HA01955	wire-RS	2P 150mm UL1007 26AWG	1	CN3 to thermostat SW
0022	NI00260	sleeve	5*10mm	2	thermostat SW*2
0023	MF00156	caushion-RS	NX55PKIT 6.85* 3*1.28	10	
0024	NC00004	mica-RS	29*22*0.11mm	6	power chip*6
0025	MG00171	screw	M3*14	9	chip*9
0026	SB00247	transistor-RS	2SA970GR-TR	2	
0027	AC00179	tin without lead-RS	M705E Sn 3Ag-0.5Cu	6.678	
0028	MI04659	heat-sink-RS	MAC2.3 MK 150*79*59.5_V1.3	1	
0029	HK09477	PC board	P-MAC2.2MK AMP-AI	1	
0001	HA01925	jump	10mm	9	
0002	HA01931	jump	16mm	1	
0003	HA01920	wire-RS	6mm	1	
0004	RA01112	fixed resistor 1/4W	100	4	
0005	RA01111	fixed resistor 1/4W	100K	3	
0006	RA01113	fixed resistor 1/4W	10K	6	
0007	RA01205	precise resistor 1/4W	9.09K ±%	2	

Rank	Part No.	Description	Specification	QTY	Remark
0008	RA01109	fixed resistor 1/4W	1K	5	
0009	RA01322	precise resistor 1/4W	200 ±%	2	
0010	RA01115	fixed resistor 1/4W	20K	1	
0011	RA01346	precise resistor 1/4W	2.7K ±%	2	
0012	RA00198	fixed resistor 1/4W	300	2	
0013	RA01283	fixed resistor 1/4W	330	1	
0014	RA01275	fixed resistor 1/4W	39K	2	
0015	RA00805	fixed resistor 1/4W	68K	1	
0016	RA01234	fixed resistor 1/4W	4.7K	2	
0017	RA01259	fixed resistor 1/4W	47	4	
0018	RA01122	fixed resistor 1/4W	47K	3	
0019	RA00277	fixed resistor 1/4W	82K	1	
0020	RA00178	fixed resistor 1/4W	68	2	
0021	RA00209	fixed resistor 1/4W	680	1	
0022	RA01204	precise resistor 1/4W	887 ±%	1	
0023	RA01238	fixed resistor 1/4W	6.8K	3	
0024	SA00093	rectifier diode	1N4148 0.5A	9	
0025	CB00260	electrolytic capacitor	47uF/35V 5*11mm 2.5mm	1	
0026	CB00237	electrolytic capacitor	1.0uF/50V 5*11mm 2.5mm	1	
0027	CB00190	electrolytic capacitor	4.7uF/25V 4*7mm	1	
0028	CB00235	electrolytic capacitor	100uF/25V 6*11mm	1	
0029	CF00155	metal-film capacitor MSC	0.22uF/63V 5% CASE02	2	
0030	CA00119	ceramic capacitor-RS	220PF/1000V Y5P	2	
0031	CA00012	ceramic capacitor-RS	33PF/50V NPO	2	
0032	CA00122	ceramic capacitor-RS	100PF/100V NPO	4	
0033	CA00130	ceramic capacitor-RS	10PF/100V Y5P	2	
0034	SB00047	transistor	2SC2240GR	2	
0035	SB00074	transistor-RS-ACT	2N5401(TO92)/(HSMC)	3	
0036	SB00073	transistor-RS-ACT	2N5550/2N5551(TO92)/(HSMC)	8	
0037	HB02638	PCB-RS	MAC2.3MK AMP VER081022	1	
0038	HA01928	jump	12mm	2	
0039	HA01927	jump-RS	11mm	1	
0040	RA01114	fixed resistor 1/4W	2.2K	1	
0030	MG00041	screw	M3*6	2	

Rank	Part No.	Description	Specification	QTY	Remark
0031	RA01205	precise resistor 1/4W	9.09K ±%	1	
0032	SB00021	power transistor	2SC5200	3	
0033	SB00023	power transistor	2SA1943-O	3	
0034	CF00033	metal-film capacitor MEF	0.1uF/250V 10%	2	
0035	NC00080	washer	3.17* 8.2*1	1	fix Q19 MJE350
0036	MG00269	screw-RS	M3*6	5	PC board*4,thermistor*1
0037	MG00461	copper pillar	M3*7.3*0.5PH	4	
0056	NI01867	self-adhere foot cushion	20.5*14*7.6mm(SF-006)	4	
0057	NE11347	label-RS	ALTO PI_V1.2	4	mainframe , inner box,outer box,warranty,
0058	NF00061	assurance card-RS-C	ALTO_V1.1	1	
0059	NE05633	label	MAC 2.2_V1.0	4	mainframe , inner box,outer box,warranty,
0060	HJ00006	dessicant	30g	1	
0061	NA00279	clip-chain bag	0.04t*100*150mm_V1.0	1	warranty
0062	NA00858	PE bag-RS	0.04t*240*160mm_V1.0	1	user s manual
0063	NA00137	clip-chain bag	5*7	1	
0064	NA00890	PE bag-RS	0.05t*650*550mm_V1.0	1	
0065	NB03191	cushion	MAC V1.0	2	
0066	NB03188	inner case-RS	MAC SERIES ALTO V1.2	1	
0067	NB03187	carton	MAC ALTO_V1.0	1	
0068	NF03010	user manual-RS	MAC SERIES MK ALTO V1.2	1	
0069	NE19250	label-RS	PSA-3600_V2 220- 240V V1.0	1	mainframe
0070	MC01113	top cover-RS	PSA-3900-V2_V1.0	1	
0071	MB06330	chassis-RS	MAC2.3/2.4 MK _V1.0	1	
0072	HK10550	PC board	P-PSA3900_V2_OUT	1	
0001	RA00074	metal-oxide-film resistor 3W	4.7 RSS P type	2	
0002	CF00033	metal-film capacitor MEF	0.1uF/250V 10%	2	
0003	HA01237	signle terminal wiring CF:W207	200mm UL1015 14AWG grey	1	SPKA-
0004	HA03662	signle terminal wiring	150mm UL1015 14AWG write	1	SPKA+
0005	HA01238	signle terminal wiring CF:W208	250mm UL1015 14AWG grey	1	SPKB-



Rank	Part No.	Description	Specification	QTY	Remark
0006	HA04417	wire-RS	200mm UL1015 14AWG White	1	SPKB+
0007	HA01925	jump	10mm	2	
0008	MJ00942	fixed bracket	CS12/600_V1.3	2	
0009	HC00949	speaker socket-RS-C	LD4015	2	
0010	AC00179	tin without lead-RS	M705E Sn 3Ag-0.5Cu	0.432	
0011	HB02946	PCB-RS	PG2200 OUT(1*3)_VER081127	1	
0073	MF00149	washer-RS	5.3* 1.*0.6t	4	lock OUT PC board*4.
0074	HC00624	AC socket	SS-120-E-4.8-V2	1	
0075	MG00020	screw	M3*8	8	
0076	MF00156	caushion-RS	NX55PKIT 6.85* 3*1.28	1	fix bridging rectifier
0077	MG00585	copper pillar	M3*11*0.5PH	4	lock POWERPC board*4.
0078	MG00167	screw	M3*10	1	fix bridging rectifier
0079	NC00131	washer	1* 11.3* 15.3 red	2	