

# **Service** *Manual*

**MODEL: MISTRAL 6000**



[www.altoproaudio.com](http://www.altoproaudio.com)

Version 2.0

## CONTENTS

<b>1. Introduction.....</b>	<b>2</b>
<b>2. Specification.....</b>	<b>3</b>
<b>3. Schematic Diagram.....</b>	<b>4</b>
<b>4. Wiring Diagram.....</b>	<b>11</b>
<b>5. PCB Layout.....</b>	<b>13</b>
<b>6. Test Procedure.....</b>	<b>18</b>
<b>7. Exploded Views &amp; Mechanical Parts List.....</b>	<b>20</b>
<b>8. BOM.....</b>	<b>23</b>

## 1. Introduction

ALTO MISTRAL amplifiers are series of innovative design power amplifiers. This series work under high stability with great power supply in just 2-rack spaces. Airflow is from back to front panel to keep in a nice air circulation inside the Rack. The automatic fan, which affects the temperature of machine includes various kinds of speed, therefore, this low-noise fan makes a good result in cooling the heat from machines. MISTRAL amplifiers include 2 independent channels with separate protection system and power supply. The independent protection system avoids opening circuit, short, and wrong loading or over-heating. The special-designed protective system applies automatically restarting functions upon the default status and then goes back to normal. All electronic inputs equip standard power connectors. And all inputs are electronic balanced, with hi-quality transformer, MISTRAL amplifiers provide an outstanding performance in any conditions.

Innovative design and high stability power amplifiers.

Fan-cooled AB class high power amplifier in 19"rack, 2Usize

Rugged amplifiers in a strong, compact chassis.

2 independent channels with separate protection system and power supply

Smart-designed protection system for auto re-operation after fault.

Auto-adjusting speed fan.

4LEDs for operation/protection, limit, power on and clip

High-current toroidal transformer designed for high power at 2Ohms with low noise.

Independent DC and thermal overload protection on each channel.

IEC standard power connectors.

Binding post and NEUTRIK® SPEAKON outputs power connectors.

Balanced XLR inputs/ parallel outputs.

MODEL	MISTRAL6000
20Hz 20KHz@0.1%THD, Stereo Mode	
8 ohms per channel(EIAJ)	1070W
4 ohms per channel (EIAJ)	1500W
Bridge Mono Mode	
8 ohms, 1KHz, 0.1% THD (EIAJ)	3000W
Distortion (SMPTE-IM)	<0.05%
Frequency Response	20Hz-20KHz 1dB, -3dB points: 10Hz-60KHz
Damping Factor, 1KHz and below	>400 at 8ohms
Signal to Noise, 20Hz-20KHz	110dB
Voltage Gain	40 (31dB)
Input Sensitivity @ 4 ohms	6Vrms
Input Clipping	10Vrms (+22dB)
Input Impedance	10K ohms unbalanced, 20k ohms balanced 56 (36dB)
Controls	Front: AC switch, CH1 & CH2 Gain Knobs Rear: Limiter, Bridge selector
Indications (1 per channel)	Power-on blue LED Operation / Protection : Dual color (Green/Red LED) Limit: Red LED Clip: Red LED
Connectors, each channel	Input: Active balanced XLR Parallel output: XLR Output NEUTRIK® Spoken and Binding posts
Cooling	Continuously variable-speed fan, rear-to –front air flow
Load Protection	On / off muting, DC-fault load grounding relay: internal fault fuses
Power requirements	200-240 (100-120) Vac 50~60Hz
Dimensions	19" (48.3cm) rack mounting, 5.2" (13.3cm) tall (3 rack spaces) 17.8" (45.3cm) deep (rack mounting to rear support ears)
Net Weight	26.47Kg

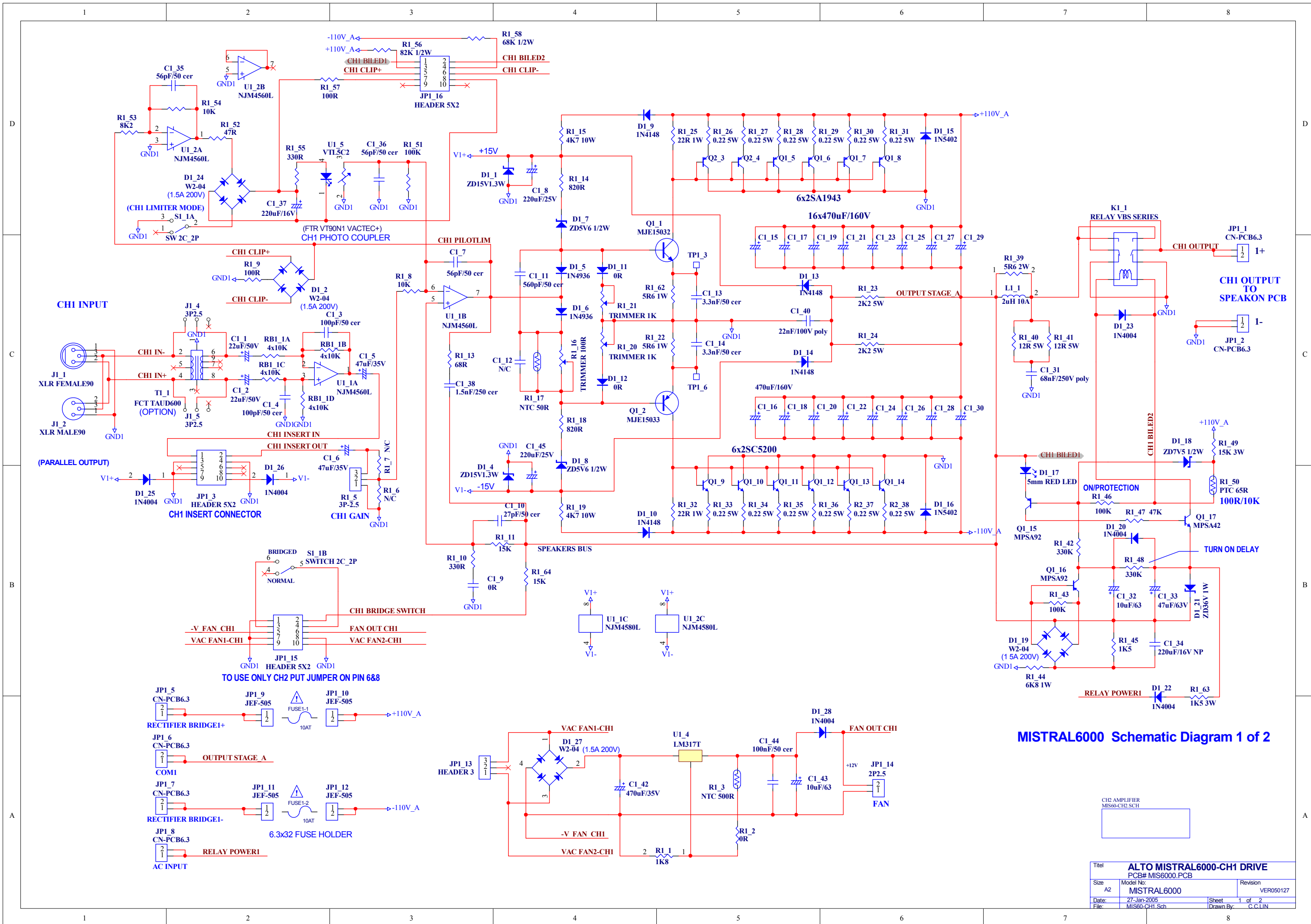

MISTRAL6000 Schematic Diagram 1 of 2

Titel			ALTO MISTRAL6000-CH1 DRIVE		
PCB#			MIS6000.PCB		
Size	Model No.	Revision			
A2	MISTRAL6000	VER050127			
Date:	27-Jan-2005	Sheet	1 of 2		
File:	MIS60-CH1.Sch	Drawn By:	C.C.LIN		



D

C

B

A

D

C

B

A

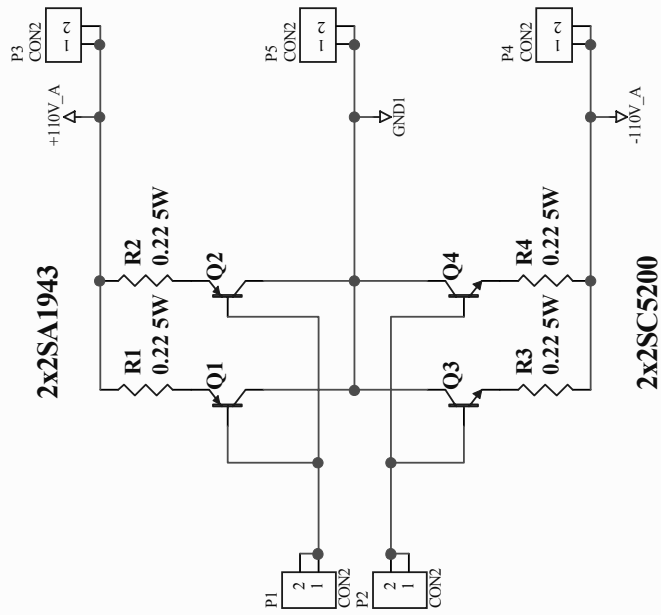

Titel **ALTO : MISTRAL6000 MAIN2-BOARD**

Size	A2	Model No:	MISTRAL6000	Revision	VER060127
Date:	27-Jan-2005	File:	MIS60MN2.Sch	Sheet	1 of 1
				Drawn By:	C.CLIN

D

C

B

A

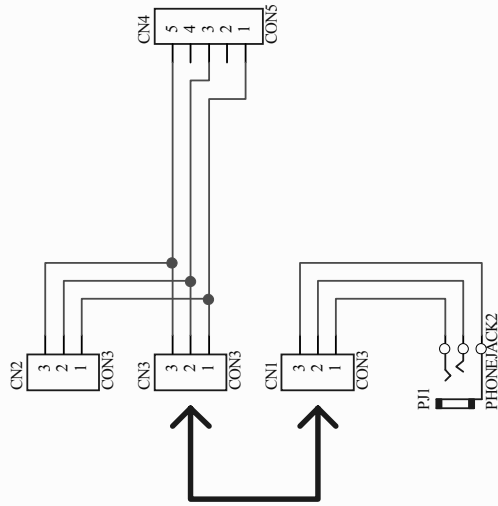

### ALTO : MISTRAL4000 INPUT

Titel	ALTO : MISTRAL4000 INPUT		
Size	A4	Model No:	MISTRAL4000
		Revision	VER031206
Date:	27-Jan-2005	Sheet	1 of 1
File:	MIS40IN.Sch	Drawn By:	C.C.LIN

D

C

B

A



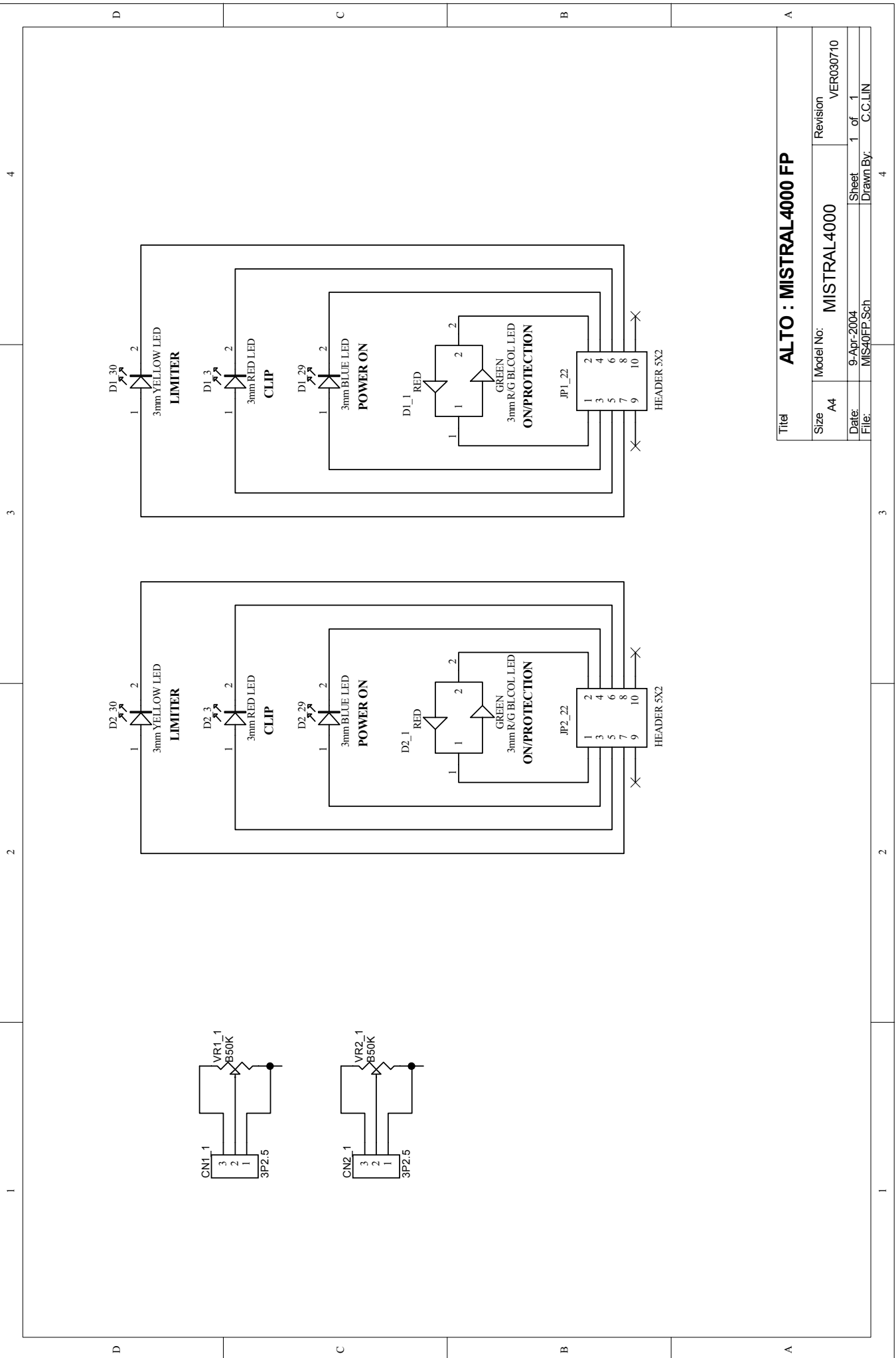

Title		<b>ALTO : MISTRAL4000 FP</b>	
Size	A4	Model No:	MISTRAL4000
		Revision	VER030710
Date:	9-Apr-2004	Sheet	1 of 1
File:	MIS40FP.Sch	Drawn By:	C.C.LIN

4

3

2

1

3

2

1

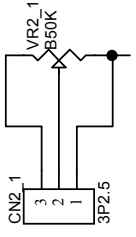
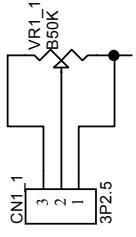
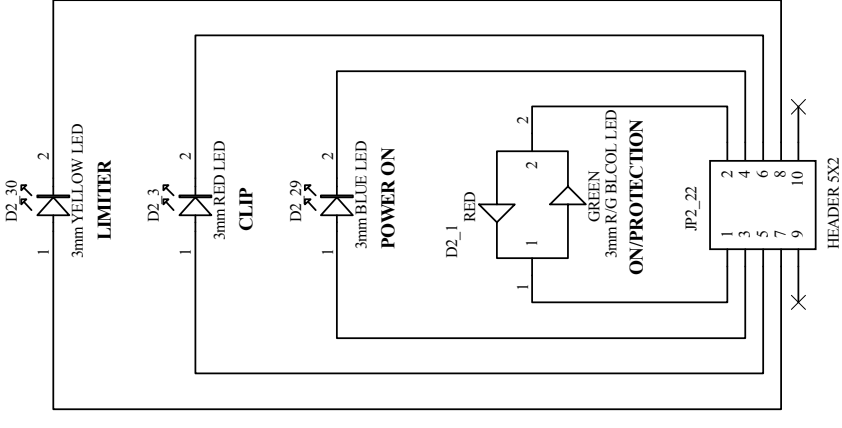
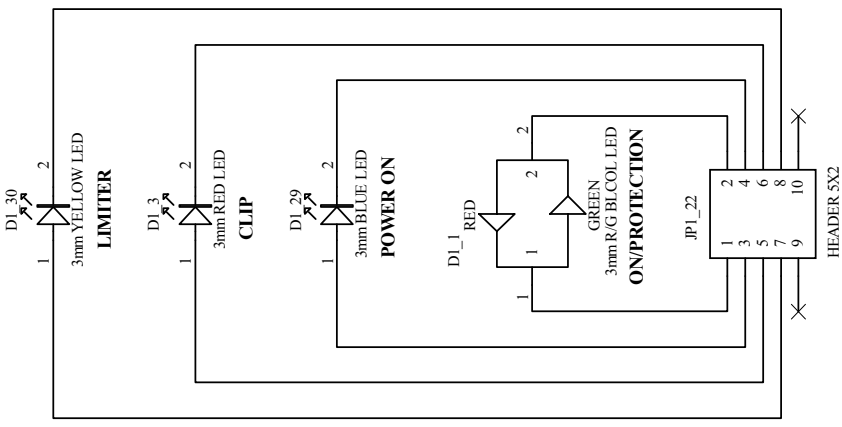

D

C

B

A

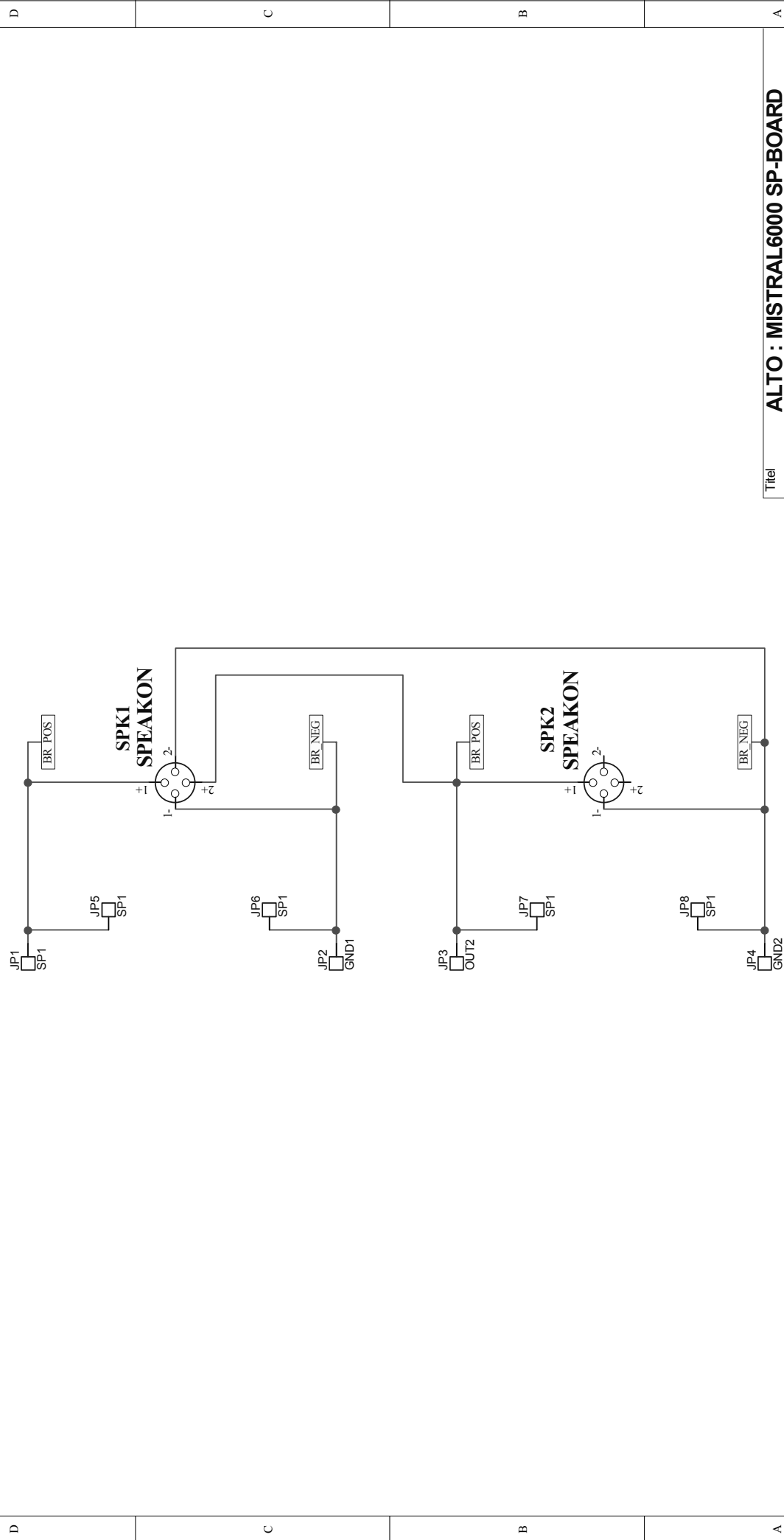

**Titel** ALTO : MISTRAL6000 SP-BOARD

Size	A2	Model No:	MISTRAL6000	Revision	VER060127
Date:	27-Jan-2005	Sheet	1 of 1	Drawn By:	C.CLIN
File:	MIS60SP.Sch				

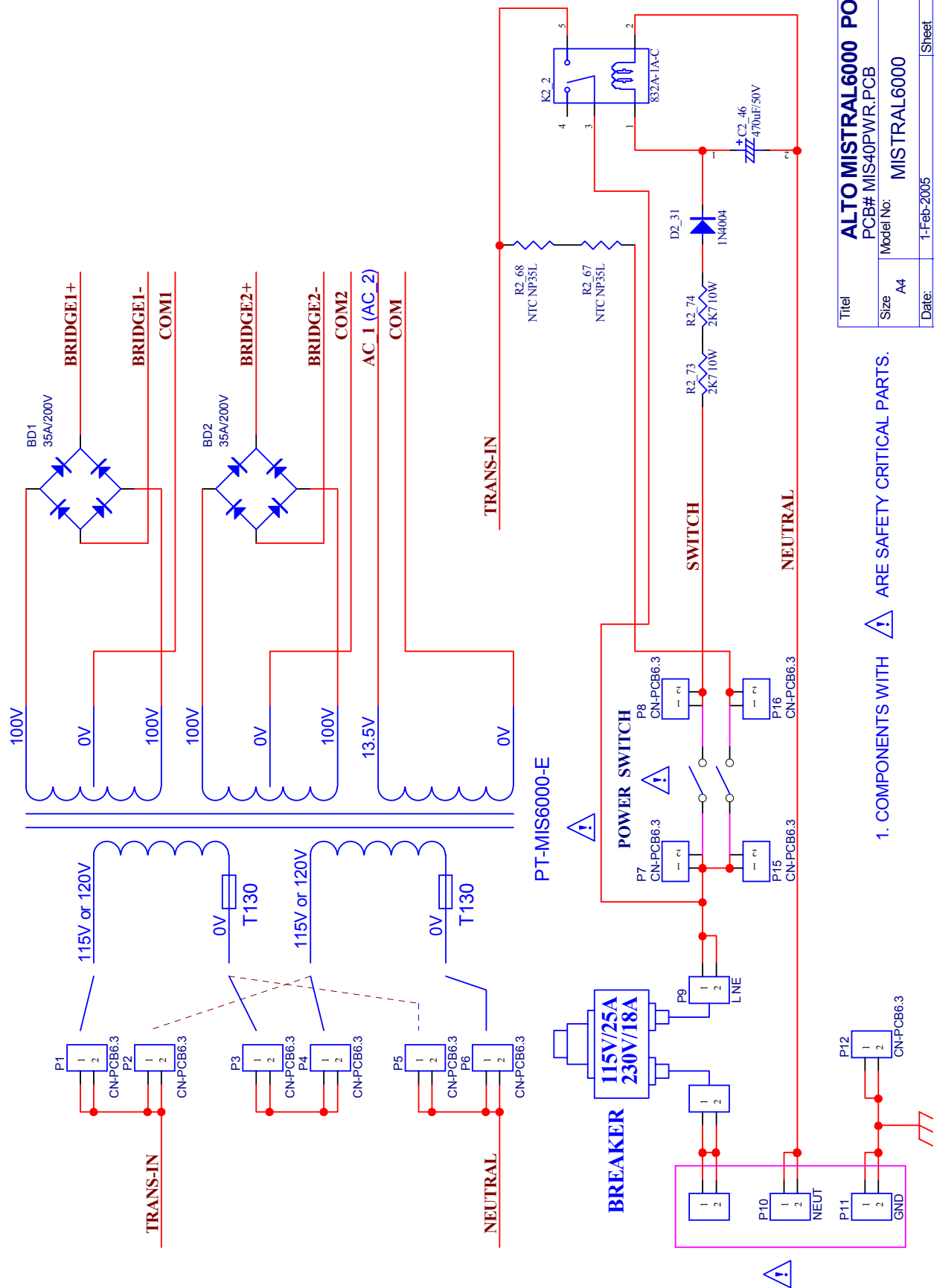

Title		<b>ALTO MISTRAL6000 POWER BOARD</b>	
Size		PCB# MIS40PWR.PCB	
Model No:	MISTRAL6000	Revision	VER060201
Date:	1-Feb-2005	Sheet	1 of 1
File:	MIS60PWR.Sch	Drawn By:	C.C.LIN

1. COMPONENTS WITH ARE SAFETY CRITICAL PARTS.

# MISTRAL6000 Chassis Wiring Drawing (100V-120V)

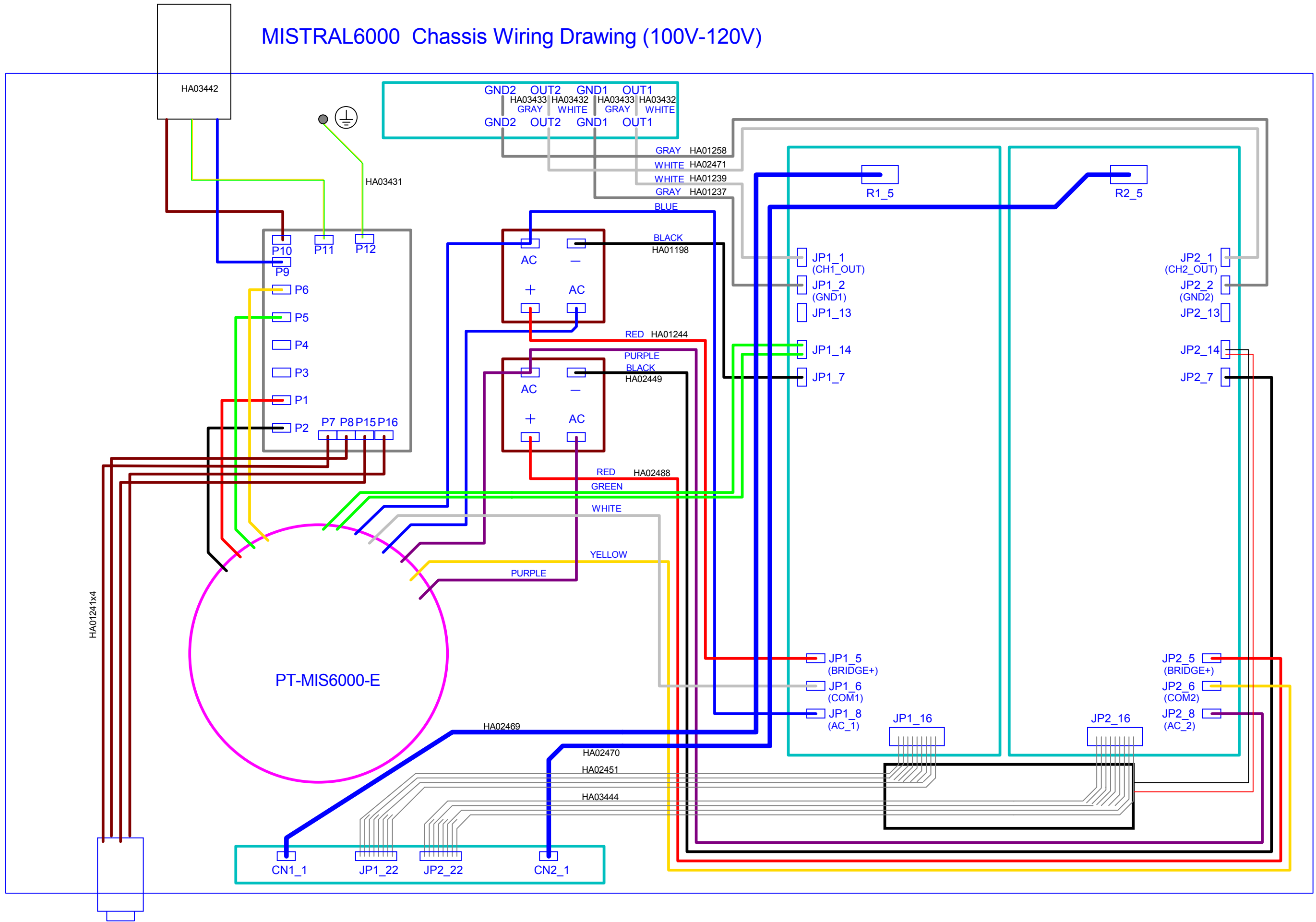

# MISTRAL6000 Chassis Wiring Drawing (220V-240V)

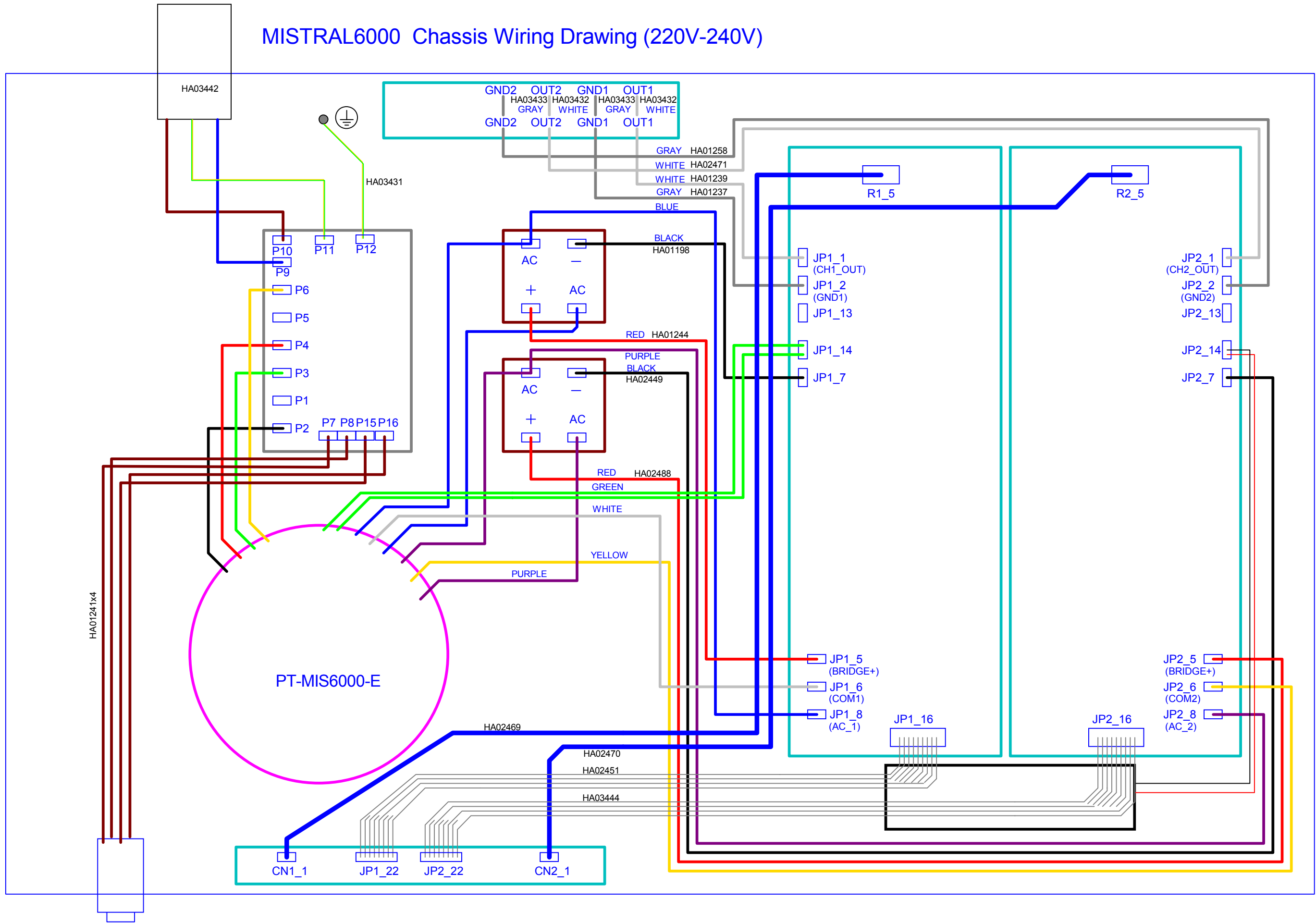

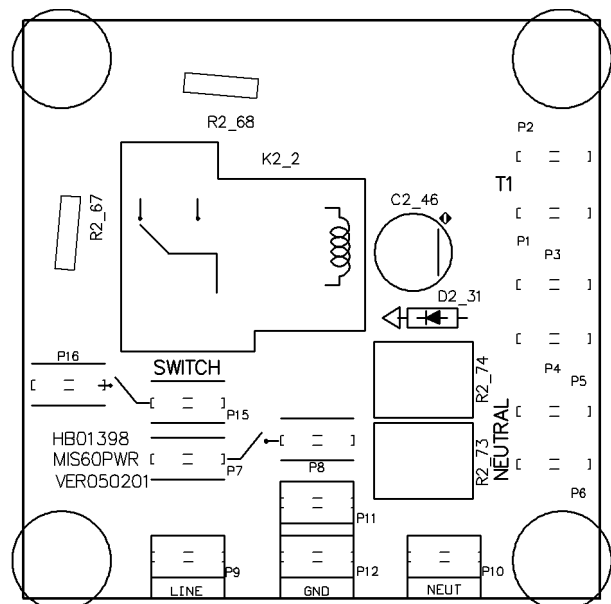
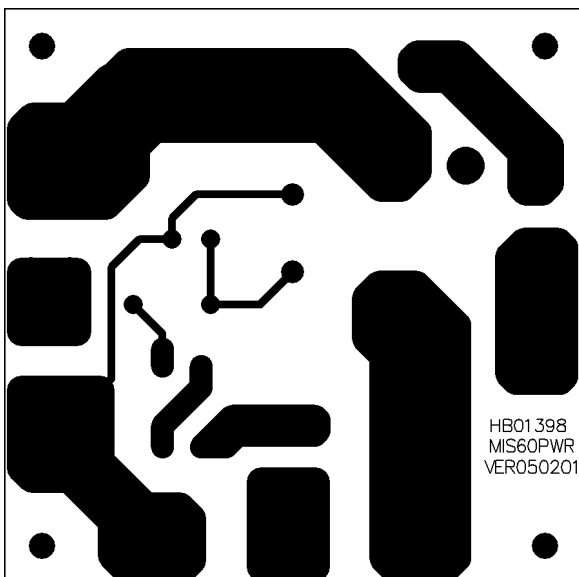
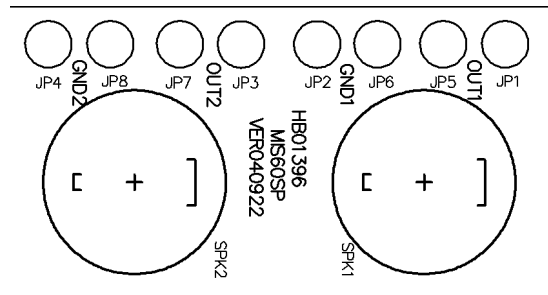
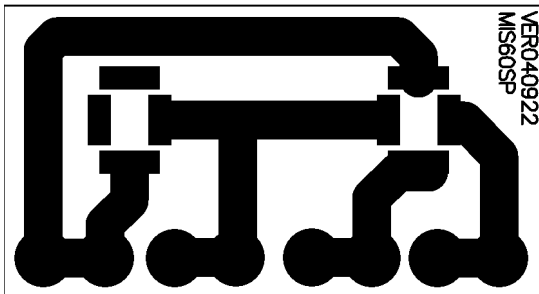
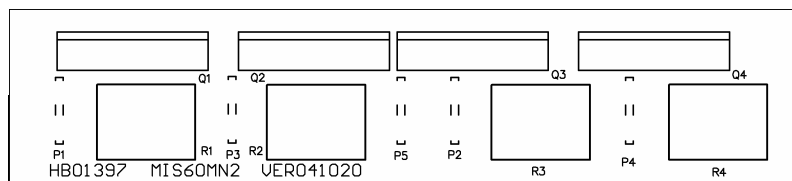
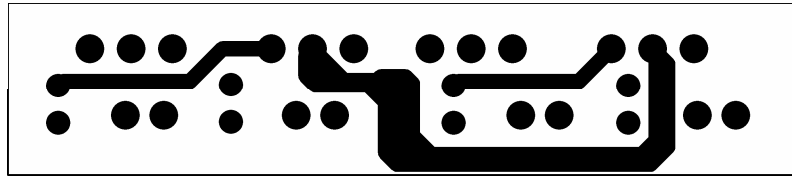
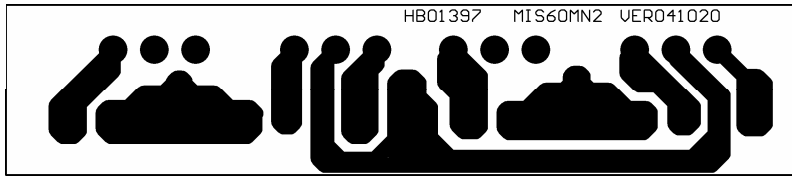

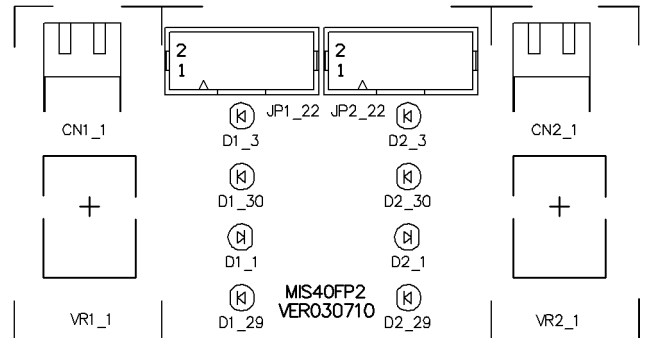
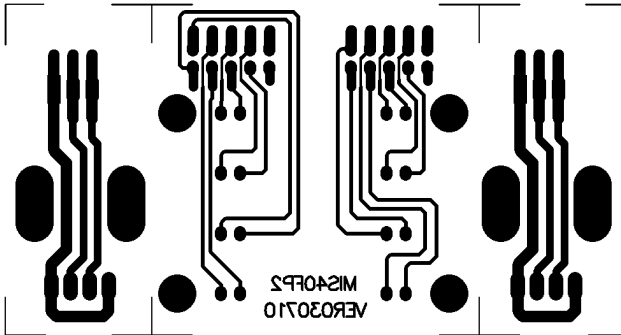
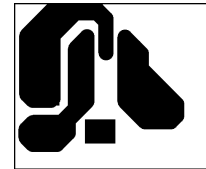
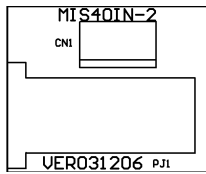
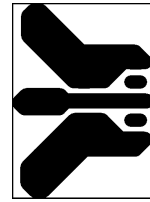
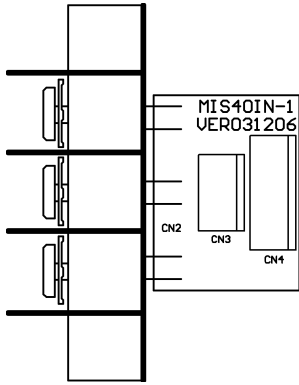

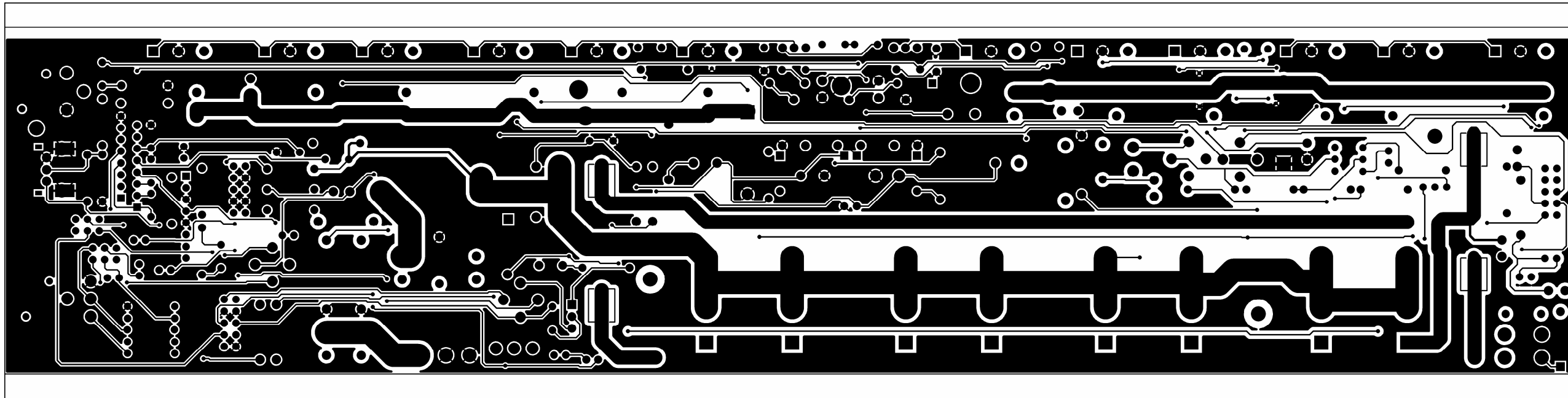
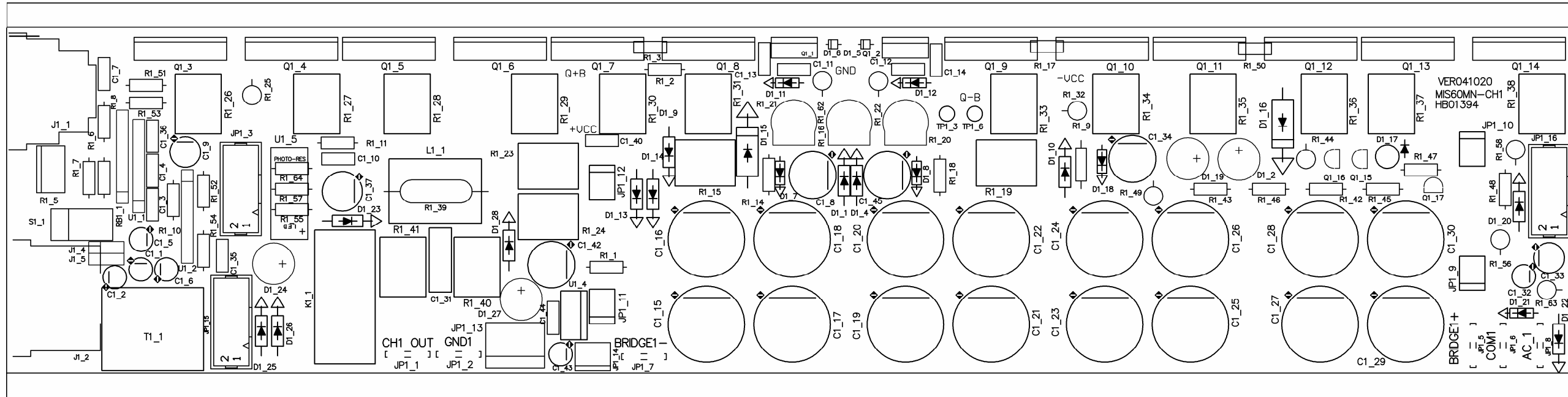





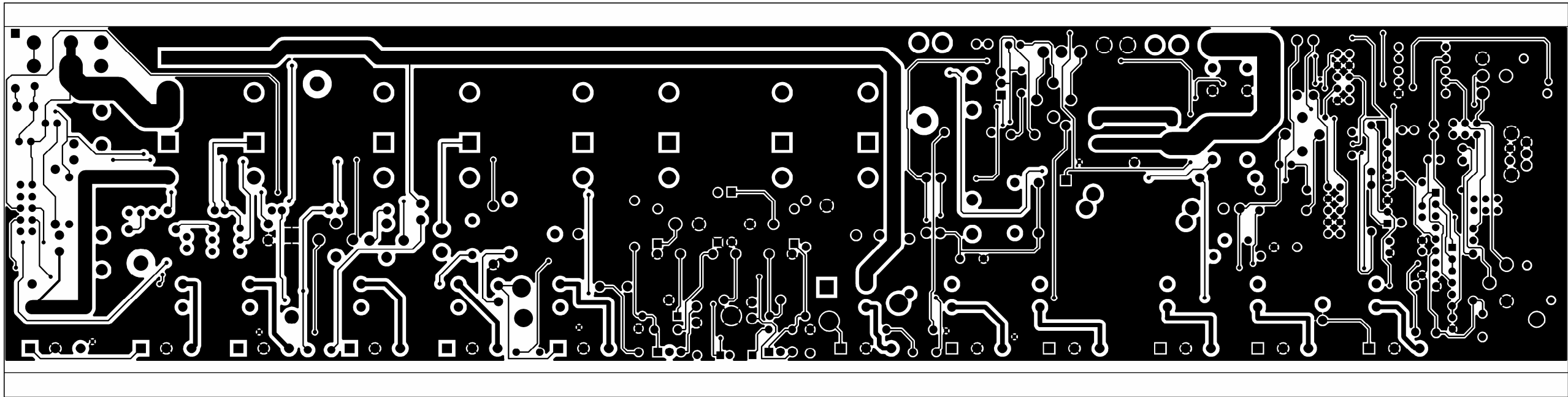
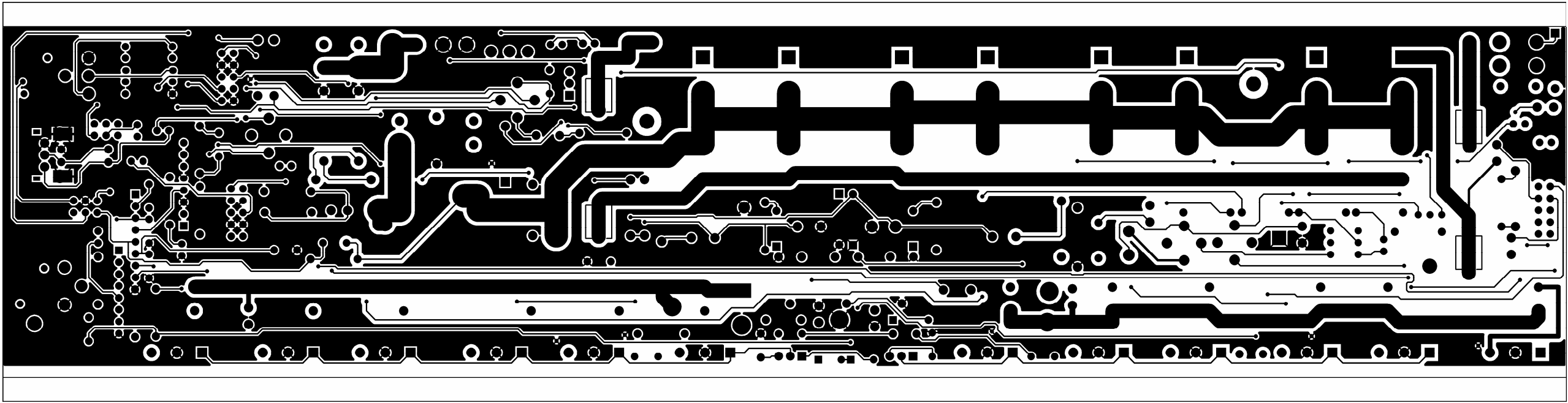

## 6. Test Procedure

### The semi-finished product test procedure

#### 6.1 Test Instruments

1. Power supply
2. Digital voltage meter
3. AP (Audio precision)
4. Oscilloscope
5. Two 8 (400W) resistors

#### 6.2 Test procedures and specification

- a. Set LIMITER and BRIDGE switches at the position of OFF, turn the VRs of CH1 and CH2 to maximum, then turn on the power switch, the power LED will be illuminated (blue), OPERATING/PROTECTION LED is illuminated to be red at first, then become green after 2-5 seconds, the fan will be running. When you use the solder gun to test the position of R1-3 (R2-3), the fan should be accelerated.
- b. Without any signal input, adjust R1-20, R1-21 (R2-20, R2-21) backwards first, make sure the arrow is facing to the rear panel, then adjust forwards, make the arrow is facing to the front panel, then test the DC voltage across the TP1-6 (TP2-6) and the ground, adjusting R1-16 (R2-16), the voltage of R1-16 (R2-16) should be 138mV 2mV.
- c. Connect a load of 4 to each channel, input the signal of 4dBu, then adjust R1-20, R1-21 (R2-20, R2-21), make sure that the crossover distortion reaches its peak.
- d. Turn off the input signal, the standby power consumption should be 75~105W.
- e. Input the signal of 1KHz/3dB to CH1 and CH2, then connect a 4 load to each input channel, CH1 and CH2. Each output should be 69.2V, the distortion should be 1%.
- f. Turn the power switch of the LIMITER to ON position. Set the input to 1KHz/+10dB the clip should be lit up and the signal will not boost.
- g. Use the solder gun to connect R1-50 and R2-50 for about 10 seconds separately. When the outputs of CH1 and CH2 are cut off, OPERATING/PROTECTION LED will be illuminated (red).
- h. Press BRIDGE switch, input the signal of 1KHz/4dB to CH1, connect a 8 load to the bridge output, the output should be more than 133.5V, the distortion should be less than 0.7%.

- i. Adjust volume VR to the minimum, turn LIMITER switch to the position of ON. Set CH1 and CH2 in short circuit, then adjust the VR volume to the maximum, the LED for LIMITER on the panel will be illuminated, the consumption power should be less than 100W.
- j. When the output reaches the MAX, set the output in short circuit, the consumption power should be less than 700W.

### **The finished-product test procedure**

- a. Set LIMITER and BRIDGE switches at the position of OFF, turn the VRs of CH1 and CH2 to maximum, then turn on the power switch on the panel, the power LED will be illuminated (blue), OPERATING/PROTECTION LED is illuminated to be red at first, then become green after 2-5 seconds, the fan will be running. CLICK will be audible from the relay.
- b. Input a 1KHz/3dB signal to CH1 and CH2, then each input channel with 4 of the CH1 and CH2. Each output should be 69.2V, the distortion should be 0.05%.
- c. DISTORTION (SMPTE-IM): Less than 0.05%  
FREQUENCY RESPONSE: 20 to 20 Hz +/-1dB, 10 to 60000Hz +/-3dB  
SNR: 102~108dB below rated output (full band)
- d. Turn the power switch of the LIMITER to the position of ON. When input the signal of 1KHz/+10dB, the clip LED on the panel will be illuminated and the level of output signal won't be increased anymore.
- e. Press BRIDGE switch, input the 1KHz/4dB signal to CH1. Connect a 8 load to bridge output terminal, the output should be more than 128V, the distortion ratio should be less than 0.7%
- f. Adjust the VR volume to minimum, turn the power switch of the LIMITER to ON position. The CH1 and CH2 separated short circuit, then adjust the VR volume to the maximum, the LED for LIMITER should be illuminated. The power consumption should be less than 100W.
- g. When the output reaches the MAX, set the output in short circuit, the consumption power should be less than 700W.

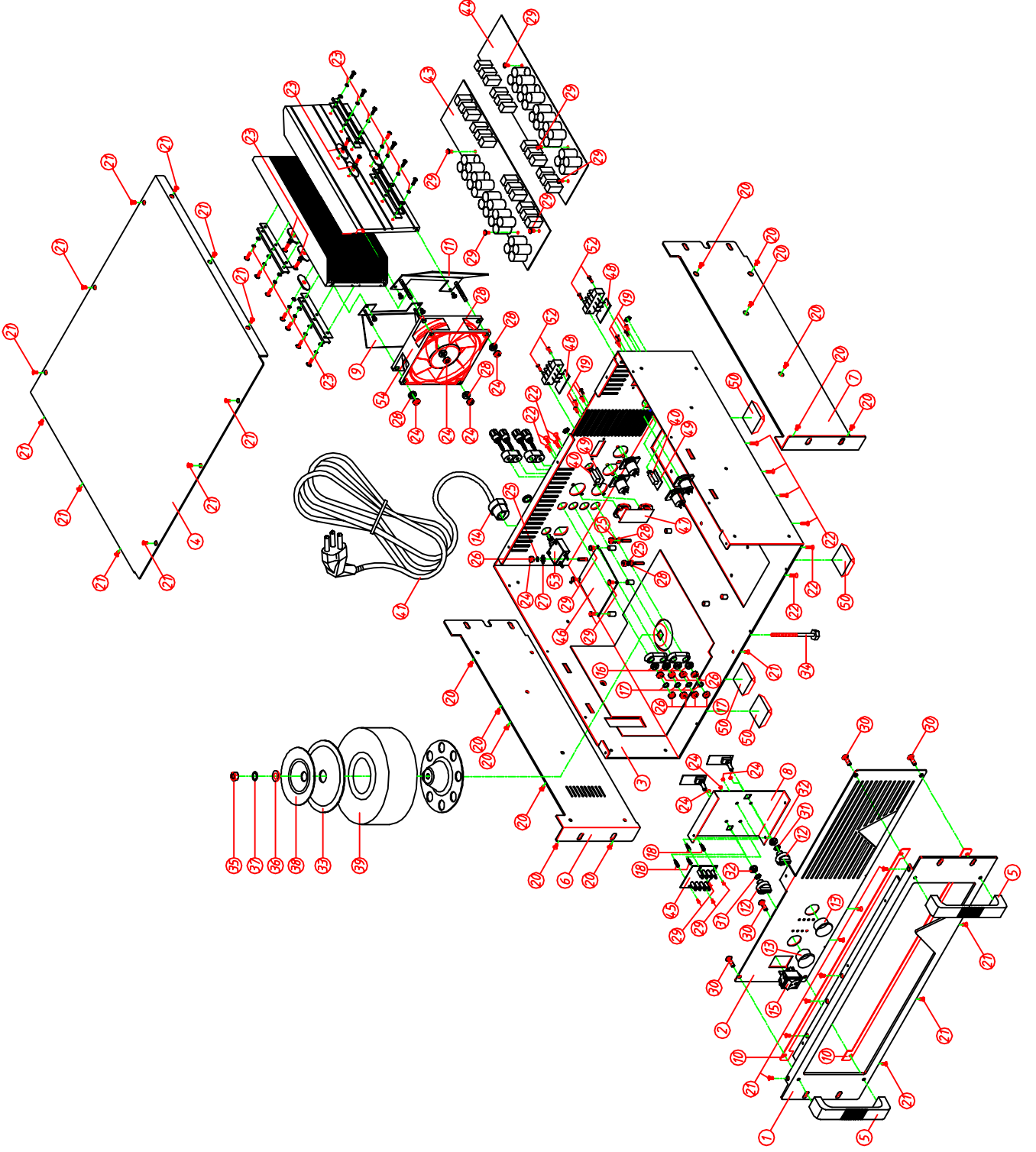

No	Part No.	Description	Specification	Qty.
1	MA04305	ZC-Panel	MISTRAL6000 ALTO-V1.0	1
2	MA00028	ZC-Panel	MISTRAL6000 ALTO-V1.0	1
3	MB03701	ZC-Chassis	MISTRAL6000 V-1.1	1
4	MC00636	ZC-Top cover	MISTRAL6000 V-1.1	1
5	MI02404	ZB-handle	MISTRAL6000 20*25.5*124V1.0	2
6	MI02399	ZB-Fixed bracket	MISTRAL6000 L V1.0	1
7	MI02397	ZB-Fixed bracket	MISTRAL6000 R V1.0	1
8	MI02401	ZB-Front panel	MISTRAL6000 V1.0	1
9	MI02409	ZB-Barrier board	MISTRAL6000 122.5*70.1*66.1	1
10	MI02407	ZB-Iron board	MISTRAL6000 422*14*2.0t V1.0	2
11	MI02411	ZB-Barrier board	MISTRAL6000 422*14*66.1R-V1.0	1
12	NI02650	Plastic knob	18*18mm	2
13	NI02651	Fixed sleeve knob	10* 22.5	2
14	NI02853	Bushing	7P-2 SIZE 11.0 SJT3C#14	1
15	HI00022	Power switch	4P R13-69A	1
16	MF00020	Color washer	5* 12*1t	4
17	MF00039	Washer	5* 8*1t	4
18	MG00247	Copper pillar	M3*10*0.5PH	4
19	MG00061	Screw	M3*10	10
20	MG00295	Screw	M4*6	12
21	MG00025	Screw	M3*6	23
22	MF00042	Screw	M3*10	10
23	MF00037	Washer	3* 5*1t	14
24	ME00015	Color nut	3mm	8
25	MF00038	Washer	4* 7*1t	7
26	ME00016	Color nut	4mm	3
27	MF00048	Locking	4* 8*0.5t	1
28	MF00018	Color washer	4* 10*1t	6
29	MG00041	Screw	M3*6	8
30	MG00075	Screw	M4*16	4
31	ME00006	Nut	9	2
32	MF00004	Color washer	9* 14*0.5t	2
33	MG00437	Rubber coil	20* 120*2tB	1
34	MG00520	Screw	M8*115*1.25PH_V1.0	1
35	ME00026	Zi-nut	M8	1
36	MF00026	Color washer	8* 18*1.5t	1
37	MF00041	Washer	8* 13.5*2t	1
38	MH00766	ZB-iron	11* 90*2_v1.1	1
39	TD00302	Loop transformer	PT-MIS6000_115/230V	1
40	NI00312	SW button	5*5*9 2.8*2.8	2
41	HA03442	Bushing	LT-322+1.5*3C(G05VV-F)2.27M BK	1
42	NC00059	ZD-fixed board	1*46*46 (Sax-2000)	1
43	HK04603	K-PCB	P-MIS60MN CH1	1
44	HK04604	K-PCB	P-MIS60MN CH2	1
45	HK04605	K-PCB	P-MIS60FP2	1

No	Part No.	Description	Specification	Qty.
46	HK04607	K-PCB	P-MIS60PWR	1
47	HK04608	K-PCB	P-MIS60SP	1
48	HK00793	K-PCB	P-MIS2500-INPUT	2
49	HK00787	K-PCB	P-MIS2500-INPUT	2
50	NI01867	Rubber pad	20.5*14*7.6mm(SF-006)	4
51	NI00389	ZD- plastic washer	12* 16*0.5	2
52	MG00027	Screw	M3*12	4
53	HI00142		A0701HM-15A	1
54	HE00083	Fan-1225M12S-PC1	DC12V/0.6A 120*120*25mm 360mm	1

No.	Part No.	Description	Specification	Remark
1	MA04305	panel	MISTRAL6000 ALTO_V1.1	
2	MA00095	panel	MISTRAL600	
3	MA00072	panel	MISTRAL600_V1.1	
4	MI03110	panel	3.1t*133*25.5*1M+5(1M/1.32KG)_V 1.0	
5	MA00028	panel	MISTRAL6000 ALTO_V1.0	
6	MA00099	panel	MISTRAL6000	
7	MA00036	panel	MISTRAL6000_V1.1	
8	MJ00088	single light board	1.5*2135*1220 30.67kg	
9	MB03701	chassis	MISTRAL6000 V_1.1	
10	MB03700	chassis	MISTRAL6000	
11	MB03699	chassis	MISTRAL6000_V1.0	
12	MJ01154	single light board	2.0t*1850*950mm 27.6kg	
13	ME00040	iron pillar	hexagon6.35*M3*10.1	
14	ME00002	screw pillar	M4*20*0.7PH	
15	ME00051	iron pillar	M3*12	
16	MI02405	barrier	MISTRAL6000 75*176.5*195_V1.0	
17	MJ00088	single light board	1.5*2135*1220 30.67kg	
18	MC00636	top cover	MISTRAL6000_V1.1	
19	MC00635	top cover	MISTRAL6000 15*375*433.4_V1.0	
20	MC00634	top cover	MISTRAL6000 15*375*433.4_V1.0	
21	MJ00088	single light board	1.5*2135*1220 30.67kg	
22	MI02404	handle	MISTRAL6000 20*25.5*124_V1.0	
23	MI02403	handle holder	MISTRAL6000 20*25.5*124_V1.0	
24	MI02399	fixed bracket	MISTRAL6000 left_V1.0	
25	MI02398	fixed bracket	MISTRAL6000 left_V1.0	
26	MJ01154	single light board	2.0t*1850*950mm 27.6kg	
27	MI02397	fixed bracket	MISTRAL6000 right_V1.0	
28	MI02396	fixed bracket	MISTRAL6000 right_V1.0	
29	MJ01154	single light board	2.0t*1850*950mm 27.6kg	
30	MI02401	side cover board	MISTRAL6000_V1.0	
31	MJ00069	iron board	1.5*2135*1220 30.67kg	
32	MI02409	barrier	MISTRAL6000 1.2t*50.2*59.3*122.5_V1.1	
33	MI02408	barrier	MISTRAL6000 1.2t*50.2*59.3*122.5_V1.2	
34	ME00194	screw pillar	M3*32*0.5PH_V1.0	
35	MJ00059	single light board	1.2*2135*1220 24.54kg	
36	MI02407	cushion	MISTRAL6000 422*14*2.0t_V1.0	
37	MI02406	cushion	MISTRAL6000 422*14*2.0t_V1.0	
38	MJ01154	single light board	2.0t*1850*950mm 27.6kg	
39	MI02411	barrier	MISTRAL6000 1.2t*50.2*59.3*122.5_V1.1	
40	MI02410	barrier	MISTRAL6000 1.2t*50.2*59.3*122.5_V1.2	
41	ME00194	screw pillar	M3*32*0.5PH_V1.0	



No.	Part No.	Description	Specification	Remark
42	MJ00059	single light board	1.2*2135*1220 24.54kg	
43	NI02650	knob	18*18mm	
44	NI02651	knob fix sheath	10* 22.5	
45	NI02853	bushing	7P-2 SIZE 11.0 SJT3C#14	
46	HI00022	power switch-RS	4p black frame red key	
47	SA00200	bridge rectifier	40A/400V BP40-04	
48	HA01267	wire	380mm UL1015 14AWG orange	
49	HA03431	wire	110mm UL1015 12AWG	
50	HC00295	quick terminal	JS205-110	
51	MF00020	washer	5* 12*1t	
52	MF00039	washer	5* 8*1t	
53	HA02469	wire	3P-3P 480mm 28AWG blue	
54	HA02470	wire	3P-3P 600mm 28AWG blue	
55	HA01394	row-wire connector wiring	3P-3P 120	
56	HA02452	wire	10Pfema*3 415mm UL2651 28AWG PH1.27mm	
57	HA02448	wire	530mm UL1015 14AWG red	
58	HA02449	wire	700mm UL1015 14AWG black	
59	HA01244	2 terminal wiring	380mm UL1015 14AWG red	
60	HA01198	wire	180mm UL1015 14AWG black	
61	MG00247	copper pillar	M3*10*0.5PHsingle length16	
62	MG00061	screw	M3*10	
63	MG00295	screw	M4*6	
64	MG00025	screw	M3*6	
65	MG00042	screw	M3*10	
66	MF00037	washer	3.2* 5.5*1t	
67	ME00015	color nut	3m/m	
68	MF00038	washer	4* 7*1t	
69	ME00016	color nut	4m/m	
70	MF00048	washer	4* 8*0.5t	
71	MF00018	washer	4* 10*1t_V1.0	
72	MF00105	washer	4* 10*1t_V1.0	
73	MJ00058	single light board	1*2135*1220 20.45kg	
74	MG00041	screw	M3*6	
75	MG00075	screw	M4*16	
76	ME00006	nut	9	
77	MF00004	washer	9* 14*0.5t	
78	NI00437	rubber coil	20* 120*2tB	
79	MH00766	iron piece	11* 90*2_V1.1	
80	MH00768	iron piece	11* 90*2_V1.1	
81	MJ01154	single light board	2.0t*1850*950mm 27.6kg	
82	TD00302	transformer	PT-MIS6000_115/230V	

No.	Part No.	Description	Specification	Remark
83	NI00312	power switch button	square 5*5*9 hole 2.8*2.8 black	
84	HA03442	power cord(European 3P)	LT-322+1.5*3C(H05VV-F) 2.27M BK	
85	NI00218	cable tie	ALT-102SB	
86	HJ00006	desiccant	30g	
87	NA00280	PE bag	0.05t*820*650mm	
88	NB02501	gift carton	MISTRAL6000 ALTO	
89	NB03193	cushion	MISTRAL6000_V1.0	
90	NB03245	carton	MISTRAL6000 ALTO_V1.0	
91	NE02227	label	PSA-31500 220-240V	
92	NI00037	adhesive label	0.05*1M	
93	NI00034	membrane	0.045*1M	
94	NF00061	assurance card	ALTO	
95	NE11739	label	MISTRAL6000	
96	NH00012	bond paper	0.04*1M	
97	NI00014	membrane	0.035*1M	
98	NE11347	label	ALTO PI	
99	NH00334	cone paper	0.040*1m	
100	NC00059	fixed board	1*46*46(Sax-2000)	
101	NC00175	insulation board	1.0t*51mm*100M	
102	HK04603	PC board	P-MIS60MN CH1(MISTRAL6000)	
103	HA02759	wire	5P-5P 120mm UL1007 24AWG	
104	MI01954	fixed bracket	MISTRAL4000 1.5t*136*16mm right	
105	MJ00069	iron board	1.5*2135*1220 30.67kg	
106	NC00181	insulator	MISTRAL4000 1.6t*136*16mm	
107	NC00041	insulation board	1.6t*0.65M*70M	
108	ND00182	silicone sleeve	1*30mm	
109	ND00171	silicone sleeve	1*1000mm	
110	ND00521	silicone sleeve	4*90mm	
111	ND00196	silicone sleeve	4*1000mm	
112	ND00520	silicone sleeve	3*90mm	
113	ND00190	silicone sleeve	3*1000mm	
114	MG00171	screw	M3*14	
115	NC00005	silicone insulator	TO-220 square type	
116	NI00279	sleeve	15*20mm	U1-4
117	NI00278	sleeve	15*1000mm	
118	MF00037	washer	3.2* 5.5*1t	
119	MF00030	washer	3.5* 8*0.8t	
120	MJ01200	cushion	MISTRAL4000 14.5*30.5*2t	
121	MJ01201	cushion	MISTRAL4000 14.5*30.5*2t	
122	MJ01154	single light board	2.0t*1850*950mm 27.6kg	
123	MI02676	heat-sink	MISTRAL6000 127.5*40*325 1.87kg_V1.1	

No.	Part No.	Description	Specification	Remark
124	MI03111	heat-sink	127.5*40*1M+5(1M/6.49KG)_V 1.0	
125	HD00029	ceramic tube fuse	15A 6*32mm UL	
126	HC00034	short circuit connector	NO.2700 2.54mm/6mm OPEN	
127	HA01933	jump	2.5mm	J1-4,J1-5
128	HC00076	connector(male)	2P 2.5mm 180°	JP1-14
129	HC00077	connector(male)	3P 2.5mm 180°	R1-5
130	HC00172	connector(male)	3P 3.96mm 180°	JP1-13
131	HC00504	connector(male)	10P 2.54mm 180°	JP1-15,JP1-16,JP1-3
132	HC00111	balance MIC jack	99M-108SP1	J1-2
133	HC00112	balance MIC jack	99M-107SP-1-2 90° PUSH	J1-1
134	HC00056	FUSE holder	8*10.6*1.5 JEF-505	JP1-10,JP1-11,JP1-12,JP1-9
135	HC00324	connect terminal	6.5m/m (PC250)	JP1-1,JP1-2,JP1-5,JP1-6,JP1-7,JP1-8
136	HK02231	Photodiode	P-photosensitive resistance 5LLED	U1-5
137	RH00020	photosensitive resistance	VT90N1	
138	SA00201	L.E.D	5 red(LI3330/A)	
139	NI02779	sleeve	9*30mm	
140	NI00274	sleeve	9*1000mm	
141	HI00039	push-button switch	SP70300-0202-11F1-N	S1-1
142	HI00211	relay	8P 24VDC/16A 881H-1CC-C	K1-1
143	RC00348	semi-fixed resistor	B1K PT1030-V1B102-C1-H10	R1-20,R1-21
144	RC00319	semi-fixed resistor	B100 PT1030-V1B101-C1-H10	R1-16
145	RH00025	thermistor	100 (PAS7101ZF)	R1-50
146	RH00017	thermistor	50 (TDC05A050J)	R1-17
147	RH00021	thermistor	500 (TDC5C150L)	R1-3
148	CN00060	fixed inductance	2uH 10A(CSAF-302824)( 1.5mm*12 1/2T)	L1-1
149	SD00173	integrated circuit	NJM4580L(JRC)	U1-1,U1-2
150	SD00032	integrated circuit	LM317T	U1-4
151	SB00021	power transistor	2SC5200	Q1-10,Q1-11,Q1-12,Q1-13,Q1-9, Q1-14
152	SB00023	power transistor	2SA1943-O	Q1-6,Q1-7,Q1-8,Q1-5,Q1-4,Q1-3
153	SB00129	transistor	MPSA92(TO92)/(PHI)	Q1-15,Q1-16
154	SB00130	transistor	MPSA42(PHILIPS)	Q1-17
155	SB00044	transistor	MJE15033	Q1-2
156	SB00042	transistor	MJE15032	Q1-1
157	SA00026	L.E.D	5 circle red B1115	D1-17
158	SA00188	zener diode	1/2W 7.5V	D1-18
159	SA00117	zener diode	1/2W 5.6V 6B1	D1-7,D1-8
160	SA00197	zener diode	1W 36V 1N4753	D1-21
161	SA00107	zener diode	1W 15V 1N4744	D1-1,D1-4
162	SA00002	high speed diode	1A/600V 1N4937	D1-5,D1-6
163	SA00187	rectifier diode	IN5404	D1-15,D1-16
164	SA00098	rectifier diode	1A/400V IN4004	D1-10,D1-13,D1-14,D1-20,D1-22, D1-23,D1-25,D1-26,D1-28,D1-9
165	SA00093	rectifier diode	1N4148 0.5A	D1-11,D1-12
166	SA00167	bridge rectifier	2A W2-04	D1-19,D1-24,D1-27,D1-2

No.	Part No.	Description	Specification	Remark
167	CB00180	electrolytic capacitor	470uF/160V 18*45mm	C1-15,C1-16,C1-17,C1-18,C1-19, C1-20,C1-21,C1-22,C1-23,C1-24, C1-25,C1-26,C1-27,C1-28,C1-29, C1-30
168	CB00067	electrolytic capacitor	470uF/35V 10*20mm	C1-42
169	CB00057	electrolytic capacitor	220uF/25V 8*11mm	C1-8,C1-45
170	CB00171	electrolytic capacitor	220uF/16V NP 10*12.5mm	C1-34
171	CB00055	electrolytic capacitor	220uF/16V 8*11mm	C1-37
172	CB00149	electrolytic capacitor	47uF/63V 6*11mm	C1-33
173	CB00039	electrolytic capacitor	47uF/25V 5*11mm	C1-5
174	CB00169	electrolytic capacitor	47uF/16V NP 6.3*11mm	C1-9
175	CB00177	electrolytic capacitor	22uF/50V 5*11mm	C1-2,C1-1,R1-43
176	CB00185	electrolytic capacitor	10uF/63V 5*11mm	C1-32,C1-43
177	CF00013	metal-film capacitor MEF	0.068uF/250V	C1-31
178	CF00022	metal-film capacitor MSC	0.022uF/100V 5% CASE01	C1-40
179	CA00053	ceramic capacitor	0.1uF SL	C1-44
180	CA00047	ceramic capacitor	0.033uF	C1-12
181	CA00070	ceramic capacitor	0.022uF/50V±20% Y5U	C1-11
182	CA00043	ceramic capacitor	0.0033uF	C1-13,C1-14
183	CA00024	ceramic capacitor	100PF SL	C1-3,C1-4
184	CA00018	ceramic capacitor	56PF NPO 5mm	C1-36,C1-35,C1-7
185	CA00010	ceramic capacitor	27PF NPO	C1-10
186	RA01016	chassis bracket 5W	2.2K SQM type	R1-23,R1-24
187	RA00870	chassis bracket 5W	12 SQM type	R1-40,R1-41
188	RA00880	chassis bracket 5W	0.22 SQM type	R1-27,R1-28,R1-29,R1-30,R1-31, R1-33,R1-34,R1-36,R1-37,R1-26, R1-35,R1-38
189	RA00063	metal-oxide-film resistor 3W	1.5K RSS P type	R1-63
190	RA01332	metal-oxide-film resistor 3W	15K P type	R1-49
191	RA00051	metal-oxide-film resistor 2W	5.6 P type	R1-39
192	RA00020	metal-oxide-film resistor 1W	6.8K P type	R1-44
193	RA00007	metal-oxide-film resistor 1W	22 P type	R1-25,R1-32
194	RA00027	metal-oxide-film resistor 1W	5.6 P type	R1-22,R1-62
195	RB00010	resistor networks 1/8W	10K 8P C Type	RB1-1
196	RA00713	fixed resistor 1/4W	1.0K F type	C1-6
197	RA00909	fixed resistor 1/2W	82K P type	R1-56
198	RA00908	fixed resistor 1/2W	68K P type	R1-58
199	RA00242	fixed resistor 1/4W	10K M type	R1-54,R1-8
200	RA00184	fixed resistor 1/4W	100 M type	R1-57
201	RA00282	fixed resistor 1/4W	100K M type	R1-43,R1-46,R1-51
202	RA00219	fixed resistor 1/4W	1.8K M type	R1-1
203	RA00246	fixed resistor 1/4W	15K M type	R1-11,R1-64
204	RA00158	fixed resistor 1/4W	0.0 M type	R1-2
205	RA00217	fixed resistor 1/4W	1.5K M type	R1-45
206	RA00616	fixed resistor 1/4W	470 M type	R1-9

No.	Part No.	Description	Specification	Remark
207	RA00200	fixed resistor 1/4W	330 M type	R1-10,R1-55
208	RA00299	fixed resistor 1/4W	330K M type	R1-42,R1-48
209	RA00174	fixed resistor 1/4W	47 M type	R1-52
210	RA00266	fixed resistor 1/4W	47K M type	R1-47
211	RA00239	fixed resistor 1/4W	8.2K M type	R1-53
212	RA00211	fixed resistor 1/4W	820 M type	R1-14,R1-18
213	HB01394	PCB	MIS60MNCH1_VER041020	
214	CA00088	ceramic capacitor	100PF/1000V	
215	HA03434	wire	120mm UL1015 20AWG	
216	HA03435	wire	120mm UL1015 20AWG	
217	HA03436	wire	120mm UL1015 14AWG	
218	HA03437	Wire	120mm UL1015 14AWG	
219	HA03438	wire	120mm UL1015 14AWG	
220	HK04631	PC board	P-MIS60 MN2(CH1) MIS6000	
221	SB00021	power transistor	2SC5200	Q1,Q2
222	SB00023	power transistor	2SA1943-O	Q3,Q4
223	HC00217	terminal for PCB	PC187(0.8)	P1,P2,P3,P4,P5
224	RA00880	chassis bracket 5W	0.22 SQM type	R1,R2,R3,R4,R5
225	HB01397	PCB	MIS60MN2(1*4)_VER041020	
226	RA01496	chassis bracket 10W	5.4K SQM type	R1-15,R1-19
227	HK04604	PC board	P-MIS60MN CH2(MISTRAL6000)	
228	HB01395	PCB	MIS60MNCH2_VER050203	
229	RA00211	fixed resistor 1/4W	820 M type	R2_14,R2_18
230	RA00239	fixed resistor 1/4W	8.2K M type	R2_53
231	RA00266	fixed resistor 1/4W	47K M type	R2_47
232	RA00174	fixed resistor 1/4W	47 M type	R2_52
233	RA00299	fixed resistor 1/4W	330K M type	R2_42,R2_48
234	RA00200	fixed resistor 1/4W	330 M type	R2_10,R2_55
235	RA00616	fixed resistor 1/4W	470 M type	R2_9
236	RA00217	fixed resistor 1/4W	1.5K M type	R2_45
237	RA00158	fixed resistor 1/4W	0.0 M type	R2_2
238	RA00246	fixed resistor 1/4W	15K M type	R2_11
239	RA00219	fixed resistor 1/4W	1.8K M type	R2_1
240	RA00282	fixed resistor 1/4W	100K M type	R2_43,R2_46,R2_51
241	RA00184	fixed resistor 1/4W	100 M type	R2_57
242	RA00242	fixed resistor 1/4W	10K M type	R2_54,R2_8
243	RA00908	fixed resistor 1/2W	68K P type	R2_58
244	RA00909	fixed resistor 1/2W	82K P type	R2_56
245	RB00010	resistor networks 1/8W	10K 8P C Type	RB2_1
246	RA00027	metal-oxide-film resistor 1W	5.6 P type	R2_22,R2_62
247	RA00007	metal-oxide-film resistor 1W	22 P type	R2_25,R2_32

No.	Part No.	Description	Specification	Remark
248	RA00020	metal-oxide-film resistor 1W	6.8K P type	R2_44
249	RA00051	metal-oxide-film resistor 2W	5.6 P type	R2_39
250	RA01332	metal-oxide-film resistor 3W	15K P type	R1_49
251	RA00063	metal-oxide-film resistor 3W	1.5K RSS P type	R1_63
252	RA00880	chassis bracket 5W	0.22 SQM type	R2_27,R2_28,R2_29,R2_30,R2_31, R2_33,R2_34,R2-37,R2_36,R2-26, R2-35,R2-38
253	RA00713	fixed resistor 1/4W	1.0K F type	C2-6
254	RA00870	chassis bracket 5W	12 SQM type	R2_41,R2_40
255	RA01016	chassis bracket 5W	2.2K SQM type	R2_23,R2_24
256	CA00010	ceramic capacitor	27PF NPO	C2_10
257	CA00018	ceramic capacitor	56PF NPO distance 5mm	C2_35,C2_36,C2_7
258	CA00024	ceramic capacitor	100PF SL	C2_3,C2_4
259	CA00043	ceramic capacitor	0.0033uF	C2_13,C2_14
260	CA00070	ceramic capacitor	0.022uF/50V±20% Y5U	C2_11
261	CA00047	ceramic capacitor	0.033uF	C2_12
262	CA00053	ceramic capacitor	0.1uF SL	C2_44
263	CF00022	metal-film capacitor MSC	0.022uF/100V 5% CASE01	C2_40
264	CF00013	metal-film capacitor MEF	0.068uF/250V	C2_31
265	CB00185	electrolytic capacitor	10uF/63V 5*11mm	C2_32,C2_43
266	CB00177	electrolytic capacitor	22uF/50V 5*11mm	C2_1,C2_2,R2-43
267	CB00169	electrolytic capacitor	47uF/16V NP 6.3*11mm	C2_9
268	CB00039	electrolytic capacitor	47uF/25V 5*11mm	C2_5
269	CB00149	electrolytic capacitor	47uF/63V 6*11mm	C2_33
270	CB00055	electrolytic capacitor	220uF/16V 8*11mm	C2_37
271	CB00171	electrolytic capacitor	220uF/16V NP 10*12.5mm	C2_34
272	CB00057	electrolytic capacitor	220uF/25V 8*11mm	C2_8,C2_45
273	CB00067	electrolytic capacitor	470uF/35V 10*20mm	C2_42
274	CB00180	electrolytic capacitor	470uF/160V 18*45mm	C2_15,C2_16,C2_17,C2_18,C2_19, C2_20,C2_21,C2_22,C2_23,C2_24, C2_25,C2_26,C2_27,C2_28,C2_29, C2_30
275	SA00167	bridge rectifier	2A W2-04	D2_2,D2_19,D2_24,D2_27
276	SA00093	rectifier diode	1N4148 0.5A	D2_11,D2_12
277	SA00098	rectifier diode	1A/400V IN4004	D2_10,D2_13,D2_14,D2_20,D2_22, D2_23,D2_25,D2_26,D2_28,D2_9
278	SA00187	rectifier diode	IN5404	D2_15,D2_16
279	SA00002	high speed diode	1A/600V 1N4937	D2_5,D2_6
280	SA00107	zener diode	1W 15V 1N4744	D2_1,D2_4
281	SA00197	zener diode	1W 36V 1N4753	D2_21
282	SA00117	zener diode	1/2W 5.6V 6B1	D2_7,D2_8
283	SA00188	zener diode	1/2W 7.5V	D2_18
284	SA00026	L.E.D	5 circle red B1115	D2_17
285	SB00042	transistor	MJE15032	Q2_1
286	SB00044	transistor	MJE15033	Q2_2
287	SB00130	transistor	MPSA42/(PHILIPS)	Q2_17
288	SB00129	transistor	MPSA92(TO92)/(PHI)	Q2_15,Q2_16

No.	Part No.	Description	Specification	Remark
289	SB00023	power transistor	2SA1943-O	Q2_5,Q2_6,Q2_7,Q2_8,Q2_4,Q2_3
290	SB00021	power transistor	2SC5200	Q2_9,Q2_10,Q2_11,Q2_12,Q2_13, Q2_14
291	SD00032	integrated circuit	LM317T	U2_4
292	SD00173	integrated circuit	NJM4580L(JRC)	U2_1,U2_2
293	CN00060	fixed inductance	2uH 10A(CSAF-302824)( 1.5mm*12 1/2T)	L2_1
294	RH00021	thermistor	500 (TDC5C150L)	R2_3
295	RH00017	thermistor	50 (TDC05A050J)	R2_17
296	RH00025	thermistor	100 (PAS7101ZF)	R2_50
297	RC00319	semi-fixed resistor	B100 PT1030-V1B101-C1-H10	R2_16
298	RC00348	semi-fixed resistor	B1K PT1030-V1B102-C1-H10	R2_20,R2_21
299	HI00211	relay	8P 24VDC/16A 881H-1CC-C	K2_1
300	HI00039	push-button switch	SP70300-0202-11F1-N	S2_1
301	HK02231	Photodiode	P-photosensitive resistance 5LLED	U2_5
302	RH00020	photosensitive resistance	VT90N1	
303	SA00201	L.E.D	5 red(LI3330/A)	
304	NI02779	sleeve	9*30mm	
305	NI00274	sleeve	9*1000mm	
306	HC00324	connect terminal	6.5m/m (PC250)	JP2_1,JP2_2,JP2_5,JP2_6,JP2_7, JP2_8
307	HC00056	FUSE holder	8*10.6*1.5 JEF-505	JP2_9,JP2_10,JP2_11,JP2_12
308	HC00112	balance MIC jack	99M-107SP-1-2 90° PUSH	J2_1
309	HC00111	balance MIC jack	99M-108SP1	J2_2
310	HC00504	connector(male)	10P 2.54mm 180°	JP2_15,JP2_16,JP2_3
311	HC00172	connector(male)	3P 3.96mm 180°	JP2_13
312	HC00077	connector(male)	3P 2.5mm 180°	R2_5
313	HC00076	connector(male)	2P 2.5mm 180°	JP2_14
314	HA01933	jump	2.5mm	J2_4,J2_5
315	HC00034	short circuit connector	NO.2700 2.54mm/6mm OPEN	
316	HD00029	ceramic tube fuse	15A 6*32mm UL	
317	MI02400	side cover board	127.5*40*325 MISTRAL6000 left_V1.2	
318	MI03111	heat-sink	127.5*40*1M+5(1M/6.49KG)_V 1.0	
319	MJ01200	cushion	MISTRAL4000 14.5*30.5*2t	
320	MJ01201	cushion	MISTRAL4000 14.5*30.5*2t	
321	MJ01154	single light board	2.0t*1850*950mm 27.6kg	
322	MF00030	washer	3.5* 8*0.8t	
323	MF00037	washer	3.2* 5.5*1t	
324	NC00005	silicone insulator	TO-220 square type	
325	MG00171	screw	M3*14	
326	ND00520	silicone sleeve	3*90mm	
327	ND00190	silicone sleeve	3*1000mm	
328	ND00521	silicone sleeve	4*90mm	
329	ND00196	silicone sleeve	4*1000mm	
330	ND00182	silicone sleeve	1*30mm	
331	ND00171	silicone sleeve	1*1000mm	

No.	Part No.	Description	Specification	Remark
332	NC00181	insulator	MISTRAL4000 1.6t*136*16mm	
333	NC00041	insulation board	1.6t*0.65M*70M	
334	MI01954	fixed bracket	MISTRAL4000 1.5t*136*16mm right	
335	MJ00069	iron board	1.5*2135*1220 30.67kg	
336	HA02759	wire	5P-5P 120mm UL1007 24AWG	
337	CA00088	ceramic capacitor	100PF/1000V	Q2-1,Q2-2
338	HA03434	wire	120mm UL1015 20AWG	
339	HA03435	wire	120mm UL1015 20AWG	
340	HA03436	wire	120mm UL1015 14AWG	
341	HA03437	wire	120mm UL1015 14AWG	
342	HA03438	wire	120mm UL1015 14AWG	
343	HK04606	PC board	P-MIS60 MN2 MIS6000	
344	SB00021	power transistor	2SC5200	Q3,Q4
345	SB00023	power transistor	2SA1943-O	Q1,Q2
346	HC00217	terminal for PCB	PC187(0.8)	P1,P2,P3,P4,P5
347	RA00880	chassis bracket 5W	0.22 SQM type	R1,R2,R3,R4,R5
348	HB01397	PCB	MIS60MN2(1*4)_VER041020	
349	RA01496	chassis bracket 10W	5.4K SQM type	R2_15,R2_19
350	HK04605	PC board	P-MIS60FP2	
351	HA03444	wire	10P10P 450mm UL2651 28AWG PH1.27mm	JP2-22
352	NI01765	LED spacer support	LEDS-10 10mm	
353	SA00194	L.E.D	3	D1-29,D2-29
354	RC00209	potentiometer	A10K RV110-40E1-225A-A14	VR1-1,VR2-1
355	HC00066	connector(male)	3P 2.5mm 90°	CN1-1,CN2-1
356	SA00054	L.E.D	3m/m round(yellow)long foot 26	D1-30,D2-30
357	SA00053	L.E.D	3 round(red)long foot 26mm	D1-3,D2-3
358	SA00191	L.E.D	3 (LEG2062)	D1-1,D2-1
359	HB00947	PCB	MIS40FP2_VER030710	
360	HA02451	wire	10P-10P 250mm UL2651 28AWG PH1.27mm	JP1-22
361	HK04607	PC board	P-MIS60PWR	
362	HB01398	PCB	MIS60PWR(2*2)_VER050201	
363	CG00044	Metal oxide varisties	NP35L-Y2	R2-67,R2-68
364	RA00954	chassis bracket 10W	2.7K SQM type	R2-73,R2-74
365	HC00324	connect terminal	6.5m/m (PC250)	P1,P2,P3,P4,P5,P6,P7,P8,P9, P10,P11,P12,P15,P16
366	HI00159	relay	4P DC-48V 832A-1A-C	K2-2
367	CB00217	electrolytic capacitor	470uF/50V 10*20mm	C2-46
368	SA00098	rectifier diode	1A/400V IN4004	D2-31
369	HK04608	PC board	P-MIS60SP	
370	HC00442	speaker socket	NL4MP (NEUTRIK)	SPK1,SPK2
371	MJ00942	fixed bracket	CS12/600	
372	MJ00061	iron board	1*2135*1220 20.45kg	
373	HA01239	Wire CF:W209	180mm UL1015 14AWG white	JP5
374	HA01237	Wire CF:W207	200mm UL1015 14AWG gray	JP2



No.	Part No.	Description	Specification	Remark
375	HA02471	wire	360mm UL1015 14AWG white	JP7
376	HA01258	wire	380mm UL1015 14AWG gray	JP8
377	HA03432	wire	100mm UL1015 14AWG	JP1,JP3
378	HA03433	wire	100mm UL1015 14AWG	JP6,JP4
379	HB01396	PCB	MIS60SP(2*4)_VER040922	
380	AC00002	solder wire	63/37%	
381	HK00793	PC board	P-MIS2500-INPUT	
382	HB01105	PCB	MIS40IN-1_VER031206	
383	HC00297	terminal block	DT-55-A14W-03(3PH)	CN1
384	HC00077	connector(male)	3P 2.5mm 180°	CN3
385	HC00079	connector(male)	5P 2.5mm 180°	CN4
386	AC00002	solder wire	63/37%	
387	HK00787	PC board	P-MIS2500-INPUT(MIC jack)	
388	HB01104	PCB	MIS40IN-2_VER031206	
389	HC00077	connector(male)	3P 2.5mm 180°	CN1
390	HC00110	MIC jack	JY-6314-02-340	JP1
391	AC00002	solder wire	63/37%	
392	NA00116	PE bag	0.04t*170*100mm	
393	NI01867	self-adhere foot cushion	20.5*14*7.6mm(SF-006)	
394	NI00389	plastic washer	12* 16*0.5	
395	NI00375	film	45*60.5*0.5mm	
396	MG00027	screw	M3*12	
397	NA00279	clip-chain bag	0.04t*100*150mm_V1.0	
398	AD00012	twin adhesive	90*120mm_V1.0	
399	HA03256	wire	150mm UL1015 14AWG	
400	HI00142	manual reset switch	A0701HM-15A	
401	ND00149	silicone sleeve	12*130mm	
402	ND00026	silicone sleeve	100*20	
403	HE00083	fan-JF0615S2H-000	DC12V/0.6A 120*120*25mm 360mm	
404	NF01939	instruction	MISTRAL6000 ALTO_V1.0	
405	NH00231	paper	889*554mm	
406	ME00202	Zn-nut	M10*8*1.5PH	
407	MF00013	washer	10* 19*2t	
408	MF00044	washer	10* 16*2t	
409	MG00619	Zi-screw	M10*105*1.5PH	